

UNIV. OF
TORONTO
LIBRARY



BINDING LIST NOV 15 1921



Digitized by the Internet Archive
in 2009 with funding from
Ontario Council of University Libraries

Med.
B

THE
British Medical Journal.

THE JOURNAL OF THE BRITISH MEDICAL ASSOCIATION.

EDITED BY

SIR DAWSON WILLIAMS, M.D., D.Sc., D.LITT.,

AND

NORMAN GERALD HORNER, M.A., M.B.

VOLUME I, 1921.

JANUARY TO JUNE.

16849/
10/1/22

London :

PRINTED AND PUBLISHED AT THE OFFICE OF THE BRITISH MEDICAL ASSOCIATION,
429, STRAND, W.C.

LIST OF ILLUSTRATIONS.

SPECIAL PLATES.

	PAOE
Astragalus, Rotation-Dislocation of (Robert Ollerenshaw) facing	155
Coccygeal Fistulae (J. P. Lockhart-Mummery)... facing	806
Encephalitis Lethargica, Histo-pathology of (C. Da Fano) facing	154
"Harlequin Foetus" (J. T. McAuslin) ... facing	155
Hour-glass Stomach (C. Thurstan Holland) ... facing	6, 7
Idiopathic Muscular Dystrophy (H. S. Carter and W. Fleming) ... facing	807
Infective Arthritis and Allied Conditions (W. H. Willcox) facing	806
Osteomyelitis, Acute, of the Long Bones in Children (Alex. Mitchell) ... facing	807

ILLUSTRATIONS IN THE TEXT.

Anaesthetist's Screen	743
Aneurysmorrhaphy, Reconstructive (C. Jennings Marshall) ...	379
Appendix Clamp	568
Asthma and Anaphylaxis (Frank Coke)	372
Auricular Flutter and Fibrillation (Thomas Lewis) ...	551, 591
Catheter Holder for Intrauterine Treatment of Gonorrhoea ...	569
Cleft Palate: New Principle in the Treatment of (H. D. Gillies and W. Kelsey Fry)	336
Disturbed Reflexes in the Production of Symptoms (Sir James Mackenzie)	147
Draining Rack	781
Duval's Lung Forceps, Modification of	273
Eclipse Blindness (William Oliver Lodge)	701
Ether Inhaler, Compact Warm	935
Exomphalos, or Hernia into the Umbilical Cord (Robert Teunent) ...	264
Fractures, Treatment of (S. Alwyn Smith)	483
Gas-oxygen-ether Outfit, Improvements for Use with	19
Gastroptosis, Diagnosis and Treatment of (Major John F. Hall-Edwards)	698
Genito-urinary Surgery, Two Instruments for	568
Giant, Notes on (William Robinson)	560

	PAOE
Gunshot Injury to the Brain (Judson S. Bury)	557
Heart-block (T. Wardrop Griffith)	763
Heart, Dilatation of (D. W. Samways)	189
Intestinal Obstruction after Ventrofixation, Prevention of (Alexander Don)	563
Knee-cap, Improved	164
Manometer for Intrapericardial Pressure, a Portable	465
Massage of Heart and Resuscitation (J. A. Gunn)	11
Metal limbs, Light, in Above-knee Amputations (Edred M. Corner)	524
Microsporion, Unusually Virulent Variety of (Robert Craik) ...	672
Mouth Gag, an Improved	127
Muscle-Tonus, Tonic Rigidity and Tonic Fits (Sir James Purves Stewart)	217
Needles, Surgical	127
Newcastle-upon-Tyne and District, Views of	391, 577, 830
Pelvic Drain, Device to Assist in the Introduction of	197
Physiological Cost of Muscular Work Measured by Exhalation of Carbon Dioxide (A. D. Waller and G. De Decker)... ..	669
Pre-maseteric Fistulae of Stenson's Duct, Operation for the Radical Cure of (Gilbert Chubb)	46
Retinoscope, a Double	307
Reverdin Needle and Holder, Standardized	465
Rhizotomy for the Relief of Pain (Sir William Thorburn) ...	629
Scotometer, Direct Record	645
Stenosis at the Internal Meatus after Suprapubic Prostatectomy (Andrew Fullerton)	301
Temperature Relation to Cardiac Irregularity (R. Macnair Wilson) ...	226
Tuberculin Administration, Tray for	273
Tuberculosis Mortality, 1919	202
Tuberculosis, Pulmonary, Statistics on the Prevention of (Surgeon Commander D. H. C. Given)
Urethral Drainage Bougie	645
<i>Vitex peduncularis</i> in Malarial and Blackwater Fevers (Lieut.-Colonel J. C. S. Vaughan)	187

R
31
B93
1921
v.1
-op 2

INDEX TO VOLUME I FOR 1921.

READERS in search of a particular subject will find it useful to bear in mind that the references are in several cases distributed under two or more separate but nearly synonymous headings—such, for instance, as Brain and Cerebral; Heart and Cardiac; Liver and Hepatic; Renal and Kidney; Cancer and Carcinoma, Epithelioma, Malignant Disease, New Growth, Sarcoma, etc.; Child and Infant; Bronchocele, Goitre, and Thyroid; Diabetes, Glycosuria and Sugar; Light, Roentgen, Radium, X Rays; Status Lymphaticus and Thymus; Eye, Ophthalmia and Vision; Bicycle and Cycle; Motor and Automobile; Association, Institution, and Society, etc. Subjects dealt with under various main headings in the JOURNAL have been set out in alphabetical order under their respective headings—for example, "Correspondence," "Leading Articles," "The Week," "Reviews," etc. Original Articles are indicated by the letter (O).

A.

ABBOTT, William Frederick, obituary notice of, 447
 Abdominal affections, acute, early diagnosis of (W. McAdam Eccles), 663. (O)—Correspondence on, 759
 Abdominal pain, its mechanism and clinical significance (A. E. Maylard), 731. (O)
 Abdominal pain in childhood, diagnostic significance of (Robert Hutchison), 1 (O)
 Abdominal tuberculosis. See Tuberculosis
 Abdominal tumour. See Tumour
 ABEL, H. M.: Albuminuria and life assurance, 84
 Abortion, iostriental (Bernard H. Spilsbury), 461
 ABRAHAM, Phineas Simon, obituary notice of, 406
 Académie de Médecine: Centenary, 26—M. Richelot becomes President, 165—Most suitable time for calling men to the colours, 157
 ACADEMY, ROYAL, OF MEDICINE, IN IRELAND: Section of *Medicine*.—Case of bicornic plague in Dublin, 84
 Section of *Obstetrics*.—"Vicarious menstruation," discussion on, 85—Fibrous and muscular attachments of the vagina, 778—Primary carcinoma of the vagina, 778
 Section of *State Medicine*.—Medical reform in Ireland, 344
 Section of *Surgery*.—Modern surgery of the elbow, 48
 Accessory food factors. See Food and Vitamin
 ACHARD, Professor, elected General Secretary of the Académie de Médecine, 878
 Achondroplasia, hydrocephalus in, 435
 Acid dentifrice, 408, 550
 Acid, diacetic, tests for, 841
 Acid fumes, poisoning from. See Poisoning
 Acidemia (Sir Alnroth Wright), 319
 Acidosis and alkalosis, 508, 542
 ADAM, James: Asthma and anaphylaxis, 478
 ADAMI, J. G.: Pathology of influenza, 48
 ADAMS, John: Congenital syphilis, 460
 ADAMS, J. E.: Exophthalmic goitre, 342—Surgery of the right iliac fossa, 674
 Adams-Stokes syndrome and heart-block, 755, 791
 ADAMSON, H. G.: Relation of skin disease to internal disorder, 303
 ADAMSON, R. O.: Treatment of gastric and duodenal ulcers, 122—Early diagnosis of acute abdominal affections, 759
 ADISON, Right Hon. Christopher: Dinner to, 532—Leading article on, 535—Parliamentary note on, 575—Appreciation of by National Association of Insurance Committees, 661—Cavendish lecture on the part of the State in the prevention of disease, 940
 ADISON, O. L.: Congenital syphilis, 343
 Adenitis, tuberculous (E. C. Lewis), 780
 Adenoid and tonsil operations in outdoor clinics, risks after, 32, 65, 101, 140, 174, 213, 245, 285, 321, 365, 404, 443—Leading article on, 167
 Adenoids, medical treatment of. See above
 Adjustments, fine (leading article), 432
 Admiralty surgeons fees. See Fees and Navy, Royal
 Adrenaline in resuscitation from apparent death (Cranston Walker), 46 (O), 100—A disclaimer, 100—Correspondence on, 100, 136, 482, 544, 582. See also Resuscitation
 "Aesthescopia abdominalis," 435
 Africa, South, and the British Medical Association, 363. See also Association
 Africa, South, reciprocity with, 949—Medical Congress, 959
 After-Care Association. See Association
 AGAR, Wilfred, elected Fellow of Royal Society, 357
 Age and pensions, 249, 370
 Air Force Nursing Service, the Royal, regulations, 625
 Air ambulances, 434
 AITCHISON, R. S.: *A Medical Handbook for the Use of Practitioners and Students*, rev., 164
 ALBEE, Fred. H.: *Orthopaedic and Reconstruction Surgery: Industrial and Civilian*, rev., 85

ALBU, Professor, death of, 878
 Albuminuria, intermittent, in children (F. Moor), 671. (O)
 Albuminuria in relation to life assurance (F. Parkes Weber), 78 (O), 83—Discussion on, 83
 Alcohol in medicine, use of (H. H. Dale), 608—Discussion, 609
 Alcoholism, treatment of, 750—Report of Delrymple House, 750
 Aleppo, small Italian surgical hospital opened at, 562
 Algeria, climate of, 231
 Algiers, guide for motorists in, 683
 Alexander Memorial Prize, 96
 Alimentary disorders, faeces in (Robert Cooper), 528
 Alkaline dentifrice, 692, 726
 Alkaloids and glucosides, 59
 Alkalosis and acidosis. See Acidosis
 ALLAN, James W.: Evolution in relation to disease, 722
 ALBUTT, Sir Clifford: Comparative medicine, 356—Eradication of tuberculosis, 422—Heart-block and the Adams-Stokes syndrome, 755—Pronunciation of vitamin, 828
 ALLEN, F. J.: The beginnings of life, 64
 ALLEN, R. Clayton: Complete heart-block in a case of diphtheria, 267. (O)
 Allen and Hanburys' *Medicamenta Recentia*, 448
 ALLISON, T. M.: Asthma and anaphylaxis, 511
 Amazia (amastia), 369
 Ambulance plans, emergency, 616
 Ambulances, home service, 237—Report, 237, 795—air, 434
 Amenorrhoea following severe trauma (James Hendry), 779
 America. See United States
 American Field Marshal (W. W. Keen), 279
American Journal of Hygiene, 107
American Journal of Obstetrics and Diseases of Children ceases publication, 215
American Journal of Obstetrics and Gynecology: first number, 215
 American Medical Association. See Association
 American University (leading article), 864
 Amoebic dysentery. See Dysentery
 Amputations, above-knee, light metal limba in (Edred M. Corner), 524. (O)
 Anaemia, pernicious: repeated doses of calomel; recovery (John C. Ferrier), 932
 Anaemia, pernicious, splenectomy in (leading article), 470
 Anaemia, splenic: Banti's disease (Sir Berkeley Moynihan), 114. (O)
 Anaesthesia, ethanasa. See Ethanasa
 Anaesthesia and post-operative morbidity (Torrence Thomson), 194
 Anaesthesia, resuscitation in death under. See also Heart massage and Resuscitation
 Anaesthesia, review of books on, 164, 741
 Anaesthetic, a new "ethanasa" (R. L. Mackenzie Wallis and C. Langton Hower), 565
 Anaesthetics in plastic surgery (Mr. Rowbotham and Mr. Magill), 344
 Anaesthetists' screen, 743
 Anaesthetization, examination before (R. W. Apperley), 528
 Anaphylaxis and asthma (Frank Coke), 372. (O)—Correspondence on, 443, 478, 511, 581. See also "Change of air"
 Anaphylaxis and immunity (H. H. Dale), 820
 Anatomical studies (parliamentary note), 654
 Anatomy, human, the teaching and study of (Richard J. A. Berry), 75. (O)—Correspondence on, 143
 Anatomy, review of books on, 17, 272, 387
 ANDERSON, G. C.: The private clinic, 939
 ANDERSON, H. K., elected a member of the Athenaeum Club, 761
 ANDERSON, W. Campbell: Epilepsy considered as a symptom, 444
 Aneurysm of external carotid artery treated by ligature of common carotid artery and internal jugular vein (W. A. Peverley and J. K. Haworth), 339. (O)
 Aneurysms treated by wiring (Sir D'Arcy Power), 427
 Aneurysmorrhaphy, reconstructive, in the third part of the axillary artery (C. Jennings Marshall), 379. (O)
 Angina pectoris, with auricular fibrillation (Hamilton M. Sandison, with a note by Frederick W. Price), 339. (O)

Angina pectoris, review of book on, 125
 Angio pectoris, surgical treatment of (leading article), 823
 Angio-neurotic oedema, 180, 480, 545
 Angio-neurotic oedema treated by horse serum, 68, 102
 Aniline factory workers, tumour of bladder among, 645. See also Tumour
 Animal disease communicable to man (Professor Hobday), 351. See also Mange
 Ankylostomiasis campaign in Egypt (A. F. MacCallan), 674
 ANNIS, E. G.: called to the Bar, 918
 ANSPACH, Brooke M.: *Gynaecology*, rev., 898
 Anthracite stove for cooking and heating water, 959
 Anthrax, cutaneous, treatment of (W. H. Ogilvie and A. W. Hall), 889. (O)
 Anthrax from shaving brushes, 207, 579, 889
 Antigonococcal serum, the use of (Frances Ivens), 77. (O)
 Antimalaria. See Malaria
 Antimony tartrate in bilharziasis (F. O. Lasbrey and R. B. Coleman), 299. (O)
 Antimony in leprosy (F. G. Cawston), 419. (O)
 Antimony treatment for ex-service men suffering from bilharziasis (parliamentary note), 476
 Antimony for venereal granuloma (W. E. Giblin), 932
 Antimony. See also Tartar emetic
 Antisepsis and aepsis, review of book on, 386
 Antitetanic serum, large doses of, successful in a case of severe tetanus, 121
 Antlers, review of book on, 195—Correspondence on, 247
 Antlers, stag's, and evolution, 247
 Aortic blood pressure. See Blood
 Aortic incompetence, blood pressure readings in (O. K. Williamson), 734. (O)
 Aphasia, a new study of (leading article), 863, 946—Correspondence on, 913
 Aphasia, sensory, review of book on, 706
 Apothecaries Society of London: Pass lists and degrees, 106, 407, 840
 Apothecary poet (Keats), 360, 905
 Appeal tribunals. See Pensions
 Appendicitis, dental caries and gastric ulcer, 960
 Appendicitis simulated by mesenteric lymphadenitis (J. W. Struthers), 706
 Appendix clamp, 568
 Appendix communicating with colon, 146
 Appendix, "double," 762
 APPERLEY, R. W.: Examination before anaesthetization, 528
 Approved societies and hospitals (parliamentary note), 576
 ARCHER-HALL, H. W.: Eclipse blindness, 837
Archivos de Medicina Cirugia y Especialidades, 347
 Argentina: Tuberculosis mortality in Rio de Janeiro, 739
 ARMOUR, Donald: Exophthalmic goitre, 342
 Arms, position of in breech with extended tube, 320. See also Labour
 ARMSTRONG, Captain Edward Randolph, obituary notice of, 445, 481
 ARMSTRONG, Richard R.: Serological characters of disease-producing pneumococci, 259. (O)
 ARMSTRONG-JONES, Sir Robert: Use of alcohol in medicine, 609
 ARMY, BRITISH:
 Additional pay for officers on committees, 515
 Army Dental Corps formed, 133
 Black Sea army, 144
 Defence force, medical students in, 716
 Hygiene in, 106
 Parliamentary notes, 716
 R.A.M.C. Officers in India: new rates of pay for, 406—Roll of Honour, 406—War Memorial, 536
 R.A.M.C. Fund. See Fund
 Titles of retired officers, 690
 Army Dental Corps formed, 133. See also Army, British
 Army, Indian. See Indian Medical Service

- Army Orders: *Re hygiene in the army*, 105—*Re formation of the Army Dental Corps*, 133—*Additional pay for officers on committees*, 515
- Arrest of medical men in Ireland, 319
- Arris and Gale Lecture. *See* Lecture
- Arsenic, prolonged administration of, 482
- Arsenical poisoning, delayed, case of (George St. George), 192
- Arsenobenzol treatment of venereal diseases (parliamentary note), 753
- Artery, axillary, reconstructive aneurysmorrhaphy in the third part of (C. Jennings Marshall), 379 (O)
- Artery, external carotid, aneurysm of, treated by ligation of common carotid artery and internal jugular vein (W. A. Peverley and J. K. Haworth), 339. (O)
- Artery, left subclavian, ligations of, 573, 739
- Arthritis, acute infective (F. J. Steward), 727. (O)
- Arthritis, infective, and allied conditions (W. H. Willcox), 804. (O)
- ARTHUS, Maurice: *De l'Anaphylaxie à l'Immunité*, rev., 818
- Artificial eyes. *See* Eyes
- Artificial limbs: Correspondence on, 69, 103—*Demonstration by Gustave Monod of films for the study of movement*, 287—*Pamphlet for guidance of disabled men with*, 307—*Dr. Bidou's improvements on*, 436—*Parliamentary note*, 476, 654—*Light metal limbs in above-knee amputations* (Edred M. Corner), 524. (O)
- Artificial pneumothorax (Clive Riviere), 810. (O)—*Discussion*, 814
- Artificial respiration. *See* Respiration
- Asepsoids, " nasal, 232
- Asia, Central, scientific expedition to, 350
- "Aspirin habit", 691
- Assistant surgeons, civil, 755
- Association, American Hospital, 919
- Association, American Medical: Annual meeting, 788
- Association, American Orthopaedic: Annual meeting, 839
- Association, British: *The Advancement of Science*, 1920, rev., 164—*Presidents of Sections*, 473
- Association of British Chemical Manufacturers—*The fine chemical industry*, 133, 315
- Association, British Hospitals: Scottish Regional Hospitals Committee, 208
- Association, British Medical: Annual Meeting (1921) at Newcastle-upon-Tyne, 93, 391, 535, 577, 679, 828, 830—*Pathological Museum*, 93, 957—*University of Durham College of Medicine*, 391—*Armstrong College*, 391—*Royal Victoria Infirmary*, 392—*Literary and Philosophical Society*, 392—*Hancock Museum*, 393—*Leung Art Gallery*, 393—*Programme*, 393, 535, 679, 789—*Local antiquities*, 836—*Places of interest in the neighbourhood*, 832
- Association, British Medical: An annual stock-taking (leading article), 824
- ASSOCIATION, BRITISH MEDICAL: *Border Counties Branch*.—*Treatment of fractures*, 229
Camberwell Division.—*General meeting*, 161—*One or two points of medical utility*, 161—*Albuminuria in impetigo in children*, 161—*Good effect of simple puncture in delayed resolution in pneumonia*, 161
Dundee Branch.—*War lessons in civil life* (Sir Henry Gray), 62
Edinburgh Branch.—*Winter clinical meeting*, 439
Exec. South Division.—*Some points in the surgery of the right iliac fossa*, 674
Leeds Division.—*Graphic methods in cardiac diagnosis*, 813—*Leucocytic changes in Hodgkin's disease*, 813—*Post-operative x-rays in breast cancer*, 814
Midland Branch.—*Joint meeting with Nottingham Medico-Chirurgical Society*, 229—*Fractures of the femur*, 229
North of England Branch.—*Presentation to James Dou*, 234
Sheffield Division.—*Joint meeting with Sheffield Medico-Chirurgical Society*, 541—*Note on the Commission to the Far East for inquiries re control of venereal disease*, 541
- Association, British Medical: A constitutional problem (leading article), 647
- Association, British Medical, the machinery of (leading article), 746
- Association, British Medical, and South Africa, 363
- Association of Certifying Factory Surgeons: Annual meeting and dinner, 55—*Chief inspector's attention drawn to two matters of importance*, 430
- Association pour le Développement des Relations Médicales (A. D. R. M.), 325
- Association, Hispano-Portuguese, for the Advancement of Science, 350
- Association, Irish Medical: Annual meeting, 953
- Association, Irish Medical Schools' and Graduates: Annual meeting 499
- Association, London, of the Medical Women's Federation: Psychological forgetting in relation to lying, 123—*Influence of diet on the teeth*, 385—*The circulation during and after acute infection*, 462—*Tuberculosis in children of school age*, 641—*Tuberculous adenitis: its diagnosis and treatment*, 780
- Association, Medical Officers of Schools: Annual meeting and election of president, 35
- Association, Mental After-care: Annual meeting, 353
- Association of Port Sanitary Authorities, rats, ships, and crews' quarters, 866
- Association for Prevention of Tuberculosis, National: Annual conference, 126. *See also* Tuberculosis prevention
- Association of Public Vaccinators: Annual meeting 317—*Annual dinner*, 317
- Association of School Medical Officers: School punishments, 312
- Association of School Medical Officers of Scotland: Conference, 282, 580
- Association of Surgeons of Great Britain and Ireland: Annual meeting, 718
- Asthma, bronchoscopy for (Mr. Syme), 855
- Asthma, use of peptone in (A. G. Auld), 696. (O)
- Asthma and anaphylaxis (Frank Coke), 372. (O)—*Correspondence on*, 443, 478, 511, 581. *See also* "Change of air"
- Asthma clinic in New York Hospital, 615
- Astigmatism, the axis of (N. Bishop Harman), 666 (O)
- Astragalus, rotation dislocation of (Robert Ollerenshaw), 155. (O)
- Asylum, Dundrum, staff (parliamentary note), 716
- Asylum, Glasgow Royal: Annual meeting, 318
- Asylums, ex-service men in (parliamentary note), 61, 505, 716, 952
- Asylums, Glamorganshire County (parliamentary note), 438
- ATKINSON, F. P.: Chronic retention of urine arising from prostatic disorder, 692
- Atoxyl in sleeping sickness 774
- Attributability, medical decisions on. *See* Pensions
- AULD, A. G.: Use of peptone in asthma and its congeners, 696. (O)
- Auricular fibrillation, value of digitalis in (J. D. Harris), 49
- Auricular fibrillation, mitral stenosis and the action of digitalis (C. H. Cattle), 521. (O)
- Auricular fibrillation, paroxysmal, pain in (E. E. Laslett), 703
- Auricular flutter and fibrillation, nature of (Thomas Lewis), 551, 590 (O)—*Leading article on*, 612
- Australia: Influenza epidemic in Western Australia, 613—*Medical legislation*, 439—*Nurses' Registration Act*, 439—*Opticians Act*, 439—*Sydney University professorship of anatomy* 63. *See also* New South Wales
- Austria: Insurance society founded at Vienna under the name of the "Yellow Cross," 389—*Tuberculosis mortality in*, 468—*British home for necessitous Austrian children at Klessheim*, 569
- Automobile dispensaries for child welfare work in U.S.A., 944
- Auxiliary Division in Ireland, medical needs of (parliamentary note), 654
- Aviation diseases, review of books on, 18; English editions of, 63
- AYLWARD, R. D.: Glandular fever, 509
- B.
- BABONNEIX, L. (and others): *Traité de Pathologie Médicale et de Thérapeutique appliquée*, rev., 306, 897
- BABBIE, Sir William, estate of, 482
- Baby shows, hints for judges, 959
- Baby Week Council, National: Message from the Queen, 879—*Infant mortality*, 879—*Coal and health of children*, 879—*Healthy infants*, 879—*Endowment of motherhood*, 879—*Conference*, 959
- Bacilli destroyed by electricity (P. C. Collingwood Fenwick), 812
- BACK, Ivor (and Tudor EDWARDS): *Surgery*, rev., 429
- BACON, A.: On the probable identity of *Rickettsia pediculi* with *Rickettsia quintana*, 156. (O)
- Bacteriology, review of book on, 857
- BADCOCK, J. H.: The Dentists Bill, 511
- BAIRD, Captain H. H. C.: Artificial limbs, 69—*Pamphlet for guidance of disabled ex-service men*, 307
- BAKER, T. Thorne: *Radiographic Technique*, rev., 675
- BALDWIN, Aslett: Pruritus ani, 603
- BALFOUR, Andrew: *War Against Tropical Disease*, rev., 196—*Future of research in tropical medicine*, 834
- BALL, Sir Arthur (and H. DRYBY): Case of plague in Dublin, 84—*Appreciation of Arthur Francis Dobbs*, 660
- BALLANTYNE, J. W.: The maternity hospital with its ante-natal and neo-natal departments, 221. (O)—*"Twilight sleep"*, 341
- BALLERINI, Giorgio, death of, 828
- BALME, Dr.: Surgical practice in China, 270, 308
- Balneotherapy and advancing years (G. L. Pardington), 193
- BANDLER, Samuel Willie: *The Endocrines*, rev., 816
- BANERJEE, MOHENDRA NATH, C.I.E. conferred upon, 865
- BANGAY, Surgeon-Lieut. James Dorrington, O.B.E. conferred upon, 34
- BANKART, A. S. Blundell: Postural or so-called static deformities, 587, 636. (O)
- Banti's disease, 114. *See also* Splenic anaemia
- BAR, calls to the, 661, 918
- BARBER, Hugh: Note on complete heart-block in a case of diphtheria, 267
- BARBER, H. W.: Relation of skin disease to mental disorder, 303
- BARCLAY, A. E.: Plaster models of X-ray observations of the stomach, 225—*Diathermy for inoperable growths*, 462
- BARDSWELL, Noel: *Handbook for Tuberculosis Workers*, rev., 126
- BARENTE, Frank H.: Antiquity of syphilis, 704
- BARKER, Surgeon-Lieut.-Col. James, obituary notice of, 690
- BARKER, Lewellys: Diabetes insipidus and the pituitary, 238
- BARKER, W. N.: Cell activity and specific drug action, 877
- BARLOW, Sir Thomas: Appreciation of Peter Duncan, 624
- BARNES, Henry, death of, 574; obituary notice of, 624
- BARNETT, George S.: Congenital deficiency of the diaphragm, 602
- BARR, Archibald: The optophone, 574
- BARR, Sir James: Preparation of scientific papers, 720, 873—*Appointed Deputy Lieutenant for Lancashire*, 833
- BARTHOLOMEW, Urquhart: Spasmodic hiccough, 82
- BARTON, H. T. presentation to, 210
- BASKETT, B. G. M.: Risks after operations on tonsils and adenoids in outdoor clinics, 213—*The fall in the tuberculosis death rate*, 443
- BASSETT-SMITH, Surgeon on Rear Admiral P. W., K.C.B. conferred upon, 865
- BASTIAN, Surgeon-Commander W.: The beginnings of life, 64
- Beth and Co., catalogue, 108
- BATTAMS, J. Scott: Psychic phenomena, 880
- BATTEY, Robert, monument to, 931
- BAUMEL, J. (and G. LARDENNOIS): *Les infections gangréneuses des membres consécutives aux plaies de guerre*, rev., 708
- BAXTER, E. M. (and A. J. EAGLETON): Virulence of diphtheria-like organisms, 775. (O)
- BAYLISS, W. M.: Sir James Mackenzie's theory of disturbed reflexes, 243—*Principles of General Physiology*, rev., 675
- BAYLY, H. Wensey: Venereal disease prophylaxis, 32, 140, 247, 758—*Value of the Wassermann reaction*, 686—*North European conference on venereal diseases*, 957
- BAZY, Pierre, elected a member of the Académie des Sciences, 267
- BEADNELL, Surgeon Captain C. Marsh: The beginnings of life, 142—*Evolution and disease*, 622
- BEATTIE, N.: Prevention of puerperal infection, 874
- BEAUMONT, W. M.: Ocular disease in the gouty, 271
- BECLERE, COTTENOT, and LABORDE: *Radiologie et Radiumthérapie*, rev., 676
- BEDDOE, David Morgan, obituary notice of, 513
- BEGG, Charles: Irritable bladder, 511
- Beginnings of life. *See* Life
- Belgian Army Medical Corps, memorial to in Brussels, 879
- Belgian qualifications and the Medical Register, revocation of order re, 60
- BELL, Julia (and Karl PEARSON): *A Study of the Long Bones of the Human Skeleton*, rev., 324
- BELL, Mary: Psychological forgetting in relation to lying, 123
- BELL, W. Blair: *The Sex-Complex*, rev., 86—*Indications for blood transfusion*, 564—*Prevention and treatment of puerperal infections*, 693. (O)—*Appointed to the chair of obstetrics at Liverpool University*, 911
- Bellahouston Hospital. *See* Hospital
- Bengal, medical colleges in, 97
- BENNETT, Norman Godfrey, appointed examiner for Royal Naval Dental Service, 879
- BENNETT, T. F.: Chemical estimation of gastric function, 583
- BENSON, Annette Matilda: Kaiser-i-Hind medal awarded to, 61
- Bequests to hospitals and medical charities, 250, 683, 919
- BERANECK, Edmund, death of, 447
- BERESFORD, G. W.: Ununited fractures, 456. (O)
- BERNHARD-SMITH, A.: Angio-neurotic oedema, 180
- BERRY, James: Exophthalmic goitre, 268
- BERRY, Martin: Exophthalmic goitre, 425
- BERRY, Richard J. A.: The teaching and study of human anatomy, 75. (O)
- BEZANCON, F.: *Précis de Microbiologie Clinique*, rev., 643
- Bibliographical references, 479
- Bibliographie des Livres Français de Médecine et de Sciences, 532
- BICKERSTETH, Robert A., dinner to, 656
- BIDOU, G.: *Des action musculaires artificielles*, rev., 18—*Artificial limbs*, 436
- BIGGAM, Captain Alexander G., O.B.E. conferred upon, 917
- BIGGER, Edward Coey, knighthood conferred upon, 58, 61, 62

- Biogs, J. J. E.: Truss fitting, 516
 Bilharzias, control of, destruction of molluscs, 479
 Bilharzias disease, note on the story of, 501
 Bilharzias disease in Egypt (J. B. Christopher-son), 491. (O)
 Bilharzias treated by antimony tartrate (F. O. Lasbrey and R. B. Coleman), 299. (O)
 Bilharziasis, emetine in, 70, 586
 Bilharziasis treatment ("stibenyli"). 650—Parliamentary note, 753
 Biliary calculi, recurrence of (leading article), 534
 Biliary tract, medical drainage of, 58
 Binet-Simon scale of mental testing, 817
 Binks, H. B.: Summer prurigo, 796
 Birdwood, G. T.: *Practical Bazaar Medicines*, rev., 197—*Clinical Methods for Students in Tropical Medicine*, rev., 898
 Birmingham: Territorial dinner, 252
 Birthday honours. *See* Honours
 Birth-rate Commission on Venereal Disease, 314
 Births, marriages, and deaths, 472
 Bishop Auckland, county maternity home at, 833
 Bishop, H. D.: Bovine tuberculosis, 544
 Black, Major K.: An improved mouth **886**, 127
 Black Sea army. *See* Army, British
 Blackhall-Morison, Alexander: Resuscitation of the apparently dead and the relation of cardiac innervation to it, 136—The retarded cinema and cardiac action, 402
 Blackwater fever. *See* Fever
 Bladder: Ectopia vesicae. *See* Ectopia
 Bladder, irritable, 480, 511, 544, 582, 659
 Bladder, suprapubic drainage of, the De Pezzer tube (G. S. Motherell and Clifford Morson), 418. (O)
 Bladder, tumour of. *See* Tumour
 Blake, F. G.: Experimental influenza infection, 94—Transmission of measles to monkeys, 500, 904
 Blakesley, Major Henry J.: The male venereal clinic at the Royal Infirmary, Leicester, 619
 Blayne, Christopher: *The Purple Sapphire and other Posthumous Papers*, rev., 676
 Blease, Arthur T.: Refraction, work among school children, 792
 Blind children, Braille type for, 179
 Blind, gardening for the, 680—Guild of blind gardeners, 692
 Blind, National Institute for: Medical articles in Braille, 35
 Blind Persons Act (parliamentary note), 505
 Blind welfare of: Advisory committee (parliamentary note), 475—Advisory committee for Scotland, 657—Reconstitution of advisory committee, 691—Scottish Board of Health's circular, 953
 Blindness, eclipse (William Oliver Lodge), 701. (O)—Correspondence on, 756, 837
 Bloch, C. E.: Diseases of infants due to prolonged feeding with excess of carbohydrates, 235. (O)
 Bloedorn, W. A.: Acute benign lymphoblastosis, 649
 Blood cells, red, diurnal changes in the size of, 239
 Blood changes in T. N. T. poisoning, 179
 Blood group in infants and mothers (Francis B. Chavasse), 641
 Blood, new growth and a reducing substance in (A. S. Leyton and H. G. Leyton), 852. (O)
 Blood pathology, review of books on, 780
 Blood pressure readings in aortic incompetence (O. K. Williamson), 734. (O)
 Blood pressures, pulmonary and aortic, 688, 719. *See also* Cardiac peristalsis and Heart
 Blood transfusion, indications for (W. Blair Bell), 564
 Blood transfusion in treatment of melaena neonatorum (R. Douglas Laurie), 521—Correspondence on, 791
 Board, Central Midwives, 97, 317, 540, 718, 919—Annual report, 97
 Board, Central Midwives (Ireland), 362
 Board, Central Midwives (Scotland), 209
 Board of Education: Change of address of Medical Branch, 69—Estimates, 575—And the effect of the Daylight Saving Act on young children, 840
 Board, Metropolitan Asylums: Report on infectious fever cases in the autumn of 1920, 361
 Body, dead, property in a, 216
 Body, transfusion of, 550, 581
 Boils. *See* Leishmaniasis, local
 Bolas, B. D.: *Handbook of Laboratory Glass-blowing*, rev., 743
 Bolz, L.: Influence of the ductless glands in evolution, 821
 Bombay, dental school in, 136
 Bone, review of books on, 565
 Bones and joints, surgery of (S. T. Irwin), 497
 Bones, the long, review of books on, 124
 Bones, some of the rarer conditions of (Thurstan Holland), 270
 Bonney, Victor: Position of the arms in breech with extended legs, 320—A standardized Reverdin needle and holder, 465
 Boothby, Walter M. (and Irene Sandford): *Laboratory Manual of the Technique of Bursal Metabolic Rate Determination*, rev., 567
 Bordeaux: Rockefeller tuberculosis dispensary to be built in memory of American nurses, 919—Nursing associations of America to erect a memorial to American nurses who gave their lives in the war, 937
 Borde, E. (and H. Vaguez): *Le Coeur et l'Aorte: Etudes de Radiologie clinique*, rev., 499
 Bottles, graduated, 146
 Bourne, Aleck W.: Puerperal salpingo-peritonitis, 495
 Bourne, Geoffrey: Case of complete pneumothorax in an infant, due to pulmonary tuberculosis, 526. (O)
 Bourquelot, Em.: Alkaloids and glucosides, 59
 Bousfield, Edward Collins, obituary notice of, 177
 Bousfield, Paul: *The Elements of Practical Psycho-Analysis*, rev., 531
 Bovine tuberculosis, 544. *See also* Tuberculosis
 Bowel. *See* Intestine
 Bowel cancer. *See* Cancer
 Bowen, Wilbur Pardon: *Applied Anatomy and Kinesiology: The Mechanism of Muscular Movement*, rev., 17
 Bowley, Sir Anthony, portrait of, 407—Non-operative treatment of surgical tuberculosis, 424
 Bowser, J. Edward: Napoleon and Murat, 722
 Boyd, William: *Physiology and Pathology of the Cerebro-spinal Fluid*, rev., 270—Epidemic hiccough and encephalitis lethargica, 572
 Boyle, H. Edmund G.: Improvements for use with gas-oxygen-ether outfit, 19
 Brackenbury, H. B.: Ministry of Health and the profession, 31, 99
 Bradford, course for the D.P.H. at, 388
 Bradford Municipal General Hospital, 171—Parliamentary note, 540. *See also* Hospitals, voluntary
 Bradford practitioners meet to consider the Local Medical Advisory Committee's report as to St. Luke's Hospital, becoming a municipal general hospital, 287
 Bradford scheme and voluntary hospitals. *See* Hospitals, voluntary
 Bradley, E. J.: Case of myoclonic epidemic encephalitis, 891
 Bradshaw Lecture. *See* Lecture
 Bradycardia (H. C. Woodhouse and F. Carlton Jones), 528
 Bragg, Sir William: *The World of Sound*, rev., 499
 Braille type for blind children, 179
 Brain, gunshot injury to, involving both cortical and subcortical tissue (Judson S. Bury), 556. (O)
 Brain, review of books on, 345
 Brain Workers' Association congress, 927
 Bram, Israel: *Erophthalmic Gaitre and its Non-surgical Treatment*, rev., 305
 Bramwell, Edwin (and H. P. Dykes): Cervical ribs and pressure symptoms, 384
 Branson, W. P. S.: Etiology of rickets, 685
 "Brass fever." *See* Fever
 Bracer, Professor, and clinical research in pharmacology, 868
 Brazil: New medical faculty established in, 609—Tuberculosis mortality in, 739
 Breast cancer. *See* Cancer
 Breast epithelium, pathology of (Sir G. Lenthal Chestle), 895
 Breech presentation. *See* Labour
 Brend, William A.: Psychotherapy, 168
 Breton, Lieut.-Col. Frederick S., Order of the Crown of Italy conferred upon, 515
 Brewer, Dunstan: Glandular fever, 582
Bridge, Royal Auction, rev., 465
Bridge-les-Bain, water, of, 661
 Briggs, Henry: The position of the arms in breech with extended legs, 366—Operative treatment of genital prolapse, 894
 Bright, Richard, his less known contributions to medicine, 906
 Bright's disease, the discoverer of, 573
 Bristol: Medical school, 63—Small-pox at, 473—Post-graduate study, 621
 Bristow, W. Rowley: Habitual dislocations, 384
 British aid for men of letters and science in Russia, 65, 250. *See also* Russia
 British Guiana, filariasis expedition to, 280
 British Hospitals Association. *See* Association
 British Industries Fair, 326
British Journal Photographic Almanac, rev., 499
 British Medical Association. *See* Association
 British Pharmaceutical Conference: The future of pharmacy, 918
 Brockbank, E. M. (and Albert Ramsbottom): *The Clinical Examination of Diseases of the Lungs*, rev., 707
 Brodribb, C.: Prevention of puerperal infection, 874
 Brogden, Richard William, obituary notice of, 760
 Bromley, whole time medical officer for (parliamentary note), 438
 Brook, Elizabeth, Serbian Order of St. Sava conferred upon, 446
 Bronchoscopy in treatment of asthma (Mr. Sime), 855
 Browdy, M. W.: Syringe for treatment of the posterior urethra, 708—Prevention of urethral stricture, 762
 Brown Animal Sanatory Institution, report, 918
 Brown, G. E.: Medical drainage of the biliary tract, 58
 Brown, Herbert H.: Ectopia vesicae successfully treated by transplantation of the trigone into the sigmoid, 15
 Brown, John: Name for accessory food factors, 107
 Brown, Lieut.-Col. Robert Tilbury, Belgian Order of Leopold conferred upon, 253
 Brown, William: *Psychology and Psychotherapy*, rev., 530
 Brown, W. Langdon: Glycosuria, 345
 Browne, F. J. and R. W. Johnson: Double congenital hydronephrosis, 160—Twilight sleep, 342
 Browne, John Walton, knighthood conferred upon, 959
 Bruce, William Ironside, obituary notice of, 481, 514—Message from the King, 514
 Brussels: Société Braxelloise de laryngologie formed in, 51—Rockefeller Foundation endows a training college for nurses in, in memory of Edith Cavell and Madame DePeppe, 725
 Bryce, Alexander: *Intestinal Toxaemia or Auto-intoxication in the Causation of Disease*, rev., 780
 Buchanan, Lieut.-Col. A.: Teaching of the mechanism of labour, 238
 Buchanan, G. S.: Internal organization and public health, 331 (O)—Ministry of Health memorandum on encephalitis lethargica, 508—Hygiene of seamen, 538
 Buchanan, R. J. M.: Pathology of influenza, 426
 Bucharest names a street after the French physician, J. Cluget, 215
 Buckell, Ernest Hook, obituary notice of, 445
 Budget, the, 652, 655
 "Buff Book," 842, 880, 920. *See also* Supplement Index
 Buis, H. Massac: Motor notes for medical men, 22, 389
 Buis, R. C.: Voluntary Hospitals Committee, 956
 Bullet in the cauda equina (D. H. Vickery), 302
 Bulloch, W.: Use and abuse of scientific medical literature, 939
 Bullock, Joseph Ernest, obituary notice of, 445
 Bullock, W. A.: Defects in tuberculosis administration, 913
 Bunting, C. H.: Fate of the lymphocytes, 905
 Burgess, Arthur H., appointed deputy-lieutenant for Lancashire, 833
 Burke, Major John FitzGerald, obituary notice of, 626
 Burnett, R. W.: Treatment of pneumonia, 586
 Burman, Frederick J., obituary notice of, 660
 Burnett, Sir Napier: Appointed a Knight of Grace of the Order of St. John of Jerusalem, 215—Appointed chief executive officer of the Joint Council of British Red Cross and Order of St. John, 287
 Burnett, S. H.: *The Clinical Pathology of the Blood in Domesticated Animals*, rev., 780
 Burr, Charles W.: S. Weir Mitchell Oration, 396
 Burrage, Walter L. (and Howard A. Kelly): *American Medical Biographies*, rev., 306
 Burrell, C. S.: Artificial pneumothorax, 814
 Burridge, W.: Adrenaline in resuscitation, 137
 Burrows, Harold: Bilateral hypoglossal palsy due to gunshot wounds, 776
 Burton-Fanning, F. W.: Five cases of rabbit fever, two cases treated successfully by novarsenuhillon, 886. (O)
 Bury, Judson S.: Gunshot injury to the brain involving both cortical and subcortical tissue, 556. (O)
 Busnell, Col. George E.: *A Study in the Epidemiology of Tuberculosis, with Especial Reference to the Tuberculosis of the Tropics and of the Negro Race*, 570
 Butler, Edwin John, O.I.E. conferred upon, 61
 Button, Martin: The path of toxins to the central nervous system, 853. (O)
 Byers, Sir John W., estate of, 549

- Cambridge diploma in hygiene, 955. *See also* University
- Cambridge and Paul Instrument Company, new lists, 691
- Cambridge women at, 865. *See also* University
- CAMERON, Sir Charles Alexander: Death of, 360—Obituary notice of, 405—*Autobiography of*, rev. 387
- Cameron Lecture. *See* Lecture
- Cameron Prize, 477
- CAMERON, Samuel: Treatment of uterine prolapse, 496
- CAMMIDGE, P. J.: Sapræmic glycosuria, 511
- CAMPBELL, Harry: What is a symptom? 210, 285—Cardiac peristalsis and mitral stenosis, 542—Pulmonary and aortic blood pressure, 719
- CAMPBELL, J. A. C. (and Leonard HILL): Physiological cost of muscular work, 733. (O)
- CAMPBELL, J. M. H.: Exophthalmic goitre, 342
- CAMPBELL, J. Menzies: The Dentists Bill, 403
- CAMPBELL, Robert, memorial to, 98
- Canada: Association for Prevention of Tuberculosis, report, 107—Tuberculosis in the Canadian forces, 680—Canadian anaesthetists meet at Niagara, 856
- Canadian Mother's Book*, rev., 898
- Cancer of breast, ablation of ovaries in, 615
- Cancer of breast, infection of the supra-axillary region in, 175
- Cancer of breast, lines of advance in the surgery of (W. Sampson Handley), 37 (O), 320—Correspondence on, 99, 142, 172, 247, 263, 320, 365, 401, 440
- Cancer of breast, pathology of (Sir G. Lenthal Cheatle), 895
- Cancer cells, differential staining of (A. Geoffrey Spera), 639, 795—Correspondence on, 687, 722, 759, 795
- Cancer, gastric, and gastric ulcer, 99. *See also* Stomach, hour-glass
- Cancer, increase of (parliamentary note), 438
- Cancer of large intestine complicated by amoebic dysentery (Jenner Hoskin), 563
- Cancer of the large intestine (J. Lionel Stretton), 555. (O)
- Cancer of large intestine, survival after operation for (John D. Malcolm), 559. (O)
- Cancer of larynx, usual site of origin of (Sir St. Clair Thomson), 855, 921. (O)
- Cancer mortality, 312
- Cancer, organism cultivated from (James Young), 933
- Cancer prevention and stasis, 31
- Cancer and the public, 472
- Cancer, dual, radio-therapy in (S. Gilbert Scott), 771. (O)
- Cancer, review of books on, 49
- Cancer serum, 206
- Cancer of uterus, inoperable, treatment of (Percival P. Cole), 159
- Cancer of uterus, radium therapy in (A. E. Hayward Pinch), 881. (O)
- Cancer of vagina, primary (Gibbon Fitz-Gibbon), 778
- Cancer, x-ray radiation in, 142, 172, 247, 283, 320, 365, 401, 509. *See also* Cancer of breast
- CANCY, Dr., appointed to the charge of the department of oto-rhino-laryngology in the faculty of medicine at Strasbourg, 795
- Capillary pressure and oedema (Leonard Hill), 767. (O)—Correspondence on, 873, 954
- CAPLAN, S.: Transverse cervical laceration, 421
- Caravan settlement (parliamentary note), 654
- Carbohydrates in excess causing diseases of infants. *See* Infants' diseases
- Carbon dioxide and muscular work. *See* Muscular
- Carbon monoxide, effects of on the eye, 649
- Carcinoma. *See* Cancer
- Cardiac diagnosis (T. Wardrop Griffith), 813
- Cardiac peristalsis and mitral stenosis (D. W. Sandways), 490. (O)—Correspondence on, 542, 688, 719
- Cardiac. *See also* Heart
- Cardiology, clinical, practical gains of since 1900 (W. Gordon), 12. (O)
- Cardiospasm (D. M. Greig), 705
- CAREY, T. V.: Severe tetanus successfully treated by large doses of antitetanic serum, 121
- CARLIER, Dr., death of, 51
- CARMAN, Russell D.: *Röntgen Diagnosis of Diseases of the Alimentary Canal*, rev., 676
- Carnegie United Kingdom Trust, report, 655
- Carnegie Universities Trust, annual meeting, 318
- CAROZZI, Luigi, nominated head of the Service of Hygiene at the International Bureau of Labour, Geneva, 580
- CARPENTER, G. D. Hale: *A Naturalist on Lake Victoria, with an Account of Sleeping Sickness and the Tsetse Fly*, rev., 86
- CARRION (and others): *Sympathique et glandes endocrines*, rev., 463
- CARROLL, Robert S.: *The Soul in Suffering*, rev., 430
- CARRUTHERS, D. A.: dinner and presentation to, 549
- CARTER, Alfred H.: *Elements of Practical Medicine*, rev., 935
- CARTER, H. B. (and W. FLEMING): Case of idiopathic muscular dystrophy, 809. (O)
- CARTER, Rev. J. O. H.: Terminological confusion, 628
- CARTER, Ronald: Congenital syphilis, 460
- CARVER, Alfred E.: Epilepsy considered as a symptom, 102—A herpes-varicella infection, 227. (O)
- CASSELL, Sir Ernest, founds a hospital for functional nervous disorders, 680
- CASSIDY, Louis: Fibrous and muscular attachments of the vagina, 778
- CASTELLANI, Aldo: Treatment of sprue by massive doses of sodium bicarbonate, 338. (O)
- CASTOR, Lieut.-Col. Richard Henderson, obituary notice of, 69
- Casualties and enlistments, war, the gross figures analysed (parliamentary note), 715
- Catalogues, various, 108
- Cataract in ironworkers, 905
- Catarrh, nasopharyngeal, and tuberculosis, 285
- Catch, a, 920
- CATES, Joseph, appointed M.O.H. for Surrey, 178
- CATHCART, George W.: Epididymitis and orchitis from muscular strain, followed by tuberculosis of the epididymis, 193
- Catheter holder for intrauterine treatment of gonorrhoea, 569
- Cattle, vaccination of against tuberculosis (leading article), 130. *See also* Tuberculosis
- CATTLE, C. H.: Mitral stenosis, auricular fibrillation, and the action of digitalis, 521. (O)
- Cauda equina, bullet in (D. H. Vickery), 302
- CAUTLEY, Edmund: Supernumerary nipples, 288
- CAVAZZANI, Emilio: *Le Proteine dell' Orina*, rev., 127
- Cavendish Lecture. *See* Lecture
- CAWSTON, F. G.: Antimony in leprosy, 419. (O)—Control of bilharzia, destruction of mollusca, 479—Treatment of bilharziasis, 650
- CECIL, R. L.: Experimental influenza infection, 94
- Cell activity and specific drug action, 685, 877
- CELLINI, Benvenuto, medical experiences of, 651
- Cement and CO₂, 448
- Census (parliamentary note), 716—Note on, 907
- Cerebral development, review of books on, 529
- Cerebro-spinal fever. *See* Fever
- Cerebro-spinal fluid in encephalitis lethargica (E. Hamar Hodges), 421
- Cerebro-spinal fluid, review of books on, 270
- Cerebro-spinal meningitis, local application of iodine as a prophylactic in (J. A. Taylor), 776. (O)
- Certifying Factory Surgeons' Association. *See* Association
- Cervical defects, 59
- Cervical laceration, transverse (S. Caplan), 421. *See also* Labour
- Cervical ribs. *See* Ribs
- CHACON, Dr., death of, 547
- CHALLENGER, L. T.: Case of tetanus, 228
- CHAMBERS, A. J., memorial to, 95
- CHAMBERS, A. K.: Rats, ships, and crews' quarters, 866
- CHAMBERS, J. E.: Post-herpetic itching, 725
- CHAMBERS, Helen (and others): Action of radium and x rays on tumour growth, 229
- CHAMPNETS, Sir Francis, reappointed by the King to be a member of the General Medical Council, 515
- CHANDLER, F. G.: Albuminuria and life assurance, 84
- "Change of air," 443. *See also* Asthma and anaphylaxis
- CHAPPE, Dr.: *Conjunctivite chez les Artistes du Cinéma*, 233
- CHATTERJI, K. K.: *Syphilis in General Practice, with Special Reference to the Tropics*, rev., 196
- CHAUFFARD, Professor: Statistics of typhoid vaccination, 651
- CHAVASSE, Francis B.: The blood group in mother and child, 641
- CHEATLE, Sir G. Lenthal: Pathological changes in breast epithelium, 895
- Chemical industry, the fine, 153, 315, 347—Circular letter from British firms, 347
- Chemical terms, spelling of, 539
- Chemicals among the key industries (parliamentary note), 753
- Chemistry, review of books on, 464
- Chemists' exhibition, 960
- Cheshire tuberculosis scheme, criticism of, 910
- CHESSER, Elizabeth Sloan: Irritable bladder, 544
- CHESNEY, Lillian Mary, Serbian Order of St. Sava conferred upon, 446
- Chicago druggists allowed to draw 200 gallons of whisky and 200 gallons of wine every three months, 795
- Chicken-pox, compulsory notification of in Scotland, 661
- Childbirth and lactation, 448
- Child welfare. *See* Maternity and child welfare
- CHILDE, Charles P.: Surgery of breast cancer, 401, 440
- Children born in France, premium for, 914
- Children's and infants' diseases, review of books on, 531, 565, 934
- China: Advance of medical education in, 308, 313—Medical service on river gunboats (parliamentary note), 475—Opium supply from India, 438—Opium cultivation in (parliamentary note), 438, 505—Red Cross Society report, 615
- Chinese flour (parliamentary note), 316
- Chinese honours for medical missionaries, 208
- CHISHOLM, Archibald: *Labour's Magna Charta*, 748
- Cholecystectomy, indications for K. W. Molsarrat, 371. (O)
- Cholera, hypertonic saline in treatment of (Sir Leonard Rogers), 673
- Cholera, kaolin in treatment of (R. R. Walker), 640
- Cholera in Corea, 761
- CHRISTOPHERSON, J. B.: Bilharzia disease in Egypt, 491. (O)
- CHURCH, Gilbert: Operation for the radical cure of pre-masseteric fistulae of Stenson's duct, 45. (O)
- Cinema, the retarded, 287, 359; and cardiac action, 402
- Cinematograph, the, and eyestrain, 233, 281, 322. *See also* Cinematograph
- Circulation in acute infection (Esther Harding), 462
- Circulation, recent advances in the physiology of (J. S. Haldane), 409 (O)—Leading article on, 432
- Civil assistant surgeons (India), 755
- Civil Service Estimates, 575
- Civil work, application of war lessons to (Sir Henry M. W. Gray), 62, 109. (O)
- Civilian practice, self-inflicted injuries in (A. Reade Short and Cyril H. Walker), 298. (O)
- CLARK, G. Herbert: Treatment of gastric and duodenal ulcers, 122
- CLARKE, John S.: Supernumerary nipples, 370
- CLAYTON-GREENE, W. H.: The private clinic, 939
- CLAYTON-JONES, O.: Chronic retention of urine arising from prostatic disorder, 441
- CLEARE, A. E.: *Dangerous Drugs Act, 190*
- Cleft palate, congenital, new principle in treatment of (H. D. Gillies and W. Kelsey Fry), 335 (O). *See also* Palate
- CLIFFORD, Sir Hugh: Treatment of trypanosomiasis, 777
- CLIFTON, Robert Bellamy, death of, 368
- Climate of the Riviera, 586
- Clinic system, the private, discussion at Royal Society of Medicine, 937
- Clinician, the pure, 913. *See also* General practitioner
- CLIPPINGDALE, S. D.: Transfixion of the body, 550
- Club, East of Scotland Overseas Medical, dinner, 318
- Club, Newcastle Glasgow University, dinner, 718
- Club, Sheffield Edinburgh University, dinner, 317
- Club, Southend Doctors' Cricket, 448
- COATES, Colonel William, Belgian Ordre de la Couronne conferred upon, 253
- COATES, W. H.: The sarcoptic mange of the dog in man, 495
- COBE Ivo Geikie: *A Manual of Neurasthenia (Nervous Exhaustion)*, rev. 50
- COBB, Lieut.-Col. Robert, obituary notice of, 446
- Coccygeal fistulae. *See* Fistulae
- COCKER, Albert B.: Ethanesal anaesthesia, 659
- Cockroach, the, 614
- COBRINGTON, Deputy Surgeon-General Oliver, obituary notice of, 626, 690
- COKE, Frank: Asthma and anaphylaxis, 372 (O), 581—Pruritus ani, 603
- CORNING, A. J.: Unusual case of myelocoele, 380. (O)
- COLE, Percival P.: Treatment of inoperable uterine carcinoma, 159
- COLERBROOK L. (and Captain S. R. DOUGLAS and A. FLEMING): Studies in wound infections, 235
- Colectomy for intestinal stasis, results of (A. W. Sheen), 116 (O). *See also* Hemicolectomy
- COLEMAN, Robert B.: Case of cardiac massage, 47—(and F. O. LABREY): Bilharziasis treated by antimony tartrate, 299. (O)
- Colitis, diagnosis and treatment of, 525
- Collective opinion of the profession. *See* Medical profession
- College, Epsom, "France" pensions, 287
- College, Gordon Memorial, Khartoum, report, 121
- College, Livingstone: New principal, 655—Commemoration Day, 840
- College of Nursing, Cavendish Square site, 253
- College of Physicians of Philadelphia: Report of Library Committee, 676—Presentation from Madame Curie, 879—Presentation of mementoes of Lister and Pasteur, 879
- College, Royal Army Medical, London: A Professor of Military Medical History at, 244, 323. *See also* Military medical history
- College, Royal, of Physicians, of Edinburgh: Parkin prize, 252
- College, Royal, of Physicians of Ireland: Election of Fellows, 547, 761—Degrees and pass lists, 547

COLLEGE, ROYAL, OF PHYSICIANS, OF LONDON.
Académie de Médecine centenary, 214
Annual address, 514
Appointments, 958
Comitia, 214, 252, 514, 689, 761, 958
Communications, 252, 958
Council election, 214
Degrees and pass lists, 214, 252, 690
Diplomas, 214, 514, 690, 761
Diseases of children, adequate training in to be necessary for the conjoint diploma, 958
Election of President, 514
Fellows elected, 761
General Medical Council, 214
Gifts, 761
Harveian oration, 214
Lectures, 214
Licences, 252, 514, 690
Members admitted, 214, 689

College, Royal, of Surgeons, of Edinburgh:
Bathgate memorial prize, 794—Degrees and pass lists, 794—Fellowship examination, 794

COLLEGE, ROYAL, OF SURGEONS OF ENGLAND:
Appointments, 626, 918
Central Midwives Board, 286
Council election, 286, 446, 480, 515
Council meeting, 145, 286, 446, 761
Court of Examiners, 761, 918
Degrees and pass lists, 145, 252, 286, 794, 918
Dentists Bill, 446
Diplomas, 286, 761
Examiners appointed, 918
Fees, alteration in, 145
Fellowship, 626, 918
French Academy of Medicine centenary, 145
Honorary Fellows, 135, 281
Hunterian Festival, 281
Hunterian Lectures, 176, 214
Hunterian Oration, 214, 274
Lectures, 176, 214, 252, 918
Onodi collection of nasal anatomy, 145, 210
Primary Fellowship, 794
Prince of Wales elected an Honorary Fellow, 135, 281
Prizes, 626
Professors and lecturers for the ensuing year, 918

College, Royal, of Surgeons in Ireland: Honour for American surgeons, 660—Honorary Fellows, 918—Pass lists and degrees, 918

College, Trinity, Dublin: Degrees and pass lists, 547, 659. *See also* University

College, University, Johannesburg: Appointments, 691

College, University, London: *Calendar*, 197—Lectures, 761

COLLIER, H. W.: Albuminuria and life assurance, 81—An acid diuretic, 550

COLLINGWOOD, B. J.: The Physiological Laboratory of the University of London, 285

COLLINS, Sir William, appointed chairman of Central Council for District Nursing in London, 407

COLLIS, E. L. (and M. GREENWOOD): *The Health of the Industrial Worker*, rev., 497

Cologne, health of soldiers at (parliamentary note), 438. *See also* Venereal

Colon, appendix communicating with, 146

Colonial Medical Services (parliamentary note), 869

Colonies, Crown, venereal diseases in, 716

COMBES, Emile, obituary notice of, 826

Communicable diseases, review of book on, 568

Comparative medicine, 356

Complement fixation tests in the diagnosis of tuberculous infections (Arthur Sellers and E. N. Ramsbottom), 47

CONCETTI, Luigi, death of, 215

Conditions of Practice Abroad, Report on, 273

Conference, British Pharmaceutical: The future of pharmacy, 948

Conference, Red Cross. *See* Red Cross

Conference on tuberculosis. *See* Tuberculosis

CONGRÈS de Chirurgie at Strasbourg, October, 1921: Medal to be presented to E. Boeckel, 739

Congress for Childhood Protection, 919

Congress, Dutch, of Public Health, 919

Congress of Eugenics, International: Second meeting to be held in New York in September, 215, 468

Congress, French, of Medical Jurisprudence, 677

Congress, German, of Internal Medicine, 919

Congress of German Orthopaedic Society, 562

Congress of Gynaecology and Obstetrics, British, 795

Congress on the History of Medicine, International, Paris (August, 1921), 107, 482, 750, 879, 950. *See also* Medical history

Congress on Infant Welfare, London (1921), 23

Congress of Italian Sanitary Industries, 583

Congress of the Italian Society of the History of Medical and Natural Sciences, 253

Congress, Labour, International, 431

Congress, Medical: To be held at Helsingfors, 840—Principal subject of discussion to be syphilis, 840

Congress of Military Medicine, 473

Congress of Obstetrics and Gynaecology, British: First meeting, 892—End-results of plastic vaginal operations for genital prolapse, 892—Demonstrations, 891—Dinner, 895

Congress of Ophthalmology, International, to be held at Washington, 919

Congress, Oxford Ophthalmological, 241, 949

Congress of Pathology, International, postponed indefinitely, 368

Congress in Radiology, Bilingual, 28

Congress of Radiology and Physiotherapy, 205, 398, 471, 616—Postponed, 616

Congress, Red Cross, 503. *See also* Red Cross

Congress of School Hygiene, 317

Congress, Sicilian Medical, 482

Congress, South African Medical, 959

Congress of Union of International Association of Brain Workers, 927

Congress of Urology, International, 745

Congress on Venereal Diseases, American, 90

Conjoint Board in Ireland: Degrees and pass lists, 761

Conjoint Board in Scotland: Degrees and pass lists, 214, 626, 761, 794

CONNOLLY, Deputy Inspector-General Nicholas Thomas, obituary notice of, 548

CONRAN, Philip: Intermittency of trypanosomiasis, 916

Constitutional problem (leading article), 647

Consultants' letters, 512

Consultative Council, Scottish: Medical service scheme, 208

COOKSON, Surgeon-Major Henry, obituary notice of, 840

COOMBS, Carey F. Persistence of the ductus arteriosus, 138

COOPE, Robert: Faeces in alimentary disorders, 528

COOPER, Astley, and Hunterian principles (Sir Charters J. Symonds), 274

COPE, Zachary: *Surgical Aspects of Dysentery, including Liver Abscess*, rev., 498

COPEMAN, A. H.: Cure of haemorrhoids without operation, 365

CORBET, William: Fatal poisoning from acid fumes, 404

CORBETT, Catherine Louise, Serbian Order of St Sava conferred upon, 446

Corea, cholera in, 761

CORKER, Major-General T. M.: Venereal disease prevention, 247

CORNER, Edred M.: Light metal limbs in above-knee amputations, 524. (O)

Coroners, London, payment of, 427

Coroners' Remuneration Bill, 505, 576, 908

Corrections, 36, 70, 408, 625, 528

Correspondence:

Abdominal effusions, acute, early diagnosis of, 759

Acid fumes, fatal poisoning from, 404

Acidosis and alkalosis, 508, 542

Adenoids, medical treatment of, 285

Adrenaline in resuscitation, 100, 136, 544, 582—A disclaimer, 100. *See also* Resuscitation

Age and pensions, 249

Anatomy and physiology, teaching of, 143

Angio-neurotic oedema, 480, 545: treated by injections of horse serum, 68, 102

Aphasia, a new study of, 913

Arms, position of the arms in breech with extended legs, 320, 366, 444, 624

Artificial eye, care of, 685

Artificial legs, 103

Asthma and anaphylaxis, 478, 511, 581

Beginnings of life, 64, 103, 141

Bibliographical references, 479

Bilharzia control, destruction of mollusca, 479

Bladder, irritable, 480, 511, 544, 582, 659, 688

Blood transfusion in haemorrhagic disease of the newborn, 791

Bradford Municipal General Hospital, 171, 212, 245

Breath presentation. *See* Arms, extended

British aid for men of letters and science in Russia, 65, 250

Cambridge diploma in hygiene, 956

Cancer of breast, lines of advance in the surgery of, 99, 173, 320, 365, 401, 440

Cancer prevention and stasis, 31

Cancer and X rays. *See* X ray

Capillary pressure, 873, 954

Carcinomata, differential staining of, 687, 722, 759

Cardiac peristalsis and mitral stenosis, 542, 688, 719

Catarrh, nasopharyngeal, and tuberculosis, 285

Cell activity and specific drug action, 685, 877

"Change of air," 443

Chemia, retarded, and cardiac action, 402

Clinician, a pure, 913

Coccygeal fistulae, 915, 957

Collective opinion of the profession, 322, 362, 543

Consultants' letters, 512

Criminal Law Amendment Bill, Clause 7 of, 101

Dentists Bill, 511

Dextrose in cardiac failure, 244

Drooping shoulder sign of phthisis, 248, 367, 441. *See also* Tuberculosis

Ductus arteriosus, persistence of, 138, 175

Eclipse blindness, 756, 837

Empyema, site of operation for, 657, 719, 759, 836

Encephalitis, epidemic, "minute bodies" in, 210

Encephalitis lethargica, Ministry of Health memorandum on, 508

Correspondence (continued):

Encephalitis lethargica, past appearances of, 478

Encephalitis lethargica, prognosis in, 172

Epilepsy considered as a symptom, 102, 444

"Ethanesal" or "ether," 622

Ethanesal anaesthesia, 658

Etiology, the science of, or the new epidemiology, 581, 622, 658

Evelyn, John, and medicine, 623

Evolution in relation to disease, 543, 622, 721

Eye-strain in cinematograph hall, 322

Fat-soluble "A" content of oils, 104

Fatal poisoning from inhalation of acid fumes, 143

Fracture of the first rib, 284

Gastric ulcer and gastric cancer, 99

Glandular fever, 100, 142, 509, 546, 582

Glandular and pulmonary tuberculosis, 213

Glycosuria, sapraemic, 511, 687

Goitre in school children, simple, 367, 444

Haemorrhoids cured without operation, 364, 402, 441, 479

Herlequin foetus, 623

Health Ministry and the profession, 31, 64, 99

Health service for London, co-operative, suggestions for a, 244

Heart-block, 877, 956

Heart-block and the Adams-Stokes syndrome, 755, 791

Heart-block in diphtheria, 621

Heart disease, study of, 34, 143

Hemicolectomy, 213

Herpes and varicella, 284

Hospital staffs and paying patients, 31, 98

Hospitals, voluntary, and the Bradford bogey, 98, 137, 171

Hospitals, Voluntary, Committee, 956

Hospitals, voluntary, conference on, 66, 366

Intestinal protozoa, endemicity of, 363

Mackenzie's theory of disturbed reflexes. *See* Symptoms

Medical registration, 583

Military medical history, professor of at the R. A. M. College, London, 244, 323

Ministry of Health and the profession. *See* Health

Muscle re-education in infantile paralysis, 33, 67, 175

Napoleon and Murat, 722

Nasopharyngeal catarrh. *See* Catarrh

Naval Medical Service, 67, 143, 176, 248, 285, 323

Newton, the late Dr., Stoke-on-Trent, 512

North European Conference on Venereal Diseases, 957

Notification fee and the end of the war, 916

Operations performed under difficulties, 622

Pathological museum at the Annual Meeting, 957

Physiology and clinical medicine in Sheffield, 688

Prostate, enlarged, treatment of the post-operative stage of, 142, 211, 322

Prostatic congestion, 688. *See also* Bladder

Prostatic symptoms and their causes, 545, 625

Pruritus ani, 659

Psychology, elementary, in general hospital teaching, 793

Puerperal infection, prevention of, 404, 479, 757, 791, 837, 873, 914

Pulmonary and aortic blood pressures, 688, 719

Pure clinician, 913

Refraction work among school children, 759, 792, 838, 875, 914

Resuscitation of the apparently dead and the relation of cardiac innervation to it, 136. *See also* Adrenaline

Rickets, etiology of, 685

Salvarsan and the Wassermann test, 582

School ophthalmic work, 876, 915

Science, what is "954"

Scientific papers, the preparation of, 720, 756, 793, 873, 913

Scurvy in a breast-fed infant, 583

South Africa and the British Medical Association, 363

Spina bifida, 480

Stages' antlers and evolution, 247

Stasis and cancer. *See* Cancer

Symptom, what is a? 210, 243, 283

Symptoms, production of, 210, 243

Testis, descent of the, 687

Tonsils and adeoids in outdoor clinics, risks after operation for, 32, 65, 101, 140, 174, 213, 245, 321, 365, 404, 443

Tonsils, enucleation of, 916

Toxaemia, acute, the treatment of, 855, 953

Transition of the body, 581

Tropical Diseases Prevention, Committee for, 512

Tropical medicine, future of research in, 542, 834

Trypanosomiasis, intermissions in, 916

Tuberculosis administration, defects in, 839, 913

Tuberculosis, bovine, 544

Tuberculosis death rate, the fall in, 322, 443, 510

Tuberculosis, drooping shoulder sign of, 248, 367, 441

Tuberculosis mortality, 510

Tuberculosis and nasopharyngeal catarrh, 85

Correspondence (continued):

- Tuberculosis, pulmonary, a new sign of, 285
Tuberculosis, search for a specific cure for, 402
Tuberculous milk, 34, 141, 174
University of London: Physiological laboratory, 283
Urine, chronic retention of arising from prostatic disorder, 441, 544
Vaccine therapy in regard to general practice, 320
Venereal disease prevention, 100, 139, 174, 211, 245, 284, 323, 404, 443, 684, 758
Venereal disease prophylaxis, 32, 66, 100
Venereal disease treatment, 686
Vitamins and dental caries, 837
Voluntary hospitals. *See* Hospitals
Voluntary principle and the Bradford hodgey, 98. *See also* Hospitals
Wassermann reaction, value of, 658, 686, 719
What is science? *See* Science
Willesden municipal clinics and hospital, 171
X-ray radiation in cancer, 142, 172, 247, 283, 320, 365, 401, 440, 509
X rays for ringworm, the risk of baldness, 32
- CORRY, S. L.: Seven great-grandparents alive, 370
CORTEZO, C. M.: monument to, 930
CORY, W. Howard: Puerperal infection, 479
COSENS, W. B.: Prevention of puerperal infection, 838
COSTELLO, D. (and W. M. CROFTON): Encephalitis lethargica treated with influenza bacillus antigen, 601
COTTENOT, BÉCLÈRE, and LABORDE: *Radiologie et Radiumthérapie*, rev., 676
Council of British Ophthalmologists: Report, 762
Council, General Medical: Revocation of order re Belgian qualifications and the Medical Register, 60—Report on Conditions of Practice Abroad, 273—Minutes, rev., 347—General Index to Minutes, rev., 347
- COUNCIL, LONDON COUNTY:
And Medical women, 400
Coroners, payment of, 427
Eyestrain in cinematograph halls, 281
Health of London, report of M.O.H., 833
Institutional treatment of tuberculosis, 506
London University site, 275
Medical treatment of school children, 30
Milk, tuberculous, 302—Aud training of pupil midwives, 63
Tramway accident claims: Three medical officers appointed, 287
Transmigrants, accommodation for, 202
Venereal clinics arrangements, 506
- Counsels and Ideals*, 947
County councils and tuberculosis treatment (parliamentary note), 576
County Maternity Home. *See* Maternity
COURTADE, D.: *Notions Pratiques d'Electrothérapie appliquée à l'Urologie*, rev., 781
COUSLAND, Philip B., Chinese Order of Chia Ho conferred upon, 208
COWAN, John: Treatment of gastric and duodenal ulcers, 122
COX, Neville: Artificial pneumothorax, 814
Cox Cavendish Electrical Co. amalgamate with X Rays, Ltd., 370
Cozzolino collection of anatomical and pathological specimens presented to oto-rhinolaryngological clinic of Naples, 387
CRAGO, W. H., appreciation of S. T. Knaggs, 878
CRAIG, James, knighthood conferred upon, 652
CRAIG, John: An operation for retroflexion of the uterus, 659
CRAIG, Maurice, knighthood conferred upon, 96—Dinner to, 325
CRAIK, Robert: The beginnings of life, 103—An unusually virulent variety of microsporion, 672
CRAWFORD, Margaret (or Margaret de Lancy Williams), summoned for an offence under the Medical Acts, 215, 324
CRAWFORD W. J.: *The Psychic Structures at the Golgiher Crete*, rev., 703
CRAWSHAW, C. H. (and A. H. SOUTHAM): Reaction of intestine for acute intussusception, two cases of recovery, 266. (O)
CREIGHTON, Charles: *Some Conclusions on Cancer*, rev., 49
Crenation in England, report, 236
CRETINS, photographs of, 574
CREW, F. A. E.: Descent of the testis, 687
CRIDLAND: Cataract in ironworkers, 905
CRILE, G. W. (and W. F. LOWER): *Surgical Shock and the Shockless Operation through Anoc-association*, rev., 385
Criminal Law Amendment Bill, Clause 7 of, 101—The Bishop of London's Bill, 437—In the House of Lords, 474—Parliamentary note, 618, 951
Cripples, conference on the care of, 958
CRITCHLEY, H. G.: Refraction work in children, 838
CROCKET, James: Tuberculin in epilepsy, 458 (O)
CROFTON, W. M. (and D. COSTELLO): Encephalitis lethargica treated with influenza bacillus antigen, 601—The pure clinician, 913
CROOKSHANK, F. G.: Past appearances of encephalitis lethargica, 478—Ministry of Health memorandum on encephalitis lethargica, 508—A new study of aphasia, 913
CROOM, Sir Halliday, resignation of, 946
CROSSO of Norwich, John Greene, diary of, 232
CROSSEN, Harry Sturgeon: *Operative Gynaecology*, rev., 163
CROUCHER, A. H.: The search for a specific treatment of tuberculosis, 307
Crown Colonies. *See* Colonies
CRUCHET, René (and René MOULNIER): *Le Mal des Aviateurs: Ses Causes et ses Remèdes*, rev., 18—English edition, 63
CUFF, Cyril H.: Surgical uses of the fascia lata, 494. (O)
CULLEN, James Arthur William, obituary notice of, 446
CULLEN, Major William Barbour A. K., obituary notice of, 626
CULPIN, Milais: *Psychoneuroses of War and Peace*, rev., 125
Culture, the primary organism in (Captain C. B. Dyson), 932
CUMBERBATCH, Elkin P.: *Diathermy, its Production and Uses in Medicine and Surgery*, rev., 643
Cumberland Tuberculosis Colony, 54
CUMMING, Captain Robert Scott, obituary notice of, 626
CUMMINS, Colonel S. Lyle: Assumes duty as Professor of Tuberculosis at University College, Cardiff, 253—Eradication of tuberculosis, 422
CURIE, Madame, presented with a gram of radium by the women of the United States, 795
CYRIAX, Edgar F.: Muscle re-education in infantile paralysis, 67
Cyst of brain (Mr. Newbolt), 705
Cystoscopy, uses and limitations of (Mr. Newbolt), 705
Czecho-Slovakia: Public health of, 278, 311—Red Cross organizes country colonies for children and a children's hospital, 781
- D.
- "D.A.H." *See* Heart, disordered action of
D.P.H., course for at Bradford, 368
DA FANO, C.: Histo-pathology of epidemic (lethargic) encephalitis, 153. (O)
DAKIN, W. R., Cross of the Legion of Honour conferred upon, 584
DALE, H. H.: Use of alcohol in medicine, 608—Anaphylaxis and immunity, 820
DALZELL-HUNTER, Major John B., O.B.E. conferred upon 958
DALZIEL, Sir Kennedy: Treatment of gastric and duodenal ulcers, 122
DANA, Charles L.: *Poetry and the Doctors*, 276
DANDY, W. E.: Hydrocephalus in chondrodystrophy, 435
DANE, Paul G.: Results of nerve suture, 885. (O)
Dangerous drugs. *See* Drugs
D'ARSONVAL, M.: The search for a specific treatment of tuberculosis, 307
DARWIN, Ruth, appointed a commissioner of the Board of Control, 585
DAVENPORT, Cecil J., Chinese Order of Chia Ho conferred upon, 208
DAVIDSON, Lieut.-Col. David Macdonald, C.I.E. conferred upon, 62
DAVIDSON, Isaac A.: Care of artificial eyes, 685
DAVIE, T. M., called to the Bar, 661
DAVIES, Sidney: The fall in the tuberculosis death rate, 322
DAVIES-JONES, Hugh, obituary notice of, 917
DAVIS, Edward D. D.: Risks after operations on tonsils and adenoids in outdoor clinics, 443—Anaphylaxis and immunity, 820
DAVIS, Edward P.: *Mother and Child*, rev., 818
DAVIS, F. L.: Argo-neurotic oedema, 490
DAVIS, Hugh A.: Diaphragmatic hernia, 880
DAVIS, Hen John W.: *The Constitution of the United States*, rev., 607
DAVIS, Oliver C. M.: Irritable bladder, 659
Daylight Saving Act: Effect of on young children, Board of Education circular, 840—Parliamentary note, 840
DAYUS Frederick Herbert, obituary notice of, 250, 288
Dead body. *See* Body
DEARDEN, W. F.: Appreciation of C. A. Greaves, 760
DEARE Lieut.-Col. Benjamin Hobbs, C.I.E. conferred upon, 865
Death, pre-natal (leading article), 785
Decerebrate rigidity in man, 359
DE DECKER, G. (and A. D. WALLER): Physiological cost of muscular work measured by the exhalation of carbon dioxide, 669. (O)
Defaecation, posture in, 36
Defence Force. *See* Army, British
Deficiency disease, review of book on, 896
Deformities, postural or so-called static (A. S. Blundell Bankart), 587, 636 (O)
DELANT, Lieut.-Col. Thomas Henry, obituary notice of, 253
Delhi boil. *See* Leishmaniasis, local
DELITALA, F.: *Gli Apparecchi Ortopedici*, rev., 606
Delivery of child and placenta in unruptured membranes at term, 108
Delivery, normal, after traumatic rupture of uterus (R. Thorne Thorne), 459
Deliv ry. *See* Labour
Denmark, new pharmacopoeia, 661
DENNISON, Arthur, obituary notice of, 625
Dental caries, appendicitis, and gastric ulcer, 960
Dental caries and vitamins, 837
Dental practice abroad, report on conditions of, 272
Dental service of the Navy. *See* Navy
Dentifrice, an acid, 408, 550—An alkaline, 692, 726
Dentista Bill, 29, 361, 408, 438, 511, 618, 682, 715, 868, 908, 950
Dentists' Register, rev., 708
DENER, Stanley E. (and D. E. MORLEY): Case of myoclonic encephalitis lethargica simulating hydrophobia, 191. (O)—Dextrose in cardiac failure, 248
De Pezzer tube in suprapubic drainage of bladder (G. S. Motherhill and Clifford Morson), 418 (O)
DEPIERRE, Dr., death of, 253
Derbyshire, venereal disease campaign in, 718
Dermatitis caused by a bitter orange (F. Anderson Murray), 739
Dermatology, review of books on, 567, 676. *See also* Skin
DESPOSSE, P. (and others): *Chirurgie Réparatrice et Orthopédique*, rev., 16
Dextrose in cardiac failure (G. Scott MacGregor), 158—Correspondence on, 248
Diabetes, bronzed, and haemochromatosis (Robert Muir), 461
Diabetes insipidus and the pituitary, 238
Diabetes, ophthalmoscopic appearances in certain rare cases of (R. T. Williamson), 120
Diabetes, renal (Adam Patrick), 779
Diabetes, review of book on, 858
Diabetic acid tests, 841
DIAMANTIS, Dr.: Emetine in bilharziasis, 7
Diamond industry and disabled soldiers, 358
Diaphragm, congenital deficiency of (George S. Barnett), 602
Diathermy for inoperable growths (Sir William Milligan), 461, 855
Diathermy in diseases of the throat and nose (W. J. Harrison), 220. (O)
Diathermy, review of books on, 643
Dibothrocephalus latus infection, case of (George C. Low and Elizabeth O'Driscoll), 118 (O). *See also* Tapeworm
Dick, Walter: Glandular fever, 546
DICKIE, W. S.: The private clinic system, 339
DICKINSON, W. H.: Glandular and pulmonary tuberculosis, 213
DICKSON, Kenneth: Value of the Wassermann reaction, 638
Dictionary, French-English Medical (A. Gordon), 335
Dictionary, Stedman's, rev., 781
Diet, influence of on the teeth (Dr. Handley Read), 385
Diets, meatless, 906
DIGGLE, F. Holt: Risks after operation for tonsils and adenoids in outdoor clinics, 32—Chronic suppurative otitis media followed by left temporo-sphenoidal abscess and meningitis, 600. (O)
Digitalis, action of, and mitral stenosis and auricular fibrillation (C. H. Cattle), 521. (O)
Digitalis in auricular fibrillation, value of (J. D. Harris), 49
DINMOCK, Lieut.-Col. Henry Peers, obituary notice of, 286
Diphtheria bacillus, isolation of (Denys R. Wood), 562 (O)
Diphtheria carriers, 27
Diphtheria and follicular tonsillitis (W. H. Palmer), 527
Diphtheria, complete heart-block in a case of (R. Clayton Allen), 267. (O)—Correspondence on, 321
Diphtheria, the Schick reaction (Gladys Ward), 928. (O)
Diphtheria-like organisms, virulence of (A. J. Eagleton and E. M. Baxter), 775. (O)
Disability pensions. *See* Pensions
Disabled ex-service men: Hospital facilities for in America, 890—In England (parliamentary note), 909—International Labour Bureau's figures on number of, 919
Disabled Society issues a pamphlet for general guidance of ex-service men who have lost a limb, 307
Disabled soldiers and the diamond industry, 358
Discharged soldiers and insurance benefit (parliamentary note), 909
Disclaimers, 100, 550
Disease prevention, the part of the State in (Christopher Addison), 940
Disease symptoms: Theory of disturbed reflexes in the production of (Sir James Mackenzie), 147. (O)—Correspondence on, 210, 243, 283
Diseases of infants due to excess of carbohydrates (C. E. Bloch), 293. (O)
Dislocations, habitual (Laming Evans), 383—Discussion, 384
Dispatches from the Black Sea Army, 144—*See also* Honours
District nursing in London, 361—Appointment of officers, 407

- Divisional and full-time health insurance officers (parliamentary note), 61
- DIXEY, H. E., appointed sheriff for County of Worcester, 447
- DIXON, W. E.: *Practical Pharmacology*, rev., 87
- DORBS, Arthur Francis, obituary notice of, 660
- DOBELL, Clifford: Intestinal protozoa endemic in Britain, 276
- DORIE, D. Robertson: Pregnancy and labour in a double uterus, 16
- DOBSON, J. F.: Arris and Gale lecture on the function of the kidneys in enlargement of the prostate gland, 289 (O)
- Doctor, bogns, in Glasgow, 684
- DODDS, E. C.: Chemical estimation of gastric function, 383
- Dogs Bill, 316, 618, 869
- DOLLING, Charles Edward, case of, 170
- DON, Alexander: Prevention of intestinal obstruction after ventrofixation, 563
- DON, James, presentation to, 234
- DONALD, Archibald, appointed Deputy-Lieutenant for Lancashire, 833
- DONDERS, Franciscus Cornelius, monument to, 959
- DONKIN, Sir H. Bryan: Venereal disease prevention, 100, 758—Treatment of acute toxæmia, 953
- DONOVAN, Lieut.-Col. C.: Treatment of local leishmaniasis, 302
- DOORLY, A. R. C.: Patent ductus arteriosus, 175
- DOTT, Norman M.: Cardiac massage in resuscitation, 192
- DOUGLAS, Captain S. R. (and A. FLEMING and A. COLEBROOK): Studies in wound infections, 235
- DOUGLASS, Major J. H., called to the Bar, 661
- DOWDEN, J. W.: Treatment of fractures of the upper extremity, 896
- Draining rack, the "Rycott," 781
- Dreams of children, 906
- DREW, H. V.: Lumbar puncture in acute disease, 326—Toxins and nerve centres, 920
- DREYER, Georges, elected Fellow Royal Society, 357—The serum diagnosis of syphilis, 859, 950
- Dreyer-Ward method of serum diagnosis of syphilis, 859, 950
- Drooping shoulder. *See* Tuberculosis
- Drug action, specific, and cell activity, 625
- Drug list, modernized, 448
- Drugs Act, the dangerous: Regulations under, 96, 240, 789 Correspondence on, 180—Parliamentary notes on, 315, 360, 398, 474, 715, 753—Farmers and, 361—Ireland and, 950
- Drugs, dangerous, in India (parliamentary note), 438
- Drugs, therapeutical value of, German institute for testing, 745
- DRUMMOND, J. C.: Nutritive value of lard, 502
- DRURY, H. (and Sir Arthur BALL): Case of plague in Dublin, 84
- Dublin: Case of plague in (H Drury and Sir Arthur Ball), 84—Wounded persons in the hospitals, 209, 319—Associated hospitals' fees, 439
- Ductless glands. *See* Glands
- Ductus arteriosus, patent (E. Wilson Hall), 83—Correspondence on, 138, 175
- DUDGEON, L. S.: Backwater fever, 94
- DUDLEY, Surgeon-Commander S. F.: The influenza epidemic in the navy, 705
- DUFOUR, M.: Instruction of medical students in physics, 134
- DUNCAN, Alexander, obituary notice of, 324
- DUNCAN, Percy J.: The late Peter Thomas Duncan: a correction, 625
- DUNCAN, Peter Thomas, obituary notice of, 583, 624
- DENCOMBE, Adolphus: Guild of Blind Gardeners, 692
- DUNDERDALE, Evelyn (and E. H. R. HARRIES): Herpes and varicella, 600, (O)
- DUNHILL, T. P.: Exophthalmic goitre, 269, 426
- DUNLOP, Knight (and Robert M. YERKES, editors): *The Journal of Comparative Pathology*, rev., 818
- DUNLOP, James Craufurd, appointed Registrar-General for Scotland, 136
- DUNN, W. E. Nickolls: Dental caries, appendicitis, and gastric ulcer, 960
- DURET, Henri, obituary notice of, 689
- DUTCH, Henry: A urethral drainage bougie, 645
- DWYER, F. Conway, knighthood conferred upon, 365
- Dyestuffs (Import Regulation) Act, list of products, 447
- DYER, Sidney Reginald, appointed a Commissioner of Prisons, 626
- DYKE, S. C.: Suggested autoinoculation of a rodent ulcer, 932 (O)
- DYKES, H. P. (and Edwin BRAMWELL): Cervical ribs and pressure symptoms, 384
- Dysentery, amoebic, complicating malignant disease of lower bowel (Jenner Hoskin), 563
- Dysentery, review of books on, 498
- DYSON, Captain C. B.: The primary organism in culture, 932
- Dyatrophy, idiopathic muscular (H. S. Carter and W. Fleming), 809, (O)
- E.
- EAGLETON, A. J. (and E. M. BAXTER): Virulence of diphtheria-like organisms, 775, (O)
- EALDES, G. Young: Herpes and varicella, 340
- Ear disease, review of books on, 463
- EARLE, H. G.: Exophthalmic goitre, 342
- East of Scotland Overseas Club. *See* Club
- ECCLES, W. McAdam: Early diagnosis of acute abdominal affections, 663, (O) Pathology of breast epithelium, 895
- ECKENSTEIN, Kenneth E., Legion of Honour conferred upon, 795
- Eclampsia, etiology of, and the pre-eclamptic state (James Young and Douglas A. Miller), 486, (O)
- Eclampsia, hæmorrhage with (Dr. Fordyce and R. W. Johnstone), 496
- Eclipse blindness. *See* Blindness
- Ectopia vesicæ successfully treated by transplantation of the tritone into the sigmoid (Herbert H. Brown), 15
- Eczema, infantile: ? *Staphylococcus* vaccines for, 919
- EDEN, T. W.: Operative treatment of genital prolapse, 894
- EDGE, Frederick: Prevention of puerperal fever, 875
- Edinburgh. *See* Scotland
- EDINGTON, G. H.: Thoracic duct wounded during removal of tuberculous cervical glands, 564
- Edison-Swan Electric Company, catalogue, 108
- Edmonds prize in ophthalmology, 28. *See also* Ophthalmology
- EDWARD VI, the birth of, 788
- EDWARDS, Tudor (and Ivor BACK): *Surgery*, rev., 429
- EDWARDS, Major-General Sir William Rice, K. C. I. E. conferred upon, 865
- Efficiency Exhibition, 279
- Egypt: Bilharzia disease in (J. B. Christopherson), 491 (O)—Ophthalmic work in, report on, 505 plague in, 661—Akylostomiasis campaign in (A. F. MacCallan), 674—Hospital to be erected in the Isle of Rhodes, 717
- Egg-powders, composition of, 919
- Egypt, ancient, the medicine of, 472
- Einstein's theory of relativity to be published in *Nature*, 253
- Elbow, modern surgery of (R. Atkinson Stoney), 48, 180
- Elbow, tennis, 146
- Electricity in the destruction of bacilli (P. C. Collingwood Fenwick), 812
- Electro-cardiograph (Isaac Harris), 704. *See also* Heart-block
- Electrology and radiology, teaching of, 164
- Electrolysis in treatment of hæmorrhoids (J. Curtis Webb), 457, (O)
- Electro-medical industry, combination in, 370
- ELIASON, Eldridge L.: *First Aid in Emergencies*, rev., 87
- ELLINGTON, George A.: Herpes and varicella, 831
- ELLOR, Colonel R. H.: Treatment of trypanosomiasis, 777—*The Care of Eye Cases*, rev., 934
- ELLIOTT, E. L.: Herpes and varicella, 302
- ELLIS, William Henry, obituary notice of, 760
- ELLISTON, G. S.: Tuberculous milk, 174
- ELYS, J. C.: Artificial lighting for cinematography, 234
- Embedding medium, an improved, 108
- EMERSON, C. P.: *Essentials of Medicine*, rev., 858
- Emetine in bilharziasis, 70, 586
- EMMS, Alfred Wilson, obituary notice of, 105
- Emotion, human, measurement of, 280
- Empire Municipal Directory of Local Authorities and Officers and Year Book of Municipal Engineering and the Sanitary Record* for 1912-22, rev., 935
- Empyema, site of operation for, 657, 719, 759, 836
- Encephalitis, epidemic, histo-pathology of (C. Da Fano), 153, (O)—Correspondence on, 210
- Encephalitis, epidemic, "minute bodies" in, 210
- Encephalitis, epidemic, myoclonic (E. J. Bradley), 891
- Encephalitis, lethargic (Wilfred Harris), 47—(G. S. Haynes), 849, (O)
- Encephalitis, lethargic (leading article), 93
- Encephalitis, lethargic, cerebro-spinal fluid in (R. Hauser Hodges), 421
- Encephalitis, lethargic, outbreak of in Great Britain, 277, 357
- Encephalitis, lethargic, and epidemic hæmorrhage, 572
- Encephalitis, lethargic, treated with influenza bacillus antigen (W. M. Crofton and D. Costello), 601
- Encephalitis, lethargic, labour in a case of (W. F. Theodora Haultain and G. O. Thornton), 382
- Encephalitis lethargica, Ministry of Health Memorandum on, 508, 662
- Encephalitis lethargica, myoclonic, case of simulating hydrophobia (Stanley E. Denyer and D. E. Morley), 191, (O)
- Encephalitis lethargica, ocular symptoms in the lighter cases of (Ransom Pickard), 851, (O)
- Encephalitis lethargica (parliamentary note), 618
- Encephalitis lethargica, past appearances of, 478, 508
- Encephalitis, lethargic, prognosis in, 172
- Endocarditis, subacute bacterial (Basill Parsons-Smith), 43, (O)
- Endocrines, review of books on, 816
- England, malaria in, 502. *See also* Malaria
- ENSOR, C. A.: Twins, 796
- Enterocolic intussusception in an adult (R. H. Kingsford), 813
- Epidemiology, the new (leading article), 432, 534—Correspondence on, 543, 581, 622, 658, 721, 796. *See also* Etiology and Evolution
- Epididymitis from muscular strain (George W. Cathcart), 193. *See also* Testicular disease
- Epilepsy considered as a symptom, not a disease (James Taylor), 4, (O)—Correspondence on, 102, 444
- Epilepsy, tuberculin in (James Crocket), 458, (O)
- ERNST, F. G.: Artificial legs, 103
- Errata. *See* Corrections
- Frysipelas, treatment of, 36
- ESCAUDA, L.: *Le forage de la Prostate, méthode de Luys*, rev., 740
- ESSER, Dr.: Emetine in bilharziasis, 70
- "Ethanesal," a new anaesthetic (R. L. Mackenzie Wallis and C. Langton Hewer), 565—Correspondence on, 622, 658
- "Ethanesal" or "ether," 622
- Ether, first use of, 611
- Ether inhaler, a compact warm, 935
- Ether vapour explosions during laryngoscopy (W. J. McCardie), 528
- ETHERIDGE, Charles E.: Appendix communicating with colon, 146
- ETIENNE: Antiquity of syphilis, 216
- Etiology, science of (leading article), 534. *See also* Epidemiology, the new, and Evolution
- Eugenics Congress. *See* Congress
- Eugenics, review of books on, 498
- European Conference on Venereal Diseases. *See* Venereal
- EVANS, Arthur: Use of alcohol in medicine, 609
- EVANS, Eric: Clause 7 of the Criminal Law Amendment Bill, 101
- EVANS, F. A.: Infectious mononucleosis, 95
- EVANS, Geoffrey: Appointed Assistant Director of Medical Unit, St. Bartholomew's Hospital, 178—Study of the arteries in a uterus removed twenty-four days after delivery, 495
- EVANS, Laming: Habitual dislocations, 383
- EVANS, Smart, presented for false vaccination certificate return, 107
- EVANS, T. Stanger: Herpes and varicella, 382
- EVATT, Major-General George J. H.: A Professor of Military Medical History at the R. A. M. College, London, 244
- EVELYN, John, and medicine, 623
- Everest expedition, 572
- Evolution, a byway of, 887
- Evolution in relation to disease, 543, 622, 721, 796. *See also* Epidemiology and Etiology
- Evolution, influence of the ductless glands on (L. Bolki), 821
- EWART, G. A.: Acute retention of urine complicated by perforation of a duodenal ulcer, 420, (O)
- Ewell Co. (now leased by Ministry of Pensions for shell-shocked patients), 202
- Excess profits duty, 692
- Exomphalos, or hernia into the umbilical cord, 263. *See also* Hernia
- Exophthalmic goitre. *See* Goitre
- Ex-service men in asylums (parliamentary note), 61, 505, 716, 952—Tuberculous (parliamentary note), 361—Antimony treatment for (parliamentary note), 476
- Eye, artificial, recoloring and recoloring of, 627—Use of, 685
- Eye, effects of carbon monoxide on, 649
- Eye injuries, economic aspect of (T. Lister Llewellyn), 118, (O)
- Eyestrain in cinematograph halls, 233, 281, 322
- F.
- Fæces in alimentary disorders (Robert Coope), 528
- FAIRBAIN, John S.: Physiological principles in midwifery practice, 413 (O)—Sterility, 816—Operative treatment of genital prolapse, 894
- FAIRBANK, H. A. T.: Orthopaedic treatment of polyomyelitis, 517, (O)
- FAIRBANK, William, C.V.O. conferred upon, 61
- FAIRLIE, H. P.: Post-anaesthetic vomiting, 194
- FALKNER, Ninian M.: Fatal poisoning from inhalation of acid fumes, 143—*Simulium reptans* in Ireland, 550
- Farmers and dangerous drugs. *See* Drugs
- FAIR, C.: Persistence of gastric ulcers after perforation, 613
- FARRANT, Rupert, obituary notice of, 177
- Fascia lata, surgical uses of (Cyril H. Cuff), 494, (O)
- Fatigue and efficiency (leading article), 131
- Fatigue Research Board, The Industrial (leading article), 203—Parliamentary note, 360, 399—Industrial fatigue and ventilation, 533. *See also* Industrial

- Fat-soluble "A" content of oils, 104
 FAULLER, T. Jefferson: Risks after operations on tonsils and adenoids in outdoor clinics, 404
 FAWCETT, Hubert A. (and A. Goff): *Macedonia: A Plea for the Primitive*, rev., 272
 FAWSITT, Thomas, dinner to, 35
 Federation of Medical and Allied Societies, election of officers, 585—Note on, 585—Annual dinner, 819
 Fee, notification, and the end of the war, 916
 Fees of Admiralty surgeons (parliamentary note), 618
 Fees of Glasgow students, 621; of Edinburgh students, 684
 Fees to medical men called by the police to be increased in Paris, 919
 Fees of public vaccinators, 171
 Femur, fracture of. *See* Fracture
 FENWICK, P. C. Collingwood: Destruction of bacilli by electricity, 812
 FERGUS, Freeland, Hon. LL.D. Glasgow conferred upon, 761
 Ferguson chemical library, 621
 FERGUSON, Haig: "Twilight sleep," 341
 FERGUSON, J. Bell: Simple goitre in school children, 444
 FERRIER, John C.: Pernicious anaemia: repeated doses of calomel; recovery, 932
 FERNIERE, Dr., elected an honorary member of the Vienna Medical Society, 627
 Fever, blackwater (L. S. Dudgeon), 94
 Fever, blackwater, use of *Vitex peduncularis* in (Lieut.-Col. J. C. S. Vaughan), 186. (O)
 Fever, brasa, 254
 Fever, cerebro-spinal, lingual application of iodine as a prophylactic in (J. A. Taylor), 776. (O)
 Fever, cerebro-spinal, studies in, 168
 Fever, enteric, in the United States, 713
 Fever, glandular, 100, 142, 509, 546, 582, 649—(H. Lethby Tidy and E. B. Morley), 452 (O)—(James Leask), 703. *See also* Lymphoblastosis
 Fever, infectious, cases in the autumn of 1920, 361
 Fever, paratyphoid, 842
 Fever, rat bite, novarsenobillon in (F. W. Burton-Fanning), 886 (O)
 Fever, scarlet, incubation period of (A. M. Watts), 495
 Fever, typhus, research hospital to be opened at Wilmo, 273—Review of books on, 857
 Fever, yellow, in Mexico, investigations on, 396—In Northern Peru, 436
 FRENCH, E. G. (and C. F. MARSHALL): *Syphilis and Venereal Diseases*, rev., 566—Treatment of venereal disease, 686
 FIELD, Captain P. C.: Order of the Nile conferred upon, 690
 Filariasis expedition to British Guiana, 280
 FILLIATRE, G. le: *Précis de Rachianesthésie générale*, rev., 741
 FINDLAY, Leonard: Congenital syphilis, 343
 Fine adjustments (leading article), 432
 Fine chemical industry. *See* Chemical
 FINELNBURG, Rudolf: *Die Therapie an den Bonner Universitätsklinik*, rev., 307
 FINZI, N. S.: X-ray radiation and cancer, 440—*Puritus ani*, 622
 First Minister of Health (leading article), 535
 Fischer's solution (incitamin), 179. *See also* Incitamin
 FISHER, Welter: Action of quinine on the pregnant and non-pregnant uterus in the tropics, 891
 Fistulae, coccygeal (J. P. Lockhart-Mummary), 807. (O)—Correspondence on, 915, 957
 Fistulae of Stenson's duct, operation for the radical cure of pre-masseretic (Gilbert Chubb), 45. (O)
 FITCH, W. E.: *New Pocket Medical Formulary*, rev., 742
 FITZGERON, Gibbon: Fibrous and muscular attachments of the vagina, 778—Primary carcinoma of vagina, 778
 FITZWILLIAMS, Duncan: Naevi in children, 605
 Flavouring agents in medicines, 27
 FLECHSIG, Paul: *Anatomie des Menschlichen Gehirns und Rückenmarks auf Myelogenetischer Grundlage*, rev., 529
 FLEMING, A. (and Captain S. R. DOUGLAS and L. COLLEBROOK): Studies in wound infections, 235
 FLEMING, Alexander: Vaccine therapy in regard to general practice, 255. (O)
 FLEMING, Robert A.: Smelling salts in prevention of sea-sickness, 726
 FLEMING, W. (and H. S. CARTER): Case of idiopathic muscular dystrophy, 609. (O)
 FLEMING, Charles E. S.: Risks after operations for tonsils and adenoids in outdoor clinics, 191
 FLETCHER, H. Morley: Congenital syphilis, 460
 FLETT, Dr.: Twilight sleep, 342
 FLINT, E. R.: The teaching of anatomy and physiology, 143—Acute intestinal obstruction, 729. (O)
 Flour, Chinese (parliamentary note), 316
 Foetus, barlequin (James T. McAuslin), 155. (O)—Correspondence on, 623
 Food Education Society, report, 180
 Food factor in pellagra (leading article), 310
 Food factors, accessory, name for, 107
 Food poisoning, outbreaks of, 170
 Food values (parliamentary note), 399
 Food in war and peace (parliamentary note), 476
 Foods, economical, pamphlet (parliamentary note), 683
 Foot muscles, action of the intrinsic and their treatment by electricity (G. Murray Leveck), 381. (O)
 FORBES, A. M. M., elected President of the Coroners' Society, 958
 FORBES, C.: Muscle re-education, 175
 Forceps, Duval's lung, modification of, 273
 FORD, R. E. (and E. T. C. MILLIGAN): Fracture of first rib, 191. (O)
 FORDYCE, Dr. (and R. W. JOHNSTONE): Haemorrhage with clampsia, 496
 Foreign body (needle) in a semilunar cartilage, 108
 FORESTIER-WALKER, C. L., appointed a Commissioner (unpaid) of the Board of Control, 447
 Forgetting, psychological, in relation to lying (Mary Bell), 123. *See also* Psychological
 FORLANINI, Carlo, memorial to, 368
 Formol-Gel reaction in syphilis (J. Mackenzie), 854
 FORT, Thomas, obituary notice of, 513
 FORTESCUE-BRICKDALE, John Matthew: *A Textbook of Pharmacology and Medical Treatment for Nurses*, rev., 817
 Death of, 868—Obituary notice of, 916
 FOSTER, W. J.: Retrograde catheterization for impermeable stricture of the urethra, 931 (O)
 FOTHERGILL, E. Rowland: The Ministry of Health and the profession, 64—Collective opinion of the profession, 362
 FOTHERGILL, W. E. (and F. H. LACEY): End-results of plastic vaginal operations for genital prolapse, 892
 FOWLER, C. Owen, appointed J.P. for borough of Croydon, 35
 FOWLER, Sir James Kingston: Artificial pneumothorax, 814
 FOWLER, Trevor Hayman: Treatment of syphilis in Macedonia, 930. (O)
 FOX, Hingston: Albuminuria and life assurance, 84
 FOX, W. S.: *Syphilis and its Treatment, with Special Reference to Syphilitis of the Skin*, rev., 231
 Fracture of femur (Major Sinclair), 229
 Fracture of femur, a simple method of extension (B. F. Pendred), 380. (O)
 Fracture of first rib (E. T. C. Milligan and R. E. Ford), 191. (O)—Correspondence on, 284
 Fractures, hospital treatment of (Robert Ollerenshaw), 559. (O)
 Fractures, influence of the war on the modern treatment of (Henry Wade), 327. (O)
 Fractures, treatment of (Major Maurice Sinclair), 229—(S. Alwyn Smith), 483. (O)
 Fractures, ununited (G. W. Beresford), 456. (O)
 Fractures of the upper extremity, treatment of (J. W. Dowden), 896
 FRAENKEL, Alexander, resigns editorship of the *Wiener klinische Wochenschrift*, 347
 France: Association pour le Développement des Relations Médicales, 325—*Bibliographie des Livres Français de Médecine et de Sciences*, 532—Latinity in, decline of, 36—Most suitable time for calling men to the colours, 157—Premium for children born in, 944—Stethoscope in, 516—Trachoma in Marseilles, 702. *See also* Paris
 FRANCIA, George Phillip, obituary notice of, 548
 FRASER, John: Limp in children, 843. (O)
 FRENCH Herbert: One or two points of medical utility, 161—Simple puncture in delayed resolution in pneumonia, 161
 FREYER, Sir Peter J.: *Clinical Lectures on Enlargement of the Prostate*, rev., 17
 FRIEL, A. R.: Vaccine therapy in regard to general practice, 320
 Friendly society support for hospitals, 712
 Frog's kidney. *See* Kidney
 Frontal sinus operation (Walter Howarth), 855
 FRY, John William, obituary notice of, 584
 FRY, Walter E.: Risks after operation on tonsils and adenoids in outdoor clinics, 174
 FRY, W. Kelsey (and H. D. GILLIES): New principle in the surgical treatment of "congenital cleft palate" and its mechanical counterpart, 335. (O)
 Fry's Royal Guide to the Principal London and other Charities, rev., 87
 FULLERTON, Andrew: Stenosis at the internal meatus after suprapubic prostatectomy, 301. (O)—Case of deformity in a child, 497—Haematuria as seen by the surgeon, 923. (O)
 FULTON, Adam, presentation to, 400
 Functional nervous disorders hospital. *See* Hospital Cassel
 Fund, King Edward's Hospital: Special meeting re voluntary hospitals, 178, 198—Annual meeting, 579—Interim report of Policy Committee, 585, 607
 Fund, Leeds Workpeople's Hospital, 871
 Fund, Nurses' National, parliamentary note, 476
 Fund, Officers' Families', report, 325
 Fund, R.A.M.C., and Officers' Benevolent Fund, annual meeting, 630
 Fund, Royal Medical Benevolent, 55, 208, 273, 476, 899, 944—Annual meeting, 611
 Fund Guild, Royal Medical Benevolent, 107, 208, 899
 Fund, Royal Medical Benevolent, Ireland: Report, 953
 Fund, Save the Children, Record, 146
 Fund, War Emergency, 28
 Funds, Auxiliary R.A.M.C., 723
 G.
 Gag, mouth, an improved, 127, 180
 GALBRAITH, S. Nicol: Tuberculous milk, 141
 GALEN (leading article), 24
 GALLOWAY, Sir James: Albuminuria and life assurance, 83—Relation of skin disease to internal disorder, 303
 Galvanic acupuncture in treatment of sciatica (E. A. Gauden), 523. (O)
 Galy in malaria. *See* Malaria treatment
 GAMAGE, A. W. and Co.: New catalogue, 841
 GAMLEN, Captain Robert Long, obituary notice of, 690
 GAMBELTOFT, Professor: Operative treatment of genital prolapse, 894
 Gangrene, review of book on, 708
 Gardening for the blind, 680, 693
 GARRATT, G. C.: Hospital staffs and paying patients 31, 70, 366—A correction, 70
 GARRISON, Fielding H.: *History of the Regimen Sanitatis*, rev., 231—(and Casey A. Wood) *A Physician's Anthology of English and American Poetry*, 277
 GARRY, T. G., reappointed British physician at Pistani, 879
 Gas-oxygen-ether outfit, improvements for use with, 19
 Gas supply, domestic, dangers of, 313
 Gastric cancer. *See* Cancer
 Gastric function, chemical estimation of (J. H. Ryffel), 383—Discussion on, 383
 Gastric ulcer. *See* Ulcer
 Gastroptosis, diagnosis and treatment of (Major John F. Hall-Edward), 698. (O)
 GATLEY, Charles A., obituary notice of, 445
 GATTRY, George, obituary notice of, 368
 GAUVAIN, Sir Haury: Non-operative treatment of surgical tuberculosis, 424
 GEDDES, George: Prevention of puerperal infection, 838
 GELIEN, J.: Diphtheria carriers, 27
 GEMMELL, J. E.: Operative treatment of genital prolapse, 894
 GEMMILL, W.: Ligation of the left subclavian artery, 739
 General Medical Council. *See* Council
 General Nursing Council. *See* Nursing
 General practice, note taking in, 430
 General practice and vaccine therapy. *See* Vaccine
 General practitioner and medical progress (Sir James Mackenzie), 797 (O)—Leading article on, 822—Correspondence on, 915
 Genital prolapse, end-results of plastic vaginal operations for (W. E. Fothergill and F. H. Lacey), 892—Discussion, 893—Leading article on, 903
 Genito urinary surgery, two instruments for, 568
 Genoa, special courses on tuberculosis at, 549
 Germany: Age-limit in the universities, 725—Institute for testing the therapeutical value of drugs, 745—Medical curriculum in, 789—Population of, 725—Secret remedies and the German medical press, 649—Students in the universities, number of, 51—Wassermann test regulations, 775—Preservation of important features of scientific research, 919
 Grant, notes on a (William Robinson), 560. (O)
 GIBB, J. A.: The risks after operations for tonsils and adenoids in outdoor clinics, 66
 GIBBES, C. Chapman, presentation to, 215
 GIBBONS, G. F. P.: Herpes and varicella, 382—Medical examination of recruits, 448
 GIBBONS, R. A.: Sterility, 815
 GIBLIN, W. E.: Tartar emetic for venereal granuloma, 932
 GIBSON, G. H. R., appointed Deputy Commissioner of General Board of Control in Scotland, 135
 GIFFIN: Splenectomy in pernicious anaemia, 470
 GILBERT, Sir Humphry, his scheme for a sixteenth century university for London, 58
 GILCHRIST, James C.: Tuberculous milk, 34
 GILCHRIST, Major Kenneth (and Major J. PRATT-JOHNSON and Captain HAY-MICHEL): Action of certain special preparations on malarial parasites and their employment in treatment of malaria, 80. (O)
 GILES, Arthur: Causes, prognosis, and treatment of sterility, 814
 GILES, A. E.: Operative treatment of genital prolapse, 893
 GILES, F. Broome: Prevention of venereal disease, 284
 GILFORD, S.: Venereal disease prevention, 246
 GILL, Lieut.-Col. C. A.: Malaria in England, 502
 GILLIES, H. D. (and W. Kelsey Fry): New principle in the surgical treatment of "congenital cleft palate" and its mechanical counterpart, 335. (O)
 GILLIEON, Thomas, Chinese Order of Chia Ho conferred upon, 208

- GIUSEPPI, P. L.: Treatment of urethral stricture, 702. (O)
- GIVEN, Surgeon-Commander D. H. C.: Some deductions from the statistics on the prevention of pulmonary tuberculosis, 225. (O)
- GLADSTONE, H. B.: Prevention of venereal disease, 174
- Gland, thymus, in everyday life (Leonard Williams), 481
- Glands, ductless, influence of on evolution (L. Bolk), 821
- Glands, review of books on, 463
- Glands, tuberculous cervical, thoracic duct wounded during removal of (G. H. Edington), 564—(Archibald Young), 564
- Glandular fever. *See* Fever.
- Glandular tuberculosis. *See* Tuberculosis Glasgow. *See* Scotland
- GLENDINING, Bryden: Surgical needles, 127
- Modified Duval's lung forceps, 273
- GLOVER, Dr.: A cancer serum, 206
- Glycosides and alkaloïds, 59
- Glycosuria (W. Langdon Brown), 345
- Glycosuria, sapraemic (Charles Gaskell Higginson), 236. (O)—(Thomas E. Mitchell), 459—(O. Layton), 459—Correspondence on, 511, 687
- GLYNN, Ernest: Pathology of influenza, 426—Mechanical apparatus for Wassermann reaction, 641, 674
- GOADBY, Sir Kenneth: Immunity and industrial disease, 827—Appointed to represent medical science on the Advisory Committee for the Metalliferous Mining Industry, 841
- Goats and goat's milk, 651
- GODFREY, T. H.: Position of arms in breech with extended legs, 366
- GODLEE, Sir Rickman J.: *Six Papers by Lord Lister*, 386—Appreciation of Peter Thomas Duncan, 583
- GOFF, A. (and Hugh A. FAWCETT): *Macedonia: A Plea for the Primitive*, rev., 272
- Goitre, exophthalmic, discussion at the Royal Society of Medicine, 268, 342, 425
- Goitre, exophthalmic, review of books on, 306
- Goitre, simple, in school children, 367, 444
- GOLDIE, Robert William, obituary notice of, 368
- Golf, Rules of*, 762
- Gonorrhoea, catheter holder for intrauterine treatment of, 569
- GOOCH, H.: Breech presentation with extended arms, 624
- GOODALL, E. W.: Relation of skin disease to internal disorder, 303
- GOODALL, J. S.: Exophthalmic goitre, 269
- GOODFELLOW, Dr.: Some aspects of preventive medicine, 642
- GOODHART, Sir James Frederic: *The Diseases of Children*, rev., 934
- GOODWIN, Lieut.-General Sir T. H. John C.: Belgian Croix de Guerre conferred upon, 253
- Gordon College. *See* College
- GORDON, Alfred: *French-English Medical Dictionary*, rev., 935
- GORDON, A. Knyvett: Instrumental abortion, 461—Differential staining of carcinomata, 687, 759—Pathology of breast epithelium, 896
- GORDON, M. H.: Serological study of haemolytic streptococci: differentiation of *Streptococcus pyogenes* from *Streptococcus scarlatinae*, 652. (O)
- GORDON, W.: Practical gains of clinical cardiology since 1900, 12 (O), 49—Gastric ulcer and gastric cancer, 99
- GORDON-WATSON, Sir Charles: Pruritus ani, 603
- GORELL, Lord: Prevention of venereal disease, 684
- GORGAS, Surgeon-General, Panama memorial to, 583, 615
- GORHAM, Patrick Charles, obituary notice of, 251
- GOULD, Sir A. Pearce: Use of alcohol in medicine, 609
- GOLDEN, E. A.: Treatment of sciatica by galvanic acupuncture, 523. (O)
- Gout, review of books on, 271
- GOVING, B. W.: Measles, intussusception, and appendicitomy in a baby seven months old, 465
- GRAHAM, F. M.: Cross of the Legion of Honour conferred upon, 584
- GRAHAM, G.: Chemical estimation of gastric function, 383
- Grandparents, great, seven alive, 370
- GRANT, James, presentation to, 919
- GRANT, Lachlan: Teapot stirrer, 36
- Granuloma, venereal, tartar emetic for (W. E. Giblin), 932
- Graves's disease. *See* Goitre, exophthalmic
- GRAY, Major George D., French Médaille des Epidémies conferred upon, 513
- GRAY, Sir Henry M. W.: Application of war lessons in civil work, 62, 109. (O)
- Great-grandparents, seven alive, 370
- GRAVES, Charles Augustus, obituary notice of, 689, 760
- GRAVES, R. B.: *Lays by the Way*, rev., 273
- Greek Lexicon*, new edition of Liddell and Scott's, 315
- GREEN, Stanley: Radium therapy, 270
- GREEN, A. Withers: Albuminuria and life assurance, 84—Cure of haemorrhoids without operation, 326
- GREENLEAF, T. Dundac: South Africa and the British Medical Association, 363
- GREENWOOD, Major (and E. J. COLLIS): *The Health of the Industrial Worker*, rev., 497—The science of etiology or the new epidemiology, 581, 658
- GREENWOOD, W. Osborne: Artificial respiration in the newborn, 601
- GREGG, D. M.: Presentation to, 62—Cardio-spasm, 705
- GREGG, Wing Commander Lewis Leister, Order of the Crown of Belgium conferred upon, 626
- GRIFFITH, J. P. Crozer: *The Diseases of Infants and Children*, rev., 531
- GRIFFITH, R. C. (and J. H. WHITE): *The Pocket Guide to Chess Openings*, rev., 465
- GRIFFITH, T. Wardrop: Three cases of heart-block, 763 (O), 956—Graphic methods in cardiac diagnosis, 813
- GRIFFITH, Walter: Operative treatment of genital prolapse, 894
- GRIFFITHS, Joseph: Voluntary hospital staffs, 98
- GRIFFITHS, L. M.: A sixteenth century scheme for a London university, 58
- Growth, inoperable, diathermy for (Sir William Milligan), 461
- GROVES, E. W. Hey: *Synopsis of Surgery*, rev., 429
- GUBB, Alfred S.: *From Cloud to Sunshine*, rev., 231—Guide to Algiers for motorists, 683
- GUFERIN: Vaccination of cattle against tuberculosis, 130
- GUBBINS, Lieut.-General Sir Lancelotte, re-appointed Special Commissioner of Royal Hospital, Chelsea, 840
- GULLAUME, A. C.: *La Sympathique et les Systèmes Associes*, rev., 196, 644—(And others): *Sympathique et glandes endocrines*, rev., 463
- GULLAN, A. Gordon: Pathology of influenza, 427
- GUNN, J. A.: Massage of the heart and resuscitation, 9. (O)
- Gunshot injury to the brain (Judson S. Bury), 556 (O)
- Gunshot wound, effect of on the skull, 628, 692
- Gunshot wounds causing bilateral hypoglossal palsy (Harold Burrows), 776
- GENTER, F. E.: Tray for tuberculin administration, 273
- GUPTA, Captain Banwari Lall, Military Cross conferred upon, 917
- GURDON, John E.: *Over and Above*, rev., 18
- GUTHRIE, C. G.: Diphtheria carriers, 27
- GUTHRIE, Douglas: Surgery of nasal deformities, 896
- GUTHRIE, R. L., appointed coroner for Eastern District of the County of London, 35
- GUYER, R. Glode: *Cultivation of Medicinal Plants in Scotland*, 960
- GUYON, Professor, eulogium delivered on at the Vienna Urological Society, 330
- Gynaecology, review of books on, 163, 816, 898

H.

- HADFIELD, J. A.: A correction, 628
- Haemarthrosis of knee, tuberculous (John A. C. Macewen), 158
- Haematemesis, post-operative, digestion of oesophagus as a cause of (Laurence T. Stewart, J. Hogarth Pringle, and J. H. Teacher), 563
- Haematoecolpos and haematometra in a child causing retention of urine (J. K. Haworth), 673
- Haematuria as seen by the surgeon (Andrew Fullerton), 923. (O)
- Haematuria, symptomless (James B. Macalpine), 631. (O)
- Haemochromatosis and bronzed diabetes (Robert Muir), 461
- Haemolytic streptococci, serological study of (M. H. Gordon), 632. (O)
- Haemorrhage, cataclysmal, after tonsillectomy, 397
- Haemorrhage with clampsia (Dr. Fordyce and R. W. Johnstone), 496
- Haemorrhage, uterine, not associated with pregnancy, treatment of (James Phillips), 224. (O)
- Haemorrhagic disease of the newborn, blood transfusion in, 791. *See also* Malaria neonatorum
- Haemorrhoids cured without operation (J. C. Lyth), 265 (O), 403—Correspondence on, 326, 364, 403, 441, 479
- Haemorrhoids treated by electrolysis (J. Curtis Webb), 457. (O)
- Hair, direction of the growth of, 867
- HALDANE, J. S.: Recent advances in the physiology of respiration, renal secretion, and circulation, 409. (O)—Fine adjustments, 432—Acidosis and alkalosis, 542
- HALE-WHITE, Sir W.: Exophthalmic goitre, 269—Richard Bright's less known contributions to medicine, 906
- HALL, Arthur J.: Herpes and varicella, 284—Relation of skin disease to internal disorder, 303—Physiology and clinical medicine in Sheffield, 688
- HALL, A. W. (and W. H. OGILVIE): Treatment of cutaneous anthrax, 889. (O)
- HALL, Donald: Herpes and varicella, 673—Artificial pneumothorax, 814
- HALL, E. Wilson: Patent ductus arteriosus, 83
- HALL, J. Basil: The voluntary principle and the Bradford bogey, 98, 212
- HALL, J. Robertson: Eight successive breech presentations in the same patient, 704
- HALLAM, Rupert: Note on his journey to the Far East re control of venereal disease, 541
- HALL-EDWARDS, Major John F.: Diagnosis and treatment of gastroptosis, 698. (O)
- HALLIBURTON, W. D.: Mackenzie Davidson lecture on the importance of the infinitely little, 449. (O)—Treatment of trypano somiasis, 777—Reviews Robert McCarris's book on deficiency disease, 896
- HALLOWES, K. R. Collis: *Oxyuris vermicularis*, 920
- HALSTED, Professor: Ligations of the left subclavian artery, 573
- HAMILTON, James: Irritable bladder, 480
- HANCE, Captain James Bennett, O.B.E. conferred upon, 958
- HANDLEY, W. Sampson: Lines of advance in the surgery of breast cancer, 37. (O)—Letter on, 320
- HANDLEY-READ, Dr.: Influence of diet on the teeth, 385
- HANRAHAN, the late Dr. J. A., an appeal, 541
- HARCOURT, Richard Eugene, obituary notice of, 839
- HARDING, M. Esther: Heart-block in diphtheria, 321—The circulation in acute infection, 462
- HARDING, R., presentation to, 325
- HARFORD, C. F.: Treatment of trypano somiasis, 777
- HARRINGTON, Sir John: His English version of *Regimen Sanitatis Salernitanum*, 231
- "Harlequin foetus." *See* Foetus
- HARMAN, N. Bishop: Eyestrain and the kinematograph, 234—Congenital syphilis, 344—Ocular palsies, 426—A direct record scotometer, 645
- The axis of astigmatism, 666. (O)—Preparation of scientific papers, 721—Organization of school ophthalmic work, 782—The private clinic system, 938
- HARRIS, E. H. R. (and Evelyn DUNDERDALE): Herpes and varicella, 600. (O)
- HARRIS, Isaac: Electro-cardiograph, 704—Heart-block and the Adams-Stokes syndrome, 791
- HARRIS, J. D.: Value of digitalis in two cases of auricular fibrillation, 49
- HARRIS, Laurence Herchell Levi, obituary notice of, 105
- HARRIS, Robert, obituary notice of, 286
- HARRIS, Wilfred: Lethargic encephalitis, 47
- HARRISON, W. J.: Diathermy in diseases of the throat and nose, 220. (O)
- Harrogate: Scientific investigations on the waters, result of, 129, 749—Baths not closing down, 661, 691
- Harrow medical officers' salary (parliamentary note), 655
- HART, T. Wheeler, appointed Deputy-Lieutenant for Lancashire, 833
- HARTILL, S.: Herpes and varicella, 284
- HARTLEY, Percival Horton-Smith: Knighthood conferred upon, 96—(and Sir E. Douglas POWELL): *On Diseases of the Lungs and Pleurae*, rev., 271
- HARVEY, Lieut.-Col. William Frederick, C.I.E. conferred upon, 61
- HARVIEY (and others): *Sympathique et glandes endocrines*, rev., 463
- HACLTAIN, F. W. N.: "Twilight sleep," 341—A correction, 408
- HAULTAIN, W. F. Theodore (and G. O. THORNTON): Labour in a case of encephalitis lethargica, 382
- HAWORTH, J. K. (and W. A. PEVERLEY): Aneurysm of external carotid artery treated by ligation of common carotid artery and internal jugular vein, 339. (O)—Retention of urine due to haematocolpos and haematometra in a child, 673
- HAWTHORNE, C. O.: Study of heart disease, 64—Preparation of scientific papers, 566, 913—The private clinic system, 939
- HAWTHORNE, J. Lorimer: Venereal disease prophylaxis, 33
- HAY, John: Prognosis in patients presenting a rapid heart action, 564—The electro-cardiograph, 704—Appointed deputy-lieutenant for Lancashire, 833
- HAY-MICHEL, Captain (and Major J. PRATT-JOHNSON and Major Kenneth GILCHRIST): Action of certain special preparations on malarial parasites and their employment in the treatment of malaria, 80. (O)
- HAYNES, G. S.: Encephalitis lethargica, 849. (O)
- Hazell's Annual and Almanack for 1921*, rev., 164
- HEAD, Henry: New study of aphasia, 863, 946
- Health Board, Central Imperial, for India, 136
- Health Minister, the first (leading article), 535
- HEALTH MINISTRY: Anthrax from shaving brushes, 207
- Appointments, 574
- Blind welfare, Advisory Committee reconstituted, 691
- Correspondence on, 31, 64, 99, 508
- Divisional and full-time health insurance officers, 61
- Draft Orders, 653

- HEALTH MINISTRY (continued):**
 Encephalitis lethargica, memorandum on 508, 662
 Estimates, 575
 Food poisoning outbreaks, 170
 Hospital Inquiry Committee, 96
 Influenza decrease, 287
 Influenza, pandemic (1918-19), report on, 205, 348, 355
 Leading article on, 56, 747
 "Lock-up" surgeries, 753
 Maternity homes and children's institutions, 97, 504
 Medical branch, 683
 Medical staff of, 475, 618, 683
 Milk regulations, 586
 Milk supply to nursing mothers, 541
 Mond, Sir Alfred, declaration of policy, 750
 Parliamentary notes, 61, 360, 475, 618, 653, 683, 750, 753, 909
 Post-graduate Education in London Committee, 178, 616, 942—Report, 942
 And the profession, 31, 64, 99
 Salaries at, 360
 Salvarsan substitutes, 178
 Sanatoriums and institutions for treatment of tuberculosis, revised list of, 959
 Scottish Board of Health, 475, 477, 507, 575, 657, 661, 953
 Tuberculosis treatment, 653
 Venereal diseases, prevention and treatment: policy of the Government, 861
 Water scarcity due to drought, 919
 Welsh Board of Health, 909
- Health Office of the League of Nations. See League**
 Health resort, one way of selecting a, 70, 146
 Health service for London, suggestions for a co-operative, 244
 Health services. State contributions to (parliamentary note), 475, 505
 Health work, international, 825
 HEARD, R. L.: Herpes and varicella, 340
 Heart, action of, and the retarded cinema, 402. *See also Cinema*
 Heart action, rapid, prognosis in (John Hay), 564
 Heart affections, graphic methods in diagnosis of (T. Wardrop Griffith), 813
 Heart-block, three cases of (T. Wardrop Griffith), 763. (O)—Correspondence on, 877, 956
 Heart-block and the Adams-Stokes syndrome, 755, 791
 Heart-block, complete, in a case of diphtheria, (R. Clayton Allen), 267. (O)—Correspondence on, 321
 Heart, dilatation of (D. W. Samways), 188. (O)
 Heart disease (W. Gordon), 12, 49—Discussion on, 49
 Heart disease, pensions grant for (parliamentary note), 576
 Heart disease, study of, 64, 143
 Heart, disordered action of "D. A. H." (G. L. Thornton), 49
 Heart failure, dextrose in (G. Scott MacGregor), 158—Correspondence on, 248
 Heart irregularity, relation of temperature to (R. Macnair Wilson), 226. (O)
 Heart massage and resuscitation (J. A. Gunn), 9 (O)—(Robert B. Coleman), 47—(Norman M. Dott), 192—(C. Langton Hewer), 228. *See also Resuscitation*
 Heart, review of books on, 498, 816
 Heart. *See also* Auricular, Cardiac, Cardiology, and Mitral
 HEATH, Charles J., elected a Companion of the Institute of Marine Engineers, 253
 HEHR, Major General Sir Patrick: Appreciation of Captain E. R. Armstrong, 481
 Hemicolectomy, 213
 HENDERSON, I. F. (and W. D. HENDERSON): *A Dictionary of Scientific Terms*, rev., 51
 HENDRIE, A. S.: Herpes and varicella, 726
 HENDRY, Dr.: Twilight sleep, 342—Caesarean section, 605—Amenorrhoea followed by severe trauma, 779
 HENRY, A. Kirkpatrick, Cross of the Legion of Honour conferred upon, 584
 HENSCHEN, Salomon Eberhard: *Klinische und Anatomische Beiträge zur Pathologie des Gehirns*, rev., 706
 HENSON, W. J.: An acid dentifrice, 408
 Herbalist sentenced for performing an illegal operation, 407
 Herbs medicinal, 60
 Heredity, review of books on, 464
 Hermaproditism, 692. *See also Sex*
 HERNAMAN-JOHNSON, F.: Exophthalmic goitre, 342—Immunizing effect of α rays in cancer, 365, 510
 Hernia, diaphragmatic, 880
 Hernia, femoral, radical cure of by the inguinal route (G. P. Newbolt), 15
 Hernia, large scrotal, obstruction by a hand in (Philip Turner), 738 (O)
 Hernia into umbilical cord (Robert Tennent), 263. (O)
 Herpes and varicella (A. E. Carver), 227. (O)—(E. L. Elliott), 302—(Fred. Tresilian), 340—(R. L. Heard), 340—(W. Oifford Nash), 340—(G. Young Eales), 340—(Gordon McDougall), 340—(J. P. Martin), 340—(G. F. P. Gibbons), 382—(T. Stenner Evans), 382—(E. H. R. Harries and Evelyn Dunderdale), 600. (O)—(Donald Hall), 673—(George E. Elkington), 891—Correspondence on, 284, 448, 726, 762, 842
 Herpes zoster and varicella, association of (W. Morton Robson), 228
 Herpes zoster and varicella, concurrent (Rowland Hill), 302
 HERRING, Herbert T.: Chronic retention of urine arising from prostatic disorder, 376 (O), 554
 HERZFELD, Gertrude M. A., awarded a Gibson research scholarship, 918
 HESS, Alfred F.: *Scurvy, Past and Present*, rev., 85
 HEWAT, Colonel Sir John, Belgian Ordre de la Couronne conferred upon, 515
 HEWER, C. Langton: Massage of heart and resuscitation, 228—A disclaimer, 550—A new anaesthetic "ethanesal," 565, 659
 HEWETT, Frederick Stanley, K.C.V.O. conferred upon, 58, 61
 HEWITT, Lieut.-Col. Edmund Philip, Belgian Order of Leopold conferred upon, 252
 HEWITT, Dr.: Caesarean section, 604
 HEWKLEY, Frank, awarded the Order of Mercy, 35
 HEWLETT, R. Tanner: *The Principles of Preventive Medicine*, rev., 346—*A Manual of Bacteriology*, rev., 857
 HEYWOOD, G. C. (and others): Residual vaccines, 846. (O)
 Hiccough, epidemic, 28; and encephalitis lethargica, 572
 Hiccough, spasmodic (Urquhart Bartholomew), 82
 HIGGINSON, Charles Gaskell: Sapræmic glycouria, 296 (O), 687
 HIGHAM, J. Parkinson: Refraction work among school children, 793
 Highlands and Islands Medical Service, 30
 HIGHMAN, W. J.: *Dermatology*, rev., 676
 HILL, A. V.: Physical science and the living organism, 743
 HILL, C. A.: The fine chemical industry, 133
 HILL, Edward (of Dublin), note on, 95
 HILL, Leonard: Pressure in the renal, portal, and frogular capillaries of the frog's kidney, 526 (O)—(and J. A. C. CAMPBELL): Physiological cost of muscular work, 733 (O)—Capillary pressure and oedema, 767 (O), 954
 HILL, Sir Robert: Influenza in the Navy, 705
 HILL, Rowland: Concurrent herpes zoster and varicella, 302
 HILTON, O.: Herpes and varicella, 760
 HIMMELSTRUP, E.: "Incitamin," 288
 HINGLEY, Lieut.-Col. S. H.: *Hints on Royal Auction Brides*, rev., 465
 HINGSTON, Charles Albert, obituary notice of, 584
 HIPWELL, A.: Cardiac conditions in cases attending a tropical disease clinic, 49
 HIRSCH, Charles T. W.: Ethanausal anaesthesia, 659
 HIRSCH, I. Seth: *Principles and Practice of Roentgenological Technique*, rev., 126
 HIRST, John Cooke: *A Manual of Gynecology*, rev., 87
 Hispano-Portuguese Association for Advancement of Science, 350
 History of medicine. *See* Medical history
 History of Medicine Congress. *See* Congress and Medical history
 HOARE, E. P., called to the Bar, 918
 HOBBS, Remington: Catheter holder for intra-uterine treatment of gonorrhoea, 569
 HOBDAY, Professor: Some of the diseases of animals communicable to man, 351—Eradication of tuberculosis, 423
 HODGES, R. Hamer: The cerebro-spinal fluid in encephalitis lethargica, 421
 Hodgkin's disease, leucocytic changes in (Professor Stewart), 813
 HODGSON, William, knighthood conferred upon, 58, 61
 HOGG, F. S. D.: Treatment of alcoholism, 750
 Holland, rabies in, 482, 784
 HOLLAND, C. Thurstan: The hour-glass stomach, 6. (O)—Some of the rarer conditions of bones, 270—Appointed Deputy Lieutenant for Lancashire, 833
 HOLLINGWORTH, H. L.: *The Psychology of Functional Neuroses*, rev., 780
 HOLLIS, Harry, obituary notice of, 513
 HOLLOWAY, Guy W. E.: Alkaline dentifrices and the decrease of dental caries, 726
 Holloway prison (parliamentary note), 951
 HOLME, E. R.: *The American University: an Australian View*, 864
 HOLMES, Gordon: Ocular palsies, 426
 HOME, W. E.: "Change of air," 443
 Home service ambulances. *See* Ambulances
 HONEY, Thomas Edward, obituary notice of, 725
- HONOURS:**
 Order of the Bath:
 K.C.B., 61, 865
 C.B., 865
 Order of the Star of India:
 C.S.I., 917
 Order of St. Michael and St. George:
 O.M.G., 61
 Order of the Indian Empire:
 K.C.I.E., 865
 C.I.E., 61, 865, 917
 Royal Victorian Order:
 G.C.V.O., 725
 K.C.V.O., 61
 C.V.O., 61
 HONOURS (continued):
 Order of the British Empire:
 C.B.E., 34
 O.B.E., 34, 144, 917, 958
 M.B.E., 144
 Knighthood, 61, 96, 652, 865, 959
 Military Cross and Bars, 917
 Birthday, 865
 New Year, 58, 61
 Kaiser-i-Hind Medal, 61, 865
 Order of St. John of Jerusalem, 215, 253
 Order of Mercy, 35
 Territorial Decoration, 69, 548
 Foreign decorations, 208, 215, 253, 446, 515, 584, 626, 690, 795
 Mentioned in dispatches, 144, 178
 Mention for Distinguished Service, 215, 917
 Promotions, 61, 917
 HOOD, Alexander Jarvie, knighthood conferred upon, 58, 61
 HOOVER, Mr., elected honorary member of the Vienna Medical Society, 627
 HOPKINS, L. Gordon: Position of the arms in breech with extended legs, 444
 HOPKINS, Frederick Gowland: Vitamins, 237—Appointed to the Sir William Dunn chair of biochemistry at University of Cambridge, 616
 HOPKINS, J. G. (and others): *Typhus Fever, with Particular Reference to the Serbian Epidemic*, rev., 857
 HOPSON, Montague, appointed examiner for Royal Naval Dental Service, 879
 HOPTON, Ralph: Refraction work in children, 914
 HORDER, Sir Thomas: Stasis and the prevention of cancer, 31—The private clinic system, 937
 HERRIDGE, Mr. Justice, and professional secrecy, 904
 Horse serum in treatment of angio-neurotic oedema, 68
 HORSLEY, Sir Victor, memorial to, 19, 281, 683—Names of committee, 19
 HOSKIN, Jenner: Five hundred cases of malaria in pensioners, 493. (O)—Amoebic dysentery complicating malignant disease of lower bowel, 563
 Hospital, 14th General, reunion dinner, 481
 Hospital, 29th General, reunion dinner, 35
 Hospital accommodation for disabled men, (parliamentary note), 909
 Hospital, Addenbroke's, Cambridge, appointments, 761
 Hospital Almoners Council, report, 574
 Hospital, Belfast Royal Victoria, resignations, 872—Appointments, 953
 Hospital, Belleouston, Glasgow (parliamentary note), 618, 716, 869, 909—Committee of inquiry appointed, 840, 872
 Hospital, Bradford Municipal General, 171—Parliamentary note on, 540. *See also* Hospitals, voluntary
 Hospital, Bristol General, paying patients at, 832
 Hospital, British Ophthalmic, Jerusalem, report, 628
 Hospital, Cassel (for functional nervous disorders), foundation of, 630
 Hospital, Edinburgh Royal, for Sick Children, report, 790
 Hospital, Edinburgh Women's, and Hospice, annual meeting, 719
 Hospital finance: Evidence of Mr. Gilbert P. Panter, 287—Parliamentary note, 753—Meeting of committee, 789 *See also* Hospitals, voluntary
 Hospital for functional nervous disorders, 680. *See also* Hospital, Cassel
 Hospital, Glasgow Cancer, report, 507
 Hospital, Glasgow Ear, Nose and Throat, annual meeting, 912
 Hospital, Glasgow Maternity, serious position of, 362
 Hospital, Great Northern Central: Amalgamation scheme, 135, 253—Grades its accommodation, 287—Suggestions regarding payment for insured persons, 579. *See also* Hospital, Royal Chest
 Hospital, Great Ormond Street, for Children: Dinner of staffs, next and following, 879
 Hospital, Guy's: *Reports*, vol. lxxix, rev., 934
 Hospital Inquiry Committee, 96, 135, 170
 Hospital, Irish, wounded in, 477. *See also* Hospitals, Dublin
 Hospital, Liverpool Children's, report, 621
 Hospital, London: Little triennial prize, 176—Schorstein lecturers, 208—The closing of wards (parliamentary note), 909
 Hospital maintenance (Australia), 684
 Hospital, maternity, with its ante-natal and neo-natal departments (J. W. Ballantyne), 221. (O)
 Hospital, Maudsley, lectures at, 325
 Hospital, Middlesex, medical research exhibit at Olympia, 254—Appointments, 879
 Hospital, Middlesex, at Clacton-on-Sea during the Great War, 1914-1919, *Annals of*, rev., 934
 Hospital, Naval, at Yokohama (parliamentary note), 476, 576
 Hospital patients, psychology of (W. Calwell), 497, 736, 793 *See also* Psychology
 Hospital, Princess Louise Cottage, Erskine (for limbless men), report, 242
 Hospital problems (leading article), 24—(Stanley Raw), 127. *See also* Hospitals, voluntary

- Hospital, Royal Chest, scheme to improve, 96
—To merge with Great Northern Central Hospital, 135, 253. See also Hospital, Great Northern
- Hospital, Royal Edinburgh Mental, report, 394, 400
- Hospital, Royal Free (London School of Medicine for Women): Extension, 22—"At home," 407—Obstetrical unit at, 714
- Hospital, St. Antoine, Paris: Special course on digestive diseases, 959
- Hospital, St. Bartholomew's: Result of peace commemoration appeal, 215—Foundation of new nurses' home laid by the Queen, 325
- Hospital, St. George's, to remain on its present site, 368
- Hospital, St. Luke's, Bradford, 287
- Hospital ship built at Philadelphia, 919
- Hospital ships, sinking of (parliamentary note), 361
- Hospital, Sir Patrick Dun's, roll of honour, 834
- Hospital staffs and paying patients: Correspondence on, 31, 66, 70, 98, 366—Leading article, 310. See also Hospitals, voluntary, and SUPPLEMENT Index
- Hospital, Sydney, report, 684
- Hospital, typhus research, to be opened at Wilmo, 273
- Hospital, University College, Ladies' Association, note on, 841
- Hospital, Warneford, report, 400
- Hospital, Wellhouse, Barnet (parliamentary note), 438
- Hospital, West Middlesex (Isleworth), note on, 952
- Hospital, Willesden, and municipal clinics, 171
- Hospitals and approved societies (parliamentary note), 576
- Hospitals, Dublin, wounded persons in, 209, 319, 477
- Hospitals, Dublin Associated, fête, 439
- Hospitals, friendly society support for, 712
- Hospitals and income tax, 681
- Hospitals, Voluntary, Committee, 956
- Hospitals, voluntary, conference on, 31, 66, 70, 98, 137, 366—And the Bradford bazaar, 98, 137, 171, 212, 245, 287, 540—(Stanley Rawl), 127—Sussex provident scheme, 129, 132—Special meeting of Council of King Edward's Hospital Fund, 178, 198—The voluntary system in London, 198, 607—Meeting of Lord Cave's committee, 208—Interim Report of Committee, 468, 474, 607—Report of Committee, 870, 899—Parliamentary notes, 474—Leading article on, 902. See also Hospital staffs and Hospital finance
- Hôtel-Dieu, memorial to internes of Paris hospitals who died on active service erected at, 739—Post-graduate courses, 795
- Houghton, J. E.: Acute benign lymphoblastosis, 649
- Hour-glass stomach. See Stomach
- Housing and town planning conferences, 959
- Housing Bill, 399
- Housing of miners, 539
- Housing in Scotland, 580
- Hovell, Mark: Indications for and against complete tonsillectomy, 855—Enucleation of the tonsils, 916
- Howard, Robert J. Bliss, obituary notice of, 105
- Howard, William Travis: Pre-natal death, 786
- Howarth, Walter: Frontal sinus operation, 855
- Howarth, W. J.: elected President of the Society of Medical Officers of Health, 795
- Howat, R. Douglas: Prevention of puerperal infection, 837
- Howitt, John R.: Needle in a semilunar cartilage, 108
- Hoysted, Colonel Isaac, obituary notice of, 760
- Hoxten, W. J.: The drooping shoulder sign of phthisis, 248
- Hudson, Lieut.-Col. Corrie, C.I.E. conferred upon, 917
- Hudson, T. A. G.: Early diagnosis of phthisis, 216
- Hughes, Captain Clement A.: French Médaille des Epidémies conferred upon, 515
- Hughes, C. Alston: Refraction work in school children, 876
- Hughes, Colonel David Erskine, obituary notice of, 406
- Hunt, Captain William, O.B.E. conferred upon, 958
- Hunter, James, obituary notice of, 324
- Hunter, Walter: Treatment of gastric and duodenal ulcers, 122
- Hunter, Colonel William, dinner to, 787—The coming of age of crab sepsis, 859
- Hurry, Jamieson B.: *The Octocentenary of Reading Abbey, 1121-1921*, rev., 899
- Hurst, A. F.: *The Psychology of the Special Senses*, rev., 162—The private clinic system, 939
- Hustans, H. Wessen: Triplets, 70
- Huston, J.: Fate of the lymphocytes, 905
- Hutchison, Robert: Diagnostic significance of abdominal pain in childhood, 1 (O)
- Hydrocephalus in achondroplasia, 435
- Hydrocephalus, double congenital (R. W. Johnstone and F. J. Browne), 160
- Hydrophobia simulated by myoclonic encephalitis lethargica (Stanley E. Denyer and D. E. Morley), 191. (O)
- Hydrophobia Prevention Society, annual meeting, 295
- Hygiene, review of books on, 50
- Hygiene of seamen, 538, 842
- Hyperidrosis, 216
- Hyperkeratosis congenitalis (J. T. McAuslin), 155 (O). See also Foetus
- Hypertonic salines. See Salines
- Hypnotism, review of book on, 567
- Hypoglossal palsy. See Palsy
- Hysteria, review of books on, 464
- I.
- Iliac fossa, right, surgery of (J. E. Adams), 674
- ILIFFE, Charles Webb, obituary notice of, 548
- Illegitimate infant mortality. See Mortality
- Immunity and anaphylaxis (H. H. Dale), 820
- Immunity and industrial disease (Sir Kenneth Goadby), 827
- Incitamin of Fischer's solution, 179, 288
- Income tax, 36, 69, 89, 145, 179, 216, 254, 288, 316, 326, 369, 407, 447, 482, 516, 549, 585, 628, 662, 692, 725, 762, 796, 841, 880, 920, 951, 959—Assessment, 951—Information re the new income tax, 89—Parliamentary notes, 316, 951—And hospitals, 681—Excess profits duty, 692
- Index Medicus, new series, 614
- Indexes, the half-yearly, 146
- INDIA:
- Calcutta School of Tropical Medicine, 97
- Central Board of Health, 136
- Civil assistant surgeons, 755
- Dangerous drugs in (parliamentary note), 438
- Dental school in Bombay, 136
- Medical colleges in Bengal, 97
- Medical officers' pay in (parliamentary note), 618
- Opium supply to Hong Kong, 438, 505
- Rabies in, 36
- Subassistant surgeons 136
- Tata professorships, 35
- Veneral diseases treatment, 755
- Indian Army Officers' pensions (parliamentary note), 909
- Indian Medical Service: Parliamentary notes on, 360, 475, 683, 715, 909—New rates of pay for R.A.M.C. officers in, 406—Travelling facilities, 475—Civil employment pay, 625—Appeals, 683—Army officers' pensions, 909—Annual dinner in London, 957
- Industrial disease and immunity (Sir Kenneth Goadby), 827
- Industrial Fatigue Research Board (leading article), 203—Parliamentary notes, 360, 399—Industrial fatigue and ventilation, 533. See also Fatigue
- Industrial hygiene, advisory committee of experts to be approved by International Labour Office, 959
- Industrial unrest (C. M. Wilson), 825
- Industrial welfare and research, conference at the Mansion House, 435—Review of books on, 497
- Industrial Welfare Society, note on, 627
- Industry, problems of, 748
- Infant diseases due to prolonged feeding with excess of carbohydrates (C. E. Bloch), 293. (O)
- Infant mortality. See Mortality
- Infant Welfare Congress, 23. See also Maternity and child welfare
- Infantile paralysis. See Poliomyelitis
- Infectious fever. See Fever
- Infinitely little, importance of the (W. D. Halliburton), 449. (O)
- Infirmaries, Poor Law, future of, discussion at Harveian Society, 200
- Infirmary, Bristol Royal, paying patients at, 832
- Infirmary, Dundee Royal, appointments, 401
- Infirmary, Edinburgh Royal: Report, 62—Comparison of figures 1881-1920, 242—Gynaecology at, 580
- Infirmary, Glasgow Royal, report, 282
- Infirmary, Leeds General: Changes in the honorary staff, 754—Death of Mr. Edward Ward, 754—Statistics, 754—School of nursing at, 832—Re-allocation of beds, 912
- Infirmary, Leicester Royal: The Male Venereal Clinic at (Major Henry J. Blakesley), 619—Report, 621
- Infirmary, a Liverpool Poor Law (Mill Road), paying patients at, 209
- Infirmary, Liverpool Royal, appointments, 755
- Infirmary, Manchester Royal: Report, 242—Finance, 242—Research in radio-therapeutics, 787
- Influenza: In Western Australia, 63—Decrease in number of cases in February, 287
- Influenza bacillus antigen in treatment of encephalitis lethargica (W. M. Crofton and D. Costello), 601
- Influenza epidemic in the Navy (Surgeon Commander S. F. Dudley), 705
- Influenza, lingual application of iodine as a prophylactic in (J. A. Taylor), 776. (O)
- Influenza and measles, pneumonic complications of (leading article), 710
- Influenza, pandemic, 1918-19, Ministry of Health's report, 205, 348—Leading article on, 355
- Influenza, pathology of (J. G. Adams), 48; discussion on, 48, 426
- Influenza, relation of pneumococci and streptococci to (W. R. Logan), 189. (O)
- Influenzal infection, experimental (F. G. Blake and R. L. Cecil), 94
- INGRAM, Captain William J. S., Bar to Military Cross, 917
- Injuries, self-inflicted, in civilian practice (A. Rendle Short and Cyril H. Walker), 298. (O)
- INMAN, A. C.: Eradication of tuberculosis, 423
- Inoperable growths. See Growths
- Insanity, definition of, 104
- Insanity, review of books on, 644
- Insect vectors of disease, 369
- Instinct, review of book on, 305
- Institute of Physics, 679
- Institution, Liverpool Medical: Pathology of influenza, 48, 426—Left-handedness 123—Tumour of the parotid gland, 270—Some of the rarer conditions of bones, 270—Surgical practice in China and recent developments in medical education, 270—Diathermy of inoperable growths, 461—Fæces in alimentary disorders, 528—Indications for blood transfusion, 564—Prognosis in patients presenting a rapid heart action, 564—The blood group in mother and child, 641—Mechanical apparatus for use in the Wassermann reaction, 641—674—Antiquity of syphilis, 704—The electro-cardiograph, 704—Uses and limitations of the cystoscope, 705—Cyst of the brain in a youth of seventeen, 705—Memorial tablet to members who gave their lives in the war, 717, 755—Special meeting: three jubilees, 911
- Insurance Committees, medical chairmen of, 288
- Insurance Committees, National Association of: Appreciation of the Right Hon. C. Addison, 661
- Insurance, life. See Life
- INSURANCE, NATIONAL:
- Administration, 869
- Contributions, 360
- Discharged soldiers and insurance benefit, 909
- Divisional and full time health insurance officers, 61
- Estimates (for Ireland), 575
- Flavouring agents in medicine, 27
- Highlands and Islands Medical Service, 30
- Insurance Committees and medical record cards, 438
- Insurance doctors' duties, 360
- Insurance practitioner's refusal to disclose, 869
- Medical benefit, 653, 951
- Medical record cards, 59, 145, 199, 316, 360, 399, 438, 475—Protest by National Medical Union, 145—As evidence, 199—And Insurance Committees, 438
- Medicines for panel patients, 29
- Parliamentary notes, 29, 61, 316, 360, 399, 438, 475, 653, 716, 869, 908, 951
- Payment for insured persons, opinion of Great Northern Hospital, 579
- Record cards. See Medical
- Refusal to disclose, 869
- Rules for sickness and disablement benefit, 909
- Saatorium benefit transfer (England), 96, 678; (Scotland), 96, 135—Termination of, 438
- Tuberculosis treatment, 438, 539
- Unemployment and sickness benefit, 716, 951
- Intelligence test, 36
- Internal organization and public health (G. S. Buchanan), 331. (O). See also Public health
- Intestinal cancer. See Cancer
- Intestinal obstruction, acute (E. R. Fliuth), 729. (O)
- Intestinal obstruction by a band in a large acrotal hernia (Philip Turner), 738. (O)
- Intestinal obstruction after ventrofixation, prevention of (Alexander Don), 563—R. Steward, 639
- Intestinal protozoa endemic in Britain (leading article), 276 Correspondence on, 363
- Intestinal stasis, results of colectomy for (A. W. Sheen), 116. (O). See also Hemicolectomy
- Intrapericardial pressure, manometer for, 465
- Intussusception, acute, resection of intestine for (A. H. Southam and C. H. Crawshaw), 266. (O)
- Intussusception, entero-colic, in an adult (B. H. Kugstord), 815
- Io-line, lingual application of as a prophylactic in cerebro spinal meningitis and influenza (J. A. Taylor), 776. (O)
- Ireland:
- Acidæmia, 319
- Arrests of medical men, 319
- Auxiliary Division in, medical needs of (parliamentary note), 654
- Belfast, visit of Sir George Makins, 209
- Bigger, Sir Edward Coey, 62
- Campbell, Robert, memorial, 98
- Central Midwives Board, 362
- Dangerous Drugs Regulations, 950
- Dublin: Wounded persons in the hospitals, 209, 319—King's Professor of Materia Medica, 243—Associated hospitals, 439
- Hanrahan, the late Dr. J. A., an appeal, 541
- Insurance, National, estimates, 575

Ireland (continued):

- Irish Medical Association, 953
 Irish Public Health Council, 62
 King's Professor of Materia Medica, 243
 McWalter, J. C., sudden death of, 242
 Medical reform in Ireland (R. J. Rowlette), 344
 Moore, Henry, memorial to, 62
 National University of Ireland, 657
 Parliament, elections to Senate, 907
 Poor Law medical officers and local government returns, 656
 Poor Law medical officers' salaries, 477
 Queen's University, representation of in the Ulster Parliament, 242
 Royal Medical Benevolent Fund Society, 953
 Royal Victoria Hospital, Belfast, 872, 953
Sinuidium reptans, in, 550
 Sinton, Major J. A., honour to, 30
 Sir Patrick Dun's Hospital roll of honour, 834
 Ulster Medical Society, 30, 209, 319, 834
 Ulster Parliament, the new, 656, 834—
 Medical members of, 834
 Wounded in hospital, 477

- Irish Medical Association. See Association
 Irish Medical Schools' and Graduates' Association. See Association
 Irish public health, 62
 Iron workers, catarract in, 905
 IRVING, H. B. (editor): *Trial of the Wainwrights*, rev., 272
 IRWIN, S. T.: Surgery of bones and joints, 497
 IRWIN, W. K.: Appendix clamp, 568
 Isle of Rhodes, large hospital to be erected on, 717
 Islington's medical officer, superannuation of (parliamentary note), 618
 Italy: Congress of the Society of the History of Medical and Natural Sciences, 253—Institute of medical bibliography established at Naples, 347—Cuzzolino collection of anatomical and pathological specimens presented to the oto-rhino-laryngological clinic of Naples, 387—Post-graduate course at Naples, 549—Small surgical hospital opened at Aleppo, 562—Sanitary Industries Congress, 583
 Itching. See Pruritus
 IVENS, Frances: The use of antigonoococcal serum, 77. (O)

J.

- JACK, W. R.: Treatment of gastric and duodenal ulcers, 123—*Wheeler's Handbook of Medicine*, rev., 164
 JACKSON, Arthur, obituary notice of, 177, 210
 JACKSON, J. Deputy Surgeon-General Sir Robert William, obituary notice of, 760
 JAMESON, H. Lyster: Pearl pathology, 827
 JAMESON, W. Wilson: *Hygiene*, rev., 50
 JANSEN, Murk: *On Bone Formation: its Relation to Tension and Pressure*, rev., 565
 Japan: Principal *Shins* leaving Tokio to carry a medical officer, 76
 Japan Medical World, foundation of, 646
 JARDINE, ROBERT: *A Practical Textbook of Midwifery for Nurses*, rev., 18—Alteration of presentations and positions in labour, 603
 JARRATT, A. Kaye: *Amazia (strabismic)*, 369
 JAVA, plague in, 210, 267, 661
 JEANBRAUD, E. (and others): *Chirurgie Réparatrice et Orthopédique*, rev., 16
 JEANS, Frank: Uses and limitations of the cystoscope, 705
 JEFFREY, John, presentation to, 549
 JELLET, Henry: *A Short Practice of Midwifery*, rev., 18
 JENKINS, C. E. (and others): Residual vaccines, 846. (O)
 JENNER, Edward: 125th anniversary of the first vaccination, 840
 JENSEN, E. T.: Committee for the Prevention of Tropical Diseases, 512—Treatment of trypanosomiasis, 777
 Jerusalem: British Ophthalmic Hospital, report, 628
 JEWESBURY, R. C.: Congenital syphilis, 460
 JEX-BLAKE, A. J.: *Physical Signs in the Chest and Abdomen*, rev., 229
 Johns Hopkins Hospital Reports, vol. xxi, fasc. ii, rev., 818
 Johns Hopkins Medical School and Johns Hopkins Hospital: Unusual situation brought about by the resignation of William S. Thayer, 841
 Johns Hopkins University to send an expedition to Porto Rico to study malaria, etc., 919
 JOHNSON, Roswell Hill (and Paul POPENHOE): *Applied Eugenics*, rev., 498
 JOHNSTON, Arnold, memorial to, 656
 JOHNSTONE, R. W. (and F. J. BROWNE): Double congenital hydronephrosis, 160—Twilight sleep, 342—(and Dr. FORDYCE): Haemorrhage with eclampsia, 496
 Joints and bones, surgery of (S. T. Irwin), 497
 JOLL, C. A.: Exophthalmic goitre, 425
 JONES, Ernest: *Treatment of Neuroses*, 816
 JONES, F. Carlton (and H. C. WOODHOUSE): Bradycardia, 527
 JONES, H. E.: Treatment of gastric and duodenal ulcers, 123
 JONES, Sir Robert: Cameron lecture on the necessity of orthopaedic training, 181. (O)—

- Presentation to, 241—(Editor): *Orthopaedic Surgery of Injuries*, rev., 642—Appointed Deputy-Lieutenant for Lancashire, 833
 JONES, Robert David, obituary notice of, 251
 JONES, T. Henry, presentation to, 515
 JORDAN, A. R.: Prevention of puerperal infection, 757
 JORDAN, Furneaux: Operative treatment of genital prolapse, 894
 JOSHI, Captain Nitya Nand, O.B.E. conferred upon, 917
Journal of Laryngology and Otolaryngology, 207
Journal of Obstetrics and Gynaecology of the British Empire, 713
Journal of Comparative Psychology, vol. i, No. 1, rev., 818
 JULER, Henry Edward, death of, 652—Obituary notice of, 688
 JULIAN, F. B.: Salvarsan and the Wassermann test, 582
 Juries, women on, 134

K.

- Kaolin in the treatment of cholera (R. R. Walker), 640
 Kasan: Soviet Tartar Republic forms a medical institute with special section for hygiene of labour, 761
 Kashmir, medical missionary work in, report, 714
 Keats centenary, 360, 905
 KEEN, W. W.: Eighty-fourth birthday of and dinner to, 35, 279
 KEITH, Arthur, knighthood conferred upon, 865—Reviews John M. Tyler's book on *The New Stone Age in Northern Europe*, 933
 KELLOE, T. H.: Non-operative treatment of surgical tuberculosis, 425
 KELLY, Howard A. (and Walter A. BURRAGE): *American Medical Biographies*, rev., 306
 KENNAWAY, E. L. (and Henry MACCORMAC): Treatment of syphilis, 415. (O)
 KENNON, Robert: Tumours of the parotid gland, 270
 KENNY, John Drought, obituary notice of, 513
 KENWOOD, Henry R.: *Public Health Laboratory Work (Chemistry)*, rev., 50
 Keratoderma blennorrhagica (David Lees), 896
 KERR, J. M. Munro: Caesarean section, 604—Resection of double uterus followed by two full-time pregnancies, 779
 Key industries, chemicals among (parliamentary note), 753
 KEY, M. Aston: Need for post-graduate instruction in mouth sepsis, 920
 Kharsivan in malaria. See Malaria treatment
 KIDD, Fleet Surgeon Anthony, obituary notice of, 840
 KIDD, Frank: Renal decapsulation for chronic parenchymatous nephritis, 378. (O)
 KIDD, H. Cameron: Site of operation for empyema, 657—The preparation of scientific papers, 793
 KIDD, Leonard J.: Adrenaline in resuscitation, 137—Post-herpetic itching, 725
 KIDD, Walter: *Initiative in Evolution*, 867
 Kidney of the frog, pressure in the renal, portal, and glomerular capillaries of (Leocard Hill), 526. (O)
 Kidneys, function of in prostatic enlargement (J. F. Dobson), 289. (O)
 KIMMINS, C. W.: *Children's Dreams*, 906
 Kinematograph, the, and eye-strain, 233, 281, 322. See also Cinema
 Kinematography, artificial lighting for (J. C. Elvy), 234
 King Edward's Hospital Fund. See Fund
 KING, Norman C.: Medical registration, 583
 King's Professor of Materia Medica (Ireland), 243
 KINGSCOTE, Ernest: Dilated pupils, 216—Predisposing causes of consumption, 370
 KINGFORD, B. H.: Enterocolic intussusception in an adult, 813
 KINI, Lieut. Mangalore Gopal, Military Cross conferred upon, 917
 KIRWAN, Lieut.-Col. Albert, obituary notice of, 690
 KLEMPERER, G.: The medical curriculum in Germany, 789
 KLIGLER, L. J.: Investigations into yellow fever in Mexico, 396; in Northern Peru, 436
 KNAGGS, Samuel Thomas, obituary notice of, 877
 Knee injury causes a mysterious pain, 880
 Knee, tuberculous haemarthrosis of (John A. C. Macewen), 158
 Knee-cap, an improved, 164
 Knee-joint, treatment of acute pyogenic infection of (A. H. Southam), 884. (O)
 KNIGHT, A. E., to hold the combined post of Regional Director and Commissioner of Medical Services in the Ulster Region of the Ministry of Pensions, 625
 KNOX, Alice Vance: *General Practice and X Rays*, rev., 346
 KNOX, E.: Treatment by *rays* and radium, 304
 KRAEMER, Henry: *Scientific and Applied Pharmacognosy*, rev., 386
 KRAEPELIN, Emil: *Manic-Depressive Insanity and Paranoia*, rev., 644
 KRUMBHAR, Edward B.: Electrocardiograph in heart disease, 306
 KYFFIN, Lieut.-Col. John, Belgian Ordre de Leopold conferred upon, 515

L.

- LABRÉ, Marcel: *Le Diabète Sucré*, rev., 858
 LABORDE, BECLERE, and COTTENOT: *Radiologie et Radiumthérapie*, rev., 676
 Labour Bureau, International: Figures as to disabled service men, 919—Industrial hygiene experts' advisory committee, 959
 Labour, alteration of presentation and positions in (Robert Jardine), 603
 Labour: Delivery of child and placenta in unruptured membranes at term, 108
 Labour: Eight successive breech presentations in the same patient (J. Robertson Hall), 704
 Labour in a case of encephalitis lethargica (W. F. Theodore Haultain and G. O. Thornton), 382
 Labour, morphine in (Louise McIlroy), 159
 Labour: Normal delivery after traumatic rupture of uterus (R. Thorne Thorne), 459
 Labour: Position of the arms in breech with extended legs, 320, 366, 444, 624
 Labour, scopolamine-morphine in (F. W. N. Haultain), 341—A correction, 408. See also Twilight sleep
 Labour, teaching of the mechanism of (Lieut.-Col. A. Buchanan), 238
 Labour, transverse cervical laceration in (S. Caplan), 421
 Labour. See also Obstetrics
 LACEY, F. H. (and W. E. FOTHERGILL): End-results of plastic vaginal operations for genital prolapse, 892
 LACKIE, Lamond: Twilight sleep, 341
 Lactation and childbirth, 448
 LAING, Frederick: *The Cockroach: Its Life-History and How to Deal with it*, 614
 LAIRD, Janet Stewart, Serbian Order of St. Sava conferred upon, 446
 LAIBERT, Lieut.-Col. Frederick S., appointed an Esquire of the Order of St. John of Jerusalem, 253
 Lameness and deformity, prevention of (leading article), 203. See also Orthopaedics
 Lamp, parabolic reflector, 796
 Lancashire, medical deputy-lieutenants for, 833
Lancet comes under new control, 661
 LANDIS, Henry R. M. (and George William NORRIS): *Diseases of the Chest and the Principles of Physical Diagnosis*, rev., 306
 "Langham" telephone exchange, 398
 LANGLEY, George J.: Note on lymphadenoma, 667. (O)—(and others): Residual vaccines, 846. (O)
 Langley prize in tropical medicine, 828. See also Tropical
 LANGMEAD, F.: Congenital syphilis, 460
 LANGWILL, Hamilton G.: Treatment of stammering, 384
 LANZ, Otto, resigns from Société Internationale de Chirurgie as a protest against the exclusion of surgeons of Central Europe, 51
 Lard, nutritive value of, 501
 LARDENNOIS, G. (and J. BAUMEL): *Les infections gangréneuses des membres consécutives aux plaies de guerre*, rev., 708
 LARKAM, E. T.: Treatment of erysipelas, 36
 LARKING, Arthur E.: Refraction work among school children, 759
 Laryngoscopy, explosion of ether vapour during (W. J. McCardie), 528
 LASBURY, F. O. (and R. B. COLEMAN): Bilharziasis treated by antimony tartrate, 299. (O)
 LASLETT, E. E.: Pain in paroxysmal auricular fibrillation, 703
 LASSALLE, C. F.: *Report on Anopheles Survey of the Colony of Trinidad and Tobago*, 238
 Latinity, decline of in France, 36
 Laundry hygiene, 714
 LAURIE, Caspar Robert, obituary notice of, 724
 LAURIE, R. Douglas: Melæna neonatorum treated by blood transfusion, 527
 LEACHMAN, E. C.: *Light as an Aid to Publicity: Illuminated Signs*, 711
 Lead, action of water on (J. C. Thresh), 558
 Lead, white, use of in painting (parliamentary note), 829
 Leading Articles:
 American university, 864
 Angina pectoris, surgical treatment of, 823
 Annual stock-taking, 824
 Aphasia, a new study of, 863, 946
 Association, the machinery of the, 746—An annual stock-taking, 824
 Auricular fibrillation and flutter, 612
 Biliary calculi, recurrence of, 534
 Constitutional problem, 647
 Encephalitis, lethargic, 93
 Epidemiology, the new, 432
 Fatigue and efficiency, 131
 Fine adjustments, 432
 First Minister of Health (Dr. Addison), 555
 Food factor in pellagra, 310
 Galen, 24
 Genital prolapse, operations for, 903
 Health Ministry, 56
 Hospital problems, 24
 Hospital staffs, 310
 Hospitals, voluntary, report of committee, 902
 Industrial Fatigue Research Board, 203

Leading Articles (continued):

- Infected wounds, studies of, 235
 Influenza pandemic, 1918-19, 355
 Intestinal protozoa endemic in Britain, 276
 Lameness and deformity, prevention of, 203
 Machinery of the Association, 746
 Measles, transmission of, to moose, 500
 Medical education, problems of, 92
 Medicine a science, 822
 Milk supply, 236
 Ministry of Health, 747
 Municipal medicine, 469
 Napoleon, 678
 Physiology and clinical medicine in Sheffield, 648
 Physiology of pain, 571
 Pneumonic complications of measles and influenza, 710
 Poetry and medical men, 276
 Post-graduate school report, 945
 Pre-natal death, 785
 Psychiatrist's review, 394
 Puerperal infection, prevention of, 709
 Puerperal mortality in 1919, 354, 709
 Research in radiology, 500
 Science of etiology, 534
 Scientific papers, preparation of, 612
 Short life tables, 166
 Splenectomy in pernicious anaemia, 470
 Tonsil and adenoid operations in outdoor clinics, 167
 Trinitrotoluene poisoning, 395
 Tuberculosis, epidemiology of, 570
 Tuberculosis Regulations (1921), 678
 Typhoid carriers, 786
 Vaccination of cattle against tuberculosis, 130
 What we cannot afford, 56
 Whitley Councils, 56

- League of Nations: Health office of, 53—Temporary Health Committee, 677—International health work, 825
 League of Red Cross Societies. See Red Cross
 LEASE, James: Glandular fever, 703
 Lecture, Arris and Gale: Function of the kidneys in prostatic enlargement (J. P. Dobson), 289. (O)
 Lecture, Bradshaw: Splenic anaemia; Banti's disease (Sir Berkeley Moynton), 114. (O)
 Lecture, Cameron: Necessity of orthopaedic training (Sir Robert Jones), 181. (O)—Leading article on, 203
 Lecture, Cavendish: The part of the State in the prevention of disease (Christopher Addison), 940
 Lecture, Mackenzie Davidson Memorial: The importance of the infinitely little (W. D. Halliburton), 449. (O)
 Lecture, Sir John Struthers: Pre-natal death (Arthur Robinson), 785
 Lectures, Lettsoman, 61
 Lectures, Oliver-Sharpey: Nature of flutter and fibrillation of the auricle (Thomas Lewis), 551, 590. (O)—Leading article on, 612
 LEDINGHAM, John C. G., elected Fellow Royal Society, 357
 Lee, River (parliamentary note), 951
 Leeds: Department of Pathology, 871—Work-people's hospital fund, 871—General Infirmary, 912—Provision for treatment of children in, 912
 LEES, David: Keratoderma blennorrhagica, 896
 Left-handedness (C. J. Macalister), 123
 LEGUE, Felix (and Edmund PAPIN): *Précis d'Urologie*, rev., 230
 LEHMANN, Walther: *Die Chirurgie der peripheren nervenverletzungen, mit besonderer Berücksichtigung der Kriegs-Nervenverletzungen*, rev., 740
 Leicester, public medical service report, 317
 Leishmaniasis, local, treatment of (Colonel E. J. Erskine Risk), 267—(Lieut.-Col. C. F. Donovan), 302—(Norman Gray), 382—(G. F. Mitchell), 528
 LEITCH, Archibald, appointed director of the Cancer Hospital Research Institute, 325
 LENNE, R. A.: Caesarean section, 604
 LEPINE, J., elected Dean of the Lyons Faculty of Medicine, 267
 Leprosy, antimony in (F. G. Cawston), 419. (O)
 Leprosy treated with sodium gynocardate (Sir Leonard Rogers), 640
Leptospira icteroides, experimental infection with, 169
 LEREBOLLET, P. (and others): *Sympathique et glandes endocrines*, rev., 363
 LESLIE, Robert Murray, death of, 504—Obituary notice of, 548
 LESLIE, Captain Thomas C. C., O.B.E. conferred upon, 917
 Letchworth, conditions of private practice in, 107
 LETCHWORTH, T. W.: Refraction work in school children, 875
 LETHBRIDGE, William A.: Simple goitre in school children, 367
 Letters to a Nurse, rev., 781
 LETTIS, Thomas, obituary notice of, 625
 Lettsoman lectures. See Lectures
 Leucocytic changes in Hodgkin's disease (Professor Stewart), 813
 LEVICK, G. Murray: Action of the intrinsic muscles of the foot and their treatment by electricity, 381. (O)

- LEVY, A. Goodman: Cardiac massage, 856
 LEWIN, Octavia: Risks after operations for tonsils and adenoids in outdoor clinics, 101
 LEWIS, E. C.: Tuberculous adeoitis, 780
 LEWIS, H. K.: Supplement (1918-20) to the Catalogue of Lewis's Medical and Scientific Circulating Library, rev., 645
 LEWIS, Thomas: Oliver-Sharpey lectures on the nature of flutter and fibrillation of the auricle, 551, 590. (O)—*Clinical Disorders of the Heart Beat*, rev., 816—Knighthood conferred upon, 865
 LEWISOHN, R.: Persistence of gastric ulcers after perforation, 613
 LEYS, Norman: Tuberculosis mortality, 510
 LEYTON, A. S. (and H. G. LEYTON): Note on new growth and a reducing substance in the blood, 852. (O)
 LEYTON, O.: Sapsraemic glycosuria, 45?—Use of alcohol in medicine, 609
 Lice, identity of rickettsia bodies in (A. Bacot), 256. (O)
 Liddell and Scott's *Greek Lexicon*, new edition, 315
 Life assurance, albuminuria in relation to (F. Parke Weber), 78. (O), 83—Discussion on, 83
 Life, beginnings of, 64, 103, 141
 Life tables, short (leading article) 166. See also Vital statistics
 LIGHT, Henry: Meatless diets, 906
 Lighting, artificial, 711
 Limbless men, Princess Louise Cottage Hospital, Erskine, report, 242
 Limbs, artificial. See Artificial
 Limp in childhood (John Fraser), 843. (O)
 LINDSAY, Douglas M.: Caesarean section, 604
 LINSSETER, G.: *Les Lipoides dans l'Infection et dans l'Immunité*, rev., 606
 Liqueur, intoxicating, powers and duties of Food Controller transferred to Board of Trade, 576
 LISTER, Cecil, proposed memorial to, 69
 LISTER, Lord: *Six Papers by Lord Lister*, rev., 386
 LITMAN, Simon: *Prices and Price Control in Great Britain and the United States during the World War*, rev., 273
 LITTLE, Andrew: Risks after operation on tonsils and adenoids in outdoor clinics, 321
 LITTLE, E. Graham: Skin disease, its relation to internal disorder, 303
 LITTLE, E. Muirhead: An improved knee-cap, 164
 Liverpool: Paying patients at Mill Road Poor Law Infirmary, 209
 Living organism. See Organism
 Livingstone College. See College
 LIVINGSTONE, Thomas Hillhouse, obituary notice of, 68
 LLEWELLYN, Llewellyn Jones: *Gout*, rev., 271
 LLEWELLYN, T. Lister: Economic aspect in eye injuries, 118. (O)
 LLEWELLYN, T. R., presentation to, 35
 LLOYD, Dr.: Albuminuria in impetigo, 161
 LLOYD, F. G.: Instrumental abortion, 461
 LLOYD, Rickard: Pathology of breast epithelium, 896
 Local Government officers' superannuation (parliamentary note), 576
 Local rates. See Rates
 LOCHRANE, C. D.: Operative treatment of genital prolapse, 894
 LOCK, Norman: Manipulation of the heart for shock, 49
 LOCKHART-MUMMERY, J. P.: Adrenaline in resuscitation, 100, 582—Pruritus ani, 602—Coecycaecal fistulae, 807. (O), 957
 LODGE, William Oliver: Eclipse blindness, 701. (O)
 LOGAN, W. R.: Study of the pneumococcus and streptococcus groups in their relation to influenza, 189. (O)
 LOMAS, Surgeon Captain Ernest Courtney, obituary notice of, 367
- LONDON:
- Advanced lectures in, 786. See also University
 Association of Medical Women's Federation. See Association
 Coroners' inquests in 1920, 549
 County Council. See Council
 District nursing in, 361
 Health of (report of M.O.H.), 853
 Health service for, suggestions, 244. See also Health
 Intercollegiate Scholarships Board, 176, 723
 Post-graduate work in, 169, 170, 178, 942. See also Post-graduate
 Rat extermination in the Port of London, 628
 School children, medical treatment, 50
 School of Tropical Medicine. See Tropical
 Street accidents, 621
 Tuberculosis conference, 872
 University. See University
 Venereal clinics, 506
 And Vienna, 119
 Voluntary principle in, 198. See also Hospitals, voluntary

- London Intercollegiate Scholarships Board, 176, 723
 LONG, Constance E.: *Collected Papers on the Psychology of Phantasy*, rev., 675

- LONG, Edward Charles, C.M.G. conferred upon, 61
 LONGSTAFF, George Blundell, obituary notice of, 794
 LORD, Lieut.-Col. J. R.: *The Story of the Horton (Co. of London) War Hospital, Epsom*, rev., 644
 LORD, Robert E.: X-ray radiation in cancer, 142
 LOUIS XI, note on, 818, 826
 LOVELL, C.: An improved embedding medium, 108
 LOVETT, J. M.: Prevention of puerperal infection, 875
 LOW, George C. (and Elizabeth O'DRISCOLL): Case of *Dubothricephalus latus* infection, 118. (O)—Treatment of trypanosomiasis, 777
 LOWE, E. Cronin: Pathology of influenza, 426
 LOWER, W. E. (and G. W. CRILE): *Surgical Shock and the Shockless Operation through Anaesthesia*, rev., 385
 LUCAS, Geoffrey, presentation to, 476
 LUCKIANI, Luisa: *Human Physiology*, rev., 741
 LUCKESH, M.: *Artificial Light: Its Influence upon Civilization*, 711
 LUCKE, Thomas D. (and J. Stuart Ross): *Anaesthesia in Dental Surgery*, rev., 164
 Lumbar puncture in acute disease, 326
 LUMSDEN, Sir John: Cryptogenic pneumococcal septicaemia, 890. (O)
 Lunacy Act terms (parliamentary note), 438
 Lunacy Acts, definitions in (parliamentary note), 576
 Lunacy certificates (parliamentary notes), 61
 Lunacy, review of book on, 742
 LYNDE, Alex.: An operation performed under difficulties, 622
 Lung diseases, review of books on, 271, 707
 Lymphadenitis, mesenteric, simulating appendicitis (J. W. Struthers), 706
 Lymphadenoma, note on (George J. Langley), 667. (O)
 Lymphoblastosis, acute benign, 649. See also Fever, glandular
 Lymphocytes, fate of the, 905
 LYON, B. B. Vincent: Medical drainage of the biliary tract, 58
 LYSTER, R. A., appointed member of Central Midwives Board, 407
 LYTH, J. C.: Cure of haemorrhoids without operation 265. (O), 403

M.

- MACALISTER, C. J.: Left-handedness, 123—Appointed Deputy-Lieutenant for Lancashire, 833
 MACALPINE, James B.: Symptomless haematuria, 631. (O)
 MACAULAY, Donald Joseph, obituary notice of, 445
 McAUSLIN, James T.: "Harlequin foetus" (hyperkeratosis congenitalis), 355. (O)
 MACCALLAN, A. F.: Ankylostomiasis campaign in Egypt, 674
 MCCALLUM, Hugh A., obituary notice of, 345
 MCCALLUM, W. G.: Pneumonic complications of measles and influenza, 710
 McCANN, F. J.: Instrumental abortion, 461
 MCCARDIE, W. J.: Explosions of ether vapour during laryngoscopy, 528
 MCCARRISON, Robert: *Studies in Deficiency Disease*, rev., 896
 MCCORMAC, H.: Relation of skin disease to internal disorder, 304—(and E. L. KENNWAY): Treatment of aphthia, 415. (O)
 MCCURDY, D. A.: Pruritus ani, 659
 McDONAGH, J. E. R.: Congenital syphilis, 460
 MACDONALD, Angus: Malaria in England, 502
 McDONALD, Archibald: *Essentials of Surgery*, rev., 429
 MACDONALD, J. A., presentation to, 51, 171, 206, 234, 456, 533, 717, 868
 MACDONALD, Peter: Voluntary principle and the Bradford bogey, 137—Case of sudden monocular dilatation of the pupil, 854
 MACDONALD, R. C.: A double retinoscope, 307
 MACDONALD, Lieut.-Col. Thomas Rankin, obituary notice of, 794
 McDONALD, W. M.: Malignant tertian malaria contracted in England, 370
 McDOUGALL, J. Gordon: Herpes and varicella, 340
 Macedonia, treatment of syphilis in (Trevor Hayman Fowler), 930. (O)
 MACEVEN, John A. G.: Tuberculous haemarthrosis of knee, 158
 MACEVEN, Sir William: *The Growth and Shudding of the Antler of the Deer*, rev., 195
 McFADEN, John Howard, obituary notice of, 408
 McFADYEN, Sir John: Bovine tuberculosis, 421
 McFARLANE, W. D.: Caesarean section, 605
 McGAVIN, Brigadier-General Donald Johnston, knighthood conferred upon, 865
 McGIBSON, John, appointed professor of midwifery in the University of Johannesburg, 35
 McGREGOR, Beatrice Anne, Serbian Order of St. Sava conferred upon, 446
 MacGREGOR, G. Scott: Dextrose in cardiac failure, 158
 McHARDY, E.: Venereal disease prevention, 325

- MCLROY, Louise: Morphine in labour, 159—Appointed professor of obstetrics, London School of Medicine for Women, 324—Present at Buckingham Palace party, 407—Sterility, 816
- MCKENDRICK, Souttar: Treatment of gastric and duodenal ulcers, 122
- MCKENZIE, Dab: *Diseases of the Throat, Nose, and Ear*, rev., 463—Elected a corresponding Fellow of the American Laryngological Association, 585
- MACKENZIE, Hector: Exophthalmic goitre, 268 425
- MACKENZIE, Sir James: Theory of disturbed reflexes in the production of symptoms of disease, 147 (O), 243—*Symptoms and their Interpretation*, rev., 605—A defence of the thesis that the opportunities of the general practitioner are essential for the investigation of disease and the progress of medicine, 797. (O)
- MACKENZIE, J.: Formol-gel reaction in syphilis, 854
- MACKENZIE, Sir Merell, laryngologists place a wreath on the grave of, 855
- MCKIE, N. J. presentation to, 287
- MACKINTOSH, J. M.: Prevention of venereal disease, 174
- MACLEAY, Alexander Rose, obituary notice of, 878
- MACLEOD, J. J. R.: *Physiology and Biochemistry in Modern Medicine*, rev., 643
- MACLEOD, J. M. H.: Relation of skin disease to internal disorder, 304—*Diseases of the Skin*, rev., 567—Pruritus ani, 602
- MCMEHAN, F. H. (editor): *The American Year Book of Anesthesia and Analgesia, 1917-1918*, rev., 741
- MACMUNN, James: Treatment of the pre-operative stage of enlarged prostate, 142, 322—Two instruments for genito-urinary surgery, 568
- MCNIFF, M. I.: Vagitus uterinus, 369
- MCOSCAR, J.: Has mixed staphylococcus vaccine been used in infantile eczema? 919
- MACPHAIL, Hector: *Model Answers to Questions on Nursing set by the Medico-Psychological Association*, rev., 465
- MCQUEEN, James M.: Capillary pressure, 955
- MCVEA, Janet, Serbian Order of St. Sava conferred upon, 446
- MCWALTER, James Charles, death of, 242—Obituary notice of, 286
- MAGILL, Mr.: Anaesthetics in plastic surgery, 344
- MAGNER, Canon, murder of (parliamentary note), 316
- MAIR, Robert Slater, obituary notice of, 106
- MARIN, Sir George: Belfast dinner to, 209—Honorary Fellowship of Ulster Medical Society conferred upon, 209
- Malaria: Action of certain special preparations on malarial parasites and their employment in treatment of (Major J. Pratt-Johnson, Major Kenneth Gilchrist and Captain Hay-Michel), 80. (O)
- Malaria, campaign against: In Spain, 165—In Trinidad and Tobago, 238—In Great Britain (parliamentary note), 438—In England, annotation on, 502
- Malaria, malignant tertian, contracted in England, 370
- Malaria in pensioners (Jenner Hoskin), 493. (O)
- Malaria prevention (C. F. Laasalle's report), 238
- Malaria, use of *Vitex peduncularis* in (Lieut.-Col. J. C. S. Vaughan), 186. (O)
- MALCOLM, John D.: Survival after operation for annular malignant disease of the large bowel, 559. (O)
- Malignant disease, dual radiotherapy in (S. Gilbert Scott), 771. (O)
- Malignant disease of large bowel, annular, survival after (John D. Malcolm), 559. (O). See also Cancer
- Malingering, self-inflicted injuries in civilian practice (A. Rundle Short and Cyril H. Walker), 298. (O)
- MANCHE, Surg.-Lieut.-Col., obituary notice of, 624
- Manchester Radium Institute, report, 471
- Mange, sarcoptic, of the dog, in man (W. H. Coates), 495
- MANN, William Slingsby, obituary notice of, 724
- Manometer for intrapericardial pressure, 465
- MANSON-BAHR, P.: Treatment of trypanosomiasis, 777
- MARKET, Major Philip J., Belgian Croix Civique conferred upon, 215
- MARJORIBANKS, Lieut.-Col. J. L.: Adrenaline in resuscitation, 544
- MARSDEN, Walter Gibson, obituary notice of, 106
- Marseilles, trachoma amongst the school children, 702
- MARSHALL, C. F. (and E. G. FRENCH): *Syphilis and Venereal Diseases*, rev., 566—Treatment of venereal disease, 686
- MARSHALL, Claude H. (and S. M. VANSALLO): Further report on the treatment of sleeping sickness, 775 (O), 777
- MARSHALL, C. Jennings: Reconstructive aneurysmorrhaphy in the third part of the axillary artery, 379. (O)
- MARTIN, Lieut.-Col. James Fitzgerald, Belgian Ordre de la Couronne conferred upon, 253
- MARTIN, James H.: Caesarean section, 641
- MARTIN, J. P.: Herpes and varicella, 340
- MARTINDALE, W. Harrison (and W. Wynn WESTCOTT): *The Extra Pharmacopoeia*, rev., 607
- MANSON-BAHR, P. H. (editor): *Manson's Tropical Diseases*, rev., 606
- Massage, cardiac (A. Goodman Levy), 856
- Massage of the heart and resuscitation (J. A. Gunn), 9. (O)—(Robert B. Coleman), 47—(Norman M. Dott), 192—(C. Langton Hewer), 228. See also Resuscitation
- Materialization, review of books on, 427
- Maternity and child welfare: Centres (parliamentary note), 399—Grants for (parliamentary note), 438—Administration (parliamentary note), 504—Report of the Lauriston Home, Edinburgh, 508—English-speaking conference, 627—Report of National League of, 627—Automobile dispensaries for work of in U.S.A., 944—Conference, 959. See also Baby Week
- Maternity home, county, opened at Bishop Auckland, 833
- Maternity homes and children's institutions: Memorandum from Ministry of Health, 97—Revised list of, 504
- Maternity hospital. See Hospital
- MATHER, Alexander William, obituary notice of, 106
- MATTHEW, D. (and C. H. L. RIXON): *Anxiety Hysteria*, rev., 464
- MATTHEWS, Horatio: The true colour of tissues, 216
- MAUBLANC (and RATIÉ): *Guide pratique pour l'Examen médical des Aviateurs des Candidats à l'Aviation et de Pilotes*, rev., 18—English edition, 63
- Mauritius, facilities for tropical research in, 835. See also Tropical
- MAXTED, G.: Eclipse blindness, 756
- MAY, Otto: Venereal disease prophylaxis, 66, 140
- MAYLAND, Leonard, sentence on, 407
- MAYLARD, A. E.: Abdominal pain, 731. (O)
- Mayo Clinic, 681
- Measles and influenza, pneumonic complications of (leading article), 710
- Measles, intussusception, and appendicectomy in a baby seven months old (S. W. Gowriog), 495
- Measles, transmission of to monkeys (leading article), 500; note on, 904
- Meat inspection in Scotland, report of Scottish Board of Health, 507
- Meatless diets, 906
- Medical Acts: Offences under, 215, 324—Prosecution under (John Richard Taylor), 724
- Medical Annual*, rev., 742
- Medical barristers, 661, 918
- Medical bibliography institute established at Naples, 347
- Medical chairmen of Insurance Committees, 288
- Medical Classica Series, 386
- Medical curriculum in Germany, 789
- Medical deputy lieutenants for Lancashire, 833
- Medical Directory, 1922*, 877
- Medical education in China, the advance in, 308, 313
- Medical education, reform in, 20, 52, 88; leading article on, 92
- Medical Golfing Society, 959
- Medical History, Congress, 750, 879, 950—Review of books on, 818
- Medical History, Annals of*, rev., 742
- Medical history, military, 244. See also Military
- Medical institute for Newcastle, 279
- Medical Insurance Agency, report, 788
- Medical legislation in Australia, 439
- Medical magistrates, 35
- Medical members of the Ulster Parliament, 834
- Medical men arrested in Ireland, 319
- Medical missionaries: Chinese honours for, 208—In Kashmir, 714—Wanted for Central Africa, 726
- Medical needs of the Auxiliary Division in Ireland (parliamentary note), 654
- Medical officer of health, action against (Thomas Orr), defendant wins his appeal, 251
- Medical officer of health, duties of, 919
- Medical officers' pay in India (parliamentary note), 618
- Medical officer's salary, Harrow (parliamentary note), 655
- Medical Officers of Schools Association. See Association
- Medical practice abroad, report on conditions of, 272
- Medical Prime Minister (Emile Combes), 826
- Medical profession, collective opinion of, 322, 362, 543
- Medical profession and Health Ministry. See Health
- Medical records. See Insurance
- Medical referees, appointment of (parliamentary note), 951. See also Pensions
- Medical reform in Ireland (R. J. Rowlette), 344
- Medical Register*, rev., 708
- Medical and Dental Students' Register*, rev., 708
- Medical registration, 583
- MEDICAL RESEARCH COUNCIL: First annual report of, 90
- Studies in cerebro-spinal fever, 168
- Report to on the relation of pneumococci and streptococci to influenza (W. R. Logan), 189. (O)
- Report to on studies of infected wounds (Captain S. R. Douglas, A. Fleming, and L. Colebrook), 235
- Report to on intestinal protozoa endemic in Britain (Clifford Dobell), 276
- Report on trinitrotoluene poisoning, 395
- And research in radiology, 536
- And the preparation of scientific papers, 612
- Medical research exhibit at Olympia, 254
- Medical Review of Reviews* (of New York), 841
- Medical scholarships for Serbian girls, 359
- Medical scientific literature, use and abuse of (W. Bulloch), 939
- Medical service on river gunboats in China (parliamentary note), 475
- Medical stores, surplus, disposal of to hospitals, 278, 828
- Medical students in the Defence Force (parliamentary note), 716
- Medical students, instruction of in physics, 134
- Medical students, number of in United States in 1919-20, 547
- MEDICAL AND SURGICAL APPLIANCES AND PREPARATIONS: Anaesthetists' screen, 743
- Appendix clamp, 568
- Catheter holder for intrauterine treatment of gonorrhoea, 569
- Compact warm ether inhaler, 935
- Direct draining rack, the "Rycott," 781
- Duval's lung forceps, modified, 273
- Gas-oxygen-ether outfit, improvements for use with, 19
- Genito-urinary surgery, instruments for, 568
- Knee-cap, improved, 164
- Manometer for intrapericardial pressure, portable, 465
- Mentholax ointment, 307
- Mouth gag, improved, 127
- Nasal "aseptoids," 232
- Pelvic drain, device to assist in introduction of, 197
- Poisoning, outfit for immediate treatment of cases of, 232
- Retinoscope, a double, 307
- Reverdin needle and holder, a standardized, 465
- Scotometer, a direct record, 645
- Soloid neutral red, 127
- Surgical needles, 127
- Syringe for treatment of the posterior urethra, 708
- Tuberculin administration, tray for, 273
- Urethral drainage bougie, 645
- Medical women, London County Council and, 400
- Medicinal herbs, 60
- Medicinal Plants, Cultivation of in Scotland* (R. Glode Guyer), 960
- Medicine, alcohol in. See Alcohol
- Medicine, comparative, 356
- Medicine of ancient Egypt, 472
- Medicine, history of. See Medical history
- Medicine, municipal (leading article), 469
- Medicine, preventive, 346
- Medicine in public life (medical dinner at Exeter), 532
- Medicine, review of books on, 18, 195, 346, 643
- Medicine as a science (Sir James Mackenzie), 797 (O)—Leading article, 822
- Medicines, flavouring agents in, 27
- Medicines for panel patients (parliamentary note), 29
- Medicines, patent. See Proprietary medicines
- MEDICO-LEGAL: Action against a medical officer of health (Thomas Orr) who wins his appeal, 251
- Definition of insanity, 104
- Herbalist sentenced for performing an illegal operation (Leonard Mayland), 407
- Offences under the Medical Acts, 215, 324
- Prosecution under the Medical Act (John Richard Taylor), 724
- Suicide and the Workmen's Compensation Act, 34
- Melaena neonatorum treated by blood transfusion (R. Douglas Laurie), 527—Correspondence on, 791. See also Blood and Haemorrhagic disease
- MELLANBY, E.: Vitamins, 779
- MELVILLE, Norbert, J.: *Standard Method of Testing Juvenile Mentality by the Binet-Simon Scale and the Porteus Scale of Performance Tests*, rev., 817
- Memories and Musings of a House-Surgeon*, rev., 232
- Meningitis, cerebro-spinal, lingual application of iodine as a prophylactic in (J. A. Taylor), 776. (O). See also Cerebro-spinal
- Menstruation, vicarious (Bethel Solomons), 85; discussion, 85
- Mental deficiency tests, 36
- Mental tests (Binet Simon scale), 817
- Mental therapeutics and the public, 948
- Mentality of hospital patients. See Hospital

- Mentholax ointment, 307
 Metabolism, review of books on, 566
 Metal limbs, light, in above-knee amputations (Edred M. Corner), 524. (O)
 METCALPE, James: X-ray radiation in cancer, 142
 Methylene blue in local leishmaniasis. *See* Leishmaniasis
 Metropolitan Asylums Board. *See* Board
 Mexico, investigations into yellow fever in, 396
 MICHELLI, P. J., knighthood conferred upon, 58, 61
 MICHE, William Adam Smith, obituary notice of, 878
 Microbiology, review of book on, 643
 Microsporion, unusually virulent variety of (Robert Craik), 672
 Midhurst Sanatorium. *See* Sanatorium
 Midwifery practice, physiological principles in (John S. Fairbairn), 415. (O)
 Midwifery, review of books on, 18
 Midwives Board. *See* Board
 Midwives, pupil, L.C.C. and the training of, 63
 MILES, Thomas George, obituary notice of, 286
 MILES, W. E.: Pruritus ani, 603—Coccygeal fistulae, 915
 Military medical history professor at the R.A.M. College, London, 244—Correspondence on, 325. *See also* College
 Milk, condensed, draft regulations (parliamentary note), 505—Skimmed, labelling of, 538—Unswetened (parliamentary note), 576
 Milk and Dairies Bill, 316
 Milk, goat's, 651
 Milk prices (parliamentary notes), 716, 829, 951—Wholesale and retail, 951
 Milk, pure and clean, 866
 Milk regulations, 586
 Milk supply (leading article), 236—To nursing mothers, Ministry of Health circular, 541
 Milk, tuberculous, 54, 141, 174, 302—Reports to London County Council, 302
 MILLER, Arthur Alphonse, French Legion of Honour conferred upon, 515
 MILLER, Douglas A. (and James Young): Etiology of eclampsia and the pre-eclamptic state, 486. (O)—Placenta praevia associated with post-partum eclampsia, 496
 MILLIGAN, E. T. C. (and R. E. Ford): Fracture of first rib, 191. (O)
 MILLIGAN, Sir William: Diathermy for inoperable growths, 461, 855
 MILNE, Lieut. Col. George Wardlaw, obituary notice of, 406
 Miners' housing, 539
 Miners, silicosis and tuberculosis among, report of Miners' Phthisis Medical Bureau, 26
 Ministry of Health. *See* Health
 MINNS, Captain Allan Noel, obituary notice of, 690
 Missionaries, medical. *See* Medical
 MITCHELL, Alex.: Acute osteomyelitis of the long bones in children, 807. (O)
 MITCHELL, G. F.: Treatment of local leishmaniasis, 528
 MITCHELL, S. Weir S. W. Mitchell Oration', (Charles W. Burr), 396
 MITHELL, Thomas E.: Sapræmic glycosuria, 459
 MITCHELL, William: X-ray radiation and cancer, 401
 Mitral stenosis, auricular fibrillation, and the action of digitalis (C. H. Cattle), 521. (O)
 Mitral stenosis and cardiac peristalsis (D. W. Samways), 490. (O)—Correspondence on, 542, 688. *See also* Heart and Blood pressure
 MURRA, Kinnosuke, G.C.V.O. conferred upon, 725
 MODI, Rai Bahadur Jaising P.: *Elements of Hygiene and Public Health*, rev. 499
 MOHENDRA, Nath Baujee, C.I.E. conferred upon, 865
 MOBILE, Captain Kishan Ganesh, Military Cross conferred upon, 917
 MOIR, William, obituary notice of, 584
 MOLLISON, W. M.: Risks after operations on tonsils and adenoids in outdoor clinics, 365
 MOND, Sir Alfred: Declaration of policy, 751
 Monoclia, scientific expedition to, 350
 Monkeys, transmission of measles to (leading article), 500
 MONOD-WALTER, Gustave: Demonstrates the study of movement films, 287, 359—Co-operation between France and Britain, 325
 Mononucleosis, infectious (T. P. Sprunt and F. A. Evans), 95
 MONSARRAT, K. W.: The indications for cholecystectomy, 371. (O)
 MONTAGUE, A. J. H., presentation to, 106
 MONTAGUE of BEAULIEU, Lord (and others): British aid for men of letters and science in Russia, 65
 Moor, F.: Intermittent albuminuria in children, 671. (O)
 MOORE, Alfred: *The Rat and How to Kill Him*, rev., 708
 MOORE, Benjamin: The beginnings of life, 141
 MOORE, Lieut.-Col. Henry, memorial to, 62
 MOORE, Irwin: Eversion of the sacculus laryngis, 855
 MOORHEAD, T. Gillman: Fatal poisoning from inhalation of acid fumes in a laboratory, 83—Elected King's Professor of Materia Medica in Ireland, 245
 Morbidity, post-operative, and anaesthesia. *See* Anaesthesia
 MORGAN, Thomas Hunt: *Physical Basis of Heredity*, rev., 464
 MORLEY, Arthur S.: Cure of haemorrhoids without operation, 364, 441
 MORLEY, D. E. (and Stanley E. DENTON): Case of myoclonic encephalitis lethargica simulating hydrophobia, 191. (O)
 MORLEY, E. B. (and H. Lethbey Tidy): Glandular fever, 452. (O)
 Morphine in labour (Louise McIlroy), 159
 MORRISON, William, obituary notice of, 446, 724
 MORSON, Clifford (and G. S. MOTHERSILL): Suprapubic drainage of the bladder, the De Pezzer tube, 418. (O)
 Mortality, infantile: Congress in London, 1921, 23—Lectures on, 69—Of illegitimate children, 627—In New York, 839
 MORTON, Charles A.: Infection of the supra-clavicular region in cancer of the breast, 173
 MORTON, Charles James, obituary notice of, 958
 MORTON, E. J.: Risks after operation on tonsils and adenoids in outdoor clinics, 321
 MORTON, Hugh, prosecution of under the Venereal Diseases Act and the Medical Act, 795
 MORTON, Reginald: X-ray radiation and cancer, 172, 283
 MOSS, Basil E.: "The Buff Book," 842
 MOSS, W. L.: Diphtheria carriers, 27
 MOSSE, Lieut.-Col. Charles George Drummond, obituary notice of, 690
 Mother, the unmarried, 749
 MOTHERSILL, G. S. (and Clifford Morson): Suprapubic drainage of the bladder, the De Pezzer tube, 418. (O)
 MOTHERSOLE, R. D.: Hemicolectomy, 213
 Motor cars, three-wheeled runabout (Cambro monocar), 482—Taxation (parliamentary white paper), 626
 Motor fuel economy trials, 397
 Motor notes for medical men (H. Masaae Buist), 22, 389
 Motor scooters, 108
 MOTT, Sir F. W.: Relation of skin disease to internal disorder, 304—Congenital syphilis, 345—Reviews: Paul Flechsig's book on cerebral development and function, 529—Reviews: Professor Henschen's book on sensory aphasia, 706
 MOULNIER, René (and René CRUCHET): *Le Mal des Aiguilles: Ses Causes et ses Remèdes*, rev., 18—English edition, 63
 MULLIN, J. A. Mansell: Instrumental abortion, 461
 MULLTON of BANK, Lord, death of, 433
 Mouth gag, improved, 127, 180
 Mouth sepsis. *See* Sepsis
 Movement, films illustrating the study of, 287, 359
 MOYNIHAN, Sir Berkeley: Gastric ulcer, 35—Bradshaw Lecture on splenic anaemia, Banti's disease, 114. (O)—Survey of surgery, 506
 MUIR, Ernest, Kaiser-i-Hind medal conferred upon, 865
 MUIR, Robert: Haemochromatosis and bronzed diabetes, 461
 MULLEN, J. W., presentation to, 879
 Municipal medicine. *See* Medicine
 MUNSON, Francis M.: *Hygiene of Communicable Diseases*, rev., 568
 Murder of Canon Magner. *See* Magner
 MURRAY, F. Anderson: Dermatitis caused by a bitter orange, 739
 MURRAY, Flora: *Women as Army Surgeons*, rev., 346
 MURRAY, G. R., appointed Deputy-Lieutenant for Lancashire, 833
 MURRAY, R. W., appointed Deputy-Lieutenant for Lancashire, 833
 Muscle re-education in infantile paralysis, 33, 67, 175
 Muscles of the foot, action of the intrinsic, and their treatment by electricity (G. Murray Leveik), 381. (O)
 Muscle-tonus, tonic rigidity, and tonic fits (Sir James Purves Stewart), 217. (O)
 Muscular dystrophy, idiopathic (H. S. Carter and W. Fleming), 809. (O). *See also* Dystrophy
 Muscular work, physiological cost of, measured by the exhalation of carbon dioxide (A. D. Waller and G. De Decker), 669. (O)—(Leoard Hill and J. A. C. Campbell), 733. (O)
 Museum, Wellcome, war section of, 314
 Mycological research laboratory founded at Oporto, 702
 Myelocoele, unusual case of (A. J. Cokkiis), 380. (O). *See also* Spina bifida
 MYLES, Surgeon Commander Thomas William, C.B.E. conferred upon, 34
 Myoclonic encephalitis. *See* Encephalitis
 Myopia, high, 35

N.

- NABARRO, D. N.: Congenital syphilis, 344
 Naevi in children (Duncan Fitzwilliams), 605—Correspondence on, 726
 Nails, diseases of, 107
 NANJAPA, C. A., obituary notice of, 514
 NANKIVELL, A. T.: Relation of the laboratory to preventive medicine, 529—Presentation to, 549
 Naples. *See* Italy
 Napoleon, centenary of (leading article), 678

- Napoleon and Murat, 722
 Nasal accessory sinuses, involvement of the orbit in diseases of (Robert E. Wright), 561. (O)
 Nasal "aseptoids," 232
 Nasal deformities, surgery of (Douglas Guthrie), 896
 NASH, E. H. T.: School punishments, 312
 NASH, J. T. C.: Evolution in relation to disease, 543
 NASH, W. Gifford: Torsion of testis in an infant, 267—Herpes and varicella, 340
 Nasopharyngeal catarrh. *See* Catarrh
 National Deposit Friendly Society and support for hospitals, 712
 National Medical Union protests against the new insurance record cards, 145
 Nature, special number of, on the principle of relativity, 326
 NAVY, ROYAL:
 Admiralty surgeons' fees (parliamentary note), 618
 Estimates, 908
 Hospital at Yokohama (parliamentary note), 476, 576
 Influenza epidemic (Surgeon Commander S. F. Dudley), 705
 Medical service of, correspondence on, 67, 143, 176, 248, 285, 323
 Naval medical vote (parliamentary note), 908
 Pneumonia attributable to naval service (parliamentary note), 654
 Regulations re promotion, 958
 Royal Naval Dental Service, 537
 NEAL, James: X rays for ringworm, the risk of baldness, 32
 NEAME, H.: Congenital syphilis, 460
 Neck tumour. *See* Tumour
Nederlandsch Tijdschrift voor Geneeskunde to increase its price, 51
 Needle in a semilunar cartilage, 108
 Needle, R-verdin, standardized needle and holder, 465
 Needles, surgical, 127
 Neo-kharsivan in malaria. *See* Malaria treatment
 Neo-kharsivan in sleeping sickness, 773, 777
 Neo-salvarsan in malaria. *See* Malaria treatment
 Nephritis, chronic parenchymatous, renal decapsulation for (Frank Kidd), 378. (O)
 Nerve centres and toxins, 920
 Nerve injuries, review of books on, 530, 740
 Nerve, peripheral, surgery of injuries of in warfare (Harry Platt), 596. (O)
 Nerve suture, results of (Paul G. Dane), 885. (O)
 Nervous diseases, review of books on, 196
 Nervous system, central, the path of toxins to (Martin Butten), 853. (O)
 Neurasthenia, review of books on, 50
 Neurasthenic patients, treatment (parliamentary note), 475
 Neurology, review of book on, 818
 Neurosis, review of book on, 780, 816
 NEVE, Ernest F.: Treatment of the pre-operative stage of enlarged prostate, 211
 NEWBOLT, Mr.: Cyst of brain in a youth of seventeen, 705
 Newborn, artificial respiration in (W. Osborne Greenwood), 601
 Newcastle-upon-Tyne, annual meeting at, 93, 391, 830 (*see also* Association, British Medical)—Medical institute for, 279—Glasgow University Club dinner, 718
 NEWELL, A. G., resigns from Medico-Political Union, 35
 New growth and a reducing substance in the blood (A. S. Leyton and H. G. Leyton), 852. (O)
 NEWMAN, Sir George: *John Keats, Apothecary and Poet*, 905
 NEWNHAM, W. H. C.: Operative treatment of genital prolapse, 894
 NEWSHOLME, Sir Arthur: *Public Health and Insurance. American Addresses*, rev., 165
 New South Wales: Chair of Psychiatry at the University, 684—Hospital maintenance, 684—Sydney Hospital, 684. *See also* Australia
 NEWTON, the late Francis Morley, an appeal, 512
 New Year honours. *See* Honours
 New York: An asthma clinic in, 615—Radium Institute acquires 500 mg of radium, 661—Hospital conference against proposed increase in tariff on surgical instruments, 809—Infant mortality in, 839
 NICHOLS, Robert Thomas, prize, 447
 NICHOLSON, G. W.: Tumours as malformations, 789
 NICOL, James H.: Treatment of gastric and duodenal ulcers, 122
 Nipples, supernumerary, 254, 288, 370, 448
 NISBET, George, obituary notice of, 251
 NOBECOURT, P., appointed professor of children's diseases in the University of Paris, 504
 Nobel Prize, statistics of awards, 208
 NOGUCHI, H.: Experimental infection with *Leptospira icterodes*, 169—Investigations into yellow fever in Mexico, 396—In Northern Peru, 436
 NORRIS, George William (and Henry R. M. LENDIS): *Diseases of the Chest and the Principles of Physical Diagnosis*, rev., 306

Norway, new pharmacopoeia, 661
Nose, review of books on, 272, 463
Nose and throat diseases, diathermy in (W. J. Harrison), 220. (O)
Note-taking in general practice. *See* General practice

Notes, Letters, Answers, etc.

Accessory food factors, name for, 107
Aches commonly called rheumatism, chronic rheumatism or muscular rheumatism, 482
Acid dentifrice, 408, 550
Adrenaline in resuscitation, 482
Age and pensions, 370
Alkaline dentifrices, 692, 726—And the decrease of dental caries, 726
Amazia (amastris), 369
Angio-neurotic oedema, 180
Anthracite stove for cooking and heating water, 959
Appendix communicating with colon, 146
Appendix, "double" ? 762
Arenic, prolonged administration of, 482
Artificial limbs, 69
"Aspirin habit," 691
Baby show, "points" for judging, 959
Blind Gardeners Guild, 692
Blood changes in T.N.T. poisoning, 179
Body, transfusion of, 550
Bottles, graduated, 146
Braille types for blind children, 179
Brass fever, 254
British Ophthalmic Hospital, Jerusalem, 628
"Buff Book," 842, 880, 920
Carcinoma, differential staining in, 796
Catalogues, 108
Catch, a, 920
Cement and CO₂, 448
Chemists' Exhibition, 960
Childbirth and lactation, 448
Corrections, 36, 70, 408, 628
Cricket Club, Southend Doctors', 448
Defaecation, posture in, 36
Delivery of child and placenta in unruptured membranes at term, 108
Dental caries, appendicitis and gastric ulcer, 960
Dentists Bill, 408
Diabetic acid tests, 841
Disclaimer, 550
Drug list, a modernized, 448
Drugs Act, Dangerous, 180
Eczema of infants and mixed staphylococcus vaccines, 919
Elbow surgery, 180
Electro-medical industry, combination of, 370
Electric thermostat, 586
Embedding medium, an improved, 108
Emetine in bilharziasis, 70, 586
Encephalitis lethargica, official pamphlet on, 662
Erysipelas treatment, 36
Excess profits duty, 692
Eye, artificial, care of, 627
Food Education Society, report, 180
Golf, Rules of, 762
Great-grandparents, seven alive, 370
Gunshot wound in skull, effect of, 628, 692
Haemorrhoids cured without operation, 326
Health resort, one way of selecting a, 70, 146
Herpes and varicella, 448, 726, 762, 842
Hygiene of seamen, 842
Icinitamin or Fiseher's solution, 179, 288
Income tax, 36, 69, 145, 179, 216, 254, 288, 326, 369, 407, 447, 482, 516, 549, 585, 628, 662, 692, 725, 762, 796, 841, 880, 920, 959—Excess profits duty, 692
Indexes, the half-yearly, 146
Insect vectors of disease, 369
Intelligence test, 36
Itching following supraorbital herpes, 662, 725
Lamp, parabolic reflector, 796
Latinity, decline of in France, 36
Letchworth, arrangements for private practice in, 107
Lumbar puncture in acute disease, 326
McFadden, J. H., the late, 408
Malaria, malignant tertian, contracted in England, 370
Medical chairmen of Insurance Committees, 288
Medical examination of recruits, 448
Medical officer of health's duties, 919
Medical missionary wanted, 726
Medicinal Plants in Scotland, Cultivation of, 960
Medical research exhibit, 254
Milk regulations, 586
Motor scooters, 108
Month gaga, improved, 180
Mouth sepsis, need for post-graduate instruction in, 842, 920, 960
Myopia, high, 35
Naevi in children, 726
Nails, diseases of, 107
Needle in a semilunar cartilage, 108
Nipples, supernumerary, 254, 286, 370
Oxyuris vermicularis, 880, 920
Pains in the shins, 550
Paratyphoid fever, 842
Parke, Davis, and Co.'s laboratory catalogue, 662
Patellar ligament, aching under, 880
Pathological laboratory work for a V.A.D. nurse, 627

Notes, Letters, Answers, etc. (contd.)

Penis captivus, 662
Pneumonia treatment, 586
Post and proper, 960
Property in a dead body, 216
Prurigo, summer, 796
Pruritus, 326
Psychic phenomena, 880
Puerperal infection, 550
Pupils, dilated, 179, 216, 254
Rabies in southern India, 36
Rat campaign at the Port of London, 628
Riviera, climate of, 586
Rupce exchange, 586
Save the Children Fund, *Record of*, 146
Sea water for internal use, 369, 447
Sex, doubtful, 692
Self-notification, 726
Ship's surgeons, 369
Signs and symptoms, 369, 796
Smilium reptans in Ireland, 550
Skin (?) of a white or coloured person, 796
"Sleepy Dustman," 180
Smelling salts to prevent sea-sickness, 726
Soyer, Alexis, 586
Stethoscope in France, 516
Surgery, work on by Iohannes Tagantius, 880
Syphilis, antiquity of, 216
Tall talisman, 448
Tapeworm, 180
Teapot stirrer, 36
Tennis elbow, 146
Terminological confusion, 628
Three-wheeled runaway, 482
Tionitus aurium, 146, 254
Tissues, true colour of, 216
Toxins and nerve centres, 920
Transfusion of body, 550
Triplets, 70
"Twilight sleep," correction, 408
"T B. officer," 370
Truss fitting, 516
Tuberculosis, 108
Tuberculosis, early diagnosis of, 216
Tuberculosis eradication in man and animals, 550
Tuberculosis, predisposing causes of, 370
Twius, 796
Urethral stricture, prevention of, 762
Urine, chronic retention of arising from prostatic disorder, 692
Vagitus uterinus ? 369

Notification, self, 796

NOTZING, Baron von Schrenck: *Phenomena of Materialization*, rev., 427
Novarsenobillon in rat-bite fever (F. W. Burton-Fanning), 886. (O)
NOVE-JOSSERAND, P. (and others): *Chirurgie Réparatrice et Orthopédique*, rev., 15
NUNN, Philip G., obituary notice of, 26
Nurses, American, who gave their lives in the war, memorial to, 937
Nurses' Fund. *See* Fund
Nurses' Registration Acts (1919), and uniform for registered nurses, 325—Parliamentary note, 618, 694
Nurses' Registration Act in Australia, 439
Nurses, scarcity of in Vienna, 725
Nurses, textbooks for, 817
Nursing Council, General, new offices and new address, 918
Nursing service of the Royal Air Force. *See* Air

O.

O'BEIRNE, J. J. R.: *Serbo-Croatian Self-Taught by the Natural Method*, rev., 568
Obstetric practice amongst the Akiknyu tribe of Kenya Colony, British East Africa (H. R. A. Philp), 16
Obstetrics, review of books on, 740
Obstruction, acute intestinal (E. R. Flint), 729. (O)
Obstruction, intestinal, by a band, in a large scrotal hernia (Philip Turner), 738. (O)
Obstruction, intestinal, prevention of after ventrofixation (Alexander Don), 563—(R. Stewart), 639
O'CONNELL, Colonel Matthew Daniel, obituary notice of, 253
O'CONNOR, Sir John: Radical cure of varicocele, 738. (O)
Ocular palsies, discussion at Royal Society of Medicine, 426
Ocular symptoms in the slighter cases of encephalitis lethargica (Ransom Pickard), 851. (O)
ODELL, William: A medical missionary wanted, 726
ODLING, William, obituary notice of, 324
O'DONOGHUE, C. H.: *An Introduction to Zoology*, rev., 935
O'DRISCOLL, Elizabeth (and George C. Low): Case of *Dibothriocephalus latus* infection, 118. (O)
Oedema, angio-neurotic, 180, 480, 545
Oedema, angio-neurotic, treated by injections of horse serum, 68, 102
Oedema and capillary pressure (Leonard Hill), 767 (O). *See also* Capillary pressure
Oesophagus, digestion of, as a cause of post-operative and other forms of haematemesis (J. Hogarth Pringle, Laurence T. Stewart, and J. H. Teacher), 563
Officers' alternative pensions, 917

Officers' Families Fund. *See* Fund
"Officers' Friend," 144. *See also* Pensions Ministry
OGLVIE, W. H. (and A. W. HALL): Treatment of cutaneous anthrax, 889. (O)
O'GRADY, Lieut.-Col. Standish de Courcy, obituary notice of, 144
Oils, fat-soluble "A" content of, 104
O'KINEALY, Lieut.-Col. Frederick, C.I.E. conferred upon, 61
OLDFIELD, Josiah: Childbirth and lactation, 448
Olive oil soft soap shampoo in pityriasis capitis (K. Worsley Poole), 601
OLLERENSHAW, Robert: Rotation dislocation of the astragalus, 155. (O)—Hospital treatment of fractures, 559. (O)
OMBREDANNE, L. (and others): *Chirurgie Réparatrice et Orthopédique*, rev., 16
O'NEILL, H. T.: Prevention of puerperal infection, 875
Onodi collection of nasal anatomy, 145, 210. *See also* College of Surgeons
OPENSHAW, T. H.: Habitual dislocations, 384
Operation performed under difficulties, 622
Ophthalmic work in Egypt, 503
Ophthalmic work in schools, organization of (N. Bishop Harmani), 782—Correspondence on, 876. *See also* Refraction work
Ophthalmology, prize in (Nicholas Gifford Edmonds), 28
Ophthalmology, review of book on, 707, 934
Ophthalmoscopic appearances in certain rare cases of diabetes (R. T. Williamson), 120
Opium cultivation in China (parliamentary note), 505
Opium supply, from India to Hong Kong (parliamentary note), 438
Oporto, laboratory for mycological research founded in, 702
Optical glass industry (parliamentary note), 505
Opticians Act in Australia, 439
Optophone, the, 574
Oral sepsis, the coming of age of (William Hunter), 859
Orange bitter, dermatitis caused by (F. Anderson Murray), 739
Orbit involvement in nasal sinus disease (Robert E. Wright), 561. (O)
Orchitis from muscular strain (Charles W. Cathcart), 193. *See also* Testicular disease
Organism cultivated from carcinomata, life cycle of (James Young), 933
Organism, the living, and physical science (A. V. Hill), 743
ORR, Thomas, libel action against, Dr. Orr wins his appeal, 251
Orthopaedic apparatus, review of book on, 606
Orthopaedic training in Edinburgh, 135
Orthopaedic training, the necessity of (Sir Robert Jones), 181. (O)—Leading article on, 203
Orthopaedics, review of books on, 16, 85, 642
OSBORNE, W. A.: *William Sutherland: a Biography*, rev., 430
OSLER, Sir William, memorial to, 165—*Counsels and Ideals*, second edition, 947
Osteomyelitis, acute, of the long bones in children (Alex. Mitchell), 807. (O)
Otitis media, chronic suppurative (F. Holt Diggle), 600. (O)
OVARIES in mammary cancer, ablation of, 615
OVERBECK-WRIGHT, A. W.: *Lunacy in India*, rev., 742
OWEN, Sir Isambard, resignation of, 840, 871
OWENS, Henry Barton, obituary notice of, 250
Oxford Ophthalmological Congress. *See* Congress
Oxyuris vermicularis, 880, 920

P.

PACKARD, F. R.: *The School of Salernum: Regimen Sanitatis Sclerniatum*, rev., 231—(Editor) *Annals of Medical History*, vol. iii, rev., 742
Pain, physiology of (leading article), 571
Pain relieved by posterior rhizotomy (Sir William Thorburn), 629. (O)
Pain in the shins, 550
Palate, cleft, new principle in surgical treatment of (H. D. Gillies and W. Kelsey Fry), 335. (O)
PALMER, W. H.: Diphtheria and follicular tonsillitis, 527
PALMER, W. M., elected a Fellow of the Society of Antiquaries of London, 918
Palsies, ocular, discussion at the Royal Society of Medicine, 426
Palsy, bilateral hypoglossal, due to gunshot wounds (Harold Burrows), 776
Panama Government's memorial to General Oorgas takes the form of a tropical diseases institute, 583, 615
PAPIN, Edmund (and Félix LEGUE): *Précis d'Urologie*, rev., 230
PARAF, J.: Epidemic hicough, 28
Paralysis of vocal cords. *See* Vocal cords
PARAMORE, R. H.: Operative treatment of genital prolapse, 894
Parasites of malaria. *See* Malaria treatment
Paratyphoid fever. *See* Fever
PARDINGTON, G. L.: Senescence and halnotherapy, 193
PARHAM, William Maskelyne, obituary notice of, 724

Paris: Post-graduate instruction in, 210, 215, 239, 325, 481, 585, 795, 841—Edinburgh medical students in, 400—Stele erected at the Hotel-Dieu in memory of internes of the hospitals who died on active service, 739—Fees for medical men called in by police to be increased, 919

Parke, Davis, and Co.'s laboratory products catalogue, 662

PARKER, Charles A.: Suggestions for a co-operative health service for London, 244

PARKER, George, appointed Deputy Lieutenant for Lancashire, 853

PARKER, W. Rushton: Photographs of cretins, 574

Parkes Memorial Prize, 96

Parliament, Medical Notes in:

Addison, Dr., 575

Admiralty surgeons' fees, 618

Anatomical studies, 654

Antimony treatment for ex-service men, 476

Appeal tribunals. *See* Pensions

Approved societies and hospitals, 576

Arsenobenzol treatment of venereal diseases, 753

Artificial limbs, 476, 654—Light metal, 654

Bellahouston Hospital, Glasgow, 618, 716, 869, 908

Bilharziasis treatment, 753

Blind Persons Act, 505

Blind welfare, advisory committee, 475

Board of Education, estimates, 575

Bradford Municipal Hospital, 540

Bronley, whole-time medical officer for, 438

Budget, 652

Cancer increase, 438

Caravan settlement, 654

Casualties, war, 715

Census, 716

Chemicals among the key industries, 753

China, medical service on river gunboats in, 475

Chinese flour, 316

Civil Service estimates, 575

Colonial Medical Service, 869

Coroners' Remuneration Bill, 505, 576, 908

County councils and tuberculosis treatment, 576

Criminal law amendment, 618, 951—The Bishop of London's Bill, 437—Report in the Lords, 474

Dangerous Drugs Act: Draft Regulations, 315, 360, 398, 474, 715, 733—Farmers and, 361—And Ireland, 950

Dentists Bill, 29, 361, 438, 618, 682, 715, 868, 908, 950

Divisional and full-time health insurance officers, 61

Dogs Bill, 316, 618, 869

Drugs, dangerous, in India, 438

Dundrum Asylum staff, 716

Encephalitis lethargica, 618

Ex-service men: In asylums, 61, 505, 716, 952—Tuberculosis, 361—Antimony treatment of, 476—In mental hospitals, 716

Food values, 393

Food in war and peace, 476

Foods, economical, pamphlet, 683

Glamorganshire County Asylums, 438

Glasgow Pensions Committee and the Bellahouston inquiry, 869. *See also* Bellahouston

Harrow medical officer. *See* Medical Health Ministry. *See* Health Ministry in general index

Health services, grants for, 475, 505

Health of soldiers at Cologne, 438. *See also* Venereal

Holloway prison, 951

Hospital accommodation for disabled men, 909

Hospital Finance Committee's report, 474, 753

Hospital ships, sinking of, 361

Housing Bill, 399

Income tax, 316, 951—Assessment, 951

Indian army officers' pensions, 909

Indian Medical Service, 360, 475, 618, 715—Appeals, 683

Industrial Fatigue Research Board, 360, 399

Insurance, National. *See* Insurance in general index

Intoxicating liquor output, powers transferred to Board of Trade, 576

Ireland, medical needs of the Auxiliary Division in, 654

Islington's medical officer, superannuation of, 815

Lead, white, use of in painting, 829

Local Government officers' superannuation, 576

Local Rates (Increase Prevention) Bill, 682

"Lock-up" surgeries, 753

London Hospital: Closing of wards, 909

London University: New buildings, 316—Bloomsbury site, 475, 504

Lunacy Acts terms, 438—Definitions in, 576

Lunacy certificates, 61

Malaria cases in Great Britain, 438

Maternity and child welfare centres, 399—Grants for, 438—Administration, 504

Medical decisions on attributability, 753

Medical needs of the Auxiliary Division in Ireland. *See* Ireland

Medical officer of health: Whole-time, for Bromley, 438—Of Harrow, salary of, 655

Medical officers in India, pay of, 618

Parliament, Medical Notes in (cont.):

Medical officers and pensions examinations, 951

Medical records, 316, 360, 399, 438, 475

Medical referees, appointment of, 951

Medical service on river gunboats in China, 475

Medical students in the Defence Force, 716

Medicine for pauper patients, 29

Metal limbs. *See* Artificial limbs

Milk, condensed, draft regulations, 505—Unsweetened, 576

Milk and Dairies Bill, 316

Milk prices, 716, 829, 951; wholesale and retail, 951

Ministerial changes, 540

Murder of Canon Mauger, 316

Naval Hospital at Yokohama, 476, 576

Navy, Royal, Admiralty surgeons' fees, 618

Nourishment patients' treatment, 475

Nurses' National Fund, 476

Nurses' Registration Acts, 618, 654

Opium: Supply from India to Hong Kong, 438—Cultivation in China, 505

Optical glass industry, 505

Parliamentary Medical Committee, 475, 576

Parliamentary session, 28

Pension patients in mental hospitals, 870. *See also* Pensions in general index

Pneumonia attributable to naval service, 654

Post-graduate instruction, 616

Prison medical officers, 361

Proprietary Medicines Bill, 398

Public health and local rating, 574

Public Health (Officers) Bill, 576, 618, 829, 868, 950

Public medical officers, security of tenure of, 399

Rabies outbreaks, 951

River Lee, 951

Sanatorium benefit, termination of, 438

Scottish Board of Health, 475, 575—Estimates, 575

Scottish Universities Bill, 715, 951

Serums, standardization of, 399

Small-pox, revaccination for, 683; and vaccination, 716

Soldiers at Cologne, health of, 438

Spallinger treatment for consumption, 360, 683

State contributions to health services, 475

Thermometers, clinical, 438

Tuberculosis Bill, 399, 616, 652, 682, 753

Tuberculosis treatment, 438, 653, 829—Expenses, 653

Tuberculosis mortality, 399, 504

Tuberculosis ex service men, 361

Unemployment and sickness benefit, 716

Universities and colleges, grants to, 654—Estimates, 575, 829

Universities (Scotland) Bill, 829

Vaccination, 61

Deaths associated with, 951

Venereal disease: On the Rhine, 438, 475—Civil policy as to, 475—Propaganda to check, 505—Amongst seamen, 683—Value of treatment for, 716—Arsenobenzol treatment of, 753

Venereal disease report, 399—Discussion in the Lords, 473

War: Termination of, 576—Enlistments and casualties, the gross figures analysed, 715

Washington Labour Convention, 829

Wellhouse Hospital, Barnet, 438

Welsh Board of Health, 9

White lead. *See* Lead

Parliamentary candidates, prospective, for the combined English university constituency, 368

Parliamentary Medical Committee, 475, 576

Parliamentary representation of Scottish universities, 953

Parliamentary session, the new, 240, 280

PARRY, R. H.: Lines of advance in the surgery of breast cancer, 99

PARSONS, Allan O.: Prognosis in encephalitis lethargica, 172

PARSONS, H. Compin: Insect vectors of disease, 369

PARSONS, Major Harry Compton, Belgium Croix de Guerre conferred upon, 253

PARSONS, John Herbert, elected Fellow Royal Society, 357

PARSONS-SMITH, Basil: Subacute bacterial endocarditis, 43, (O)

PASCOE, Major James Sydney, obituary notice of, 178

Pasteur Institute of Southern India, report, 36

Patent medicines. *See* Proprietary medicines

Patents, interdepartmental committee appointed dealing with inventions by workers aided by public funds, 326

PATERSON, Keppie: Twilight sleep, 342

PATERSON, William: Willeeden municipal clinics and hospital, 171

Pathological research applied to medicine, 616

Pathology, review of books on, 707

PATON, D. Noel (and A. WATSON): Etiology of rickets, 594, (O)

PATON, Leslie: Ocular palia, 426

PATRICK, Adam: Renal diabetes, 779

PATEN, B. M.: *The Early Embryology of the Chick*, rev., 347

Paying patients: At a Liverpool Poor Law infirmary (Mill Road), 209—At the Bristol hospitals, 832

Pearl pathology, 827

PEARSE J. S.: Tuberculosis, 108

PEARSON, Kayl (and Julia BELL): *A Study of the Long Bones of the Human Skeleton*, rev., 121

PEARSON, Vere: Artificial pneumothorax, 814

PEARSON, William: Site of operation for empyema, 719

PECK, E. Saville: Future of pharmacy, 948

Pellagra, food factor in (leading article), 310

Pelvic drain, device to assist introduction of, 137

Pelvicmetry in contracted pelvis (David Shannon), 160

PENDBRE, K. F.: Fracture of femur, a simple method of extension, 380, (O)

PENDBRE, Vaughan: Prevention of puerperal infection, 791

Penis capivus, 662

PENNINGTON, Drury: The private clinic system, 938

PENNINGTON, S. B., presentation to, 691

Pension patients in mental hospitals (parliamentary note), 870. *See also* Ex-service men in asylums

PENSIONS:

And age, 249, 370

Appeal statistics, 438

Appeal tribunals, 654, 716—Delay in, 361, 654—Waiting work of, 505—Cases, 505—More tribunals, 716

Bellahouston Hospital, Committee of Inquiry appointed, 840, 869—Parliamentary note, 869. *See also* Hospital

Disability, 361, 399, 475, 654—New warrant, 475

Estimates, 575

Evell colony, 202

Expenditure: The Medical Services, 438

Heart disease, grant for, 576

Indian army officers, 909

Medical boards, 683, 716

Medical decisions on attributability, 753

Medical officers, 829

Medical officers and pensions examinations, 951

Officers' alternative pensions, 917

Officers' Friend, 1144

Permanent, for disabled men, 654

Reassessment of pensions, 951

Tropical diseases, medical treatment for, 576

People's League of Health, Cardiff meeting, 30—Welsh branch to be established, 30

Peptone in asthma (A. G. Auld), 696, (O)

Peripheral nerve. *See* Nerve

PERKINS, Herbert: Endemicity of intestinal protozoa, 364

Pernambuco, new medical faculty established in, 609

Peru, northern, yellow fever in, 436

PEVERLEY, W. A. (and J. K. HAWORTH): Aneurysm of external carotid artery treated by ligation of common carotid artery and internal jugular vein, 339, (O)

Pharmacognosy, review of book on, 386

Pharmacology, clinical research in, 868

Pharmacology, review of books on, 87

Pharmacopoeia, agreement to draw up a common one between Sweden, Norway, and Denmark, 661

Pharmacopoeia, Extra, rev., 607

Pharmacy, the future of, 948

Pharyngeal pouch, case of (Archer Ryland), 565

PHILIP, H. R. A.: Obstetric practice amongst the Akikuya tribe of Kenya Colony, British East Africa, 16

PHILLIPS, Captain Hugh Richard, Order of the Crown of Italy conferred upon, 515

PHILLIPS, James: Treatment of uterine haemorrhage not associated with pregnancy, 224 (O)—Cure of haemorrhoids without operation, 402

PHILLIPS, Miles: Operative treatment of genital prolapse, 894—Appointed professor obstetrics and gynaecology in the University of Sheffield, 918

Phtisis. *See* Tuberculosis

Physical science and the living organism (A. V. Hill), 743

Physical signs, review of book on, 229

Physiology and anatomy, teaching of. *See* Anatomy

Physiology and clinical medicine in Sheffield (leading article), 618—Correspondence on, 688

Physiology, review of books on, 675, 741, 817

Physiology at South Kensington, 314

PROKARD, Ransom: Ocular symptoms in the slighter cases of encephalitis lethargica, 851, (O)

PICKEN, R. M. F., appointed M.O.H. and port sanitary officer to city of Cardiff, 958

PINCUS, Bedford, resigns superintendship of the Retreat, York, 706

Piles. *See* Haemorrhoids

PINCH, A. E. Hayward: Radium therapy in uterine cancer, 881, (O)

PINSENT, Ellen Frances, appointed a Commissioner of the Board of Control, 325

PINTO-LEITE, H.: Ethnical anaesthesia, 653

Pistany, note on, 879

PITTS, A. T.: Congenital syphilis, 460

Pituitary and diabetes insipidus, 238

Pityriasis capitis, olive oil soft soap as a shampoo in (K. Woreley Poole), 601

PITZMAN, M.: *The Fundamentals of Human Anatomy*, rev., 387

- Placenta praevia associated with *post-partum* eclampsia (Douglas Miller), 496
- Plague, prevalence of: In Java, 210, 267, 661—In Egypt, 661—In Vladivostok, 708—In Siberia, 708. In Russia in Europe, 708
- Plague, case of in Dublin (H. Drury and Sir Arthur Ball), 84
- Plague on shipboard (W. M. Willoughby), 640
- PLARR, Victor G.: The diary of Crosse of Norwich, 232
- Plastic surgery, anaesthetics in (Mr. Rowbotham and Mr. Magill), 344
- PLATT, Harry: Surgery of the peripheral nerve injuries of warfare, 596. (O)
- Pleura, review of books on, 271
- Pneumococcal septicaemia, cryptogenetic (Sir John Lumsden), 890 (O)
- Pneumococci, disease-producing, serological characters of (Richard R. Arnstrom), 259. (O)
- Pneumococci and streptococci, relation of to influenza (W. R. Logan), 189. (O)
- Pneumonia attributable to naval service (parliamentary note), 654
- Pneumonia, treatment of, 586
- Pneumonic complications of measles and influenza (leading article), 710
- Pneumothorax, artificial (Clive Riviere), 810. (O)—Discussion, 814
- Pneumothorax, complete, in an infant, due to pulmonary tuberculosis (Geoffrey Bourne), 526. (O)
- Poetry and medical men (leading article), 276
- Poison, squill, 253
- Poisoning by arsenic, delayed (George St. George), 192
- Poisoning, fatal, from inhalation of acid fumes in a laboratory (T. Gillman Moorhead), 83—Correspondence on, 143, 404
- Poisoning, food, outbreaks of, 170
- Poisoning, outfit for immediate treatment of cases of, 232
- Poisoning, trinitrotoluene (leading article), 395
- Poisoning, trinitrotoluene (T.N.T.), blood changes in, 179
- Poliomyelitis, muscle re-education in, 33, 67, 175
- Poliomyelitis, orthopaedic treatment of (H. A. T. Fairbank), 517. (O)
- POLLOCK, Colonel Charles Edward, C.B. conferred upon, 865
- POLLOCK, W. B. Inglis: Dilated pupils, 254
- POOLE, K. Worsley: Olive-oil soft soap shampoo in pityriasis capitis, 601
- POOLER, H. W.: The notification fee and the end of the war, 916
- Poor Law infirmaries. *See* Infirmaries
- Poor Law medical officers and Local Government returns (Ireland), 656
- Poor Law medical officers' salaries (Ireland), 477
- POPENHOE, Paul (and Roswell Hill JOHNSON): *Applied Eugenics*, rev., 498
- Port Sanitary Authorities Association. *See* Association
- PORTER, Charles: *School Hygiene and the Laws of Health*, rev., 126
- PORTER, Major-General Robert, K.C.B. conferred upon, 61
- Post-graduate Association, Glasgow Medical, 657
- Post-graduate courses: In Vienna, 169, 683, 840—In London, 169, 170, 178, 879, 918, 942—Committee on, 170, 178, 616, 942: report of committee, 942: leading article on, 945—In Paris, 210, 215, 239, 325, 481, 585, 795, 841—In Glasgow, 507, 657—In Naples, 549—Parliamentary note on, 616—In Bristol, 621—At Bordeaux, 878, 919—At the West London Post-graduate College, 918—At Leysin, 918—At Carlsbad, 937
- Post-graduate instruction in mouth sepsis, need for, 842, 920, 960
- Post-operative morbidity and anaesthesia. *See* Anaesthesia
- Post and propter, 960
- Postural deformities. *See* Deformities
- POULTON, E. P.: Acidosis and alkalosis, 508
- POWELL, D. A., dinner to, 841
- POWELL, Sir R. Douglas (and Sir P. Horton-Smith HARTLEY): *On Diseases of the Lungs and Pleura*, rev., 271
- POWER, Sir D'Arcy: *The Education of a Surgeon under Thomas Vicary*, rev., 272—Palliative treatment of aneurysms by wiring, 427
- POWER, F. P., gold medal presented to, 872
- POWER, Thomas, obituary notice of, 368
- PRATT-JOHNSON, Major J. (and Major Kenneth GILCHRIST and Captain HAY-MICHEL): Action of certain special preparations on malarial parasites and their employment in the treatment of malaria, 80. (O)
- Pregnancy and labour in a double uterus (D. Robertson Dobie), 16
- Pre-masseteric fistulae. *See* Fistulae
- Pre-natal death. *See* Death
- Presentations, 35, 62, 106, 178, 210, 215, 234, 241, 253, 287, 325, 368, 400, 407, 476, 506, 515, 516, 549, 691, 879, 919
- Pressure symptoms and cervical ribs (Edwin Bramwell and H. P. Dykeal), 384
- PREST, Edward E.: Calcium in the treatment of pulmonary tuberculosis, 420
- Preventive medicine and public health laboratories (A. T. Nankivell), 529
- Preventive medicine, review of books on, 346
- Preventive medicine, some aspects of (Dr. Goodfellow), 642
- PRICE, Frederick W.: Note on angina pectoris with auricular fibrillation, 339
- PRICE-JONES, Cecil: Diurnal changes in the size of red blood cells, 239—*Blood Pictures: an Introduction to Clinical Haematology*, rev., 387
- PRINCE OF WALES: Elected an Honorary Fellow of the Royal College of Surgeons of England, 135—Presentation to, 407
- PRINGLE, J. Hogarth: Digestion of oesophagus, 563
- Prison, Holloway (parliamentary note), 951
- Prison medical officers (parliamentary note), 361
- Private clinic system. *See* Clinic
- Prize (Robert Thomas Nichols) for discovery and prevention of death in childbirth from septicaemia, 447
- PROFEIT, Colonel Charles W., C.S.I. conferred upon, 917
- Profession of medicine. *See* Medical
- Professional secrecy in the courts of law, 904
- "Prophylactic" and "Metaphylactic," 628
- Proprietary Medicines Bill, 398—Revenue received in payment of patent medicine labels, 795
- Prosecution under the Medical Act (John Richard Taylor), 724
- Prostate, enlarged, function of the kidneys in (J. F. Dobson), 289. (O)
- Prostate, enlarged, treatment of the pre-operative stage of (J. W. Thomson Walker), 71. (O)—Correspondence on, 142, 211, 322
- Prostate, review of books on, 17, 740
- Prostatectomy, suprapubic, stenosis at the internal meatus after (Andrew Fullerton), 301. (O)
- Prostatic disorder causing chronic retention of urine (Herbert T. Herring), 376. (O)—Correspondence on, 441, 544, 688, 692
- Prostatic symptoms and their causes, 545, 623
- PROTT, W. T.: Treatment of trypanosomiasis, 777
- Prurigo, summer, 796
- Pruritus ani: (J. P. Lockhart-Mummery), 602—Discussion at Royal Society of Medicine, 602—Correspondence on, 659
- Pruritus, remedies for, 322
- Pruritus following supraorbital herpes, 662, 725
- Psychiatrist's review (leading article), 394
- Psychiatry, review of book on, 230
- Psychic phenomena, 880
- Psycho-analysis, quack, 133
- Psychological forgetting in relation to lying (Mary Bell), 123 *See also* Forgetting
- Psychology, elementary, in general hospital teaching (William Calwell), 736 (O)—Correspondence on, 793
- Psychology of hospital patients (W. Calwell), 497. *See also* Hospital
- Psychology, review of books on, 162, 530, 675, 780
- Psychoneurosis, review of book on, 125
- Psychotherapy, 168
- Public health and internal organization (G. S. Buchanan), 331. (O)
- Public health laboratories and preventive medicine (A. T. Nankivell), 529
- Public health and local rating (parliamentary note) 574
- Public Health (Officers) Bill, 576, 618, 829, 868, 950—Note on, 668
- Public health, review of books on, 163
- Public medical officers, security of tenure of, (parliamentary note), 399
- Publications, new and forthcoming, 107, 347, 413, 725, 858, 899
- Publishers' announcements, 63, 107, 273, 307, 482, 745, 899
- Puerperal infection, 404, 479, 550, 709, 757, 791, 837, 873, 914
- Puerperal infections: Prevention and treatment of (W. Blair Bell), 693. (O)—Leading article on, 709
- Puerperal mortality in 1919 (leading article), 354, 709
- Puerperal salpingo-peritonitis (Aleck W. Bourne), 495
- PUGH, Gordon: Non operative treatment of surgical tuberculosis, 425
- Pulmonary blood pressure. *See* Blood
- Pupil dilatation, case of sudden monocular (Peter Macdonald), 854
- Pupils, dilated, 179, 216, 254
- PURCHASE, William Bentley, appointed deputy coroner for Eastern District of London, 215
- PURVIS, J. E.: Cambridge diploma in hygiene, 956
- PETTI, V.: *La chirurgia degli Organi di Movimento*, 59
- PYBUS, F. C.: Risks after operation on tonsils and adenoids in outdoor clinics, 174
- PYE-SMITH, Rutherford John, death of, 504—Obituary notice of, 547—Estate and bequests of, 919
- Pyogenic infection of knee-joint, acute, treatment of (A. H. Southam), 884. (O)
- Q.
- Quack psycho-analysis, 133
- Quack remedies. *See* Secret remedies
- Quinine, action of on the pregnant and non-pregnant uterus in the tropics (Walter Fisher), 891
- R.
- R.A.M.C. Roll of Honour, 406. *See also* Army, British
- R.A.M. College. *See* Collegia
- Rabies, in Southern India, 36—In Holland, 482, 784
- Rabies outbreaks (parliamentary note), 951
- Radiological Congress. *See* Congress
- Radiological workers, protection of, 787, 947—Committee constituted, 787. *See also* X-ray and radium protection
- Radiology and electrology, teaching of, 164
- Radiology, research in (leading article), 500—Note on, 536, 787
- Radiology, review of books on, 498, 675
- Radiotherapy, dual, in malignant disease (S. Gilbert Scott), 771. (O)
- Radium Institute, The Manchester Report, 471—The London, report, 609—New York, acquires 500 mg. of radium, 661
- Radium therapeutics, 609
- Radium therapy (Stanley Greco), 270—Discussion on at Edinburgh Medico-Chirurgical Society, 304
- Radium therapy in uterine cancer (A. E. Hayward Pinch), 881. (O)
- Radium and x rays, action of on tumour growth (S. Rusa, Helen Chambers and Gladys M. Scott), 229
- Radiu, dislocation of forwards at the inferior radio-ulnar joint (Lambert Rogers), 639
- RAINY, Harry, appointed medical adviser to the Prison Commissioners for Scotland, 912
- RAMON Y CAJAL, institute of biology named after in Madrid, 253
- RAMSBOTTOM, Albert (and E. M. BROCKBANK): *The Clinical Examination of Diseases of the Lungs*, rev., 707
- RAMSBOTTOM Alfred Ernest W., obituary notice of, 660
- RAMSBOTTOM, E. N. (and Arthur SELLERS): Complement-fixation tests in the diagnosis of tuberculous infections, 47
- RANSON, Professor: Alcohol in medicine, 609
- Rat-bite fever treated by novarsenbillion (F. W. Burtou-Fanning), 886. (O)
- Rat extermination, 241—In the Port of London, 628
- Rates, Local (Increase Prevention) Bill, 682
- RATTE (and MACBLANC): *Guide pratique pour l'Examen Medical des Candidats à l'Aviation et de Pilotes*, rev., 18—English edition, 63
- Rats, ships, and crews' quarters, 866
- RAW, Nathan: A tuberculosis immunizing vaccine, 594. (O)
- RAW, Stanley: The hospital problem, 127
- RAYNES, F. W.: *Domestic Sanitary Engineering and Plumbing*, rev., 858
- Reading Abbey, octocentenary of, 661
- Record card as evidence, 193. *See also* Insurance
- Recruits, medical examination of, 448
- Red, solid neutral, 127
- Red Cross Congress, International, 503, 537, 569—Meeting and resolutions passed, 569
- Red Cross, Czecho-Slovak, organizing work of, 781
- Red Cross, recruiting for, 713
- Red Cross Societies, League of: Annual meeting, 301—Department of social hygiene to be known as department for combating venereal diseases, 590—North European Conference on Venereal Diseases, 682, 909
- Red Cross Society, British, and Order of St. John: Report on home service ambulances, 237 (*see also* Ambulances)—War medal, 240—War finance, 315
- Red Cross Society, Chinese, report 615
- REES, David Valentine, obituary notice of, 660
- REES, Ferdinand: Conference on voluntary hospitals, 66
- Refraction work among school children, 759, 782, 792, 838, 875, 914
- Registrar-General, new, for England and Wales, 135—For Scotland, 136—Annual Report for 1919, 166, 169—Tuberculosis in 1919, 202—Quarterly returns, 472, 656, 784. *See also* Vital statistics
- REID, Sir G. Archdall: Prevention of venereal disease, 139, 245—*Prevention of Venereal Disease*, rev., 161—Treatment of acute toxæmia, 835
- REID, J.: Tapeworm, 180
- Relativity, principle of, 326
- Renal decapsulation for chronic parenchymatous nephritis (Frank Kidd), 378. (O)
- Renal diabetes (Adam Patrick), 779
- Renal function in prostatic enlargement (J. F. Dobson), 289. (O)
- Renal secretion, recent advances in the physiology of (J. S. Haldane), 409 (O)—Leading article, 432
- RENSHAW, Graham: Harlequin fetus, 623
- RENTON, J. Mill: Surgical treatment of chronic sciatica, 557. (O)
- Research Defence Society. *See* Society
- Respiration, recent advances in the physiology of (J. S. Haldane), 409. (O)—Leading article on, 432
- Respiration, artificial, in the newborn (W. Osborne Greenwood), 601
- Resuscitation from apparent death, adrenaline in (Cranston Walker), 46 (O), 100—A disclaimer, 100—Correspondence on, 100, 136, 482, 544, 582

Resuscitation and heart massage (J. A. Gunn), 9. (O)—(Robert B. Coleman), 47—(Norman M. Dotz), 192—(C. Langton Haver), 228
Retinoscope, a double, 307
Reverdin needle and holder, standardized, 465

Reviews of Books :

Advancement of Science (1920), 164
American Gynaecological Society Transactions, vol. 44, 644
American Medical Biographies (Howard A. Kelly and Walter L. Burrage), 306
American Pediatric Society Transactions, vol. 32, 645
Anaesthesia in Dental Surgery (Thomas D. Luke and J. Stuart Ross), 164
Anaesthesia: Précis de Rachianesthésie (G. le Filliatre), 741
Anaphylaxis: De l'Anaphylaxis à l'Immunité (Maurice Arthus), 818
Anesthesia and Analgesia, American Yearbook of 1917-1918 (edited by F. H. McMeenan), 741
Anatomy, Applied, and Kinesiology: The Mechanism of Muscular Movement (Wilbur Pardon Bowen), 17
Anatomy of the Brain and Spinal Cord (J. Ryland Whitaker), 231
Anatomy, Human, Fundamentals of (M. Pitzman), 387
Angina Pectoris (Walter Verdon), 125
Antler of the Deer, the Growth and Shedding of (Sir William Maxson), 195
Aphasia: Klinische und Anatomische Beiträge zur Pathologie des Gehirns (Salomon Eberhard Henschen), 706
Art of Attaining High Health, together with Aristologie or the Art of Dining (T. Walker), 858
Auld Doctor, and other Poems and Songs in Scots (David Korie), 196
Aviators: Guide pratique pour l'Examen Médical des Aviateurs des Candidats à l'Aviation et de Pilote (Drs. Maublan and Ratie), 18
Aviators: Le Mal des Aviateurs: Ses Causes et ses Remèdes (René Cruchet and René Mouliner), 18
Bacteriology, Manual of (R. Tanner Hewlett), 857
Bazaar Medicines, Practical (G. T. Birdwood), 197
Bibliographie des Livres Français de Médecine et de Sciences, 532
Binet-Simon Scale and the Porteous Scale of Performance Tests, Standard Method of Testing Juvenile Mentality by (Norbert J. Melville), 817
Blood of Domesticated Animals, The Clinical Pathology of (S. H. Burnett), 780
Blood Pictures, an Introduction to Clinical Haematology (Cecil Price Jones), 387
Bone Formation, its Relation to Tension and Pressure (Murk Jansen), 565
Brain Injuries, Diagnosis and Treatment of (William Sharpe), 345
Bridge, Royal Auction, Hints on (Lieut.-Col. S. H. Hingley), 465
British Journal Photographic Almanac, 499
Calendars: Of the National University of Ireland, 197—Of University College, University of London, 197—Of the University of Durham College of Medicine 197
Cameron, Sir Charles A., Autobiography of, 387
Canadian Mother's Book, 898
Cancer, Some Conclusions on (Charles Creighton), 49
Cerebral Development: Anatomie des Menschlichen Gehirns und Rückenmarks auf Myelogenetischer Grundlage (Paul Flechsig), 529
Cerebro-spinal Fluid, Physiology and Pathology of (William Boyd), 270
Chemistry, Applied, Dictionary of (Sir Edward Thorpe), 464
Chess Openings, Pocket Guide to (R. C. Griffith and J. H. White), 465
Chest Diseases and the Principles of Physical Diagnosis (George William Norris, Henry R. M. Landis, and Edward B. Krumpholtz), 306
Children and Infants, Diseases of (J. P. Crozer Griffith), 531
Children, Newborn, Diseases of (August Ritter von Reuss), 531
Children, Sick, Clinical Study and Treatment of (John Thomson), 565
Children's Diseases (Sir James Frederick Goodhart), 934
College of Physicians of Philadelphia: Report of Library Committee 676
Communicable Diseases, Hygiene of (Francis M. Munson), 568
Constitution of the United States (Hon. John W. Davis), 607
Consulting Surgeon in the Near East (A. H. Tubby), 230
Deficiency Disease, Studies in (Robert McCarrison), 896
Dentists' Register, 708
Dermatology (W. J. Highman), 676
Diabetes: Le Diabète Sucre (Marcel Labbé), 858
Diary of a Yeomanry M.O. (Egypt, Gallipoli, Palestine, and Italy) (Captain O. Teichman), 898

Reviews of Books (continued):

Diathermy, its Production and Uses in Medicine and Surgery (Elkin P. Cumberbatch), 643
Dictionary, French-English Medical (A. Gordon), 935
Dictionary, A Practical Medical (Thomas Lathrop Stedman), 781
Dictionary of Scientific Terms (I. F. Henderson and W. D. S. Henderson), 51
Domestic Sanitary Engineering and Plumbing (F. W. Raynes), 858
Dysentery, Surgical Aspects of, including Liver Abscess (Zachary Cope), 498
Edinburgh Obstetrical Society, Transactions, 197
Education of a Surgeon under Thomas Vicary (Sir D'Arcy Power), 272
Electrotherapy in Urology: Notions Pratiques d'Electrothérapie appliquée à l'Urologie (D. Courtade), 781
Embryology of the Chick, The Early (B. M. Patten), 347
Empire Municipal Directory of Local Authorities and Officials and Yearbook of "Municipal Engineering and the Sanitary Record" for 1921-22, 935
Endocrines, The (Samuel Willis Bandler), 816
Eugenics, Applied (Paul Popenhoe and Roswell Bill Johnson), 498
Every Man his own Builder (G. G. Samson), 858
Exophthalmic Goitre and its Non-surgical Treatment (Israel Bram), 306
Extra Pharmacopoeia. See Pharmacopoeia Eye cases, the care of (R. H. Elliott), 934
Eye, Surgery of and its Adnexa. Chirurgie de l'oeil et de ses annexes (F. Terrien), 707
First Aid in Emergencies (Eldridge L. Eliason), 87
First Aid to the Injured and Sick (F. J. Warwick and A. C. Tunstall), 568
From Cloud to Sunshine (Alfred S. Gubb), 231
Fry's Royal Guide to the Principal London and other Charities, 56th edition, 87
General Medical Council: Minutes, 347—General Index to the Minutes, 347
General Practice and X Rays (Alice Vance Knox), 346
Glands: Sympathique et glandes endocrines (P. Lereboullet, Harvier, Carriou et Guillaume), 463
Glass-blowing, Laboratory (B. D. Bolas), 743
Gout (Llewellyn Jones Llewellyn), 271
Guy's Hospital Reports, vol. lxxi, 934
Gynaecology (Brooke M. Anspach), 898
Gynaecology, Manual of (John Cooke Hirst), 87
Gynaecology, Operative (Harry Sturgeon Crossen), 163
Hazzel Annual and Almanac for 1921, 164
Heart and Aorta: Le coeur et l'aorte: Etude de radiologie clinique (H. Vaquez and E. Bordet), 498
Heart Beat, Clinical Disorders of the (Thomas Lewis), 816
Heredity, Physical Basis of (Thomas Hunt Morgan), 464
History: L'Histoire éclairée par la clinique (Dr. Cabanes), 818
Horton (Co. of London) War Hospital, Ensom: Story of (Lieut.-Col. J. R. Lord), 644
Hygiene (W. Wilson Jameson), 50
Hygiene and Public Health, Elements of Rai Bahadur Jaising P. Modi), 499
Hypnotism, Experimental and Therapeutic, Introduction to the Study of (H. E. Wingfield), 567
Hysteria, Anxiety: Modern Views on some Neuroses (C. H. L. Rixon and D. Matthew), 464
Industrial Worker, Health of (E. L. Collins and M. Greenwood), 497
Infants. See Children
Instinct and the Unconscious (W. H. R. Rivers), 305
Intestinal Toxaemia or Auto-intoxication in the Causation of Disease (Alexander Bryce), 780
Johns Hopkins Hospital Reports, vol. xxi, Fasc. II, 818
Journal of Comparative Psychology (edited by Knight Dunlop and Robert M. Yerkes), 818
Kystoskopischer Atlas (Erich Wossidlo), 387
Laboratory Glass-blowing Handbook (B. D. Bolas), 743
Labour, An Atlas of Normal (G. Drummond Robinson), 740
Lays by the Wave (R. B. Greaves), 273
Letters to a Nurse, 781
Lewis's Medical and Scientific Circulating Library, Supplement (1918-20) to Catalogue of, 645
Lipoids: Les Lipoides dans l'Infection et dans l'Immunité (G. Linossier), 606
Lister, Lord, Six Papers by (with Notes by Sir Rickman J. Godlee), 386
Long Bones of the English Skeleton. Study of (Karl Pearson and Julia Hell), 124
Lunacy in India (A. W. Overbeck-Wright), 742

Reviews of Books (continued):

Lungs, Clinical Examination of Diseases of (E. M. Brockbank and Albert Ramsbottom), 707
Lungs and Pleurae, Ou Diseases of (Sir R. Douglas Powell and Sir P. Horton-Smith Hartley), 271
Macedonia, A Plea for the Primitives (A. Goff and Hugh A. Fawcett), 272
Manic-Depressive Insanity and Paranoia (Emil Kraepelin), 644
Materialism, Phenomena of Baron von Schrenck Notzing, 427
Medical Annual, 742
Medical and Dental Practitioners, Report on Conditions of Practice Abroad, 272
Medical Formulary, New Pocket (W. E. Fitch), 742
Medical Handbook for the use of Practitioners and Students (R. S. Aitchison), 164
Medical History, Annals of, vol. iii, 742
Medical Register for 1921, 707
Medical and Dental Students' Register, 707
Medical Society of London, Transactions, vol. xliii, 644
Medicine, Bazaar (G. T. Birdwood), 197
Medicine, Essentials of (C. P. Emerson), 858
Medicine, Practical (Alfred H. Carter), 935
Medicine: Nouveau Traité de Médecine, Fasc. I: Maladies Infectieuses (edited by Professors Roger, Vidal, and Teissier), 195
Medicine, Synopsis of (Henry Letheby Tidy), 18
Medicine, Wheeler's Handbook of (William R. Jack), 164
Memories and Musings of a Hospital Surgeon, 232
Metabolic Rate Determinations, Basal, Laboratory Manual of the Technic of (Walter M. Boothby and Irene Sandiford), 567
Microbiology: Précis de Microbiologie clinique (F. Bezançon), 643
Midwifery, Short Practice of (Henry Jellett), 18
Middlesex Hospital at Clacton-on-Sea during the Great War 1914-1919, annals of, 934
Midwifery for Nurses, Practical Textbook of (Robert Jardine), 18
Mother and Child (Edward P. Davis), 818
Muscles, Artificial: Des action musculaires artificielles (G. Bidou), 18
Naturalist on Lake Victoria, with an Account of Sleeping Sickness and the Tsetse Fly (G. D. Hale Carpenter), 86
Nerves, Peripheral: Die Chirurgie der peripheren Nervenverletzungen, mit besonderer Berücksichtigung der Kriegs-Nervenverletzungen (Walther Lehmann), 740
Nervous System: Le sympathique et les systèmes Associés (A. C. Guillaume), 196
Neurasthenia Nervous Exhaustion, Manual of (Ivo Geikie Cobb), 50
Neurological Diagnosis: Leitfaden der Neurologischen Diagnostik (Kurt Singer), 818
Neuroses, Psychology of Functional (H. L. Hollingworth), 780
Neuroses, Treatment of (Ernest Jones), 816
Nose: Catarrhal and Suppurative Diseases of the Accessory sinuses of the Nose (R. H. Skilner), 463
Nose, Paranasal Sinuses, Nasolacrimal Passage-ways, and Olfactory Organ in Man: A Genetic, Developmental, and Anatomico-Physiological Consideration (J. Parsons Schaeffer), 272
Notable Trials. See Trials
Nursing: Model Answers to Questions on Nursing set by the Medical-Psychological Association (Hector Macphail), 465
Ophthalmological Society, Transactions, vol. xl, 568
Orthopaedic Apparatus: Gli Apparecchi Ortopedici (F. Delitala), 606
Orthopaedic and Reconstruction Surgery, Industrial and Civilian (Fred. H. Albee), 85
Orthopaedic Surgery: Chirurgie Réparatrice et Orthopédique (E. Jeanbrau, P. Nové-Josserand, L. Ombredanne, and P. Testosses), 16
Orthopaedic Surgery of Injuries (edited by Sir Robert Jones), 642
Orthopaedics for Practitioners (Paul Bernard Roth), 86
Over and Above (John E. Gordon), 18
Pathology, Chemical (H. Gordon Wells), 707
Peripheral Nerves, Injuries of the (H. Souttar and E. W. Twining), 530
Pharmacopoeia, Scientific and Applied (Henry Kraemer), 386
Pharmacology and Medical Treatment for Nurses Textbook of (J. M. Fortescue-Brickdale), 817
Pharmacology, Practical (W. E. Dixon), 87
Pharmacopoeia Extra (W. Harrison Martindale and W. Wynn Westcott), 607
Phenomena of Materialization (Baron von Schrenck Notzing), 427
Physical Signs in the Chest and Abdomen (A. J. Jex-Blake), 229
Physiology (François Roberts), 817
Physiology, Human (Luigi Luciani), 741
Physiology, Principles of General (William Meddock Bayliss), 675
Physiology and Biochemistry in Modern Medicine (J. J. B. Macleod and others), 643
Practice Abroad, Report on Conditions of, 272

Reviews of Books (continued):

- Preventive Medicine, Principles of (R. Tanner Hawlelt), 346
 Prices and Price Control in Great Britain and the United States during the World War (Simon Litman), 273
 Prostate, Clinical Lectures on Enlargement of (Sir Peter J. Freyer), 17
 Prostate: Le Forage de la Prostate, méthode de Luyz (L. Ecaude), 740
 Psychiatry, Manual of (edited by Aaron J. Rosanoff), 230
 Psychic Structures at the Goligher Circle (W. J. Crawford), 708
 Psycho-analysis, Its History, Theory, and Practice (André Tridon), 531
 Psycho-analysis and Behaviour (André Tridon), 531
 Psycho-analysis, Practical, Elements of (Paul Bouafield), 531
 Psychology of Functional Neuroses (H. L. Hollingworth), 780
 Psychology of Phantasy, Collected Papers on (Constance E. Long), 675
 Psychology and Psychiatry, Practical (C. B. Burr), 465
 Psychology and Psychotherapy (William Brown), 530
 Psychology of the Special Senses (A. F. Hurst), 162
 Psychoneuroses of War and Peace (Millais Culpin), 125
 Public Health and Insurance: American Addresses (Sir Arthur Newsholme), 163
 Public Health Laboratory Work (Chemistry) (Henry R. Kenwood), 50
 Purple Sapphire and other Posthumous Papers (Christopher Blayre), 676
 Radiographic Technique (T. Thorne Baker), 675
 Radiology of Heart: Le Cœur et L'Aorte—Études de Radiologie Clinique (H. Vaguez and E. Bordet), 498
 Radiology: Radiologie et Radiumthérapie (Drs. Béclère, Cottenot, and Mme. Laborde), 676
 Rat and How to Kill Him (Alfred Moore), 708
 Reading Abbey, Octocentenary of, 1121-1921 (Jameson B. Hurry), 899
 Rising Tide and Other Poems (Charles Whitty), 197
 Roentgen Diagnosis of Diseases of the Alimentary Canal (Russell D. Carman), 676
 Roentgenological Technique, Principles and Practice of (I. Seth Hirsch), 126
 School Hygiene and the Laws of Health (Charles Porter), 126
 School of Salerno: Regimen Sanitatis Salernitanum (Francis R. Packard), 231
 Scientific Terms, Dictionary of (I. F. Henderson and W. D. S. Henderson), 51
 Scurvy, Past and Present (Alfred F. Hess), 85
 Sell'a World's Press, 232
 Serbo-Croatian Self-taught by the Natural Method (J. J. O'Farne), 568
 Sex-Complex, the (W. Blair Bell), 86
 Sexual Impotence (V. G. Veckl), 51
 Skin Disease (J. M. H. MacLeod), 567
 Soul in Suffering (Robert S. Carroll), 430
 Sphygmometer, the: Its Value in Practical Medicine (William Russell), 386
 Stone Age in Europe, the New (John M. Tyler), 933
 Surgery (Ivor Back and Tudor Edwards), 429
 Surgery, Essentials of (Archibald McDonald), 429
 Surgery, Operative (Alexis Thomson), 856
 Surgery, Operative, the Course of (Victor Schmieden and Arthur Turnbull), 856
 Surgery, Synopsis of (E. W. Hay Groves), 429
 Surgical Shock and the Shockless Operation through Anoci-Association (G. W. Crile and W. E. Lower), 385
 Sutherland, William, a Biography (W. A. Osborne), 430
 Sympathetic Nervous System: Le Sympathique et les Systèmes Associés (A. C. Guillaume), 196, 644
 Symptoms and their Interpretation (Sir James Mackenzie), 605
 Syphilis (Lloyd Thompson), 429
 Syphilis: Atlas de Syphilimétrie (100 graphiques). Les Conditions Expérimentales de l'Extinction de la Syphilis (A. Verne), 857
 Syphilis in General Practice, with Special Reference to the Tropics (K. K. Chatterji), 196
 Syphilis and its Treatment, with Special Reference to Syphilis of the Skin (Wilfrid S. Fox), 231
 Syphilis and Venereal Diseases (C. F. Marshall and E. G. Fritch), 566
 Thoughts of a Nature Lover (Kenneth Rogers), 607
 Throat, Nose and Ear Diseases (Dan McKenzie), 463
 Traité de Pathologie Médicale et de Thérapeutique appliquée (Emile Sergent, L. Ribadeau-Dumas and L. Babonneix), 306, 397
 Treatment: Die Therapie an den Bonner Universitätsklinik (Rudolf Finkelnburg), 307
 Trials of: The Wainwrights, 272—Thurtell and Huut (edited by Eric R. Watson), 677

Reviews of Books (continued):

- Tropical Disease, War against (Andrew Balfour), 196
 Tropical Diarrheas, Manson's (edited by P. H. Manson-Bahr), 606
 Tropical Medicine, Clinical Methods for Students in (Lieut.-Col. G. T. Birdwood), 898
 Tuberculosis Prevention, National Association's Annual Conference, 126
 Tuberculosis Workers, Handbook for (Noel Bardswell), 126
 Typhus Fever, with Particular Reference to the Serbian Epidemic (R. P. Strong, G. C. Shattuck, A. W. Sellarda, H. Zinsser, and J. G. Hopkins), 857
 Urius: Le Protéine dell' Orina (Emilio Cavazzani), 127
 Urology: Précis d'Urologie (Félix Legueu and Edmund Papin), 230
 Venereal Disease, Prevention of (Sir G. Archdall Reid), 161
 Venereal. See also Syphilis
 Wainwrights, Trial of (edited by H. B. Irving), 272
 War Neuroses as Physiologic Conservations (Sidney I. Schwab), 125
 Wheeler's Handbook of Medicine (William R. Jack), 164
 Women as Army Surgeons (Flora Murray), 346
 World of Sound (Sir William Bragg), 499
 X Rays and General Practice (Alice Vance Knox), 346
 Zoology, Introduction to (C. H. O'Donoghue), 935
 Zoology, Outlines of (A. J. Thomson), 898
Revista de Medicina y Cirugía Prácticas changea its title to *Archivos de Medicina Cirugía y Especialidades*, 347
Revista Médica de Hamburgo, 691
 REYNES, Henry: Ablation of ovaries in mammary cancer, 615
 REYNOLDS, E. D.: Diathermy for inoperable growths, 462
 REYNOLDS, E. S., appointed Deputy Lieutenant for Lancashire, 833
 REYNOLDS, Russell J., appointed radiologist to Charing Cross Hospital, 795
 Rhine: Health of soldiers on, 438—Venereal diseases on, 475. See also Venereal
 Rhizotomy, posterior, for the relief of pain (Sir William Thorburn), 629. (O)
 Rib, first, fracture of (E. T. C. Milligan and R. E. Ford), 191. (O)—Correspondence on, 284
 RIBADEAU-DUMAS, L. (and others): *Traité de Pathologie Médicale et de Thérapeutique appliquée*, rev., 306, 897
 Ribs, cervical, and pressure symptoms (Edwin Bradwell and H. P. Dykes), 384
 RICE, Thomas Edmund, C.M.G., conferred upon, 61
 Ricketts, etiology of (D. Noel Paton and A. Watson), 594. (O)—Correspondence on, 685
Rickettsia pediculi, probable identity of with *Rickettsia quintana* (A. Bacot), 156. (O)
 Ringworm, x rays for, the risk of baldness, 32
 Rio de Janeiro, tuberculosis mortality in, 739
 RISK, Colonel E. J. Erskine: Treatment of local leishmaniasis, 267
 RITTER VON REUSS, August: *The Diseases of the Newborn*, rev., 531
 RIVERS, W. C.: The drooping shoulder sign of phthisis, 120. (O)—Letter on, 441
 RIVERS, W. H. R.: *Instinct and the Unconscious*, rev., 305
 Riviera, climate of, 586, 714
 RIVIERE, Olive: Artificial pneumothorax, 810
Rivista della stampa medica, 347
 RIXON, C. H. L. (and D. MATTHEW) *Anxiety Hysteria*, rev., 464
 ROBERTS, Francon: *Physiology*, rev., 817
 ROBERTS, St. Clair: Cataract in iron workers, 905
 ROBERTSON, Bruce: Blood transfusion in haemorrhagic disease of the newborn, 791
 ROBERTSON, R.: Vaccine therapy in general practice, 194
 ROBERTSON, William L., obituary notice of, 214
 ROBINSON, Arthur: Sir John Struthers's lecture on pre-natal death, 785
 ROBINSON, A. Leyland: Injuries to the female ureter, 665. (O)
 ROBINSON, G. Drummond: *An Atlas of Normal Labour*, rev., 740
 ROBINSON, William: Notes on a giant, 560
 ROBINSON, Wilton H.: Hyperidrosis, 216
 ROBSON, W. Morton: Association of herpes zoster and varicella, 228
 Rockefeller Foundation endows a training college for nurses at Brussels, 725—Representatives in this country to discuss increased activities in the investigation of parasitic tropical diseases, 907—To build a tuberculosis dispensary at Bordeaux, 919
 Rodent ulcer, suggested autoinoculation of (S. C. Dyke), 932. (O)
 ROENTGEN, Professor, monument to, and street named after, in Petrograd, 593
 ROGER (and others, editors): *Nouveau Traité de Médecine*, rev., 195
 ROGERS, Kenneth: *Thoughts of a Nature Lover*, rev., 607
 ROGERS, Lambert: Dislocation of the radius forwards at the inferior radio-ulnar joint, 639

- ROGERS, Sir Leonard: The future of research in tropical medicine, 388, 542—Treatment of leprosy and tuberculosis with sodium glycocholate, 640—Hypertonic saline in treatment of cholera, 673
 ROLLESTON, Sir Humphry: Congenital syphilis, 342, 460—Appreciation of Surgeon Captain Ernest Courtney Lomas, 367—The private clinic system, 938
 ROMANIS, W. H. C.: Exophthalmic goitre, 342
 RONALDSON, Dr.: Twilight sleep, 341
 RÖNTGEN, Professor, elected a doctor *honoris causa* by the Frankfurt Faculty of Natural Science, 304—Twenty-fifth anniversary of his discovery of x rays, 482
 RORIE, David: *The Auld Doctor and other Poems and Songs in Scots*, rev., 196
 ROSANOFF, Aaron J.: *Manual of Psychiatry*, rev., 230
 ROSE, Andrew: "One way of selecting a health resort," 146
 ROSA, Surgeon-Colonel George Cumberlaud, obituary notice of, 584
 ROSS, H. C.: Appreciation of John Howard McFadden, 408
 ROSS, J. Stuart (and Thomas D. LUKE): *Anaesthesia in Dental Surgery*, rev., 164
 ROSS, S. J.: Risks after operations on tonsils and adenoids in outdoor clinics, 213
 ROTH, Paul Bernard: *Orthopaedics for Practitioners*, rev., 86
 ROUS: Fate of the lymphocytes, 905
 ROTT, Ettie A.: Prevention of venereal disease, 212
 ROTH, Amad: Congenital syphilis, 343
 ROWAN-ROBINSON, L. C.: Prevention of venereal disease, 404
 ROWBOTHAM, Mr.: Anaesthetics in plastic surgery, 344
 ROWCROFT, Colonel G. F.: Hygiene of seamen, 842
 ROWDEN, Dr.: Post-operative x rays in breast cancer, 814
 ROWLETTE, R. J.: Medical reform in Ireland, 344
 ROWNTREE, Cecil: X-ray radiation and cancer, 440
 Royal Air Force. See Air
 Royal Army Medical Corps. See Army, British
 Royal Faculty of Physicians and Surgeons of Glasgow: Admission of Fellows, 446, 918
 Royal Medical Benevolent Fund. See Fund
 Royal Naval Dental Service. See Navy, Royal
 Rupee exchange, 586
 Rupture. See Hernia
 RUSS, S. (and others): Action of radium and x rays on tumour growth, 229
 RUSSELL, Douglas: Treatment of gastric and duodenal ulcers, 123
 RUSSELL, Lieut.-Col. Edgar Beer, obituary notice of, 548
 RUSSELL, William: *The Sphygmometer: Its Value in Practical Medicine*, rev., 386
 Russia: British aid for men of letters and science in, 65, 250—Census, reduction of the population, 585—Plague in, 708
 RUTHERFORD, Major Richard, obituary notice of, 253
 RYALL, Charles, knighthood conferred upon, 58, 61—Dinner to, 325
 RYAN, Thomas, presentation to, 253
 "Rycott" draining rack, 781
 RYFFEL, J. H.: Chemical estimation of gastric function, 383
 RYLAND, Archer: Case of pharyngeal pouch, 565
 RYLE, J. A.: Spirochaetosis icterohaemorrhagica, 205—Chemical estimation of gastric function, 383

S.

- ST. GEORGE, George: Case of delayed arsenical poisoning, 192
 St. John of Jerusalem. Order of: Lord Stanmore to be secretary-general, 540
 Salerno, school of, review of books on, 231
 Salines, hypertonic, in the treatment of cholera (Sir Leonard Rogers), 673
 Salpingitis, tuberculous (J. H. Greenberg), 818
 Salvasan in malaria. See Malaria treatment
 Salvasan substitutes, Ministry of Health's amended notice, 178
 Salvasan and the Wassermann test, 582
 "Salvarsanized serum" in sleeping sickness, 777. See also Sleeping sickness
 Samuels medical scholarships. See University of Liverpool
 SAMSON, G. G.: *Every Man his own Builder*, rev., 858
 SAMWAYS, D. W.: Dilatation of the heart, 188. (O)—Cardiac peristalsis and mitral stenosis, 490. (O)—Pulmonary and aortic blood pressures, 688
 Sanatorium benefit: Transfer of (in Scotland), 135—Termination of (parliamentary note), 438—Leading article on, 678
 Sanatoriums for tuberculosis: Midhurst, report, 650—Ministry of Health's revised list, 959
 SAND, René: *Organisation Industrielle, Médicale Sociale, et Education Civique en Angleterre et aux Etats-Unis*, 748

- SANDIFORD, Irene (and Walter M. BOOTHBY): *Laboratory Manual of the Technique of Basal Metabolic Rate Determination*, rev., 567
- SANDIGSON, Hamilton M.: Angina pectoris with auricular fibrillation, 339. (O)
- Sanitary inspectors' examination results, 325
- SARBADHICARI, Suresh Prasad, obituary notice of, 878
- ave the Children Fund. See Fund
- SAVILL, Agnes: Cure of haemorrhoids without operation, 479
- SAWYER, Brigadier-General Charles E., to arrange hospital facilities for disabled service men in America, 890
- SCATTERTY, Lieut.-Colonel William, appointed Knight of Grace of the Order of St. John of Jerusalem, 253
- SCHAEFFER, J. Parsons: *The Nose, Paranasal Sinuses, Nasolacrimal Passage-ways, and Olfactory Organ in Man*, rev., 272
- SCHALL, W. E.: X-ray radiation and cancer, 320
- Schick reaction in diphtheria (Gladys Ward), 928. (O)
- SCHMIDEN, Victor (and Arthur TURNBULL): *The Course of Operative Surgery*, rev., 856
- School children: Medical treatment of in London, 30—Refraction work among. See Refraction
- School Hygiene Congress. See Congress
- School Medical Officers' Association. See Association
- School punishments (E. H. T. Nash), 312
- SCHUSTER, L. F.: British aid for Russian men of letters and science, 250
- SCHWAB, Sidney I.: *The War Neuroses as a Physiologic Conservation*, 125
- Sciatica, chronic, surgical treatment of (J. Mill Renton) 557. (O)
- Sciatica treated by galvanic acupuncture (E. A. Goulden), 523. (O)
- Science of etiology (leading article), 534
- Science: What is science? 954
- Scientific medical literature, use and abuse of (W. Bulloch), 939
- Scientific papers: Preparation of (leading article), 612—Correspondence on, 720, 756, 795, 873, 913
- Scientific research in Germany, preservation of most important features of, 919
- Scotland:**
- Aberdeen University war record, 401
- Association of School Medical Officers of Scotland, conference, 282
- Association of Surgeons of Great Britain and Ireland, 718
- Bellahouston Hospital, 872
- Blind, Welfare of, Advisory Committee, 657, 953—Scottish Board of Health circular, 953
- Cameron Prize, 477
- Carnegie Universities Trust, 318
- Central Midwives Board, 209
- Consultative Council's medical service scheme, 208
- Cultivation of medicinal plants in, 960
- Dundee Royal Infirmary, 401
- East of Scotland Overseas Medical Club, 318
- EDINBURGH:
- Clinical meeting of Edinburgh Branch, 439
- Gynaecology at the Royal Infirmary, 580
- Maternity and child welfare, 508
- Orthopaedic teaching in, 135
- Royal Hospital for Sick Children, 790
- Royal Infirmary, 62, 242, 580
- Royal Edinburgh Mental Hospital, 400
- Students' fees, 684
- Students in Paris, 400
- Tuberculosis scheme, 507
- Tuberculosis Trust, 477
- University chemical laboratories, 318
- University Court, 953
- University Roll of honour, 790
- Women's Hospital and Hospice, 719
- Ferguson chemical library, 621
- Gibson, G. H. R., appointed Deputy Commissioner of General Board of Control in Scotland, 135
- GLASGOW:
- Bogus doctor in, 684
- Cancer Hospital, 507
- Ear, Nose, and Throat Hospital, 912
- Maternity Hospital, 362
- Overcrowding of medical students in, 242
- Post-graduate medical teaching, 507, 657
- Royal Asylum, 318
- Royal Infirmary, 282
- Small-pox, last case, 542
- Students' fees, 621
- University bequests to, 684
- Greig, D. M., of Dundee, presentation to, 62
- Highlands and Islands Medical Service, 30
- Housing in Scotland, 580
- Limbless men, care of (Princess Louise Cottage Hospital, Erskine), 242
- Maternity and child welfare, 508
- Meat inspection, 507
- Medical adviser to prison commissioners, 912
- Parliamentary representation of Scottish universities, 953
- Registrar-General for Scotland, the new, 136
- Royal Medical Society, 362
- St. Andrews University, 283
- School Medical Officers' Conference, 550
- Scottish Board of Health, 477, 657, 953
- Scotland (continued):**
- Scottish Consultative Council's medical service scheme, 208
- Scottish Regional Hospitals Committee, 208
- Vital statistics for 1920 541
- War lessons in civil life, 62
- Scotometer, a direct record, 645
- SCOTT, Gladys M. (and others): Action of radium and x rays on tumour growth, 229
- SCOTT, Major Herbert B., O.B.E. conferred upon, 917
- SCOTT, S. Gilbert: X-ray radiations and cancer, 509—Dual radio-therapy in malignant disease, 771. (O)
- SCOTT, S. Noy: Collective opinion of the profession, 543
- Scottish Board of Health: Parliamentary note, 475—Appointments, 477—Report on meat inspection in Scotland, 507
- Estimates, 575—Advisory Committee on the Welfare of the Blind, 657, 953—Compulsory notification of chicken-pox, 661
- Scottish Consultative Council. See Consultative
- Scottish Regional Hospitals Committee, 208. See also Association, British Hospitals
- Scottish Universities Bill, 715, 829, 951
- Scurvy in a breast-fed infant 583
- Scurvy, review of books on, 85
- Seamen, hygiene of, 538, 842—Venereal disease among (parliamentary note), 683
- Sea-sickness, smelling salts as a preventive, 726
- Sea water for internal use 369, 447
- SERILEAT, P.: (ataclysimal haemorrhage after tonsillectomy), 397
- Secret remedies and the German medical press 649
- Self-inflicted injuries. See Injuries
- Self notification. See Notification
- SELLARDS, A. W. (and others): *Typhus Fever, with Particular Reference to the Serbian Epidemic*, rev., 857
- SELLERS, Arthur (and E. N. RAMSBOTTOM): Complement fixation tests in the diagnosis of tuberculous infections, 47
- SELLORS, T. B.: Site of operation for empyema, 836
- Sell's World's Press*, rev., 232
- Semilunar cartilage, needle in, 108
- SEMON, Sir Felix, obituary notice of, 404
- Senescence and balneotherapy, 193
- Sepsis, mouth, need for post-graduate instruction in, 812, 920, 960
- Septicaemia in childbirth, prize for discovery of cause of, 447
- Septicaemia, cryptogenetic pneumococcal (Sir John Lumsden), 890. (O)
- Serbia, Typhus Fever in*, rev., 857
- Serbian girls, medical scholarships for, 359
- SERGEANT Emile (and others): *Traite de Pathologie Medicale et de Therapeutique Appliquee*, rev., 306, 897
- Serum, antigenococcal, use of (Frances Ivens), 77. (O)
- Serum diagnosis of syphilis. See Syphilis
- Serum treatment, review of book on, 897
- Serums, standardization of (parliamentary note), 399
- Service candidates, 682
- SEWELL, Lindley: Medical treatment of adenoids, 285
- Sex, review of books on, 51, 86
- SHANNON, David: Pelvimetry in contracted pelvis, 160—Caesarean section, 604
- SHARPE, William: *Diagnosis and Treatment of Brain Injuries*, rev., 345
- SHATTOCK, S. G.: Transfusion of the body, 581
- SHATTOCK, G. C. (and others): *Typhus Fever, with Particular Reference to the Serbian Epidemic*, rev., 857
- Shaving brushea and anthrax. See Anthrax
- SHAW, A. F. Bernard: "Minute bodies" in epidemic encephalitis, 210—The pathological museum at the annual meeting, 957
- SHAW, Batty: Albuminuria and life assurance, 83
- SHAW, Lawrence Drew, obituary notice of, 573
- SHAW-MACKENZIE, J. A.: Search for a specific treatment of tuberculosis, 402
- SHEA, John Goodwin, obituary notice of, 917
- SHEEN, A. W.: On the end-results of colectomies for intestinal stasis, 116. (O)
- Shetland: Edinburgh University Club dinner, 317—Joint medical meeting at, 541—Physiology and clinical medicine in (leading article), 646—Correspondence on, 688
- SHERA, A. Geoffrey: Differential staining of carcinomata, 639, 722, 796
- SHERRINGTON, C. S., dinner to, 436—Elected a member of the Atheneum Club, 761
- SHETLE, Major Francis B., O.B.E. conferred upon, 917
- Shin, pains in, 550
- Ship's surgeons, 369
- Shock, surgical, review of book on, 385
- SHORT, A. Rendle (and Cyril H. WALKER): Self-inflicted injuries in civilian practice, 238. (O)
- Shoulder, drooping, sign in phthisis (W. C. Rivers), 120 (O). See also Tuberculosis
- Siberia, plague in, 708
- SICARD, J. A.: Epidemic hicough, 28
- SICHEL, Gerald: The Naval Medical Service, 285
- Signs and symptoms, 369, 795
- Silicosis and tuberculosis among miners, 26
- SIMPSON, Alexander, appointed Deputy-Lieutenant for Lancashire, 833
- SIMPSON, John William, obituary notice of, 144
- SIMPSON, W. J. R.: Treatment of trypanosomiasis, 777
- Simulium reptans* in Ireland, 550
- SINCLAIR, Major Maurice: Treatment of fractures, 229—Fractures of femur, 229
- SINCLAIR, Colonel Thomas, elected to Senate of North Ireland Parliament, 907
- SINGER, Charles: *Studies in the History and Method of Science*, 822—What is science? 954
- SINGER, Kurt: *Leitfaden der Neurologischen Diagnostik*, rev., 818
- SINTON, Major John Alexander: Elected an honorary Fellow of the Ulster Medical Society, 30—O.B.E. conferred upon, 917
- SKERRETT, F. B.: Supernumerary nipples, 254
- SKILLERN, R. H.: *The Catarrhal and Suppurative Diseases of the Accessory Sinuses of the Nose*, rev., 463
- Skin of a white or coloured person? 796
- Skin disease, its relation to internal disorder. discussion on at Medical Society of London, 303
- See also Dermatology
- SKINNER, Captain George Arthur, Belgian Ordre de la Couronne conferred upon, 253
- Skull, effect of gunshot wound on, 628, 692
- SLATER, B. Holroyd: Bradford Municipal (General Hospital), 171, 245
- Sleeping sickness, review of books on, 85
- Sleeping sickness treatment: Report on (Claude H. Marshall and S. M. Vassallo), 773 (O)
- Discussion on, 777—Correspondence on, 916. See also Trypanosomiasis
- "Sleepy Dublin", 180
- SLEISINGER, E. G.: Fracture of the first rib, 284—Two unusual cases of abdominal tuberculosis, 703. (O)
- Small-pox, abolition of (W. McConnel Wanklyn), 317
- Small-pox: In Chicago, 468—In Bristol, 473—In (Glasgow, the last case, 542—Revaccination for (parliamentary note), 683—Aud vaccination (parliamentary note), 716
- SMALLWOOD, R. P.: Spina bifida, 480
- Smelling salts in prevention of sea-sickness, 726
- SMITH, J. C. Charneck: "Ethanosal" or "ether," 622
- SMITH, Elliot: Medicine of ancient Egypt, 472
- SMITH, F. W.: Various types of squill poison, 253
- SMITH, J. W.: Presents a medical institute to Newcastle, 279—Appointed a deputy-lieutenant for Lancashire, 833
- SMITH, Laphorn: Instrumental abortion, 461
- SMITH, Captain Robert Wilkie: Belgian Croix Civique conferred upon, 215
- SMITH, S. Alwyn: Treatment of fractures, 483. (O)
- SMITH, Captain William Adams, French Palmes Academique conferred upon, 515
- Smoke abatement and the equipment of dwellings, 60
- SMYTH, Johnson: One way of selecting a health resort, 70
- Societe Belge de Neurologie et de Psychiatrie, twenty-fifth anniversary of, 856
- Societe Bruxelloise de Laryngologie formed at Brussels, 51
- Societies, Compoint Board of Scientific, to discontinue publication of annual calendar and fortnightly bulletin of scientific meetings, 627—Report, 933
- Society, American Gynecological: *Transactions*, vol. xlv, rev., 644
- Society, American Pediatric: *Transactions*, vol. xxxii, rev., 645
- Society of Anaesthetists, Scottish: Post-operative morbidity in relation to general anaesthesia, 194—Post-anaesthetic vomiting, 194
- Society of Arts: Some effects of the war on industrial ureast, 825
- Society, Assurance Medical: Albuminuria in relation to life assurance, 83—Discussion, 83
- Society, Birmingham Medico-Psychological: Programme, 69
- Society, Brighton and Sussex Medico-Chirurgical: Types of glycosuria and their treatment, 345
- Society, Brooklyn Cardiological: First meeting, 215
- Election of President, 215—Honorary (British) members, 215
- Society of Chemical Industry: The new chemical industry, 133
- Society, Devon and Exeter Medico-Chirurgical: Practical gains in clinical cardiology, 12, 49
- Society, Edinburgh Medico-Chirurgical: Epididymitis and orchitis from muscular strain followed by tuberculosis of the epididymis, 293—Vaccine therapy in general practice, 194—Treatment by x rays and radium, 304—Treatment of stammering, 384—Cervical ribs and pressure symptoms, 384—Cardiospasm, 705—Mesenteric lymphadenitis simulating appendicitis, 706—Surgery of nasal deformities, 896—Treatment of fractures of the upper extremity, 896—Keratoderma blenorrhagica, 896
- Society, Edinburgh Obstetrical: Pregnancy and labour in a double uterus, 16—Obstetric practice amongst the Akikuyu tribe of Kenya Colony, British East Africa, 16

- Pelvimetry as an index of treatment in contracted pelvis, 160—Double congenital hydrocephalus, 160—*Transactions*, rev., 137—Discussion on "Twilight sleep," 341—Treatment of uterine prolapse, 496—Hæmorrhage with eclampsia, 496—Placenta prævia with post-partum eclampsia, 496—Organism cultivated from carcinoma, 933
- Society, French Orthopædic, next meeting, 834
- Society of German Laryngologists, 627
- Society, German Urological, next meeting, 593
- Society, Glasgow Obstetrical: Alteration of presentation and positions in labour, 603—Caesarean section, 604
- Society, Glasgow Royal Medico-Chirurgical: Treatment of gastric and duodenal ulcer, 121—Hæmochromatosis and bronzed diabetes, 461—Digestion of the oesophagus as a cause of post-operative and other forms of hæmsternis, 563—Surgical treatment of ecstasia, 564—Thoracic duct wounded in operation for removal of tuberculous cervical glands, 564—Caesarean section, 641—Renal diabetes, 779—Double uterus, resection of, followed by full-time pregnancies, 779—Amenorrhœa following severe trauma, 779
- Society, Harrogate Medical: Annual oration (Sir Berkeley Moynihan): Gastric ulcer, 35
- Society, Harveian, of London: Annual meeting, 145—Discussion on the future of the Poor Law infirmaries, 200—Harveian Lecture: The thymus gland in everyday life, 481—Nævi in children, 605
- Society, Hydrophobia Prevention: Annual meeting, 295
- Society, Illuminating Engineering: Artificial lighting for cinematography, 234—Sport by artificial light, 867
- Society, Industrial Welfare, note on, 627
- Society for Study of Inebriety: Use of alcohol in medicine, 608
- Society, London and Counties Medical Protection: Annual meeting and report, 576
- Society, Manchester Medical: Some aspects of preventive medicine, 642
- Society, Manchester Pathological: Vitamins, 779
- Society, Medical, of London: Skin disease, its relation to internal disorder, 303—Chemical estimation of gastric function, 383—148th anniversary dinner, 397—The non-operative treatment of surgical tuberculosis, 424—*Transactions*, vol. xliii, rev., 644
- Society, Medical, of Victoria: General meeting, 129—Election of life members, 129
- Society, Medical Golfing, 959
- Society of Medical Officers of Health: Relation of the laboratory to preventive medicine, 523—Election of President, 795—Honorary Fellowship, 795
- Society, North of England Obstetrical and Gynaecological: Annual meeting, 195—Exhibition of cases, 195, 385
- Society, Nottingham Medico-Chirurgical: Joint meeting with Midland Branch of the British Medical Association, 229—Fractures of the femur, 229—Radium therapy, 270
- Society, Ophthalmological, of the United Kingdom: Congress, 368, 712—*Transactions*, vol. xl, rev., 568
- Society, Ophthalmological, of Vienna: Next meeting, 834
- Society of Public Analysts: Squill rat poison, 253—Action of water on lead, 558—Composition of so called egg powders, 919
- Society, Red Cross, British (and Order of St. John): Report on home service ambulances, 237—War medal, 240—War finance, 315
- Society for Relief of Widows and Orphans of Medical Men: Annual meeting, 784—Report, 784
- Society, Research Defence, note on, 572
- Society, Röntgen: Silvanus Thompson Memorial Lecture, 616
- Society, Royal: Local and generalized action of radium and x rays upon tumour growth, 229—Election of Fellows, 357—The Retarded cinema, studies of movement, 287, 359—Election of foreign members, 725—Conversazione, 748
- Society, Royal, of Arts: Immunity and industrial disease, 827
- Society, Royal Medical: Annual dinner, 362
- Society, Royal Medical Benevolent Fund of Ireland: Annual meeting, 953
- SOCIETY, ROYAL, OF MEDICINE:
Combined meeting with National Veterinary Association: Some diseases of animals communicable to man, 351—Eradication of tuberculosis in man and animals, 421
Gibson Research Scholarship awarded, 918
Discussion on the private clinic system in Great Britain, 937
Meeting re increase of subscription, 661, 949
Prize for discovery of causes and prevention of death in childbirth from septicæmia, 447—Gold medal awarded, 950
Section of *Anæsthetics*.—Anæsthetics in the plastic surgery of the face and jaws, 344—Examination before anaesthetization, 528—Explosion of ether vapour during laryngoscopy, 528—A new anaesthetic, "ethæsal," 565
- SOCIETY, ROYAL, OF MEDICINE (continued):
Section of *Balneology and Climatology*.—Senescence in general and from the balneo-therapist's point of view, 193
Section for *Study of Children's Diseases*.—Congenital syphilis, 342, 460
Clinical Section.—Combined meeting with Sections of Medicine and Surgery: Discussion on exophthalmic goitre, 268, 342, 425
Section of *Epidemiology and State Medicine*.—Plague on shipboard, 640
Section of *the History of Medicine*.—The medicine of ancient Egypt, 972
Section of *Laryngology*.—Pharyngeal pouch, 565—Summer meeting, 855—Indications for and against complete tonsillectomy, 855—Frontal sinus operations, 855—Unusual site of origin of intrinsic cancer of larynx, 855—Paralysis of vocal cords in cases of malignant tumours of mamma, 855
Diathermy in inoperable growths, 855—Sacculus laryngis, 855—Vocal cord paralysis in horses treated by stripping Morgagni's ventricle, 855—Bronchoscopy in treatment of asthma, 855—Demonstrations, 855—Representative laryngologists place a wreath on Sir Morell Mackenzie's grave at Warrgrave, 855
Section of *Medicine*.—Artificial pneumothorax, 814
Sections of *Neurology and Ophthalmology*.—Discussion on ocular palsies, 426
Section of *Obstetrics and Gynaecology*.—Treatment of inoperable uterine carcinoma, 159—Morphine in labour, 159—Puerperal salpingo-peritonitis, 495—Study of the condition of the arteries in uterus removed twenty-four hours after delivery, 496—Causes, prognosis, and treatment of stiltity, 814
Subsection of *Orthopaedics*.—Habitual dislocations, 383
Subsection of *Proctology*.—Discussion on pruritus ani, 602
Section of *Surgery*.—Cardiac massage, 856
Section of *Tropical Diseases and Parasitology*.—The future of research in tropical medicine, 388—Hypertonic salines in the treatment of cholera, 673—Ankylostomiasis campaign in Egypt, 674
Section of *Tuberculosis and Pharmacology*.—Treatment of leprosy and tuberculosis with sodium synocardate, 640—Kaolin in the treatment of cholera, 640
War Section.—Influenza epidemic in the Navy, 705
- Society, Royal Photographic: Exhibition of x-ray photographs, 879
- Society, Royal, of Tropical Medicine and Hygiene: New method of treatment of trypanosomiasis, 773—Discussion, 777
- Society, Sheffield Medico-Chirurgical: Palliative treatment of aneurysms by wiring, 427—Joint meeting with British Medical Association, 541—Commission to Far East for inquiries re control of venereal disease, 541
- Society, South-Western Ophthalmological: Cases, 506—Some quaint problems, 506
- Society of Surgery, German, 482
- Society, Surgical Aid, presentation to the late treasurer and chairman, 368
- Society, Ulster Medical: Meetings, cases, papers, 30—Honour to Major J. A. Sinton, V.C., 30—Visit of Sir George Makins, 209—Acidæmia, 319—Annual dinner, 319—Case of deformity in a young child, 497—Examination of the meatology of patients in a general hospital, 497—Surgery of bones and joints, 497—Annual meeting, 834
- Society, Venereal Disease Prevention: Medical members of Executive Committee, 69—Annual meeting, 862. See also Venereal
- Society, Vienna Medical: Honorary members, 627
- Society, West London Medico-Chirurgical: Pathological meeting, 161—Clinical meeting, 270—Instrumental abortion, 461—Diagnosis and treatment of colitis, 525—Cases, 525—Annual dinner, 879—Pathological changes in breast epithelium, 895
- Sodium bicarbonate in treatment of sprue, massive doses of (Aldo Castellani), 338. (O)
- Sodium synocardate in treatment of leprosy and tuberculosis (Sir Leonard Rogers), 640
- Soldiers at Cologne, health of (parliamentary note), 438
- Soloid neutral red, 127
- SOLOMONS, Hethel: "Vicarious menstruation," 85—Fibrous and muscular attachments of the vagina, 778
- SOMERS, Arthur: Herpes zoster and varicella, 842
- SOUTHAM, A. H. (and C. H. CRAWSHAW): Resection of intestine for acute intussusception: two cases of recovery, 266. (O)—Treatment of acute pyogenic infection of knee-joint, 884. (O)
- Southend doctors' cricket club, 448
- SOUTTAR, H. (and E. W. TWINING): *Injuries of the Peripheral Nerves*, rev., 530
- SOYER, Alexis, 503, 586
- SPÄHLINGER, Henri: Specific treatment of tuberculosis, 307—Parliamentary note on, 360, 683
- Spain: Antimalaria campaign in, 165—Institute of biology named after Ramon y Cajal established in Madrid, 253—*Revista Médica de Hamburgo* founded, 691
- Spelling of chemical terms, 539
- SPENCER, Herbert: Appreciation of R. J. Bliss Howard, 105—Sterility, 815—Operative treatment of genital prolapse, 893
- Sphygmometer, review of books on, 386
- SPINNEY, Bernard H.: Instrumental abortion, 461
- Spina bifida, 480. See also Myelocèle
- Spirochaetosis icterohaemorrhagica, 206
- SPITTA, Edmund J., obituary notice of, 251
- Splenectomy in pernicious anaemia (leading article), 470
- Splenic anaemia, Banti's disease (Sir Berkeley Moynihan), 114. (O)
- Sport by artificial light, 867
- SPRIGGE, S. Squire: Knighthood conferred upon, 58, 61
- Sprue treated by massive doses of sodium bicarbonate (Aldo Castellani), 338. (O)
- SPRUNT, T. P.: Infectious mononucleosis, 95
- Squill rat poison, 253
- STAFFORD, Sir Thomas Joseph, elected to Senate of South Ireland Parliament, 907
- Stag's antlers. See Antlers
- STALLYBRASS, Captain T. W., Order of the Nile conferred upon, 690
- Stammering: Treatment of (Hamilton G. Langwill), 384—Discussion, 384
- STAMMERS, A. D.: Fat-soluble "A" content of oils, 104
- STARKE, A. Campbell: Glandular fever, 142
- STARKE, J. Nigel: Caesarean section, 604
- Stasis and cancer prevention, 31
- State contributions to health services (parliamentary note), 475
- State and disease prevention (Christopher Addison), 940
- STEDMAN, Thomas Lathrop: *A Practical Medical Dictionary*, rev., 781
- STEELE, Russell V.: Military medical history, 323
- STEEN, R. H.: Elementary psychology in general hospital teaching, 793
- STEINACH, E., invited to the University of Stockholm, 419
- Stenosis at the internal meatus after prostatectomy (Andrew Fullerton), 301. (O)
- Stenson's duct, operation for the radical cure of premassecteric fistulae of (Gilbert Chubb), 45. (O)
- STEPHENS, G. Arthur: The study of heart disease, 143—Portable manometer for intrapericardial pressure, 465—Heart-block, 877
- STEPHENS, J. R. W.: Penis captivus, 662
- Sterility, causes, prognosis, and treatment of (Arthur Giles), 814—Discussion, 815
- Stethoscope in France, 516
- STEVENS, Francis J., retirement of, 919
- STEVENS, T. G.: Operative treatment of genital prolapse, 893
- STEVENSON, C. M.: Prevention of puerperal infection, 757
- STEWART, P. J.: Acute infective arthritis, 727. (O)
- STEWART, Jéant.-Col. Sir Edward, Belgian Ordre de la Couronne conferred upon, 515
- STEWART, George C.: John Evelyn and medicine, 623
- STEWART, Sir James Purves: Muscle tonus, tonic rigidity, and tonic fits, 217. (O)—Appreciation of Peter Thomas Duncan, 583
- STEWART, Laurence T.: Digestion of oesophagus, 563
- STEWART, Professor: Leucocytic changes in Hodgkin's disease, 813
- STEWART, R.: Prevention of intestinal obstruction after ventrofixation, 639
- "Stibien," 650
- STRIDON, C. A.: Outfit for immediate treatment of cases of poisoning, 232—An anaesthetist's screen, 743
- STILES, Sir Harold: Treatment by x rays and radium, 304
- STOCKMAN, Ralph: Treatment of gastric and duodenal ulcers, 121
- Stock-taking, an annual (leading article), 824
- STODART, Colonel Thomas, C.I.E. conferred upon, 917
- Stomach, hour-glass (C. Thurstan Holland), 6. (O)—Correspondence on, 99
- Stomach plaster models of x-ray observations upon, 325
- STONE, Florence: Exophthalmic goitre, 342
- STONE, R. Atkinson: Modern surgery of the elbow, 48, 180
- STOOKY, Alexander, dinner and presentation to, 506
- STRACHAN, F. J.: Abdominal tumour following injury to thorax, 158
- STRANGE, Captain Charles F., French Médailles des Epidémies conferred upon, 515
- Street accidents in London, 621
- Streptococci and pneumococci, relation of to influenza (W. R. Logan), 189. (O)
- STRETTON, J. Lionel: Carcinoma of the large intestine, 555. (O)
- STRONG, R. F. (and others): *Typhus Fever, with Particular Reference to the Serbian Epidemic*, rev., 857
- STROUD, Captain E.: *The Use of Light as an Aid to Publicity, Shop Window, and Spectacular Lighting*, 711
- STRUTHERS, J. W.: Mesenteric lymphadenitis simulating appendicitis, 706
- Students in German universities, 51
- STURGE, Henry H.: Prevention of venereal disease, 443

- STURGE, Mary D.: Prevention of venereal disease, 139
- STROROCK, A. Corsar (and others): Residual vaccines, 846. (O)
- Subassistant Surgeons' Conference, 136
- Suicide and the Workmen's Compensation Act, 34
- Suresh Prasad SARBADEKARI, obituary notice of, 878
- Surgarias, "lock-up" (parliamentary note), 753
- Surgery, old work on by Johannes Tsgantius, 880
- Surgery, reviews of books on, 16, 85, 429, 642, 856
- Surgery of the right iliac fossa (J. E. Adams), 674
- Surgery, a survey of (Sir Berkeley Moynihan), 506
- Surgical instruments, proposed increase in tariff on: Protest against at New York Hospital Conference, 809
- Surplus medical stores. *See* Medical
- SURVEYOR, Nuservanji Fakirji, obituary notice of, 368
- Sussex provident scheme, 129, 132
- SUTHERLAND, Halliday: The production of symptoms, 210—A new sign in pulmonary tuberculosis, 285—Eradication of tuberculosis, 423—Bibliographical references, 479
- SUTHERLAND, J. N. M.: Refraction work in children, 91
- Sutherland, William: *A Biography*, rev., 430
- SWAN, W. A. M.: Angio-neurotic oedema treated by injections of horse serum, 68
- SWAYNE, Walter: Operative treatment of genital prolapse, 894
- Sweden: New pharmacopoeia, 661
- Swedish Government allots 5,000 crowns to Swedish Medical Association to help in the printing of its three scientific journals, 546
- SYME, Mr.: Bronchoscopy in treatment of asthma, 855
- SYMONDS, Sir Charters:—Hunterian Oration: Ayley Cooper and Hunterian principles, 274
- Pruritus ani, 602
- SYMONS, Brigade Surgeon John Trehane May, obituary notice of, 584
- Symptom, what is a? 210, 243, 283
- Symptoms of disease. *See* Disease
- Symptoms, production of, 210.
- Symptoms, review of book on, 605
- Symptoms and signs, 369
- Syphilis, antiquity of, 216, 704
- Syphilis, congenital, discussion on at Royal Society of Medicine, 342, 460
- Syphilis, formol-ster reaction in, 854
- Syphilis in Macedonia, treatment of (Trevor Hayman Fowler), 930. (O)
- Syphilis, review of books on, 196, 231, 429, 566, 857. *See also* Venereal.
- Syphilis, serum diagnosis of, 859, 950
- Syphilis, treatment of (Henry MacCormac and E. L. Kennaway), 415. (O)
- Syringe for treatment of the posterior urethra, 708
- SZLAPKA: Splenectomy in pernicious anaemia, 470
- T.
- Tall talisman, 448
- Tapeworm, 118, 180
- TAPLIN, Julian: Climate of the Riviera, 586
- Tartar emetic for venereal granuloma (W. E. Giblin), 932
- Tata professorships, 35
- TAYLOR, Arthur Snayd, obituary notice of, 839
- TAYLOR, James: Epilepsy considered as a symptom, not a disease, 4. (O)
- TAYLOR, J. A.: Lingual application of iodine as a prophylactic in cerebro-spinal meningitis and influenza, 776. (O)
- TAYLOR, John Richard, prosecuted under the Medical Act, 724
- TAYLOR, Captain J. S.: Alexis Soyer, 503
- "T.B. Officer," 370
- TEACHER, J. H.: Digestion of oesophagus, 563
- TEAGUE, William Koper, estate and bequests of, 250
- Teapot stirrer, 36
- Teeth, influence of diet on, 385
- TEICHMAN, Captain O.: *The Diary of a Yeomanry M.O. (Egypt, Gallipoli, Palestine, and Italy)*, rev., 838
- TEISSIER (and others, editors): *Nouveau Traité de Médecine*, rev., 195
- Telephone exchange, the Langham, 398
- Telephone exchanges for physicians in America, 860
- TELLING, W. H. Maxwell: Glandular fever, 509
- Tell-tale treatment (Louis XI), 818, 826
- Temperature, relation of to cardiac irregularity (R. Macnair Wilson), 226. (O)
- TENNENT, James N.: Organization of school ophthalmic work, 877
- TENNENT, Robert: Exomphalos, or hernia into the umbilical cord, 263. (O)
- Tennis elbow, 146
- Terminological confusion, 628
- TERRIEN, F.: *Surgery of the Eye and its Adnexa*, rev., 707
- Testicular disease following trauma (Charles W. Cathcart), 193
- Testis, descent of, 687
- Testis, torsion of in an infant (W. Gifford Nash), 267
- Tetanus, case of (L. T. Challenor), 228
- Tetanus, severe, successfully treated by large doses of antitetanic serum (T. V. Carey), 121
- THAMMAH, Captain Sarevananathar, M.C. conferred upon, 917
- THAYER, William S., resignation of, 841
- Thermometers, clinical (parliamentary note), 438
- Therapeutic substances not amenable to chemical analysis, control of, 357
- Therapeutic tendencies (Charles Whitby), 466
- Thermometers, imported, untested, 253
- Thermostat, an electric, 586
- THOM, G.: Naevi in children, 726
- THOMAS, J. Lewis: Nasopharyngeal catarrh and tuberculosis, 285—Signs and symptoms, 369
- THOMPSON, Lloyd: *Syphilis*, rev., 429
- THOMSON, Alexis: Treatment by r rays and radium, 304—*Operative Surgery*, rev., 856
- THOMSON, Arthur J.: *Outlines of Zoology*, rev., 898
- THOMSON, H. Wright: Organization of school ophthalmic work, 915
- THOMSON, John: *The Clinical Study and Treatment of Sick Children*, rev., 565
- THOMSON, J. W.: Tumour of the neck, 192
- THOMSON, Lawrence Ramsay, obituary notice of, 761
- THOMSON, Sir St. Clair: Usual site of origin of cancer of larynx, 855, 921. (O)
- THOMSON, Torrance: Post-operative morbidity in relation to general anaesthesia, 194
- Thoracic duct wounded in operation for removal of tuberculous cervical glands (G. H. Edington), 564—(Archibald Young), 564
- THORBURN, Sir William: Resigns Chair of Clinical Surgery at Manchester University, 176—Diathermy for inoperable growths, 462
- Note on, 540—Posterior rhizotomy for the relief of pain, 629. (O)—Appointed a Deputy Lieutenant for Lancashire, 833
- THORNE, R. Thorne: Normal delivery after traumatic rupture of uterus, 459
- THORNTON, G. L.: "D.A.H.", 49
- THORNTON, G. O. (and W. F. Theodore HAVLAIN): Labour in a case of encephalitis lethargica, 382
- THORPE, Sir Edward: *Dictionary of Applied Chemistry*, rev., 464
- THRESH, J. C.: Action of water on lead, 558
- Throat and nose diseases, diathermy in (W. J. HARRISON), 220. (O)
- Throat and nose diseases, review of books on, 463
- THURFIELD, Hugh: Value of the Wassermann reaction, 719
- Thurteill and Hunt, *Trial of*, rev., 677
- Thyinus gland in everyday life (Leonard Williams), 481
- Tibet, scientific expedition to, 350
- TICHBURST, G. A.: A compact warm ether inhaler, 935
- TIDY, Henry Letheby: *A Synopsis of Medicine*, rev., 18—Glandular fever, 100—(and E. B. MORLEY): Glandular fever, 452. (O)
- TILLEY, Herbert: The risks after operations for tonsils and adenoids in outdoor clinics, 65
- Tinnitus aurium, 146, 254
- Tissues, true colour of, 216
- Titles of retired officers, 690
- TODD, A. H.: Habitual dislocations, 384
- TODD, Colonel Octavius, obituary notice of, 215
- TOMKINS, Harding H.: Improved mouth gag, 180
- TOMLIN, Captain Herbert, French Médaille de l'Épidémie conferred upon, 515
- Tonsillectomy, cataclysmal haemorrhage after, 397
- Tonsillectomy, complete, indications for and against (Mark Howell), 855, 916—Correspondence on, 916
- Tonsillitis, follicular, and diphtheria (W. H. Palmer), 527
- Tonsils and adenoid operations in outdoor clinics, risks after, 32, 65, 101, 140, 174, 213, 245, 285, 321, 404, 443—Leading article on, 167
- Toxaemia, acute, treatment of, 835, 953
- Toxaemia, review of book on, 780
- Toxins and nerve centres, 920
- Toxins, the path of to the nervous system (Martin Button), 853. (O)
- Trachoma amongst the school children of Marseilles, 702
- TRAIL, G. S., presentation to, 178
- Trainway accident claims, London County Council retains services of three medical men for examination of, 287
- Transfixion of the body, 550, 581
- Transmigrants, accommodation for, 202
- TRASK, J. D.: Transmission of measles to monkeys, 500, 936
- Trauma followed by testicular disease (Charles W. Cathcart), 193
- TRESILIAN, Fred.: Herpes and varicella, 340—Evolution in relation to disease, 721
- Trials, notable: The Wainwrights, 272—Thurteill and Hunt, 677—Burke and Hare, 745
- TRIDON, André: *Psycho-analysis and Dehydration*, rev., 531—*Psycho-analysis, its History, Theory, and Practice*, rev., 531
- TRIMBLE, C. J., appointed Deputy-Lieutenant for Lancashire, 833
- Trinitrotoluene poisoning (leading article), 395
- Trinitrotoluene poisoning, blood changes in, 179
- Triplets, 70
- Tropical Diseases Institute in Panama in memory of Surgeon-General Gorgas, 583
- Tropical diseases, parasitic, Rockefeller foundation representatives visit England to discuss extension of activities, 907
- Tropical diseases, pensions medical treatment for (parliamentary note), 576
- Tropical diseases prevention, committee for, 512—Correspondence on, 542
- Tropical diseases, review of books on, 196, 606
- Tropical Medicine, American Journal of*, 661
- Tropical Medicine, Calcutta School of, 97, 574
- Tropical medicine, future of research in (Sir Leonard Rogers), 388—Correspondence on, 512, 542, 834—Facilities in Mauritius, 834
- Tropical Medicine, London School of: Appointments, 585—Pass lists, 68, 626—Filaria expedition to British Guiana, 280—Lord Milner's Fund for, 360—Laugley Prize in, 828
- TRUMAN, Claude A. P.: Angio-neurotic oedema, 102, 545
- Truss fitting, 516
- Trypanosomiasis, intermissions in, 916
- Trypanosomiasis research, report of Departmental Committee, 434
- Trypanosomiasis treatment (Claude H. Marshall and S. M. Vassallo), 773. (O)—Discussion, 777—Correspondence on, 916
- TUBBY, A. H.: *A Consulting Surgeon in the Near East*, rev., 230
- Tuberculin administration, tray for, 273
- Tuberculin in epilepsy (James Crockett), 458
- Tuberculosis in 1919, 202
- Tuberculosis, abdominal, two unusual cases of (E. G. Slesinger), 703. (O)
- Tuberculosis, acid-fast bacilli in relation to cure of, 879
- Tuberculosis administration, defects in, 839
- Tuberculosis Bill, 399, 470, 616, 652, 682, 753
- Tuberculosis, bovine, 544
- Tuberculosis in the Canadian Forces, 680
- Tuberculosis in children of school age (Jane Walker), 641
- Tuberculosis colony, Cumberland, 54
- Tuberculosis Conference, International, 241, 398, 872
- Tuberculosis death rate, the fall in, 322, 443
- Tuberculosis dispensary to be opened at Bordeaux in memory of American nurses who fell in the war, 919
- Tuberculosis, early diagnosis of, 216
- Tuberculosis, drooping shoulder sign in (W. C. Rivers), 120. (O), 441—Correspondence on, 216, 248, 285, 367, 441
- Tuberculosis, epidemiology of (leading article), 570
- Tuberculosis, glandular and pulmonary (W. Williams), 158—Correspondence on, 213
- Tuberculosis immunizing vaccine (Nathan Raw), 594. (O)
- Tuberculosis in man and animals, eradication of, discussion on, 421—Correspondence on, 550
- Tuberculosis mortality (parliamentary note), 399, 504—In Austria, 468—Correspondence on, 510—In Rio de Janeiro, 739—In Brazil, 739
- Tuberculosis and nasopharyngeal catarrh, 285
- Tuberculosis, predisposing cause in, 370
- Tuberculosis prevention, Canadian Association's report on, 107—Edinburgh schema, 507
- Tuberculosis Prevention, National Association for: Annual conference, 126
- Tuberculosis, pulmonary, a new sign in, 285
- Tuberculosis, pulmonary, calcium in treatment of (Edward E. Prest), 420
- Tuberculosis, pulmonary, statistics on the prevention of (Surgeon Commander D. H. C. Given), 225. (O)—Correspondence on, 285
- Tuberculosis regulations, 1921 (leading article), 678—Correspondence on, 839, 913
- Tuberculosis scheme, the Cheshire, a criticism of, 910
- Tuberculosis and silicosis among miners, 26
- Tuberculosis, sodium gynecardate in treatment of (Sir Leonard Rogers), 640
- Tuberculosis, Spahlinger treatment for, 307, 360, 402, 683
- Tuberculosis, specific treatment of: A bacteriologist's attempt (Spahlinger), 307—Correspondence on, 402
- Tuberculosis, surgical, non-operative treatment of, discussion at Medical Society of London, 424
- Tuberculosis treatment (parliamentary notes), 438, 576, 653, 829—Institutional, 506—Note on, 539—And county councils, 576
- Tuberculosis Trust, the Edinburgh, 477
- Tuberculosis, vaccination of cattle against (leading article), 130
- Tuberculosis ("virgin subjects"), 103
- Tuberculous adenitis. *See* Adenitis
- Tuberculous ex-service men (parliamentary note), 361
- Tuberculous haemarthrosis of knee (John A. C. Maccewen), 158
- Tuberculous infections, complement fixation tests in the diagnosis of (Arthur Sellers and E. N. Ramsbottom), 47
- Tuberculous milk. *See* Milk
- Tuberculous salpingitis (J. H. Greenberg), 818
- Tumour of abdomen following injury to thorax (F. J. Strachan), 158

Tumour of bladder among workers in aniline factories, 645
 Tumour growth, action of radium and α rays on (S. Russ, Helen Chambers, and Gladys M. Scott), 229
 Tumour of neck (J. W. Thomson), 192
 Tumours as malformations, 789
 Tumours of the parotid gland (Robert Kennon), 270
 TUNSTALL, A. C. (and F. J. WARWICK): *First Aid to the Injured and Sick*, rev., 568
 Turkestan, scientific expedition to, 350
 TURNBULL, Arthur (and Victor SCHMIDEN): *The Course of Operative Surgery*, rev., 856
 TURNER, E. B., reviews Sir Archibald Reid's book on venereal disease prevention, 162
 TURNER, J. G., reviews Karl Pearson and Julia Bell's book on the long bones of the human skeleton, 124
 TURNER, Logan: Paralysis of vocal cords in malignant tumours of the mamma, 855
 TURNER, Philip: Obstruction by a band in a large scrotal hernia, 738. (O)
 TURNER, Robert Shand, presentation to, 515
 TWEDDY, E. Hastings: Fibrous and muscular attachments of the vagina, 778
 "Twilight sleep" (F. W. N. Haultain), 341—A correction, 408
 TWining, E. W. (and H. SOUTTAR): *Injuries of the Peripheral Nerves*, rev., 530
 Twins, 796
 TYLER, John M.: *The New Stone Age in Northern Europe*, rev., 933
 Typhoid carriers (leading article), 786
 Typhoid vaccination statistics, 651
 TYRRELL, Edgar J.: Supernumerary nipples, 448
 TYTLER, Peter, obituary notice of, 689

U.

Ulcer, duodenal, perforation of, complicating acute retention of urine (G. A. Ewart), 420
 Ulcer, duodenal, treatment of (Ralph Stockman), 121—Discussion, 122
 Ulcer, gastric, dental caries and appendicitis, 960
 Ulcer, gastric, and gastric cancer, 99
 Ulcer, gastric, persistence of, after perforation, 613
 Ulcer, gastric, treatment of (Ralph Stockman), 121. Discussion, 122
 Ulcer, rodent, suggested autoinoculation of (S. C. Dyke), 932. (O)
 Ulster Parliament, the new, 656—Medical members in, 834—Senators appointed, 907
 Unemployment and sickness benefit. *See* Insurance
 UNITED STATES:
 American Medical Association: Annual meeting, 788
 American Orthopedic Association: Annual meeting, 899
 American University (leading article), 864
 Asthma clinic in New York, 215
 Automobile dispensaries for child welfare work, 944
 Brooklyn Cardiologist Society: First meeting, 215—Honorary (British) members, 215
 Chicago, small-pox in, 468
 Disabled service, hospital facilities for, 890
 Hospital ship being built at Philadelphia, 919
 Infant mortality in New York, 839
 Mayo Clinic, 681
 Medical students in 1919-20, number of, 547
 New York Radium Institute acquires 500 mg. of radium, 661
 Nurses who gave their lives in the war, memorials to, 725, 919, 937
 Panama memorial to Surgeon-General Gorgas, 583
 Population of, 725
 Rockefeller Foundation endows a training college for nurses at Brussels, 725
 Surgical instruments: protest against the proposed increase in tariff on, 809
 Telephones exchanges for physicians, 860
 Typhoid fever statistics, 713
 Venereal Disease Congress, 90
 Whisky and wine allowance to be drawn by Chicago druggists, 795

Universities and colleges, grants to (parliamentary note), 575, 654, 829—Estimates, 575—For Scotland and Wales, 654
 Universities of Germany, number of students, 51
 Universities, Scottish, Bill, 715, 829, 951—Parliamentary representation, 653
 University of Aberdeen: Degrees and pass lists, 514, 547—War record, 401
 University, the American (leading article), 864
 University of Belfast, Queen's: Representation of in the Ulster Parliament, 242, 656—Degrees and pass lists, 480
 University of Birmingham: Report of council, 252
 University of Bristol: An appeal, 647—Degrees and pass lists, 324—Dinner of the Medical School, 63—Future of, 579—Resignation of Vice-Chancellor, 840, 871—Wills bequest to, 253

UNIVERSITY OF CAMBRIDGE:
 Appointments, 616, 794, 917, 958
 Degrees and pass lists, 34, 176, 214, 324, 406, 480, 722, 761, 794, 878, 917, 958
 Diploma in medical radiology and electrology, 324; in psychological medicine, 514, 878; in hygiene, 956
 Examinations, 722, 917—Alterations of rules, 917
 John Lucas Walker studentship in pathology, 480
 M.Ch. degree, status of, 214
 Readership in experimental psychology, 214
 Women, admission of, 865

University constituents, 368
 University of Dublin: Degrees and pass lists, 547, 659
 University of Durham: *Calendar*, rev., 197—Degrees and pass lists, 514, 546

UNIVERSITY OF EDINBURGH:
 Appointments, 176, 794
 Cameron prize, 477
 Chemical laboratories, 318
 Degrees and pass lists, 514
 Delegates to Congress of Universities, 176
 Graduation ceremony, 514
 Orthopaedic teaching in, 135
 Physiology department, 546
 Resignations, 176, 794
 Roll of honour, 325, 790
 University Court, 953

University of Ghent: Chair of psychiatry to be created, 795
 University of Glasgow: Request to, 684—Degrees and pass lists, 547, 689, 761—Ferguson chemical library, 621—Frederick William Perrin memorial, 684—Honorary degrees, 761—Overcrowding of medical students, 242—Students' fees, 621
 University Grants Committee, report, 350
 University of Hamburg: Clinical research in pharmacology, 868
 University of Ireland, National: *Calendar*, rev., 197—Special meeting of Senate, 657
 University of Jerusalem, 674
 University, Johns Hopkins: Expedition to Porto Rico to study malaria, 919
 University of Leeds: Appointments, 506—Pathological department, 871
 University of Leyden: 346th anniversary of, 360
 University of Liverpool: Chair of obstetrics, 911—Degrees and pass lists, 514—Samuels medical scholarships, 368
 University of London: Sixteenth-century scheme for, 58

UNIVERSITY OF LONDON:
 Appointments, 68, 106, 252, 324, 407, 546, 918
 Beit Fellowships, 407
 Brown Animal Sanatory Institution, 918
Calendar, rev., 197
 Chair of anatomy at St. Bartholomew's, 106, 252
 Chair of embryology at University College, 252, 324
 Chair of obstetrics, London School of Medicine for Women, 324
 Chair of physics at Bedford College, 252
 Chair of physiology at Middlesex Hospital, 252
 Degrees and pass lists, 34, 368, 723, 840, 918
 Dental Research Fellowship, 546
 Diploma in psychological medicine, 106
 Dixon Fund, 252
 Election to Senate, 918
 Examination regulations, 407
 Examiners, 546, 918
 Graham Legacy Medical Research Committee report, 106, 324
 Guy's Hospital, 546
 Lectures, 68, 407, 723, 761, 786, 918, 958
 London Hospital, 176
 Matriculation results, 368
 Meeting of Senate, 106, 252, 324, 546, 723, 918
 Mental deficiency course, 546
 Parliamentary notes, 316
 Physiological laboratory, 131, 205, 278, 283, 314, 436, 480—At South Kensington, 314, 436, 480
 Presentation ceremony, 407, 723
 Prince of Wales, 324, 407, 723
 Professor of medicine, 546
 Professor of obstetrics, London School of Medicine for Women, 324
 Professor of surgery, 546
 Psychological medicine, examination regulations, 252
 Recognition of teachers, 106, 407
 Rogers prize, 252
 Senon lecturer, 918, 958
 Site of: Holland Park, 132, 275; Bloomsbury, 475, 504—(Parliamentary notes), 316, 475, 504
 Title of professor of pharmacology, 68
 University College, 761
 University medal, 106, 252
 William Julius Mickie Fellowship, 106

University of Manchester: Appointments, 176, 286, 287, 659, 723, 761, 918—Awards, 878—Degrees and pass lists, 34, 514, 723—Honorary degrees, 723—Resignations, 176—University prize, 176
 University of Manitoba: New buildings, 839

UNIVERSITY OF OXFORD:
 Appointments, 917
 Degree days, 446
 Degrees and pass lists, 34, 406, 917, 958
 Diploma in ophthalmology, 106
 Diploma in public health, 446, 722
 Election of members to the board of the Faculty of Medicine, 917
 Examiners, 917
 Lectures, 176
 Litchfield lecturer in medicina, 917
 Ophthalmology certificate, 214
 Osler memorial, 446
 Radcliffe prize, 480
 Radcliffe Travelling Fellowship (1921), 144, 480
 Rolleston memorial prize (1922), 722
 Scholarships in natural science, 176
 Wilde readership in mental philosophy, 722
 Woman demonstrator of anatomy's stipend, 214

University of Paris: Appointments, 304
 University of St. Andrews: Appointments, 68, 283—Degree and pass lists, 68—University court, 68
 University of Sheffield: Appointments, 794, 918—Degrees and pass lists, 252—Gift to, 794—Physiology and clinical medicine in, 648, 688—Vote of condolence, 794
 University of Sydney: Professorship of anatomy, 63—Chair of psychiatry, 684
 University of Wales, medical school of, 677
 University, Yale: Reconstruction plans, 841
 Unmarried mother. *See* Mother
 Unrest, epidemic of, 825
 Ureter, female, injuries to (A. Leyland Robinson), 665. (O)
 Urethra, posterior, syringe for treatment of, 708
 Urethral drainage bougie, 645
 Urethral stricture, retrograde catheterization for impermeable (W. J. Foster), 931. (O)
 Urethral stricture, treatment of (P. L. Giuseppe), 702 (O)—Correspondence on, 762
 Urine, acute, retention of, complicated by perforation of a duodenal ulcer (G. A. Ewart), 420. (O)
 Urine, chronic retention of due to prostatic disorder (Herbert T. Herring), 376. (O)—Correspondence on, 441, 544, 688, 692
 Urine retention due to haematocolpos and haematometra in a child (J. K. Haworth), 673
 Urology, review of books on, 230, 781
 Uterus, removed twenty-four days after delivery, condition of arterios in (Geoffrey Evans), 496
 Uterus, double, pregnancy and labour in (D. Robertson Dobie), 16
 Uterus, double, resection of followed by two full-term pregnancies (Munro Kerr), 779
 Uterus, haemorrhage of, not associated with pregnancy, treatment of (James Phillips), 224. (O)
 Uterus, pregnant and non-pregnant, action of quinine on in the tropics (Walter Fisher), 891
 Uterus, prolapse of (Samuel Cameron), 496
 Uterus, retroflexion of, operation for (John Craig), 639
 Uterus, ventrofixation of, prevention of intestinal obstruction after (Alexander Don), 563—(R. Stewart), 639
 Utrecht serological institute, rabies statistics, 784
 UTING, John, appointed Deputy Lieutenant for Lancashire, 833

V.

Vaccination, Jenner's first, 125th anniversary of, 840
 Vaccination: Parliamentary notes on, 61, 716, 951—And small-pox, 716—Deaths associated with, 951
 Vaccination certificate, prosecution for false return, 107
 Vaccination, typhoid, statistics, 651
 Vaccinators, Public, Association of: Annual meeting, 317—Annual dinner, 317
 Vaccinators, public, fees of, 171. *See also* Fees
 Vaccine therapy in general practice (R. Robertson), 194
 Vaccine therapy in regard to general practice (Alexander Fleming), 255. (O)—Correspondence on, 320
 Vaccine treatment, review of book on, 897
 Vaccine, tuberculosis immunizing (Nathan Raw), 594. (O)
 Vaccines, residual, new technique for preparation of (C. E. Jenkins, C. C. Heywood, A. Corsar Sturrock, and G. J. Langley), 846. (O)
 Vagina, cancer of. *See* Cancer
 Vagina, fibrous and muscular attachments of (Louis Cassidy), 778—Discussion, 778
 Vaginal operations, plastic, for genital prolapse (W. E. Fothergill and F. H. Lacey), 892
 Vagitus uterinus, 369
 VAN GEYZEL, Lieut.-Col. John Lawrence, C.I.E. conferred upon, 61
 VAN PRAAG, H. J.: "The Bull Book," 880
 VAQUEZ, H. (and E. BORDER): *Le Coeur et l'Arterie: Etudes de Radiologie Clinique*, rev., 499

- Varicella and herpes. *See* Herpes
 Varicocele, radical cure of (Sir John O'Connor), 738. (O)
 VASEY, S. Archibald, obituary notice of, 106
 VASSALLO, S. M. (and Claude H. MARSHALL): Report on the treatment of sleeping sickness, 775. (O)
 VAUGHAN, Lieut.-Col. J. C. S.: Preliminary note on the use of *Vitex peduncularis* in malarial fever and in blackwater fever, 186. (O)
 VECKL, V. G.: *Sexual Impotence*, rev., 51
 VEITCH, Alexander, obituary notice of, 513
 Venereal Disease Act, prosecution under, 795
 Venereal disease, arsenobenzol treatment of (parliamentary note), 753
 Venereal disease, Birth-rate Commission on, 314
 Venereal disease campaign: Commission sent out by the National Council for Combating Venereal Diseases arrives in Canada, 27—Conference at Copenhagen, 682, 749—Report of Commission, 716—In Derbyshire, 718—In India, 755
 Venereal disease, civil policy as to (parliamentary note), 475
 Venereal disease clinic, male, at the Royal Infirmary, Leicester (Major Henry J. Blakesley), 619
 Venereal disease clinics for London, 506
 Venereal Disease Commission: In the West Indies, 107—Leaves for England, 407—A note by one of the members, 541
 Venereal Disease Congress in America, 90
 Venereal Disease Conference, North European, 682, 749, 909, 957
 Venereal disease in Crown Colonies and seaports abroad, reports of commission, 716
 Venereal disease instruction course for medical women, 668
 Venereal disease: Prevention, 100, 139, 211, 245, 284, 323, 389, 404, 443, 476, 505, 684, 758, 861—Conference on, 339—Resolution by Mearns Fraser, 389—Policy of the National Council, 476—Propaganda to check the disease (parliamentary note), 505—Policy of the Government, 861
 Venereal disease prophylaxis, 32, 66, 100, 139
 Venereal disease report (parliamentary note), 399, 473—Discussion in the Lords, 473
 Venereal disease, review of books on, 161, 566
 Venereal disease on the Rhine (parliamentary note), 438, 475
 Venereal disease amongst seamen (parliamentary note) 683
 Venereal disease treatment, 686, 716—Parliamentary note, 716—In India, 755
 Venereal Diseases, National Council for Combating: Statement of relations with the Society for Prevention of Venereal Disease, 515—Annual meeting, 862
 Venereal granuloma, tartar emetic for (W. E. Giblin), 932
 Ventrifixation of uterus. *See* Uterus
 VERDON, Walter: *Angina Pectoris*, rev., 125
 VERNES, Arthur: *Atlas de Syphilimétrie*, rev., 857
 VERNON, H. M.: Fatigue and efficiency in the iron and steel industry, 131
 VICARS, Frederic: Alexis Boyer, 586
 VICKERY, D. H.: Supernumerary nipples, 288—Bullet in the cauda equina, 302
 Vienna: Post-graduate work in, 169, 683, 840
 Vital statistics: Leading article, 166—Registrar-General's report for 1919, 169—Quarterly return, 472, 656, 784—For England and Wales for 1920, 178—For Scotland for 1920, 541. *See also* Registrar-General
 Vitamin, pronunciation of, 828
 Vitamins (Gowland Hopkins), 237—(E. Mellanby), 779
 Vitamins and dental caries, 837
Vitex peduncularis in malaria and in blackwater fever (Lieut.-Col. J. C. S. Vaughan), 186. (O)
 VIVIAN, S. P., appointed Registrar-General, 135
 Vladivostok, plague in, 708
 Vocal cords, paralysis of in horsea treated by stripping of Morgagni's ventricle (Mr. Hobday), 855
 Vocal cords, paralysis of in malignant tumours of the mamma (Logan Turner), 855
 Voluntary principle and the Bradford bogey, 98. *See also* Hospitals, voluntary
 Vomiting, post-operativa (H. P. Fairlie), 194
- W.
- WADE, Henry: Influence of the war on the modern treatment of fractures, 327. (O)
 WALDEYER, Heinrich Wilhelm von, death of, 661
 WALDO, F. J., holds 599 inquests in 1920, 549
 Wales: Board of Health (parliamentary note), 909—National Memorial Association and tuberculous milk, 34—National School of Medicine, 677, 910
 WALFORD, Edward, resigns medical officership of city of Cardiff, 627
 WALFORD, Walter G.: Cement and CO₂, 448
 WALKER, Cranston: Adrenaline in resuscitation from apparent death, 46 (O), 100—A disclaimer, 100
 WALKER, Cyril H. (and A. Rendle SHORT): Self-inflicted injuries in civilian practice, 298. (O)
 WALKER, Captain Frederick Septimus, Belgian Croix Civique conferred upon, 215
 WALKER, Jane: Tuberculosis in children of school age, 641—Artificial pneumothorax, 814
 WALKER, J. W. Thomson: Part of the practitioner in the treatment of the pre-operative stage of enlarged prostate, 71. (O)—Correspondence on, 211
 WALKER, Kenneth M.: Prevention of venereal disease, 211—Sterility, 315
 WALKER, Norman: Treatment by X-rays and radium, 304
 WALKER, R. R.: Kaolin in treatment of cholera, 640
 WALKER, Samuel obituary notice of, 660
 WALKER, T.: *The Art of Attaining High Health, together with Aristology, or the Art of Dining*, rev., 858
 WALLACE, Major George S., O.B.E. conferred upon, 917
 WALLACE, J. Sim: Stae's antlers and evolution, 247—Alkaline dentifrices and the decrease of dental caries, 726—Vitamins and dental caries, 837
 WALLER, A. D.: Measurement of human emotions, 280—(and G. DE DECKER): Physiological cost of muscular work measured by the exhalation of carbon dioxide, 669. (O)
 WALLIS, R. L. Mackenzie: Chemical estimation of gastric function, 383—A disclaimer, 550—A new anaesthetic "ethanestal," 565
 WALTERS, James Hopkins, obituary notice of, 584
 WALTON, A. J.: Exophthalmic goitre, 342
 WANLYN, W. McConnel: Abolition of smallpox, 317
 War Emergency Fund. *See* Fund
 War enlistments and casualties: The gross figures analysed (parliamentary note), 715
 War lessons in civil work (Sir Henry M. W. Gray), 62, 109. (O)
 War, termination of (parliamentary note), 576
 WARD, E.: Asthma and anaphylaxis, 511
 WARD, Edward, obituary notice of, 723
 WARD, Gladys: The Schick reaction for diphtheria, 928. (O)
 WARD Gordon: The collective opinion of the profession, 322
 WARREN, A. A.: Eradication of tuberculosis in man and animals, 550
 WARNER, Allan: Risks after operations on tonsils and adenoids in outdoor clinics, 213
 Warning, 215, 324
 WARWICK, F. J. (and A. C. TUNSTALL): *First Aid to the Injured and Sick*, rev., 568
 Washington Labour Convention (parliamentary note), 829
 Wassermann reaction: Value of, 658, 686, 719—Mechanical apparatus for (Ernest Glynn), 641, 674
 Wassermann test, regulations for in Germany, 775
 Wassermann test and salvarsan, 582
 Water, action of on lead (I. C. Thresh), 558
 Water shortage due to drought, circular from Ministry of Health, 919
 WATSON, A. (and D. NOEL PATON): Etiology of rickets, 594. (O)
 WATSON, Eric R. (editor): *Trial of Thurtell and Hunt*, rev., 677
 WATSON, Gordon. *See* Gordon-Watson
 WATSON, Samuel, presentation to, 368
 WATSON-WILLIAMS, P.: Risks after operation in tonsils and adenoids in outdoor clinics, 140, 245
 WATT, J. Mitchell, appointed to chair of pharmacology at University College, Johannesburg, 691
 WATT, Thomas, obituary notice of, 794
 WATTS, A. M.: Incubation period of scarlet fever, 495
 Weather, changes of, and various aches, 482
 WEATHERHEAD, E.: "T.B. officer," 370
 WEBB, J. Curtis: Treatment of haemorrhoids by electrolysis, 457. (O)
 WEBER, F. Parkes: Albuminuria in relation to life assurance, 78. (O)
 WEBSTER, Wm.: The late Dr. Newton of Stoke-on-Trent, 512
- The Week:**
 Académie de Médecine centenary, 26
 "Aesthesiopsia abdominalis," 435
 Air ambulances, 434
 Alcoholism, treatment of, 750
 Alexander and Parke Memorial prizes, 96
 Alkaloids and glucosides, 59
 Ambulance plans, emergency, 616
 American Field Marshal (W. W. Keen), 279
 American Medical Association, 783
 Annual Meeting at Newcastle: Pathological Museum, 93—Programme, 535, 789—Revised arrangements, 679—Accommodation, 828
 Anthrax from shaving brushes, 207
 Apothecary poet (Keats), 905
 Army Dental Corps, 133
 Artificial limbs, 436
 Asthma clinic, 615
 Benvenuto Cellini's medical experiences, 651
 Bilharzia disease, 501
 Bilharziasis and its treatment, 650
 Birthday honours, 865
 Birth-rate Commission on venereal disease, 314
 Births marriages, and deaths, 472
- The Week (continued):**
 Blackwater fever, 94
 Bright, Richard, his less known contributions to medicine, 906
 Bright's disease, discoverer of, 573
 By-way of evolution, 857
 Calcutta School of Tropical Medicine, 574
 Cancer mortality, 312
 Cancer and the public, 472
 Cancer serum, 206
 Carbon monoxide, effects of on the eye, 649
 Cataclysmal haemorrhage after tonsillectomy, 397
 Cataract in iron workers, 905
 Census, the, 907
 Cerebro-spinal fever, studies in, 168
 Cervical defects, 59
 Chalmers, A. J., memorial to, 95
 Chemical industry, the fine, 133
 Children's dreams, 906
 Chinese honours for medical missionaries, 208
 Chinese Red Cross Society, 615
 Cinema, the retarded, 359
 Cockroach, the, 614
 Comparative medicine, 356
 Condensed milk. *See* Milk
 Congress of medical history, 950
 Congress of military medicine, 473
 Congress of radiology and physiotherapy, 205, 398, 471
 Cremation in England, 236
 Cretins, photographs of, 574
 Croom, Sir Halliday, resignation of, 946
 Czechoslovak public health delegates, 278, 311
 Decerebrate rigidity in man, 359
 Diabetes insipidus and the pituitary, 238
 Diphtheria carriers, 27
 Disabled soldier and the diamond industry, 358
 Dolling, Charles Edward, case of, 170
 Druce Act, Dangerous, Regulations, 96, 240, 789
 Edward VI, the birth of, 788
 Efficiency on view, 279
 Encephalitis, lethargic: Outbreak of, 277, 357; and epidemic hiccough, 572
 Epidemic of ureter, 825
 Everest expedition, 572
 Eye-strain in cinematograph halls, 281
 Fees of public vaccinators, 171
 Filariasis expedition, 280
 Fine chemical industry, 133, 315
 Flavouring agents in medicines, 27
 Food poisoning, outbreaks of, 170
 Friendly society support for hospitals, 712
 Gardening for the blind, 680
 Gas supply, dangers of the domestic, 313
 Gastric ulcers, persistence of after perforation, 613
 Goats and goat's milk, 651
 Gorgas memorial, 615
 Harrogate waters, 749
 Hiccough, epidemic, 28; and encephalitis lethargica, 572
 Hill, Professor Edward, of Dublin, 95
 Home ambulance service, 237
 Hospital almoners, 574
 Hospital for functional nervous disorders, 680
 Hospital Inquiry Committee, 96, 135, 170
 Hospitals and the income tax, 681
 Hunter, Colonel William, C.B., 787
 Hydrocephalus in achondroplasia, 455
 Hygiene of seamen, 538
 Ideals of a beloved physician, 947
 Immunity and industrial disease, 827
 "Index Medicus," new series, 614
 Industrial welfare and research, 435
 Industry, problems of, 748
 Infectious mononucleosis, 95
 Influenza pandemic 1918-19, 205
 Influenza infection, experimental, 94
 Institute of Physics, 679
 Insurance, National: Record cards, 59—Sanatorium benefit, transfer of, 135
 International health work, 825
Journal of Laryngology and Otolaryngology, 207
Journal of Obstetrics and Gynaecology of the British Empire, 713
 Keen, W. W., 84th birthday of, 279
 Labour, teaching of the mechanism of, 238
 "Laogham" Telephone Exchange, 393
 Langley prize in tropical medicine, 828
 Lard, nutritive value of, 501
 Laundry hygiene, 714
 Lectures in London, advanced, 786
Leptospira icterohaemorrhagiae, experimental infection with, 169
 Ligation of the left subclavian artery, 573
 Lighting, artificial, 711
 London University: Physiological laboratory of, 133, 205, 278—site (Holland Park), 134
 London University, sixteenth century scheme for a, 58
 Lymphocytes, fate of the, 905
 Lymphoblastosis, acuta benigna, 649
 Macdonald presentation fund, 206, 868
 Malaria in England, 502
 Malaria preventivo, 238
 Manchester Radium Institute, 471
 Maternity and child welfare centres and day nurseries, 504
 Mayo Clinic, 681
 Measles, experimental, acquired immunity after, 904

The Week (continued):

Measurement of human emotion, 280
 Meatless diets, 906
 Medical curriculum in Germany, 789
 Medical drainage of the biliary tract, 58
 Medical education in China, 313
 Medical History Congress, 950
 Medical Institute for Newcastle, 279
 Medical Insurance Agency, 788
 Medical Prime Minister, 826
 Medical scholarships for Serbian girls, 359
 Medical Society of London, 397
 Medical stores, surplus, disposal of to hospitals, 278, 828
 Medical students, instruction of in physics, 134
 Medical work in Kashmir, 714
 Medicinal herbs, 60
 Medicine of ancient Egypt, 472
 Medicine, history of, 750
 Mental therapeutics and the public, 948
 Midhurst Sanatorium, 650
 Milk, skimmed condensed, labelling of, 538
 Milk, pure and clean, 866
 Mitchell, S. Weir, 396
 Miners' housing, 539
 Mother, the unmarried, 749
 Motor fuel ecoron trials, 397
 Moulton, Lord, of Bank, death of, 433
 New year honours list, 58
 Obstetrical unit at the Royal Free Hospital, 714
 Ophthalmic work in Egypt, 503
 Ophthalmological Society's annual congress, 712
 Ophthalmology prize, 28
 Optophone, 574
 Ovaries, ablation of in mammary cancer, 615
 Oxford Ophthalmological Congress, 241, 949
 Parliamentary session, the new, 240, 280
 Pathological research applied to medicine, 616
 Pearl pathology, 827
 Pharmacology, clinical research in, 868
 Pharmacy, the future of, 948
 Physiology at South Kensington, 314
 Post-graduate Education Committee, 170
 Post-graduate instruction in Paris, 239
 Prince of Wales, 135
 Professional secrecy in courts of law, 904
 Psycho-analysis, quack, 133
 Psychotherapy, 168
 Public health in Czecho-Slovakia, 278, 311
 Public health officers, security of tenure for, 648
 Quack psycho-analysis, 133
 Radiological workers, protection of, 787, 947
 Radiology and Physiotherapy Congress, 205, 398, 471
 Radiology, research in, 536, 787
 Radio-therapeutics, research in, 787
 Rat extermination, 241
 Rats, ships, and crews' quarters, 866
 Reciprocity with South Africa, 949
 Red blood cells, diurnal changes in the size of, 239
 Red Cross, 713
 Red Cross Congress, International, 503, 537
 Red Cross war medal, 240
 Registrar-General's report for 1919, 169
 Research defence, 572
 Riviera in summer, 714
 Röntgen Society, 616
 R.A.M.C. war memorial, 536
 Royal Chest Hospital, 96
 Royal Naval Dental Service, 537
 Royal Society, 357—Conversazione, 748
 Royal Society of Medicine, 949
 Sanatorium benefit, transfer of, 135
 School punishments, 312
 Secret remedies and the German medical press, 649
 Serum diagnosis of syphilis, 950
 Service candidates, 682
 Silicosis and tuberculosis among miners, 26
 Small-pox, imported, 473
 Smoke abatement and the equipment of dwellings, 60
 Soyer, Alexis, 503
 Spelling of chemical terms, 539
 Spirochaetosis icterohaemorrhagica, 206
 Sport by artificial light, 867
 Strike, the: Emergency ambulance plans, 616
 Surplus medical stores, 278, 828
 Sussex provident scheme, 132
 Tell-tale treatment, 826
 Therapeutic substances not amenable to chemical analysis, control of, 357
 Thorburn, Sir William, 540
 Tropical medicine Langley prize in, 828
 Trypanosomiasis research, 434
 Tuberculosis Bill, the new, 470
 Tuberculosis in the Canadian Forces, 680
 Tuberculosis conference, international, 398
 Tuberculosis treatment, 539
 Tumours as malformations, 789

The Week (continued):

Typhoid fever in the United States, 713
 Typhoid vaccination statistics, 651
 University of Bristol, 649
 Unmarried mother, 749
 Venereal disease, campaign against, 27
 Venereal Disease Conference, North European, 682, 749
 Vienna and London, 169
 Vitamin, 828
 Vitaminee, 257
 War Emergency Fund, 28
 War finance of the Red Cross and St. John, 315
 War section of the Wellcome Museum, 314
 Women at Cambridge, 865
 Women on juries, 134
 Yellow fever investigations: In Mexico, 396; in Northern Peru, 436
 Well's disease. *See* Spirochaetosis icterohaemorrhagica
 Wellcome Museum. *See* Museum
 WELLS, H. Gideon: *Chemical Pathology*, rev., 707
 WELLS, Sydney Russell, knighthood conferred upon, 865
 WELSH, Robert A.: Braille type for blind children, 179
 Welsh Board of Health (parliamentary note), 909
 Welsh National Memorial Association and tuberculous milk, 34
 WERNÖE, T. B.: "Aesthesioscopia abdominalis," 435
 WESTCOTT, W. Wynn (and W. Harrison MARTINDALE): *The Extra Pharmacopoeia*, rev., 607
 WESTMACOTT, F. H., appointed Deputy-Lieutenant for Lancashire, 833
 WESTMAN, C.: Muscle re-education in infantile paralysis, 33
 WHALE, H. Lawson: Adrenaline in resuscitation, 137
 What we cannot afford (leading article), 56
 WHEELER, Sir W. I. de C.: A device to assist in the introduction of a pelvic drain, 197
 WHIDDINGTON, Professor: Eclipse blindness, 702
 Whisky, allowance to be drawn by Chicago druggists, 795
 WHITAKER, J. Ryland: *Anatomy of the Brain and Spinal Cord*, rev., 231
 WHITBY, Charles: *The Rising Tide, and other Poems*, rev., 197—Therapeutic tendencies, 466
 WHITE, S. E.: Cell activity and specific drug action, 685
 White lead. *See* Lead
 WHITFIELD, Arthur: Pruritus ani, 602
 Whitley councils (leading article), 56
 WINAL (and others, editors): *Nouveau Traité de Médecine*, rev., 195
 Wild-Barfield electric thermostat, 586
 WILKINS, A. G.: Refraction work in school children, 876
 WILKINSON, A. Norris: Scurvy in a breast-fed infant, 583
 WILKINSON, W. Camac: Specific treatment of tuberculosis, 307—The drooping shoulders sign of phthisis, 367
 WILCOX, J. W. James: X-ray radiation and cancer of breast, 247
 WILCOX, W. H.: Chemical estimation of gastric function, 383—Instrumental abortion, 461—Infective arthritis and allied conditions, 804 (O)—K.C.I.E. conferred upon, 865
 Willesden Municipal Clinics and Hospital, 171. *See also* Hospital
 WILLIAMS, Dawson: Knighthood conferred upon, 58, 61—Luncheon to, 309—Letter from the printing staff, 309—Dinner to, 325
 WILLIAMS, J. R., appointed Sheriff for County of Carnarvon, 447
 WILLIAMS, Leonard: Exophthalmic goitre, 425—The thymus gland in everyday life, 481
 WILLIAMS, W.: Glandular and pulmonary tuberculosis, 158
 WILLIAMSON, James: Refraction work in school children, 876
 WILLIAMSON, Oliver K.: Appointed Professor of Medicine at University College, Johannesburg, 69—Comparative systolic blood-pressure readings in the arm and leg in aortic incompetence, 734. (O)
 WILLIAMSON, R. T.: Ophthalmoscopic appearances in certain rare cases of diabetes, 120
 WILLOUGHBY DE BROKE, Lord: Venereal disease prevention, 100, 212, 758
 WILLOUGHBY, W. M.: Plague on shipboard, 640
 WILMER, W. H.: Effects of carbon monoxide on the eye, 649
 WILSON, Alexander, appointed Deputy Lieutenant for Lancashire, 833
 WILSON, C. M.: Exophthalmic goitre, 425—Some effects of the war on industrial unrest, 825

WILSON, J. Alexander: Eyestrain in cinematograph halls, 322
 WILSON, Major Norman M., O.B.E. conferred upon, 917
 WILSON, R. Macnair: Relation of temperature to the onset of a cardiac irregularity, 226. (O)
 WILSON, S. A. Kinnier: Decerebrate rigidity in man, 359—Exophthalmic goitre, 425—Ocular palsies, 426
 Wine allowance to be drawn by Chicago druggists, 795
 WINGFIELD, H. E.: *An Introduction to the Study of Hypnotism, Experimental and Therapeutic*, rev., 567
 WISHART, John: Delivery of child and placenta in unruptured membranes at term, 108
 WOLLASTON, Alexander F. R., chosen as medical officer of the Mount Everest Expedition, 253
 Women at Camoridge, 865. *See also* University of Cambridge
 Women on juries, 134. *See also* Juries
 Women, medical. *See* Medical
 WOOD, Casey A. (and Fielding H. GARRISON): *A Physician's Anthology of English and American Poetry*, 277
 WOOD, Denis R.: Isolation of diphtheria bacilli, 562. (O)
 WOODCOCK, H. M.: Endemicity of intestinal protozoa, 363
 WOODHOUSE, H. C. (and F. Carlton JONES): Bradycardia, 577
 WORK, Hubert, appointed First Assistant Postmaster-General in the United States, 795
 Workmen's Compensation Act and suicide, 34
 WORTHINGTON, Colonel Sir Edward, Belgian Croix de Guerre conferred upon, 253—C.I.E. conferred upon, 549
 WOSILO, Erich: *Kystoskopischer Atlas*, rev., 387
 Wounded in hospital (Ireland), 477
 Wounds, infected, studies of (Captain S. B. Douglas, A. Fleming, and L. Colebrook), 235
 WRIGHT, Sir Almoth: Acidaemia, 319—Awarded gold medal of the Royal Society of Medicine, 950
 WRIGHT, Lieut.-Colonel Andrew Rae, Belgian Croix de Guerre conferred upon, 253
 WRIGHT, Robert E.: Involvement of the orbit in diseases of the nasal accessory sinuses, 561. (O)
 WYNNE, F. E., appointed M.O.H. for Sheffield, 215—Presentation to, 516

X.

X-ray dermatitis, 662
 X-ray radiation and cancer. *See* Cancer of breast
 X-ray and Radium Protection Committee, constitution of, 787—Preliminary report, 936—Note on, 947
 X Rays, Limited, catalogue, 108
 X rays and radium, action of on tumour growth (S. Russ, Helen Chambers, and Gladys M. Scott), 229
 X rays, review of book, 346
 X rays for ringworm, the risk of baldness, 32
 X rays and radium therapy, discussion on, 304

Y.

Yellow fever. *See* Fever
 YELLOWLEES, Henry, appointed superintendent of The Retreat, York, 706
 YELLOWLEES, David, obituary notice of, 177
 YERKES, Robert M. (and Knight DUNLAP, editors), *Journal of Comparative Psychology*, vol. 1, No. 1, rev., 818
 Yokohama, naval hospital at (parliamentary notes), 476, 576
 YOUNG, Archibald: Treatment of gastric and duodenal ulcers, 123—Thoracic duct wounded in removal of tuberculous cervical glands, 564
 YOUNG, A. E.: Adrenaline in resuscitation, 482
 YOUNG, James (and Douglas A. MILLER): Etiology of eclampsia and the pre-eclamptic state, 485. (O)—Life-cycle of an organism cultivated from carcinoma, 933
 YOUNG, Joseph, obituary notice of, 724
 YOUNG, W. J.: Prevention of puerperal infection, 874

Z.

ZINSSER, H. (and others): *Typhus Fever, with Particular Reference to the Serbian Epidemic*, rev., 857

For List of Illustrations see back of Title.

THE
British Medical Journal.

THE JOURNAL OF THE BRITISH MEDICAL ASSOCIATION.

LONDON: SATURDAY, JANUARY 1st, 1921.

A British Medical Association Lecture

ON THE

DIAGNOSTIC SIGNIFICANCE OF ABDOMINAL PAIN IN CHILDHOOD.*

BY

ROBERT HUTCHISON, M.D., F.R.C.P.,

PHYSICIAN TO THE LONDON HOSPITAL, AND TO THE HOSPITAL FOR SICK CHILDREN, GREAT ORMOND STREET.

ABDOMINAL pain in a child must always be a source of anxiety to the doctor. It may mean so little or so much. It may be due to nothing worse than an attack of acute indigestion set up by a green apple; or it may indicate an attack of acute peritonitis set up by a green and gangrenous appendix. It is a matter, therefore, which craves wary walking in diagnosis, for a mistake may be fatal, and between one's anxiety not to overlook a serious cause and one's natural reluctance to alarm the parents unduly it is often difficult to steer a proper course. Our difficulty in these cases is increased by the fact that pain may be the sole symptom of abdominal disease, and the little patient may be unable to help us, as an adult can, by describing its exact situation, character, and so forth, which are often so significant for diagnosis. It seemed, therefore, that we might profitably employ our time this afternoon by considering together the chief causes of abdominal pain in childhood, with a view to enabling us, when we meet such cases, to make a diagnosis by the method of exclusion if no other is available.

EXTRA-ABDOMINAL CAUSES OF PAIN.

At the outset it is well to remember that pain felt in the abdomen is not necessarily being caused there. In children, who localize their sensations badly, these extra-abdominal causes of pain are specially apt to lead to error. We may divide them according as the cause has its seat (1) in the abdominal wall, using that term in its widest sense, or (2) in the thorax.

1. Causes in the Abdominal Wall.

Spinal Curves.—Of causes situated in the abdominal wall this is one of the commonest. The pain in such cases is due, of course, to pressure on the posterior nerve roots, and is usually referred along the lower intercostal nerves to the epigastrium. It may come on quite early in the disease before any gross spinal deformity has shown itself, and the child will be brought to you under the belief that he is suffering from some abdominal trouble. It is well, therefore, to make it a rule carefully to examine the back in all cases of chronic epigastric pain in children. Slight prominence of one or more vertebral spines in the lower dorsal region can usually be detected, with tenderness on percussion over them and some stiffness on stooping. If in doubt, one can call in the help of the radiographer.

Lateral curvature in its more pronounced degrees is a similar source of error, but is less likely to be overlooked.

Rheumatism, or perhaps one should call it fibrositis, affecting the abdominal muscles, may easily simulate pain of intra-abdominal origin, and, like all rheumatic manifestations, is relatively common in childhood. It may be

met with either at the insertion of the muscles into the ribs or iliac crests or in the aponeurotic sheaths of the muscles themselves. The well-known "stitch in the side" which is common in children may, perhaps, be of this nature, but it is also met with in a chronic and protracted form. Fibrositis may be distinguished by the fact that the pain comes on when the affected muscle is thrown into action, as, for example, when the patient tries to sit up in bed without using the hands; there is often quite acute tenderness at certain parts of the abdominal wall, especially when the muscle is contracted, and if the abdomen is palpated in the ordinary way this may be mistaken for tenderness of an underlying organ. This error may be avoided by noting that tenderness is also elicited when the abdominal wall is grasped or compressed laterally. This form of pain is commonest in children of school age, and often follows hard exercise, and if the muscles of the right lower quadrant are involved appendicitis may be simulated. One sometimes wonders whether cases of so-called "rheumatic appendicitis" cured by salicylates are not really of this nature.

Herniae through the abdominal wall are not such a common cause of obscure chronic abdominal pain in the child as they are in the adult; but in the form of omental herniae especially they should always be thought of, and so should the possibility of an *undescended testis*.

Hip disease I have sometimes known to lead to error; not so much tuberculous hip disease as an acute inflammatory condition in or near the joint. This may cause pain referred to the lower part of the abdomen; there may be fever and the child may lie with the legs drawn up; and when the right hip is affected simulation of appendicitis may be fairly close. The limitation of movement in the joint which careful examination reveals ought, however, to keep one right.

Herpes zoster is the last of the causes in the abdominal wall which I shall mention. Pain in this affection may precede the appearance of the eruption by some hours or even days, and be of considerable severity; and I have known more than one instance in which it led to a diagnosis of acute abdominal disease. It can be distinguished by the fact that there is a band of superficial hyperaesthesia in the distribution of the affected nerve, that there is also severe pain behind, near the vertebral spines, and that deep tenderness on palpation or involuntary rigidity are absent. All doubts are dispelled before long by the appearance of the eruption.

2. Thoracic Causes.

The possibility of abdominal disease being simulated by acute intrathoracic conditions has been well recognized ever since attention was first directed to it by the late Mr. Barnard some years ago. Yet mistakes are still easy to make. The commonest form of error is to diagnose a case of pneumonia occurring at the right base as one of appendicitis. If the patient is a child, such an error is specially excusable, for in the child, more even than in the adult, the physical signs of a pneumonia may be entirely absent for some time after the disease has begun. Furthermore, vomiting is a very constant and conspicuous feature of early pneumonia in childhood, and helps still further to simulate the picture of abdominal disease. The abdominal pain in these cases is due, as you all know, to involvement of the lower intercostal nerves as they pass through the diaphragm, and in part also it may be a "referred pain." There is reason to believe that it only occurs when the diaphragmatic pleura is affected. Be this as it may, the

* Delivered before the South Midland Branch on July 8th, 1920.

combination of an acute onset, with fever, vomiting, pain referred to the lower abdomen, and some abdominal rigidity, coupled with an absence of the usual signs of pneumonia, may be deceptive in the highest degree. In attempting to make a diagnosis in such a case you will look for an alteration in the pulse-respiration ratio, though it is well to remember that the respiration is not always hurried at the onset of pneumonia in a child. You will note that the abdominal tenderness is superficial, and that there is no sign of pain on moderately firm deep palpation. You will also ascertain the presence or absence of tenderness in the recto-vesical pouch on examination by the rectum, although perhaps it is true to say that in the child this is more easily said than done. You will remember, also, that the higher the temperature the more likely is it that the case is one of pneumonia. In some cases you must remain in doubt, and then it is wise to stay your hand, and in a few hours, perhaps, the appearance of a pleuritic rub or a patch of dullness will make clear the nature of the disease.

Pericarditis, but apparently only when the diaphragmatic surface is involved, may also simulate abdominal disease, although it is much less common as a source of error than pleurisy or pneumonia. I remember a case of the sort which made a strong impression upon me at the time. The patient was a little boy, who was admitted to hospital under the belief that he had acute appendicitis. He looked very ill, lay with the knees drawn up and the abdomen rigid, complaining of pain which he referred to the hypogastrium. There was moderate fever, but an entire absence of other signs. I have forgotten whether he vomited. He was kept under observation for a few hours, and it was decided that if there were no more positive indications by the evening the abdomen should be opened. Just before the time agreed upon for this, however, a loud pericardial rub became audible, and the case subsequently ran the course of an ordinary rheumatic pericarditis.

INTRA-ABDOMINAL CAUSES OF PAIN.

Let us now pass on to consider the far more frequent cases in which the cause of pain is situated in the abdomen itself. We may divide these for the sake of convenience into (1) cases of sudden or catastrophic pain, and (2) cases of chronic or recurrent pain.

Sudden Catastrophic Pain.

By the "catastrophic" cases I mean those in which the pain sets in suddenly—"out of the blue" so to speak—and is of great intensity. They are the cases often spoken of as "abdominal catastrophes," and include many examples of what are known in surgical slang as "the acute abdomen." They are for the most part of surgical rather than medical interest, and I shall not say much about them except to point out as far as one can those in which immediate laparotomy is indicated.

At the outset it may be well to remind you that the possible causes of an abdominal catastrophe are far fewer in the child than in the adult. Children do not suffer from perforated gastric or duodenal ulcer, for instance, or from acute pancreatitis, and I can recall only one case of biliary colic in a child. The possibilities which one has chiefly to consider when confronted with a case of severe abdominal pain of sudden onset at this age are acute indigestion, appendicitis, and some form of acute intestinal obstruction, of which that due to intussusception is specially frequent in the child. Amongst the rarer causes one might perhaps mention abdominal or Henoch's purpura. Renal colic, which may also have to be considered, I shall have occasion to mention later on.

The immediate practical diagnostic problem in such a case is to eliminate *acute indigestion*. This is not always easy. The pain of acute indigestion may set in suddenly, may be of great severity, and may be attended by fever and considerable distress. Here is an example. A boy of 7, whilst convalescing from a mild attack of whooping-cough, was attacked by sudden abdominal pain of considerable severity, and in an hour or two his temperature had run up to 104°. He was restless and distressed, and begged that "something should be given him to relieve his pain." In view of the recent whooping-cough various diagnostic possibilities presented themselves, but soon one's doubts were solved by the copious vomiting of a quantity of undigested food, shortly after which he broke into a profuse sweat, and the temperature came down with

a run. If in doubt about such a case, the best course is not to pool-pool the whole affair as a mere stomach-ache and to give a dose of castor oil—still less an opiate—but to hold one's hand and wait. Meanwhile, there is no harm in giving an enema, and perhaps a mild emetic, and applying heat to the abdomen for relief of the pain.

The possibility of *appendicitis* is what will give you the most anxiety in these acute cases of pain. I shall not go into the diagnostic criteria in this matter in any detail, as they are much the same as hold good in the case of the adult; but I would only remind you that pain is the *earliest* symptom in appendicitis, that it is usually experienced first in the epigastrium, and only later settles into the right iliac fossa, and that it is rarely of great severity except in a very nervous child. Vomiting nearly always occurs, but it follows the pain and does not persist, as it does, for example, in cyclical vomiting; and although more or less fever is always present at some stage of the attack, it is rarely great in degree. In looking for muscular rigidity in children, light palpation is more important even than in the case of the adult.

Acute intestinal obstruction is nearly always attended by pain, which may be very severe, but I have seen cases of intussusception in which, at the outset at least, pain was entirely absent; probably they were cases in which there was an unusually long mesentery. The classical signs and symptoms of obstruction will be present in the child as in the adult, but it is well to remember that, owing to the tendency of the child to develop a temperature on slight provocation, some fever may be present even in purely obstructive cases, especially, perhaps, in intussusception. In the examination of these cases an anaesthetic is often of great help. It saved the situation in the case of a little boy whom I saw not long ago, who had been seized two days previously with severe abdominal pain. Other symptoms of intussusception were absent, but the abdomen was rather rigid and difficult to examine. He did not seem at all ill, and one was inclined to regard it as a case of colic, but under a whiff of chloroform the abdominal walls immediately relaxed, and a typical sausage-shaped tumour could then be felt running across the abdomen.

I have mentioned *abdominal purpura* as a possible cause of sudden acute pain. You will not expect to meet with this often, but as it is usually attended by haemorrhage from the bowel, it may simulate intussusception rather closely. A mistake may be avoided by careful examination for purpuric blotches in the skin, which are often to be found in such cases.

Chronic or Recurrent Pain.

When an adult complains of chronic pain in the abdomen the first organ one thinks of is the stomach. In the child, however, the stomach is rarely at fault in such circumstances. Children, I need hardly remind you, do not suffer from organic disease of the stomach, such as ulcer or carcinoma, and in them chronic or recurring abdominal pain usually has its seat of origin in the intestine. It is true that ordinary indigestion may cause some pain, probably from distension of the stomach with gas, but it is rarely severe in degree—rather a mere discomfort—and its definite relation to meals and its relief after the belching up of wind will usually make the nature of the case plain. The intestinal cases are, as I have said, far commoner, and we may divide them for convenience into those due to (a) ordinary colic, (b) "umbilical" colic, the meaning of which is to be explained immediately, (c) enterospasm, and (d) chronic obstruction.

(a) *Ordinary colic* is, of course, the commonest cause of abdominal pain in little babies, but it is met with also often enough in older children, and may contribute to the pain in those cases of acute indigestion of which I have already spoken. In the chronic or recurrent form it is more apt to appear as the variety known as "umbilical" colic, of which I shall speak presently. In whatever form it shows itself it is characteristic of colic that the pain occurs in spasms, that it is relieved by firm pressure—differing in this profoundly from the pain of appendicitis, for instance—and, what is of great diagnostic value if it is observed, that it is relieved, temporarily at least, by the expulsion of flatus from the bowel.

(b) The term "*umbilical*" colic was introduced by Professor Moro to designate a common group of cases, met with in children of school age, in which the patient

complaints of frequently recurring abdominal pain, which is always referred to the situation of the umbilicus. The pain may come on suddenly at any time in the day, but sometimes quite definitely after or during a meal. It may be severe whilst it lasts, even doubling the child up, and may be attended by sudden pallor. Vomiting is rare. The attack may last for only a moment or two or for a few hours, and there is sometimes a tendency for attacks to exhibit periodicity. As I have said, these cases are by no means uncommon, and every one who has done much outpatient work amongst children must be familiar with them, but their real nature is obscure. There are usually no objective signs of disease to be made out, and More was of opinion that the condition is a pure neurosis. I can hardly think this likely, and it seems more probable that we are dealing in these cases with a genuine colic in the large intestine occurring in rather constipated nervous children in whom perhaps the "gastro-colic" reflex is abnormally active—a condition closely akin to henteric diarrhoea. Of the treatment of these cases, which is troublesome enough, there is no time to speak to-day, but their chief importance arises from the fear that in them one may really be dealing with "chronic appendicitis," but on that subject I shall have something to say in a moment.

(c) *Enterospasm* as a cause of abdominal pain is met with in children who are the subject of muco-membranous colitis. This is not infrequent in childhood, and when spasm of part of the colon occurs very severe pain may be produced. The contracted bowel may sometimes be felt, usually in the left iliac fossa, and the presence of mucus and membranes in the stools should make the diagnosis clear. It is worth remembering that muco-membranous colitis in children is sometimes attended by prolonged fever of considerable degree, and when attacks of enterospasm are superadded mistakes in diagnosis may easily occur.

(d) *Chronic intestinal obstruction* as a cause of abdominal pain is rare in childhood, and when it occurs is usually due either to compression of the bowel by a band, or a persistent Meckel's diverticulum, or to adhesions the result of old tuberculous peritonitis. The pain resembles that of colic in its nature, but there is usually some meteorism present, and visible coils of intestine may be seen. There is not necessarily any vomiting. The use of the x rays may help in the diagnosis if one is in doubt. The most difficult cases are those due to chronic intussusception, and in at least two instances of that condition I have known the true cause of the pain overlooked, even though the patient was for a long time under observation in hospital.

APPENDICULAR PAIN.

I now come to the most anxious cases of all—those, namely, in which the question arises whether a chronic or recurrent pain has its seat in a diseased appendix. There are some, I believe, who deny the existence of chronic appendicitis in childhood altogether. I think I have heard a surgeon say that a child either has acute appendicitis or the symptoms are not due to the appendix at all. Most of you will probably agree that this is an extreme view, but at the same time I am sure that one ought to be extremely cautious in diagnosing chronic appendicitis in children, especially when the pain is confined to the right side of the abdomen. On the other hand, it is probably nearer the truth to say that disease in the appendix in the child is never chronic from the beginning, there is always a preceding acute or subacute attack. In making a diagnosis, therefore, a history of such attacks should be inquired into with great care. They will usually be described as "bilious attacks," but if they were attended by pain, some vomiting, and fever, and were bad enough on any occasion to confine the child to bed, one should be very suspicious. Physical examination in cases of chronic or relapsing appendicitis *between attacks* may be entirely negative, and I do not think that the use of x rays affords much help. One must often be in doubt between chronic appendicitis and "umbilical colic," but if there is a clear history of "bilious attacks," and if the parents, as so often happens, are worried about the state of the appendix, then I think it is best to advise exploration, although it is unwise to guarantee any result from the operation other than the relief of the parental mind.

Worms are often believed by parents to be a cause of abdominal pain in childhood, but my own experience

would not bear this out. Round worms are those which would be most likely to produce the symptoms, for they are sometimes numerous enough even to produce intestinal obstruction. A vermifuge will soon settle the diagnosis.

Enlarged glands, on the other hand, are, I believe, a much commoner cause of abdominal pain in children than is generally realized. I do not mean necessarily tuberculous glands, but a simple enlargement of the glands at the lower end of the mesentery. These often become infected in cases of appendicitis in children, just as the glands at the angles of the jaw do in tonsillitis. I saw a very striking example of this not long ago in the case of a boy who was suddenly attacked with pain, vomiting, and fever. He presented the signs of appendicitis, but there was a curious tumour about the size of a walnut to be felt in the right iliac fossa which was certainly not the appendix. At operation it proved to be a mass of acutely inflamed glands, the appendix being also inflamed and its mucous membrane ulcerated. There is often no history of any acute disease in these cases of chronic enlargement of glands, though no doubt they must have been infected from the caecum or appendix; but, once enlarged, they are apt to cause pain in the right lower quadrant, possibly by dragging upon or kinking the bowel. At all events they are often the only thing found wrong in children on whom an exploratory operation has been performed for suspected chronic appendicitis, and their removal is usually followed by disappearance of the attacks of pain.

CAUSES IN THE URINARY TRACT.

Affections of the urinary tract are a frequent and often overlooked cause of abdominal pain in early life, just as they are in the adult, although some conditions which are relatively common in grown-up persons are rare in the child. Movable kidney, for example, though it is occasionally met with in children, need hardly be thought of as a cause of pain. Attacks of true renal colic also are not often exhibited in the child, though gravel is perhaps a not uncommon cause of pain in babies. On the other hand, there are two conditions which are certainly more frequently sources of abdominal pain in the child than is generally realized: one is *kinking of the ureter* and the other is *ureteric calculus*.

Kinking of the ureter results, as you know, from a congenital abnormality in the distribution of the renal blood vessels. As a rule it does not produce symptoms until early adult life, but I believe that it would be diagnosed oftener in the child if it were looked for. It is one of the causes of so-called "bilious attacks." I had once a very striking example of this in the case of a boy of 15, who was alleged to have suffered since his early childhood from attacks of abdominal pain and vomiting which recurred every few weeks with great regularity. They had been diagnosed as "bilious attacks." I happened to see him in an attack. He referred the pain to the left loin, and an enlarged and slightly tender kidney could easily be felt on palpation. Surgical investigation established the presence of kinking of the ureter, and a greatly disorganized kidney was subsequently removed. These cases are deceptive because of the regular periodicity of the pain and the entire absence of any urinary symptoms.

Ureteric Calculus.—Just as the symptoms of a kinked ureter are apt to be diagnosed as "bilious attacks" so the symptoms of a ureteric calculus, when it occurs in the right side, are usually attributed to "chronic appendix mischief," and indeed the simulation may be very close. There may be a history of attacks of right-sided spasmodic pain; there may be a rise of temperature and tenderness over the ureter (which is very close to McBurney's point), and urinary symptoms may be absent. The moral is that a radiograph of the ureteric region should always be taken before an operation is performed in quest of a supposed diseased appendix.

In the male *urethral obstruction* as a result of phimosis or a narrow meatus may cause attacks of hypogastric pain from over-distension of the bladder, but the association between the pain and the difficulty of micturition is usually obvious, and the vesical tumour easily made out. In girls, on the other hand, one has sometimes to think of *pelvic causes* such as salpingitis, but I mention these rather for the sake of completeness than because I regard them as common causes of abdominal pain in childhood.

A Clinical Lecture

ON

EPILEPSY CONSIDERED AS A SYMPTOM,
NOT A DISEASE.

BY

JAMES TAYLOR, C.B.E., M.A., M.D., F.R.C.P.,

PHYSICIAN TO THE NATIONAL HOSPITAL FOR THE PARALYSED AND
EPILEPTIC, QUEEN SQUARE; CONSULTING PHYSICIAN TO
MOORFIELDS EYE HOSPITAL AND TO THE QUEEN'S
HOSPITAL FOR CHILDREN.

So much has been written about epilepsy from the earliest times that it may seem presumptuous in anyone to think or hope that he may contribute something new to such a subject. I should make no such claim, for I feel sure that much of what I am about to say has been said before, although it may have been said differently, and the subject may have been approached from a somewhat different angle. I have been fortunate enough to have a considerable experience of this disease, if disease it is to be called, during a good many years, and I have been not a little disappointed and surprised at the tendency which has lately become obvious towards an attempt to approach its explanation on other grounds than that of physical disturbance—in my opinion, a definitely retrograde movement.

In a recent paper¹ Dr. Pierce Clark, apparently despairing of any physical interpretation of epileptic phenomena and curiously oblivious of the constant tendency in Hughlings Jackson's writings, sets himself to explain them on a psychological basis. Such a psychological basis for phenomena of which the physical symptoms are so distinct, requires much ingenuity and not a little imagination. It seems to me that it would be just as reasonable to require a psychological basis for Jacksonian fits, or for uraemic convulsions, or for the convulsions produced in a monkey by the intravenous injection of absinthine, as for the phenomena of what has been called epilepsy. With regard to the so-called "latent phenomena" of epilepsy we frankly have no belief in them. We happen to know men (and women too) subject to occasional convulsive attacks, who on ordinary occasions are normal healthy individuals, working regularly, doing good work, capable intellectually and physically, in whom the most earnest psychological analyst or observer would fail, we feel sure, to detect any abnormality. And to say that "transitory phobias, ecstasies, and most common of all, irritable and depressive states," are characteristic of latent epilepsy, is to make statements which any physician is able out of even a limited experience, to contradict explicitly. Even of so-called advanced cases of epilepsy—by which we understand is meant cases subject to recurrent convulsions during many years—to say that these are characterized by "ethical depravity of the entire personality" is to state what in the experience of many of us is not correct. Every physician knows that such "ethical depravity" is not uncommon as a degenerative sign without any tendency to convulsion; and what is spoken of as an "egocentric contraction of the entire emotional life," characterized by pathological lying, etc., is certainly not symptomatic of, or confined to, patients who are the unfortunate subjects of repeated convulsions.

Dr. Pierce Clark says he undertook a study of the "character make-up" in a small series of "essential epileptics" before they had their first attack. It would be interesting to know whether this study was really made before the first attack or was an afterthought. If it was made before the first attack one would like to know the basis for his belief that attacks were coming; if it was made after the attacks were established then of course it loses any little value it might have had. He says he found "nothing wanting in the complete picture of the character as seen in those suffering from a long enduring and severe epilepsy." He also remarks on the different attitudes of "trained clinicians" in epileptic colonies and physicians in private practice. He seems to deny the title of "trained clinicians" to physicians in practice. Does he not think that the so-called "trained clinician" in an epileptic colony is much more likely to be biased in his views than is a man who is at least equally well trained, and much more widely experienced in varied forms of disease? He even

claims that the colony physician has a much broader view of the whole problem, which, of course, is absurd, seeing that he is dealing with advanced and apparently incurable cases, and has no experience (or ignores it) of patients subject to occasional attacks who are able to get about, to do good work, and of whose tendency to occasional attacks everyone, except their immediate relations and their physician, is in complete ignorance. The colony physician surely has a narrow and restricted view of these phenomena because his patients are of a class only suitable for institutional treatment—for, as the author confesses, the institutional physician "receives the most badly deteriorated patients." It is quite beside the mark to say these are "fearfully handicapped by drug and surgical treatment." The point to be recognized is that as a class they are deteriorated. But it does not at all follow that the numerous patients subject to occasional convulsion—many of them active and useful and energetic members of society—are to be regarded as the subjects of the same psychological condition as those institutional inmates.

With special reference to Dr. Pierce Clark's assumption that there is something in the so-called "psychological make up" of patients usually called epileptic, I will now mention briefly some cases which have come under my own observation which to my mind afford clear evidence that patients who have suffered from these so-called epileptic fits have no signs of either physical or mental deterioration.

The first case is that of a healthy-looking man of 50, who consulted me some years ago on account of several convulsions occurring in the previous year. He was an energetic business man, busily engaged in the control of a large and important business in which he had been usually successful. The history was that at the age of 17 he had had an attack in every way similar to those for which he consulted me. He was put on simple treatment, his activities, mental and physical—he was a keen lawn tennis player and golfer, as well as an active business man—were in no way interfered with, and he went on well. Soon after I saw him he was elected Provost of an important town in Scotland, and the duties of this office—extremely exacting throughout his years of office during the war—were carried out in such a way as to earn him praise from everyone, and recognition in the highest quarters. He still pursues his active business career and is in every respect a healthy man. He has entirely left off medicinal treatment.

The next case is that of a young man of excellent physique, who two years before the war had on successive days two generalized convulsions. He was put on medical treatment, which was continued in gradually decreasing doses for two years. There was no recurrence of any kind, and he served in the army during several years of the war. He is, and has been since he was demobilized, actively engaged in an extremely responsible position in a business house, and has remained quite well.

The next case also is that of a young man—a hospital patient, engaged in electrical work, who for some years had been subject to recurrent convulsions, with loss of consciousness. He had been compelled by the frequency of these to give up his work, and treatment at first only succeeded in abating the frequency and severity of the attacks. Persistence in treatment, however, was finally successful in completely controlling them, and for over a year now he has been free from attacks, and has been actively engaged in his somewhat arduous and responsible work.

The next case was certainly at first sight not a promising one—a lady between 50 and 60, who had been subject for many years to convulsive attacks, with loss of consciousness. These occurred at varying intervals—sometimes of months, occasionally of days—and there were also occasional minor attacks. Treatment on rational lines in her case was also successful, and she has now been for over a year free from attacks, living the ordinary social life of a lady of good position, and occupying herself much in good works.

The last case I shall mention is that of a lad whom I saw five years ago, who had then had only a few attacks, always in the morning after getting up. He had one or two after treatment was commenced, but none in the last two years, and he is now actively engaged in study at one of the universities.

I could mention other cases, but these will suffice to emphasize the point I wish to make, namely, that patients who have been the victims of attacks—even if these have been spread over a good many years—do not necessarily deteriorate either physically or mentally. I may mention that in all these cases bromide has been the “sheet anchor” in treatment, but this, like other drugs, must be used with intelligence and discrimination, both in regard to dose and mode of administration. Of course, no one with any experience of these cases of convulsion can think of denying that there are cases—unfortunately not a small class—in which treatment is inefficacious, and in which the convulsions persist in spite of all one's efforts at treatment. These we must assume are cases in which degenerative processes are superadded to some local disturbance, or cases in which the local disturbance is so situated or is of such a nature as to lead to such changes. But it seems to me unreasonable to suppose that such cases are the result of anything but physical changes.

I think that in the past we have given far too much attention to those cases of generalized recurrent convulsions to which the name of epilepsy has been applied, and too little attention to those cases of localized or Jacksonian attacks which were also described by Bravais. For I believe it is by a study of these and of their relation to the cases of so called ordinary epilepsy that any real step forward in the elucidation of the nature of these ordinary cases, and in their treatment, is to be looked for.

Although I was under the impression that I had arrived at this belief independently, I have little doubt that I must have imbibed the substance of it from Dr. Hughlings Jackson's teaching. For I have recently found that so long ago as 1874 he wrote as follows:

“I have long been convinced that ‘idiopathic epilepsy’ is far too difficult a subject for precise investigation unless we approach its consideration from the bases supplied by the principles deduced from the less complex kinds of cases.”

Again he says:

“Epilepsy like aphasia has been studied with a psychological habit of mind, and, as I think, this way of studying such a disease is unfruitful.”

Let us now consider for a moment these cases of localized or Jacksonian fits. These fits are recognized as the result of changes occurring locally in the brain giving rise to signs of irritation in the peripheral structures, motor or sensory, related to the unstable brain area.

We need not consider now the nature or cause of the irritability. It may, of course, be various. A certain part of the brain is irritated, movement is produced in a peripheral part and may remain restricted to this, or the movement may spread so as to affect all parts of the body, and also affect consciousness, this being the result of a spread of irritation from an unstable area to normal structures. In other words, the convulsion may become general—any Jacksonian fit may become a general convulsion—the convulsion may start as the result of irritability in some unstable cells, but the irritability may spread from this focus or fulminating area and cause discharge in structures which are quite healthy and normal. It is not uncommon for a patient subject to Jacksonian attacks to suffer from attacks of varying degree. On one occasion the convulsion may affect only a finger and thumb; on another occasion it may spread to affect a whole limb; or on still another the convulsion may affect the whole body, and if this happens, consciousness is almost always, if not invariably, lost. If the convulsion is a purely local one, consciousness is nearly always retained, and not infrequently a local convulsion is prevented from spreading by firm pressure on, or pulling of, the limb proximal to the part already in a state of movement. Many such cases have been published, and the evidence is familiar to all students of this disease. In such a case we are justified in assuming that there is some local condition—it may be mechanical, it may conceivably be chemical or nutritional, rendering a few cells unstable and inducing in them a tendency to the discharge of nervous energy; and the instability of these cells may, unless it is by some means prevented, as by some strong effect on the peripheral structure, induce in contiguous healthy cells a similar instability and tendency to the liberation of nervous impulses. If this spreads widely enough a general convulsion may result.

As an illustration of what I have here said I may

mention the case of a patient seen with Dr. Fawcett and Dr. Spon, and subsequently by Mr. Percy Sargent. The patient was a healthy man who had for some time suffered from fits, some slight without any loss of consciousness, others more severe with general convulsion and loss of consciousness. All the fits, whether slight or severe, started with a sensation and subsequent movement in the right lower limb. Sometimes the convulsive movement affected only this limb and consciousness was not lost. In others the movement spread from this limb and became generalized, and consciousness was lost. It was obvious that in this case the focus of irritation was in what is known as the leg area of the left hemisphere, an area near the middle line. There was no headache and no optic neuritis, but the condition was regarded as probably the result of the irritation caused by a tumour growing in or from the meninges in this region, and Mr. Sargent was able to remove a growth of a non-malignant character from the situation in which it was possible to foretell its presence. I have purposely refrained from over-burdening this brief account of this case with details which are unnecessary for our present purpose, which is to show that local irritation may give rise to only a local disturbance in the peripheral parts—a Jacksonian fit—or may result in a general convulsion commencing locally. I may mention that although the fits in this case occurred once or twice after the operation, and although there was some subsequent weakness of the affected side, the fits have now been absent for some years.

There is a class of patients consideration of the cases of whom is very instructive from the point of view of local irritation causing fits. I refer to cases of so-called infantile hemiplegia the result of an inflammatory condition similar to that occurring in the spinal cord causing infantile paralysis, and probably identical in origin. The initial illness is usually acute, characterized by violent convulsion, feverishness, etc. The convulsions in such cases commence unilaterally, and during the acute stage become general, and there is not infrequently a condition of *real status epilepticus*. If the patient recovers, the resulting condition is one of hemiplegia, sometimes very severe, sometimes very slight, and in after-life there is a liability to the occurrence of convulsions, sometimes only unilateral of the affected side of the body, sometimes spreading from such a commencement to become general.

I might here digress for a moment to recall the fact that besides the severe general convulsion with tonic and clonic spasm—*grand* or *haut mal*—which occur in so-called idiopathic epilepsy, there are also conditions of *petit mal* in which there may be only momentary loss of consciousness without convulsion. I now proceed to relate a case which was under my care and observation for some years that of a woman of 25 with a definite history of convulsion occurring in early life in the course of a feverish attack, and resulting in slight right-sided weakness. The hemiplegia, it was said, passed off, but there was still slight right-sided weakness. The patient was left-handed, but was able to write with the right hand, and the condition was obviously one of very slight right hemiplegia dating from early life, and apparently the result of an attack of polio encephalitis of the left hemisphere. She consulted me on account of her liability to occasional “fits,” apparently general convulsions, starting in the right hand. But even more troublesome than the attacks of severe convulsions, which did not occur very often, were attacks of *petit mal* of frequent occurrence, and often followed by a condition of “automatism” in which apparently purposive acts were carried out quite unconsciously.

Such attacks of *petit mal* with automatism are supposed to be characteristic of so called essential or idiopathic epilepsy, and I would urge that a case such as that which I have just related is somewhat strong presumptive evidence that such a condition of *petit mal* is probably in other cases associated with actual structural changes in the brain, just as it certainly was in the case I have related. I do not here refer to the explanation of the automatism.

Dr. Hughlings Jackson was, I believe, the first to direct our attention to an exceedingly interesting class of cases, in which the chief symptoms were a curious aura of “reminiscence,” also spoken of as the “intellectual aura” or “dreamy state,” in which the patient seems to be passing through a familiar experience so that he almost knows what is coming next, and this is usually, although

not invariably, associated with a curious but indescribable, often disagreeable, smell. To such cases Dr. Jackson applied the name "uncinate epilepsy," because in some cases in which such an aura was associated with convulsions, or at least with loss of consciousness, a lesion was found in the uncinate gyrus of the temporo-sphenoidal lobe.

In some cases the lesion was a tumour, in one case a small non-malignant cyst. In the case¹ in which the cyst was found by Dr. Walter S. Colman the patient was a medical man who had been subject for many years to recurrent attacks ushered in with the "dreamstate." In this case the cyst was probably the result of some early, probably vascular, lesion, the effect of which was to produce a small area of unstable cells in that particular region. Here was a case characterized by recurrent convulsions of a particular kind, only differing from other cases of so-called idiopathic epilepsy in the character of the aura which preceded a fit. We know that in some of these cases the convulsion is associated with a structural change in a certain part of the brain. It is only reasonable to conclude that in all of them this same area is unstable—the cause of the instability in many is not proved—but the presumption is that in all the cause is a structural derangement.

There is another class of cases in which the convulsion is preceded by a visual aura. In some of these the aura is a somewhat elaborate one—a little woman in a red cape or some equally definite vision. In many the visual sensation preceding a fit is a simple one of flashes of light, and this causes the convulsion. In one case, which I have related elsewhere, the fits were left-sided, preceded by an indefinite disturbance of vision. These fits had come on rather suddenly and unexpectedly in an old lady sent to me by Mr. Fisher, and they were associated with definite homonymous hemianopia. The fits gradually ceased, the hemianopia persisting but gradually and completely disappearing. This lady made a complete recovery, and remained well for several years. In such a case one is justified in assuming that there was some vascular lesion—in the occipital cortex—which was at first irritative, but when the irritability of the cortex had subsided or been controlled resulted in temporary interference with the functions of the area in the cortex subserving the fields of vision of the opposite side. Such a case suggests that in cases with similar visual phenomena associated with fits the fits are due to some disturbance in the same area, and the fact that the convulsions are recurrent merely shows that the irritation is a persistent one, and not transitory, as in the case just related.

There is another class of cases that have to be considered—those, namely, in which attacks may have been present for years, associated with convulsion and loss of consciousness, but yet in which no sign of gross disease has been discoverable. I have elsewhere related two cases of this nature—one a patient who had been attending at the National Hospital, Queen Square, for seventeen years suffering from recurrent convulsions, but who unexpectedly developed headache, and was found to have optic neuritis. This patient died, and was found to have a large cerebral tumour. Another patient was under my own care, and had been attending for four years on account of occasional convulsion with loss of consciousness. He had no headache and no optic neuritis, and his convulsions were few in number under treatment; but he suddenly found himself suffering from severe headache, was found to have optic neuritis, and the headaches became so severe that decompression was undertaken with the hope of relieving him. There was intense intracranial pressure, and he died after a few weeks, and a large growth was found in one hemisphere. These two cases are, I believe, examples of a group—not perhaps a very large one—but they illustrate the thesis, so far at least as such a group is concerned, that such cases—apparently for years cases of so-called idiopathic epilepsy—are really cases in which early slight structural changes are almost certainly the cause of the fits.

It is well known to all who are interested in cases of recurrent convulsion, and who see many patients suffering from these, that there is a large class of cases in which the fits occur only during the night, so it is said, and these cases are named "nocturnal epilepsy." I think most observers will agree with me that it is not the time of day which determines the onset of convulsion in these cases, but the condition of sleep, for it is not uncommon for a

patient who suffers from such convulsions to have a fit during the day if he happens to fall asleep. So that it is sleep that really determines the attack, and the presumption is that it is some condition of nutrition or circulation associated with sleep which gives rise in certain cells to discharge which results in a convulsion. What the actual condition is we need not at present inquire. It is sufficient for our present purpose to note the fact.

In another class of cases the fits always occur in the early morning while the patient is dressing. In one case the fits only occurred if the patient had an early cold bath, and always occurred in the bathroom. In such a case it would seem as if the change of posture from the recumbent during the night to the upright in the early morning was the determining cause, and it seems natural to presume that the accompanying modification of the circulation was sufficient to give rise to the conditions determining a discharge in unstable cells.

Such considerations as those I have set out and the study of cases of a nature similar to those I have mentioned, seem to me to indicate clearly that epilepsy should not be regarded as a disease but as a symptom. The convulsions of what is called epilepsy are not in their manifestations to be distinguished from the convulsions of uraemia or from those occurring with heart-block and in other conditions. It is only the discovery of associated conditions which reveals the true nature of the convulsions, and the more one sees of these convulsions in what is called ordinary epilepsy the more is one driven to the acceptance of Hughlings Jackson's dictum that "there is no such thing as a case of ordinary epilepsy."

Each case of recurring convulsion must be studied by itself. The origin of the convulsions, their nature, the march of the discharge, and especially any premonition or "warning," must be most carefully considered. By such study the cause of the convulsions is most likely to be revealed, and if this is disclosed, treatment, either surgical or medical, may be undertaken with some hope of success.

REFERENCES.

¹ *Brain*, vol. xliii, p. 1. ² *Med. Times and Gazette*, October 14th 1874. ³ *Ibid.* ⁴ *Brain*, vol. xxi, p. 580.

An Address

ON

THE HOUR-GLASS STOMACH.*

(With Special Plate.)

BY

C. THURSTAN HOLLAND, M.R.C.S., ETC.,
LECTURER ON RADIOLOGY, UNIVERSITY OF LIVERPOOL.

A DESCRIPTION of this well-known condition—hour-glass stomach—is hardly necessary, and in its typical form the *x*-ray picture is dramatic to a degree (Fig. 1). The picture of such a typical condition, after a test barium meal, shows the upper sac or cardiac end full of the food, and the lower end of this shadow has a clear cut margin, which as a rule comes down below the level of the narrowed outlet. At the site of the outlet on the lesser curvature is the ulcer cavity, with its lower part full of the food and with a gas bubble above it. A narrow stream of food passes downwards into the lower sac. This lower sac is half filled or more than half filled with food, and in this lower part, as watched on the *x*-ray screen, normal stomach contractions are seen and food going through the pylorus. This is the typical picture, but its *x*-ray varieties are very numerous, and scarcely any two cases are exactly alike in all their details. I have a record of 151 cases in which radiography showed an hour-glass condition of the stomach following on a test meal. An analysis of these cases brings out certain facts and shows certain fallacies and the possibilities of errors. The many variations which occur will depend upon, for the most part:

1. The size of the upper sac.
2. The size of the constriction.
3. Whether or not an actual ulcer cavity exists and fills up with food, and, if so, its shape and size, and whether there are adhesions to neighbouring organs and tissues.

* Given before the Manchester Medical Society, November 1920.



FIG. 1.—Typical hour-glass constriction from ulcer of perforating type on lesser curvature.



FIG. 2.—Hour glass stomach, small and non-adherent ulcer on lesser curvature. Tight constriction. Eight hours after meal.



FIG. 3.—Hour-glass constriction. Perforating ulcer. Definite constriction with large opening.



FIG. 4.—Hour-glass constriction and ulcer cavity. Immediately after meal, no food in lower sac. Coin on umbilicus.



FIG. 5.—Hour-glass constriction. Ulcer cavity full. Food in constriction. Traces of former meal in descending colon.



FIG. 6.—Five hours after meal. Shows upper sac, ulcer cavity, and a trace of food in the lower sac. Extremely tight constriction; no food entered lower sac until five hours after meal.



FIG. 7. Simulation of hour-glass constriction by pressure from gas-distended colon.



FIG. 8.—A real hour-glass constriction from ulcer on lesser curvature masked by pressure from gas-distended colon.



FIG. 9.—Spasmodic hour-glass constriction in a male. The spasm was permanent during a long examination, repeated at intervals. Compare Fig. 10.



FIG. 10.—Second examination. Same case as Fig. 9. Spasm not present.



FIG. 11.—Early hour-glass constriction (true) from small ulcer on lesser curvature. The ulcer had previously perforated, and the patient had been operated upon.



FIG. 12.—Hour-glass constriction in a woman with typical history. At operation considered to be malignant.

4. The condition of the lower sac.
 5. The presence of pyloric obstruction in addition.
 6. The presence of adhesions generally.
- (See Figs. 2, 3, 4, 5, 6.)

FALLACIES AND POSSIBLE ERRORS.

If the definite typical appearances are seen no possibility of error presents itself, and the diagnosis is certain. In less typical cases, however, there are certain possibilities of error which must be reckoned with and guarded against. I will allude to a few of the more common possibilities.

1. *Gastroploosis*.—In this condition the stomach may be much elongated; food on entering collects in the cardiac end—extends downwards in a straight or more or less thin line, and then fills up the lower portion of the stomach. The appearance of an hour-glass constriction is thus simulated by the drawing out, and so drawing together, of the central portion of the stomach surfaces. However, no error of diagnosis should arise in this condition, since (1) the pressing up of the food from the lower part by the hand when viewed on the screen, and (2) the examination of the patient in the lying down position, will at once obviate any possibility of making a mistake.

2. *Malignant disease* will not infrequently give rise to appearances simulating hour-glass constriction from old simple ulcer; but as a rule this disease causes other alterations in the shape of the shadows which will at once give rise to suspicion. Additionally the history of the case—the more rapid onset of symptoms—rapid loss of weight, and so on will indicate the real nature of the case.

3. *Pressure from Distended Large Bowel*.—A large collection of gas in the splenic flexure or its neighbourhood pressing into the greater curvature of the stomach will occasionally (1) cause the food shadow to simulate an hour-glass constriction, or (2) may mask a real hour-glass stomach. If this gaseous distension—easily recognized on an x-ray plate—is seen, the bowel should be again cleared out and a second examination made. This, and the screen appearances seen on pressing food upwards from the lower part of the stomach, easily leads to the differentiation. (Figs. 7 and 8)

4. *A Small Ulcer on the Lesser Curvature and Spasm*.—These may be considered together. The former may set up spasmodic contraction, or spasmodic contraction may be present alone without any definite stomach lesion. In the latter case it is as a rule associated with bad teeth, the appendix, gall-bladder trouble, duodenal mischief, or more remotely the pancreas. These spasmodic contractions are always atypical. They differ entirely from the appearances seen in the typical case described. Both causes give rise to a definite drawing in of the greater curvature, which, at any rate for a time, will sharply divide the stomach shadow into two well-marked portions—an upper and a lower sac. (Figs. 9 and 10.)

Sometimes a true hour-glass constriction will give rise to the same x-ray appearance and take this form of a sharp drawing in of the greater curvature on quite a small area, and it is this true hour-glass stomach which has to be differentiated from the pseudo-type. (Fig. 11.)

To do this, and when this appearance is seen, very great care must be taken. Sometimes massage of the stomach will relax a spasm and clear up the diagnosis. Sometimes pressing the food in the lower part upwards will open a spasm up and prove that the constriction is temporary. If any further doubt exists, a second test meal on a future date may show the absence of any constriction. Examination in the lying-down position, the administration of belladonna, and so on, may be of help. At the same time, if we have to deal with an ulcer of the stomach which gives rise to spasm that simulates a true hour-glass constriction, then the results as regards the symptoms of the patient and the treatment required will in reality be the same. The obstruction is there and potential, whether it be due to spasm or a definite cicatricial narrowing. I emphasize the point—when an ulcer is actually present—if the spasm is due to reflex causes then its effect on symptoms will vary according to whether it is present or not, and of course no operation on the stomach itself is indicated.

SEX OCCURRENCE.

It is a very remarkable fact that—at any rate, in my experience—true hour-glass constriction from old ulcer

occurs with far greater frequency in females than in males. In my whole series of 151 cases it occurred in females in 123 cases and in males in 23, but many of the males on analysis should not be classified as hour-glass constrictions of the stomach, due to simple ulcer—a point I shall refer to later on—and in a few of the females also this is the case. This means that the total number of true cases is less than 151.

It is a very curious point—I cannot offer any likely suggestions as to its cause—that, taking out all those cases in which there can be no doubt about the condition—namely, those cases of hour-glass contraction undoubtedly due to simple, as contrasted with those due to malignant, disease—and the huge majority of these are in females. This form in males is seen so infrequently that it may almost be said to be rare. Perhaps there may be some connexion in the wearing of and pressure from corsets, but I am not very satisfied with this as an explanation.

Analysing the males in more detail, I find that—
1. Although nine of them presented an hour-glass appearance, either clinically, under the x-rays, or at operation, or by all three methods, they were in reality cases of definite malignant disease. In all these cases the history—and I take it that this is a point of great importance—was a very short one, extending over months only.

2. Five were cases in which a gastro-enterostomy had been done some years previously, and these appeared to be due to the late effects of the gastro-enterostomy.

3. One followed on a very severe abdominal crush. Therefore only 8 out of the 23 males can be classified as typical hour-glass stomach caused by simple ulcer—and of these 5 were proved by a later operation. The history of these cases was the same as that in the females—the salient point being that symptoms had been present over a number of years, extending from a few years up to, in one case, twenty years.

As a considerable number of the cases occurred during the war, complete records are unobtainable, but I have the records of 73 operations, and it seems to me that this number is enough to establish the important points.

In two of these cases only (both females) was it decided by the surgeon at the operation that there was malignant disease, and they were closed up without anything being done. (Fig. 12.)

In two cases (Mr. Thomas) at the operation enlarged glands were present, and the cases on the table were considered to be probably malignant. In both the operation was proceeded with, and a removed gland was later reported on as being "simple." The after-history of one case is not known; the other is known to have been alive and in good health six years later.

In the remaining 69 cases, at the operation nothing was found to give rise to any suspicion of malignant disease. Many—again I regret that I cannot supply exact figures—have been seen again so long afterwards that malignant disease was out of the question. I have not any record that it is known that in a single case any later suspicions of malignant disease have arisen.

Referring in detail to a few of the more interesting cases which came under observation: In one at the operation a constriction two to three inches long was found; there was no evidence of any old ulcer except some very slight cicatricial tissue along the lesser curvature. This was a female, aged 31 years, with a history of attacks of pain and vomiting for ten years. There were no adhesions; the food came away from the upper sac from its lowest point in a thin stream corresponding to the size of the constriction, which hardly admitted a small probe. This is possibly a case of congenital hour-glass stomach. A second case showed two distinct ulcer cavities on the lesser curvature. Another case showed all the food in what was obviously the upper, cardiac, end of the stomach; a thin stream tended to percolate downwards; no ulcer cavity and no lower sac was made out. The history was that eight weeks previously she had swallowed a wineglassful of oxalic acid; no doubt the lower part of the stomach had been practically destroyed. A fourth case must be one of the rarest possible occurrence: a woman of 40 years of age, the usual prolonged history of digestive disturbances, but also associated with acute colic attacks in the left abdomen just below the costal margin. It was discovered that she had transposition of viscera, which an x-ray examination showed to be complete—the stomach was on

the right side and the colon transposed. She had a typical hour-glass constriction from an ulcer on the lesser curvature.

At the subsequent operation Mr. Kelly confirmed the x-ray findings absolutely, but he also found a collection of gall stones in a gall bladder on the left side. It is unfortunate that we had not examined her for gall stones—they might have shown. The combination of transposition of the viscera, *plus* hour-glass stomach from ulcer, and *plus* gall stones, must be one of the rarest pathological conditions ever reported.

FREQUENCY OF THIS CONDITION.

It is obvious from the number of cases I alone can report that it is a comparatively common condition—151 cases spread over a period of ten years in the x-ray department of one hospital, in which only in patients are examined as regards the stomach, prove this. Before the days of x-rays it was looked upon as comparatively rare.

DIAGNOSIS.

The exact demonstration of this condition must be looked upon as one of the many triumphs of radiography—a triumph almost, if not quite, as fine as the demonstration of kidney and ureter stones. It is not too much to say that the accurate diagnosis is entirely one of radiography, and a consideration of the symptoms, etc., and their bearing on the case, prove this to the hilt. At the same time, of course, too much must not be expected by the surgeon, and in many points of detail it may fail to indicate certain features found at operation.

If we take into consideration the main features of a case, the difficulty—or even the impossibility—of accurate clinical diagnosis becomes evident. In its classical form you have a stomach with an ulcer of long standing somewhere about its middle, and usually on the lesser curvature. This ulcer is frequently of the slow penetrative type, and it becomes adherent to liver, pancreas, or other neighbouring structures. As a result of cicatrization the stomach, at the site of its occurrence, is so narrowed that there is a stenosis, and the food passes through the stenosed portion with more or less difficulty, according to the amount of the stenosis, or according to the amount of the stenosis *plus* some additional spasm. The latter—spasm—is of purely secondary consideration, as, if it is present, its effective action is precisely the same as a permanent cicatricial stenosis. Now, if you have an ulcer at or near the pylorus causing pyloric constriction, exactly the same potentials are present, except that the food block in the latter condition is at the pylorus instead of in the body of the stomach, and the only essential difference is the passage of the food from the stomach into the bowel instead of from one part of the stomach into the other.

The point is that the ulcer will give rise to the same symptoms in whichever place it occurs if it produces a stenosis, and you will get precisely the same history from the patient—namely, a very long history of attacks of indigestion usually associated with pain after food relieved by the vomiting of food. Sometimes there is vomiting of blood—we have a record of this in 51 of the cases only. The attacks get worse and worse, the intervals between are less and less free from indigestion, and then an attack which persists for a long time without relief, often with considerable loss of weight—due to malnutrition and inability to take food—and the patient is finally x-rayed and the diagnosis made clear.

The history, the physical signs, the condition of the patient, will not, in the vast majority of the cases, distinguish between pyloric stenosis from ulcer and the hour-glass contraction from ulcer.

We used to hear much of the importance of gurgling on palpation—caused by pressing the fluid contents from one sac to the other—and of obtaining sour and stinking stomach contents by means of washing out, and so on, and it was said that these were diagnostic signs. To my mind they are of little or no importance, and they will not be obtained in the huge majority of the cases, but only in those cases in which hour-glass constriction and pyloric stenosis are present in the same case.

It is rare to find that the upper sac does not (1) allow its contents to pass on even if slowly, and it often empties quite rapidly, or (2) that it will eject its contents after an interval by vomiting. It is also rare to find pyloric

stenosis associated with hour-glass stomach, although I have seen this on occasion, and when it does occur it can almost always be determined by the x-ray examination.

I say, therefore, that the clinical diagnosis is always one of extreme difficulty, and as a rule one can go even further and say that it is practically impossible. The diagnosis is an x-ray one, and, always admitting limitations as to detail, it is extraordinarily accurate.

I have taken a note as to the provisional diagnoses entered on the papers which are sent to the x-ray department when an x-ray examination is asked for. They include dilated stomach, pyloric stenosis, gastric spasm, gastric ulcer, malignant disease, oesophageal stricture, visceroptosis, intestinal obstruction, and, lastly, "cause of symptoms" and "no diagnosis"—the latter is undoubtedly the safest. In only five cases of the whole series has hour-glass been mentioned on the papers sent with patients to the x-ray department and the diagnosis been confirmed by the x-ray examination. On the other hand, when first these cases began to turn up somewhat frequently in the x-ray department, we got a number of papers marked "hour-glass stomach," and in practically none of these was the condition found.

I am not making these statements in order to criticize in any way the ability of many accomplished physicians and diagnosticians, but merely to emphasize my point—namely, that the exact diagnosis is almost an impossibility, and that the distinction between hour-glass contraction and pyloric stenosis cannot as a rule be made.

Simple Ulcer and Carcinoma.

The final point I wish to raise is the bearing of these records on the much vexed question of the cause of gastric carcinoma and their bearing on the probability of simple ulcer being a frequent predisposing cause of stomach cancer. It must be, of course, understood that I am speaking entirely from the limited experience of the x-ray department and the impressions which the x-ray examinations have made.*

Examination of the records of 151 cases of hour-glass contraction, in which it may be taken that the large majority were caused by gastric ulcer, yields the following results:

We must eliminate cases definitely proved before operation to be due to causes which do not come within the scope of this paper; we must eliminate also 9 of the male cases in which, although they presented an hour-glass appearance, the diagnosis was one of malignant disease, and in which the histories were so short that there was no reason whatever for supposing them to be cases of long standing; they were obviously recent malignant disease with no previous symptoms. We come then to this: That we have some 120 females and 8 males in whom an hour-glass contraction existed and in whom the history extended over years, and of these cases 73 females and 5 males can be recorded with their operative findings. Five of the females had a history of less than one year; all the males and the rest of the females had histories of anything from two to thirty years, the longer histories largely predominating.

In these cases, as I have said before, the typical history is repeated attacks of acute indigestion *plus* pain and *plus* vomiting, and in less than half a history of haematemesis; a long history of gastric ulcer, mostly of a type in which there is obviously the greatest possible amount of local irritation due to a chronic ulcer over which food is constantly passing, and in many cases an ulcer cavity adherent to, and its walls partly made up of, neighbouring tissues. If ulcer is the usual predisposing cause of gastric cancer, then surely this is the very type of case in which it should occur frequently. Yet what do we find? In 128 cases (120 females and 8 males) only one female and two males were proved to have cancer, and in all 73 operations recorded, and with 3 on the operating table thought to be malignant, but whom the later history or the pathological report proved them to be not.

Again, and from the x-ray point of view, we see a large number of huge, dilated atonic stomachs due to pyloric stenosis, and without being able to give you the actual figures, I am sure that in our department they are equally frequent in men and women. The history is again one of many years' duration; the cause is practically always pyloric ulcer. So few of these are afterwards reported as

* See *Liverpool Medico-Chirurgical Journal*, January, 1914, p. 107.

showing any evidence of malignant disease that, although in an occasional case malignant disease is reported as having been found at the operation, it is so rarely that I have come to look upon these cases as so certainly non-malignant as to warrant an optimistic pre-operative prognosis.

On the other hand, an x-ray experience of the malignant stomach is that it is far more frequently seen in males; that on going into the history carefully, the very large majority state that the symptoms have been present for a matter of a few months only; and that never in their lives have they had any "indigestion" before this attack. There is nothing in the history to suggest in any way a pre-existing ulcer. I say that this is the common history, and that only a comparatively few relate a long-continued history of intermittent attacks of digestive disturbance.

There are also other facts bearing on this question. Duodenal ulcers are extremely common; they are continually irritated; they are rarely malignant. Cancer of the oesophagus is so common that I have seen literally hundreds of cases in the x-ray department. The symptoms are sudden and the history almost invariably that of a few months at the most—nothing to suggest previous ulcer.

These facts have produced a very distinct impression and raised very great doubts in one's mind that gastric ulcer is a common antecedent to malignant disease of the stomach. I suggest that these x-ray facts will require a lot of explanation before such a cause for cancer of the stomach can be accepted in the vast majority of cases.

SUMMARY.

1. Hour-glass contraction from simple ulcer is a comparatively common condition—frequent in females, rare in males.
2. Its symptomatic history is a long one.
3. It is almost entirely an x-ray diagnosis.
4. It rarely ends in malignant disease—especially in females.
5. An hour-glass condition is found in a few cases, mostly in males, and with a short history, and which is caused by malignant disease. Its x-ray appearances generally differ considerably from those seen in the non-malignant type, and are suggestive.
6. The experiences of a large x-ray department are strongly opposed to the theory that it is usual for cancer of the stomach to be preceded by a simple ulcer.

MESSAGE OF THE HEART AND RESUSCITATION.

BY

J. A. GUNN, M.D., D.Sc.,

PROFESSOR OF PHARMACOLOGY IN THE UNIVERSITY OF OXFORD.

In a paper published in this JOURNAL (November 6th, 1920) Mr. W. E. Fisher describes cases of "Resuscitation in Death under Anaesthesia," and in regard to cardiac massage he says that "it will be of great help if an understanding of the processes concerned is quickened by a clear pronouncement by physiologists, to whom we must look for guidance and more definite directions." I feel sure that he is not aware of a paper published in 1915¹ by P. A. Martin and myself, in which we attempted to give clearer directions for performing cardiac massage than had hitherto been done, and anticipated some of the observations that he has made on the human heart. Since this paper has escaped the attention of others who have subsequently written upon the subject of cardiac massage—as is almost inevitable with the multiplicity of medical journals—I think one may be excused for recapitulating, in a journal more accessible to clinicians, some of the results there recorded, the more so as I may take this opportunity of adding some other observations on the subject of resuscitation based upon unpublished experiments.

I may first state part of the conclusions arrived at by Martin and myself.

"In performing massage of the arrested heart with a view to reviving the spontaneous contractions, the following points are of importance:

"Compression should be gradual and relaxation abrupt. The rate of compression should be at most less than half the normal

heart rate. Massage should be regularly interrupted at short intervals for a few seconds to allow the spontaneous beats to develop. When the heart is arrested, massage, properly performed, acts both as an artificial circulation and as a mechanical stimulus to the heart muscle.

"Massage can be performed in the following ways, arranged in order of efficacy: (1) By direct compression of the heart through an opening in the thoracic wall; (2) by compression of the heart above the diaphragm through an opening in the abdominal wall; (3) by simple compression of the abdomen; (4) by simple compression of the thorax.

"Direct thoracic massage combined with intrapericardial injection of adrenaline can revive the heart in practically any case of chloroform poisoning in the rabbit, even though the treatment be not begun until fifteen minutes or more after the heart has completely ceased to beat.

"In about 70 per cent. of cases recovery can be obtained if treatment is commenced ten minutes after arrest of the heart by the following procedure: artificial respiration through a tube in the trachea; intrapericardial injection of adrenaline; massage through an opening in the abdomen. If, when the heart has been started, the blood pressure continues low and the heart beats remain (chiefly as a consequence of this) feeble, speedy and permanent improvement of the heart and blood pressure can be obtained by intravenous injection of either adrenaline or pituitrin.

"Treatment on these lines is suggested for cardiac arrest in the human subject, occurring either in chloroform poisoning or in other conditions in which general recovery might be anticipated to result from resuscitation of the heart."

Before the publication of our paper the expression "massage of the heart" had been used as if the manner of performing it were indifferent, but we found experimentally that attention to points of detail may make all the difference between success and failure in difficult cases of resuscitation of the arrested heart. The grounds for certain of the conclusions given above may therefore be of value.

One question of the first importance is this, that "rhythmic compression of the heart effects in the first place an artificial circulation; it produces movement of the blood in the vessels to an extent which depends upon the way in which it is done." In animal experiments such as we performed an indication of the mechanical efficiency of massage in effecting a circulation of the blood could be obtained (the blood pressure being at zero) by the amplitude of the wave of blood propelled into the aorta by each compression of the heart. A record of this wave was obtained by a mercury manometer connected with a carotid artery. But a more direct proof of the fact that massage of the heart acts, to begin with, as a substitute for the spontaneously beating heart in causing a circulation of the blood was obtained in the following way: A solution of a blue-green dye "was injected into the cavity of the right ventricle of an arrested heart. Cardiac massage was then performed, and after a few compressions the blue-green colour appeared first in the lungs and then in the carotid artery. Massage had therefore propelled the blood from the right ventricle through the lungs and left side of the heart into the systemic circulation."

Fisher describes this action of massage as "an influence upon the circulation that I have not seen previously observed." It is all the more interesting that he has described independent observations on the same phenomenon but judged by different effects—namely, flushing of the skin and rise of intraocular tension occurring as the result of massage prior to spontaneous beating of the heart.

This action of massage has an importance not merely academic. I have started the heart beating an hour after it has been arrested by chloroform. I have perfused the excised heart of a stillborn child four hours after the child was born, and started the heart beating again. The difficulty is not so much in starting the heart, though this may of course be difficult, but in starting the heart sufficiently soon that the other tissues have not meantime been rendered incapable of recovery by stoppage of the circulation. So far as is known, it is the cells of the central nervous system that are most susceptible to stoppage of the circulation, so that, from the practical point of view, the circulation must be started before the cells of the central nervous system are irretrievably damaged. The current opinion is that after complete stoppage of the circulation for about fifteen minutes the cortical cells cannot be revived. While my own experiments have also pointed to this conclusion, I am not convinced that it is true; and, for reasons that I need not enter into here, I should not be surprised if some day it were shown that even the cortical cells can survive arrest of the circulation for a much longer period. What is

known is that they are difficult to revive. It is not proved that they are dead.

Many other tissues can withstand absence of circulation for a long period. Thus I have revived the movements of the isolated guinea-pig's uterus after seven days' keeping in cold storage, and the human Fallopian tube after thirty hours; ² the rabbit's intestine after five days; ³ the human vermiform appendix after thirty six hours; ⁴ and the heart after twenty-four hours ⁵ or longer. At higher temperatures they do not survive so long, ³ but even at temperatures between ordinary room temperature and body temperature they survive for hours. In tissues such as these there need be no anxiety in regard to the possibility of restoring their functioning capacity after prolonged arrest of the circulation. The liver requires further investigation.

In the meantime the question of resuscitation may be taken to depend upon how long the cortical cells can survive arrest of the circulation. And it is in this connexion that there arises the importance of the capacity of cardiac massage to act as an artificial circulation. For the difference between complete and incomplete stoppage of the circulation is enormous when gauged by the effects on the cells of the central nervous system. It has been found, for example, that when an attempt has been made to occlude the cerebral circulation by clamping the vessels to the brain, much more prolonged survival of these cells may occur if a mere trickle of blood through a small vessel be intentionally or accidentally left. Other phenomena point to the same conclusion. For example, in hibernating animals both circulation and respiration are reduced to a very low level for months, and yet the animals revive rapidly and completely when the circulation and temperature, etc., are restored. Now the experiments by Martin and myself are confirmed by Fisher's observations, and it can be taken as proved that massage of an arrested heart, if properly performed, can act as a fairly effective mechanical means of conducting an actual circulation of the blood. This being so, it is more than probable that, for the purpose of deciding whether the cells of the central nervous system are capable of complete restoration or not, the time can be calculated not as from the start of spontaneous heart beats but as from the time of beginning massage. This is a point of fundamental importance, and puts a different and more hopeful complexion upon the whole question of resuscitation.

Method and Rate of Compressing the Heart.

In the paper already quoted we said further:

"Judged merely from the point of view of its acting as an artificial circulation, massage would be most efficacious when carried out uninterruptedly, because the maximum amount of circulation of blood would thereby be accomplished, and therefore the speediest elimination of chloroform. However, we have repeatedly found that this is not the case, the reason being that this procedure fails to take due cognizance of the second function of massage—that, namely, of acting as a mechanical stimulus to the heart itself. The latter is the real object aimed at in performing massage; and, though a mechanical circulation may be a necessary preliminary to obtaining conditions under which the heart can resume its action, it is clear that, even from the point of view of circulating the blood, cardiac massage is an inadequate substitute for the beating heart. It is essential that this mechanical stimulation should be applied in such a way as most effectively to encourage the spontaneous contractions of the heart. This is not attained by continuous massage. It has been found, for example, that massage which has started feeble spontaneous beats, if continued without intermission, may cause the beats to disappear again. No doubt it is possible to overdo mechanical stimulation, and continuous massage does not give the heart a sufficient opportunity of developing spontaneous beating. We have found, as a result of a large number of experiments, that when the feeblest beats have begun, even beats which fail to move the manometer, it is better to cease massage for some seconds so as to allow them to develop, and to apply short periods of massage intermittently, when it is usually found that perhaps by the third or fourth series the heart suddenly regains a normal rhythm and the blood pressure rises rapidly."¹

The most effective rate of compression is much slower than the normal heart rate, for two reasons: One is that a slow rate is necessary to allow complete filling of the ventricles, and the other that it is a subnormal rate of beat that one is attempting to elicit—namely, the rate at which the arrested heart will begin beating again. The advantage of intermitting massage had not previously been suggested. Possibly if attention were paid to this,

attempts to revive the human heart would be more successful.

Action of Adrenalin.

There is no known drug comparable with adrenalin in efficacy to start an arrested heart or to antagonize the action of chloroform. I have shown that adrenalin can start beats in a perfused mammalian heart—for example, when kept for twenty-four hours—when mere perfusion has failed. When the isolated mammalian heart is perfused with concentrations of chloroform or chloral which almost or even completely arrest the heart, the addition of adrenalin to the chloroform or chloral solution is able to restore the heart beats to their normal vigour.⁵ This is an extraordinary effect. It is not an antagonism of the type, for example, of atropine *versus* pilocarpine. For chloroform and chloral depress the heart muscle, and in the experiments referred to adrenalin is able to antagonize a concentration of chloroform or chloral which practically or completely stops the heart while the latter solution is still passing through the heart, and its action therefore getting deeper. I do not think that this power of adrenalin—which is equivalent to stimulation of the sympathetic nerve of the heart—to antagonize a muscular paralysis has been sufficiently realized.

When the circulation is arrested in the intact animal, the difficulty, of course, is to get the adrenalin at the heart, even intravenous injection being practically useless when the heart has stopped. One method is to inject adrenalin into the pericardial sac before beginning massage, but this might be difficult to one who has had no experience of giving such an injection, and I have myself no experience of performing it in man.

Seeing, however, that massage causes an artificial circulation, adrenalin will reach the heart in time from a vein if massage be continued. This will occur sooner the nearer to the heart the vein is into which the adrenalin is injected. If it were injected into an external jugular vein it would very probably reach the arrested heart after a few effective compressions by massage.

One point in regard to adrenalin which may cause confusion is that a combination of adrenalin and chloroform is, as has been pointed out by Levy, more likely to produce fibrillation of the heart than chloroform alone. This, however, refers only to cardiac arrest from chloroform occurring in the initial stages of anaesthesia. This danger does not occur, in my opinion, in cardiac arrest occurring at other times.

There is another point in regard to the action of adrenalin about which there seems to be a good deal of misconception, and that is as to the permanence of its effect. It is true that in the normal animal with a good blood pressure the rise of blood pressure produced by adrenalin is very transient, lasting only a few minutes. But this is not true in certain abnormal conditions of the circulation—for example, when the animal is being resuscitated after arrest of the heart. Here the blood pressure may remain low after spontaneous beats of the heart have begun. This low blood pressure is due partly to temporary paralysis of the vasomotor centre and partly to feebleness of the heart's contractions. These two effects interact on one another. This vicious circle is broken by adrenalin. The temporary rise of blood pressure provides a better blood supply to both heart and vasomotor centre, and this may be sufficient to enable both to function properly, and in these circumstances the rise of blood pressure produced by adrenalin may be permanent. I believe it may be so in other similar conditions of the circulation.

Figs. 1 and 2 are reproduced (by permission) from the paper referred to. They show the sequence of events in a difficult case of restoration of the heart after it had been arrested by chloroform, and massage begun fifteen minutes later. The effects of intermittent massage are shown and the permanent effects of adrenalin injection.

Artificial Respiration in Man.

I have taught my students for years that the time will come when every hospital will be provided with an appliance for mechanically performing artificial respiration in man. So far this prophecy has remained unfulfilled. The usual method employed in the laboratory for this purpose in the case of laboratory animals is a pump or bellows which forces air into the trachea, and so distends the

lungs. It is a method theoretically imperfect, which in practice works well and gives no trouble. I have seen it stated in physiological textbooks that this method of performing artificial respiration is inadmissible in man, but I have not seen any convincing evidence given for this statement. In the case of adults with very rigid chest walls there would be theoretical objections to it, but, with the patient in the horizontal position, very probably an excursion of the lung sufficient to give the minimum necessary aeration of blood could be obtained by that expansion of the lung allowed by little else than movement of the diaphragm. If necessary, oxygen could be used instead of

tube. It was this method that I used in resuscitation experiments on rabbits.

If the heart has stopped, for example, in the course of chloroform anaesthesia, to get the heart started again is only the beginning of resuscitation. The next thing is to get the natural respiration evoked. Now when the circulation has been stopped for several minutes, the respiration does not commence immediately upon the heart beginning to beat again. It takes time for the respiratory centre to recover. In animal experiments I have seen thirty minutes elapse between the starting of the spontaneous heart beats by massage and the beginning of

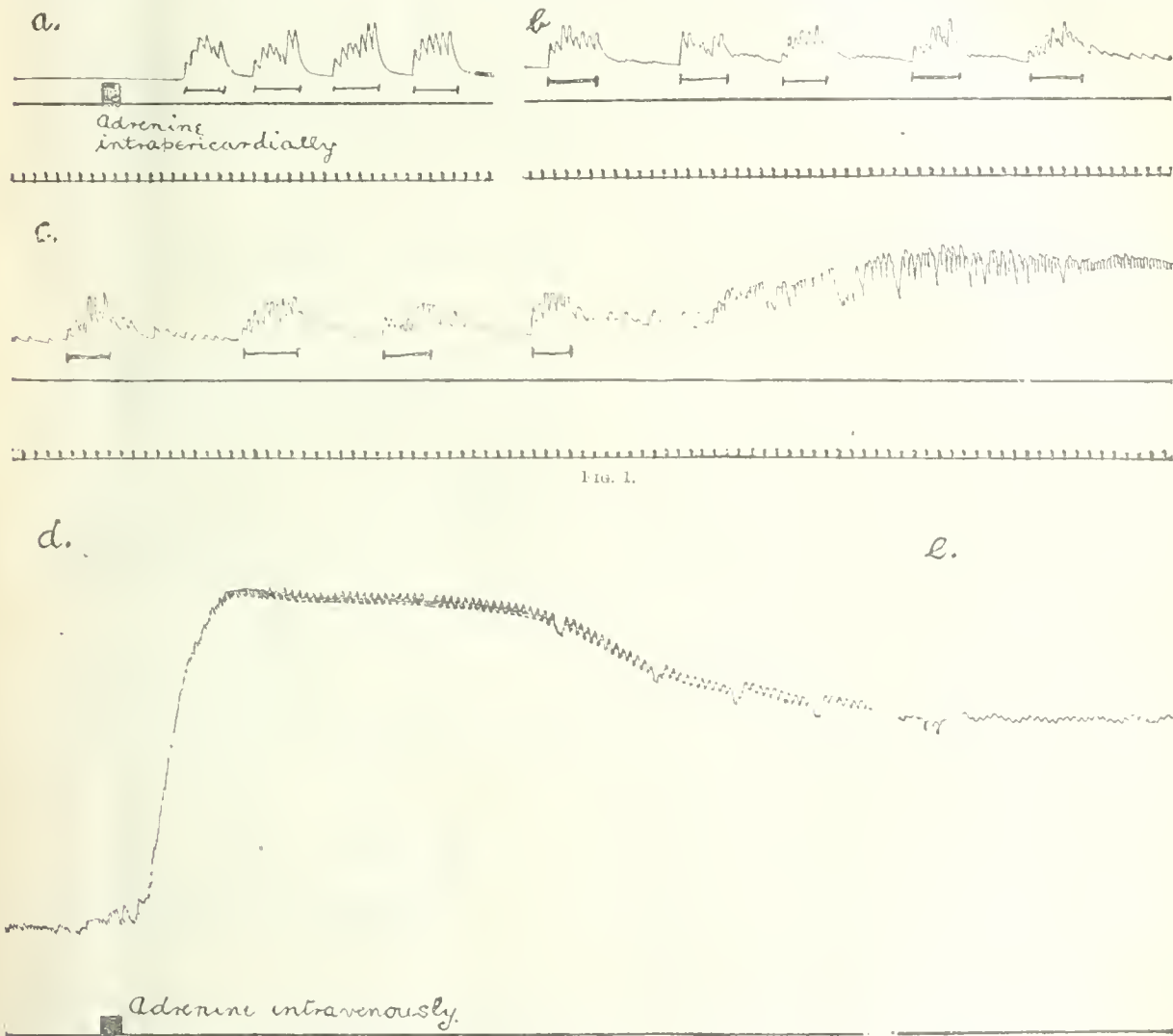

FIG. 1.

FIG. 1—Rabbit. Heart arrested by chloroform. Showing complete resuscitation, manometer record of blood pressure, and pulse wave in carotid artery. The periods of massage are marked. By the end of Fig. (b) feeble spontaneous beats had commenced, and by the end of (c) the heart was beating regularly. Blood pressure remained low. Intravenous injection of adrenaline produced an abrupt rise of pressure (d). The pressor effect was maintained (e, taken twenty minutes later).

air. But, in any case, in children the method of positive artificial respiration ought to prove just as serviceable as in animals like the dog.

Having in view the possible adoption of this method of performing artificial respiration in man in cases of resuscitation, etc., I have modified the usual technique in order to dispense with tracheotomy and the time involved in performing it. Instead of tying a short cannula into the trachea through a tracheotomy opening, a long tube is passed through the mouth and larynx down to just above the bifurcation of the bronchi. This tube should be of about two-thirds of the internal diameter of the trachea. When intermittent positive artificial respiration is used—for example, by a Brodie's pump—each blast distends the lung and the air escapes along the outside of the tracheal

natural respiration. More usually it is between five and ten minutes. If artificial respiration is not carried on during this interval, the heart will of course fail again from asphyxia. It is therefore imperative that artificial respiration should be kept up after the heart has begun beating again and until normal respiration begins.

There is no question that the problem of resuscitation is enormously facilitated by the employment of mechanical artificial respiration. With an apparatus such as Brodie's respiration pump with its modern improvements, whereby the amount of air pumped and the rate of pumping can be altered at will, and the air warmed or charged with a volatile anaesthetic if desired, one has no anxiety with regard to the respiration. Artificial respiration can be intermitted and restarted in a moment. If it be found

possible to use this method in man—and I shall be convinced of the impossibility only when I see it fail—there would be a great increase in the percentage of recoveries after attempted resuscitation in man.

Other Factors requiring Attention in Resuscitation.

In experiments which I performed in the latter part of 1915 I found that there were certain other points which have an important influence on the speed and completeness of resuscitation, and which I may take this opportunity of pointing out.

In the first place, when natural respiration begins (after arrest of the heart, massage, etc.) the respirations to begin with are slow. When the tube through which artificial respiration has been performed is allowed to remain in the trachea they tend to continue slow. I found on looking over the data of experiments that when this tube was removed from the trachea there was invariably a sudden and pronounced increase in the rate of respiration. This, no doubt, was partly due to increase in the available lumen of the trachea consequent upon the removal of the tube. But it seemed greater than could be accounted for by that alone, so that it is possible that the presence of the tube, from reflex irritation of the air passage, tends to slow the natural respiration. Whatever the theoretical explanation the practical conclusion is clear: As soon as natural respiration has become established the tracheal tube should be removed.

In the second place, there is one danger point in the course of resuscitation which I believe is of great importance and which has not to my knowledge been noted before. After considerable experience in resuscitating animals killed by chloroform, I found that I could anticipate with some confidence that I would be able to resuscitate an animal, by the methods described, to the stage that the heart beats and natural respiration were resumed. But here an unexpected difficulty arose, because I found repeatedly, but not invariably, that after the first gasp or two of natural respiration the heart, hitherto beating well, suddenly ceased beating and could not be restored even by massage. I had this experience with three rabbits in succession in one day. This was distinctly disappointing. In casting about for an explanation the only one that suggested itself—and it is not entirely satisfactory—is this: After stoppage of the circulation for several minutes the central nervous system is paralysed. The centres recover when the circulation is resumed and the blood aerated. When the respiratory centre recovers, probably other medullary centres recover somewhere about the same time. It is conceivable that when the respiratory centre commences to function the vagus centre commences at the same time or only just later, and that after its prolonged abeyance of function there is a sudden and excessive discharge of vagal impulse which stops the heart. Acting on this hypothesis, whether it be correct or not, in subsequent experiments I gave an intravenous injection of atropine to prevent vagal inhibition, and after that I did not experience this type of cardiac failure. The result may, as so often happens, have been due to an increase in skill in performing the experiments of which I was not cognisant. But in any case, seeing that atropine can do no harm, I think it would be advisable provisionally to adopt this safeguard in resuscitation in man.

Lastly, in all resuscitation experiments great care must be taken to maintain the body temperature. After stoppage of the circulation and temporary paralysis of the whole central nervous system, the animal does not easily recover its power of heat regulation.

SUMMARY.

To sum up, I would venture to lay down the following directions for resuscitation in cardiac arrest in man or animals, whether from chloroform anaesthesia or from any other condition in which cardiac arrest is "accidental."

If the heart has stopped, artificial respiration should be resorted to immediately by the usual methods. If, at the end of three or four minutes, no pulse can be felt, and especially if no heart beats can be heard on auscultation, adrenalin should be injected into an external jugular vein, by an assistant if available; if no assistant be available, I believe the gain from adrenalin more than compensates for the loss of time, provided the materials are at hand, as they ought to be. In the meantime, or subsequently,

as the case may be, the abdomen should be opened high up, one hand inserted in the opening, passed up over the left lobe of the liver, and the heart felt for above the diaphragm. The heart should then be massaged intermittently. I endorse all that Mr. Fisher says in regard to not relying upon artificial respiration alone and in regard to boldness of procedure if the heart has stopped. When it has stopped there can be no further risk. As soon as spontaneous beats of the heart, however feeble, are felt massage should be interrupted for several beats to allow the contractions to establish themselves; otherwise, continuous massage may abolish them again. The heart should then be massaged again for a short time, when the beats will probably improve. When the heart has begun beating it is safer to use too little than too much massage. The hand should not be removed from the abdomen till the heart is beating well. When the heart continues to beat regularly and strongly an intravenous injection of atropine should be given. Artificial respiration must be kept up continuously, also after the heart begins beating. After five minutes it may be interrupted to see if natural respiration will begin, but not for long. No harm is done by keeping up artificial respiration, even if it inhibits the natural respirations, whereas, on the other hand, it is not safe to interrupt artificial respiration very long, if natural respiration does not commence.

If it be found that positive artificial respiration can be used in man by, for example, a Brodie's pump of larger size than that used in the physiological laboratory, the problem of resuscitation will be greatly facilitated.

Natural respiration may be expected to begin in five to ten minutes after the heart begins to beat again, but may be delayed for thirty minutes.

During the manipulations, and afterwards if these procedures be successful, care must be taken to maintain the body temperature.

All attempts, successful or not, at resuscitation after cardiac arrest in man should in the present state of knowledge be recorded. When it is possible—and it cannot well be possible unless assistance is available—accurate notes should be kept not merely of the sequence of events, but of the actual times of occurrence.

REFERENCES.

- ¹ Gunn and Martin, *Journ. of Pharmacol. and Exper. Therapeutics*, 1915, vii, p. 31. ² Gunn, *Proc. Roy. Soc.*, 1914, lxxxvii, p. 551. ³ Gunn and Underhill, *Quart. Journ. of Exper. Physiol.*, 1911, viii, p. 275. ⁴ Gunn and Whitelocke, *Brit. Journ. of Surg.*, 1914, ii, p. 32. ⁵ Gunn, *Quart. Journ. of Physiol.*, 1913, vii, p. 75.

THE PRACTICAL GAINS OF CLINICAL CARDIOLOGY SINCE 1900.*

BY

W. GORDON, M.A., M.D., F.R.C.P.,

PHYSICIAN TO THE ROYAL DEVON AND EXETER HOSPITAL; PHYSICIAN
TO THE WEST OF ENGLAND EYE INFIRMARY.

DURING the last twenty years a great deal of interesting and valuable work has been done in medical cardiology. What I propose is briefly to summarize the practical gains which we, as clinicians, have derived from it. In so limiting my field, I am forced to exclude from it much that is interesting, as belonging to physiology rather than to medicine. But I hope that what my paper thus loses in attractiveness it may atone for by usefulness.

CARDIOLOGY IN 1900.

I need hardly remind an audience well read in the literature of twenty years ago that all the factors involved in cardiac failure were then clearly recognized; that no one called in question so obvious a truism as that the cardiac muscle was of predominant importance; or doubted the danger of such mechanical impediments as a leaking aortic orifice or a contracting mitral. No thoughtful person then referred to "back pressure" as a cause of heart failure, but only as a consequence and complication of it. Gaskell's brilliant work had shown that the heart muscle was more independent of nervous control than had previously been imagined, and Kent and His had demonstrated the path along which the normal stimuli of contraction travelled. The effects of vascular disease, in and

* Read at a meeting of the Devon and Exeter Medico-Chirurgical Society, to open a discussion, December 16th, 1920.

outside of the heart, were then fully recognized, as were also the injurious consequences of anaemia. The influence of the endocrine glands had begun to be investigated. Poisons, organic and inorganic, of bacterial or other origin, were attracting the attention they deserved. Overstress had been discussed. Malformations had been elaborately described. The infections of the endocardium were being enumerated. It was fully recognized that many irregularities of the pulse were of little consequence, and that some murmurs mattered, whilst others did not. Thus murmurs were divided into "functional" and "organic," and amongst these latter the decided differences in seriousness were carefully indicated: the minor significance of irregular pulse in childhood had not been overlooked, intermissions were usually held to need no treatment, and "delirium cordis" was regarded as a special indication for digitalis—although it must be noted that in mitral stenosis the continued administration of the drug was often found badly borne. Our excellent existing classification of cardiac diseases had been already built up and almost all our present remedies were in familiar use.

OUR GAINS SINCE.

I will divide my material into the following sections: Treatment, prognosis, diagnosis, physical signs (detached for convenience), and etiology.

TREATMENT.

Dr. Caton has added an important chapter to the subject of *preventive medicine* by showing how we may prevent many cases of incipient rheumatic endocarditis from passing into permanent valvular disease by prolonged rest in bed, the administration of sodium iodide and the application of blisters.

Dr. Arthur Goulston, by his ingenious use of *cane sugar*, has given us a valuable aid in dealing with chronic heart failure. It is noteworthy that beet sugar is without effect and that the cane sugar must not be cooked.

The intravenous use of *strophanthin* in urgent cases has been found of unmistakable value. *Theocin sodium acetate* has proved its usefulness in dropsy which has not yielded to other diuretics. Sir Lauder Brunton's insistence on the importance of *morphine* in the distressing *dyspnoea* of late heart disease has promoted its general use in that condition, and the discovery of the immediate value of its hypodermic injection in *acute pulmonary oedema* (which occasionally occurs in cardiac patients) has put a valuable weapon in our hands. In "soldier's heart" graduated *exercise* has expedited the generally slow recovery.

Strychnine has been unadvisedly discredited. Surgical shock, in which it has been rightly replaced by *pituitrin*, is a different condition from ordinary heart failure, and although there are those who prefer injections of *camphor* in cardiac breakdown, we shall do wisely if we hesitate to discard from our therapeutics a remedy which the sober judgement of competent clinicians has so long relied on.

The use of *salvarsan* in cardiac syphilis appears to have special risks and, if used at all, it should probably be given in smaller doses than ordinary.

In streptococcal endocarditis (the most frequent variety) we have learnt that whereas *anti-streptococcal* serum occasionally succeeds, streptococcal vaccines almost invariably fail. *Standardized digitalis* is a valuable advance.

Three surgical procedures require medical notice. Brauer's operation of "*cardiolysis*" is of service where a heart is gravely hampered by adhesions of the pericardium to the chest wall. *Direct massage of the heart* through the diaphragm, in cases of heart failure under operation, has been the means of restoring life. *Incision of the pericardium* seems at last to be recognized as a safer proceeding than the older paracentesis.

PROGNOSIS.

The prognosis of *cardiac syphilis* has received a good deal of attention, and would seem to be very unfavourable. Dr. Mitchell Bruce has stated that only 50 per cent. of the cases improve at all, and that 20 per cent. die within a few years. Patients with syphilitic aortic disease, he finds, generally die within a little over five years. Adler and Weber, however, believe that early treatment may cure. All authorities insist on prompt and vigorous measures.

Perhaps now that fuller means of diagnosis are at our disposal, as in the Wassermann reaction, earlier recognition may lead to a better outlook.

In 1898 a distinguished authority, whose experience was chiefly derived from a great industrial area, wrote that cases of *aortic regurgitation* had never, in his recollection, survived for fifteen years. This was so different from Devonshire experience, and from experience in other non-industrial centres, that the discrepancy suggested that possibly great local differences in general expectation of life might be showing themselves incidentally in cardiac patients. Accordingly, in 1909, I examined the proportion of the population which survived to 75 and over in all the registration districts of England. The result was remarkable. In Leeds, where the shorter survivals alluded to were observed, only 6 per cent. of the population reached those ages, in Manchester only 2 per cent., whereas in some Devonshire districts, such as Axminster and Crediton, 25 per cent. did so. Since then a number of observers have repeated the older observation of cases of aortic regurgitation surviving for twenty five and even thirty years; and a case of combined aortic and mitral regurgitation, which survived for over thirty years, had been for nearly twenty eight years under my own observation in Exeter. This fact of *local prognosis* is one which, it would suggest, needs further attention.

DIAGNOSIS.

A number of new instruments have been added to our equipment. The *sphygmomanometer*, introduced a little before 1900, has only come into general use since that time, and Dr. Batty Shaw has pointed out its value in distinguishing secondary from primary cardiac disturbance.

The *x-rays*, with or without *orthodiagraphy*, are necessarily becoming more and more a help in the examination of our cases. Especially useful have they been in establishing or correcting the diagnosis of aortic aneurysm. As I shall presently point out, they afford valuable assistance in verifying the findings of digital percussion.

Mackenzie's *polygraph* has been an important means of distinguishing—and of giving us other means to distinguish—the different varieties of pulse irregularity. To this I shall return.

Einthoven's *electrocardiograph* promises to assist in the unravelment of certain problems. As yet, however, it is difficult to see that it has proved of much practical use to the clinician.

Leyton's *differential stethoscope* may enable us to compare clinically the relative intensity of a patient's heart sounds at different periods and under different conditions.

Even the older modes of auscultation admit of revision and comparison. Thus I have recently compared the old-fashioned "single" straight wooden stethoscope with its more popular successor, the ordinary "double" or binaural flexible stethoscope, and both of them with the almost discarded method of "immediate auscultation"—that is, of listening with the ear laid directly on the chest wall with only some thin fabric intervening. I have found that whereas a slight mitral regurgitant murmur is more loudly and distinctly heard with the double stethoscope than with the single, a slight aortic regurgitant murmur which may be missed with the double stethoscope can be heard clearly with the single; also that an aortic regurgitant murmur may be occasionally inaudible to both these stethoscopes and yet be made out unmistakably by immediate auscultation. This applies to both the upright and recumbent postures.

Sir William Osler's *spots* in malignant endocarditis were, I believe, discovered within the period we are discussing.

The *oculocardic reflex*—which, by the way, may be lost in locomotor ataxy—may furnish us with a means of checking a heart rate just too rapid for exact examination.

In the absence of mitral stenosis or of recent vigorous exertion it appears to me that the presence of a *distantly heard first heart sound*—by which I mean "heard without a stethoscope at a distance greater than the length of the ordinary straight wooden stethoscope, that is, about 7 in."—is strongly suggestive of hypertyroidism.

I think there can be no doubt that whilst the importance of symptoms has been rightly insisted on for many years and directions have long been given for examining hearts

after some brief exertion, the routine care, now in general use, of inquiring into evidence of cardiac failure from the degree of exertion needed to produce distress, as also the present routine of re-examining hearts after exertion, is mainly owing to the insistent teaching of Mackenzie and his school.

PHYSICAL SIGNS.

I. On Pulse Abnormalities.

We are chiefly indebted to Sir James Mackenzie and Dr. T. Lewis for the brilliant investigation of pulse abnormalities by graphic methods. The subject is most interesting and has engaged many able workers for several years past. If one cannot admit all the clinical claims which enthusiasts have made for their scientific results, it is not that one does not recognize the general debt we owe to their skill and labour.

Total Arrhythmia.—Dr. Lewis has made the interesting discovery that this well-known accompaniment of cardiac failure is caused by fibrillation of the auricle, a condition in which the auricular fibres contract in such separate and inco-ordinate fashion that the auricle as a whole stands still. As a scientific explanation of the auricular inaction and the coincident total arrhythmia of the ventricle, this is an important piece of work. But clinically it has, so far, had very little effect. As regards diagnosis, the condition underlying it has still to be determined by other and older methods; in prognosis, a condition which may end in a few weeks, or may last for years with little apparent detriment, cannot be regarded as very helpful; whilst in treatment it is difficult to see how its recognition has affected us at all.

Heart-block.—Perhaps no chapter in cardiology is more fascinating than that which, beginning with Gaskell's researches, has included such fine work as has been done by Kent and His, Tawara, Erlanger, Keith, Mackenzie, and Lewis—to mention only a few. In the future we may hope for clinical results, such as will aid us in the prognosis and treatment of the condition evidenced by the Stokes-Adams syndrome, but at present we stand as we did.

Intermissions.—Except that the premature dwarf contractions, which our stethoscopes alone formerly detected, are now called "extra-systoles," we have made no practical progress in our knowledge of these. But it is a gain to have recognized that intermissions may be due to pauses of the whole heart or to occasional heart-block.

Paroxysmal Tachycardia.—We have learnt that one variety, due to "auricular flutter," is amenable to large doses of digitalis, which convert the flutter into auricular fibrillation, which in turn, on discontinuance of the drug, reverts to the normal rhythm. In other varieties we seem to be much where we were.

Pulsus Alternans.—This sign, originally described by Traube, has lately been assigned a most serious significance. Yet so able an observer as Sir William Broadbent wrote in 1897, "I have learnt not to attach serious importance to the regular alternation of a strong and weak beat, so long as there is no great frequency with it." Carver has lately recorded its occurrence in persons with no apparent cardiac lesion, and stated that it may disappear, leaving the patient apparently none the worse. Which view of its significance is correct?

Sinus Arrhythmia.—Here we are clearly indebted to the graphic methods. They have made precise the meaning and diagnosis of this usually harmless form of irregularity. Sinus arrhythmia is a vagal irregularity, its rhythm starting, as it normally should do, from the sino auricular node and involving the whole heart. Its pulse rate rarely exceeds 100, and more usually is as low as 60 or 50, whilst anything which quickens the pulse, such as exertion or rise of temperature, removes the arrhythmia. Atropine (which has no effect on auricular fibrillation), by its action on the vagus, removes it. With the three exceptions mentioned below it needs no treatment, not even change of habits. It is the common irregularity of childhood up to 10, a period in which premature contractions are unusual, heart-block rare, and auricular fibrillation very rare. It is less common in adults. When, as is the rule, there is an obvious relation to respiration, ordinary or deep, says Dr. Lewis, its nature is evident; a gradual waxing and waning of rate is always highly suggestive, if not conclusive. The radial beats and apex beats correspond; the heart sounds show no trace of extra-systoles. The pulse beats are full and equal in amplitude.

There are, however, three varieties in which there is no association between the pulse irregularity and phases of respiration—namely: (1) Sudden prolonged pause of the heart beat, usually with syncope—a rare condition. (2) Relatively abrupt slowing of the whole heart to 20 or 40 beats a minute with fall of blood pressure, which Lewis believes is the commonest cause of fainting attacks in adults. (3) Variation of pulse rate in phases lasting ten, fifteen, or more seconds—uncommon, sometimes following large doses of digitalis or its congeners, sometimes apart from these. All these are due to vagal influence and are removed by atropine—a valuable therapeutic indication.

It is noteworthy that Dr. Watson-Williams has observed that well marked respiratory undulations in a boy's pulse "implied, if anything, that he would make a good sportsman."

II. Influence of Respiration on Murmurs.

It has long been taught that systolic heart murmurs which are obliterated by a deeply-held breath should be suspected of being exocardial (so-called "respiratory murmurs"), that is, negligible so far as the heart is concerned. I have, however, recently found that a deep-held inspiration is capable sometimes of obliterating the soft diastolic murmur of slight aortic regurgitation in young adults. The chief significance of this lies in the doubt it casts on the present interpretation of systolic "respiratory" murmurs.

III. The Influence of Posture.

The advice to examine heart patients both erect and recumbent is old, yet it was rarely followed until recently. "Scientific" accounts of cases, twenty years ago, were constantly being published with no note of the posture at the time of observation. No ordinary textbook that I know of prior to 1906 (when I published what I believe were the first observations on the effect of posture on the normal cardiac sounds and on the normal cardiac dullness), and few since, have said a word about posture in percussion—Broadbent's book does not once allude to it! Only Dr. Blackhall-Morison, in his work on *Heart Failure* (1897), gave a figure illustrating the change in the dullness in a case of mitral disease (the first such figure, I believe, ever published), and added this admirable statement: "Whatever method be pursued in determining the dimensions of the heart by percussion, it is of the first importance that the posture of the patient should, so far as possible, be exactly the same on successive occasions when this point is under observation."

For the following additional points I have made myself responsible:

1. That the real width of the heart is most closely determinable by percussion when the patient is erect.
2. That in cases of enlarged heart the difference in the dullness produced by change of posture from the recumbent to the erect may be relatively great; three examples will suffice:

	Erect.	Recumbent.
Case A. ...	9 in.	5 in.
Case B. ...	8½ in.	4½ in.
Case C. ...	8 in.	5 in.

These show what confusion may arise from examining the patient in different positions on different occasions.

3. That this difference is chiefly due to the change in the rightward edge of dullness.

These three facts have recently been made abundantly evident by x-ray photographs, in which the lateral limits of dullness, previously percussed out in the two positions, have been marked by pieces of metal attached to the chest wall.

4. That the presystolic murmur of mitral stenosis is sometimes only audible in the erect position.

5. That the systolic murmur of aortic stenosis is sometimes only audible in the recumbent position.

6. That an accentuated and reduplicated second sound over the pulmonary artery is best heard in recumbency and that sometimes the reduplication is only evident in recumbency.

7. That the cavity of the chest is usually appreciably deeper antero-posteriorly in the upright than in the recumbent position. Dr. Blackhall-Morison's luminous remark, that a much-enlarged heart has to be considered as a form of intrathoracic tumour, leads importance to

this fact. Also, from a consideration of the differing influence of posture on the best-known heart murmurs together with this effect on chest depth, it has been possible for the first time (1902) to supply a rational explanation of the influence of posture on heart murmurs—namely, that it is due, in part to the effect of gravity on the intra-cardiac currents, and in part to the change in the chest depth. It is necessary to recall this explanation, as it has recently been misquoted.

8. That what I have called *distantly-heard heart sounds* are more distantly heard in recumbency. Thus in a case of Graves's disease, the first sound was audible 5 ft. away in the recumbent position, but only about 2 ft. away in the erect.

9. That from all the above considerations it is clear that no important cardiac case is properly examined or described in which posture is left out of account.

10. That in certain cases of *cancer*, especially cancer of the digestive organs and in their later stages, the recumbent cardiac dullness (R. C. D.) is remarkably diminished (to under 2 in., or more typically to about 1 in.), or even altogether lost. This "*cardiac sign in cancer*" I have found of great value in the diagnosis of obscure cases. In one series of fifty cases there was only 6 per cent. of error.

Another, and a very interesting effect of change of posture, is that described by Dr. Blackhall-Morison, which he considers valuable as a warning of grave heart failure. It is that the crepitations of pulmonary congestion, if heard at one lung base, can be transferred at once to the base of the other lung by turning the patient on to the opposite side from that on which they were first audible.

Dr. Batty-Shaw has used change of posture to distinguish the *pulmonary-arterial diastolic murmur*, due to high pulmonary pressure. In the erect posture this murmur, being heard alone, might be taken for the murmur of aortic regurgitation. "Recumbency will, however, change the whole picture and reveal the presence of an obstructive or of a double mitral murmur."

ETIOLOGY.

The most important etiological study has been that of the so-called "*soldier's heart*"—the "irritable heart" of Da Costa in the American Civil War—for which the late war has furnished a superabundant mass of material. In its most striking form the signs of structural heart disease are absent, but the patient is short of breath on exertion, easily exhausted, and complains of palpitation, precordial pain, giddiness, and more rarely of actual fainting; exertion, excitement, and sometimes change of posture, noduly hurry his pulse, and this hurried pulse is unduly long in returning to its normal.

In other cases there may be slight cardiac enlargement, with soft systolic murmurs, sometimes perhaps due to relative incompetence, or being sometimes "haemic" or "respiratory" in character. Now and then the syndrome may be superposed on actual structural heart disease.

At first the condition was attributed to physical overstrain, and especially the overstrain of men unaccustomed to strenuous exertion suddenly submitted to arduous military training, aggravated perhaps by excessive cigarette smoking. But as the war went on it was noticed to follow on various infective diseases, on mental shock, and on exposure to great heat of climate. Cardiac drugs were found useless, and rest was then thought to be the only remedy. The cases were, as Da Costa had recorded, exceedingly obstinate. Presently the disease appeared amongst the women undergoing anxiety at home, and its psychical aspects can be more clearly into view.

Present-day opinion may perhaps be briefly thus stated. It is a condition of neurasthenia in which the heart is especially affected, depending in part on inherited physical and psychical defects, and more immediately on infective toxæmia (as from enteric, malaria, trench fever, amoebic dysentery, tuberculosis, influenza), or on exposure to high temperatures, the cumulative strain of fatigue with insufficient food and sleep, or great nervous shock or stress, associated sometimes with endocrinic disturbance (thyroid or adrenal), the psychical factor becoming evidently more and more important as observations accumulate. Rest, though useful, indeed necessary, at first, has later been superseded, after a sufficient interval, by carefully graduated exercises, carried on amidst the curative

psychical atmosphere of a busy and successful treatment centre. For such "vagal" symptoms as fainting, with slow, feeble pulse, atropine has been used with advantage. But the disease remains exceedingly refractory. Many cases are still uncured, and many have only recovered after many months. The majority may, however, be perhaps regarded as recovered.

Speaking with much diffidence from a limited personal experience I cannot but think there are possibly several types still not disentangled. For I have seen cases which seemed obviously associated with hyperthyroidism, and others equally suggestive of toxæmia with no obvious endocrinic change—one such I afterwards heard was fatal from syncope.

For the rest, still uncured, we may well continue to hope; but Da Costa's experience that 28 out of 200 afterwards developed "cardiac hypertrophy," and the record of some writers on the Balkan war cases (quoted by Dr. Carey Coombs) that "premature arterio-sclerosis" (probably the same condition as Da Costa's) commonly occurred as a sequel, must be borne in mind. It will be important to determine, if we can, what particular causes have been connected with the cases in which such a sequel shows itself.

In conclusion, gentlemen, I hope that the shortcomings, which you cannot but find in this very condensed summary, will meet with the excuse that my material has been exceptionally difficult to deal with. If in anything I have seemed too frank, I hope I have at least not failed to be fair.

Memoranda:

MEDICAL, SURGICAL, OBSTETRICAL.

RADICAL CURE OF FEMORAL HERNIA BY THE INGUINAL ROUTE.

LIKE the majority of surgeons, I have for many years operated upon femoral hernia by the ordinary methods through the saphenous opening. Two or three years ago my attention was called to the method of operating by the inguinal route, and I have no hesitation in strongly recommending it. Mr. Percival Cole's description of the operation in the *BRITISH MEDICAL JOURNAL* of June 21st, 1919, is an excellent one and should be followed.

The advantages of this method are: (1) The greater likelihood of a permanent cure, for the ordinary operation, even in the hands of experts, is attended by frequent recurrence, and I have at present under my care a woman with a femoral hernia upon whom six unsuccessful operations have been performed by hospital surgeons. (2) A thorough examination of the gut can be carried out, and, if necessary, the gut can be resected. Quite recently I drew down and repaired the places which had been damaged in a tightly strangulated hernia. By the old method this could only have been done by weakening the ring, with the probability of a speedy return of the hernia. (3) Abnormal vessels are avoided. This may not be of much importance, but quite recently I tied the obturator as it curved round the neck of the sac.

There are also disadvantages. It is a rather more difficult operation than the ordinary one, and I have found the passage of the needle when suturing Cooper's ligament to the conjoined tendon troublesome, especially in stout patients. It is easier in females than in males, as in the latter the cord obstructs. In a recent textbook the operation is not, in my opinion, correctly described, for whereas the conjoined tendon should be sutured to the posterior border of the ring, the book in question describes the suture of the ring itself and does not mention the conjoined tendon.

Liverpool.

G. P. NEWBOLT, C.B.E., F.R.C.S. Eng.

ECTOPIA VESICÆ SUCCESSFULLY TREATED BY TRANSPLANTATION OF THE TRIGONE INTO THE SIGMOID.

MANY operations have been devised to remedy this distressing condition, but few have proved satisfactory. None of the many attempts to restore the bladder by plastic operations has answered the purpose; it is impossible to reconstruct the sphincter, and the operations have added

little, if anything, to the comfort of the patient. Attempts to transplant the ureters into the sigmoid or rectum have sometimes succeeded, but the great objection to all operations of this kind is the very serious risk of infection spreading along the ureter to the pelvis of the kidney.

It is essential that the valvular action of the ureteral orifices should be preserved, and this can apparently be secured by the operation described by Maydl in 1896, in which the trigone of the bladder is transplanted into the sigmoid flexure of the rectum. Such an operation was recently performed by myself, and the result up to the present time has been completely satisfactory.

A girl, aged 6, was admitted to the East Suffolk Hospital in May, 1920; the operation was performed on June 2nd. The upper three-quarters of the bladder was completely removed by a semicircular incision through the skin just outside the junction with the vesical mucous membrane, extending into the peritoneal cavity; the incision was carried across the base just above the trigone, and the abdominal cavity plugged with a gauze pad.

The base of the bladder, an elliptical area of $1\frac{1}{2}$ in. across by $\frac{3}{4}$ in. vertically, including the trigone and the ureteral orifices—situated $\frac{1}{2}$ in. from each end of the transverse diameter—was then raised by dissection, care being taken to avoid stripping the ureters and interfering in any way with their vascular and nervous supply. A loop of the sigmoid could easily be brought down to the level of the raised trigone. The loop being clamped, a longitudinal incision was made along it through the sero-muscular coat, and the posterior surface of the upper margin of the portion of bladder was sewn to the bowel about $\frac{1}{4}$ in. from this line by a continuous Lembert suture of fine silk. The bowel was then opened and the mucous membrane of the bladder and bowel were sewn together by a continuous catgut suture passing through the whole wall of each viscus, exactly as in the ordinary operation for gastro-jejunostomy. The silk suture was then continued for the remainder of the circumference through the sero-muscular coat of the bowel and muscular wall of the bladder, in the same way as the operation of gastro-jejunostomy is completed, so that the bladder wall formed part of the wall of the sigmoid, completely closing the gap. The bowel was replaced and the gap in the abdominal wall resulting from the removal of the bladder closed by silk-worm sutures. The patient made an excellent recovery; there was no shock and the convalescence was normal.

At the present time—more than five months after the operation—the patient is perfectly well and happy, with a soundly healed scar. The bowel has retained the urine without the slightest difficulty; there has been no leakage or incontinence. The urine is retained all night, from 9 p.m. to 7 a.m., and during the day is passed at intervals of four or five hours.

HERBERT H. BROWN, O.B.E., M.D., F.R.C.S.,

Ipswich.

Surgeon to the East Suffolk Hospital.

Reports of Societies.

"DOUBLE UTERUS."

At a meeting of the Edinburgh Obstetrical Society, held on December 8th, 1920, with Dr. WILLIAM FORDYCE, President, in the chair, Dr. D. ROBERTSON DOBIE read a paper on pregnancy and labour in a double uterus. He discussed the different ways in which this condition may impede labour, and described an illustrative case. On examination after the onset of labour the vagina was found to be blocked by what seemed a pedunculated mass. At a later examination only did the actual condition become clear. By this time the foetal head had come down, but it was held by a band, like a strong adhesion, crossing the vagina. This was the septum between the two cervixes, and had to be divided before delivery was possible. The extraction was then accomplished with forceps. After delivery the pedunculated mass that blocked the canal in the early stages was found to be the unimpregnated uterus, the cervix of which had been driven down to the vulvar outlet.

Dr. HAULTAIN referred to the great difficulty in diagnosis presented by these cases. He mentioned a case where the unimpregnated half of the uterus had been mistaken for a fibroid and had been removed. Dr. BALLANTYNE pointed out that the expression "double uterus" was a misnomer, as the condition was really one of two half uteri.

Dr. HAIG FERGUSON referred to a case in which the patient aborted from one half of the uterus at three months and six months later was delivered of a full-time child from the other half. Dr. LACKIE recorded a case where a thick band, similar to that in Dr. Dobie's case, blocked the

canal. In another case the patient menstruated from one side one month and from the other side the following month.

Dr. H. R. A. PHILP then gave a communication on obstetric practice amongst the Akikuyu tribe of Kenya Colony, British East Africa.

He described the ceremonies which are carried out at the initiation of the girls into the tribal life. The most barbarous of these consists in the removal of the external genital organs. The girls are lined up in a sitting posture with the legs separated, whilst an old woman passes from one to the other and, regardless of their cries, removes the labia with a sweep of her knife. This is an invariable practice in the tribe, although the missionaries are making every effort to stamp it out. Another barbarous custom is the sending of difficult labour cases into the bush to die.

Reviews.

ORTHOPAEDIC AND REPARATIVE SURGERY.

MORE than fifty surgeons have combined to make public the fruits of their experience of modern orthopaedic and conservative surgery in the two volumes of *Chirurgie Réparatrice et Orthopédique*,¹ published under the direction of Messrs. JEANBRAU, NOVÉ-JOSSERAND, OMBREDANNE, and DESFOSSES, so that this work may be almost considered as a system of reparative surgery. The preface, in which it is truly said that the advance in the treatment of injuries, which took place during the war, must be maintained for the benefit of the injured in peace time, is for the rest a paean of triumph of French surgery; for it all advances made during the war are claimed; no credit, so far as we can find, is given to allied or enemy surgery. But this is a harmless exhibition of national vanity which may be pardoned in the circumstances and which does not seriously detract from the value of the book as a guide to treatment, seeing that the various authors, while sufficiently patriotic, do not hesitate to quote the names of alien surgeons.

It is difficult within the scope of a review to criticize a work of this magnitude adequately, but an attempt to indicate its merits is possible. It deals with the treatment of wounds and injuries of every description in war and peace, in an introduction and sixteen chapters. In addition, it contains an article of 47 pages by Professor Jeanbrau on French war pensions, and the text of the law of March 31st, 1919, on this subject is printed as an appendix. A bill has been introduced in the Senate to extend the provisions of this law to the civil population and to provide the necessary special clinics.

In the introduction Dr. Lemaitre discusses the general principles of the modern treatment of wounds, laying more stress upon the removal of injured tissue and even on excision than on irrigation methods, such as that of Carrel, in the treatment of infected wounds. Professor Patel deals with the operative and orthopaedic treatment of war fractures and the application of these methods to civil practice. In this connexion it is as well to note that in France "orthopaedic" is used as contrasted with "operative" to denote treatment by the use of instruments alone, a sense which is happily obsolete in this country and in America.

Dr. Ledoux-Lebard defines the general principles of the radiological localization of foreign bodies and the proceedings necessary for their extraction. The chapters by Professor Ombredanne on the late removal of projectiles, and particularly those chapters concerned with plastic surgery, on which he is an acknowledged authority, are very valuable. The several chapters on orthopaedic and prosthetic apparatus are welcome, for these are subjects not adequately dealt with in surgical works in the English language. In these chapters Dueroquet, Calvé, A. Trèves, Nové-Josserand, Hendrix, and others describe not only suitable apparatus, but the principles upon which they should be constructed.

Dr. Roux-Berger contributes an interesting and lucid article on the sequelae of wounds of the chest and their treatment by the methods which constitute one of the

¹ *Chirurgie Réparatrice et Orthopédique*. Publiée sous la direction de MM. E. Jeanbrau, P. Nové-Josserand, L. Ombredanne, et P. Desfosses, Secrétaires de la rédaction. Paris: Masson et Cie. 1920. 2 vols. (Roy. 8vo. pp. 671; 518 figures, 7 plates. 80 francs net.)

striking advances made by surgery during the war. The boldness of conception and skill in execution of this branch of surgery is well brought out by the descriptions and excellent illustrations in this chapter. Sicard and Froelich write on the post-traumatic sequelae of injuries of the spine and of the contents of the spinal canal, and the latter has some useful pages on the so-called spontaneous lesions of the vertebral column which should be distinguished from the results of traumatism.

The abdomen, which offers so wide a field for surgery in primary lesions, does not bulk largely in reparative surgery. Ventral hernia and artificial anus and their cure, and urethral fistula are the only subjects in this chapter, and the last seems to be hardly correctly described as an abdominal lesion.

Osteo-articular lesions necessarily occupy much space. The treatment of ankylosis, of malunion of fractures, of pseudarthrosis in all its forms and of flail joints receive full notice from a number of authors.

Professor Lambret's article on cinematization of amputation stumps is short, but to the point, and we agree with his conclusions. The suggestions of Vanghetti have been put in practice for at least five years, but we are not yet in a position to estimate their practical value. This, as Professor Lambret says, is largely due to the want of satisfactory prostheses for these cases. The technique of the operations for the provision of plastic motors has been worked out and may be considered established: it is comparatively easy thus to procure adequate and resistant sources of power, but until satisfactory prostheses are available we are compelled to suspend judgement on this subject.

The production of this work, with its wealth of excellent illustrations, redounds to the credit of the publishers and editors who have been so enterprising as to undertake it and carry it through to so satisfactory a result. We have only one complaint to make, and when we call attention to the fact that an alphabetical index is lacking, we do so in the hope that this serious defect will be remedied in the next edition.

ENLARGEMENT OF THE PROSTATE.

To grow old gracefully is the hope of most men, but to grow old healthfully is the expectation of few. It is a source of immense satisfaction that surgery can do so much to make the old age of many men happy. When one reads in the new edition of FREYER'S *Clinical Lectures on Enlargement of the Prostate*² the grateful letters and comments of many of the patients to whom prostatectomy has given a new lease of life one feels that much good, after all, is being done, and the unpalatable memories of failures are forgotten. The operation of suprapubic prostatectomy associated with Sir Peter Freyer's name may now be regarded as standardized, to use a commercialism. Certainly in this country no other operation has anything like the same vogue, and the only comments in the past few years have been in the direction of prevention of such complications as haemorrhage and post-operative obstruction, and the advisability of doing a two-stage operation. There is no need to call attention to particular points in these lectures. Suffice it to say that they are written in racy, vigorous style, the details of cases cited are invariably interesting, and the work is founded on 1,600 cases carefully noted and honestly followed out to their conclusion. The book is one which certainly every surgeon ought to know and one which every general practitioner will find helpful.

This edition contains a new chapter on cancer of the prostate, a condition which is apparently more common than was formerly supposed. In Freyer's experience 13.8 per cent. of all his cases were clinically malignant, all but two cancer. He acknowledges that microscopic examination was not made in every case operated on, so that possibly the percentage is higher; indeed, it is so suggested by Albarran and Hallé, who argue that "adenomatous transformation of the prostate in advanced age is in a number of instances the primary stage of a malignant degeneration." We have known of other surgeons who have been surprised to find that a small tough prostate

difficult to remove, but regarded as simple pathologically, proved on examination to be cancerous. It would be well worth while submitting every prostate removed by operation to microscopic examination. The diagnosis of cancer of the prostate is by no means certain. If in a patient presenting the usual symptoms of prostatic enlargement one learns that "the symptoms have run their course rapidly in a few months only instead of as many years"; if the rectal examination discovers the prostate to be hard, irregular, immobile, tender to touch; and if catheterization is painful and the instrument meets with sudden resistance in the prostatic urethra, then the conclusion that the prostate is cancerous may safely be drawn. As to operability, experience shows that in some few cases enucleation is practicable and apparently curative, but the surgeon will require to determine the matter for himself with one finger in the rectum and the other in the bladder through the suprapubic wound.

The chapter is a welcome addition to the book, though, being cast in the form of a clinical lecture, admittedly it touches not much more than the fringe of the subject. It is not unreasonable to hope that doctors will make rectal examinations more frequently, and so capture these early cancerous prostates and give both patient and surgeon a chance.

ANATOMY AND MUSCULAR EXERCISES.

THAT a second edition of *Applied Anatomy and Kinesiology*³ should have been called for within two years of the appearance of the first is evidence of a demand for anatomical knowledge on the part of those who teach the various systems of physical exercises now practised, and also on the part of their pupils. We agree that our knowledge of muscles, particularly of their combination to produce familiar actions, is not well set out in our standard textbooks of anatomy, and that there is great need for a book such as this in which movements of the living body form the theme and the dissected body the dissection.

In spite of very excellent illustrations and clearly worded explanations, Professor Bowen's second edition suffers from the defects of the first: it is based on a superficial knowledge of the physiology of the human body, which, in our opinion, is even more important to an instructor in gymnastics or graduated exercises than a complete mastery of the anatomical details relating to muscles, bones, and joints. To exemplify the reason for making this criticism the reader may be referred to the chapter devoted to the upright posture. There the student is taught that in some respects the human body is not adapted for the upright posture—as shown by the lack of valves in the inferior vena cava and the presence of valves in intercostal veins where they are regarded as unnecessary. The inferior vena cava is part of the great venous cistern from which the heart is filled; even moderate exercise leads to the distension of this cistern; violent and prolonged exercise has been known to cause it to rupture. If valves were provided they would be not only useless, but injurious. The valves in the intercostal veins, as in veins arising in and passing among muscles have nothing to do with the upright or horizontal posture, but are provided to secure the passage of blood towards the heart during intermittent and alternating action of the adjacent muscles. No one can teach or practise exercises intelligently unless the significance of venous valves has first been grasped.

The "location of the vermiform appendix" is also cited as another instance of imperfect adaptation to upright posture in man. "The upright position shifts this structure from the highest level of the digestive tract in the quadruped to the lowest in man, where it is subject to much greater pressure and liable to irritation by fragments of food forced into it by changes in pressure." Such a statement will find no support from what is known of the comparative anatomy or of the physiology of the intestinal tract.

We might have cited statements equally ill founded from the chapters devoted to the spinal musculature, to the action of the muscles of the leg and foot in maintaining the weight of the body in standing and in walking, or in

²*Clinical Lectures on Enlargement of the Prostate.* With a description of the author's operation of total enucleation of the organ. By Sir Peter J. Freyer, K.C.B., M.D., M.Ch., LL.D. London: Baillière, Tindall, and Cox. 1920. (Demy 8vo, pp. viii + 174; 56 plates. 10s. 6d. net.)

³*Applied Anatomy and Kinesiology: The Mechanism of Muscular Movement.* By Wilbur Pardon Bowen, M.S., Professor of Physical Education, Michigan State Normal College. Second edition. Philadelphia and New York: Lea and Febiger. 1919. (Med. 8vo, pp. 334; 197 figures.)

the chapter devoted to breathing and breathing exercises. The book in many respects is so good that we hope in a future edition the principles of physiology which underlie the practice of "kinesiology" may receive a rendering more in keeping with modern knowledge.

DISEASES OF AVIATORS.

AVIATION demands a high degree of physical fitness and mental balance from those devoting themselves to it, whether in war or peace. Drs. MAUBLANC and RATIÉ, with several years of experience behind them, have written a short and lucid account⁴ of the methods they employ in the medical examination of aviators and candidates wishing to take up aviation; they lay stress on the importance of the following points in any such examination. Candidates should be rejected if their past history gives evidence of major or minor epilepsy, tuberculosis, recent malarial infection, or war wounds leaving behind them definite evidences of injuries to nerves, joints, the central nervous system, or the lungs. Similarly, valvular disease of the heart, high arterial blood pressure, or marked functional cardiac disturbances, emphysema, or tuberculosis of the lungs, the presence of extensive pleural adhesions, definite diseases of the abdominal viscera generally, diminution of the visual fields or marked ametropia, deafness, liability to attacks of vertigo, and inadequate response to tests of sensorial acuity or variations of equilibrium, are all adequate causes for the rejection of any candidate. The authors devote forty pages to the description of their various methods of testing the reactivity to sensory impressions (visual, auditory, tactile) and to changes of equilibrium; these methods are applied to candidates who have passed the more medical examination indicated above. The book is clearly written, and should be in the hands of all medical men who have to do with aviators or the selection of candidates for aviation.

The book, *Aviation Disease, its Cause and Remedies*,⁵ by Professor CRUCHET and Dr. MOULINIER, deals with a subject studied by these authors since the year 1910. The symptoms of the disease come on chiefly at the higher altitudes of flight and in the course of long flights; they are aggravated by unduly rapid descents. They consist of such things as dyspnoea, palpitations, nausea, deafness, psychical defects of vision, loss of the sense of orientation, headache, lumbago, and increasing slowness of ideation, or somnolence. Naturally, the clinical picture varies in different instances. Discussing the causes of aviation disease, the authors lay great stress on the rise of minimum arterial blood pressure that always is observed in it, but is not observed in the well-trained and fit aviator; other factors, such as fatigue, exposure to cold, intellectual and emotional exhaustion, temporary or permanent disorders of the auditory apparatus, and undue rapidity in descending to earth, are contributory but less important in the development of the disease. In effect, the whole syndrome is brought about by unduly rapid rising to high altitudes, as in mountain sickness, or unduly rapid descent. Discussing the training of aviators with a view to rendering them less liable to the physical and cardiac fatigue that lead to the development of the symptoms described above, the authors emphasize the importance of giving rest to aviators as soon as they develop evidences of such fatigue, whether mental or bodily; it may be added that a good picture of the mental exhaustion typically demanding a change of occupation in an aviator is furnished in some chapters of Mr. J. E. GURDON'S *Over and Above*,⁶ a book describing the experiences of an aviator flying in France during the recent war. Professor Cruchet and Dr. Moulinier produce a considerable amount of evidence in favour of the views they advance, and their little book will be read with interest by aviators and the medical men who have charge of them.

⁴ *Guide pratique pour l'Examen Médical des Aviateurs des Candidats à l'Aviation et de Pilotes.* Par Drs. Maublanc et Ratié, Médecins du Centre d'Aviation de Chartres. Paris: J. B. Baillière et Fils. 1920. (Imp. 16mo, pp. 109; 25 figures. Fr. 3.)

⁵ *Le Mal des Aviateurs: Ses Causes et ses Remèdes.* Par Dr. René Cruchet, Professeur agrégé à la Faculté de Médecine, et Dr. René Moulinier, Médecin de la Marine. Paris: J. B. Baillière et Fils. 1920. (Post 8vo, pp. 94; 12 figures. Fr. 3.)

⁶ *Over and Above.* By John E. Gurdon. London: W. Collins, Sons and Co., Ltd. 1919. (Cr 8vo, pp. v + 250. 7s. 6d. net.)

MIDWIFERY.

DR. JELLETT'S *Short Practice of Midwifery*⁷ is so well known that the appearance of an eighth edition calls for little more than mention. The text has been thoroughly revised and, where necessary, brought into line with the practice taught and carried out at the Rotunda Hospital, Dublin, during the author's term as Master. Many of the illustrations have been redrawn and improved, and Dr. English has added a most interesting statistical table in the form of an appendix, which shows the nature and proportion of all the cases treated in the Rotunda during the masterships of Sir W. J. Smyly, Dr. R. D. Purefoy, Dr. E. H. Tweedy, and Dr. Jellett. As the grand total of cases so reviewed is over fifty-one thousand, it will be realized that few similar tables are available from which more reliable data can be drawn. To teachers this appendix will prove of the greatest value and interest. From every point of view this remains one of the best of the smaller textbooks of midwifery in the language.

An equally well known book in its sphere is Professor JARDINE'S *Practical Textbook of Midwifery for Nurses*,⁸ which now makes its appearance in a seventh edition. In substance it remains much as it was in the last edition, and the teaching contained in it has proved so suitable to the needs of so many nurses that not much change could be either expected or desired. The new edition will continue to be the *vade mecum* of many maternity nurses, and they will find in its pages practically all that they require to know either for the practice of their profession or for the examinations of the Central Midwives Boards.

A SYNOPSIS OF MEDICINE.

Books which attempt to condense into a short "compendium" the whole survey of medicine turn out, as a rule, to be cram books for the student, and more often than not, bad cram books. Dr. TIDY, in his *Synopsis of Medicine*,⁹ has succeeded in compiling a better compendium than seemed possible to expect. In compact form this volume furnishes an admirable *index medicus*. The author, in his preface, expresses very modest hopes that his book may sometimes prove useful "to those who have to revise rapidly their knowledge of medicine in general or of some disease in particular." Its usefulness will not be so limited. The scope of the work is far wider than in the majority of similar books. To take a single example: "Tuberculosis" is discussed more fully and a good deal more intelligibly than in the average textbook. Modern experiments and modern theories are adequately presented. Or again, in the section on diseases of the nervous system, the anatomy and physiology of the nervous system will be found clearly described and ably linked up with the clinical manifestations of pathological changes. The discussion of carbohydrate metabolism in reference to diabetes is wonderfully clear and comprehensive. Throughout the book "treatment" meets with ample consideration, and this fact alone will enhance its value enormously for the busy practitioner. Dr. Tidy is to be congratulated on having written a good book and given it a good index. The publishers have so contrived, without sacrificing the quality of either the paper or the type, that it will slip into a fair-sized overcoat pocket.

NOTES ON BOOKS.

DR. GABRIEL BIDOU is known as the author of a monograph on instrumental orthopaedics, which was reviewed by us in our issue of August 2nd, 1919, p. 138. In the pamphlet he has recently issued on the action of artificial muscles¹⁰ the same subject is dealt with, and a walking instrument for a case of paralysis of the lower limb is

⁷ *A Short Practice of Midwifery.* By Henry Jellett, M.D., F.R.C.P. Ire. Eighth edition, revised. London: J. and A. Churchill. 1921. (Demy 8vo, pp. 564; 235 figures. 18s. net.)

⁸ *A Practical Textbook of Midwifery for Nurses.* By Robert Jardine, M.D. Seventh edition, revised and enlarged. London: Henry Kimpton. 1920. (Cr. 8vo, pp. 311; 69 figures. 7s. 6d. net.)

⁹ *A Synopsis of Medicine.* By Henry Letheby Tidy, M.A., M.D., B.Ch.Oxon., F.R.C.P.Lond. Bristol: J. Wright and Sons, Ltd. London: Simpkin, Marshall, Hamilton, Kent and Co. Toronto: Macmillan Co. of Canada, Ltd. 1920. (Cr. 8vo, pp. xv+952. 25s.; postage 1s.)

¹⁰ *Des actions musculaires artificielles.* Par Dr. G. Bidou. Paris: "La Vie Médicale." 1920. (Fcap. 8vo. 15 pp.; 4 figures + 2 plates.)

described and illustrated. Reproductions of cinematographic films of the patient walking with and without the appliance are appended, and are of some interest. Dr. Bidou employs spiral springs, generally in groups, as artificial muscles, so adjusted in strength and in leverage as to help or replace paralysed muscles. Another use to which he puts the springs is as antagonists: their action then is that of a spring buffer which comes into play at the end of the movement.

APPLIANCES AND PREPARATIONS.

Improvements for Use with Gas-Oxygen-Ether Outfit.

Mr. H. EDMUND G. BOYLE (London, W.) writes: The accompanying illustrations depict some improvements that have been made for use with my gas-oxygen-ether outfit. The first depicts an improved ether or mixture bottle; this comprises a three way valve, below which is a perforated cup that can be raised or lowered upon the inlet tube inside the bottle. The inlet tube is perforated in two places, the upper being inside the cup and the lower one below the cup. The open end of the tube makes a third aperture. A filling funnel is placed behind the valve. The advantages of this bottle are that the anaesthetist can graduate the amount of ether or mixture better than was possible with the older pattern, for with this bottle the gases can pass in three ways: (1) To the patient direct and without any ether; (2) over

the surface of the ether or mixture, thus giving quite a small amount; (3) through the ether or mixture when the anaesthesia has to be deepened. The second illustration depicts a nasal attachment; this comprises a metal stirrup to which are attached a couple of short soft rubber tubes. I have found this very useful for endobuccal and endopharyngeal anaesthesia, and especially for such cases as diathermy of the tongue or palate, or for oesophagostomy and bronchostomy. It is also very useful for some operations upon glands in the neck, enabling the anaesthetist to keep well out of the way of the surgeon. The rubber tubes should be about four inches long.

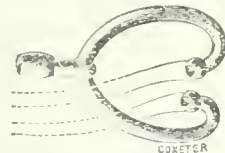

College and Queen Square Hospitals he had a very large consulting practice.

No record of Sir Victor Horsley's life-work, however brief, would be complete without mention of his unselfish enthusiasm for the social betterment of his fellows. Over and above his great achievements in science and in surgery he will ever be remembered for his devotion to the causes of temperance, the enfranchisement and equal treatment of women, the education and welfare of children, and the removal of the abuses inherent in the slums of our great cities.

Vehemence in pursuit of his political ideals sometimes gave offence, but this can be forgiven and forgotten, and there remains only the memory of a unique character, whose brilliance shed its lustre on his profession and his life-work.

It is suggested that the most appropriate trustees would be the Senate of the University of London, and that if a Lectureship should be finally decided upon, the subject should be left widely open so as to secure the services of men distinguished in some department of public life who might consider it an honour to be the "Victor Horsley Lecturer" for the year.

General Committee. Sir Charles Ballance, K.C.M.G., (Chairman); Right Hon. Christopher Addison, M.P., Right Hon. Sir T. Clifford Allbutt, K.C.B., F.R.S., Ronald Armour, C.M.G., Dr. T. Ridley Bailey, Sir Hamilton Ballance, K.B.E., C.B., Sir Thos. Barlow, Bt., K.C.V.O., Dr. J. O. Wakelin Barratt, Lady Barrett, C.B.E., Sir H. J. Beevor, Bt., Sir John Land-Sutton, Dr. G. F. Blacker, C.B.E., Dr. R. A. Bolam, O.B.E. (Chairman of Council, British Medical Association), C. J. Bond, C.M.G., Sir Anthony Bowly, K.C.B., K.C.M.G., K.C.V.O., Sir J. Rose Bradford, K.C.M.G., C.B., C.B.E., F.R.S., S. H. Burton, F.R.C.S., Dr. L. Farquhar Buzzard, Sir W. Watson Cheyne, Bt., K.C.M.G., C.B., F.R.S., M.P., Dr. R. H. Clarke, Dr. Alfred Cox, O.B.E., Professor Crile (Cleveland), Dr. Douglas, Mrs. Fawcett, Sir David Ferrier, F.R.S., Right Hon. Lord Edmund Fitzmaurice, Right Hon. T. R. Fens, Dr. C. E. S. Flemming, Dr. A. Fulton, Dr. T. W. H. Garstang (Chairman Representative Meeting, British Medical Association), Dr. E. W. Goodall, O.B.E., Sir Rickman J. Godlee, Bt., K.C.V.O., N. Bishop Harman, Right Rev. Bishop J. E. Hine, Dr. Gordon Holmes, C.M.G., C.B.E., H. Huxley, Dr. James Inghy James, Raymond Johnson, O.B.E., Right Hon. Leif Jones, Dr. Joyce, Professor Arthur Keith, F.R.S., Dr. Lawrence, Sir John Macalister, Dr. A. Salisbury MacNalty, Sir George H. Mackens, G.C.M.G., C.B., Dr. J. A. Macdonald, Lieut.-Colonel R. McCarrison, Dr. Ewen J. Maclean, Colonel C. W. Mansell Moulin, C.B.E., Dr. Sidney Martin, F.R.S., Dr. Otto May, Colonel Sir A. W. Mayo-Robson, K.B.E., C.B., C.V.O., Professor Rutherford Morison, Sir Bkeley Moynihan, K.C.M.G., C.B., Dr. George R. Murray, Dr. J. J. Muskens (Amsterdam), Sir George Newman, K.C.B., Stephen Paget, J. Turner Rae, N.T.L., Lady Rhonda, Dr. J. S. Risien Russell, Lieut.-Colonel Sir Leonard Rogers, C.I.E., I.M.S., F.R.S., Sir Humphry D. Rolleston, K.C.B., Percy Rose, Sir Michael E. Sadler, C.B., K.C.S.I., Percy Sargent, C.M.G., D.S.O., Dr. Mary D. Seabrook, C.B.E., Sir E. Sharpey Schafer, F.R.S., Sir Felix Semon, K.C.V.O., Dr. Lauriston Shaw, Dr. R. Townley Singer, Professor C. S. Sherrington, F.R.S., W. G. Spencer, O.B.E., Dr. Squire Spidege, Professor E. H. Starling, F.R.S., Dr. Mary Sturge, Dr. May Thorne, O.B.E., W. Trotter, F.R.T., Jenner Verrall, Dr. S. Russell Wells (Vice-Chancellor University of London), Dr. W. Camac Wilkinson, Dr. W. H. Willcox, C.B., C.M.G., Dr. Dawson Williams, C.B.E., J. Smith Whitaker, Sir J. Sims Woodhead, K.B.E.

* Members of Executive Committee.

Honorary Treasurers. Sir Frederick Mott, K.B.E., F.R.S., 25, Nottingham Place, W.1; Dr. H. H. Tooth, C.B., C.M.G., 34, Harley Street, W.1.

Honorary Secretaries. Sir W. Arbuthnot Lane, Bt., 21, Cavendish Square, W.1; Edward J. Donaville, O.B.E., Symondsbury, Bridport.

Subscriptions may be paid to one of the above-named officers or to "the Victor Horsley Memorial account" at the London County, Westminster and Parr's Bank, Hanover Square Branch, London, W.1.

FIRST LIST OF SUBSCRIPTIONS.

- £10 10s.—Sir Frederick Mott, K.B.E., and Lady Mott, Dr. Camac Wilkinson, Sir George Newman, K.C.B., Dr. J. O. Wakelin Barratt, Dr. and Mrs. George Murray.
- £10.—Right Hon. Lord Edmund Fitzmaurice, Sir Felix Semon, K.C.V.O., Dr. Mary Sturge, Dr. Slinger, C. J. Bond, C.M.G., Dr. Farquhar Buzzard, Right Hon. Leif Jones, Percy Sargent, C.M.G., D.S.O.
- £5 5s.—Sir W. Arbuthnot Lane, Bt., Sir J. Sims Woodhead, K.B.E., N. Bishop Harman, Dr. H. H. Tooth, C.B., C.M.G., Dr. Otto May, Dr. G. Salisbury MacNalty, Dr. Ewen J. Maclean, Edward J. Donaville, O.B.E., S. H. Burton, J. Smith Whitaker, Sir John Land-Sutton, Dr. G. F. Blacker, C.B.E., Lieut.-Colonel R. McCarrison, Mr. McCarrison, H. Huxley, Raymond Johnson, O.B.E., Dr. Gordon Holmes, C.M.G., C.B.E., Sir Hamilton Ballance, K.B.E., C.B., Dr. W. H. Willcox, C.B., C.M.G., Society of Members of the Royal College of Surgeons, Professor E. H. Starling, F.R.S.
- £5.—Right Hon. Sir T. Clifford Allbutt, K.C.B., Sir Charles Ballance, K.C.M.G., Dr. A. Fulton, Sir J. Rose Bradford, K.C.M.G., C.B., C.B.E., Rt. Hon. T. R. Fens, Dr. Frank Hinds, W. G. Spencer, F.R.C.S.
- £1 5s.—Mr. and Mrs. Stephen Paget, Sir Rickman J. Godlee, Bt., K.C.V.O.
- £2 2s.—Dr. R. A. Bolam, O.B.E., Dr. T. Ridley Bailey, Sir T. Jenner Verrall, LL.D., Dr. Dawson Williams, Dr. R. H. Clarke, Dr. Percy Rose, Dr. Steen, Dr. Lauriston Shaw, Dr. E. W. Goodall, O.B.E., Dr. Alfred Cox, O.B.E., Dr. Ridden, Lady Barrett, C.B.E., Sir A. W. Mayo-Robson, K.B.E., C.B., C.V.O., Sir Leonard Rogers, C.I.E., M.D., Sir Hugh Beevor, Bt., M.D.
- £1 2s.—Dr. C. E. S. Flemming, Dr. Garstang, Dr. Hawthorne, Sir Charles Harrison, Dr. O'Sullivan, Dr. Henry Sturge, Colonel Mansell Moutho, C.B.E., Professor Rutherford Morison, Dr. Eleanor Lowry, Dr. Russell Wells, Anonymous
- £1.—Miss Powning, Dr. Henry Bird, Dr. J. J. Muskens.

MEMORIAL TO SIR VICTOR HORSLEY.

A GENERAL COMMITTEE, formed some time ago to take steps to promote a memorial to the late Sir Victor Horsley, has issued the following circular letter:

It has been decided, at a meeting of friends and former colleagues of the late Colonel Sir Victor Horsley, to take steps to commemorate his services to science and the Empire by the foundation of a lectureship or scholarship bearing his name.

The tragic circumstances of his untimely death while on service in Mesopotamia are still fresh in remembrance, and though the absence of so many medical men on war service prevented an earlier movement, we are satisfied that it is not too late for the recognition in a permanent form of Sir Victor's life and work.

He was one of the most noteworthy students of University College Hospital, a very distinguished medallist and graduate of the University of London, and a leader and first Chairman of the Representative Meeting of the British Medical Association. He was a Fellow of the Royal Society and a pioneer in the research work connected with the surgery of the brain and nervous system and the causation of myxoedema; and as secretary of the Commission appointed to inquire into the value of Pasteur's method of treating rabies, his investigations at the Brown Institute were of the utmost value as proving the possibility of stamping out rabies in Great Britain.

Many students have cause to be grateful to him for his painstaking teaching and help in their work; and in addition to his appointments as surgeon to University

REFORM IN MEDICAL EDUCATION.

[FROM A CORRESPONDENT.]

I.

For some time past, but especially during the last three years, the General Medical Council has been dealing with matters of the utmost importance in respect of the whole subject of medical education, and the trend of opinion shown in the reports presented to the Council and in the discussions on them, indicates the probability, indeed almost the certainty, of a very thorough revision in the teaching of medicine at the medical schools throughout the country. It is to be noted, however, that the relation of the Council to the universities and colleges is not such as to give it direct control over the curriculum. The licensing bodies have practical autonomy, so that the Council can only make recommendations which may or may not be adopted, the ultimate power of the Council being limited to advising the Privy Council to refuse registration of the licences or degrees granted by any body whose standards had become so unsatisfactory as to demand such drastic action. The Privy Council has never so refused. The Council itself, however, is mainly composed of representatives of the licensing bodies, and consequently its recommendations are likely to be in accord with the general opinions of the schools.

Though the JOURNAL has regularly published reports of the doings of the Council at its half-yearly sessions, it is proposed now, notwithstanding that it involves some degree of repetition of what has already appeared in the columns of the SUPPLEMENT, to review and summarize the proceedings for several years past with respect to the subject of reform in the existing scheme of medical education. The published minutes, reports, and discussions of the Council and its Education Committee are the sources of information.

THE TEACHING OF PREVENTIVE MEDICINE.

It will be convenient to deal first with preventive medicine; at the Council's May session of 1918 a motion was adopted:

"That it be remitted to the Education Committee (1) to report to the November session of the Council as to whether the Council should take any action towards promoting or systematizing the teaching of preventive medicine in the medical schools and in clinical hospitals throughout the country; and (2) to make such inquiry as the Committee may find necessary to enable it to report."

Before the end of the year the Committee, to which two *ad hoc* members had been added, issued to the medical schools a circular letter containing a series of queries regarding the teaching of preventive medicine. In submitting the queries it was explained that they were not intended to refer to the existing teaching of sanitary science for qualifications in medicine or for degrees or diplomas in public health. "What the Council has in view," it was said, "is rather the teaching of the schools and the clinical hospitals regarding the maintenance of health from birth onwards, the effect of conditions, including occupations, which are liable to cause illness, and the detection of the early evidence of disease in the individual, with a view to treatment of a preventive kind." The queries themselves give convenient exposition of what was in the mind of the Education Committee and the Council. Briefly, they refer to every subject of the curriculum, and they show the purpose of the Council to be that the prevention of disease, in addition to the cure of disease, should permeate the whole education of the student, from the preliminary sciences onwards to his entry into the profession of medicine. Of course, the ultimate object is that the education so acquired shall have its fruition in the preventive treatment of disease throughout the life of the medical practitioner.

At first sight, at least, it is not easy to perceive in what way preventive medicine can be taught in connexion with some of the subjects embraced in the curriculum, but the queries make clear what is in the mind of the Council, and some space must be devoted to noting the character of the questions propounded.

THE QUESTIONS.

Introductory Sciences.—Concerning physics, chemistry, and biology, it is asked whether these should include references to the later applications of these sciences to medicine; should the

teaching of any of them be continued at intervals through later stages of the curriculum, as, for example:

"Physics in direct relation to physical therapeutics, radiology, and electrical treatment?"

"Chemistry in relation to the normal changes of the body in health—that is, physiological or medical chemistry?"

"Zoology in relation to those conditions due to environment which affect the development of the normal organism, or in relation to the study of parasitology, with the view to eliminating sources of infection?"

Physiology.—As concerns physiology, the relation to health maintenance is obvious enough, and it is asked whether there should be fuller instruction in the physiology of normal human beings, and in the action of the organisms in normal human subjects—the exercise of normal functions as a condition of maintenance of health in respect of breathing, eating, drinking, exercise, rest, play, normal metabolism generally; also the physiology of normal childhood, adult life, and old age; the physiology and psychology of school life and the effects of over-pressure. In short, physiology constitutes, in old phraseology, the institutes of medicine.

Anatomy.—Here it is asked whether there should be fuller instruction in the conditions of growth and normal development in muscle, bone, nervous system, etc.; in the causes of imperfect development and physical degeneration; in anatomy in relation to orthopaedics, rickets, flat-foot; and to radiographic representation of structures, etc. It is further asked whether such teaching should be included in the regular courses or be given throughout the later years of the curriculum.

Psychology.—Another question, suggested by the war, is as to the far-reaching effects of intense emotion upon the functions of the sympathetic system and endocrine organs, and through them upon the working of every part of the body. Should medical students be taught psychology or the process of development of mental disturbance?

Pathology.—It is asked whether the teaching includes sufficient instruction in the early stages of the development of disease; whether etiology, as revealed in the history of individual cases, is sufficiently studied as a basis for the understanding of prevention; whether current teaching sufficiently brings out the distinction between stages of disease from which recovery can take place, and those which involve permanent changes and imperfect recovery or non-recovery.

Bacteriology.—It is asked whether the etiology of bacterial and other communicable diseases is sufficiently taught.

Materia Medica, Pharmacology, and Therapeutics.—Here it is asked whether current teaching deals sufficiently with therapeutics for the maintenance of health; whether it includes treatment by physical exercises and methods other than medicinal.

Clinical Courses.—In respect of this final and most important department of study it is asked whether it is desirable and practicable to include definite instruction in anatomy and physiology in their direct application to medicine as a basis for preventive measures; whether the teaching of clinical medicine extends beyond the immediate field of hospital treatment; whether instruction is sufficiently given in the preventive relationships of each several disease; in the means of preventing disease, individual and communal; in insidious disease, especially in the early stages; also as to attention to minor ailments; as to the significance of partial recovery in heart illness, kidneys, etc.; as to common septic infections; as to the relation of stunted growth and development to susceptibility to disease; as to diet in infancy, childhood and adult life; as to habits in regard to food and drink; as to the influence of occupation and exercise. In surgery similar questions are mentioned—the closer co-ordination of anatomy and physiology with surgery to provide a basis for knowledge of preventive measures; susceptibility to infection and the conditions which induce it; the prevention of septic infections; the care of patients after surgical treatment (rickets, surgical tuberculosis, etc.).

Special Subjects.—It is asked whether the courses include sufficient instruction in the preventive relationships of children's diseases, skin diseases, diseases of the eye, ear, nose, and throat, mental diseases, infectious fevers, venereal diseases, and tuberculosis.

Midwifery and Diseases of Infants and Young Children.—Here the questions are whether there is sufficient instruction in the prevention of disease in expectant mothers and in infants in connexion with child welfare schemes; in the maintenance of health during pregnancy; in the hygiene of infancy; the feeding of infants and young children; the effects of social conditions on infants' health in respect of milk supply, tuberculosis, rickets, diarrhoea, pneumonia, etc.; the sequelae of infectious diseases and the dangers of incomplete recovery.

Hospital Out-patient Departments.—Are these sufficiently adapted to and utilized for practical teaching of medical preventive care, and is full advantage taken of the material available for study of ailments at a stage before patients need to be sent to hospital or treated in bed at home?

Dentistry.—The Committee wish to know whether students receive sufficient instruction in the preventive relationships of dental disease and in the bearing of such disease on general health, and whether in the dental curriculum itself the preventive aspects of the subject are sufficiently enforced in relation to the causes of decay of the teeth.

In a concluding general note the Committee explain that they do not contemplate setting up new departments nor adding new

courses to the curriculum, but they wish to know whether the student gets practical insight into the existing voluntary and official methods of applying preventive measures, and whether he is taught how to avail himself of publicly provided services.

This statement of detail shows on what lines the Committee think that there could be inspiration of the whole course of medical study with the motive of maintenance of health as one of the primary objects in the work of the practitioner. It evidently desires that the student shall be so taught that throughout his professional life he shall constantly bear in mind the importance of his function as a practitioner of preventive medicine. No doubt the occasion of his coming into contact with his patients and so of obtaining opportunity for their treatment and instruction on preventive lines will at first be, in perhaps the majority of cases, the occurrence of some more or less trivial ailment, and it may be presumed that, in the opinion of the Committee, such opportunities should always be taken advantage of. In that connexion it is reasonable to think that the National Health Insurance scheme, whatever its merits or demerits, may tend to bring insured patients into earlier touch with their doctor than when every attendance meant a separate fee. But, in order to take full advantage of such opportunities, the medical practitioner must, in the first place, have been educated on preventive lines, and, in the second place, must have time to deal thoroughly even with apparently trifling cases and to continue his attendance so long as may be necessary for that purpose. Where illness incapacitates for work, he must, on the one hand, see that his patient does not develop into a valetudinarian by remaining too long on the pay list, and, on the other hand, he must advise his patient not to resume work prematurely and so run the risk of an early recurrence of his malady.

THE REPLIES FROM THE SCHOOLS.

The questionnaire was addressed to thirty-eight bodies, and thirty replies had been received up to May last. These are printed in full in the minutes of the Council, and form most suggestive and thought-provoking reading to all who have to do with medical education. Scores of interesting quotations could be made, but would occupy too much space. The Committee report that the replies "indicate by their general tenor that present day training does not concern itself sufficiently with the preparation of the student for the discharge of these important elements of the practitioner's duty."

The testimony of the schools varies very considerably as to the extent to which preventive medicine is taught throughout the curricula at the present time. No doubt the differences are partly due to differences in the teaching as between the medical centres, but probably also, apart from what is actually being taught, there is considerable variety of opinion as to what the standard should be.

One school declares that "at the present time students beginning clinical medicine have no adequate knowledge of the normal heart and breath sounds, the examination of gastric contents and faeces, or of the normal knee-jerks, fundus of the eye, making blood counts, etc." It is further stated that "the current teaching of pathology does not sufficiently bring out the distinction between stages of disease from which recovery can take place, and those which involve permanent changes and imperfect recovery or non-recovery." Concerning *materia medica*, pharmacology and therapeutics, it is declared that "the current teaching with regard to diet, exercise, ventilation, treatment by physical exercise, and methods other than medicinal, is far below what is desirable." In concluding its letter this school writes:

"General.—It is admitted that the student is not sufficiently taught how in his practice to avail himself, for the benefit of his patients, of publicly provided services. It is very desirable that the existing organization of medical teaching in the schools should enable the student to realize the meaning and importance of preventive care. By reorganization of the present arrangements, and by adaptations of the theoretical and practical treatment throughout the whole curriculum, the committee of this school is of opinion that students can, within the limits of the present curriculum, acquire the knowledge and experience desired."

These views, however, as to the degree of insufficiency of existing teaching of preventive medicine are not so strongly expressed by various other bodies. Generally, the position appears to be that a good deal of miscellaneous

teaching on preventive lines is already given throughout the curriculum, but the amount differs as between different schools and different subjects and different teachers. In several replies it is prophesied that the issue of the letter of inquiry will itself have a stimulating effect towards directing the teaching into the desired channel. It appears quite certain that this is a sound view. Whatever changes may be in store as regards the whole curriculum of medicine, and however long it may take to complete the revision of the curriculum, the full discussion of the place of preventive medicine in the tuition of the student and the replies prepared by the teaching bodies are bound to have a great influence on the outlook of the teachers in their respective subjects.

Among the more notable documents are those received from the Universities of Birmingham, Oxford, and Edinburgh, and from the Medical School of Guy's Hospital. The opinion of the Faculty of Medicine at Birmingham of the part played by drugs in the treatment of disease is thus expressed:

"The preventive treatment of disorders of metabolism remains a part of the course of lectures in therapeutics. The syllabus of the course of lectures in this subject includes mechano-therapeutics, as well as massage, and practical demonstrations are given as well as lectures on these subjects. In the course of pharmacology the attitude is taken that drugs are a special treatment of disease, and not for the maintenance of health, and that even in disease the proper treatment is often not by drugs, but by other means, such as diet, exercise, massage, electricity, properly regulated life, etc. It is pointed out that the great use of drugs is in emergencies, as some of them produce rapid effects and relieve pain with a rapidity which cannot be obtained by other means. It is insisted, however, that the use of drugs should be temporary, and only in exceptional instances should they be considered curative."

The University of Oxford points out that the clinical work of its students is done in the hospitals in London, and it therefore avoids comment on that section of the curriculum, but it discusses with much care the introductory science courses. The teachers of these sciences are usually not medical men, and, independently of that fact, it is not regarded as desirable to teach chemistry and physics merely for their subsequent application. Therefore the teaching of them to medical students is of the nature of a compromise. The teachers are informed by conference with the teachers of later subjects what particular kind of knowledge of chemistry and physics it is desirable that the students should possess as a basis for the study of their particular subjects. In zoology, however, special attention is paid to parasitology, and this is stated in the replies from many other schools. Concerning physiology, as pointed out in the report of the Education Committee, Oxford University has established, under the title of clinical physiology, a special course dealing with man in respect of the cerebrum, dietary, particular muscular acts, some features of the human life-cycle, etc. The course of clinical physiology at Oxford follows immediately after the general course of physiology.

Edinburgh University reports that in the clinical courses frequent opportunities occur for teaching the preventive aspects of medicine, and that these are utilized. The curriculum includes a course of dispensary practice, in which the student is taught the observation of cases from the beginning; minor ailments are studied, and disturbances due to occupation or imperfect diet or hygiene are interpreted. The dispensary teaching is regarded as forming an introduction to general practice, and the staff of teachers is composed largely of general practitioners. In the earlier subjects of the curriculum the University points out that several professorships and lectureships have been established with a close bearing on the matters dealt with in the questionnaire—chemistry in relation to medicine, including the teaching of physiological and pathological chemistry; invertebrate zoology; psychiatry; bacteriology; and lectureships on physical methods in the treatment of disease, and on applied anatomy. There is also a chair of tubercle.

The Medical School of Guy's Hospital makes a very full and thoughtful statement of its views. It holds that—

"An attempt should be made to direct the student's attention throughout his medical school course to the preventive aspect of medical practice. To this end it is suggested that useful work may be done in the preliminary, intermediate, and advanced periods of study. In the teaching of chemistry and physics stress could be laid on the relation of these sciences to the maintenance of a healthy environment, and in biology, upon

the influence of heredity upon good physique, and upon the hygienic effects of other living organisms upon man. It is not necessary that the teachers of these subjects should themselves be medical men, but as teachers in a medical school they should be encouraged to specialize in those branches of their sciences which have a bearing on personal hygiene and public health. There are obvious opportunities for teachers of anatomy and physiology to extend and accentuate those sections of their subjects which have a bearing on health and disease, and it might be possible to arrange special short courses of demonstrations by those junior teachers who are also working in the wards upon the anatomical and physiological relations of morbid conditions."

Concerning personal hygiene the school points out that:

"The main duty of a hospital is to afford medical attendance to persons who recognize that they are ill and apply for treatment of their ailments. Whatever changes may be made in the organization of the medical schools, regard must constantly be paid to the possibility of maintaining and increasing the capacity of the hospitals for carrying out their work." Yet—

"Inasmuch as many of the ailments for which treatment is sought are preventable, an opportunity is afforded, and is usually taken, to impress upon the individual patient the measures he might have personally taken to avoid his illness, and which, if he is ultimately cured or relieved, he should in the future take to prevent its recurrence or aggravation." And the school thinks that—

"It would no doubt increase the regularity with which this procedure is adopted and impress its importance both upon the patient and the students associated in his treatment if the custom of some physicians were more commonly used of handing to the patient, at the time of his discharge, printed instructions as to preventive measures applicable to his condition."

It further urges that:

"A great impetus would be given to preventive medicine of the personal hygiene type if in medical schools a special department for the medical inspection of apparently healthy persons were instituted. In such a department a member of the staff, assisted by senior assistants, would examine all applicants and inquire into their habits and environments, and give advice as to the measures to be taken to maintain a high or even higher standard of health. Such a department for children or adults would follow the line of infant welfare centres now established in connexion with some medical schools.

"The difficulty at the initiation of such a department would be to encourage attendance thereat. The introduction in the near future of the medical inspection of children attending continuation schools would perhaps afford an opportunity for an experiment to be made. The Board of Education might arrange that such medical schools as were willing to co-operate should be constituted as centres for the compulsory inspection of children attending their schools in the surrounding district. The young people who attended compulsorily under the scheme during school age should be encouraged to continue to do so voluntarily at the termination of their school period."

And it adds:

"If these and similar proposals are carried out it is believed that the attention of all those working in the school will gradually be drawn more and more to the importance of prevention, and that all teaching, both practical and theoretical, will be so permeated with the idea of prevention that practitioners trained under these conditions will be little likely to lose sight of its importance, whatever may be their lines of practice after qualification."

The above are only examples of the valuable material contained in the replies from the schools, but they serve to indicate the interest that is taken in the whole subject. As already stated, they seem to leave no doubt that preventive medicine will now occupy a larger place in the mind both of the teacher and of the student than ever it has done before throughout the whole of the medical curriculum.

(To be continued.)

THE scheme for the extension of the Royal Free Hospital is making satisfactory progress. The staff of the London School of Medicine for Women have generously increased their donation to the appeal fund for the extension of the hospital and medical school from £500 to £1,000. The extension of the hospital is to provide beds for that class of workers who live in small flats or lodgings, and are unable to afford the high fees necessarily charged by good nursing homes, but can afford the cost of their maintenance whilst sick (£4 per week). A few beds are now available for men and women at this charge, and twenty-five more beds will be ready early in the New Year. More beds for men, women and children will be provided as soon as funds permit. Donations and subscriptions should be sent to Sir Francis Leyland Barratt, Bt., honorary treasurer, Royal Free Hospital, Gray's Inn Road, W.C.1.

MOTOR NOTES FOR MEDICAL MEN.

BY H. MASSAC BUIST.

DOCTORS AND TO-DAY'S NEW MOTORING LAWS.

So far as they relate to the taxation of motor vehicles the provisions of the Finance Act, 1920, come into force on New Year's Day, as do the provisions of the Road Bill which hurriedly passed the House of Commons and the House of Lords in December. These new conditions, which entirely recast the method by which revenue is levied from the motoring movement, the schemes governing licences, the exhibition of identification marks on vehicles, and so forth, concern medical men in various ways. These may be summarized by a reminder as to the obligations to which the members of the profession owning motor vehicles are liable.

Henceforth medical men are not concerned with rebates on petrol duty, because the tax on motor fuels of all sorts ceases. As far as privately owned passenger vehicles are concerned—and this is the category under which the machines of medical men come—the increased scale of taxation levied by way of licence for the use of such vehicles is the substitute for the fuel scheme. Some doctors own motor bicycles, others three-wheelers, some cycle cars, and some motor cars proper.

Broadly, motor bicycles and three-wheelers not exceeding certain weight limits are taxed by weight—a different scheme from that governing motor cars. But the initial method of procedure is the same in all cases. Hitherto, by the law that lapsed on the last day of December, 1920, it has been possible for a medical practitioner resident in Yorkshire to register a car in London and to buy his annual licence to use it at a post-office in Cornwall, it being necessary merely to take out locally a driving licence at the cost of 5s. a year. The new scheme of taxation does not concern itself with drivers' licences, which have still to be taken out locally. But from New Year's Day onwards the registration and the licensing authorities are centred in the same places. Owners are compelled to register their vehicles either in the districts wherein they reside or where they have most occasion to use their vehicles. Further, the yearly licence for the use of the vehicle has to be taken out locally, just as the driver's licence has always had to be taken out.

THE SCALE OF CHARGES.

Any private vehicle not exceeding 6 h.p., or which is propelled electrically, involves the payment by the owner of an annual licence fee of £6. For any privately owned motor vehicle exceeding 6 h.p. £1 will be payable for each unit, or portion of a unit, of horse-power according to Treasury rating. That is to say, the ownership and use of a 15.9 h.p. Treasury rating car involves the payment of an annual tax of £16, and so on. Many doctors, however, are still so fortunate as to have in use old cars which are serving them well. Some of these, of course, are constructed on engine principles which are rather hard hit by the adoption of Treasury rating in that the bore measurement is relatively large in comparison with the piston travel. Many such, however, will find a certain measure of relief in the section which reads:

"If any person proves to the satisfaction of the authority charged with levying the duty that he has paid in respect of any vehicle the duty chargeable under this paragraph (Section 6 of the 2nd Schedule of the Finance Act), and that the engine of the vehicle was constructed before the 1st of January, 1913, he shall be entitled to the repayment of 25 per cent. of the duty paid."

This, being interpreted, means that the owner of an old vehicle has a certain measure of relief on the assumption that it will not be giving him as satisfactory service to-day as when he purchased it. Inasmuch as the tendency in the last seven years has been to increase the piston travel in relation to the bore measurement, the continued ownership and use of these older-style vehicles is not penalized, for 25 per cent. rebate is really a fair allowance.

NATURE OF LICENCES.

The Ministry of Transport has lately issued an official memorandum setting out the course to be adopted by car owners before New Year's Day. For the purposes of reminder, and for the sake of clearness, however, it will

be well to recapitulate the main heads of this memorandum as it concerns the medical man. Apart from the yearly licences of £1 per horse-power for cars, there will be issued—to be in force for three months from New Year's Day, from March 25th, from July 1st or from October 1st—quarterly licences each at a rate of 30 per cent. of the full annual duties. Quarterly and annual licences alike must be carried in a holder securely attached to the vehicle in a position in accordance with regulations whereby the licence can be seen from the rear side of the car. There are two types of licence cards, one circular and the other rectangular. Apparently the choice of type is at the option of the user, the general trend of opinion at the moment being evidently in favour of the circular type, which is neater and more in keeping with the badges of the R.A.C., the A.A., and so on. Each licence is printed on a stout paper card of colour according to the period for which it is to run. Thus the annual licence for this year will be in blue. The first quarterly licence will be yellow. The colours for the second, third, and fourth quarterly licences have not yet been settled. The licence has to be exhibited in a conspicuous position on the rear side of the car, being on, or attached to, the wind screen, or on the outside of the fore portion of the vehicle, in line with the driver's seat. It must be contained in a metal holder of weather-proof construction. Types of holders, designed specially to enable the licence to be exposed, have been approved by the Ministry, and are being standardized by the accessories industry.

METHODS OF PROCEDURE.

The first thing the owner of the motor vehicle has to do is to obtain from his local money order office, or from the registration authorities in the area of his domicile—the local postmaster will give the address on request—an application form. Having filled this in, he sends it to the registration authority in his own area, together with a remittance for the requisite amount. This form relates to the registration of his vehicle under the new regulations; it also constitutes the application for the licence, whether yearly or quarterly. Provided the owner takes care to register the letter in which he sends the form his responsibility is practically at an end. If he can prove that a licence, or an application for the same, together with remittance, is in course of post, it is beyond the power of the authorities to make out a case that he has striven to evade the law. Of course, a considerable amount of turning over is being involved at this period by reason of the localizing and co-ordinating of the registration and the licensing authorities, and of the adoption of the principle of local registration. In the case of cars already licensed, and therefore carrying number plates often issued in areas where the car is neither owned nor used, the registration will remain in force when the necessary transfer of particulars has been effected. But all new cars taken into possession from now onwards have to be registered in the district in which the first owner resides, as distinct from the very general practice hitherto, whereby cars have been registered, to the number of thousands, in the district where they have been built. In exchange for the form and remittance the vehicle owner is entitled to receive what is technically styled a continuing document in the form of a registration book, together with a licence card, which has to be placed on the vehicle, as already indicated. By contrast the registration book, which contains the history of the vehicle and is stamped each year—or each quarter, as the case may be—to show at a glance that the fee has been paid, must be kept by the owner in some secure place, but, preferably, not on the car. It may be inspected by the police at any reasonable time. But the owner is not required to carry it with him when motoring on his vehicle, as he is required to carry his driving licence when driving. The registration book is the property of the owner of the vehicle so long as he remains in possession of it. When he sells the vehicle the book passes to the new owner through the one or two—as the case may be—registration authorities concerned. When an owner sells a car he must notify his registration authority and return him the licence and the registration book issued in respect of that car. The local authority will then enter up in the book the date of the transfer of ownership and, on receiving application—direct from the new owner if he is

resident in the same neighbourhood, or, alternatively, from the registration authority in the neighbourhood in which the new owner resides, and to whom the new owner will apply—transfer that registration book, either direct to the new owner, or to his registration authority, which, in turn, will issue it to the new owner after having entered up all the details. In short, the registration book is the history of the vehicle. It remains in possession of the owner of the car for the time being. The complete particulars in it are reproduced and kept permanently in the books of the licensing authorities.

TRANSFERS AND SHORT-TERM LICENCES.

By contrast with former procedure, in the motoring laws which have now come into force the licence primarily concerns, not the owner, but the car. Thus, if the writer takes out a yearly licence for his car to-day and sells his vehicle to the reader in July, the reader, as buyer, having completed formalities, enjoys the benefit of that licence till December 31st, 1921. Hitherto the practice has been that if one sold one's car at any period of the year and bought another vehicle not exceeding the same Treasury h.p. rating, there was no occasion to take out a second licence for the use of the car. Now, however, if, having sold his car—therefore having passed the licence on—the writer wishes to buy a new one in the middle of the year, he must pay another horse-power tax in respect of whatever period of the year remains unexpired. For example, if he wishes to use it from an early period in July until the end of the year, then it will pay him best to take out two quarterly licences, each at 30 per cent. of the rate obtaining for the whole year, so that he would get off with the payment of an aggregate of 60 per cent. for six months' use of the car.

In the case of three-wheelers, this licence must be fixed "in a conspicuous position on the rear side of the vehicle, and visible at all times by daylight, to an observer standing at the rear side of the vehicle—whether the vehicle is moving or stationary."

Forms of application for licences and for the tax are obtainable from any money order office on New Year's Day. It may be pointed out that if the licence is not fixed in the legal position, or if, being so fixed, it is in any way obscured or rendered or allowed to become not easily distinguishable, the person driving the vehicle will be liable on summary conviction to a penalty not exceeding £20 for the first offence, the penalty for subsequent offences being limited to £50. If, however, the person charged proves he has taken all steps reasonably practical to prevent the licence card being obscured, or rendered not easily distinguishable, he will not be liable to be convicted. One does not anticipate that once the new scheme has been running for twelve months its working will be found any more irksome than the old. In fact, it should be rather simpler in face of the provision in the Roads Bill to the effect that in the case of any car to which a registration number has been allotted prior to January 1st, 1921, that number shall be treated as having been assigned to the given car under the new regulations and no new number shall be assigned to such a car. To have proceeded in any other way would have been foolish in face of the fact that, though cars have now to be registered locally, often they will be sold to owners outside the given locality, consequently some cars will always be found about the country carrying number plates other than those of the locality in which their present owners reside and in which they are being used. The new form of taxation does not concern the driving licence, which will have to be taken out, as hitherto, at the price of 5s.

Considering the many minor modifications made week by week, if not day by day, in the details of procedure ordered by the Road Board, when in any doubt on a point it is advisable to inquire at the local money order office or at the local registration office.

The National Association for the Prevention of Infant Mortality will hold its second English-speaking Congress on Infant Welfare in London on July 5th, 6th, and 7th. The following are among the subjects to be discussed: Residential provision for mothers and babies; inheritance and environment as factors in racial health; the supply of milk, its physiological and economic aspects. Further particulars may be obtained from the Secretary at 4, Tavistock Square, London, W.C.1.

British Medical Journal.

SATURDAY, JANUARY 1st, 1921.

GALEN.

CHARLES LAMB, in his list of *biblia a-biblia*, assigned a prominent place to "the histories of Flavius Josephus, that learned Jew," and we make no doubt that had Kühn's edition of Galen (a new book when Elia wrote) come his way, it would have fallen under a like condemnation, being certainly a work which "no gentleman's—at least no physician's—library should be without."

Since the days of Elia there has not been any noticeable increase in the demand for Galen's writings. So far as we know, there is but one London medical library from which Kühn's edition (the only modern edition) can be borrowed, and we have never found any great difficulty in securing a volume there. Epidemiologists, and even statisticians, discover that the fame of Sydenham was not unmerited; nobody has yet proved that Galen was an early biometrician with correct views on the periodicity of disease.

At a recent meeting of the Historical Section of the Royal Society of Medicine Dr. Major Greenwood endeavoured to decant the ancient wine into new bottles. Dr. Greenwood, of course, did not wholly avoid the snare which, as he pointed out in a lecture printed in our columns last year, entangles the feet of most students—the risk of finding in ancient writings what one brings to them. Perhaps his attempt to discern in Galen *De Temperamentis* a Bravais-Pearson correlation surface, smacks overmuch of the Puseyite who, according to Macaulay, proved that the *Pilgrim's Progress* was composed in the interest of Tractarianism. Then, again, one need not go very far afield to discover the secret of Galen's medical dictatorship. In doing so Dr. Greenwood for once forgot to take the cobbler's interest in leather. The explanation is, as Dr. Singer remarked, statistical; more than 50 per cent. of surviving Greek medical literature is the work of Galen; it would have been strange had Galen not dominated an authority-loving posterity. Yet this is not the whole explanation, and, although Dr. Greenwood disclaimed any attempt to reconstitute the personality of Galen, he did succeed in conveying an impression of it which, whether just or not, was vivid.

Freud himself psycho-analysed Leonardo da Vinci; others who, let us charitably suppose, have at least read the works of Freud, have psycho-analysed Wordsworth, Shelley, and even Homer. Galen may be suggested as an admirable subject. Dr. Greenwood pointed out that in Galen we find interwoven the intellectual and moral characteristics of a Greek of the empire, seen at their best in Lucian, at their worst in *Gracculus esuriens* of Juvenal, with those of the great men of Plato's day. We have abundance of epigram, usually spiteful, sometimes witty, much dialectic, the wisdom of Nigrinus rather than of Socrates. But there is something more; something which we admire in Hippocrates. Galen, for all his hair-splitting realism (in the mediaeval sense), preached a doctrine of unity in disease. His theory of procatarxis, his teaching that in the innate structure and functions of the body and the variations imposed thereon by the

atmosphere, by habits of life, by all the phenomena of existence, are to be found the "causes" of disease, is still of value.

Dr. Greenwood pointed out that this philosophy of disease was also embraced by the enthusiasts of the early Victorian epoch. Galen's faith in temperance and moderate exercise, Chadwick's faith in better housing and proper "drains," translate into different dialects the same idea. Galen attached more importance to "seeds of pestilence" and to miasm than did Chadwick; but both agreed in attributing to the totality of conditions a unitary effect. Galen, a nimble-minded Greek, could easily have been taught the bacteriological theory of disease by a traveller on Mr. Wells's time machine. The differentiation of bacteriological strains would have charmed him; he would infallibly have carried it much further than we do. But it would have been altogether impossible to convince him that disease can be conquered by successively or simultaneously immunizing individual citizens against a series of specific "seeds of pestilence." He would have obstinately maintained that to secure a sound body obedience to his principles *de sanitate tuenda* is necessary, and that without such obedience no lasting change in the general level of health can be secured.

Dr. Greenwood argues that Galen had a case, that the epidemiological events of the last few years point to a need for reconsidering our philosophy of disease. We have not to argue that case here, and those who seek from Galen enlightenment in our present difficulties will not perhaps—as Dr. Greenwood for his own part admitted—get so much as they desire. It is, however, a pity that none of the more strictly professional writings of Galen have been translated into modern English. Dr. Brock's edition of Galen on the Natural Faculties (in the Loeb series) gives a good idea of Galen's general physiology. Perhaps one day *De Februm Differentiis*, *De Sanitate Tuenda*, and *De Temperamentis* will also be made accessible.

We cannot live on the classics; Galen will never more be read by medical students even at Oxford. But it is strange that the writings of one who filled so large a space in medical history should be far less accessible than those of any other extant Greek author of his period.

HOSPITAL PROBLEMS.

THE difficulty of finding adequate hospital accommodation for those in need of it is no new thing; it was realized long before the dawn of modern medicine and surgery. Writing in 1752, Fielding said: "The properest objects (those I mean who are most wretched and friendless) may as well aspire at a place at Court as at a place in the Hospital." The necessitous sick are better off nowadays in that respect, but the hospital problem remains with us, and in some ways is more urgent now than ever before. The war aggravated the trouble while obscuring its signs and symptoms. But towards the close of 1919 there began a great stirring of opinion in regard to civil hospitals, and interest has grown during the past twelve months. The financial plight in which most of our voluntary hospitals find themselves has been brought home to the public; and, side by side with that, new ideas about medical charities and their relation to modern ways of life have been taking root in the minds of the public and of the medical profession. That more hospital accommodation is needed seems beyond question, and most people agree that the voluntary system should be reshaped but not destroyed. The problem is how to adapt the

system to meet present-day needs and notions without breaking the spirit that informs it. Dr. Addison, Minister of Health, has said this many times in the House of Commons and elsewhere: once last year he went so far as to declare that no Minister of Health in his senses would set about to destroy voluntary hospitals. We do not doubt his sincerity, but in these times a minister's good intentions are of small account when his department and himself are under the fierce searchlight of the newspaper press, which, for good or for evil, is a force that has to be reckoned with.

The idea of tackling the hospital problem early was praiseworthy, but in the light of what has since happened it seems clear that an error in parliamentary tactics was made: someone blundered, as we ventured to suggest at the time. On August 16th, 1920, just before the adjournment, Dr. Addison introduced into the House of Commons a medley of legislative proposals in regard to housing and incipient mental disorder and to various matters (including hospital provision) having more or less to do with public health. It was entitled the Ministry of Health (Miscellaneous Provisions) Bill, and Clause 11 sought to extend the powers of county borough councils so that they might supply and maintain hospitals, contribute to voluntary hospitals, and maintain Poor Law hospitals within their area. In the interval between the introduction of the bill in the Commons and its summary rejection in the Lords, on December 14th, 1920, this clause came in for a great deal of adverse criticism. It was interpreted by some as the first step towards imposing bureaucratic control upon the hospitals of the country and towards the destruction of the voluntary hospital system. The bill had rather a rough passage through the House of Commons: a number of clauses were dropped during the Committee stage, and Clause 11 was modified. The apprehensions felt by the medical profession in regard to the hospital clause were placed before the Ministry by a deputation from the British Medical Association on November 1st, 1920. On that occasion the spokesmen of the medical profession took their stand on two main principles: the need for central medical consultation on the main grounds of policy, and the need for local medical consultation in regard to the details of local schemes. The Minister, in his reply, expressed the wish, that there were some body representing the profession generally with which general principles could be discussed during the formative stages of any large hospital policy. He agreed further that local advisory committees might well be set up in connexion with schemes for hospital provision. The composition of a central committee representative of the whole medical profession is not easy to determine, but steps have already been taken by the Association to give effect to the hint. Before the bill met its fate in the Lords it was urged upon Dr. Addison by members of both Houses that every effort ought to be made to sustain the voluntary system, and with this end in view he agreed to appoint an independent committee of five to consider the financial position of the voluntary hospitals throughout the country, and to make recommendations thereon at an early date.

The reference to the committee raises questions of the highest moment to the medical profession, more particularly to those attached to the staffs of voluntary hospitals. On July 1st, 1920, when events were not moving quite so fast in the hospital world, the British Medical Association had the foresight to hold a conference during the Annual Meeting at Cambridge to consider the relation of the honorary staffs of

voluntary hospitals to the treatment of State-supported patients. There was a large attendance, and the chairman, Sir Cuthbert Wallace, wisely allowed full latitude for discussion. In the result a resolution was carried with one dissentient, approving the policy of the Hospitals Committee of the British Medical Association in regard to the remuneration of voluntary hospital staffs for work done on behalf of State-aided patients, and directing that the subject should be brought to the notice of the governing bodies of these institutions. On that occasion the general subject of hospital finance was not debated. The outcome of the conference was in direct line with the action already taken by the Association on behalf of members of hospital staffs in the case of the treatment of was pensioners.

The Cambridge conference was followed by others throughout Great Britain, and in that way the attention of those most concerned was drawn to this aspect of the hospital problem. The conference held in London on December 21st, 1920, and fully reported in this week's SUPPLEMENT, had a wider field for discussion and marked a further stage in the shaping of hospital policy. The chairman, Sir James Galloway, described it as the first real interchange of hospital staff opinion upon the problem of finance, and the greater part of the day was given up to this topic. The short discussion on the attitude of members of medical staffs of hospitals towards paying patients may be regarded as a sequel to the Cambridge debate. It is significant of how quickly opinion moves in these times that a proposition rejected at Cambridge when put in bald terms should have been accepted in principle six months later in London. On July 1st, 1920, Dr. Astley Clarke of Leicester moved that the time was ripe for the payment of honorary staffs for all services rendered in voluntary institutions, by way of an honorarium on the percentage basis of the expenses of the hospital. This was lost by a large majority, five only voting in its favour; yet on December 21st Dr. Astley Clarke carried a resolution to the effect that should "decisions be taken which would lead to patients paying, in part or in whole, the hospital maintenance fees, either individually or by some contributory method, or with the addition of rate aid or State aid, or by a combination of two or more of these methods, a percentage of all such payments should be passed into a fund which could be allocated in any manner which the honorary medical staff might determine." Despite some objection to the question-begging adjective "honorary," this resolution was adopted unanimously.

On the main subject of hospital finance the conference in London recorded its faith in the voluntary system as a boon to the public, to medical science, and to the medical profession. The opposition, valiantly led by Dr. Peter Macdonald, numbered four in a meeting of one hundred and fifty. A motion that necessitous persons should continue to be treated free was adopted without discussion. It was further agreed that voluntary hospitals ought not to be subsidized by the local rating authorities, save in so far as payment is made for the examination and care of patients for whom such authorities are responsible. On the other hand, the principle was accepted that in times of financial difficulty the central Government should subsidize voluntary hospitals by way of contributions proportional to the income received by the hospital in question from voluntary and other contributions, such subsidies being made through some central fund. The view that employers and insurance companies should do much more in support of the

voluntary hospitals, to which they owe so much, was accepted. In double harness, as it were, with this resolution, another was passed declaring that patients in voluntary hospitals who are not necessitous should contribute during treatment towards the cost of maintenance. This principle, if applied in the absolute form expressed in the resolution, may have consequences more far-reaching than perhaps all members of the conference fully appreciated. In industrial centres, especially in the North of England, where workmen's contributions constitute 50 and even 90 per cent. of the hospital incomes, it is hardly to be expected that the workpeople would agree to make a weekly contribution during health and also to pay for maintenance during illness. As the Chairman of Council of the British Medical Association pointed out, the fund formed by the weekly contributions, which is now paid to hospital governors, would, under the plan suggested, almost certainly be retained by the representatives of the workmen to pay the maintenance charge made by the hospital.

Upon the question of provision for paying patients in voluntary hospitals the conference recorded its opinion that no fixed rate of payment for professional services to such patients should be laid down, the fee remaining (as at present) an arrangement between patient, family physician, and consultant.

The concluding resolution was a vote of confidence in the Hospitals Committee of the British Medical Association as the convener of such conferences, and an acknowledgement that the questions discussed are as yet far from solution. This acceptance by voluntary hospital staffs of the machinery of the British Medical Association marks the consolidation of a policy from which much is to be hoped in this and coming years. The hospital system of the country is now being remoulded, and it is essential that during this process means should exist, through the organized machinery of the profession, for bringing together the best brains in it for the discussion of the many important problems arising.

CENTENARY OF THE ACADEMIE DE MEDECINE.

The celebration of the centenary of the Academy of Medicine of Paris was formally begun by a solemn ceremony on Monday, December 20th, at 3.30 p.m.; M. Millerand, the President of the French Republic, was in the chair. The President of the Academy, M. Laveran, first read an address; then the new perpetual secretary of the Academy, Professor Achard (who has just succeeded in this office the late Professor Debove), called on delegates to present their addresses. Owing to the large number of delegates (113), of whom Switzerland sent 25, Great Britain 16, Belgium 11, Holland 6, Italy 6, Venezuela 6, the United States of America 5, Denmark 4, Chile 4, and Greece 3, one representative only of each country was called upon to present his address, though England, Scotland, and Ireland were counted as separate countries for this purpose. The Central Empires, it is hardly necessary to mention, were not represented among the delegates. In reply Professor Achard delivered a short but eloquent message of welcome, and, after the Minister of Public Instruction, M. Honnorat, had given an address, M. Millerand dissolved the meeting. On Tuesday morning, December 21st, Professor Vaillard reviewed the part played in the last 100 years by the Academy of Medicine in the evolution of public health, and was followed by M. Hanriot, who commemorated the benefactors of the Academy. In the afternoon Professor Chauffard summarized the work done in medicine by the Academy, dwelling much on Villemin's researches on tuberculosis and Pasteur's epoch-making investigations in connexion with microbial diseases. At 5.30 p.m. the

delegates were received by the Mayor of Paris at a reception given by the municipality at the Hôtel de Ville. On Wednesday morning M. Camus described the influence of the Academy on vaccination, and M. Meillère discharged the same duty with regard to hydrology. In the afternoon the past President, Professor Delorme, gave an exhaustive historical review of surgery in relation to the Academy during the century 1820-1920. The celebrations closed in the evening with a banquet at the Hôtel Palais d'Orsay, with M. Laveran, President of the Academy, in the chair. The cordial hospitality given to the delegates was emphasized by the gift of a beautiful memorial medal, designed by M. Paul Richer.

SILICOSIS AND TUBERCULOSIS AMONG MINERS.

In his annual report for the twelve months ending July 31st, 1919, Dr. W. Watkins-Pitchford, chairman of the Miners' Plithisis Medical Bureau, reports over 32,000 statutory clinical examinations and investigations; in addition the board made 1,400 examinations for military service, and for five weeks they gave their whole time to attendance on patients suffering from influenza during the epidemic. The prevalence of pulmonary tuberculosis, whether "pure" or complicated by silicosis, as revealed at the periodical examinations of 15,000 miners of European descent, was at the rate of 1,141 per 100,000, as compared with 1,267 and 909 for the two preceding years respectively. The prevalence rate of silicosis, whether in its pure form or complicated by tuberculosis, was 5,532 per 100,000, as compared with 5,602 and 5,595 for the two previous years. As ascertained at the periodical examinations, the attack rate of tuberculosis not complicated by silicosis was 255 per 100,000, as compared with 259 for the preceding year. In one case only was pulmonary tuberculosis detected at periodical examination of a person who had passed the "initial" examination of the bureau. The apparent production rate of cases of non-complicated silicosis detected at periodical examinations was 2,480 per 100,000, a figure more than double that of the previous year; it is pointed out, however, that a considerable number of these miners had lately returned from active service, and not all had developed their condition during the year under review. The prevalence rate of tuberculosis in combination with silicosis, as detected at periodical examination, was 869 per 100,000—almost the same as in the previous year. The statistics given refer to persons of European descent; among 172,000 native labourers, of whom 129,000 were employed underground, tuberculosis without silicosis was found in 789 instances, giving the low prevalence rate of 458 per 100,000, while tuberculosis in combination with silicosis was encountered in 378, or 219 per 100,000. It is the unanimous opinion of the bureau that in assisting the formation of a just decision as to the presence or absence of silicosis, and also for the diagnosis of all but the very earliest cases of tuberculosis, it is of paramount importance that a technically satisfactory radiogram should be available. During the twelve months 172 miners were admitted to the wards for observation extending from two to five days. During the 15,000 periodical examinations of working miners of European descent the opinion was formed in 165 cases that the person's health was likely to be endangered by a continuance in underground work; of these, 135 were judged to be in danger of developing tuberculosis, including 102 who were already silicotic; 24 were cases of heart weakness, 2 of chronic malaria, and one each of chronic bronchitis, empyema, cancer, and epilepsy. In view of the observation that tuberculosis affecting the silicotic miner is relatively non-communicable to healthy persons, preliminary experiments were made with the object of detecting a possible diminution in the virulence of the *Bacillus tuberculosis* after it has been propagated in silicotic lung tissues. In guinea-pigs, however, whether the bacilli had been derived from silicotic cases or from the subjects of ordinary

pulmonary tuberculosis, it was found that the animals injected developed tuberculosis with equal rapidity and with the same characteristic distribution.

FLAVOURING AGENTS IN MEDICINES.

THE Insurance Committee for the County of Stirling has proposed to take action in connexion with the routine use of flavouring and sweetening agents in doctors' prescriptions. At a meeting of the Committee on December 16th a letter was read from the Scottish Board of Health in which it was stated that while on the one hand the Board could not refute the argument that medicine made pleasant was more likely to be taken regularly, yet on the other it suggested that the use of flavouring and sweetening agents would tend to foster the drug habit. The Board believed that the average insured person goes to his doctor in order to get well as quickly as possible, and is therefore prepared, as an intelligent person, to obey instructions as to treatment. Though it believed that only a very small minority of patients needed to have medicine made palatable the Board did not suggest that it was possible to discontinue the use of flavouring and sweetening agents entirely; it, however, desired that the considerations set out should be placed before the Panel Committee, together with a reference to the memorandum on the rate of medical remuneration under National Insurance by Sir Clifford Allbutt, President of the British Medical Association, which was submitted early in 1920 to the Arbitration Board. The particular passage quoted from the President's memorandum (which was printed in full in the SUPPLEMENT of February 28th, 1920, p. 46) was as follows: "And, last, not least, the doctor requires to have time for the customs of private practice, namely, instead of curt and dictatorial visits, patient and explanatory conversations, such as to lift the patient out of the pill, plaster, and bottle superstition, and up to a rational conception of the nature of the disease, its prognosis, and the means of its prevention." The Insurance Committee expressed itself satisfied that the Stirlingshire doctors were endeavouring to keep the cost of prescriptions down to the lowest possible figure. But there is something droll in this solemn discussion of the ancient question whether medicines should be nice or nasty. There are some, even among the medical profession, who think that the nastier the medicine the more effective it sometimes is. The President's dictum does not, in fact, deal with the point; Sir Clifford Allbutt was urging an appeal to the patient's reason, for his help in the prevention and treatment of disease. He was not at all concerned to recommend that the pill or potion, when it had to be prescribed, should be nasty.

DIPHTHERIA CARRIERS.

GUTHRIE, GELIEN, and MOSS have undertaken an exhaustive investigation of the diphtheria-carrier problem, and now supplement their observations published in 1912 by results of far-reaching importance as regards the practical significance of the carrier state and the question of how, from the point of view of the community, diphtheria carriers should be dealt with.¹ In February, 1912, a single throat-swab from each of 800 children attending one of the public schools in Baltimore revealed diphtheria bacilli in 85 children, or 10.6 per cent.; a re-examination of the same 800 children three months later gave positive cultures in 69, or 8.6 per cent.; and the number of children yielding positive cultures at either one or the other examination was 144, or 18 per cent. Virulence tests, as shown by injection of cultures into guinea-pigs, a positive result being reported when death occurred with characteristic lesions within four days, were carried out with diphtheria bacilli from 99 cases and 9 were found to show virulent bacilli. From further swabbing of some of these 800 children

15 more carriers were discovered, bringing the total up to 160. Only 11 of these 160 carriers gave a history of having had diphtheria, and none within the previous three years; while under observation none of them subsequently developed diphtheria. Fourteen of the carriers gave a history of exposure to diphtheria at periods varying from one to twelve years previously. Careful inquiry failed to find any example of the disease arising among the contacts of the 160 carriers. In order to determine how long diphtheria bacilli persist in the throats of persons with positive cultures, but without clinical evidence of the disease, 50 of the carriers mentioned above were examined at intervals of two weeks for three months; at the end of this period six only were positive. With the object of throwing light on the question whether or not diphtheria bacilli in the throat can undergo a change in virulence—that is to say, whether virulent bacilli can become non-virulent or non-virulent bacilli become virulent—a remarkable experiment was performed on five healthy persons proved to be free from diphtheria bacilli by daily cultures over a period of two weeks; their throats were then inoculated with a pure culture of non-virulent bacilli, and after that daily swabs were examined for some weeks, then swabs were taken at intervals of a few days for three months, and subsequently at longer intervals for about fifteen months; some of these five individuals became carriers, but none ever showed virulent bacilli or suffered from symptoms referable to the diphtheria bacilli in their throats. A series of observations on the cultural and staining reactions showed that virulent and non-virulent diphtheria bacilli are exactly alike, and can be distinguished only by the toxin-producing power possessed by the virulent bacilli, as shown by the guinea-pig test. The other members of the diphtheria group are readily differentiated from the diphtheria bacilli, and are without any pathogenic significance. The important conclusions from these observations may now be briefly summarized: the diphtheria bacilli in a majority of healthy (that is, not "convalescent" or "contact") carriers are non-virulent; non-virulent bacilli cannot cause diphtheria; there is no proof that non-virulent bacilli can become virulent; and therefore carriers of non-virulent bacilli are not a menace to others or to the community at large, and interference with their liberty is unwarranted. It may be advisable to isolate carriers until the question of virulence of their bacilli has been decided, but, if the culture proves non-virulent, further detention of the carrier is unjustifiable. No doubt time and expense are entailed by the guinea-pig test, and a simpler and less expensive one is urgently needed; but this drawback is less serious than the economic loss and inconvenience incurred by needless isolation of the carrier of non-virulent bacilli. On the other hand, the carrier of virulent bacilli occupies an entirely different position.

THE CAMPAIGN AGAINST VENEREAL DISEASE.

THE commission, consisting of Dr. Rupert Hallam, Mrs. C. Neville Rolfe, and Miss E. O. Grant, which has been sent out by the National Council for Combating Venereal Diseases, with the authority of the Colonial Office, to study the social conditions and the steps to be taken locally to combat venereal disease in the East, has had a warm welcome during its journey across Canada. The Canadian Council for Combating Venereal Disease and the public health authorities took the opportunity which the presence of the commission afforded to conduct a vigorous campaign of instruction, and to enlist public support throughout the Dominion; the assistance given by the press greatly added to the success of these meetings. A large meeting was held at Toronto on November 8th under the chairmanship of the Hon. Mr. Justice Riddell, and a resolution was passed urging that the Ontario Council should be reorganized on the lines of the National Council in Great Britain, so that closer co-operation might be obtained between the Government

¹ C. G. Guthrie, J. Gelien, and W. L. Moss: *Bull. Johns Hopkins Hosp.*, Baltimore, 1920, xxxi, 388-403.

and provincial and municipal authorities. Before the commission left for Hong Kong and other eastern ports it was able to convene a meeting at Victoria of representatives of practically every organization in British Columbia, and a committee was formed to assist the Canadian Council in attacking venereal diseases as a general health problem.

EPIDEMIC HICCOUGH.

DURING the last few weeks the Paris correspondents of the daily newspapers have mentioned on several occasions the prevalence of hiccough there and have noted that the disorder has incapacitated several public men. An account of the symptoms of what has come to be called epidemic hiccough was given by MM. J. A. Sicard and J. Paraf at a meeting of the Société Médicale des Hôpitaux de Paris on December 3rd, 1920, and at a subsequent meeting it was reported that forty cases had been noted during eight days among 3,000 male factory hands at Lille. The malady appears to show a particular affinity for the male sex; of Sicard and Paraf's twenty-seven cases, one only was a female. Although occasionally preceded by a slight degree of muscular stiffness, brachial or cervical neuralgia, epigastric discomfort, or febrile malaise, the attack as a rule appears quite suddenly in persons who are otherwise in good health. Usually its duration is two or three days and the temperature is little raised, if at all, but Netter had one patient whose temperature exceeded 102°; in this case the illness lasted six days. The hiccough occurs in rhythmic crises lasting from half an hour to an hour and a half, and separated during the daytime by intervals of similar duration. During the attack the spasms occur at the rate of six to eight a minute; the crises are not usually frequent during the night, and there is little insomnia. No cases of relapse or recurrence, or of any complication, were noticed. In two cases the cerebrospinal fluid was found to be normal. With regard to treatment, analgesics, including morphine, were often ineffective, but in certain cases the spasms could be inhibited by compression of the eyeball, rhythmic traction on the tongue, or the application of an icebag to the side of the neck. The physicians of Paris appear to have little hesitation in connecting this curious epidemic with that of encephalitis and its myoclonic manifestations. Fortunately, in the cases reported up to December 3rd, hiccough was the sole serious manifestation, and the course of the malady was entirely benign; in view, however, of the polymorphism of epidemic encephalitis, and of its widely different modes of onset, it is right to maintain a certain reserve with regard to the prognosis of epidemics such as the one recorded in Paris. Possibly Sicard and Paraf are right in their conjecture that cases formerly described as hysterical or neuropathic hiccough, and also certain epidemics of chorea major recorded during the Middle Ages, may have been connected with a coincident or antecedent epidemicity of encephalitis.

PRIZE IN OPHTHALMOLOGY.

MR. W. EDMONDS and Miss S. Edmonds, of Wiscombe Park, Colyton, have founded a prize in ophthalmology in memory of their brother, Nicholas Gifford Edmonds, Lieutenant 2nd Black Watch, who fell at Magersfontein on December 11th, 1899. The prize, of the value of £100, will be awarded every two years for the best essay on a subject dealing with ophthalmology and involving original work. The competition is open to all British subjects holding a medical qualification. Subject to certain legal conditions, the management of the prize will be in the hands of a committee nominated biennially by the Medical Board of the Royal London Ophthalmic Hospital, which will select the subject of the essay and elect two examiners. The winner of the prize will have the option of giving a lecture on the subject at the Royal London Ophthalmic Hospital. The Middlemore Prize of the British Medical Association, awarded triennially on very

similar lines, has rendered valuable service to ophthalmology, and many of the Middlemore Prize essays remain standard works. It may certainly be expected that the generous gift now made will also serve as a strong stimulus to original work. There cannot be too many such incentives to break away from routine in professional life, and to stimulate initiative; many men have originality and power of investigation, but from lack of stimulus do not settle down to any definite line of research; the setting of a concrete subject is often all that is required to fire a man to carry out a valuable piece of work. As the subject of the essay will be announced two years before the award, ample time will be afforded for studying the literature, for thorough observation, and for carrying out experiments before sitting down to the actual composition of the essay. By their generous liberality Mr. and Miss Edmonds place the profession under a deep debt; their wish in founding the prize is that suffering may be alleviated, and it may be confidently anticipated that this end will be attained.

THE WAR EMERGENCY FUND.

WE are informed that the Executive Committee of the War Emergency Fund, at its meeting on December 21st, made several substantial grants to defray, in whole or in part, the school fees of the sons of medical men who left their practices to take up commissions in H.M. Navy or Army during the late war, and who, after resuming civil practice, find themselves in temporary financial difficulty owing to their war service. The Committee is prepared to make similar educational grants for the daughters of such medical men. Applications for such grants should be made to the Honorary Secretary, War Emergency Fund, 11, Chandos Street, Cavendish Square, London, W.1.

A BILINGUAL Congress in Radiology will be held in London in the middle of April next. The Congress will last three days, and on each day there will be papers and discussions in each of the three subjects—radiology, electrology, and physiotherapy.

Medical Notes in Parliament.

The Parliamentary Session.

VARIOUS reasons may be assigned why Parliament, in the session just ended, has not fulfilled the high hope of the King's Speech of last February. Perhaps the simplest and broadest explanation may be provided by the psychologist, who would say that the fault lay not particularly in men or measures or circumstances, but in all three—that is, in the inevitable difficulty of quickly reforming habits of mind and procedure which had been set up for the war and temporarily hardened.

This explanation applies to the somewhat jerky way in which Cabinet Ministers in their utterances have dealt with both foreign and domestic policy, authoritatively and unauthoritatively, just as during the war they acted sometimes collectively and sometimes on their own initiative to meet the emergency. It accounts also for the defective working of members of Parliament, who, under the system developed for the war, have had to distribute themselves on various Grand Committees upstairs, like irregular bodies of quicksilver, and have thus been tempted to neglect the House itself. Their attendance in that place has often been poor, and discussions have been left to a few members both for speech and for hearing; so it has happened that the House itself has lost much of its former authority and distinction. As for the measures put forward by the Government, they have evoked the criticism which architects make of transition periods; they have lacked character and strength in gathering up purposes and plans left over from the war, and they have not been fully designed for the new circumstances of peace. What was needed in the change over was leisureed and deliberate thought. Instead, the war habit of mind and the pressure of circumstances have led to an attempt to do too much in the time. Thus, there have been diffused activities and a certain waste of energy

and want of clearness of expression. It must be recognized that this was almost inevitable; but none the less it is desirable that the causes for the very partial success of the session should be frankly faced, so that they may be corrected as soon as conditions permit.

While these reflections cannot be avoided, it is due to the Government to remember that several measures of great importance have been enacted, and that brave attempts have been made to carry through others. In addition, a number of smaller matters have been usefully dealt with in minor bills, and the whole scheme of administration has been in process of gradual revision. Perhaps the Coal Mines Act, although its passage is now almost forgotten, will rank first in value in history owing to the understanding reached between owners, miners, and the State. What will emerge out of the Home Rule Act nobody professes to be able to say; but a bill which is designed to enable the setting up of two parliaments and to rearrange all sorts of relations between Ireland and Great Britain necessarily requires a great deal of care—none the less because the Opposition, disagreeing with the proposal, declined to have anything to do with it. The Agricultural Act involved other delicate matters of settlement between the various interests engaged in the cultivation of the land, and the controversy excited in both Houses sufficiently showed the difficulty of the problem. The Unemployment Insurance Act has proved even a more timely measure than was foreseen by most people while it was being put through. The Extension of Health Insurance Act, the Dyes Act, and the Act to give power to the Transport Minister, all dealt with subjects which at other times would have had a larger place in public attention. Two small bills which certainly deserve mention are that for establishing juvenile courts and the financial provision made to enable pensions for the blind to begin at the age of 50.

A considerable part of the time of the session was, of course, occupied with finance. Mr. Chamberlain has been generally condemned in business circles for maintaining and increasing the Excess Profits Duty, but although the most gloomy observations are made concerning the possible yield, as well as in reference to its effect on trade, the Chancellor of the Exchequer has continued to assert his confidence that one way or another his Budget of next year will give the estimated surplus. It remains to be seen who will prove to be right.

There is no doubt that the lack of co-ordination of Government business, to which reference in these notes has already been made, has had much to do with the misfortunes of Dr. Addison in his ambitious efforts to make the Ministry of Health thoroughly worthy of its purpose. The plain man in the street has been puzzled to know why housing and health, two of the biggest and most urgent administrative affairs, have fallen to the responsibility of a single Government department; but that is due rather to history than intention, and Dr. Addison, until he was recently relieved to some extent by Dr. Macnamara, who has taken up the labour problem in regard to building, has had to bear the full brunt of both affairs. Again, it is an open secret that in respect of the division of time for legislation Dr. Addison was handicapped by other Cabinet arrangements, and that is the reason why he made the error of producing an omnibus health bill, which united opposition without attracting sympathy. The position of that measure has been sufficiently dealt with in these notes, and it need only be said that the appointment of the committee to go into the whole question of hospital finance may be expected at any moment. One of the greatest regrets that must be felt by all interested in health legislation is that the Proprietary Medicines Bill, after having been given slow and considered passage to the Report stage in the House of Lords, failed to get time for progress in the Commons. The hope is that the work that has been done in this connexion will not be lost, but everyone knows that in the Commons this measure of reform will have to meet a good deal of criticism, due to the opposition of various interests.

No review of the session, however brief, can close without a reference to the dark shadow of unemployment. Mr. Lloyd George, in his speech on this subject just before the prorogation, was frank in saying that the measures which were being taken to relieve it could only be in the nature of palliatives. Recovery must depend largely on the restoration of peace conditions in the world and on the awakening of the people of this country to the fact that our trade can be recovered, even in those circumstances, only by increased industrial activity and by a more economic production. The wage does not matter; what does matter is the value given for it; and at the present time this, in many cases, is exceedingly unsatisfactory, and threatens to leave us behind in the world competition.

The Dentists Bill.

We summarize here the principal provisions of the Dentists Bill now before Parliament. The bill is concerned only with regulations to prevent unqualified practice; no extensions of treatment are contemplated.

Section I, which is to come into operation from one to two years after the commencement of the Act, provides that no person who is not a dentist registered under the Dentists Act of 1878 may "practise or hold himself out, whether directly or by implication, as practising, or as being prepared to practise, dentistry for fee or reward"; excluded from the application of this section are (1) dental practice by a qualified medical man; (2) extractions performed by a registered pharmaceutical chemist or registered chemist and druggist (provided that no local or general anaesthetics are used, that the case is urgent, and that no qualified medical practitioner or registered dentist is available); (3) minor dental work performed (in approved conditions and with the supervision of a registered dentist) in private dental services. Section II authorizes the establishment of a Dental Board with perpetual succession and a common seal; the first Board is to be composed of a chairman appointed by the Privy Council, three lay members appointed by the health authorities of England, Scotland, and Ireland respectively; three persons appointed by the General Council; and five persons who are, or have been, engaged in the practice of dentistry. Of the last-named group one must be a person who before the passing of this Act was not registered.

Section III establishes the right of admission to the Dentists' Register of certain persons (of good character, and having attained the age of 23) who are not at present qualified. These include (1) persons who for five years before the commencement of the Act engaged as their principal means of livelihood in the practice of dentistry in the British Isles, or who not less than one year before the commencement of the Act were admitted to the membership of the Incorporated Dental Society; (2) persons having for five years been principally occupied as dental mechanics, provided that within two years they pass the prescribed examination in dental mechanics, and within ten years thereafter they pass (after the prescribed training) the prescribed examination in dentistry; (3) any person who within two years passes the prescribed examination in dentistry and whose principal means of livelihood at the commencement of the Act was the practice of dentistry, will be entitled to admission to the Register; (4) the same is true of a duly registered chemist who was in "substantial practice" as a dentist, and whose practice included "all usual dental operations," provided that he gives an undertaking that within five years from the date of his registration he will cease to carry on concurrently the occupations of chemist and dentist. In the case of ex-service men the Board may dispense with any of the requirements of this section if the public interest is not thereby prejudiced. Section IV lays down that a body corporate may carry on the business of dentistry if it carries on no other business, and if all the directors, managers, and operating staff thereof are registered dentists. A person who for five years has acted as director or manager of a body corporate engaged in dentistry is entitled, however, to be entered in a list kept by the Registrar especially for the purpose of this section—such a person shall be entitled to act as director or manager, but shall not by virtue of this registration be entitled to practise dentistry. Every body corporate carrying on the business of dentistry is required to transmit annually to the Registrar of the Board full descriptions of the directors, managers, and operators. Sections V to X define the powers and duties of a dental board, and authorize the transference thereto of certain powers and duties of the General Council under the Dentists Act of 1878 and the Medical Act of 1886; erasures from the Register are to be made by the General Council acting after consideration of the report of the Dental Board.

Medicines for Panel Patients.—Mr. Casey asked, on December 23rd, 1920, whether the Minister of Health was aware that Dr. Ritchie and Dr. Allott, of Hoyland Comm., near Barnsley, had been informed by the Wakefield Insurance Committee that they were supplying or prescribing a quantity of medicine to panel patients which was far too expensive; that Dr. Allott had been surcharged £15 for this alleged offence; that in consequence of the restrictions imposed, the doctors had notified persons on their panel that in future they would be unable to supply or prescribe the quality of medicine which, in their opinion, was necessary to many cases under their care; and what action he proposed to take to ensure that medical men were able properly to discharge their duties to panel patients by being permitted to prescribe and supply that which was essential to a speedy recovery irrespective of the cost of the drugs used. Dr. Addison replied that his attention had not been previously called to this case, and he was causing inquiry to be made. He could inform Mr. Casey, however, that medical benefit under the Insurance Acts included the provision of "proper and sufficient medicines," and no doctor could be surcharged in respect to prescribing unless the character or quantity of the drugs was "in excess of what may reasonably be necessary for the adequate treatment of his insured patients," and then only on the report of the Panel Committee consisting of doctors elected by the insurance practitioners of the area. Any local decision to surcharge a doctor was subject to appeal to the Ministry of Health.

England and Wales.

THE PEOPLE'S LEAGUE OF HEALTH.

As a result of a meeting held by the People's League of Health at the Cardiff City Hall on December 15th, under the chairmanship of the Lord Mayor, at which Sir Bruce Bruce-Porter, Dr. Eric Pritchard, Dr. Mary Scharlieb, and Dr. E. H. Stancomb, representing its medical council, were the speakers, a committee was formed to establish the work of the League in Wales. Among those organizing the Welsh Branch are: Dr. Edgar Collis, Talbot Professor of Preventive Medicine, Welsh National Medical School; Dr. Ewen J. Maclean, Chairman of the Cardiff Insurance Committee; and Mr. D. W. Evans, Director-General of King Edward VII Welsh National Memorial Association. The committee, in expressing its very high appreciation of the aims and objects of the League, considers the present moment singularly opportune for the furtherance of the campaign undertaken by the League, particularly in the direction of developing a public demand for health legislation.

MEDICAL TREATMENT OF LONDON SCHOOL CHILDREN.

The London County Council, on December 21st, agreed that for the year from April, 1921, to March, 1922, the allowances to hospital committees and school treatment centres in respect of the services of surgeons, doctors, and anaesthetists employed in the medical and dental treatment of school children under the Council's scheme, should be at the rate of £80 a year (instead of £70) for one half-day of two and a half hours' duration a week, and that the dentists' allowances be £65 a year (instead of £50 to £55) for the same time. The allowance to nursing associations in connexion with the treatment of minor ailments is to be at the rate of £175 a year (instead of £150) for the equivalent of the service of each full-time nurse, including her travelling expenses and the drugs and bandages and other necessities used in treatment. Six additional minor ailment centres and six additional half-time dental centres are to be set up. In the event of the necessity of calling in a local medical practitioner to see children at their homes as a result of treatment performed at the school treatment centres, the committees of the centres are to be responsible for the payment of doctors' fees, such fees to be reimbursed to the committees by the Council. The arrangements sanctioned for 1921-22 provide for the treatment of 32,620 cases of eye defects (as against 31,645 for the present year), 18,110 ear, nose and throat cases (against 15,845, the increase being due to the fact that some hospitals have refused to allow school children to attend their aural departments), 53,350 cases of minor ailments, 118,140 dental cases, and 2,628 ringworm cases, each representing some 10 to 15 per cent. increase upon the figures for the present year. The cost of all these arrangements is estimated at £90,715, an increase of £19,000 upon the cost for the present year, and of this increase £8,360 represents increased salaries of medical practitioners and dentists. The proposed payment compared with pre-war rates shows an increase of 60 per cent. in the salaries of doctors, and 50 to 60 per cent. in those of dentists.

Scotland.

HIGHLANDS AND ISLANDS MEDICAL SERVICES.

THE following letter has been issued by the Scottish Board of Health to practitioners serving under the Highlands and Islands scheme:

"I am directed by the Board to refer to their Circular Letter of July 13th last and to inform you that, in view of the representation made to the Board by the Highlands and Islands Subcommittee of the British Medical Association, and after negotiation with the Treasury, it has been decided that the revised scale of fees set out in the letter referred to above should come into effect on January 1st, 1921.

"The following is the detailed statement of the fees that may be charged on and after the 1st proximo to the classes of patients defined in Article 3 of your Agreement with the Board:

"(a) In ordinary cases the fee shall not exceed 5s. for the first visit, and 3s. 6d. for each subsequent visit in the same illness.

"(b) In midwifery cases the maximum fee chargeable shall be £2 2s., including any subsequent visits that may be necessary; and

"(c) Fees as specified below may be charged for certain special services—namely:

Service.	Fee not to exceed— £ s. d.
1. Operation requiring general anaesthetic ...	2 2 0
2. Fee to anaesthetist ...	1 1 0
3. Operation requiring a local anaesthetic ...	1 1 0
4. Abortion or miscarriage ...	2 2 0
(or £1 ls., according as general anaesthetic is or is not required)	
5. Setting of fracture ...	1 1 0
6. Reduction of dislocation ...	1 1 0

"In all cases under head (c), except (2), the fee is intended to cover two subsequent visits."

Ireland.

ULSTER MEDICAL SOCIETY.

THE second meeting of the session was held in the Medical Institute on November 18th, with the President, Dr. Thomas Houston, in the chair. Mr. Crymble read a paper on obstructions of the alimentary tract. The paper was illustrated by x-ray slides, from a selection of his own cases, thrown on the screen, and dealt chiefly with the more disputed aspects of abdominal affections, such as ileal stasis and mobile caecum.

The third meeting was held on December 2nd. Dr. W. J. Wilson, professor of hygiene and public health, Queen's University, Belfast, opened a discussion on present-day problems in public health; he dealt with the Ministry of Health Act, 1919, the interim report of the English Consultative Council on medical and allied services, and finally urged the Ulster practitioners, in view of the near approach of an Ulster parliament, to organize and see to it that any scheme for the prevention and treatment of disease should have their imprimatur. Dr. Williamson, chairman of the Public Health Committee, Professor R. J. Johnstone, Dr. H. W. Baillie, superintendent medical officer of health for Belfast, Dr. W. Burns, and Dr. Gardner Robb joined in the discussion. Mr. A. B. Mitchell moved, and Dr. Trimble, principal tuberculosis officer for Belfast, seconded, that medical inspection of children should be adopted. Dr. McKisack proposed, and Mr. A. Fullerton seconded, that a public health committee of the society be formed. Both these resolutions were passed unanimously.

The fourth meeting of the session was held on December 16th. Major J. A. Sinton, V.C., M.D., I.M.S., was elected an honorary fellow. Dr. St. George, Lisburn, read notes of an unusual case of arsenical poisoning. Mr. T. S. Kirk read notes on two rare tumours of the small intestine, and demonstrated sections of voluntary muscle showing the changes produced by contusion. A public health committee of seventeen members was elected.

Honour to Major J. A. Sinton, V.C.

The president of the society (Dr. Thomas Houston) and Miss Houston were at home to the fellows and members and their wives on December 18th, 1920, at the Medical Institute, Belfast. The event of the evening was the presentation of the certificate of honorary fellowship of the society to Major J. A. Sinton, V.C. The certificate is in the form of a triptych bound in Russian leather, ornamented by charming water colours of the Queen's University, the Royal Victoria Hospital, the Medical Institute, with reproductions of the Victoria Cross and the Russian Order of St. George, and the crests of the Indian Medical Service and of the Ulster Medical Society. It reads as follows:

"This is to certify that Brevet-Major John Alexander Sinton, V.C., M.D., D.P.H., Indian Medical Service, has been elected an Honorary Fellow of the Ulster Medical Society in appreciation of the conspicuous gallantry and devotion to duty which have earned for him the greatest distinction which a British soldier can obtain—the Victoria Cross for valour."

In presenting the certificate, Dr. Houston spoke of the graceful act of recognition of a doctor's courage by Sir William Whittla, who, when he built the Belfast Medical Institute, installed a beautiful window in memory of Dr. Smyth of Burtonport, co. Donegal, who lost his life during the typhus epidemic at Arranmore. He then referred to the specific act which gained Captain Sinton the V.C. at

Orah ruins in Mesopotamia in January, 1916. Major Sinton, in reply, thanked the Society for the honour bestowed on him, and spoke in glowing terms of the good work done by the civilian doctors temporarily in the army during the war.

Correspondence.

HOSPITAL STAFFS AND PAYING PATIENTS.

SIR,—Having been present at the conference of representatives of hospital staffs on December 21st, 1920, but unable, in spite of two attempts, to catch the eye of the chairman, I venture here to put forward that criticism of the Leicester motion which I was unable to utter in the hall. That motion seemed to me to spoil an otherwise excellent meeting. Voluntary payment by a patient of a fraction of the cost of his bare maintenance might, indeed, furnish argument for raising the salaries of those officers who are concerned with this department; never before has it been excused for exaction of a fee by the honorary staff. The motion is, in fact, far too comprehensive, it was not adequately studied, it is calculated to raise a wide discussion between the staff and their committee, and it deals a deadly blow to that voluntary system which the meeting pledged itself almost unanimously to support. I had previously forwarded to the Medical Secretary, and endeavoured in vain to move, an amendment as follows:

The honorary medical staffs of voluntary hospitals should treat without charge all hospital patients except (1) those on behalf of whom payment is made out of rates or State funds; and (2) those who, in the opinion of the Hospital Committee, are able to contribute a sum beyond that required for maintenance, and who are definitely accepted on that understanding as paying patients by that committee.

I claim for this amendment that it emphasizes the primary duty of an honorary staff, yet leaves them liberty to charge fees in certain cases which are clearly definite. Other classes might be added in great industrial centres, but, in absence of definition, there will be much scope for disagreement. At the Royal West Sussex Hospital we have, until this year, been solvent on the voluntary system, and hope to recover this position without special rate or State aid. The secretary asks every patient, or those responsible for him, to subscribe something, if he can afford it, according to his means. We do not yet take "paying patients," though we meditate doing so. The patients are not of that class, and the honorary staff have no desire to share in these voluntary maintenance fees. No doubt many other hospitals staffs are similarly minded, yet the Leicester motion would compel them to do this thing. Now the honorary character of the staffs of hospitals has hitherto been of the utmost assistance to their committees in raising voluntary subscriptions and donations; if these officers are to be paid for nearly every patient, clearly they must drop altogether the title "honorary," the consequences to the funds of hospitals will be quite disastrous, and the relation of the staff to the still "honorary" committee will be radically altered, and that entirely for the worse. It is idle to plead that this payment will be small, and to call it an "honorarium." The sum may or may not be small, experience has shown that such demands are apt to grow, but anyhow the principle involved is great, and it is certain that committees will not regard as "honoraria" sums extorted from them against their will as a commission on the funds which they receive.

Equally futile is the plea that this money may be devoted to various admirable purposes. Precisely the same excuse was advanced before appropriating fees due from county councils, yet what fraction of those fees has been assigned to such aims? I do not blame the staffs for pocketing the money duly earned, but it had been better to have put forward no other intention from the first. Such programmes will hardly gain credence a second time, when already speakers, quite unblushingly, counted their unhatched chickens for distribution among junior members of the staff. Yet, ethically, how can the staff, who do nothing for maintenance as distinct from treatment, levy toll on sums voluntarily subscribed, whether by patient or other party, for the former purpose? I would prefer to this the frank condemnation of the whole voluntary system

so ably urged by Dr. Peter Macdonald. The logic of his speech was admitted to be unquestionable, but his motion was rejected almost unanimously on the score of sentiment. Yet this same conference, shortly after, by a majority almost equally overwhelming, approved the motion of Leicester, crudely unsentimental, indeed mercenary as it was, on the score of logic! I am, etc.,

Chichester, Dec. 25th, 1920.

G. C. GARRATT.

STASIS AND THE PREVENTION OF CANCER.

SIR,—In his presidential address to the Hunterian Society, reported in your issue of December 25th, 1920, Dr. Jordan refers, for the second time in three months in the columns of the medical press, to one of my "medical notes" which appeared recently in *St. Bartholomew's Hospital Journal*, and criticizes the note adversely. I refrained from replying upon the former occasion because Dr. Jordan placed me in an obvious dilemma: he spoke of me as a "well-known physician," but did not name me; nor does he name me now. But this second and fuller reference invites a brief rejoinder, and I make it in the assurance that Dr. Jordan is as much mistaken in his compliment as I believe him to be in his criticism.

Dr. Jordan says that I wrote "somewhat" as follows—the note was quite short, so that it puzzles me to understand why it should not be quoted exactly—"Cancer of the stomach comes generally 'out of the blue,' with no preceding history of gastric trouble." Although that is not what I said, it is certainly what I meant, and Dr. Jordan's "argument" by no means leads me to disavow it. His argument resolves itself into a simple statement that "radiological investigation reveals incontrovertible evidence of long-standing disorder." Then follows the recital of the case of "a lady," suffering from gastric cancer, who, on "careful questioning," admitted that "she had always been inclined to biliousness and constipation," and whose examination revealed "an enormously elongated pelvic colon," with "a caecum firmly impacted in the pelvis," and "filled with hard faecal masses firmly pressed into the wall of the rectum." The reference which such a state of things bears to the "preceding history of gastric trouble," which I said was not usually present in cases of gastric cancer, is not very clear.

When I wrote the note referred to I had in mind only my own experience. On reading Dr. Jordan's second somewhat scornful criticism I turned up the subject in some standard articles by really well-known authorities, to find (as is so often the case) that there was nothing at all original about my "note." I append the first four references which I came across. "It is not probable that previous disease has any influence whatever in the causation of (the) cancer" (Osler). "There is no evidence that chronic indigestion leads to cancer of the stomach" (Hale-White in *Albutt's System*). "It (that is, the cancer) frequently happens in those who have been hitherto quite healthy, and is not determined by any previous disease" (Frederick Taylor). "There is no definite information which leads us to suppose that gastritis leads to carcinoma; in fact, in a large proportion of cases the development of cancer is almost sudden in the midst of complete health" (Charles F. Martin in *Osler and McCue's System*). I did not proceed further with my researches into the literature of the subject.—I am, etc.,

London, W., Dec. 26th, 1920.

THOMAS HORDER.

THE MINISTRY OF HEALTH AND THE PROFESSION.

SIR,—A section of the lay press is still continuing its attacks on the Ministry of Health by methods such as those on which you commented in your leading article of December 4th. In so far as this represents a genuine attack on the policy of the Government or the methods of the Minister the politicians concerned may be left to look after their own case. But it becomes evident that there is, as you hinted in your article, an attempt, influenced mainly by the tactics of party warfare, to undermine the position and machinery of the Ministry itself, and to discredit those of our own profession who are attached to it, and who, as civil servants, are precluded from making their own reply. In this respect the medical profession, as the custodian not merely of its own reputation and status but also of the interests of the community in relation to

health, is vitally concerned with the controversy, and it is to be hoped that the Association at least will hasten to make its influence felt.

The profession, with the Association as its mouthpiece, was largely instrumental in securing the establishment of the Ministry, in defining its objects, and in determining its powers and its character. We succeeded in impressing on the Government and on public opinion that the care of the health of the whole community was matter for a first class department of State, that in such a Ministry the status and power of the medical side was at least as important as that of the lay side, and that only by the complete, or almost complete, unification of the health administrative service could ultimate success be assured. The provisions of the Act establishing the Ministry, and the arrangements made in building up its organization and personnel, secured these things, as it seemed, on a firm foundation. In Sir Robert Morant and Sir George Newman, given equal status in the Ministry, the public had servants capable of formulating a health policy for the country which, though it might take decades to carry out, and however it might be modified by adequate professional and public discussion, would be such as could not fail to secure in the long run those national results for which the profession has long been striving and the enlightened public aspiring after. These results are now in real danger and even the basis is becoming insecure.

So to limit the powers of the Ministry and so to narrow its possibilities as to reduce it to the level of a secondary department; so to subordinate its medical side as to place it in a position of inferiority to the lay administration; so to bolster up the isolated medical work of other Ministries as to prevent the unification of national health administration under one central body, appear to be the objects aimed at. I judge, however, that if there is one thing which the medical profession will not tolerate, it is a recrudescence of the old situation in which medical and health matters languished under the Local Government Board and half a dozen other departments, where the representatives of the profession were for the most part the scullions of an unenlightened bureaucracy mainly interested in other concerns.

The health of the nation is a big enough affair for a first-class Ministry. It has been part of our policy that other matters should go, as some have already gone, from the Ministry of Health. It is part of our policy, too, that as soon as may be the medical side of the Poor Law administration shall be separated from the purely assistance side, that the health work of the Ministry of Pensions and of the Board of Education should be treated as integral parts of a unified health administration. In a Ministry of this type it would necessarily follow that public health would be one of the prime concerns of the nation, and that the medical profession would take its proper place in formulating, guiding, and carrying out a considered national health policy. Already the masterly memoranda and reports of Sir George Newman and the reports of the senior medical officers under him, have shown us in outline a policy which, though in many respects not immediately practical because of financial and other considerations, demonstrates a grasp of the relationship between medical education, preventive medicine, and curative medicine, between the work of the general practitioner as the base of all and that of the specialist, the research worker, and the administrator as his essential helpers, such as had never yet been placed before the profession and the public.

It is a calamity that at this early stage of its life the work of the Ministry, after the tragedy of the death of its great first secretary, should be hindered by the reluctance of health workers in other departments to associate themselves with it, should be prejudiced by the imperfect methods of the first Minister nullifying his excellent intentions, and should now be stultified by some of the important conclusions and suggestions of its medical side being blocked even from consideration by the action of lay administrators and political wire-pullers.

Again, may I urge the Association and the profession to exert all the pressure that they can towards supporting and completing the reforms on which the national health and well-being so absolutely depend?—I am, etc.,

Hornsey, Dec. 20th, 1920.

H. B. BRACKENBURY.

X RAYS FOR RINGWORM; THE RISK OF BALDNESS.

SIR,—The increasing number of claims against medical practitioners in respect of permanent alopecia following upon the treatment of ringworm of the scalp by x rays renders it desirable that those who may have occasion to use that method of treatment should warn the patient's parents of the possible after-effects.

The violent reaction which occasionally follows even minimum doses of x rays, in spite of all precautions, is otherwise apt to create a suspicion of overdosage or negligent technique, and give rise to claims which might have been avoided by a preliminary word of caution.—I am, etc.,

JAMES NEAL,

General Secretary, Medical Defence Union, Ltd.

4, Trafalgar Square, London, W.C.2, Dec. 23rd, 1920.

THE RISKS AFTER OPERATION FOR TONSILS AND ADENOIDS IN OUTDOOR CLINICS.

SIR,—I was pleased to read Mr. E. Watson-Williams's article in the JOURNAL of December 11th and grateful to him for having brought forward this important subject.

All are agreed that the removal of tonsils and adenoids is an operation by no means devoid of post-operative sequelae, and yet for years the practice of their removal in the out-patient clinics has persisted. The lack of in-patient accommodation has been given as a reason for this unscientific and in many cases dangerous procedure, but do we really consider that this justifies the performance of the operation at all under such conditions?

I would go further and say that no hospital should undertake these cases unless it can provide some sort of after-care and treatment. Tonsils and adenoids are the causative factors in so many derangements of the ear, nose, throat, and of general development, that their removal under proper conditions is of primary importance.

No operation gives such speedy good results if performed thoroughly and in suitable surroundings, and *au contraire*, I might say no operation has been the cause of so much disrepute because of inefficient removal and after-care.

Holding these views, and having repeatedly received just letters of complaint from parents, I have recently approached the board of management at Ancoats Hospital, with the result that a few beds have been set aside in an observation ward, so that these cases can be under observation for at least twenty-four hours.

I admit that twenty-four hours is little enough, but it at any rate allows the child to recover in a good measure from the effects of the anaesthetic and operation, permits of the observation and treatment of haemorrhage, and further, the child can return home during the daytime rather than in the night air.

In conclusion I would urge that hospitals undertaking these cases accept their responsibilities, and try to put this operation on a more scientific footing by providing efficient accommodation for temporary after-treatment or observation.—I am, etc.,

F. HOLT DIGGLE,

Honorary Aurist and Laryngologist to Ancoats Hospital, Manchester, and to the Manchester Board of Guardians.

December 20th, 1920.

VENEREAL DISEASE PROPHYLAXIS.

SIR,—Dr. H. B. Gladstone's letter on this subject in your issue of December 11th, 1920, entirely ignores the problem of the unchaste as it exists at the present moment. He relies on such phrases as "I do not doubt" and "it is probable" to carry conviction, and proposes to leave his so-called "vicious men" in ignorance of simple knowledge that would almost certainly prevent them contracting horrible diseases that not only may cause them much misery and pain, and perhaps an early death, but which they may also hand on to their future wives and children. I claim that such conduct is false to any ethical code.

I wonder whether Dr. Gladstone realizes the proportion of young men that he thus proposes to sacrifice to a cruel blind puritanical bias? Certainly half the adult unmarried male youth of this country, probably much more than half. The section of the community that would be included in Dr. Gladstone's "vicious" class would certainly contain the majority of those who preserved our country's freedom in many hard fought fights by sea and land during the late

war—men who were ever willing to make the supreme sacrifice at the call of duty. To say that such a hero is "vicious" because he has occasionally been carried away by his virile and natural appetite is a monstrous calumny.

It is only possible to pity the "morally strong" section of Dr. Gladstone's classification, whose "high moral tone" "you cannot fail to weaken" by teaching that disinfectants do really disinfect.

That "the moral fibre of the nation would be undermined" by a knowledge that the occurrence of venereal disease could be prevented in men by the immediate application of a solution of potassium permanganate 1 in 1,000, nobody but a very few fanatics can be so bold as to state as a serious proposition, whereas the converse, that the health of the nation would be greatly improved by such knowledge, can hardly fail to be admitted by those who have attempted an exhaustive study of the subject.

All will agree in the value of such societies as the Alliance of Honour for keeping well taught and well disciplined youths and maidens in the paths of sexual morality, and all will wish every success to similar organizations for educating the child and adolescent in self-control. But what about the incontinent *a tult of to-day*? Is he to be permitted to contract and pass on an infection that can be prevented by immediate disinfection? Is scientific knowledge that can prevent to be withheld for a generation until purity leagues have had time to endeavour to prove results—results that "it is probable" will be negative?

The point is whether a possible but uncertain slight increase in clean sexual licence would be a worse thing for our country than the present terrible plague of venereal disease, which is increasing, and which, as one of the first of killing diseases, is filling our lunatic asylums, our blind schools, and our hospitals, and is accountable for more distress of mind than all other diseases put together.

The note published by the Medical Women's Federation in your issue of December 18th, 1920, appears to be entirely uncalled-for, as I believe that every member of the Society for the Prevention of Venereal Disease will agree with their headings "(a), (b), (c), (d)"; but as no one previous to this note, so far as I am aware, has ever raised such an ugly bogey, why raise it only to knock it down with so much energy?

The "directions for women" are "issued only by request" by the Society for the Prevention of Venereal Disease at my discretion as the honorary secretary, and are *not* issued broadcast; they are intended for the use of prostitutes, and for distribution by medical women and health workers in touch with prostitutes, either professional or amateur.

The policy of the Society for the Prevention of Venereal Disease is clearly stated in the first affirmation of our letter in your issue of December 4th, 1920, emphasizing "the efficacy of immediate self-disinfection in the male as a prevention against venereal infection and the possibility of almost eradicating these diseases by this means."—I am, etc.,

London, W., Dec. 23rd, 1920.

H. WANSEY BAYLY.

SIR,—As a medical woman and a member of the executive committee of the Society for the Prevention of Venereal Disease, I wish to protest most strongly against the communication by the Medical Women's Federation which appears in your issue of December 18th, 1920. It is calculated to give an utterly wrong impression of the aims and methods of the Society for the Prevention of Venereal Disease; only entire ignorance of the policy of the society can explain or excuse this extraordinary communication.

It is regrettable that a body of educated women should allow themselves to be involved in so serious a controversy without first verifying the accuracy of their information.

It is true that the "note" issued by the Federation does not say in so many words that the paragraphs marked "(a), (b), (c), (d)" are criticisms of the instructions issued by the Society for the Prevention of Venereal Disease, but there is no other interpretation possible. On behalf of the Society I repudiate the suggestions put forward in these paragraphs. The references to instructing young boys and girls even before puberty, and those that refer to teaching women—not even excepting a bride—to regard their husbands as possible sources of infection, are alto-

gether unjustifiable and revolting. The Society has not issued any instructions capable of such interpretation, nor does it propose to do so.

The question of contraceptives does not concern us here, since the information on immediate self-disinfection given by the Society is for the use of men, and for those women who, by reason of their mode of life, tend to become a source of great danger to the community. Such women do not, as a rule, become mothers, nor is it desirable that they should, since their offspring are not likely to become good citizens, or to add to the health of the nation.—I am, etc.,

London, W., Dec. 21st, 1920.

J. LORIMER HAWTHORNE.

MUSCLE RE EDUCATION IN INFANTILE PARALYSIS.

SIR,—From the controversy in the BRITISH MEDICAL JOURNAL under the above heading one gets, I think, a good example of how easily discoveries are lost sight of and after some time rediscovered. Several writers have shown beyond doubt—particularly Dr. Cyriax—that the principles and practice of muscle re-education in infantile paralysis is no new discovery born by the war, as proposed by Dr. Mackay, but has been known and practised by the Swedish school for many years. This may be put on the credit side for the Swedish school, and needs no further comment, except that one would have wished for the publication of their principles to have been kept abreast with modern investigations and findings.

When, however, Dr. Cyriax, in your issue of December 11th, states that "splinting is not essential in the treatment of infantile paralysis," and "that during the last seventy years the Swedish school have treated this disease without splinting," I for one, as a pupil of that school, must emphatically protest, as I entirely disagree with that view. Further, I do not believe Dr. Cyriax is voicing the opinion of the main bulk of the Swedish school when he makes that statement, but is rather giving the opinion of a minority with extreme views on the subject. If he was, I think it would be most regrettable, as it would show that in spite of rational and advanced views on one hand, they would have shut their eyes to other therapeutic measures of equal importance and ignored the teaching of sound physiological principles which investigation and experience have shown beyond doubt to be correct. Moreover, it is indeed difficult to understand this aversion in some quarters to splinting in bad cases, as the physiological reason for splinting is closely allied to the guiding principle in re-education of paralysed muscles. Take, for example, the case of drop-foot from paralysis of the anterior tibial group of muscles. On the one hand the splint, by bringing about what might be called a passive shortening of the dorsiflexors and stretching of the antagonists, mechanically keeps the foot in a position the active maintenance of which will ultimately constitute complete recovery of the now paralysed muscles. On the other hand, the same position is used as a starting-point for re-educative movements. With this the Swedish school, as voiced by Dr. Cyriax, seem to agree. Now, however, comes the difference. The modern surgeon, who generally favours manipulative treatment, including re-educative movements, removes the splint for that purpose, being careful, however, not to permit, even for a short while during treatment, the foot to hang limp, in order to prevent any overstretching of paralysed muscles. Dr. Cyriax in using the same treatment, but by applying no splint in the interval, permits the foot to hang limp all day and all night, and only during treatment once or twice a day brings it up to the position he hopes the muscles themselves will be able to maintain one day.

If "the rule of the Swedish school has always been to place the affected limb in that position from which the greatest sign of muscular activity were obtainable," why, may it be asked, is not this position artificially maintained during the twenty-three hours of the twenty-four when the limb is left to itself and no treatment is being given? The individual muscle fibre, just recovering its tone, must surely find a great relief in being spared the irritating influence of being overstretched. Why should not this relief be given continuously, instead of only for a short while during the day? If good results have been obtained without splints, one can only infer that those cases were

particularly favourable to recovery; everybody of experience knows, of course, that some cases will recover without any treatment at all, and often in spite of what is being done to them; this is Nature's kind way. It is the severe cases that should serve as a test, and who but Dr. Cyriax will deny that in these cases a combination of splinting with physical and re-educative methods will quickest lead to recovery where recovery is possible?

I cannot believe that the foremost originator of the movement cure meant other therapeutic methods to be cast aside as not being worth considering; if he did he made, as far as I can see, a serious mistake, which it behoves his followers who know better to correct. The Swedish treatment will lose nothing by being used in conjunction with other methods; on the contrary, it will gain more professional, as well as public, confidence; and what is still more important, the patients will derive benefit from the intelligence of several brains instead of only one.—I am, etc.,

London, N.W. Dec. 13th.

C. WESTMAN.

TUBERCULOUS MILK.

SIR,—I have been requested to send you the following resolution for publication, which summarized a discussion of sixteen tuberculosis officers and institution superintendents:

That this conference of the medical staff of the Welsh National Memorial Association unanimously affirm as their view that the distribution of milk containing tubercle bacilli is fraught with danger to the lives and health of children consuming it, and that the hypothesis that tubercle bacilli consumed in milk may produce a degree of immunization is no reason for the abatement of any efforts directed towards producing a tubercle-free milk.

—I am, etc.,

JAMES C. GILCHRIST, M.D.,

Welsh National Memorial Association, Honorary Secretary.
Tuberculosis Institute, Cardiff.
Dec. 21st, 1920.

Universities and Colleges.

UNIVERSITY OF OXFORD.

At a Congregation held on December 17th, 1920, the following medical degrees were conferred:

B.M.—C. K. J. Hamilton, W. F. Skaife, J. T. S. Hoey, I. Harris.

UNIVERSITY OF CAMBRIDGE.

At a Congregation held on December 18th, 1920, the following medical degrees were conferred:

M.D.—A. L. Sutcliffe.
M.B., B.Ch.—F. Moor, W. D. Newcomb, H. R. Pollock, G. E. Spicer,
E. W. Todd, A. C. Halliwell, W. S. R. Thomas.
M.B.—A. C. M. Coxon.
B.Ch.—J. W. Stretton, C. B. Clarke.

The following candidates have been approved at the examinations indicated:

THIRD M.B., B.Ch.—*Part I, Surgery and Midwifery*: C. G. Ainsworth, A. B. Appleton, C. S. Atkin, A. B. Bratton, W. M. Casper, M. T. Clegg, B. K. T. Collins, S. J. Cowell, F. C. Cozens, E. J. Crisp, E. C. Curwen, H. B. Dodwell, E. A. Fiddian, L. P. Garrod, H. L. Garson, W. N. Goldschmidt, E. H. H. Granger, C. Griffith-Jones, J. C. N. Harris, G. A. Harrison, F. B. Hobbs, L. W. Jones, E. I. Lloyd, W. H. Palmer, H. A. A. Pargeter, F. P. N. Parsons, P. W. Putnam, R. S. Scott, T. H. Somerville, E. D. Spackman, G. D. C. Tracy, A. B. Walker, T. T. B. Watson, A. D. Whitelaw, V. Wilkinson, M. Wong, F. G. Wood, W. G. Woolrich, H. B. Yates, K. J. Yeoc.

Part II, Medicine, Pathology, and Pharmacology: C. G. Ainsworth, F. Allen, J. C. Andrews, C. S. Atkin, S. H. Barnett, D. C. Beaumont, A. C. Beney, P. F. Bishop, C. N. Carter, P. D. H. Chapman, A. O. Curtis, S. J. Cowell, L. Cunningham, H. B. Dodwell, W. D. Doherty, H. V. Edwards, L. S. Gathergood, A. C. V. Gosset, E. H. H. Granger, J. R. Harris, G. A. Harrison, F. B. Hobbs, L. W. Jones, J. M. Lawrie, P. Lazarus-Barlow, F. S. Maclean, J. W. McK. Nicholl, E. S. Orme, R. Y. Paton, C. J. Penny, K. Playfair, J. L. Potts, W. B. Purchase, G. P. N. Richardson, A. G. Shurlock, F. N. Sidebotham, J. A. B. Spell, F. V. Squires, W. S. Sykes, D. C. L. Vey, H. N. Webber, A. T. Westlake, A. D. Whitelaw, J. Whittingdale, V. Wilkinson, F. B. Winfield, W. G. Woolrich.

DIPLOMA IN MEDICAL RADIOLOGY AND ELECTROLOGY.—*Part I, Physics and Electrotechnics*: W. Bell, T. I. Candy, W. H. Coldwell, T. J. A. Connolly, H. T. Cubbon, J. P. S. Dunn, A. H. Gregson, R. N. Gutbrie, J. B. Higgins, M. H. Knobb, R. S. Paterson, J. A. Wilson. *Part II, Radiology and Electrology*: W. Bell, J. P. Bracken, T. I. Candy, W. H. Coldwell, T. J. A. Connolly, H. T. Cubbon, A. H. Gregson, R. N. Gutbrie, J. B. Higgins, R. S. Paterson, F. G. Rose.

On the recommendation of the Committee on Medical Radiology and Electrology, the diploma in Medical Radiology and Electrology has been granted to Sir A. D. Reid, K.B.E., C.M.G., R. W. A. Salmoud, O.B.E., H. Martin Berry, J. F. Hall-Edwards, J. T. Case, M.D.

UNIVERSITY OF LONDON.

The following candidates have been approved at the examinations indicated:

M.D.—*Branch I (Medicine)*: M. Bararov, S. Batchelor, W. M. Feldman, E. E. Herga, K. R. Hill, G. C. Linder, R. J. Perkins, E. D. Scott, J. A. Tomes. *Branch II (Midwifery and Diseases of Women)*: H. W. Evans, Violet I. Russell. *Branch III (State Medicine)*: M. Radford. *Branch IV (Tropical Medicine)*: G. A. S. Madewick, E. S. Phipson (University Medal).
M.S.—*Branch I (Surgery)*: H. E. Griffiths, R. L. Horton (University Medal), S. W. M. Jones, S. L. M. Reader, C. S. L. Roberts, H. J. D. Snythe, D. G. C. Tasker.

UNIVERSITY OF MANCHESTER.

The following candidates have been approved at the examinations indicated:

THIRD M.B., CH.B.—*General Pathology and Morbid Anatomy*: R. S. van Aalten, P. D. Abbott, R. Anderton, J. H. Appleton, Mary W. Atkinson, J. B. Bennett, Doris H. Bentham, B. Broman, G. H. Buckley, E. W. Clough, H. M. Coope, Margaret Derbyshire, O. M. Duthie, Kathleen M. Eastwood, Beatrice L. Ellison, H. E. Emmett, H. P. Fay, J. H. Fletcher, W. Geraghty, Doris M. Hardman, A. Ingham, E. L. Jones, J. I. Kelly, Nora Mills, Winifred H. Mitchell, Louis Morgenstern, A. C. Newman, Hilda Pratt, G. T. Robinson, A. Rosenstone, F. H. Scotson, H. Southworth, G. B. Stephouse, L. Unsworth, Emmeline Wade, Margaret J. Warburton, Margaret Wild, J. Worthington, J. Yates. *Pharmacology and Therapeutics*: Margaret Derbyshire, Gwendolen A. G. Edwardes-Evans, R. Handley, G. A. Lord, L. Morgenstern, Margaret J. Warburton. *Hygiene*: L. Boyars, R. Handley, L. W. Kay, G. B. Lord, L. Morgenstern. *Forensic Medicine*: R. J. Allison, Caroline M. Edwardes-Evans, C. Nelson, H. D. Preston, S. J. Woodall.

* Awarded distinction in Pathology.

† Awarded distinction in Pharmacology.

FINAL M.B., CH.B.—F. H. Anderson, May Blakiston, Phyllis M. Congdon, J. W. Crawshaw, A. M. El Aguizy, Florence M. L. Graham, E. M. Greaves, A. Haworth, G. E. Hayward, Irma M. C. Jehansart, A. W. Kirkham, J. Leather, G. H. Lees, Gertrude B. Leigh, §P. B. Mumford, T. O'Brien, Florence G. Sberry, Doris A. Taylor, H. Tomlinson, R. Williamson. *Medicine*: Martha F. Barritt, Violet M. Jewson. *Obstetrics*: T. E. Coope.

‡ Awarded second-class honours.

§ Awarded distinction in Obstetrics and Surgery.

The Services.

HONOURS.

THE following appointments to the Order of the British Empire are announced:

C.B.E. (*Civil Division*): Surgeon-Commander Thomas William Myles, R.N. O.B.E. (*Civil Division*): Surgeon-Lieutenant James Dorrington Bangay, R.N.

Medico-Legal.

SUICIDE AND THE WORKMEN'S COMPENSATION ACT.

IN a case which was heard recently at Greenwich County Court a claim for compensation was made by a woman whose husband was killed on a railway. The defence was that he had committed suicide by throwing himself in front of a train which was coming into the station. The engine driver gave positive evidence to the effect that he had seen the deceased deliberately take two steps towards the edge of the platform and then deliberately throw himself in front of the engine when it was a few yards away. In the light of this testimony—there being no evidence on the other side as to how the man came to be on the rails—the judge said he was bound to hold that death was not caused by accident arising out of and in the course of the employment, and gave judgement for the employers.

The decision is interesting, because at the inquest which had been held on the deceased the coroner found a verdict of accidental death. It is not to be supposed, however, that the defence of "suicide" will always succeed in answer to a claim under the Act. In another case of recent date the Court of Appeal decided that where a workman commits suicide by reason of insanity resulting from an accident arising out of and in the course of his employment, his dependants are entitled to compensation if the suicide was a result of the accident and not a result of the brooding over the injury received. In that case a medical specialist had expressed the opinion that he was suffering from insanity. In his opinion the accident had given the man a shock, and the shock and suffering had resulted in melancholia, which had been the first stage of insanity. In his view the melancholia, resulting from the accident, left no doubt as to the cause of insanity.

Medical News.

DR. C. OWEN FOWLER, president of the Surrey Branch of the British Medical Association, has been appointed a magistrate for the Borough of Croydon.

DR. A. G. NEWELL of Harringay, a vice-president of the Medico-Political Union and chairman of its Finance Committee and vice-chairman of its Executive Committee, informs us that he has resigned from that Union, owing to his opposition to certain lines of policy.

DR. T. R. LLEWELLYN, on the occasion of his leaving Penygraig, near Pentypridd, to take up an appointment of regional officer under the Ministry of Health, has been presented by his friends with gifts to the value of £400, including a medical dressing case, and a diamond wristlet watch to Mrs. Llewellyn.

AMONG the Friday evening discourses to be given at the Royal Institution of Great Britain, 21, Albemarle Street, W.1, is one on February 4th at 9 p.m., by Professor A. D. Waller, M.D., F.R.S., on the electrical expression of human emotion. The lecture programme includes a course of four lectures to be delivered on February 22nd, March 1st, 8th, and 15th by Professor Arthur Keith, M.D., F.R.S., on Darwin's theory of man's origin in the light of present-day evidence.

DR. THOMAS FAWSITT of Oldham was recently entertained by his medical colleagues at dinner in commemoration of his retirement after fifty years' practice. The function was arranged under the auspices of the Oldham Medical Society.

DR. FRANK HEWKLEY, vice-president of the League of Mercy, has been awarded the Order of Mercy.

DR. JOHN MCGIBBON, lecturer in midwifery and gynaecology in the Edinburgh Extramural School, has been appointed professor of midwifery in the University of Johannesburg, South Africa.

THE annual general meeting of the Medical Officers of Schools Association was held at 2, Savoy Hill, Victoria Embankment, W.C.2, on December 17th, 1920. Mr. R. C. Elmslie was elected president, and thanks were accorded to Dr. James Kerr, the retiring president. It was agreed to continue publication of the journal, *School Hygiene*, and Drs. James Kerr and C. W. Hutt were elected editors.

THE Aldred Lecture before the Royal Society of Arts on Wednesday, January 12th, at 8 p.m., will be given by Dr. C. S. Myers, F.R.S., Director of the Psychological Laboratory, and Lecturer in Experimental Psychology, University of Cambridge. The subject is "Industrial Fatigue."

THE officers of the 29th General Hospital, stationed at Salenica during the war, held their second annual Reunion dinner at the Queen's Hotel, Manchester, on December 11th, 1920. Lieut.-Colonel S. H. Withers, C.M.G., R.A.M.C.(R.), presiding. There was a large and enthusiastic company present, including Colonel Sir Wm. Thornburn, K.B.E., C.B., C.M.G., Colonel R. J. Kelly, C.B., Lieut.-Colonel W. Thompson, Lieut.-Colonel H. T. Fairbank, O.B.E., D.S.O., Major J. Arnold Jones, O.B.E., Major A. Corsar Sturrock, Major Wm. Stewart, Major Webster and Captain A. Percy Groves.

ON the occasion of his eighty-fourth birthday Dr. W. W. Keen will be entertained at dinner and presented with his bust by a number of medical, scientific, and civic organizations, and by friends in Philadelphia and other cities.

As will be seen by an advertisement elsewhere, the Indian Government is inviting applications for two Tata professorships at the School and Hospital of Tropical Medicine about to be established in Bombay. The selection of the candidates for the two chairs—the first in clinical medicine and therapy, and the second in protozoology—has been placed by the Indian Government in the hands of the Tropical Diseases Committee of the Royal Society. The appointments are whole-time, and are made in the first instance for five years, but may be extended by the Indian Government, on the recommendation of the governing body of the school. A condition with regard to salary is rather unusual; the offer is of 1,500 to 1,000 rupees a month, according to the scientific standing of the candidate. There is no pension. If the appointment is renewed the incumbent will be entitled to furlough for six months out of India on full pay, and so thereafter for each period of five years. The incumbent may also be able to obtain study leave on furlough pay for six months out of India.

A THREE months' course of lectures and demonstrations in hospital administration for the diploma in public health will be given by Dr. R. M. Bruce, medical superintendent, at the Western Hospital, Seagrave Road, Fulham, on Tuesdays and Fridays, at 5 p.m., beginning on Tuesday, January 4th. The fee for the course is £3 3s., and payment should be made beforehand to the Metropolitan Asylums Board.

ON Saturday, December 11th, 1920, in the Hotel Majestic, the annual oration of the Harrogate Medical Society was delivered by Sir Berkeley Moynihan, K.C.M.G., C.B., on the subject of gastric ulcer. Many illustrative lantern slides of radiographs were shown, some of which were unique. The President, Mr. Herbert Frankling, C.B.E., and over 80 members of the Society and other guests, including members of the nursing profession, were present.

DR. R. L. GUTHRIE, O.B.E., has been appointed His Majesty's coroner for the Eastern District of the County of London.

LAST summer a request was received from the Council of the National Institute for the Blind for permission to publish in Braille, for the use of blind students of massage, certain articles appearing in the BRITISH MEDICAL JOURNAL. In making the application, which was readily granted, the aim of the Council of the Institute was to help its students to have as far as possible the same opportunities as sighted persons for keeping in touch with subjects likely to be of benefit to them in their work as masseurs. Mr. J. Lloyd Johnstone, M.R.C.S., librarian of the Institute, now informs us that some half-dozen papers have been reproduced in Braille and are kept for use in the library of the institute. Among these are Dr. Wilfred Harris's lecture on chronic paroxysmal trigeminal neuralgia, Dr. R. G. Abercrombie's note on physiopathic paralysis of the hand, and Dr. Charles Mackay's paper on the place of muscle re-education in the treatment of anterior poliomyelitis.

Letters, Notes, and Answers.

As, owing to printing difficulties, the JOURNAL must be sent to press earlier than hitherto, it is essential that communications intended for the current issue should be received by the first post on Tuesday, and lengthy documents on Monday.

ORIGINAL ARTICLES and LETTERS forwarded for publication are understood to be offered to the BRITISH MEDICAL JOURNAL alone unless the contrary be stated.

CORRESPONDENTS who wish notice to be taken of their communications should authenticate them with their names—of course not necessarily for publication.

AUTHORS desiring reprints of their articles published in the BRITISH MEDICAL JOURNAL are requested to communicate with the Office, 429, Strand, W.C.2, on receipt of proof.

In order to avoid delay, it is particularly requested that ALL letters on the editorial business of the JOURNAL be addressed to the Editor at the Office of the JOURNAL.

THE postal address of the BRITISH MEDICAL ASSOCIATION and BRITISH MEDICAL JOURNAL is 429, Strand, London, W.C.2. The telegraphic addresses are:

1. EDITOR of the BRITISH MEDICAL JOURNAL, *Aitiology*, Westrand, London; telephone, 2630, Gerrard.
2. FINANCIAL SECRETARY AND BUSINESS MANAGER (Advertisements, etc.), *Articulate*, Westrand, London; telephone, 2630, Gerrard.
3. MEDICAL SECRETARY, *Medisecra*, Westrand, London; telephone, 2630, Gerrard. The address of the Irish Office of the British Medical Association is 16, South Frederick Street, Dublin (telegrams: *Bacillus*, Dublin; telephone, 4757, Dublin), and of the Scottish Office, 6, Rutland Square, Edinburgh (telegrams: *Associate*, Edinburgh; telephone, 4361, Central).

QUERIES AND ANSWERS.

HIGH MYOPIA.

"OCULUS" has a case of a boy, aged 10½ years, with a large patch of old choroidal atrophy in the macular region of the right eye and myopia of 10 D in the left. Visual acuity amounts to R. $\frac{2}{60}$ not improved by glasses, and to L. $\frac{2}{60}$ improved to $\frac{3}{60}$ by -10 D sph. The myopia in the left eye is evidently increasing. In view of the risk of increase of myopia, separation of the retina, etc., in the left eye, how is the boy's education to be continued? Would such a case be received into a school for the blind, or are there any special schools for myopes to which he could be sent? "Oculus" asks for information with regard to schools or classes for myopes suitable for such a case.

The youth of this child, the serious defect of the eyes—amounting to loss of the central vision of the right and poor vision in the left—make it dangerous for education to be carried on at an ordinary school. There are many classes for

children with high myopia now established in connexion with the elementary school system, and working after the model inaugurated in London. This scheme of education can be secured in some public schools by favour of the head masters. Mr. Bishop Harman, who has oversight of the London blind schools and myope classes, informs us that this boy would not be admitted to a myope class, but entered for a blind school. His vision would be too bad to do the work of the myope class, and the grave risk of further deterioration of vision makes it necessary that the boy should learn Braille at a time when he can do it with the greatest ease; so that, should the worst be realized, he would have command of the recognized means of communication amongst the blind, and of a full literature.

INTELLIGENCE TEST.

"J. A. M."—We understand that the most satisfactory apparatus for carrying out tests for mental deficiency is the test material for the measurement of intelligence devised by Mr. Ferman, Professor of Education, Leland Stanford Junior University. The material can be obtained from Messrs. H. K. Lewis and Co., Ltd., 136, Gower Street, W.C.1, price 3s. 6d. net.

INCOME TAX.

"A. H. G." inquires if the cost of a six months' post-graduate course in radiology can be treated as a professional expense in calculating the profits of his general practice including radiology.

* * We think not. The expense seems to represent outlay in improving his mental equipment, and is analogous to the expense of purchasing additional machinery or instrument.

"T. N. C." inquires whether the cost of replacement of a motor car is to be measured according to the original cost of the car displaced as a maximum.

We have dealt with this point before, and can only say here that the official evidence put before the Royal Commission by the Board of Inland Revenue justifies, in our opinion, a claim to the full cost of the replacement, provided that the car purchased does not cost more than the old car would have done in present circumstances.

"H. E. B." inquires as to the inclusion of certain income in the Schedule D return.

* * He can include the "regular salary as district medical officer" but not, as we think, the "pension for disturbance out of former office under the guardians"; in the latter case no expenses are chargeable against the income and there seems to be no reason, therefore, for departing from the strict legal procedure.

"A. M." asks if a medical practitioner can deduct (a) £500 spent in purchasing a "panel," and (b) the cost of purchasing a small car.

No; in both cases the cost represents an outlay of capital sunk by our correspondent in the purchase of a practice and equipment. The cost of replacing the car will normally be deductible as an expense of maintenance.

LETTERS, NOTES, ETC.

TREATMENT OF ERYSIPELAS.

DR. E. T. LARKAM (Birmingham) writes: Amongst the many fairly recent suggestions for the treatment of cutaneous erysipelas an old effective method by means of the local application of the strong solution of perchloride of iron (liq. ferri perchlor. fortis) has not, to my knowledge, been mentioned. In 1895, when a house-surgeon, I had to treat a virulent case following amputation of a toe; in four days the erysipelas had spread just above the knee, in spite of the application of ichthyol, painting a broad band of liquor iodi fortis above the upper limit of the disease, and the internal administration of large doses of tincture of perchloride of iron. I thoroughly painted the limb with the strong iron solution, continuing the painting two inches above the upper limit of the disease on healthy skin; at the same time I applied lint soaked in the iron solution and covered the limb with cotton-wool. This dressing was carried out twice daily. The erysipelas spread but slowly during the next forty-eight hours, and in three days became totally arrested. I have had many such cases since, including the so-called idiopathic facial variety, and have invariably used this remedy, with unflinching success.

POSTURE IN DEFAECATION.

"R. B. G." writes, with reference to Dr. D. de V. Hugo's communication (December 11th, 1920, p. 923, that he remembers an address given by Professor Chiene on "Movement in Life," wherein he emphasized the benefit of what he called the "caddy-hunker" position in defaecation as witnessed by him on the wayside in South Africa, with resulting large well-formed stools, as compared with the broken-up and

ill-formed faeces of those who adopted the ordinary sitting posture on the modern closet. His advice was "defaecate slowly" and "micturate slowly."

We are glad to say that Dr. Hugo was in error and that Emeritus Professor John Chiene, C.B., is still happily living in retirement in the Midlothians.

A TEAPOT STIRRER.

DR. LACHLAN GRANT (Ballachulish) has designed a simple means for obtaining a better and quicker infusion of tea in an ordinary teapot. This consists of an attachment of aluminium fixed to the inside of the cover of the teapot. By turning the knob of the lid the contents are agitated and the infusion is hastened. Thus the lid need not be lifted in order to stir up the contents with a spoon, nor need the teapot be waved about as some old-fashioned ladies used to do. The "stirrer" can be attached to teapots made of earthenware, porcelain, or metal. Teapots so fitted are, we understand, manufactured by Messrs. Gibson and Sons, Limited, Albany Potteries, Burslem, Stoke-on-Trent.

RABIES IN SOUTHERN INDIA.

The annual report of the Director of the Pasteur Institute of Southern India, Coonoor, shows a further increase of 347 in the number of patients annually undergoing treatment for rabies; land has been purchased for the erection of two new lines of quarters—one for indigent and one for paying patients. In the year ending February 29th, 1920, six patients died from hydrophobia during the course of treatment; eight died less than fifteen days after the completion of treatment, and twenty-four more than fifteen days after the completion of treatment. The last are classed as failures, giving a rate of 0.75 per cent. The patients comprised 3,000 Asiatics, 100 Europeans, and 75 Eurasians.

THE DECLINE OF LATINITY IN FRANCE.

WE can only speculate as to the psychological reason that led the French to frenchify scientific terminology, more particularly in anatomy and pathology. Molière, it is true, brought medical dog latin into disrepute by his satire in *Le médecin malgré lui*, but the change into the vernacular took place so long after Molière poked fun at the mediæval practitioner that they do not seem to stand in the relation of cause and effect. The explanation would no doubt be that it is much simpler to deal with French names than Latin, but it may be doubted whether the change is really of the nature of a simplification. It seems simpler to speak of the pudic nerve than the shameful nerve, the gluteal muscles than the buttock muscles (*muscles jessiers*). The practice of naming operations and diseases after their supposed inventors is carried to an extreme in France, and such inventors are invariably, or almost invariably, French. The only exceptions we can recall are Bright's disease, Addison's disease, and, occasionally, Barlow's disease, but for the last name I there is a Frenchman who has a revisionary interest. So far as we are aware, no other country has pushed Chauvinism to this degree in matters scientific, and we venture to hope that Latin will preserve its ascendancy. Owing to differences of pronunciation—in which we English are the greatest sinners—even Latin ceases to be a uniform spoken language, but it is universally understood when written. Be it remarked, however, that in France Latin is no longer compulsory, so that some present-day students, medical and pharmaceutical, are unable to tackle even a simple prescription in that classical language.

CORRECTION.

THE name of Mr. G. E. Elkington was incorrectly printed in the list of successful candidates for the diploma of F.R.C.S. Eng., published in our issue of December 18th, p. 956.

VACANCIES.

NOTIFICATIONS of offices vacant in universities, medical colleges, and of vacant resident and other appointments at hospitals, will be found at pages 29, 30, 32, 33, and 34 of our advertisement columns, and advertisements as to partnerships, assistantships, and locum tenencies at pages 31 and 32.

SCALE OF CHARGES FOR ADVERTISEMENTS IN THE BRITISH MEDICAL JOURNAL.

	£	s.	d.
Six lines and under	0	9	0
Each additional line	0	1	6
Whole single column (three columns to page) ...	7	10	0
Half single column	3	15	0
Half page	10	0	0
Whole page	20	0	0

An average line contains six words.

All remittances by Post Office Orders must be made payable to the British Medical Association at the General Post Office, London. No responsibility will be accepted for any such remittance not so safeguarded.

Advertisements should be delivered, addressed to the Manager, 429, Strand, London, not later than the first post on Tuesday morning preceding publication, and, if not paid for at the time, should be accompanied by a reference.

NOTE.—It is against the rules of the Post Office to receive post-*estante* letters addressed either in initials or numbers.

A British Medical Association Lecture ON THE LINES OF ADVANCE IN THE SURGERY OF BREAST CANCER.

DELIVERED BEFORE THE SHEFFIELD BRANCH ON
OCTOBER 29TH, 1920.

BY

W. SAMPSON HANDLEY, M.S., F.R.C.S.,

SENIOR TO THE MIDDLESEX HOSPITAL AND ITS CANCER CHARITY;
HUNTERIAN PROFESSOR, ROYAL COLLEGE OF SURGEONS
OF ENGLAND.

FOR many years after the operation for breast cancer had passed from the primitive stage of "cutting out the lump," its development proceeded by a method of "trial and error." A surgeon by clinical observations of his failures extended the scope of his operation in this or that direction. He then devoted himself to the collection of statistics showing the result of his particular method of operation. It was hoped by a statistical comparison of the results of different operations to arrive at the "best" operation.

There can be no doubt that very considerable advances were in this way realized by American surgeons, culminating in the Halstead operation, which for some years represented the best means for the surgical eradication of breast cancer.

It will be seen that this method largely eliminates the pathologist from the scheme of things. The surgeon "guesses" his method, aided only by clinical observation, and tries it out in comparison with the guesses of other surgeons. In the comparison, statistics necessarily play a dominant part. Now the essential vice of statistics, from which even Professor Karl Pearson has been unable to redeem them, is that they assume the homogeneity of a collection of unlike things. Even granting, however, that statistics will give an accurate idea of the value of a certain operation, it has to be remembered that the possible variations of operative method are infinite in number. They can never all be tried out. Cumbersome and slow in operation, the statistical method leads firmly to an inconclusive result. As Claude Bernard long ago pointed out, statistics are not a weapon of primary importance in the search for truth, though they may supply useful secondary or confirmatory evidence.

Let me illustrate my meaning by a comparison. There are an infinity of possible routes from London to Leicester. To ascertain the best line for a railway between these two places one would not proceed by a comparison of the routes advised by different travellers with statistics of their relative times. The construction of the railway would be preceded and determined by a systematic survey of the country. It may be fairly claimed that in the application of an analogous scientific procedure to the operative treatment of breast cancer this country has led the way. The special need was detailed knowledge of the mode of spread of the disease, only to be obtained by the microscope.

Sir Harold Stiles, the pioneer who first addressed himself to this task, detected cancerous lymphatics widely diffused throughout the breast, which, moreover, he showed to be a much more extensive organ than it had been generally considered. He drew special attention to the necessity of wide removal of the pectoral fascia, while deprecating the removal of an unnecessary amount of skin. In these respects the operation suggested by him and practised by Watson Cheyne from 1892 onwards was much superior to that of Halstead. Subsequent work has required only minor modifications in it.

Stiles was prevented from reaching a general conception of the mode of spread of cancer by the defects of his material, which consisted only of excised breasts. Working on *post-mortem* subjects at the Middlesex Hospital for several years from 1903 onwards I demonstrated the centrifugal spread of breast cancer in the fascial lymphatic plexus, and detected its microscopic growing edge in this plexus at points far removed from the breast—for example, in the deltoid region, or the upper abdominal wall. The only framework which fits the observed facts is the now generally accepted permeation theory, which has replaced the embolic theory of dissemination.

A criterion is thus provided for judging any suggested operation for breast cancer, and the surgery of the disease is placed upon a complete rational basis. Technical variations in the operation, of which many are possible, must conform to the following conditions:

1. The primary growth, from which centrifugal spread begins, must always be the centre of the operation area. Thus an operation for a growth of the inner edge of the breast is not the same as an operation for a growth of the outer edge.
2. A circular area of skin 4 or 5 in. in diameter and centred upon the primary growth requires removal.

Here I may digress a moment to explain that the opinion long held, that cancer spreads along the skin, is shown by pathology to be erroneous. The apparent spread of cancer along the skin is really a punctate spread to the skin at various isolated points from the infected subjacent fascial lymphatic plexus. Since this process is secondary to and later than the spread of permeation in the fascial plexus, it follows that the area of skin infected is small compared with the area of permeation in the deep fascia. The ablation of a very large area of skin is thus shown to be unnecessary, the removal of a large area of fascia essential. I submit, with all respect to Professor Halstead, for whose work and character I have a great admiration, that in these two respects the Halstead operation erred by excess and by defect. For while he removed a large area of skin, Professor Halstead did not fashion skin flaps by undermining so as to ablate a larger area of deep fascia.

3. A circular area of deep fascia 10 or 12 inches in diameter and centred upon the primary growth must be ablated. It is first exposed by raising thin flaps of skin and subcutaneous fat, then surrounded by a ring incision, then elevated all round its edge from the deep parts until the line is reached where muscle also must be removed. The removal of a maximal area of deep fascia is demanded by the presence in this layer of the growing edge of the disease.

4. The removal of deep fascia is often too limited in the epigastric region. I have shown that this region is specially dangerous because here only a layer of fibrous tissue separates the fascial plexus from the subperitoneal fat. It is here that by direct infiltration growth often reaches the peritoneal cavity. In all cases, except perhaps with a growth of the upper edge of the breast, an area of the anterior layer of the sheath of the rectus abdominis requires removal.

Recently I was asked to see a middle-aged lady who, four months after a blow on the breast, was operated on for cancer of the breast. Thirteen months later some small nodules were detected at the lower end of the operation scar. They were excised and x-ray treatment was begun. Fourteen months after the second operation she began to suffer from dyspepsia, with pain in the left epigastric region, culminating a fortnight later in vomiting like a bilious attack. These, I may remark, are the symptoms which characterize some of the cases of invasion of the abdomen at the epigastric angle. On examination I found a recurrent nodule, near the scar of the secondary operation in the epigastric region. The left lobe of the liver was palpable and irregularly indurated. It had become infected by contact with the cancerous epigastric peritoneum. There was no other definite evidence of secondary deposits. I believe, therefore, that had the anterior layer of the rectus sheath in the epigastric region been more widely removed, this lady might still be free of her disease.

Recurrence in the Subclavian Glands.

These glands, I may remind you, more correctly named than the subclavian artery with which they have no relation, lie at the apex of the axilla, below the clavicle, between the subclavius muscle and the upper edge of the pectoralis minor. In front they touch the costocoracoid membrane which separates them from the great pectoral muscle. On their outer side lies the axillary vein. They may be found infected in breast cancer when the lower axillary glands are still free from disease. This is due to the occasional existence of a lymphatic trunk which passes from the mammary region directly to them through the substance of the great pectoral muscle.

Recurrence in the subclavian glands presents itself in the form of a deep lump situated below the middle of the clavicle, and sometimes apparently adherent to this bone. This form of recurrence is frequent in the practice of surgeons who have not seen the necessity of clearing the axilla up to its extreme apex. In one week recently

I met with two cases of the kind. It is a form of recurrence which can be prevented with almost absolute certainty by careful axillary dissection, and the surgeon who slurs over this part of the operation incurs a heavy responsibility.

Obviously Inadequate Operations.

It is still not uncommon to see cases in which only a portion of the breast has been removed for cancer or in which the axillary dissection has been omitted. Rarely a week passes without a case of this kind coming under observation at my cancer out-patient clinic at the Middlesex Hospital. In some of these cases the lump has been considered innocent and the operator has failed to have it examined. The routine pathological examination of every supposed innocent tumour removed from the breast should never be omitted. Other cases have been in the hands of inexpert or occasional surgeons, who do not realize that the removal of a breast cancer is much more difficult than an appendectomy or the radical cure of a hernia. I venture to suggest that the operation for breast cancer should be left entirely in the hands of hospital surgeons, and that every surgeon who undertakes it should previously study the mode of spread of the disease.

OPERATION RESULTS.

Believing as I do that operation in breast cancer is worth doing to avert the distresses of external ulceration, even though the disease subsequently returns in the internal organs, and believing also that the interests of the individual case in this matter should outweigh the desire of the surgeon for a favourable statistical record, I have not refused operation in any case where I thought I could prolong the patient's life or make her end more comfortable.

Consequently I have no startlingly favourable results to record. Forty-eight per cent. of my cases which could be traced have remained free from recurrence for three years, as compared with 44 per cent. of Judd's and 47 per cent. of Halstead's cases. I may remark that in America cases come to operation earlier than in this country, as shown by the comparatively large percentage of cases without axillary gland enlargement in Halstead's statistics. I estimate that 90 per cent. of the cases of carcinoma which I see already have enlarged axillary glands.

It is when we come to consider the sites of the recurrence that the results become really interesting. A new type of recurrence, to which I have given the name intercostal recurrence, becomes a principal feature of the picture. Associated with this or separate from it, and even more frequently, recurrence in the supraclavicular glands is seen.

The local recurrences in and about the scar, usually multiple, which used to be found in 35 to 50 per cent. of cases of recurrence, have become rare. I confidently appeal for confirmation of this statement to any surgeon present who operates on the lines laid down by the permeation theory of dissemination. Cutaneous recurrences have been reduced to a very low percentage. In half the cases where they have been seen the usual prophylactic course of x rays, which I always advise, has for one reason or another been neglected. I have not seen any case of isolated axillary recurrence, nor of recurrence in the situation of the subclavian glands, and only one of recurrence in the remaining clavicular portion of the pectoral muscle. In some cases intrathoracic recurrence or return of the disease in the liver has taken place. In one case the first sign of return was in the femur on the side of the growth.

In a group of 26 cases of recurrence taken from my private notebooks, and including cases of palliative operation, the disease reappeared in the following situations:

Locally (two of these cases had escaped a proper x-ray course)	4
Supraclavicular	9
Intercostal	5
Peripheral fascial recurrence	2
Cerebral	1
Thoracic	4
Abdominal	1

Thus the majority of recurrences belong to what may be called (a) the supraclavicular, (b) the intercostal types. No case of diffuse flap recurrence—the type formerly so common—is noted.

Intercostal Recurrence.

The second common variety of recurrence—intercostal recurrence—is frequent in my experience. I am not acquainted with any precise description of this mode of return.

The first sign of it is the appearance at the inner ends of one or more of the first, second, or third intercostal spaces of small nodules, adherent to the intercostal muscles but not adherent at first to the skin. These nodules are probably an index of retrosternal deposits originating in the anterior mediastinal glands. Later on other similar nodules, also adherent to the intercostal muscles or to the ribs, appear along the first, second, third, fourth, and fifth intercostal spaces as far back as the mid-axillary line. The nodules, as they increase in size, become adherent to the skin and may ulcerate. They are distinguished from cutaneous recurrences by the fact that in their early stages the skin glides freely over them. It is obvious that they indicate lymphatic infection of the intercostal spaces, or of the anterior mediastinal glands, already present at the time of the original operation.

The interpretation of these results seems to be clear enough. The infrequency of local recurrence justifies the pathological principles of the operation. The recurrences take place beyond the range of the operation either in the anterior mediastinal or in the supraclavicular glands, less often in the viscera. It seems reasonable to infer that at the time of the original operation microscopic advance parties of carcinoma cells had already reached these glands.

We must therefore get our cases earlier, and we must devise some means of dealing with supraclavicular and intercostal recurrences either by way of prophylaxis at the time of the first operation, or by way of cure when these concealed dépôts first manifest themselves clinically.

I do not propose to deal to-night with the important matter of the education of the public in the recognition of the early signs of cancer. It would be easy to do too much in this direction and to disturb that sense of practical immortality which is one of the blessings of health in most normal individuals. We do not want to produce an epidemic of cancerphobia. What the public should know might be summed up in a few brief sentences:

After the age of 40 every individual is increasingly liable to cancer. Cancer is insidious in its onset and painless in its early stages. If taken in time, cancer may be cured by operation. If you are over 40, always get a doctor to examine you if you notice a lump or any departure from your normal state of health.

One of the principal obstacles to progress is the belief of the public that cancer cannot exist without pain. Medical men should miss no opportunity of correcting this mistake.

POSSIBLE EXTENSIONS OF THE PRIMARY OPERATION.

It would be quite possible to extend the scope of the original operation so as to include the routine exploration of the anterior mediastinum, and I have done this in six cases, all of which recovered. In only two of these did I find infected glands. In one of these two cases the growth, apparently an early one, was situated near the sternal margin of the breast. Widespread internal recurrence in the thorax took place within six months. In the other case, operated upon more than a year ago and at present free from recurrence, the glands showed irritative hyperplasia and contained a few small groups of epithelial cells.

It would thus appear that anterior mediastinal infection is present at the time of operation only in one case in three. When it is present, operative removal of the glands may fail to anticipate dissemination. For these reasons and because it increases the length and severity of the operation, I have abandoned exploration of the anterior mediastinum. Similar arguments lead me to reject the idea of routine removal of the supraclavicular glands.

Supraclavicular Recurrence.

Recurrence in the posterior triangle first manifests itself in the glands lying immediately above the clavicle and below the posterior belly of the omohyoid muscle. In examining the triangle special attention must be given to the angle between the clavicle and the posterior edge of the sterno-mastoid. Here on deep pressure an enlarged gland is often found lying in close contact with the subclavian artery. Infection of the supraclavicular glands takes place along the efferent lymphatics from the glands at the apex of the axilla, from the subclavian glands, and

sometimes from the anterior mediastinal glands. The subclavian group of glands might with advantage be renamed the infraclavicular glands. They lie, of course, behind the costo-coracoid membrane. When the supraclavicular glands are once infected, extension by permeation may take place along any of the trunks—afferent or efferent—connected with them.

According to Poirier and Charpy their lymph-vascular connexions may thus be classified:

Afferent Vessels.—1 From the posterior part of the scalp, and the skin and muscles of the nuchal region; 2 from the skin of the pectoral region, or even from the mammary integument; 3 lymphatics accompanying the cephalic vein, which slip over the infraclavicular glands in which they should normally terminate; 4 from the axillary glands, especially from the humeral chain; 5 from the cervical portions of the larynx, trachea, and oesophagus; 6 from the pretracheal glands of the neck; 7 aberrant vessels of the internal mammary chain which normally discharge into the great veins; 8 occasionally from the chain of glands lying along the external jugular vein; 9 from the small glands lying in the thorax which accompany the recurrent laryngeal nerves.

Efferent Vessels.—These unite with the efferents of the sterno-mastoid glands to form a common trunk, the jugular trunk which joins the confluence of the internal jugular and subclavian veins.

It will be seen from the foregoing account that cancer cells which have reached the supraclavicular glands have attained a favourable strategic position for the extension of their attack on the body in various directions. They frequently penetrate to the external jugular and the occipital glands, and the union of the efferent trunks from the supraclavicular and the sterno-mastoid glands affords opportunities for the invasion of the latter set of glands which lie along and external to the internal jugular vein. Supraclavicular infection thus is the precursor of wide infection of the neck, and even of the cranial cavity.

In regard to the thorax the position is less unfavourable. It seems doubtful whether any direct vascular connexion exists between the pretracheal glands of the thorax and the supraclavicular glands. In many cases the pretracheal efferent trunks discharge directly into the great veins, and the avenue of permeation into them is thus cut off. It would seem that the only constant lymph-vascular connexion of the supraclavicular glands with the thorax is by way of the efferents of the small recurrent laryngeal chain of glands. This conclusion is an important one, for it justifies the hope that, as experience has now shown, a vigorous attack on enlarged supraclavicular glands may anticipate and prevent invasion of the thorax. If, however, periglandular infiltration with fixation of the enlarged glands has taken place, it is likely that infiltration of the dome of the closely adjacent pleura has occurred, and in such cases operation is useless.

The definite break in the continuity of the permeation channels imposed by the separate termination in the great veins of the lymphatics of the neck and of the thorax respectively is, as we have seen, a great encouragement to the surgeon who contemplates an attack upon supraclavicular glands. The complexity and extent of their lymph-vascular connexions in the neck is a factor which at first sight seems very unfavourable to operation. But all the glands in the posterior triangle are within operative reach, and so, too, are the deep or internal jugular glands. Acting on the advice of the late Sir Henry Butler, I have for some years made it a rule in cases of infected supraclavicular glands to perform a complete lymphatic dissection of the posterior triangle, including also the internal jugular glands. The glands are removed in one piece still embedded in the connective tissue, and therefore with all their lymph-vascular connexions intact.

Treatment of Supraclavicular Recurrence.

There can be no doubt that the right treatment of supraclavicular recurrence in its earlier stages is operative. The operation must, however, be a very thorough and systematic one. On the other hand, it is futile to attempt the operative treatment of late cases of supraclavicular recurrence, where the growth has infiltrated the gland capsule and has passed into the surrounding tissues.

Broadly speaking, if the glands are mobile they should be operated upon; if they are fixed they should be left alone. But if the only fixed gland is situated at the lower and inner angle of the posterior triangle it is sometimes worth while attempting to enucleate it, and if the attempt is successful and a tube of radium is introduced into the

bed from which it came, a long period of freedom from recurrence may be secured, provided at the same time all the glands in the posterior triangle are removed.

The use of radium in the operation would should never be omitted in any operation for supraclavicular glands. It minimizes the great risk of these operations, namely, that of general implantation of carcinoma cells on the raw surface and the subsequent development of a general boardlike carcinomatous infiltration of the field of operation—an unfortunate result which may follow operation in too late a stage.

The boundary line between the operable and inoperable cases, though broadly fixed by the mobility or fixity of the glands, has been pushed forward definitely by the use of radium tubes in the operation wound. In doubtful cases the decision should now be for operation, instead of, as formerly, against it.

It must be borne in mind that subsequent recurrence, say, in the thorax, does not necessarily imply the failure of the operation. Besides its main object, the eradication of the disease, it has an important secondary object—namely, to avert the agonizing brachial neuralgia which is so often seen in the later stages of supraclavicular recurrence. If this object is attained the operation has justified itself, even if the patient dies of some other manifestation of cancer.

The question arises, therefore, whether operation on enlarged supraclavicular glands should be undertaken even in cases where other secondary deposits are known to exist. As a rule this question must be answered in the negative, for in such cases the period of survival is likely to be a short one, and death may occur before pressure on the brachial plexus has had time to develop. It seems better in such cases merely to attempt to delay the development of the supraclavicular deposits by the use of buried radium.

Radiation in the Treatment of Breast Cancer.

In a disease which has such wide-spreading microscopic manifestations as breast cancer, surgical extirpation, though it remains our best resource, is evidently a clumsy weapon. It has for some years been supplemented by post-operative radiation by *x* rays. For the past fifteen years I have uniformly advised post-operative radiation, and my experience shows that cutaneous and subcutaneous recurrence is more likely to occur in cases which have escaped, for one reason or other, this prophylactic course. My practice has been to advise only a short course followed after an interval by a second course.

It is now known with certainty that by an adequate dose of radiation a mass of cancer cells can be killed, and the idea which has hitherto for the most part governed the use of radiation is the destruction of any groups of cancer cells remaining after the operation.

It would of course be preferable, instead of destroying the seed so to alter the soil as to make its growth impossible—in other words, to immunize the patient against his own cancer. For a long time I was sceptical as to this possibility, for whereas in the older parts of a breast cancer degenerate malignant cells enveloped by round cells or by fibrous tissue are normally found in large numbers, at the actual growing edge of the disease there is no round-celled infiltration. Here the healthy active cancer cells have excited no visible reaction and they appear to be accepted as normal denizens of the body. I inferred a close family likeness between the cancer cell and the normal epithelial cell which rendered unlikely the success of attempts to produce immunity against the cancer cell.

It remains a fact that no marked success has attended attempts to induce immunity in an animal against its own spontaneously occurring growth. Nevertheless, the aspect of the problem has lately become more hopeful, largely owing to the work of Professor Russ and his fellow-workers in the Middlesex Hospital Cancer Research Laboratories. Starting with the idea that the tumour substance itself removed, suitably irradiated, and then inoculated might prove to be an immunizing agent, Russ inoculated the irradiated tumour substance. Subsequently in a large percentage of cases the animal is found to be immune to a further inoculation of the active virulent tumour substance, which in a control animal would give rise to a large tumour. These results apply to mouse carcinoma and rat sarcoma.

In addition to his studies of the effect of radiation on tumour cells, Professor Russ is studying the action of radiation upon the response of normal tissues to tumour growth. He finds that if in a number of susceptible rats destined to be inoculated with rat sarcoma some of the animals are previously given repeated very small doses of x rays, this group becomes much less susceptible to the disease. If, however, immunized animals be given large doses of x rays their resistance is broken down and the animals, when reinoculated, bear growing tumours.

It would thus appear that the future of cancer therapy, in the breast and elsewhere, is bound up with a close study of the effects of different varieties of radiation. And since the effects may be harmful or beneficial according to the dose, the radiation must be employed in suitable and accurately measured doses. In using radiation for its destructive effect upon cancerous foci, we must be on our guard against at the same time lowering the general resistance of the body to the disease.

The use of radium in breast cancer has perhaps never, apart from operation, resulted in the cure of the disease, and when it is applied to the surface of the skin the maximum dose which the normal skin will tolerate is too small to deal effectively with any but immediately subcutaneous deposits. When a tube of radium is buried in the connective tissues, and at least half an inch away from the skin, a much larger dose can be given, and a 50 or even 100 mg. tube screened with 1 mm. of platinum can often safely be left *in situ* for twenty-four hours. Under these circumstances, and within a range of one or two inches, the local effectiveness of radium in destroying carcinoma cells greatly exceeds that of the hard x rays which are its chief competitor. On the other hand, with the amounts of radium at present available, it is difficult or impossible to irradiate the whole of the extensive area, a circle ten or twelve inches in radius centred upon the primary growth, within which recurrence may take place. The peculiar advantage of radium when used in the most effective manner—by burying the tube in the tissues—is its intensive action. The peculiar advantage of x rays is their extensive action.

These considerations serve to map out broadly the respective spheres of these two methods of irradiation which can often be used effectively in combination. X rays are specially suitable for prophylactic irradiation covering a wide area, or for the treatment of multiple scattered deposits in the parietes. Radium should be chosen in preference if the recurrence is single or if nodules are only present in one or several limited areas. Radium should certainly be preferred to x rays provided that the affected area is not too large to be dealt with, for I have frequently seen deposits refractory to x rays rapidly disappear under radium.

An effective prophylactic application of radium is after the excision of enlarged supraclavicular glands or the excision of an isolated recurrence wherever situated. A tube of radium is left in the wound, suitably screened, with special care to protect the skin flap from undue action. The risk of implantation recurrence is thus minimized and remaining groups of microscopic cancer cells are exposed to the full force of the radiation.

The beneficial action of radium is not confined to its destructive effect upon carcinoma cells. It appears to have a special anodyne effect, and it sometimes relieves pain in cases of cancer where its effect upon the growth itself is small.

There are striking differences in the vulnerability of carcinomata to radium. Some of them yield rapidly, others are refractory. It should be remembered that some growths have a special tendency to cell degeneration, entirely apart from treatment, while in others most of the malignant cells are vigorous. Thus great variations in vulnerability are to be expected.

It must not be forgotten that small doses of radium stimulate cell activity and mitosis. There is here a distinct danger, for while the cells near the radium tube may be destroyed, more distant ones may assume increased activity. Thus the ideal method of applying radium would be similar to that adopted in the pursuit of big game—namely, to corral the game in a continually narrowing ring of beaters. In other words, if an area can be defined within which the malignant cells are known to be concentrated this area should be attacked by radium from its

periphery towards its centre. It seems to the writer that this principle, though difficult to apply, may prove to be a practically valuable one.

I have never seen evidence in breast carcinoma of any beneficial action of radium on deposits at a distance from the site of application. Such phenomena are occasionally seen in lympho-sarcoma, but I am inclined to think that the action in breast cancer is a purely local one.

With all its limitations radium has secured a definite position in the treatment of breast cancer. It relieves or postpones pain and disability, it prolongs life, and it often substitutes a painless *exitus* from internal recurrence for the distresses associated with ulcerated external recurrences, or the agony of enlarged glands pressing on the brachial plexus. In the case of single recurrences it may presumably complete the cure of the disease.

In favourable cases, and where if necessary the application is repeated, life may be lengthened by three years or more, and the patient enabled to live during this period an almost normal social existence.

The following cases illustrate the use of radium in recurrent breast cancer.

CASE I.—*Carcinoma of Breast; Operation; Recurrence in Supraclavicular Glands; Excision of Glands, Radium Buried in Wound; No Recurrence Eight Years Later.*

In 1912 I was asked by a London surgeon to see his mother, then aged 79, for a carcinoma of the left breast. The growth was removed under nitrous oxide anaesthesia supplemented by ether. I saw her again in December, 1913. She was in excellent general condition and could walk a mile, but in the angle behind the sterno-mastoid and the clavicle on the left side there was a fixed mass, evidently glandular. A further operation was undertaken on December 16th, 1913, and the glands were cleared out of the posterior triangle as high as the spinal accessory nerve. The carotid sheath was opened and the glands within it cleared out. The apparently fixed mass shelled out fairly easily from being the sterno-clavicular joint, leaving a cavity large enough for the insertion of a finger. Higher up were enlarged glands deeply pigmented by carbon, and above these again were the normal glands of the carotid sheath. A tube of radium emanation was left in the cavity for twenty-four hours. At the present time, eight years after the first operation, this old lady remains well and free from recurrence.

CASE II.—*Recurrent Carcinoma; Survival Estimated at a Few Months; Repeated Radium Treatment with Uniform Local Success; Patient still Living an Active Life Two and a Half Years Later; Survival for Nearly Three Years.*

Mrs. O., aged now about 60, was operated upon at the end of 1912 by a well known surgeon in Edinburgh for carcinoma of the left breast, first noticed in the previous May. A guarded prognosis was given. In May, 1917, a small blood cyst formed at the middle of the scar and burst, leaving a deep ulcerated cleft. Dr. Mackenzie of Bath recommended a trial of radium, but the surgeon who had operated discountenanced its use, and gave her but a few months to live. At this juncture, in May, 1917, I first saw the case with Professor A. M. Stalker of Aberdeen. There was at this time a recurrence 1½ in. in diameter fixed to the sternum, with enlarged left supraclavicular glands and an ulcerated nodular thickening of the scar, opposite the seventh rib. Two 50 mg. tubes of radium were inserted beneath the sternal nodule, one of 100 mg. in the left supraclavicular region, and one of 50 mg. in the nodule near the seventh rib. The screen was 1 mm. platinum and the period twenty-four hours. In August, 1917, the patient was feeling and looking well, and the only remaining palpable recurrence was a gland above the left clavicle.

As will appear, the subsequent history of this patient to date (January, 1920) is one of centrifugally spreading recurrences yielding rapidly and completely to further applications of radium. Seven applications in all have been made.

In October, 1917, at Harrogate, a tube of radium was buried above the left clavicle, and one in a new nodular thickening close to the seventh rib. All the winter of 1917 the patient was "most comfortable," and lived an ordinary life as much as possible in the open air. Professor Stalker reported in March, 1918: "There are two or three small glands, less than a pea in size, in the axilla. There is some infiltration in the left supraclavicular region, into which you introduced the radium to begin with. This is the spot which I fear most." Nevertheless, in December, 1918, the patient was "wonderfully well." In March, 1919, Professor Stalker found indications of spread in one or two directions. The ulcer near the seventh rib, though quiescent, never completely healed, and some nodules appeared external to it. In May, 1919, tubes were buried in the right supraclavicular triangle (100 mg.) where a fixed mass of glands had appeared, and the right edge of the sternum, where there was a suspicious thickening, and one in the nodules near the seventh rib. The screen was 1 mm., the time twenty-four hours. This application was followed by severe neuralgic pain down the right arm, which took several months to subside, and left some permanent weakness of the muscles of the hand. The neuralgic pain was probably due to the contraction of a neoplastic mass adherent to the brachial plexus. As before, the treated nodules disappeared within two months of the

irradiation, and even before she left London—that is, three weeks after the application—the supraclavicular lump had shrunk to half its original size, the ulcerated patch had improved considerably, and the sternal thickening could not be felt. A skiagram taken in Bath in 1918 showed suspicious thickening of the root of the left lung, and I was not at all sanguine as to the future. In August, 1919, a small nodule appeared below the right clavicle. In October, 1919, the patient was sleeping wonderfully well, but after a severe cold Dr. Stalker detected some dullness at the left base.

On November 1st, 1919, I saw this patient at her home in Scotland. About three weeks previously she had had a bronchitic attack, with pain at the base of the left pleura, and here a little fluid was present. Her general condition previous to this attack had been so good that she was driving out daily, sometimes in an open vehicle. She was sleeping well and was free from pain. On the left side of the chest—that originally affected—no overt sign of malignant disease remained. In the left supraclavicular triangle and the left axilla no glands could be felt, though above the clavicle large glands had been present prior to the radium treatment. The ulcer, with surrounding nodular deposits, though still open, had partly healed, and was quite flat and innocent as to its base and surroundings. No trace of the original large sternal swelling remained. On the right side, however, though the intercostal deposits in the second and third spaces had disappeared, the disease had made progress under the right breast. Here a large mass was present, with a smaller one in the upper and outer quadrant. The large fixed gland in the lower and inner angle of the posterior triangle—treated six months previously—had disappeared. Over the middle of the right clavicle one small nodule had appeared. The whole right breast was heavy from lymphatic oedema and the nipple swollen. There was some fullness over the lower part of the sternum never noticed before. Radium, 1 mm. screen, for twenty hours was introduced—100, 50, 10, and 10 mg. in various situations beneath the right breast, 10 and 10 mg. at the right edge of the sternum, 10 mg. in the nodule beneath the clavicle.

Though the dullness at the left base was very suspicious, the general condition was excellent, the patient cheerful, and her colour good. The lymphatic oedema of the breast rapidly subsided. In January, 1920, the patient was sufficiently well to travel to Bath and to come down regularly to the family dinner. While at Bath sternal swelling recurred and the right breast became oedematous. A further dose of radium repressed these external manifestations, but signs of rapid pulmonary involvement, with dyspnoea and increasing dullness at the left base, showed that the end was approaching. In April, 1920, she returned to Scotland. Temporary improvement followed, but she died early in May, 1920.

She certainly owes to radium more than two additional years of comfortable and even enjoyable existence, though the treatment was begun when she had been given only a few months to live. X-ray and open-air treatment were used throughout as adjuvants.

CASE III.—Recurrence after Operation for Carcinoma Mammæ: Radium, X-Ray, and Operative Treatment: Three Years Later no Sign of Active Disease.

In September, 1916, I operated on Mrs. D., aged 60, for a rather advanced carcinoma of the upper and outer quadrant of the right breast. A section confirmed the diagnosis. She subsequently had x-ray treatment by Dr. Prowse of Brighton. In March, 1917, she developed a thickening, soon becoming definitely nodular, over the sixth right costal cartilage. Another nodule appeared higher up at the edge of the sternum. The nodules disappeared completely after the insertion in June, 1917, at the site of each for twelve hours, of a 50 mg. tube of radium with a 1 mm. platinum screen. In September, 1917, there was some general swelling of the arm, but not to a serious extent. In October, 1917, Mr. T. H. Ionides of Brighton detected a lump at the outer edge of the right latissimus dorsi. X-rays failed to reduce this nodule, and I excised it. A section showed degenerate but still living carcinoma cells. All this time the patient's general health was good and she had very little pain. In July, 1918, a lump appeared in the right supraclavicular region, and this was successfully treated by burying a tube of radium. In December, 1918, a skiagram of the chest by Dr. Prowse showed no sign of secondary deposit. Her husband wrote that she "seems wonderfully well and certainly looks it." The slight swelling of the arm continued much as it was, with variations from time to time. Up to November, 1920, this lady had developed no fresh signs or symptoms. Thus three and a half years after the first recurrence the disease remains in abeyance, and meantime the patient has lived a comfortable and almost normal life.

CASE IV.—Supraclavicular Recurrence Successfully Treated by Operation and Radium: Death from Thoracic Deposits.

Mrs. H., aged 59, was sent to me by Dr. Simson, of Grosvenor Street, in January, 1914. In the previous year another surgeon had removed a carcinoma from the left breast. She now had enlarged glands in the left posterior triangle, which upon removal on January 4th, 1914, were found to be carcinomatous. In April, 1914, her general condition was satisfactory and she was free from pain, but two or three small nodular recurrences were present in the posterior inferior angle of the posterior triangle. They were treated by burying a tube of radium. Radium treatment was repeated in 1914, and in November, 1914, the nodules had disappeared. About this time she had developed

bronchial symptoms, and she shortly afterwards died with thoracic recurrence. In this case radium combined with operation probably averted pressure upon the brachial plexus and thus made the patient's end a comparatively easy one.

CASE V.—Recurrence in the Left Supraclavicular Glands: Excision and Radium Treatment: Rapid Recurrence at the Base of the Left Pleura.

Mrs. H., aged about 45, was sent to me in 1916 by Dr. Hobart of Cork. The left breast had been removed for carcinoma in 1914. The left supraclavicular glands were hard and enlarged. There was no other sign of recurrence. I excised the glands, leaving a tube of radium in the wound for twenty-four hours. Three months later there was evidence of pleural growth at the base of the left lung, and the patient did not long survive. There is, however, reason to think that the operation saved her from nerve pressure upon the brachial plexus. This case illustrates the disappointments that may be met with in the treatment of recurrence, and shows that an x-ray examination of the chest should always precede operation in such cases.

CASE VI.—Intercostal and Supraclavicular Recurrences Suppressed by Radium: Later Signs of Thoracic Metastases.

A. B., aged 55, was operated upon by me for cancer of the left breast in August, 1915. In December, 1917, a lump appeared in the second left intercostal space, but she ignored it until March, 1919. In April, 1919, two 50 mg. tubes of radium were introduced into the first and second space, and by June 16th the lump had disappeared. In October, 1919, there was no return, but slight prominence and tenderness had appeared over the right half of the first piece of the sternum and radium tubes were introduced here. In November, 1919, the patient came up stating that she had never been so well before, but on examination two hard glands were felt in the left supraclavicular triangle. On January 1st, 1920, four tubes of radium, 200 mg. in all, were introduced into the left supraclavicular triangle, the left axilla, and the right sternal region. On March 3rd, 1920, no glands whatever could be felt, but there was shortness of breath and some dullness at the left base; probably there is infection of the lungs and pleural cavity and the patient's days are numbered. But radium has kept her comfortable almost to the end and has given her an extra year of enjoyable life.

CASE VII.—Intercostal Recurrence: Improvement under Radium Treatment.

C. A., aged 68, was operated upon for carcinoma of the right breast at St. George's Hospital in 1917. In March, 1919, she attended the Middlesex Hospital for a recurrent fluctuating mass with reddened skin at the inner end of the fourth right intercostal space. It was incised, but no pus escaped, and was evidently a mass of degenerate growth. She was admitted for radium treatment, and in June, 1919, only a thick scar remained at the site of the lump. In October, 1919, the lump was again increasing, and there was vague induration of the left breast and enlargement of a left axillary gland.

CASE VIII.—Intercostal Recurrence: Radium Treatment: Relapse after Great Initial Improvement.

Kate G., aged 59, was operated upon in January, 1913, for carcinoma of the left breast. In March, 1914, a swelling was noticed over the manubrium. In June, 1914, two 50 mg. radium tubes with $\frac{1}{2}$ mm. screens were inserted for twenty-four hours. A second application was given in November, 1914. In December, 1914, the lump over the sternum had disappeared except for one slight local thickening. In February, 1915, there was no sign of growth, but in May, 1915, there was some thickening at the left margin of the sternum. The patient shortly afterwards ceased to attend.

CASE IX.—Late Intercostal Recurrence: Successful Treatment by Radium: Patient Well Two Years Later.

A. L., aged 58, was operated upon in 1906 by Sir A. Pearce Gould for carcinoma of the left breast. She remained well until September, 1918, when a lump appeared at the inner end of the second left intercostal space. It was a fixed induration adherent to the bones. On November 23rd, 1918, a 50 mg. tube of radium with 1 mm. platinum screen was buried under the lump for twenty-four hours. On December 1st the lump was much smaller, and on April 9th, 1919, no trace of a lump could be detected. In January, 1920, there was no trace of a return of the lump, but a suspicious fullness was present over the inner end of the first space. In March, 1920, tubes of radium were buried at the inner end of the first and third spaces in order to anticipate events. Patient remains well June, 1920.

This case goes to show that the later the time at which the recurrence first appears the more likely is it to be amenable to radio-therapy. This impression cannot yet be submitted to a statistical test.

CASE X.—Intercostal Recurrence Seven Years after Primary Operation: Disappearance under Radium.

A. G., aged 52, attended at the Middlesex Hospital in February, 1920, for a fixed intercostal recurrence in the second left space. The left breast had been removed for carcinoma seven years previously. After radium treatment the sternal recurrence completely disappeared, but an enlarged gland could now be felt in the lower and inner angle of the left posterior triangle.

CASE XI.—*Intercostal Recurrence Refractory to Radium Treatment.*

Emma M. in June, 1916, was operated upon for carcinoma of the right breast. She attended the Middlesex Hospital in July, 1917, for a typical intercostal recurrence in the first right space. Two 59 mg. tubes of radium with $\frac{3}{4}$ mm. screens were introduced into the lump on November 7th. In the following January no diminution in the lump had occurred, and in February the lump involved the second space as well as the first, and recourse to sedatives was necessary.

This case suggests that results are better with a 1 mm. screen than with a thinner screen, a suggestion borne out by my experience in other cases.

CASE XII. *Intercostal Recurrence One Year after Operation: Treatment by Secondary X Rays: Patient still Well, Ten Years after First Operation.*

Mrs D., aged 61, noticed in 1909 a small kernel in her right breast. She consulted me in March, 1911. A lump $1\frac{1}{2}$ in. in diameter, adherent to the fascia, was present in the upper and inner quadrant of the right breast. The glands in both axillae were enlarged, especially those on the right side. The growth proved to be a cellular one of duct origin, and many of the epithelial masses showed central degeneration. Prophylactic x rays were given after the operation. In May, 1912, nodules were noticed in the second, third, and fourth right intercostal spaces at their inner ends, and one or two nodules further out along the intercostal spaces. Bismuth carbonate injections were made at the inner ends of the affected intercostal spaces, and subsequently another course of x rays was given. The patient followed my advice to live an open-air life. By September, 1912, no trace of the nodules remained. One doubtful nodule was felt over the upper end of the sternum, and here and in the fifth intercostal space, where a slight thickening remained, bismuth was again injected. The x rays were continued.

There was no doubt of the recurrence, for the nodules were definite and rounded. At the present time (January, 1920) there is no trace of them, and the patient remains well. In 1918 she had some enlargement of the left axillary and supraclavicular glands, but this has subsided under x rays. The method of secondary x rays employed in this case has been superseded by the use of radium.

CASE XIII.—*Intercostal Recurrence Five Years after Operation for Breast Cancer: Radium Treatment: Patient Well nearly Two Years Later.*

Mrs. S., aged 28, noticed early in January, 1912, a lump in the left breast. She consulted me on January 18th, 1912. There was no skin adhesion but some fascial fixation, and very marked mastitis in the right breast. Preliminary exploration showed that the tissue looked like mastitis, but immediate examination showed it to be malignant. The great pectoral was removed except uppermost clavicular fibres, and the lesser pectoral and serratus left. The supraclavicular region was not explored. A small piece removed from the right breast was innocent chronic mastitis. Prophylactic x rays were given after the operation. In October, 1912, there was no sign of recurrence whatsoever and perfect mobility. The patient, who was a keen sportswoman, played golf during the summer, and won two medals within six or seven months of the date of operation. In 1917 there was a tiny lump at the junction of the upper border of the left second costal cartilage with the sternum, and the patient was given another course of x rays. In December, 1918, there were two small recurrences in the second and third left intercostal spaces. The patient had been doing very hard muscular work which may have predisposed her to these. I removed the recurrence in the second space and had it microscopically examined. I put in two tubes of radium, one in each space, and a week after the nodule in the third space had disappeared.

At the present time (October, 1920) there is no recurrence, and the patient looks well.

Question of Treating Operable Breast Cancer by Radiation.

I have met with one case in which a persistent effort was made to treat a carcinoma of the breast by x rays without operation.

CASE XIV.—*Operable Cancer Unsuccessfully Treated by X Rays.*

Mrs. A. noticed a lump in the left breast in 1913. In the summer of 1916 she consulted a medical man who has had extensive experience in x rays, and who made a diagnosis of cystic disease of the breast. X rays were applied to the breast on fourteen occasions. The lump became smaller and a pucker appeared on the skin. The patient was thereupon advised to consult me. I saw her in January, 1917, and found a puckered scar over the upper and outer quadrant with slight subjacent induration. There was no adhesion to fascia, and no glands were felt. Section after operation showed a carcinoma. The epithelial cells were in small groups and many of them were degenerate. The glands were unaffected.

Apparently in this case the radiation exerted a deterring and delaying effect on the growth, and perhaps prevented its spread to the axillary glands, but there was no evidence of cure. The history of this case goes to justify the belief usually held that operable cancer should not be treated by radiation only. The exceptions to this rule

are (1) if the patient refuses operation; (2) in old and feeble subjects with atrophic cancers; (3) grave constitutional disease—for example, cardiac or renal disease or diabetes.

Treatment of Inoperable Primary Growths by Radium.

In cases where operation is excluded by the advanced stage of the growth, age, or constitutional disease, much benefit may be derived from the use of buried radium. The primary growth may even completely disappear, or short of this ulceration may be averted, a very great gain to the patient's mental and bodily comfort. So far, however, there is no proof that by the imperfect methods at present in use the spread of the disease is arrested.

The following cases illustrate the treatment of inoperable growths by radium:

CASE XV.—*Advanced Primary Growth of Breast: Great Local Improvement after Radium.*

A. H., aged 37, attended the Middlesex Hospital in December, 1914. The whole of the right breast was infiltrated by carcinoma and firmly adherent to the chest wall. There were very numerous nodules around the breast, and especially on the outer side. A mass of enlarged glands was present in the axilla and just above the clavicle. On December 9th, 1914, four tubes of radium, 187 mg. in all, were inserted into the right breast for twenty-four hours. On January 26th, 1915, the infiltration of the breast had almost disappeared and the organ had become freely movable; the nodules also were shrunken. Two slight areas of radium dermatitis were present over the sites of the insertion of the tubes. The patient ceased to attend.

CASE XVI.—*Inoperable Cancer of the Breast Treated by Radium: Marked Local Improvement, but Continued Centrifugal Spread.*

M. A. S., aged 49, attended the Middlesex Hospital in November, 1916, with an ulcerated mass in the lower part of the right breast and universal induration of the breast. There were hard glands in the axilla. In December, 1916, radium was inserted into the axilla and breast. The glands disappeared within a month, and the upper part of the breast was soft and slack. Growth reappeared in the supraclavicular region, and in January, 1917, extensive nodular skin deposits were present around the breast. Further treatment was deemed useless.

This case well illustrates the usual history of carcinoma of the breast treated by radium alone. There is marked local improvement, but the centrifugal spread of the disease continues unaffected. Such cases appear to show that, if possible, treatment by radium should be applied first to the peripheral growing edge, and later in a centripetal manner to the primary growth. But the practical difficulties involved are great.

CASE XVII.—*Inoperable Carcinoma of the Left Breast: Radium Treatment: Disappearance of the Primary Growth, but Extension of Growth in the Glands of the Axilla and Neck in spite of X Rays.*

A. A., aged 61, attended the Middlesex Hospital in July, 1915, for a lump in the axillary margin of the left breast. The skin was adherent and the supraclavicular glands on the left side were much enlarged. Treatment by buried radium. In October, 1915, the supraclavicular glands were palpable and hard, but not enlarged, the primary tumour had disappeared, leaving only a vague induration. In December, 1915, no lump whatever could be felt in the breast. In April, 1917, the primary growth had not recurred, and there was merely an adherent scar, but there were large masses of nodular glands in the axilla and above the clavicle. X-ray treatment was being continued.

This interesting case illustrates that the complete disappearance of the primary growth does not mean the arrest of the disease. I have seen the same thing happen after radium treatment of carcinoma of the lip—complete cicatrization of the primary growth, and later the appearance of a mass of secondary glands.

CASE XVIII.—*Disappearance of Primary Growth under Radium.*

Mary W., aged 49, attended the Middlesex Hospital in February, 1916, for a cancer occupying the centre of the left breast. Radium was inserted on February 29th, and on March 29th the growth had almost entirely disappeared, though glands could still be felt in the left axilla. The patient was subsequently lost sight of.

CASE XIX.—*Carcinoma Treated by Radium without Operation: Growth in Check Two Years later.*

F. A., aged 60, in June, 1917, noticed a lump in the left breast. In June, 1918, when she sought advice, there was a carcinoma in the breast the size of a large orange, immovable and attached to the skin. The glands in the left axilla were enlarged. She refused operation and was admitted in August, 1918, for treatment by buried radium tubes. On September 11th the breast was much smaller, softer, and more mobile—an extraordinary improvement. In October, 1918, an induration, possibly a second primary carcinoma, appeared in the upper and outer quadrant of the opposite breast, and she was sent for x-ray treatment. In April, 1920, no further developments had occurred, and the growths appeared to be still in check.

Radiation as a Preliminary to Operation.

Dr. N. S. Finzi believes that it is advisable to give a large dose of x rays just prior to operation, and I am inclined to think that the practice is a sound one, though its value is not easily susceptible of proof. It should not be allowed to delay operation. Recent work at the Middlesex Hospital goes to prove that the resistance of the patient to carcinomatous infection may be increased by a small dose of radiation prior to operation.

There is no doubt that radiation frequently converts an apparently inoperable tumour into an apparently operable one. I have met with three such cases during the past year.

Natural Cure of Cancer in Relation to X-Ray Treatment.

It is not possible to form a correct estimate of the value of radiation in cancer without taking into account the natural tendency of the disease to undergo local repair. In a lecture on this subject I came to the conclusion that "Every aggregation of cancer cells, after increasing in size for a varying period and for a varying rate, tends spontaneously to undergo certain degenerative or regressive changes. These changes begin at the centre of the mass, spread centrifugally to its circumference, and may terminate in the replacement of the mass of cancer cells by a fibrous scar."

These changes, which are exemplified in the ulceration of a primary growth and in the umbilication of secondary deposits in the liver, appear to depend upon a breakdown of the improvised vascular commissariat of the growth and upon the harmful internal pressure produced by the active proliferation of the cancer cells. These degenerative changes can be seen beginning even when the collection of cancer cells is still of microscopic size, as is a permeated lymphatic. Their onset is invariably accompanied by the advent of collections of lymphocytes to the neighbourhood. It is thus possible that in every carcinoma we have to deal with a comparatively small number of perfectly healthy and active cancer cells and with a large mass of more or less degenerate and dying cells. The former class of cell is to be found in the permeated lymphatics of the microscopic growing edge and at the edge of microscopic nodules of growth which are still in the actively infiltrating stage. It seems likely that these two classes of cell differ widely in their reaction to radiation. It is probable that the crowds of degenerate cells which constitute the mass of a carcinoma may fall a ready prey to the reaction of radiation. Even the earliest attempts at the destruction of secondary nodules by x rays were often locally successful. The shrinkage and disappearance of local masses of cancer may possibly indicate nothing more than the acceleration and completion of this natural process of destruction.

The Prophylactic Use of Radium at the Time of Operation.

Having considered and rejected the idea of extending the scope of the primary operation to include removal of the supraclavicular and the anterior mediastinal glands, I determined at the end of 1919 to try another plan to meet the deplorable frequency of intercostal and supraclavicular recurrence.

If in a considerable proportion of cases, at the time they come to operation, microscopic colonies of carcinoma cells are present in these glands, it may be fairly hoped that vigorous irradiation applied to the glands as directly as possible may destroy these colonies. There is the further possibility that a general immunizing action may be at the same time secured.

Prior to the closure of the main operation wound, a 25 mg. tube of radium is pushed under the intercostal fascia at the inner end of the first space. A similar tube is placed in the same way at the inner end of the second space, and it might be advisable, if a third tube is available, to place it at the inner end of the third space. The threads attached to these tubes are brought out through the line of incision or through separate stab wounds, as may be convenient. A 50 mg. tube of radium is now introduced under the deep fascia in the lower and inner angle of the posterior triangle, the situation where the first evidence of supraclavicular recurrence is usually found. This tube is introduced through a small stab

wound. The radium is screened with 1 mm. of platinum; it is left in place for twenty-four hours and is withdrawn at the first dressing.

The following is the first case in which I used the method.

CASE XX.

A young lady of 32, six months pregnant and in vigorous general health, was brought to me in December, 1919, with a rapidly growing mastitic carcinoma of the upper and outer quadrant of the left breast. The axillary glands were enlarged. The growth was evidently very malignant, and the pregnancy as well as the youth and vigour of the patient made the outlook a bad one, but I urged an immediate operation, to be combined with the use of radium, and my advice was accepted. The pregnancy continued undisturbed, and resulted in a very fine healthy infant. Subsequently x rays were administered by Dr. Finzi. A section showed an exceedingly active and cellular growth with hardly any stroma. The patient was not permitted to suckle her child. At present (November, 1920), nearly a year later, she remains well.

This case was exactly of the type in which an early fulminating recurrence seemed inevitable, and its result to date is distinctly encouraging. I have since made the use of prophylactic radium a routine practice wherever possible. If the method establishes itself it will be necessary for surgeons dealing with breast cancer either to possess or to have access to the necessary amount of radium.

The use of radium in this way seems perfectly safe, if it is kept well away from the skin. The only drawback I have to report is that in several cases brachial neuralgia, lasting for several months, and accompanied in one case by a small trophic slough in the region of the elbow, has occurred. I shall therefore, in future, use a 25 mg. tube instead of 50 mg. in the supraclavicular triangle, and as a security against secondary radiation I propose to enclose it in a rubber sheath.

I await the results of this method with interest and hope, encouraged by the fact that no recurrence has yet taken place in any of the cases treated during the past year.

Open-air Treatment.

In conclusion, I should like to urge the importance of open-air treatment, both for its prophylactic value against recurrence and in the more chronic varieties of inoperable cancer. In cancer, as in tubercle, the natural defences of the body are to be partly found in the processes of inflammatory and fibrotic reaction. Clinical experience of the value of open air in tubercle shows that these processes are stimulated by fresh air.

ABSTRACT OF A LECTURE

ON

SUBACUTE BACTERIAL ENDOCARDITIS.*

BY

BASIL PARSONS-SMITH, M.D., M.R.C.P.

PHYSICIAN TO OUT-PATIENTS, THE NATIONAL HOSPITAL FOR DISEASES OF THE HEART; HEART SPECIALIST, MINISTRY OF PENSIONS.

THE subject of this lecture—subacute bacterial endocarditis—has been selected primarily because it happens to be one of those states of disease which warrants a wider recognition, and because clinical observation and experience offer abundant and ever increasing evidence of the high rate of incidence of the condition. In spite of the mass of convincing and definite conclusions arrived at by the pioneer investigators, subacute bacterial endocarditis is a disease which is very frequently overlooked entirely. To some extent this may possibly be accounted for by the fact that the condition is one of slow and insidious onset, more often than not arising in patients already suffering from cardiac disease itself of such a nature as to explain apparently, in perfectly satisfactory fashion, any degree of cardiac failure which may be present. Valuable indications, however, later to be discussed, enable us to realize that valvular lesions, typically quiescent, may become the seat of a fresh infection which will influence profoundly the whole outlook of the patient, and materially alter the prognosis. The whole position will be simplified if we are prepared to appreciate the presence of signs of active infection in patients suffering from a hitherto quiescent lesion.

* Delivered at the National Hospital for Diseases of the Heart, November 29th, 1920.

Real and weighty difficulties do, however, exist, for it must be admitted that we are still very far from the day when exact and tangible evidence will definitely enable us to understand and appreciate the features significant of the actual onset of infective endocarditis of the subacute variety. At the moment our situation is unsatisfactory. Certainly we can diagnose the disease without difficulty in its fully developed form by signs and symptoms which are unmistakable in character, but we know full well that this stage of the malady having been reached there can only be a fatal termination.

Obviously, therefore, it is our business as clinicians to search most carefully and assiduously for early indications of the presence of the infective process, for it would seem that, unless we can perfect our knowledge from this point of view, our chance of being able to employ successful treatment is exceedingly remote.

Before describing in detail the more important features of the subacute variety of bacterial endocarditis, it will possibly be of some advantage to review for a moment our conception of the types of disease which result from endocardial infections.

It is customary to divide endocarditis into two main groups: (1) The simple or benign; (2) the ulcerative, infective, or malignant. This division is arbitrary; useful from the clinical standpoint but of little value as regards etiology, pathology, or morbid anatomy.

The underlying process is similar, but the degree of intensity varies in the two groups, and all gradations are represented. In the milder forms of the disease organisms are not found; this may reasonably be explained by the fact that endocarditis is known to run a latent course in certain cases without modifying the symptoms of the primary affections to any appreciable extent, so that the early stage is altogether missed. Here we may suppose that the endocardial damage is either the work of short-lived organisms—very possibly of low virulence—or the result of the spread of toxins in the circulation. The endocardial damage, which is so frequently associated with acute rheumatism, exemplifies this benign or simple category. Here the early infection betrays itself unmistakably: the fever, which may have subsided, develops again, the pulse becomes rapid and irregular, the apex beat is noticed to be wavy and forcible, extending well outwards to the left, the shock of the heart sounds is exaggerated, and the sounds themselves become blurred in character. These signs are indicative of the first stages of endocardial infection; the later developments vary in individual cases, giving rise to all degrees of incompetence—myocardial, valvular, etc.

With regard to the second group—the ulcerative or malignant type of endocarditis so-called, in which the heart lesion is secondary to, rather than responsible for, a systemic pyaemia or septicaemia—a brief statement will suffice to explain the sequence of events which, taken collectively, constitute this grave disease. First, it is necessary to assume some primary focus of acute infection, a generalized blood invasion therefrom, and secondary lesions, ulcerative in character, of the cardiac valves or endocardium; depending largely upon the seat of the primary focus, also upon the variety of organism concerned, we must of necessity be prepared for physical signs widely varied in type, hence the grouping, which has been adopted from the clinical standpoint, into the three types—cardiac, pyaemic, and typhoid. We need not proceed to discuss these in detail, the special features which characterize each can be appreciated without difficulty; suffice it to say that the disease, in any of its forms, progresses with extreme rapidity, the duration usually being limited to a few days or weeks.

Subacute bacterial endocarditis may be said to occupy a position midway between the simple and the fulminating types of the disease; its title is fully descriptive, and will at once suggest in some measure the clinical aspect of the condition.

During recent years this variety of endocarditis has attracted considerable attention; an increasing number of cases seem to come under observation. One should not, however, conclude, without very careful investigation, that this disease is becoming more frequent in incidence, for in dealing with this matter several factors must be faced, not the least of which is our conviction that fewer cases are overlooked nowadays than formerly. We are tending, in fact, to become more familiar with the disease, and

there is a general agreement that diagnosis need present no difficulty, so characteristic is the clinical aspect of the condition.

The onset of the disease is usually insidious, and symptoms are not necessarily pronounced. An ill-defined malaise, general debility with loss of strength and tone, erratic and fleeting pains in the joints or limbs—each or any of these may be the only indication from the patient's point of view of the earlier stages of the disease. Symptoms of cardiac failure—dyspnoea, palpitation, giddiness—may be noted, but as often as not will fail to manifest themselves until the disease has become fully developed. One realizes, therefore, that the symptoms of subacute bacterial endocarditis are far from being precise—in fact, more often than not they appear to be extremely vague. Not so the physical signs, which present an unmistakably clear-cut clinical picture: examination of the heart shows in every instance the presence of an organic murmur at the aortic or mitral regions; apart from the murmur, the heart may show little or no evidence of functional disturbance during the course of the disease; beyond a simple tachycardia the rhythm, as a rule, remains unaffected, the myocardium retains its power, venous stasis does not develop—in fact, one may follow the entire progress of the disease without noting at any time a full development of the true signs of cardiac failure. In other words, we can very reasonably conclude that the endocarditis does not represent or explain, in anything approaching adequate fashion, all the signs and symptoms which we have learnt to associate with this disease, and furthermore we can readily understand the prevailing idea of the nature of the malady—namely, that it is a general systemic disease depending upon a bacterial invasion whose seat of origin is localized at some focus of chronic or quiescent valvulitis.

Clinically, therefore, we may expect in this type of case to find a series of important signs which we are not in the habit of associating with valvular disease of the heart in its uncomplicated forms: pyrexia will be present at some period during the progress of every case; the type of curve is irregular, remissions and apyrexial intervals are frequent, rigors and sweats are common. Examination elicits numerous confirmatory phenomena; of these there are three—namely, pallor, enlargement of the spleen, and clubbing of the fingers—which, taken together, may conveniently be referred to as the diagnostic triad of the disease. The pallor suggests a profound secondary anaemia, and the dusky sallow tinge is indicative of the septicaemic state. The clubbing of the fingers and toes is insidious in onset, develops later with extreme rapidity, and, curiously enough, the patient is as often as not quite oblivious to the change which is in progress; the regularity of this sign will at all times materially assist diagnosis.

Other signs are forthcoming during the progress of the disease, and include multiple arterial embolism, renal insufficiency, haematuria, positive blood culture, sternal tenderness, loss of weight, progressively increasing anaemia, and, accompanying the secondary lesions in the final stages, varying degrees of leucocytosis.

Time does not permit an exhaustive description of the large variety of embolic phenomena which characterize this disease; objectively we recognize their presence without difficulty in the majority of instances; especially is this so with infarction of moderate sized vessels, as, for instance, those of the spleen, kidney, brain, or extremities. Other emboli, however (the smaller varieties and those microscopic in size) produce results equally significant—cutaneous petechiae, painful nodes, and discoloured patches on the terminal phalanges of the hands and feet, arthritic inflammations, embolic aneurysms, etc.

A blood culture must be attempted in every case that comes to our notice, but a negative result should not deter us from further efforts to cultivate the organism. In spite of the fact that we have as yet insufficient evidence to dogmatize, I feel that the variety of endocarditis at present being considered is not the result of any one specific organism: several types have been found, including pneumococci, gonococci, the influenza bacillus, and small streptococci. In the opinion of Libman, whose researches entitle him to speak with authority, these subacute varieties of endocarditis are due to the *Streptococcus anhaemolyticus* in about 95 per cent. of the cases. The other 5 per cent. are due mainly to the influenza bacillus; but an additional case will be due to the gonococcus or *Micrococcus flavus*.

It does happen, however, that the blood culture is persistently returned as negative in certain cases of indisputably infective endocarditis. The explanation for this is not easy; three suggestions may be made:

1. That organisms are present in the blood stream, but of a type which defies our present methods of culture.
2. That the bacteria, though massed on the cardiac vegetations, are not circulating in the blood stream.
3. That the vegetations, and the blood stream also, have become bacteria-free.

In support of the two latter suggestions proof of a definite character may be quoted, certain cases having been recorded in which a completely sterile blood stream has been associated with endocardial lesions demonstrated *post mortem* to be teeming with bacteria; in other cases with negative blood cultures examination of the crushed vegetations entirely fails to reveal the presence of bacteria. The whole subject of blood cultivation in subacute bacterial endocarditis is undoubtedly important, and needs further investigation; our present state of knowledge, however, enables us to state quite positively that, for purposes of diagnosis, a positive blood culture is certainly not essential.

With regard to prognosis, we have unfortunately grounds for extreme precision: the disease is invariably fatal; three to twelve months may be looked upon as an average period, though the patient may drag on slightly longer in some instances. The progress of the disease is relentless and rapid; infective emboli are responsible for widespread and lasting lesions, and incidentally cause a large part of the suffering which these patients undergo. The cause of death is cerebral embolism, or haemorrhage, uraemia, progressive anaemia, or intercurrent pneumonia.

The abbreviated notes of two patients recently admitted to this hospital will illustrate, from the clinical point of view, some of the features which characterize the progress of the disease.

CASE I.

G. W., aged 36, pensioner. Admitted September 14th, 1920; died November 7th, 1920.

Past History.—Negative except for trench fever in 1917. The serum test was negative. Onset of symptoms June, 1920: Dyspnoea, palpitation, pain under heart with exertion, slight cough; no haemoptysis; loss of weight.

On admission (September 14th) the physical signs were pallor, clubbing of fingers, enlargement of spleen and liver, oral sepsis; heart enlarged; free aortic reflux; lungs engorged.

Progress.—Patient was in hospital three weeks, and, during this period, the condition became steadily worse; fever of an intermittent character persisted, petechial haemorrhages were observed from time to time; sweats, rigors, and all the usual concomitants of septicaemia, complicated the final stages, and death took place on November 7th, barely five months after the onset of the initial symptoms.

CASE II.

S. B., aged 26, pensioner. Admitted September 1st, 1920; died September 25th, 1920.

Past History.—Negative. Discharged from the army March, 1917, for gunshot wound, face and neck. Serum test negative.

Onset of Symptoms.—May, 1920, palpitation after exertion, shortness of breath, vertigo, and fainting attacks.

Physical Signs on Admission (September 1st, 1920).—Pallor, anaemia, and poor nutrition; fingers clubbed; heart enlarged, free aortic regurgitation, vessels thickened, pulse collapsing in quality; liver and spleen enlarged and tender; petechial rash on neck and upper thoracic region; urine, heavy cloud of albumin and blood cells numerous.

Death from cerebral embolism on September 25th, five months after the first onset of the symptoms of the disease.

The *post-mortem* appearances in patients who have died of subacute bacterial endocarditis bear ample witness to the widespread nature of the disease. The heart is enlarged in most instances; the endocardium and valves are the seat of gross changes in the shape of extensive vegetations, which vary very considerably in appearance and consistency: the older lesions are usually firm, greyish, and calcareous, the most recent reddish-yellow and extremely friable.

The valves involved are the mitral and the aortic, the latter more frequently than the former; in the majority of instances, however, the infective process spreads from the primary seat of infection, both to the adjacent endocardial wall and to the neighbouring valve; under these circumstances one notices that the oldest infection is the most extensive. It is important to observe that the right side of the heart is never involved, furthermore that the endo-

carditic process is of a purely vegetative character, ulcerative lesions playing no part in the condition.

A large number of conditions found *post mortem* elsewhere than in the heart might be mentioned; they depend in every instance upon embolic processes which may very obviously affect the arterial channels in any part of their course, and determine the production of visceral infarcts or haemorrhagic, mycotic aneurysms, etc.

Treatment.

Treatment should follow the broad lines adopted for any form of septicaemia: rest in bed should be absolute, the diet should be light and easily digestible; the action of the bowels must be free; drugs are of little value, though some temporary benefit may follow the prescription of tonics such as iron, arsenic, and quinine. Strychnine, by reason of its effect on the vasomotor centre, and digitalis, may be employed for symptomatic reasons and will sometimes assist in tiding over critical periods.

Intravenous injections of collargol and other metallic and antiseptic substances have been tried without success, no useful purpose therefore can be served by advising treatment of this nature.

Vaccines should be given a trial in all cases, but, in the experience of most observers, their remedial effect on the disease, in its fully developed stage, must be considered to be small.

The whole subject of treatment in this disease forces upon us the conclusion that subacute bacterial endocarditis, in the stage which permits diagnosis by gross physical signs, is an inexcusable malady. This being so, our duty becomes clearly defined: we must endeavour to recognize the initial stage of the disease, the early evidence that fresh infection has developed upon some old and quiescent lesion, the origin of the infective process, the factors which permit of its spread, the influence of a lowered tissue resistance, etc., for we know full well that, until we possess reliable data concerning the preliminary phases, our chances of lessening the mortality of this dread disease are wholly insignificant.

AN OPERATION FOR THE RADICAL CURE OF PRE-MASSETERIC FISTULAE OF STENSON'S DUCT.

BY

GILBERT CHUBB, D.Sc., M.B., F.R.C.S.

SURGEON, THROAT HOSPITAL, GOLDEN SQUARE, AND PLASTIC SURGEON,
QUEEN'S HOSPITAL FOR FACIAL INJURIES, SIDCUP.

The ideal treatment for this condition is the restoration of the continuity of the duct (Nicoladoni). This, however, must always be difficult, and in any but recent cases must be impossible. An alternative method is to dissect out the duct, sever it from the fistula, and turn it into the mouth (Languebeck, also Riberio). As the original cause of the fistula usually produces considerable local scarring, this also is an operation that can only occasionally be successful. A large group of operations aim at the formation of an internal fistula, either by means of a ligature causing sloughing of the tissues between the duct and the mouth cavity (Deguise and P. Gould), or by means of a small tube passed through from the fistula into the mouth (Kauffmann's modification of Descault's operation). All these methods are tedious and at the best uncertain. If these fail it is recommended either to ligature the duct, admittedly entailing the risk of abscess formation in the gland,* or to dissect and remove as much of the gland as possible without damage to the facial nerve. This method admittedly produces disfigurement, but is regarded as preferable to a persistent salivary fistula.

The number and varied character of the methods described for the treatment of this condition, and the drastic

* As an alternative to this method, when a considerable portion of the duct is destroyed, or much fibrous tissue is present, Dujardin and Guillemin (*Ann. Chir. Soc. Ex. le Chir.*, October, 1900) incise in the direction of the duct and dissect up both this and the masseteric pronator, part of the gland, which is then passed between the masseteric muscle and the mandible, and stitched into the opening in the mucous membrane of the oral cavity.

† Morestin (*Bull. Ass. Méd. de Chir.*, Paris, 1917; Abstract S.G.C., 1917) made a hole to dissect out and ligature the duct, the gland subsequently degenerating. This author has done 32 cases since 1915 by this method.

nature of some of them, is a sufficient indication of their uncertain value, and has induced me to publish the operation now described. Its advantages are great simplicity and, as far as I have practised it, reliability; while it permits of the complete removal of the fistula and surrounding scar tissue from the cheek with primary union of the remaining linear incision at one operation.

I have performed this operation in three consecutive cases.¹ In two the fistula was due to a gunshot wound in the malar region, and in one it followed the external rupture of an alveolar abscess. In each case the fistula was situated immediately in front of the anterior border of the masseter, and had been in existence for over a year. In one case a course of several months' treatment with the hard x-ray tube had failed to effect any improvement, and in another the fistula had previously been dissected out and the cheek closed by a plastic operation, without alleviating the condition.

The Operation.

Two horizontal incisions, about a quarter of an inch apart, are made, the one above and the other below the fistula.



FIG. 1.—Showing the incisions. A probe has been inserted into the fistula. The triangular areas of skin on either side of the area bearing the opening are discarded.

once until it enters the mouth immediately below the reflection of the mucous membrane opposite the upper molar teeth. In one case this area of the cheek was adherent to the alveolar border owing to scarring following the injury, and was mobilized by means of an epithelial inlay some weeks prior to the operation. The probe is now withdrawn, and small cat-gut mattress sutures inserted in the anterior and posterior lips of the skin button, and drawn through the wound into the mouth. Similar mattress sutures are inserted in the lips of the opening of the buccal mucous membrane, and these are now

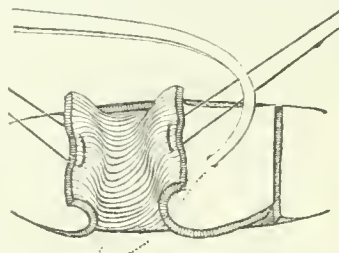

FIG. 2.—The island of skin bearing the fistulous opening in course of mobilization. Deepening the posterior incision, with probe in position in the duct.

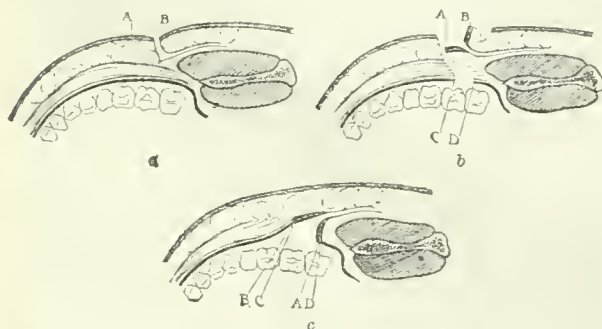

FIG. 3.—Semi-diagrammatic horizontal sections showing: a. The condition of duct and fistula prior to operation; A and B, position of incisions. b. The mobilized area of skin bearing the fistulous opening, and containing the salivary duct in its pedicle; A and B, anterior and posterior lips of mobilized skin area; c and d, lips of the opening through the mucous membrane. c. The mobilized skin area seen in b has been inverted, and its edges sewn to those of the opening in the mucous membrane. The letters A, B, C, D have the same significance as in b.

tied together within the mouth. The original anterior edge of the skin button is stitched to the posterior lip of the opening in the mucous membrane, while the posterior edge of the latter is tied to the anterior lip.

(Fig. 3, a, b, c, shows diagrammatically the successive stages in this process.) No attempt is made to mobilize the skin button sufficiently to allow of its complete reversion. If it is turned over to face forwards and slightly inwards, the elasticity and loose attachment of the oral mucous membrane will allow of the latter being drawn up to the button, the post-operative appearance in the mouth being that of a conical recess of mucous membrane, passing backwards and outwards to the fistulous opening. The lips of the original incisions are now very slightly undercut and brought together, thus covering the reversed surface of the skin button bearing the fistulous opening.

In one of the three cases the tip of a defective probe remained in the duct, and was subsequently discharged through the operation wound. This has resulted in a slight external leakage, which, however, does not amount to a complete drop during a meal. In the other two cases healing was by first intention, and the wound has remained dry since the operation, now more than two years ago. In all three cases there is now a free and normal discharge of the parotid secretion into the mouth.

ADRENALIN IN RESUSCITATION FROM APPARENT DEATH.

BY

CRANSTON WALKER, M.D., B.Sc.,

HONORARY PHYSICIAN, GUEST HOSPITAL, DUDLEY, ETC.

ANAESTHESIA, asphyxia, the passage of a powerful electric current, violent emotion, and violent sensory stimulation may place the body in a state which resembles that of a clock which has been stopped, but not permanently damaged; if the machinery can be restarted it will continue to run automatically. Relatively simple means will often suffice to set things in motion again, as a mere shake will serve to start a clock. Sometimes it appears as though a more accurately fitting stimulus were required, like a swing in time with that of the pendulum.

Mr. Welby Fisher, in a very interesting paper,¹ advocated cardiac massage applied through an epigastric incision. He makes no reference to the use of adrenalin. The following notes of a limited experience may be of interest.

Adrenalin applied to the heart muscle acts on the sympathetic neuro-muscular junction, and very greatly increases both the excitability of the tissue and the energy output of the muscular contractions. In some twenty cases of death from various causes, when all signs of life had ceased for several minutes, I have injected a minim or two of 1 in 1,000 adrenalin chloride directly into the heart muscle. A fine needle was passed through the fifth left intercostal space, just mesial to the lung resonance; the point was directed slightly inwards and upwards, and could be felt to enter the apex of the heart; when firmly imbedded in the muscle the injection was made. Several of these needle tracks were examined *post mortem*, and in no case did it appear that any drawback would have ensued had the patient survived.

In most of the cases death had occurred as the result of long established disease, and adrenalin was neither expected nor observed to have any effect (a fact not without interest). In the following three cases circumstances were more favourable.

CASE I.

A splendidly built young man had received a powerful electric shock while fitting an electric lift, and all appearance of life had instantly ceased. When seen by me it is estimated that about twenty minutes had elapsed; there were no signs of circulation, the upper parts of the body were pale, the lower were dusky, showing that the blood distribution was determined by gravity; the skin was already cool. Artificial respiration was applied, adrenalin injected into the heart muscle, the needle shaken *in situ*, the heart was massaged, but without abdominal incision, and was stimulated faradically. There was no response.

CASE II.

A child of 11 months during a circumcision under chloroform had stopped breathing, and became pale and flaccid; the pupils were dilated, no pulse could be felt, and no heart sounds could be heard. Artificial respiration was started, and the heart was massaged by pressing the fingers under the costal margin; in this case the heart could be felt, and almost gripped between the fingers. There was no response, and the body was cooling perceptibly. Adrenalin was injected into the heart muscle, and immediately the heart started beating; shortly after respiration recommenced, and in a few minutes the child appeared normal. The time was not accurately observed, but it is estimated that at least four minutes had elapsed between the stoppage of the

pulse and the injection of adrenalin. The anaesthetist's estimate is considerably greater. The child was seen at intervals for three or four weeks; not the slightest ill consequence was detected.

CASE III.

A woman of 30, with empyema, had just had an exploring needle passed into an intercostal space. Suddenly she became limp and pale, she murmured a word or two, but the sound diminished into silence. She dropped back apparently dead. The muscles were quite flaccid and motionless, no pulse could be felt nor heart movement heard; jaw and eyes were in the cadaveric position. Artificial respiration was commenced, and adrenalin was sent for. Suddenly the pulse returned, beating strongly under the fingers, the patient flushed, and a few minutes later she was sitting up and talking. She had passed through a Stokes-Adams attack, subsequently repeated. Possibly more detached observation would have detected an auricular pulsation in the jugular veins. Had the adrenalin arrived half a minute sooner a striking success might erroneously have been ascribed to it.

Although Case III shows the need for caution in interpreting results, Case II suggests that injection of adrenalin into the heart muscle may restart it when other means fail.

Conceivably the needle might be pushed on into the cavity of the left ventricle and Ringer's solution containing adrenalin might be run in under pressure through a tube and funnel; on passing through the coronary arteries the adrenalin would be brought much more intimately into contact with the heart muscle, and would reach the more excitable sinus node and auriculo-ventricular bundle. The flow of Ringer's solution, preferably oxygenated, would also supply a temporary artificial circulation. Reports on wounds of the heart suggest that the risks of passing a fine needle through the apex of the heart are small compared with those of the desperate condition in which such means would be used. The method seems sufficiently promising to invite preliminary experiments on animals.

REFERENCE.

¹ BRITISH MEDICAL JOURNAL, November 6th, 1920, p. 693.

Memoranda:

MEDICAL, SURGICAL, OBSTETRICAL.

COMPLEMENT FIXATION TESTS IN THE DIAGNOSIS OF TUBERCULOUS INFECTIONS.

(A Preliminary Note.)

ONE of the writers began to study complement fixation tests in the diagnosis of tuberculous infections in the autumn of 1919. He was joined by his colleague later in the year. Our work is not yet finished, but it is hoped that the results will be advanced sufficiently for publication within a few months.

Complement fixation tests in tuberculosis have been studied by numerous workers since 1901. Varying results have been obtained, attributable to differences in technique and the characters of the antigens used.

We have attempted (1) to test the relative value of types of some of the chief antigens which have been used in the past; (2) to devise a reliable technique. We have tested four antigens up to the present time:

- (a) A saline emulsion of living tubercle bacilli.
- (b) An alcoholic extract as proposed by Craig.
- (c) An alcoholic extract as used by Dudgeon.
- (d) An antigen prepared by Wang and Crockett's method.

We find, on the whole, that the antigen of Wang and Crockett is reliable, and probably the best one that has been used to any extent up to the present time. With this antigen, and using a technique modelled on the ordinary Wassermann methods, we have tested cerebro-spinal fluid and serum from cases of tuberculosis, and from non-tuberculous cases, including normal serums and serums from patients suffering from various diseases. We obtained 61 positive results in 85 cases of definite active tuberculosis, and negative results in 50 non-tuberculous cases. We also obtained some positive reactions with serums giving a strongly positive Wassermann reaction, as previously found by Wang and Crockett. Our work is now being applied mainly to the investigation of tuberculous disease in children.

ARTHUR SELLERS, M.D.
E. N. RAMSBOTTOM, M.D.

The Public Health Laboratory,
Manchester University.

LETHARGIC ENCEPHALITIS.

As it has been my fortune to see no less than seven cases of this disease in the past fortnight, though previously for some months I had met with no fresh case, it would appear that a temporary recrudescence of intensity of the epidemic is occurring. The virulence of infection also has not notably lessened, two of these cases having already died.

As with all diseases named after a prominent symptom, lethargy is not an invariable occurrence in this form of encephalitis, and one feature that has been prominent in at least two of my recent cases, namely, quiet delirium and delusions, may lead to a mistaken diagnosis of insanity; indeed, one of my patients was brought to me by his friends from a distant suburb because the doctor in attendance said it was a mental case and should be sent to an institution. Another I have just seen has been treated for nine weeks for nervous breakdown, as he complains that his brain is not right. He has been observed frequently talking to himself about business troubles, worried much about his bladder, unnecessarily so according to his wife, and one day said to his doctor that he had 37s. 6d. in his bladder which he wanted to pass! He showed no drowsiness and was allowed to go about as usual, but the clue to recognition of the encephalitis lay in his mask-like facies resembling paralysis agitans, with marked tremor of one hand, small irregular pupils reacting poorly to light, and a pulse of 90.

Many patients complain early of blurring of vision, scarcely diplopia, and then nystagmus is usually present, perhaps most intense on looking downwards. Pyrexia of 101 F. or more and a rapid pulse are bad signs, the prognosis as regards life being almost in proportion to the degree of tachycardia. Quite a number of cases show no ptosis or drowsiness, and with the absence of ocular symptoms the recognition of this disease may be overlooked unless its present prevalence be constantly kept in mind. In others muscular twitchings are prominent, and sometimes headache, though usually no pain in the head is complained of.

It is important that cases of this disease should be kept at rest and free from worry, using sedatives and hypnotics, such as ammonium bromide and chloralamide if required, in order to limit the liability of permanent cerebral lesions occurring, which have been only too frequent. Many such cannot be avoided, one of the commonest being a permanent mask-like rigidity and perhaps tremor, resembling paralysis agitans closely, and due to lesions in the lenticular nucleus, as in that disease.

London, W. WILFRED HARRIS, M.D., F.R.C.P.

A CASE OF CARDIAC MASSAGE.

AFTER reading Mr. Fisher's article on resuscitation in death under anaesthesia in the JOURNAL of November 6th, 1920, I think it may be interesting to publish notes on the following case; though the treatment was not finally successful, yet the response was so marked as to emphasize the importance of the method.

The patient was a weak thin man of 45 to 50. On August 21st, 1920, the operation of gastro-enterostomy was being performed by Mr. F. O. Lasbrey for continual pain and vomiting. It was largely completed when the patient stopped breathing. Artificial respiration was performed and breathing very soon started again, but the pulse was very weak. The operation was continued, but in a few minutes breathing stopped again, and the pulse could not be felt. Artificial respiration, strychnine, ether under the skin, hot cloths to the epigastrium were all tried without avail. The gloved hand was inserted in the abdomen through the operation incision and an attempt made to massage the heart through the diaphragm, but the heart could not be felt at all. Finally, after half an hour, during which time there had been no voluntary breathing and no pulse or audible heart sounds, the case appeared quite hopeless. Then direct massage of the heart was tried. I cut through the anterior left fibres of the diaphragm and passed my gloved hand, by means of the abdominal incision, through into the chest cavity. I found the heart small, flabby, and empty, and quite without movement. I grasped and squeezed it, and kept up continued massage on it, artificial respiration being continued meanwhile. After some considerable time, at least five minutes, the heart began to respond, inasmuch as it became firmer and larger, and on squeezing it empty it automatically filled again. Massage was continued. Shortly after, on ceasing the massage for a brief period, a very small beat, feeling almost like a tremor, continued, but only for a very short time. Pituitrin extract, 1 c.cm., was given, and soon after, on ceasing the artificial respiration, the patient took one respiration himself,

but did not continue. Again later the heart continued to go for a brief time alone and the patient breathed again. Then he breathed twice in succession, later three times, and so on till he twice breathed automatically nine times consecutively, but did not continue. Also the heart would not keep going for long if the massage were suspended. About a pint and a half of normal saline was injected into a vein in the arm and more pituitrin extract given, but the breathing would not start again. The heart gradually got weaker. It still responded to massage, but would only give one or two beats when left alone, till finally, nearly two hours after breathing first stopped, response failed and the case was given up.

We may note that the heart had given no sign of beating for about half an hour when direct massage was tried. It could not be grasped or moved at all through the diaphragm because it was small, empty, and flabby, and lying against the back of the chest wall. Massage was continued for over an hour, and up to nearly an hour after commencing direct massage there was irregular and non-continuous automatic heart-beating and unaided respiration. This case might have been hopeful had direct massage been employed earlier. It would appear wise in every case of collapse under anaesthesia to employ cardiac massage as soon as it is ascertained that the heart has ceased to beat.

ROBERT B. COLEMAN, M.B., Ch.B. Birm.,
Church Missionary Society's Hospital,
Old Cairo, Egypt.

Reports of Societies.

SURGERY OF THE ELBOW.

AT a meeting, held on November 26th, 1920, of the Surgical Section of the Royal Academy of Medicine in Ireland, with Sir W. J. DE C. WHEELER in the chair, Mr. R. ATKINSON STONEY read a paper on modern surgery of the elbow, and showed three cases of excision of the elbow operated on from ten months to ten weeks previously for ankylosis following gunshot wound. A fourth case was shown of operation for flail elbow, also succeeding gunshot wound. In all cases the result was an arm with good movement of the elbow and fair stability. Owing to the short interval which had elapsed since some of the operations, further considerable improvement might confidently be expected. As a result of the Great War, the speaker said, the surgery of the elbow had retrogressed by forty years. Before the war an ankylosed elbow was looked upon as a success, and excision for it was banned. The change of surgical teaching was largely caused by the bad results obtained by excision of the elbow in the early stages of the war, and this again was the result of the employment by unsuitable men and in unsuitable cases of the operation of primary excision—an operation which was probably never justifiable except as a life-saving or arm-saving device employed by the inexperienced. The teaching was now becoming crystallized that excision was unsuitable for gunshot wounds of the elbow, and that the ideal result was an ankylosed joint. This it appeared was largely due to the application of the principle of reducing the standard to the lowest capacity—an attempt to make rules to fit all cases. A good elbow with free movement and moderate stability was possible of attainment in most cases of ankylosed joint, and in some cases of flail elbow. Each case of ankylosed or flail elbow should be carefully considered with regard to (1) the present condition, and the handicap caused to the patient's work; (2) the result that might be expected from operation, especially with regard to the relative movement and stability of the new joint; (3) the consequent increase in the man's capacity or usefulness at his old or some new occupation. The position should then be fairly explained to the patient, and he should be allowed to decide for or against operation.

The main points in excision were: Vertical division of the triceps and its insertion into the periosteum and deep fascia of the forearm; limited removal of bone in the forearm; careful suture of the wound in layers; drainage; early electrical treatment and massage. The main points in operating for flail elbow were: Division of tissues between bones in a vertical direction from behind until the fibres of the brachialis anticus were reached; adjustment of bone ends, which should be united, preferably by several strands of silkworm gut; suture in layers of the

tissues behind the bones; no drainage; avoidance of early weight or strain on arm.

Sir WILLIAM WHEELER said that while individual cases should be treated on their merits, it was his general practice to mobilize ankylosed elbows in officers, and in men to secure fixation at an open angle, especially in the left elbow-joint. A certain degree of lateral mobility was inevitable after resection, and, as a rule, the security of a fixed joint was better for manual work. Mr. H. STOKES spoke in favour of fixation, and described the originally desperate condition of one of Mr. Stoney's patients whom he had seen in France with streptococcal septicaemia. Mr. ADAMS A. MCCONNELL maintained that the question of fixation or mobilization should be decided by the employment which the patient wished to follow. Mr. DOOLIN referred to the dangers of lighting up latent infection in wounded joints, particularly in the case of tetanus. He had been accustomed to use the Kocher incision instead of the vertical.

Mr. STONEY, in reply, said that no rule could be framed for treating lesions of the elbow. Each case should be given the opportunity of the treatment best suited to its requirements. He had never had a case of gunshot injury where tetanus had been lighted up by operation; he used a dilute bipp as a prophylactic against latent sepsis.

PATHOLOGY OF INFLUENZA.

AT a meeting, held on December 2nd, 1920, of the Pathological Section of the Liverpool Medical Institution, the President, Dr. J. E. GEMMELL, being in the chair, Dr. J. G. ADAMI, Vice-Chancellor of Liverpool University, read a paper entitled "The pathology of influenza: an attempt to find a common lesion for the successive stages of pre-pandemic purulent bronchitis, pandemic pneumonia, and the haemorrhagic pulmonary oedema characteristic of the late pandemic of influenza, and to distinguish those lesions due to the primary causative agent from those due to the secondary invaders."

Dr. Adami first referred to the generally accepted view that the influenza epidemic started in May of 1918, and was followed by a much more serious epidemic in the autumn of that year. He did not, however, think that this view was correct, for early in 1916 and the spring of 1917 Hammond, Rolland, and Shaw had described a series of cases of purulent bronchitis in what was now known to have been the Etap'les area. These cases were characterized by a peribronchitis, a destruction of the lining bronchial epithelium, and a bronchitic and bronchiolitic purulent discharge, all of which were associated with the presence of both the influenza organism and the pneumococcus. It was curious to note that in the same year (1917) an exactly similar epidemic was noted in the Aldershot area by Abrahams. Further, in that year American bacteriologists noted a very fatal form of pneumonia following measles. MacCallum showed that the morbid anatomy of the respiratory tract was that of an interstitial pneumonia, an exudate that was not excessively cellular, a destruction of the epithelium of the bronchi, and a microscopic appearance of the bronchioles extremely suggestive of that found in the French and English epidemics. This investigator found, however, that the chief organisms in this series were a haemolytic streptococcus and the pneumococcus; the influenza organism was only noted a few times. Then came the great epidemics of 1918. Dr. Adami showed that in the reports from France, Macedonia, Italy, India, and America, it was possible to trace a morbid histology and bacteriology common to all. In all areas the disease was ushered in with congestion and inflammation of the upper nasal respiratory tract, and in those regions where those parts had been bacteriologically examined reports invariably showed that the influenza organism had been recovered. Further, a tracheitis limited to the lower third of the trachea was perhaps the greatest common histological factor. The speaker felt sure that whatever might have been the changes due to other bacteria, the influenza organism of Pfeiffer, if not the *causa causans*, was always associated with the disease. In the autumn, however, it was obvious that the virulence of the organism had been raised to an inordinate degree, and Dr. Adami suggested that the absence of pus, the haemorrhagic oedema, and the marked lymphatic dilatation

might be explained by negative chemiotaxis. In this connexion reference was made to the classical experiments of Metchnikoff on mild and virulent anthrax organisms. After demonstrating the means whereby the lungs were protected from micro-organisms by the obliquity of the nasopharynx and by the ciliated epithelium, Dr. Adami showed how in influenza this protective device broke down.

The discussion was adjourned until the next pathological meeting.

CLINICAL CARDIOLOGY.

A MEETING of the Devon and Exeter Medico-Chirurgical Society was held at the Royal Devon and Exeter Hospital on December 16th, 1920. In the absence of Mr. B. Dyball, the President, the chair was taken by Colonel RANSOM PICKARD, C.B., C.M.G.

Dr. W. GORDON read a paper on the practical gains of clinical cardiology since 1900 (printed in the BRITISH MEDICAL JOURNAL of January 1st). In the discussion which followed, Dr. B. KELLY commented upon the comparative rarity of massive oedema as a complication in cases of cardiac disease occurring in the Exeter area. He had also noted that when oedema did occur it was a late manifestation in the case, and where his experience had taught him to expect no improvement. He asked Dr. Gordon if he could give any explanation for this local variation. Dr. R. V. SOLLY, in alluding to the subject of malignant endocarditis, mentioned that short streptococci had been found in the majority of his cases, and that vaccine treatment had not so far proved to be of any benefit.

Mr. NORMAN LOCK gave an account of two cases where manipulation of the heart had been undertaken for the treatment of profound shock, and he also narrated the case of a man from whom he had removed shrapnel embedded in the anterior border of the heart. Prior to operation the man showed high grade cardiac inefficiency, but he had made a good recovery, and was now able to earn his living at a moderately light occupation. Dr. F. A. ROPER considered that "irritable heart" must not too readily be assigned to neurasthenia. As regards heart hurry he had frequently noted a high blood pressure in such cases, and he had often had reason to suspect that the condition might lead to actual arterio-sclerosis. He was of opinion that clinical instruments, such as the electro-cardiogram, although not directly concerned with treatment, were a powerful attribute to diagnosis.

Dr. J. D. HARRIS spoke of his personal experience as to the value of digitalis in two cases of auricular fibrillation. He referred also to the difference in the long axis of the heart as shown by x rays in various subjects. With regard to treatment in streptococcal infection, he discussed the possibility of x rays being able to reach the endocardium, having regard to the short distance from the surface. Dr. H. E. WHITE commented upon the irregular heart so often noted after measles in children, and he asked for an explanation of a murmur audible in the axilla but not at the apex. Dr. T. R. WHIPHAM discussed the value of the cardiogram in demonstrating myocardial changes. Mr. WAYLAND SMITH paid tribute to the benefit derived from the employment of atropine in cases of enteric fever occurring amongst the troops in France. Slow action of the heart—an early symptom—had been considered an indication for giving the drug.

Dr. G. L. THORNTON referred to the comparative decrease in the number of cases with a diagnosis of disordered action of the heart appearing before pensions boards during the past twelve months. The majority had been classified into their respective cadres, quite a large number being symptomatic or sequelae of malaria or dysentery, and responding to the treatment given for the parent disease. Others had been referred to the neurological clinics as entirely of nervous origin, whilst most conspicuous was the high figure of those who had been proved to be suffering from pulmonary tuberculosis, the dyspnoea and poor cardiac response apparently being but an early symptom of that disease. A small minority remained where the onset of the cardiac disability could be referred to strain during service.

Dr. A. HIPWELL referred to the cardiac condition found amongst cases attending the tropical diseases clinic, and

emphasized the importance of sub-classification, if the term "D.A.H." was to be used at all. Colonel RANSOM PICKARD, speaking from his experience as the A.P.M.S. of a Division, had noted the loose employment of the classification "D.A.H.," and of the amount of correction in diagnosis which had been found necessary when so-called cardiac cases were examined at medical boards.

Dr. W. GORDON, in reply, stated that in his opinion instrumental methods were impracticable for general use, and that they were of physiological rather than of clinical utility. With regard to Dr. White's question, he had frequently noted a respiratory murmur in the axilla. He had made observations similar to those of Dr. Kelly, and attributed the cause to a mild climate, which made complications such as bronchitis or nephritis less frequent. As regards treatment in malignant endocarditis, he mentioned improvement after injections of antistreptococcal serum, and more recently of esol intravenously. He hoped that the connexion between "D.A.H." and early tuberculosis would be given publicity. Referring to remarks made by Dr. Harris, he stated that the axis of the heart was daily receiving more attention. He had had no personal experience of atropine in enteric fever.

Reviews.

DR. CREIGHTON'S CONCLUSIONS ON CANCER.

IN his recent work *Some Conclusions on Cancer* Dr. CHARLES CREIGHTON brings forward the result of work, published and unpublished, extending over nearly fifty years. The problem of cancer has thus been critically studied by him for an exceptional period, and after such prolonged investigation his views demand respectful consideration, even though they may run counter to generally accepted opinion, and are not very easy to grasp. A study of chorion epithelioma, which provides special data supporting his deductions, was recently undertaken at the London Hospital, and ample opportunities for investigating mouse cancer have been utilized. The object of this volume is avowedly not controversial, critical, or negative, but to put forward positive conclusions based on original observations and argued at first hand. After an introduction, which summarizes the argument, the first part, illustrating the principles, deals at some length with chorion-epithelioma, mouse cancer, and malignant tumours of the eyeball; the second part describes cancer in its common sites—namely, the skin, the alimentary canal, breast, and uterus; the last chapter sums up the author's views on causation, and there is an interesting appendix on the history of endothelioma.

Dr. Creighton insists that cancer is not due to one cause only and that the search for a unit of causation will lead to disappointment, for in every cancer there are various co-operating factors, of which one may be predominant in one form or locality of the disease, another in a different one. He argues that the commonly accepted view that cancer is due to a continuous overgrowth of pre-existing epithelium is erroneous, and that recent investigators of chorion-epithelioma and mouse cancer have missed a great opportunity because they have been dominated by this conception. Consideration of chorion-epithelioma, mouse cancer, glioma of the retina, and melanoma of the choroid leads him to the conclusion that the blood is the important factor, but he points out that discrimination is necessary in translating the old language of cancer as a blood disease into the more exact technical terms of modern research. The blood, he holds, is implicated in various ways to the same end; in chorion-epithelioma it is acted upon by a ferment diffused from the foetal epithelial cells, and the blood thus altered provides the food for the new growth; in mouse cancer a dyscrasic state of the blood due to interbreeding is assumed, and to the two forms of intra-ocular malignant disease other explanations apply. The blood and the blood vessels are inseparable, and when in disease the cells of a part feed on the blood, the cells most concerned are in the walls and adnexa of the blood vessels. Malignancy always means that the cells of an organ or tissue take to feeding on the substance of the red blood corpuscles instead

¹ *Some Conclusions on Cancer*. By Charles Creighton, M.D. London: Williams and Norgate. 1920. (Roy. 8vo, pp. 378; 115 figures. 42s. net.)

of metabolizing it, storing it up, or passing it on; and a disproportionate nucleus is regarded as a sure index of a structure built up from ferment-reduced blood. Thus a cancer is a blood-built structure composed of blood vessels and gland tissue. The analogy with the physiological blood-built structure of the placenta, on which Dr. Creighton has written much, would be more complete if syncytium were more generally present in morbid growths than is now recognized, and this from his own observations he believes to be the case.

TEXTBOOKS OF HYGIENE.

A VOLUME consisting of over 400 pages, even dealing with so wide a subject as public health, can hardly be included among those termed cram books, and there are many other reasons why *Hygiene*,² by Dr. JAMESON and Mr. MARCHANT, should not be so categorized. The authors describe it as an attempt to epitomize the views of accepted authorities and the most recent work in the huge subject of hygiene. We may state at once that they have not been unsuccessful in that endeavour. They have produced a textbook well planned, easy of reference, and reliable. Far more than the surface of the subject has been scratched, but the student is not taken into such depths as to obscure his vision for essentials. Whatever other textbooks he may have studied, he will almost certainly find in this one either something entirely new or a specific subject put forward in a new form. The arrangement of the work follows very much on the lines of older textbooks. The earlier chapters deal with water supplies, the removal and treatment of waste matters, ventilation and heating, soils and building construction, and with food supplies. These are followed by chapters on infant mortality, child welfare, school hygiene, prevention of disease, industrial diseases, vital statistics, sanitary law, meteorology, and some notes on chemistry. The section dealing with industrial diseases, though covering only nine pages, gives evidence of much painstaking inquiry, and will be helpful for examination purposes, but it is capable of considerable extension. On page 169 reference is made to the influence upon the incidence of tuberculosis of back-to-back houses, and mention is made of the Salford investigations. There have, however, been much more recent inquiries than that at Salford, and with more convincing results. The statement on page 261 that the appointment of a medical officer of health to an urban or a rural district cannot be terminated without the consent of the Ministry of Health is not yet correct. The full title of the Order under which these officers are appointed is "The Sanitary Officers (outside London) Order, 1910." The proof reading of this work has been remarkably well done, though on page 302 the Infectious Disease Notification Act is described as the Infectious Diseases Act. Such minor slips will no doubt be remedied in the future editions which will deservedly be called for.

One of the earliest textbooks included in Lewis's Practical Series was that on *Public Health Laboratory Work*³ by Professor HENRY KENWOOD. The seventh edition is concerned only with the chemical branch of the subject. Part VII, which appeared in former editions and referred to microbiology, is omitted; the subject is to be dealt with in a separate volume from the pen of Professor Sheridan Delépine. The general arrangement of previous editions has been followed in this, the subject being dealt with under the headings of the examination of water, sewage and sewage effluents, soil, air, food and disinfectants. There is ample evidence of drastic revision of former editions, and there has been a fearless combing out of superfluous paragraphs and of matter which research in recent years has rendered out of date or unreliable. For example, in 1908 Professor Kenwood, when writing of the presence of zinc in water supplies, stated that a trace of this metal (not exceeding one-tenth of a grain to the gallon) might perhaps be allowed, but he now states that he has found up to one grain per gallon in

many waters which have been in contact with galvanized iron and used for many years in public institutions without any evidence of harm. His opinion now is that one-third of a grain per gallon should not be exceeded. It would have been helpful if the author had expressed his own opinion more freely on the question of dirt in milk. It has been suggested, he writes, that as a general rule the recoverable dirt should not be allowed to exceed two parts per 100,000 by weight. As a rough household test half a pint of milk placed in an ordinary tumbler should not throw a visible sediment in two hours. He admits, however, that, as dirt may be partially removed by trade filtration, leaving behind the harmful bacteria, the only satisfactory standards are those based upon bacterial counts. In the section on food examination he discusses at some length the question of poisoning by food. He is in agreement with present-day observers that ptomaines are not the cause of extensive outbreaks of meat poisoning, which are, he considers, commonly caused by the bacilli of the Gaertner group. The section on water examination has been subjected to most careful revision, and the concise and clearly expressed instructions for carrying out various processes have been made even more lucid and intelligible. For this reason alone, if merely as a time saver, medical officers of health and others engaged in public health laboratory work will find this book invaluable.

A MANUAL OF NEURASTHENIA.

IN A *Manual of Neurasthenia* by Dr. I. GEIKIE COBB⁴ the general practitioner will find a thoroughly helpful and comprehensive account of a disorder which bulks largely in his daily work. The book is written on sound, practical lines. The symptom-complex of neurasthenia is clearly described; the etiological factors are discussed in detail; a full account is furnished of the various mental and physical symptoms and objective signs; the treatment is indicated under the headings of general hygiene, principles and details of diet, use of drugs, climate, psychotherapy, electricity, and other special methods; and the points of differentiation between neurasthenia and conditions for which it might be mistaken are indicated in schematic form.

Dr. Cobb regards neurasthenia as a definite clinical entity. He finds (p. 205) that "the cardinal symptoms and signs are so constantly associated that they form as certain a correlate as those of any well-recognized disease. The presence of undue fatigue, typical headaches, digestive disturbances, and sensory abnormalities points to the presence of the disorder." In regard to this vexed question, it may be said that the range of cases in which neurasthenia will be regarded as an adequate diagnosis will no doubt tend increasingly to diminish. Further research will probably make it clear that many cases of nervous exhaustion are symptomatic only, and the expression of definite and specific underlying causes. Since the disorder was first described the tendency has been all in this direction. Dr. Cobb would seem to have included as much and no more in his neurasthenic group than the facts warrant in the present state of our knowledge. Since the diagnosis of neurasthenia is often made to cover almost any type of nervous illness, he has very wisely made perfectly clear and definite what he includes under the concept of neurasthenia. He excludes many symptoms which the term originally included, such as obsessions, phobias, and anxiety, but he uses it in a wider sense than Freud by including the chronic form of nervous exhaustion occurring in middle age, as well as the restricted group in which auto-eroticism is the pathogenic factor. Since he adopts this wider conception of neurasthenia, Dr. Cobb naturally finds a number of factors instrumental in its production, and he devotes considerable attention to toxic and other causes of a physical nature. A full recognition of mental factors is given, and the view is expressed and developed at length that emotional influences cannot be limited to the sexual sphere, but that other instinctive trends have to be reckoned with in the production of nervous exhaustion. While we quite agree that conflict as a factor in the production of neurasthenia is certainly not confined to the sexual impulse, yet the

² *Hygiene*. Specially adapted for those studying for a Diploma in Public Health. By W. Wilson Jameson, M.D., ABERD., M.R.C.P., D.P.H., and F. T. Marchant, M.R.San.I. London: J. and A. Churchill, 1920. (Demy 8vo, pp. 404; 18 figures. 18s. net.)

³ *Public Health Laboratory Work (Chemistry)*. By Henry R. Kenwood, C.M.G., M.B., D.P.H., F.C.S. Seventh edition. London: H. K. Lewis and Co., Ltd. 1920. (Demy 8vo, pp. 451; 4 plates, 25 figures. 15s. net.)

⁴ *A Manual of Neurasthenia (Nervous Exhaustion)*. By Ivo Geikie Cobb, M.D., M.R.C.S. London: Baillière, Tindall, and Cox. 1920. (Demy 8vo, pp. xvi+366. 12s. 6d. net.)

important fact that neurasthenia in young people is often closely related to active auto-erotic tendencies is perhaps insufficiently stressed. The term "auto-eroticism" is hardly explained sufficiently to be helpful to the practitioner. It is not made clear that this term in relation to neurasthenia refers to onanistic tendencies which lead to fatigue symptoms through excessive expenditure of nervous energy. Though the question of mental conflict is also involved, the sexual etiology in neurasthenia would seem, in a sense, to be physical in character as contrasted with the purely psychogenic origin of the symptoms in the psychoneuroses. We venture to make this comment because we think more attention to this difficult subject in the section devoted to treatment would have been of practical value to the practitioner, as it is a question he has constantly to face in dealing with his young patients.

The chapters devoted to symptomatology are particularly clear and complete, and due emphasis is laid upon diagnostic points. The treatment also is described fully, and the value and limitations of the various therapeutic agents excellently discussed. The detailed instructions herein found contrast favourably with the either too vague or too specialized methods of approach which characterize much that is written on the neuroses. In a subject such as neurasthenia, which presents peculiar difficulties and which may be investigated from so many points of view, it is inevitable, and no doubt necessary, that certain causal factors should be over-emphasized by observers with specialized interests. Dr. Cobb has managed, however, to present a broad and impartial account of the disorder. In his preface he says: "The exclusive preference shown by many . . . for the hypothesis of physical origin on the one hand or of mental on the other, has made the task of steering between the Scylla of mind and the Charybdis of body a difficult one." The task is undoubtedly difficult, but in the present instance it may be regarded as having been successfully accomplished.

NOTES ON BOOKS.

THE mere fact that a work devoted exclusively to the subject of impotence has survived five editions is—as its author points out in its preface—an indication that such a work was required. It is certainly true that the failure of sexual desire and sexual power may be the cause of a great amount of mental suffering, and that the subject is thereby endowed with considerable importance. The study of sexual impotence embraces such widely varied themes as psycho-analysis and endocrinology. Impotence may be a symptom of many different pathological conditions, and to arrive at a correct diagnosis demands considerable clinical acumen. Three-quarters of Dr. VECKI's work is devoted to a discussion of the various forms of impotence, and the final chapters deal with treatment. The great number of the methods of treatment that have been advocated by different authorities is an indication of their inefficiency. Yet, in the words of the author, "there is hardly any one of them that could be entirely dispensed with because there are cases in which one or the other may be of some use." Of the utility of retaining some of the methods described in this work we are sceptical. Even the enthusiasm of Dr. Vecki fails when describing some of the hundred and one therapeutic measures that have been advocated. For the moment the hope of the impotent would appear to be in the realm of endocrinology. In the concluding chapter is an interesting summary of present knowledge on the subject of the endocrine glands and their relation to the sexual function. The author has wisely confined himself to the task of supplying his reader with facts and has resisted the temptation to indulge in vague speculations.

A *Dictionary of Scientific Terms*⁶ by I. F. and W. D. HENDERSON, of the University of Bristol, contains about 10,000 definitions, including those of several hundred lately coined expressions, many of which have not hitherto found their way into a dictionary. In addition, it gives the pronunciation and definition of the terms used in biology, botany, zoology, anatomy, cytology, embryology, and physiology. The Greek words given in connexion

with derivations have been transliterated, because, as the preface states, students of science and medicine are considered to be seldom acquainted with that language, and the transliteration of certain combinations of letters represents the sound rather than the exact letters of the original—for example, *branchia* appears as *brangchia*, and *korymbos* as *korymbos*. A superficial examination of the work gives an impression of its utility to medical students in their early years, and of the labour and care the compilers have devoted to this well-printed work. It does not include terms used solely in clinical medicine and surgery and in pathology.

PRESENTATION TO DR. J. A. MACDONALD.

THE following further subscriptions have been received from November 29th to December 31st, 1920, in response to the appeal published in the *JOURNAL* of July 24th (p. 129), towards a presentation to Dr. J. A. Macdonald on the occasion of his retirement from the office of Chairman of Council of the British Medical Association which he had held for ten years. Subscriptions of any amount not exceeding five guineas should be made payable to "The Macdonald Presentation," and sent to the Medical Secretary, British Medical Association, 429, Strand, London, W.C.2.

ELEVENTH LIST OF SUBSCRIBERS.

	£	s.	d.		£	s.	d.
Brought forward from last list of subscribers	783	0	6	O'Dowd, Dr. J. A., Netherton	1	1	0
Auck and (New Zealand) Division, per Dr. W. A. Fairclough	4	4	0	Plant, Dr. H. W., Penzance	1	1	0
Birkbeck, Dr. L. H. C., Taunton	1	1	0	Smith, Dr. F. M., Quarry Bank	2	2	0
Brook Mr. W. F., Swansea	1	1	0	Smith, Dr. H., Dudley	1	1	0
German, Dr. A. W., Liverpool	1	1	0	Watkins, Dr. B. V., Clent	1	1	0
Hinnell, Dr. J. S., O.B.E., Bury St. Edmunds	1	1	0	Per Dr. C. L. Hawkins (Honorary Secretary, Bromsgrove Division)			
McNider, Dr. J., Hull	2	2	0	Ambrose, Dr. W. C., Barnt Green	0	10	6
Robinson, Dr. E. S., Stourport	0	10	6	Ianks, Dr. R. McL., Redditch	0	10	6
Tireman, Dr. A. L., Hull	2	2	0	Rodger, Dr. S., Studley	0	10	6
Wiggins, Dr. C. A., Uganda	1	1	0	Coaker, Mr. F. W. J., Bromsgrove	0	10	6
Per Dr. J. MacNider (Honorary Secretary, L. York Division):				Collier, Dr. H. L., Redditch	0	10	6
Lilley, Dr. G., Hull	1	1	0	Dick, Dr. M. L., Alvechurch	0	10	6
Rodger, Dr. T. R., Hull	2	2	0	Hawkins, Dr. C. L., Barnt Green	0	10	6
Stewart, Dr. F. N., Hull	0	10	6	Rae, Dr. A. J., Bromsgrove	0	10	6
Sunderland, Dr. K. A. S., Hull	1	1	0	Smith, Dr. P., Redditch	0	10	6
Upeott, Mr. H., Hull	1	1	0	Stevenson, Dr. J., Redditch	0	10	6
Wilson, Dr. Albert, Hull	0	10	6	Per Dr. Moyes (Honorary Secretary, N. Northumberland Division):			
Per Dr. Taylor (Honorary Secretary, Dudley Division):				Badcock, Dr. A. E., Cernbill-on-Tweed	1	1	0
Beasley, Dr. J. G., Rowley Regis	1	1	0	Lawrie, Dr. F. W. K., M.C., Alwicks	0	10	6
Beasley, Dr. J. H., Blackheath	1	1	0	Macaskie, Dr., Bambergh	0	10	6
Dudley, Dr. G. J., O.B.E., Stourbridge	1	1	0	McDonald, Dr. J., Belford	1	0	0
Francis, Dr. L., Stourbridge	1	1	0	Per Dr. Rollason (Honorary Secretary, Coventry Division):			
Frer, Dr. W. L., Blackheath	1	1	0	MacQuaide, Dr. H. C., Coventry	1	1	0
Giffith, Dr. R. E., Netherton	1	1	0	Rohasin, Dr. N. J. L., Coventry	1	1	0
Grind'ay, Dr. G., Stourbridge	1	1	0	Snell, Dr. E. H., Coventry	1	1	0
Hardwicke, Dr. L. W., Lye	1	1	0	Mason, Dr. P. J., Great Bridge	1	1	0
Higgs, Dr. T. F., Dudley	1	1	0				
MacQueen, Dr. A. D., Blackheath	1	1	0				
Mason, Dr. P. J., Great Bridge	1	1	0				
							4832 15 6

OWING to the rise in the cost of printing and paper the subscription to the *Nederlandsch Tijdschrift voor Geneeskunde* for 1921 has been raised from Fl. 18 to Fl. 25.50.

PROFESSOR OTTO LANZ of Amsterdam, a native of Switzerland, has resigned his membership of the Société Internationale de Chirurgie as a protest against the exclusion of the surgeons of Central Europe.

DR. CARLIEB, professor of clinical urology in Lille University and an authority on diseases of the prostate, has recently died.

In the various German universities 85,000 students were enrolled last summer as, compared with 55,000 in 1914. Of the total number 18,319 were medical students and 4,723 dental students, as compared with 16,048 and 976 respectively in 1914.

A SOCIETY entitled "Société Bruxelloise de laryngologie" has recently been formed at Brussels. Its meetings will be held monthly.

⁵ *Sexual Impotence*. By V. G. Vecki, M.D. Sixth edition, revised. Philadelphia and London: W. B. Saunders Co. 1920. (Demy 8vo, pp. 232, 16s. net.)

⁶ *A Dictionary of Scientific Terms*. By I. F. Henderson, M.A., and W. D. S. Henderson, M.A., B.Sc., Ph.D., F.R.S.E., Edinburgh: Oliver and Boyd, 1920. (Demy 8vo, pp. 360, 18s. net.)

REFORM IN MEDICAL EDUCATION.

[FROM A CORRESPONDENT.]

(Continued from page 22.)

I.

REVISION OF THE MEDICAL CURRICULUM.

THE replies from the schools as to education in preventive medicine seem to have had a great effect on the outlook of the Education Committee and the General Medical Council, for in a full report to the Council at the May session of 1920 it urged that the numerous considerations and recommendations submitted by the schools raised the whole question of revision of the medical curriculum apart from, and in addition to, the teaching of preventive medicine. This view was strengthened by the publication of Sir George Newman's "Notes on Medical Education in England," and the Edinburgh Pathological Club's "Enquiry into the Medical Curriculum."

It may be noted that the replies from the schools were in general very sympathetic in respect to the query by the Council concerning "teaching regarding the maintenance of health from birth onwards." It appears, indeed, that the organizations for child welfare developing all over the country are being in many cases linked up with the medical schools for the purpose of teaching to students the prevention of disease from infancy onwards. The Middlesex Hospital School writes that "in the case of diet and childhood considerable instruction is given in connexion with the infant welfare department, but we are fully alive to the fact that instruction on the prevention and arrest of disease might be amplified with considerable advantage." The University of Edinburgh replies that "opportunity for the study of infant nutrition and dietetics is furnished also by the Municipal Scheme of Child Welfare, and the students who attend are trained in the administration of the preventive clinics." University College Hospital School "wish to call attention to the fact that at this hospital there is a well-equipped maternity and child welfare centre in which the feeding and the health of infants and children is taught to the students." In connexion with St. Mary's Hospital School, the Paddington Green Children's Hospital "secures that the student shall have special instruction in children's diseases, including, of course, the diet of infancy." At the University of Leeds "the formation of a special children's department at the General Infirmary, including a section for the nutritional diseases of infants, has recently been decided on. The honorary officer in charge of the department will give a course of instruction in the hygiene and diseases of infancy and childhood, infant feeding, etc. It is also proposed to link up the infant welfare work in the city of Leeds with that of the new department." The Council's inquiries on this subject of preservation of the health of infants and children are fortunate, therefore, in coinciding with the establishment of facilities for the giving of the desired instruction. Many other passages in the replies from the schools point in the same direction.

As regards preliminary education in general knowledge it was the view of the Committee that "much advantage would be gained were the minimum age at entrance raised to 18." Concerning the earlier sciences it was urged that "the first duty of the teacher is to teach his own subject as a science" and that he should not be called on to include in his syllabus any material which can be better taught at a later stage of the curriculum. The importance of the study of embryology was insisted on in connexion with the teaching of anatomy, but, on the other hand, it was thought that the student should be spared much of the vast accumulation of minute details with which his textbooks are loaded. As to pathology and bacteriology the Committee quote Sir George Newman, who wrote: "The fact is that, broadly speaking, pathology is medicine; it is the study of disease; it is the first great clinical subject of the curriculum." About normal psychology, of fourteen bodies who have given attention to the interrogation in the circular letter, the majority hold that some instruction should be given by the lecturer in mental diseases, but few regard the subject as falling within the domain of physiology.

These are samples of observations and suggestions. Space forbids further illustrations, but, as pointed out in the report, very especial emphasis was given in many

replies to the question of proper co-ordination of studies. Preventive medicine must largely be in the hands of the clinicians, and an extension of the period of clinical study would, of course, mean a lengthening of the curriculum, though "a block introduced into the course by making provision that the examinations in pharmacology and pathology must be completed before the commencement of the recognized fourth year, could it be made effective, would at least ensure two full years for undivided clinical study"; but that proposal "might have to be accompanied by a diminution and simplification of the teaching demands" of the earlier subjects.

At the end of a full and most thoughtful report the Education Committee, as already indicated, felt compelled to make the following recommendation to the Council:

"The Committee begs to submit to the Council the foregoing report on 'The teaching of the preventive aspects of medicine,' which has been prepared by the Chairman after an analysis of the replies received from the teaching bodies. The Committee is of opinion that the questions which have been raised involve the revision of the whole curriculum in medicine, and suggests that the Council should remit to it for further report the consideration of the methods under which the process of revision may best be carried out."

The Committee's suggestion was accepted by the Council, and the outcome was embodied in a further report which was discussed by the Council at its recent session. This report concluded with three recommendations, which were dealt with separately.

Recommendation I.—Preliminary Sciences.

This recommendation included the four following items:

"(a) That before registration in the *Students' Register* every applicant shall be required to have passed, in addition to the examination in general education, an examination in elementary physics and elementary chemistry conducted or recognized by one of the licensing bodies;

"(b) That a student who has diligently attended an approved course of instruction in elementary biology in a secondary school or other teaching institution recognized by a licensing body may be admitted to a professional examination in elementary biology immediately after his registration as a student of medicine;

"(c) That before registration as a student every candidate shall produce evidence that he has attained the age of 17 years;

"(d) That specialized instruction in physics, chemistry, and biology, in their application to medicine shall be included in the professional curriculum, the teaching arrangements in each case to be determined by the licensing body."

These are mainly self-explanatory. It is desired that, in addition to his examination in general education, the student shall have received instruction and passed an examination in elementary physics and chemistry. By this transference from professional to preliminary study the medical curriculum proper will be correspondingly lengthened, and it is regarded as certain that sufficient instruction in these subjects can be obtained at many of the secondary schools at least in England and Scotland, though in respect of Ireland the position is not so satisfactory. During the discussion in the Council an amendment was moved that biology, instead of being dealt with under (b) in the above recommendation, should be included with (a). This amendment was not carried, and the Education Committee's reason for proposing that there should be a difference was that not nearly so many schools have facilities for instruction in biology as in physics and chemistry. The proposal of the Committee to get over this difficulty as contained in (b) is ingenious—namely, that students who have at secondary schools acquired a sufficient knowledge of elementary biology can proceed to a professional examination in the subject immediately after registration, so that, in effect, all three elementary subjects will in such cases have been cleared out of the way before other studies are entered on. If, however, students have not had the facilities for instruction and examination in one or more of the three preliminary subjects, they can come to the medical schools for tuition, but they cannot be registered until the examinations in physics and chemistry have been passed. This would probably meet the difficulties in Ireland above referred to. Section (c) of the first recommendation—namely, that a student must have reached the age of 17 years, instead of 16 years as at present, was a natural corollary to (a) and (b).

Subsection (d) of the first recommendation—namely, that specialized instruction in physics, chemistry, and

biology, in their application to medicine shall be included in the professional curriculum—indicates one of the lines of reform which were under discussion by the Education Committee and the Council. These three elementary sciences in their direct application to the later parts of the curriculum, and especially to the clinical subjects, should be taught in connexion with such later subjects, whether as part of the particular course of instruction by the teachers of the clinical subjects, or in a short series of lectures or course of instruction in applied physics, chemistry, etc., the details being left to each individual school.

Recommendation III.—Subcommittees on Curricula.

Passing by Recommendation II for the moment. Recommendation III has now to be referred to. It is as follows:

"That the Council approve the appointment of a number of special subcommittees, as detailed below, 'mixed' in constitution, and each containing representatives of clinical studies, to be charged with the duty of reporting to the Council on the nature of the several curricula, defining essential contents from the standpoint of the adequate training of the general practitioner; of advising as to the proper coordination of the work of instruction; and of making recommendations concerning the effective teaching of the preventive aspects of medicine:

1. The preliminary sciences, as related to medicine.
2. Anatomy and physiology.
3. Pathology and pharmacology.
4. Medicine, surgery, and midwifery."

In that connexion, an amendment in regard to Recommendation I was proposed in the discussion at the Council. The amendment was that a decision as to (a), (b), and (d) of Recommendation I should be deferred until the proposed subcommittee on the preliminary sciences had reported. The voting was equal and the amendment was not carried.

Another amendment raised the question whether the preliminary examination in science should be imposed before the present standard of matriculation examinations is raised.

The importance of this point was admitted, and by general agreement an addition was made to Recommendation I as follows:

"That the minimum standard of general education required by the Council for registration as a student should be raised to a standard equivalent to that demanded in other learned professions previously to, or concurrently with, the coming into operation of the requirement of a preliminary examination in science before registration."

Recommendation II.—Professional Examinations.

Recommendation II, which raises a fresh and most important question, may now be referred to. It has long been recognized that in the study of medicine for degree or licence, examinations have had far too much influence on the work of both teacher and student. Under the present system the student's primary object necessarily is to pass his examinations and obtain his legal qualification to practise medicine. He hopes and assumes that in reaching the desired goal he has also acquired a real knowledge of medicine fitting him for practice, but the knowledge is more or less incidental to the work of getting up the subject in such a fashion as will enable him to obtain his diploma. Examinations are indeed a continual nightmare to the ordinary student. Similarly, the teacher, especially if he does not examine his own pupils, feels it his duty to endeavour to secure that his students shall pass their examination in his subject, and is bound to work to that end. The General Medical Council has been so impressed with the undue influence which the examination system exerts on teaching and study that it now proposes to make it possible to give some weight to the student's record of work done in the course of his curriculum. Recommendation II is as follows:

"That in the regulations for the several examinations it shall be provided that the examiners be empowered, in assessing marks, to take into account the duly attested records of the work done by the candidates throughout the course of study in the subject of the examination."

There is no proposal that examinations be done away with, or that the granting of a right to practise should depend on the opinions and reports of the teachers regarding the student's career, but there is at least in this recommendation the element of recognition of the value of

the work done by the candidate during his five or six years of medical study. It seems altogether right that this new factor should be introduced, but it will require to be carefully safeguarded against abuse. When a teacher takes part in the examination of his own pupils, some small element of prejudice for or against an examinee may perhaps inadvertently have crept into the professorial mind owing to demeanour in class or other such cause. Any feeling of this sort may no doubt have some effect under the present system, but there might be more opportunity for its influence if the teacher's record of his student's work were also to count in the decision. On the other hand, where teachers expect to have no direct share in the passing or rejection of their students at professional examinations, there might be some risk of different standards by different teachers in making their records of class work. These are considerations to be borne in mind in working out a scheme, but by no means reasons for rejecting the proposal. In many cases, of course, there is no doubt at the end of the oral and practical examination that the candidate should pass, whilst in many other cases there is no doubt that he should be rejected; but in a doubtful or borderland case a fair and impartial record of a student's work might often turn the scale. One student may be nervous and hesitating under examination, and yet may have done excellent work throughout his curriculum; his record should help to pass him. Another may be glib and skilful in making a parade of knowledge with very little reality behind it; his record should help to reject him. If effect be given in the schools to the new scheme thus proposed by the Council—and it is to be observed that the question whether note of the record should or should not be taken is to be left to the discretion of the examiners—it will be watched with interest and with a hope for good results by all who have the improvement of medical education at heart.

(To be continued.)

THE HEALTH OFFICE OF THE LEAGUE OF NATIONS.

IN a leading article, entitled Health and the League of Nations, on September 11th, 1920, an outline was given of a scheme for an International Health Bureau under the League of Nations. The scheme was drafted by the International Health Conference convened by Dr. Addison last April, and was adopted subsequently by the Council of the League. The proposal has since been submitted to and approved by the first assembly of the League of Nations held on December 10th at Geneva, and it is now possible to fill in some of the details. It is proposed that the Office International d'Hygiène Publique should remain in Paris to form the basis of an International Health Organization. The office was founded in accordance with the international agreement reached at Rome on December 9th, 1910, to which all the principal countries, with the exception of Germany and Austria-Hungary, subscribed. The new organization will advise the League of Nations on all questions arising out of Articles 23 (f) and 25 of the Covenant of the League. Those in control of the International Office of Public Health are said not only to consent to this arrangement, but also to desire and welcome it. The permanent International Health Organization will consist of (a) the International Office of Public Hygiene, which, completed in a certain way, will become the General Committee, (b) a technical or executive committee, and (c) an International Health Secretariat. The General Committee will be composed of the delegates actually nominated to the International Office of Public Health according to the Rome Convention of 1907, of those subsequently appointed by the countries which were parties to the Convention, and of those nominated by countries not parties to the Convention but members of the League of Nations.

The functions of the health organization will be as stated in our issue of September 11th, namely, (1) to advise the League on matters of health; (2) to establish closer relations between the health services of different countries; (3) to organize more rapid interchange of information when it is necessary to take immediate precautions against disease (such as epidemics) and to

simplify rapid action where such information affects several countries; (4) to initiate or revise international agreements for administrative action in health matters, and especially to examine the questions to be submitted to the permanent and general committees with a view to international conventions; (5) to co-operate mutually with the International Labour Organization for the protection of workers against industrial diseases and injuries; (6) to co-operate with the League of Red Cross Societies and similar bodies, in accordance with Article 25 of the Covenant of the League; (7) to give advice on international questions of health to other voluntary organizations; (8) to organize health commissions when requested.

The General Committee is to meet at least once a year in Paris, and the Council of the League has power to call an extraordinary meeting if necessary. The General Committee may appoint subcommittees to study special questions. Any delegate may employ technical advisers, but such advisers will not have the right to vote.

The Technical Committee will consist of four members from the delegates of the States permanently represented on the Council of the League, five other members chosen by the General Committee with due consideration of scientific value and geographical representation, the President of the General Committee, a representative of the League of Red Cross Societies, and a representative nominated by the International Labour Organization. The Technical Committee will meet at least four times a year, and can be called more often in the event of urgency. It can form subcommittees, and call upon technical advisers in special questions. Its deliberations and those of its subcommittees will be submitted to the General Committee and to the Secretary-General of the League of Nations through the Medical Secretary. The President and members of the Technical Committee will be chosen for three years, but will be eligible for re-election.

The Secretariat will consist of a Technical Secretary and staff. The Technical Secretary will be nominated by the Committee in agreement with the Secretary-General of the League. He will have the right to communicate directly with the Secretary-General and with the health services of all the Governments, and to attend all meetings of the Technical Committee, of the General Committee, and of all subcommittees. The staff will consist of persons of different nationalities, nominated by the Technical Committee in consultation with the technical secretary. The location of the International Secretariat of Health will apparently be the same as that of the League of Nations.

The object of all this machinery appears to be to elaborate new international agreements and to revise agreements already existing. Such new projects or revisions will be submitted by the Technical Committee for examination and approval by the General Committee; for the adoption of the agreement a two-thirds majority of the General Committee will be necessary. When any proposed agreement affects international commerce or communication the Committee must confer with the Economic Organization and with the Organization of Communication and Transport. If the General Committee approves the projected agreement it will be signed by the President and by the Technical Secretary, and handed to the Secretary-General of the League. The Council of the League will then submit the proposed agreement to the Governments interested, which will be invited to instruct their plenipotentiaries to sign the agreement without delay. Each country will be asked to ratify such agreement before the expiration of one year, or before the expiration of that period to notify the Secretary-General of the reason why it has not done so. Each agreement ratified will be registered by the Secretary-General, but it will be binding only on the countries which have ratified it. The members of the General Committee undertake to present annual or special reports on the measures taken in each country to carry out the clauses of the agreement. Non-signatory countries will be invited to furnish reports on matters bearing on the objects of the agreement.

It is evident that the proposed International Health Organization is grandiose in nature, and under certain conditions may have far-reaching results. But it often happens that councils, such as that of the League of Nations, having set up a vast machinery of committees and subcommittees, break up with a feeling that they have accomplished a great work; whereas they have not dealt with the vital factor in the situation. If the International

Health Organization is to be anything more than a method for dealing with unemployment amongst officials, the really important matter is the appointment of the superman who is to be the Technical Secretary. On him will depend the success or failure of the whole organization. In the first place, the secretary must be a medical man of wide outlook and extensive knowledge, not necessarily an expert in any one branch of medicine. Secondly, he must have administrative capacity. Thirdly, he should speak two or three languages in addition to his own. Fourthly, he should have the power of choosing suitable people to fill gaps in his own knowledge or capacity. Lastly, he must possess infinite tact in dealing with governments and with various organizations, many of which will be jealous of their prestige and position. With energy and enthusiasm such a man might make much of the International Health Organization, notwithstanding all its complicated machinery of offices, councils, committees, and subcommittees. Without such a man it will be but a meagre feast to which the General Committee at its annual meeting and the Technical Committee at its quarterly meetings will sit down. It will be interesting to see which nation will produce this prodigy. He may become Registrar-General for the World, surveying mankind from China to Peru.

CUMBERLAND TUBERCULOSIS COLONY.

As the Cumberland Council was the first in the field in establishing an experimental farm, it is now one of the first councils in England—if not the first—to establish a colony for the industrial treatment of tuberculosis as a charge on the public funds. Dr. Morison, the medical officer of health for the county, first suggested the scheme in 1914, but the outbreak of the war prevented any steps being taken. In September, 1919, however, the Council purchased the Englethwaite Hall Estate at a cost of £5,000. The estate consists of a mansion house, a small residence, a cottage, outbuildings, a range of glass-houses, and about 32 acres of land. Its situation is in many respects ideal. It stands on rising ground, with an easy gradient on gravel soil, and has a southern aspect. It is in a sparsely populated district, the nearest village being three-quarters of a mile distant, and it is within three minutes' walk of a station on the Midland Railway, and about six miles from Carlisle.

The necessity for such an institution is apparent. Consumption is still a vital problem, and it is estimated that since 1914 there has been an increase of 12 per cent. in the death roll from tuberculosis in the country. In Cumberland 2,675 cases in all have been notified since 1912, while the number of deaths in the county during the last six years has totalled 1,461. There is in the county a sanatorium with sixty-four beds for cases of tuberculosis, but, as stated in a leading article in the *JOURNAL* for December 4th, 1920, the results of open-air or sanatorium treatment "have admittedly been disappointing, and this experience has not been peculiar to this country; nowhere have the first hopes been realized." The enthusiasm with which the colony treatment of tuberculosis has been taken up points strongly to the fact that the sanatorium treatment is not a final solution of the problem, and this new experiment will be watched with interest. The first colony of the kind was started near Edinburgh in 1910, and at the present time several English county councils have schemes in progress for the establishment of tuberculosis colonies; while, of course, the Papworth colony, as is well known, is interested in the subject.

Although there has been no formal opening there are already twenty-five inmates in residence at Englethwaite, and, with the approval of the council, plans have been submitted to the Ministry of Health which will increase the accommodation to 100 patients. In the first instance it is intended that preference shall be given to ex-service men. During the period of reconstruction and adaptation of the premises to the present purpose Dr. Kenneth Fraser has taken charge, and he has devoted himself whole-heartedly to the work. He has had the advantage of the advice and help of Dr. Morison, an official with progressive views and expert knowledge, and has been well backed up by an enlightened and sympathetic Hospital Committee. On the invitation of this committee representatives of the press in the county have recently visited

the colony and the public have been made acquainted with full details of what has already been accomplished.

Dr. Mark Fraser, a brother of Dr. Kenneth Fraser, has been appointed resident medical superintendent, and has taken up his residence in the smaller detached house in the grounds, and already a beginning has been made with several industrial occupations. A market garden of about eight acres has been started, while poultry keeping with the intention of going in for egg production on an extensive scale has been commenced. Some hundreds of day-old chicks have been bought from strains of high-laying records. For the present year only the rearing of some hundreds of Game Cross Orpingtons and other varieties for sale for table use is being developed, in order that some capital outlay may be written off within twelve months, and it is also intended to fatten geese and ducklings for the market. A start has been made with a joinery department, and a cabinet-making department will be run in combination. Some six shelters of an excellent model have been purchased from the Papworth colony, and one or two huts, one semi-intensive poultry house, and one breeding pen have been bought. These have been erected by the patients, and it is intended that all future constructional work will be done by the colonists themselves. Some military huts have been purchased and converted into workshops. Here boot and shoe repairing departments have been organized, and clog making has been started. Pig keeping is another industry which is contemplated.

The workshops are being run on strictly commercial lines, and the whole of the profits, after allowing a bonus for the men, will go to a fund for the benefit of the patients themselves, in the way of providing clothing and all the things which come under the heading of "after-care." There will be plenty of work for every inmate. Each case is being carefully studied as to his future occupational outlook. The miner can forsake his trade and become a market gardener; the barber can become a carpenter. It has not been found that men have any hesitation in so drastically reconstructing their lives or that the results are disappointing. Certain trades will be taught in combination. Each patient in training for market gardening, poultry keeping, and pig keeping will receive at least three months' training in each, so that on his discharge he may be fit to take up a small holding.

Even after discharge the medical superintendent will keep the men under supervision, and if any show signs of a return of the disease arrangements will be made to take them back to the colony. It is hoped, of course, after discharge that the men will be able to earn their own living at the trades which they have been taught, but it is considered that no colony scheme will be complete which does not provide housing accommodation for the colonists who, after the completion of their training, desire to remain on the colony. This means village settlements for tuberculous patients.

These village settlements will amount to the segregation of tuberculous patients from the general community, and should be an important factor in the stamping out of tuberculosis. Although for the time being these have been turned down on grounds of national finance, the question is bound to be reconsidered at an early date, because on the successful solution of the problems of "after-care" of which these settlements must form an important part, the whole future of the colony idea depends. Meanwhile at Englethwaite the outlook is promising. The equipment has been carefully selected, and is of the best quality, and the general arrangements have met with the cordial approval of the representatives of the press of the county.

ASSOCIATION OF CERTIFYING FACTORY SURGEONS.

The annual meeting and dinner of the Association of Certifying Factory Surgeons were held at the Queen's Hotel, Manchester, on December 15th, 1920, under the presidency of Sir Thomas Flitcroft. The regular business of the meeting included the election of officers for the coming year. Sir Thomas Flitcroft, Dr. W. F. Dearden, and Dr. T. Watts being re-elected to the offices of president, honorary secretary, and honorary treasurer respectively. The auditors' report showed the financial position of the association to be highly satisfactory.

The report of the council, in dealing with the decline in membership during the war, urged upon members the necessity for assisting the efforts of the secretaries by

personal canvass of non-members or by at least sending in their names. Particular interest was taken in the section of the report dealing with correspondence between the association and the chief inspector respecting increase of fees. Considerable dissatisfaction was expressed at the ineffectiveness of the two orders issued by the Secretary of State concerning fees for certifying and for examinations under special rules and regulations respectively. The report pointed out the ambiguity of the two scales now in vogue. It showed that they might be interpreted, as had been the case with some certifying surgeons, to mean that the surgeon is entitled to the half-crown for the visit independently of the shilling for each examination, which, if officially accepted, would undoubtedly have brought about increased remuneration for all examinations. Unfortunately, the departmental interpretation had proved to be that the half-crown still occupied its time-worn position as a covering fee, the only difference being that it now covers the visit and two examinations instead of the visit and five examinations. Compiled as the result of an inquiry, figures were presented which showed that the scale for certifying could not produce any advance in payment for 53 per cent. of the visits now made, owing to the small numbers presented on each occasion, this again indicating positively the futility of raising the basic examination fee without altering the covering fee for the visit. The chief inspector had stated, in a letter dated June 28th, that the Orders had increased the fees 100 per cent., but obviously this could only happen in the rare instances when five or more are to be dealt with at one visit.

It was unanimously agreed that the council should communicate further with the chief inspector, pointing out the views of the association and the firm conviction of the meeting regarding the necessity for rendering the 100 per cent. advance effective for all visits by making the covering fee 5s. instead of 2s. 6d. It was further agreed that the attention of the chief inspector should be directed to the circumstance that the Government is still paying the ancient fee of 3s. for two visits, two inquiries, and one report on each case of industrial disease or poisoning, with a suggestion that the minimum should now be not less than 7s. 6d.; also that all mileage rates should be the same—namely, 1s. for each mile or a portion beyond the initial mile.

ROYAL MEDICAL BENEVOLENT FUND.

At the last meeting of the Committee, held on December 14th, 1920, thirty cases were considered and £315 voted to twenty-five applicants. The following is a summary of some of the cases relieved:

Daughter, aged 61, of M.R.C.S.Eng. who died in 1885. She and her mother, who died in 1906, were left with very limited means. The applicant now has only £1 per week, and, owing to ill health and increased cost of living, finds it impossible to pay her way, and has got into debt. Voted £12 in twelve instalments and a special grant of £9 towards debts.

Widow, aged 71, of M.D.Glasg. who died in 1839. Lives with a sister who has £10 and applicant has £50. They endeavour to supplement this by letting rooms, and last year received from this source £55. Rent £34. Voted £12 in twelve instalments.

Widow, aged 75, of M.R.C.S.Eng. who died in 1883. Applicant was 1 ft. totally unprovided for with four children, all of whom are now married but are unable to assist her. Her only income is the old age pension (10s. a week) and occasional gifts from friends. Pays 6s. per week for one room. Relatives who in the past helped are now all dead. Voted £18 in twelve instalments.

Widow, aged 31, of M.B.Edin. who had for two years worked on a pensions board and previously worked as a locum net and died in 1920. Applicant left quite unprovided for with two children, aged 4 and 5. Deceased's colleagues on the pensions board collected a sum of money to assist applicant, but this will soon be exhausted. Having to look after the children she cannot undertake a post. Would like to get the children into a home. Expenses: Rent £1 a week, board 12s. a week, storage of furniture 6s. Voted £12 in twelve instalments.

Subscriptions may be sent to the Honorary Treasurer, Sir Charters J. Symonds, C.B., F.R.C.S., at 11, Chandos Street, Cavendish Square, London, W.1.

The Royal Medical Benevolent Fund Guild is overwhelmed, in these days of exorbitant prices for clothing and household necessaries, with applications for coats and skirts for ladies and girls holding secretarial posts, and suits for working boys. The Guild appeals for second-hand clothes and household articles for the benefit of the widows and children who in happier times would not have needed assistance. The gifts should be sent to the Secretary of the Guild, 43, Bolsover Street, W.1.

British Medical Journal.

SATURDAY, JANUARY 8TH, 1921.

WHITLEY COUNCILS.

AMONGST the experiments in organization which we owe to the reconstruction period, few are of greater interest than the Joint Standing Industrial Councils, for which, as chairman of the Reconstruction Committee, the Deputy Speaker, Mr. J. H. Whitley, stood sponsor in 1917. Although the point of contact between the medical profession and the Whitley system may not be obvious at the first glance, it is not in reality far to seek. Apart from the fact that the substantial success of the experiment would profoundly modify the whole organization of industry, and would thus affect the conditions of life of every class in the community, the system is not applicable to industrial workers only; it has, in fact, been applied to the case of elementary and secondary teachers in the service of local education authorities. This being so, we cannot afford to overlook the possibility that the new machinery may be applicable, with or without modification, to the special problems of certain groups of medical practitioners. New circumstances often call for new expedients, and every fresh phase of organization merits careful scrutiny as a preliminary to either acceptance or rejection.

If neither of these arguments is calculated to break through the indifference of the average man to the method by which the tangible benefits he looks for from professional organization are obtained, there remains one of potent appeal. The graduated Civil Service bonus, with its sliding scale, has doubtless, during a period of rising prices, been his ideal standard for post-war remuneration. That bonus was the fruit of the deliberations of a subcommittee of the Civil Service National Joint Council, and the method of its achievement is worthy of consideration. Finally, whether for good or for ill, at least two National Whitley Councils at present exercise a determining influence on some of the conditions of employment of several thousand medical practitioners. That, however, is a position which demands more detailed study than the limits of this sketch will permit, but in face of these facts no apology need be made for focussing medical attention upon the principles and practice of Whitleyism at the present time.

The idea underlying the Whitley experiment is that there exists a substantial community of interest between the employers and the workers in any given industry or service. On this basis the procedure hitherto applied to the settlement of disputes by conciliation boards composed of representatives of the parties concerned may be utilized for their prevention. To accomplish this goodwill on each side is needed, and a continuous joint review by the parties concerned of the conditions from which disputes commonly arise. The sphere of the joint council thus conceived embraces the whole field of conditions of employment and remuneration. It is positive as well as negative, for the point at which prevention of

disputes passes into the promotion of better conditions is hardly determinable.

The machinery proposed is a committee consisting of an equal number of representatives of the employers and the employed in each industry or service, exercising continuous supervision over conditions of employment, and acting as the accredited organ for communicating the wishes of the industry to the government and the public. A complete Whitley system for an industry involves the coexistence in each case of at least two and probably three types of joint council—the national, the district, and the works. In order to ensure adequate consideration of the needs of special grades and groups, the councils can work through special or grade committees, the members of which need not necessarily be members of the councils concerned. Although an impression to the contrary exists in some quarters, the adoption of the system is purely voluntary. Moreover, since only those reports may be issued to which a majority on both sides of the Council have agreed there is no fear of compulsion within the Council itself. In the absence of special business, the National Council is bound to meet at stated intervals to review the general situation.

Turning from the general principles to the practice of Whitleyism, we find in existence between sixty and seventy National Councils, and more than two hundred district and departmental councils. A few of these are in suspense, owing to the failure to secure a basis of agreement, or to the refusal of the parties concerned to put the agreement reached into effect. The majority of these Councils are of the orthodox industrial type, but, as already indicated, three cover various professional and administrative workers, and of these two—the Civil Service Administrative Clerical and Legal Departments Joint Council, and the Municipal, Clerical, Technical, and Administrative Services Joint Council—cover an appreciable number of medical practitioners. The third is the modified Whitley Council for Teachers, known as the Burnham Committee.

The record of these three councils includes the substitution of order for chaos in the grading and remuneration of the teaching staffs of local education authorities, the report under which the reconstruction of the Civil Service is now in progress, the report on the cost of living already mentioned, and the adoption of a scale of salaries and a grading scheme for the clerical and administrative workers in the municipal services. Here, it is true, some difficulty has arisen in the execution of the scheme. It is, however, too early to say whether the difficulties of the case will prove insuperable. This record is in itself sufficiently striking to call for a more detailed consideration of the method by which it has been produced. Meanwhile no verdict can be passed upon a system which is obviously in its infancy. All that has been attempted here is to record in outline the successive stages of its development, so that the reader who has not hitherto given attention to the system may be able to appreciate the conditions determining failure or success.

WHAT WE CANNOT AFFORD.

Those who recollect the exhortations to the Minister of Health to mobilize research armies for the "conquest" of zymotic diseases, which emanated little more than a year ago from precisely the organs which in the last weeks have held the extravagance of the Ministry up to public execration, will probably see in

the incident only another example of the frivolity or tendentiousness which are thought to characterize popular journalism. We believe, however, that the true explanation is less simple, and that it will be instructive to show that the optimism of 1919 and the pessimism of 1920 are the necessary consequences of an ignorance which it is the duty of our profession to try to dispel.

The fundamental distinction between the master of any intellectual discipline and the tyro is that the former sees his subject as a continuous whole, while to the latter it is a mass of disconnected ingenuities. Anyone may convince himself of this truth by, for instance, comparing the way in which a trained mathematician solves elementary problems with the procedure of an equally able but untrained worker; in the one case there is a certain uniformity about the methods of attack—the several solutions have a family resemblance; in the other each problem is special—a law to itself.

The application of this train of thought to medical science is direct. In the beginning man was a strict realist; there was "health" and there was "disease," or rather "diseases": disease was something which attacked man, and the problem was to drive this something out or to keep it away. Thus the first doctor was the witch doctor. An attempt to break down primitive realism and exorcise the exorciser, the witch doctor, was made by Hippocrates, who taught that disease was not a thing but a process, and his system, as Sydenham wrote, "exhibited justly such operations of Nature as she puts forth in the diseases of humanity. The vain efforts of a wild fancy, the dreams of the sick man, it did not exhibit." The degenerate Greek science of the Empire reincarnated the witch doctor; for this Galen's realism and its pre-renaissance exponents are responsible. Medical research since Harvey has progressed in such a way that no intelligent medical student now runs much risk of becoming a realist. But some of the methods which have freed him from the ancient snare and, perhaps, the language in which he sometimes describes them, have deceived the public. Thus we, as a profession, connect by an unbroken chain of causality—let us suppose—diseases of the enteric group and contamination of the food supply. We are, indeed, satisfied that substantial protection against a particular micro-organism is afforded by antityphoid vaccine, against other organisms epidemiologically similar by paratyphoid vaccines. We do not, however, suppose that were the entire community so protected, but no measures taken to secure the food supplies, water-borne and food-borne diseases would cease to scourge mankind. We should, on the other hand, confidently anticipate the emergence of other epidemiological forms against each of which we should hope a specific protection might be discovered; but we should hold that as each form was conquered another would take its place in endless series, so long as the original source of and predisponent to disease existed.

Here precisely is the difference between the physician and the layman, or medical correspondent of the daily press. The layman is a realist. He honestly believes that if the "cause" of "influenza" could be shown on a plate and a suitable vaccine prepared, we should then be in a position to make an end of "influenza." This being admitted, there is no inconsistency between the demand for intensive "team work" at public expense and the furious outcry against, say, expenditure on dentistry or health centres. The layman, like the late German Emperor, dreams of a short brilliant campaign which shall

"conquer" the zymotic diseases by discovering their "germs" and providing vaccines. The world is to go on just as before, save that these realities are to be eliminated. The physician remembers *naturam expellas furca tamen usque recurret*, and is less optimistic.

It has often been said that a community can purchase health, but the question must be faced whether the price to be paid is not so high that an attempt to find it will dissolve the community. It is not the business of medical men as such to answer that question, but it is their duty to state that the price must be very high, that the task of preventive medicine is something larger than the campaigning against germs.

The rationale of a hygienic life has been known for thousands of years. Celsus—with his prescription of a varied regimen, of moderate exercise, sometimes "to be in the city, sometimes in the country, the open air above all"—was at one with Dr. Leonard Hill; but his rules were qualified by a little phrase which in his time made them of small effect to a majority. They only applied to the man who could live as he pleased (*suae spontis est*). The task of the sanitarian has been to determine which of the factors governing the lives of those who cannot live as they please are most noxious. Eighty years ago the housing question was first seriously raised and urban sanitation taken in hand. The most pessimistic will not deny that the second problem is now less formidable; the most optimistic cannot regard the housing position with equanimity. In the meantime other difficulties have either been created or increased by industrial progress, such as the consequences of mass production in factories upon the health of the operatives. We now seek to know how the millions who must live their lives under conditions unlike those of primitive man, unlike those of the small minority to whom most ancient literature was addressed, can be safeguarded physiologically. In comparison with this problem that of "unemployment," a mere affair of distribution, is simple; yet the question of "unemployment" is still acute. Sir George Newman in his first report to the Minister of Health wrote: "Our business at the Ministry of Health is not to build for to-day or to-morrow, but for the future, not to attempt to settle forthwith this or that or the other local specific health problem, but to view such problems as parts of a whole, and slowly but surely to lay foundations which will endure."

This is the sentiment general among medical men, and is utterly repugnant to the intensive campaigning spirit of the lay journalist. We are not only to recognize for ourselves but to teach our fellow citizens the principle of continuity between physiology and pathology, so that they may learn that, for instance, dental prophylaxis is not an extravagant luxury, nor the teaching of hygiene in schools an attempt to deprive the poor man of his beer.

But above all we, as members of the medical profession, must preach the sermon that the way to national health is long and toilsome, and that the "path to a clear-purposed goal" does truly lead "a long, steep journey, through sunk gorges, o'er mountains in snow."

Those who tread this path, whether "bureaucrats" or private practitioners, need expect little encouragement from the popular press: they are more likely to encounter opposition and ridicule. But if, as we believe, this opposition is not the fruit of ill-will but of ignorance, the future is not wholly dark provided the medical man lives up to the original meaning of his popular appellation.

NEW YEAR HONOURS LIST.

THE New Year Honours List as it affects medicine is unusually short, and is chiefly remarkable for the recognition accorded to medical journalism, as an element in the life of the nation, by the knighthoods conferred on the Editors of the *Lancet* and of the *British Medical Journal*. Dr. William Hodgson, who also receives the honour of knighthood, has done much public work in the town of Crewe; he was a member of the town council for many years, and mayor in 1892-3. He has been a member of the Cheshire County Council since its formation; he is an alderman and vice-chairman of that body, and chairman of the Cheshire Education Committee. He is also a member of many other county committees, and has set an example to other members of the profession which should encourage them to take their share in the public life of the localities in which they practise. He is a member of the Insurance Acts Committee. Sir E. Coey Bigger is medical member of the Local Government Board in Ireland, chairman of the Irish Public Health Council and Central Midwives Board, and Crown representative on the General Medical Council. Sir Charles Ryall is a member of the Council of the Royal College of Surgeons of England, and Sir Frederick Hewett is a medical member of the household of the King and of Queen Alexandra. The knighthood to Sir P. J. Michelli recognizes important services rendered to medicine in the department of tropical diseases. He has been secretary of the Seamen's Hospital since 1887 and of the London School of Tropical Medicine since its foundation in 1899. He has recently had a large share in carrying through the establishment of the School with its special hospital in the buildings at Endsleigh Gardens. A full list of the medical honours is printed at p. 61.

MEDICAL DRAINAGE OF THE BILIARY TRACT.

By a happy combination of ideas derived from S. J. Meltzer's physiological observations on the one hand, with the use of Einhorn's duodenal tube on the other hand, Dr. B. B. Vincent Lyon of Philadelphia has during the last three years worked out a method of draining the bile ducts and gall bladder which has already given excellent results in the diagnosis, prevention, and treatment of biliary disease, and gives promise of far-reaching importance. In 1917 Meltzer formulated his conception of contrary innervation as applied to the filling and emptying of the gall bladder; Oddi's sphincter at the lower end of the common bile duct and the musculature of the gall bladder are supplied with inhibitory and motor fibres from the splanchnic and vagus nerves, which act antagonistically to each other, so that when the sphincter is relaxed the gall bladder contracts and vice versa. He also showed that the application of a solution of magnesium sulphate to the mucous membrane of the duodenum was followed by relaxation of Oddi's sphincter, a result which was not produced when the salt was taken by the mouth. His hint that this observation should be utilized in human disease has been acted on by Lyon,¹ who has published a series of papers containing observations and suggestions of great importance for future developments in medical and, indeed, in surgical practice. Lyon believes that the application of magnesium sulphate to the duodenal mucosa induces contraction of the gall bladder, and that incision of the gall bladder or disease of its walls removes the normal antagonistic action of the gall bladder and Oddi's sphincter, so that bile then runs continuously into the duodenum. The technique of the introduction of the duodenal tube is too long to quote; but it may be mentioned that the patient is examined twelve hours after a meal, contamination of the duodenal contents from the mouth and stomach being obviated by frequent washings; when the tube has entered the duodenum 75 cm. of a 33 per cent. solution of mag-

nesium sulphate is introduced, and the contents are then gently aspirated. In health the first bile thus obtained is of a light yellow-golden colour, and comes from the common bile duct; after a short time the bile suddenly changes to a darker golden yellow, becomes more viscid and larger in quantity; this bile is regarded as coming from the gall bladder; later bile of a lemon colour, thinner and more limpid than the other two, follows and is believed to be that freshly secreted by the liver. The normal gall bladder contains 1½ oz. to 2½ oz. of bile, but in stasis or atony of the gall bladder as much as six ounces may be obtained, provided, of course, that the cystic duct is patent. These characters of the bile change as the result of biliary infections, and comparison of the three samples, which can be separated into different bottles, will indicate what part—the gall bladder or common bile duct—is infected or mainly involved. Chemical, microscopical, and bacteriological examination of the bile can thus provide an early diagnosis; and, as Dr. G. E. Brown² points out in a recent article on "The Meltzer-Lyon method in the diagnosis of infections of the biliary tract," early cholecystitis can be detected at a stage when the clinical manifestations—indigestion and minor colic—are vague, and the gall bladder does not show any thickening or colour changes to the naked eye, so that bacteriological examination of the aspirated bile provides the surgeon with data he might fail to obtain from an exploratory laparotomy. When more than two and a half ounces of gall-bladder bile is obtained by aspiration, the diagnosis of stasis is justified, and by means of repeated aspirations this condition, which is of such importance in favouring infection and cholelithiasis, can be obviated. In cholelithiasis the bile may convey a gritty feeling to the finger, and microscopically show clustered masses of precipitated bile salts or pigment; on one occasion small concretions were aspirated through the tube, and several times calculi too large to be recovered by the tube were passed by the bowel after aspiration. Treatment of simple catarrhal jaundice by repeated aspiration of bile and subsequent disinfection with permanganate or silver nitrate solution diminished the duration of the disease by half, and probably minimized the risk of sequels. This method is not only of use in the treatment of early inflammations of the gall bladder and bile ducts, but may be valuable in infections persisting or recurring after operation. Further, there is a wide scope for investigation on the lines opened up by this method, on the action of cholagogues, on the early stages of biliary stasis, on the so-called functional disorders of the liver, and on the changes of the pancreatic juice.

A SIXTEENTH-CENTURY SCHEME FOR A
LONDON UNIVERSITY.

ALTHOUGH Sir Humphrey Gilbert (1539-1583), the half-brother of Sir Walter Raleigh, is best remembered as a navigator, the *Dictionary of National Biography* points out that the scheme that he laid before Queen Elizabeth, about the year 1572, for "the erection of an Achademy in London for education of her Maiestes wards, and others the youth of nobility and gentlemen" adds more to his literary fame than anything he ever undertook either as a soldier or a colonist. This curious anticipation of modern efforts to obtain a teaching as well as an examining University in London has attracted the attention of Mr. L. M. Griffiths, who reproduces parts of Gilbert's MS. (British Museum, Lansdowne MS. 98) in a short but scholarly note.³ Although educated at Eton and Oxford, Gilbert spoke disparagingly of Oxford and Cambridge, considering that the students "are drawn into licentiousness and idleness; and, therefore, yt were every way better that they were in any other place than theare." His plan was intended to find a remedy for their deficiencies, and it is interesting to glance at the provisions for medical education: "There shall be

¹ B. B. Vincent Lyon, *Amer. Journ. Med. Sci.*, Philadelphia, 1920, lix, 503; cli, 515. *New York Med. Journ.*, 1920, cxii, 23, 56.

² G. E. Brown; *Journ. Amer. Med. Assoc.*, Chicago, 1920, lxxv, 1414.

³ L. M. Griffiths, *Bristol Med.-Chir. Journ.*, 1920, xxxvii, 1-7.

entertained one Doctor of phisick, who shall one day reade phisick and another daie Chirurgerie, in the Englishe toung, touching all Kinds of Vleers, Sores, Phistiloes, Woundes, Etc. Together with all kindes of medicines for the same, as well Chimice (chemical) as otherwise." . . . "The Phisition shall practice to reade Chirurgerie, because thorough wante of learning therein, we haue verie few good Chirurgions, yf any at all, by reason that Chirurgerie is not now to be learned in any other place than in a Barbors shoppe." Research was specially indicated in the following words, which somewhat resemble those of Harvey's exhortation of 1656, that "this phisition shall continually practice together with the naturall philosopher, by the fire and otherwise, to search and try out the secreates of nature as many waies as they possible can." The keeper of the library has his duties defined, and the Copyright Act is anticipated in the proviso that "all Printers in England shall for ever be charged to deliuer into the Librery of the Achademy, at their owne charges, one copy, well bownde, of euery booke, proclamacion, or pamphlette that they shall print."

THE INSURANCE RECORD CARDS.

THE new medical record cards for insured persons came into use on January 1st: they are intended to contain a complete record of all the illnesses for which the individual is treated during his or her life. The system, which has been devised as an improvement upon that in use before the war, has been severely criticized by those newspapers which appear to be engaged in a campaign against the Ministry of Health. Granted the condition—namely, a medical service as part of a compulsory insurance scheme to which the State contributes—we do not think the charge is well founded. Under any State system there cannot be the absolute secrecy which exists in private practice, but the Interdepartmental Committee, over which Sir Humphry Rolleston presided, recommended precautions which, if observed, ought to prevent leakage. The card, with its medical notes, remains in the custody of the doctor until the insured person leaves the neighbourhood or for some other reason changes his doctor; in that case it is the doctor's duty to close the "window" envelope, as described in the SUPPLEMENT this week, and send it in another closed envelope by post to the clerk of the Insurance Committee of the district. We do not find that it is anywhere specifically stated that the doctor should close the "window" envelope before parting with it, but no doubt this is the intention. In the event of an insured person's death his doctor will forward his record card to the Insurance Committee; by it the card will be transmitted to the Insurance Department of the Ministry of Health; there it will be dealt with at once unopened in a clearing house; subsequently it may be opened and used for statistical purposes under the direction of the medical staff of the Insurance Department. The system has been fully explained in a memorandum addressed by the Ministry to doctors engaged in insurance practice; but others may find the article published in the SUPPLEMENT useful in recalling the circumstances. It is also objected that there is a breach of professional confidence because the Ministry, through its medical officers or persons they may appoint, has the right to inspect the records in the hands of the doctor. Here again we have a consequence of the interference of the State in matters so intimate as personal health; the risk was pointed out during the discussion of the first Insurance Bill, but Parliament, with, so far as can be judged, the full approval of the persons who were to become insured persons, decided that the benefits of the insurance scheme would more than compensate for any disadvantages that attend State interference. The risk that some confidential clerk employed by the medical officers of the Ministry should come across the record of a private acquaintance exists, but it is small and ought to be sufficiently safeguarded

by the obligation of discretion and secrecy which the Ministry will no doubt impose on persons so employed. The frequency with which inspections of records are made does not, of course, affect the principle, but it may be doubted whether it would often be profitable to resort to this method. The data to be so obtained would not, as a rule, be of a nature to yield more than the simplest statistical results. The experience of the census is sufficient to prove this, and to prove also that a large statistical staff under expert direction would be necessary to achieve even so much. In saying this we are aware that the Insurance Acts Committee desired that the prime purpose of the records should be clinical and not statistical or administrative, but it is difficult to conceive any application of the data which would not involve the statistical method. The Conference of Local Medical and Panel Committees has agreed that the new form of record shall be given a trial, and no doubt much will be learnt both as to the merits and defects of the method during this year.

ALKALOIDS AND GLUCOSIDES.

M. EM. BOURQUELOT, professor of pharmacy in the School of Pharmacy of the University of Paris, has recently communicated to the Académie de Médecine a paper¹ describing a number of glucosides which he has recently prepared. Incidentally he deals with the history of the discovery of alkaloids and glucosides. The first alkaloid to be isolated was morphine, and its discovery is generally attributed to a Hanoverian pharmacist, Sertürner, whose report on its isolation was published in 1806. He showed for the first time that it behaved like an alkali, forming salts with acids, but Bourquelot points out that the same body had been identified some years earlier by Dérosne, a Paris pharmacist. Dérosne published his results in the *Annales de Chimie* of the 30th ventose of the year XI (March 20th, 1803). By precipitating a solution of opium with potassium carbonate he obtained a crystalline body which he called a salt, although he recognized that it was not really of that nature. Dérosne's method of obtaining what he called the "essential salt" of opium was in principle the same as is used for producing the alkaloids, which are now known to the number, it is said, of 250. Pelletier isolated emetine from the ipecacuanha root in 1817, strychnine was obtained in 1818, and brucine in 1819, quinine and cinchonine in the following year, and codeine in 1831. The search, however, soon showed that alkaloids were not the only active principles that occur in plants. In 1820 a French pharmacist—Leroux—obtained salicin from willow bark; he supposed it to be an alkaloid, but Gay-Lussac showed that this was an error, as the body was neutral and did not form salts with acids. Certain other bodies of a similar nature were identified, and as, when decomposed, they were found to yield glucose they were called glucosides. Certain glucosides are hydrolyzed by emulsin, and M. Bourquelot has made use of the method founded on this observation. When he began the inquiry in 1901 only ten glucosides were known. He has added many, eleven of them from plants which are used, or have been used, as domestic remedies. Such a familiar shrub as the elder (*Sambucus nigra*) yields the glucoside sambunigrin, the cherry laurel (*Prunus lauro-cerasus*) prulaurasin, the leaves of the yew (*Taxus baccata*) taxicatin, and so on for veroin, hepatica, scabious, and several others. He has found glucosides also in a number of plants not used in medicine. Altogether 208 species of plants were examined, and evidence of a glucoside found in 149, although in only 56 was it isolated.

CERVICAL DEFECTS.

A RECENT number of the Italian journal which is devoted to the surgery of the locomotive organs² was entirely given up to an article of 104 pages on congenital

¹ *Bull. de l'Acad. de Méd.*, November 30th, 1920.

² *La Chirurgia degli Organi di Movimento*. Direttore, Dott. V. Putti. Vol. IV, Fasc. 4, with 84 figures in the text. Bologna: L. Cappelli, October, 1920.

anomalies of the cervical vertebrae by Dr. Mario Bertolotti, who is in charge of the radiological departments of the University of Turin and of the Ospedale Maggiore. This monograph is based upon 18 cases, of all but one of which radiographs are included. Most of the patients were brachicephalic, and in a number torticollis was present. One of them presented the usual features of a congenital muscular torticollis, such as shortening and sclerosis of the sterno-cleido-mastoid muscle and facial asymmetry, but a radiograph revealed the interesting fact that there was ossification of some of the deep muscles of the neck on the same side as the contracture. One case of cervical defect had also a typical spina bifida occulta in the loin. Several cases are described as "pseudo-Pott," the diagnosis of which might have been difficult but for the *x* rays, especially when scoliosis also was observed. The radiographs are very good and clear. The author has found that the best radiographic results are got by placing the patient prone, with the head in forced rotation to one side, and the source of the rays in a position corresponding to the tip of the fifth cervical vertebra. Two views are taken, one in a right anterior oblique, and the other in a left anterior oblique plane. The bibliographical supplement to this periodical is a useful publication.

SMOKE ABATEMENT AND THE EQUIPMENT OF DWELLINGS.

THE Departmental Committee on Smoke and Noxious Vapours Abatement, which was appointed in 1914, and resumed its work in the early part of 1920, formed the conclusion that, even in industrial areas, at least 50 per cent. of the pollution of the atmosphere by smoke—with the attendant evil effect on human health, as well as on vegetation and agriculture, on live stock and milk—is due to domestic chimneys. In view of the many State-aided housing schemes lately begun or projected, the Committee issued on June 1st an interim report on the methods that might be employed to minimize the production of smoke in new houses, where "a unique opportunity for constructive reform" exists. An account was given in our issue of August 7th, 1920 (p. 220), of the investigations and conclusions set out in this report. The Ministry of Health, which had previously drawn the attention of housing commissioners to the report, has now issued a general housing memorandum (No. 40), in which are indicated in general outline the best methods for putting the Departmental Committee's recommendations into practice. For the ordinary coal-burning cooking range, of which the comparative inefficiency and the wastefulness, both in fuel and labour, are recognized by many householders as well as by the experts who gave evidence before the Commission, the substitution of a gas-cooker is advocated; where gas is not available the alternative of electric cooking or ranges which burn coke or anthracite should be considered. It must be remembered that anthracite heating requires special stoves and special arrangements for ventilation: ranges designed to burn this fuel, however, are already on the market. For hot water supply the memorandum recommends the provision of means other than the boiler at the back of the open coal fire; thus the installation of a small coke-fire boiler placed in the scullery is described as satisfactory, cheap, and efficient, and it has the additional advantage of enabling a certain amount of auxiliary heating to be obtained from radiators supplied by the same boiler. For warming the living-rooms or bedrooms the provision of coke-burning grates, of gas fires, or of hot-water radiators is enjoined. Local circumstances of course differ very much, particularly as between urban and rural areas: nevertheless, so much importance is attached to the recommendations of the Departmental Committee, that in accordance therewith local authorities are asked to consider the practicability of modifying the projected heating and cooking arrangements of dwellings which have not yet been completed. As was

pointed out by the Committee, abolition of the open coal grate will diminish expenditure in that brick fireplaces, large flues, and chimney stacks will not be required; this should be found to counterbalance the cost of the smoke-preventive equipment, and in some instances it is anticipated that adoption of modern heating equipment will lead to an actual saving. The Housing Commissioner is prepared to confer with local authorities on the question of a central installation for the hot-water supply and heating of a number of houses. Against the extra cost of such a system should be set a considerably lessened cost of construction.

MEDICINAL HERBS.

THE famous *tisanes* which constitute the basis of domestic therapeutics in France are virtually unknown on this side of the Channel, and only a few old-fashioned housewives are familiar with the demulcent properties of marsh mallow, the sedative effects of verbena, the expectorant qualities of eucalyptus leaves, the diuretic properties of couch-grass (especially when associated with nitre), and the alleged depurative action of sarsaparilla. By far the greater part of the medicinal herbs utilized in this country are imported, in spite of the fact that many of them might very well be cultivated at home. It is even more surprising to learn that in France, where *tisanes* are so popular, huge quantities of herbs are imported, to the detriment of the national exchequer. It may not be without interest to look down the list of these importations. Arnica figures for four tons and costs £20 a hundredweight for the flowers, £7 for the root; blackthorn (*Rhamnus frangula*), a favourite laxative for children, 21 tons at £6 the cwt.; mullein, a popular demulcent, 4 tons at £24 the cwt. Camomile flowers, stomachic and antispasmodic, are in great request, since, in addition to being largely cultivated in France, 41 tons are imported at £24 a cwt. Far and away above the other herbs in point of popularity is couch grass, of which as much as 127 tons enters France every year at £7 a cwt. Eleven tons of male fern were imported at £26 a cwt., and nearly the same weight of ash-tree leaves for purgative purposes. Seventeen tons of gentian and 70 tons of marsh mallow seem reasonable, but it is difficult to imagine that it should be necessary to import nearly 5 tons of the ordinary common nettle and 94 tons of cherry stalks, the latter being reputed highly diuretic. Fifty-eight tons of coltsfoot (*Tussilago*), another demulcent, and 42 tons of violet petals, the last named at £36 a cwt.! We have not exhausted the list by any means, but we have said enough to establish the importance of this branch of commerce, especially when it is borne in mind that no mention is made of such drugs as digitalis and hyoseyamus and the like.

THE Registrar of the General Medical Council informs us that by an Order in Council dated December 21st, 1920, since the Kingdom of Belgium no longer affords to the medical practitioners of the United Kingdom such privileges of practising in Belgium as were offered during the late war, His Majesty has ordered that the Order in Council of January 7th, 1915, be revoked without prejudice to the right of any persons whose names have already been registered. Persons possessing Belgian qualifications are therefore no longer entitled to registration in the *Medical Register* of the United Kingdom.

Six Hunterian lectures on the Principles of Human Craniology, illustrated by specimens and preparations, will be delivered by Professor Arthur Keith in the theatre of the Royal College of Surgeons of England in Lincoln's Inn Fields at 5 o'clock on January 17th, 19th, 21st, 24th, 26th, and 28th.

NEW YEAR HONOURS.

THE New Year Honours announced on January 1st include awards to the following members of the medical profession :

Knighthood.

- DAWSON WILLIAMS, C.B.E., M.D., D.Sc., F.R.C.P., Editor of the *British Medical Journal*.
- S. SQUIRE SPRIGGE, M.A., M.D., Editor of the *Lancet*.
- CHARLES RYALL, C.B.E., F.R.C.S., Senior Surgeon to the Cancer Hospital and to the Bolingbroke Hospital.
- WILLIAM HODGSON, L.R.C.P.I., L.R.F.P.S.Glasg., For public services in Crewe.
- EDWARD COEY BIGGER, M.D., M.Ch., Chairman of the Irish Public Health Council and Medical Member of Local Government Board, Ireland.
- ALEXANDER JARVIE HOOD, M.B., C.M., Senior Honorary Physician, Prince of Wales's (Military) Hospital, Raudwick, New South Wales.

K.C.B. (Military Division).

- MAJOR-GENERAL ROBERT PORTER, C.B., C.M.G., M.B., Army Medical Service (ret. pay).

K.C.V.O.

- FREDERICK STANLEY HEWETT, M.V.O., M.D., Surgeon-Apothecary to the King and His Majesty's Household; and to Queen Alexandra and Her Majesty's Household.

C.V.O.

- WILLIAM FAIRBANK, M.V.O., O.B.E., Surgeon in Ordinary to His Majesty's Household, Windsor Castle.

C.M.G.

- EDWARD CHARLES LONG, Principal Medical Officer, Basutoland.
- THOMAS EDMUND RICE, Director of the Medical and Sanitary Services, Nigeria, formerly P.M.O. Sierra Leone and the Gold Coast.

C.I.E.

- LIEUT.-COLONEL DAVID MACDONALD DAVIDSON, I.M.S., Civil Surgeon, Lahore, Punjab.
- LIEUT.-COLONEL FREDERICK O'KINEALY, I.M.S., Surgeon Superintendent, Presidency General Hospital, Calcutta, Bengal.
- LIEUT.-COLONEL WILLIAM FREDERICK HARVEY, I.M.S., Director, Central Research Institute, Kasauli, Punjab.
- LIEUT.-COLONEL JOHN LAWRENCE VAN GEZEL, late I.M.S., Examiner of Medical Stores, India Store Dépôt.

Kaisar-i-Hind Medal.

A Kaisar-i-Hind Medal, for public services in India of the first class, has been awarded to Miss Annetto Matilda Benson, M.D., B.Sc., formerly senior physician, Cama and Abless Hospitals, Bombay.

Surgeon Commander Christopher L. W. Buaton, R.N., has been promoted to the rank of Surgeon Captain.

A *Knighthood* has been conferred on Mr. P. J. Michelli, C.M.G., Secretary to the London School of Tropical Medicine, and the *C.I.E.* on Dr. Edwin John Butler, Imperial Mycologist, Pusa.

THE Lettsomian Lectures before the Medical Society of London will be delivered at 9 p.m. on February 7th, February 21st, and March 7th, by Mr. G. E. Gask; their subject this year is "Surgery of the lung and pleura." On Monday next, January 10th, there will be a pathological meeting; on January 24th papers will be read by Dr. Anthony Feiling and Dr. F. J. Crookshank. On February 14th a discussion on skin disease and its relation to internal disorder will be introduced by Sir James Gallo-way. On February 28th Dr. J. H. Ryffel will open a discussion on "The chemical estimation of gastric function," and on March 14th Sir Henry Gauvain will open a discussion on the "Non-operative treatment of surgical tuberculosis." The annual dinner is fixed for March 8th at the Wharfedale Rooms, Hotel Great Central. The second general meeting of the session will be held at 8 p.m. on May 23rd; at 9 o'clock the annual oration will be delivered by Lord Dawson of Penn, and this will be followed by a conversazione.

Medical Notes in Parliament.

Vaccination.

IN reply to Mr. Swan, who asked whether there was anything in the Vaccination Acts or Orders issued thereunder to prevent the performance of the operation of vaccination by registered medical practitioners, other than public vaccinators, with humanized lymph, and the performance of the operation by unregistered persons, Dr. Addison said that the answer was in the negative, but the Acts provided that the certificate of successful vaccination could only be given by a registered medical practitioner. In answer to a question by Mr. Tyas Wilson as to the supply of vaccine, Dr. Addison said that in addition to the Government lymph establishment, which manufactured vaccine lymph for the supply only to public vaccinators and medical officers of health, there were four private firms in England and Wales which manufactured lymph for sale. He had no jurisdiction over the private manufacture of vaccine lymph, but as regards the Government lymph establishment, all possible precautions were adopted to secure that the lymph was produced under the best conditions and was free from contamination.

In reply to Mr. Kenyon, on December 21st, Dr. Addison gave the following statement as to public vaccinations carried out in England and Wales during the past ten years and the expenditure involved :

Year.	No. of Successful Vaccinations and Revaccinations Performed by Public Vaccinators at the Cost of the Rates.	Approximate Expenditure incurred in respect of Public Vaccination.	
		Expenditure out of Local Rates.	Expenditure out of Exchequer Funds.
1909-1910	415,718	£ 183,000	£ 25,400
1910-1911	394,338	174,000	30,000
1911-1912	362,757	165,000	23,000
1912-1913	334,530	158,000	19,000
1913-1914	315,067	152,000	16,000
1914-1915	—	144,000	26,000
1915-1916	—	138,000	12,000
1916-1917	—	129,000	16,000
1917-1918	232,648	116,000	21,000
1918-1919	202,913	110,000	20,000

Ex-Service Men in Asylums. In answer to Mr. Lyle, on December 21st, 1920, Mr. Macpherson said that ex-service men confined in asylums and suffering from certifiable insanity due to war service were by special arrangements treated as Service patients with all the privileges of private patients. Their number on December 9th, 1920, was 5,634. The entire cost of their maintenance and treatment was borne by the Pensions Department, and treatment allowances were made on substantially the same basis as in other cases of in-patient treatment.

Lunacy Certificates.—Mr. F. Roberts asked, on December 23rd, 1920, what became of the original reception order and accompanying medical certificate of inmates of asylums who were dead or who had been discharged; and whether, as some issue might turn upon the integrity and security of the original document, he would take steps to secure that the originals should remain henceforth in the custody of the Lunacy Board, and be free from the interference with their contents. Dr. Addison replied that the original admission papers relating to dead or discharged patients were retained by the authorities of institutions for as long as, in their discretion, they thought necessary.

Divisional and Full-time Health Insurance Officers.—Sir A. Holbrook, on December 23rd, asked the salaries to be paid to the four divisional medical officers and the thirty-three whole-time outdoor medical officers recently appointed by the Minister of Health, and what he estimated would be their travelling expenses; what expenditure would be incurred for the clerical and nursing staffs to these officers; what payment had been sanctioned for rent and care of regional offices throughout the country; whether the Minister was aware that the appointment of these officers to supervise and direct panel doctors throughout the country was strongly resented by the medical profession; and whether in view of the expense he would reconsider his decision. Dr. Addison replied that the salary to be paid to the four divisional medical officers was at the rate of £1,600 a year, and for the thirty-three whole-time medical officers the salaries ranged from £1,000 to £1,400 a year, in all cases inclusive, and providing that no additional payment was to be paid in the shape of war bonus. The total travelling expenses of the staff for a full year was estimated at £8,000. In addition a clerk had been assigned in certain areas, and the cost of clerical assistance under this head was estimated at £2,700 a year. Where necessary nurses were employed to assist these medical officers at a fee of half a guinea a session. Where it had been necessary to rent premises for this work the arrangements had been made by the Office of Works. He was certainly not aware that the policy adopted was strongly resented by the medical profession. This policy, which was approved by Parliament in 1914, had been continuously supported by medical men and by the approved societies; it was sound in itself and would produce results abundantly justifying the expenditure, in the saving of health, and of the amounts paid in sickness benefit.

Scotland.

MR. D. M. GREIG OF DUNDEE.

MR. D. M. GREIG, F.R.C.S.Ed., who had been thirty years in Dundee, and was senior honorary surgeon to the Royal Infirmary, has just taken up duty as Conservator of the Museum of the Royal College of Surgeons in Edinburgh. At the close of the year a pleasant function was organized by the Presidents of the Forfarshire Medical Association and the Dundee Branch of the British Medical Association, when Professor Stalker, as spokesman of his colleagues, presented Mr. Greig with a cheque subscribed in token of their appreciation of his services to the profession, and of congratulation on his appointment to a post so congenial. On December 31st the Freedom of the City was conferred on Mr. Greig in recognition of his distinguished service to the public. This is the highest honour which the municipality can give to any one who is not of its own body, and though in modern times it has usually been confined to Premiers or others achieving eminence in a similar way, those who have known the qualities and range of Mr. Greig's work best appreciate the appropriateness of the distinction. In acknowledging the honour Mr. Greig spoke of the enormous increase in the number of operations now undertaken by surgeons. When he was a student, he said, there were in the Dundee Infirmary from eighty to ninety operations a year, whereas in a recent year he had himself done over 2,000 operations. The conferring of the freedom was made the occasion of a further tribute: valuable gifts were presented to Mr. Greig, his wife, and daughter. Mr. Greig's museum, known to some who had the opportunity of seeing it as a whole and by the specimens he produced from it to illustrate his teaching, is almost unique among modern private museums. It expresses, among other fine elements, an interest in craniology, persistent and active, from the time, more than thirty years ago, when Mr. Greig was first to recognize congenital parietal perforation in the living, till to day, when it numbers some three hundred skulls individually documented. The new post will give Mr. Greig scope for his skill as a conservator, and also time—which practice denied—for literary treatment of the valuable material known to be available in Mr. Greig's case records.

WAR LESSONS IN CIVIL LIFE.

On December 15th, 1920, Sir Henry Gray of Aberdeen addressed a large meeting of the Dundee Branch of the British Medical Association on the lessons of the war and their application to civil life. The address will be published shortly in full; it was highly appreciated, and several members joined in paying a tribute of thanks to Sir Henry Gray. The meeting was followed by a dinner, under the genial chairmanship of Dr. J. S. Y. Rogers, President of the Branch.

EDINBURGH ROYAL INFIRMARY.

The report of the managers of the Royal Infirmary of Edinburgh for the twelve months ended October 1st, 1920, shows that the total number of in-patients increased from 12,550 to 13,320. The average length of treatment was 24.05 days. In addition to the cases treated in the wards, 48,117 out-patients, most of whom attended several times, received medical and surgical aid and such dressings and surgical appliances as were necessary. During the period under review there was an average waiting list of 889 persons. While the ordinary income improved, the increase was by no means in ratio to the greatly increased cost of running the hospital, while heavy arrears of work in the way of painting and so forth had accumulated during the war. The ordinary funds being quite inadequate to meet the expenditure, the managers launched a special appeal; as a result the subscriptions for the year increased by nearly £46,500 over those in 1919, and a sum of more than £60,000 was collected for the improvements and extension fund. The ordinary income during the year was £127,127. The voluntary contributions directly attributable to the organized efforts of employees now amount to some £30,000 a year. This is nearly four times the yield from that source in the year before the war. The ordinary expenditure has exceeded all previous records; it was £130,668, or more than £28,000 greater than in 1919. The cost per occupied bed increased from £115 odd to £149 odd.

Ireland.

IRISH PUBLIC HEALTH.

SIR EDWARD COEY BIGGER, M.D., Chairman of the Irish Public Health Council and medical member of the Local Government Board, has been the recipient of many congratulations from members of the medical profession and of the public service in Ireland upon the knighthood conferred upon him. He has been actively identified with the public health work in Ireland since he commenced his career as a medical practitioner in 1883 in Belfast, where his family are well known. In 1900 he was appointed Medical Inspector of the Irish Local Government Board, and was a member of the Commission on Poor Law Reform. On the retirement of Sir Thomas Stafford, he was appointed Medical Commissioner of the Local Government Board. In June, 1919, he was made Chairman of the Irish Public Health Council, which was formed in connexion with the Ministry of Health Act, 1919. Sir Edward, in a recent interview with a representative of the *Freeman's Journal*, stated that the Irish Public Health Council had recently formulated a scheme which, if adopted, would have a far-reaching effect, both in the interests of efficiency and economy in the health, hospital, medical, and veterinary services in Ireland. The scheme, however, was still before the Government, and had not been put into operation. The Council was asked to formulate proposals with a view to the submission to Parliament of an Irish Public Health Bill, which would place the public health services in Ireland on a wider and more comprehensive basis, and, where necessary, make mandatory on the local health authorities various adoptive and permissive health enactments. The Council published its report (which was practically unanimous) last May. This report was subsequently approved by a meeting of delegates fully representative of the Irish medical profession. It was also approved by the Royal College of Physicians in Ireland and other important medical bodies. The present system of medical attendance upon the sick poor, established under the Medical Charities Act of 1851, ensured that no poor persons need be without free medical attendance and the necessary medicine when they were sick. That system of medical relief fulfilled a very useful purpose, but to meet more modern conditions it required to be wholly reorganized. It should, in his opinion, be completely separated from the Poor Law administration and remodelled with a view to removing any possibilities of abuse. The local area of control should be extended from the union to the county, and the system linked up with a general county public health, medical, and hospital scheme. Sir Edward said that the Irish Public Health Council had recommended that a system of medical treatment should be provided as part of a general hospital system under the control of county health boards: (1) for insured persons on a contributory basis; and (2) for those who are admittedly unable to contribute. Drastic reforms were recommended for improving the conditions under which members of the medical profession would be called upon to carry out the treatment of the classes referred to. The hospitals in Ireland were under the control of various bodies, none of them public health authorities; they should be under the control of the sanitary authority, whose duty it is to prevent the spread of infection. The lunatic asylums were administered by separate committees. Co-ordination was not only required in hospital administration, but there was a great necessity for a simplification and a unification of the mode of administration of local and special hospitals. One of the most important and essential conditions of the public health services, Sir Edward Coey Bigger urged, was the appointment of county medical officers of health, and the transference of all health administration to the county health authority.

THE HENRY MOORE MEMORIAL.

Friends of the late Lieut.-Colonel Henry Moore, who died of wounds while on service in France, resolved that the memorial they wished to raise to his memory would best be established in connexion with the City of Dublin Hospital, to which he was surgeon for twenty-two years. At a gathering of the subscribers at the hospital the

memorial was formally presented and accepted by Dr. G. Jameson Johnston, the senior surgeon. It consisted of a brass tablet and a sum of £700 for a male bed and a child's cot. The tablet, which has been erected in the entrance hall, bears the following inscription:

In memory of Lieut.-Colonel Henry Moore, D.S.O., M.C., Surgeon to the Royal City of Dublin Hospital, 1896-1918. This Tablet, together with Memorial Beds, has been instituted by a number of those who desire to preserve his name as a zealous worker in the interests of the Hospital, and a man truly devoted to his profession. Kindly to all, and a friend of many, he served in the Great War from Mons until his death, at Wimereux, from wounds received in the discharge of his duty, on the 29th May, 1918.

County Court Judge Pigot, who made the presentation, recalled that Lieut.-Colonel Moore had served during the South African campaign as well as for four years during the Great War.

England and Wales.

THE L.C.C. AND THE TRAINING OF PUPIL MIDWIVES.

The Ministry of Health, in a recent communication to the Central Midwives Board, offered to arrange for the women medical officers and nurse inspectors on the staff of the Ministry to inspect and advise the Board upon midwives or institutions desirous of obtaining the Board's sanction to undertake the training of pupil midwives. This is a service which has been undertaken under the Midwives Acts by the officers of the London County Council who are qualified women medical practitioners in conjunction with their ordinary duties, and as the Ministry's offer indicated the possibility of overlapping, the London County Council communicated with the Ministry. The reply, read at the meeting of the Council on December 14th, repeated that the offer had been made, but that it rested with the Central Midwives Board to decide in each case whether it would ask for a report from the officer of the local supervising authority or from an officer of the Ministry. The Ministry's reply was regarded as unsatisfactory by the Midwives Acts Committee of the Council, who stated that there was no reason to suppose that the Board was dissatisfied with the assistance rendered by the Council's inspectors in the matter, and the Council recorded its opinion that the action of the Ministry was unnecessary, would lead to confusion, and would involve a wasteful employment of staff. The Minister is to be asked to receive a deputation on the subject.

BRISTOL MEDICAL SCHOOL.

The guest of the evening at the annual dinner of the Medical School of the University of Bristol, held under the presidency of Dr. George Parker, was Sir Robert Jones, K.B.E. Dr. C. Ferrier Walters, surgeon to the Bristol Royal Infirmary, in proposing his health, said that Sir Robert's mission in life had been the improvement, correction, and cure of those ill, diseases, and deformities which man had reaped by his neglect of nature, by his ignorance, his carelessness, or his misfortune. His had been the leading part in the organization of the magnificent orthopaedic hospitals, through which thousands of wounded men had returned to civil life. Thus, after long years, he had come into his own. Mr. Walters also referred to Sir Robert's goodness to the younger men and his extraordinary interest in their work. Sir Robert Jones, in reply, recounted some of his early experiences in endeavouring to induce the War Office to form an orthopaedic department in the army. He concluded by proposing the toast of "The Medical School and University." In Sir Isambard Owen, who had done so much to build up its reputation, the university had, he said, a medical and scientific vice-chancellor who had rendered it great services. Professor Fawcett, dean of the school, in response, compared the magnificent quarters now occupied by the school with the buildings when he first joined it twenty-seven years ago. Bristol had become the envy of other universities. This was due largely to the generosity of the Wills family; but more had to be done, for all lectures ought to be paid, and there should be endowed scholarships for research open to young graduates. No other school could offer better facilities for clinical work

than Bristol, and it might be added that it held a remarkable position as regards games, both cricket and football. Professor Tyndall, replying for the science faculty, expressed the hope that there would in future be more co-operation between medical men and chemists and physicists. Mr. Richardson Cross proposed the toast of "The Past and Present Students," which was acknowledged by Dr. D. T. Price, Miss Golding, and Mr. G. Bash.

Australia.

PROFESSORSHIP OF ANATOMY AT SYDNEY UNIVERSITY.

The Senate of Sydney University has decided to appoint a full professor of anatomy, in succession to Professor J. T. Wilson, who now occupies the chair of anatomy at Cambridge, and also an associate professor. This division of the chair has become necessary in consequence of the large number of medical students now passing through the medical school. The position of associate professor has been filled by the appointment of a Sydney graduate, Dr. John I. Hunter, who has been a demonstrator in the Department of Anatomy for several years. He was born in Victoria in 1898, and is thus only 22 years of age. After a public school education he entered the Sydney University with a bursary in 1915. He had a brilliant career, and graduated M.B., Ch.M. last March. He has proved his ability as a teacher and demonstrator, and has given proof of ability in original research. Few who know Dr. Hunter are surprised at his appointment, for great things have always been expected of him.

THE INFLUENZA EPIDEMIC IN WESTERN AUSTRALIA.

The influenza epidemic in 1919 caused the death rate in Western Australia to rise from 9.1 to 11.1. In his report for the two years ending December 31st, 1919, Dr. R. C. Everitt Atkinson, commissioner of public health and principal medical officer, describes how the State authorities, warned by the devastating outbreak in New Zealand, were able to formulate measures of quarantine, isolation, and inoculation for combating the spread of influenza if the epidemic should reach Western Australia. After influenza had been notified from Victoria in January, 1919, quarantine was instituted at points of communication both by land and by sea. Unfortunately the quarantine arrangements led in both instances to considerable friction with the Commonwealth authorities; the trouble seems to have been due, on the one hand, to the commandeering of railway travelling stock as quarantine stations and on the other, to disagreement as to the period of quarantine necessary for sea travellers. It is believed that by the institution of quarantine the introduction of infection was delayed and its virulence diminished; in the early days of June, however, an outbreak of fifty-seven cases occurred at Gwalia, and spread in spite of a locally instituted quarantine, to other districts. Perth was infected on June 6th, and the last area to be reached was Broome (November 25th). Clinically the infection resembled that occurring annually in the state, save for the greater subsequent prostration and the frequency of serious lung complications. Haemorrhages from the nose, pharynx, bowel, bladder, and uterus were common; abortion was frequent in pregnant women, of whom many died. Syphilitics did extremely badly; the same was observed of chronic alcoholics, but moderate drinkers, it is stated, seemed to have some immunity. In males the greatest number of deaths occurred between the ages of 30 and 35, and in females between 25 and 30; twice as many males died from influenza as females. Nearly 100,000 inoculations were given at public dépôts and at public expense; although no properly controlled evidence is available as to the value of this measure, the majority of practitioners thought it afforded a considerable degree of protection against the more serious complications.

MESSRS. JOHN BALE, SONS, AND DANIELSSON, LTD., inform us that they have recently published English editions of Drs. Cruchet and Moulmier's book on Air Sickness, and of Drs. Maublanc and Rati's book on Medical Examination of Airmen, reviewed in our last issue at p. 18.

Correspondence.

THE STUDY OF HEART DISEASE.

SIR,—In his valuable lecture on "The Study of Heart Disease" (BRITISH MEDICAL JOURNAL, December 11th, 1920) Dr. Poynton regrets that the possibilities of methods of prevention "have not been fully explored"; and he asks, in relation to the responsibilities of rheumatism as a cause of cardiac lesions, "Is the general public sufficiently alive to the danger of this disease?" Practitioners who have had much experience in children's hospitals will, I imagine, agree with the negative implied in this question. The public is not alive to the danger, and this largely because to the public rheumatism means pain, and particularly pain in the joints. If this ignorance is to be dispelled the end can only be attained by the action of the medical profession. On several occasions during the last twenty years I have urged that the discovery of rheumatism in any of its manifestations in any member of a family ought to be the occasion for warning parents that any slight illness in one or other of their children probably carries the risk of heart disease, and that the only chance of protection is early and complete rest in bed. Not until this warning is a universal policy can it be said that the medical profession has taken all possible steps for the prevention of heart disease in early life.

Dr. Poynton recognizes that heart disease "as we see it in our hospitals is infrequent in the well-to-do," and suggests that this experience prompts "careful systematic inquiry into housing and clothing and school influences." Is it not probable that, without minimizing the agencies he proposes, an explanation of the contrast may be that in the richer classes of the community even apparently slight and trivial symptoms secure prompt rest in bed, while among the poorer classes this precaution is neglected or postponed? It will continue to be neglected or postponed until parents are systematically told that the mischief that has fallen on one of their children may be repeated in others unless rest is practised from the outset even of minor disturbances and complaints.

Everyone must admire Dr. Poynton's persevering efforts to ensure a thorough knowledge of rheumatism in early life in the medical profession, and must sympathize with his desire for "special arrangements for cases of early heart disease to have a long period of rest." But still more desirable is it to secure the rest at a date when prevention, not mere amelioration, is at least possible. This will be obtained only when rheumatism in one or other of its forms having appeared in a family, the parents learn from their medical advisers the actual risks which their children run. Other preventive agencies may perchance in time be discovered. But for the present we know of none but early and complete rest. It is for the profession to consider whether this knowledge is in practice applied as widely as it ought to be.—I am, etc.,

London, W., Dec. 22th, 1920.

C. O. HAWTHORNE.

THE MINISTRY OF HEALTH AND THE PROFESSION.

SIR,—In last week's issue of the JOURNAL Dr. Brackenbury hints rather vaguely that—

"A section of the lay press, certain politicians, lay administrators, and political wirepullers, influenced mainly by the tactics of party warfare, are attempting to undermine the position and machinery of the Ministry of Health";

and he urges our profession to come to the rescue.

It is to be hoped that we will do no such thing. As a profession and in our Association—as Dr. Brackenbury recognizes—we have no concern with politics and its many underhand ways. No doubt the very naughty conspiracies he refers to will meet in due time with their historic punishment. What can we know of the currents and cross-currents now seemingly at work; how can we possibly, therefore, steer a correct course if we launch out into the deep?

It is not possible that, as our profession for the first time is being drawn from its traditional retirement into closer touch with the political world, therefore becoming able to look down into the arena of political strife, many of us

feel that if there is to be any fighting we would wish to be there? But it must not be. Deliberate, individual partisan action on behalf of the present Ministry of Health—as quite recently shown in the *Times* by those at the moment recognized in our profession and Association as amongst its "leaders"—only breeds distrust and suspicion in the profession and also in politicians of all schools; thereby helping to defeat ultimately the very objects which we all have in view. The lack of restraint shown is to be deplored.

It is not for our profession nor the Association officially without due consideration and approval to take up the cudgels on behalf of any Ministry. Sufficient it should be for us to express our opinion on questions affecting health in plain and unmistakable language, and then to proceed to organize ourselves and public opinion in support of the same.

Our profession has spoken out on many recent occasions, and no doubt is prepared to do so again directly an opportunity occurs. Until then let us retain our detached position, and leave the political arena and its subterranean passages to those who seemingly consider life therein to be as the breath to their nostrils.

We must not forget the sorry plight of the peacemaker who ventured to interfere in a family discussion.—I am, etc.,

Hove, Jan. 3rd.

E. ROWLAND FOTHERGILL.

THE BEGINNINGS OF LIFE.

SIR,—I have read with much interest the leading article in your issue of December 25th, 1920, on "The Beginnings of Life." As a firm believer in the doctrines of my father, the late Dr. Charlton Bastian, F.R.S., I am specially interested in the new researches of Professor Benjamin Moore, F.R.S., and his co-workers on sunlight and the life of the sea.

I must demur, however, to a statement in your concluding paragraph. You say:

"It would seem that inquiries conducted along these lines into the functions of marine and fresh-water algae are more likely to bring us towards a solution of the origin of life than investigations directed to bacteria and fungi, which can exist only upon organic matter, whereas the primordial world could contain no such matter before the advent of life."

I would like to ask what is the authority for stating that bacteria and fungi can exist "only upon organic matter," and has this been definitely proved or disproved? In this connexion I would refer your readers to a short article entitled "The Simplest Kind of Protoplasm," to be found as an appendix to Dr. Bastian's small book, *The Nature and Origin of Living Matter* (Watts and Co., R.P.A. Cheap Reprints, No. 41).—I am, etc.,

W. BASTIAN.

Portsmouth, Dec. 27th, 1920.

Surgeon Commander R.N.

SIR,—I am interested to observe that the opinions of Professor Stanley Gardiner, Professor B. Moore, and others, as reported in your leading article, "The Beginnings of Life," in the JOURNAL of December 25th, 1920, p. 982, coincide with my own, as published twenty-one years ago.

In a paper entitled "What is Life?" read before the Birmingham Natural History and Philosophical Society on February 21st, 1899, and published in the *Proceedings* of that society for the same year, I advocated the theory that the "lability" of living substance is fundamentally due to the changeability of nitrogen compounds, and that nitrogen is the central element in all those chemical reactions which we regard as peculiarly vital.

Discussing the origin of life, the paper proceeds (pp. 61-63):

"Both our speculation and our experiments should be based on the assumption (in the absence of evidence to the contrary) that life is the same in its essence nowadays as when it first dawned on the earth; that the transition from inert to living matter is now going on by the same essential reactions as at all times, only that as the result of evolution the apparatus for the performance of these reactions has become highly specialized.

"Provisionally, then, I imagine some such reactions as the following to have occurred: that solar energy, acting on the water or damp earth containing the raw materials before mentioned (ammonia, oxides of nitrogen, CO₂, and the usual

salts, such as chlorides, sulphates, and phosphates of Na, K, Ca, Mg, Fe, caused dissociation and rearrangement of the atoms; that the nitrogen abstracted oxygen from its compounds with carbon, hydrogen, sulphur, phosphorus, and other elements and delivered it to the atmosphere. Not much energy would be absorbed by a transparent liquid; such actions as the above would occur rather in water containing compounds of iron in solution or suspension. These compounds would absorb the solar energy, and the iron itself would assist in carrying oxygen hither or thither; and hence possibly iron was as intimately concerned in the first glimmer of life in the past as in its mightiest flame to-day.

"In this way compounds of nitrogen, carbon, etc., would accumulate in the water or damp earth; and further reactions, anabolic and catabolic, would occur among them by virtue of the lability of the nitrogen compounds. Life at this stage would be of the humblest kind; we should hardly recognize it as life nowadays. There would be no definite organisms—only diffuse substances trading in energy. Between this stage and the evolution of cellular organisms an immense period may have elapsed, and that period may have witnessed many intermediate stages. The development of the cell form in living beings must have marked a most important epoch in the history of life.

"It may be a debatable question whether the earliest organisms were able to utilize the energy of sunshine or whether their whole energy was derived from the N compounds produced in the atmosphere by lightning. But in any case the faculty of appropriating the energy of sunshine must have developed early, if not at the very beginning. In the functions of life anabolism precedes catabolism; and one would therefore suppose that the earliest forms of life were concerned more in accumulating than in dispersing energy, and therefore that the energy-dispersing organisms, like bacteria and fungi, may have had a comparatively late origin. . . .

"I imagine that nitrogen-appropriating bacteria, growing on the roots of leguminous plants, cannot represent an early form of life or an early source of combined nitrogen. This assimilation of nitrogen is an anabolic process; but the energy for its performance is obtained, not from sunshine, but by combustion of carbon and hydrogen compounds which the said organisms absorb from the soil. The total result of the process is therefore a dispersion of the energy which other organisms had previously accumulated.

"My view of the origin of life implies that the first attempts at life are still continuing; and that if by chance all life were wiped out, another cycle would begin. Why, then, do we not find evidence of these processes in the shape of primitive vital substances in water or elsewhere? The answer is not far to seek. If any such substances begin to be formed, they are seized and assimilated by the already developed organisms. Experience teaches us that this must be so. We know that compounds of nitrogen, oxygen, carbon, hydrogen, sulphur, and phosphorus, which we make in the laboratory, are inconveniently prone to be attacked by lowly organisms."

—I am, etc.,

Cambridge, Jan. 1st.

F. J. ALLEN.

BRITISH AID FOR MEN OF LETTERS AND SCIENCE IN RUSSIA.

SIR,—We have recently been able to get some direct communication from men of science and men of letters in North Russia. Their condition is one of great privation and limitation. They share in the consequences of the almost complete economic exhaustion of Russia; like most people in that country they are ill-clad, underfed, and short of such physical necessities as make life tolerable.

Nevertheless a certain amount of scientific research and some literary work still goes on. The Bolsheviks were at first regardless and even in some cases hostile to these intellectual workers, but the Bolshevik Government has apparently come to realize something of the importance of scientific and literary work to the community, and the remnant—for deaths among them have been very numerous—the remnant of these people, the flower of the mental life of Russia, has now been gathered together into two special rationing organizations, which ensure at least the bare necessities of life for them.

These organizations have their headquarters in two buildings known as the House of Science and the House of Literature and Art. Under the former we note such great names as those of Pavlov the physiologist and Nobel prizeman, Karpinsky the geologist, Borodin the botanist, Belopolsky the astronomer, Tagantzev the criminologist, Oldenburg the orientalist and permanent secretary of the Petrograd Academy of Science, Koni, Bechterev, Latisher, Morozov, and many others familiar to the whole scientific world.

Several of these scientific men have been interviewed and affairs discussed with them, particularly as to whether anything could be done to help them. There were many

matters in which it would be possible to assist them, but upon one in particular they laid stress. Their thought and work is greatly impeded by the fact that they have seen practically no European books or publications since the revolution. This is an inconvenience amounting to real intellectual distress. In the hope that this condition may be relieved by an appeal to British scientific workers Professor Oldenburg formed a small committee and made a comprehensive list of books and publications needed by the intellectual community in Russia if it is to keep alive and abreast of the rest of the world.

It is, of course, necessary to be assured that any aid of this kind provided for literary and scientific men in Russia would reach its destination. The Bolshevik Government in Moscow, the Russian trade delegations in Reval and London, and our own authorities have therefore been consulted, and it would appear that there will be no obstacles to the transmission of this needed material to the House of Science and the House of Literature and Art. It can be got through by special facilities even under present conditions.

Many of the publications named in the Oldenburg list will have to be bought, the costs of transmission will be considerable, and accordingly, the undersigned have formed themselves into a small committee for the collection and administration of a fund for the supply of scientific and literary publications, and possibly, if the amount subscribed permits of it, of other necessities, to these Russian savants and men of letters.

We hope to work in close association with the Royal Society and other leading learned societies in this matter. The British Science Guild has kindly granted the Committee permission to use its address.

We appeal for subscriptions, and ask that cheques should be made out to the treasurer, C. Hagberg Wright, LL.D., and sent to the British Committee for Aiding Men of Letters and Science in Russia, British Science Guild offices, 6, John Street, Adelphi, London, W.C.2.—We are, etc.,

MONTAGU OF BEAULIEU,
ERNEST BARKER,
E. P. CATHCART,
A. S. EDDINGTON,
I. GOLLANCZ,
R. A. GREGORY,
P. CHALMERS MITCHELL,

BERNARD PARES,
ARTHUR SCHUSTER,
C. S. SHERRINGTON,
A. E. SHIPLEY,
H. G. WELLS,
A. SMITH WOODWARD,
C. HAGBERG WRIGHT.

December 31st, 1920.

THE RISKS AFTER OPERATIONS FOR TONSILS AND ADENOIDS IN OUTDOOR CLINICS.

SIR.—The profession and the public, no less than laryngologists, should be grateful to Mr. Eric Watson-Williams for his timely article in your issue of December 11th, 1920, in which he deals with the risks run by patients who are sent to their homes within an hour or two of the operation for the removal of tonsils and adenoids in out-patient clinics.

It is a subject which has long vexed those who have charge of these operations, and its solution seems still to be far off, because the beds allotted to the ear and throat departments of our hospitals, general and special, are few, and they are always filled by what are termed "urgent" cases, which demand major operative procedures. For these beds there is always a long waiting list, and hence the "tonsils and adenoids" have to be dealt with as out-patients, and for the present I can see no likelihood that beds will be provided for them so that they can be admitted as in-patients even for forty-eight hours.

Finding myself face to face with the insuperable difficulty outlined above, and experiencing the occasional complications which Mr. E. Watson-Williams has so clearly outlined in his communication, I adopted the plan of having the following printed directions given to the patients or their parents in the hope that we might reduce accidents to a minimum.

UNIVERSITY COLLEGE HOSPITAL EAR, NOSE AND THROAT DEPARTMENT.

Directions for the Care of Patients before and after the Removal of Tonsils and Adenoids.

1. At 6.30 to 7 o'clock on the morning of the day of operation give the child a light breakfast of thin bread-and-butter and a cup of weak tea, but after that give him nothing whatever either to eat or drink. The patient should be at the hospital at 9 a.m.
2. A parent or responsible adult must come with the patient. Please bring a wrap to travel in and also a clean towel.

3. After the operation, and when you are told the child may be removed, take him straight home, put him to bed and keep him there for two days. Give him nothing to eat or drink for at least four hours after the operation, then he may have a little warm milk, beef-
tea, broth, or weak tea, and in the evening a small basin of bread and milk.

4. On the day after the operation he may have any soft food to which he is accustomed.

5. During the first twelve hours following on the operation he may be sick and bring up some blood which has been swallowed, but if he bleeds from the nose or mouth without vomiting, give teaspoonfuls of iced water every two or three minutes for an hour. Should this fail to check the bleeding bring the child to the hospital or send for the nearest doctor.

6. Keep the child indoors for four days after the operation and avoid exposing him to bad smells and infection from people suffering from fever of any kind or from "a cold in the head."

7. Patients operated upon should attend the following week for examination.

These directions have been in use in my department for some fifteen years, and I have no shadow of doubt that they have had an excellent effect in reducing the number of avoidable complications after the removal of tonsils and adenoids.

It is in the hope that such "directions" may be useful to others that I have asked for them to be printed with this note. Incidentally I should like to add that:

1. No patient is operated upon as an out-patient unless he lives within a radius of three to four miles from the hospital. Beyond such a distance the patient waits his turn for admission as an in-patient, and is kept for at least forty-eight hours.

2. All tonsils are enucleated by one of the many methods employed for that operation.

3. No patient is allowed to leave the operating table until the tonsillar recesses have ceased to bleed. The majority of the cases of so-called "secondary haemorrhage" are really continued haemorrhage—that is, bleeding which was not checked at the time of operation.

4. Each patient is kept at rest in suitable cubicles for three to four hours before he returns to his home.

Under no consideration would I consent to operate on a patient in my own house and send him (or her) home in a car or carriage.—I am, etc.,

HERBERT TILLEY,

Surgeon, Ear and Throat Department,
University College Hospital, London.

London, W., Dec. 26th, 1920.

SIR,—I am much interested in the letters which have appeared recently in the JOURNAL on the above subject. That it is time that something is done in the matter there can be no doubt.

In this hospital no case is allowed to leave after operation if there is any sign of distress or of haemorrhage. The parent is warned to put the child to bed on arrival home and not to allow it out of doors for two days in the winter time. If there are any active conditions which are due to the presence of the tonsils and adenoids the case is taken into the hospital.

Sir William Milligan's remarks as to operations in consulting rooms are only too true. Until the public realize that the practised surgeon is the proper person to perform operations, I fear the consulting room will still continue to be used in this unwarranted manner.—I am, etc.,

J. A. GIBB,

Surgeon, Kent County Ophthalmic Hospital for
Diseases of the Eye, Ear, Nose and Throat.

Maidstone, Dec. 26th, 1920.

THE CONFERENCE ON VOLUNTARY HOSPITALS.

SIR,—I was greatly interested in your report of this conference. This is low it struck me:

Mr. Bishop Harman moved a resolution "of belief that the voluntary method of maintenance and staffing of the voluntary hospitals of the country is to the advantage of the public, of medical science, and of the medical profession." He only expressed pious opinions. He said, "Freedom was a necessary condition to the gathering of the best fruits of medical experience and practice." Freedom from what? Supposing the hospitals were State supported, and managed by a committee partly elected and partly co-opted, such as the Insurance Committee, what freedom would be lost? Let him answer. He yearned for charitable hospitals and necessitous patients, and doctors receiving no direct monetary emolument. He forgets that citizens want citizen hospitals, desire their doctors to be adequately paid, and the work done to be as efficient and up-to-date as possible. He suggested that it would be a distinct loss to the wealthy if they had no "charitable objects" to patronize.

Sir Henry Davy wanted a wage limit for patients, with its accompanying inquiries. His idea seemed to be turning the voluntary hospitals into charitable nursing homes, to be run by the doctors and the dispensers of charity, not without profit to the doctors. I would like to ask Sir Hamilton Balfour to state his reasons why the doctors should not be paid for services rendered. Dr. W. S. Dickie is only anxious that the doctors should not be paid.

Dr. Astley Clarke said the primary meaning of a voluntary hospital system was a system free from bureaucracy. What objection has he to a citizens' hospital, to which every citizen would have the right of admission, in which the doctors might be adequately paid for their work, and the majority of their committee consist of their own elected representatives?

Dr. Bolam hit the nail on the head when he said that many of the hospitals were run on the dispensary system, the only difference being that the doctors were not paid. Mr. Bishop Harman said it was because of the flavour of voluntarism that these hospitals were sought out by the State or municipality to perform special services—for example, the treatment of venereal disease. Does he really believe that? Up to last year I was a town councillor. We attached the venereal clinic to the local hospital. But I never heard a word about this flavour. All the town council thought of was how to get the work done most efficiently. The equipment and conveniences were at the local hospital, and so was the experienced doctor, whom they were willing to pay to do the work efficiently. Mr. Harman ingenuously confessed he could not defend voluntarism on logical grounds. He moved a resolution in favour of accepting State contributions, without any proportional control. Is he aware that this is the age of democracy?

May I also suggest that, as was discovered in Wigan, if the workers practically find the income for the hospital they will demand proportionate control? If the insurance companies do the same they will make the same demand. I may say that it was found impossible to establish a system of almoners in Wigan; the working man will not have it. Then the question arises, if money is to be paid by Insurance Committees, are they to be adequately represented on the boards of management? Then, finally, let me ask, in the words of Mr. A. E. Morison, why should it remain in existence—"that the only charitable part of the undertaking was the work of the medical and nursing staff"? Will some of the leaders of the profession at the meeting enlighten the public on this curious point: Why does the medical profession desire to do the staffing of hospitals without remuneration?—I am, etc.,

FERDINAND REES, M.D.,

Honorary Consulting Physician, Royal Albert
Edward Infirmary, Wigan.

January 3rd.

VENEREAL DISEASE PROPHYLAXIS.

SIR,—Though loath to intervene in the correspondence on the prophylaxis of venereal diseases, I feel that Dr. Bayly's letter in your issue of January 1st calls for a brief comment.

He appears to misunderstand completely the ethical objection to the propaganda of the Society for the Prevention of Venereal Disease. It is this—that the broadcast issue of their instructions implies a sanction to immorality on the part of the community, and that the logical issue of their teaching, namely, the constant carrying of a prophylactic outfit, must act as a continuous incitement to seek opportunities for its use.

But apart from this ethical objection there is the practical one, that the balance of available evidence is against the efficacy of this form of prophylaxis. Though official figures are not yet published, it is widely known that the incidence of venereal disease among our troops on the Rhine has reached an almost incredibly high figure. The reasons for this are doubtless complex, but the important fact from the point of view of the present controversy is this—that this has occurred in spite of the free supply to these troops of various prophylactics (including the much vaunted "permanganate") and an intensive campaign of instruction in their use.

In the face of this evidence Dr. Bayly's heroics regarding the iniquity of withholding this "scientific" knowledge from suffering mankind appear rather futile.—I am, etc.,

London, W., Jan. 1st.

OTTO MAY

SIR,—In your issue of January 1st Dr. J. Lorimer Hawthorne objects to the note by the Medical Women's Federation on self-disinfection on the grounds that it gives a wrong impression of the aims and methods of the Society for the Prevention of Venereal Disease. She suggests that the writers of the note to which she objects should have verified the accuracy of their information. That information is derived from the annual report for 1920, and from the speech of the president of the society. It is as follows:

"Therefore we are going to take every step that we can in order to ensure that all boys and girls, men and women in the United Kingdom shall have access to the latest scientific knowledge with regard to immediate self-disinfection."

Again:

"There are twelve towns which have already given instructions that the inhabitants shall be instructed in immediate self-disinfection."

Boys, girls, men, women, inhabitants!

Nothing in any of the public speeches of the agents of the Society for the Prevention of Venereal Disease, nor in their numerous communications to the press, nor in any of their published propaganda has, as far as I have seen or heard, given the public any reason to think that the aims and methods were anything other than those described by their president.

Their ideal, such as it was, appeared to be consistent. The Medical Women's Federation merely pointed out that in the case of those who most needed and deserved the promised protection—young girls and young married women—it would be almost bound to fail. Surely Dr. Hawthorne could do better in support of the organization that she champions than to characterize its aims as "unjustifiable and revolting"—for that, in effect, is what she does.

Dr. Hawthorne also considers the instruction of young boys and girls as "unjustifiable and revolting," although, mainly as a result of the work of her society, the boys of Manchester (and, for aught I know to the contrary, of other towns) can learn all that men can learn in the public lavatories.

As regards the "Directions for Women" (which the Medical Women's Federation has not yet criticized), it is interesting to learn that they should be known as "Directions for Prostitutes." Yet how, in view of the title, and in view of the presidential exposition of the society's aims, were the Medical Women's Federation to know that?

It turns out that instead of being an organization for safeguarding the young beginner, or all boys, girls, men, and women, the Society for the Prevention of Venereal Disease only proposes to apply its benefits to those who resort to prostitutes. The advertisement of its methods as new and scientific with, however, not greatly appeal to those who recognize a very old nostrum in a hardly newer setting. Nor is the public likely to wish to pay for this propaganda one moment after it understands its true meaning.

I put it to Dr. Hawthorne that the noble profession of medicine does not exist in order to fold its hands and say piously that what must be, must be. It is here, rather, to find out and to point men to what they are capable of becoming, and to the real and full enjoyment of all their instincts.

As regards the "Directions for Prostitutes," I ask Dr. Hawthorne to fix her medical imagination on a mucous surface which normally cleanses itself fairly effectively, and which tolerates greasy applications indifferently. Cover it with several layers of a very adhesive grease. Mix on this a layer of decomposing discharges and other debris. Repeat the layers several times. Imagine this in the majority of prostitutes who are poor women, imperfectly trained in cleanliness, careless, disbelieving in inunction—often afraid of it. Note the foul and dangerous surface that ensues. Consider this as a suitable surface for conveying "mediate" contagion. Let the patient douche herself with warm permanganate. Observe that the filthy surface is not removed thereby. Can any thinking person believe that such a "method" deserves the name of "scientific"?

Lastly, my experience is that numbers of prostitutes, amateur or professional, do have children. Some, no doubt, do away with their children, some are bad mothers, but many are cured of their abnormal habits, and

redeemed by a child. So that contraceptives are not entirely irrelevant to this question. Everyone is entitled to know the effects of drugs she is advised to use.—I am, etc.,

A MEMBER OF THE MEDICAL WOMEN'S
FEDERATION.

January 31.

THE NAVAL MEDICAL SERVICE.

SIR,—The six medical officers are to be congratulated on their letter in the *Journal* of December 11th, 1920. There are, however, some fundamental points to which I think it desirable to call attention in our efforts for reform.

Leadership.—The natural leader is the Director-General, but seeing that he has no seat at the Board of Admiralty the leadership must temporarily be a committee of the British Medical Association. Suitable leaders should be elected; at present very few of us know how the committee is formed. It is well known to most of us that the minor grievance in connexion with coroners' fees took seven years to settle.

Publication of the Durnford Report.—It is understood that this report contains an excellent basis of reform. An effort should be made to have it published. It could be published in the *Naval Medical Journal* without expense to the Admiralty. The ceaseless reiteration of grievances is futile. Action is the fashion of the day.

Financial.—Possibly the nation cannot bear the strain of increased allowances, as hinted at in the above mentioned letter; a solution, however, might be found in rear admirals and captains pooling their allowances with surgeon rear admirals and surgeon captains respectively.—I am, etc.,

December, 1920.

ACTION.

The Naval and Military Committee consists of two members appointed by the Representative Body, two by the Council, together with the representatives on the Council of the Royal Naval Medical Service, the Royal Air Force Medical Service, the Army Medical Service, and the Indian Medical Service.

MUSCLE RE-EDUCATION IN INFANTILE PARALYSIS.

SIR,—In reply to Dr. Mackay's letter in your issue of December 18th, I must repeat that I am still quite unable to understand how Dr. Mackay still insists that splinting and physiological rest *per se* form an integral portion of muscle re-education; his definition of the latter commences with the words "the gradual stimulation." Splinting and physiological rest cannot be regarded as a "gradual stimulation," though they may facilitate such stimulation applied subsequently by other methods.

The proof that splinting and physiological rest are not essential for recovery from infantile paralysis is a clinical one. One knows there have been hundreds and hundreds of cases in which both legs were affected who have never sought medical aid, but who have as soon as possible—often urged by parents—tried to walk again. In nearly every case such patient, upon discovering that one leg was more useful than the other, used it more, frequently ending up by employing it almost to the entire exclusion of the other. Yet in spite of the fact that the more useful leg was doing practically double work, and that it commenced to do so within a few days of the onset of the disease, that leg was the one to make a rapid and frequently perfect recovery, while the other leg, originally the less useful one, only showed feeble signs of recovery. Now if splinting and physiological rest were essential for improvement these cases would run a different course; the leg that was at first more useful would rapidly become weaker, while the other leg would soon catch it up and progress quicker. This, however, is hardly ever the case.

Nor can I agree with Dr. Mackay's statement that any treatment not based on the principles he advocates is mainly responsible for failures with infantile paralysis. I consider that they are due to other reasons, the two chief being: (1) that a vast amount of so-called Swedish treatment is given by masseurs and others who are totally incompetent to apply it; (2) the valuable method of nerve stimulation by the so-called "nerve frictions" (according to the methods of H. Kellgren) are to the profession as yet almost an unknown factor in mechano-therapeutics.

In any case I think that this controversy has lasted long enough. I suggest that we let theorizing alone, and that Dr. Mackay let us have his results. If they show an improvement as compared with the correctly applied genuine Swedish methods I shall be delighted to acknowledge the fact to Dr. Mackay. If they do not, doubtless he will be equally pleased to do so to me.—I am, etc.,

London, W., Dec. 18th, 1920.

EDGAR F. CYRIAX.

ANGIO-NEUROTIC OEDEMA TREATED BY INJECTIONS OF HORSE SERUM.

SIR,—Dr. T. Wood Locket's letter in your issue of December 18th, 1920, on the therapeutics of normal horse serum, prompts me to send you a note of the results of its exhibition in a case of angio-neurotic oedema which lately came under my care.

The patient, a coal-dealer, had previously been seen by my partner and also by a neighbouring practitioner, and had had, I believe, six attacks. One of these was so severe, and the tongue and neck so greatly swollen, that, as he appeared to be in danger of asphyxiation, my partner sent him to St. Bartholomew's Hospital, where he was admitted and kept under observation for several days.

I was called to his house on September 6th, and found him in bed with greatly swollen face, neck, tongue and lips. The lower lip was fully one and a half inches thick, and the features almost unrecognizable. Previous treatment having proved futile, and, influenced by a consideration of its antitoxic and thrombin-producing properties, I decided to try hypodermic injections of normal horse serum. I gave 5 c.cm. that evening, and at intervals of forty-eight hours 5 c.cm. and 10 c.cm. The swelling subsided rather more slowly than usual, and the patient was about at the week end and went to the seaside on Sunday. There he developed a profuse erythematous rash covering the body and limbs, and came home three days later. The rash soon disappeared, except over the sites of inoculation on the arms, where it became eczematous and persisted for several weeks.

This patient remained under my care for nine weeks, during which time he had one slight recurrence of the oedema, involving the eyelids and subocular tissue. Up to the present he has had no further attacks and remains quite well. In view of the fact that prior to receiving the horse serum injections he had seven severe attacks occurring at almost regular weekly intervals, I think I can fairly claim that this treatment has proved definitely curative in the case described.—I am, etc.,

London, E.C., Dec. 19th, 1920.

W. A. M. SWAN.

Universities and Colleges.

UNIVERSITY OF LONDON.

THE title of professor of pharmacology has been conferred upon Dr. F. Ransom (London School of Medicine for Women).

Mr. F. F. Burghard, C.B., has been appointed the representative on the Senate of the Royal College of Surgeons of England for the remainder of the period 1919-23, in succession to Sir Charles Ballance, K.C.M.G., C.B., M.V.O., resigned.

The first lecture arranged under a scheme for the exchange of lecturers in medicine between England and Holland will be given at the rooms of the Royal Society of Medicine (1, Wimpole Street, W.1) by Dr. J. K. A. Wertheim Salomonson (Professor of Neurology in the University of Amsterdam) on "Some Considerations on Tonus and Reflexes" at 5 p.m. on Monday, January 17th. The chair will be taken by the Vice-Chancellor of the University, Dr. S. Russell Wells. Five other Dutch lecturers will also give one lecture each, particulars of which will be announced later. The lectures, which will be delivered in English, are addressed to advanced students of the University and to others interested in the subject. Admission is free, without ticket.

A course of eight lectures on the Physiology of the Embryo, Foetus, and Newly-born will be given by Professor M. S. Pembrey, M.D., in the Physiological Theatre, Guy's Hospital, at 4.30 p.m. on Thursdays, January 13th, 20th, 27th, February 3rd, 10th, 17th, 24th, and March 3rd. The lectures are addressed to advanced students of the University and to others interested in the subject. Admission is free, without ticket. The course of lectures arranged to be given by Mr. J. A. Gardner has been postponed.]

Applications for the post of Professor of Obstetrics and Gynaecology and Director of the Obstetrical and Gynaecological Unit at the London (Royal Free Hospital) School of Medicine for Women (salary £2,000 a year) must be received by the Academic Registrar at the University by January 15th.

Applications for the Graham scholarship in pathology, value £400 per annum for two years, founded by the will of the late Dr. Charles Graham to enable a "young man to continue his pathological researches, and at the same time to secure his services to the School of Advanced Medical Studies connected

with University College Hospital as a teacher under the Professor of Pathology," must be received by the Principal Officer at the University by January 17th, 1921.

UNIVERSITY OF ST. ANDREWS.

At a meeting of the University Court on December 18th, the Very Reverend Principal Galloway, who presided, congratulated Professor Irvine on his appointment as Principal of the University.

Mr. D. M. Grieg's resignation of the post of lecturer in clinical surgery was accepted, and an expression of recognition of his services as a surgeon was adopted.

The following appointments were made: *Lecturers in Clinical Surgery*, Mr. John Anderson, D.S.O., and Mr. W. L. Robertson, M.C.; *Clinical Surgical Tutors*, Mr. John Taylor and Mr. F. A. Brown; *Clinical Tutor in Gynaecology*, Miss Margaret Fairlie; *Lecturer in Pathology*, Mr. G. R. Tadhope; *Honorary Demonstrator in the Department of Anatomy*, Miss Edith D. Dobbie; *Assistant to the Professor of Surgery*, Mr. F. A. Brown.

The following candidates have been approved at the examinations indicated:

THIRD M.B., Ch.B. (*Forensic Medicine and Public Health*).—D. A. K. Cassells, G. R. M. Cordier, W. A. Steel.
FINAL M.B., Ch.B.—Margaret J. M. Guthbert, Jean H. D. Fleming, Mabel Hodgson, Frances L. Knipe, Margherita M. Lilley, Christian E. Little, J. B. Macdonald.

LONDON SCHOOL OF TROPICAL MEDICINE.

THE following candidates have passed the examination of this school at the termination of the sixty-fourth session, October-December, 1920:

* P. A. Buxton ("Duncan Medal"), Surgeon-Lieut. Comdander H. B. Parker, R.N., H. G. Wiltshire, L. C. D. Hermitte, Major W. B. Cullen, I.M.S., Captain C. Heppenstall, I.M.S., R. H. Liscombe, Captain R. E. Flowerden, I.M.S., S. C. Bose, E. R. Kellersberger, G. V. Allen, A. A. Denham, Captain H. S. Haji, I.M.S., A. S. Paranjape, A. D. Gupta, C. J. Caddick, Z. S. Khaled, P. T. Liang, A. H. Patel, W. R. Taylor, D. F. Maya, S. Somasundram, W. E. de Silva, F. V. Jacques, Miss E. B. Salter, A. M. Kirdany, A. W. Hooker, Miss E. Lombard, A. K. Moilliet, Miss M. Gore, A. R. Mehta, O. van Stenis, Miss A. Gore, J. M. McCleery, Miss D. G. D'Abreu, A. F. Abbassi, E. S. Palmer, K. Ponniah, L. M. S. Parmanand, A. S. Westmorland, E. T. Saravanamuttu.

* With distinction.

Obituary.

THOMAS H. LIVINGSTONE, M.D., F.R.C.S. EDIN.,
Newcastle-on-Tyne.

THE death occurred on Christmas morning, at 38, Jesmond Road, Newcastle-on-Tyne, of Dr. Thomas Hillhouse Livingstone. He was the second son of the late Dr. Thomas Livingstone of Stanhope in Weardale, who was for over thirty years in practice at Stanhope, and who occupied a very prominent position in the public and social life of the dale. Dr. T. H. Livingstone was educated at Wolsingham Grammar School and Uppingham. He then proceeded to Edinburgh University, where he graduated M.B., Ch.B. in 1899. He filled the post of house surgeon at Rochdale Infirmary, and later carried on his father's practice at Stanhope with much acceptance till 1903. He then returned to Edinburgh for a period, and took the M.D. degree and F.R.C.S. Edin. diploma, afterwards settling in practice in Newcastle. He became an honorary surgeon to the Hospital for Sick Children, and retired from this position in 1912. He was then appointed surgeon to the Throat, Nose, and Ear Hospital, Newcastle. During later years he confined his work entirely to this special branch, to which he had always had a leaning, and in it he had the satisfaction of being able to do much good work. He held a commission in the Territorial Force, and was mobilized at the outbreak of the war. He was under orders to proceed to France when he became seriously ill, and was admitted to the 1st Northern General Hospital with the malady which eventually proved fatal. Partially recovering from this illness, he was attached to the ear and throat department of the 1st Northern General Hospital. In 1914 he was made a vice-president of the Ear, Nose, and Throat Section at the annual meeting of the British Medical Association at Aberdeen. By nature he was of a most refined and gentle disposition, a gentleman in the truest sense of the word. He was possessed in a marked degree of that innate courtesy and kindness to others which one likes to associate with the profession. He was greatly attached to his native dale, and occasional visits from Newcastle to his old home in the country always gave him the utmost pleasure. To his many friends both in Weardale and Newcastle his death at the early age of 43 has come as a great grief. His remains were interred in the old churchyard of Stanhope.

The Services.

TERRITORIAL DECORATION.

THE King has conferred the Territorial Decoration upon the following medical officers of the Territorial Force:

Lieutenant-Colonels A. W. Mackintosh, 1st Scottish General Hospital, and (Brevet Colonel) Alexander Napier, V.D., Honorary Surgeon-Colonel (Honorary Surgeon-Colonel ret'd. Vols.) 4th Scottish General Hospital (retired).

Majors J. F. Christie, attached 4th Battalion, Gordon Highlanders, A. C. Turner, D.S.O., attached 49th West Riding Divisional Engineers, E. L. Anderson, 2nd West Lancashire Field Ambulance, J. W. MacKenzie, O.B.E., 1st Highland Mounted Brigade Field Ambulance, A. H. Horsfall, D.S.O., attached Royal Herbert Hospital, Woolwich, and J. M. Bowie, attached 9th Battalion, Royal Scots.

Surgeon-Captain Shepherd McC. Boyd, 2nd Home Counties Brigade, R.F.A. (ret.).

DEATHS IN THE SERVICES.

Lieut.-Colonel Richard Henderson Castor, Madras Medical Service (ret.), died of pneumonia at Croydon on December 30th, 1920, aged 59. He was born on May 12th, 1861, the son of Captain John Castor, master mariner, of Cochin, took the M.R.C.S. and L.R.C.P. Lond. in 1884, and entered the I.M.S. as surgeon on September 30th, 1886. He served in the Burmah campaigns of 1887-89, receiving the frontier medal with a clasp, and in May, 1890, went into civil employ in Burmah, in which province he spent the remainder of his service (thirty years). He became lieutenant-colonel on September 30th, 1906, received extension of service for four years during the war, and retired on November 9th, 1920, only six weeks before his death. He received the Kaiser-i-Hind medal (1st class) on June 3rd, 1919.

Medical News.

THE Earl of Radnor has accepted the office of President of the Thirty-second Congress of the Royal Sanitary Institute, to be held at Folkestone from June 20th to 25th, 1921.

SIR JAMES KINGSTON FOWLER will deliver an address entitled "The Colonial Medical Service" at the Middlesex Hospital Medical School on Thursday, January 20th, at 3 p.m., when the Earl of Athlone will preside.

THE Medical Branch of the Board of Education has been transferred from Cleveland House, St. James's Square, S.W.1, to Bridgewater House, Cleveland Square, S.W.1 (telephone 3410 Gerrard).

WE have received from Dr. Ernest W. Jones, the Honorary Secretary, a copy of the programme of the newly formed Birmingham Medico-Psychological Society. The President is Lieut.-Colonel A. W. Moore. Meetings for the discussion of papers are held monthly on Wednesday afternoons.

DR. OLIVER K. WILLIAMSON, physician to the City of London Hospital for Diseases of the Chest, has been appointed Professor of Medicine in the Medical School of the University College, Johannesburg.

A PROPOSAL has been made to install new x-ray apparatus and equipment at the Bolingbroke Hospital, Wandsworth, as a memorial to the late Dr. Cecil Lister, whose early experiments with x-rays were carried out in that institution.

CAPTAIN W. E. ELLIOT, M.P., Dr. A. Mearns Fraser, Dr. Jane Lorimer Hawthorne, Surgeon Vice Admiral Sir James Porter, K.C.B., K.C.M.G., and Mr. A. H. Tubby, C.B., C.M.G., F.R.C.S., have recently joined the Executive Committee of the Society for the Prevention of Venereal Disease.

AT the meeting of the Medico-Legal Society to be held at 11, Chandos Street, W.1, on Tuesday, January 18th, at 8.30 p.m., Dr. H. Gibson Sutherland will read a paper on "Medical evidence in the Stanton murder trial."

A SPECIAL general meeting of the West London Medico-Chirurgical Society will take place in the society's rooms at the West London Hospital on Friday, January 14th, at 8.30 p.m., in order to discuss the Medical Consultative Council's interim report on the future provision of medical and allied services. Medical practitioners are cordially invited to attend and take part in the discussion.

COURSES of lectures on infant care, to be held in London and at Worcester, have been arranged by the National Association for the Prevention of Infant Mortality and for the Welfare of Infancy: an elementary course in London has been arranged by the association in conjunction with the National Society of Day Nurseries. Particulars may be obtained from Miss Halford, Secretary of the National Association for the Prevention of Infant Mortality, 4 and 5, Tavistock Square, London, W.C.1.

IN the Psychological Department, University of London, King's College, Strand, W.C.2, Dr. William Brown will give a course of ten lectures on psychopathology on Tuesdays, at 5.30 p.m., during the Lent term, commencing on Tuesday, January 18th. These lectures are open to medical students and medical practitioners without fee or ticket.

Letters, Notes, and Answers.

As, owing to printing difficulties, the JOURNAL must be sent to press earlier than hitherto, it is essential that communications intended for the current issue should be received by the first post on Tuesday, and reaching the printers on Monday.

ORIGINAL ARTICLES and LETTERS for publication are understood to be offered to the BRITISH MEDICAL JOURNAL alone unless the contrary be stated.

CORRESPONDENTS who wish notice to be taken of their communications should authenticate them with their names—of course not necessarily for publication.

AUTHORS desiring reprints of their articles published in the BRITISH MEDICAL JOURNAL are requested to communicate with the Office, 429, Strand, W.C.2, on receipt of proof.

In order to avoid delay, it is particularly requested that ALL letters on the editorial business of the JOURNAL be addressed to the Editor at the Office of the JOURNAL.

THE postal address of the BRITISH MEDICAL ASSOCIATION and BRITISH MEDICAL JOURNAL is 429, Strand, London, W.C.2. The telegraphic addresses are:

1. EDITOR OF THE BRITISH MEDICAL JOURNAL, *Actiology*, Westminster, London; telephone, 2630, Gerrard.
2. FINANCIAL SECRETARY AND BUSINESS MANAGER (Advertisements, etc.), *Articulate*, Westminster, London; telephone, 2630, Gerrard.
3. MEDICAL SECRETARY, *Medisera*, Westminster, London; telephone, 2630, Gerrard. The address of the Irish Office of the British Medical Association is 16, South Frederick Street, Dublin (telegrams: *Bacillus*, Dublin); telephone, 4737, Dublin, and of the Scottish Office, 6, Rutland Square, Edinburgh (telegrams: *Associate*, Edinburgh; telephone, 4351, Central).

QUERIES AND ANSWERS.

INCOME TAX.

"PUZZLED" asks: "Should dividends from war loan, which are income tax free, be included as assessable income or not?"

Our correspondent presumably refers to the tax-compounded 4 per cent. war loan issue. Interest thereon should not be "returned for assessment" on page 2 of the ordinary form of declaration, but should be included in any statement of total income at the gross equivalent of the net amount received—that is, at £r plus three-sevenths of £r. It will not be assessed to income tax if its precise nature is shown, and is not exempt from super-tax.

"R. P. R." has been applied to for payment of income tax assessed on him for the year 1915. Can he now claim to have the assessment adjusted?

The legal position is that the claim should have been made by April 5th, 1917, but we anticipate that objection would not be raised by the authorities to the claim being put forward now in view of our correspondent's absence on military service and of his statement of the actual income of the year made through Holt's Agency, which might reasonably be regarded as an intimation of claim. We suggest that he might write in this sense to the local inspector of taxes. As regards the annuity, a claim can be put in by the recipient on or before April 5th, 1921, in respect of the three years ending April 5th, 1920, but not as regards earlier periods.

LETTERS, NOTES, ETC.

ARTIFICIAL LIMBS.

CAPTAIN H. H. C. BARD, D.S.O., in the course of a letter which we have not space to print in full, writes:

Whilst welcoming your leading article on artificial limbs as a means of keeping this vital problem before the public eye, I regret that you should have brought either desirable or necessary to have introduced the personal factor in your reply. To say that we who are interested ourselves in the welfare of our comrades, are the dissatisfied, is absurd, if for no other reason than that we happen to be the highly satisfied who have tasted the joys of wearing an artificial limb worth having, and our only desire is that the same joys may be brought within the reach of each and all of the thousands of others who have suffered a similar affliction. Then, again, you represent that we hold a brief for one particular make of limb, as if we had some axe to grind. This is not only absurd, but a most unfortunate misrepresentation of our case. What we have asked for is an impartial committee, on which

limbless men themselves shall have a fair and reasonable representation, which shall investigate every phase of the problem of artificial limb supply. Also, as a further proof of our impartiality, it may interest you to know that we, the "mouthpieces of the dissatisfied," as you term us, are now, at the request of the Ministry of Pensions, putting their standardized light metal model to practical tests. But this impartiality on our side also looks for justice—or is it favour?—to all makers of artificial limbs, whether they belong to the British Association of Limb Makers or not. On this account we should expect the impartial committee, when set up, to investigate all that has passed between Messrs. Desoutter Brothers and the Ministry of Pensions during the last two years, and exactly how far Mr. Desoutter himself, the pioneer of light metal legs, with which type all other other makers are now experimenting, has been consulted in the development of the Government model. Such an investigation would throw a little light on to such matters as cost, methods, and delay; and exactly to what extent the interests of the wearers of artificial limbs, to say nothing of the taxpayers, have been studied in the past and how these can best be studied in the future. Presumably also this committee would investigate the results of the practical tests of light artificial legs carried out by the British Red Cross many months ago, which up to the present have never yet seen the light of day. In regard to the other points raised in your article relating to curvature of the spine and weight, etc., I do not propose to deal with these in detail. Obviously the only way of arriving at a true solution of this problem is not through the medium of leading articles or letters in the press, but by a thorough and unbiassed investigation of the practical experiences of wearers of artificial limbs themselves, such as we have asked for. No doubt you have concrete evidence in support of your statement that "it is certain that a very large number, and probably the great majority, of pensioners are well satisfied with the limbs supplied by the Ministry of Pensions, but they do not feel called upon to write to the daily papers and say so." All I ask is that your evidence may be placed alongside ours, together with that of any others whose evidence may be called. It will then be left to that committee, not to you nor to us, nor the limb-makers, nor the surgeons, nor the Ministry of Pensions, to decide in co-operation with limbless men themselves whether the present state of affairs is satisfactory or not; and whether it has been "disgruntlement" or "right" which has caused us to raise our voice.

TRIPLETS.

DR. H. WESSEN HUSBANDS (Taunton) writes: The following cases, which occurred in my practice last year, may possibly be of some interest to certain members of the profession from a statistical point of view. According to the authorities, triplets occur in about 1 in 7,000 to 10,000 labours: the children are generally small, poorly developed, and often do not survive their birth many days. In March I was called by the district nurse to Mrs. S., aged 27, first pregnancy. She was delivered of two girls and a boy.

Weight of first girl	6 lb.
" of second girl	6½ lb.
" of boy	3½ lb.

All are alive and doing well. In October I was called to Mrs. T., aged 37, seventh pregnancy. She was delivered of three boys.

Weight of first	8 lb.
" of second	7½ lb.
" of third	7 lb.

All are alive and doing well. Unfortunately in the last case the mother developed puerperal insanity at the end of the second week, and was removed to the asylum, where she died three weeks later. It certainly must be a rarity for one medical practitioner to have two cases of triplets in six months.

EMETINE IN BILHARZIASIS.

IN our issue of October 30th, 1920, Dr. Andrew Balfour, in response to an inquiry by Dr. Esser, of Rustenburg, Transvaal, gave a list of references to papers describing the use of emetine in bilharziasis. Dr. Balfour pointed out that the drug had been given a considerable trial, but questioned whether the evidence yet adduced warranted its substitution for antimony. He referred, among other writers, to Dr. Diamantis of Cairo, from whom we have received a letter dated December 4th, 1920. In the course of it he says that he was the first to employ a radical treatment of bilharziasis, by recommending emetine hydrochloride, by pointing out the indications for its use, and by stating the suitable dose. The value of the treatment has, he says, been proved, and the results are not to be despised; it is being used by many Egyptian practitioners every day. "There remains, however," Dr. Diamantis continues, "the question of the toxicity of emetine given intravenously. Is it really worth while, in order to treat bilharzial haematuria, to run the risk of producing the toxic effects of emetine given intravenously? In my earlier publications I stated clearly the indications for adopting this treatment, the dose which should be used, the accidents to be feared and the means of preventing them, and gave a detailed description of the technique. I have injected into the vein of an adult in one dose 0.12 gram of emetine; I have never had any untoward effects. . . . The

method of administration is within the competence of any practitioner who knows how to give an intravenous injection. I employ the ampoules of emetine as supplied by Clin, Burroughs Wellcome, or Parke Davis, without the addition of saline solution. It is not necessary to take the patients into hospital. My experience has satisfied me that ten to twelve injections, at intervals of three to five days, will suffice for the radical cure of the adult, the amount of emetine given being from 0.85 to 1.05." In reply to Dr. Esser, Dr. Diamantis states that he has had no experience of the intravenous injection of emetine in amoebic dysentery; bilharzial haematuria, he points out, is only a local affection, the general condition of the patient being satisfactory, whereas dysentery, being a general disease, the patient is in a bad condition, and the myocardium, suffering already from the poison of dysentery, is not in a condition to resist poisoning by emetine in addition. A great advantage in the treatment of bilharzia is, Dr. Diamantis considers, that it can be given by hypodermic injection as stated in a communication made by him to the Institut Egyptien in 1916. Dr. Diamantis goes on to note—that he considers the remarkable fact—that tartar emetic has an effect not only in bilharziasis, but also in kala-azar, which is a leishmaniasis, and that emetine acts not only in bilharziasis, but also, as observed by Dr. Photinos of Athens, when injected locally in oriental sore, which again is a leishmaniasis.

DR. ESSER writes from Rustenburg, Transvaal, under date November 26th, 1920, to thank Dr. Balfour for his reply. Intramuscular injection, while a much simpler procedure than intravenous, must, Dr. Esser points out, be done with strict aseptic precautions to avoid the risk of abscess, and as emetine is poisonous and has a cumulative action, it is important not to give more than is absolutely necessary to cure. The advantages of the intravenous route are, in Dr. Esser's view: (1) That the pain, swelling, and discomfort, which often follow subcutaneous or intramuscular injection of emetine, are absent or very slight; (2) a smaller quantity of the drug will be needed. He thinks that the intravenous, being the more direct route, will prove the more effective and certain method of cure. Facilities can hardly, he says, anywhere be lacking for making a little normal saline solution, boiling it, and dissolving in it one or more tablets of emetine. At the same time he suggests the use of the sealed glass tubes (such as the ampoules mentioned by Dr. Diamantis).

ONE WAY OF SELECTING A HEALTH RESORT.

DR. JOHNSON SMYTH (Bournemouth) sends us the following note: A patient, 60 years of age, informed me he had decided on permanently residing in Bournemouth. He gave as his reason that since retirement he has spent considerable time in visiting the graveyards from Deal to Land's End, and he made the remarkable discovery that he found on the tombstone records a far higher percentage of persons dying at 81 and over in Bournemouth than elsewhere. "That's good enough for me" was his final remark.

CORRECTION.

DR. G. C. GARRATT's letter last week (p. 31, col. 1) contains two errors which were uncorrected because time did not allow us to send him a proof. The word "discussion" in line 14 should be "dissension" and "War Pensions Committees" should be substituted for "county councils" in the 12th and 13th lines from the foot of the column.

VACANCIES.

NOTIFICATIONS of offices vacant in universities, medical colleges, and of vacant resident and other appointments at hospitals, will be found at pages 33, 34, 36, 37, 38, and 39 of our advertisement columns, and advertisements as to partnerships, assistantships, and locum tenencies at pages 35 and 36.

THE following appointments of certifying factory surgeons are vacant: Dalmeington (Ayr), Fishguard (Pembrokeshire).

SCALE OF CHARGES FOR ADVERTISEMENTS IN THE BRITISH MEDICAL JOURNAL.

	£	s.	d.
Six lines and under	0	9	0
Each additional line... ..	0	1	6
Whole single column (three columns to page) 7 10 0	7	10	0
Half single column	3	15	0
Half page	10	0	0
Whole page	20	0	0

An average line contains six words.

All remittances by Post Office Orders must be made payable to the British Medical Association at the General Post Office, London. No responsibility will be accepted for any such remittance not so safeguarded.

Advertisements should be delivered, addressed to the Manager, 429, Strand, London, not later than the first post on Tuesday morning preceding publication, and, if not paid for at the time, should be accompanied by a reference.

NOTE.—It is against the rules of the Post Office to receive *post-restante* letters addressed either in initials or numbers.

An Address

ON

THE PART OF THE PRACTITIONER IN THE TREATMENT OF THE PRE-OPERATIVE STAGE OF ENLARGED PROSTATE.

BY

J. W. THOMSON WALKER, M.B., F.R.C.S.,

SENIOR UROLOGIST AND LECTURER ON UROLOGY, KING'S COLLEGE HOSPITAL; SURGEON TO ST. PETER'S HOSPITAL.

In surgery it is always easy to be wise after the event. Prostatic surgery supplies us with many examples of this truth, and anyone who thinks out the cause of post-operative disappointments and failures must at times regret that more care was not taken in pre-operative treatment.

The greater the experience I gain in prostatectomy the more I am impressed by the fact that many of the complications of prostatectomy are preventable by pre-operative treatment. There are complications against which no provision can give immunity. We cannot, for instance, avoid the occurrence of pulmonary embolism in a practically clean case. We cannot avoid cardiac failure which occurs days or weeks after the operation, or renal failure where the kidneys have been destroyed beyond the point of recovery. But we can prevent or modify some of the bowel complications or kidney complications and some of the other complications by careful pre-operative examination and preliminary treatment. And it is along these lines that the practitioner can do so much to help in reducing the mortality of prostatic enlargement.

The risks to which a patient suffering from enlarged prostate, whether he be submitted to operation or treated without operation, is exposed, are not confined entirely to the urinary organs. They may be arranged for discussion under different systems:

1. Gastro-intestinal risks.
2. Pulmonary risks.
3. Circulatory risks.
4. Nervous system risks.
5. Urinary risks.

GASTRO-INTESTINAL RISKS.

I will first relate a case of gastro-intestinal complication following operation, and then discuss the subject.

A. S. B., aged 60, complained of frequent micturition and neuritis of the right arm. He was known to have a high blood pressure (180), and had had his teeth removed as a possible source of infection for his neuritis. There had been several attacks of retention of urine during the past two years.

He was a stout, short-necked man with a predominant abdomen. The frequency of micturition amounted to twenty minutes during the day and five or six times at night. There was urgency, hesitation at the commencement and difficulty in the act. The urine was clear, and there was about one ounce of residual urine. The urine contained only 1 per cent. of urea, but the quantity was normal. The prostate was large, elastic, movable and prominent in the rectum. The kidneys were not palpable & tender. He showed no clinical signs of uraemia. His appetite was large, and there was a tendency to constipation. Flatulent distension of the abdomen was common after meals. Apart from the enlarged prostate, bowel distension, the high blood pressure and the low urea content of the urine, nothing abnormal was discovered by two physicians at different dates.

I was uneasy about the bowel, and declined to operate until he had undergone some treatment for the flatulent distension. He improved on bowel antiseptics, but pituitary gland did not suit him. After a month I saw him again and consented to operate, although I expressed some anxiety in regard to his bowel.

On June 10th, 1920, an adenomatous prostate weighing 56 grams was removed under spinal anaesthesia with a minimal amount of general anaesthetic. Haemorrhage was very moderate, and there was no shock. Post-anaesthetic vomiting was moderate on the day of the operation, and had ceased next day. On June 11th the condition was good and much flatus was passed. The temperature was 99°. There was free drainage, the urine being stained with blood. During the day he complained of flatulence; pituitrin (2 c.cm.) gave much relief, and flatus was passed freely.

During the night June 11th-12th flatulence was very troublesome, but was relieved by the rectal tube. The temperature was 99° and the pulse 80. The complaint of flatulence continued on June 12th and 13th, but on the 14th it had disappeared and on this day the bowels moved three times after an aperient.

* Part of an address delivered before the Brighton and Sussex Medico-Chirurgical Society on December 2nd, 1920.

On June 20th he was given some indigestible food by his relations. This was followed by vomiting and abdominal distension. These symptoms continued and now dominated the clinical picture. Urine was being secreted in good quantity. On June 20th he was seen by a physician, who diagnosed intestinal obstruction, and a general surgeon was called in consultation. The surgeon, however, agreed with me that there was no obstruction or peritonitis. Vomiting continued. The stomach was washed out, with some relief.

During the next ten days the distension varied; sometimes the abdomen was tense and at other times it was fairly soft. The bowels were opened by enemata with varying results, the motions being always very offensive.

On June 26th, 27th, and 29th the temperature rose to 100° and 101°. The quantity of urine, so far as could be measured, diminished slightly, but it was 57 oz. on the 28th and 58 oz. on the 29th.

On June 25th the blood urea was examined and found to be greatly increased (370 mg. in 100 c.cm.). There were no symptoms pointing to uraemia on June 27th, but next day there was some drowsiness and a good deal of wandering. On this day (June 28th) signs of cardiac failure appeared and became increasingly evident, and recurred during June 29th, and he died on June 30th.

I have quoted this case at length as it is a good example of the type of bowel complication that is likely to be met with after prostatectomy. In this case there was an element of uraemia (due to chronic interstitial nephritis), which is absent from most of the cases I have seen.

Post-operative distension of the bowel may occur in all degrees of severity, from a slight flatulent distension with difficulty in getting the bowels moved for a few days after the operation to a prolonged distension of the bowel ending fatally from pressure on the diaphragm and interference with the heart's action. Rarely it occurs as a very acute condition and is rapidly fatal.

One of the most striking cases I have seen occurred in a man of 60 of the same type as the last, in whom I removed the prostate and a bladder growth. He made good progress until the fourth day, when he suddenly had pain in the epigastrium; the abdomen became acutely distended and the distension continued for two hours, when he died of cardiac failure. I have not seen another case so acute.

This post-operative distension in urinary surgery is not confined to prostatic and bladder cases. I have seen a similar condition which ended fatally after an operation for stone in the kidney, and distension of the colon is not uncommon during the first few days after kidney operations. It is seldom, however, that it is so serious as that following prostatectomy. I have seen it also in a case of septic stone in the kidney where no operation was performed.

In looking for a cause for the condition we must remember that in kidney operations the colon is stripped from its attachment to the kidney and below this, and there is sometimes a good deal of trouble in separating adhesions at the extraperitoneal aspect of the colon. When we remember also that in septic kidney conditions perinephritis is constantly present, and that this must involve the contiguous wall of the colon, there is no difficulty in recognizing that a local paralysis of the colon is likely to occur leading to distension with datus which spreads to other parts of the colon.

In prostatic cases so simple an explanation is not possible. In most of those I have seen the colon is distended, and constipation and hicough are frequent, but in some cases the stomach is the organ affected, and the distension affects the upper part of the abdomen; in these constant vomiting of coffee-ground material is usually a symptom, and a large quantity of this fluid may be removed with the stomach tube.

Most of these cases are cases of enlarged prostate with back pressure on the kidneys, and in some of them, such as that which I have described, uraemic symptoms actually appear. It is likely, therefore, that uraemia may have something to do with causing the condition. But there are cases that occur in younger men without sepsis or back pressure, and, further, the symptoms and proof of renal inadequacy is absent in most of the cases.

Two elements, I believe, enter into the causation. One is flatulent distension of the bowel from intestinal fermentation, and the other is exhaustion of the sympathetic nervous system as a result of uraemia, intestinal toxæmia, or shock.

Recently it has been suggested that post-operative dilatation of the stomach is due to dragging on the

mesentery by the small intestine dropping into the pelvis after the removal of large pelvic tumours (Borchgrevink).

Having recognized that such a condition may complicate prostatectomy, is it possible to forestall its occurrence and do something to prevent it? It is, I believe, possible to do so.

There are two different types of patient that are liable to this condition—a thin type and a stout type. Imagine a thin man of 60 with a sallow complexion. He complains of prostatic symptoms; the prostate is enlarged, and there is a varying amount of residual urine. Further investigation shows that he suffers from flatulent indigestion after meals, and has to be careful about his diet; his teeth are probably decayed and there is pyorrhoea; the tongue is coated. The abdominal wall is thin, and should lend itself to easy palpation but that the bowel is full of gas, the percussion note tympanic, and abdominal palpation is difficult. The other type is a stout, flabby man of 50 or 60, often of the Jewish race. He is fond of rich fatty foods, and is immoderate in his indulgence in them. The abdomen is prominent, rounded, and tense; there is no pyorrhoea or decayed teeth. When you meet with an enlarged prostate with either of these types you may expect post-operative trouble from the bowel.

How can we prevent this complication and how treat it when it occurs?

In all such patients I recommend a course of four or five weeks' bowel treatment after the teeth have been carefully overhauled. This question of teeth is very important; it affects not only the bowel risks, but also the pulmonary risk. Oral sepsis is the cause in some degree, if not wholly, of the flatulent dyspepsia of the first type of case. It may take five or six weeks or even longer for the dentist to treat the oral sepsis, and there may be considerable difficulty in getting the patient to consent to the dental treatment, but the matter is so important that it is the duty of the doctor to insist on the mouth being clean before any operation is performed. Anaesthetists will, I think, support me when I complain of the condition of the mouth and teeth in many patients who come up for operation, not only in hospital but in private practice. I do not think that practitioners sufficiently appreciate the serious menace that such a condition is to a patient about to undergo an operation.

All these intestinal-risk patients, however, do not have decayed teeth and pyorrhoea and the second type very often have good teeth. The bowel itself must therefore be treated.

I do not presume to instruct such an assembly as this in the treatment of flatulent dyspepsia. Let me mention, however, the lines of treatment that have been most successful in the prostatic cases I have seen. They are the restriction of starchy foods and green vegetables in the diet, bowel antiseptic treatment, and bowel tonic treatment. A capsule containing β -naphthol 5 grains, salol 5 grains, and calomel $\frac{1}{2}$ grain has proved a good combination, and capsules of kerol (intestinal) are very valuable. At the same time the bowels must be regulated by vegetable aperients. I do not consider salts and aperient waters suitable for these cases, for they tend to cause distension of the bowel with gas. Tonic treatment of the bowel should be combined with these measures. Strychnine and ergot are the best drugs, and suprarenal and pituitary extracts act as powerful tonics of the bowel muscle.

Two other methods of treatment have been of much use in these cases—namely, abdominal massage and electrical treatment of the bowel. One would, of course, not think of employing either of these methods where the bladder is known to be distended with residual urine.

Now let us turn to the post-operative treatment. In the average patient the immediate preparation of the bowel for operation consists in giving a dose of castor oil two nights before the operation and washing out the colon on the morning of the operation. After the operation the bowel is left quiet for three or four days, and then a dose of castor oil is given. This is done in order to avoid straining after the operation, which sometimes causes bleeding.

If, after the operation, the patient commences to show distension of the abdomen or vomiting of dark coffee-ground material, a purge (castor oil) must be given at once.

In some cases the stomach is distended and there is

persistent vomiting. Here the stomach tube should be passed, and the stomach washed out. Sometimes large quantities of dark brown fluid are removed and the washing will have to be repeated.

Borchgrevink, who looks upon dilatation of the stomach after abdominal operations as due to dragging on the mesentery causing obstruction at the duodeno-jejunal junction, recommends the prone position and elevation of the pelvis; and operation has been recommended with the object of raising the intestines from the pelvis and relieving the drag on the mesentery, and also of removing adhesions. I have not met with a case of post-prostatectomy distension where this procedure held out any prospect of success.

The more common cases have distension of the colon and hiccough, but no vomiting. Pituitary gland is a good drug in these cases, but it should be given carefully on account of its effect on the blood pressure; $\frac{1}{2}$ c.c.m. may be given at first and repeated in a few hours, and 1 c.c.m. given daily. Ergot and strychnine may also be given.

A high rectal tube should be passed and the colon washed out and a tube left for several hours at a time in the rectum. When the patient is stout, he should be made to lie on his side instead of being propped up in a sitting position, as the passage of flatus is facilitated by this position. Various enemata are given—soap and water, os-gall, turpentine. Care is necessary in giving enemata of turpentine in old feeble patients. In a hospital patient I once saw sloughing of the whole thickness of the rectal wall in a circular cuff following a large turpentine enema.

PULMONARY RISKS.

There are two pulmonary risks that should engage the attention of the practitioner before the operation. One is the possibility of post-operative pneumonia and the other is bronchitis.

Most cases of post-operative pneumonia that I have seen when the patient has not been exposed for a long period at the operation were due to septic teeth, or to some septic condition of the nasal sinuses. These sources of septic pneumonia should be most carefully treated before the operation of prostatectomy is undertaken. It is sometimes urged that the operation is urgent and must be done without delay. There is nothing to support this view. It may be, and often is, urgently necessary to drain the bladder on account of sepsis or obstruction, but this can be done under local anaesthesia and the prostatectomy deferred until the patient has got rid of the oral or nasal sepsis.

Chronic bronchitis requires careful pre-operative treatment. A patient with bronchitis after prostatectomy, or, indeed, after any abdominal operation, is in a very serious state. Coughing is very painful and difficult, and the patient is apt, even in the sitting posture, to become water-logged from inability to expectorate. Pre-operative treatment may include courses of vaccine and even climatic treatment before the patient is fit for operation.

Chronic bronchitis is not infrequently combined with obesity and a fatty heart, and those patients are very grave risks for prostatectomy. Certain modifications of the operation should be made in order to lessen the risk in these patients. Spinal anaesthesia is used as an anaesthetic, the Trendelenburg position is avoided, and the patient is kept sitting up in bed after the operation.

I have tried prostatectomy under local anaesthesia in such cases, but have not been favourably impressed by the method. Cystotomy is easily carried out under local anaesthesia without the patient suffering pain or even discomfort, but I have found that even the most careful preparation of the bladder, urethra, and prostate with local anaesthetics is not sufficient to abolish the pain of enucleating the prostate, tearing across the urethra, and removing the gland from its bed.

Pronounced spinal curvature, whether due to old spinal caries or to other causes, is a grave pulmonary risk. One of the greatest risks I have taken, and one which I am glad to say was justified by success, was the case of a well-known member of our profession who suffered from advanced osteitis deformans, and in whom the spinal curvature was so extreme that the ribs met the iliac crests on each side. The chest was rigid, and respiration was purely diaphragmatic. Yet he underwent a severe operation for growth of the bladder, and lived without recurrence for some years afterwards.

CIRCULATORY RISKS.

Circulatory risks are probably the most difficult of any to estimate where prostatectomy is proposed. There are some that are much reduced by careful treatment. Two of these deserve mention—namely, high blood pressure and cardiac insufficiency. With high blood pressure we expect post-operative hæmorrhage. These patients usually stand hæmorrhage very well, but a hæmorrhage severe enough to cause a sudden drop of blood pressure may end fatally. Any hope of permanently reducing the blood pressure before operation is certain to lead to disappointment, but much can be done by rest, careful diet, removal of stimulants, and attention to the bowel, and a careful course of such treatment for a month before operation will well repay the time spent. I recently operated on a patient when the blood pressure was the most important factor in the case. The case was as follows:

A gentleman, aged 62, consulted me in October, 1920. He complained of frequent micturition night and day. There were recurrent attacks of difficult micturition, during which there was spasm of the bladder and severe straining. He had been catheterized, and this had been followed by a rise of temperature. The urine contained a small amount of mucus and very many micro-organisms. The blood pressure was 190 to 200 mm. Hg. In January, 1919, he had a slight attack of hemiplegia. The intensity of the spasmodic attacks suggested the possibility of some cord lesion.

He was a spare active man with a moderate enlargement of the prostate and no residual urine, suitable for prostatectomy, but with circulatory and nervous risks. Sir Thomas Horder examined him and reported that there were no signs of cord changes, but that definite traces of left hemiplegia still remained. The blood pressure was high, but Sir Thomas Horder agreed with me that there was a circulatory risk in not operating from the severe straining during the recurrent attacks of obstruction.

Operation was decided upon, and the following points were made in regard to the anaesthetic: Gas and oxygen and also ether were avoided on account of the effect on the blood pressure. The Trendelenburg position was precluded from the effect it would have on the cerebral circulation. The anaesthetic chosen was spinal anaesthesia with stovaine.

The operation passed off smoothly. There was one small hæmorrhage after the operation, but it was easily controlled. The patient made a good recovery.

I have operated on patients suffering from the various forms of valvular disease of the heart, and also in a case of thoracic aneurysm, and have not had any trouble so long as compensation was good. If the patient can walk quickly and go upstairs without breathlessness, and can go about his ordinary duties without cardiac pain or other sign, there is apparently nothing in a valvular lesion to contraindicate prostatectomy.

When the blood pressure is high ether is better avoided, and in most cardiac lesions the Trendelenburg position should be avoided as far as possible. Spinal anaesthesia, with a very small amount of C.E. and oxygen, seem to suit these patients. In choosing the anaesthetic, the profound drop in the blood pressure, as the result of spinal anaesthesia, will of course be taken into consideration.

Anæmia is a further risk. The risk is partly operative and partly post-operative. These patients do not stand loss of blood at the time of the operation, and they are less likely to survive post-operative complications, such as bronchitis, bowel distension, exacerbation of pre-existing sepsis, etc. Moreover, they heal very badly. The wound fills with weak oedematous granulation. Closure of the bladder is delayed and a fistula may persist.

Brandsford-Lewis, in discussing the importance of anaemia in prostatectomy, states that hæmoglobin, about 60 per cent., is favourable, 50 per cent. justifiable, 40 per cent. is unfavourable, and 30 per cent. fatal in prostatectomy. Without making any such hard-and-fast rule, I feel that there should be very careful consideration of this risk before operation, and that treatment should be directed to removing it.

Anæmia in these cases usually results from chronic sepsis, and the treatment must be directed primarily to removing this. In the great majority of cases the sepsis is in the urinary tract, and the patient is suffering from what is termed urinary septicaemia—a combination of raemia from obstruction and toxæmia from chronic cystitis and pyelitis or pyelonephritis. In such cases the proper treatment is free drainage of the bladder by cystotomy. The removal of the prostate is postponed until the sepsis has cleared up and the hæmoglobin content of the blood has improved. A two-stage operation is thus carried out.

Treatment of extra-urinary sources of sepsis should also be carried out. Alveolar abscesses, pyorrhoea, septic tonsils, sepsis of the accessory air passages, chronic appendicitis, cholecystitis, are some of these extra-urinary foci of sepsis that require treatment before prostatectomy is undertaken. Further direct treatment of the anaemia should be undertaken. The question of transfusion of blood should, I think, be raised in these cases, and I am strongly of opinion that in selected cases this should be carried out before undertaking prostatectomy.

NERVOUS SYSTEM RISKS.

The question occasionally arises whether a patient suffering from tabes or multiple sclerosis should have an enlarged prostate removed.

The diagnosis is extremely difficult. There is an adenomatous enlargement of the prostate and signs of tabes. The point that at once arises is, what is the condition of the bladder wall? Is the residual urine that is present due to atony of the bladder wall or is it due to prostatic obstruction?

The following points are of importance in differentiating between nerve atony and obstruction. In atony of the bladder from nervous disease nocturnal incontinence is an early symptom. It appears sometimes before the other symptoms of nervous disease are noticed, and it should be a rule that whenever an adult male complains of nocturnal incontinence without other symptoms, tabes should be suspected, and a careful examination of the nervous system, including of course examination of the spinal fluid, made.

Incontinence of urine occurs, of course, in enlarged prostate, but not unless the bladder is distended and the leaking urine is an overflow. In tabes, on the other hand incontinence occurs where only a few ounces of residual urine are present.

In enlarged prostate frequency of micturition is a prominent symptom, especially nocturnal frequency. This is often absent in tabes and there may be a lack of desire rather than increased frequency. Where cystitis is present, however, there will be frequent micturition in tabes.

The time of onset of bladder symptoms may have been before the prostatic age—namely, after 50 years.

On passing a catheter, the force of the stream through the catheter is much more powerful in enlarged prostate than it is in tabes.

Cystoscopy shows changes in the bladder in tabes that are quite typical of the "nerve bladder." The whole bladder wall is covered with thin, sharp trabeculae, crossing and recrossing each other, and between these are multitudes of sacculi. The trigone is not affected.

In the obstructed bladder the trabeculae are thick and fleshy, and sacculi only appear in the late stage, and are comparatively few in number. The trigone is involved in the trabeculation, and it may be difficult to recognize the interureteric bar and find the ureters. In multiple sclerosis the symptoms are those of a spasmodic bladder, and the diagnosis is more likely to be confused with cystitis. There is frequent micturition amounting to strangury, active incontinence at night, and sometimes also during the day, no residual urine, and the urine is clear.

When in a tabetic subject the residual urine is due to enlarged prostate, prostatectomy will give a brilliant result. In such a case there is a danger of bedsores developing during convalescence, but this can be avoided by careful nursing. I have performed prostatectomy three times on patients the subject of advanced disease of the spinal cord—twice in tabes and once in multiple sclerosis—and in all with success, the vesical function being completely restored to its normal condition.

Another problem connected with the nervous system is operation on patients suffering from enlargement of the prostate who have had hemiplegia. This problem is connected also with the circulatory system, and I have discussed it under that system.

URINARY RISKS.

Of all the risks to which the sufferer from enlargement of the prostate is exposed, those connected with the urinary tract are the most common, and also the most frequently fatal. These risks are, however, the most amenable to pre-operative treatment. They are sepsis and renal inefficiency.

A very large number of the patients that come to the surgeon are already infected and are suffering from the effects of back pressure on the kidneys. They are passing through a danger period which may be of recent onset or may have existed for some months or even years. Operation on such patients frequently gives very brilliant results. Patients who are broken down in health, unable to attend to their business or social duties, may, after prostatectomy, make a striking recovery and return to their duties active and rejuvenated.

But there is another side to the picture. The mortality in such cases is high. Some of these patients die under treatment before an operation is performed, others die from the operation because it increases the septic absorption or overturns the already much disturbed balance of renal secretion, and others, again, while temporarily improved by operation, gradually go downhill from the continued sepsis and progressive renal failure. It may be said, therefore, of cases of enlarged prostate suffering from sepsis and renal failure that the condition of the patient is very grave and will eventually be fatal without operation, that the mortality of operation in such cases is high, and that the duration of life in most cases that survive operation is shortened.

Is it necessary that patients should be allowed to pass through this period of danger before being relieved by operation? I hold that it is not, and I think most surgeons who do much prostatic work will agree with me that operation should be performed early in order to avoid this period of danger and its after-effects.

The remedy lies almost solely in the hands of the general practitioners. If they bring the patient up for operation in the early stage, before the bladder has been infected by the catheter and before the kidneys have been injured by the continued back pressure, this danger period can be avoided. There are, of course, some patients who refuse to submit to operation until they are convinced by the sufferings entailed by catheter life that it is inevitable.

The result of the operation in an early case is not so striking as in a case where the patient has suffered from urinary septicaemia, but after operation his prospect of life is better than even the most brilliant case of recovery from urinary septicaemia.

The practitioner should be prepared to make a diagnosis of enlarged prostate before an attack of retention has occurred.

Frequency of micturition is usually the earliest symptom. It may be the only symptom even when the prostate has reached a considerable size. There is a curious belief prevalent among the male public that increased frequency of micturition and nocturnal frequency is a normal accompaniment of advancing years. Nothing could be more erroneous. The senile bladder is, if anything, less sensitive than the young bladder, and any persistent increase in the frequency of micturition, nocturnal or diurnal, is pathological, and requires careful investigation.

Rectal examination may disclose, even in the early stage of the symptoms, a large elastic prostate. On the other hand, there may be a doubt as to whether enlargement is present. In such a case we must remember that the prostate enlarges in two directions—namely, outside the bladder, extending backwards into the rectum, and upwards into the bladder. There may be intravesical enlargement with very little change that can be detected *per rectum*. The next step, therefore, is cystoscopy, and at the same time an estimate will be made of the residual urine.

Where difficult micturition is the chief symptom, the degree of obstruction varies with wide limits, and I can best discuss it by giving three types.

TYPE 1.—*The patient with chronic retention of urine and partial renal failure, or uraemia.*

The patient can pass water with a fair stream, but he has pronounced nocturnal frequency and sometimes nocturnal incontinence. He usually complains of headache and thirst, and sometimes the latter is a prominent symptom. The tongue is dry and glazed, the appetite poor, and the bowels constipated. The patient may be losing flesh, but he sometimes says he is getting stouter, the fact being that the distended bladder increases his girth. On examination there is a distended bladder reaching

almost to the umbilicus. On rectal examination the prostate is enlarged and elastic. There is no more dangerous class of case in urinary surgery than this. A careful survey of all the symptoms is called for in order to estimate fully the probable danger points under treatment.

Finally, the condition of the kidneys should be carefully investigated. I have already indicated the symptoms of renal failure or uraemia. One of the tests of the renal function should be added to make the picture complete.

The most easily applied of these tests is called the urea concentration (MacLean) or forced urea elimination test, and there is no reason why the test should not be used by every practitioner. A dose of 15 grams of urea is given by the mouth, and the patient at the same time directed to empty the bladder as far as he can. The urine passed in the first hour is collected as a specimen, and that passed in the second hour after administration of the urea is collected. The urea is quantitatively estimated by the ordinary method. The normal kidney will excrete 2 per cent. or over, a damaged kidney between 1 and 2 per cent., and a seriously damaged kidney under 1 per cent.

I will pass now to the treatment of such cases.

The two cardinal points in the management of such a case are to avoid infecting the bladder and to empty the bladder very slowly. A distended bladder is much more easily infected than a normal bladder, and the slightest mistake in technique will be followed by some cystitis, which in such cases quickly leads to ascending pyelonephritis and death. When there is chronic distension of the bladder the kidneys are working against very high pressure. If the bladder is rapidly emptied, the sudden fall of pressure leads to a rush of blood into the renal vessels and suppression of urine very often supervenes.

Such are the dangers. How can they be avoided?

In the first place, there must be no hurry to pass a catheter without adequate preparation. The condition has been going on for many months, if not for years, and a few days longer will make no material difference. Therefore, put the patient to bed, keep him warm, get the bowels well cleaned out, give him urotropin and as much fluid as he will drink.

After a few days, under the most rigid aseptic precautions, pass a coude catheter, No. 8 or 10, and tie it in the urethra. Withdraw 10 oz. and plug the catheter. Get the nurse, very carefully drilled in asepsis, to withdraw 10 oz. every hour until the bladder is empty. Now attach a small rubber tube to the catheter and allow the urine to drain away continuously into a bottle. All the time continue the urotropin and large quantities of fluid and keep his skin acting by a warm temperature and hot bottles.

The danger period lasts usually a week or ten days, and during that time continuous drainage of the bladder must be kept up. One or two tests of the renal function during this period will show the functional condition of the kidneys. The clinical symptoms are a very important indication also.

With improvement the thirst diminishes and is lost, the tongue becomes moist, the appetite improves, and the headache disappears. On the other hand, persistence or increase of these symptoms is a grave indication. To these may be added drowsiness during the day and wandering and restlessness at night. The patient tries to get out of bed.

At the end of ten days or a fortnight what is to be done? If the patient has improved under the drainage, and the renal symptoms have disappeared, operation may be undertaken. If the renal symptoms have continued and increased, the bladder should be drained suprapubically under local anaesthesia, or gas and oxygen, and the patient must wait until the renal function has improved before the prostate is removed. It is sometimes necessary to wait for many weeks or even months before the patient is ready for prostatectomy. If the period is prolonged, a suprapubic apparatus should be fitted and the patient allowed to go about.

It will sometimes happen that the facilities for carrying out this programme of draining the bladder are lacking. In this case, and unless you are absolutely satisfied that you can conduct the case with safety from sepsis, it is far better to place the patient under the surgeon at once without passing any instruments at all.

TYPE 2.—*The patient with frequent micturition, difficultly, and a well-marked enlargement of the prostate, and about 6 oz. or 8 oz. of residual urine.*

It is obvious that an operation will have to be done or catheter life commenced. In such a case the decision should not be left until an attack of retention has occurred. The danger of the catheter, whether it is passed as an emergency for the relief of an attack of retention or whether it is used regularly to remove residual urine, is that sepsis is inevitable. The result of introduction of bacteria is cystitis, and this is immediately followed by ascending pyelonephritis or surgical kidney.

After ten or fourteen days the attack usually subsides, but the urine remains cloudy. Recurrent attacks occur after fatigue, constipation, exposure to cold, dietetic indiscretion, and such causes, and it becomes apparent that the patient is gradually going downhill. The condition that we know as urinary septicaemia is developing.

In the great majority of patients on catheter life, whether they suffer from urinary septicaemia or not, there comes a time when, from increasing difficulty in passing the catheter or from haemorrhage or pain in passing it, catheterization is no longer possible and an operation must be done.

I have already stated my view that patients should never be allowed to get into this condition, and that early operation should be performed in order to avoid it. If infection has already occurred and urinary septicaemia has developed, the first aim of treatment should be to get rid of the combined back pressure and sepsis. This is done by draining the bladder.

A suprapubic cystotomy is performed under local anaesthesia or under gas and oxygen, and the patient is given large quantities of fluids and hexamine or salol. Rectal administration of saline may be necessary, for the patient may be unable to take sufficient fluid by the mouth. At the same time the bladder is flushed by constant irrigation through a catheter tied in the urethra and a Hamilton Irving suprapubic box.

Removal of the prostate is deferred until the urine is sufficiently clear and the tests of the renal function are satisfactory and the symptoms of uraemia and sepsis have disappeared.

TYPE 3.—*The patient complains of a little difficulty in starting micturition, and may get up several times at night. The prostate is found to be very large and elastic. There may be little residual urine.*

In this class of case the patient has difficulty in realizing that an operation is necessary. He objects, as he puts it, to having an operation done when he is quite well. He is, however, in a dangerous position. At any time, from slight causes, such as fatigue, chill, etc., he may have an attack of retention, necessitating the passage of a catheter under difficult conditions, with the possibility of septic infection, or he may gradually develop the condition of chronic retention of urine, with back pressure effects in the kidneys, that I have described. These issues should be clearly placed before him and an operation recommended to prevent them.

There is another outcome which you do not hear very much about. An adenomatous prostate occasionally becomes malignant. There are, I find, two types of malignant prostate with which we have to deal. In the one the prostate is hard, nodular, and fixed, and the change has evidently been malignant from the commencement; in the other there is an elastic adenomatous prostate, which at one part is hard and leathery and becoming fixed. Further, there are some cases in which an enlarged prostate, adenomatous on rectal palpation, shells out easily and completely, but the pathologist reports that at one part in the gland the appearances are those of a malignant growth.

This malignant development does not take place in a large percentage of cases, but it is met with sufficiently often to make it necessary to consider it in estimating the prognosis of a case of enlarged prostate treated without operation.

INDICATIONS FOR OPERATION.

In discussing the question of operation as opposed to catheter life with your patients, I would like you to consider the following points:

1. Enlargement of the prostate is a progressive disease, the rate of increase of which we cannot foretell.
2. As the prostate enlarges, the patient grows older, and is less able to withstand the effect of uraemia or sepsis, or the effects of a severe operation.
3. When the symptoms become acute, much damage has already been done to the kidneys; and although improvement may follow operation, much of the damage is permanent.
4. Some adenomatous prostates become malignant.
5. The mortality of catheter life is higher than that of prostatectomy.
6. A very large proportion of the cases of enlarged prostate treated by catheter are forced eventually to undergo operation.
7. The prognosis in such cases is much graver than if the operation had been performed without a period of catheter life.
8. A large proportion of the deaths after prostatectomy are due to the sepsis caused by pre-operative catheterization or the back pressure and renal inefficiency due to delay in submitting to operation.

THE TEACHING AND STUDY OF HUMAN ANATOMY.

BY

RICHARD J. A. BERRY, M.D., F.R.C.S.,
F.R.S. EDIN.,

PROFESSOR OF ANATOMY, INCLUDING HISTOLOGY, IN THE
UNIVERSITY OF MELBOURNE.

CONTRARY to currently accepted opinion, human anatomy is not a study of the dead, but of the living. It merely utilises the dead as a partial and imperfect means to an end. That end seeks to establish the essential foundations upon which the practice of medicine is based, and hence the place of anatomy in the medical curriculum. It is not a thing apart from the curriculum, but belongs to every part of it. Anatomy also endeavours to promulgate the welfare of peoples by the study and interpretation of the biological laws of life. The former is the particular province of the student of medicine and the surgeon, whilst the latter belongs more exclusively to the professional anatomist. It should, however, be the aim of both to correlate the study of life with that of disease, and hence anatomy, as a part of the medical curriculum, should lead up to the study of medicine and surgery. If anatomy fails in either or both of these objects it can hardly expect either the recognition or the prominence in our curricula to which it is really entitled.

That anatomy has too long been regarded and treated as a study of the dead is only too probable. Its textbooks and teachings still reflect the multiplicity of detail of the mid-Victorian period, but do so in an even more aggravated form, whilst the divorce from the clinician is more complete to day than at any other period in the history of medicine. If anatomy is to be taught to medical students on purely academic lines apart from hospitals and the study of disease, in water tight compartments of medical curricula, and with examinations which are mere feats of memory, so long is it certain that as thus taught, crammed, and forgotten, it subserves no useful purpose in the study of disease.

This conception of anatomy as an academic study of the dead has resulted in an over accumulation of largely unimportant detail. The unfortunate student of medicine is unable to differentiate between the vital and the useless. To him articulations of carpal bones are of equal import with lymph glands, probably more, because he can see the former and very seldom sees the latter. Relations of trivial arteries—which the surgeon seizes and ties—are matters to be learnt by rote, and bask, in the student's eyes, as largely as great veins, epiphyses, and lymphatics. Muscles are studied with a meticulous attention to trivial details of osseous attachment, but with no conception of their collective functions in the living subject. Swamped in a morass of detail the student can no longer see the distant tree of knowledge for the mud.

Man is an animal—a highly specialized one in some directions, much less so in others. In his bodily structure and functions he conforms in every detail to the great and

universal laws of nature, and hence the student of anatomy must understand these laws and realize that they are the laws of the living and not of the dead. Anatomy is not, therefore, merely a study of structure. It is rather a study of the modification of structure to function, of impairment of function, and of the different vital conditions under which these functions are carried out. Properly interpreted, such a study leads logically and inevitably to an understanding of the phenomena of life as well as to those of disease. Its teaching necessarily implies a wider vision than is to be obtained from the dissecting-room cadaver, and compels from the expert some general acquaintance with embryology, histology, biology, and anthropology. A knowledge of medicine and surgery goes without saying. In this conception of anatomy there is little room for petty details of structure, but there is an immense field for observation, study, research, and quickened interest.

Of the many thousands of students whom it has been my privilege to teach I have never yet met one who has displayed the smallest interest in the purely anatomical construction of, say, the human shoulder-joint. Show the same man, however, that this generalized structure pervades the whole vertebrate kingdom; that modifications of this structure necessarily occur in different animals according to the specific purposes to which the limb is put; that man is no exception to this law, but that his shoulder-joint is also modified for man's particular purposes, and that this modification necessarily means a liability to frequent dislocation, and that once it occurs muscular action will play an important part in the subsequent events of diagnosis and treatment—then that student's acute interest is not only aroused, but his reasoning powers are stimulated, his memory is quickened, and his observational powers are directed to the fact that he himself possesses a shoulder-joint. He has thus travelled a long way on the path of truth—the path that leads to the living and not the dead.

Take, again, the arch of the aorta, with its long list of anatomical relations. Their acquirement by mnemonics, rather than by reason, is but empiricism. On the other hand, show the student, if possible, a case of aneurysm of the aorta; explain the physical laws which underlie the occurrence of aneurysm of the aorta and of the popliteal artery; demonstrate that all the clinical phenomena of aneurysms are wholly referable to pressure on anatomical structures; elicit from the student which of the aortic relations must be so pressed upon, and why, and what follows, and a totally different and more lasting impression is made upon the mind of the auditor than can possibly be made by a mere recital of names.

The human hand and foot, taught from a basis of evolution, embryology, and morphology, leading on to function, and through function to a loss of function—that is, disease—is an altogether more useful and profitable business than any mere collection of osseous articulations, muscular attachments, and relations of trivial arteries. The central and autonomic nervous systems also furnish—as do, indeed, almost all parts of the human body—many splendid instances of the real conception of anatomy as a study of the living. That anatomy can no longer be regarded as mere details of the dead is amply proved by this last system. Dissections on the cadaver—even the most careful—display but one portion of the autonomic nervous system, namely, the vertebral sympathetic, and not even the whole of that. If this be the limits of the student's horizon it is not humanly possible for him to acquire any adequate knowledge of the structure and functions of the whole of this important system. Doubtless physiology will assist him, but his naked-eye anatomy will not. Similar remarks apply equally well to the central nervous system, to the surgically important epiphyses and lymphatics, and to muscular actions and control. If anatomy is not to lead to a study of life, and through life to disease and its treatment, its failure must be writ large across the page of medical history.

Passing in the next place to points of more technicality but of less importance, human anatomy is suffering rather badly at the moment from its nomenclature. That nomenclature is out of date, and requires urgent and prompt revision. To squabble as to whether we shall employ the Basle anatomical nomenclature or revert to the still more antiquated "old terminology" is to serve the science badly. The latter is hopeless confusion and the former is already out of date. There is no room in the anatomy of

the living for anything but an accurate, scientific, and biological nomenclature which, within limits, shall be equally applicable to embryology and morphology. Such terms as "anterior" and "posterior" should give way to "ventral" and "dorsal," nor is there any scientific justification for the retention of such names as "inferior epigastric artery," as the artery is not "inferior" in any other animal but man. It is also open to question if we are justified, in view of modern neurological knowledge, in speaking of "branches of distribution" of both afferent and efferent peripheral nerves. These criticisms notwithstanding, we owe much to the labours of the Basle International Commission, amongst other things the elimination of nearly 25,000 useless synonyms from the already long list of the names of gross anatomy. That the Commission's work is now out of date is undoubted, and there is urgently wanted a new commission of English-speaking anatomists, physiologists, and clinicians to determine the main principles to be adopted in the nomenclature of known facts, leaving details to a smaller committee of the Commission. As anatomical nomenclature concerns the whole medical profession, it would be well for clinicians to be consulted. Much of the opposition towards the Basle nomenclature has arisen from ignorance of the principles involved, and from the fact that it was largely a purely anatomical commission. With the main principles determined, a smaller and permanent committee of, say, the Royal Society, is required to determine from time to time the terms to be employed for the new facts discovered by research. Recent work on the autonomic nervous system is a conspicuous example of the confusion which is arising from the chaotic and improper use of terms and expressions for which there is no official sanction and but little foundation in fact.

That anatomical textbooks abound in a mass of detail, with little or no reference to function, and much of it of no importance, is easily verified by consulting them. Let one example suffice. The pectoralis minor muscle will be found described with the most faithful attention to the minutest points of its attachments. Why any student should be expected to burden his memory to the exclusion of his reasoning and observational powers with such verbiage—one had almost said garbage—is difficult to understand. From the standpoint of biology they do not elicit the important truth that, in man, the muscle has undergone retrogression from its more functional condition in the bird, which is in accordance with the great evolutionary laws underlying modification of structure to function; whilst from the standpoint of surgery the only important fact about the pectoralis minor muscle consists in its general relation to the ventral axillary wall, and to this, curiously enough, the student's attention is not directed by his textbook. Could not, then, much useless detail be eliminated from our anatomical textbooks, thus making room for facts of greater interest and wider applicability? Personally, I think it not only could but should, though conscience compels me to admit that I have myself been guilty of much which I also condemn. The real truth is that without the active co-operation of the clinician it is impossible for the anatomist to know how far he may proceed with safety in the elimination of the unnecessary. It should, however, even now be the plain duty of the teacher to tell his students where, how, and why much of this detail can be dispensed with.

The limited conception of anatomy as a study of the dead has also tended to limit the field of research, as has also that other conception that anatomy is restricted to the study of Man. Its aim is undoubtedly Man, the living man, but its foundations are to be sought in the study of all vital phenomena. The fields of heredity, morphology, and physical anthropology offer great and unrestricted possibilities to the anatomist of the living. The human cadaver offers few such fields.

This conception of human anatomy as a study of the living and not of the dead—if it be the true one, as experience leads me to believe—necessarily implies some drastic and revolutionary changes in its mode of teaching, in its place in the medical curriculum, and in the position of the laboratories in which its study should be prosecuted. The last mentioned should be as intimately associated with a hospital as is possible. If that be not possible, then much of its higher teaching should be conducted in a hospital with the aid of a projection apparatus, the living subject, and the clinician. Its study should not be restricted to

certain terms of the curriculum, but should be spread over most, if not all, the terms of that curriculum, and should be directly linked up in the form of team work with other subjects such as medicine, surgery, obstetrics, neurology, and the special senses. The actual dissecting can be completed in the earlier years of the curriculum with the elimination of much of the useless detail with which it is now encumbered. The supervision of this earlier part of the work can be safely entrusted to junior surgeons and recent graduates. Its higher and later study should be in the hands of the professional anatomist, who should himself be a member of the staff of the hospital in which his teaching and researches will be conducted. Under such conditions—which are not so Utopian as to be impossible of realization—the subject, the profession, and the patient would benefit enormously.

It may be argued that the extended field of observation which is here urged as being the province of the anatomist is altogether too large. That this is not so is shown by the number of living men who, in both their teachings and their writings, very efficiently cover this wider domain. What is more to the point is where such men are coming from in the near future. The social outlook has been so profoundly modified by the economic consequences of the Peace as to make it certain that no young medical man of promise and ability will nowadays wilfully or deliberately choose the life of denial which, on existing salaries, will be his only reward as an academic teacher of medical science. Neither the universities nor the profession need expect the advancement of medicine by research if the emoluments of such research are to compare none too favourably with the daily wage of the manual labourer. The caustic critic—himself possibly paying supertax—need not regard this as a personal "grouse." It is a very genuine fear for the future of a branch of medical science to which every practitioner owes so much.

To many the ideas herein expressed will doubtless appear heterodox and revolutionary. On the other hand, a recent visit to England has convinced me that there is a much larger number who are very cordially in agreement with the main conception of this paper, which is that anatomy is a study of the living, and that its methods require modification. It is perhaps unnecessary to adduce evidence of the thesis, but it may be well to point out that the pages of *Medical Education in Europe*, published in 1912 by the Carnegie Foundation for the Advancement of Teaching, contain ample evidence of the fact that an anatomical institute should be in close co-operation with a hospital. The recently published report on the medical curriculum by the Edinburgh Pathological Club is similarly convincing as to the impossibility of teaching human anatomy in a water-tight compartment of that curriculum. The discussion at Cambridge in June, 1920, on the preliminary medical sciences—and particularly the eloquent words of Sir George Newman and Professor Arthur Keith—intensifies the necessity for change in the relations of the ancillary sciences to medicine. As Osler remarked, "Biology teaches the problem of life at every point, and may claim, as no other science, completeness of view and a comprehension which pertains to it alone." This is verily the living anatomy herein advocated, as is also Keith's dictum that "Anatomy could be made a living practical part of medicine." Why is it not?

A NOTE ON THE USE OF ANTIGONOCOCCAL SERUM.

By FRANCES IVENS, M.S.LOND.,

HONORARY MEDICAL OFFICER, DISEASES OF WOMEN, STANLEY HOSPITAL, LIVERPOOL.

THE prevalence of gonorrhoea in young and otherwise healthy married women¹ makes it peculiarly necessary not only to improve technique but to utilize all available means to make conservative gynaecological surgery a success in the presence of this infection. Until the last few years antigonococcal serum therapy has not been generally employed, although as early as 1895 de Christmas² experimented with it in guinea-pigs and rabbits. Wassermann and Wertheim confirmed his

experiments, the former showing that the poison was contained in the body of the microbe, which did not belong to a diffusible group. These results were applied by Rogers and Tory³ in 1906, and Parke Davis's antigonococcal serum was used successfully in the treatment of gonorrhoeal rheumatism. Recently Paraf⁴ pointed out the points of resemblance between the meningococcus and the gonococcus, and urged the necessity for methods of local application of the serum to bring it into immediate contact with the microbe, as is done in the treatment of cerebro-spinal meningitis by intrathecal injections. Paraf supported his views by inoculation experiments in the anterior chambers of rabbit's eyes, and by intrathecal injections into monkeys. With Nicolle's serum he cured 14 out of 16 cases of arthritis by the intra-articular injection of serum. This serum is active, possessing agglutinating, bacteriolytic, and bactericidal qualities, and is endowed with therapeutic properties against different strains of gonococci.

Encouraged by the results obtained during the war by the use of specific serums in wound infection, and more especially in gas gangrene,⁵ I determined a year ago to experiment with antigonococcal serum in the treatment of some of the cases of gonococcal infection coming under my care. I employed serum in about 30 cases, in 22 of which tubal infection was the most marked feature. Endocervicitis was present in three, and in three cases of arthritis one had occurred during pregnancy, another in the puerperium.

I adopted three methods of application. In one series I gave the serum subcutaneously diluted in normal saline, usually in a dose of 20 c.cm., repeated at intervals of a couple of days, every three days, or occasionally a week, giving in all from 20 to 200 c.cm.

In another series, on the supposition that the toxin is not diffusible, I tried the intraperitoneal method. Where there were dripping pus tubes or a pyosalpinx the tube was washed out with normal saline, after being, if necessary, opened up. Conservative surgery was adopted when possible, both tubes, or at any rate one, being left. With a syringe 20 c.cm. of serum was injected into the tubes, sometimes into the ovary, and the residue left in the pouch of Douglas. The abdomen was then closed without drainage, and the Fowler position adopted. To avert anaphylactic shock a subcutaneous or rectal saline was given simultaneously. This method, which we employed empirically during the war, has been shown by Richey⁶ to have a scientific basis—namely, that sodium chloride has a protecting action against the assailing infection. Lumière and Chevrotier⁷ have recently shown that other sodium salts act as well.

Thirdly, in a few cases of endocervicitis with profuse leucorrhoea I tried serum packs in the vagina, alternating daily with packs moistened with equal parts of 10 per cent. salt solution and 5 per cent. carbolic acid. In one case 200 c.cm. of serum were used, but my limited supply did not permit me to utilize this method as frequently as I wished. The after-history of these local cases has been peculiarly good—one has recently become pregnant, another, who had had previous ineffective treatment extending over a couple of years, got quite well, all trace of gonococci disappearing.

In no case have I used serum intravenously, as it is the only method in which I have seen fatal anaphylactic shock supervene after the use of serum. With repeated doses there is little doubt that it is safest to use the fractional method, and not to allow more than seven or eight days to intervene between the first and second doses.

With two exceptions all these patients were married women. Thirteen had no children, and nine one only—a striking percentage of sterility. All but three were between 20 and 30 years of age.

Every effort was made to confirm the diagnosis by bacteriological findings. The history and physical signs were generally clear, and I have not included doubtful cases. The existence of purulent vaginitis and of ophthalmia neonatorum in the children was of diagnostic value. Of the 30 cases subcutaneous injections were used in 19, in 6 intratubal and peritoneal, in 3 vaginal packs, and in 2 cases of Bartholinitis, serum dressings.

RESULTS.

All the cases have made a good immediate recovery. In nearly all, either by personal investigation or through

¹ Read at a clinical meeting of the Liverpool Medical Institution, December 16th, 1920.

their medical advisers, I have made myself acquainted with their after-histories, which have been on the whole extremely satisfactory. There have been three definite failures—one an acute case, where an insufficient quantity of serum was perhaps responsible, and two which relapsed after a period of some months' good health, and where there was every possibility of reinfection. Further operation had to be undertaken in all three cases, otherwise the results have been good. In spite of their dislike of subcutaneous injections many of the women have said they were glad to have them, as they felt the benefit. In nearly every case relief of pain was a marked feature. Seen after varying intervals of months the patients described themselves as feeling splendid, being fit for anything, and able to do their own washing—in fact, they form a marked contrast to many other cases of gonorrhoeal infection where no serum had been given at operation, and where the presence of peritoneal adhesions causes so much pain and disability. In one case pregnancy was apparently proceeding normally. Discharges had stopped, and it was difficult to collect enough for bacteriological examinations, all of which were negative.

SPECIAL CASES.

Case 1.

A good result was obtained by the intraperitoneal use of serum in the case of Mrs. B., the mother of two children, one a girl suffering from gonorrhoeal vaginitis, while the baby had ophthalmia neonatorum. There was a left-sided pyosalpinx and an abscess in the pouch of Douglas. One tube and ovary were removed, and 20 c.cm. of serum were left in the pelvis, the abdomen being closed without drainage. There was a very slight febrile reaction the night of operation; temperature 100°, pulse 90. The patient made a good recovery. When seen eight months later she looked fit and well, and declared that she had never been in better health.

Case 2.

Mrs. V. was a case of acute salpingitis, associated with metrorrhagia. The abdomen was opened, sero-pus mopped out of the pelvis, and the tubes washed with saline solution, but not removed. Serum was administered subcutaneously in saline. There was no febrile reaction. The result was excellent, and her doctor reports that her pelvic condition ten months after operation is most satisfactory.

Case 3.

Mrs. P. was a case of arthritis of the wrist occurring about the seventh month of pregnancy (primipara). There was a profuse cervical discharge. The patient was taken into hospital and 20 c.cm. of serum were given every few days subcutaneously in saline until 150 c.cm. had been given. One injection was made into the tissues round the wrist joint and caused a marked local reaction, with redness and swelling of the limb. This passed off, and both discharge and pain ceased. The baby was born in the maternity hospital and was quite healthy. Both mother and baby were seen some months later in the out-patient department in excellent condition; wrist movements were normal and leucorrhoea had ceased. In this case the patient had left her husband.

Case 4.

Another favourable result was in the case of Mrs. J., where there was a history of leucorrhoea extending over two years. After the birth of a child arthritis of the left hip developed and the patient was confined to bed. She was taken into the maternity rest home for treatment, with her baby, aged 9 weeks. No gonococci were present, but her husband was also suffering from joint pains. Two subcutaneous injections of serum were given at an interval of eight days, each producing a very marked febrile reaction the same evening. The breast-fed baby also developed a serum rash. In this case the result was excellent. Pain ceased and the patient was able to leave the home in about three weeks. When seen in the out-patient department three months later she could walk well, had no pain, and was very pleased with herself.

Case 5.

In a chronic case of hydrosalpinx (Mrs. N., married six years, husband a sailor, no children) both tubes were opened up. Three doses of serum were given subcutaneously at intervals of forty-eight hours. There was a marked febrile reaction each evening, the pulse being 116 and temperature 104.6° on one occasion. This patient was seen nine months later—fornices clear, no discharge. She said she was in excellent health.

Case 6.

Another case, Mrs. T., is interesting for the light it throws on obscure causes of puerperal infection. This patient had been under treatment during pregnancy for both gonorrhoea and syphilis in the venereal disease department.

Before admission to the maternity home discharge had ceased for some weeks, and the Wassermann test was negative. The confinement was normal and was conducted under the strictest

aseptic conditions, which include the shaving of the vulva and the wearing of gloves by all associated with the conduct of the labour. On the fifth day a rigor occurred, and the temperature rose to 102.8°, pulse 120. The patient was anaesthetized and thoroughly examined, the uterus being curetted and douché. It seemed so probable that the case was one of latent gonococcal infection lighting up in the puerperium that at the same time I gave 10 c.cm. antigonococcal serum with 10 c.cm. antistreptococcal serum. The latter was given not because the case was believed to be one of streptococcal infection, but as a prophylactic against a secondary infection. Temperature and pulse dropped to normal, and the patient made a good recovery.

The diagnosis was confirmed by the presence of gonococci in the uterine discharge. There were no streptococci.

From such a limited number of cases I do not presume to draw any definite conclusions, but I think these favourable after-histories warrant further experiment and study. I am hoping also to receive some assistance from bacteriological and immunity experts respecting the best method of administration of the serum, with regard to the site of the injections, their incidence, and the amount to be given. On theoretical grounds it is surprising that subcutaneous injections have been so successful, bearing in mind the nature of the microbe. Can one expect to reach an organism secreting an endotoxin by the blood stream, or must some other method be found by which it can be attacked locally?

Also, what is the explanation of the vigorous febrile reaction in chronic cases where subcutaneous injections have been used, while in the acute infections, where the tubes are pouring out pus, there is practically no febrile reaction either with the subcutaneous or intraperitoneal method?

In conclusion, I should like to take this opportunity of thanking Professor Nicolle of the Pasteur Institute for his kindness in placing so much valuable serum at my disposal; to Professor Beattie and his staff for numerous bacteriological examinations; and to Dr. Ruth Nicholson and my house-surgeons and sisters for their assistance with the notes and observations.

REFERENCES.

¹ Ivens: BRITISH MEDICAL JOURNAL, June 19th, 1909. ² De Christmas: *Annales Institut Pasteur*, tome ix, No. 4, 1895. ³ Rogers and Toxy: *Journ. Amer. Med. Assoc.*, 1906, No. 4, p. 265. ⁴ Paraf: *La sérothérapie antigonococcique*, Arnette, Paris, 1919. ⁵ Ivens: BRITISH MEDICAL JOURNAL, October 19th, 1918. ⁶ Richet: *C.R. de l'Académie des Sciences*, July 7th, 1919. ⁷ Lumière et Chevrotier: *La vie médicale*, October 27th, 1920.

ALBUMINURIA IN RELATION TO LIFE ASSURANCE.

BY

F. PARKES WEBER, M.D., F.R.C.P.

In the following remarks I shall deal only with albuminuria in youth and early adult life. From the point of view of prognosis and examinations for life assurance and appointments for clerkships, etc., I prefer to divide the subject under four main headings.

I.—Albuminuria Connected with Definite Nephritis, Chronic Heart Disease, Acute Febrile Diseases, Amyloid Disease, and other Conditions, such as are met with in Hospital Wards and Ordinary Medical Practice.

These cases are well known, and in the present discussion we are not concerned with them, excepting in regard to so-called "residual albuminuria" following an attack of acute nephritis. As long as there is albuminuria of this "residual" kind a life cannot be regarded as up to the normal standard; there may still be a slumbering inflammatory process in the kidneys (one or both). Mere functional recovery in the general condition of a patient, with persistence of albuminuria, does not mean that the life is a first class one any more than does functional recovery in a case of cardiac valvular disease with the persistence of a valvular murmur and cardiac hypertrophy. The extra amount to be placed on the life should depend on a variety of circumstances—for instance, the presence or absence of tube-casts, the amount of the leakage of albumin, the results of various tests as to efficient

* Read at a discussion on the subject at the Assurance Medical Society, January 5th, 1921.

functional activity of the kidneys, the length of time that the albuminuria has lasted, the blood pressure, and the condition of the candidate in other respects.

II.—*Transient Albuminuria Due to Various Causes.*

Under this heading I would include cases of albuminuria due to slight temporary nephritis and renal irritation, cases connected with dietetic errors, food idiosyncrasies, or the action of drugs, and cases of transient albuminuria caused by excessive muscular work. In many cases that I would place under this heading the precise cause of the albuminuria must remain uncertain, but the important point is that the albumin disappears rapidly and completely and that the general health is and remains good. In such cases several examinations are naturally often required before the life can be regarded as a first-class one.

III.—*Postural or Orthostatic Albuminuria.*

Under this heading I group the cases characterized by the occasional, but not invariable, presence of albumin (sometimes little, sometimes much) in the urine passed when the patient is up (that is to say, has been up for some time) but not in that passed when he is in bed or immediately after he has been lying for some time—for instance, in that passed immediately after the night's rest on getting out of bed in the morning. The albuminous urine in these cases frequently contains an excess of "nucleo-albumin" or mucin,* and not rarely calcium oxalate crystals are found on microscopic examination, and sometimes a few red blood corpuscles. "Cylindroids" in fair numbers are frequently observed, but the presence of true tube casts, excepting a few occasional hyaline casts (found with the aid of the centrifugal machine), should be regarded as suggesting some superadded renal irritation or slight actual nephritis.† I believe that the only practical way to distinguish these cases in ordinary practice is to obtain samples of the candidate's urine passed immediately after getting out of bed in the morning. In genuine cases these samples of urine should be found to be quite free from albumin. It is an unfortunate mistake occasionally made to speak of the "morning urine" in cases of orthostatic albuminuria being free from albumin, for it is precisely the urine passed at about 10 o'clock in the morning which may be especially albuminous. For practical purposes I think that what is called "lordotic albuminuria" (L. Jehle and others) should be regarded as a variety of orthostatic albuminuria in which a decidedly lordotic position of the body acts as an essential and determining (though not the only essential) cause of the albuminuria.‡

In the discussion on the after-history of cases of albuminuria occurring in adolescents, which took place on May 2nd, 1911, at the Medical Section of the Royal Society of Medicine, I made some remarks on the favourable prognosis in such cases,§ and said that I did "not think that albuminuria occurring in apparently healthy adolescents could justly be regarded as belonging to any other class than orthostatic albuminuria, unless it could be definitely ascertained that the urine passed immediately on getting out of bed after the night's rest contained albumin." If anything, I am now still more convinced that in uncomplicated cases of orthostatic albuminuria the life may be regarded as a normal one from the life assurance point of view. Moreover, no young person should be prevented from living an ordinary active life merely because of the presence of orthostatic albuminuria. Indeed, for these cases an active life—as much as possible in the open air, without over-fatigue—is probably the best. True orthostatic albuminuria may occasionally be met with up to 25 to 30 years of age (and possibly even later in life). In some way or other it is often connected with the tall

* A trace of nucleo-albumin in the urine passed immediately on getting out of bed in the morning must not be mistaken for albumin.

† The brachial systolic blood pressure in these cases is in general, I think, slightly below rather than above the average.

‡ The voluntary assumption of a lordotic position of the body (artificial lordosis) is sufficient in some subjects to induce temporary albuminuria. This favours the view that in cases of "orthostatic albuminuria" it is not the ordinary muscular exercise of walking about, but really the upright position of the body, which induces the leakage of albumin in the urine when the affected individual gets up after a night's rest.

§ Cf. also F. P. Weber, Remarks on Orthostatic Albuminuria, *British Journal of Children's Diseases*, London, 1911, vol. viii, pp. 385-390. In this paper I referred to individual cases I had met with.

"lanky" build of body suggestive of viscerotaxis; it has been much written about, especially by Continental authors, and, as every doctor now knows, is frequently associated with, and excited by, lordosis (Jehle). There is nothing surprising in the fact that it may occasionally exist in association with true nephritis (for instance, after scarlatina), and that it may be met with in the subjects of tuberculosis, syphilis, etc. The few *post-mortem* examinations that have been recorded tell us nothing more than this. It seems, indeed, quite natural that, occurring, as orthostatic albuminuria not rarely does, in "overgrown" children and in tall, flat-chested and often lordotic adolescents, it should be occasionally associated with early pulmonary tuberculosis. I have observed orthostatic albuminuria in two young men with grave forms of congenital heart disease. Dr. Mackenzie Wallis has kindly informed me that in the albuminuria case to which he referred—a man in whom albuminuria was present for thirteen years without apparently harming him until at last he died at the age of 30 years from uraemia—the albuminuria was not of the orthostatic type, and was almost certainly due to a true chronic nephritis.¶

In regard to prognosis (and life assurance) in cases of adolescent albuminuria help can doubtless be obtained from a chemical examination by estimating the relative proportions of serum-albumin and globulin in the urine, but it is of at least as great importance to ascertain whether the albuminuria conforms to the orthostatic type—whether albumin is altogether absent from the urine passed immediately on getting out of bed in the morning—though this latter investigation may give rise to considerable inconvenience if the examinee cannot be trusted.

IV.—*The Presence of Albumin (frequently only a trace) accompanying Minute Quantities of Pus, Blood, or Semen in the Urine.*

The slight opacity in the urine due to the presence of minute quantities of pus or blood, or pus and blood, in the urine may easily be overlooked, or wrongly neglected as of no importance, in examinations for life assurance or appointments such as clerkships, etc. (Naturally in the case of females a difficulty is more likely to arise owing to admixture of the urine with vaginal or slight leucorrhoeal discharge.) The haze which calls for a microscopic examination may be not more than that due to the presence of bacteria in urine from cases of bacteriuria or in urine which is decomposing. I do not know how it compares with the opalescence which, according to Mackenzie Wallis, may exceptionally be observed in urines containing an excess of euglobulin. Whenver it is evident by the ordinary tests that an opacity (however slight) in the urine is not due to phosphates (or, after cooling, to urates), a

F. P. Weber, Congenital Heart Disease, with Extreme Secondary Polycythaemia and Orthostatic Albuminuria, *Edinburgh Medical Journal*, 1909, New Series, vol. ii, p. 18; F. P. Weber and G. Dörner, Congenital Pulmonary Stenosis, *Proceedings of the Royal Society of Medicine*, Clinical Section, London, 1911, vol. iv, p. 85. In connexion with these two cases I find that F. Eigenberger (*Zentralblatt für innere Medizin*, Leipzig, 1920, vol. xli, p. 354) refers to the case of a young man with polycythaemia rubra (secondary to cardiac disease, if I rightly understand the author) in whom the presence of orthostatic (lordotic) albuminuria was discovered; a lordotic position of his body caused his urine to contain albumin, a little blood, and abundant cylindroids.

¶ Dr. Mackenzie Wallis tells me that though there was well marked globulinuria in this case, the patient was observed to have puffiness about the eyes in the early mornings; his brachial systolic blood pressure was constantly 160 mm. Hg. and red blood cells (though no tube casts) were found in the urinary deposit. The case has been described in full by Dr. Ivor J. Davies, *Lancet*, 1920, ii, p. 1249.

§ Cf. R. L. Mackenzie Wallis, Non-nephritic Albuminuria, *Proceedings of the Royal Society of Medicine*, Section of Medicine, 1920, vol. xiii, pp. 96-104.

¶ Mackenzie Wallis (*loc. cit.* p. 100) writes: "In my opinion euglobulin is really globulin which has associated with it a small quantity of lipoids. In the respect euglobulin is identical with the lecithin-globulin isolated from pseudo-chylous effusions, the degree of opalescence depending on the amount of associated lipoids. This euglobulin is precipitated by acetic acid in the cold, and is, in my opinion, the protein present in the urine which gives this test. An excess of this euglobulin containing excess of lipoids—either in the blood, pleural, pericardial, or peritoneal effusions, or in the urine, gives rise to a marked opalescence, and when this globulin is removed then the opalescence disappears." Mackenzie Wallis quotes a case described by Bramwell and Paton (1892), in which actually the urine spontaneously deposited rhombic crystals of globulin. In regard to pseudo-chylous effusions cf. also Mackenzie Wallis and Schöllberg, *Quarterly Journal of Medicine*, Oxford, 1910, vol. iii, p. 301; Mackenzie Wallis, *Proceedings of the Royal Society of Medicine*, Medical Section, 1913, vol. vi, p. 135; and H. A. Ledard, *ibid.*, p. 123.

microscopical examination (even a hasty one, without waiting for a sediment to form and without the help of the centrifugal machine) may prove of extreme value. At examinations for appointments and life assurance the discovery of minute quantities of blood, not sufficient to produce any reddish coloration of the urine, may lead to the detection of renal tuberculosis, as in the case of a young man whom I recently examined for a clerkship. In such cases the correct diagnosis must of course be confirmed by special examinations, such as by cystoscopy and by catheterizing the ureters, to see if only one kidney is affected. On repeated examinations in cases of this class the urine may sometimes be found apparently free from albumin (by the ordinary boiling and acidifying test), though its slight opacity when freshly passed should lead to a microscopical examination being made. On rare occasions, in such cases, even the slight obvious opacity may temporarily be absent from urine, which by microscopical examination of the centrifuge sediment is found to contain minute quantities of blood or pus.

I understand from Dr. Lister (though I have not observed it myself) that the urine at the commencement of an attack of gonorrhoea (congestive stage) may sometimes contain a little albumin even before the appearance of any purulent discharge.

After the subsidence of an attack of haematuria of uncertain causation the presence of a little pus in the urine by microscopical examination may indicate grave disease, such as a malignant tumour involving the pelvis of one kidney.* This whole subject, however, I need not further discuss here.

ON THE ACTION OF CERTAIN SPECIAL PREPARATIONS ON MALARIAL PARASITES AND THEIR EMPLOYMENT IN THE TREATMENT OF MALARIA.

BY

MAJOR J. PRATT-JOHNSON, M.C.,
(D.A.D.M.S. PATHOLOGY),

MAJOR KENNETH GILCHRIST, M.C.,

AND

CAPTAIN HAY-MICHEL, S.A.M.C.

THESE investigations were carried out at No. 4 General Hospital, S.A.M.C., Roberts Heights, during 1917-19 on malarial patients invalidated from the German East African campaign. The majority of the cases were of a severe type, associated with marked anaemia and debility, numerous relapses occurring in hospital while under quinine treatment (25 to 30 grains daily). Of 8,788 hospital cases 61 per cent. showed benign tertian parasites in their peripheral blood, 23 per cent. malignant subtertian, 16 per cent. both benign tertian and malignant subtertian parasites. The average period in hospital and convalescent camp of these cases was fifty-one days, during which time the blood was examined at weekly intervals and the patients kept on routine daily quinine treatment. Parasitological relapses occurred during this period of observation in 24 per cent. of the benign tertian cases, 11 per cent. of the malignant subtertian cases, and 39 per cent. of the mixed infections. The circumstances under which these cases contracted malaria (a particularly strenuous military campaign in the tropics) suggested a special terminology to meet this resistant clinical condition—namely, "campaign malaria," which apparently owes its intractability to repeated reinfection associated with severe physical strain in unacclimatized individuals only partially protected from a tropical climate and frequently insufficiently supplied with suitable food.

The frequency with which relapses occurred and the slowness with which these patients recovered a condition of good health emphasized the importance of testing any

remedy which might cut short the period of treatment necessary and reduce the number of relapses. Accordingly these investigations were initiated, with the object of providing if possible a more effective treatment. It is not proposed to deal in this paper with the comparative studies made of the results of treatment of different infections with varying doses of quinine administered by the oral, intramuscular, and intravenous routes. The practical outcome of this work, however, was the adoption of a standard treatment for all average cases of malaria. This treatment consisted of 30 grains of quinine in solution by the mouth daily for three weeks, followed by 20 grains daily for one month and subsequently 10 grains daily for two months.

NEO-SALVARSAN, SALVARSAN, NEO-KHARSIVAN, KHARSIVAN, GALYL.

In view of the debilitated condition of many of the cases selected for treatment it was necessary to exercise the greatest care in the employment of these toxic preparations. Accordingly the patients were specially prepared, and the dose of the "606" preparations employed was invariably about half that dose commonly used for the treatment of syphilis (neo-kharsivan, neo-salvarsan, 0.45 gram; salvarsan, kharsivan 0.3 gram; galyll 0.2 gram).

Until some experience of these preparations had been obtained in malarial patients it was customary at first to give intravenous injections at weekly intervals. Subsequently, however, it was found that intravenous injections could with safety be given on alternate days for three or four injections, and in one of the cases reported in this series fourteen intravenous injections of 0.2 gram galyll were administered during an inclusive period of twenty-two days, as many as five injections being given on successive days without any obvious harmful effects.

During the past three years some thousands of intravenous injections of these preparations have been administered in malarial subjects without a single fatality. It is therefore clear that the employment of intravenous injections of the above preparations in malarial subjects is not attended by any appreciable or special risk, provided the doses and methods recommended are used and the precautions enumerated are fully observed.

Apart from the general contraindications in regard to the employment of these preparations commonly recognized when considering the treatment of syphilis, it is necessary specially to consider the following points in regard to the employment of these preparations in malarial subjects.

(a) *Tachycardia and Dilatation.*—These are symptoms of the disease resulting from anaemia and toxæmia. They improved, however, rapidly as a result of intravenous injections of salvarsan and galyll, and in 154 cases subjected to this treatment, the majority of whom had some cardiac embarrassment, not a moment's anxiety on this score was experienced.

(b) *Pyrexia.*—Some observers have held that following an injection of "606" or galyll the temperature often rises 1 to 1.5 degrees, sometimes accompanied with slight rigor, nausea, and vomiting as part of the general reaction to the drug. In a series of over 790 injections these phenomena were observed only seven times with the above doses.

(c) *Renal Complications.*—As these drugs are toxic, it is necessary for the patients' safety that they should be eliminated fairly rapidly. Where, therefore, there is a history of recent nephritis, or where the symptoms of such a condition are present (albumin, oedema, etc.) an injection should not be given.

(d) *Gastro-intestinal Conditions.*—As vomiting is also a fairly frequent symptom of reaction after injection, severe vomiting, diarrhoea, or obstinate constipation should be corrected before an injection is given.

Preparation of the Patient.

Sufferers from malaria should have complete rest in bed for at least twenty-four hours before an injection. Their diet should be light and easily digested during this period. The bowels should be opened either by a purgative pill (for example, pil. hydrarg. coloc. co. with hyosc.) the previous night, followed by saline (mist. alba) the following morning or by an enema in the morning before injection. A light breakfast—one egg, two slices of toast, and one cup of tea—given at least four hours before injection, may be allowed, but no food should be

* In one such case, a man, aged 33 years, under my observation in 1918, the patient (owing to some mistake) was forced to join the army, but was soon transferred to a military hospital and then set free. He died in March, 1920, and the post-mortem examination showed a malignant tumour and pyonephrosis of the left kidney, with secondary tumours elsewhere in the body. This was Case II in a paper which I published (in regard to another subject) in the *International Clinics*, Philadelphia, 1920, series 30, vol. iii, pp. 43-51.

given again till four hours after the injection, when a cup of tea with a slice or two of bread-and-butter may be taken. A complete meal should not be allowed until next day. A sample of urine of the preceding twenty-four hours should be tested on the morning before injection, and if this is found to contain albumin or sugar the injection should not be given.

Considering the small doses that are advocated in these cases the above precautions may seem excessive, but in view of the great debility of these patients and the frequency of dosage advocated, it is important to carry out such preparatory measures if untoward incidents are to be avoided.

Reactions.

Some of the reactions have been alluded to. With such small doses, 0.2 or 0.3 gram, anything approaching a marked reaction has not been seen. A few cases complained of congestive headache. In 650 injections of galy, only on one occasion was an actual rigor observed to follow an injection, and as in this case a tertian paroxysm was expected on this day, it was in all probability quite unconnected with the injection. Vomiting was observed in one case in which 0.5 gram salvarsan had been given.

Results.

The total number of patients treated for purposes of investigation was 154. The clinical action of "606" preparations may be considered under the following headings:

1. *Nervous.*—Headache frequently disappeared not to return even with subsequent rigors.

2. *Pyrexia.*—Where rigor and pyrexia followed an injection at the usual period of the vegetative cycle of the parasite they were invariably milder in degree, and frequently aborted—in fact, experience has shown that these drugs are of considerable diagnostic value in differentiating the two main types, benign and malignant, the former being almost invariably aborted.

3. *Tonic Effect.*—Generally speaking, the tonic effect of "606" preparations is well marked, and rapidly becomes apparent; anorexia, lassitude, and debility soon give way to a feeling of well-being, while tachycardia and shortness of breath, consequent upon anaemia and cardiac dilatation, rapidly improve.

4. *Spleen.*—Splenic enlargements under the influence of these drugs disappear with remarkable rapidity.

5. *Liver.*—In cases where enlargement of the liver was marked with icterus of skin and conjunctivae, rapid improvement has generally followed a single injection, bilious vomiting, furred tongue, and foul breath clearing up within a short period.

6. *Lungs.*—A number of men with malaria were admitted suffering from a dry bronchitis with severe cough. It was noted that rapid improvement followed an injection, though the same frequently occurred after a few doses of quinine had been taken.

Action of "606" Preparations on Malarial Parasites.

1. *Benign Tertian Malaria.*—As a result of numerous observations on the blood after intravenous injections with the above preparations in the doses advocated, without any other medicinal treatment, it was definitely determined that "606" preparations exert a marked parasitocidal action on the benign tertian parasite. Thick blood smears showing numerous parasites commonly become negative within twenty-four to thirty-six hours. No appreciable difference was observed in these different "606" preparations, the result of treatment being closely similar in each case. The action of these preparations is closely analogous to the action of quinine, although "606" preparations appear to be more active and to produce much more rapid effects, especially in chronic resistant infections associated with enlarged spleen and marked anaemia.

2. *Malignant Subtertian Malaria.*—The action of "606" preparations on tropical malaria exhibits a very marked difference from their action on benign tertian malaria. Observations showed that "606" preparations have no definite parasitocidal action on any stage of the malignant subtertian parasite. When employed, however, in association with quinine, these preparations appear to render the parasites more vulnerable to the action of quinine, the

infection being controlled and cured with smaller doses of quinine than would be required without these preparations. The employment of "606" preparations in malignant subtertian malaria appears to be specially indicated in resistant infections with marked anaemia and cachexia, owing to their action in breaking down resistance to quinine and their tonic effects.

Relapses.

The selective action of "606" preparations for benign tertian infections is very marked. In spite of this, relapses are common even when this preparation is combined with quinine treatment. Total eradication is doubtless possible with "606" preparations alone in early simple infections, but the majority of the cases treated were chronic cases resistant to treatment, of which a considerable number relapsed even while under treatment in hospital. Relapses, however, are much less frequent when several injections are given on alternate days in addition to quinine treatment.

It is not possible with "606" preparations alone to effect Ehrlich's *therapia magna stribi us* except in the earliest infections. Freedom from relapses and total eradication of the infection cannot therefore be promised after treatment with numerous intravenous injections of "606" preparations.

In malignant subtertian malaria quinine must be employed in addition, as "606" preparations have little direct destructive action on the parasites. When these preparations are used in addition to quinine the action of the latter is intensified, and the progress towards recovery is much more rapid.

Detection of Parasites.

The thick smear was always employed in searching for parasites in the peripheral blood; it is a rapid and efficient method of controlling the results of treatment. It is possible to demonstrate parasites easily by this method when it may be impossible to find them on examination of thin films even after a prolonged search. Using this method it was found that in 4,043 cases of malaria admitted into hospital with positive thick smears, 23 per cent. showed parasites persisting in the blood on the eighth day of treatment with an average daily dose of quinine of 23 grains. The average persistence of parasites in thick smears in these cases was nineteen days. This fact indicates the severe nature of the cases and demonstrates the slow action of quinine in reducing heavy infections in markedly debilitated individuals. Resistant benign tertian infections responded readily to "606" given intravenously together with quinine by the mouth owing to the parasitocidal action of "606" on the benign tertian parasites. Intramuscular injections of soamin and quinine orally offered no advantage over quinine and inorganic arsenic in these resistant cases, as the following statistics indicate:

Results of re examination of blood, after an average interval of eight days, in cases of benign tertian malaria, positive on first examination—34 cases treated with quinine and an average of one injection of "606"—compared with 5,171 cases treated with quinine only, and 44 cases treated with quinine and an average of two injections of soamin. In the 44 cases treated with quinine and soamin the blood was re-examined after an average interval of 6.5 days.

	Quinine +606.	Quinine.	Quinine and Soamin.
Number of cases positive on first blood examination	34	5,171	44
Number positive on re-examination	Nil	710	19
Percentage of cases positive on re-examination	Nil	22	22.7
Average daily quinine (grains) in interval before re-examination	11.5	25.2	25.6
Average persistence of asexual forms in cases positive on re-examination	Nil	19	19.2

Mixed Infections.

The failure of treatment with "606" preparations alone to prevent relapses in mixed infections, even when the treatment is pushed, is shown by the following cases:

Case 1.—Mixed infection (benign tertian and malignant tertian). Intravenous injections of 0.20 gram galy on the 1st, 2nd, 3rd, 4th, 6th, 7th, and 8th days. Parasite relapse of

malignant rings on the 16th day, and benign tertian parasites together with malignant rings on the 24th day. A few crescents were also found on the 21st day. No other treatment given.

Case 2.—Mixed infection (benign tertian and malignant tertian). Intravenous injection of galyl 0.30 gram on the 1st day. Parasite relapse of benign tertian on the 12th day. Further injections of galyl 0.20 gram on the 17th, 19th, 21st, 23rd, 25th, 29th, 31st, and 33rd days. Parasite relapse on the 39th day of benign tertian parasites. Crescents were daily found in the blood from the 21st to the 39th day. No treatment other than galyl given during the period of observation.

Case 3.—Mixed infection (benign tertian and malignant tertian). Intravenous injections of galyl 0.20 gram on the 1st, 2nd, 3rd, 5th, 6th, 7th, 9th, 14th, 16th, and 9th days. Parasite relapse on the 20th day, benign tertian parasites and numerous malignant rings. Crescents found daily from the 5th to the 15th days, and not found from the 16th to the 23rd days. Treatment, galyl only.

Case 4.—Mixed infection. Intravenous injections of galyl 0.20 gram on the 1st, 2nd, 3rd, 4th, 6th, 7th, 8th, 14th, 15th, 16th, 17th, 18th, 20th, and 22nd days. Parasite relapse with numerous malignant rings on the 14th day to the 23rd day. On the 24th day benign tertian parasites were also found. Crescents were found almost daily. Treatment, galyl only.

SOAMIN.

Numerous intramuscular injections of soamin were administered in severe resistant cases of various types of malaria. Soamin exhibits no parasitocidal action on the parasites of either benign tertian or malignant subtertian malaria. Its beneficial action is confined to the breaking down of the resistance of parasites to quinine.

TARTAR EMETIC IN "CRESCENT INFECTIONS."

A small series of twenty-seven cases of malignant subtertian malaria with crescents in finger blood were treated by tartar emetic injections, the total number of injections administered being 137.

No demonstrable effect attributable to the injections was observed on crescents. Even repeated doses of 20 cg. of tartar emetic did not appear to produce breaking down of the crescents in the blood.

No advantage as to the rapidity of elimination of crescents from the blood could be demonstrated between a group of cases treated by quinine only and a group of cases treated by quinine together with an average of five injections of tartar emetic. The most rapid and certain method of eradicating crescents from the finger blood is to treat the patient thoroughly with quinine (30 grains daily). Under such treatment crescents disappear in an average of fifteen days. Supplementary treatment with arsenic and iron is indicated, and in unusually resistant cases intravenous injections with "606" preparations, or intramuscular injections of soamin, are advisable to break down the resistance to the action of quinine, of the "ring" forms from which the crescents arise.

In regard to the prevention of relapses, these have occurred in both benign tertian, malignant subtertian, and mixed infections after treatment with an average of four to six injections of tartar emetic in each infection. Tartar emetic has no demonstrable effect on the asexual forms of the parasites of either benign tertian or malignant subtertian infections, and exerts no influence on the clinical course of the disease.

MERCURY AND ANTIMONY OINTMENT.

A small series of eleven cases were treated with quinine and inunctions with an ointment composed of antimony 2 parts, mercury 30 parts, lanoline 68 parts. About 1 drachm was rubbed in daily for fifteen minutes. Inunctions were continued for an average of twenty-five days. The inunctions did not appear to have any direct action on the parasites or to intensify the action of the quinine which was administered at the same time. No therapeutic effects were observed.

CONCLUSIONS.

1. Neo-salvarsan, salvarsan, neo-kharsivan, kharsivan, galyl, administered intravenously, may be employed with safety in the treatment of all forms of malaria, provided the doses and methods recommended herein and the precautions enumerated are fully observed.

2. These preparations, in the doses recommended, exert a marked parasitocidal action on the benign tertian

parasite, thick blood smears showing numerous parasites usually becoming negative within twenty-four to thirty-six hours.

3. These preparations have no definite parasitocidal action on any stage of the malignant subtertian parasite. When used in addition to quinine, the action of the latter is intensified and the progress towards recovery is much more rapid.

4. Generally speaking, the tonic effect of these preparations is well marked in all cases of malaria; anorexia, lassitude, and debility soon give way to a feeling of well-being, while tachycardia and shortness of breath, consequent upon anaemia and cardiac dilatation, rapidly improve. Splenic enlargements disappear with remarkable rapidity.

5. The employment of these preparations is recommended, in addition to quinine treatment, in chronic resistant infections and malarial cachexia. Three or four injections at weekly intervals are recommended. Freedom from relapses cannot be promised even after numerous intravenous injections. In regard to the preparation of the solutions and technique of administration, the usual methods are followed in each case.

6. Soamin exhibits no parasitocidal action on the parasites of either benign tertian or malignant subtertian malaria. Its beneficial action is confined to the breaking down of the resistance of chronic infections to quinine.

7. Tartar emetic has no demonstrable effect on the sexual or asexual forms of the parasites of either benign tertian or malignant subtertian malaria, and exerts no influence on the clinical course of the disease. The most rapid and certain method of eradicating crescents from the finger blood is adequate quinine treatment (30 grains daily) and arsenic.

8. Inunctions of mercury and antimony ointment do not appear to exert any therapeutic action in malaria.

This paper is included in a report on "Malarial Research in South Africa during the War," to the Minister of Defence, Union of South Africa.

Acknowledgements are due to Colonel P. G. Stock, C.B., C.B.E., S.A.M.C., Director of Medical Services, for permission to publish this paper; Colonel G. H. Knapp, D.S.O., Deputy Director of Medical Services; and Lieut.-Colonel Vaughan Williams, D.S.O., of No. 4 General Hospital, and Major J. C. Venmiker, S.A.M.C., without whose hearty co-operation and support it would not have been possible to carry out this work during a period of considerable pressure on the military hospitals.

Memoranda:

MEDICAL, SURGICAL, OBSTETRICAL.

SPASMODIC HICCOUGH.

In view of the recently reported plague of hiccough in Montreal and Paris an account of two cases which have recently come under my care, and are, so far as I am aware, the first cases to be noted in England, may be of interest to your readers.

Case 1.—A man residing near high downland, accustomed to easy open-air life, who had not recently been away from the district, presented as the initial symptoms frontal headache and slight rise of temperature. On the second day a cough developed, and the hiccough first began at the end of a fit of coughing and lasted an hour. In an hour's time another attack occurred, lasting an hour and a half. These recurrent attacks continued for two days. On several occasions the hiccough continued until retching was set up, and, although no material was vomited, the act of retching appeared to stop the hiccough for a time. It was noted that the hiccough was more violently spasmodic than is usual in an ordinary mild persistent attack. The temperature throughout remained at 101° F., and finally dropped by crisis. The frontal headache continued and heavy night sweats occurred. After trying all the usual homely remedies my advice was sought at the end of the first day, and a mixture containing potassium citrate, bismuth subnitrate, tincture of belladonna, and dilute hydrocyanic acid was given every four hours. Very little relief was obtained, and the attack finally yielded at the close of the second day to a mixture of sodium, potassium and ammonium bromide, leaving the patient weak and shaken.

Case 2.—A young man employed in business near the docks. The symptoms differed from those in the previous case in that a smart attack of diarrhoea occurred coincidentally with the onset

of the hiccough. Frontal headache and temperature as in Case 1. No night sweats. The attack did not yield to bromides, and only subsided when benzyl benzoate was given; duration thirty-six hours.

Clifton, Bristol.

URQUHART BARTHOLOMEW, M.R.C.S.

FATAL POISONING FROM INHALATION OF ACID FUMES IN A LABORATORY.

AN engineering student was engaged on December 8th, 1920, in dissolving various metallic substances in mineral acids. The exercises for the day consisted in the identification of pyrolusite (MnO_2), stibnite (Sb_2S_3), and bauseite ($Al_2O_3 + Fe_2O_3$). The mineral acid which was advised for employment was hydrochloric acid, but according to the patient's own statement he made use instead of sulphuric acid.

He placed a vessel containing this acid and one of the metals in an ordinary fume chamber, and on going to remove it about an hour later he inadvertently bent too much into the chamber and inhaled the fumes. He felt, for the moment, sick and dizzy, but experienced no further ill effects till the middle of the following night, when he began to suffer from severe and rapidly increasing dyspnoea. Next day, December 9th, he was seen by Sir Robert Woods, who found him suffering from very severe oedema of the larynx and pharyngeal tissues. Scarification and other treatment was adopted, with the result that the oedema rapidly subsided, but as his general symptoms pointed to severe illness, he came under my care on December 12th.

On this date he looked anxious and ill, there was a slight icteric tinge in the sclerotics, the tongue was furred, the throat still showed traces of the recent severe inflammation, the heart sounds were normal but weak, the pulse was feeble (120 to the minute), and the respirations were rapid. Mild diffuse bronchitis existed, with crepitus, and a pleural rub at the base of the left lung; the abdomen appeared normal. The urine was scanty, highly albuminous, with a faint biliary reaction. The temperature on this date was 103 F. Treatment by alkalis, glucose, oxygen inhalations, etc., was ordered, and the next morning the patient was somewhat better, and was bringing up freely a lemon-yellow coloured expectoration. The improvement persisted for a couple of days, but was then followed by rapidly increasing weakness and loss of weight, and finally a lethal termination on December 19th, just ten days after the initial misadventure. During the last few days the liver became much enlarged, there was persistent diarrhoea of a thin, watery character, fall of temperature to subnormal, extreme and rapid emaciation, cyanosis and rapid breathing, without increase of pulmonary signs.

The inability to state exactly what fumes were the cause of the trouble diminishes the value of this report, but it is nevertheless placed on record owing to its obvious importance to laboratory workers. The professor in charge of the laboratory informs me that the same routine of work has been carried out by classes for years, and that he has never before heard of even trifling malaise. The delay in the development of the symptoms is also worthy of note.

Dublin.

T. GILLMAN MOORHEAD, M.D.

PATENT DUCTUS ARTERIOSUS.

IN your issue of December 25th, 1920, I have read the very interesting account by Dr. Carey Coombs of his four cases of patent ductus arteriosus. In the *Archives of the Middlesex Hospital*, vol. xxxi, No. 13, December, 1913, I reported three cases, all proved by autopsy, of patent ductus arteriosus, with no other lesion present, but all in children under one month old. In all these cases no murmur of any description was heard, and the attacks of cyanosis—varying in length, but completely passing off for longish intervals—were the marked feature of these cases. Whilst serving in the army in Malta I was asked by Sir Archibald Garrod to see a baby with a view to performing tracheotomy, but it was finally decided against, and at the autopsy a patent ductus arteriosus was found. No bruit was present in this case, but cyanosis and dyspnoea were the marked features.

Evidently, from Dr. Coombs's observations, a bruit develops if the individual lives to adult age, and endocarditis is added to the already patent ductus arteriosus. Without the endocarditis I feel sure no bruits of any character are present.

Eastbourne.

E. WILSON HALL, F.R.C.S. Edin.

Reports of Societies.

ALBUMINURIA IN RELATION TO LIFE ASSURANCE.

At the meeting of the Assurance Medical Society on January 6th a discussion on "Albuminuria in relation to life assurance, especially in adolescents," which had been adjourned from the meeting of November 3rd, 1920, was resumed by Dr. F. PARKES WEBER, whose paper appears on page 78. The President of the Society (Dr. T. D. LISTER) was in the chair.

Sir JAMES GALLOWAY related his experience with some cases of orthostatic or, as it might perhaps be called, harmless albuminuria. In the early days of the war, when much difficulty arose from what was called "trench nephritis," he had a conversation at the front with Sir Wilnot Herringham. The scare about trench nephritis had caused a great many examinations to be made, and a certain number of men were found to have albuminuria, which was not surprising in view of the campaigning conditions. But experience showed that a large number of cases with albuminuria which it had been supposed might lead to troublesome results were of this harmless type, and a more extended investigation later on, when the casualty clearing system had further developed, made it possible to define such cases. After a short rest and a period during which they were under careful scrutiny some of these men were passed again for service, and were kept right, at all events for the period of the war. He would not say that even in these cases there was no subsequent trouble, for he did not quite agree with Dr. Parkes Weber as to the total harmlessness of the condition. But the number of men suffering from this orthostatic albuminuria was very much larger than might have been concluded from the experience of civil practice. Great care was necessary in arriving at a diagnosis in such cases. If the question of syphilitic infection were raised, as occasionally happened in such cases, grotesque errors in diagnosis might be made, leading to the use of drugs such as salvarsan in the excitement of the occasion—not a very prudent plan of treatment. The speaker had thoroughly tested such cases, examining the urine before and after exertion. One form of exertion was to walk round the Outer Circle of Regent's Park in a given time, and it was found that after this exercise the albumin was increased in quantity, although on rising in the morning it had been absent or negligible. Another case which came under his care was that of a pensioned soldier who had been discharged on account of nephritis. Albuminuria had been found early in his war service, and he had been sent home, and after a rest sent out again, but finally discharged. This man, who was of the lanky, flat-chested type, was evidently one of the orthostatic cases, and was now practically albumin-free. But the previous diagnosis and treatment had had the effect of giving him a nervous disinclination for much work. Nevertheless, a man of this type, quite apart from his physique or his neurasthenia, was not to be regarded as a first class life, because the functions of the kidney could not be considered as properly performed.

Dr. H. BATTY SHAW said that it seemed to him they could not avoid accepting the position that pre-renal albuminurias or proteinurias were due to nephrotoxic substances brought to the kidney by the blood stream, and not generated in the kidney *ab initio*. If this was so obvious an explanation of cases of proteinuria accompanied by coarse changes in the kidney, was it not probable that the intermittent temporary or occasional proteinuria of adolescents, or of persons of any age, was also due to the operation, in a large majority of cases, of foci of infection at a pre-renal site? These, while incapable of producing fever with its associated manifestations, were capable on occasion of producing temporary disorder of function in the renal parenchyma with consequent albuminuria. That orthostatic proteinuria existed had been accepted too readily as proof that the proteinuria, at any rate of adolescents, was mechanical in its origin. Foci of inflammation at any pre-renal site were quite capable of causing proteinuria, whether temporary or for all time, slight or severe, and it was safe to assume that the foci of infection which only produced proteinuria in young

persons on assuming the erect posture need be no bar to insurance. Dr. Shaw detailed a series of observations which went to show that proteinuria might be constantly present although the percentage of damaged glomeruli of the kidney was very low, and might be only occasionally present in other cases in which the percentage of damaged glomeruli was large; his conclusion was that the degree of proteinuria was not proportional to the number of damaged glomeruli, and must be assumed to depend rather upon some agency present in the blood which was capable of altering the glomerular elements sufficiently to allow proteinuria to occur, without, however, altering them structurally. Dr. Batty Shaw's practical suggestions were as follows:

Cases of adolescent proteinuria—that is, in persons under 30—showing no other abnormality than proteinuria, which was absent when the urine was examined after a night's rest, should be accepted at ordinary rates. If the proposer showed proteinuria after a night's rest, his insurance should be postponed, or he should be given a short endowment with a load.

If the adolescent proposer showed proteinuria and hyperpiesis after a night's rest he should be rejected.

If a proposer over 30 years of age showed nothing else but proteinuria, which disappeared after a night's rest, he should be accepted, but with a load; if the proteinuria persisted after a night's rest he should be postponed; and if proteinuria persisted and was accompanied by hyperpiesis, and the latter was not abolished by a night's rest, he should be rejected.

Dr. H. W. COLLIER mentioned the case of a man 56 years of age, who had lived an exceedingly active life, and was of good family and personal history, who proposed himself for assurance. Thirty years previously he was declined on account of albuminuria, but two years afterwards was accepted by another company at ordinary rates, the medical examiner, apparently, finding no albumin. The man himself knew, however, that throughout his life, whenever his urine had been tested, albumin had been found save on that one occasion. The speaker recommended his acceptance, but with the addition of five years to the age, and this the man declined, as he considered himself in every way a first-class life.

Dr. H. M. ABEL thought the calcium lactate method of testing likely to be of much use, but it was a treatment, and would usually involve giving doses—and not small doses either—to another doctor's patient. Would it not be good for the office, the proposer, and the doctors, if an arrangement could be made whereby, in special cases only, the examiner could get into touch with the doctor in charge of the case? On the general question, he was of opinion that any given case which was proved to be adolescent postural simple albuminuria, with all other conditions favourable, should be accepted at ordinary rates.

Dr. F. G. CHANDLER mentioned that one of the largest organizations in this country, employing great numbers of boys, who were retained in its service for the rest of their lives, subjected the boys to careful medical examination, and kept a complete record of their sick leaves. Not a few of the boys had albuminuria; at one time such boys were rejected, but for twenty-five years now they had been accepted, and the record of health of these boys was in every respect as good as that of the others. The albuminuria in some cases had persisted up to manhood. It was proved, therefore, that there existed an albuminuria which was not pathological. The speaker maintained that—provided there was no abnormality in the appearance of the person, his past history, and the state of the cardio-vascular system, also in certain urine tests such as for casts and the type of protein—they were justified in passing the proposer as a first-class life even though he had a trace of albumin.

Dr. WITHERS GREEN protested against the use of the terms "orthostatic" and "adolescent," and suggested in their place "functional," "physiological," and "perambulatory." The word "orthostatic" was meaningless now, and would be a difficulty for those who came after.

Dr. HINGSTON FOX, who had opened the subject at the first meeting, said that one thing which had been gained by the discussion was the fuller recognition of the fact that a favourable and harmless type of albuminuria really existed independently of disease of the kidney. He was sorry Sir James Galloway should have repeated the old heresy that in such cases the kidneys could not be quite sound. He did not exclude the phenomenon of septic absorption, as suggested by Dr. Batty Shaw, but in many

of the cases he had seen, when the persons concerned were in robust health with good digestions and capable of much exertion, it was difficult to believe that the passage of a little albumin was due to any septic absorption; it was much more probably due to certain functional states of the blood circulation. He saw nothing better in the way of a name than the "albuminuria of adolescence." It implied no theory and begged no question as to physiological or functional disturbance. What were the causes which interfered with the normal defensive action of the kidney cells in keeping albumin out of the urine? It seemed to him very reasonable that the conditions of blood pressure and of the blood itself in respect to its coagulating power and thinness would be likely to interfere with that defensive property; and Sir Douglas Powell's reminder at the last meeting that the very structure and purpose of the glomeruli was to produce a retardation of current for the functional purposes of the kidney was rather illuminating from that point of view, because if that blood secretion were too much retarded, surely the cells could no longer work as they ought to do.

A CASE OF PLAGUE IN DUBLIN.

At a meeting of the Medical Section of the Royal Academy of Medicine in Ireland, held on December 10th, 1920, Dr. H. DRURY and Sir ARTHUR BALL reported a case of bubonic plague which had occurred in Dublin.

The woman, aged 25, was seen by Sir Arthur Ball, who found a gland in the groin the size of a walnut, with a history of intense local pain of three days' duration. On admission her temperature was 104°. The skin over the gland was not inflamed. The patient was covered with flea-bites. The excised gland was examined by Dr. Synge, who found that it contained large numbers of plague bacilli.

When Dr. Drury first saw the case, on the third morning after operation, he was struck with her typhus-like aspect. The patient's temperature was then 102°, her pulse-rate 100 but very weak, her respirations 22. Except for a deep and exquisitely tender swelling, 2½ in. by 1 in. immediately above and parallel to Poupart's ligament, the abdomen was normal. There was no vesicle or pustule to indicate the site of inoculation. On the sixth day of the disease the temperature began to fall steadily, rising again on the eleventh day to 102°, and becoming definitely normal on the thirteenth day. The swelling above Poupart's ligament gradually subsided.

Dr. BIGGER, in describing the precautions taken by the authorities to prevent extension of the disease, said that as no case had occurred in Dublin for 200 years, an entirely new problem was presented. Some connexion with the shipping of the port might have been expected, but this patient had none, except that she lived near the docks. She had, however, a pet cat which slept in her bed, and which was in the habit of disappearing at intervals. This animal might have been infected by rat fleas, but it was not possible to ascertain the fact owing to its prompt destruction by the sanitary authorities. No unusual mortality had been noticed among the rats at the docks, and the specimens examined were negative as regards plague. The usual measures of disinfection were adopted, and the health authorities in England and Scotland were notified. As no further case had been reported after the lapse of nearly two months, this would probably prove an isolated case.

Dr. W. F. LAW had never seen a case of plague in his colony (British Guiana), but it had occurred in Trinidad on two occasions to his own knowledge. He was surprised to hear that direct infection played such a prominent part; he thought the rat flea was generally accepted as the infecting agent.

Sir J. W. MOORE thought the introduction of plague into this country quite a possible event. A relative in the Royal Navy had told him on his return home after visiting Algiers and Lisbon that plague existed in Algiers and in Lisbon, both places in fairly close communication with the British Isles.

Dr. SPEARES instanced an outbreak in a family in Malta, two members of which died before the diagnosis was made. The laboratory attendant punctured his finger during an autopsy on one of the cases, developed plague, and died.

Dr. SYNGE described the gland removed by Sir Arthur Ball:

It was about 1½ in. in length. It was oedematous and haemorrhagic. Smears from the gland showed very large numbers of Gram-negative bacilli. These bacilli were short and thick, and

stained darkly at both poles, the centre of the bacillus remaining unstained. Cultures on blood agar after thirty-six hours showed small whitish-grey colonies. These consisted of bacilli similar to those found in the direct smears of the gland. Cultures on salt agar after three days showed marked involution forms. A guinea-pig injected with material from the gland died after seven days. It showed general oedema with areas of congestion. The glands in the groin were much enlarged, oedematous, and haemorrhagic. The spleen was greatly enlarged and studded with large numbers of white spots. Smears of the glands and spleen, and cultures from the glands, spleen, and heart's blood all showed bacilli similar to those found in the patient's gland. A culture from the patient's blood on the seventh day of her illness was positive, but bacilli were not seen in a direct examination of blood films.

The morphological and cultural appearances and the result of animal inoculation proved that the bacillus found in the patient's gland was *B. pestis* and that the patient was suffering from bubonic plague.

Dr. DRURY, in reply, said that the entire credit of the case was due to Sir A. Ball, who recognized the inflamed gland as something unusual, and to Dr. Synge, who had the courage to make what appeared at first a very improbable diagnosis. He did not suggest that direct infection in plague was a common route, but it had been shown to occur. He thought antiplague serum more useful in prophylaxis than in treatment.

“VICARIOUS MENSTRUATION.”

A MEETING of the Obstetrical Section of the Royal Academy of Medicine in Ireland was held on December 10th, 1920, with the President, Dr. E. HASTINGS TWEEDY, in the chair.

Dr. BETHEL SOLOMONS read a paper on herpes as a type of vicarious menstruation. He reported a case which had been referred to him by Dr. Wallace Beatty.

The patient was a girl aged 27, who complained of getting a sore on the left cheek every month, which Dr. Beatty described as catarrhal herpes. Bimanual examination under anaesthesia revealed absence of the essential genitalia. It was thought well to confirm this diagnosis, and the abdomen was opened. It was then seen that a candle-like structure passed from one internal abdominal ring to the other, and that the uterus, tubes, and ovaries were absent. On a further search, an ovary of normal size was found attached to a very thin fold of peritoneum, which was in such a position that it might have been intended to represent the broad ligament, and the ovary was anterior to this. There was no ovarian or ovario-pelvic ligament, and the ovary was obviously obtaining its blood supply from the peritoneum in which it was nestling.

Dr. Solomonos, having discussed the question, considered that the case might be ranked as one of vicarious menstruation.

Dr. SPENCER SHEILL agreed with many present-day authorities that vicarious menstruation did not exist. In cases of pink discharge coming monthly from axillae neither red cells nor haematin were found in it. He looked upon herpes as a very common accompaniment of menstruation, as were headaches, swellings, etc. These symptoms increased in menstrual derangements, and were merely manifestations of vasomotor disturbance due to internal ovarian secretion. Where periodical haemorrhages occurred—for example, epistaxis—local causes had invariably been found which, when treated, removed the so-called vicarious menstruation.

Mr. A. K. HENRY said that menstruation involved notable vasomotor changes, and these were controlled by the autonomic nervous system, a system which, taken as a whole, was concerned with widespread reactions. Dermographism, for example, was described as being specially pronounced in certain individuals during menstruation, and it was possible to account for this, and for catamenial herpetic eruptions, by a diffusion of exaggerated vasodilator response, or, as in Dr. Solomonos's case, by a complete directing of vasomotor effects into extragenital channels. In dermatographism urticaria was simulated, while in herpes the results of vasomotor activity proceeded to the formation of vesicles.

Dr. SOLOMONS, in reply, said he was one of those who believed that vicarious menstruation did exist. It was open to question whether his case was actually an example of the condition. According to Dorland's definition, it certainly was. All drug treatments had been tried, and still the herpes recurred every month. He did not remove the ovary, as he thought the absence of its secretion would be more harmful to the girl than the presence of the herpes.

Rebichus.

SCURVY.

IN *Scurvy, Past and Present*,¹ Professor A. F. HESS has provided a very complete and well written monograph on this most important subject. At the present time a large amount of literature is rapidly accumulating, greatly stimulated by conditions produced during the war; much of this literature, though valuable in quality, is difficult of access, and this the author has gathered together and placed before the reader in a manner most helpful and interesting. The book is divided into eleven chapters, dealing with history, etiology, the antiscorbutic vitamine, pathology, experimental scurvy, antiscorbutic foods, symptomatology and diagnosis, prognosis, treatment, metabolism, and relation to other diseases. It contains a number of illustrations, diagrams, radiograms, and a good bibliography; it is practically free from errors or omissions.

The very great experience of the author, both in animal experimental work and in clinical observation on infantile scurvy, renders his deductions of the greatest value. At the outset he makes it clear that there is no etiological difference between adult and infantile scurvy, and that the prevalence of the latter is far greater than is generally recognized, owing to the increased use of artificial foods, which are practically all deficient in antiscorbutic vitamine. He believes that infants brought up on natural milk do not contract scurvy, and he places a rather higher value on unheated cow's milk than is assigned to it by the workers at the Lister Institute. While recognizing that pasteurized and boiled milk are very inefficient, he holds that the value of milk is not appreciably diminished by the rapid drying method used in the Just-Hatmaker process; if so, it is a very valuable and practical substitute for raw milk. He states that there is no basis for assuming an inter-relationship between infantile scurvy and rickets; scurvy, he says, will develop as rapidly when rickets is absent as when present; in practice, however, the two diseases often are present together. For prophylaxis and cure the author would place the greatest reliance on raw orange and lemon juice or strained canned tomato, but he recognizes that germinating pulses and the juice of swedes are of very high value; for infants of one month old he recommends the addition of one teaspoonful of orange juice daily, believing that it is not wise to wait, as is the common practice, until the fifth or sixth month.

There is so much in each chapter of intense interest which might call for comment that it is impossible to do full justice in a review, but we will draw attention to only one more observation—namely, the necessity of early diagnosis in the pre-scorbutic stage, which is far too often unrecognized; frequently, in fact, the diagnosis made is “rheumatic.” The experience of Comby with infantile scurvy emphasizes this graphically; of 55 cases, the diagnosis was erroneous in 45, the infants being treated with sodium salicylate when they were in reality suffering from infantile scurvy.

With regard to foods, the important factors are not only the initial vitamine content of the substance, but the methods of preparation, amount of heat used, the time of storing before use, and the amount taken; for instance, though potatoes contain only small quantities of active antiscorbutic substance, yet they are so widely and largely used that they must be classed as most powerful antiscorbutics. This book comes at a very opportune moment, and should be carefully read and acted on, especially by those interested in child welfare at the present time; the author is to be congratulated on the justice he has shown to every known author in no mean accomplishment.

P. W. B.S.

ORTHOPAEDIC AND RECONSTRUCTIVE SURGERY.

Dr. ALBEE'S work on *Orthopaedic and Reconstruction Surgery*² is one of extraordinary interest to the ortho-

¹ *Scurvy, Past and Present*. By Alfred F. Hess, M.D., Clinical Professor of Pediatrics, University and Bellevue Hospital Medical College, New York City. Philadelphia and London: J. B. Lippincott Co., 1920. (Demy 8vo, pp. 255; 25 figures. 18s. net.)

² *Orthopaedic and Reconstruction Surgery, Industrial and Civilian*. By Fred. H. Albee, A.B., M.D., D.Sc., F.A.C.S. Philadelphia and London: W. B. Saunders Co., 1919. (Demy 8vo, pp. 1135; 891 figures. 6 plates. 50s. net.)

paedic specialist and to the operating surgeon. But it is so personal and the lines of treatment advocated are so often contrary to the accepted teaching that it can scarcely be recommended to the student. It deserves to be widely read, and will, no doubt, be widely criticized, for it extends the author's well-known methods of utilizing mechanical assistance in operating so as to make them applicable to the whole realm of orthopaedic surgery. Dr. Albee is a mechanic of first-class ability; his mechanical genius and his manual dexterity have led him to suggest ingenious operations for many conditions which most orthopaedic surgeons will prefer to treat by other and simpler means. But, after all, this is a common failing with pioneers, and the great advances in surgical technique which the author has initiated can be trusted to find their proper place as they are adopted and tested by other surgeons and subjected to external criticism. Each section contains a condensed but adequate account of the etiology, symptoms, pathology, and diagnosis of the condition under discussion, followed by a good account of the principles of treatment and of the methods generally used. The particular methods of the author are described in great detail, and it is here that the book is most open to criticism. Seldom is some clever method of operative treatment wanting; for example, Albee's method of fixing the spine by a bone graft is already well known and tested, but here are methods of fixation by a bone graft in tuberculous disease of the hip, knee, ankle, tarsus, carpus and shoulder. Paralytic scoliosis, congenital dislocation of the hip, congenital talipes, fracture of the patella, and slipping patella are only a few of the other conditions amenable to treatment by the bone graft. The reader must understand that these methods are new, and that he must regard them in a critical spirit and with an open mind, refusing, perhaps, to accept them as of proved efficacy, but pitting them against other accepted methods of treatment. These new methods must thus act as a stimulus to progress in reconstructive surgery. The descriptions throughout are good and the illustrations copious and excellent. There need be no failure to understand the author's methods. Good bibliographies are added in each section, and these and the text show that the literature has been carefully studied and digested. This is particularly true of the accounts of the more rare conditions, which are described with a brief accuracy which is rare in a textbook. The order of the chapters and sections is open to criticism. Thus the first chapter contains a series of valuable general principles, which are, however, placed in a remarkable order so that succeeding paragraphs are headed, "The Position of Neutral Muscle Pull," "The Portable X-ray Apparatus," "Ankylosis," and "Referred Pain." Again, the chapters on tuberculous disease are interrupted after tuberculosis of the spine, whilst chapters on bone-grafting, Roentgenology, and the electro-operative bone outfit are inserted. However, these vagaries do not detract from the general excellence of the book, and it may be said that the education of the up-to-date orthopaedic surgeon is incomplete until he has studied it.

Mr. P. B. Roth's *Orthopaedics for Practitioners*³ is a book of a very different sort. For the most part it consists of a brief but clear account of the more common deformities, and the principles of their treatment; but it also is open to the criticism that it is in many respects too personal. The author is too apt to condemn off-hand all those methods of which he does not approve. Scoliosis is to be treated by gymnastic methods; correction in structural cases is, in Mr. Roth's opinion, impossible, and therefore must not be attempted. Such views, if extended to the whole of surgery, would stop all progress. Moreover, certain methods accepted by most surgeons are subjected to equally brief condemnation, and in several instances if the student accepts the author's views without question he might find himself in difficulties with an unbiassed examiner. This work again, then, but for different reasons, needs to be read in a critical spirit; if allowance is made for the individuality of the opinions put forward, it may be recommended as a good elementary manual for the student and practitioner.

³ *Orthopaedics for Practitioners*. By Paul Bernard Roth, M.F., Ch.B., F.R.C.S. London: Edward Arnold, 1920. (Demy 8vo, pp. 195; 57 figures, 10s. 6d., net.)

THE SEX COMPLEX.

In the second edition of his book *The Sex-Complex*⁴ Dr. BLAIR BELL has made such additions and amplifications as serve to bring it up to date. Despite its vastness and complexity the subject of endocrinology is so fascinating that in the last few years a literature, which is really far too great in bulk, has grown up around it, and it has become a labour worthy of an intellectual Hercules to thresh the grain from the chaff. Verily there is scarcely a subject in medicine about which the same could not with some justice be said in these days, but in regard to this particular one the necessity of a finely balanced judgement in making and in interpreting both the experiments and the clinical observations which must form the foundation of any real progress is particularly apparent, and a large percentage of the literature might with advantage be "scrapped." With feelings such as these one comes to Dr. Blair Bell's book with a sense of refreshment, for here is a successful effort to produce as much of order as is at present possible out of the chaos in one portion of the vast field. Gynaecologists in particular will welcome the work, for in every chapter there is food for thought, and for reasoned speculation as to the probable future developments of their art in relation to functional diseases.

Compared with the first edition, the present volume differs mainly in the matter of additions. The appendices to the former have been embodied in the text, and perusal has been facilitated by the introduction of subject indexes in the margin. The discussion of sexual and reproductive psychoses and neuroses has been considerably elaborated, and the author is to be congratulated on the courage with which he has tackled a delicate and thorny question. We notice that he has given up his former view that the uterus might prove to be an organ of internal secretion. He now regards "uterin" rather as the external secretion of that organ. The claims of the placenta to a place amongst the hormonopoeitic glands he also effectively disposes of. All recent reliable gynaecological researches point to the correctness of the view which Dr. Blair Bell emphasizes as to the absolute interdependence of the individual metabolism of a woman and her reproductive metabolism, and in this work he produces much evidence to support his well known contention that in the calcium metabolism is to be found the key to the problem of how the two are linked together.

We hope that the author will reconsider his decision, as stated in his preface, not to publish another edition. This is the sort of book of which gynaecology requires a new edition every four or five years.

A NATURALIST'S STUDY OF SLEEPING SICKNESS.

IN 1910 Dr. G. D. HALE CARPENTER was sent by the Tropical Diseases Committee of the Royal Society to Uganda to study the tsetse fly *Glossina palpalis*, which had been known since 1902 to be the carrier of sleeping sickness. From February, 1911, to the outbreak of war, with an interval in England, his time was spent on the islands in the north-west portion of the Victoria lake. In a book recently published, *A Naturalist on Lake Victoria*,⁵ he gives an account of his studies on the fly and records a number of observations on the fauna of the islands. These islands, which vary in size between the area of Rutlandshire and mere rocks, were at the close of the last century supporting a thriving population, but the sleeping sickness epidemic, the existence of which first became known in 1901, carried havoc among the inhabitants, and with a view to saving the remainder the Government, about 1907, removed them all. Apart from their beauty, the islands have an advantage over the mainland in that malarial mosquitos are rare—Dr. Carpenter's party never suffered from fever—and the ticks that suck and incidentally infect cattle, as well as the dreaded *Ornithodoros*, are nearly if not altogether absent; so that apart from tsetse

⁴ *The Sex-Complex. A Study of the Relationships of the Internal Secretions to the Female Characteristics and Functions in Health and Disease*. By W. Blair Bell, B.S., M.D. Second edition. London: Baillière, Tindall, and Cox, 1920. (Roy. 8vo, pp. 269; 61 plates, 21s. net.)
⁵ *A Naturalist on Lake Victoria, with an Account of Sleeping Sickness and the Tsetse Fly*. By G. D. Hale Carpenter, D.M., B.Ch. London: T. Fisher Unwin, Ltd., 1920. (Med. 8vo, pp. 357; 87 figures, 2 plates, 1 map, 4 charts, 28s. net.)

they are desirable both for man and beast. Knowledge of their natural history, therefore, should be of value as well of interest.

In the first chapter a historical account of sleeping sickness is given, beginning with the description by John Atkins, surgeon, published in 1742, and coming down to the great epidemic in Uganda, which is said to have carried off 200,000 natives, and the more recent discovery of the disease in a rather different form to the south, "rhodesiense sleeping sickness," so called from the specific name given to the trypanosome. The next chapter deals with the natural history of the disease, and we find a description of the situtunga antelope, *Tragelaphus spekei*, believed to be a natural host of the "human" trypanosome in that region, and hence an essential link in the chain of endemicity. As one of the results of the depopulation the situtunga, being good swimmers, invaded several islands, where they were previously unknown, and in this way Dr. Carpenter accounts for the infection of three of his native employees. In the chapter on the natural history of *Glossina palpalis* the author incorporates his work for the Royal Society published in the Sleeping Sickness Reports. He studied especially the breeding places, the fly's foes, and the fly's food. He showed that the fly feeds chiefly on the varanus lizard, an amphibious creature which reaches a length of six feet; to a less extent it feeds on the crocodile, the insect avoiding the formidable barrier offered by the scaly skin by choosing an eyelid; even on islands wheresitutunga are present only one-fourth of the fly's food is obtained from them. The favourite breeding places, Dr. Carpenter found, are raised shaded beaches, well above the water line. He devised a plan of constructing artificial or decoy breeding grounds so attractive that they are preferred above all other places; by a periodical collection of pupae he hopes that an appreciable impression may be made on their numbers. The fly's enemies are not numerous, and there seems to be little likelihood that the state of equilibrium now reached can be upset in this way, unless it be by the aid of parasites of the pupae. The Uganda canoe is described as "a link between a dug-out and a built vessel," but it served for a tour among the northern islands with Mr. Fiske, who was in Uganda on a like mission. The object of the voyage was a comparative survey of the islands, and note was taken of the butterflies "as some sort of index to the general suitability of an island for insect life." In some islands the webs, several feet in diameter, of great spiders, a species of *Nephila*, were so abundant as to make progress difficult as well as unpleasant. Tsetse was caught on nearly all the islands, and pupae were found on one as small as 20 by 50 yards. There is, Dr. Carpenter says, no exchange of fly between even adjacent islands; they do not cross open water.

In the course of a description of the fauna, the hippopotamus, monkey, otter, mongoose, bat, and situtunga are mentioned. The last, it is said, is multiplying rapidly; it browses on bushes near the water (where the fly feeds upon it) instead of, as elsewhere, keeping to the swamps, and with the change in its habits there seem to be some modifications in its structure—changes in the horns and hoofs. The birds described are numerous, but we must not tarry with them. Crocodiles were scarce, and this was attributed to the absence of man; the varanus preys on crocodile eggs, the natives hunted the varanus for its skin. In the absence of man the varanus has multiplied, and the crocodile families have decreased; from one nest there disappeared in seven days seventy-six eggs. In the description of snakes, which include poisonous snakes and pythons, it is said that the booming noise of the crowned crane is put down by the natives to the puff adder.

In recording his observations on the coloration of insects Poulton's classification into apatetic or "deceitful" colours, and sematic or "warning" colours, is adopted. Apatetic colours are procryptic or anticryptic. Procryptic colouring conceals its wearer from danger—for example, a green grasshopper among grass—and in these instances, attesting the action of natural selection, there are neuromuscular changes as well. Anticryptic coloration enables animals to obtain their prey: instances are some mantidæ. The consideration of aposomatic coloration, bright colours which are regarded as "warning," leads on to the subject of mimicry, to which this chapter, and especially the next on the polymorphic butterfly *Pseudacraea eurytus*, form a

valuable contribution. Dr. Carpenter, by breeding from known individuals, succeeded in establishing this butterfly as "one of the greatest examples of mimicry in the world" (Poulton). The concluding chapters treat of hymenoptera and sundry insects. A locustid, known to the natives as "semukutu," is of medical interest in that when handled it ejects from the side of the thorax a stream of clear yellow fluid with an acrid smell which causes sores on the skin; Carpenter, however, handled many without ill effect.

The book is well illustrated with good photographs; it contains a serviceable map, and, as Professor Poulton writes, a really wonderful body of observations. The style is attractive, and the work will, we predict, find many appreciative readers.

PRACTICAL PHARMACOLOGY.

PROFESSOR DIXON'S *Practical Pharmacology*⁶ is intended for the use of medical students, such as those at Oxford and Cambridge, who do practical work in their pharmacology courses. The experiments described are simple, and have been selected to illustrate well-recognized actions of common drugs in everyday use. None of the experiments are intended for demonstrations on decerebrate mammals. The book contains twelve chapters, dealing with the effects of drugs on organisms and organs of various kinds, their excretion in the urine, and the physical properties of certain medicaments. For the experimental pharmacologist's benefit a useful table of doses for animals is given in an appendix.

Professor Dixon writes clearly and to the point, and his text is full of important practical considerations of service at the bedside as well as in the laboratory. The text is illustrated with a number of serviceable diagrams. The book should be of great assistance to medical students, to whom it may be warmly recommended.

NOTES ON BOOKS.

DR. JOHN FIRST of Philadelphia has prepared a *Manual of Gynecology*,⁷ in which much care has been taken in the description of operations, but in some places it might have been better to give more space to the symptoms and signs of the disease and less to the many methods described for its treatment. The student will greatly appreciate the instructions given for the prescription and application of the drugs so frequently used in palliative treatment, for in many textbooks this important subject is merely outlined, and the student is left in doubt as to how treatment is to be applied in practice. Leucorrhœa and vaginal discharges are discussed in a special chapter, and a good deal of space has been allotted to the consideration of diseases of the heart and rectum, on the ground that affections of these organs must often be treated by the gynecologist. The chapter on electricity, x rays, and radium is well done, but the information given as to organotherapy is chiefly borrowed. The properties of animal extracts are described, and it would appear that the author has a good deal of faith in their value. The book contains many illustrations, none of them exactly artistic, and possesses a good index.

The third edition has appeared of *First Aid in Emergencies*,⁸ by Dr. ELDRIDGE ELIASON; it brings up to date this useful little manual for the lay public by the inclusion of new chapters on methods of fixation and dressing of fractures for transportation derived from the lessons of the war, on recent antiseptics as applied to first aid, and on simple precautions in infectious diseases.

The latest edition of the long established year-book, *Fry's Royal Guide to Charities*,⁹ gives in compact form a classified list of the chief charitable institutions, with date of foundation, annual income, objects, etc., and a special feature is made of the editor's guiding notes.

⁶ *Practical Pharmacology*. For the Use of Students of Medicine. By W. E. Dixon, M.A., M.D., F.R.S. Cambridge: At the University Press, 1920. (Demy 8vo, pp. 88; 16 figures. 7s. 6d. net.)

⁷ *A Manual of Gynecology*. By John Cooke First, M.D. Philadelphia and London: W. B. Saunders Co., 1918. (Cr. 8vo, pp. 453; 175 figures. 12s. net.)

⁸ *First Aid in Emergencies*. By Eldridge I. Eliason, M.D., F.A.C.S. Third edition, enlarged. Philadelphia and London: J. B. Lippincott Co., 1920. (Fcap. 8vo, pp. 243; 166 figures. 7s. 6d. net.)

⁹ *Herbert Fry's Royal Guide to the Principal London and other Charities*. Fifty-sixth new and revised edition. London: The Churchman Publishing Co., Ltd., 1920. (Cr. 8vo, pp. 350. 2s. net.)

REFORM IN MEDICAL EDUCATION.

[FROM A CORRESPONDENT.]

(Concluded from page 72.)

III.

THE TEACHING OF MEDICAL ETHICS.

REFERENCE may next be made to what, in point of time, was the first of the subjects dealt with in the present movement for improvement of medical education. In 1915 the Council adopted the following motion:

"That it be remitted to the Education Committee, with the addition for this purpose of Dr. McVail and Dr. Newsholme, to report to the next meeting of Council on the education of medical students in the ethical relationships of medical practitioners to the State, to their patients, and to each other, and that the Committee have power to make such inquiries on the subject as it deems advisable."

The term "medical ethics" presumably means the application to medical practice of the theory or science of moral obligation. After the Council had adopted the resolution just quoted a letter was addressed to all the teaching bodies, which in most cases elicited the reply that the subject was dealt with in the courses of forensic medicine and public health, but that in a number of instances there had been no regular instruction. The Committee was of opinion that the subject should not be neglected in the education of the medical student, but recognized that the arrangements for conveying the instruction might naturally vary. It therefore proposed that the following general recommendation be added to the resolutions of the Council in regard to professional education:

"Instruction should be given, in the courses of forensic medicine and public health, or otherwise, on the duties which devolve upon practitioners in their relationship to the State, and upon the generally recognized rules of medical ethics. Attention should be called to all notices on these subjects issued by the General Medical Council."

The resolution was adopted by the Council. In November, 1919, it took the matter up again and remitted to the Education Committee to make further inquiries as to the instruction then being given to the students. Replies were received from twenty-six bodies and in general indicated that effect was being given to the recommendation of the Council. The Committee was of opinion, however, that the reminder had been useful in some cases, and a number of the bodies promised to give the subject more attention in the future.

In the communication made to the licensing bodies their attention was directed to the "Warning Notice" issued by the Council so that medical students should have pointed out to them what they had to avoid under its terms. The Notice has had gradually to be made more inclusive as a result mainly of additional legislation. It is divided into six sections: (1) Certificates, notifications, reports, etc.; (2) unqualified assistants and covering; (3) sale of poisons; (4) association with unqualified persons; (5) advertising and canvassing; and (6) association with uncertified women practising as midwives. One object of the Council, therefore, is to prevent a practitioner from heedlessly committing an act which would involve him in a charge of infamous conduct in a professional respect. Section 2 of the Notice, relating to unqualified assistants and covering, is much less necessary now than when it was issued; this offence has receded into the background. The same may probably be said of Section 4—association with unqualified persons. On the other hand, one or two cases under Section 6—association with unqualified midwives—have been before the Council in quite recent years, and the scope of Section 1 in relation to certificates, notifications, etc., has been widened both owing to fresh legislation and to questions arising in connexion with the war.

Certificates required for a variety of purposes are valid only if signed by a qualified medical practitioner. Such certification is therefore a medical privilege, as well as a medical duty, and it is of the utmost importance that the duty be performed with every possible care. There may be now and then a natural tendency in granting a certificate to do something to oblige a friend or a patient, but the most scrupulous rectitude is essential. Fundamentally, the principles of ethics are of universal application to every profession and to every man, but the medical profession, on account of its special responsibilities, has to walk very warily, not merely to avoid infringing the rules of the

General Medical Council, but to maintain the honour and repute of the profession in the public estimation. All this being so, the Council does well to recommend the instruction of students in medical ethics.

In its relation to "infamous conduct in a professional respect," the Council is perhaps at a disadvantage in having no machinery for making inquiries or investigations on its own account. The criminal authorities throughout the country are required to report to the Council every conviction of a practitioner for a felony or misdemeanour, and such cases, after consideration by the President and the Penal Cases Committee, are frequently brought before the Council. In the absence of a conviction evidence of alleged infamous conduct has to reach the Council by way of complaint by any individual or public department, etc., believing itself to be aggrieved, or by a body acting in the interests of the profession, such as the British Medical Association or one of the medical defence organizations.

The Council is also at a disadvantage, at least theoretically, in respect of the fact that it has only one kind of punishment which it can impose. That punishment is very drastic. It is the removal of the name of the practitioner from the *Medical Register*. Since the institution of the Council in 1858, however, this difficulty has been in a considerable measure overcome. Though the facts alleged against a practitioner may be held by the Council as proved, judgement may be suspended and the doctor in question required to present himself at a subsequent meeting of the Council, and to submit evidence by medical practitioners or other persons of standing that he has in the interval been acting in every way in consonance with proper standards of conduct. In such circumstances, after admonition by the President on behalf of the Council, no further action may be taken. Occasionally the period of probation may be prolonged beyond the six months which intervene between one meeting of the Council and another, or a practitioner may be required to come before it for a second time, and to bring further testimony on his behalf. Even where a name is removed from the *Medical Register* it may be restored, on application, after a sufficient interval and on consideration of what may have taken place since the removal of the name. By such expedients—and this statement of them is not exhaustive—the Council has had a measure of success in establishing something equivalent to a series of penalties corresponding to the greater or less gravity of the offence.

REVISION OF THE REGULATIONS AND RULES FOR
DIPLOMAS IN PUBLIC HEALTH.

This is the very latest direction in which the reforming zeal of the Council is manifesting itself. On the last day of the recent session the following resolution was adopted by the Council at the suggestion of the Public Health Committee:

"That the General Council authorize the Public Health Committee to consider and revise the existing regulations and rules for diplomas in Public Health which were originally adopted by the Council on June 1st, 1889, and amended and amplified from time to time, particularly on December 1st, 1911, with a view to bringing the special course of instruction required of candidates for the diploma into harmony with the duties of a modern medical officer of health, which have changed considerably since the resolutions and rules were originally adopted and afterwards amended and amplified."

The Council, it should be pointed out, is in a much stronger position with regard to Public Health diplomas than with regard to qualifications in medicine. As concerns the latter, it has already been observed that the Council can only make "recommendations" to the licensing bodies, and that its ultimate control consists in advising the Privy Council to refuse registration to the licences of any persistently recalcitrant body. As to diplomas in Public Health, however, its power is absolute excepting that, of course, it lies with the licensing bodies to carry out the rules and regulations laid down by the Council. When the rules were originally adopted in 1889 the conception of public health was comparatively elementary. Excepting for infectious diseases and epidemiology in general, it related wholly to matters of environment, to water supply, food and milk supply, drainage, cleansing, ventilation, nuisance prevention and removal, and the like. Within recent years there has been extensive development, and such duties as school medical inspection and treatment, maternity and child welfare, and control of venereal

disease have come within the scope of the Public Health authorities. It is right, therefore, that the requirements for diplomas in Public Health should be correspondingly altered.

The discussion which took place on submission of the motion indicated that the Public Health Committee had in view not merely the question of adding new items to the required course of study, but the question whether at present too much time is not devoted to chemistry and bacteriology, seeing that in practice medical officers of health are not required to carry out this kind of work. They should always be able, however, to appraise the value of reports and certificates by analysts and bacteriologists.

Conclusion.

This completes the survey of the proceedings of the General Medical Council in regard to reform of medical education. It will be seen that the whole curriculum is under review, and that the questions include the raising of the age at matriculation from 16 to 17 years; stiffening of the preliminary examination in general education; a new preliminary examination in the introductory sciences; the subsequent teaching of these sciences in their application to the later stages of study; the inspiration of the entire curriculum with the principle of maintenance of health, and the preventive treatment of disease in its earliest and most trivial manifestations; revision of every section of the curriculum for excision of whatever is unnecessary, and for addition of whatever matters of moment may have hitherto been omitted; co-ordination of the whole educational scheme for avoidance of overlapping and for the due ordering and sequence of the subjects; modification of the examination system by introduction of the candidate's record of work throughout his years of study as an element in determining his admission to the practice of medicine; definite education of the student in the application of the principles of ethics to the sphere of medical practice, along with instruction in his duty to the State, and in the provision made by the State for supplementing the work of the practitioner in respect of health at every stage of life; and revision of the course of instruction and study required for diplomas in Public Health.

The scope of the movement in which the General Medical Council is now engaged could hardly have been wider. It is to be hoped that undue haste and undue delay in arriving at momentous decisions will alike be avoided. There is no doubt that the proceedings of the Council will be watched and its conclusions considered with appreciative interest by the general body of the medical profession

THE NEW INCOME TAX.

WHEN the Royal Commission on the Income Tax issued its very able report we called attention in some detail to the probable changes which it would bring about in the income tax system. As our readers are aware, some of those proposals have been translated into fact, and the payments of tax now being required all over the country are the first to be determined by the fiscal changes effected by the Finance Act of 1920. Income tax has for some years been at such a level as to make a very real inroad on the enjoyment of the income; it represents a surrender to the State of purchasing power only too urgently desired in these days for the legitimate satisfaction of present and future wants, and it is important that demands made by the local officials should not be satisfied until they have been subjected to intelligent examination. Fortunately, the new system is in many respects simpler than the old, and we very strongly advise all taxpayers to see that they understand what they pay before they pay it. This may, and not infrequently does, involve a little trouble, first, in studying the regulations, and second, in clearing up any obscure points or errors with the local officials, but it is time very well spent, and it will, as a rule, be found that the officials are willing to discuss such matters in an intelligent and helpful manner. We propose here to set out the elements of the new system as briefly and clearly as possible.

First of all, the change, radical as it is, does not in any way affect the calculation of the "income" which is to be taxed, professional profits remain assessable on the basis of the average of the three previous years' earnings, untaxed

interest on the basis of the previous year, and so on. What the change does is to sweep away the old system of the two scales of rates—for earned and unearned incomes—rising at each £500 of total income, and substitute for it a new method of raising the effective rate as the total income increases, while at the same time the man with family dependants receives not insubstantial relief as compared with the taxpayer whose income is not required for the support of others beside himself.

1. Earned Income.

Income earned directly by the taxpayer is still dealt with less stringently than unearned, or, as it is now called, "investment" income, but to avoid the complication introduced by a different rate of tax that object is achieved by deducting 10 per cent.—that deduction, however, is not to exceed £200 for any individual—from the earned income, the balance of 90 per cent. being called the "assessable income." Where the income is mixed—that is, partly of each class, earned and unearned—the "assessable income" is, of course, the whole less 10 per cent. of the earned income—for example:

A. has £900 "earned" and £500 "investment income"—that is, his "assessable income" is £900 - £90 + £500 = £1,310.

A clear grasp of this conception of "assessable income" is essential to a proper understanding of the present system.

2. Allowances.

It is important to remember in this connexion that the income limit which formerly applied to this class of relief has entirely disappeared. If the ground for the claim exists, it holds good irrespective of whether the total income of the individual is £300 or £3,000. By way of warning, however, it may be pointed out that these allowances do not apply to super-tax, though they apply to the income tax payable by the same individual.

The allowances are deductible from the assessable income, and may be summarized as follows:

Personal, unmarried	£	135
Personal, married	£	225
Personal, wife, as regards own earnings, additional	£	45
Child—for one, complying with the stated conditions	£	36
Child—for each other one, complying with the stated conditions	£	27
Relative taking care of widower's or widow's child	£	45
Relatives dependent by old age or infirmity, and not having an income exceeding £50	£	25

The revenue authorities have forms containing the declarations required to be made when claims under the above heads are lodged, and we understand that such forms are supplied on application to the office of the local inspector of taxes.

3. Assessable Income.

When such allowances as are due have been deducted from the assessable income the balance is chargeable to the income tax, and it is provided that the first £225 of that balance shall be charged at 3s. in the £ and the remainder at 6s. It is the fixity of the portion—or "slice"—of the income chargeable at 3s. which produces the graduation of the tax. A moment's thought will serve to show that the greater the total income the greater *proportionately* the "slice" paying at the 6s. rate, and therefore the higher the effective rate—that is, the rate arrived at by comparing the total income with the actual amount of tax paid. In passing, it may be remarked that the stiffening of the super-tax accentuates the graduation as regards the higher incomes.

It may serve to make the matter clearer if the method is set out in the form of a calculation as follows:

Amount of total income	£	_____
Deduct one-tenth of earned income	£	_____
Assessable income	£	_____
Deduct allowances	£	_____
Income chargeable to tax	£	_____

Of this amount £225 is chargeable at 3s. and the remainder at 6s. in the £.

Life Assurance.—Under the old scheme the allowance for life assurance premiums was treated in the same way

as other allowances—at any rate so far as “old” policies, that is policies taken out on or before June 22nd, 1916, were concerned—they were deducted from the taxable income so that the payer benefited more or less according as he paid a higher or lower rate of tax. This principle has been preserved by providing that, so far as “old” policies are concerned, an allowance is to be given as follows:

Where the total income does not exceed £1,000, at 3s.
Where the total income does not exceed £2,000 at 4s. 6d.
Where the total income exceeds £2,000, at 6s.

As a result of this, the duty calculated at 3s. and 6s. in the £ has to be reduced by the appropriate amount of the life assurance allowance calculated in terms of actual tax. “New” policies carry a relief at a uniform rate of 3s. in the £ as before.

One or two points remain to be noted. It is provided by Section 17 of the Finance Act, 1920, that the individual claiming the allowance must make a statement of his total income in the prescribed form. The stipulation is presumably intended to prevent an individual who has incomes in different areas being given any particular allowance twice over—a result which might happen when separate returns were being made to different officials. It is possibly this stipulation which has led to the withholding of the allowance in some of the cases which have been discussed in the daily press. Where the total income is under £2,000, it has for some years been the practice to render to the local authorities a statement of the total income, and where that has been omitted by accident or neglect the taxpayer's best course is to make good the omission and obtain a rectification of his assessment as soon as possible.

But where the total income exceeds £2,000 the position is different. In those cases the taxpayers are called upon to make returns to the London office of the Special Commissioners for the purpose of super-tax, and may very reasonably object to supplying similar statements to another official. We understand that in such cases the Special Commissioners have supplied forms of claim to individuals on their books, and, on receiving the declarations back, have notified the person in question as to whether the allowances are being made (1) through the inspector's office against tax payable locally, or (2) by the Special Commissioners themselves by way of set-off from the charge for super-tax. Where the former notification is received it would seem advisable to see that particulars of the revised assessment are supplied by the local inspector.

The advantage of the new system is that income received from investments is in the normal case taxed at 6s. in the £ by deduction, and usually properly so taxed. So long as the various “allowances” and the relief afforded by the £225 at 3s. provision are made against that portion of the income which is not taxed at its source, and therefore comes before the officials for assessment, then the amount of the investment income is immaterial, and the old trouble of determining on which side of a particular £500 limit line the total falls is avoided.

The new system has strong recommendations and obvious advantages, and there is good ground for hoping that it will materially assist the ordinary taxpayer to understand not only how much he has to pay, but also how the amount is properly determined. That consummation will be brought much nearer by a little trouble and thought on the part of both the taxpayer and the revenue authorities.

AMERICAN CONGRESS ON VENEREAL DISEASE.

At the International Health Congress held at Cannes in April, 1919, the delegates representing the five principal allied nations called for regional conferences to take up the campaign against venereal diseases throughout the world. The first of such conferences was held last month in Washington, and among the 400 delegates were representatives from Great Britain, Canada, Argentina, Brazil, Chile, Ecuador, Cuba, Honduras, Mexico, Paraguay, Porto Rico, and Czecho-Slovakia. The second will be held next May in Copenhagen, and will be attended by delegates from all the Scandinavian nations and from Great Britain and

Holland. Later conferences will probably be held in 1921 in Paris and in London, and it is expected that one or both of these will be attended by delegates from Germany.

The meeting in Washington is generally held to have been successful; there were no set papers, and few, if any, set speeches. The work was directed by a general committee selected from the delegates by Dr. W. H. Welch, the President, whose object was to gather together in this committee those who, by their studies, experience, and attainments, and by their relations to other official and non-official bodies, could speak with authority on various phases of the work. Its membership thus included clinicians, pathologists, sociologists, syphilologists, gynaecologists, social workers, and psychiatrists. The committee was divided into twelve subcommittees, each being set to consider a special group of problems formulated in a series of questions. In the afternoons the Committee sat as a whole and discussed seriatim the reports furnished by the twelve groups at the morning sessions. While the committee meetings were in progress the remaining 300 delegates assembled in the auditorium of the United States National Museum to hear papers and hold discussions. In the evenings the delegates met to receive the findings of the General Conference Committee, and many of these were keenly debated. The work of editing the resolutions reached by the Conference has not yet been completed, but the general way in which the questions were put forward and answered is shown by the following resolutions adopted in plenary session.

With respect to the use of the Wassermann reaction it was resolved that:

The blood Wassermann reaction should not be used as a sole guide to the duration of a syphilitic infection. The blood Wassermann reaction should not be used as the sole evidence of the effectiveness of a particular drug or method of treatment. The blood Wassermann reaction should not be used as the sole evidence of “cure” no matter how many times repeated.

A further resolution declared that:

The complement fixation test has not yet been shown to be of value in the diagnosis of doubtful cases of gonorrhoea. It is possible, however, that the precipitin test recently reported by Meader and Robison may be of great value.

The Committee enumerated the advantages of working venereal disease clinics in conjunction with other clinics.

Exhibits and demonstrations were features of the work of the Conference; included in these were the methods of the United States hygienic laboratory in testing salvarsan, the application of the methods of social hygiene by the Washington police, and methods of treating venereal diseases at the United States Naval Hospital. Among the exhibits were wax models of the Army Medical Museum showing phases of venereal disease, and the social hygiene car for educational work now in use in North Carolina was brought to Washington for inspection by the delegates.

THE MEDICAL RESEARCH COUNCIL.

The report of the Medical Research Council for the year 1919-20¹ is the first annual report of the Council, and includes the work of the Medical Research Committee (National Health Insurance) for the half-year ending March 31st, 1920, and of the Medical Research Council, which was incorporated by Royal Charter on April 1st, 1920, to continue the labours of that Committee, for the half-year ending September 30th, 1920. In spite of the changes in constitutional and administrative control there has been no breach in the continuity of the medical research work supported by parliamentary grant; but the new powers vested in the Council, which are such as have not before been assigned to any body of scientific men, give it fuller opportunities for securing that continuity of policy which is vital to the work of scientific research, and give it wide limits of intellectual and administrative freedom. While the Council is subject to the direction and control of a committee of Ministers responsible to Parliament, its powers are exercised in a position under the Privy Council in which not only is it brought into direct relation to the Ministry of Health for England and Wales, and the corresponding departments in Scotland and Ireland, but also it can bring more effectively the medical research services throughout the kingdom into relation with the needs of other departments of State, and

¹ Report of the Medical Research Council for the Year 1919-20. Cmd. 1033. London: His Majesty's Stationery Office, 1920. (91. new.)

with similar systems of research work done in, or for, the various parts of the Empire. The provisions of the Charter make, in fact, a constitutional link of a valuable and novel kind between the scientific forces of the country and the State. As the committee of the Privy Council is under the obligation of consulting the President of the Royal Society before appointing any new member of the Medical Research Council there is a definite and formal link between the Society, as the great unofficial representative body of science, and the official State scientific organization.

Finance.

The increased financial grant of £125,000 made by Parliament for the work of the Council was announced too late in the year to have much effect on the expansion of the schemes already framed, but it has been allocated as follows:

	£
Costs of administration	7,800
National Institute for Medical Research, Hampstead	39,000
Equipment of Institute	18,000
Grants to investigators at universities and elsewhere	60,000

In addition, however, to the lateness in the year of the announcement of the increased grant, other factors are at present limiting the directions and scope of the work which the Council can subsidize. The fall in money value has rendered the increased financial provision more nominal than actual, and the costs of labour and of scientific apparatus have increased in larger ratio even than the decline in money value. In addition, the effect of the war on the universities has caused a dearth at present of men who otherwise could be at the stage of carrying out independent investigations; not only must the investigator be endowed with eagerness and some scientific ability, but he must possess also the requisite equipment in training.

From the report it is apparent that the Council is working in close relation with, and in the interests of, the other departments of State, particularly, as is natural, with the Ministry of Health. This is seen especially in the schemes of work upon tuberculosis and venereal diseases, and in physiology as applied to hygienic measures: less formally the Ministry suggests the need for any new inquiries, in the systems of research work under the Council, by which administrative medical measures may be guided. At the instance of the Home Office, again, the Industrial Fatigue Research Board has been appointed jointly by the Medical Research Council and the Department of Scientific and Industrial Research, in order to direct research on the subject of industrial fatigue on systematic lines, with a view to improving the health and efficiency of the workers; also at the instance of the Home Office new researches into miner's nystagmus have been instituted. For the Board of Trade the control of certain dangerous drugs, and the research work upon which it is based, are still continued. The research grants made by the Council in clinical medicine have been so adapted to the grants for teaching in medicine, formerly made by the Board of Education, as to secure the effective linking of research work with higher teaching. With this in view, the secretary of the Council, Sir Walter Fletcher, was appointed an assessor to the University Grants Committee.

Profitable Lines of Research.

The possible value of research from the purely financial point of view is demonstrated by the fact that after investigations on cardiology, pursued by Dr. Thomas Lewis under the auspices of the Council, for the Ministry of Pensions, approximately £46,000 annually has been saved on cardio-vascular pensions assessments in the London region alone. Recently the Development Commission, in consultation with the Council, has appointed a committee to advise upon the best methods of advancing the scientific study of the diseases of animals, and the hope is entertained that this may lead to the great resources of human pathology, in men, in methods, and in results, being utilized more fully for the study and prevention of animal disease, and in turn that human medicine may gain from the wider outlook and opportunities of comparative pathology.

Research work is being carried out in the direction of setting up official standards of value and authenticity for the numerous biological preparations, serums, and the like

used in medical practice. In regard to such standardization too much dependence was previously placed by this country on the work of public or private laboratories in other countries, chiefly in Germany. The standard, for instance, of the antidiphtheritic serum used in all our fever hospitals, and formerly supplied from Frankfurt, was entirely, during the war, dependent on the fact that the Government of the United States furnished such a standard, while the maintenance of the standard of anti-tetanic serum was likewise due to American enterprise and generosity. For such obvious purposes, as also for the more fundamental purposes of scientific research, biological standardization was urgently required, and both at the institute at Hampstead and the Standards Laboratory at Oxford important work is being done in this direction. The committee appointed by the Council to advise upon improvement and systematization of pathological methods is also continuing its work.

Special Investigations.

In regard to research on specific subjects the period covered in the present report has been one of reorganization. The investigations undertaken for reasons arising directly from the war have now practically come to an end, and in many instances this has been a signal for development along broader lines, and a more general application of the great advances in knowledge in special directions that were gained during the war.

To take one example: in tuberculosis, for instance, the changed conditions have enabled the Council to organize research along the manifold lines of attack offered by the general problem—on the morphology of the tubercle bacillus, on the pathology of infection, on problems of immunity against infection, on the classification of pulmonary tuberculosis, on the early diagnosis of tuberculosis, on the chemio-therapeutic treatment of tuberculosis, on electrical sterilization of milk, and on milk and tuberculosis infections, etc., investigations carried out by different workers in different parts of the country. Other subjects similarly organized for research include cerebro-spinal fever, influenza and pneumonia, rheumatic fever, venereal diseases, problems of child life, disorders of growth, accessory food factors (vitamines), disorders of the cardio-vascular system, the medical problems of flying, biochemistry and chemio-therapy, "status lymphaticus," and causes of unexplained death, and many others.

Occupation was resumed during the year of the building and grounds at Mount Vernon, Hampstead and the several departments which during the war had been isolated in temporary quarters were brought together in accordance with the original design. The expected advantages of daily intercourse between bacteriologists and biochemists, physiologists and statisticians, and others, are being realized, and are giving opportunity for the exchange both of intellectual stimulus and of technical help; free intercourse takes place also between those engaged in schemes of investigation inside the institute and outside it, and several workers from outside laboratories and members of other Government services have been temporarily attached to the institute.

There are many problems in medical science which can best be studied, and some indeed which can only be fully studied, the Council believes, by men engaged in professional practice, who are in a position to follow the signs and results of disease and the effects of given treatment in suitable cases from their earliest to their latest phases. Studies, however, of this kind can only be successful if the professional man has some leisure and if he has access at need to laboratory and other resources, like those of a well-equipped hospital. Studies, again, made in hospital practice may be given the same kind of extended value as those possible to a man in private practice, if the cases can be received in their earliest stages and followed to the end by a proper system of after-history records. The Council expresses the opinion that until some effective revision takes place, both of the conditions of medical practice and of hospital organization, it must remain difficult or almost impossible to arrange for the combined and long-continued observations necessary for successful research work in this field. In this connexion the Council states that it is not only following with sympathy and interest, but has given some assistance to, the Research Institute established by Sir James Mackenzie at St. Andrews.

British Medical Journal.

SATURDAY, JANUARY 15TH, 1921.

PROBLEMS OF MEDICAL EDUCATION.

THE articles in our issues of this month (pp. 20, 52, 88) summarizing the deliberations of the General Medical Council on the burning subject of the reform of medical education, deal with questions of great importance to the future of medicine. They supplement, and indeed in some respects endorse, opinions previously expressed in Sir George Newman's memorandums, "Some Notes on Medical Education in England" (1918) and "An Outline of the Practice of Preventive Medicine" (1919), in the Edinburgh Pathological Club's "Enquiry into the Medical Curriculum" (1918), and by Sir James Mackenzie in various addresses, and particularly in "The Future of Medicine" (1919).

That the first and most important aim of medicine is the prevention of disease may perhaps be said by some to be a truism that is not only recognized but acted upon in many directions, such as infant welfare centres, the school medical service, industrial hygiene, and the social service inspired by the enthusiastic energy of Dr. R. C. Cabot, of Boston, Massachusetts; but the truth is that little more than a beginning, promising as it is, has yet been effected. The scope and meaning of "preventive medicine" perhaps require consideration, for to some minds this term still suggests mainly the activities of the medical officer of health and a specialized branch of medical practice which only incidentally concerns the rank and file of the profession. This mental attitude is probably due to the recollection of the leading part played among the nations by this country half a century or more ago in the organization of a public health system under the leadership of Chadwick, Simon, and others, and in part to the prevailing tone of instruction in medical schools, in which preventive medicine is chiefly associated with the lectures and courses in public health. Great as is our debt to sanitary science, especially for the disappearance of many of the more striking epidemic scourges, there is an enormous amount to be accomplished in the wider field of preventive medicine, and this can only be done when the whole profession, not content with realizing its share in this duty, takes an active part in carrying it out. For the proper solution of the problem a more thorough knowledge of the etiology of disease is essential, and though bacteriology and biochemistry are clearing some of the ground, the initial symptoms and stages, the environment, and the disposing factors have as yet been imperfectly explored. In this, as Sir James Mackenzie insists, the general practitioner must play the leading part. No doubt a great deal of the work of a general practitioner is concerned with preventive medicine, but he has to rely much on his own experience and is mainly self-taught; hence, to put him in the best position to carry out this duty, he must be bred up on these lines from his earliest student days: his whole education, from the preliminary sciences onwards, should be permeated with a conception of the prevention as well as with that of the recognition and cure of disease. The replies received by the General Medical Council from thirty medical schools showed that present-day teaching

does not sufficiently meet these requirements. It appears to us that this may, to some extent, be explained as follows: As the outcome of specialization and extension of medical education, the teachers of the preliminary sciences are usually not now, as they formerly were, medical men, and the teachers of the intermediate subjects are no longer in such active touch with medical practice: their natural tendency, therefore, is to lay more stress on the principles of the science than on—what may, from their point of view, appear to be a narrower aspect—the practical bearings on the art of medicine. There is, and rightly, a revulsion against this condition of affairs, and efforts are being made to counteract the tendency to keep the medical curriculum in watertight compartments. In the United States of America this aim is being followed to an increasing degree; and although the preliminary subjects are taught before the curriculum begins, there are throughout the curriculum further courses whereby the earlier subjects are correlated with the clinical work: and in this country Professors Elliot Smith, Arthur Keith, and apparently Professor R. J. A. Berry in Australia (vide p. 75), have shown that anatomy—which unfortunately is an outstanding example of the academic method of teaching—can be made a living practical part of medicine.

After full discussion of the requirements for the teaching of the preventive aspects of medicine the Education Committee of the General Medical Council raised the question of the revision of the whole of the medical curriculum, and recommended important alterations in it, which should go some way towards producing the medical man equally able to ensure a healthy condition of the public as to cure disease when it does arise. While the minimum standard of general education required for registration is to be brought up to the level demanded in other learned professions, and the minimum age is to be raised from 16 to 17, the student should before registration have passed an examination in elementary physics and chemistry, and may receive sufficient instruction in biology to enable him to pass an examination in this subject immediately after his registration as a student. In this way the five years of the curriculum is for practical purposes prolonged, but the more complete correlation of these sciences with medicine is provided for by the recommendation of further specialized courses during the curriculum. Another important suggestion is directed at the examination bugbear which, though necessary for the sake of the weaker brethren, so often penalizes good men, and, it may be added, handicaps the teachers: this recommendation is to the effect that the record of the student's preparatory study may, at the discretion of the examiners, be taken into account in deciding the result of the examination. This is the thin end of the wedge, and it may reasonably be expected that experience will justify, as a further step in the same direction, the regular inclusion of marks, allotted on a report of the student's work, in the mark sheet of the examination.

In the third part of the article, published this week, some account is given of the views expressed by the General Medical Council and the authorities of the medical schools on the teaching of medical ethics, a matter in which the British Medical Association has taken particular interest. Many years ago an Ethical Branch was formed in Shropshire, and one result of its labours was the publication of an Ethical Code, edited by its honorary secretary, the late Dr. de Styrac. This code was very useful in its time in various ways; it was, for example, of great

assistance to this JOURNAL in its endeavour to help individual members who had become involved in disputes with colleagues or hesitated as to the course of conduct they should pursue in special circumstances. Later on, a former Chairman of the Council of the British Medical Association and member of the General Medical Council, the late Dr. Saundby of Birmingham, gave a great deal of attention to the subject, and eventually published a book, *Medical Ethics*, which was of very considerable service to the profession. Later the continuance of the publication of advice in the JOURNAL was rendered superfluous by the setting up of the Central Ethical Committee to deal with questions and difficulties of this kind. It is, of course, true that the principles of medical ethics are identical with those recognized by other professions, but they are applied to a special set of circumstances which, moreover, are of common occurrence in an almost identical setting. There are therefore certain general principles more or less peculiar to medicine which can be taught to medical students. The realization of these facts led the British Medical Association as long ago as 1905 to suggest to the authorities of the medical schools the desirability of arranging for a short course of lectures every year on medical ethics, drawing the attention of students to the principles on which it is founded. It had been proposed recently to repeat this suggestion, but in view of the action taken by the General Medical Council this is now considered superfluous.

LETHARGIC ENCEPHALITIS.

LETHARGIC ENCEPHALITIS, both in its clinical and pathological aspects, has recently been the subject of discussion in our columns on more than one occasion. We have endeavoured at various times to show that the increasing multiplicity of clinical types described does not make for any clearer appreciation of the problems presented by this disease. Special reference has been made in these columns to the recent work of French observers and to the discussions in the Académie de Médecine in Paris during which currency was given to the term "lethargic encephalitis." When M. Netter first dealt with the matter, just a year ago, he laid it down that the cardinal symptoms were fever, somnolence, and diplopia, followed by temporary paralysis of accommodation. The term "lethargic" seemed then appropriate, but recent experience has shown it to be misleading. Pathologically the disease seems to be an acute infiltrative encephalo-myelitis, due, if we may accept recent researches in New York and Paris, to a filtrable virus which can be cultivated by Noguchi's method.

Walshe,¹ in a recent paper in *Brain*, has presented a valuable study of the symptom-complexes of the disease, and in our view rightly deprecates a purely symptomatic classification, which is likely to reach quite unwieldy proportions. Following the teaching of Hughlings Jackson he would distinguish clearly between "positive" and "negative" symptoms, "positive symptoms being the expression of exalted function either from irritation or from loss of higher control, and negative symptoms expressing depression or loss of function from destruction of nervous tissue or otherwise." The symptoms, then, of lethargic encephalitis may be classified into two groups: (a) general, or signs of toxic infection, and (b) nervous, these being further divided into general and focal. The nervous symptoms may be either positive or negative. Thus, for example, lethargy or coma and paralyse are

negative symptoms, involuntary movements positive. On this basis of classification the earlier cases described—and, indeed, the classical picture—may justly be recorded as essentially negative, for the principal symptoms were lethargy and ocular paralyse.

More recently, however, positive symptoms have figured with greater prominence in the symptomatology of the reported cases. Of this group of positive symptoms myoclonus has attracted much attention. Originally described by Sicard, this particular syndrome has lately been reported with increasing frequency, though, as Walshe states, many different types of involuntary movements have been included under the name of myoclonus. An interesting feature of this group has been the combination of severe neuralgic pains with the myoclonus. Seven new cases are reported by Walshe, each exemplifying a different clinical type of the disease. The description of these cases alone shows the futility of establishing a permanent classification of the disease on a purely symptomatic basis. We have nothing but praise for this exposition of the clinical aspects of lethargic encephalitis.

From reports lately published, both in the medical and lay press, it seems probable that we may expect a recrudescence of the disease. This article in *Brain*, therefore, comes at a peculiarly opportune moment. Wilfred Harris, to whose clinical acumen we owe one of the earliest reports on the appearance of this disease in recent times, has already written to warn our readers of the possibility of such a recurrence.²

We may add a word of warning on the numerous possibilities of diagnostic error which are offered by this protean disease. In every case the most scrupulous care should be taken to exclude the presence of other inflammatory or vascular diseases of the central nervous system, and the more so since as yet no specific treatment for lethargic encephalitis exists, while valuable remedial agents are to hand in such conditions as syphilis of the nervous system or cerebro-spinal fever. Knowledge as to the probability of eventual recovery is still very inadequate. There must be by now in the country sufficient clinical material on which a real inquiry into this very important point could be instituted. We would like to suggest this as a field of study to future observers. The occasional occurrence of relapses, again, is another important point on which more information is desired. Should this country be so unfortunate as to experience another epidemic of lethargic encephalitis it is to be hoped that a concerted effort will be made to collect all the available information—epidemiological, clinical, and pathological—so that definite conclusions may be reached.

ANNUAL MEETING AT NEWCASTLE. PATHOLOGICAL MUSEUM.

THE Committee appointed to organize the Pathological Museum in connexion with the Annual Meeting of the British Medical Association at Newcastle-on-Tyne in July, 1921, proposes to arrange the material under the following heads: (1) Exhibits bearing on discussions and papers to the various Sections. (2) Specimens and illustrations relating to any recent research work. (3) Instruments relating to clinical diagnosis and pathological investigation. (4) Individual specimens of special interest or a series illustrating some special subject. It is proposed to gather together a series of exhibits illustrating the pathology of individual cases. Such exhibits will include a brief clinical history of the case and mounted

¹ Walshe, *Brain*, vol. xliii, Part 111, 1920.

² Wilfred Harris: *BRITISH MEDICAL JOURNAL*, 1921, i, 47.

specimens of the different organs and tissues illustrating the pathological changes and the correlation of the lesions. Other interesting specimens will be welcomed. The chairman of the Pathological Museum Committee is Professor Stuart McDonald and the Honorary Secretary is Dr. A. F. Bernard Shaw, Pathological Department, College of Medicine, Newcastle-upon-Tyne. The museum will occupy a central position in the same building as that in which the Sectional work is carried on, and will be easy of access. Every care will be taken of specimens, and the contents of the museum will be insured. It is hoped to make arrangements for exhibitors to demonstrate their specimens.

EXPERIMENTAL INFLUENZAL INFECTION.

In the course of an extended research into experimental pneumonia F. G. Blake and R. L. Cecil,¹ working in the bacteriological laboratories of the Army Medical School, Washington, have obtained results bearing directly on the pathogenicity of the influenza bacillus. Hitherto most of the animal experiments have consisted in subcutaneous, intraperitoneal, or intravenous injection of the influenza bacillus, and attempts to produce infection via the respiratory tract have usually failed. As there is no satisfactory method of distinguishing saprophytic from pathogenic varieties of the Gram-negative haemophilic bacilli to which the name *Bacillus influenzae* is at present indiscriminately applied, a strain isolated from an empyema was used for injection into the upper respiratory passages and intratracheally into the lung. But as preliminary intratracheal injection of a monkey failed to produce any evidence of infection, the virulence of the strain was raised by successive passage through white mice and monkeys; further, on account of the extraordinary rapidity with which the *Bacillus influenzae* may lose its virulence when subcultured outside the body, special efforts were made to inoculate the respiratory passages and lungs of monkeys with cultures obtained with as little delay as possible from the passage monkeys. Twelve monkeys received applications of these cultures on the mucous membranes of the nose and mouth, and manifested an acute infection, with profound prostration, absence of leucocytosis or leucopenia, essentially similar in clinical respects to human influenza; 5 monkeys developed acute suppurative inflammation of one or both antra, and 2 monkeys bronchopneumonia yielding a pure culture of the influenza bacillus. The application of the culture medium, from which the influenza bacilli grown in it had been separated by centrifugalization, to the oral and nasal mucosa of a monkey failed to produce any toxic effects. Ten monkeys received intratracheal injections of these cultures of enhanced virulence, and 7 developed bronchopneumonia, 2 tracheo-bronchitis, and 1 resisted infection. The bronchopneumonic lungs from 3 of the 7 monkeys gave pure cultures of *B. influenzae*, and in the other 4 cultures were sterile, showing that the infection had died out. From a minute study of the morbid changes it appears that experimental influenza and bronchopneumonia resemble influenza and influenzal bronchopneumonia in man. The morbid lesions—intense engorgement, haemorrhage, oedema, purulent bronchiolitis, scattered patches of peribronchiolar consolidation and the resulting emphysema and bronchiectasis—described by W. G. MacCallum and Wolbach in man, are paralleled by those found in the experimental monkeys; but the lesions are less severe than in the human cases, as indeed might be expected in view of the great severity of the epidemic and the probable exceptional virulence of the influenza bacillus at that time. There is a difference in the pathogenesis of influenzal lung lesions, whether spontaneous or experimental, on the one hand, and those due to the pneumococcus and the streptococcus on the other hand; the pneumococcus and *Streptococcus haemolyticus* cannot initiate an infection of the normal mucosa of the

upper respiratory tract in monkeys, but they penetrate the bronchial mucous membrane at once and spread rapidly through the perivascular lymph spaces to the alveolar walls in all parts of the lobe of the lung. The influenza bacillus has not this invasive power, is rarely found in the lymphatics, blood, or interstitial tissues, and causes focal lesions by extending by continuity along the bronchial tubes. Well marked hyperplasia of the thymus was found in monkeys with *B. influenzae* infection, the gland being enlarged, firm, and with a peculiar pinkish-yellow flesh-like appearance. This condition, which has not been recognized in human influenza, appears to be merely part of a general hyperplasia of the lymphoid structures in the cervical and thoracic regions.

BLACKWATER FEVER.

PROFESSOR L. S. DUDGEON'S study of 100 cases of blackwater fever in the Balkans during the years 1916-18¹ is rich in the observations of an experienced pathologist, and contains interesting criticisms of the hypotheses suggested for the solution of the vexed question of its pathogeny. Turning first to the aspects of clinical pathology: jaundice was present in 20 out of the 49 cases with full notes; some of the remaining cases had a yellowish discoloration of the conjunctiva, like that seen in pernicious anaemia, but examination of the blood plasma or serum did not show the presence of bile pigment. Emphasis is therefore laid on the importance of checking clinical impressions by laboratory tests, and a method consisting of evaporation of the blood to a dry sticky residue and then applying Guclini's fuming nitric acid test for bile pigment is described. Numerous observations proved that the red blood corpuscles are not unduly fragile, and that the blood does not contain auto- or iso-haemolysins; on the other hand, an active haemolytic substance or substances can be extracted by alcohol or acetone from the tissues of fatal cases, and to a lesser extent from the urine, but cannot be obtained from the tissues in other conditions, including malaria. These extracts haemolyze human and animal red cells, but the urine from cases of blackwater fever does not haemolyze the red cells of man or sheep, and its injection into rabbits did not produce any bad effects. In connexion with these observations reference is appropriately made to Dr. Andrew Balfour's ingenious suggestion that blackwater fever may be due to the action of a haemolysin—introduced by a biting insect—on red blood corpuscles already enfeebled in some way, usually by malaria, but sometimes by tick fever. A malarial history was forthcoming in all the 100 cases, and it is shown that blackwater fever is at its height at the period of the year when the death rate from malaria is lowest. Film preparations of the blood during the paroxysm of blackwater fever were made in 40 of the 100 cases, and in 42 per cent. of these there were malarial parasites present, 60 per cent. of these being malignant rings or crescents. Spirochaetes were never detected in the blood or urine; and the experience with the Wassermann reaction and microscopic examination of the tissues after death did not lend any support to the view that syphilis, which is causally related to paroxysmal haemoglobinuria, plays any part in the etiology of blackwater fever. The well known hypothesis that quinine poisoning explains the disease was investigated in several ways, but neither consideration of the clinical history in the cases specially analysed from this point of view nor some animal experiments provided any evidence in its favour. Thus, rabbits rendered intensely anaemic by the intravenous injection of immune anti-serums did not show haemoglobinaemia or haemoglobinuria when treated with various preparations of quinine intravenously or intramuscularly; and complete ligation of the ureters in rabbits while quinine was being given or had been given did not induce a condition in any way

¹ F. G. Blake and R. L. Cecil: *Journ. Exper. Med.*, Baltimore, 1920, xxiii, 691-744.

¹ L. S. Dudgeon, *Journ. Hyg.*, Cambridge, 1920, xix, 208-244

resembling blackwater fever. As long ago as 1909 Cleland suggested that blackwater fever was the evidence of anaphylaxis to the dead protein of the malarial parasite, and since then this idea has attracted some attention; but from a comparison of the morbid changes in blackwater fever with those in two fatal cases of anaphylaxis. Professor Dudgeon concludes that the only phenomenon common to both is the haemorrhagic state, which, of course, may be due to various causes.

INFECTIOUS MONONUCLEOSIS.

WRITING from the division of clinical pathology of the medical clinic in the Johns Hopkins University and Hospital, T. P. Sprunt and F. A. Evans¹ describe, under the somewhat laboratory title of mononuclear leucocytosis in relation to acute infections ("infectious mononucleosis"), a fairly clear-cut clinical group of cases, whether or not they may eventually prove to be all due to the same cause. These cases are of interest inasmuch as they may be regarded as acute leukaemia or lymphadenoma, and, though the authors do not refer to this point, have very probably been described under the name of glandular fever. Six cases, all in young adults, are reported; all had enlarged and tender cervical glands and five of the six had in addition a similar condition in the axillae and groins; the spleen was palpably enlarged in four. The average duration of fever was between two and three weeks, and was accompanied by moderately severe prostration. One patient had albumin and casts in the urine. In four of the cases there was tonsillitis or pharyngitis. The total leucocyte count was normal at first, but later there was a leucocytosis of 13,000 to 20,000 per cubic millimetre; the differential count showed a slight increase in the cells of the large mononuclear transitional group and the presence of many pathological lymphoid forms; later again there was a leucocytosis largely due to lymphoid cells, many of which were pathological. In three cases kept under observation these blood changes were found to persist for some weeks after the signs and symptoms had disappeared and then to pass away. The red blood cells, haemoglobin determinations, and the platelets, did not show any alteration other than that of a mild secondary anaemia incident to an acute infection. The prognosis, as shown by these six cases, which all recovered, appears to be good, but it is interesting to note that "eminent haematologists have considered the possibility of a leukaemia of transient nature from which the patient recovers spontaneously." Sections of excised glands were not normal, the lymphocytes being increased in numbers, but no positive diagnosis was justified. Attempts to determine the infective agent were unsuccessful; the Wassermann reaction and blood cultures were negative, and animal inoculation of a gland in one case did not give any information. In 1913 R. C. Cabot drew attention to the occurrence in rare instances of a lymphocytosis in wound sepsis, boils, and streptococcal adenitis of tonsillar origin, which can be distinguished from lymphoid leukaemia by the recognition of an infective origin for the adenitis, the lesser degree of the infective lymphocytosis, and the course of the disease. Professor Arthur Hall in the same year recorded such "a case resembling acute lymphatic leukaemia ending in complete recovery," and similar examples have been reported by Lüdka, Marchand, Sanders, and by Türk, who considered these cases as a key to the etiology of acute leukaemia.

PROFESSOR EDWARD HILL OF DUBLIN.

AMONG the attractions of the study of medical history it is not impossible that there may lurk a gratifying feeling of self-congratulation on our superior or more fortunate conditions as compared with those of our professional forebears. Thus, in tracing the development of a school of medicine, or in recording the evolution of medical science,

¹T. P. Sprunt and F. A. Evans. *Bull. Johns Hopkins Hosp.*, Baltimore, 1920, xxxi, 410-417.

we can from our secure pinnacle graciously award praise to those who struggled with difficulties that no longer block our way. A century ago medical controversies were conducted with the same violence of language and imputation of motives as those in which politicians and writers habitually indulged. How far the change in manners is superficial and a phase of fashion and how much may be ascribed to a real change in human nature will be variously estimated by each one of us according to his experience and temperament. That medical polemics flourished in Dublin as well as elsewhere is shown by the interesting sketch of Dr. Edward Hill (1741-1830) drawn by the scholarly Registrar of the Royal College of Physicians of Ireland, Dr. T. Percy C. Kirkpatrick, and presented by him to the College on St. Luke's Day, 1920. Dr. Edward Hill was for forty-nine years Regius Professor in the University of Dublin, and held every office, including that of president on five different occasions, and finally, when in his seventy-ninth year, became Dun's librarian in the Royal College of Physicians of Ireland. He was an accomplished scholar, well acquainted with the Latin, Greek, French, and Italian classics, and possessed of considerable skill in architecture; but he did not leave any medical writings, and does not appear to have been very fond of hospital practice, which he described as "a dangerous and arduous duty." What he regarded as his life's work was a word-index of *Paradisus Lest*—containing references to every occurrence of even the words "the," "and," "as"—which never saw the light of day, and may well be remembered as a monument of misdirected energy. His views about the duties of a teacher were formal to a degree: provided that a student knew his Hippocrates, his Galen, and his Celsus, what need had he to study sick people? It is not surprising that the Regius Professor was firmly opposed to the new-fangled idea, put forward about 1811 by James Maccartney, Professor of Anatomy, that examinations held under the *Licent ad examinandum* should be conducted in English instead of in Latin. But the most striking feature of Hill's long professional and professorial life is the weary and acrimonious disputes in which he was constantly engaged, mainly with Perceval. This rather unscrupulous rival had studied in Edinburgh and on the Continent, and was deeply impressed with the importance of clinical instruction; but his chief object appears to have been selfish, for he desired to be in a position to pose as the founder of a great hospital in Dublin. In this he partially succeeded, for the west wing of the present Sir Patrick Dun's Hospital in Great Canal Street was opened in 1807, but Perceval's name is scarcely remembered in the institution for the foundation of which he sacrificed so much honour. Hill, who wrote "in a baneful hour the utility of clinical lectures was suggested," failed in his opposition, but his honour remained untarnished. The truth is that both the antagonists, while professing to work for the good of the school, also strove for their personal aims.

MEMORIAL TO THE LATE DR. A. J. CHALMERS.

THE late Dr. A. J. Chalmers—the well known authority on tropical diseases, and joint author with Dr. Castellani of *Tropical Medicine*—whose sudden death on his way home on leave in April last shocked the profession and his numerous friends, left a splendid collection of medical books mainly on tropical diseases, and including some almost priceless incunabula. The whole of these, with the exception of about sixty volumes, presented to the Royal College of Physicians of London, have been presented by Mrs. Chalmers to the Royal Society of Medicine, which has decided that the collection shall be kept together and be known as the "Chalmers Collection." Mrs. Chalmers, we are informed, has presented the society with the sum of £500 for the shelving and furnishing of a room in which the books will be kept as a memorial of her husband. It is hoped that the collection of books on tropical medicine

will be added to from time to time, and the room chosen for the Chalmers Library is well adapted for the purpose. This coincides with the reconstruction of the new Section of Tropical Medicine and Parasitology. The Section was formed in 1912, but was suspended during the war, and has only this session been formally constituted, and among the first nominated officers are Lieut.-Colonel Sir Leonard Rogers, I.M.S., as president, and as vice-presidents, Professor Leonard S. Dudgeon, Lieut.-General Sir John Goodwin, D.G., A.M.S., Vice Admiral Sir Robert Hill, D.G.M.S., R.N., and Professor G. H. F. Nuttall. The new Section is fortunate in being able to start with a library of its own—perhaps the finest collection of books on tropical medicine to be found anywhere.

THE ROYAL CHEST HOSPITAL.

A SPECIAL meeting of the governors of the Royal Chest Hospital, presided over by the Lord Mayor of London, will be held at the Mansion House on Monday next, at 3 p.m., to consider and, if thought fit, to approve the scheme for the amalgamation of the Royal Chest Hospital, City Road, with the Great Northern Central Hospital. The suggested scheme is for the provision by the Great Northern Central Hospital of a number of beds allocated to diseases of the heart and lungs at least equal to those given up by the Royal Chest Hospital; the present buildings in City Road are to remain as the Royal Chest Section of the Great Northern Central Hospital until such time as building becomes practicable, when a block in the reconstructed Great Northern Hospital is to be named "The Royal Chest Hospital Block," and the out-patient department of the Royal Chest Hospital will continue in the City Road as an outpost of the chest section of the Great Northern Central Hospital; proper provision is to be made for both lay staff and medical staff of the Royal Chest Hospital. The Minister of Health was invited to express his opinion on the arrangements for amalgamation, and had no modification to suggest, agreeing that it would be wiser to amalgamate now, while the Royal Chest Hospital was free of debt, since its council had come to the conclusion that it could no longer undertake the responsibility of raising funds.

THE ALEXANDER AND PARKES MEMORIAL PRIZES.

The Alexander Memorial Prize, consisting of £50 with a gold medal, is awarded every third year to the writer of the best essay on a subject dealing with military surgery, military medicine, or military hygiene. The competition is open to executive officers of the R.A.M.C. on full pay, with the exception of professors and assistant professors of the Royal Army Medical College. The subject for the next prize is "Trench foot: its pathology and treatment (medical and surgical), with the administrative measures for the reduction of its incidence." Essays must bear evidence of the personal observations and experience of the writers: they should be sent to the Secretary, Alexander Memorial Prize, at the Royal Army Medical College, Millbank, S.W.1, by December 31st, 1921; each essay must have a motto, and be accompanied with a sealed envelope bearing the same motto, and containing the name of the competitor. The Parkes Memorial Prize, consisting of seventy-five guineas in money, with a gold medal of the value of fifteen guineas, is awarded every third year to the writer of the best essay on a subject connected with hygiene. The competition is open to the medical officers of the Army, Navy, and Indian Services, of executive rank on full pay, with the exception of the professors and assistant professors of the Royal Naval Medical College, Greenwich, and of the Army Medical School during their term of office. The subject for the next prize is "The means of spread and method of control of bacillary dysentery in the field" (to be illustrated, so far as practicable, from the personal experience of the writer).

Essays should be sent to the Secretary, Parkes Memorial Fund, Royal Army Medical College, Millbank, by December 31st, 1921. The rule as to the use of mottoes applies to this prize also.

REGULATIONS UNDER THE DANGEROUS DRUGS ACT.

THE Home Secretary, under the Dangerous Drugs Act, 1920, has drafted regulations for controlling and restricting the possession, sale, and distribution of raw opium; and a further set of regulations for controlling the manufacture, sale, possession, and distribution of morphine, cocaine, ecgonine, and diamorphine (commonly known as heroin) and their respective salts, and medicinal opium, and preparations and substances containing not less than one-fifth per cent. of morphine or one-tenth per cent. of cocaine, ecgonine, or diamorphine. Generally speaking these drugs may be supplied only to persons specially authorized, except when lawfully dispensed from a prescription given by a qualified medical practitioner in accordance with specified conditions. Persons, including medical practitioners, who dispense such prescriptions, must keep separate books for records of all dealings in the four groups of drugs: (a) cocaine and ecgonine and substances containing them; (b) morphine and substances containing it; (c) diamorphine and substances containing it; (d) medicinal opium. Medical practitioners and registered dentists and veterinary surgeons, together with dispensers at public hospitals or institutions registered under the Pharmacy Act, 1868, may possess and supply these drugs, so far as is necessary for the practice of their profession or employment. We propose to refer to the draft regulations in more detail at a later date. They appear to be in line with the war-time restrictions, introduced under the Defence of the Realm Act, which were described in our issue of November 17th, 1917, at p. 657.

HOSPITAL INQUIRY COMMITTEE.

BEFORE the rejection of the Ministry of Health (Miscellaneous Provisions) Bill in the House of Lords on December 14th, 1920, it was urged upon the Minister of Health by members of both Houses that every effort ought to be made to sustain the voluntary hospital system. With this object in view Dr. Addison agreed to appoint a small independent committee to consider the financial position of voluntary hospitals throughout the country and to make recommendations thereon at an early date. No official announcement has yet been made regarding the membership of this Committee, but a statement has appeared this week, and it is understood to be well founded, that the chairman will be Viscount Cave, who was Home Secretary from 1916 to 1919. The intention is that the Committee shall consist of five, and it is probable that the members will include Sir Clarendon Hyde, who is associated with Lord Cowdray as a director in a number of his undertakings.

In the *London Gazette* of January 11th it was announced that the King has signified his intention of conferring the honour of knighthood upon Dr. Maurice Craig, C.B.E., and Dr. P. Horton-Smith Hartley, C.V.O. Sir Maurice Craig is physician for psychological medicine and lecturer in the same subject at Guy's Hospital, and consulting neurologist to the Ministry of Pensions. Sir Percival Horton-Smith Hartley is physician and joint lecturer in medicine at St. Bartholomew's Hospital, and senior physician to the Brompton Hospital for Consumption.

In England sanatorium benefit will cease on May 1st to be included among the benefits conferred on insured persons by Part I of the National Insurance Act, 1911; in Scotland this termination has already taken place, and as from January 1st, 1921, the Public Health Local Authorities have been required to make arrangements for the treatment of tuberculosis in insured persons.

India.

CALCUTTA SCHOOL OF TROPICAL MEDICINE.

It is rather more than ten years since Sir Leonard Rogers proposed that a fully staffed and properly equipped school of tropical medicine should be founded in Calcutta. The proposal was approved by the Government of India, and an endowment fund was opened in 1914. It received liberal support from Indian noblemen, from the tea, jute, and mining associations, from the Tata oil and iron companies, and from Sir David Yule, who endowed a European chair of research in biochemistry; when Sir Leonard Rogers left India early this year he had the satisfaction of knowing that the whole scheme was on the way to completion. An appeal has recently been issued for further contributions to complete the endowment and equipment. The Calcutta School of Tropical Medicine and Hygiene consists of the school proper with its laboratories, an institute of hygiene with its laboratories, under the same roof as the college, and the Carmichael Hospital for Tropical Diseases with 116 beds. It is not intended that the classes at the school should exceed about forty, and the lecture theatre has been designed to accommodate fifty. The school building has four stories, and the laboratories have been designed under the supervision of Sir Leonard Rogers for the special purposes they are intended to serve. On the second floor is a temperate laboratory built with double windows and insulated walls, so that its temperature will be constantly below 70 F.; this will allow protozoological research work requiring low temperatures to be carried out at all times of the year. The fourth floor contains a series of eight laboratories for research work, an animal room, a dark room, and micro-photographic apparatus.

The purpose of establishing the hygiene section is to combine in one building laboratories under the control of the Sanitary Commissioner of Bengal, to co-ordinate the public health laboratory work of the province, and to raise the standard of education and efficiency of Deputy Sanitary Commissioners by providing facilities for post-graduate teaching and research. Classes for the degree of bachelor of hygiene and the diploma of public health of Calcutta University will be held annually from October to June.

The Carmichael Hospital is to be conducted as part of the tropical school. The hospital, which is close to the school, will be administered by the director of the school, who will allot beds as required to the members of the staff. The number of beds is 116 (43 European and 73 Indian), and the staff, which consists of eight professors and seven research workers, is large enough to ensure the intensive study of selected cases and personal teaching. There is a clinical laboratory.

The appeal now made is for contributions towards the upkeep of this hospital, to increase the endowment for a whole-time chair in research work, to endow an Indian research scholarship, and for improved equipment. Contributions are also asked to enable the chair of entomology and helminthology to be divided; it is regarded as very desirable to have a chair of helminthology in a country such as India, where helminthic infestations are very common. The director of the school is also professor of tropical medicine. The other chairs are tropical pathology and bacteriology, pharmacology, serology and immunology, tropical hygiene, biochemistry, and protozoology. The school has also a research chemist and teacher of chemistry and physics, and the hospital a resident medical officer. The members of the professorial research staff will devote their whole time to teaching and research, and will be debarred from private or consultant practice, receiving a local allowance in lieu. In order to maintain the standard necessary for post-graduate teaching it is proposed that all professorial and assistant professorial appointments shall be made by the Government of India, so that there may be the freest possible scope for the selection of the best men available in India.

MEDICAL COLLEGES IN BENGAL.

The Governor of Bengal, Lord Ronaldshay, who presided at the annual prize distribution at the Calcutta Medical College on December 1st, 1920, said that the rapidly increasing demand for medical education in Bengal was a most striking fact. This year the number of applicants for admission

to the Calcutta Medical College was 947, largely exceeding the number of vacancies, which was 153. The Government was anxious to increase facilities throughout the Presidency. To add to the efficiency of the Calcutta College heavy expenditure had been incurred, including the acquisition of plots of land at a cost of 21½ lakhs; the expenditure on servants' quarters was over 5 lakhs. It was intended to make provision also for students' hostels. Since Lord Ronaldshay spoke it has been officially announced that to meet the demand for a greater number of qualified medical practitioners the sanctioned strength of students at the Calcutta Medical School has been raised to 500 and at the Dacca School to 400. A medical school, with accommodation for 200 students, will be opened at Baridwan, and the question of establishing medical schools in other centres is under consideration, as are also schemes for the establishment of hospitals for incurables and convalescents in Calcutta, and for a leper colony.

England and Wales.

WORK OF THE CENTRAL MIDWIVES BOARD.

IN the annual report on the work of the Central Midwives Board the number of midwives on the roll is given as 45,960, a net increase for the year of 1,794. Of these, the number (so far as can be ascertained) who actually practise as midwives is relatively small, being only 11,488, of whom 7,865, or 68.5 per cent., are trained, and 3,623, or 31.5 per cent., untrained. The number of candidates entering for the Board's examinations during the year was 2,391, as against 1,997 in the previous year, and of those who completed the examination 1,904 passed, the percentage of failure being 18.8. Of the 54 penal cases dealt with by the Board, 22 were those of women who had neglected to advise medical assistance in cases of ophthalmia neonatorum, this large percentage being due, no doubt, to more vigilant action on the part of some of the local supervising authorities. At a conference of the Board with the Ministry of Health and the Board of Education it was agreed:

1. That as far as the training of pupil midwives was concerned a maternity home could not safely be combined with an infectious diseases hospital unless the wards of each were entirely separate, and the staff, both medical and nursing, were unable to meet.

2. (a) That where a maternity home was combined with a general or Poor Law hospital, an isolation block or ward should be set apart, and one or more nurses told off to attend the cases as they arose, and that the nurses should attend such cases only. (b) That while working in the maternity wards no pupil should be employed in any other work.

3. That a maternity home should not be recognized for the purpose of training pupils until it was able to show (a) that it had an adequate staff and arrangements for training, and (b) that it had a suitable number of cases to train upon.

MATERNITY HOMES AND CHILDREN'S INSTITUTIONS.

A memorandum has been issued by the Ministry of Health asking for information to be furnished annually by the authorities of maternity homes and hospitals for each year ending December 31st. This information should include: the total number of cases admitted; average duration of stay; number of cases (a) delivered by midwives, (b) by doctors. (c) in which medical assistance was sought by midwives, with reasons; number of cases notified as puerperal sepsis, and the treatment thereof; number of cases in which temperature rose above 100.4 for twenty-four hours, and pulse rate in such cases; number of cases notified as ophthalmia neonatorum, with result of treatment; number of cases of "inflammation of the eyes, however slight"; number of infants not entirely breast-fed while in the institution, with reasons; number of maternal deaths, with causes; number of foetal deaths (stillborn or within ten days of birth), with causes thereof, and results of *post-mortem* examination if obtainable. Immediate information should be sent to the Ministry of every case of maternal mortality occurring in the institution or due to illness contracted there, and of every notified case of puerperal fever.

The Ministry of Health has issued also a memorandum asking for annual information, to be supplied for the year ending December 31st, by the authorities of institutions

receiving resident children under 5 years of age. The desired information includes number of cases admitted, average duration of stay, reasons for admission, number and condition of health of cases discharged, number of cases of infectious disease, number of deaths with causes thereof, and number of children discharged on account of illness. It is further desired that immediate information should be sent to the Ministry of all deaths from gastro-enteritis or epidemic diarrhoea, with a brief statement of the circumstances.

Ireland.

ROBERT CAMPBELL MEMORIAL.

THE following additional subscriptions have been received towards the memorial to commemorate the pioneer work done for surgery by the late Mr. Robert Campbell of Belfast. It is proposed to establish a prize for distinguished work in any branch of medical science done by a member of the medical profession in Ulster or a graduate of Queen's University, Belfast.

	£	s.	d.		£	s.	d.
Amount already acknowledged in the JOURNAL	715	14	0	S. Wilson McComb	5	5	0
S. J. W. Donald (Sutton-Ashfield)	2	2	0	W. MacDermott	1	1	0
J. E. MacLiaine	10	10	0	Dr. and Mrs. John Campbell	52	10	0
W. T. Maguire (Dublin)	2	2	0	H. T. Hardy Green	1	1	0
T. Walker (Wakefield)	1	1	0	Adam Fulton (Southport)	5	0	0
Miss J. Dickie	5	5	0	W. Calwell	10	10	0
Rowland Hill	2	2	0	Sir William Whitla	10	0	0
T. M. Tale (Downpatrick)	2	2	0	F. S. Kirk	10	10	0
John Thompson	5	5	0	W. M. Killen (second instalment)	5	5	0
Stafford Geddis	2	2	0	H. P. Malcolm	3	3	0
Adam Moss (West Kirby)	5	5	0				
John R. Davison	2	2	0	Total	£259	17	0

Correspondence.

THE VOLUNTARY PRINCIPLE AND THE BRADFORD BOGEY.

SIR.—Amidst all the turmoil and discussion about the future of the hospitals Bradford is always being brought forward, first of all as an example of the failure of the voluntary principle, and secondly, as an example of what will be done for the salvation of the sick poor when once our hospital requirements are put into the hands of our municipal authorities.

May I, once and for all, put it on record that nearly everything which has been said about Bradford up to the present time is "more or less untrue"? Certainly nothing is more untrue than the statement that no poor patient can obtain admission to the Royal Infirmary unless he pays a fee to a member of the honorary staff. Such a statement has been made, and has found its way to the Ministry of Health, and has apparently been accepted in good faith. What an acknowledgement for four years' strenuous and gratuitous war service on the part of the honorary staff!

From your report of the recent conference on hospital finance it appears that Dr. Peter Macdonald of York repeated the Bradford story which has been current for a long time past—a story which is just so much propaganda to promote a general socialistic hospital policy throughout the kingdom. Lest his remarks should be accepted as those of an authority because they have not been challenged, will you allow me to analyse them?

Dr. Macdonald stated in the first place that we have 361 beds for a population "which cannot be less than half a million." The last record of the Bradford population was something nearly approaching three hundred thousand. Without criticizing his estimate of the available hospital accommodation in the city, may I point out that within a circle of twenty miles radius there are something like a score of hospitals which unite in providing hospital treatment for this part of the West Riding?

As regards Bradford itself, Dr. Macdonald states that "the conditions are so intolerable" that a municipal hospital has been established. That statement is incorrect. What has happened is that the guardians have recently handed over the management of the Poor Law hospital to the Health Committee of the Bradford Corporation, and the Poor Law hospital has thereby become

a municipal hospital. In spite of the change of name it remains the same old obsolete group of buildings which the Local Government Board condemned as unfit for hospital purposes twenty years ago. Moreover, it has been admitted at a town council meeting that after allowing for all the accommodation earmarked for what may be called public health purposes there is nothing left for general surgery and medicine. Nevertheless, the socialistic and Labour party, prior to the recent municipal elections, made haste to announce that they had now acquired a hospital second to none in the country and equipped with every modern convenience for dealing with all surgical and medical cases. The voluntary institutions were "back numbers" and would be scrapped, and everything would be on the rates before long.

Now, Sir, I have spent twenty years in Bradford, and during that period I have treated at least ten thousand working-class patients in the Royal Infirmary. I know that I am regarded as a "tiresome person" who is difficult to satisfy. The Royal Infirmary is an old obsolete building nearly as bad as the municipal hospital, and it is no fault of mine that we have not already acquired a new building. Nevertheless, we treat three thousand patients a year, and our results compare most favourably with any of the neighbouring cities, not excepting our great neighbour Leeds. There has been a great outcry about waiting lists, and we have been treated to a pathetic picture of the sick poor, hoping against hope for a long-delayed relief. During the war there was great hardship. Which of us had not to endure it? To-day there is no waiting list at the Royal Infirmary beyond a few patients who have fixed a certain date for admission to suit their own convenience.

Dr. Macdonald, whom I remember in Bradford some twenty years ago, has been talking "through his hat." He suggests that the Royal Infirmary is bankrupt to the tune of £1,000 a month. As a medical man he has forgotten or never learnt the axiom of one of our greatest surgical teachers, "Never believe anything you hear and only half of what you see"! In 1914 the income and expenditure of the Royal Infirmary balanced. Since that date, during a period of seven years, we have incurred a debit of £22,000. In 1914 our annual subscriptions, apart from investments and donations, amounted to £6,000. The workpeople's fund realized £3,400 in addition. The annual subscription list for 1920 is not far short of £17,000. The workpeople's fund is something over £9,000. We have received a cheque for £10,000 from the National Relief Fund against our overdraft. We have paid for a site for a new infirmary worth £20,000 and have £35,000 in hand besides promises for another £20,000. In addition we have just received £23,000 for a new infirmary from the old war hospital account! Moreover we have wiped out the socialistic party on the town council!

I trust that before the conference meets again, Dr. Peter Macdonald will have pondered over these facts, and taken them to heart. I trust that I shall not be considered as an extreme enthusiast for the voluntary principle. I should welcome a change of the old system, but I will fight to the last a policy which involves the murder of the voluntary hospital, and puts everything on the rates. We want co-operation. A first class general infirmary and a municipal hospital to work with it is the ideal. The latter should be staffed by the younger men who are aspiring to establish themselves as the consultants of the city; as soon as they acquire an honorary appointment on the voluntary hospital they should relinquish the salaried appointments at the municipal hospital and "take silk." Such an arrangement would be a blessing to everyone concerned.—I am, etc.,

Bradford, Jan. 5th.

J. BASIL HALL.

VOLUNTARY HOSPITAL STAFFS.

SIR,—Why does the medical profession desire to do the staffing of hospitals without remuneration? Such is the question put by Dr. Rees to the medical profession in your last issue. As I have been interested in the subject for many years, may I offer a partial answer, though I am unable to answer it completely?

In 1839, when the question of provision of hospital accommodation for the working people was considered by the Poor Law Commissioners, the members of the staffs of the metropolitan medical schools attached to charity

hospitals came to the conclusion that, were the State to establish hospitals in addition to the "charity" hospitals then in existence, they, as teachers, would be deprived of clinical cases necessary for the instruction of their pupils—the pupils being indirectly their source of future income. To-day the reason is ostensibly perhaps no longer quite the same, but the staffs of charity hospitals—in name—will in all probability join together with an object identical with that of the doctors who opposed the Poor Law reform in Victorian years, but the purpose now, as then, is essentially to prevent change, and to retain existing privileges.

Many members of the staffs of hospitals, with and without medical schools attached, now receive payments for the services they render, and they do this under the cloak of the title of honorary officer. I would ask, as a corollary to Dr. Rees's question, is this a course that can be justified?—I am, etc.,

Cambridge, Jan. 10th.

JOSEPH GRIFFITHS, Colonel.

LINES OF ADVANCE IN THE SURGERY OF BREAST CANCER.

SIR.—There are one or two points in Mr. Handley's most interesting paper on lines of advance in the surgery of breast cancer which I think call for consideration.

The mode of advance of the disease has been fully described in previous communications by Mr. Handley, but in the present one he emphasizes the supraclavicular and intercostal routes.

The tables of recurrence furnished indicate the prevalence of the supraclavicular route, and this confirms my own observations, which led to careful examination in the supraclavicular area for evidence of enlarged glands, with, in many cases, negative results.

As recurrence followed in this area, and in some instances many years after the excision of the mamma, it was felt that had the supraclavicular glands been removed a greater approach to a cure would have been effected. With a view to determining the condition of the supraclavicular glands which yielded no clinical manifestations of involvement, I decided to select six cases of breast cancer in which the growth was slow, the skin involvement slight, and the axillary glands palpable. A further examination of the supraclavicular area was made while the patient was under an anaesthetic, but no enlargement of glands was made out. After the removal of the breast and the axillary glands the dissection was continued into the neck, and in order to obtain free access to the glands at the inner angle the clavicular portion of the sternomastoid muscle was divided. All the loose tissue and glands were carefully removed, and for the purpose of microscope examination the tissue on the outer half of the space was kept separate from that on the inner side. On the completion of the operation most of the structures in this space, including the scalenus anticus and the phrenic nerve, were exposed.

In all six cases the parts removed from this area were examined by myself and the pathologist, and we failed to determine in three cases by the naked eye whether the glands were involved. A microscopic examination, however, showed that in five cases the glands were the seat of carcinomatous invasion; in only one case were the glands free.

It seems to me that no operation on the breast can be regarded as complete until the state of the supraclavicular glands is determined. The proximity of these glands to the first and second intercostal spaces would to my mind suggest that the intercostal recurrence was an extension from them. In any case no one will doubt the force of the statement, "Cancer cells which have reached the supraclavicular glands have obtained a favourable strategic position for the extension of their attack in various directions."

Apparently Mr. Handley does not favour the extension of the primary operation to the supraclavicular area, and yet in an earlier part of his paper he states that "there can be no doubt that the right treatment of supraclavicular recurrence in its early stages is operative." He would wait until the glands were palpable, yet this delay might determine the involvement of the gland capsule and the infiltration of the surrounding tissue. In one of my cases referred to this had definitely taken place. The suggested alternative to operation, of the introduction of radium

into the supraclavicular area, would be difficult of attainment in the west of Scotland owing to the limited supply available. So far the extended operation has not proved a serious strain on the patient, and in the six cases I describe there has been no recurrence: it is, however, too soon to make any definite pronouncement on this point. Personally, I strongly favour removal of the glands in the supraclavicular area, even in cases where they are not clinically detectable.—I am, etc.,

Glasgow, Jan. 10th.

R. H. PARRY.

GASTRIC ULCER AND GASTRIC CANCER.

SIR.—Mr. Thurstan Holland's interesting paper in your issue of January 1st contains the following very important statement:

"The experiences of a large x-ray department are strongly opposed to the theory that it is usual for cancer of the stomach to be preceded by a simple ulcer."

It will be remembered that there appeared some years ago a series of papers professing to prove that a very high percentage—even 75 per cent. and upwards—of gastric cancers were preceded by definite clinical evidence of gastric ulcer. I pointed out at the time that this was contrary to all competent medical opinion, and that those who made such statements were dealing with such highly specialized material—chiefly gastric ulcer cases—as to make any such generalization impossible.

It is interesting to see that radiological experience is now supporting the clinical experience of observers who have to deal with all kinds of gastric cases. The error they oppose is a serious one, obscuring diagnosis and misdirecting treatment.—I am, etc.,

Exeter, Jan. 10th.

W. GORDON.

THE MINISTRY OF HEALTH AND THE PROFESSION.

SIR.—I have no wish to engage in a controversy with Dr. Fothergill, but he ought not to be allowed to misquote my letter and misrepresent its tenor without a reply. Dr. Fothergill is, of course, at liberty to summarize as much as he likes, if he does it fairly, but when he places his summary within quotation marks and gives it a separate paragraphing he does what is not legitimate. I did not write what he quotes me as having written.

His misrepresentation seems to me to be equally deliberate, for on re-reading my letter I find no ambiguity. There was no invitation to the profession to concern itself with "politics and its many underhand ways," nor to indulge in any "deliberate individual partisan action on behalf of the present Ministry of Health." I distinctly said that "the politicians concerned may be left to look after their own case." The danger to which I drew attention was an attempt "to undermine the position and machinery of the Ministry of Health itself, and to discredit those of our own profession who are attached to it," particularly with reference to the equality of status of the medical and lay sides of the Ministry. This has nothing to do with party politics, or with specific questions of policy at all.

The Association was largely responsible for the setting up of the Ministry of Health with its present position and machinery. We felt very strongly about it, and Dr. Fothergill gave it as large a measure of support as he ever gives to anything. Now, when an attempt, with whatever motive, is being made seriously to degrade the importance of the Ministry, to make its medical side wholly subordinate to its lay side, and to prevent the publication and proper consideration of reports on medical and health subjects of vital importance to us all, Dr. Fothergill implores us to watch unmoved the destruction of much of the work which by our united efforts we so recently accomplished. I, on the contrary, assume that the principles we enunciated were seriously held, and that we still desire a Ministry of Health as a first-class department of State, within which, and in relation to which, the medical profession shall hold a position of importance second to none. If this be so, we ought now once more to emphasize these principles and this position, and neither to fold our hands nor, with Dr. Fothergill, to jump thoughtlessly to the aid of those who wish to relegate professional influence to its previous subordination in a variety of departments.—I am, etc.,

Hornsey, N., Jan. 8th.

H. B. BRACKENBURY.

ADRENALIN IN RESUSCITATION.

SIR,—I have read the article on this subject by Dr. Cranston Walker, in your issue of January 8th, 1921, with much interest. I performed a number of experiments on this subject some twelve years ago and came to the conclusion that in adrenalin we had the most powerful agent yet discovered for resuscitating the apparently dead. I found that it was possible to revive cats that had been dead (from chloroform poisoning) as much as twenty minutes after all signs of life had ceased. In one experiment the heart was exposed and attempts at resuscitation were not begun for twenty minutes after the heart was seen to have stopped beating.

It was found that the most effectual method of using adrenalin was not by injecting into the heart, but by giving a saline infusion into the veins containing 1 in 50,000 adrenalin. This was almost invariably effective in restarting the circulation, and direct stimulation of the heart was not necessary, the heart being automatically stimulated by distension of the right auricle.

I believed it to be a most valuable method of restoring to life persons who have died suddenly from accident, but who have no vital injury, such as cases of electric shock, drowning, and chloroform poisoning. The difficulty of its application lies in the fact that the necessary person skilled in the use of adrenalin transfusion, and the necessary simple apparatus, are so seldom available when wanted.—I am, etc.,

J. P. LOCKHART-MUMMERY, F.R.C.S.

London, W., Jan. 10th.

A Disclaimer.

SIR,—I very much regret that my article "Adrenalin in Resuscitation" (printed in last week's issue, p. 46) has been quoted and misquoted in the lay press, in some cases under sensational headlines, and with free use of my name. My article was meant to be a brief and cautious note of some experiments and suggestions—a pendant to Mr. Welby Fisher's paper—possibly of interest to others working on the subject. Further publicity was never imagined, and is most regrettable. I take responsibility only for the article as printed in the BRITISH MEDICAL JOURNAL, and take no responsibility for any statement on the subject made in the lay press.—I am, etc.,

Birmingham, Jan. 11th.

CRANSTON WALKER.

GLANDULAR FEVER.

SIR,—In the *Times* of to-day's date its medical correspondent calls attention to a mysterious infection, characterized by swelling of the glands round the angle of the jaw. I think it is probable that these are instances of glandular fever, which was first described by Pfeiffer in 1889, and of which a very good account was published by Sir Dawson Williams in 1897.

Glandular fever especially attacks children, but adults are not immune. Its principal characteristic is a rapid enlargement of the cervical glands deep to the sternomastoid muscle, usually towards its anterior border and about the middle of its length. There may be a previous period of malaise of twelve to forty-eight hours. The enlargement is sufficient to form a marked prominence on the neck. It may be entirely painless. The axillary and inguinal glands may also be enlarged, though to a much less extent, and also other glands in the neck. The spleen becomes palpable about the fourth day in a considerable proportion of cases. The temperature is commonly 101° to 103°, but may be higher. Changes in the fauces are very slight, and tonsillitis is absent. After a few days the glands in the neck subside rapidly, and convalescence is established in the second week. There is no rash. Suppuration is very rare. Complications are rare, the most frequent being a "haemorrhagic nephritis," which is apparently transient. Anaemia may develop, and convalescence is often prolonged. The glands may be palpable, though not visible, for several months. The blood in the acute stages may show a leucocytosis of 12,000 to 15,000 per cubic millimetre with a lymphocytosis.

As to diagnosis, it is distinguished from mumps by the swelling being distinctly below the angle of the jaw and by the freedom of the parotid. It is distinguished from infections of the fauces by the absence of tonsillitis and

the slight degree of changes in the pharynx. The absence of anaemia in the acute stages will rule out the diagnosis of acute leukaemia.

Treatment in the acute stages is symptomatic, but care must be taken during convalescence. The onset is usually unilateral, and the opposite side may be affected subsequently, or occasionally a recurrence takes place on the same side. I saw a typical case from its onset in July, 1920, and since then I have seen two others in hospital practice, nephritis occurring in one instance.—I am, etc.,

London, W., Jan. 5th.

H. LETHEBY TIDY.

PREVENTION OF VENEREAL DISEASE.

SIR,—The opponents of immediate self-disinfection seem to object to my having recommended that all boys and girls should have access to the latest scientific knowledge of this subject.

In speaking of boys and girls, I naturally referred to those who had reached the age of puberty. I did so designedly, being mindful of the prevalence of venereal diseases among the adolescent portion of the population.—I am, your obedient servant,

London, S.W.1, Jan. 7th.

WILLOUGHBY DE BROKE.

SIR,—Having just read the letters on this matter by Mr. Wansey Bayly and Dr. Jane Hawthorne in your issue of January 1st, and, in consequence, having re-read the "Note" distributed by the Medical Women's Federation, which is the subject of the just criticism of these writers, I desire to add a few supplementary remarks.

Some weeks ago I received a copy of the "Note" in question from the Medical Women's Federation, of the existence of which body I was previously ignorant. This Note bore no further indication of its authorship. As one of the lecturers at the London School of Medicine for Women for a period of over twenty years, dating from the time before women were admitted to the *Medical Register*, I was led by perusal of this Note to the conclusion that it was merely a manifesto from an inconsiderable clique composed of members with far inferior intelligence to that possessed by the average classes to whom in past years I had the pleasure and privilege of lecturing. The authors of this document apparently lacked the courage to name the society against which they directed their farrago of erroneous and irresponsible statement. The whole of the "Note" contains nothing but expression of biased opinions with no evidential basis whatever, and of deliberate misrepresentation of the principle and practice advocated by the Society for the Prevention of Venereal Disease.

I wish to subjoin to the weighty criticisms by Mr. Bayly and Dr. Jane Hawthorne the statement that such instructions relating to the disinfection of women as were given by this society were not considered as an essential part of the method of prevention which the society advocated. They were, in fact, inserted, with certain restrictions, mainly on the somewhat insistent representations of many medical women. It is, of course, well known that really efficacious disinfection is far more difficult of achievement in the case of women than of men, whether the attempt be made by the women themselves or by others; and it is clear that successful disinfection of males must entail freedom from infection of females and their progeny.—I am, etc.,

London, W., Jan. 4th.

H. BRYAN DONKIN.

P.S.—Please allow me a short comment on one letter that appeared in your issue of January 8th, in reply to Mr. Bayly and Dr. J. Hawthorne. Dr. Otto May, while professing himself as "loath to intervene" in the discussion of this subject, intervenes without showing any cause. The statements he makes concerning "prevention" in the British army on the Rhine are unverified, contrary to those made by others who have inquired into the matter, and in all probability entirely erroneous. There is no available evidence whatever of the existence of any such army regulations or practice concerning immediate self-disinfection as are in harmony with what is advocated by the Society for the Prevention of Venereal Disease. If such regulations do exist they must be concealed with remarkable success

and carried out very inefficiently. The rest of Dr. May's letter consists of a repetition of mere opinions, expressed by him in very fallacious logic, to the effect that the Society's instructions sanction and incite to "immorality." What amount of weight can be attributed to any of Dr. May's opinions on this subject will become apparent when it is remembered that he was for some time secretary to the National Council for Combating Venereal Diseases, which has always opposed scientific prevention by medical means; that later he began to speak fervently in favour of medical prevention, and joined the Society he now so grossly misrepresents; and lastly, that he subsequently changed his mind again, resigned his membership of that Society, and went back to the "National Council."

January 9th.

H. B. D.

CLAUSE 7 OF THE CRIMINAL LAW AMENDMENT BILL.

SIR,—Since in Clause 7 of the Criminal Law Amendment Bill the suggestion has been made to penalize any person imparting venereal disease to another person, and to penalize solicitation on the part of a person suffering from venereal disease, I have been attempting to inquire into the history of cases coming for treatment to a clinic from this point of view. I have come to the conclusion that the difficulty in the way of obtaining evidence will make Clause 7 a possible source of profit to those wicked women who are ready to take any means to oust men, but I fear that it will be of little or no use to the women who are sinned against, even if it does not lead to the men who have wronged them actually incriminating them as the source of the disease. The difficulties it will bring to medical men and women are obvious. These should be ignored if the clause were likely to work justly, but the possibility of our being used to give evidence by order of the court, which evidence may tell against what we believe to be the truth, is a prospect we must seek to avoid.

May I give a few examples to illustrate how such a clause might be used to obtain blackmail or cause a miscarriage of justice?

1. A wife, married three months to a seaman, appeared with generalized syphilis in a communicable form. If this woman brought an action against her husband, the evidence of the medical officer who examined the wife would be against the husband. Even if he could bring medical evidence to show he had no sign of syphilis, he would not have cleared himself, for he might have had a lesion and no sign be left. This woman admitted that she had been infected before marriage, and thought herself cured after a few injections. If she chose to say nothing of this, could she not use Clause 7 to levy blackmail on her husband?

2. A wife with generalized syphilis in a communicable form gave a history that signs had previously appeared in her husband. Again, might not the medical officer under Clause 7 be compelled to give evidence for the wife, though he or she might believe the wife guilty? This wife volunteered the information that she had exposed herself to infection from a man she had never seen before nor since, "because the money would be handy over the week end," that she had exposed her husband to infection the same evening, and that he had developed the disease first. If she had not volunteered this statement, would she not have had a good chance under Clause 7 of incriminating her husband?

3. A wife with generalized syphilis in a communicable form demanded a certificate to prove she was free from venereal disease because her husband threatened to divorce her unless she obtained such a certificate. In this case the medical officer could be obliged by the court to give evidence which would incriminate the wife; yet I believe that woman sinned against by the husband, who subsequently deserted her.

Before this clause becomes embodied in an Act of Parliament, can the British Medical Association do anything to so modify its wording that vexatious litigation and possible miscarriage of justice may be prevented? So far as the introduction of the word "knowingly" goes, I am afraid it will not do more than deter wicked men and women from getting treated at clinics, whence evidence of their knowledge may be forthcoming. Will it prevent them from going to medical men privately, and using them as pawns to play their game?

If the clause cannot be so worded as to make it impossible for it to be used to work more harm than good, cannot the British Medical Association do something to get it omitted from the Act?—I am, etc.,

Cardiff, Jan. 2nd.

ERIE EVANS, M.B.

THE RISKS AFTER OPERATIONS FOR TONSILS AND ADENOIDS IN OUTDOOR CLINICS.

SIR.—That the operation for the removal of tonsils and adenoids is often far from satisfactory, sometimes fatal, not infrequently complicated with severe septic affections, and that it far too often fails to remove the symptoms for which it was done, even when repeated more than once, can hardly be put down merely to negligence of the hospital authorities in providing suitable accommodation, since it is well known that such unfortunate occurrences are to be noted even when every precaution is taken at the time and for the period of convalescence.

The troubles would appear to arise largely from the lack of preparation and of education of the patient beforehand. In other conditions where operation is found to be necessary surgical cleanliness is universally aimed at. Surely this scientific principle should be applied to the throat and nose.

In many cases when the patient is already on the table, the nasal cavities themselves as well as the nasopharynx are found to be packed with mucopurulent discharges, and in advanced cases of nasal stasis one is apt to find that the child has never learnt the elementary hygienic practice of clearing its upper air passages by blowing the nose fully and correctly. In such cases the teaching of this, the only method of dealing safely with one of the most destructive of the waste products, is a work of skill and of patience.

The teeth, too, are often in a neglected state, and the fact that the mouth and the nose are both parts of the same cavity is overlooked. Mouth-breathing, too, has been the habit for so long that soft foods have taken a chief place in the diet. The teeth then have become loose and the gums septic.

Before one can reasonably hope to be more or less safe and avoid the complications to which Sir William Milligan calls attention in his letter of December 20th, 1920, these details should have the attention necessary, as they do elsewhere.

The nose appears to be an efficient filter of most of the air-borne germs—if not of all—but it can only do its work if it is kept in a healthy condition, free from all contaminating collections. Good habits must be instilled into the child in its early days. Were the domestic animals to store their waste products of respiration till these reached an advanced state of putrefaction, by drawing them back into their heads as children are so often allowed to do when they sniff, they would become unbearable and a great source of danger to themselves, their kind, and their owners.—I am, etc.,

OCTAVIA LEWIN,

Rhinologist to the Roll of Honour Hospital, Paddington, and to the London County Council.

London, W., Dec. 28th, 1920.

SIR,—All those who have anything to do with these cases must welcome the discussion now taking place. I have always looked upon the way in which they were treated in hospital after operation as almost a scandal; there is no need to emphasize the risks involved, but I do think it is important that the profession should speak plainly.

More than twenty years ago I remember asking a friend who had operated on a patient of mine in a nursing home why, when he kept the child in for five days after operation, he sent his hospital patients home in as many minutes: his reply was almost in the words that I see used by one of your correspondents: "It is a highly unsatisfactory, but, under existing circumstances, necessary procedure." "To expect hospital authorities to provide the accommodation for the ideal treatment of these very numerous cases is, I think, unreasonable."

It is because we have been saying this to ourselves for twenty years that so little has been done to improve matters; the public will do nothing so long as we allow things to remain as they are, and this applies not only to the particular case now being discussed, but to the whole question of hospital accommodation. We are responsible for the education of the public as to the need of making provision for those large classes of cases which require, but at present do not receive, institutional treatment—such, for instance, as the numerous medical cases which have not in the past been generally considered as hospital cases, maternity cases and others that it is not necessary here to

detail. Although the present moment is inopportune for the actual provision of these beds, there is no need for us to delay our campaign of education; we must make it generally realized that these things are essential for the public welfare, and we should now be making our plans ready to put them into operation as soon as opportunity occurs.—I am, etc.,

Bradford-on-Avon, Jan. 3rd.

CHAS. E. S. FLEMING.

EPILEPSY CONSIDERED AS A SYMPTOM.

SIR,—In his article on this subject in your issue of January 1st, Dr. Taylor, correctly, as I think, insists that epileptic convulsions may occur as a syndrome in various morbid conditions and that there is no disease entity to which the term epilepsy can be applied. He rightly urges that "each case of recurring convulsion must be studied by itself," yet he states that he has been "not a little disappointed and surprised at the tendency which has lately become obvious towards an attempt to approach its explanation on other grounds than that of physical disturbance." If epileptiform seizures may occur as a symptom in a variety of morbid states, as Dr. Taylor is at pains to show is the case, why should he be either disappointed or surprised when investigators of the symptom approach the subject open-mindedly and are prepared to take into consideration, not only physical, but psychological disturbances as of etiological significance? The very fact that "there is no such thing as a case of ordinary epilepsy" should deter anyone from undertaking observations on this symptom with a preconceived limiting hypothesis in mind. Many eminent authorities have investigated the subject of epilepsy from various points of view, and have profitably extended their studies to include also the interparoxysmal period. Indeed, it is chiefly to those who have refused to confine their attention wholly to physical disturbances that we owe the conception of epilepsy as a syndrome, not as a disease. I am not presumptuous enough to take up the defence of those who have disappointed and surprised Dr. Taylor, but I should like briefly to give the histories of two cases which came under my care last year, in order to show that psychic factors may in some instances be responsible for the symptom of epilepsy. Dr. Taylor wisely says that a study of Jacksonian attacks is likely to be illuminating, and my first case is of this nature.

He was a young man aged 22, of good family and personal history. He had served as a naval gunner on a merchant ship during the war. On the first night after his demobilization he had an epileptiform seizure, and continued to have them almost every night until he came under treatment in June, 1920. In the daytime he had typical Jacksonian fits beginning with movements in the fingers which spread up the right arm. The arm was gradually brought up in an extended pose to the level of the shoulder, with the index finger pointing, but the hand otherwise tightly closed. These attacks could be aborted if the arm were tightly seized and rubbed; but if this were not done unconsciousness and generalized convulsions often ensued. The Jacksonian fits invariably occurred in the afternoon, between 3 and 5 o'clock, and at the time he came to me he was having three or four every afternoon.

After taking a careful history I put the patient under light hypnosis, when he revealed the following repressed experience. One afternoon, while he was acting as gunner on a ship in a convoy off the north coast of Ireland, a hostile submarine had emerged at a range of only 500 yards. He pointed her out excitedly to his mates, giving the range. They opened fire, but were over their mark, and the U boat submerged but only to reappear at a greater range. Again they fired, but unsuccessfully, and again the U boat submerged. It was not seen again, but the watch was doubled, and the patient ordered to his bunk immediately, as he would have to take two consecutive watches of four hours each (actually from 12 midnight to 8 a.m.). His state of nervous tension and apprehension under these conditions may well be imagined. This memory, recalled under hypnosis, was then restored to his general consciousness, and he has never since that day had a Jacksonian fit.

He is also free from epileptiform seizures at night, though for a time, after any unusual excitement in the day, he used to toss about in his sleep, call out "We will give it them," and occasionally fell out of bed. As space is

limited I will make no further comment on this case, which seems to me to tell its own tale. No drugs or any other form of treatment were employed.

Dr. Taylor mentions the so-called "nocturnal epilepsy," and suggests that the condition of sleep rather than the time of day determines the onset of the convulsions. The following case supports this conclusion, though it does not favour his further presumption that some condition of nutrition or circulation is the cause of the convulsions.

A young man, aged 23, enlisted at the end of 1914, and was sent to work on munitions until March, 1917, when he was called up for training. In August, 1917, he was being transported to France (Le Havre); the voyage was rough and prolonged on account of reported menace from submarines. The man felt very sick and exhausted. In this state he lay down and tried to go to sleep. He then began to twitch all over and went off into an epileptiform convulsion. On arrival at Le Havre he was so helpless that he had to be carried off the boat to hospital. He was discharged from hospital in a week, and after a short stay at a convalescent camp was sent up to join his battery at the front. After a few days the battery was subjected to a heavy bombardment. The man was at the commencement of this in a dug-out by himself, but he rushed out and entered another dug-out which contained two other men. There he had another epileptic seizure. He was evacuated to the base and then to the United Kingdom. At Brighton he had frequent seizures which lasted about twenty minutes and always occurred at night, except on one occasion when he went to sleep in the afternoon and then had a convulsion. Eventually he was seen in a "fit" by the medical officer, certified as epilepsy and discharged from the service.

At the time he was sent to me he was having seizures about once a fortnight. They always occurred at night, generally when he was in a twilight or half-asleep state. Often before the convulsion came on he would partially wake up and lie for some time in a dreamy condition; then an aura as of the smell of a boat would precede the onset of a convulsion. Next day he felt dizzy, dull, and lethargic. Psychological analysis was undertaken, and the patient came to realize the meaning of his attacks and the repressed fear which underlay their initiation. Since this he has only had two convulsions, both following certain excitations which were analysed and showed a direct stimulation of the original complex. In my opinion these two cases serve conclusively to show that amongst the many causes of the epileptic syndrome psychological ones have a place.

It is far from my intention to argue that psychological factors only produce the syndrome, but I equally deprecate any attempt to attribute it exclusively to physical disturbances, whether these be an undefined cortical irritation, nutritional or circulatory changes, or endocrine dysfunction. In agreeing to consider epilepsy as a syndrome and not as a disease let us also agree to be entirely unbiassed in our search after its many possible etiological determinants.—I am, etc.,

Birmingham, Jan. 8th.

ALFRED CARVER.

ANGIO-NEUROTIC OEDEMA.

SIR,—I was much interested in Dr. Swan's letter upon this subject in the *JOURNAL* of January 8th. I fear, however, that he may be disappointed as to the curative value of horse serum. Some years ago I had a conversation with Sir William Gowers, who remarked that there were probably palliatives, but probably no cure, as he considered this condition to be an expression of the "gouty diathesis." I have been fortunate in seeing my share of these cases, and, while not quite in accord with Sir William as to the origin he thought invariable, I must confess I have never yet seen a case in which recurrence, sometimes long delayed, has not taken place. I gave some of my experiences of this disorder in a memorandum to the *Lancet*, June 2nd, 1906, and to your *JOURNAL*, May 22nd, 1915, and will now, but repeat that it appears to me to have its place amongst the paroxysmal neuroses. Whether or not it is (oppositely) related to epilepsy is an interesting theory. Perhaps Dr. Davis, who recorded a case in the *JOURNAL* of April 3rd, 1915, may have further remarks to make.—I am, etc.,

Exeter, Jan. 9th.

CLAUDE A. P. TRUMAN.

THE BEGINNINGS OF LIFE.

SIR,—Your interesting article suggests that biology is played out and that chemistry can tell us all about it. It appears that the chemists have proved that "fresh-water and marine algae" get their N from the air. There is nothing new about this (Green, *Vegetable Physiology*, 1900, p. 179). Most of the N-fixing algae turned out to have the N fixed by symbiotic bacteria. Still in regard to some the evidence was suggestive. Probably Professor Moore and his associates have definitely settled the matter for certain species, but this would scarcely justify generalization. Your last sentence, however (probably quoted from the chemists), proclaims the general misapprehension of the terms bacteria, fungi, and algae.

In amoeba there is a nucleus, cytoplasm, contractile vesicle, etc. It is a lowly organism compared with "marine and fresh-water algae," but it is by no means primitive. Bacteria are much nearer to primitive plants because no nucleus is demonstrable in the largest, and simple cellular division is the only mode of increase. Some have acquired a cell wall which enables them to form spores, but absence of nucleus imposes a limit of one spore to one bacillus. In the absence of photosynthesis nutrition may be difficult, but there still survive nitrifying bacteria which form combined C without chlorophyll (Bower, *Botany of the Living Plant*, p. 105). Even these have solved the N and C riddle, yet Moore and Webster think it more promising to study such "marine and fresh-water algae" as could exist in the "primordial world."

Out of their legions of algae let us take the most primitive, the unicellular blue-green. In a few the mode of increase is almost as primitive as in the bacteria, yet the lowest has a cell wall and colouring matters which include chlorophyll. For a tiny protoplast the synthesis of chlorophyll was a mighty achievement, and marked the beginning of a new epoch. But the spark of life flickered fitfully for ages before this, and it is possible that bacteria are the sole survivors of the pre-chlorophyllous age.

In order to compare them with bacteria the blue-green algae are often called Schizophytes, which is pernicious nonsense. It is certain that 70 per cent. of known forms increase by homogones and spores and not by fission, and that some branch habitually. Besides, there is always a demonstrable incipient nucleus the existence of which is rendered possible by food reserves accumulated by the chlorophyll. Cellular division is always amitotic. Nevertheless, the nucleus remains an open and imperfect one, and this accounts for complete absence of sexuality (West, *Algae*, 1916, p. 39).

In the case of Dodder we may speak of degradation, because in its flowers and in its tissues we have evidence of its origin and of its fall. But what evidence is there that bacteria are degraded algae? Every other division of plants has contributed to the saprophytes—why not the lowest, the bacteria? Contrary to what obtains in the bacteria, in the fungi there is evidence that they are derived from algae.

It has been pointed out that the achievements of the blue-green algae were the synthesis of chlorophyll and the differentiation of part of the cytoplasm as a nucleus, and that they were only partially successful with the nucleus and failed to reach sexuality. Consequently their line of development leads into a blind alley, and they helped evolution mainly by contributing organic material for the needs of others. One must go back to the common stock (now enriched with this material) to find a starting point for higher forms. From a crowd of simple forms botanists are agreed that a type emerged which is fairly represented by *Euglena*. Unicellular, sometimes with and sometimes without chlorophyll, but always possessing a stable nucleus, it is motile for part of its life, but encysted in times of stress. And the latter stage became more or less fixed—a plant—in such forms as *Protococcus*, *Chlamydomonas*. The nucleus was soon perfected, mitosis established, and sex developed with an increasing complexity of structure in the plants which issued in the green, the brown, and the red algae to colonize successfully the waters of the world.

For our purpose it is sufficient to direct attention to one branch of the green algae which terminated in *Vaucheria*. Mr. Masee remarked (*Textbook of Fungi*, 1910, p. 183):

"The Phycomyces are most nearly in touch with the algae; there is the same structure save in the absence of chlorophyll;

this last feature in reality constitutes the only difference between many and such algae as *Vaucheria*." And he added (p. 185): "the Oomycetes, the most primitive fungi, . . . would come from *Vaucheria*," and he explains (p. 21) that in these lowly fungi "reduction in number of the chromosomes, from eight to four, takes place in the gametogenesis."

It will now be understood how far astray are those who link up bacteria with organisms so elaborate as even the lowest fungi. The only possible view is that the fungi are certain higher algae which have become saprophytic and achlorophyllous. Now we can understand that Moore and Webster prefer to work, not with the complex and atypical, but with the simple algae.

Such a dissertation is provoked by the fact that in recent years medical writers have been spinning yarns about the fungi. Just before the war the magazines told us how bacteria and yeasts arise *de novo* in test tubes. The nucleus of a toad is more complex than that of the blue-green algae, and bacteria have no nucleus at all, yet we were assured that the first as well as the last arise indiscriminately as the result of a cross between a sunbeam and a salt solution. In a popular book Professor B. Moore has almost acquiesced in this, in spite of the absence of marine and fresh-water algae. In your own column recently a writer described a method of culture by which a meningococcus was transformed into a meningococcus of which he gave photographs. The gulf that separates the meningococcus from the ascomycetes cannot be bridged by horticulture.—I am, etc.,

ROBERT CRAIK, M.D. Glasg.

West Ealing, W., Dec. 29th, 1920.

ARTIFICIAL LEGS.

SIR,—I have been much interested in reading the article on artificial limbs in your issue of December 18th, 1920. The very equitable way in which you have reviewed the situation leads me to believe that some of my own experience may be of help in the very vexed question of light limbs.

In an experience of many years, not only in my own practice, but in that of my fellow artificial limb-makers, the question of lightness has ever been present, and I venture to say that at the present time limbs for above-knee amputation made of wood can be produced as light as their prototypes in duralumin.

No lighter limb exists than the British Anglesey type, which is practically constructed in wood (willow), only a small portion of the knee and ankle bolt being of metal. Numbers of these have been many years in wear, and the various British artificial limb-makers can testify to the ease with which their patients have used, and are still using and wearing, these limbs.

In your article you state that "the only type of limb which approaches in weight to 9 lb. is that made for exarticulation at the hip." It is quite true that the type of limb for this amputation is one where the reduction of weight is of the greatest importance. Recently I have turned my attention to the construction of these limbs with duralumin lower portions, that is to say, the limb from the tilting table downwards is constructed in duralumin alone. It is a fact that where two limbs are made of equal weight—namely, one of leather tilting table and willow lower portion, the other with leather tilting table and duralumin lower portion—the duralumin limb will invariably be pronounced by the patient to be the lighter of the two, from the fact that the centre of gravity has been brought nearer to the body, and the dead weight of the lower limb has been enormously decreased.

By the above remark it would be inferred that both limbs, either made of willow or duralumin, weigh the same. In my earliest experience I found this to be the result owing to the amount of strengthening by steel required in the duralumin lower portion; but experiments have been made and the experience gained enables me to produce an artificial limb for through hip amputation with duralumin lower portion weighing seven pounds. This reduction in weight is a very considerable item.

Further, in your article you say that for amputation below the knee "no light metal limb has yet been put forward which has any advantage in weight or otherwise over wood, leather, and steel." For some considerable time past I have designed and made a light duralumin limb for below-knee amputation which has been an

unqualified success in every way. A number of these limbs are now in use both for officers and for many of my private cases who had already been fitted with leather and wooden limbs, and each patient has expressed the greatest relief from weight and a more ready use of the limb when the duralumin limb is applied. These limbs are in use by many who are able to dance perfectly, ride, shoot over the roughest ground, play tennis, golf, and follow the life they led previous to their disability; amongst lady patients, several of whom are delicate, the change from the old limb to the duralumin limb has been of the greatest benefit.

In the concluding paragraph of your article you state that "the Ministry of Pensions may have experienced insuperable difficulty in an attempt to persuade the Treasury to approve the expenditure of nearly £100 for each of a large number of limbs." This sum is quite fantastic, and approximately half this amount is now sufficient to provide a perfectly constructed duralumin limb for practically any amputation.—I am, etc..

F. G. ERNST.

Branch of Associated Surgical Appliance Makers, Ltd.,
Charlotte Street, London, W., Jan. 5th.

FAT-SOLUBLE "A" CONTENT OF OILS.

SIR,—I regret to find on reading through Professor Halliburton's reply to my letter published in your issue of December 11th, 1920, that the purpose of that communication is liable to be misunderstood. As a result of my own difficulties in consulting the literature dealing with this subject, I wished to call attention to the necessity for greater precision in the description of samples of oils and fats used for experimental feeding. Edible oils and fats of commercial quality are prepared by a variety of processes differing greatly in their possible effect on the original vitamin content; and the statement, for example, that coconut oil is deficient in fat-soluble "A," is of very little value either to the physiological worker or to the manufacturer. The objection raised by Professor Halliburton as to the difficulty of tracing the history of samples available for investigation is one which, I feel sure, is not insurmountable.

I would also take this opportunity of pointing out that I did not say that the Medical Research Council's report was worthless, but that certain results contained in it, examples of which I quoted, were, for the reason I have given above, practically worthless.—I am, etc..

Port Sunlight, Cheshire, Jan. 4th.

A. D. STAMMERS.

Medico-Legal.

THE DEFINITION OF INSANITY.

IN a case recently heard at the Central Criminal Court Sir Robert Armstrong-Jones, who had been called on the part of a prisoner charged with murder, expressed the opinion that the accused was insane when the crime was committed. Having answered certain questions with regard to suicide, the witness also stated that he did not agree with the rule laid down in Macnaghten's case. Referring to this in the course of his summing up, Mr. Justice Darling said: "That rule is binding on us. We take the law of England from the King's Bench and not from Harley Street; from the House of Lords and not from Wimpole Street or any other street." It is curious to notice that this is the only passage in the summing up which one leading daily newspaper thought it necessary to report.

In the event the jury found the prisoner guilty but insane, and he was ordered to be detained until His Majesty's pleasure be known. The learned judge's observation was hardly courteous to the witness, and, if intended to be jocular, it was ill-timed, seeing that the prisoner was on trial for his life; but there is no doubt that it is the legal, not the medical, view of insanity which will prevail in courts of justice.

In 1843 His Majesty's judges were summoned to advise the House of Lords in the case of one Macnaghten, who was charged with murder. Insanity had been pleaded as a defence. The opinion which the judges expressed has been adopted ever since. The material words are:

"The jury ought to be told in all cases that every man is presumed to be sane, and to possess a sufficient degree of reason to be responsible for his crimes, until the contrary be proved to their satisfaction; and that to establish a defence on the ground

of insanity, it must be clearly proved that at the time of committing the act the accused was labouring under such a defect of reason, from disease of the mind, as not to know the nature and quality of the act he was doing, or, if he did know it, that he did not know what he was doing was wrong."

Sir Robert Armstrong-Jones is not the first member of the medical profession to dissent from this opinion. In the latest edition of *Taylor's Medical Jurisprudence* the late Dr. F. J. Smith pointed out that in 1894 a committee of members was instructed by the Medico-Psychological Association to report on the subject. They did so in 1896. They concluded their report by saying that:

"While not approving the doctrines and definitions contained in the judge's answers to the House of Lords in 1843, we are at present unable to make any recommendations for the amendment of the law."

One of the points in dispute between the lawyers and the medical profession is the meaning which should be attached to the word "wrong" which occurs in the definition. The lawyer has his own conception of the word; and as it is his task to explain matters to the jury the result of a trial where insanity is pleaded is often curious. Nor are the lawyers themselves altogether satisfied with the definition.

In his presidential address to the Medico-Legal Society (printed in the *JOURNAL* of November 13th, 1920) Lord Justice Atkin referred to the matter. He expressed the opinion that there ought to be some change in the formula laid down in Macnaghten's case, but he went on to point out that,

"after all, order has to be maintained, and it is no use criticizing the formula in Macnaghten's case unless you can substitute some effective formula in its place which will not have the effect of removing all criminals from a gaol to an asylum."

Not only does the rule in Macnaghten's case hold the field, but, as was pointed out in a leading article published in this *JOURNAL* in 1914¹ when commenting on the case of *Rex v. Felstead*, a man who is found "guilty but insane" has no right of appeal from that part of the verdict which finds him insane, although it had been decided in a previous case (*Rex v. McHardy*) that he may appeal from that part of the verdict which finds him guilty! It follows that under the present law a man may be detained at Broadmoor for the rest of his natural life if the jury, under the direction of the judge, find that he was not responsible for his actions. Everything depends upon the view of Macnaghten's case which a particular judge lays before the jury. One learned judge is said to have boiled the matter down to a single sentence: "Could he help it?" Such a definition is much too vague—especially in a court of criminal jurisdiction.

As Lord Justice Duke intimated in the course of a speech which he delivered at the recent dinner of the Medico-Legal Society: "There should be no doubt upon a rule affecting matters of life and death." It ought not to be difficult for lawyers and doctors to put their heads together in order to arrive at a definition satisfactory to both; but in the meantime it is well to remember that in the vast majority of cases where insanity is pleaded in courts of law, medical testimony is decisive, and that is commonly the evidence of a single witness. For example, there are scores of cases in which the prisoner, on his arraignment, either refuses to plead or answers in such a way as to render it doubtful whether he understands the meaning of the question, "Are you guilty or not guilty?" The jury are then sworn to try whether he is or is not fit to plead, whereupon the prison doctor is called to speak as to his mental condition, and his evidence is absolutely conclusive.

It may be remembered that in 1914 there was appointed a Crime and Punishment Subcommittee of the Medico-Political Committee of the British Medical Association, which co-opted representatives of the Medico-Legal Society, the Medico-Psychological Association, the Bar Council, and the Law Society. This Committee considered at length the state of the law with regard to the legal responsibility for crime, with special reference to the opinions of the judges delivered at the request of the House of Lords after the trial of Macnaghten in 1843, and reported with recommendations to the Council of the Association, so that the suggestion of Lord Justice Duke has already been acted upon by the British Medical Association. In his *Digest of Criminal Law* (Article 27) Sir James Fitzjames Stephen suggested the following modifications of the opinions of the judges:

No act is a crime if the person who does it is at the time when it is done prevented [either by defective mental power or] by any disease affecting his mind (a) from knowing the nature

¹ BRITISH MEDICAL JOURNAL, April 18th, 1914, p. 877.

and quality of his act, or (b) from knowing that the act is wrong (or (c) from controlling his own conduct unless the absence of the power of control has been produced by his own default.

But an act may be crime, although the mind of a person who does it is affected by disease, if such disease does not in fact produce upon his mind one or other of the effects above mentioned in reference to that act.

N.B. "Wrong" may mean (1) morally wrong, 2) illegal."

Ultimately the Subcommittee expressed the opinion that the following might be accepted by the medical profession as a fair definition of responsibility for crime in preference to the ruling laid down by Sir James Fitzjames Stephen:

No act is a crime if the person who does it is at the time when it is done prevented either by defective mental power or by any disease affecting his mind:

- (a) From knowing and appreciating the nature and quality of his act or the circumstances in which it is done; or
- (b) From knowing and appreciating that the act is wrong; or
- (c) From controlling his own conduct unless the absence of the power of control has been produced by his own default.

N.B. "Wrong" means morally wrong or illegal.

The Subcommittee, therefore, took the suggested modifications of Sir James Fitzjames Stephen as the foundation of its own report, and made a further modification as acceptable to medical opinion, after consultation with the legal members of the Committee. Sir James Fitzjames Stephen's last sentence might, perhaps, have been retained as more exact in its phraseology: the Subcommittee's form of words might imply that morally wrong and illegal were synonymous. The Subcommittee reported further that there was need for reform in other matters related to this question—for example, regarding the evidence before the Court as to the mental condition of accused persons; the position of persons found "guilty but insane" and the ruling laid down that such persons had no right of appeal; and the desirability that medical officers of prisons should have had experience in the diagnosis and treatment of insanity.

Obituary.

R. J. BLISS HOWARD, M.D., MCGILL, F.R.C.S. (ENG.).

We regret to have to announce the death, on January 9th, after a long and painful illness, of Dr. Robert J. Bliss Howard. He was born in Montreal in 1859, the son of Dr. Robert Palmer Howard, Professor of Medicine in McGill University, one of the three teachers Sir William Osler recalled as having had most influence on his mind in his early years. When the younger Howard began his studies at McGill University Osler was professor of medicine, and throughout his life he remained Howard's firm friend. Howard graduated B.A. with first class honours in natural science in 1879, and M.D., C.M., taking the gold medal, in 1882. After completing his career at Montreal, Howard attended the London Hospital, and in 1882 became M.R.C.S. and L.R.C.P.; two years later he became F.R.C.S. He studied also in Berlin, Vienna, and Leipzig. For some years he was associated with his father in practice in Montreal, and was also demonstrator of anatomy and surgery at McGill University, and pathologist and assistant surgeon to the Montreal General Hospital. In 1888 he married the only daughter of Sir Donald Smith—afterwards Lord Strathcona and Mount Royal. For a time he practised in London as a laryngologist, but after some years retired and devoted himself to country pursuits, especially shooting and fishing. During the war he organized the Mount Royal Hospital for Officers at Bath; he worked also at the 3rd London General Hospital, in which he took a great interest. He is survived by Lady Strathcona. They had a family of three sons, all of whom served in the war, and two daughters. His eldest son served throughout the whole of the war in France. His second son was killed in action, and the third son was severely wounded. Each of his daughters married naval officers—Commander Kitson and Lord Conington.

Dr. HERBERT SPENCER writes: The death of Dr. R. J. Bliss Howard will arouse feelings of profound sorrow in the hearts of those who knew him. He was a man of very considerable intellectual powers and had a distinguished academic career at McGill. His manner, sometimes flippant and bantering, occasionally misled those who did not know him to think him superficial; but those who knew him intimately, as I did for nearly thirty years, found him to be a sincere, true-hearted, unselfish, and loyal friend. He was keenly interested in shooting, fishing,

and natural history. The happy days spent sporting in his company at Glencoe and Debdon will be to many a very pleasant memory, and the patience with which he spent his last sad days an example of courage and resignation.

LAURENCE HERSCHELL HARRIS, M.B., CH.M.,
Sydney.

Dr. LAURENCE HERSCHELL LEVI HARRIS has died at his residence in Sydney after an illness extending over three months. He was born in Sydney in 1871, and educated at the Sydney Grammar School and afterwards at the Sydney University, where he graduated M.B., CH.M. in 1896. After graduation he became one of the resident medical officers at the Sydney Hospital, and subsequently was appointed medical superintendent. As he had always been keenly interested in photography he naturally took to x-ray work, a subject which at that time was being introduced all over the world. He was thus one of the pioneers in this branch of medical work, and was the recognized leader in it in Sydney. Like most workers with the x-rays he was attacked by dermatitis, and this led to the loss of one of his fingers as well as to constant trouble with his hands for many years. He was appointed honorary radiographer to the Sydney Hospital in 1900, a post he held for fifteen years; he was then appointed honorary consulting radiographer. He was subsequently appointed honorary radiographer to the Royal Prince Alfred Hospital, and at the time of his death he held this appointment, and a corresponding post at the Royal Alexandra Hospital for Children, at the Tubercular Dispensary, and at the Australian Jockey Club Home for Wounded Soldiers.

In 1914, while away on holiday, he was present at the British Medical Association meeting at Aberdeen, and on learning that war was imminent with Germany he volunteered his services as radiographer for any Australian unit which might be organized. He accepted the post of radiographer to the Australian Voluntary Hospital, and he organized his department so efficiently that on arrival at St. Nazaire on September 5th, 1914, seven hours after the equipment was landed at the hospital x-rays were available for the benefit of the wounded who were arriving from Mons. In the spring of 1915 he was ordered to join up with the No. 3 Australian General Hospital at Lemnos. The outfit which he had selected and taken out with him to Lemnos was subsequently pronounced by the late Sir Victor Horsley to be the best equipped x-ray outfit in the Mediterranean Expeditionary Force. Although hampered by ill health and under great disadvantages of climate and surroundings he continued to do excellent work until he was invalided to England, in consequence of the affection of his hands, just about the time of the evacuation of Gallipoli. He subsequently returned to Sydney and resumed his hospital and private work.

All through life his interest in nurses was manifested by many acts of kindness. All his military pay in the early months of the war was devoted to providing them with extra and much needed comforts. In his will he has left:

"To the treasurers of the Royal and Prince Alfred and Sydney Hospitals the sum of £4,000 to be held by them upon trust to apply the income in equal proportions, so far as may be considered necessary, in each year in rendering pecuniary assistance to nurses employed at these hospitals who, either during their course of training or while on the staff, shall be rendered temporarily incapable through illness or accident from continuing to discharge their duties, with a view to afford such nurses an opportunity for a change of air and scene, and thereby assist them in regaining health."

Harris was a man of most kindly disposition, ever willing to share his knowledge and experience with others, and was much liked and trusted by his fellow medical men, who were always ready to take his advice as to the treatment of any of their relatives. He was given a military funeral, which was attended by a large number of his fellow military officers and other medical men. The service at the graveside, in a Rookwood Cemetery, in the Jewish section, was conducted by Rabbi Cohen.

Dr. ALFRED WILSON EIMS, who died recently at Thurgarton, was born at Kingston-on-Thames in January, 1850. He was educated at the Ilminster Grammar School and Guy's Hospital, took the diplomas of M.R.C.S. and L.S.A. in 1872, and graduated M.D. (Duch.) in 1893. He

had practised at Belgrave, Leicester, for over forty years, and only removed to Thureaston in September last. At the end of 1919 he resigned his professional appointments, but still continued his private practice. He took great interest in local affairs, was a J.P. for Leicestershire, chairman of the trustees of the Belgrave Church Estate Charity, and a member of the Leicester and Rutland Division of the British Medical Association. Dr. Emma's is survived by his widow and a married daughter.

DR. ROBERT SLATER MAIR died in London on December 21st, 1920, aged 94. He was born at Paisley in 1826, was educated at the universities of Edinburgh and Glasgow, and took the M.D. at St. Andrews in 1850, and the F.R.C.S. Edin. in 1863. Soon after qualifying he went to India, and spent seventeen years in private practice at Madras, also holding the posts of deputy coroner of that city and medical officer of the local volunteer corps, the Madras Volunteer Guards. While in India he wrote two once popular works, *The European in India and Medical Guide to Anglo-Indians, 1873*, and *On the Management of Children in India, 1875*. On his return to England he set up in practice in Bayswater, and for forty years held the post of inspector of factories for the City of London, till he resigned some four years ago. He had also been physician to the Persian Embassy, and was a vice-president of the Harveian Society. While in Madras he married Miss Mary Anne Batchelor in 1862, and in 1912 celebrated his golden wedding. He had a family of five sons and three daughters, all of whom, except the eldest son, survive him. Two of his sons, Lieut. Colonel R. J. B. Mair, late R.E., and Colonel G. T. Mair, D.S.O., late R.A., received the C.M.G. for their services in the late war.

WE regret to record the death in tragic circumstances of DR. ALEXANDER WILLIAM MATHER, of Norton-on-Tees. Dr. Mather studied medicine at the University of Edinburgh, graduating M.B., Ch.B. in 1912, and proceeding M.D. in 1916. After acting as resident house-physician at the Royal Infirmary, Edinburgh, resident surgical officer at St. Mary's Hospital, Manchester, and senior house-surgeon at the North Riding Infirmary, Middlesborough, he settled in practice two years ago at Norton, where he was very popular. His death was the result of burns produced by an explosion in his garage while he was preparing his car for a professional visit. Dr. Mather leaves a widow and young child.

WALTER GIBSON MARSDEN, late Captain R.A.M.C. (T.C.), died in St. Thomas's Hospital on December 19th, 1920, after a long illness, contracted on active service. He was the eldest son of Walter Marsden, of Fairfield, Manchester, and was educated at St. Thomas's Hospital and at Cambridge, where he graduated as B.A. in the Natural Science Tripos in 1908 and as B.C. in 1911, also taking the M.R.C.S. and L.R.C.P. London in the latter year, after which he filled the posts successively of house-surgeon, casualty officer, resident anaesthetist, obstetric house-physician, and resident accoucheur at St. Thomas's. He took a temporary commission as lieutenant in the R.A.M.C. on April 26th, 1916, and was promoted to captain after a year's service. Before going abroad he served in the British Red Cross Hospital at Netley.

WE very much regret to record the death at the age of 54 of Mr. S. ARCHIBALD VASEY, F.I.C., F.C.S., who was for thirty years consulting analytical chemist to the *Lancet*. For a long succession of years he attended regularly the annual meetings of the British Medical Association, and his interest in the Annual Exhibition of Foods and Drugs made him a familiar figure to many members of the medical profession. Mr. Vasey was an able chemist, a fluent writer, and the most kindly and agreeable of companions; his genial personality endeared him to a wide circle of friends. He died at his home in Bromley, Kent, on January 7th.

Universities and Colleges.

UNIVERSITY OF OXFORD.

THE next examination for the Diploma in Ophthalmology will be held on July 18th. Full particulars of courses of instruction, which commence on April 25th, can be obtained on application to Mr. P. H. Adams, Margaret Ogilvie Reader in Ophthalmology, 53, Broad Street, Oxford.

UNIVERSITY OF LONDON.

A MEETING of the Senate was held on December 15th, 1920. The following were recognized as teachers of the University in the subjects and at the institutions indicated:—*King's College*: Dr. Orlando Inchley (Pharmacology). *St. Bartholomew's Hospital Medical School*: Mr. T. P. Dunhill (Surgery). *St. Mary's Hospital Medical School*: Dr. C. McLoran Wilson (Medicine). *National Dental Hospital and College*: Mr. J. H. Oudley Buxton (Dental Surgery), Mr. A. B. G. Underwood (Dental Anatomy).

Sir Cooper Perry was appointed a member of the King's College Delegacy for the remainder of the period March 1st, 1920, to February 28th, 1921, in succession to Sir Charles J. Lyall, deceased, and a member of the Central Council of the Federated Superannuation System.

The annual report of the Graham Legacy Medical Research Committee, giving particulars of the general progress of the laboratory, was received, and Professor A. E. Boycott, F.R.S., was reappointed director of the laboratory for one year from January 1st, 1921.

It was decided to institute a university chair of anatomy at St. Bartholomew's Hospital Medical School.

It was resolved that a candidate for the Diploma in Psychological Medicine who has passed the examination of M.D. in Branch III, Mental Diseases and Psychology, be exempted from examination in psychology and psychological medicine, and be awarded the Diploma in Psychological Medicine on satisfying the examiner for the diploma in Part A (i), "Anatomy, histology, and physiology of the nervous system," and Part B (i), "Neurology."

Dr. F. R. Fraser, as already announced in the JOURNAL, has been appointed to the university chair of medicine, tenable at St. Bartholomew's Hospital for a period of four years from October 20th, 1920.

The William Julius Mickle Fellowship of the value of £200 has been awarded to Miss Harriette Chick in recognition of her important work on diseases due to defective nutrition.

The University medal at the M.B., B.S. examination (October, 1920) has been awarded to Mr. Ronald M. Handfield-Jones of St. Mary's Hospital.

SOCIETY OF APOTHECARIES OF LONDON.

THE following candidates have been approved at the examinations indicated:

SURGERY.—S. Davies, R. F. Divecka, W. Kilroe, J. M. Melgrave, J. B. Williamson.

MEDICINE.—S. Davies, L. Dinerstein, C. T. Gasking, H. D. L. Jones, R. J. Little, E. R. D. Nagel, W. R. Ranson, C. Verheyden.

FORENSIC MEDICINE.—S. Davies, R. J. Little, S. E. J. Miedema, W. R. Ranson, B. W. Roffey, C. Verheyden, J. B. Williamson.

MIDWIFERY.—J. H. Cooper, S. Davies, S. E. J. Miedema, M. Tcherny.

† Section I.

† Section II.

The diploma of the Society has been granted to Messrs. S. Davies, R. F. Divecka, R. J. Little, E. R. D. Nagel, and W. R. Ranson.

The Services.

HYGIENE IN THE ARMY.

A RECENT Army Order provides for the establishment of command schools of hygiene at Aldershot (when the transfer of the school at Blackpool is effected); Hertford Barracks, Hertford; Strensall Camp, near York; Dregghorn Camp, near Edinburgh; Hulsea Hutments, Portsmouth; and Carrickfergus. These schools are to be permanent centres of instruction for staff and regimental officers and for regimental sanitary personnel; and they will maintain close liaison with neighbouring units in order to facilitate the demonstration of the principles of practical hygiene on model-lines. Four classes for officers will be held annually, and the classes for regimental non-commissioned officers and men will extend over a period of three weeks. Classes for personnel of the Royal Air Force will run concurrently with the army classes, and Territorial Force sanitary companies will be attached to the command schools for instruction during their period of training.

DR. A. J. H. MONTAGUE, Commandant of the Workshop Nursing Division (N.A.D.) since its inception, and Mrs. Montague as lady superintendent, have, on the occasion of Dr. Montague's retirement from active practice, been presented by the members thereof with a Doulton-ware dinner service as a mark of their esteem.

Medical News.

THE committee of the Royal Medical Benevolent Fund Guild, anxious to devise new means of obtaining the financial support so greatly needed, recently gave a dance at the house of Sir St. Clair Thomson, who generously bore all the expenses, including a band and refreshments. The Guild benefited to the extent of over £100. Anyone inclined to follow this generous example should communicate with the Secretary of the Guild, 19, Portland Place, W.1.

A SPECIAL course of systematic lectures and clinical demonstrations will be given at the National Hospital for Diseases of the Heart, Westmoreland Street, W.1, on Mondays, at 5.30 p.m., commencing on January 17th.

THE course of lectures on the History of Science at University College, London, was resumed on January 12th, when Dr. Wolf gave an introductory lecture on the general history and development of science. On Tuesdays at 5.15 p.m., beginning on January 18th, Dr. Charles Singer will lecture on the history of the biological and medical sciences from early times to the eighteenth century: his course on the development of medicine in modern times will begin on Monday, March 7th, at the same hour.

A COURSE of twelve practical demonstrations on the management and feeding of infants and young children will be given by Dr. Eric Pritchard at the St. Marylebone General Dispensary, Welbeck Street, W., on Tuesdays and Thursdays at 10.30 a.m. and 3 p.m. respectively, commencing on January 18th. The fee for the course is £2 2s. Opportunities will be afforded to those attending the course of visiting, on Saturday afternoons, the Nursery Training School, 1, Welgarth Road, Golders Green, and seeing the methods employed in dealing with infants.

A NEW publication, *The American Journal of Hygiene*, is announced to appear this month. The editor is Dr. William H. Welch, and he will have the assistance of twenty-three colleagues at Johns Hopkins University and elsewhere, and with Dr. Charles E. Simon as managing editor. The new journal is supported by the De Lamar Fund of the Johns Hopkins University, and it will be published by the Johns Hopkins Press, Baltimore. Its object is the publication of papers representing the results of original investigations in hygiene, using this term to cover all applications of the mathematical, physical, chemical, medical, and biological sciences to the problems of personal and public hygiene. It is proposed to issue at least six numbers a year, and the price, post free, will be 6.00 dols. a volume at home, 6.25 dols. for Canada, and 6.50 dols. in other countries.

INQUIRIES have been made regarding the continuance of the Maudsley courses for a diploma of psychological medicine. We are asked to state that, if sufficient applicants are forthcoming, Part I of the third course of lectures and demonstrations will be commenced in April. Intending applicants should communicate as soon as possible with the Director, Pathological Laboratory, Maudsley Hospital, Denmark Hill, S.E.5.

ON Wednesday, January 19th, at 5.30 p.m., in the Psychological Laboratory, King's College, Strand, Dr. William Brown will begin a two-terms' course of weekly lectures and demonstrations on experimental psychology for medical men who are preparing for the diploma in psychological medicine. The class is limited to ten members, and intending applicants should write at once to the Secretary, King's College, Strand, W.C.2, for particulars of fees, etc. Dr. Brown's opening lecture on psychopathology on Tuesday, January 18th, at 5.30 p.m., will be entitled "The structure of the normal personality."

A VENEREAL DISEASE COMMISSION was dispatched in September, under the aegis of the Colonial Office and the National Council for Combating Venereal Diseases, for the purpose of assisting local authorities in attacking the problem of venereal disease in the West Indies. In Jamaica local organizations are already carrying out propaganda work under the auspices of the National Council, and in Trinidad a branch is in process of formation.

VOLUME I of the fourth series of *Guy's Hospital Reports*, under the general editorship of Dr. A. F. Hurst, will shortly be published by the Oxford Medical Publications.

THE second Congress of the History of Medicine will be held at Paris in August, 1921.

THE twentieth annual report of the Canadian Association for the Prevention of Tuberculosis has just been published. It contains reports of the local anti-tuberculosis societies

throughout the Dominion, which appear to be carrying on a great deal of valuable work with commendable keenness. The report includes also the transactions of the annual meeting of the association which was held at Vancouver in June, 1920, when papers were read by the president, the Hon. F. L. Schaffner, M.D., and others, and interesting discussion took place. In Vancouver itself the initiative was taken and the necessary funds raised for the well-equipped new tuberculosis dispensary now in existence there by a local business men's social club of only 150 members, the Rotary Club, which handed the dispensary, when completed, over to the city.

ON January 5th Dr. Smart Evans of Cardiff was charged before the stipendiary magistrate for making a false return in a vaccination certificate. According to the legal representative of the board of guardians, Dr. Evans, after vaccinating a child, had immediately certified that the operation was successful. The defendant was committed to the Glamorgan assizes, personal bail being accepted in a sum of £50.

Letters, Notes, and Answers.

As, owing to printing difficulties, the JOURNAL must be sent to press earlier than hitherto, it is essential that communications intended for the current issue should be received by the first post on Tuesday, and lengthy documents on Monday.

ORIGINAL ARTICLES and LETTERS forwarded for publication are understood to be offered to the BRITISH MEDICAL JOURNAL alone unless the contrary be stated.

CORRESPONDENTS who wish notice to be taken of their communications should authenticate them with their names—of course not necessarily for publication.

AUTHORS desiring reprints of their articles published in the BRITISH MEDICAL JOURNAL are requested to communicate with the Office, 429, Strand, W.C.2, on receipt of proof.

IN order to avoid delay, it is particularly requested that ALL letters on the editorial business of the JOURNAL be addressed to the Editor at the Office of the JOURNAL.

THE postal address of the BRITISH MEDICAL ASSOCIATION and BRITISH MEDICAL JOURNAL is 429, Strand, London, W.C.2. The telegraphic addresses are:

1. EDITOR of the BRITISH MEDICAL JOURNAL, *Aitology, Westrand, London*; telephone, 2630, Gerrard.
2. FINANCIAL SECRETARY and BUSINESS MANAGER (Advertisements, etc.), *Articulate, Westrand, London*; telephone, 2630, Gerrard.
3. MEDICAL SECRETARY, *Mediseca, Westrand, London*; telephone, 2630, Gerrard. The address of the Irish Office of the British Medical Association is 16, South Frederick Street, Dublin (telegrams: *Bacillus, Dublin*; telephone, 4737, Dublin), and of the Scottish Office, 6, Rutland Square, Edinburgh (telegrams: *Associate, Edinbuigh*; telephone, 4361, Central).

QUERIES AND ANSWERS.

"R. M. P." writes: Is there any special arrangement amongst the medical practitioners in Letchworth, Herts, with regard to the conduct of private practice in that town?

No information as to any such special arrangements has reached us.

DISEASES OF THE NAILS.

"H. R. H." asks for advice as to a textbook on diseases of the nails: most of the dermatology books give only brief outlines. He asks also for suggestions as to treatment for splitting of the nails in a healthy middle-aged woman in whom there is no suggestion of gout. The nail from the lunula to the extremity suddenly becomes painful to the touch, then a red streak appears which in a day or two forms a distinct fissure. This occurs from time to time in different nails.

A good account of disease of the nails may be found in Allbutt's and Rolleston's *System of Medicine*, vol. ix. To suggest remedies for the condition complained of is difficult, as in many cases the affection of the nails is only symptomatic. Probably some benefit would be obtained from the use of an ointment of oil of cade m xx in salicylic acid ointment 5j. At the same time, mild application of x-rays should be given, about one-half pastille or less every two weeks for four exposures.

LETTERS, NOTES, ETC.

NAME FOR ACCESSORY FOOD FACTORS.

DR. JOHN BROWN (Blackpool) writes: The name vitamins was given for the accessory food factors. We know now that the word is absolutely misleading. We need another or alternative name. The following have been suggested: Biogens, biofers, and vitagens; vitafer, vitoids, vitases; vitines, advitans, etc. I have submitted these names to several medical men. The following have been suggested: Biogens, biofers, vitagens, vitoids. At the Cambridge meeting of the British Medical Association, when vitamins were discussed,

I used the word "vitoids." Personally, I believe *biogens* is preferable. It agrees with many words derived from bios, such as biology, bioplasm, biological, biogenetics, biography, etc. It is not too late to adopt a new word.

DELIVERY OF CHILD AND PLACENTA IN UNRUPTURED MEMBRANES AT TERM.

DR. JOHN WISHART (Newcastle-upon-Tyne) writes: Following the memorandum by Dr. J. H. Gilbertson in the *BRITISH MEDICAL JOURNAL* of October 23rd, I may say that out of 4,000 midwifery cases during the past twenty years I have had only two such cases as detailed by him. Is it possible that Nature, at one time, delivered all cases in unruptured membranes, and that the present procedure of rupturing membranes at the end of the first stage is wrong?

A NEEDLE IN A SEMILUNAR CARTILAGE.

DR. JOHN R. HOWITT (St. Joseph's Hospital, Hamilton, Ontario, Canada) writes: The following case seems worthy of record. A man, aged 31, was admitted to hospital for operation for a dislocated left external semilunar cartilage. The patient had been sitting on a piano stool about a month ago when, on turning round, he slightly twisted his knee. A sharp pain came on which lasted nearly a week, and he could scarcely walk. At the same time he noticed a lump which appeared whenever he flexed his knee. Both the pain and the lump recurred again at intervals several times afterwards. He was operated upon by Dr. Olmsted, and the cartilage was removed. Buried in the cartilage itself and also projecting in part into the lower surface of the joint was a blackened piece of needle about 1½ inches long. The patient, on being questioned after the operation, stated that he had a hazy recollection of having swallowed a needle when a child. He was positive no needle had ever penetrated him otherwise; the only conclusion, therefore, is that the needle recovered in the excised cartilage at operation was the one he had swallowed about twenty-five years before.

TUBERCULOSIS.

DR. J. S. PEARSE (Plymouth) writes: In your leading article on this subject on p. 907 you state: "Virgin subjects" (rural dwellers transferred to towns and certain native races) succumb to severe and rapidly fatal forms when first exposed to massive doses at close quarters." Do rural dwellers drink tuberculous milk? Are they more immune to tuberculosis than town dwellers? Why should they not become infected by bovine tuberculosis as the town dwellers are supposed to be?

Here is the history of the family of A. B., the members of which reside in a village in Cornwall. His father and uncles died of tuberculosis. A. B. and his brothers died from tuberculosis, all residing in the same village and neighbourhood. His sisters are all living, over 60 years of age. One is a very stout and big woman, another thin, active, and wiry, subject to rheumatism. A. B. had six sons and four daughters. One son in his twenties came to Plymouth in business, married, and shortly after died from tuberculosis. The youngest son, tall, and apparently healthy and clever, won a school scholarship and went to college. Shortly after he also died of tuberculosis. The remaining four sons reside in the village. One is a very stout man; another very tall, thin, and wiry; the other two are delicate. The four daughters also live at home in the village—all over 30 years of age, are well built, strong, and healthy-looking.

This family of rural dwellers would probably not be described as "virgin subjects," but there are those who would say so, because the two sons who left home died from tuberculosis. But if the bacillary theory is to hold good, they should have been immune to the disease apparently. All the six sons show derangement and irregularity of metabolism and growth, indicating want of co-ordination and activation of the endocrine glands. Would this be attributable to the presence of toxins of tuberculosis in infancy and childhood, or in their father affecting the sperm and germ cells? A curious fact is that the female members of the family appear to have escaped tuberculous infection, or clinical evidence of it.

According to the statement made by Sir Dyce Duckworth, a rheumatic diathesis is inimical to tuberculosis, and it is also stated that an individual who is bald is not likely to contract tuberculosis. It would not be out of place to say that the action of the endocrine glands has an all-powerful effect upon the development and incidence of tuberculosis.

MOTOR SCOOTERS.

IN the *BRITISH MEDICAL JOURNAL* of November 27th, 1920, under "Queries and Answers," we published a note on motor scooters in which we said that this type of vehicle probably has a future, but that at present it is not possible to speak with confidence. More recently we have had the opportunity of examining a machine called *The Whippet*, made by Messrs. W. G. C. Hayward and Co. of Beaufort Works, Twickenham. We are inclined to think that under certain conditions and in some practices this scooter may prove of considerable service. In large towns it is possible that the greater dignity in progression conferred by the car may appeal to practitioners. But in the suburbs and in rural areas, especially if the roads are tolerably good, the scooter may well prove useful, whether for habitual use or as acces-

sory to the car, and this view is confirmed by a medical man who is now using one of these scooters. The engine, four-stroke, 1½ h.p., is fitted with an exhaust valve lifter in order to make starting easy. The wheels are broader than usual, and fitted with 18-in. tyres. The frame is very strong and is stated to have carried the weight of three persons. The strength of the frame and the size of the wheels are the main points which suggest greater reliability and usefulness as compared with some of the lighter machines. The seat is well sprung and very comfortable. A speed from three to twenty-five miles per hour is obtainable, and the petrol consumption is stated to be at least 100 miles to the gallon. The mechanism is very simple, and the scooter is said to be able to climb any hill. Economy in initial cost, in upkeep, and in mileage to the gallon of petrol and oil are points in favour of making the vehicle popular, especially in view of the car taxation now coming into force. An objection to the machine is that in rainy weather the rider will need the same sort of protection from wet and mud as is needed by the rider of an ordinary motor bicycle. Further, the greasiness of wood pavements, especially where there are tram lines, will probably render great care necessary in riding. The latter objection, however, applies to all rubber-shod vehicles.

AN IMPROVED EMBEDDING MEDIUM.

DR. C. LOVELL writes from the Pathological Laboratory, Bethlem Royal Hospital: We have recently been using a new embedding medium, which may be of use to some of your readers. One part, by weight, of beeswax, is added to five parts, by weight, of paraffin wax (m.p. 50° C.). The whole is melted together and filtered in the hot air sterilizer. The medium gives excellent results with nerve sections. The beeswax gives sufficient tenacity to prevent any crumbling. The mixture melts at 51° C. to 53° C., and cuts smoothly at any temperature.

CATALOGUES.

WE have received from X-Rays, Limited (11, Torrington Place, London, W.C.1), a list of electro-medical appliances with prices, including the most recent models on the British market. Although a sectional catalogue, from which X-ray apparatus is excluded, it is most comprehensive, and in its hundred pages will be found described apparatus and accessories for use in electrical methods of testing and treatment, as well as such things as surgical lamps and electric sterilizers.

WE have received from the Edison Swan Electric Company (Limited), of Ponders End, Middlesex, a copy of a new list of "Ediswan" apparatus for obtaining the currents required by the radiologist. The principal feature of the catalogue is a series of induction coils which are described as "jointless section" owing to the principle adopted for the winding. The transformer or interrupterless machine also figures in the list, and there are various interrupters of well-known types, as well as portable accumulators for use where no electrical supply is available, and motor generators for supplying direct current where the mains give an alternating supply. This range of apparatus, together with switchboards mounted on trolleys or otherwise, may be seen in demonstration at the firm's showrooms in Queen Victoria Street, London.

IN these days of high building costs, the value and cheapness of wooden buildings—for example, bungalows, motor-car houses, poultry houses, is often overlooked. The new catalogue of Messrs. T. Bath and Co., 18, Savoy Street, is therefore worthy of reference.

VACANCIES.

NOTIFICATIONS of offices vacant in universities, medical colleges, and of vacant resident and other appointments at hospitals, will be found at pages 33, 36, 37, 38, 39, and 40 of our advertisement columns, and advertisements as to partnerships, assistantships, and locum tenencies at pages 34 and 35.

THE appointments of certifying surgeons at Arundel (Sussex) and Long Buckby (Northampton) are vacant.

SCALE OF CHARGES FOR ADVERTISEMENTS IN THE BRITISH MEDICAL JOURNAL.

	£	s.	d.
Six lines and under	0	9	0
Each additional line	0	1	6
Whole single column (three columns to page)	7	10	0
Half single column	3	15	0
Half page	10	0	0
Whole page	20	0	0

An average line contains six words.

All remittances by Post Office Orders must be made payable to the British Medical Association at the General Post Office, London. No responsibility will be accepted for any such remittance not so safeguarded.

Advertisements should be delivered, addressed to the Manager, 429, Strand, London, not later than the first post on Tuesday morning preceding publication, and, if not paid for at the time, should be accompanied by a reference.

NOTE.—It is against the rules of the Post Office to receive *post-restante* letters addressed either in initials or numbers.

An Address
ON THE
**APPLICATION OF THE PROFESSIONAL
LESSONS OF THE WAR TO
CIVIL WORK.**

BY
SIR HENRY M. W. GRAY, K.B.E., C.B., C.M.G.,
F.R.C.S. EDIN.,
SURGEON TO ABERDEEN ROYAL INFIRMARY.

THE subject of my discourse is one with very many sides to it, and can be appreciated fully probably only by those who saw service under the most varying conditions during the late war. I have no doubt that many of you have interested yourselves already in some of the things of which I shall speak. I crave the forbearance of specialists in medical politics, but at the same time I hope that I may be able to interest every one in some measure. In an educational centre like Dundee the results of teaching, especially such as were revealed under the stress and stimulus of war, when the minds of men were strung to a high pitch, must always be of surpassing interest. It is really the study of these results and a desire to help in improvement which has led to this address. That there is room for improvement in medical education and in facilities for work in civil life was, I am sure, appreciated by us all when we were face to face with the difficulties of war work. I am equally sure that we were not troubled with the big aspects of things so much as by the working out and application of details, without which big things were impossible. The well trained man pays attention to details. It is only the exceptionally capable man who in later life can surmount shortcomings of education and compete successfully with his better trained fellows. Judging from my experience in the war, I claim this power for the average medical graduate of Scotland, and on that account I venture to refer to the disadvantages of his present-day education in a somewhat forcible way. In saying that, with a better education, his prowess in the arenas of the world would be far more striking, I acknowledge again that I belong to the ultimate division in the Sassenach classification of those north of the Tweed the Scotsman, the damned Scotsman, and the Aberdonian!

From the outset I wish you to keep in mind the fact that the problems of treatment, both preventive and curative, are virtually the same for the civilian at home as for the soldier in the field, and differ only in the urgency of appeal to our sentiments and to our best efforts. The honest civilian worker, whether of high or of low degree, should be regarded as doing equal service for his country under the conditions of peace as the soldier in war, although the latter, in the strenuous and dangerous conditions of the battlefield, appeals to our emotions in greater degree. The civilian worker is a combatant in the nation's fight for existence, and as such is valuable to the nation in proportion to his activities, and deserves as great consideration as the soldier when he is disabled. Sentiment has not, unfortunately, hitherto stirred the nation to proportionate effort on his behalf.

Civilian Need in Peace.

It has required the stimulus of a ghastly war to produce unprecedented efforts on behalf of the disabled soldier. It is to be hoped that equally strenuous efforts on behalf of the civilian will be forthcoming, but meantime it is regrettable that apparently, as soon as the war is over, the nation should again become apathetic. Instead of there being a general clamour for the very best possible treatment for the civilian worker, and for the provision of the best possible conditions and other facilities for that treatment, voices are being raised only here and there, officially or unofficially, in an attempt to maintain in civil life the high standard which was striven for and achieved by many during the war.

Of course there are great Government schemes in the making which aim at the organization of the medical service of the country, but these were being promulgated

before the war, and one cannot judge of them until they have been tried. My remarks apply especially to the everyday work of the medical man, be he general practitioner or specialist; but you will, I am sure, appreciate the necessity for having adequate organization to regulate such work, although, like myself, you may not be convinced that a State medical service will be altogether a good thing for the patient. Service controlled by "red tape" has its disadvantages as well as its advantages.

*Improvements in Military Medical Work
in France.*

I have said that the stimulus of a ghastly war produced unprecedented efforts on behalf of the wounded soldier, but we cannot blind ourselves to the fact that these efforts fell considerably short of the ideal. In my position as a consultant surgeon in France I could well appreciate the difficulties which stood in the way there of attainment of the ideal, but the influences which led to the vast improvement in the treatment of the sick and wounded soldiers were also apparent, and some of them may be gleaned from the remarks I am about to make. I cannot speak too highly of many individual as well as concerted efforts which resulted in immense improvement in overcoming, and still more in preventing, the terrible sepsis which at first thwarted the efforts of men who had been trained practically entirely under conditions which gave them no experience of the ravages which such sepsis could produce in an incredibly short time. It was not to be wondered at that, at first, adverse criticism of the surgical work in France should be expressed, but I assert, in reply to such criticism, that the critics could not possibly grasp in their minds either what had to be tackled or the conditions under which the work had to be done. The work in these early days was most discouraging in its results, the conditions under which it was carried on were often most unfavourable, and the numbers of wounded were frequently so overwhelming as to fill the stoutest hearts with despair. The wonder to me is, on looking back, not that so many severely wounded men arrived on this side of the Channel in a precarious septic state, but that so many arrived alive.

In reverting to the thesis that the civilian worker should be regarded as a combatant for the nation's welfare, I may be excused if I soliloquize a little on present-day conditions. War is, after all, but a hideous expression of antagonism of communities which has become so concentrated that it gets beyond control. In peace times controlled antagonism is called competition. This when under reasonable and equitable control is good and makes for advance, but when unreasonable and inequitable it really results in war; although of a less obtrusive and apparently milder type, yet, in its less direct and less apparent way, it may have equally disastrous results to the individual or section of the community which goes under. The late world war has been followed by intense resentment on the part of many workers who were in the past unjustly treated—it has driven many patriotic employees to recognize the justice of the claims put forward and to try to meet them. There has arisen a clamour for a reconstruction of relationships which has been, on the one hand, too hastily and too forcibly and unreasonably expressed to enable the balance to be preserved, and has resulted in a chaos which threatens the commercial prosperity and the health of the nation to an incalculable extent. It is a big thing to say, although it is easy to say it, but I believe that the present state of affairs is due to a want of education, and therefore of fulfilment, on the part of employers as well as of employees, of their responsibilities to each other, whether as private individuals or as members of the greatest nation and empire of the world. The application of the remedy is a difficult matter.

Although the members of the medical profession as a whole can, in virtue of their calling, claim in the past to have been probably more altruistic than any other class of workers—except, possibly, that of the allied very noble nursing profession—and although we may have constantly striven for better knowledge of disease, and for its more adequate treatment, yet the war has taught us many lessons which ought to be turned to great advantage to the sick and suffering. In putting my opinions before you I am deeply sensible that they may not agree with those of other men and women whose experience and judgement command attention.

* An address to the Dundee Branch of the British Medical Association, December 15th, 1920.

The rank and file of the medical profession are those splendid general practitioners who do the spade work and the hard fighting, and who count for most, after all, in the medical world, just as the equally splendid infantry soldiers of the line regiments were the men who, after all, counted most in the great war against the Boche and his dupes. But I do not think that the majority of our rank and file are paying enough attention to the application in their daily work of these important lessons which, when properly learned and applied, will help professional work to be better done, more easily done, done with greater satisfaction and happiness to ourselves, and consequently with greater benefit to the patients whom we attend. I mention general practitioners especially, as they form the backbone of the profession, and there must be a sound, efficient, active, well co-ordinated backbone in order that the body may make progress. That is why I think in medical schools like Dundee and Aberdeen, whose function it is especially to produce general practitioners, great care should be taken that those in charge of the training of students be not overtaxed, as I venture to think is occurring just now because of the too large number of students.

It is impossible, under the conditions at present existing, for example, in Aberdeen, to teach clinical work to the average student as it ought to be taught. It is impossible to give that individual attention to each student which clinical teaching demands. The education is perforce imperfect. It is the same meantime all over the country, and, unless the student exerts himself to an unusual extent in his efforts to acquire knowledge, there is a danger that this imperfection may lead to evil results and a temporary degradation of the profession.

I say again that I want you to appreciate that civil work can be compared in all respects to war work. The working class, whether performing skilled or unskilled labour, the so-called middle class with all its widely varying occupations, the upper class—all have their representatives in the navy and army, and although a few people did mighty little in both of these services during the war, the only class which did not have its counterpart is that comprising the idle rich. The citizen, the civilian worker, is to be regarded as a combatant fighting for the nation's welfare, and he should be educated and kept fit for his warfare just as carefully as the soldier. In certain circumstances he may require equally intensive training. As I have indicated already, I do not think he has been sufficiently educated to appreciate his responsibility at this time to put forward all his ability in making up for the waste of war, and there is too little realization of what this is leading to. Students can realize that if they do not work they will not pass examinations which loom in the future. If our nation does not work it will fail in an equal measure. The world's economic state demands an increase in effort all round. There are big proposals being mooted or set agoing to improve conditions of life, but unless the masses of individuals—for example, our general practitioners—bestir themselves to help out these schemes they cannot succeed as they ought.

The civilian must be kept in good health for his work in his particular fighting line, whether in the street, shop, or factory, and if disease or accident should overtake him, he must be made fit again to join his unit as soon as possible. In my experience during the war the surgical arrangements made for the fulfilment of these responsibilities to the soldier were wonderfully and increasingly well developed. The stimulus of war in its ordinary sense is not now present in the minds of the populace to enable us to obtain and maintain equally good and progressive provision for the civilian. It is difficult in this country to make the public see the economic importance of having the very best and fullest provision for the treatment of the sick and wounded civilian combatant. Even yet it is only here and there that the monetary value of good research work is appreciated. All ranks in our profession must join in an increasing effort to educate the people.

Time will not permit me to do more than touch upon the many facts of war work from which we can learn. If my remarks may seem at times somewhat curt and savouring of want of reverence for established customs, I tender a desire for brevity as my excuse, and hope that they will be taken in the spirit in which they are offered; I would add that my criticisms are directed against systems, not against individuals, as I fully realize the

possibility that some might consider that I myself should be included in the criticisms.

In my position as consultant in France, both in a large base area and in an important and oftentimes very active army and later as a consultant in special military surgery in the home service, I had ample opportunity of studying things from many points of view, and the following remarks are the result of my cogitations.

Their Applications in Civil Life.

When a man failed to make good in the army—that is, when he failed to keep pace with the standard set by the majority of other men in similar positions—he was replaced by a more likely man. Under stress of war at the front no post could be maintained for long unless good work was done. Here is our first lesson. Should not the same rule be applied to those in responsible positions, and especially in our schools of learning and in our hospitals? Yet we find that, in some of our universities, men are appointed for life to such positions and remain in office for as long as they alone see fit. Surely this is carrying the principle of "security of tenure" too far! It is absurd that in the most important posts connected with teaching the stimulus of reasonable competition should be excluded during the lifetime of the occupant of the particular appointment concerned. There can surely be found a satisfactory method of control, even although it may require an Act of Parliament to bring it about, whereby, if the standard set by occupants of similar posts elsewhere is not maintained, the delinquent could be deposed from the responsible position which he occupies. I may say that the memory of my experience in the war does not make me tolerant of those who fain would stick to inadequate arrangements merely because they are antiquated.

The stress of war, in that it revealed the necessity for making a combatant efficient again as soon as possible, gradually forced the authorities in control of the purse-strings of the nation to loosen these strings where provision of hospitals and suitable hospital equipment was concerned. I can say that the state of some of the casualty clearing stations and I speak only of those under my supervision—even within a few miles of the fighting line in France, both in housing and in comfort, as well as in arrangements for professional work, were such, at the period before disorganization was caused by the German advance in March, 1918, that I would have preferred to be treated as a patient in one of them than in many of our hospitals at home. If such perfection was possible under conditions of war at the front, surely it ought to be more than possible under the peaceful conditions of this country. But the question of money and our innate conservatism stand in the way. Purse-strings must be loosened to a greater extent, generosity in subscribing for medical and surgical requirements must be more widespread—those who cannot give in money can give in labour if we are to advance as we ought to. Bigger, broader, more far-seeing ideas must be cultivated. This aspect of affairs is of acute interest in Aberdeen at present in connexion with the development of a big scheme which is being brought forward to improve our hospital service, teaching facilities, and opportunities for clinical study, as well as to conserve expense of working and the time of medical men and students. The scheme includes concentration of the hospitals of the city in one large compound, transference of certain departments of the university to the same site, and, finally, provision of a hostel for senior students, so that they may be on the spot to take advantage of experiences from which meantime they are largely debarred. It seems to me that intending subscribers to such a scheme may hold back on account of the uncertainty which is felt with regard to the future relationship of the Government of the country to hospitals generally. The Government should declare its policy clearly and firmly, and without delay, so that private individuals may know whether they have to undertake the responsibilities, and to what extent.

One of the great developments in connexion with the medical service of the war was that of "team work." The advantages of this were already demonstrated in civil life, notably on a large scale in the Mayo clinic in America, but little more than the talking stage had been reached in this country, and that only in very few centres. It was carried into actual practice, so far as pure surgical work was concerned, at the battle of Arras in April, 1917, and

its success was at once established by the fact that the number of operations then performed in proportion to the number of wounded was largely increased when compared with former battles, and the improvement in results was also very marked. In association with the establishment of surgical teams the whole working of the clearing stations was so organized that all the different departments of these hospitals were more closely linked up, and by the collaboration of the medical officers in charge of these departments the work as a whole was more efficiently and smoothly performed than ever before. Physicians, bacteriologists, skiagraphists, surgeons, administrative officers, nurses, orderlies, stretcher-bearers, cooks—all worked whole-heartedly, and, so to speak, hand in hand as a big team for the general good of the wounded soldier. Antagonism was barred, friendly competition and pride in work were paramount. It was found that the success of any team was proportionate to the driving force of its chief member. While it cannot be said that there is want of collaboration, for example, in such an institution as our Aberdeen Royal Infirmary, and even although there is a tendency to develop the team spirit in some quarters, yet there is a good deal left to be desired. This is not the fault of the medics concerned, but rather of the conditions of work. I am afraid, however, that I must not discuss this matter further at present, except to say that the appreciation of the value of the system is reflected in the frequency with which the term "team work" is used in our everyday life. Seeing that no single individual can be expected to have accurate knowledge of all branches of his profession, "team work" amongst general practitioners is as desirable as in hospital practice.

Age and Youth.

The most striking phenomenon of the war to my mind was the way in which the young man came to the front. As time passed, positions of great importance became filled with increasing frequency by young men, and I believe that if the war had lasted another year, only a very few old men would have been left in France and Belgium, where the main issue lay, and these would have been old men who had remained young. It was remarkable that as the young men or the young old men got more power into their hands the work was better and more quickly done. It was being shown that there was no room in that strenuous field for the man whose faculties were so inert that he could not accommodate his outlook to, or keep pace with, the rapid developments which had to be made in order to cope with the kaleidoscopic changes occurring in such rapid sequence.

Is it not really exactly the same in civil life? Especially at such times as the present, can the nation afford to have obstructionists, whether passive or active, to what should be a strong stream towards success? A strong stream, when its passage is set in turbulent surroundings, entails eddies and backwaters. There are adornments to such eddies and backwaters which are out of place in mid-stream! It is but rarely that the old man, or the "dud" man, can appreciate the fact that he is getting old or that he is a "dud," and that he should step aside to let the junior or the better man have greater sway, and even if he does appreciate it, he can sometimes succeed far too long by his clever camouflage and much speaking. As I have said, the events of the war showed how well the young man could shoulder responsibility and how rapidly he developed sound judgement, foresight, and adaptability in the management of affairs. In the category of old men, as I have already hinted, I do not include him who, in spite of his seniority, could maintain his zeal, earnestness, and thoroughness when at work, who could tough it with the young men, and who could become young again in his off-times, and even play the fool on occasion with the most skittish of the youngsters. Such a man exerted a tremendous power for good among his younger colleagues. He was looked up to and his opinion and approbation were eagerly sought by them. It is such men whom we should cultivate and continue to honour when they retire to the less turbulent parts of the stream. A great truth, which was revealed to me more strongly than ever before by my experiences in the war, was that by trying to help on the younger men one helped oneself. I believe that I can say truly, and I say it in all humility, that when the young surgeon and his colleagues in France found that I was really "out" to help them in their work to the best of my

ability, they responded with a loyalty and devotion in carrying out suggestions which were most gratifying. Any kudos which accrued to me during my time in France was due to that spirit amongst these young men, and I shall cherish the privilege and honour of having served along with them.

Continuity of the Best Treatment.

The importance of developing means of ascertaining and establishing everywhere the best methods of treatment and of procuring continuity in treatment was increasingly impressed on everyone as time went on. During prolonged battles, which entailed stupendous, unceasing effort on the part of medical officers, it was impossible that they could keep abreast of the advances in knowledge which were occurring unless special provision were made. It was in this respect that the consultants could perform probably their most important function. They could encourage and direct investigation, and by carrying information from one place to another, by actual demonstration in one hospital or by informal conversations or special lectures in another, by stimulating men to meet and to discuss new problems, and by promoting collaboration between workers in units at the same stages and at different stages of the wounded man's progress, they could exert an enormous influence for good. The institution of consultants at home with the powers of those in the army may probably be resented at this stage of our civil professional development, but I cannot help thinking that the needs of all busy members of our profession are not quite so adequately catered for in this way as they were in France, and as they would have been still more had time allowed the aspirations of the consultants to be applied and developed more fully.

Collaboration between units of the actual fighting area and the casualty clearing stations, between the latter and the hospitals on the lines of communication in France, and between these again and the hospitals at home, practically did not exist until the war was well advanced. Communications from home hospitals or from hospitals down the line were almost entirely in the form of complaints as to the condition of the patients who had previously been treated under circumstances of stress and difficulty such as the complainants could not possibly visualize. On the other hand, medical officers of the more advanced units were rather inclined to despise others in so-called soft billets further removed from the fighting line, and to resent complaints from them, while advice from the same sources was almost equally unacceptable. I need not detail the means which were taken to bring about a better understanding, which was attended with happy results wherever it occurred. It is still too often the case in civil life that the hospital physician or surgeon, or even the student, forgetting the disadvantages under which the general practitioner has in many instances to work, is inclined to scoff at the treatment or mistaken diagnosis, which may have had to be made in a hurry—possibly, for example, in a box bed in a squalid cottage, with a spluttering candle as the sole means of light. On the other hand, does the general practitioner always look with favour on the consultant? Sympathy and collaboration are required as much at home as they were abroad.

Defective Medical Education.

The next point which occurs to me I mention almost with reluctance, but I do so because I realize my own shortcomings. One was very frequently impressed with the wonderful knowledge of obscure signs and often of fantastic theories concerning disease or injuries which was thrust at one, and one ought to have felt oneself to be a very inferior worm, but one took heart again at the thought that such phantasms and the "tall" language in which they were described helped not at all in the practical, life-saving problems which were crying out for solution. It was evident that something had been wrong with medical and surgical education when such theorists were found to be unable to dress wounds or apply bandages or splints efficiently. What some of our friends across the water call "horse-sense" of the majority saved the situation. It is a pity that some specialists who occupy teaching posts forget to impart the rudiments of a subject to the students under their tuition and speak to them of exceptional matters in "high-falutin" language, which is repeated in parrot fashion too often without understanding.

The student ought to be well grounded in the simplest, most common, and most useful things which pertain to the practice of his profession, and be taught to think and act for himself. The curriculum tends to become unduly crowded, and there is no time for consideration of subjects which are better suited for post-graduate study. As I have already pointed out, sensible teachers feel that at this critical period of university education each student must try to work out his own salvation, in view of the fact that owing to the unduly large number of students it is impossible to give that attention to individuals which is desirable. The important problem is how best to stimulate self-help, considering that the spirit of the age is so foreign to such a virtue.

It would appear that collaboration between teachers, with the object of eliminating unessential details which merely clog the minds of their students, is required more than ever. How much is the advice of clinical teachers, as to what is most useful, sought by those who deal with subjects like anatomy, physiology, chemistry or physics? Yet these and certain other subjects of study can only be regarded as preparatory to clinical work, and should therefore be adapted more closely than they are to the requirements of the average medical student.

Evils of Systematic Courses.

I cannot refrain from saying that my experience during the war has led me to object more strenuously than ever to the retention of courses of systematic lectures in the medical curriculum of our Scottish universities. These systematic lectures and the slavish taking of notes are relics of bygone ages which ought to be dispensed with. They were necessary even as late as 50 to 100 years ago, when such excellent textbooks as are extant at the present day were not available to the student. How many of us can honestly say that we retain any useful memory of the often wearisome lectures which we were compelled to attend day after day, during which our minds were distracted by the scrambling efforts of our pencils to keep pace with the lecturer, while our evenings were spent in the endeavour to make sense out of our notes and to supplement them with extracts from books? I think that under modern conditions the ordinary course of systematic lectures is very largely a waste of time both to lecturer and student. The professor should discourse much more on principles, leaving tutorial work in matter of detail to assistants. Especially in surgery, but also in certain other subjects, practical instruction should bulk more largely than it does.

Early Treatment and Transport.

The lessons taught by the war in the early handling and transport of patients who are seriously ill demand our very earnest attention. It was too often tragically brought home to workers in France how inattention to apparently trifling details was reflected in the whole subsequent course of a man's illness. For example, improper application of a bandage or inadequate fixation of a splint might result in the loss of a limb or even of a life. Medical officers as well as orderlies had to be trained in the application of specially suitable splints, and in all methods of resuscitation and preventive treatment which could reasonably be carried out in very advanced units. The prevention and curative treatment of shock and haemorrhage and of sepsis were the most important duties which faced the medical officer in these units quite apart from the problems of evacuation. The medical service at the front laboured under the disadvantage, when compared with civil service, in that the interests of the wounded man were subservient to the supply of ammunition, food, and reinforcements to the fighting line. Some of the work done by medical officers under these conditions was beyond all praise; for example, I know of many cases of severe gunshot fracture of the femur—a very deadly injury—which were so well attended to in advanced dressing stations during a big battle, when hundreds of severe cases were passing through such stations in a day, that the patients were passed along comfortably, free from delay and from any detriment, to hospitals in England, without having their original dressings and splints changed.

Lives are lost unnecessarily, even in our biggest towns, from the effects of shock and primary haemorrhage, and in other ways, owing to the want of better organized help. I do not wish in any way to depreciate the efforts of

ambulance societies and such like, but I do think that early arrangements for the patient who is stricken down by a severe injury in the street or at his work suffer in comparison with those which were instituted at the front. For example, what factory has a special aid post where the patient can be specially warmed and otherwise cared for? Are splints specially suitable for transport available? Are special rooms set apart and specially equipped for the treatment of shock and haemorrhage even in the large hospitals of towns where severe accidents are common? Or again, in how many institutions is the routine of unclothing and cleansing a badly shocked patient omitted or modified until he has recovered from his shock? Many other questions in the same vein crowd upon us, and yet we know that, within easy range of shell-fire in France, everything really useful and practicable that human ingenuity could devise was done for similar patients! What was necessary for the wounded soldier is equally necessary for the injured civilian, whether the injury be due to accident or disease.

Again I must revert to the education of the student with regard to these practical matters. Take a question asked the other day as to what occurs in our own medical school, and I may say that the same holds good with regard to some other schools, and the larger the school the less chance is there of really remedying the defect unless the amount of clinical material is adequate. How many students before their graduation have, in their clinical work, actually passed a catheter, given an enema, passed a stomach pump, administered a hypodermic injection, "put up" a fractured limb, or even "made a bed," and so on, or even seen these things done? It is hard for patients to have to be submitted to unpractised although anxious efforts later on, especially when the graduate is not supervised. I remember in my student days how many of us went to the hospital nearly every evening during our service as dressers, and helped the house-surgeon in all sorts of ways. Evidently, so far as Aberdeen is concerned, this custom has practically gone out of fashion. It is to be regretted that clinical teachers there have not greater power over the students. There were comparatively few emergency cases then such as are common nowadays, but we learned a good deal from the treatment of those we did see. Emergencies are admitted most frequently in the afternoon or evening, and are operated on as soon after arrival as possible. Such operations are interesting and very instructive. I wish it could be successfully impressed upon students, and graduates also, that the clamant necessity for prompt treatment of an abdominal emergency cannot be appreciated unless they see for themselves the appalling state of the interior of the abdomen which results from delay.

A Sufficiency of Hospital Beds.

I can touch only very lightly upon a few of the other many lessons of the war. A very striking fact, when one considers it a little, is that a wounded or sick soldier was always provided for at once in hospital when hospital treatment was thought necessary. His name did not go on any waiting list, yet the large waiting lists of the hospitals of this country are regarded with comparative equanimity. The same attitude is apparent with regard to the permanent injury to health, and even to the loss of life, which occur in epidemics of serious illness owing to the fact that skilled nursing under suitable conditions is not available in adequate amount. Sir Napier Burnett has shown that lives were lost in number amounting to several divisions during the influenza epidemic of a couple of years ago. Yet in one instance, where cases complicated by pneumonia were housed in an extemporized building and nursed by volunteers, the death rate was greatly reduced. There should be no greater difficulty in rapidly adapting suitable public buildings in emergencies of that sort than there was in adapting them for hospital work during the war. The need for doing so is equally great when we consider the preventable mortality. Schemes should be drawn up for meeting the requirements of such emergencies.

In these days of inadequate hospital accommodation throughout the country, I wonder if sufficient consideration is given to the class of cases which are permitted to occupy the available beds. Perhaps I can best bring out what I mean by referring to the very important question which cropped up in France during periods of severe

fighting during which surgeons and others were taxed to the uttermost—a state of surgical stress that may be compared quite reasonably to the general great demand for available beds in civil hospitals. The matter I refer to is this: humane feelings, or even the surgical interest of a case, too often led surgeons to misplace their efforts by treating types of cases which required large expenditure of time, and which, after all, gave a low recovery rate. Thus, during a big "push," it was difficult to persuade men to leave abdominal cases—in which under the best treatment, even in so-called "peace times," the recovery rate rarely amounted to more than 50 per cent.—and to attend to other cases which, with timely operative intervention, recovered more rapidly and in far greater proportion, and of which two or three could be treated in the time taken up by one abdominal operation. If such promising cases were left over for a day or were sent down the line, by the time they were submitted to operation infection had gained such a hold that far more extensive measures had to be employed; in any case, a much longer convalescence was entailed, and in many cases even death resulted from the delay, and this even where the timely intervention would have resulted in the patients being fit for duty again in a comparatively short space of time. It was gradually being realized, however, that the exigencies of the military situation and the shortage of surgeons really demanded that the cases with the greatest prospect of recovery should receive preferential treatment, although consideration for the morale of the troops prevented this being carried out to any marked extent. The problem is really the same, when we come to think of it, in our civil practice. Manpower and conservation of time in relation to this ought to be considered more frequently. It is not good policy to sacrifice by delay in treatment any patient suffering from a disease or disability which can be rapidly cured, but which may develop to serious extent during the time of waiting for accommodation occupied by patients who are incurable, or who at best will never be able to display more than a low grade of efficiency. True it is, however, that some of these more hopeless cases must receive preference for admission to our educational institutions in order that our future medical men may be trained. One may be blamed for giving vent to inhuman opinions by those who do not care to face hard facts, but is it not the responsibility of the public to provide accommodation for all, and is it not our duty to bring this home to the public in every possible way?

The Best Sites for Hospitals.

Where should our large hospitals be situated? They represent the hospitals at the bases in France and in England. Only aid-posts, dressing stations, and so-called clearing stations were situated near the fighting line. The same arrangement could be made for civil combatants, as we have been calling the workers for the nation. Large hospitals need not occupy valuable space in their fighting area. These hospitals are much better situated in the green fields and woods on the outskirts of towns. Dressing stations and casualty clearing stations could be established in the busiest quarters of the town to perform functions similar to those they performed for the army.

Some Surgical Lessons.

The foregoing are some thoughts pertaining to general professional matters. Regarding more purely surgical subjects which I may be expected to discuss I do not intend to say much. You may hear and see in the wards of most hospitals from time to time the practical applications of many of the war lessons to surgical operations on civil patients.

The cruel effects of modern high explosives and the accompanying conditions of modern warfare forced the acceptance of many principles which were considered to be new. It is but just to say, however, that most of these principles had been advocated for several years before the war by certain surgeons. I shall mention only a few examples.

1. The treatment of infected wounds by excision of infected and devitalized tissue. This could sometimes be followed by suture of the wound, and in the hands of the best operators healing by first intention was obtained in the majority of cases which were amenable to such treatment. This, when compared with the general methods applied at the beginning of the war, was an incomparable

boon to the patient in all sorts of ways. It was not new. This method of treatment had been carried out in soiled wounds of soft parts as well as in compound fractures—for example, by Macewen of Glasgow, and, independently, by myself—for many years before the war; but unfortunately it was only tardily accepted as a routine procedure in the theatres of war. The application of the principle to the treatment of wounds of widely varying types in the different regions of the body met with such marked success that the saving of life, limb, and function was incalculable. The treatment, as I have indicated, is equally applicable to recently inflicted and even grossly infected civil wounds.

2. Perhaps the most theatrical of all general advances was in the treatment of severe wounds of the chest. At first practically all cases of severe thoracic wounds died—namely, those in which parts of the chest wall were blown away. So far as I could ascertain, these severe types formed about one-third of all wounds of the thorax in patients who reached the casualty clearing station alive. In a year and a half at Rouen base, the centre of many groups of hospitals, I did not see more than half a score of such cases. In one month at the front, during a battle, there were about 500 cases admitted to the casualty clearing stations of the army to which I belonged! In the last year of the war the best surgeons were operating on them so successfully that they were sending approximately 70 per cent. down the line, with every prospect that the patients would become useful citizens again. The war success in thoracic surgery has stimulated surgeons all over the world to cope with cases in a region which was previously left severely alone, save when comparatively simple measures could be applied. Yet before the war isolated surgeons in different parts of the world were striving to perfect technique along lines which the experience and stimulus of the war have shown to be correct. In no other field of surgery has development been so striking and so widespread. Experience in the war has at the same time shown that elaborate apparatus in the performance of such operations is not essential for success.

3. The effect of proper treatment of severe fractures was almost as striking as that in injuries of the chest. Severe compound fracture of the femur was, at the beginning of the war, one of the most fatal injuries in patients who survived long enough to come under the care of the medical service. The disastrous results were due to the effects of shock, haemorrhage, and sepsis. The late results in a large number of cases did not redound to the credit of the profession, yet by well-thought-out preventive work and extreme care in operative and after treatment gradually the mortality was enormously reduced and men were turned out again to civil life with marvellously useful limbs. In this class of case the institution of special hospitals with specially selected surgeons and equipment had much to do with the improvement.

In connexion with this class of injury, I must mention Thomas's knee splint. I do not suppose that Thomas in his wildest dreams ever thought that his splint would lead to the saving of literally thousands of lives in such a short period. This splint and its modification for use in fractures of the upper extremity are so valuable, especially during transport, that I recommend every one of you to become thoroughly conversant with the best methods of applying them. Thomas's leg splint and the similar arm splint should form part of the armamentarium of every general practitioner and surgeon.

4. The methods of combating shock and the effects of haemorrhage rise to one's mind in connexion with fracture of the femur. The description of such methods as were used at the front and which are so easily adapted for use by the general practitioner and hospital surgeon makes interesting and useful reading. We have to thank our Canadian and American confrères that the therapeutic value of infusion of blood or its substitutes became evident to the profession as never before, and this method of treatment is applicable to so many conditions in civil life that you should lose no opportunity of seeing it carried out.

5. The treatment of septic arthritis which was introduced during the war by Wilms, a Belgian surgeon, showed that time-honoured customs in surgical treatment, as in education, are not inviolate. Wilms demonstrated that the only way to drain a joint adequately is to provide free exit by means of ample incision, and then, by making the

patient move the joint spontaneously and vigorously, to cause the effusion to be forced out. Passive movements do harm. Under this treatment many even severely affected joints have recovered with free movement. To encourage movement of any sort while inflammation is still present in a joint, or indeed in any part, is contrary to all previous teaching, yet the recommendation is justified by results, as I have been able to prove to my satisfaction on several occasions during the war and since my return to civil practice. I wish to point out that the same factor as is involved in the use of active movements in joint sepsis is revealed at work in cases which recover after operation for peritonitis or pleuritis. In these, normal movements of bowel or lung speedily occur, and, mark you, it is better to dispense with drainage. If, in peritonitis, the bowel is so badly affected that peristalsis is paralysed, or if, after operation for pleurisy, the lung does not expand, recovery is, to say the least, a doubtful issue, even when drainage is established. In some cases of peritonitis, when the bowel is paralysed, temporary drainage of the bowel to remove its poisonous contents may have to be carried out in preference to other treatment, owing to the precarious state of the patient, or in bad cases of empyema all that may be possible is simple drainage of the pleural cavity. It seems to me, however, that in all these types of cases we are gradually being forced to rely more on the natural powers of the patient than on any artificial aids we can give. The rôle of the surgeon in such cases is merely to remove obstacles to natural processes of cure and then to clasp his itching fingers. My war experience has augmented the conclusion to which I had previously arrived, that, generally speaking, the use of drains must be included in the category of meddling surgery, or, in other words, that the necessity for the use of a drain is evidence of imperfect work. The trouble is that none of us can be sure of doing absolutely perfect work. Human limitations and mechanical weakness demand the occasional use of drains. For example, drainage of dead spaces which cannot be obliterated and drainage of a gall bladder to prevent distension of a sutured common duct may be necessary for safety. We must remember that, in the former instance, drainage is for removal of nutritive fluid only—that the presence of the foreign body, the drain, be it ever so soft, favours the growth of organisms. The less expert the operator, the greater the necessity for drainage.

One wonders whether drainage of septic joints, after removal of the cause of the sepsis or of the obstacle to healing, is really necessary any more than in a case of peritonitis. One wonders how long it will be before ordinary acute peripheral abscesses will be freely opened, wiped out, and immediately closed again by well-judged suturing. For years past I have been performing "delayed primary suture" in such abscesses.

As Wilms has shown, and as I had previously experienced during several years before the war, absolute fixation after so-called aseptic operations on joints is really a bar to rapid restoration of function. Is not Wilms's principle apparent in rational after-treatment of all sorts of cases? Should we not always encourage patients voluntarily to exercise normal functions as soon as possible, instead of interfering with natural processes by coddling them too long in bed, by using massage or electrical stimulation and other artificial so-called helps, when really the patient can better help himself?

6 and 7. Two instances of development of work at home deserve, I think, special mention. One was the enormous strides made by many surgeons in orthopaedic surgery in its various branches—bone-grafting, nerve-suture, and so on—and in appreciation of other than purely operative measures in orthopaedic treatment. This was largely due to the strenuous work of Sir Robert Jones, with whom I had the honour of being intimately associated for a considerable time. Another instance was the organization of the treatment of amputation stumps. Some of you may know from bitter experience what a nuisance a stump may be in itself, and that an artificial limb must receive very skilled attention before it is really serviceable and comfortable. Special centres have been instituted in various parts of the country to provide such skill for numberless sufferers. Sir J. Lynn Thomas of Cardiff has estimated that before the war there were 40,000 persons in the country who had lost one or more limbs. Surely this surprising fact is enough to make us preserve

at least some of these centres where the skill acquired will be still available, and to which we may send civilian patients to be properly fitted with artificial limbs and to be trained in their use.

I have said enough. I am afraid that I have dealt with my subject in a somewhat crude and superficial manner, but I hope that the suggestions which I have expressed may stimulate you, who have to deal with future developments, to think seriously and broad-mindedly about these and kindred subjects and to take an active part in the solution of the problems which are entailed.

Observations

ON

SPLENIC ANAEMIA: BANTI'S DISEASE.

PART OF THE BRADSHAW LECTURE ON THE SURGERY
OF THE SPLEEN.

BY

SIR BERKELEY MOYNIHAN, K.C.M.G., C.B., M.S.

F.R.C.S.

SURGEON, LEEDS GENERAL INFIRMARY; PROFESSOR OF CLINICAL
SURGERY, UNIVERSITY OF LEEDS.

"BANTI'S DISEASE" is the name given to the condition described in 1883, and again in 1894, by Guido Banti of Florence. In 1866 Gretzel described a clinical condition of anaemia associated with splenomegaly to which Griessinger applied the name "splenic anaemia." The case occurred in a child 10 months old who suffered from dysentery and severe anaemia with considerable enlargement of the spleen, and enlargement, less considerable, of the liver and lymphatic glands. Examination of the blood showed that the proportion of white to red cells was not increased; the condition was therefore not leukaemia. In 1871 Wood described a "splenic form" of pseudoleukaemia, and reported a case in which the spleen was greatly enlarged, and there was severe anaemia without leucocytosis. Banti, in his later description mentioned above, considered the disease as possessing clinically three stages, merging gradually into each other. These stages were:

1. One in which there was enlargement of the spleen and a secondary anaemia, the duration being three to twelve years.
2. One in which the liver gradually enlarged, and the amount of urine underwent progressive diminution; the duration was brief.
3. One in which the liver gradually shrank in size and ascites appeared, the symptoms being those of an ordinary atrophic cirrhosis; the duration of this stage was between one and two years.

The disease was invariably fatal, and death occurred either from haemorrhage or from autointoxication from cirrhosis.

Clinical History.

Splenic anaemia was defined by Osler as "an intoxication of unknown nature characterized by great chronicity, primary progressive enlargement of the spleen which cannot be correlated with any known cause, anaemia of a secondary type, with leucopenia, a marked tendency to haemorrhage—particularly from the stomach—and in many cases a terminal stage with cirrhosis of the liver and jaundice." The clinical features of the disease, then, are the following:

1. A very chronic course, in which the symptoms progressively and steadily increase in severity, without amendment, and without any hope of spontaneous recovery.
2. A slowly progressive enlargement of the spleen. This is the first of all evidences of disease; the bulk of the organ undergoes an increase, at first apparently slight, but later more rapid. The ratio of increase probably remains unaltered throughout. The enlargement may finally be very considerable, though it is rare for the spleen to become as large as in myeloid leukaemia, or in some cases of Hodgkin's disease, or in malaria, or in Gaucher's disease. The spleen is not altered except in bulk, so far as physical examination shows; the surface is smooth, the notches apparent; there is no tenderness, nor is a friction rub felt or heard. It is said that a "bruit de diable" has been heard (Sippy, Rolleston) "due to eddies produced by slight torsion of the dilated veins in the gastro-splenic omentum or of the splenic vein." Seeing that clinical recognition of splenic enlargement is not possible until the

* Delivered before the Royal College of Surgeons of England on December 6th, 1920. The lecture is published in full in the *British Journal of Surgery*, January, 1921.

spleen is at least double the normal size, it is more than probable that the inaugural and early symptoms of splenic anaemia are quite unrecognized.

3. *Changes in the blood* are of the type found in secondary anaemia. The red cells may drop to less than 2,500,000 per cubic millimetre; the average number is one-half of the normal. The colour index is low. In a series of fifteen cases Osler found the number of red cells to be 3,425,000 per cubic millimetre and the haemoglobin 47 per cent. A recent haemorrhage will of course affect the count very considerably; though it has often been observed that recovery after a haemorrhage is rapid, and that within two or three weeks the blood count may so improve as almost to reach the normal. The white cells are never above the normal unless there has been a recent haemorrhage, or an inflammatory complication is developing. Leucopenia is the rule. In Osler's case the average count was 4,520.

4. *The tendency to haemorrhages* is remarkable. Haematemesis especially is seen, occasionally with copious melaena. Other forms of bleeding are also mentioned in recorded cases: epistaxis, purpura, and haematuria are the most commonly seen. The amount of blood lost, especially from the stomach, may be enormous. I have seen two cases in which the apparently pure blood vomited within a couple of hours measured over three pints. Osler records a case in which three quarts of blood were lost within thirty-six hours. Recurrence of the haemorrhage is frequent. A remarkable case is related by Hutchison and Ledingham of a woman who was admitted to the London Hospital on account of severe haematemesis no less than thirteen times within a period of fifteen years. The blood comes in such cases, it is believed, from oesophageal varices and dilated vasa brevia, both of which are found in a large proportion of the cases.

5. *Affection of the liver.* In the later stages of the disease the liver enlarges, and presents the clinical pictures of Laënnec's cirrhosis. Ascites is present with the hepatic enlargement, or in some cases without it. This terminal condition, in which the liver is enlarged and dropsy is present, together with the earlier conditions described, is often spoken of as "Banti's disease"; but if this latter term is retained it is perhaps wiser to use it only as a synonym of "splenic anaemia."

6. *An unknown causation.* The discovery of a cause for the splenic condition removes the case from the category of splenic anaemia. As I have said, the term "splenic anaemia," as originally used, included a group of diseases characterized by certain clinical features common to them all. Upon this group encroachments have steadily been made, and may well continue to be made, as our knowledge of the etiology of special diseases becomes by degrees more accurate.

7. *Other phenomena of less importance* may briefly be enumerated. A general enlargement of lymph glands is not present. Until the latest stage there is no alteration of the urinary function. Occasional attacks of heaviness in the epigastrium, flatulence, and indigestion are observed, which lead, when haemorrhage occurs, to a diagnosis of "gastric ulcer." Such dyspepsias are less frequently seen than might be supposed. Rarely there may be slight pigmentation of the skin. If jaundice is present, the case is not one of splenic anaemia.

Differential Diagnosis.

This, as a rule, is not difficult. The mistake I have most commonly seen is the making of a diagnosis of *gastric or duodenal ulcer*. I have now seen 5 cases in which a patient suffering from splenic anaemia was referred to me as an example of these diseases. The absence of a clear history of dyspepsia, the presence of an easily palpable spleen, and the blood changes, soon revealed the true condition. The contrary mistake may be made. Rolleston relates the following case:

"Some years ago a middle-aged man was under my care in St. George's Hospital. He was very anaemic, and with a history of recurrent haematemesis. There was a tumour which appeared to be an enlarged spleen, and the condition was regarded as splenic anaemia. The necropsy showed that the tumour was a large hydatid cyst in the left kidney, and that a chronic gastric ulcer was responsible for the repeated haematemesis."

In any doubtful case an x-ray examination would almost certainly clear away the uncertainty and demonstrate the presence of a chronic gastric ulcer.

Cirrhosis of the liver has occasionally presented difficulties in diagnosis. The number of cases in which the splenic enlargement is considerable, and the hepatic enlargement slight, must be excessively small. That the spleen may be much enlarged in cases of Laënnec's cirrhosis is certain; and in such a condition a copious haematemesis might well raise a doubt as to the true diagnosis. Nannyn and others consider that splenic anaemia is merely a type of hepatic cirrhosis in which the liver changes are relatively slight, at least until the final stages are approaching. If a patient is first seen when the spleen is grossly enlarged, the liver cirrhotic, ascites abundant, haemorrhages recurrent, and ill health and emaciation advanced, it is not certainly possible to say whether the case is one of advanced Laënnec's cirrhosis or is in the terminal stages of Banti's disease. The accurate diagnosis is, however, made without difficulty if the earlier stages of the disease are carefully sought.

Syphilitic enlargement of the spleen and liver may be associated with a moderate degree of anaemia. In such cases the

symptoms of splenic anaemia are reproduced with remarkable accuracy. The differential diagnosis is achieved by a close study of the history, by a discovery of a positive Wassermann reaction, and by a recognition of the effects of antisyphilitic treatment. The latter, however, is not always successful. W. J. Mayo records five cases in which he removed enlarged spleens in conditions of chronic intractable syphilis with severe anaemia, when the patient had been resistant to careful treatment for syphilis, carried out during a period of several months. After removal of the spleen the anaemia rapidly disappeared and the syphilis was cured with comparatively mild antiluetic treatment such as had previously failed to affect either the syphilitic condition or the spleen. Conland records a case in which the spleen was removed for "splenic anaemia" with much benefit; the patient died two years later, and syphilitic disease of the liver was found.

Pathogenesis of Banti's Disease.

The fact of utmost significance in connexion with the causation of this disease is that it is cured or arrested by removal of the spleen. This fact may be accounted for either by assuming that the disease is primarily and essentially located in the spleen, or by assigning to the organ the rôle of modifying the action of some agent situated elsewhere in the body. If the disease is primarily splenic, a search for a specific microbial infecting agent should ultimately be successful. Hitherto no convincing evidence of this has been found, although Hollins has argued strongly in favour of incriminating the colon bacillus. There is scope for further research in this direction; and the organ removed during life, if straightway examined, should provide profitable material for routine bacteriological investigation.

The enlargement of the spleen has been attributed to excessive haemolytic activity by those who consider the disease to begin in some other part of the body. But such a view does not sufficiently explain the fibrosis which is the outstanding histological feature of the disease. A chronic infective process would account for the enlargement as well as the fibrosis, and accord better with the absence of undue haemolysis of the red blood cells. In splenic anaemia the red cells never show "fragility." If there is a change the corpuscles may show increased rather than diminished resistance.

The anaemia, in like manner, may be regarded as an incident or as an essential part of the disease. Rolleston, a very distinguished authority, does not regard the anaemia as primary; he believes it to be secondary to attacks of very severe haemorrhage, chiefly because he finds that regeneration of blood takes place after these events. This view, however, is, I think, subject to the criticism that such severe haemorrhage is not invariable, and that the substance elaborated in the spleen need not be capable of affecting the bone marrow until after it has left the liver, where it has undergone modification. Further, whatever the poisonous substance may be, it need not completely arrest blood-cell development. A parallel case is, I think, sometimes furnished by subjects of leukaemia in which an intercurrent infection supervenes, with a temporary restoration of the normal blood picture.

Hollins regards the disease as being due to an active "intoxication" produced by the colon bacillus, whose "colylisin" brings about the anaemia, whilst its actual presence in both spleen and liver accounts for the fibrosis of each organ. This view would put every kind of cirrhosis of the liver on the same level, because "colylisins" could not be expected to vary radically in their action. The facts would be better met were it suggested that the spleen harbours various organisms, some of which only excite a local fibrosis, others induce a simple cirrhosis of the liver, and still others produce that form of cirrhosis associated with Banti's disease, with a toxic anaemia, and other specific symptoms.

In respect of the haemorrhage which is so conspicuous and alarming a feature of some cases, Rolleston considers that the enormously distended vasa brevia rupture into the stomach as a result of the torsion of the splenic vein caused by the great bulk of the organ. This opinion is certainly correct in many cases. The haemorrhage is so profuse, and so swiftly escapes from the stomach, that large vessels must be implicated. Such vessels as Rolleston describes are often seen in operations upon cases of splenic anaemia when abundant haematemesis has occurred. But this cannot, I think, be the whole explanation. The relationship between enlargement of the spleen and gastric haemorrhage is cryptic, but certain; for, as Balfour was the first to show, removal of the spleen may cure a patient

whose life has been jeopardized by severe and recurrent haemorrhages from the stomach. Gastric haemorrhage is known to be toxic in origin in certain cases, as, for example, those in which there is a lesion in the appendix, intestine, or gall bladder; and those also in which the lesion lies in the spleen or liver, or both.

Treatment.

The only treatment for splenic anaemia is splenectomy. The appropriate moment for the removal of the organ is chosen. It is inadvisable to operate soon after a grave haemorrhage, or when the spleen is extremely large. In the latter case, the effect of radium on the tumour should be tried; almost certainly it will cause a rapid and considerable shrinkage in the organ. If this should happily be the case, splenectomy is done when the spleen is at its smallest, and before it has begun to enlarge afresh, as it will certainly do after a few weeks. It is imperative to operate upon cases of this disease as early as possible. No other form of treatment needs consideration; the dangers and difficulties of the operation increase with the lapse of time; early operation means a more certain chance of recovery and a quicker convalescence. In the later stages the mortality of operation is higher, amounting to 25 per cent., as compared with an average of about 10 per cent. In the terminal stages operation becomes so dangerous that only the inevitably fatal outcome of the unhealed disease justifies its performance.

The degree of improvement that may take place is astonishing, even in the late stages of the disease, with advanced involvement of the liver. It is, as W. J. Mayo says, an evidence that the great power of the liver to regenerate its specific cells is utilized to the full.

The difficulties of the operation are greater in splenic anaemia than in any other disease. In almost all cases adhesions binding the organ especially to the under surface of the diaphragm are present. They may be numerous and exceedingly dense, and their separation may cause a copious and grave haemorrhage. But they are never so dense nor so strong as to prevent the completion of the operation. The details of the operation in other respects are the same here as elsewhere. At the Mayo clinic up to September 20th, 1920, 73 operations had been performed, with 9 deaths, equal to 12.3 per cent. The after-results are excellent; the rather high operative mortality is due to the technical difficulties of the late cases, which, apart from operation, would all be fatal.

ON THE END-RESULTS OF COLECTOMIES FOR INTESTINAL STASIS.*

BY

A. W. SHEEN, C.B.E., M.S., F.R.C.S.,

VISITING SURGEON, ORPINGTON AND SHEPHERD'S BUSH HOSPITALS,
MINISTRY OF PENSIONS; CONSULTING SURGEON,
KING EDWARD VII'S HOSPITAL, CARDIFF.

I propose to give here the results of complete colectomies performed in the years 1913-14. The war necessitated for me, as for many of us, a beneficial patience, in that "cures" were not too easily claimed by too immediate publication, and the term "end-results," tautological, but well understood, will be, I think, here justified.

The cases are only four in number, and one of them died soon after the operation. No excuse is necessary for bringing to notice such a small number, for it is of the small numbers, even of the solitary cases, that the profession desires, and ought to know. If the very wide usefulness claimed for this operation is justified, it ought to be very widely practised; the reasons for its necessity, its results, immediate and remote, and its mortality cannot be too well known.

I had long been interested in the work of Sir Arbuthnot Lane, and having, through his kindness, seen several of his cases and both watched and assisted at the operation of colectomy, I operated on these cases, which were selected as being advanced in type. The details and immediate results are recorded in the BRITISH MEDICAL JOURNAL of 1914; and these I will not now repeat. The "end-results" of the three cases are as follows:

CASE I.

W. C., male, aged 30 at time of operation on November 6th, 1913. I saw him on March 3rd, 1920, six years and three months after the operation. Back at full work as a bricklayer; feels a different man to what he felt before the operation; is no fatter. Quite all right until six months ago, since when he has had occasional abdominal pain, sickness, and diarrhoea. He is a healthy-looking man, with none of the stigmata of stasis. There is a large divarication of the recti, for which he wears a useless flannel binder. I wrote to his doctor, recommending a truss belt and attention to the teeth. I heard from the patient on August 5th that he felt very much better now that he had the new belt, that his teeth had been extracted, and he hoped to have the new set shortly.

CASE II.

A. M. S., female, married, two children, aged 34 at time of operation on March 2nd, 1914. I saw her on April 20th, 1920, six years and two months after the operation. She has got much fatter since the operation, takes food all right, and feels a different woman. Her friends have noticed that she has "cleared wonderfully." She has had two more children since, one now aged 4 and the other 2 years. All right until a few months ago, when she began to have lower abdominal pain and was constipated, her bowels sometimes not acting for a week. Her menstrual history was that her periods had always been profuse and frequent, that from January 14th to March 13th, 1920, there was no period, and she thought she was pregnant; on the latter date she had "flooding," and then a period on April 5th. She is a well-nourished, healthy-looking woman. The abdominal wound is soundly healed and she wears no support. The lower abdominal swelling and tenderness I found on vaginal examination to be associated with an enlarged uterus. I sent her on the same day to Dr. Ewen Maclean, who kindly saw her at once and pronounced her three and a half months pregnant, the fundus of the uterus being inclined backwards and to the right, possibly from parietal adhesions. He considered the symptoms and physical signs notwithstanding—that miscarriage was not inevitable; also that parietal adhesions were not incompatible with the birth of two children subsequent to the operation. I heard from her on August 6th that the pregnancy was progressing naturally, and recently her doctor, Dr. McMichael of Vowchurch, Hereford, has written to me to say that she was confined on September 29th last and is going on well.

CASE III.

C. W., female, married, five children, aged 44 at the time of operation on April 30th, 1914. I was not able to see her myself, but Dr. T. E. Lloyd of Abergavenny kindly wrote as follows under date March 7th, 1920, five years and ten months after the operation: "Mrs. W. showed me your letter and I promised to write to you on her behalf. She is quite a different person, stout and well, with the exception of occasional attacks of diarrhoea, which I believe are neurotic. She used to be more or less constantly on one's list, but I hardly ever see her professionally now." I can supplement this from my note when I saw her five months after the operation, which says that she had then put on a stone in weight, her friends say she looks quite different, she is better than she has been for years, fat, healthy-looking, with a clear complexion; strong abdominal scar. She herself wrote on August 14th, 1920, saying that previous to the operation she had been under medical treatment for years, that since she has had excellent health and feels quite a new woman, that her people think she is a miracle and that she has got stout, her present weight being nearly 11 st.

What, then, are the end-results in these three cases? In all great improvement, which in the last two might be termed complete success. The qualifying details are: In the first case a ventral hernia with dyspeptic symptoms; in the second, adhesions, fortunately not interfering with pregnancy; in the third, diarrhoea occasionally. It is also to be remembered that a fourth case died after the operation.

There is an operative parietal infection in these and similar cases, which is, I think, too lightly regarded, being not referred to or just mentioned in the recording of operation results. As the aseptic precautions taken by operators are modern, minute, and successful under other circumstances, it is justifiable to regard this infection as coming from within. Gross infection from cut bowel ends should be avoidable, and the only explanations which suggest themselves are either that in toxic people there are micro-organisms in the peritoneal cavity which it can put up with, but the parietes cannot; or, that micro-organisms in the depths of the parietes are stirred into activity by the injury inflicted. Possibly the poorly vitalized parietes cannot deal with the few external micro-organisms which probably always remain in the skin and in its ducts, but this I regard as unlikely. The usual germ in the infection is *B. coli*. It may be that cultivations have been taken from peritoneal cavity or from cut parietes at the commencement of an operation: I do not know that this has been done, but it would be useful. That parietal infection is a

* A paper read to the Cardiff Medical Society, November 9th, 1920.

very real and not infrequent complication, I have not a doubt. It gives the surgeon a troublesome and anxious time after operations. That it has troubled Sir Arbutnot Lane I recognize by his dressing of sterilized hot boracic fomentations, changed hourly after operation. I read of other operators having the same trouble, for instance, Mr. Waugh in his colopexies for stasis, to which operation I shall refer later. A ventral hernia, as in my first case, is not a satisfactory thing. It causes discomfort, dyspepsia, and inability to carry out fully the normal occupations. It requires a truss belt or a secondary operation with possibly the introduction of a filigree; this cannot be regarded as a satisfactory "end-result."

Internal adhesions may come from peritoneal disturbance, bringing into activity latent infection, or as a spread from parietal infection. Pain, flatulence, constipation, or diarrhoea may result from them; they are obviously undesirable, and are exemplified as possibly, but not actually, affecting pregnancy in my second case. The occasional diarrhoea of my third case Dr. Lloyd charitably regards as neurotic, but I assume it to be due simply to the removal of the colon.

There remains the fact of the death in my fourth case. As a necropsy was not allowed I can only testify to a hasty investigation through the operation wound, showing thin odourless pus in the pelvis and lower abdomen, nothing else. The strength and general condition of this patient (a female), the technique, the operation environment, and the after-treatment were similar to those in the cases which recovered.

There are ways which have been and are being evolved for preventing infection and adhesions. These I need not detail; but, whatever is done, the fact will always remain that the risks of those undesirable sequelae will always be greater in this class of case than in other classes of abdominal operations, the risk being greater the greater the "germ-soaked" condition of the patient. Their importance and frequency in preventing complete success can only be estimated by a careful consideration of all "end-results."

In spite of the good results in these three cases I confess that I am not enamoured of this operation. I cannot enter into the immediate dangers which exist, but the operation is undoubtedly a serious one. Is there anything which can take its place? I accept the toxæmia, its signs and symptoms, and that it is due to a blocking of the "ileal effluent" owing to displacements, kinks and adhesions of caecum and colon, these again resulting from upright posture, habitual constipation, and, I would add, tight clothing in women. The germ invasion with the absorption takes place in the ileum; the colon is the mechanical factor. Symptoms vary in degree and severity according to the amount of the delay and the intensity of the infection, the latter sometimes, but not always, depending upon the former. The surgical "purists," if I may call them so, say that there are only two lines of treatment, paraffin and a truss belt for the slighter cases and those which, for one reason or another, are not operated on; colectomy for the rest.

We are all acquainted with the long list of maladies which it is suggested by Lane may have their origin in stasis. A degree of absorption with its resulting ill effects may be conceived as the unhappy possession of most of us. It may be that a sterile ileum, if ever obtained, will help to confer immortality! The trained and, let us hope, unprejudiced eye of the advanced advocate of the toxic doctrine will diagnose many cases even among children, as "toxic," and will advise, at the least, belt and paraffin for those who have compassed 50 years or more of life's span.

Is there nothing besides the belt and paraffin but complete colectomy? Colectomy has been before the profession for many years, and has been most ably advocated, yet I am convinced that it is not a popular operation amongst surgeons. Go to any of our large hospitals and find out how many complete colectomies for stasis are done in a year. I think that there are very few. The operation is serious, and I question whether it will become less so, at all events in the hands of the general body of the surgical profession, by whom, if its wide applicability is accepted, it should be largely practised. The mortality is not easy to ascertain. Many cases recover and are greatly benefited; some cases die. But there is a third class in which there is

neither death nor recovery, but an almost hopeless discomfort nearly as bad as that which existed before the operation. Clark² records the "final results" in twelve cases; in six of these it was not satisfactory.

Are there other alternatives? Ileo-colostomy has proved surgically unsatisfactory because of the dead "bag" of colon left. I do not venture to discuss the medical treatment except to remind you of aperients. Nowadays, the cynic says, men look not for light and leading but for laxatives. In the lowest grade of treatment, the patent pill or potion, it is aloes, aloes all the way. Pick up a weekly newspaper in some country district and you will see among the advertisements therein the photograph of a female who beneath it describes, in simple but graphic language, all the symptoms of stasis, and all completely removed by so many boxes of somebody's pills.

Abdominal operations of various kinds are done and toxæmia previously present disappears. We shall be told of all such operations that they have produced their good results by freeing of the ileal effluent, that—for example—merit unexpected has been acquired by the removal of a "controlling appendix." Granted, but is not the lesson to pursue where possible a less dangerous and less drastic method than complete colectomy?

It may apparently not even be necessary to open the abdomen. I quote³ the following as to the operation of nephropexy: "I have visited these patients and observed the wonderful change in their appearance after a few days. The complexion becomes clearer and pigmentation around the eyes almost disappears and their friends are astonished at the improvement. . . . I have asked the patients to see me from time to time till they have completely recovered. One cannot get over facts. It is not a question of half a dozen cases but of hundreds."

A recent paper by Mr. G. E. Waugh,⁴ with which I am much more in sympathy, attributes the impairment of mechanical efficiency of the bowel with the resulting manifold evidences of tissue degeneration similar to those for which colectomy is advocated to an ascending colon which has retained and perhaps elongated its primitive mesentery; this developmental survival is present in 20 per cent. of individuals born. The symptoms manifest themselves in early adult life, and the drag affects not only the colon but also the right kidney, the stomach, the duodenum, and the gall bladder. An easy, safe operation—fixation of the ascending colon—cures, and symptoms of stasis disappear. Doubtless, again, especially as the appendix is removed, a freeing of the ileal effluent; but, if Mr. Waugh's contentions are correct, what a much safer way of freeing it than by colectomy! I am attracted by this operation and have carried it out recently in several cases, in all of which there has been immediate improvement.

It must be a commonplace with those, like myself, who have had a surgical experience of the abdomen extending over many years that various operative measures have seemed to cure patients clinically who, *inter alia*, had signs and symptoms of toxic stasis. As long ago as 1909 I read a paper to the Newport Medical Society⁵ on the treatment of abdominal displacements, and from my then experience I concluded that every case should be treated on its merits. From this conclusion I see no reason to depart. I can recall cases of operations on gall bladder, stomach, and appendix; of fixation of liver, of stomach, of colon; of the freeing of adhesions in various quarters; of other operations. In all there was more or less evidence of stasis, yet in all alleviation or cure resulted. I may relate a recent case as an example:

A young lady, aged 25, had moderate toxæmia, pain, that constipation with spurious diarrhoea which is so common, a dropped transverse colon as shown by a bismuth meal, debility, and loss of flesh. A scar with pain and tenderness represented a mysterious operation said to have been for mtnsusception when she was 6 years old, when tuberculous disease was found and the abdomen closed hurriedly. I operated, and a long incision revealed adhesions of large and small intestines to one another, and to the old parietal scar; adhesions between intestine and the left uterine appendages; a moderately dropped transverse colon and a diseased appendix; nothing else; no tubercle. The adhesions were divided, the appendix removed, and the transverse colon slung high up transversely to the abdominal wall. I have seen this lady quite recently, and she is wonderfully well, putting on weight, strong and active, bowels acting regularly without aperients. Since operation she has worn a truss belt. It is too early yet (five months) to give the end-result, but so far it seems to be "a cure."

Cases such as this may be taken to justify my contention that there are more surgical ways than one of curing toxic stasis, and that every case should be treated in accordance with the special indications it presents.

Neither, although I have been speaking as a surgeon, am I advocating surgery as the only remedy. Diet, drugs, aperients, paraffin, massage, exercises, posture, abdominal supports, regulation of life, change of climate, spa treatment, removal of toxic foci—all have their place in the treatment of intestinal stasis. In treatment, operative and non-operative, the psychic factor must not be overlooked. The rest and careful after-treatment is of benefit after all abdominal operations. The prevention of stasis and toxic foci should begin in babyhood and continue. The earlier the treatment the better, and then the less severe and the more effective it is. Prevention is indeed our final goal. Man steers his life's perilous course through the physical evils which beset him, and our hope for the future is that for the prevention of these evils we shall all work and strive so that stasis and its manifold ill effects may from being a problem of the present become a memory of the past.

REFERENCES.

¹ Sheen: Colectomy for Intestinal Stasis, *BRITISH MEDICAL JOURNAL*, December 26th, 1914. ² *Surgery, Gynecology, and Obstetrics*, 1916, vol. i, p. 533. ³ C. W. Suckling: *Twenty Years' Work on Nephrotosis*, Monograph, December, 1913. ⁴ G. E. Waugh: The Morbid Consequences of a Mobile Ascending Colon, with a Record of 179 Operations, *British Journal of Surgery*, 1920, vol. vii, No. 27. ⁵ A. W. Sheen: Some Considerations of the Treatment of Displacements of the Abdominal Organs, *Clinical Journal*, February 10th, 1909.

A CASE OF DIBOTHRIOCEPHALUS LATUS INFECTION.

BY

GEORGE C. LOW, M.A., M.D., C.M., M.R.C.P.

SENIOR PHYSICIAN, HOSPITAL FOR TROPICAL DISEASES, ENDSLEIGH GARDENS, AND SEAMEN'S HOSPITAL, ROYAL ALBERT DOCK; LECTURER AND CONSULTING PATHOLOGIST TO THE LONDON SCHOOL OF TROPICAL MEDICINE;

AND

ELIZABETH J. O'DRISCOLL, M.B., D.P.H., D.T.M., HOUSE-PHYSICIAN, HOSPITAL FOR TROPICAL DISEASES, ENDSLEIGH GARDENS, N.W.

Cases of infection with the broad tapeworm (*Dibothriocephalus latus*) are rarely seen in England. The infection is common in the Baltic provinces of Russia, in Finland, Sweden, Denmark, and Switzerland, and the presence of the parasite in many cases produces a severe form of anaemia, in some ways resembling pernicious anaemia. This is supposed to be produced by the excretion of a toxin. The tapeworm is contracted by eating raw fish in which the plerocercoid stage of the parasite is found.

The following case is interesting for two reasons—first, because there was no anaemia; and secondly, because of the successful expulsion of the worm by treatment. The patient, a Finn, evidently acquired the infection in his native country. He came to England in the course of his vocation, a seaman, and was admitted to the Seamen's Hospital, Greenwich, complaining of pains in the abdomen of an obscure nature. In addition there was a history of his having passed some segments of a worm in his stools. He was transferred to the Hospital for Tropical Diseases, Endsleigh Gardens, for observation and treatment.

H. K., a seaman, aged 18, born in Finland, was admitted to hospital with a complaint of abdominal pains. As the patient could not speak English, little history was obtainable from him.

Examination.—Healthy looking boy, no sign of anaemia present; well nourished, no emaciation. Cheeks a good colour; conjunctiva, no anaemia; teeth good. Systems: Heart and lungs perfectly normal, no sign of any disease. Abdomen, nothing palpable, no pain on deep pressure. Liver and spleen not enlarged. Urine: No albumin, blood, or sugar. Faeces: Many ova of *Dibothriocephalus latus* present; no segments passed while under observation.

Blood count:

Red corpuscles 5,100,000
White corpuscles 8,600
Haemoglobin 90 per cent.

Differential count:

Polymorphonuclears 55 per cent.
Large mononuclears 5 "
Lymphocytes 34 "
Eosinophiles 2 "
Transitionals 3 "
Mast cells 1 "

Treatment.

After being kept under observation for some time, during which he appeared normal in every way, eating and sleeping well, the following treatment was adopted.

After a very thorough starvation for two days, and a saline purge on the evening of the second day, liquid extract of filix mas was administered on the third morning as follows: A capsule of 20 minims at 8 a.m., a second of the same dose at 8.30 a.m., and a third at 9 a.m.—that is, 60 minims in all. A saline purge (magnesium sulphate) was administered at 12 noon. Apart from a slight tendency to sickness there was no trouble with the drug. At 4.30 p.m. the whole worm was passed, including the head. There was no sign of any second worm, this being confirmed by the disappearance of ova in the stools on subsequent days.

It is quite possible that the patient had only had the worm for a short time, and if this were so, it might account for the absence of anaemia. The worm, on the other hand, was a very large one and fully developed in every way. Another interesting feature in the blood examination was the absence of eosinophilia. The question of blood destruction, in helminthic infections generally, is a very interesting one, and more work might profitably be done upon it. The ordinary tapeworms, *T. saginata* and *T. solium*, do not appear to upset the blood picture in any way, and even with the *D. latus* a personal susceptibility may be required before the severe types of anaemia described appear. The lad was discharged from the hospital cured.

THE ECONOMIC ASPECT IN EYE INJURIES:

A PLEA FOR EARLY TREATMENT.*

BY

T. LISTER LLEWELLYN, M.D.

This paper is based on an analysis of the total accident claims made on the North Staffordshire coal and iron owners during the past two years. Cases in which incapacity lasted less than four weeks have not been included, nor have several cases of injury to the eye followed by the onset of miner's nystagmus, either immediately or within four weeks. Cases arising in previous years and settled during this period have also not been included.

TABLE I.

	Total.	Mines.	Iron and Steel.
No. of workmen... ..	45,000	35,000	10,000
No. of admitted claims (all accidents)	3,283	2,761	522
No. of cases of injury to the eye...	163 [†]	126	37
Total cost	£8,286		

* This figure (5 per cent.) agrees closely with those given by Collis in his paper on "Eye Diseases caused by Occupation," *Ophthalmoscope*, vol. xiii, p. 492.

The 163 cases may be divided into four groups:

1. Cases returning to work.
2. Cases of serious injury necessitating immediate expert treatment at the infirmary.
3. Cases in which a comparatively trivial injury is followed by nystagmus.
4. Cases in which a slight injury, either through neglect by the patient or lack of expert treatment, is followed by serious and permanent injury to the eye. Five of these cases developed a severe attack of nystagmus.

Even in the first group lack of proper treatment delays the return to work:

F. W. Blow in eye January 3rd. On January 16th there were still two pieces of coal embedded in the cornea. Played six weeks.

J. B. Blow in eye June 3rd. Foreign body in cornea on June 18th. Played five weeks.

J. H. Struck by iron stone January 31st. On February 4th there was marked injection of eye with a foreign body in the cornea. Played five weeks.

[†] Read before the Staffordshire Branch of the British Medical Association on November 25th, 1920.

These cases were sent on to the infirmary for treatment. It is probable that if the foreign bodies had been removed at the time of the accident there would have been little loss of time.

In the second group the original injury has either damaged the eye beyond recall or the patient is receiving the best treatment available. In the third group it is possible that early treatment might prevent the onset of the disease, as symptoms are often delayed. It is important to remember that there is a history of accident to the eye in 10 per cent. of all cases of nystagmus.¹

I wish chiefly to emphasize the importance of the fourth group. In these cases neglect by the patient, lack of proper directions, failure by the medical attendant to remove a foreign body or appreciate the presence of infection, may lead to results which can only be described as disastrous. On many occasions I have seen foreign bodies left in the cornea seven to ten days and septic ulcers of the cornea with hypopyon treated with boric lotion. I have often sent such cases, presenting themselves for examination under the Workmen's Compensation Act, for immediate expert treatment to the local institutions.

D. B. Foreign body in cornea one month after accident. Played seven weeks.

C. B. Struck with wire May 18th; seen May 31st. Marked injection of eye, corneal wound, shallow anterior chamber, opacity of lens. Treated with boric lotion. Sent to infirmary; admitted and iridectomy performed. Still playing five months afterwards.

J. D. Struck by coal. Attended infirmary seven days after accident. Septic ulcer leading to rupture of globe. Eye removed. Nystagmus developed afterwards.

J. L. Struck by coal June 23th. Septic ulcer and iritis developed before treatment at infirmary. Eye removed August 20th to prevent sympathetic ophthalmia. Vision in remaining eye good.

J. B. Struck by coal May 18th. On May 31st septic corneal wound with iritis. Treated with boric lotion. Sent to infirmary and admitted at once.

A. K. Septic ulcer of cornea with complete loss of sight from scar formation.

J. G. Extensive corneal opacity after septic ulcer. Nystagmus developed.

E. D. Corneal wound March 31st. Returned to work July 5th. Failed after five turns from onset of nystagmus. No symptoms before accident.

C. M. Blow in eye March 26th. Septic ulcer developed. Admitted to infirmary April 30th. Eye removed May 3rd. Well marked nystagmus September 3rd.

TABLE II.—Nature of Injury (16) Cases.

Burns of conjunctiva, injuries of eyelids	11
Contusions of globe	2
Conjunctivitis due to dust and injury	7
Injury to cornea:					
Slight	85
Severe	10
Septic ulcer	33
Penetrating wounds of eye	15

In 44 cases there was complete loss of sight in the affected eye:

Eye lost	17
Cornea opaque	17
Cataract	10

TABLE III.—Septic Ulcer of Cornea (3) Cases.

Complete loss of sight in affected eye	15
Eye lost	6
Severe attack of nystagmus followed in	5

The eye was lost in 11 of the 15 cases of penetrating wound of the eye.

TABLE IV.—Condition of Cases at end of Period in Review.

	No.	Total Cost.	Duration of Incapacity in Weeks.
Cases terminating naturally	79	£ 1,215	8.3
Cases terminating by commutation	19	4,697	13.0
Cases unsettled	65	2,373	36.7

In the 98 cases settled naturally or by commutation the period of incapacity was:

Between 4 and 6 weeks	40
Between 6 and 10 "	28
Between 10 and 20 "	15
Between 20 and 30 "	3
Over 30 weeks	7

TABLE V.—Unsettled Cases (67).

Receiving full compensation	35
Receiving half difference	11
Receiving no pay	19

PREVENTIVE MEASURES.

In occupations where there is special danger of injury to the eye goggles should be worn. Collis (quoted above) states: "Goggles have saved hundreds of eyes; thousands have been lost for want of them." Workmen should be warned of the danger of neglecting eye injuries, and should be encouraged to report at once at the first aid room. The first aid room should contain in addition to the usual outfit:

- One Winchester quart of boric lotion.
- One Winchester quart of sodium bicarbonate solution (gr. xv to the ounce) for acid burns.
- Castor oil (two ounces).
- Camel-hair brushes (two).
- Undine eye-washer.

The cost of this outfit is 8s.

The following instructions to the first aid attendant should be posted up in each first aid room (poster foolscap size):

INJURIES TO THE EYE.

INSTRUCTIONS TO FIRST AID ROOM ATTENDANTS.

To Wash Out an Eye.

Use warm boric lotion and the eye-washer.

To Remove a Foreign Body.

The foreign body may be under the lids or embedded in the eye.

- If embedded in the eye
 - Do not attempt to remove it.
 - Wash out the eye.
 - Drop in some castor oil.
 - Cover the eye with a bandage.
- If under lower lid
 - Pull down lid and wash out the eye. Use a camel hair brush if necessary.
- If under upper lid
 - Push the lower lid under the upper lid, and ask patient first to close and then to open his eye. Repeat the process. If this is unsuccessful, evert the upper lid as follows:

Seat patient on a chair and stand behind him. Lay a wooden match half an inch above the eyelashes. Press the match backwards and pull the eyelashes over it.

The foreign body will then be seen, and may be removed by washing or the use of the camel-hair brush.

After removal of the foreign body, drop in some castor oil and cover the eye.

After removal of the foreign body, drop in some castor oil and cover the eye.

After removal of the foreign body, drop in some castor oil and cover the eye.

Lime Burns.

Remove particles with wool soaked in castor oil. Wash out the eye. Drop in some castor oil.

Advise all men to see their Doctor at once.

A supply of printed slips giving directions to the workmen should be available. These slips should be handed to the workman when he reports his accident. The instructions should also be posted at the pit head or at the usual notice board in poster size. The slips are four by five and a half inches and the posters of foolscap size. The subject matter given below is the same in each case.

INSTRUCTIONS TO WORKMEN.

INJURIES TO THE EYE.

Report at first aid room and **Advise your Doctor** of all injuries to the eye.

Do not try to remove any particle which cannot be easily washed away.

Do not rub the eye.

If eye is painful drop in some castor oil.

Cover eye with clean bandage.

LIME BURNS: Go to first aid room. Wash out the eye and afterwards drop in some castor oil.

A neglected eye injury may lead to blindness. Go to your Doctor.

Under no circumstances should a solution of cocaine be part of the equipment of a first aid room as the feeling of comfort following the use of the drops will put off or delay the visit to the doctor.

TREATMENT.

I do not propose to enter into the question of treatment, but wish to confine myself to urging the necessity for the greatest care in all cases of injury to the cornea. The

treatment of eye injury belongs to a highly specialized branch of surgery, and should not be undertaken in a light-hearted manner by the general practitioner. If the doctor is in any doubt he should not hesitate to obtain expert advice. In his evidence before the Workmen's Compensation Committee Mr. Pooley (Q. 19,787) states that in Belgium special hospitals or wards, subsidized by the State, undertake the treatment of eye injuries for small fees. In this country the general opinion is against State interference, but both employee and employer have the right to demand adequate medical attendance.

SUMMARY.

What is the position of the workman and employer at the end of the period under review?

Workmen.—Forty-four men have lost the use of one eye and nineteen have developed nystagmus.

Settled for lump sum	19
Working full time	98
On half difference	11
Playing	35
Time lost at five turns a week =	17,250 shifts.

Employer:

Loss of output corresponding to time lost by workmen.
Expenditure in compensation, £8,286.
Liability of 68 unsettled cases.

It is the custom of employers to reserve a lump sum for unsettled cases. In the Yorkshire coal field one mutual indemnity society has reserved nearly three-quarters of a million pounds for all unsettled cases (Gillhespy, Q. 5731, Workmen's Compensation Committee). The money thus put by is not available for the purpose of expansion of work, and is a very considerable drain on small employers.

REFERENCE.

¹ T. Lister Llewellyn, *Journal of State Medicine*, August, 1920, p. 238.

THE DROOPING SHOULDER SIGN OF PHTHISIS.

BY

W. C. RIVERS, M.R.C.S., D.P.H.,

TUBERCULOSIS OFFICER, BARNSLEY DISTRICT, WEST RIDING, YORKS.

OF the last 50 consumptive cases (to go no further back) sent me for diagnosis, in just half there has been present a physical sign not mentioned in any British textbook. On the affected side, or (generally) the side of more extensive or older disease, the point of the shoulder and the nipple are lower than on the other side; the nipple is also smaller and seems to lie further back. Behind, the scapula is lower—its inferior angle may reach 3 in. below that of its fellow—and is at a different distance from the spine, mostly nearer to it. Muscular atrophy also is noticeable, a little of the pectorals, but far more of the upper part of the trapezius. The superior border of that muscle, instead of running straight from neck to shoulder, is flattened, wasted, hollowed out, so that, as compared with the opposite side, much less of it shows above the clavicle when viewed from the front, and above the spine of the scapula when viewed from behind. The sign occurs indifferently in men and women, although more marked in the former; and as regards association with the type of phthisis, in this order of descending frequency—juvenile hilus cases, a rather large proportion; third stage cases (Turban-Gerhardt), very nearly half; first stage cases, nearly half; second stage cases, about a quarter. I have seen it develop in the course of a few weeks. Photographs may be seen in a book of mine.¹

The above is the sign in full force. Krönig² says that in early tuberculosis of one apex the scapula of that side may be further from the spine, and often lower, than its fellow; in respiration its movement may lag; while in males and nulliparous females the corresponding nipple has likewise a lower level. The textbooks of Schröder³ and of Bancelier⁴ cite different authors who have noticed atrophy of the shoulder muscles on the affected side, while the latter mentions Aufrecht's observation, that on the side of disease the acromial end of the clavicle, mostly higher than the sternal one, may dip below it.

As to causation, the sign is pretty certainly tuberculo-toxic in origin; a somewhat similar asymmetry described

in lunatics is unaccompanied by muscular atrophy. The characteristic unilateral trapezius atrophy suggests that the weakening of this muscle in its upper part causes the corresponding half of the shoulder girdle to sag with the weight of the arm. The natural muscular inferiority of the left side has nothing to do with it, for the right trapezius is oftener affected than the left, agreeably with the fact that the right lung is more frequently tuberculous. I have seen a case, too, where the trapezius on the healthy side was much bigger, although scarred by a penetrating gunshot wound. Pottenger,⁵ like Fischer, describes spasm of the muscles overlying a tuberculous apex, ascribing it to reflex irritation reaching the muscle from the chronically inflamed lung by nervous paths (sympathetic to the cord and thence motor). The spasm goes on to pulpy degeneration. He does not mention atrophy, which seems to me far commoner than either spasm or pulpiness. Probably the spasm quickly goes on to atrophy. In bone and joint tuberculosis muscular spasm and atrophy are very common phenomena.

Lastly, the sign has great practical value. It is clear, objective, definite. It has commended itself to the general practitioners of my district, and to a Pensions Board. In children's phthisis, in chronic bronchitis complicated by a little patch of tubercle, it comes like a beacon.

REFERENCES.

¹ *Three Clinical Studies in Tuberculous Predisposition*. London, Allen and Unwin, 1917. ² Krönig: *Die deutsche Klinik am Eingange des Twanzigsten Jahrhunderts*, 1907, p. 653. ³ Schröder and Blumenfeld: *Handbuch der Therapie der Chronischen Lungenschwindsucht*, 1904, p. 88. ⁴ Bancelier and Roepke: *A Clinical System of Tuberculosis*, Hunt's translation, 1913, p. 42. ⁵ Pottenger: *Beiträge zur Klinik der Tuberkulose*, Bd. 22, H. 1.

Memoranda:

MEDICAL, SURGICAL, OBSTETRICAL.

OPHTHALMOSCOPIC APPEARANCES IN CERTAIN RARE CASES OF DIABETES.

THE ophthalmoscopic appearances in diabetes mellitus do not usually present any characteristic changes; in a few cases diabetic retinitis is detected (7 per cent. in a consecutive series of my own cases); but in certain very rare instances, associated with a special blood condition, a striking change is seen. The retinal blood vessels, instead of having the normal deep red colour, all appear milky white or pinkish white, whilst the rest of the fundus has the normal red colour.

To the naked eye the blood in diabetes does not usually present any striking alteration in appearance, but in a few very rare cases the blood is light pink in appearance. It has the colour of blood-stained pus, and is thicker than normal blood, being in appearance somewhat similar to anchovy sauce, but with a brighter tint. In some of these cases the ophthalmoscopic changes in the retinal vessels just described have been detected. It has been stated that chemical examination has shown that the fat in the blood has been increased in these cases, and the condition has been described as "lipaemia."

I do not know by whom the ophthalmoscopic changes were first described. I read of them ten years ago, and a small number of cases are on record; but as the condition is not well known, the following brief note may be of interest to those who are devoting attention to ophthalmoscopic examinations in medicine:

A man, aged 22, was sent to me for consultation by Dr. H. Ramsden of Debercross, on account of severe diabetes mellitus. Sugar had been detected in the urine six months previously. Thirst and diuresis had been prominent symptoms, and he had suffered from a carbuncle on the neck. In the routine examination of the blood I was surprised to find that it had not the ordinary deep red colour, but was light pink in colour and very thick. It had the appearance of blood-stained pus, or of anchovy sauce, but with a brighter tint. I examined the eyes with the ophthalmoscope and detected what I expected—the peculiar changes in the appearance of the retinal vessels of which I had read many years ago. All the retinal blood vessels and branches thereof were white; the retinal veins were cream white, the retinal arteries were cream white with a slight pinkish tinge. The optic discs were normal. The rest of the fundus had the normal red colour. Vision: R. $\frac{6}{6}$; L. $\frac{6}{6}$. This ophthalmoscopic appearance is probably characteristic of the blood condition just described.

I fixed an appointment for a further blood examination, but the patient was too ill to keep the appointment. It

was not therefore proved that the peculiar appearance of the blood in this case was due to "lipaemia." Moreover, the older methods of estimation of fat and allied substances in the blood have been criticized by modern physiological chemists. But the striking ophthalmoscopic changes and the marked alteration in the appearance of the blood were changes which could be recognized by the naked eye without other methods of examination. The ophthalmoscopic appearances just described are, therefore, those found in certain rare cases of severe diabetes, in which the blood has been very pale and thick, like blood-stained pns; such blood condition in cases previously recorded having been attributed, rightly or wrongly, to lipaemia.

Manchester, R. T. WILLIAMSON, M.D., F.R.C.P.

SEVERE TETANUS SUCCESSFULLY TREATED BY LARGE DOSES OF ANTITETANIC SERUM.

THE case of tetanus which I report below is of interest because of the short incubation period, and because a cure was effected by the use of antitetanic serum, high doses of which were given without any apparent ill effect to the patient.

A boy, aged 9, fell and received an abrasion, about half an inch in diameter, of the skin of the right knee. This became septic, and four days later he complained of what appeared to be toothache, accompanied by stiffness of the jaws. On the seventh day after the accident the father, who had been a soldier, suspected tetanus and brought the child to hospital.

On admission he complained of pain in the back, stiffness of the jaws, and pain and difficulty on swallowing. Temperature 98, pulse 120, respirations 30. He lay in bed on his back with rigid neck muscles, slight head retraction, and typical "risus sardonius"; he could barely force the tip of his little finger between his teeth. Neither at this nor at any other time were there convulsions. On the evening of the third day there was slight arching of the back for a couple of hours. Sleeplessness and thirst were marked during the first four days. He showed no signs of improvement until forty-eight hours after admission; during the subsequent six days all the signs and symptoms disappeared gradually with the exception of the sardonic appearance, which can still be slightly noticed. He was discharged from hospital, cured, on the twenty-sixth day.

The following treatment was carried out: On admission the patient was given an anaesthetic and the wound was excised, a good margin of healthy tissue being removed all round. The cavity was washed out with hydrogen peroxide, left open, and dressed daily with tinct. iodi. Antitetanic serum was given intrathecally (after lumbar puncture), intramuscularly, and subcutaneously. The doses, expressed in units, were:

First day	... intrathecal, 1,500	... intramuscular	10,500
Second day	... " 3,000	... "	12,000
Third day	... " nil	... "	18,000
Fourth day	... " 3,000	... "	15,000
Fifth, sixth, and seventh days	6,000 units intramuscularly		
Eighth day	6,000 units subcutaneously		
Ninth day	3,000 units subcutaneously		
Tenth, eleventh, and twelfth days	1,500 units subcutaneously.		

Altogether, 94,500 units were given. A rise of temperature was noted during the first four days regularly at 6 p.m., three hours after the injection of serum. On the first day it rose to 101, on the second to 102, and on the third and fourth days to 105. There was no evidence of ill effect, and the boy looked quite well in spite of these high temperatures. To prevent bringing on convulsions, an anaesthetic was given for all injections except the subcutaneous. There was a marked serum rash, which cleared up soon after serum treatment was discontinued. In addition, a mixture of potassium bromide gr. viij and chloral hydrate gr. viij was given thrice daily. The bowels were kept freely open. The diet consisted at first of nourishing fluids given frequently and in small quantities; later a light diet was given, and eventually ordinary diet.

A previous case, that of a woman, aged 37, in whom the incubation period was seven days, received similar treatment, except that the total dose of serum amounted to 33,000 units in four days—6,000 units intrathecally and the rest intramuscularly. In this case there were severe generalized convulsions every quarter of an hour, and death occurred on the fourth day.

The Royal Portsmouth Hospital.

T. V. CAREY, M.B.

THE report of the Gordon Memorial College at Khartoum has just been circulated; it contains an account of the varied activities of this well known institution. The College has now recovered from the limitations imposed upon it by the war, the vacancies in its scientific staff have been filled, and with Major R. S. Archibald, D.S.O., M.D., in place of the late Dr. Chalmers, at the head of the Wellcome Tropical Research Laboratories, a continuation of the series of researches noted by Dr. Chalmers in the present report is to be expected.

Reports of Societies.

GASTRIC AND DUODENAL ULCERS.

At the meetings of the Royal Glasgow Medico-Chirurgical Society held in the Faculty Hall on December 3rd and 17th, 1920, a discussion took place upon the "Treatment of gastric and duodenal ulcer." Professor RALPH STOCKMAN, representing the physician's point of view, pointed out that questions regarding treatment and subsequent results were by no means identical in gastric and in duodenal ulcers. Diagnosis was often very difficult and mistakes not infrequently occurred. Fortunately, in this discussion, diagnosis was not under consideration: they were dealing with accurately-diagnosed gastric and duodenal ulcers. It was known that gastric ulcer was common in anaemic young women and that duodenal ulcer frequently occurred in men in the prime of life and apparently in perfect health otherwise, but the reasons were unknown. Other facts were known, such as age incidence and morbid anatomy, but regarding the basic cause of these ulcers we were still very much in the dark. It was not known whether they were primary lesions, or secondary lesions following upon other unrecognized deeper lying causes. The importance of this in reference to treatment was self-evident, and if cleared up it might explain much in our failure to treat many of these cases more successfully.

Professor Stockman thought that to obtain the clear view necessary for the immediate question of treatment and its results, it was necessary to consider the recent and the chronic ulcers apart. It was certain that many people had acute ulcers of stomach and duodenum without any definite symptoms, and that the ulcers healed of themselves and probably never gave rise to further trouble. But if pain, indigestion, haemorrhage, or other symptoms supervened, so that we were fairly sure that we had an ulcer to deal with, clinical experience had put in our hands fairly efficient methods to allay these symptoms and presumably to induce healing. Absolute rest in bed was a first essential, so was light, easily digested food. Attention to the bowels and the administration of bismuth carbonate, magnesium carbonate, and possibly precipitated calcium carbonate, seemed in most cases to cause healing in from three to five weeks. A dietetic treatment based upon Lenhart's was found to be, on the whole, successful. Treatment was generally stopped too soon, and it was most important to endeavour to make sure that the ulcer was soundly healed. It should be possible to prevent its becoming chronic, for nearly all the prolonged ill health of gastric and duodenal ulcers was due to the ulcers becoming chronic and refusing to heal. Regarding systematic drug treatment to produce sound healing, physicians had shown a great want of enterprise. A marked feature was that many patients who had had gastric and duodenal ulcers kept well for long periods, but relapsed under worry, business and domestic strain, and exposure to cold. Anaemia should be carefully attended to. It was the chronic ulcer which gave trouble in practice. Many of its victims were never free from indigestion, pain, and poor general health; they had constantly to diet themselves: they might have recurrent haemorrhages, and their working capacity was greatly lowered. Medical treatment had shown lack of enterprise and initiative, and the treatment outlined above seemed to be the best we could do. Surgery claimed much regarding operative interference. While operation for perforation, pyloric stenosis, deformities, obstruction by adhesions, invasion of the pancreas, liver and gall bladder, often showed brilliant results, this was by no means invariably so. Cases of severe haemorrhage sometimes came into this category, but not often. The performance of gastro-enterostomy for the cure of uncomplicated chronic or recurrent ulceration did not stand on anything like this secure basis, and possibly it should not be done at all for this purpose. Regarding the claims made for it, almost every test showed it wanting. The strict rest and diet after the operation did good, but recurrences and trouble occurred afterwards very much as in unoperated cases. Regurgitation of bile was a dreadful sequel to the operation. In the past year, when discussing gastric ulcer at the British Medical Association annual meeting, Moynihan

stated that he had abandoned gastro-enterostomy as a method of treatment, his choice now falling on gastrectomy. Mayo, on the same occasion, advised gastro-enterostomy and burning out of the ulcer. But why operate at all? It was said to lessen the risk of perforation, but perforation was a rare occurrence, it could not be foretold, and could be dealt with efficiently by operation if it did occur. Excision of the ulcer was another operation which had been tried without immediate success, and it was claimed that this prevented the after-development of cancer. Cancer did not, however, commonly develop in the duodenum. If ulceration *per se* were the preceding and determining cause, one would expect to find cancer equally common in the duodenum. The matter was very far from being settled at present.

Mr. JAMES H. NICOL, representing the surgeon's side, remarked upon the impossibility of separating "treatment" from "etiology" and "symptomatology." Further, gastric and duodenal ulcers were absolutely different in two particulars—gastric ulcer tended to become malignant, duodenal ulcer practically never did. Gastric ulcer was common in young females, duodenal affected middle-aged men. In his opinion pancreatitis and gastric and duodenal ulcers were steadily following appendicitis, intestinal obstruction and cholelithiasis in that their immediate treatment was surgical. Referring to diagnosis, Mr. Nicol spoke of the results of physical examination, chemical and physical examination by test meals, radiography, gastroscopy, and exploratory laparotomy, and, having examined each method critically, concluded that the last word in diagnosis lay with the surgeon. With regard to treatment, not a few surgeons, including himself, were being steadily driven to the position that for these affections operation was the safe course. For duodenal ulcer, enfolding with closure of the pylorus was the proper course. This necessarily involved gastro-enterostomy. For gastric ulcer, excision or enfolding constituted the treatment; such treatment might or might not involve the super-addition of gastro-enterostomy. The decision in regard to that would depend upon the site of the ulcer and the degree of distortion of the stomach produced by the excision or the enfolding of the gastric ulcer. In regard to some points of detail:

(a) Large parietal incisions should be employed so that the other organs in the abdomen might be examined.

(b) Gastric and duodenal ulcers apparently cured by medical means not infrequently relapsed, perforated, bled, or became malignant.

(c) Microscopic examination of all excised gastric ulcers was advisable.

(d) When gastro-enterostomy was called for alone or in addition to pyloric closure or excision of the ulcer, in most cases the ordinary posterior operation answered well. When this led to bile regurgitation the surgeon must fall back upon one of three methods: (1) Gastro-enterostomy *plus* entero-enterostomy; (2) Roux's gastro-enterostomy "en Y"; (3) a modification of that permitting of side-to-side union.

Dr. R. O. ADAMSON presented the case from the point of view of the general practitioner. Sooner or later the majority of cases yielded to medical treatment, and in course of time diet and other treatment was relaxed. Owing to the exigencies of practice many cases of beginning ulceration were treated without having been investigated with the complete thoroughness that it would be best they should have, so that probably many were cured because they were treated in their earliest stages. Not infrequently later events proved that ulcer had been present. So, further, if the presence of ulceration was definitely proved, and the treatment then was more careful and more prolonged on the familiar lines, cure would result in a number both of duodenal and gastric ulcers. In numbers of cases the cure, however, was only partial, in so far as the ulcer was not completely and soundly healed. The patients, once the symptoms had disappeared, returned to unhealthy surroundings, to food wrong in quantity and quality, to conditions which in one way or another led to the return of their trouble, with the old symptoms. The ulceration became more difficult to heal, and they merged by degrees into the large class of chronic and recurrent cases. What seemed to be required was a much prolonged after-treatment in the early cases, for the frequent recurrence was apt to be followed by those deformities of the stomach, the pylorus, and duodenum which might be worse than the primary disease. Dr.

Adamson then considered in more detail how the cases presented themselves to the practitioner. He believed that after-treatment should be continued not for weeks or months, but for years. The question of suitable diet was all-important.

Dr. JOHN COWAN said that the mortality was considerable, and in a series of 120 patients who were in his wards suffering from some form of ulceration of the stomach or duodenum 15 died—that is, 12.5 per cent.; 8 died from haemorrhage, 4 from perforation, 1 from toxæmia, 1 from exhaustion, and 1 from unascertained causes a few days after leaving hospital, refusing operation. He thought that syphilis was an occasional cause of ulcer in adult men. He had recommended operation in 21 patients (17.5 per cent.), and in 2 others operation had been required within a short period of their discharge from hospital. Operation had been performed in 17 cases—7 times on account of recurrent haemorrhage, 7 times on account of dilatation of the stomach, thrice for a perforation; two of these patients died, both from perforative peritonitis. The ulcer was situated in the duodenum in 10 cases and in the stomach in 6. In the other patient no ulceration could be discovered at the operation. In another patient, who died from haemorrhage, a small erosion proved the source of the bleeding. In treatment the best results were obtained by the close co-operation of physician and surgeon and careful examination by every possible means of the particular features of each individual group. In his series the mortality in the operation group was 11.7 per cent., and in the non-operation group 12.6 per cent.

Dr. SOUTTAR McKENDRICK said that the frequent occurrence of severe haemorrhage in duodenal ulcer suggested the question whether operation was justified in all cases. In the operation of gastro-enterostomy the physiological mechanism received a shock. Peristaltic action was disturbed and the nervous mechanism thrown out of gear. Undigested food was hurled into the small bowel where the intestinal juices were incapable of digesting it, with the consequence of flatulence, eructations, and possibly diarrhoea. Should operation not be limited to gastric and duodenal ulcers with severe recurrent haemorrhages, pyloric stenosis, gastric tetany or perforation, or where there was evidence of a localized peritonitis or subphrenic abscess? The x-rays would be a reliable guide when the results obtained were carefully interpreted. When the stomach emptied in five or six hours, prolonged medical treatment should be applied to patients resting in bed. If pyloric stenosis followed, operation could be resorted to. Occult blood in the faeces was not a sufficient reason for operation.

Sir KENNEDY DALZIEL agreed that a large proportion of gastric ulcers required operation. He had been much troubled with one type of gastric ulcer—on the lesser curvature, when there was nothing at the pylorus or in the rest of the stomach. Although a great deal of treatment was tried, the patient's life was one of torture and discomfort. Acute ulcers did not call for operative treatment except after treatment had first been tried. In America the feeling was that gastrectomy was the right operation. How many physicians or pathologists had seen a healed chronic ulcer? Regarding the results of gastro-enterostomy, the results were better than they had been; bad results were often due to the maladroitness of the surgeon who produced traction. In a proportion of cases bilious regurgitation followed, and required subsequent treatment to correct. He thought that surgery should acquire a better technique. He had been struck by the good results of extirpation when this had been required.

In resuming the discussion on the second date the Chairman, Professor WALTER HUNTER, referred to the question of a syphilitic ulceration of the stomach, citing a case in which specific treatment was followed by cure, which was demonstrated by x-ray examination. Another case was referred to where there was profuse vomiting of blood, the Wassermann test was negative, but the haemoglobin was only 20 per cent. At present this patient was doing well with rest in bed, and later x-ray examination would be carried out, and if stenosis of the pylorus was present, the question of operation would be considered.

Dr. G. HERBERT CLARK said that until doctors familiarized themselves with the results of physiological research upon the functions and actions of the stomach and duodenum

treatment was liable to be only symptomatic. Why operative interference by gastro-enterostomy very often failed, when there was no marked stenosis and consequent delay and dilatation, was that the emptying of food and acid-juice mixture—not properly triturated chyme—occurred far too rapidly, and intestinal and other troubles followed. The gnawing pain, he thought, was largely due to muscular action; there was an effort by antiperistaltic action to return food unsuitable to the mucous membrane and digestive juices of the stomach. He considered that if the patient took the same care in the way of rest, diet, etc., without operation as he had to take after operation, his relief would generally far outdistance any benefit he would obtain from surgical intervention.

Dr. W. R. JACK said that most physicians agreed as to the type of case suitable for operation, but that surgeons took a wider view. In his experience where, in acute gastric ulcer with hæmorrhage, an operation was performed to tie the vessel, the surgeon invariably failed. In other similar cases ordinary methods of medical treatment had repeatedly succeeded. He asked for late results from surgeons. Most methods succeeded temporarily and sometimes for years, but he wished to know if surgical relief was greater than medical and more prolonged.

Dr. H. E. JONES, as a general practitioner of over twenty-five years' standing, remarked that whereas the physician and the surgeon saw the cases often after long duration, the practitioner saw them at the beginning, during and after treatment. He referred at length to the different types of case—of ulcer and of simulated ulcer—seen by the general practitioner and commented upon the probable effect of the prolonged rest after operation upon the body and mind of the patient. Mr. ALEXANDER McLENNAN was certain that in every case all available measures of investigation into the condition should first be applied. X rays, used for screening and for photographs, as well as chemical methods, were necessary. Where the stomach was posed without pyloric stenosis surgical interference was not indicated, although if an ulcer existed the sufferer was in a most unhappy condition. So also was the patient who after operation suffered from regurgitation of bile with vomiting and distension. He spoke of the method of stretching the pylorus digitally for dilatation of the stomach as having proved satisfactory. When laparotomy was done for perforation, should a gastro-enterostomy be done at the time? His colleague, Mr. William Campbell, usually did not do a gastro-enterostomy at the time, and many cases did very well without any further operation. The Mayos said that a perforated duodenal ulcer, for some unknown reason, healed better than an unperforated one. Ulcer of the duodenum did not heal nearly so well as ulcer of the stomach.

Dr. DOUGLAS RUSSELL said he was becoming increasingly reluctant to advise operation, but believed more in mental and physical rest. Small doses of opium seemed to do good. Mr. ARCHIBALD YOUNG remarked that there seemed to be a purely medical view and a purely surgical one; only by combining these could one arrive at a useful conclusion. From the point of view of the surgeon it might be said that the surgeon had to deal with the chronic ulcer. A proportion of acute cases with perforation or alarming bleeding of course occurred, but the majority were chronic. Therefore he asked whether the statement that a chronic ulcer never healed was or was not true. After all, why should it not heal? Was there anything in its nature different from other ulcers? Could all symptoms disappear, perhaps permanently, and the ulcer still remain? The view appeared inconsistent with the facts of pathology and the symptoms of disease. Few surgeons had not at operation seen evidences of healed gastric and duodenal ulcers. His own experience had convinced him that posterior (no loop) gastro-jejunostomy, without ligature or closure of the pylorus, would give good results in a large proportion of cases.

LEFT-HANDEDNESS.

At a meeting of the Liverpool Medical Institution, held on January 6th, with Dr. J. E. GEMMELL (President) in the chair, Dr. C. J. MACALISTER read a short paper on left-handedness and conditions associated therewith. After referring to some of the theories concerning the hereditary explanations of right-handedness and left-handedness and

the statistics concerning the proportionate incidence of the latter as compared with the former, he indicated that he did not wish it to be suggested that every case of left-handedness was liable to the functional disorders or ataxias to which he directed attention. By far the greatest number of left-handed people were perfectly normal physiologically, but he particularly referred to certain abnormalities which he felt sure depended upon transposed function. He showed a case of a left-handed girl, aged 13½, who was practically aphasic, whose language was one of signs and gesticulations resembling those natural ones used by the deaf. She had a fair amount of intelligence and a wonderful memory, her backwardness depending, to a certain extent, upon simple lack of education. She was being taught to sign and to read and write by the methods adopted among deaf-mutes. Dr. Macalister laid great stress upon ancestral and collateral history as bearing upon the question, and instanced cases of left-handed stammerers having left-handed relations, and of right-handed stammerers also having a left-handed ancestral history. He suggested that these marked inco-ordinations might be related in some way in the left-handed to the right speech centre being unbalanced by some unusual development of function of the left one, thus giving rise to a confusion of co-ordination. The same principle applied to cases of chronic hemichorea. Having noted that although transposition of the viscera might be thought to be associated with left-handedness, this was not constantly the case, there being a good many records of this condition where there had been right-handedness. Undoubtedly, in a certain number of cases, left-handed people had left speech centres, as proved by those cases of cerebral hæmorrhage affecting the right speech motor area where there was no aphasia. He quoted cases described by Foster Kennedy in which injuries involving the right Broca's areas in left-handed people had not been associated with defects of speech, and another series of cases of right-handed people showing similar peculiar results, involvements of the right Broca's areas being associated with aphasia. Kennedy's argument was that where there was a known hereditary or collateral history of left-handedness the speech centres appeared to have been transposed, whereas, in a number of cases of which no such history had been discovered, transposition had not taken place. In all probability there might be a Mendelian explanation of this, and that the occasional incomplete cases as well as the complete ones might be the result of hybrid marriages. The normal physiological inco-ordination depending on handedness referred not only to the general motor system, but it had another curious association, there being normally a strong side and a weak side to the body, a fact which applied not only to physical strength and dexterity, but had a bearing upon vitality and susceptibility to disease. He had frequently demonstrated that not only congenital malformations but also a number of acquired diseases tended to attack the weaker side.

A MEETING of the London Association of the Medical Women's Federation was held, on January 11th, at the Elizabeth Garrett Anderson Hospital, Mrs. FLEMING in the chair. Dr. MARY BELL read a paper on psychological forgetting in relation to lying, giving of evidence, and medical histories. In the course of this she suggested that the tendency to replace accurate by phantasialed memories should be considered much more seriously in courts of law. In the recent Greenwood poisoning case a year elapsed between Mrs. Greenwood's death and the final trial. "Which one of us (asked Dr. Bell) could remember the details of any one Sunday in 1919? It is true they might remember events during the evening when it was realized that Mrs. Greenwood was seriously ill, or if the possibility of poison had arisen at once they might have reconstructed the events of the earlier part of the day and kept them in mind, but as far as we know there was no intensity of feeling attached to the forenoon of that day. Any evidence given for the first time six to nine months after Mrs. Greenwood's death as to whether Mr. Greenwood went into the pantry or not, or as to who drank wine on that particular Sunday, must, to my mind, be pure phantasy." A remarkable instance of phantasialed memory occurred also in the Tichborne trial where the claimant was accepted from the first as her son by Lady Tichborne, though he differed completely from him in physique, in way of speech, and though she even recognized that the account he gave of past events was very confused and differed from her own. Dr. Bell's paper was followed by a short discussion, in which Dr. HELEN BOYLE, Dr. PAYNE, Dr. BRISQ, Dr. LOWRY, and others took part.

Rebielus.

A STUDY OF THE LONG BONES OF THE ENGLISH SKELETON.

THE Department of Applied Statistics of the University of London has issued the first two sections of Part I of *A Study of the Long Bones of the English Skeleton.*¹ It deals with the femur. The authors are Professor KARL PEARSON and JULIA BELL, and the work is published as the tenth biometric series of the Drapers' Company Research Memoirs.

In his prefatory note Professor Pearson tells us that the work was started twelve years ago merely with the intention of illustrating the application of biometric methods to a special field of anthropometric inquiry. During these twelve years, however, biometric methods have come into more general use, though the author thinks there still remain anthropometricians who believe elementary arithmetic adequate for their science. If such there be, or if Professor Giuffrida-Ruggieri still thinks as he thought in 1905, that English anthropology, being merely descriptive, no longer counts in science (quoted by Pearson), these volumes must surely convince them of their error.

Karl Pearson is a world-wide authority on statistics, his methods are standard, and in his application of them to the present subject he conveys the impression that the truth and nothing but the truth is what he seeks, and moreover that by these methods of mathematical exactitude it will be found. That statistical work "is absolutely primary and the only safe road to generalization" is the authors' contention. After reading these volumes, the reviewer will be unable to accept conclusions unsupported by a statistical presentation of the case. "School-boy arithmetic," which draws conclusions from percentages based on small numbers, and without appreciation of the probable error, will no longer suffice. Throughout the work, whatever the point in debate—the source of the normal bowing of the femur, or the lines of evolution from the anthropoids to recent man, or whether woman be more ape-like than man (a charge the authors find non-proven)—the facts are clearly stated and assessed at their mathematical value, often in the form of a tetrachoric correlation accompanied where needful by the probable error.

From all this it will be gathered that the English long bones are not the only subjects of discussion in these volumes, and the authors admit that as the twelve years went by they found the ever-widening interest of their subject carrying them ever further afield till their essay was becoming a monograph on the primate long bones. They tell us, indeed, that they regretted not having begun with the femur of the lower primates, for then they would have known better what anomalies of the human femur (such as a posterior fossa) to look for, and what measurements would have been found suitable or unsuitable for comparisons. Some measurements, such as the pithecoïd index and indices found on the direct and oblique lengths of both condyles (not hitherto taken on the human subject), were found eminently suitable; others, such as the platymeric index taken in the subtrochanteric region, quite unsuitable, owing to the varying position of the maximum flattening. The authors apologize, too, for the want of balance this widened interest has given to the monograph, since in the case of one species (man) 80 to 100 characters have been determined on the femur of 800 skeletons, whereas it has been impossible to obtain an equivalent series of any other species. Material and, later, owing to war exigencies, time and workers were wanting. The scientific public assuredly will not regret this widened scope, and they will sympathize the more with the authors in their plea for a general use of standardized femoral measurements for better use of rare material—the measurements of such a treasure as the Trinil femur are still unpublished—for more material, sexed and complete if

possible, but at least that collectors should remember that other bones besides the skull are worthy of storage in a museum.

The first five chapters are illustrative of the application of biometric methods to the study of a single long bone. They deal with measurements taken; anomalies of the femur; the typical English femur, its comparison with that of other races; variability of the English femur, its comparison with that of other races and of other bones, and the influence of side and sex. In Chapter I it is noteworthy that "maximum length" is more closely correlated with stature than "oblique length." In the chapter on sexing it is shown that there is a very close agreement between anatomical sexing and mathematical sexing, though the latter is proposed only as a control. To test the sexing value of any measurement, overlapping Gaussian curves (a dichotomy) of this measurement taken on an approximately equal number of male and female bones are made, and if the distance from the male to the female mean be about twice the standard deviation of one or other sex the measurement may be regarded as useful. The authors note that since the sex differences are often less than the racial differences, mathematical rules for sexing must be deduced afresh for each new series. Under "anomalies" we find a most interesting discussion on the third trochanter and the gluteus maximus, in the course of which the third trochanter is exonerated from being a stigma of degeneration.

In fixing the type of the English femur the authors found great difficulty in utilizing the work of others, owing to want of standard measurements, selection of too few characters for measurement, and the small numbers dealt with. Nevertheless, an extensive table is given of the means (with probable errors) of English femoral characters, and a comparison with those of other races. The authors suggest that the defect of obliquity and torsion, and the excess of antero-posterior dimensions of the right femur are an associated system, and embrace the main differences of size and form between right and left bones; and dealing with the influence of sex they note that as far as their data for the femur go they do not confirm the views that have been propounded by certain authors that the sexes differ by arrested development, or that one sex is more primitive or more ape-like than the other. Examination of the comparative variability of the sexes shows that the female femur is slightly more variable than the male in civilized races in spite of the greater fixity of the proximal epiphysis and in contradistinction to certain vigorous writers.

Chapter VI opens with a remarkable table of 344 of the chief correlations of the characters of the London femora, followed later by a table of the differences of male and female correlations. In the discussion of these tables the interesting point is emphasized that the mean projection of the centre of the head of the femur beyond the mid-trochlear point on the mesial side is in the male four and in the female three times larger on the left than on the right side, and the widened scope of the monograph becomes apparent in references to evolutionary changes and Mendelian units.

Chapters VII to X, comprised in Section II, deal with the general and diaphysal femoral characters in man; the comparison of the femur of man with the femora of other primates; characters of the epiphyses; examination of the dwarf femur; comparison of the femora of the anthropoids, of primogenital man, and of recent man. In Chapter VII we meet with the pithecoïd index ($100 \times$ trochanteric oblique length / oblique length), introduced as a means of interspecific comparison of the relation the tops of the great trochanter and of the head of the bone bear to each other (in man the head of the bone is at a higher level, in simian femora the top of the great trochanter is at the same level or even higher), and it is found that for this character *Pithecanthropus erectus* is essentially modern man. Indeed, for all characters the authors have been able to study the femur of *P. erectus* (the Trinil femur) is recent human. From the same study of general femoral characters the authors conclude that the human femur has a troglodytic rather than a hylobatic origin—that is, man is nearer the greater anthropoids than the gibbon, *qua* his femur.

The interest of the work now frankly centres round the descent of man. Every point is examined with mathematical exactness, and since the authors have made use of the work of others they have been led to scrutinize their

¹ *A Study of the Long Bones of the English Skeleton.* By Karl Pearson, F.R.S., and Julia Bell, M.A. Drapers' Company Research Memoirs, Biometric Series XI. Part I, Chapters I to VI, The Femur. Part I, Section II, The Femur of Man, with Special Reference to other Primate Femora. London: Cambridge University Press, H. L. Lewis and Co., and William Wesley and Son. 1919. (Pp. 559, with illustrations and diagrams, accompanied by atlas to Part I, 59 plates and 2 tables, and atlas to Part I, Section II, 44 plates and 2 tables. Text and atlas, Part I, 30s.; text and atlas, Part I, Section II, 40s.)

figures with the same care. Only too often, as with the collar angle (Chapter VIII), which is given by one authority as 119 degrees and by another as 130 degrees for the Australian aboriginal, want of standardization makes the figures almost worthless. Yet, in spite of all difficulties, reasoned conclusions are reached, and in the succeeding chapters there is unfolded a scheme of the descent of man based on mathematical examination of the evidence of the femur.

In discussing the distal epiphysis (Chapter IX), under consideration of the retular index (measuring roughly the ratio of articular surface height to breadth), the authors make the point that if the long-tongued patellar articular surface be associated with the power of spring, then a big factor in the history of the evolution of the primate femur is the replacement of this power of springing by power of upright gait. In this respect the measurements of recent man show that as compared with Neanderthal man he has recovered some of the ape power of spring, and is in this character reverting to the ape.

In their own mathematical researches into the pedigree of man the authors have made no use of size, but have dealt only with indices. The method is described in Chapter X, and leads to most interesting results. What the authors call mean indicial deviations, deduced from the reduced indicial deviations of (1) the general indices of the femur, (2) the indices of the shaft, (3) the indices of the "bust," (4) the indices of the distal epiphysis, and the mean indicial deviation of (5) all the forty indicial characters concerned in the above, are used to plot five corresponding radial diagrams showing the relation for each set of indices and for the pooled indicial characters of recent man, Neanderthal man, *Pithecanthropus erectus*, dryopithecus, orang, gorilla, chimpanzee, gibbon, and in some cases Tarsius, to each other and to a central simio-human point and axis. The general result is that recent man is far the closest to, and the gibbon and gorilla the furthest removed from, the simio-human mean in femoral characters. This result is in accord with the conclusion the authors reach from a consideration of the anomalies of the femur. The prot-simio human femur is expected, when found, to have human *plus* chimpanzee, and not *plus* gibbon, features.

The authors recognize that this is a bold deduction from the study of a single bone, but they plead that the chief aim of this monograph has been and will continue to be the discovery of how much can be ascertained from the intensive study of single bones. There is more to come—studies of the humerus and tibia—but workers are few, expenses enormously increased, and material often difficult to obtain. Every one who has read these volumes will sincerely wish the authors may overcome their difficulties. To cease, or even curtail, such publications would be a scientific disaster.

Throughout the work tables of measurements, indices, ratios, means, comparisons, are given wherever necessary. They form, indeed, a large part of the printed matter, and the authors have spared themselves no trouble in their desire to exhibit clearly the groundwork of their argument. There are three short but interesting appendices on the correlation of the femoral characters in man, femora of fossil lemuroids, and the sesamoid bones of the knee. The bibliography is a standing testimony to the authors' thoroughness in seeking and appraising the work of others. Each of the two sections is accompanied by an illustrative volume, chiefly photographic, and of great excellence. The atlas to Section I is accompanied by a table of all the measurements made on the London bones, that to Section II by two tables of measurements and descriptions of femoral characters of the primates (man, anthropoids, lesser apes, and lemuroids), which by themselves are works of reference.

We heartily congratulate the authors on their great achievement, and the Drapers' Company on the wise use made of their funds.

J. G. TURNER.

PSYCHONEUROSES OF WAR AND PEACE.

DURING the war the problem of functional nervous conditions more or less forced itself on the notice of Dr. MILLAIS CULPIN while he was engaged upon work as a surgical specialist. He fortunately realized the functional element in many of his surgical cases, and the interest of

the psychoneuroses led him subsequently to devote all his energies to this branch of medicine. The experience he thus gained is recorded in his book on *Psychoneuroses of War and Peace*.² It is clear that the views herein developed have been gained from personal observation and in close contact with clinical material. Dr. Culpin feels his way carefully. He keeps the therapeutic aim always in the foreground. He is cautious in accepting theories, and he only does so in so far as they harmonize with facts he has observed for himself. In the preface he indicates that one object of his book is to discuss the bearing of the theory of the unconscious upon psychoneuroses found in soldiers. In summarizing his views Dr. Culpin says he finds that the existence of repressed but activating memories renders the theory of the unconscious "necessary to the understanding and treatment of the neuroses." A certain reluctance seems to be evident in this admission, and it may be that he would be glad to find some formula, expressed in terms of the "organism as a whole," which would serve to replace the no doubt necessary but somewhat unsatisfactory concept of the unconscious. The trend of psychology in certain directions would seem to justify the hope that such a formula may ultimately be found. Since Dr. Culpin only accepts this fundamental hypothesis after careful consideration of the facts before him, it is not surprising to find that he does not give full adhesion to any of the more specialized schools of thought.

The inclusion of psychasthenia in his classification indicates a conservative attitude. In this we think he is wise. In spite of the tendency to split up this clinical group the necessity for such a procedure is doubtful. At the risk of being regarded as old-fashioned we would express the opinion that Janet's psychasthenic group is a most useful clinical concept, and it might well remain more or less as he defined it. Furthermore, the broad biological generalization which he formulated in regard to the protective character of neurotic symptoms has been abundantly demonstrated as true of the war neuroses, and the influence of his views tends to become increasingly apparent, though they have, of course, been illuminated by more recent developments.

Dr. Culpin finds it necessary to explain the phenomena of the psychoneuroses by reference to the censor. This term has been much criticized, and on grounds which appear reasonable. It is not easy to accept this concept with any degree of satisfaction, and such phrases as "the Censor is firmly entrenched in the unconscious" and "the Censor is clever at hiding his work" are assimilated with difficulty. Such an artificial explanation of a natural biological process stands in obvious need of revision.

A certain number of cases are here grouped under the heading of "Weak herd instinct." The reference is to those cases in which "the sense of discomfort or fear was always present in the consciousness" and in which personal interest overcame patriotism. We recall that Dr. S. I. Schwab found it useful to define a somewhat similar group under the heading of "Timorousness or state of anxiety."³ In regard to treatment, the author follows no hard-and-fast lines, but bases his general treatment upon the revival of repressions. He gives an account of his technique, and then devotes attention to dreams, phobias and obsessions, hysterical fits and epilepsy, stammers and tremors, gross amnesia and pathological irritability, and these symptoms are illustrated by reference to actual cases. The book will be found of interest and value to those who are concerned with the care and treatment of the still large number of nervous pensioners.

ANGINA PECTORIS.

MR. WALTER VERDON'S work on *Angina Pectoris*⁴ contains a mass of material and interesting accounts of cases more or less illustrating his views, on which he has already published many short communications. The later pages of the volume are devoted to other papers, especially to the subject of "Protective Reflex Action" (Appendix II). One of the great questions discussed in the book is the association of angina pectoris with gastric disorders and

² *Psychoneuroses of War and Peace*. By Millais Culpin, M.D. Lond., F.R.C.S. Eng. Cambridge University Press, 1920. (Demy 8vo, pp. 127, 10s. net.)

³ The War Neuroses as Physiologic Conservations. Dr. Sidney I. Schwab. *Archives of Neurology and Psychiatry*, May, 1919.

⁴ *Angina Pectoris*. By Walter Verdon, F.R.C.S. Brighton: W. T. Moulton and Co. 1920. (Demy 8vo, pp. 429; 8 figures.)

"windy stomach." The main facts on this subject are well summed up in three passages quoted by the author from Sir Clifford Allbutt:

"Dilatation of the stomach by some processes of sympathy or exhaustion may be induced by angina pectoris; it is frequently associated with it. Broadbent and myself made this observation, and so before us did Elsner explicitly. We have noticed that eructation often signifies relief." "If gastric ectasis is not to be reckoned as a correlated symptom of angina, the coexistence is by no means to be overlooked, as the mere oppression of it may provoke the recurrence of seizures, or even determine the moment of death." "Whatever the nexus, whether a vagus reflect from heart to stomach, or a mechanical butting at the heart itself, we are not yet in a position to say. Every day experience tells us that cardio-aortic maladies are mitigated by rules of diet which guard against generation of wind in the stomach, and are relieved by cordials which expel it, when there."

Mr. Verdon himself (p. 51) remarks:

"The really important questions to explain are, not as to how gas gets into the stomach, but when there, how does its presence initiate and sustain seizures, and how comes it to pass that the wind and pain are discharged together?"

For the author's explanations in answer to these questions we must refer readers to the book itself. Sir Clifford Allbutt has adduced evidence to show that death in angina pectoris results from vagal inhibition, and Mr. Verdon explains the infrequency of death during seizures (p. 66) as a paradox due to the activity of sympathetic centres inhibiting activity of vagal centres. In support of the view that exhaustion of the reserve contractile power of the heart is not necessarily the causal agent of angina pectoris, he adduces the example of a patient walking ten miles just after several seizures. He also confirms Allbutt's summary, "that disease of the coronary arteries does not set up angina is an axiom founded on universal experience." Mr. Verdon, however, concludes (p. 81):

"It is thus gathered from statistical evidence that the effect of coronary disease on the causation of the angina pectoris is nil; nevertheless, its influence in determining a fatal issue when angina is present is great—a myocardium impoverished through the attenuation of its nutrient supply soon falls victim to vagal inhibition."

He likewise argues that disease of the aorta, although a causal agent of the segmentary neurosis manifested by attacks of angina pectoris, is not the predisposing nor yet the exciting cause of seizures. In Auscher's case the necropsy showed definite signs of old pericarditis, while the aorta was quite healthy. In regard to high blood pressure, he refers to patients in whom a brachial systolic blood pressure of 200 to 300 mm. Hg during ten to fifteen years has not provoked a single attack of angina pectoris. According to Mr. Verdon the predisposing cause of anginous seizures is most probably a segmental neurosis.

The book, which is the outcome of much observation, thought, and long-continued attention, should be in the hands of those interested in the various doubtful questions connected with the subject of angina pectoris. The usual sites of pain and the other symptoms are especially carefully discussed. The local roughness and induration of the skin produced by frequent scratching in certain anginous subjects (p. 46) is surely what is now generally known as local "lichenification," and is not at all directly connected with angina pectoris. The use of the term hysteria, on p. 339, is rather confusing: "A very mild type of segmentary neurosis passes under the name hysteria. In this instance the uterus is primarily at fault."

ROENTGENOLOGICAL METHODS.

The scope of *The Principles and Practice of Roentgenological Technique*,⁶ by Dr. I. SETH HIRSCH of New York, is strictly limited, and questions of x-ray diagnosis do not come under consideration. The object of the author is to put before the student of roentgenology only those principles of technique which will serve him best on the difficult road to the goal, roentgenological diagnosis and therapy. With this object in view it is not too much to say that he has entirely succeeded. The whole book teems with information of the greatest possible value, presented in a lucid and practical manner; the explana-

tions are expressed in language easily read and understood, and a large number of illustrations serve their part in making the text quite clear. Of its two main parts, the first considers principles of technique, describes all the apparatus generally in use, explains its purpose and the ways in which it is employed, and gives a fair amount of information on the physics of radiography. The second part deals in the main with descriptions of position for the patient and the x-ray tube for each variety of x-ray examination; in each case a photograph is given, and makes everything clear to the eye. Reproductions of radiographs side by side with these photographs indicate the results of the actual exposures. There is a useful chapter on the principles which guide times of exposure, and, amongst other points, reference is made to the influence of the size of the part to be examined and the sensitiveness of the plate; an elaborate set of exposure tables which furnish every detail are given. There is a chapter on development and the dark room, and another on the x-ray laboratory. The latter gives diagrams of the arrangement of apparatus which will be of value in fitting up a hospital or a private installation. The book is remarkably well printed and the numerous illustrations, whether diagrammatic, photographic, or radiological, are of the highest merit. The student of radiography will find this a textbook of great value, the expert and experienced worker cannot fail to appreciate its merits as a book of reference.

NOTES ON BOOKS.

THE eighth annual conference of the National Association for the Prevention of Tuberculosis was held in St. George's Hall, Liverpool, on October 7th, 8th, and 9th, 1920. A summary of the proceedings appeared in our issue of October 16th, 1920, at p. 603. The full official *Transactions*⁶ of the conference have now been published. The papers are grouped under three headings: (1) Review of methods of prevention and treatment of tuberculosis advocated from time to time, the extent to which they have been followed, and the results obtained. (2) Practical difficulties in connexion with the carrying out of tuberculosis schemes and the best measures to overcome them. (3) Milk as a source of infection, and the preventive measures to be employed. The volume is well printed and contains much of interest and importance.

Dr. NOEL BARDSWELL's little *Handbook for Tuberculosis Workers*⁷ discusses, in non-technical language, the causes of tuberculosis, its manifestations and treatment, and the methods of antituberculosis administration. It is distinguished not only by clearness in scientific exposition, but by sound common sense on such important points—usually overlooked—as the adjustment of financial troubles and the remedying of insufficient income in small households when the wage-earner is stricken down by ill health.

The fifth edition of Dr. CHARLES PORTER'S *School Hygiene and the Laws of Health*⁸ contains some new matter which adds very much to its usefulness. In the chapter on infectious diseases an account is given of bacteria and the manner in which disease is spread, and the expression "carriers" is well explained. There are three entirely new chapters, dealing respectively with medical inspection of schools and school children, welfare of infants and young children, and special schools. A good deal of accurate information is included in the three pages devoted to special schools, in which open air schools, school camps, nursery schools, and cripple schools are referred to. The chapter on sanitation and cleansing is one which should be of great use to teachers and school managers. Few will disagree with Dr. Porter in his condemnation of trough closets for schools, a condemnation it may be observed which appeared in the first edition of his book in 1906. We are unable to endorse his apparent approval of "ash-closets," in which riddled ashes are used. Earth has a nitrifying action upon excreta, but ashes are sterile, and cannot therefore have any such action.

⁶ London: Adlard and Son and West Newman, Ltd. 1920. (Post free 12s. 6d.)

⁷ *Handbook for Tuberculosis Workers*. By N. Bardswell, M.V.O., M.D., F.R.C.P. London: J. Bale, Sons, and Danielsson, Ltd. 1920. (Post 8vo, pp. 70. 1s. 6d. net.)

⁸ *School Hygiene and the Laws of Health*. A Textbook for Teachers and Students in Training. By Charles Porter, M.D., B.Sc., M.R.C.P. Edin. Fifth edition. London: Longmans, Green, and Co. 1920. (Cr. 8vo, pp. 381; 117 figures. 6s. 6d.)

⁶ *Principles and Practice of Roentgenological Technique*. By I. Seth Hirsch, M.D., Director of X Ray Departments, Bellevue and other Hospitals, New York City. New York: The American X Ray Publishing Co.; London: H. K. Lewis and Co., Ltd. 1920. (Cr. 4to, pp. 264; 311 figures; 22 tables. 60s. net.)

All workers in chemical pathology will be greatly indebted to Professor CAVAZZANI for his excellent little book on the proteins of the urine.⁹ The first two chapters are devoted to a qualitative description of the proteins found in the urine. This is followed by an excellent account of all the latest methods for the quantitative estimation of the various urinary proteins, and full justice is done to the pathological implications of the subject. A very useful analytical chart is appended. The bibliography is exceptionally complete, and the monograph will save much time and trouble to research workers.

⁹ *Le Proteine dell' Urina*. By Emilio Cavazzani. Ferrara. 1920. (Pp. 163.)

APPLIANCES AND PREPARATIONS.

Surgical Needles.

MR. BRYDEN GLENDING, M.S., F.R.C.S., Aspley Guise, Beds., writes: Some six years ago Messrs. Allen and Hanburys made for me both round-pointed and cutting curved needles with square bodies, to my special measurements, in sizes 9, 12, 15, and 15 fine. The ordinary curved cutting needles are usually made with either a flattened or too weak a shaft, so that in the smaller sizes they are often unequal to the strain put upon them. They are specially liable to break when used

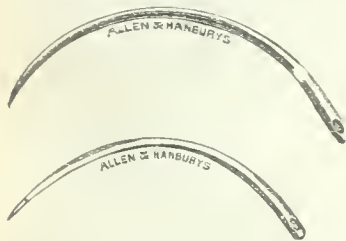

in dense fascias, scar tissues, and particularly in the cervix uteri, with annoying consequences. The round-pointed surgical needles usually supplied have always suffered from the disadvantage that, having round bodies, they tend to turn in the needle-holder. The square body obviates this, and, while in no way affecting their

general utility, makes it possible to use them in all except fascial structures with much less injury to tissues and vessels than with cutting needles. Six years' continuous use of these needles has impressed upon me their advantages, and suggests to me that if known they would be extensively used. They should have ordinary eyes, with the exception of No. 15 fine, which is spring-eyed and used for gut work.

An Improved Mouth Gag.

Major K. BLACK, F.R.C.S. Eng., surgeon to the Welsh (Ministry of Pensions) Hospital, Netley, sends us particulars of a new mouth gag, which has projecting plates extending inwards from the tooth-plates and set at a non-cutting knife edge; this, he states, allows the gag to be inserted between the teeth easily and quickly, even when the jaws are tightly closed. Anaesthetists will recognize that this non-cutting knife edge will prevent a delay which often is fraught with serious danger to the patient. In dental extractions it is found that with this gag the prop which is generally used becomes unnecessary. At the posterior and inner edges of the tooth-plates are ridges or lips, which effectually prevent the gag from slipping forwards and outwards when the mouth is forced open. (There are no

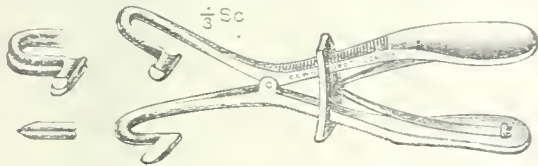

ridges at the anterior or outer edges, for the gag, when opened, does not tend to slip backwards and inwards. The mouth can be locked in the open position, so that the hand of the anaesthetist does not have to hold the gag once it is in position—an important advantage. The angles and length of the gag are so arranged as to give the greatest leverage possible combined with lightness and strength. The handle is broad and concave, and facilitates the action of the hand in opening the gag. There are *nine* serrations on the ratchet, allowing the gag to be fixed open in any desired position. The spring is detachable to facilitate cleaning. It is unnecessary and undesirable to use rubber to cover the tooth-plates. The gag is made by hand and can be obtained from Messrs. Down Brothers, St. Thomas's Street, S.E.1.

Soloid Neutral Red.

Messrs. BURGHOUS, WELLCOME AND CO. have added to their series of compressed microscopic stains a "soloid" brand of neutral red. Each 0.1 gram product dissolved in 10 c.cm. of distilled water gives a 1 per cent. solution. Neutral red is used for Gram's stain, and more particularly for Jensen's modification; also for Neisser's stain. These soloids are very handy for the quick preparation of microscopical stains in small quantities as required.

THE HOSPITAL PROBLEM.

BY

STANLEY RAW, M.D. DURH., F.R.C.S. EDIN.,
SURGEON, ROYAL INFIRMARY, SCOTLAND.

THE present voluntary hospitals are no longer voluntary in the sense for which they were ordained—namely, for the gratuitous treatment of the sick and lame poor—and the principal cause of the departure from original foundations has been the great widening of surgical scope in the past twenty-five years, so that—as is common knowledge—multitudinous cases are now operated upon in which operation would never have been suggested a quarter of a century ago. The natural result of this extension of scope is a greatly increased demand for its benefits, and in the main these can only be supplied in hospitals or nursing homes—in the former gratuitously, and in the latter at a prohibitive cost for the great bulk of the population.

To meet in some way the expenses of these new demands a system of workmen's contributions was introduced into many hospitals, and although in theory these contributions are considered to be personal donations to the charity, in actual fact they have come to be construed as being a sort of insurance premium, and the donors and their dependants are looked upon as having the right of admission, without further payment, to the hospital to which they subscribe, altogether irrespective of their financial position. In short, many voluntary hospitals are no more and no less than workmen's co-operative institutions where the regular subscribers and, save in emergency, no others—are admitted without further question.

I have no quarrel with this attitude. When workmen's subscriptions were first instituted they were given in the truest spirit of charity and generosity, and with the genuine idea of supporting a charitable institution which was doing good work for the poorer members of the community. Neither do I believe that there is any large degree of avoidable hospital abuse existing, at least in my own district. After all, the most unflinching law is the law of averages, and so far as my judgement goes I am convinced that every class of the population can be divided up into three categories: A small percentage of members is much above the average in intellect and character. Another small percentage is much below the average level in these respects. The third, large class, is composed of straightforward honest people, who want a fair article or fair service for a fair price.

I consider that there are very few people who have an operation done in hospital simply to escape paying a fee, and I am convinced that the majority of patients would gladly pay a fee provided that it can come within the range of their means, and further, their pride resents it being done for nothing. The position of the non-manual workers of the population who, despite the fact that they are in many instances no better off than the manual workers, have to go to nursing homes, need not, I think, be elaborated.

The last point I wish to mention before coming to my ideas of the best future for hospital treatment is the great increase in the amount of work and time that is demanded of the honorary staff. I confine myself to my own hospital. I now have the privilege of being an honorary surgeon to the hospital in which I was a house-surgeon fifteen years ago. There has been practically no increase in the number of beds, and nothing beyond the normal increase in the population, and yet the amount of work, as judged by the number of abdominal operations, has increased by 600 per cent.

I shall, I take it, be on common ground when I say there are three methods by which the hospital work of the country can be carried on:

- A. Voluntary hospitals.
- B. Hospitals supported out of public funds.
- C. Paying hospitals.

It is, of course, for the majority of the community to decide which of these methods they prefer. Here I wish to point out for their guidance what in my opinion these various methods mean and entail. I say nothing more about the value of my opinion than to mention that I was a house-surgeon for nearly four years; I have been an honorary surgeon for nine years; I served as surgeon to a hospital in France for nearly four years; I was, whilst waiting for surgical work, a general practitioner, and I am now a consulting surgeon perfectly content with my own individual lot.

The Voluntary Hospital.

All of us who have had anything to do with hospital work are attached to the voluntary system in general, and

our own hospital in particular, for it is the centre of our happiest professional associations, and we would gladly carry on in the old way. We cannot carry on in the old way for two definite sets of reasons. The first set of reasons has to do with the general expenses and necessities of hospital work, and amongst other things includes:

1. The greatly increased range of modern medicine and surgery, with all the extra work and expense attached to the necessary technique, methods, and special departments.
2. The greatly increased number of patients requiring treatment.
3. The greatly increased resident staff necessary to carry out the work.

The second set of reasons has to do with the visiting staff, and includes:

1. The appointment of various officers, such as anaesthetists, pathologists, x-ray specialists, etc., who, in the nature of things, must receive some financial remuneration for their services.
2. The greatly increased amount of work required from the regular honorary staff and the much higher standard demanded in this work.
3. The consequent greater difficulty for the honorary staff to find a sufficient source of income without engaging in general practice.

I, like most other surgeons of my acquaintance who have formerly been in general practice, am very glad indeed that, of necessity, I had that experience, but apart altogether from its science, the art of modern surgery is now such that it cannot be as efficiently carried out when the performer has to make his living in general practice as when he can devote his whole time to surgery, when, in fact, his surgical work is made a side line rather than the real business of his life.

If the above two sets of reasons are correct, the continuance of the present voluntary system becomes almost impossible, because:

1. It entails an expenditure which is hardly likely to be met by purely voluntary subscriptions, and which it is not altogether desirable should be so met; and,
2. It necessitates the bulk of hospital surgeons remaining in general practice.

Hospitals Supported out of Public Funds.

A hospital entirely supported out of public funds would necessarily have a paid staff, and in all probability the work of the staff would be confined to the hospital itself, and the benefits of their services restricted to the class eligible for admission to the hospital. The cost of maintenance would be greatly in excess of the cost of the present hospitals. The importance of the administrative side would be enhanced, and the importance of the clinical side would be diminished.

For these and many other reasons along similar lines, I am opposed to the establishment of hospitals entirely supported out of public funds.

Paying Hospitals.

As will be fairly obvious from my previous remarks, this is my view of the solution. To put it into one sentence my thesis is, "Medical or surgical requirement, and not poverty, should be the qualification for admission to hospital." I therefore advocate that the benefits of the hospital should be made available for all classes of the community that it serves, and that the only necessary qualification for admission should be the possession by the patient of some malady or injury requiring more than "ordinary medical attendance." Between certain limits all patients would pay for their treatment; the necessitous poor would be lodged, boarded, and treated free of charge; the moderately well off would pay the cost of their treatment, and the well off would pay such a sum as would leave a profit to the hospital. I venture to think that if such a system were instituted, the hospitals could actually be made to become self-supporting. I shall not now occupy any more space in working out this system in detail, for it is time enough to consider details when broad principles have been decided upon, but I should like to assist the adoption of these broad principles by advocacy from the following points of view:

1. *Efficiency and Expedition of Work.*—All hospital surgeons have performed operations in three places—their hospital theatres, nursing homes, and private houses—and all will agree that they do their work best in hospital and least well in private houses. Nor is this to be wondered at. In hospital they have their regular assistants, house-surgeons, and theatre staffs, all of whom know their ways and dovetail into the various stages of the operation. In addition to this, they have to their aid the elaborate apparatus of a large well equipped hospital. If these advantages are admitted as to the art of their craft, how

much more are they evident on the scientific and nursing sides of their work, when the opinion of physician, pathologist, x-ray specialist, can be obtained under the most favourable circumstances, and where the surgeon sends his cases back to his wards knowing that his nurses know almost as much about the after-treatment as he does himself. I do not mean for one moment to suggest that perfectly satisfactory results are not obtained in nursing homes and private houses; what I suggest is that in hospital the surgeon feels more certain that these results will be obtained, and he is therefore easier in his mind, and consequently a better craftsman. The greater expedition of work in hospital, I am sure, needs no further proof than is afforded by the number of cases a surgeon will do in one session at the hospital as compared with his lists elsewhere.

2. *Financial Benefit to the Community.*—There are four classes of patients who may have to be submitted to severe operations or complex medical treatment or investigation:

(a) The poor who can pay nothing, and who have been, are, and should continue to be, admitted to hospital without any personal payment, and for whose treatment voluntary subscriptions will still be needed.

(b) Those who can pay small fees, and who, in virtue of workmen's subscriptions, etc., are eligible for admission to their local hospital. Many practitioners tell me that they have any number of patients who could afford £10, £15, or £20 for an operation, provided that that sum included the whole cost of nursing, operation, and attendance, but who simply cannot afford the necessary cost of nursing homes. They further tell me that the majority of these patients would prefer to pay, and would welcome the opportunity to do so.

(c) Those who can pay small fees, but who are not eligible for admission to hospital in virtue of workmen's contributions, etc. This is, of course, the hardest hit class of all, and a serious operation in such a family is not only a surgical anxiety, but almost a financial disaster. It is, above all, the class that would rejoice at the opening of hospitals to their kind, where their nursing would cost them less than in a nursing home, and where surgeons could obviously afford to operate for much smaller fees than they are compelled to charge in a private home or house.

(d) The well-off, to whom the actual monetary cost is of little moment, but whose gain would be considerable from the point of view discussed in the next section.

3. *Economic Benefit to the Community.*—This will best be seen if I limit my argument to the consideration of surgical emergencies. How many acute surgical emergencies occur daily throughout the length and breadth of England I do not know, but the number must be considerable, even though we limit our definition to ruptured gastric or duodenal ulcer, intestinal obstruction in its many varieties, acute fulminating appendicitis, and similar impending calamities. What happens to a patient so afflicted? The "hospital class," if seen early enough by their own family doctor, can be immediately sent to hospital and operated upon within two or three hours of the first symptoms, and under no other circumstances can this consummation be achieved. We therefore have now a state of affairs in which the most skilled, industrious, and useful members of the community have a worse chance of recovery from a serious surgical emergency than have the least useful members. As individuals no one person has any more right to medical or any other benefits than another; but surely the time has arrived when the highly trained professional and business classes should be given an equal chance of recovery with the least skilled labouring classes. Therefore, open the hospital doors to them and let them get more quickly back to their places in the economic machinery than they are at present able to do.

4. *The Position of the Hospital Staff.*—This would be altered in many ways. Financially the more successful members would probably be less well off, but their scientific position would be so much more comfortable that any loss of income would be more than compensated for. I would suggest that the staff should receive a small retaining fee for their work in connexion with the non-paying patients, and that their remuneration for attendance upon the paying patients should be a matter of arrangement between them and the patients. The important thing is that the members of the staff would be restricted in their practices to their own particular variety of work, and, further, that they would only practise their own specialities as consultants. The benefits from this arrangement are too obvious to need tabulation, and they are so obvious that it is a matter of surprise that they have not already been secured.

5. *The Retention of the Spirit of Charity.*—This seems to be the basic thought behind the objections of those who most insistently demand the retention of the voluntary system as at present constituted. The spirit of charity

can still be retained under my suggested scheme, for it allows for the continued free treatment of the poor, of whom there will always be a sufficient supply to occupy the fullest amount of hospital space that the charitable are likely to provide. If, in any happy region, the charitable subscriptions exceeded the absolutely necessary demands upon them, the excess could well be applied to the reduction of the charges made to the paying patients. Further, charity does not begin and end with the apportionment of various sums of money to various specific objects. It can still be exercised in less tangible forms, and there will always be ample outlet for all the founts of charity that this world is likely to provide.

THE SUSSEX PROVIDENT SCHEME.

THERE is now at work in Brighton, Hove, and Preston, through the help and co-operation of the principal hospitals in those places, a provident scheme which supplies its members, under the conditions set out in the rules, with practically all the medical resources which exist at the present day in a large and highly organized community.

The chief consideration which led to the establishment of the scheme was a recognition that the great and increased cost and complexity of medical services, beyond the scope of a general practitioner, made it impossible for a large majority of the population to obtain benefits in cases which could not be properly dealt with unless the doctor in charge had them at his disposal. The patient was compelled either to do without the advantages or to accept them wholly or in part as a charity. A further fact which weighed with those who promoted the scheme was that many of the voluntary hospitals are already obliged to charge for their services; the Royal Sussex County Hospital, the principal hospital in Brighton, has, since January 1st, asked all its out-patients to pay a part of the outgoing cost of their treatment and its in-patients to contribute according to their means to their maintenance in hospital.

The scheme is designed to assist not only the hospitals but the general practitioner also, and has been very fully considered by the whole profession in the district; it has been approved by four meetings of the profession called to consider it—namely, by meetings of the Executive Committee of the Brighton Division of the British Medical Association, of the Brighton Panel Committee, of the honorary medical and surgical staffs of the hospitals concerned, and of the medical and dental professions generally.

It is clearly to be understood that the scheme has nothing whatever to do with the National Health Insurance or any other organization for medical benefit, and does not provide its members with ordinary medical—that is, general practitioner—attendance, or other benefit to which they are entitled from the State or from local authorities. It has been established for the benefit of those who, being bona fide residents of Sussex, irrespective of class or occupation, are in a financial position which makes them eligible for election as members.

All those insured under the National Health Insurance Acts are eligible for membership. While for others it has not been found possible to fix a hard and fast line of financial eligibility, a maximum income limit of £260 for single members, £400 for married people without children, or for a widow or widower with one child, and £500 for a family, may perhaps be assumed generally.

Facilities.

The following facilities have been arranged:

Consultations. The medical attendant of a member may arrange, by appointment, for private consultations at any of the co-operating hospitals, namely:

- The Royal Sussex County Hospital.
- The Royal Alexandra Hospital for Sick Children.
- The Brighton and Hove Hospital for Women (for Obstetrics and Gynaecology).
- The Brighton and Hove Provident Dental Hospital for Dental Surgery).
- The Brighton, Hove, and Preston Dispensary.
- The Sussex Eye Hospital (for Ophthalmic Cases).
- The Sussex Throat and Ear Hospital (for Diseases of the Throat, Nose, and Ear).
- The Lady Chichester Hospital (for borderland Mental Cases), and
- The New Sussex Hospital for Women and Children;

and such treatment as he and the consultant may jointly think advisable will be undertaken, at the hospital if this should be necessary.

For those members who are living in the county borough of Brighton and municipal borough of Hove, and unable to leave their beds, the services of visiting consultants (a list of whom will be kept at the office) may be secured by appointment. For country members unable to leave their beds free consultations may be obtained by appointment, subject to the payment to the consultant at the time of consultation of a charge equal to one-half of the usual mileage rates calculated from the Brighton Central Railway Station.

Dental Treatment. The Brighton and Hove Provident Dental Hospital will supply members sent by their medical attendant with all ordinary dental treatment which may be considered necessary, and will provide them with any dentures which may be required at hospital rates.

Laboratory. All the resources of the Stephen Ralli Memorial Laboratory, Royal Sussex County Hospital, will be available for the benefit of members after consultation, including bacteriological and pathological investigations and examinations beyond the province of general practice, Wassermann and Widal tests, etc., blood examinations and counts, the preparation of antigenous vaccines, etc.

X-ray examinations will be available at the Royal Sussex County Hospital and at the Western Branch of the Brighton, Hove and Preston Dispensary, at the request of the medical attendant of a member, and, where found necessary, will be made, and a report supplied to a doctor. Treatment by x rays (including bismuth meals with examinations) will be given when, after consultation, it has been considered advisable.

Massage will be provided by appointment for members in whose cases it is prescribed after consultation.

Electrical treatment—that is, galvanism, faradism, high-frequency, ionization, diathermy, etc.—will be administered by appointment at the Royal Sussex County and other hospitals, after consultation, in suitable cases.

Hospital Treatment.—Urgent cases will be admitted to hospitals as at present, other cases requiring operation or other hospital treatment will, after consultation, be admitted to hospital, or be placed upon the waiting list of the hospital until there is a vacant bed, but a member will not take precedence over more urgent cases, and the ordinary hospital routine will not be disturbed. In all the co-operating hospitals in which beds are reserved at present for paying patients, members will be admitted to these beds if available, should they desire it, at a uniform reduction of one guinea a week from the usual price of the bed.

RULES.

1. No one will be accepted as a single member except an unmarried man or woman, or a widower or widow without children under the age of 16. The subscription for a single member will be £1 per annum.
2. Married people without children, or a widower or widow with only one child under the age of 16 years, may only subscribe jointly at a rate of £1 10s. per annum for the two, although each shall be accounted a member.
3. Married people with a child or children under the age of 16, or a widower or widow with children under the age of 16 years, may only subscribe at a family rate of £2 per annum, which shall include the whole family, however large, except children over the age of 16, who must be accepted as single members, although each individual in the family shall be accounted a member. N.B.—These rates are subject to revision by the co-operating hospitals after due notice.
4. All candidates for membership must be approved by the "Committee of Reference" formed by the co-operating hospitals, except in the case of those insured under the National Health Insurance Acts, who will produce their medical card. In the event of the eligibility of any member being questioned, the matter will be submitted to the "Committee of Reference," whose decision shall be final.
5. Cards of membership, bearing the date, will be issued on the first day of each month, to those who have become members during the preceding month, and the benefits will begin on the date of the card, and continue for one calendar year. These cards can be produced as evidence of membership.
6. At the end of one year from the date of issue of the membership card the benefits will cease unless the subscription has been renewed. Fourteen days' grace will be given for renewal, during which no benefit will be available, but after this, renewed membership will only be possible from the beginning of the next quarter.
7. When the number of members has reached the limit of the capacity of the co-operative hospitals the list will be closed.
8. When a member is leaving the county within the next six months of membership, and in consequence wishes to resign, one-half of the subscription will be repayable upon application.

The first ten thousand members will receive an "original member's" card, and their subscription will not be raised while they continue to be members.

An office has been established at 4, St. George's Place, Brighton, where forms of application for membership are issued and subscriptions received.

At a general meeting of members of the Medical Society of Victoria, Dr. W. R. Boyd and Dr. J. H. Mollison were enthusiastically appointed life members of the society in recognition of many years' valuable services rendered by them to the society.

As a result of scientific investigations begun in 1914, improvements have been carried out at Harrogate, and the strength of the saline sulphur bathing waters has been doubled; the strength of the other sulphur bathing waters has also been increased. The Harlow Car alkaline sulphur water, which is used for skin diseases, has been brought in an efficient state to Harrogate from the springs over two miles distant.

British Medical Journal.

SATURDAY, JANUARY 22ND, 1921.

THE VACCINATION OF CATTLE AGAINST TUBERCULOSIS.

VARIOUS attempts have been made to render dairy cattle immune to tuberculosis, but without any great success. The most promising results were obtained by the use of attenuated strains of tubercle bacilli. For several years previous to the war Calmette and Guerin had been publishing studies in this line, but these never attracted the attention which they merited. In 1913 they showed that by cultivating the bovine tubercle bacillus, in a long series of successive passages on a potato medium treated with glycerin and ox-bile, they obtained an attenuated strain of bacilli not virulent for the ox, monkey, and guinea-pig, and well tolerated by the body, even when injected intravenously in considerable doses. In the case of cattle so treated a marked resistance to intravenous inoculation of ordinary tubercle bacilli developed a month after inoculation. Intravenous injection of 100 milligrams of the seventieth subculture into a calf produced a general reaction, from which the animal recovered spontaneously after fifteen to twenty days; in other words, the tubercle bacillus was so modified that it became non-tuberculigenic, though it remained capable of provoking abundant antibodies and agglutinins in the serum of the injected animal. Animals so treated were unaffected by intravenous injections of 3 milligrams of virulent bacilli.

The conditions under which dairy cattle live, however, and the way in which they naturally contract tuberculosis, prevented any confident conclusions from being drawn regarding the efficacy of the protective inoculation against naturally acquired tuberculosis. Calmette and Guerin, therefore, set about the investigation of this question towards the end of 1912, but their experiments were rudely interrupted by the German occupation of Lille, and the repressive measures adopted by the German authorities finally brought them to a close in the autumn of 1915; they were, however, only able to publish their results a short time ago.¹

They employed ten Breton heifers, from nine to ten months old, which were free from tuberculosis. Six of these were vaccinated with the living attenuated tubercle bacilli, and four were kept as controls. In November, 1912, the six heifers received into the jugular vein a single injection of 20 mg. (880 million) of bovine bacilli from a fortnight old culture of the seventieth generation on bile-potato medium. On that day all the heifers, inoculated and uninoculated, were placed in a cowshed specially arranged to favour natural contamination; this shed had already been occupied for two months by five tuberculous adult cows. In order to ensure contamination the tuberculous cows were stalled in front of the row of heifers and the floor of the shed was so inclined that the dejections of the former constantly soiled the bedding and the food of the latter. Some of the tuberculous cows died, but were replaced by others also tuberculous, so that there were always five infecting cows present;

altogether ten such cows died, in eight of which autopsy revealed the existence of advanced tuberculosis, and in the other two only a discrete tuberculosis of the bronchial and mediastinal glands. One of these last remained in the cowshed for a period of thirty-one months, so that the minimum effective infecting number may be put at three—all serious cases present at the same time.

A year after the beginning of the experiment the ten heifers were given an injection of tuberculin. The result of the test was that three out of the four controls reacted positively, and of the six vaccinated, one was positive, two were doubtful, and three were quite negative. But there is more in this than appears at first sight. It is quite permissible to conclude in favour of tuberculosis in the case of the untreated animals, but another factor has to be considered in the interpretation of the positive and doubtful reactions given by the vaccinated heifers. The latter may still harbour in their body the non-virulent bacilli incapable of producing lesions, but capable of rendering the body sensitive to the tuberculin. At any rate, all the ten heifers appeared to be in a satisfactory condition of health: they maintained their regular growth. Three of the vaccinated heifers then received a second intravenous injection of 2 mg. of a three-weeks-old culture of bacilli of the eighty-ninth generation in bile-potato medium. Six months later—that is, eighteen months after the commencement of the experiment—all the heifers were tested with tuberculin. On this occasion none of the six vaccinated animals reacted (even though some of them reacted previously), whilst three out of the four controls were manifestly infected. The remaining control seemed to be a case of natural resistance to infection. After a further period of six months two of the vaccinated heifers were again inoculated with attenuated bacilli. The health of the animals remained good. In the spring of 1915, two and a half years after the first vaccination, one of the treated heifers died through an accident; it had been vaccinated three times; autopsy revealed not the slightest trace of tuberculosis, nor did the injection of the triturated bronchial glands into guinea-pigs produce any lesions.

A tuberculin test made in the thirty-second month provoked no response in the two heifers which had been thrice vaccinated, and was quite negative also in another which had been twice vaccinated, whilst two of the three which had only been vaccinated once gave now a positive reaction. In these last the contamination must have occurred between the eighteenth and thirty-second months of infecting cohabitation. Owing to the nature of the German military regulations in Lille, most of the work had to be conducted with great secrecy, and finally the animals had to be slaughtered before the end of the third year was actually reached. Examination of the bodies showed that of the four unvaccinated heifers, three had developed tuberculous lesions and the fourth had proved quite resistant to contamination; two of the three which had been only once vaccinated showed lesions, the third being quite free; the animal which had been vaccinated twice was free from tuberculosis; and the two which had been vaccinated on three occasions showed no signs of the disease.

Calmette and Guerin conclude that the cultivation of bovine tubercle bacilli in successive series on their glycerin-bile-potato medium enables them to obtain a strain of non-tuberculigenic bacilli perfectly tolerated by cattle and other animals sensitive to the tubercle virus. Their strains have now been going on for thirteen years. This non-virulent race of tubercle bacilli

¹ Calmette and Guerin, *Annales de l'Institut Pasteur*, vol. xxxiv, No. 9, 1920.

acts as a true vaccine in the sense that when inoculated into the veins of cattle it confers on them a resistance not only against experimental inoculation but against contamination by direct cohabitation in infected cowsheds. They believe that this resistance is related to the actual presence of the non-virulent bacilli in the body, and that it does not persist for more than eighteen months as a rule, but that it may be indefinitely prolonged by annual revaccinations. It would of course be desirable that essays of this kind should be carried out on a much larger number of animals and over a number of years corresponding to the average duration of the life of cattle in order that more precise details of the actual value of the vaccination may be obtained.

It is interesting to learn that this living bovine vaccine is inoffensive for man, even by intravenous inoculation in doses of at least 44,000 bacilli. Professor Calmette, in a recent interview with *Le Petit Journal*, while deprecating any too sanguine expectations, expressed the opinion that the results of the experiments opened great possibilities for the future; it was proposed, he added, to make experiments with anthropoid apes, and in order that they might be conducted under the best conditions it would be necessary to have a suitable climate. This, it was believed, had been found in the islands of the Los archipelago, on the coast of French Guinea, West Africa. It is proposed to build a large experimental laboratory on one of these islands, and the Government of West Africa has placed the sum of 350,000 francs at the disposal of the laboratory; it is hoped that when the importance of the experiment is realized the public will subscribe liberally.

FATIGUE AND EFFICIENCY.

THE relation of hours of labour and methods of work to industrial efficiency and to the health and contentment of the workers is being widely studied, both by individual workers, such as Dr. C. S. Myers, and by investigators acting on behalf of the Industrial Fatigue Research Board. The series of reports published by the Board and noticed from time to time in our columns not only contain material of medical importance, but they show that careful systematic investigation of different industries by impartial men of science (who need not have special knowledge of the industry under examination) can bring to light errors in method or in administration which, if undisclosed and unsuspected, may injuriously affect the whole industry and breed discontent among the workpeople. The report on "Fatigue and Efficiency in the Iron and Steel Industry," by Dr. H. M. Vernon, is the latest of this series, and is a definite addition to the growing mass of information on the subject. The difficulty is to find a trustworthy index of fatigue. At present output, although it is affected by many other factors, forms the most convenient quantitative measure of the fatigue induced in an industrial worker by the pursuit of his calling. It may be impossible to devise a better test of the immediate effects of fatigue, but the more remote effects are sometimes suggested in an impressive manner by sickness and mortality records.

The fatigue may be muscular and relate to most of the body muscles, as in the blast-furnace barrowmen in the industry now reported upon, or it may relate to only a few small muscles, as is most strikingly evidenced in ergograph experiments. On the other hand,

it may be chiefly mental, as in some enginemen and crane-men who are seated all day, but who have to be for ever on the alert in order that they may manipulate their levers correctly. Or, again, it may be due to the trying effects of exposure to hot and moist air, as in certain textile processes. Another difficulty arises from the intermittency of many types of labour—for instance, the open-hearth steel-melters. On one shift they may have practically no work at all to do, and on the next shift they may have a long bout of excessively hot and heavy fettling. For these and other reasons it will always be a matter of extreme difficulty to compare quantitatively the fatigue induced by various types of manual labour. Nevertheless, it is of interest and importance to compare these types one with another, so far as may be found possible, and group various industries and branches of an industry according to the fatigue they usually induce.

The term "fatigue" must be taken in a general sense as implying a diminished capacity for work, whether this diminished capacity is muscular or mental in origin. The final and perhaps the most important test of the fatigue of a man's calling is to be found in the effect it has upon his health and length of life. This effect is likewise extremely difficult to estimate, for health is influenced by many factors, such as the environment in which the worker lives and the conditions under which he spent his childhood. In certain occupations, again, the health is undoubtedly affected by the inhalation of dust and by chemical poisons. Nevertheless, though it may not be possible, in many cases, to trace an excess of sickness or mortality definitely to the influence of fatigue, it is of great importance to estimate and compare the health of men engaged in different occupations. If the health is clearly proved to be below the average, further investigation ought to be undertaken to determine the cause of the disability.

In the investigation now before us, sickness records of about 20,000 steelworkers for six years were tabulated. The figures showed that on an average the men lost 6.5 days each year from all causes. The steel-melters and pitmen lost 23 per cent. more time than the average, the puddlers 20 per cent. more, the tinsplate millmen 12 per cent. more, and the rolling millmen 8 per cent. more. Almost all these men frequently work at high temperatures, whilst the engine and crane men and the other workers (largely labourers), who work as a rule at ordinary temperatures and on less heavy jobs, showed 8 or 9 per cent. less sickness than the average. The excess of sickness among the puddlers was due entirely to rheumatism and respiratory diseases: this, it is thought, may be attributed in part at least to their custom of alternating periods of heavy work with periods of rest or of light work, for the tinsplate millmen, who work almost continuously, showed no excess of sickness from these causes. Records of 1,000 blast-furnace men, tabulated for a six-year period, showed that the younger men lost one to two days more each year from sickness than the steel-workers, while the older men lost four days more.

In regard to mortality, steel workers aged 25 to 65 showed a 5 per cent. lower death rate than all males (occupied and retired); they showed 102 per cent. greater mortality from respiratory diseases, but 48 per cent. smaller mortality from tuberculosis (mainly phthisis). The steel-melters had a 20 per cent. greater mortality than all males, but the other men working at high temperatures and the engine and crane men had a smaller mortality; the blast-furnace men had a much higher mortality than the steel-workers, presumably because of their greater exposure

* Reports of the Industrial Fatigue Research Board. No. 5: Fatigue and Efficiency in the Iron and Steel Industry. London: H.M. Stationery Office. 3s. net.

to the weather. It is probable that all the records yield too low an estimate of death rate owing to withdrawals of some of the less vigorous men.

In some works there was a strange lack of provision for the comfort of the men; for instance, in one district where there are more than two hundred rainy days a year, men engaged in heavy work in the open had no cover whatever; but on the other hand, the men were sometimes more at fault than the employers, for in work where the workmen's shirts usually became wet through it was the exception for a man to keep a spare shirt. As in other forms of manual labour, output usually varied with the temperature; it was greatest in the winter months, intermediate in the spring and autumn, and least in the summer. Again, in different parts, output was affected by the enormous variations in the efficiency with which human labour was utilized and in the efficiency of the plant in the different works; if all the iron and steel works in the country adopted the most efficient methods, Dr. Vernon considers that they could, on an average, improve their output by something between 50 and 100 per cent. There is little doubt that increased output, as a direct result of the greater comfort and contentment of the workpeople, could be obtained by modifications, sometimes exceedingly slight but with a far-reaching effect, of the existing plant and the methods of work. In other industries the provision of suitable seating accommodation, appropriate foot rests, abolition of stooping, improved arrangement of parts used in the fitting up and turning out of complete articles, improvements in ventilation, lighting, noise, vibration, and temperature, have all been found to increase the efficiency of the work of the operatives. A uniform hour-by-hour yield is neither natural with human beings nor is it desirable; a man regulates his output according to his mental state and his conditions of work; hence a discontented mind inevitably leads to lessened production. Investigation in certain branches of the engineering trade showed that not only was efficiency distinctly greater, but the hourly output was almost always increased when the ten-hour day was reduced to an eight-hour day. Dr. Vernon, however, has found that it takes workpeople several months to settle into the new and shorter hours of labour before output and efficiency begin to improve. These and other kindred lessons are full of significance for those who are seeking to readjust the conditions of industrial employment.

SUSSEX PROVIDENT SCHEME.

THE medical provident scheme for Sussex, details of which are given at p. 129, is of very considerable interest, because it seeks to meet two of the difficulties encountered at the present time by the medical profession and by the voluntary hospitals. It is designed, on the one hand, to afford general practitioners all the facilities for their patients which hospitals and other existing medical institutions provide, and, on the other hand, to help the hospitals by providing them with a source of income which, if the scheme is as successful as is hoped, will materially improve their financial position. The Sussex scheme centres round the medical institutions in Brighton and Hove. The starting point seems to have been an announcement by the chief general hospital in Brighton—the Royal Sussex County Hospital—that it would in future require in-patients to contribute, according to their means, to the cost of their maintenance in hospital, and would charge out-patients the cost of their treatment. The question then immediately arose whether it would not be better policy from every

point of view that prospective patients of the hospital should furnish their contribution on a provident basis. The hospitals offer their buildings and organization; the ordinary routine of their work is not materially interfered with, and the institution and conduct of the scheme has not cost them anything; even had the number of members been very small, each hospital would still have benefited to the extent of its share of the fund. The subscription for a single member is £1 a year, and for married people with children under the age of 16 £2 a year, and so on; children over 16 must become single members, paying £1 a year. All insured persons are eligible for membership. People who are not insured persons must be approved by a committee of reference formed by the co-operating hospitals. The income limit it is proposed to fix is £260 for a single person, £400 for married people without children, or for a widow or widower with one child, and £500 for a family. At present subscriptions are annual, the whole amount being paid when the applicant is admitted to membership. This simplifies bookkeeping, but is not convenient to all weekly wage earners; consequently arrangements by which the subscriptions of persons employed at works may be deducted weekly by the employer, as is commonly done in many districts, are in contemplation. The scheme has been very fully considered and approved by the whole medical profession in the district, including the hospital staffs, private general practitioners, insurance practitioners, and the Executive Committee of the Brighton Division of the British Medical Association. Its most striking feature from the point of view of medical policy is that all the facilities for diagnosis, as well as for special treatment, afforded by the hospitals and other medical institutions of the towns, are put at the disposal of the general practitioner for the benefit of the provident members under his care. The detailed article to which reference has been made shows the various facilities for diagnosis and special treatment which will be available to members joining the provident scheme and reproduces also a copy of the rules which will be enforced. Consultations in the hospitals will entail some increased expenditure of time and trouble on the hospital staff, but we are informed that 25 per cent. of the money paid to the hospital will be placed at the disposal of the staff. It will be seen also that arrangements have been made for visits by consultants to the home of a patient unable to leave his bed. In the past a good many consultations have been given at reduced fees among people whose financial circumstances now make them eligible to be members of the provident scheme; it is hoped in future to be able to pay a full fee for each consultation. It is believed that such consultations are likely to become much more frequent, inasmuch as the doctor in attendance will no longer have to consider his patient's pocket in suggesting a second opinion. An office for the receipt of subscriptions and the issue of cards of membership has been opened in Brighton, under the general direction of the consultative committee of the provident scheme. The proportions in which the amount received in subscriptions shall be divided among the medical institutions has been determined, and a portion has been set aside for x-ray services and to pay the fees of visiting consultants. A portion is reserved also to defray the expenses of the office at which the business of the provident scheme is conducted, and for legal and auditing expenses. Any surplus will, in the light of the year's working, be allotted to one or more of the co-operating institutions on the recommendation of the joint meeting of the committee of reference of the hospitals and the consultative committee of the provident scheme. As has been said, the scheme is of great interest to the medical profession and to all concerned to maintain the voluntary hospitals. The possibility of adapting it to even so large an area as London is under consideration by some of the hospitals—among others, we believe, the London Hospital and St. Thomas's.

Whether it could be applied to separate districts of London, or whether London should be treated as a single unit, will require very careful consideration before any attempt is made to put a scheme in force.

THE UNIVERSITY OF LONDON'S PHYSIOLOGICAL LABORATORY.

At its meeting last month the Senate of the University of London decided that the physiological laboratory must be closed at the end of July next unless assurance of adequate support is received from the London County Council or other sources before the end of March. The laboratory was established under the direction of Professor A. D. Waller, F.R.S., in 1902, at the headquarters of the University in the Imperial Institute, South Kensington, the equipment being provided out of a fund of £4,000 provided from private sources. It has since been maintained partly out of university funds and partly by private assistance, with the help, during the last nine years, of an annual grant of £500 from the London County Council. This grant is now to be withdrawn, and the University has no funds out of which to make up the deficit. In deciding to close the laboratory, the Senate appears to be influenced also by the need of finding additional room in its present quarters for general university purposes; this is indicated by a further resolution stating "that should adequate support for the transference and maintenance of the physiological laboratory be forthcoming, the laboratory be continued during the pleasure of the Senate elsewhere than in its present quarters, which shall be vacated not later than the end of July, 1921." Physiologists will agree with Sir E. Sharpey Schafer that the closure of the laboratory would be a serious misfortune. "It is," he says, in a letter to the *Times*, "unique from the fact that, being unattached to any particular medical school or college, it has been untrammelled by the necessity of providing elementary teaching in physiology, and has been able to devote all its energies to research. The success it has obtained in this under the able guidance of the director, Professor A. D. Waller, is universally acknowledged. The originality of Professor Waller's methods and the brilliant results which have been obtained from their application—especially in the difficult subject of electrophysiology—are well known. It would be a real calamity if a sudden stop were put to these activities." It is suggested that the reason why the London County Council has withdrawn its contribution at this time is the expectation that it will shortly have to contribute a large sum toward the cost of building new university headquarters. "It would seem," Sir E. Sharpey Schafer concludes, "a pity to allow an active laboratory to be abolished in order to save £500 a year towards the cost of problematical buildings." "Problematical," perhaps, is not quite the right word, because, we presume, something will have to be done for the University, but no building can be undertaken for some considerable time to come. We can only express the hope that, should the London County Council remain obdurate, public-spirited benefactors, recognizing the importance of the University having at least one research laboratory, will come to the rescue. We may, at any rate, express the expectation that means will be found to carry on the laboratory until the question of the new site for the University is settled.

THE FINE CHEMICAL INDUSTRY.

THE Society of Chemical Industry has issued a reprint of a paper on the present position of the fine chemical industry which lately appeared in its *Review*. "Fine chemicals" is a term not always understood, and includes not only dyes but the important groups of laboratory chemicals (that is, analytical reagents and research chemicals), pharmaceutical chemicals, and photographic chemicals. The writer of the paper, Mr. C. A. Hill, pleads for the protection of all the fine chemical industries in this

country, on the ground that they are "key" industries, that in spite of much enterprise they are not as yet fully stabilized, and that the Sankey judgement, which has led to "the swamping of the market with German goods," threatens to defeat the best efforts of the British manufacturer. He looks for an extension to fine chemicals generally of the protection recently granted to the dyes industry—that is to say, prohibition of imports except under a system of licences, such licences to be readily granted when British manufacturers are unable to meet genuine demands for essential products. Mr. Hill, of course, puts forward only one point of view, and dismisses, perhaps too summarily, the advantage of reduced cost of medicinal substances under free importation; he describes such reduction as small, problematical, and temporary. But no doubt he voices the general feeling of the manufacturers of fine chemicals, and at least he will not be challenged when he urges that the expansion of an organic chemical industry is intimately associated with developments in biochemistry and therapeutics.

THE ARMY DENTAL CORPS.

A ROYAL WARRANT dated January 4th, 1921, has just been issued as an Army Order, authorizing the formation of a corps to be entitled the Army Dental Corps. The conditions of service and promotion, the rates of pay and half-pay, and the rates and conditions of retired pay and gratuity, are set out in a schedule attached to the Warrant. The Army Dental Corps will be administered by the Director-General, Army Medical Service. It is a joint service for the Army and the Royal Air Force; the personnel will be required to serve under either force, and will be interchangeable; promotion will be carried out on one general list. Commissions as lieutenants may be given to persons duly qualified under regulations approved by the Army Council. Officers will be eligible for promotion to captain on completion of three and a half years' service in the corps; promotion to major and lieutenant-colonel to fill the establishments laid down will be made by selection from among those qualified for promotion. On the formation of the corps certain appointments will be made in the rank of lieutenant-colonel and major to fill the establishments; the remainder of the appointments will be in the rank of lieutenant, except that captain's rank will be given to those who have served three and a half years or more as temporary dental officers. Service as a temporary dental officer will count towards the three and a half years' service for promotion to captain. The daily rates of pay for officers of the corps are: Lieutenants, £1; captains, £1 5s. to £1 8s. 6d.; majors, £1 13s. to £1 18s.; lieutenant-colonels, £2 7s. 6d., rising to £2 12s. 6d. The rates of retired pay will be the same as for officers of the R.A.M.C. Retirement will be compulsory at the age of 55.

QUACK PSYCHO-ANALYSIS.

IT appears that psycho-analysis, hitherto cultivated by a certain number of medical practitioners and trained psychologists, has already become a fashionable craze, and whatsoever of good there may be in it is in peril of meeting the fate that befell hypnotism many years ago. It was seized upon at an early stage by some novelists in search of a new plot; this, perhaps, did not matter much, but it is said that every sort of charlatan, crystal-gazer, palmist, and clairvoyant, is now picking up a smattering of the catchwords of psychology, and in particular of the terminology coined by Freud and his disciples, with the intention of exploiting the popular taste for dabbling in psychology, and of preying upon the neurotic section of the public. The neuropath who has heard and read about the marvels of psycho-analysis may become an easy victim to the advertisements of quack psycho-analysts. According to the *Daily Graphic*, which is doing a public service by its exposures, this kind of quack has sprung up, mushroom-like, of late in London and in other cities and towns. For

a fee varying from half a guinea to ten, twenty, or even fifty guineas, according to the gullibility of the patient, wonderful "cures" are said to be promised. It needs little imagination to see that there must be possibilities of blackmail in this new phase of quackery. The police have been active in suppressing the professional fortune-tellers; it would be tragic if by so doing they have helped to turn such parasites to dangerous practices again, now that their old method of exploiting the credulous has been so parodied as to have been rendered comparatively harmless. Ventilation in the lay press may, however, avert the evil. In the meanwhile the injury to the genuine study and practice of psychological analysis must be considerable.

INSTRUCTION OF MEDICAL STUDENTS IN PHYSICS.

THERE is little doubt that the medical student finds the early part of his studies the least interesting, and mainly because he fails to see the practical application to his future work of much that he is taught at the outset, and that this applies more to physics than to biology or even chemistry. This drawback, partly inherent in the subject, which is so largely based on mathematics, a science that appeals to a type of mind rare in medical men, can to some extent be overcome by the manner in which the subject is presented by the teacher. It is therefore interesting to hear the experience of Professor Marcel Dufour¹ of the Faculty of Medicine of Algiers, who has taught medical students for a quarter of a century, on the best method of instructing them in medical physics. In the first place he points out that the physics course should be essentially practical, and consist as far as possible of demonstrations; for, with rare exceptions, medical students are attracted only by what they can see and tend to forget everything else; abstract reasoning does not appeal to them, and mathematics repels them. The problems of medical physics are not quite the same as those of ordinary physics; they are more complex; thus the laws of optics require some modifications when applied to the eye, and the methods of estimating arterial blood pressure and of the electrical testing of muscles and nerves differ from those employed by a physicist in taking a record of the pressure of fluid in a reservoir or of the resistance of a copper wire. These differences should be explained, and the instruments of precision employed in clinical practice should be fully explained by the lecturer on medical physics. The importance of pointing out the practical bearing of physics on medical problems is insisted on, and Professor Dufour recommends that the instruction in medical optics should be given in the ophthalmic clinic, and in medical electricity in the electrical and x-ray departments. Lastly, in order to maintain attention and ensure that the students really understand what they are being taught, it is advisable that the demonstrations should be interspersed with questions.

WOMEN ON JURIES.

THE daily papers are making frequent references to the service of women on juries. It is pointed out that here "Mr. A. B. objected to all the women jurors," or that there "Mrs. C. D. objected to serving on the jury because she felt nervous." This is the kind of information which must, we suppose, prove attractive to the public, or it would not be given; but in the meantime what is the position? The mixed jury is an accomplished fact. Whether the women summoned to attend are very grateful to those who so strenuously fought for women's rights may be open to question, but so far as can be judged from the experience of quarter sessions, the presence of a few women on the jury makes little or no difference to the administration of justice. One of the chief objections to the service of women in this capacity has been that they must inevitably be called upon to try cases of an unpleasant nature. This is, of course, true; there are

certain types of case, all too common in our criminal courts, to which no women should be forced to listen. But in the ordinary case, say, of indecent assault, it is often necessary to examine and cross-examine a woman upon all the revolting details in the presence of a jury of men. To have a few women on the jury should ease the situation, nor is there anything so very novel in a jury of women. It is stated in a well known book on the criminal law that in England when a woman is convicted and sentenced to death, the clerk of the court, after sentence, is to ask whether the woman has anything to say in stay of execution of the sentence. If she then alleges, or the court then or later has reason to suppose that she is pregnant, a jury of twelve matrons should be empanelled and sworn to try whether or not she is quick with child. "The jury," according to *Archbold's Criminal Pleading*, "may be empanelled forthwith, *de mulieribus circumstantibus*, the judge first ordering that all the doors be shut and that no one be allowed to leave the court." Should the matrons desire the assistance of a medical man, a medical man is requested by the court to retire and examine the prisoner. When his examination is concluded the jury of matrons is recalled into court, and his evidence is given in their presence and that of the prisoner. If they find the person quick with child, the court stays execution of the capital sentence on the offender until she shall be delivered of a child or it is no longer possible in the course of nature that she should be so delivered.

A SITE FOR THE UNIVERSITY OF LONDON.

A NEW turn has been given to the discussion about the site for the headquarters of the University of London by the suggestion that Holland Park would be suitable. The park is about a mile from the Imperial Institute, where the University's headquarters are now housed; it covers altogether an area of about 60 acres, and about 35 acres would, it is understood, be immediately available. It is not traversed by public roads, so that the area could be laid out as a whole. The site offered by the Government in Bloomsbury contains 11½ acres, but it is cut up by roads into four plots, affording a total building area of about 8½ acres. The present tenant for life of Holland Park, Lady Ilchester, has stated that the much larger area which could immediately be made available there for building would cost much less than the £400,000 mentioned as the price of the Bloomsbury site. The suggestion appears to have the support of the London County Council, since it was put forward by Captain Swinton, a former chairman, and is supported by Colonel Levita, a member of its Education Committee. The Council is concerned in the matter because it is understood to be willing—following the example of the councils of many great provincial cities, such as Birmingham, Liverpool, Manchester and Sheffield—to help the University with money. The London County Council has not disagreed with the proposal to accept the Bloomsbury site, but it is not bound to it. Should the site be accepted by the Senate of the University the London County Council has undertaken to contribute not more than one-third of the contribution made by the Government in respect of expenditure not exceeding one million. Technically the decision as to the site rests with the Senate of the University, but obviously, as it has no large funds for building, it must be influenced by the action of the London County Council, as well as that of the Government. The Government has so far definitely refused to contribute to the cost of building. It seems very desirable that both the Senate and the London County Council should reconsider the position in view of the suggestion to acquire Holland Park or some part of it. That site is a good deal further west, and no doubt the centre of London has during the last hundred years ceased to move west, but a roomy site would go far to compensate for any disadvantages of this nature. As has been said,

¹M. Dufour: *Rev. générale des sciences pures et appliquées*. Paris, 1920, xxxi, 781.

Holland Park is only about a mile west of the present headquarters of the University, of the Natural History department of the British Museum, and of the Imperial College, though that great institution does not at present wish to become part of the University.

THE PRINCE OF WALES.

THE PRINCE OF WALES, who was elected an honorary Fellow of the Royal College of Surgeons of England last July, will attend the Hunterian Festival dinner on February 14th and receive the diploma of honorary fellowship from the President, Sir Anthony Bowby. In becoming an honorary Fellow of the College the Prince of Wales follows in the footsteps of his grandfather and father. King Edward VII when Prince of Wales was elected an honorary Fellow in June, 1900, and admitted in the following month, shortly before the centenary celebrations, which he attended. King George V, when Prince of Wales, was elected an honorary Fellow in February, 1909. The Duke of Connaught, who is now in India, was elected an honorary Fellow on the same day, July 24th, 1919, as the present Prince of Wales. The only other surviving honorary Fellow who does not belong to the medical profession is the Earl of Rosebery, who was admitted in 1900. There have been two other such honorary Fellows—namely, the Marquis of Salisbury, who was Prime Minister at the time the centenary was celebrated, and Field-Marshal Earl Roberts, who was elected in 1901.

THE TRANSFER OF SANATORIUM BENEFIT.

It will come as a surprise to many persons to learn that the Scottish public health authorities have been able to take over the provision and administration of sanatorium benefit in their areas from January 1st, seeing that Dr. Addison has found it necessary to postpone until May 1st the transfer of similar provisions from the English and Welsh Insurance Committees to the English and Welsh County Councils. The official communication issued by the Scottish Board of Health, which is given on page 23 of the SUPPLEMENT this week, states exactly what is occurring, but does not explain the difference in the circumstances which enables that body to go forward while the English Ministry of Health has to delay action for a period of four months. It appears that in its former capacity as the Scottish Local Government Board the Scottish Board of Health obtained, under an Act of Parliament passed years before the Insurance Act came into being, powers to secure the notification of tuberculosis, and to sanction the provision of sanatoriums by local authorities. When the National Insurance scheme was set up these powers were curtailed in order that they should be exercised for insured persons by the Insurance Committees. Last June, when the Public Health Amending Act was placed on the statute book, it was laid down for the United Kingdom that the Insurance Committees should not continue to deal with sanatorium benefit, but that the work should be undertaken by county councils. As regards Great Britain and Wales, however, the Act made further legislation necessary in order to enable county councils to fulfil this duty. Dr. Addison expected to be able to complete the transfer by means of the Tuberculosis Bill, but owing to the pressure of other Government business that measure had to be abandoned for the session, and with it the intention of effecting the change on January 1st. In the autumn, having no reason then to anticipate difficulty, he had informed the authorities in England and Wales of the proposed change, and the Scottish Ministry of Health did the same. But as the legislative authority for giving the new powers to English and Welsh county councils was not obtained he had to notify the English and Welsh authorities that action would be postponed until May 1st, 1921, by which date a Tuberculosis Bill would become law. The Scottish Board

of Health not being in this difficulty decided to let the notification stand, and that is how it happens that the Scottish health authorities have already taken over the arrangements for sanatorium benefit in Scotland.

HOSPITAL INQUIRY COMMITTEE.

WE are now able to confirm the statement made in our last issue that Viscount Cave would be chairman of the committee appointed by the Minister of Health with the following terms of reference: "To consider the present financial position of the voluntary hospitals and to make recommendations as to any action which should be taken to assist them." Sir Clarendon Hyde, Mr. R. C. Norman, and Mr. Vernon Hartshorn have also been appointed members. A representative for Scotland will be added, and it is proposed also to include a chartered accountant of high standing. The secretary of the committee is Mr. L. G. Brock, C.B., Assistant Secretary in the Ministry of Health, to whom all communications should be addressed at the Ministry of Health, Whitehall, London, S.W.

THE KING has approved the appointment of Mr. S. P. Vivian, a Principal Assistant Secretary in the Ministry of Health and Deputy Registrar-General, to be Registrar-General in succession to Sir Bernard Mallet, K.C.B.

At a special meeting of the governors of the Royal Chest Hospital held at the Mansion House on January 17th, it was resolved, as foreshadowed in our last issue at p. 96, to extinguish that institution as a separate entity, and to merge its special work in that of the Great Northern Central Hospital.

Scotland.

THE Secretary for Scotland has appointed Dr. G. H. R. Gibson, D.S.O., Croix de Guerre, to be Deputy Commissioner of the General Board of Control in Scotland.

ORTHOPAEDIC TEACHING IN EDINBURGH.

A proposal is under consideration in the University of Edinburgh for the establishment of a department of orthopaedics, and Sir Robert Jones devoted his Cameron lecture, delivered before the university on January 14th, to a consideration of the necessity of orthopaedics and its relation to the prevention and cure of deformity. The chair was taken by Professor Lorrain Smith, Dean of the Faculty of Medicine, and the large anatomy lecture theatre was crowded. The Cameron prize was founded in 1878 by the late Dr. Andrew Robertson Cameron, of Richmond, New South Wales, and the income, which, after defraying expenses, amounts to £150, may be awarded annually to a person who in the course of the five years immediately preceding has made any highly important and valuable addition to practical therapeutics. The first award under the present regulations was made in 1898, when M. Pasteur was the recipient. In the following years it was awarded to Lord Lister, Sir David Ferrier, Sir Victor Horsley, Professor Behring, Sir William Macewen, Sir Thomas R. Fraser, Dr. S. Monckton Copeman, Sir David Bruce, Mr. W. Haflkine, Sir Patrick Manson, Sir Ronald Ross, Professor Finsen, Professor August Bier, Dr. Simon Flexner, and Professor Paul Ehrlich. The last award was made in 1915 to Sir Lauder Brunton, in recognition of his researches in pharmacology and their application to therapeutics. The Chairman said that Sir Robert Jones had decided to present the amount awarded to him as a prize for orthopaedics in the University of Edinburgh. After the delivery of the lecture, which will be published shortly in full, a vote of thanks to Sir Robert Jones was moved by Sir Harold Stiles, professor of clinical surgery in the university, who expressed the hope that before long there would be established in that great imperial university a department of orthopaedics worthy of it.

NEW REGISTRAR-GENERAL FOR SCOTLAND.

Dr. James Craufurd Dunlop, F.R.C.P.Ed., Superintendent of Statistics in the Registrar-General's Department, Edinburgh, has been appointed by the Secretary of Scotland to the post of Registrar-General for births, deaths and marriages in Scotland. In addition to his many years' service in the General Register House, Dr. Dunlop has been Inspector under the Inebriates Act for Scotland and assistant adviser on the Prison Commission for Scotland. He was a member of the Royal Commission on the Care and Control of the Feeble-minded. In his official capacity he was closely concerned with the taking of the last census in 1911.

India.

SUBASSISTANT SURGEONS.

The fifteenth All-India Subassistant Surgeons' Conference was held in Delhi in December, 1920. The Chairman of the Reception Committee gave an account of the grievances under which the subassistant surgeons labour, laying special stress on the low pay, the increase of the medical course to five years, and the failure of the Lovett Committee to meet the desires of the service. The Director-General I.M.S. was elected Chairman of the Conference, and in a short opening address expressed his full sympathy with the aspirations of the subassistant surgeons. The value of their work, he said, was fully recognized by the Government of India. He said that in his view a five years' course of education was desirable. At present, subassistant surgeons filled many posts which the provinces could not afford to fill with assistant surgeons or subassistant surgeons who had taken out a five years' curriculum. This, so far as he knew, was the only excuse for having two grades of qualified men in India. While it was not possible to prophesy what would happen under the reforms scheme, he thought it certain that the class of medical men willing to accept a small salary would continue to be in demand for the smaller dispensaries. With regard to pay, he reminded his hearers that it had been improved during the war, and added that a further increase was under consideration. More doctors were wanted in India, but the need was in the country districts and not in the towns, where there were too many. Country dwellers were too poor to pay fees, and the provincial governments therefore maintained dispensaries; there was generally no difficulty in finding applicants for the medical posts. Afterwards the Viceroy opened the exhibition of sanitary and scientific appliances and indigenous drugs. In doing so, he referred particularly to the infant welfare section of the exhibition, and spoke in high praise of the excellent work unobtrusively done by the subassistant surgeons.

A DENTAL SCHOOL IN BOMBAY.

The Government of Bombay have submitted proposals for the establishment of a dental school and infirmary in Bombay, and inquiries are proceeding on the Continent and in America as to the best means of making a start. Meanwhile teachers in dentistry have been appointed in the Grant Medical College and three medical schools in the Presidency. When the dental school becomes established, the College of Physicians and Surgeons of Bombay will institute a registrable qualification in dentistry.

CENTRAL BOARD OF HEALTH.

A medical conference held in Simla in May, 1919, recommended the creation of a Central Imperial Board of Health for India, the appointment of a Director of Medical Research, and the establishment of an epidemiological statistical office. The Government of India decided to act upon these recommendations, and the plan, having received the sanction of the Secretary of State, will shortly come into force. The epidemiological office will be under the direction of the epidemiological statistician, who will be assisted by a body of expert statisticians. The Central Board will advise the Government of India and local governments on hygienic matters. The duty of the director of medical research will be to co-ordinate the work carried on by the Research Fund Association and the research work undertaken by the Government of India directly.

Correspondence.

RESUSCITATION OF THE APPARENTLY DEAD
AND THE RELATION OF CARDIAC
INNERVATION TO IT.

SIR,—The series of papers and notes which have recently appeared in the BRITISH MEDICAL JOURNAL on the resuscitation of the apparently dead have not only a practical but also a scientific interest. No situation with which the practitioner can be faced calls for more calm and prompt action than the sudden and unexpected cardiac failure with which he has at times to deal. Arising as this condition does, occasionally, under apparently trivial provocation, there is also no situation which may be more important for patient and practitioner alike. The patient may tragically lose his life and the practitioner be placed in a very unenviable position, which, in the event of a fatal issue, may require all his philosophy, and the intelligence and charity of his neighbours, to face with composure.

More than thirty years ago, when a general practitioner in the north of London, I was asked to visit a man who was about 40 years of age, but too grizzled for his years, and who had been suffering for ten days from tonsillitis. He had taken little food and had had no medical attendance. His wife, who alone nursed him, was far advanced in pregnancy. On examination I found he had some pus in one of his tonsils, and asked him to sit on the edge of his bed while I punctured the gland. On the first touch of the lancet he fell back on his bed apparently dead. Pulse and respiration ceased and the pupils became widely dilated and motionless, as one always observes at the moment of death. I believed him to be dead and thought there was little prospect of reviving him. I conducted his wife out of the room to another part of the house, fearing the effect upon her, in her condition, of the discovery of her husband's sudden death, and asked her to remain there till I returned.

On going back to the patient I found him in the condition in which I had left him—motionless, breathless, pulseless, with the same dilated and fixed pupils—in short, apparently dead. After artificial respiration for a time, with firm expiratory compression of the thorax, a single natural respiration occurred, and later another and yet another, until respiration and circulation were restored. I made him comfortable in bed, announced his satisfactory condition to his wife, who returned with me to the bedroom, and neither he, who lived for many years afterwards, nor she, was ever aware of the *mauvaise quarte d'heure* I had spent with the apparent corpse.

The ailment in this case was comparatively trifling; the patient was exhausted by voluntary abstinence from food, and the pricked tonsil sufficed to induce a cardiac standstill. Shock arising in any quarter may, under such circumstances, induce a profound cardiac inhibition or failure, but the tonsils, palatine and pharyngeal, from the special innervation of these parts (vago-glossopharyngeal), probably render them more intimately related to the heart and more easily provocative of such an accident as I have described. Indeed, it is probable that some disasters in the removal of tonsils and adenoids ascribed to the so-called status lymphaticus are really due to neural inhibition of the drugged heart. Laborde's method for the resuscitation of the apparently dead by tongue traction, which has been successfully used both in the newly born and in other conditions, points to this cardio-pharyngeal nerve relation as important under these circumstances.

The case I have mentioned resembles in a measure the third quoted by Dr. Cranston Walker (p. 47). While I do not agree with him that the nature of the syncopal attack can properly be termed a Stokes-Adams seizure, for the ventricle is innervated independently of the excitatory system and may be inhibited by vagal pressure when the auricles fail to be so, the result of artificial respiration was, in his case, also favourable.

A distinction must be drawn between the sudden onset of apparent death in those who are under the influence of an anaesthetic and in those who are not. The reflexes of the latter are, naturally, more sensitive than those of the former. It is the anaesthetized who will most frequently require laparotomy and cardiac massage when the heart fails, and, fortunately, under these circumstances, you've got the man, you've got the knife, and you've got the adrenalin too. As Mr. Fisher states (BRITISH MEDICAL JOURNAL, November 6th, 1920, p. 698), the laparotomy necessary to allow cardiac massage is an easier operation than tracheotomy, which all practitioners are assumed to be capable of performing. It must be remembered, however, that many cases of cardiac failure under an anaes-

betic may be resuscitated by artificial respiration, to which, I think, tongue traction should be added more frequently than it is. Experience, however, suggests that one should, even in trivial procedures such as those I have mentioned, be prepared with some local anaesthetic and the adrenalin syringe in case of accident. Mr. Fisher's article has both practical and theoretical interest, and the same may be said of Professor Gunn's contribution (BRITISH MEDICAL JOURNAL, January 1st, p. 9). Both these gentlemen and Dr. Walker refer to the relation of the cardiac nervous system to the conditions they deal with and to the means they employ in its treatment, while Professor Gunn has experimentally shown and explained the value, not only of adrenalin, but also of atropine, under the circumstances in question.

It is within quite recent memory that such emphasizing of the cardiac innervation was out of vogue, and that those who dwelt on its importance in cardiac action were considered as merely exposing their own archaicism. Even now there are those who only concede some modification of their purely myogenic conceptions with reluctance. It is, however, the case that to-day most writers describe the excitatory system as "neuro-muscular," and even the pacemaker, as I have shown (*Journal of Anatomy and Physiology*, July, 1912), is abundantly innervated, and therefore under nerve control.

The future also holds some modification of prevalent notions of the sensory element in cardiac neurology. When the conditions and circumstances in which sensibility in the autonomic system manifests itself are better understood, we may expect a change in conceptions of the nature and expression of visceral pain, including angina pectoris, at present entertained by some "authorities." Cannon and Washburn's demonstration (*American Journal of Physiology*, vol. xxix, p. 441) of the relation of hunger pains to gastric contraction is a useful contribution in this direction.—I am, etc.,

London, W., Jan. 12th. ALEXANDER BLACKHALL-MORISON.

ADRENALIN IN RESUSCITATION.

SIR,—In your issue of January 8th Dr. Cranston Walker raises a point of great therapeutic importance. Some years ago, in a desperate case of heart failure during chloroform anaesthesia, when my assistant was about to inject strychnine hypodermically into the precordium, the idea suddenly struck me to plunge the needle directly into the heart apex. Since then I have adopted this plan on at least six or eight occasions, and, like Dr. Cranston Walker, I have had varying results. All except two of the cases occurred in France, wherefore I have no records.

A few weeks ago Dr. D. H. Fraser anaesthetized a boy of 11 with ethyl chloride, in order that I might remove his tonsils with the reversed guillotinc. Apparently all went well, as regards both the anaesthetic and operation. But immediately following the latter, and less than a minute after its commencement, heart beat and respiration ceased (I am unable to say which failed first). All the ordinary means of resuscitation proved useless; the boy was seemingly dead. At my request Dr. Fraser gave 5 minims of liquor strychninae directly into the heart muscle. In a quarter of a minute or less the heart-beat, and almost immediately the respirations, recommenced. On regaining consciousness the patient complained of most violent and distressing precordial pain. It was surmised that the needle might have punctured a large branch of a coronary vessel; but there were no signs of haemopericardium. The spasms of pain passed off gradually, and next day he was well.

In his commentary on his third case Dr. Cranston Walker, with great fairness, points out that had adrenalin been available a little sooner it would have received undeserved credit for a resuscitation which actually occurred without the intervention of the drug. I would like to go further—and this is my point in the present letter—and say that, at any rate when using strychnine in my cases, it is debatable whether the drug has played any part. On each of the several occasions I have remarked in the theatre that the stimulus was probably mechanical—the prick of the needle rather than the action of the drug. This view may find support in the case above referred to, in which the persistence of anginal pain for several hours without physical signs suggested that the heart had received a deep and brisk prick. In the absence of proof

it is well to give the drug the benefit of the doubt; and since, on physiological grounds, adrenalin may be more effective than strychnine, I shall, since reading Dr. Cranston Walker's interesting article, use adrenalin on any future occasion.—I am, etc.,

London, W., Jan. 11th.

H. LAWSON WHALE.

SIR,—In connexion with the use of adrenin preparations for reviving the heart, the possibility of an overdose should be borne in mind. Adrenin exerts a depressor as well as an augmentor action on the heart, but when employed in small concentrations the depressor action is negligible. I have, however, observed that depressor action at a concentration of 1 in 250,000, and found it greater in hearts that were beating feebly than in hearts beating strongly. Hence I would suggest that a concentration, as suggested by Mr. Lockhart-Mummery, of 1 in 50,000 might be too great; 1 in 500,000 would be as effective and safer.

I have also found that the stimulating action of adrenin outlasts its actual presence in the medium by which it is conveyed to the heart, and that this property can be utilized experimentally to obtain augmentation only. A drop of adrenin is placed in the perfusing fluid and simply washed through the heart. Such conditions might be paralleled by injecting adrenin into the heart cavity and then expelling it by massage. The depressor action would accompany the adrenin, but the augmenting action would remain.—I am, etc.,

W. BURRIDGE, M.B.

The Physiological Laboratory, University of London, South Kensington, Jan. 15th.

SIR,—Few clinicians appear to know that acupuncture of any part of the cardiac muscle—the right auricle having been proved to be the most excitable region in man—produces powerful cardiac contractions. How, then, are we to decide whether the adrenalin or the acupuncture was the remedial agent in Dr. Cranston Walker's cases? In all cases in which cardiac massage is contemplated we ought first to try simple acupuncture of the muscle of the right auricle.—I am, etc.,

London, N.W., Jan. 12th.

LEONARD J. KIDD.

THE VOLUNTARY PRINCIPLE AND THE BRADFORD BOGEY.

SIR,—Your issue of January 15th has a letter from Mr. J. Basil Hall, of Bradford, on the voluntary principle of hospitals, which is so little helpful towards the elucidation of a difficult problem, that I should not have troubled to reply to it, but that its pointed references to myself might make some of your readers think that I ought to answer it. It, also, I refrained from doing so, as on first reading it was my intention, it might appear that it seriously invalidated the position I took up at the recent conference of staffs of voluntary hospitals, that the voluntary principle was becoming, if it had not already become, obsolete.

In the last paragraph of Mr. Hall's letter—about one-seventh of the whole letter—is contained a contribution to the subject which may be of value. The bulk of the rest of his letter is concerned with my own shortcomings, and in it Mr. Hall seems to have had in mind the advice of a famous barrister: "When you have a bad case, abuse the plaintiff's attorney." I use the word "abuse" in a technical sense only, as I do not wish to imply that Mr. Hall has transgressed the limits of courteous controversy in any way.

Mr. Hall starts by the somewhat bold assertion that "nearly everything that has been said about Bradford up to the present time is more or less untrue." I have no means of knowing "nearly everything that has been said about Bradford"; to claim such knowledge would be to make a claim to omniscience, which I personally would not wish to make, and which I doubt if Mr. Hall himself means to make. I suspect that what Mr. Hall means is that some of what has been written about the Bradford hospitals is inaccurate; and this can be readily granted. In fact, Mr. Hall proceeds to demonstrate the truth of this to the maximum amount possible in the comparatively short space of most of the rest of his letter.

He states that it is untrue "that no poor patient can get admission to the Royal Infirmary unless he pays a fee to a member of the honorary staff," and he then proceeds to say that "it appears that Dr. Peter Macdonald of York repeated the Bradford story . . . a story which is just so much propaganda to promote a general socialistic hospital policy throughout the kingdom." Mr. Hall is mistaken. I made no such statement and I repeated no such statement. I was aware of the statement and I did not credit it.

Mr. Hall then proceeds to traverse my illustration from the Bradford case, of the inadequacy of hospital supply by voluntarism. I said that Bradford voluntary hospitals had 361 beds and supplied a population "which cannot be less than half a million." Mr. Hall says the Bradford population is something nearly approaching 300,000. What has this got to do with it? The estimated population of Bradford is, for 1920, 295,636. The population of greater Bradford, if the projected extension of the municipal boundary goes through, will be 374,943; and the original proposals for extension would have made it about 420,000. But does Mr. Hall mean to imply that no patients come to the Bradford hospitals from outside the city boundaries, or any proposed city boundaries? Whatever Mr. Hall's capabilities as a controversialist may be, I know that his professional skill is such that he attracts a clientèle of patients from far outside the city boundary, and so do his colleagues; and one of the Bradford voluntary hospitals is the Eye and Ear Hospital, and its clientèle is drawn from a population which I am convinced is nearer a million than half a million.

The radius of twenty miles round the city of Bradford, in which Mr. Hall says that there are a score of hospitals, contains a population of at least two millions. I adhere to my estimate of half a million, and I believe it is not far wrong.

But what if it were? Does Mr. Hall consider 361 beds as providing adequate hospital accommodation for a population of 300,000, with the increasing appreciation by people of all classes of life that hospitals and nursing homes are the right places to treat illness, and that houses built to live in are not the best places to be ill in? Mr. Hall's words give the impression that he means this; but he surely does himself an injustice.

Mr. Hall proceeds to denounce the character of the buildings of the Bradford Municipal Hospital. I do not know these well. My knowledge of them is derived from a hurried visit, and they were evidently not ideal; but all circumstances have to be considered—among these circumstances the present difficulty and cost of building—and, having regard to these circumstances, I only wish that we had the Bradford Municipal Hospital at York.

Next we are told by Mr. Hall that there is "no waiting list at the Bradford Royal Infirmary"—with an exception of no importance. I accept Mr. Hall's statement, but I confess to its putting a strain upon me: the difference from most other voluntary hospitals is so great, and I wonder how recent it is that this condition of affairs has been brought about. I have a sort of recollection that the size of its waiting list has at times been urged in the past by the authorities of the Bradford Royal Infirmary as an argument for its extension; but in this my memory may misserve me. Is the explanation that the Municipal Hospital has absorbed the voluntary hospital's waiting list?

Finally, Mr. Hall would complete my discomfiture by a mass of statistics. Statistics are dangerous things to handle, even by a statistician. A judge is reported to have on one occasion talked of "inaccuracies, incredible inaccuracies, and statistics." A variant of the story substitutes for "statistics" "medical evidence." Either would do in this case. Mr. Hall is no statistician. What in the name of all that is wonderful is the good of quoting 1914 figures in this year 1921? A whole epoch has passed since 1914. In 1914 I had a bank account, which was sometimes not overdrawn. I could draw from it nice clean golden sovereigns. With each sovereign I could buy about 100 lb. of sugar, or 60 loaves, or 20 lb. of butter. Five or six would buy me a suit of the finest stuff from Bradford's wonderful mills. Nothing of this remains in 1921. I wish it were 1914 to-day, and so do a good many more, non-socialists as well as socialists.

But the reason why I am supposed to have been "talking

through my hat," whatever that may mean, is that I am supposed to have stated that the "Bradford Royal Infirmary is bankrupt to the tune of £1,000 a month." I made no such statement. What I did state was that the chairman of the Bradford Royal Infirmary was reported to have made this statement. I have a copy of the *Yorkshire Observer* of December 4th by my side as I write. In it Mr. George Priestman is reported to have said, at the opening of a bazaar at the Royal Infirmary, that "to-day the expenditure (of the infirmary) was at least £41,000 . . . and he did not think that in the current year more than £30,000 would be raised" (as income). I believe Mr. Priestman to be the chairman of the Board of the Bradford Royal Infirmary. Is not, then, Mr. Hall's quarrel with the chairman? Ought not he to turn the battery of his statistics on to him; or would it not be better for Mr. Hall to avoid statistics like the plague, and to confine himself to things that are within his capacity? Enough said about Mr. Hall's statistics.

I do not care also for his advice. He quotes with approval as a rule of conduct the adage: "Never believe anything you hear and only half what you see." So far from endeavouring to base my life on this very nasty principle, I always regarded it as evidencing a rather despicable outlook on life which I should endeavour to avoid; but I must say that if I were to read many letters like Mr. Hall's, I would have to confess that it might be wiser for me to reconsider my methods.

So much for six sevenths of Mr. Hall's letter, which concerns myself, and in which he is mostly wrong. I shall endeavour to forget it. It merely serves—or had it been in any way effective, would have served—to darken counsel and to shut out light. But I shall remember the last seventh of his letter, in which he makes a contribution to the problem of voluntarism which may be of value. The proposal he there makes is new to me. It is worth exploring as a means of reconciling the old and dying system of voluntarism with the modern view of civic responsibility. I personally would welcome "co-operation" as heartily as Mr. Hall, although I doubt if the co-operation is to be worth much if it is to be between an inferior, indeed second-rate, municipal hospital and a superior voluntary one, which is to be first class, as Mr. Hall suggests. No municipality could consent to this, nor could the staff of the municipal hospital.—I am, etc.,

York, Jan. 15th.

PETER MACDONALD.

PERSISTENCE OF THE DUCTUS ARTERIOSUS.

SIR,—Dr. Wilson Hall's interesting comments (page 83) on my paper (briefly noticed in your issue of December 25th, 1920) raise two distinct questions:

1. Is the characteristic bruit heard more often in those patients who survive to adult life than in infants? This question was asked in the discussion at the meeting of the Bristol Medico-Chirurgical Society to which my paper was read, but in a rather different form—"How is it that we do not hear this bruit in the newborn infant, considering that the ductus arteriosus normally remains pervious for a few days after birth?" It is interesting to learn from Dr. Wilson Hall's cases that even in those children whose cyanosis is presumably due to an abnormally long persistence of the ductus this murmur was not heard. Possibly the increased force of the adult blood current has something to do with this discrepancy.

2. Is the bruit heard only in those patients to whose congenital anomaly an acquired endocarditis has been added? The case I recorded in which this infection was superimposed on the vascular deformity was one of a young woman whose murmur had existed for at least ten years under my own observation before the symptoms of ulcerative endocarditis arose. Further cases have been recorded (such, for example, as that published by Dr. George A. Gibson in the *Edinburgh Medical Journal*, 1900, new series, vol. viii, p. 1), in which the murmur observed during life has been identified after death with a persistency of the ductus arteriosus to which no endocardial infection has been added. The bruit is, therefore, due to the anomaly itself, and not to any endocarditis that may have supervened.—I am, etc.,

CAREY F. COGNES, M.D., F.R.C.P.Lond.

Clifton, Bristol, Jan. 16th.

THE PREVENTION OF VENEREAL DISEASE.

SIR,—I regret that depreciation of others should form the bulk of Sir Bryan Donkin's letter in your issue of January 15th, for, after all, medical women have, like others, a definite duty to the State in regard to the combating of venereal disease, and, if a determination exists in the minds of many of them to go carefully and with clean hands into this complicated subject, surely the community stands to gain thereby.

The Medical Women's Federation was formed four years ago, with the full knowledge of the British Medical Association, towards which it stands in much the same relationship as does the Society of Medical Officers of Health. Our membership is over 600 and is steadily increasing; it includes all the leading medical women of Great Britain, and these we hope are also members of the British Medical Association. Twice a year a council sits for two days, being attended by representatives from all quarters of Great Britain, and this council acts by appointing representatives on the various committees of the British Medical Association and in other ways, as the official body for obtaining and collating the opinion of medical women—an opinion periodically asked for by Government and by others—and heretofore asked for in vain.

Since women by instinct think in terms of the rising generation, it is inevitable that many medical women who are married, as also their colleagues who are engaged in inspecting children or in conducting pre-natal or venereal clinics, or occupied by hospital or private practice, should desire to bring their scientific and practical experience to bear on the venereal problem. So strongly was this felt at the annual meeting of the Medical Women's Federation in 1918—attended by 100 to 150 members—that it was decided then and there to appoint a committee of those specializing in venereal disease, or specially interested in the subject, with a view to both studying the facts and helping in the national emergency.

Obviously the effective way of helping in this matter, upon which medical men differ so widely, has required much thought. On the one hand stands the Society for the Prevention of Venereal Disease insisting that personal self-disinfection provides the royal road to a marked lessening of venereal disease, whilst on the other side are found men of marked ability and administrative experience—as, for example, Dr. Robertson, M.O.H. Birmingham, who is satisfied that it is impossible to rely on the scientific and successful application of methods of self-disinfection to the civilian community, and is further positive that its propaganda will tend to wreck the home life of our country.

On behalf of the Medical Women's Federation I beg absolutely to deny that there has been "deliberate misrepresentation" of the principles and practice of the Society for the Prevention of Venereal Disease. Herewith are the facts: That society issued a leaflet entitled *Directions to Women*. One of our committee wrote to Dr. Wansley Bayly on the matter, and his reply gave not the slightest indication that the leaflet was meant for prostitutes only. Moreover, the words of their president, to the effect that his society was going "to take every step to ensure that all boys and girls, men and women in the United Kingdom shall have access to the latest scientific knowledge with regard to immediate self-disinfection," lead us to believe that the "directions" were meant to be general. Inasmuch as our short protest has had the desirable result of inducing the Society for the Prevention of Venereal Disease hastily to state that this obnoxious leaflet called "Directions to Women" should in reality be labelled "Directions to Prostitutes," I consider that we deserve the thanks of the public. No man now will be justified in handing one to his wife, as the title suggests; although I gravely fear that what is considered good printed advice for one sort of woman may soon be judged as desirable, even for a loyal wife. Consequently, however many explanations are forthcoming, so long as the leaflets are in existence our desire to criticize them will persist.—I am etc.,

MARY D. STURGE,

President, Medical Women's Federation.

Birmingham, Jan. 18th.

SIR,—A year ago Dr. Otto May and other members of the National Council for Combating Venereal Diseases expressed in letters to the BRITISH MEDICAL JOURNAL concern as to the effects on sexual morality which might

result if people who were liable to incur danger from venereal disease were taught to disinfect themselves quickly. It was feared that such people, hitherto restrained by a sense of communal disapproval, might suppose a communal sanction. Dr. May also expressed doubts as to the efficacy of quick disinfection and desired that the Portsmouth results, and especially those published by me, should be submitted to actuarial examination. He was told how the Portsmouth figures could be easily and exactly tested—and was challenged to test them—and thereupon relapsed into a silence unbroken even by apology. To-day Dr. May, still concerned about morality, is still arguing, on grounds of the prevalence of venereal disease among British troops in Germany, that quick disinfection is ineffectual. Let us, then, get to the facts again. They should greatly interest the mass of the profession—the panel doctors who are collecting materials for the ingenious statisticians of the Ministry of Health.

Before, during, and after the war many medical officers in charge of troops had reduced venereal disease among their men from high figures almost to the vanishing point (see the BRITISH MEDICAL JOURNAL, January 24th, 1920). All these results, which can be fully tested from independent official sources, were achieved not by the issue of packets, but merely by giving men clear and simple instructions as to the mode and danger of infection and the necessity and method of disinfection. Ample disinfectants for supplying men who ask for them have been present since Lister's time in every medical inspection room. In 1918 the War Office resolved to apply the method of quick disinfection to the whole army. An "expert" was placed in charge of the arrangements. Delay occurred, and it was then discovered that millions of "packets" were being manufactured. Unavailing protests that not packets, but clear instructions were required, were made. Delay gave "influential people" their opportunity. The officials, or the expert, proved plastic. When the packets arrived it was intimated that they were for "early treatment." Early treatment is, of course, another name for disinfection, but delayed, not quick disinfection. Presumably it was hoped thereby to delude soldiers into the belief that they were curing not preventing disease. Unavailing protests were again made, and it was predicted that, lacking instructions, the supply of unnecessary packets would not reduce disease. The expected and the predicted happened. Venereal disease was not reduced in the army at large, but in the Portsmouth "area"—all Hampshire and Dorsetshire except Southampton, Netley, and that portion of Hampshire which lies within the Aldershot Command—the practice of teaching quick disinfection spread, and the incidence of venereal disease fell very low, especially in 1919. In that area, however, were many highly infected troops—American, Colonial, and R.A.F., who did not belong to the British Army, and therefore were not instructed. Moreover, into the area came highly infected drafts from other areas, and whole units from overseas. Consequently, the local military authorities, proud of their results, compiled records which carefully distinguished disease acquired by the instructed troops from that acquired by the rest.

In 1919 the Ministry of Health appointed an Inter-departmental Committee ostensibly to inquire into the best methods of reducing the prevalence of disease. Carefully selected evidence from an army which had not used disinfectants as disinfectants was adduced to prove that disinfectants used as disinfectants were useless. The Committee was especially shocked to find that soldiers who had been taught to use disinfectants for early treatment had actually so used them.

The scandal of this committee led immediately to the foundation of the Society for the Prevention of Venereal Disease. The President of the latter, Lord Willoughby de Broke, raised a debate in the House of Lords (December 10th, 1919), and asked for information about the Portsmouth area. Lord Sandhurst, speaking for the Ministry of Health, replied that the incidence of disease in the area (not the town) had before 1919 been twice, and in 1919, two and a half times, as great as in the rest of the kingdom. I had local knowledge, and at once insisted in the press that Lord Sandhurst's figures were monstrously incorrect. Thereupon (February, 1920) the Ministry of Health issued a White Paper in which it was admitted that a great mistake had been made. It seems that Lord Sandhurst's ingenious statistician had taken all the

disease in the area—in the British army and out of it, imported and locally acquired—and attributed it all to the small garrison of the town. Thus had he reached the tremendous figure of 163 for the area. Actually in 1917 the figures for the town were 92 per 1,000 per annum, but in 1919 they had fallen to 54.4 for the town and 47.3 for the area. In 1917 the figures for the whole country were 38; in 1919 they had risen to 64 owing to disease imported from overseas. No attempt is made in the White Paper to explain the fall in the Portsmouth town and area; but it is explained that the rate did not rise in the area (as in the rest of the country) because the area had no port of entry for overseas troops, and so was spared imported diseases. Actually Southampton, the largest port of entry, is a mere enclave in the area, and normally part of it, but separated from it during the war for administrative purposes. Not a man left Southampton by land but passed into the area, and all men for whom accommodation could be found stayed in the area. Its barracks and camps were flooded with overseas troops, and its hospitals swamped with their diseases. By far the greater part of the figures 54.4 and 47.3 was due to imported disease.

Such is the use that the Ministry of Health made of statistics. It has been suggested that it was misinformed. But about what precisely was it misinformed? About the fact that soldiers were told to use disinfectants for early treatment? About the attribution of the disease of the whole area to the small garrison of the town? About the geographical situation of Southampton? About the fact that the hospitals of the area were swamped with imported disease? I am aware that I am making very serious charges. But the Ministry of Health has long been accused of misrepresentation; it has long had all the facts in its possession; if I am anywhere in error, it could long have demonstrated that error very easily; it has not made, and it will not make the attempt. Meanwhile will Dr. May inform us why he supposes that the soldiers in Germany are better instructed than those in the United Kingdom?

The following figures are not mine, but taken from official sources. Before the war 10 per cent. of the inhabitants of the great towns suffered from syphilis. Gonorrhoea is many times more common. Both have greatly increased since the war. Seventy-nine per cent. of the population is urban. On an average from 50 to 100 exposures of men to danger result in one infection. Ordinary women are, of course, less diseased than prostitutes; yet three out of four soldiers acquire their infections from the former. From all this some idea of the extent of immorality and disease in the country may be gathered. Venereal disease is immensely the largest source of waste among us—waste of life, health, happiness, and wealth. Why is immorality so prevalent? Because, notwithstanding all the declamation about morality, no real attempt has ever been made to teach it. If any reader of the BRITISH MEDICAL JOURNAL examines his past, he will find that he learned about sex from boys and that the opinions which he had acquired by the time he reached puberty are, for good or evil, very nearly those which he now holds. As the twig is bent, so the tree grows. Mere preaching to adults, which is all that is practised, is totally ineffective—as again the reader will find if he examines his own consciousness. It is this happy condition of affairs that Dr. May fears will be disturbed by the teaching of quick disinfection. Why is venereal disease increasingly prevalent? For two reasons: On the one hand, much easily preventable disease has been imported from abroad. On the other hand, a campaign of publicity, proclaiming the horrors of disease without any attempt at prevention, has diverted the attention of men, bound under the present system of teaching to be immoral in any case, from the prostitute to the amateur.—I am, etc.,

Southsea, Jan. 17th.

G. ARCHDALL REID.

SIR,—Dr. Otto May's letter appearing in your issue of January 8th, stating "that the broadcast issue of their (the Society for the Prevention of Venereal Disease) instructions implies a sanction to immorality on the part of the community" (his italics), and that "the balance of available evidence is against the efficacy of this form of prophylaxis," is difficult to reconcile with his opinion as

expressed in his introduction to his book *The Prevention of Venereal Diseases*, pages 12 and 13, which reads:

"Medical science can furnish means of aborting or preventing the development of disease in those who run the risk of infection, and in so doing medicine is fulfilling perhaps its greatest function, that of preventing rather than of attempting to cure disease. It is particularly unfortunate [my italics] that many people regard such methods of preventing venereal disease (artificial prophylaxis) as ethically wrong, maintaining that they condone or even encourage immorality."

Perhaps the readers of the BRITISH MEDICAL JOURNAL may consider Dr. May's gymnastics more difficult to reconcile with logical argument than my "heroics." That the Society for the Prevention of Venereal Disease are most anxious that their propaganda should not be taken as "implying a sanction to immorality," but only as a recognition of regrettable but indisputable fact, is shown by the following quotation from the leaflet issued under our authority by the Shipping Federation for the instruction of merchant seamen in immediate self-disinfection: "Distribution of these packets does not imply a sanction to misconduct."—I am, etc.,

London, W., Jan. 13th.

H. WANSEY BAYLY.

SIR,—I am grateful to Lord Willoughby de Broke for his unequivocal statement of the policy of the Society for the Prevention of Venereal Disease, that all boys and girls who have reached the age of puberty "should have access to the latest scientific knowledge of this subject" (venereal prophylaxis).

As a policy it has the merit of being comprehensive, but its consideration opens up curious vistas of the future education of the young. I do not think I can be accused of parody in drawing the following domestic scene in a household "having access to the latest scientific knowledge" as purveyed by the Society for the Prevention of Venereal Disease:

Mary (aged 14, going off for the day to a choir picnic): Good-bye, mother.

Mother: Good-bye, dear. Have you got all you want? You haven't forgotten the permanganate, have you?

Mary: No, mother; it's in my bag all right.

Mother: And, don't forget, if anything should happen, mind you use it at once.

Mary: Never fear, mother; I've got the book of the words, and I don't intend being caught out.

A pleasing peep at the manners and customs of post-war England.—I am, etc.,

London, N.W., Jan. 18th.

OTTO MAY.

RISKS AFTER OPERATION ON TONSILS AND ADENOIDS IN OUTDOOR CLINICS.

SIR.—It will surely be impossible to countenance existing conditions in the face of the numerous letters from influential oto-laryngologists in charge of hospital clinics in Manchester, London, Bristol, Plymouth, York, Portsmouth, Maidstone, while to these I could add equally forcible opinions privately expressed by many colleagues in charge of clinics in many other centres all combine in supporting Mr. Eric Watson-Williams's contention that the risks of complications following these operations are greatly increased when children are sent back straight to their homes instead of being taken into hospital, and of which the figures he cites afford such convincing evidence.

What are the avoidable risks and complications cited by your correspondents? Sir William Milligan says:

"Deaths from the anaesthetic are still too frequent, while complications—for example, acute otitis media, acute mastoiditis, glandular infection, haemorrhage, etc.—are practically unknown if the child is kept in bed and properly nursed for two or three days."

Mr. Herbert Tilley, having experienced the occasional complications Mr. E. Watson-Williams outlined, has adopted the plan of handing printed directions to the parents. Such printed directions are similar to those for a long time used in other clinics and are to be commended; they have an excellent effect in reducing the number of avoidable complications. Better far, however, is the plan followed by the Portsmouth and Southern Counties Hospital, where a certain number of special beds were set apart for these cases in children.

Deaths, acute otitis media (a prolific cause of permanent deafness in after-life), bronchopneumonia, acute sepsis, avoidable, and attributable to operating under conditions

which are preposterous! Are we to continue the infliction of such complications because there is a shortage of adequate accommodation in existing hospitals, and without any appeal to the community at large to alter the conditions? Thousands of beds could be made available to-day in different areas, in Poor Law hospitals, where clinics could be established in charge of specially trained and experienced surgeons. Parents very naturally resent the stigma attaching to Poor Law infirmaries, but, surely, the stigma is a figment wherever enlightened and broad-minded guardians have organized their infirmaries on worthy lines.

Moreover, there are comparatively few working men and women who would not rather have their small children operated on under safe conditions in a Poor Law infirmary if the only alternative was having them sent back to their crowded homes, with far greater risk of dangerous complications, if they only understood what those dangers were; and further, a large proportion of those parents of the hospital class would be willing and able to defray, more or less completely, the cost of operations under such conditions.

If a municipal fever hospital, rate supported, is available for the ratepayer, why should not the same ratepayers find hospital accommodation for these little children in the hospitals under the charge of guardians? The guardians can charge the relatives of these children the cost of their maintenance and treatment, as far as they are in a position to meet those charges.

We have been waiting year after year for "something to turn up," while these children are needlessly subjected to very useful and very necessary operations under conditions which are neither useful nor necessary, if only we were not so hidebound by prejudice and ridiculously out-of-date tradition. And it is difficult to avoid the conclusion that the real and essential obstacle lies not in an *impasse*, but in the medical profession failing to make known far and wide the true facts and issues at stake.—I am, etc.,

P. WATSON-WILLIAMS, M.D. LOND.,

Lecturer on Otology and Laryngology, University of Bristol, and in Joint Charge of the Ear, Nose, and Throat Department, Bristol Royal Infirmary; President, Bath and Bristol Branch of the British Medical Association.

TUBERCULOUS MILK.

SIR,—It was gratifying to read in your issue of January 1st the resolution passed by the Welsh National Memorial Association. I did not think when opening this correspondence that it would produce such rapidly satisfactory results. In this respect a distinctly beneficial function of the BRITISH MEDICAL JOURNAL is demonstrated.

That there is considerable diversity of opinion on the question of the immunization value, if any, of tuberculous milk is evident. One objection, however, to discussing matters such as this in the JOURNAL is that views expressed by medical men, which have potential commercial possibilities, may be made use of by the trade journals concerned. The correspondence has shown that the publications of the dairy trade have made such use of matter from it supporting the present "laissez faire" policy of many dairy farmers, thus helping to defeat the object one had in view in opening this discussion. Fortunately there are many brilliant exceptions to the average dairyman, notably the members of the British Friesian Cattle Society; it is to be hoped that in time the exception will become the rule.

From the scientific point of view your leading article of December 11th, 1920, ably and clearly sums up the present position. It is shown that much patient research is yet required in both the veterinary and medical sides. Your conclusions are that bovine tuberculosis is a menace, and that children should be protected from it; with these the majority of medical men are agreed; that the views of the minority should get so much prominence is unfortunate but human. It is felt, however, that some official pronouncement in plain language, intelligible to medical practitioners and laymen alike, would strengthen the hands of medical officers of health and tuberculosis officers at the present moment.

There is a general impression amongst farmers that the Milk and Dairies (Consolidation) Bill has been, not postponed but scrapped. No doubt the strong opposing interests will see that it is finally disposed of unless those concerned show there is an unquestionably urgent need for

its provisions. In this month's *Public Health* a report of the Council of the Society of Medical Officers of Health states that the matter has been taken up. It is first being dealt with in detail by the Tuberculosis Group, whose considered findings will no doubt be fully endorsed by the society. It is to be hoped that this official statement will receive a wide publicity in the medical, dairy trade, and agricultural journals, and also in the daily press. To those of us who are in daily contact with the milk problem the task seems herculean; nevertheless, there is no valid reason why this country should not become free of tuberculosis in cattle as the island of Guernsey has. The Royal Veterinary College at Camden Town has just inaugurated a campaign with this end in view. Tuberculin for tests and all necessary advice will be given to owners of pedigree cattle.

Finally, Mr. Editor, I wish to thank you for allocating so much of your valuable space to the discussion on this important subject.—I am, etc.,

S. NICOL GALBRAITH,
Medical Officer of Health.

Mid Notts Health Area, Newark-on-Trent,
Jan. 12th.

THE BEGINNINGS OF LIFE.

SIR.—The letter of Surgeon Commander W. Bastian, R.N., inspires me, as a worker on the same subject, to express a word of admiration of the genius of his father, Dr. Charlton Bastian.

Men of genius in research everywhere in science, or in literature, are men of imagination who make brilliant hits, and equally glorious mistakes, so that even as regards the latter one might say, if the Creator did not make it so, well He might have made it so.

Charlton Bastian was such a genius and absolutely devoted to his work, witness how while still possessed of virile strength he entirely gave up an important consulting practice to rusticate himself and pursue that quest of the origin of life that his soul loved. I visited him in his rustic haunts, and was shown his work, and can testify that he knew the part played by light, although I do not think that the products obtained by him were living organisms. But what does this matter to the living thought beneath?—along some such paths life first appeared.

There is no real opposition between Dr. W. Bastian's suggestion and that contained in the leading article of December 25th, as to where life started.

The important point is that the first approach to life must have been self-supporting. There probably were, and may be now, very simple organisms devoid of chlorophyll, or any complicated colour scheme, which could capture sunshine, but such organisms are quite different from those fungi and bacteria which sunshine kills. These latter draw their nutriment from organic matter and cannot live in its absence. Chlorophyll and its compeers are colour screens to protect the delicate photosynthetic mechanism underlying them. They are not the active agents; they are the blinds behind which the active agents work. The serried row upon the seashore of green weeds first, then brown weeds, then red weeds, teaches us this important fact.

In the depths of the Lake of Geneva there is said to be a white or colourless alga. I want to obtain it and see if in dim light it would photosynthesize. Along with my colleagues at Port Erin I have already found that red seaweeds work fastest in dim light; the light of June and July is too great even for the green seaweeds. The same variation in intensity of light which calls forth the vernal outburst in the sea evokes it also upon the land. For many years it had puzzled me in the midst of winter, looking at the dry twigs on the branches, how a new spell of life came to them and the buds swelled out and the fresh green leaves came, just as we all hope to see them soon.

Last spring, in a morning walk over Hampstead Heath, it came to me. Every schoolboy who has ever peeled a wand knows there is a green layer under the outer bark of brown or grey or yellow. The botanist calls it "concealed chlorophyll"; but is it concealed? It delighted me to strip off this layer of outer bark and hold it up to the sunlight and see that the light was breaking through. The violet and blue rays which are inimical to living cells were shut off, but all the others came through. Long

before the buds come and the new green leaves appear photosynthetic processes are already at work under the bark. This I have proven in a score of different trees. What is it, however, that gives the signal to the snowdrop and squill under the brown earth that the god of day is shining a little more every day and that it is now time to awaken? I would I knew. It is no good to call it habit. It must be conditioned by some seasonal stimulus. Does some solar radiation other than visible penetrate beneath the soil and awake the bulbs to their vernal outburst?

The letter of my friend Dr. F. J. Allen also greatly interested me. We have independently been thinking and working upon very similar lines.—I am, etc.,

BENJAMIN MOORE.

Laboratory of Biochemistry, University of Oxford,
January 10th.

SIR,—Your leading article of Christmas week on the beginnings of life once again brings into prominence the question of abiogenesis. Despite its great interest, this question of the time, place, and *modus operandi* of the origin of living matter has hitherto been so deplorably slurred by scientific men—always, of course, with the signal exception of the great neurologist, Charlton Bastian—that it is gratifying to learn that a biochemist of such eminence as Professor Benjamin Moore is now engaged on research work in it. For some years I have been carrying out certain experiments in connexion with the absorbing questions as to how living matter first arose in the past (archebiosis), and as to whether it does or can evolve from non-living matter to-day (abiogenesis). It is difficult to agree with the contention in your last paragraph that the golden key to unlock the long-closed door between non-living and living matter is to be wrested from such relatively highly differentiated forms of life as the algae; moreover, the further inference in the same paragraph that bacteria can only exist on organic matter is surely incorrect. There are many kinds of bacteria capable of living on inorganic materials. I have kept such prototrophic micro-organisms for several months, and seen them flourish and multiply in water containing no other food supply than dissolved gases and inorganic salts.

The experiments alluded to above were conducted on the general lines indicated by Charlton Bastian, who, shortly before his death, was good enough to furnish me with certain suggestions relating to them. They differ, however, from those of Dr. Charlton Bastian in that inorganic solutions only were used. For sterilization of the hermetically-sealed tubes reliance was placed on the high temperature of steam under pressure in an autoclave, after which, at and for varying intervals of time, the sterilized contents were exposed to the energizing influence of heat, light, and electricity. It must be confessed that, up to the present, these experiments have yielded negative evidence of the development of living matter. The tubes when opened—even after the lapse of years—showed sterile contents, yet some twenty-four hours after opening, the inorganic medium was swarming with living organisms. There is, however, always the hope that success will attend future experiments when science has succeeded in bringing the microcosmos—as represented by the sealed tube with its miniature ocean of water and salts and its miniature atmosphere of gases—into better approximation to those conditions which existed in the macrocosmos as represented by the primaeval world when living matter first appeared on its stage.—I am, etc.,

Royal Naval Hospital, Chatham,
Jan. 9th.

C. MARSH BEADNELL,
Surgeon Captain R.N.

GLANDULAR FEVER.

SIR,—I read with much interest Dr. Tidy's letter on glandular fever (p. 100). There is no doubt that the disease is quite common and more attention should be paid to it. I described an epidemic occurring in my own practice in the BRITISH MEDICAL JOURNAL of January 24th, 1914. Since then I have had several outbreaks presenting the same features. The real interest of the disease lies in the nature of the infection. Surely this could be settled by the excision or puncture of one of the glands. It has been suggested that it is an attenuated bubonic plague, which does not seem very probable.—I am, etc.,

Wanstead Park, Jan. 16th.

A. CAMPBELL STARK.

TREATMENT OF THE PRE-OPERATIVE STAGE OF ENLARGED PROSTATE.

SIR,—The valuable remarks of the distinguished urologist on this subject in the JOURNAL of January 15th call for some criticism in a few directions. With your permission I shall take up three. First, it is quite apparent that operation is urged in all cases allowing of it; second, that the disease is progressive; and third, that a certain symptom—frequency of micturition—is pathological (necessarily so).

Taking the last first, in my experience there is scarcely a man or woman over 50 who does not urinate once or oftener at night. So common is it in the absence of gross lesion that I attribute it to waning tone in the sphincter vesicae.

Then as to the second and first points: prostatic hypertrophy is not usually a progressive disease after a certain stage is reached, despite the view to the contrary. I have patients under my care whom I first attended for this state twenty years ago, and they are not worse now than at the beginning or when I first saw them. Is every poor old fellow with enlarged prostate—a condition so common as almost to be thought natural, and there are no prostates quite normal after 55—to be urged to operation? Is there no better way for some?

In my opinion no man should have his prostate removed unless his symptoms are progressing, or are spoiling his health, or unless the salient state is obstruction. True, if he likes to be in fashion, and deems himself pretty sure of the company of some 94 or 95 who recover, let him take the small risk; but to be amongst the other party of five or six is a poor exchange for a malady which never may seriously trouble him.

Congestion and oedema of mucous membrane cause most immediate trouble. No one who has not conscientiously tried palliative treatment should disregard it. Many of my patients are using with the greatest benefit hot and cold douching combined with massage by a special instrument I got constructed. It consists of a large perforated bulb. It is as necessary to massage the prostate from apex back as it is from base forward. One pressure forces secretions out, the other aids the veins. With many more I use sounds and instillations. Amongst drugs, ergot, salix nigra and their class often do much good. To do these things gives some trouble, but scarcely more than a shave. "Adenomatous" prostate is, I fear, a misused term in many cases.

As to treatment, the chief point is to distinguish irritation from obstruction.—I am, etc.,

London, W., Jan. 16th.

JAMES MACMUNN.

X-RAY RADIATION IN CANCER.

SIR,—Mr. Sampson Handley, in his Association lecture on the lines of advance in the surgery of breast cancer, reported in the JOURNAL of January 8th, urges the use of x rays, perhaps before, and certainly after, operations for breast cancer. He indicates that their value depends on the doses in which they are given, and suggests that harm may be done both by under- and over-dosage—in the first case by stimulating the growth of cancer cells, and in the second by breaking down the patient's (or experimental animal's) resistance.

Since 1905 I have been asking a colleague who undertakes x-ray treatment what dosage he employs in these cases, and I find that not only cannot he himself tell me, but that x-ray specialists to whom he has repeatedly referred the question at various times have not apparently framed a scheme of treatment by accurately measured doses, and seem to work more or less by rule of thumb.

It would add to the confidence of those who advise x-ray treatment if Mr. Handley would state in quantitative terms what he considers to be the optimum doses for the cases under discussion.—I am, etc.,

Colwyn Bay, Jan. 11th.

ROBERT E. LORD.

SIR,—Mr. Sampson Handley's lecture which you published in the JOURNAL for January 8th is of profound importance, not only from a surgical but also from the radiation point of view. It is the latter that especially interests me.

It is really refreshing to note the emphasis which a surgeon of Mr. Handley's pre-eminence in the special

department of surgery on which he is writing lays on radiation. This method of improving the chances of patients operated on for breast cancer is not nearly so commonly carried out as it ought to be. Its neglect is, of course, due to the surgeon's lack of recommending it in connexion with his surgical procedure.

I have carefully observed for many years the results of surgery in breast cancer without radiation, and with ante- or post-radiation, or both. There is no doubt in my mind that both ante- and post-radiation are very desirable, and enormously improve the patient's chance of increased length of life. I think that x-ray radiation is generally the most applicable. This must be done through aluminium filters, and ought to be applied in "massed" doses.

Mr. Handley says that "the practice of giving large doses of x rays prior to operation is probably a sound one, though its value is not easily susceptible of proof." This is true. Might I suggest that the action is of several kinds? The cancer cells in the lymphatics are probably "fixed" by the radiation; some of the isolated cells in these regions are sterilized; and at the same time an immunizing agent is produced in the tissues which lessens the power of small colonies of cells to further proliferate. The latter is probably a form of ionization produced in the tissues by the action of the x-ray radiation.—I am, etc.,

London, W., Jan. 17th.

JAMES METCALFE.

THE TEACHING OF ANATOMY AND PHYSIOLOGY.

SIR.—The criticisms of Professor Berry, in his paper on the teaching and study of human anatomy in your issue of January 15th, call attention once more to the defects in an important part of the medical curriculum. There is room for improvement in the correlation of the different branches of medical science throughout the curriculum, but at no time, in my opinion, is this more patent than in the early years.

Anatomy and physiology are too often taught as subjects unassociated with the later clinical work; this detachment is further emphasized by the medical school and hospital being separate buildings, often at a considerable distance from one another; and by what is of more significance to the student, the all-important intervening event of an examination. The successful candidate breathes a sigh of relief, as much as to say at last he is coming to the real part of his education. This appearance of an abrupt cleavage in a student's career is obviously wrong. There is another ill effect, too, I think, in this disjointed method of teaching, and that is (especially as regards anatomy) it becomes largely a matter of stuffing the memory at a stage in a student's life when every effort should be made to educate observation, reasoning, and breadth of view. And, as Professor Berry points out, the memory is crammed with much that is of little practical use subsequently, and, as he might have added, the knowledge so acquired is in many respects fallacious, for it gives rise to an impression of inflexibility and rigidity of tissues (inseparable from the method of preservation of the bodies) and inferentially of their functions, which is quite at variance with what is afterwards found to be the case when dealing with living material.

Sir Berkeley Moynihan, a few years ago, presented medicine with one of the really great gifts of modern times—namely, the conception of the pathology of the living. The extension of this idea to teaching throughout the medical curriculum goes to the very heart of the matter; and so far as anatomy and physiology are concerned the obvious remedy is to set students to hospital work at the time they now begin anatomy and physiology, so that these subjects might be taught concurrently with clinical work. I doubt whether teachers of the present generation would be capable of giving quite the right kind of instruction, except perhaps by team work. But in the future, and little by little, knowledge would develop on the lines on which the preceding generation had been taught; teachers would then be able to expound the principles of anatomy and physiology in their clinical bearing in a way that is at present scarcely possible.

This principle of overlapping and correlating could be very well extended to all other aspects of medical education, and if it should be argued that the available time would forbid, I think there are some subjects included in the present curriculum which might very well be curtailed or deleted as special subjects—to mention two,

materia medica and therapeutics; all that it is necessary to know of these could be satisfactorily incorporated with physiology and bacteriology—to the benefit, I venture to think, and undoubtedly to the unspeakable delight of the student with his over-taxed memory.

Another way of utilizing time more profitably would be to dispense with all systematic lectures; these have a soporific rather than a stimulating effect on most students, and the knowledge which it is intended to convey in this manner could be more usefully and interestingly imparted either at clinical lectures or at the bedside.—I am, etc.,

E. R. FLINT,

Leeds, Jan. 16th.

Surgical Lecturer, General Infirmary, Leeds.

FATAL POISONING FROM INHALATION OF ACID FUMES.

SIR.—The cause of the fatal poisoning by acid fumes, which Dr. T. G. Moorhead reports in the *BRITISH MEDICAL JOURNAL* of January 15th, is somewhat obscure, and as he no doubt wishes to invite some observation which may tend to clear up the unexpected fatality, I venture to offer the following remarks:

Among the exercises that Dr. Moorhead mentions was the identification of Sb₂S (stibnite). Under ordinary circumstances the action of pure H₂SO₄ on stibnite would not produce a poisonous gaseous product, but if a metal happened to be present nascent hydrogen would be developed, which would act upon the Sb of the stibnite, producing stibine (SbH₃), a gaseous and highly poisonous product. I hope this may lead to an elucidation of this fatality.

Another explanation may be afforded by the quality of the H₂SO₄ used; if it contained As₂O₃ as one impurity, an analogous reaction would take place in the presence of a metal, in this case arsine (AsH₃) being formed.—I am, etc.,

NINIAN M. FALKNER, M.D.,

Vice-President, Royal College of Physicians of Ireland.

Dublin, Jan. 17th.

THE STUDY OF HEART DISEASE.

SIR.—Last November, at a meeting of the Medical Society of London, it was agreed that heart disease is more prevalent among the children of the poor than among those of the well-to-do, but no answer was forthcoming to the question why?

The admission implies that a difference of conditions is responsible for this greater incidence, and if we could but settle the point wherein that difference lies we would achieve something of very great national importance.

We have to admit that Jewish children living in the slums have as good a health rate as that of wealthier children, from which we must infer that poverty, as such, is not a cause, for the houses in which the former live are not good, their clothes are secondhand, and dirt abounds, but their Kosher food is first-class. Can we establish the fact that in the poorness of the food lies the cause of the greater tendency to rheumatic fever and chorea amongst the Christian poor?

The question on which I lay great stress is whether children get sufficient lime-bearing foods, such as milk, eggs, or cheese, in the ash of which calcium forms a high percentage. Some children cannot get them, others cannot take them, preferring salty and acid foods, and I cannot but think that until they all can and do take them so long will this great tendency to rheumatic fever and chorea exist.

Our milk supply requires overhauling, and we need to encourage fowl-rearing if progress is to be reported, but increased production of all sorts is the secret of national success.—I am, etc.,

Swansea, Jan. 16th.

G. ARBOUR STEPHENS.

THE NAVAL MEDICAL SERVICE.

SIR.—The letter by "Action" on this subject in your issue of January 8th is very much to the point. Letters lead nowhere unless followed by action. I fear, therefore, unless the Naval Medical Service can enlist sympathy and help from outside it is up against a blank wall. To my mind there are two fundamental reforms essential before any real improvement is possible. The first is that the Medical Department of the Admiralty must have entire charge of its own affairs; for instance, until medical promotions and appointments are entirely in the hands of

medical men, progress is extremely difficult for obvious reasons which I will not press. Secondly, medicine must be represented on the Board of Admiralty. Surely, after the experience of the past few years, all combatant officers realize what an enormous factor in winning a war efficient medical and sanitary organization has become and how the importance of this factor will tend to increase as medical science advances. This being so, how can any board consider itself fully competent to control a fighting service without medical representation?

Should the above reforms ever materialize, it follows that other grievances, professional and financial, will become much easier to rectify. Discontent is a drag on the efficiency of any body of men, and everything in reason should be done to remove it. It is no exaggeration to say that the Royal Naval Medical Service is at the present time seething with discontent; a fact which saddens anyone who has the welfare of the Senior Service at heart.—I am, etc.,

January 9th.

"ANXIOUS."

The Services.

THE ARMY OF THE BLACK SEA.

IN the dispatch, just published in the *London Gazette*, from General Sir G. F. Milne, Commander-in-Chief of the Army of the Black Sea, it is stated that the health of the troops has been good, the greatest zeal, foresight, and skill having been displayed by the R.A.M.C., under the Director of Medical Services, Major-General Sir M. P. C. Holt, K.C.B., K.C.M.G. By July, 1919, most of the men suffering from malarial relapses had been sent home, and there had been practically no primary malaria since the army left Macedonia. Besides purely military duties, it had been necessary for the medical services to undertake, in conjunction with our allies, the sanitary supervision of the port and town of Constantinople—a task of peculiar difficulty owing to the constant transit of refugees and the many epidemics prevalent in that part of the world. The Inter-Allied Sanitary Commission, which supervised this work, was presided over first by Colonel W. H. Nickerson, V.C., C.B., C.M.G., and later by Major-General Holt, D.M.S. The health of the population and the absence of epidemic disease were the best testimony to the work of this Commission. They gave devoted services also to the sick refugees and wounded from South Russia, numbering some 10,000. General Milne records, likewise, his appreciation of the excellent work performed by Queen Alexandra's Imperial Nursing Service, and by the ladies of the Voluntary Aid Detachments.

The names of the following additional medical officers are mentioned for distinguished and gallant services:

Captain and Brevet Major (acting Lieut.-Colonel) R. E. Barnsley, M.C., and Captain W. Bird, of the 84th Field Ambulance, R.A.M.C.; and temporary Captain H. C. Mitter, 84th Field Ambulance, I.M.S.

MINISTRY OF PENSIONS: THE "OFFICERS' FRIEND."

WE are asked to announce that disabled officers and nurses who served during the great war, and widows and dependants of officers deceased can obtain helpful advice and information regarding their rights under the regulations of the Ministry of Pensions, by applying to the "Officers' Friend," Ministry of Pensions, Cromwell House, London, S.W.1, or the "Officers' Friend," at any of the Regional Offices of the Ministry, Burton Court, Chelsea, S.W.1; Newcastle-on-Tyne; Manchester; Bristol; Leeds; Nottingham; Birmingham; Edinburgh; Dublin; Belfast; or Cardiff.

HONOURS.

ORDER OF THE BRITISH EMPIRE.

THE following appointments to the Order of the British Empire are announced for services in connexion with the war:

O.B.E. (Civil Division).—Dr. M. A. Johnston de Lavis Trafford, senior medical officer, Red Cross Hospital, Turin.

M.B.E. (Civil Division).—Dr. W. L. Clubb, medical officer, Minley and Farnborough Court Auxiliary Hospitals, Farnborough; Dr. Edmund Lloyd, a Church Missionary Society doctor in charge of relief and hospital work at Gaza.

DEATHS IN THE SERVICES.

LIEUT.-COL. STANDISH DE COURCY O'GRADY, C.M.G., D.S.O., R.A.M.C., died at the Military Hospital, Malta, on December 23rd, aged 47. He was born at Dresden on July 27th, 1872, and educated at Trinity College, Dublin, where he graduated M.B., B.Ch., and B.A.O. in 1896. Entering the army as surgeon lieutenant on July 27th, 1898, he became captain in 1901 and lieutenant-colonel on March 1st, 1915, and was appointed temporary colonel on October 30th, 1916. He had also qualified as a specialist in State medicine at the R.A.M.C. College. He served in East Africa in the Somaliland campaign of 1904, was mentioned in dispatches in the *London Gazette* of September 2nd, 1904, and received the medal with a clasp. In the recent

war he was thrice mentioned in dispatches: in the *Gazette* of February 17th, 1915, May 29th, 1917, and December 30th, 1918; received the 1914 star, with the war medal and the Victory medal, the D.S.O. on June 3rd, 1917, and the C.M.G. on January 1st, 1919.

Obituary.

JOHN WILLIAM SIMPSON, M.D., F.R.C.P. EDIN.,
Physician, Royal Edinburgh Hospital for Sick Children.

ON January 11th the news of the death of Dr. J. W. Simpson came as a sudden shock to medical circles in Edinburgh. Dr. Simpson, it was known amongst his friends, had undergone a serious operation some months ago, but he had made a good recovery, and hardly any one knew that he had been attacked with pneumonia until that disease proved fatal in some four days. His death falls heavily upon the Royal Edinburgh Hospital for Sick Children, of which he was one of the physicians; for within a very few years this institution has lost by retirement, by death, and by removal from Edinburgh no fewer than five of its senior medical and surgical staff.

Dr. Simpson was educated at Dollar and later at the Edinburgh Royal High School. He then passed to the University of Edinburgh, where he graduated as M.B. and C.M. in 1896, and as M.D. in 1906. He became a Member of the Royal College of Physicians of Edinburgh in 1899 and was elected a Fellow in 1903. He held several medical posts in Edinburgh in the years following upon his graduation, such as house-surgeon, house-physician, and house-surgeon to the eye wards in the Royal Infirmary, and physician to the Cowgate Dispensary. Then he was appointed registrar and resident medical officer to the Hospital for Sick Children, and finally became one of the physicians to that institution. During the years in which Dr. Simpson was holding these appointments he was also building up an excellent consulting practice in the diseases of children, and was making several additions of value to the literature of that subject, of which the most outstanding was his *Guide to the Feeding of the Infant during the First Year*. He also contributed articles on infantile maladies to the *Edinburgh Medical Journal*, to the *Scottish Medical and Surgical Journal*, and to the *BRITISH MEDICAL JOURNAL*, and in every case his contribution contained facts worthy of record.

To many in a wider circle Dr. Simpson was known and admired as a Rugby football player of the first rank; he shone in the nineties of the last century in many a stubborn contest, both for his old school (the Royal High School) and for his country in international games, in thirteen of which he played against England, Ireland, and Wales. He continued in touch with the game after ceasing to play by acting first as a member and later as the president of the Scottish Rugby Union Committee. He added fishing and golf to the outdoor sports of which he was fond; and in his passing to and fro in the streets of Edinburgh one could not fail to note the swing and the lithe strength of the athlete. To many patients and to a large circle of friends Dr. Simpson's death will be a real bereavement. The funeral, at the Dean Cemetery, took place on January 14th.

Universities and Colleges.

UNIVERSITY OF OXFORD.

Radcliffe Travelling Fellowship, 1921.

AN examination for a Fellowship of the annual value of £200, and tenable for three years, will be held during the present term, commencing on Tuesday, February 22nd, at 10 a.m. Candidates must not have exceeded four years from the time of passing the Final B.M. examination. The successful candidate must before election declare that he intends to devote himself during the period of his tenure of the Fellowship to the study of medical science, and to travel abroad with a view to that study. The examination will occupy four days. Papers will be set in physiology, pathology, and preventive medicine, and a subject will be proposed for an essay; there will also be a practical examination in pathology. Any candidate desiring to offer in addition a special branch of either medicine or surgery must send notice of this to the Regius Professor of Medicine on or before February 2nd. All intending candidates should send their names, addresses, qualifications, etc., to the Regius Professor of Medicine, University Museum, on or before Wednesday, February 2nd.

ROYAL COLLEGE OF SURGEONS OF ENGLAND.

A QUARTERLY COUNCIL was held on January 13th, when Sir Anthony Bowlby, President, was in the chair.

The President reported that the Prince of Wales would honour the College with his presence at the Hunterian Festival Dinner on February 14th, and receive the diploma of Honorary Fellowship, to which His Royal Highness was elected on July 24th, 1919.

The Diploma in Public Health was issued to thirty candidates found qualified by the Conjoint Colleges. In Tropical Medicine and Hygiene diplomas were granted to twenty-five candidates. In Psychological Medicine diplomas were issued to four candidates.

An alteration in the fees for the several examinations for the Licence in Dental Surgery was necessitated by changes in the regulations which have now come into force. Under these the examinations in general and dental anatomy and physiology are separated from the examinations in general dental surgery and pathology and form part of the first professional examination; and candidates who have passed the Preliminary Science Examination can present themselves for examination in general and dental anatomy and physiology after completing six months' study during the ordinary sessions at a recognized medical and dental school.

The Onodi Collection.—The Council accepted this collection (of nasal anatomy) as a gift from the Onodi Committee, and undertook the preparing and mounting of the specimens for display. The thanks of the Council for the donation was accorded to the donors.

The French Academy of Medicine.—A letter was read from Sir D'Arcy Power reporting the attendance of the College delegates at the centenary celebrations of the French Academy of Medicine in Paris on December 20th-23rd, and a letter from the secretary of the French Academy acknowledging the receipt of the address of congratulation presented by the delegates on behalf of the College.

Medical News.

A DINNER to Major-General Sir Robert Jones, K.B.E., C.B., will be held on January 31st, at 7 p.m., at the Midland Adelphi Hotel, Liverpool, on the occasion of the presentation of his portrait by his old colleagues and friends at the Royal Southern Hospital, Liverpool. The Earl of Derby will preside. Tickets, £1 ls. each, can be obtained from Mr. T. R. W. Armour, 42, Rodney Street, Liverpool.

THE Liverpool and District Overseas Medical Officers will hold their third annual dinner at the Midland Adelphi Hotel, Liverpool, on Friday, February 11th, 1921, when the Director-General, Army Medical Service, Lieut.-General Sir John Goodwin, K.C.B., C.M.G., D.S.O., hopes to be present. Tickets may be obtained from the honorary secretary, Captain G. F. R. Smith, 19, Queen's Drive, Mossley Hill, Liverpool.

THE annual dinner of the Hunterian Society will be held on Wednesday, February 2nd, at the Trocadero Restaurant, at 7 p.m. for 7.30, with Dr. A. C. Jordan, President, in the chair. Ladies will be invited. The price of the dinner is 16s. 6d., exclusive of wine.

WE are asked to state that the Council of the National Medical Union has made a protest against the regulations with regard to the new insurance record cards, which they consider involve a breach of confidence between the patient and medical adviser.

A PAPER on "Medicine in India" will be read by Dr. Cecil Webb-Johnson before the East India Association on Monday, January 24th, at 3.30 p.m., at 3, Victoria Street, Westminster, S.W. Sir Ronald Ross will preside.

FOUR lectures on communicable diseases will be delivered by Sir Robert Armstrong-Jones at Gresham College, Basinghall Street, E.C. on January 25th, 26th, 27th, and 28th, at 6 p.m. Admission is free.

THE following course of Emeritus Lectures and Addresses has been arranged for the ensuing session at the Middlesex Hospital Medical School. Surgeon Rear Admiral Bassett-Smith will lecture on February 1st, 3rd, and 8th on Mediterranean fever, malaria, and trypanosomiasis respectively. Sir Alfred Pearce Gould will lecture on February 22nd on "Surgery—a progressive science, the latest word is not the last word." Sir R. Douglas Powell will lecture on February 25th and March 14th on "The etiology of phthisis." On March 1st, 3rd, and 8th Dr. W. McC. Wanklyn will lecture on "The future of the medical profession." On March 11th and 18th Sir James Kingston Fowler will lecture on "The treatment of tuberculosis," and on June 3rd Dr. C. Hubert Bond will lecture on psychiatry. Visitors are cordially invited to the lectures, which will be held in every case at 3 p.m.

A SESSIONAL meeting of the Royal Sanitary Institute will be held, jointly with the West of England Branch of the Society of Medical Officers of Health, on Friday, January 28th, in the Guildhall, Exeter, at 4.30 p.m., when a discussion on "The Sanatorium Question" will be opened by Dr. E. Ward, Tuberculosis Officer, Devon County Council.

THE annual general meeting and conversazione of the Harveian Society of London was held on January 13th. Dr. Turtle was elected president for the ensuing year. The retiring president (Dr. Hill) delivered an address on the great advances in the methods of treatment of disease of the oesophagus during the present century. The adjourned debate on the future of the Poor Law infirmary will be held at the Paddington Town Hall on Thursday, January 27th, at 8.30 p.m., when Dr. Stewart of the Paddington Infirmary and Dr. Duffield, M.O.H. Paddington, will speak.

A SERIES of post-graduate courses is being arranged at the Manchester Royal Eye Hospital to commence early in February. There will be three courses, each consisting of twelve demonstrations; they will deal with (1) external diseases of the eye, (2) diseases of the fundus oculi, and (3) refraction. The fees are £3 3s. for each course, and those proposing to join should communicate with the honorary secretary, 28, St. John Street, Manchester.

CLINICAL instruction in the treatment of venereal diseases will be given to general practitioners by Colonel L. W. Harrison in the Male Department (Hut E) of St. Thomas's Hospital, each Friday at 5.30 p.m. Admission on presentation of card.

Letters, Notes, and Answers.

As, owing to printing difficulties, the JOURNAL must be sent to press earlier than hitherto, it is essential that communications intended for the current issue should be received by the first post on Tuesday, and lengthy documents on Monday.

ORIGINAL ARTICLES and LETTERS forwarded for publication are understood to be offered to the BRITISH MEDICAL JOURNAL alone unless the contrary be stated.

CORRESPONDENTS who wish notice to be taken of their communications should authenticate them with their names—of course not necessarily for publication.

AUTHORS desiring reprints of their articles published in the BRITISH MEDICAL JOURNAL are requested to communicate with the Office, 429, Strand, W.C.2, on receipt of proof.

In order to avoid delay, it is particularly requested that ALL letters on the editorial business of the JOURNAL be addressed to the Editor at the Office of the JOURNAL.

THE postal address of the BRITISH MEDICAL ASSOCIATION and BRITISH MEDICAL JOURNAL is 429, Strand, London, W.C.2. The telegraphic addresses are:

1. EDITOR of the BRITISH MEDICAL JOURNAL, *Aitiology, Westrand, London*; telephone, 2630, Gerrard.
2. FINANCIAL SECRETARY AND BUSINESS MANAGER (Advertisements, etc.), *Articulate, Westrand, London*; telephone, 2630, Gerrard.
3. MEDICAL SECRETARY, *Medisecra, Westrand, London*; telephone, 2630, Gerrard. The address of the Irish Office of the British Medical Association is 10, South Frederick Street, Dublin (telegrams: *Facilius, Dublin*); telephone, 4737, Dublin, and of the Scottish Office, 6, Rutland Square, Edinburgh (telegrams: *Associate, Edinburgh*); telephone, 4361, Central.

QUERIES AND ANSWERS.

INCOME TAX.

"R. M." has received some inquiries from the local inspector of taxes which are open to the construction that they are intended to elicit information as to the liability of the practitioner for whom our correspondent was acting during the war.

We suggest that "R. M." might inform the inspector that as the information could doubtless be supplied with equal facility by the other practitioner he feels he must demur to giving the information unless the income tax authorities require him to do so, in which case the inspector can perhaps supply a reference to the statutory authority. We have not previously had our attention called to an official request for particulars of payments made by one practitioner to another and very much doubt if the request has legal justification.

"J. H. T." originally possessed two motor cars for his practice; one was sold for £100 during his service in France, and has now been replaced by a car of another make costing £1,100.

Our correspondent can treat as a professional expense that portion of the £1,100 which represents the net cost of replacing (apart from any improvement) the old car. For instance, assuming that that car originally cost £450, and at the

date the new car was purchased for £1,100 would have cost £950, then of the £1,100 - £400 = £700, the net cost of the exchange of cars, £150 represents improvement and £450 replacement; this £450 is, of course, £950 (the supposed cost of the exact replacement) less the £400 received for the old car.

"M.D.CANTAB." has received the application for income tax and inquires why his earned income should be charged at 6s. in the £.

* * The rates of tax for earned and unearned income are now identical, the only difference in their assessment being the deduction of 10 per cent. (maximum deduction £200) in assessing the earned income. We therefore cannot say whether the 6s. charge is correct without further particulars of the assessment. These should have been shown on the earlier and more detailed "notice of assessment."

"ALPHA" asks for rather more information than can be adequately conveyed in a short note. The following, however, may assist him:

* * Tax is payable under Schedule A on the rental value of the house, and at the 6s. rate so far as that represents income passed on to the mortgagee, etc., under deduction of tax. One-half the rent and rates is presumably reasonable, but if only one maid is kept probably one-third of her wages and board would be enough. The child cannot be claimed for this year. The purchase of books, periodicals, etc., is allowable so far as incurred to maintain—not to create or improve—the practitioner's library.

"F. J." asks what allowances are due for supertax.

* * None; the "income tax" allowances do not apply to supertax, which is chargeable on the excess of the total income over £2,000.

"MEDICUS."—The calculation appears to be correct, except that as regards income from investments there is no allowance due for earned income. Consequently the amount repayable would be less than that suggested by £90 @ 6s. = £27.

LETTERS, NOTES, ETC.

THE HALF-YEARLY INDEXES.

THE usual half-yearly indexes to the JOURNAL, SUPPLEMENT, and EPITOME have been prepared and will be published shortly; they will, however, not be issued with all copies of the JOURNAL. Any member or subscriber wishing to have any or all of the indexes should communicate with the Financial Secretary and Business Manager, 429, Strand, W.C.2. Those wishing to receive the indexes regularly as published should also intimate their desire.

APPENDIX COMMUNICATING WITH COLON.

DR. CHARLES E. ETHERIDGE (Whitstable), in sending the following note, states that he can find no record of a similar condition. When making a *post-mortem* examination on an old woman of 65, who was found dead kneeling before her copper fire, the following condition of the appendix was found: The proximal end originated in the usual position on the caecum, but there was no free end, as the appendix curved upwards and joined the ascending colon on its inner side about an inch above the caecum. There was no thickening and no evidence whatever of any old inflammation, ulceration, or adhesions. The total length of the appendix was about 5½ in., and I was easily able to pass a pair of dressing forceps right through from caecum to colon, and from examination of the contents of the appendix there was evidently a free passage of liquid intestinal matter through this by-way.

"ONE WAY OF SELECTING A HEALTH RESORT."

DR. ANDREW ROSE (Bath) writes: With reference to the note under this heading in your issue of January 8th, I do not think Dr. Johnson Smyth's patient could have visited any of the graveyards in Bath before deciding permanently to reside in Bournemouth. He would, I venture to predict, find the tombstones to record an even higher percentage of persons dying at 81 and over than even in salubrious Bournemouth. Here it is not a very uncommon occurrence to find people living to well over the century. Indeed, only the other day a lady of 101 sent an autograph letter of birthday greetings to another Bath resident of 102. And even if Dr. Smyth's patient had taken a stroll through the city he would be surprised at the alertness and vivacity displayed by the ladies and gentlemen of from 70 to 80 and over, whom he would constantly come across, and who each day seem to get younger instead of older. Truly, Bath has a charm for old age.

TINNITUS AURIS.

"J. J. A. N." (Natal) writes in reply to a request by "W. A. B." for information regarding tinnitus aurium in the JOURNAL of November 6th, 1920; I have found thyroid extract in gr. 2½

doses night and morning to give the most satisfactory results in old patients. If and when improvement takes place, the dose should be lessened to one tablet at night, and the dose still further lessened as indicated by the progress of the case. Examination of the fundus should give some suggestions in "W. A. B.'s" case; this occurs to me because he mentions that the tinnitus is aggravated by lying down. Evidently there is a disturbance in pressure balance, vascular alone perhaps. I presume that the teeth are in order, and that the question of tobacco has been looked into. I might add that one is always glad to learn the results of carrying out suggestions.

TENNIS ELBOW.

IN the short correspondence in this column last year on the subject of tennis elbow reference was made to an article by Dr. Wm. Pearce Coues, but the writer of the note was unable to give the reference. We now have to acknowledge the receipt from Dr. Coues of a reprint of his article, which appeared in the *Boston Medical and Surgical Journal*, vol. clxx No. 13, pp. 461-465, March 26th, 1914. Dr. Coues admits that while the treatment of this condition is most unsatisfactory, most authors agree that heat and fixation seem to be the best methods, with massage as a supplementary measure; six months of disability or, at least, of foregoing the chosen exercise must be looked for. He suggests that there might be two lesions causing the symptom-complex known as tennis elbow: first, a partial tearing of some of the muscular attachments from the external epicondyle, giving rise to the separation of bony spicules, with the possibility of a periostitis from such tearing; second, injury to the radio-humeral joint capsule from antagonistic muscular contraction of the supinator brevis and supinator longus. Lastly, Dr. Coues does not think that the theory of predisposition to arthritis deformans of the radial head can be accepted in all cases.

GRADUATED BOTTLES.

"SENEX" writes: It has often occurred to me that if panel chemists, either voluntarily or compulsorily, were to dispense all medicines for internal use in graduated bottles much trouble would be avoided. In common, I believe, with many of my confrères whose lines are cast in industrial areas, a large number of my panel patients swallow their medicine without regard to the dosage ordered. It is common knowledge that the working man's teaspoon holds much more than half an ounce (often double that quantity), and so he returns, Oliver-like, asking for more long before he is entitled to it. I am convinced that the charge of prescribing with undue frequency, resulting in a surcharge for "over-prescribing," would be made in fewer cases if graduated bottles were used.

VACANCIES.

NOTIFICATIONS of offices vacant in universities, medical colleges, and of vacant resident and other appointments at hospitals, will be found at pages 33, 35, 36, 37, 38, and 39 of our advertisement columns, and advertisements as to partnerships, assistantships, and locum tenencies at pages 34 and 35.

THE following appointments of certifying factory surgeons are vacant: Chipping Campden (Gloucester), Kilbride (Dute), Moville (Donegal), Tattenhall (Chester), Wansford (Huntingdon and Northampton), Warminster (Wilts).

THE post of medical referee under the Workmen's Compensation Act, 1906, for the Sheriffdom of Stirling, Dumbarton and Clackmannan, is vacant. Applications to the Private Secretary, Scottish Office, by February 5th.

The *Record of the Save the Children Fund* is published twice monthly, at a price of threepence, and contains an account of its activities for the relief of child distress and for assisting child-welfare efforts in nearly a score of different countries, from Britain and France to Hungary and China.

SCALE OF CHARGES FOR ADVERTISEMENTS IN THE BRITISH MEDICAL JOURNAL.

	£	s.	d.
Six lines and under	0	9	0
Each additional line	0	1	6
Whole single column (three columns to page)	7	10	0
Half single column	3	15	0
Half page	10	0	0
Whole page	20	0	0

An average line contains six words.

All remittances by Post Office Orders must be made payable to the British Medical Association at the General Post Office, London. No responsibility will be accepted for any such remittance not so safeguarded.

Advertisements should be delivered, addressed to the Manager, 429, Strand, London, not later than the first post on Tuesday morning preceding publication, and, if not paid for at the time, should be accompanied by a reference.

NOTE.—It is against the rules of the Post Office to receive *post-restante* letters addressed either in initials or numbers.

THE THEORY OF DISTURBED REFLEXES IN THE PRODUCTION OF SYMPTOMS OF DISEASE.

BY
SIR JAMES MACKENZIE, M.D., F.R.S., F.T.C.,
DIRECTOR OF THE ST. ANDREWS CLINICAL INSTITUTE.

WHEN we started the Institute for Clinical Research in St. Andrews we recognized that if success were to attend our efforts we must have a clear comprehension of our object, and a definite idea how that object should be attained. We define our object as the

Prevention of the Diseases that are Common amongst the People.

To understand how disease should be prevented it was necessary to know what are the diseases which are common among the people. On inquiry it was found that, except in a small percentage of cases, this knowledge was nowhere to be obtained.

Here, then, the first step to be taken was to know what the diseases are which we wished to prevent.

The next question was how to proceed to get this knowledge. The great majority of the sick suffered from complaints, and showed signs of ill health, but the disease was unknown. In a few cases the disease could be recognized, because medical knowledge had advanced so far as to

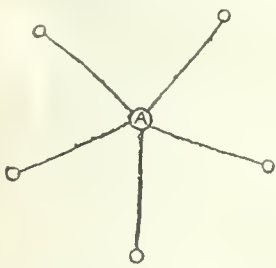

FIG. 1.

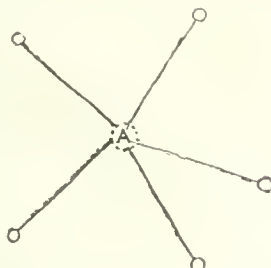

FIG. 2.

FIG. 1 represents a disease completely diagnosed, where A is the agent acting injuriously on the tissues and producing reactions or symptoms, which are represented by the circles at the periphery—as typhoid fever, or conjunctivitis due to a foreign body in the eye.

FIG. 2 represents a disease not fully diagnosed, where, while the symptoms are recognized, the injurious agent A has not been recognized, though its nature can be inferred, as in measles.

detect certain signs and symptoms which experience had shown to be due to definite causes. Seeing that the diseases we wished to prevent were for the most part unrecognizable, it would be futile to attempt to prevent them, so that it was manifest an undertaking must start with preliminary inquiry into the nature of the diseases.

Definition of Disease.

In order that our inquiry should be pursued in a logical and systematic manner, we sought to get a clear grasp of what we meant by disease. The definition of an abstract term such as disease would probably be given in different terms, according to the standpoint of the definer. After much consideration and discussion we analysed the phenomena in over 1,000 cases and worked out the following scheme, which revealed the present state of knowledge on the subject, and at the same time afforded a guide for our inquiry.

If we take a simple disease like conjunctivitis, where the cause can be ascertained, we find that the diseased state consists of a foreign body which injuriously affects the tissues, causing certain reactions or symptoms, as pain, lacrymation, redness, blepharospasm. Such a condition may be considered a complete diagnosis and can be represented by the diagram (Fig. 1), where A is the injurious agent and the surrounding circles are the reactions or symptoms.

We found in our inquiry that the complete diagnosis is possible only in a relatively few cases—where the injurious agent has been recognized as due to a foreign body or to a microbe, as in typhoid fever, pneumonia, diphtheria.

In some cases the reactions occur in such definite groups that they can be differentiated, and it can be assumed with

reasonable certainty that the disease is caused also by a microbe which has not yet been identified, as measles, small pox, rabies, etc. These are represented in Fig. 2, in which the injurious agent is represented by a dotted line.

There were other cases in which the group of symptoms were also capable of differentiation, but in which the nature of the injurious agent was unknown, or a matter of speculation, as in migraine, epilepsy, diabetes, etc. This is represented in Fig. 3, where a point of interrogation represents the injurious agent.

The bulk of patients suffer from diseases in which, so far, it has been found impossible either to recognize the agent or to arrange the symptoms into groups that permit of their clear differentiation from others that they resemble. The nomenclature of such conditions is usually based on the presence of a dominant symptom or of a number of symptoms associated with some organ, such as anaemia, neuralgia, neurasthenia, debility, disordered action of the heart, indigestion. The knowledge of the disease in those cases may be represented diagrammatically (Fig. 4) as a confused heap of symptoms in which it is not possible to obtain a suggestion as to their relation to a common cause.

To the latter group belong probably all chronic diseases, even though the ill health is definitely due to damaged organs which can be recognized by physical signs—as arterio-sclerosis, chronic heart disease, chronic kidney disease, and even consumption and cancer. The reason for including these is that they are probably secondary diseases, the original cause not being capable of recognition.

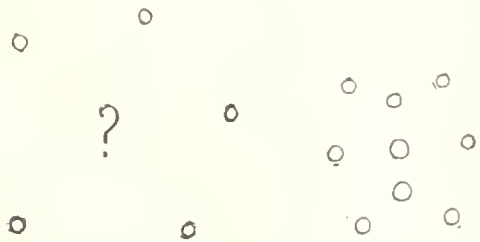

FIG. 3.

FIG. 3 represents a disease with a well-defined group of symptoms, but where the nature of the agent is not recognized—as migraine, convulsions.

FIG. 4 represents the vast majority of diseases, where a number of unco-ordinated symptoms are present with no recognizable cause.

FIG. 4.

The Relation of Symptoms to Disease.

This method of looking upon disease reveals not only the state of our knowledge of diagnosis, but gives a guide in research. It shows that disease is only revealed by the symptoms it produces, and that even in the few diseases where the nature of the agent is understood it can only be identified in the human body by its symptoms.

A consideration of the history of the recognizable diseases shows that the first step in research is to recognize the symptoms. The next step is to group them together, so that one group can be clearly differentiated from those that resemble it. By this method the clinical observer differentiates the disease, it may be, without recognizing the cause. Having reached this stage, he can present a clear-cut problem to, for example, the bacteriologist, who may complete the diagnosis by discovering the injurious agent. The symptoms of the majority of diseases have not yet been clearly differentiated, and there is little prospect of progress being made until this has been done.

This brief review of our present knowledge of disease shows that the chief aim of medical science—the prevention of disease—can never be achieved till we are able to recognize the diseases. Where success has been achieved and disease prevented, it was due in the first instance to the recognition of the symptoms. The clinical observer who obtained this knowledge succeeded because the symptoms were striking in character and easily recognized—as by the presence of a rash or eruption or other sign. It is reasonable to conclude that if we had a better understanding of the mechanism by which less obtrusive symptoms are produced we would get nearer to the detection of the agent producing them. When a person falls ill, the fact is made evident only by the symptoms,

so that the only way in which the disease can be detected is by the recognition of symptoms.

The study of symptoms has been carried on since the dawn of medicine, and from the early days additions have continually been made to their numbers, until to-day the number is so great that no one individual can recognize more than a fraction of them, and methods are ever being invented for the discovery of new symptoms. If our enterprise were but to seek for new symptoms, it would be in vain, for the addition of new symptoms would but add to the confusion of a subject already far too chaotic.

The Evolution of a Science.

All subjects that have attained the position of a science have passed through stages of which the collection of facts was the first. So long as these facts were unco-ordinated their accumulation tended to confusion, and there came to be recognized the need for an ordered arrangement based upon a law of nature.

The history of chemistry is an illustration. The appreciation of Dalton's atomic theory gradually enabled the mass of detail to be classified according to a law of nature. Not only this, but it opened up possibilities and gave guidance to further research, and so enabled the science of chemistry to make remarkable progress.

Symptomatology is in the same confused state as chemistry was before the recognition of the atomic theory; and it calls as urgently for a classification based upon some law of nature that reveals the mechanism of the production of symptoms.

The Classification of Symptoms.

Hitherto there has been no clear conception of the nature of symptoms, and the classifications that have been made have hampered progress and misdirected the course of research. Thus symptoms are usually described from the standpoint of the organ giving rise to them, and specialists devote themselves to the study of the symptoms of individual organs or systems. When a person falls ill nearly every organ of the body may be disturbed, and each specialist has no difficulty in detecting symptoms belonging to his particular branch. In consequence of this we find that confusion of diagnoses which results when a patient consults a number of specialists.

Another source of error arises from the fact that when one organ is diseased its impaired function is revealed not by the organ at fault but by its effects upon the other organs of the body.

It is now many years since I saw the need for a knowledge of the mechanism by which symptoms were produced. I have steadily pursued the subject, and several years ago I dimly recognized that there was some definite law governing this mechanism. I attempted a classification and I was able to group a number of symptoms according to their mechanism, such as a *structural group*, recognized by a physical sign, a *functional group* due to interference with the functions of an organ, and a *reflex group*, due to a peculiar stimulus setting up definite reactions. But there remained a large group, which I recognized somehow or other belonged to the last group, but their mechanism was not clear.

This was the state of knowledge when we began our inquiry. We recognized that it was useless to attempt a research into any particular disease until we had acquired a knowledge of the laws that underlay the production of symptoms, and to that end our chief endeavour was given. We met twice a week; at one meeting we discussed the nature of one particular symptom, and sought for an explanation in the daily routine of examining patients. At the other weekly meeting we discussed in detail the symptoms of individual patients.

The Law Governing the Production of Symptoms.

As time went on we got a better insight into one symptom after another, and we felt we were getting nearer the law of which we were in search, and gradually its recognition dawned upon us. At first we scarcely recognized it when it was put before us because of its extreme simplicity, for we found the law to be that the vast majority of the symptoms of disease are disturbances of normal reflexes.

I know quite well that no one who reads this will accept at present the view that this theory will do for clinical medicine what the atomic theory did for chemistry, but

I know equally well that when the method of applying it is understood its significance will be appreciated, and it will have a very far-reaching influence on the progress of medicine.

How the Theory was Discovered.

The discovery of this law is the outcome of a long and painstaking search with a definite object in view.

Shortly after entering general practice, over forty years ago, I was impressed with my ignorance of the diseases from which my patients suffered. In the majority the evidence of ill health was confined to the patient's sensations, which I could not interpret. Realizing this, I resolved to see if I could not improve my knowledge, and began to pay more attention to such signs as I could detect, and the principal sensations of which the patient complained. I had not gone far when I realized that these signs and symptoms were so numerous that I could only hope to investigate a limited number. But even when I had selected a few for particular observation I did not know what method to pursue. On reflection I decided upon concentrating my attention on two aspects: (1) *The mechanism by which a symptom was produced*; and (2) *the bearing the cause of the symptom had on the patient's future*.

Of these aspects the latter is, of course, of the utmost practical value to a doctor, and although under the term "prognosis" it has received perfunctory attention, I found that neither the manner in which the subject should be studied nor the individual whose opportunities fitted him for the task had been realized; but with that I do not deal here.

The study of the mechanism by which symptoms were produced led me into several different fields. There was, for instance, the pulsatile movements in the jugular veins and the liver, the movements of the heart in health and disease, and the mechanism of irregular heart action to be considered. I devoted several years to finding out the mechanism of these signs, and the results were an ample reward for the labour and time spent, and helped to make that revolution which has made of human cardiology a totally different subject from what it was when these researches were begun.

The study of the sensations of the patient was much more difficult. I began with the most clamant of all—pain. Hilton's book on *Rest and Pain* was the furthest step that had been taken, but valuable as it was it did not go to the root of the matter. For some years I made little progress—collecting isolated facts but unable to see any reasonable explanation for their causation. In 1888 Dr. James Ross published his article on referred pain, and I at once recognized that he had provided a hypothesis which not only helped to explain much that was obscure but gave a guide for carrying the subject further. In this paper he stated that pain, when arising in an organ, was felt in two ways—first by a pain in the organ itself, and second by a pain felt in the external body wall at a place remote from the organ. The first of these he called splanchnic and the second he called somatic.

I had already gone so far in my inquiry that I recognized the significance of his somatic or referred pain, but I was doubtful of his splanchnic, considering that it also was really referred. He used as an illustration the pain of gastric ulcer when limited to the epigastrium as being a splanchnic pain, but when I examined a patient with a gastric ulcer I found that on a deep inspiration, while the stomach descended, the pain remained fixed.

Though suggestive this was far from convincing, and I sought diligently for other signs, and in 1891 I found a sign which threw much light upon the matter. This was finding a large area of hyperalgesia of the skin over the liver in a patient after an attack of gall-stone colic. This led me to seek for cutaneous hyperalgesia in other cases, and I soon found that it was of frequent occurrence, particularly in affections of abdominal organs. It required, however, a long training to acquire the skill to detect it in many cases.

Shortly after this another sign was recognized—namely, the contraction of the muscles of the abdominal wall, due to disease of an abdominal organ. It had been recognized before, and spoken of as "protective rigidity," but its real nature and significance had never been understood. I watched how portions of the muscle wall of the abdomen would become hard and resistant during the course of a

disease, such as gastric ulcer, appendicitis, gall-stone disease, cholecystitis. I observed it disappear with improvement, until it was not evident, and I could recall it by gently rubbing over it. I noted in patients the sudden contraction of muscle that ensued under certain conditions. Thus, some of my patients described that on the onset of an attack of renal colic the testicle would be dragged up (by contraction of the cremaster muscle).

I described these symptoms of pain and hyperalgesia in consequence of disease of the viscera as a *viscero-sensory reflex*, and the contraction of the muscle as a *viscero-motor reflex*.

There was a large group of symptoms which occurred when patients fell ill from some obscure cause (as infection), such as the feeling of exhaustion, loss of appetite, breathlessness on exertion, palpitation, vomiting, mental depression. These had been vaguely described as toxic symptoms, and I had indeed described them as due to a hypersensitiveness of certain parts of the central nervous system, but I did not clearly realize the mechanism which produced them; this was the stage reached when we started the Clinical Institute, and the matter was summarized in an address I gave on the "Soldier's heart and war neuritis: a study in symptomatology."¹

The Application of the Theory.

In the description of the theory and its application which follows, some simple observations are given to show the manner in which certain reflexes are disturbed; while we have found it already of value in the interpretation of our patients' symptoms, we recognize that there is required a much better knowledge of reflexes before the theory can be used in a systematic manner. The illustrations therefore are merely to indicate how it may become of use.

While the stimulus and response parts of a reflex may often be recognized, the mechanism of that part of the reflex in the central nervous system is not yet quite clear. Consequently the diagrams of this part of the reflex do not pretend to represent the actual mechanism.

In attempting so to explain the theory that symptoms arise from disturbed reflexes as to carry conviction we recognize that we are handicapped in that what we take to be facts may not be accepted as facts by the reader, and it would take up too much space and time to give our reasons. When, for instance, I state that exhaustion of heart muscle produces pain and proceed to develop the argument in which that statement is accepted as a fact, the reader may not accept the statement. The observations on which that statement is based have been carried on for many years, during which patients have been watched and the circumstances provoking the pain have been considered, the gradual progress of the case observed, and the conditions at the *post-mortem* examination carefully noted. Another long series of observations have been made to discover the laws that govern the production of pain in all muscular organs—a research, indeed, in which we are still engaged, and which every day tends to confirm the view advanced here. In like manner, when I take it as a fact that exhaustion is due to a disturbance of a vasomotor reflex, it is not possible to give the long series of observations on which the statement is based.

Until we are able to publish the researches into these and other matters involved in this description, I would ask

the reader to assume that our facts are proven, so that the explanation of this theory may be understood.

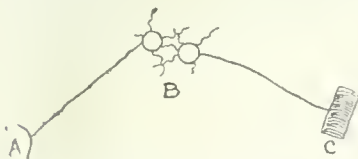

Description of a Reflex Arc.

In the reflex arc we recognize the following parts (Fig. 5). A. The receptor or place where the reflex is initiated.

An afferent nerve fibre conducts the stimulus to B, the nerve centre. Here the afferent nerve ends in a synapse with one or more nerve cells—the actual number and relationship varying in complexity. The nerve centre in turn sends an efferent fibre to C—the effector or structure, be it muscle or gland or centre of

consciousness, which gives the ultimate response characteristic of the reflex.

The whole of this arc is necessary for the production of a simple reflex. Symptoms, or, in other words, alterations in the reflex, may be referable to causes acting upon any part of the arc, but in practice they are found to be mainly confined to alteration in A, the receptor; B, the nerve centre; or C, the effector.

The Part of the Reflex in Life.

The whole economy of the body is built up of a system of organs whose activities depend on reflexes. A flood of stimuli is continually being poured into the system through the skin and special senses, and each stimulus produces a definite reflex on some part of the body. In the deeper tissues of the body stimuli are continually arising and being sent to different organs, which respond by some modification of their activity.

The sources of stimulation, therefore, arise in every part of the body. Organs that at one time are the source of stimulation become at other times the effectors. Thus, when pain is felt, the source (A part of the reflex) may be the peripheral distribution of any sensory nerve, while the brain is the organ which responds (the C part of the reflex). The different organs of the body during periods of activity and quiescence send out stimuli-producing reflexes which modify the activities of other organs—as the heart when it increases its activity in responding to a call for more blood, or decreases its activity in a cessation of effort.

The interplay of these reflexes results in the harmonious action of the organs of the body which we recognize as "health." The disturbance of one or more of these reflexes results in a disharmony which we recognize as symptoms of disease.

Methods by which Disturbed Reflexes are Produced.

There are two ways in which reflexes may be disturbed:

1. By the nature of the stimulus acting on the A part of the reflex arc, the impulse entering through the nervous system.
2. By altering in a positive or negative sense the receptivity of the B and C parts of the reflex, the agent (chemical or thermic) entering through the blood stream.

Disturbance of Reflexes due to the Stimulus Entering through the Nervous System.

The following observations sufficiently illustrate the mechanism by which this kind of disturbed reflex is produced.

Many years ago I had shown that the only serous membrane in which a sensation of pain could be produced was the visceral layer of the tunica vaginalis.

Observation 1.

Dr. Orr, in tapping a hydrocele, tested this statement and noted the sensitiveness of the parietal and visceral layers of the tunica vaginalis. He found he could scratch the parietal layer and the patient feel nothing, but when he touched the visceral layer with the trocar the patient (1) drew back, (2) felt severe pain, (3) became pale, (4) nauseated, and (5) collapsed.

Observation 2.

A man was seized with an attack of renal colic and suffered violent pain in the left side of the abdomen, with contraction of the muscles. He became pale, and sweat poured out; he vomited, and the pulse became soft, and he felt faint.

In Observation 1 the touching of the visceral layer of the tunica vaginalis was the stimulus at the receptive or A part of the reflex. Then followed a variety of responses or effects on the C part of the reflex: (1) A muscular response in the sudden drawing back of the body; (2) the sensation of pain the centre of consciousness, being the response part of the reflex; (3) pallor—a cardiac reflex—due to a stimulation of the vagus, which also probably caused (4) the nausea, and (5) collapse, due to a vasomotor reaction. In Observation 2 we have a similar series of reflexes, these being in addition, the vasomotor reflex causing the sweating, and the vomiting reflex.

Alteration of the Receptivity of the B and C Parts of the Reflex Arc.

The other method, by altering the B and C portions of the reflex arc, comes about through the circulation in the blood of certain agents which affect parts of the arc in a negative or positive way—that is, either increasing or

diminishing the intensity of the impulses during their passage from *A* to *c*.

The demonstration of the disturbance of the reflexes through the nervous system is readily understood from such observations as 1 and 2. The demonstration of the circulatory—chemical or toxic—influences is not so easy. Perhaps the best way is to consider the effects of certain drugs whose effects have been sufficiently observed.

Observation 3.—The Effect of Atropine.

An individual who receives a certain quantity of atropine may complain of impaired vision and palpitation. When examined he is found to have a dilated pupil and an increased heart rate, which is abnormally increased on effort.

Each of these effects is due to the drug blocking the passage of normal impulses at *c*. The pupil of the eye is maintained in an ever-varying balance between dilatation and contraction, responding with great sensitiveness to the stimulus of light. This is because of two reflexes, one presiding over the dilator muscles of the pupil and the other over the sphincter muscles. The atropine blocks the passage of the normal impulses to the sphincter at *c* and the balance is upset. The heart's activity is regulated in the same way by two sets of nerves, acceleration of rate by the sympathetic, and slowing of rate by the vagus. The heart is like the pupil, ever ready to respond to a demand for more or less blood from the tissues, according to their ever-varying activity. The atropine acts by paralysing the peripheral end of the vagus, or by depressing the *c* end of the reflex arc, and the uncontrolled sympathetic fibres cause the increased rate.

Observation 4.—The Action of Strychnine.

In the reflex action of muscles in causing the movement of a joint there occurs normally at the same time as the contraction of the muscles a relaxation of the opposing muscles. Thus in

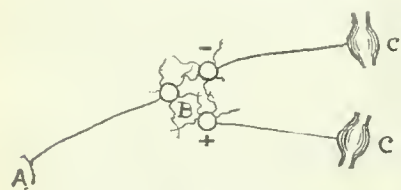

FIG. 6.—Diagram of a muscular reflex. The stimulus from *A* passes to *B*, where it affects the nerve cells supplying the muscles *c* and *c'*. In response to the stimulus the muscle at *c* contracts, while the muscle at *c'* relaxes. The signs + and - indicate the different actions.

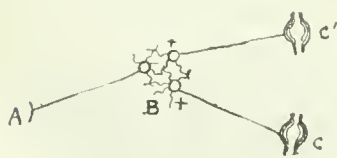

FIG. 7.—Diagram illustrating the effects of strychnine. The response from the stimulus arising at *A* affects the cells at *B* differently, so that while the muscle at *c* contracts the muscle at *c'* does not relax, but also contracts. This is shown by the - sign in Fig. 6 being now a + sign.

strychnine poisoning. It is to be noted that neither the strychnine nor the toxin in rabies can by themselves initiate a stimulus for the production of a reflex—this arises always from some part of the body through the *A* portion of the reflex arc, as at the skin. This fact shows that the drug does not cause convulsions, but only modifies the reflex in such a way that the stimulus from *A* produces the convulsions.

These methods of action probably explain the action of all drugs or toxins which are supposed to act on centres. A great number of drugs are credited with causing vomiting for instance, but the manner in which they act is to render the *B* or *c* portion of the arc more susceptible to a stimulus so that a normal stimulus passing into the nervous system affects certain reflexes which have been rendered unduly sensitive.

The following observation shows how a normal act can affect the reflex at *B* when it is rendered hypersensitive by an agent such as a drug.

Observation 5.

A man with a regular heart, after I had given digitalis, showed irregularities which a graphic record demonstrated to be due to the dropping out of ventricular systoles, the auricular rhythm being unaffected. The digitalis was stopped, and in a few days the heart's rhythm became quite regular, the ventricular systoles having ceased to drop out. Commenting on this fact to the patient, he said he could bring the irregularity back, and I asked him how, and he replied, "By swallowing." I requested him to swallow, which he did, and a ventricular systole dropped out. I took a long tracing, and when he did not swallow the rhythm was regular, but as soon as he swallowed a beat was missed. This was repeated a great number of times. Four days later the heart was quite regular, and swallowing had no effect upon the heart's rate.

Observation 6.

A woman, aged 52, experiences attacks in which she becomes prostrated, suffers severe pain in the head, and vomits. If she lies quite still she does not vomit, but if she is startled by a noise—such as the banging of a door or ringing of a bell—or if she smells tobacco or cooking, vomiting occurs.

In this condition there is manifestly a hypersensitive condition of the *B* part of the reflex arc, but it is to be observed that vomiting occurs from a stimulus from the periphery, just as the convulsion in rabies and strychnine poisoning.

The Added or Reinforced Stimulation.

In the production of reflexes in disease the reflex often takes place with unusual ease or facility, a slight stimulus producing an exaggerated reflex or calling into play an unusual reflex, as in Observation 5. The reason for this is that the disease disturbs some parts of the reflex arc rendering them more or less susceptible to stimulation. This may happen in several ways.

In certain forms of visceral disease certain areas of the skin or other tissues of the external body wall show an increased susceptibility to stimulation. Thus, when pressure is applied to the skin of such a strength that in the unaffected part it produces only the sensation of touch or pressure, it produces in these hyperalgesic areas the sensation of pain. The explanation of this disturbance of the normal reflex is that already a stimulus is affecting the arc from the diseased organ *A*, and the added stimulus of pressure *A'* is sufficient to produce pain (Fig. 8).

The contraction of the muscles of the abdominal wall in disease of abdominal organs (the "viscero-motor reflex") is but an exaggeration of the normal reflex which maintains the tone of these muscles. If the gradual disappearance of these contractions be observed it will be found to merge into that state of resistance which we recognize as tone in these muscles, so that the contraction in visceral diseases is but an exaggeration of the normal tone.

The increased sensitiveness which is shown by hyperalgesia of the tissues of the external body wall is capable of giving rise to pain from a stimulus reaching the central parts of the arc.

Observation 7.

A man with advanced aortic disease suffered from attacks of angina pectoris. He had a diseased tooth, which caused a slight degree of pain. During the attacks of angina pectoris, in addition to the pain in the chest and left arm he had pain along the jaw, but the pain was always most severe around the diseased tooth.

In this instance the diseased tooth kept up a continual irritation of the *A* part of the sensory reflex, and the pain would become more severe when pressure was made on it in chewing, the reflex arc being disturbed by an increase of the stimuli at *A*. During the attacks of angina pectoris pain was felt along the jaw—where there was already a disturbed reflex—this additional stimulus reaching the arc at *B* produced an increase of the pain, or, in other words an increased response, at *c*.

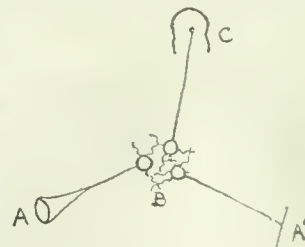

FIG. 8.—Diagram to illustrate an added or reinforced stimulus. The presence of disease at *A* (say gastric ulcer, a diseased tooth) keeps up a persistent irritation at *B*, so that a stimulus from *A'* (the skin or other organ) not sufficient to cause pain by itself, affects the irritated cells at *B* and produces pain (see also Observations 5, 6, 7).

Observation 8.

A man suffered from jaundice with severe attacks of gall-stone colic for several days. The skin of the upper part of the abdomen on the right side was very tender on pressure hyperalgesia. The pains suddenly ceased and a gall stone the size of a bean was passed by the bowel. The hyperalgesia of the skin persisted, but he suffered pain over the hyperalgesic region on taking food. When the hyperalgesia disappeared he suffered no pain on taking food.

Here, as in Observation 5, a normal stimulus (resulting from the taking of food) on entrance into the central nervous system affected a hypersensitive part of a reflex.

Balanced Reflexes.

There are a great many different kinds of reflexes, some so obscure that their mechanism is not clear. There is one form which from its simplicity illustrates the theory of disturbed reflexes as the basis of symptoms. This is the kind which might be called balanced reflexes, where two systems of reflexes mutually react. This was seen in the description of the reflex contraction of muscles, when at the same time one set of muscles contracts another set relaxes, where strychnine and the toxins of rabies and of tetanus disturb this balance (Figs. 6 and 7). It is also shown in the pupil, where normally the movements of the pupil are exquisitely balanced by the nerves supplying the dilator and sphincter fibres, and where atropine upsets this balance by paralyzing the sphincter fibres. It also occurs in the heart, where the play between the accelerator and depressor nerves of the heart results in the delicate regulation of the heart's activity in response to stimuli from the other organs of the body.

In many illnesses the balanced reflex is upset, so that we find the pulse rate a valuable indication of the patient's state. In most toxic cases the rate is increased, possibly by the excitation of the accelerator (sympathetic) part of the reflex. In some cases the toxin stimulates the depressor part, as in typhoid fever, and the effect upon this part of the balanced reflex is seen in certain diseases where the heart's rate becomes very slow, as in the following observation.

Observation 9.

A man 50 years of age began to suffer from sudden attacks of loss of consciousness of brief duration. His pulse was found to be slow, and records—graphic and electrographic—showed that his ventricle was responding only to every second auricular beat. As this is typical of one kind of an over-action of the vagus, an attempt was made to remove this by atropine, which paralyzes the peripheral end of the vagus. A hypodermic injection of one-fiftieth of a grain of atropine was followed in ten minutes by the appearance of more beats, and in thirty-five minutes the ventricle responded to every auricular systole.

In this instance the disturbed reflex was due to an over-action of one part of the balanced reflex (the vagus) and the removal of this over-activity at the c portion of the arc by the atropine restored the heart to its normal rhythm.

An example of the disturbance of the balanced reflex, which not only illustrates the mechanism but throws light on a matter of real importance in practice, is afforded by the variation in the heart rate occasioned by the act of respiration. In differentiating the different forms of heart irregularity I recognized one form common in the young, which I called the youthful type of irregularity, and demonstrated that it was produced by the breathing; the heart increased in rate during inspiration and decreased during expiration. This variation was more marked if the individual breathed slowly and deeply.

On inquiring into the significance of this form of irregularity I found it present in young people in perfect health. I found it disappeared when any febrile illness caused an increase in the heart's rate, and it returned when the fever fell and the rate returned to normal. I have used this irregularity for over twenty years as a guide in doubtful cases after recovery from illness, looking upon its presence as a proof that the disease had departed, and that the heart was free from any active process. This view is now justified. Under ordinary circumstances the balance between the accelerator and depressor nerves is so even that a stimulus such as breathing disturbs the balance. The presence of a toxic agent affects the reflex, causing an increase in the rate, so that the slight stimulation from the act of breathing no longer has any effect, and hence the reappearance of the irregularity at the termination of a febrile illness.

The Disturbed Part of the Response.

The tendency to heart-block by stimulating the vagus (as by the use of digitalis) is more apt to occur when the bundle connecting the auricle and ventricle is damaged, and the question arises, Is the effect at c which produces heart-block due to an increase of the vagal activity or an increased susceptibility of the responding organ—that is, the auriculo-ventricular bundle? That the reflex may be impaired by the diminished susceptibility of the recipient organ at c can be inferred from the following observation:

Observation 10.

A man 68 years of age consulted me because he had found that on making a considerable effort, as running upstairs, his pulse, in place of increasing in rate, fell to nearly one-half its rate. I tested him, and found that this was so: I considered that the bundle which conveys the stimulus from auricle to ventricle was damaged, so that while the damaged bundle could convey a stimulus at the rate of 60 or 70 times a minute, it failed to do so when the rate became higher. Subsequent records, graphic and electrographic, confirmed this view.

In this instance the normal balance of the reflex between the augmenting and inhibiting nerves to the heart is disturbed by the damage to the recipient organ.

Multiple Stimuli and Multiple Responses.

The response at c may be due to stimuli originating at different places and in different ways. Thus an abdominal muscle may contract in response to a stimulus from the brain, or from the skin, or from the movements of respiration, or from the movements of the body, or from a visceral stimulus, as in Observation 2.

A single stimulus can give rise to a number of responses—indeed, most stimuli do; we have seen that a entaneous reflex giving rise to a movement of a joint does so by the contraction of one group of muscles and the inhibition of another group, while Observations 1 and 2 showed that in response to a stimulus a number of reflexes followed.

Multiple Reflexes.

During ill health the patient may complain of a number of symptoms, and the doctor may detect a number of signs. This is due to the fact that the agent which causes ill health disturbs a great many reflexes. To look at these signs and symptoms, each one recorded as an isolated fact, presents such a confused picture that a coherent description of the patient's condition cannot be given. When the individual reflexes are recognized, then the symptoms can be grouped upon a rational principle.

This plan of analysis can be employed in studying the reflexes produced by the impaired functions of organs, or by the specific reaction to the toxins of disease, as well as to drugs, in the manner already described.

The Disturbed Reflexes due to Organic Disease.

One essential question in cases of diseased organs is their functional efficiency. When all the organs are functioning in a normal manner the reflexes pass unnoticed by the individual. When a failure of function takes place the reflexes are disturbed and symptoms appear. It is difficult to recognize the real source of a reflex, for many organs when they fail to function in a normal fashion do not themselves show the signs of failure, but the signs are shown by other organs that are deprived of the material the being of which contributes to the economy.

While the failure of each organ will give rise to different reflexes the fundamental principles governing the production of the symptom will be the same.

The Disturbed Reflexes due to Heart Failure.

The symptoms produced by heart failure offer a good illustration, as they have been worked out in some detail.

When a healthy individual engages in violent physical effort he will in time produce exhaustion of the heart, so that it no longer supplies sufficient blood to the organs and tissues, and the individual suffers distress. The same thing happens when an individual with a diseased heart undergoes an effort which leads to exhaustion, only in the second instance the amount of effort is less. The signs of heart failure are those of distress and are not to be found by the examination of the heart but by effects of an insufficient supply of blood to other organs. This is well recognized in advanced heart failure when there are

in addition to distress on effort, the physical signs of dropsy and an enlarged liver.

In the great majority of people who suffer from heart failure these physical signs never appear. In them the heart failure is made manifest by a limitation in their response to effort; they are pulled up by distress in some effort they were wont to perform in comfort. This is because of certain reflexes that are set up by organs which suffer from an insufficient supply of blood. The reflexes are of a nature that produce distress of such a clamant kind that cessation of effort is called for. They are mainly of two kinds—the distress associated with (1) breathlessness and (2) pain in a distinctive region.

In healthy people the most frequent evidence of heart exhaustion (as in running) is breathlessness and the accompanying sensation of tightness at the throat and a sense of suffocation. Occasionally there is also a sensation of constriction of the chest with pain across the chest.

What happens in a healthy person is also what happens in one with a weak and diseased heart, one difference being that less effort produces the distress in the latter case and another that pain is a fairly frequent cause of distress.

The mechanism of these two reflexes is quite distinct. Respiratory distress is the outcome of a disturbance of the respiratory reflex on account of the heart being unable to supply purified blood to some part of the respiratory system. I do not discuss further this mechanism here, as it would lead us too far, but everyone recognizes that breathlessness is a sign of heart exhaustion and that it is due to a disturbed reflex.

The other reflex, of which pain is the dominant feature, is a reflex arising from exhaustion of the heart muscle itself. The pain is often accompanied by other reflex signs, as contraction of the intercostal muscles producing the constriction of the chest—sometimes of such extreme violence as to be more dreaded than the pain. Sometimes the mouth fills with saliva, and the pain may be felt not only in the chest but in the arms and along the jaw (Observation 7). These are multiple reflexes comparable with that described in Observation 2.

Observation 11.

A man 68 years of age complains of breathlessness on going up a hill or stairs. Also of pain across the chest, on effort under certain conditions, such as walking out on a cold day or after a full meal. The pain across the chest is preceded by a sense of tightness, or constriction, such as used to pull him up when running a race in boyhood. These signs of limitation have come on gradually, and he noticed his limitation fifteen years ago. There are no physical signs of disease, except some arterial degeneration.

This account is one common to a great many people, in whom the coronary arteries become diseased so that the heart muscle does not receive an adequate supply of blood.

In this case the heart in supplying the active muscles of the legs fails to supply other parts with enough blood, and amongst others the respiratory system is affected, and gives rise to the complex reflex which is called breathlessness. At other times the heart muscle does not receive a sufficient supply of blood, and it gives rise to its peculiar reflex—pain and contraction of the muscles of the chest wall.

In heart exhaustion, then, we have two prominent reflexes—the one arising from a deficient supply of blood to the respiratory organs, and the other arising from exhaustion of the heart muscle. Which of these reflexes first appears on heart exhaustion depends on whether the respiratory or cardiac reflex is first called into play. In the case quoted, under certain circumstances it was the respiratory, and under others it was pain. Occasionally they may both appear.

In certain cases the respiratory reflex is readily produced, as in auricular fibrillation—a condition in which pain is infrequent and rarely severe, while in diseases which limit the supply of blood to the heart muscles pain is readily induced. In the following instance the reaction of the reflex to the different heart states is brought out.

Observation 12.

A man 66 years of age consulted me for pain on walking. The pain at first was only produced by walking, and only on certain occasions—mostly on walking after a meal. The pain was situated across the chest, and was accompanied by a gripping sensation. As years passed the pain became so easily provoked that walking under any circumstances would cause it. The

heart was normal in size and the rhythm of the heart normal. One day, when 72 years of age, he called to see me, and said that until recently he could walk 200 yards before the pain compelled him to stop. Now he can only walk 100 yards when he is pulled up, not by pain but by breathlessness. Indeed, since this breathlessness occurred he had not suffered from pain. On examination I found the heart was irregular in its action, the irregularity being characteristic of that due to auricular fibrillation.

This is not an isolated instance, as I have had several cases with a somewhat similar history, but explains an observation I made many years ago, that people with auricular fibrillation do not suffer from severe attacks of angina pectoris.

The Effects of Drugs.

It has already been shown that drugs act by causing a disturbance of reflexes. This way of looking at the action of drugs explains much that is obscure in pharmacology, as the following observation shows.

For a long time it was recognized that digitalis acted in a remarkable manner in some cases of rapid pulse in reducing the rate, while it had no effect in other cases. It was never understood why there should be this difference. I found out about fifteen years ago that in the cases in which it had this slowing effect the heart was regulated by abnormal rhythms—mainly that abnormal rhythm due to the condition now recognized as auricular fibrillation. I have attempted many times to reduce the increased rate of the heart when the rhythm was normal, and invariably failed. I speculated for a long time as to the cause of this difference, but never understood it till the theory of disturbed reflexes made the matter plain.

In infectious diseases—as pneumonia, measles, etc.—the balanced reflex that moderates the heart's action is disturbed by the toxins of the causal agent of disease, so that the rate of the whole heart is increased.

In auricular fibrillation this reflex is not disturbed. When the rhythm is normal the ventricle contracts only to the stimulus that arises from an auricular systole. In auricular fibrillation there is no rhythmic contraction of the auricle, but a continuous fibrillary twitching of the muscle, so that in place of the regular stimulus from the contracting auricle there is a shower of weak stimuli which assail the conducting system between auricle and ventricle, and cause the rapid ventricular rate. Not only is there this difference in the cause of the increased rate, but there is a difference in the condition of the cardiac reflex. In rapid pulse with the normal rhythm the reflex is disturbed by the toxins of the diseased state, so that the digitalis can produce no effect. In auricular fibrillation the reflex is unaffected, so that the digitalis can act upon the vagus portion, and in doing so depresses the conducting mechanism to the ventricle and renders it not so susceptible to the numerous stimuli from the auricle.

The Analysis of Symptoms.

In many diseases all the symptoms on which a diagnosis is based are reflex in origin—in some the reflexes are disturbed by the entrance of the stimulus through the nervous system, and in others the disturbance is through the circulation. To the former belong the symptoms of such diseases as gastric ulcer, renal calculus, gall-stone disease, where the symptoms are of the type described in Observation 2. The symptoms in infections are due to the disturbance of the reflexes through the circulation, as influenza, malaria, typhoid and typhus fevers, measles, and abscess formation, apart from the swelling.

In some diseases we get a mixture of both kinds of reflexes, as in appendicitis, where there is not only the local pain and tenderness of the tissues of the external body wall, with contraction of the muscles of the abdomen, but the feeling of exhaustion, rapid pulse, tendency to vomit. In cholecystitis we get a similar complex.

The need for the more accurate recognition of symptoms is seen when it is considered how difficult it is to diagnose even such seemingly simple affections as gastric ulcer and appendicitis. Though surgeons have been operating for these complaints for many years, the most experienced recognize that in many cases they find they have been mistaken in their diagnosis. This is due in a great measure to the fact that the nature and mechanism of the symptoms of these diseases have never been understood, and the symptoms were never clearly differentiated from those of other diseases which they resemble.

It will thus be seen that symptomatology is like chemistry, where the combination of elements results in the production of a great number of compounds bewildering in their variety. Nevertheless, as in chemistry, when they are subjected to strict analysis they can be resolved into their component elements. When the analysis of symptoms is studied as fully as the analysis of chemical compounds has been studied, then it will be possible to group the disturbed reflexes in an orderly manner. The next step then will be to find out the agents capable of provoking the different reflexes, so that we get nearer to the immediate cause of disease.

The employment of this method of investigation is but a return to those methods of clinical research which were so fruitful in their results in the past, especially during the early half of the nineteenth century. To realize how great the progress was during that period we have to consider the discoveries associated with the names of Addison, Bright, Graves, Adams, Stokes, Cheyne, Paget, Hodgkin, and Jenner. These observers employed the most useful of all weapons in research—the trained senses. What we aim at is to recognize the methods which these great observers employed, and by improving and refining their methods restore clinical medicine to the van of research.

Structural and Functional Symptoms.

A certain number of symptoms are due to structural changes and functional derangements. These are generally shown by physical signs, and are due to departures from the normal in various ways, as in alteration in the size and shape and consistence of organs, changes in the colour, as pallor, modification of the sounds of the heart and lungs. These are not dealt with here, but will have to be reconsidered in view of this theory of disturbed reflexes, because many apparently structural and functional signs are really disturbed reflexes, or are produced by disturbed reflexes.

A Preliminary Note

ON

THE HISTO-PATHOLOGY OF EPIDEMIC (LETHARGIC) ENCEPHALITIS.

(With Special Plate.)

BY

C. DA FANO, M.D.,

LECTURER IN HISTOLOGY.

(From the Physiological Laboratory of King's College, University of London.)

INTRODUCTORY.

In a previous communication on the same subject published in collaboration with Miss Helen Ingleby, M.B., mention was made of a granular, pigment-like material occurring in the nerve cells of regions of the central nervous system where brown or black pigment is not usually found. It was also pointed out that in certain nerve cells small round or oval bodies had been detected, in the middle of which a granule could be seen. The optical impression of such an appearance, when present in Bielschowsky or Nissl preparations, was that of a sort of whitish halo surrounding each granule.

When that note was written no more detailed description of these pictures was given, both because it was meant to be only a short comment on a demonstration of preparations and because I was still uncertain as to the significance of such appearances. It was only later on that a careful examination of a great number of specimens convinced me that I had under observation something not, as far as I knew, hitherto described either in epidemic encephalitis or in other diseases of the central nervous system. As, however, the doubt of an optical illusion could not be entirely dispelled, no further communication was made on the subject, and I waited for an opportunity of somehow strengthening my conviction. This presented itself under the form of a few preparations I was able to obtain recently in Paris through the kindness of Dr. H. Durand, Chef de laboratoire of Professor Netter of the Hôpital Trousseau, and of Dr. Trétiakoff, Chef de laboratoire of Professor P. Marie at La Salpêtrière.

Though many of my doubts are still present, the new

facts observed are, in my opinion, such as to require control from those interested in the pathology of epidemic encephalitis. I propose, therefore, to give now a brief description of the already mentioned appearances and of the more recently observed facts, reserving any further discussion about the occurrence of the granular, pigment-like material for another paper.

FIRST HISTO-PATHOLOGICAL FINDINGS.

A fairly good idea of the appearances to be described is given by Fig. 1 (special plate), which is a photographic reproduction of a coloured drawing † made from a toluidine blue preparation of material fixed in alcohol and embedded in celloidin.

This large nerve cell was seen in the lower part of the medulla oblongata, near the middle line, a little ventrally to the nucleus of the hypoglossus, of the first case of epidemic encephalitis published in collaboration with H. Ingleby. As clearly shown in the figure, the Nissl substance has undergone an almost complete process of chromatolysis, all that remains of it being still visible at the edges of the cytoplasm and near the nucleus, which, though retaining its form, has become shifted to the periphery of the cell body. The whole of the cell body is beset with a great number of granules easily distinguished in the preparation because of their blue stain contrasting with the purple of the fundamental cytoplasmic framework. The granules are found in the deep as well as in the superficial parts of the cytoplasm, and nearly all of them are surrounded by a minute light area which under moderate magnification looks like a halo, but under very high power and proper illumination appears as a very delicate, though sufficiently well defined, body, whitish or slightly bluish in colour, and irregularly round or oval in form. As a rule there is one granule in each body, though in some of them two granules, arranged like diplococci, can be observed. Most of the bodies are discrete, and only a few appear united in dumbbell-shaped forms. The granules measure about 0.4μ , their surrounding light areas from 1.4 to 1.8μ in diameter.

These are the appearances which repeatedly attracted my attention. For the sake of brevity they will henceforth be spoken of as "minute bodies," comprising in this term also the granules which appear to occupy their centre. It must be pointed out here that specimens as plain as that shown in Fig. 1 are very rare. In most instances the "bodies" are seen in altered nerve cells, together with a variable quantity of granular material which becomes stained by toluidine and polychrome-methylene blue in various shades of green. This is mentioned both because it may help other investigators in their search for the "bodies," and because it shows that their recognition is not hampered by the presence, within the nerve cells, of a granular material with which they seem, however, to have some relation.

A good instance of this is given in Figs. 2 and 3, which are likewise photographic reproductions of coloured drawings, the former being made from a toluidine blue, the latter from a polychrome-methylene blue preparation. The large nerve cell shown in Fig. 2 was found in the reticular formation of another section of the same medulla oblongata from which Fig. 1 was drawn. The diseased condition of the cell is clearly proved by the advanced chromatolysis, deformation, and peripheral shifting of the rather opaque and dark nucleus. The middle parts of the cytoplasm are occupied by a number of granules which in the preparation were stained a yellowish-green. Some of them appear here and there surrounded by a very small light area which, up to a point, imparts to them an aspect similar to that of the "minute bodies" which are particularly noticeable in the peripheral portions of the cytoplasm. These do not differ as regards form, staining properties, and situation, from those shown in Fig. 1. Outside the nerve cell two other "bodies," identical with these situated within it, can be recognized on the top of small fragments of protoplasmic material the exact nature of which could not be ascertained. In the same Fig. 2 another nerve cell has been drawn, showing for the purpose of comparison a common process of vacuolization.

The two nerve cells shown in Fig. 3 were drawn from the layer of small pyramids of a section of the first frontal

† All figures illustrating this paper were drawn by Mr. W. Pilgrim with the help of the Abbe-Zeiss camera lucida, comp. oc. 8 K, obj. 2 mm. Z., drawing sheet at the level of the microscopic table.

* Towards the expenses of this research a grant was made by the British Medical Association.

convolution from the alcohol material of the second case of encephalitis published in collaboration with H. Ingleby. Both of them have undergone a more or less advanced process of vacuolization, the vacuoles having been probably occupied by some fatty-like material dissolved by the alcohol fixation and successive treatment for embedding in celloidin. In the smaller cell a few typical "minute bodies" can be seen; in the larger one it is easy to recognize, beside the "bodies," small clumps of a granular material, stained a dark green in the preparation, and also surrounded by a light area similar to that which characterizes the typical "bodies."

FRESH EVIDENCE.

Investigations had reached this stage, but no further progress had been possible, particularly because all attempts to obtain a differential or at least more defined stain of the "bodies" had failed to give satisfactory results. The same can be said of the method commonly used for staining bacteria, their spores and capsules. The question was therefore left in abeyance until the opportunity arose of meeting Netter in Paris. During the conversation we had on the subject the following points were particularly emphasized by him: (1) The similarity existing in certain respects between epidemic encephalitis and certain forms of sleeping sickness on the one hand and rabies on the other. (2) The involvement in almost all cases of epidemic encephalitis of the salivary glands, a fact which he and Dr. Durand could support both from clinical and histo-pathological points of view. (3) His conviction that the direct etiological factor of the disease ought to be looked for in some agent similar if not akin to the Negri bodies.*

Of the preparations shown to me by Durand some were of nervous tissue, and on looking at  I had the rather vague impression of seeing within the nerve cells bodies which reminded me of those seen in my own preparations. Other specimens were from a salivary gland of an acute case of the disease, and these clearly showed in the interstitial tissue zones of small-celled infiltration very similar to that one meets with in the nervous tissue from cases of epidemic encephalitis.

As I was much interested in such an observation Durand presented me with two slides, on each of which were stuck three unstained paraffin sections of this salivary gland. When back in my laboratory the slides were cut in such a way as to obtain six separate preparations, which I stained with toluidine blue, polychrome-methylene blue, Weigert's iron haematoxylin, haematoxylin and eosin. In the areas of small-celled infiltration of three of them "minute bodies" were found similar to those detected by me in the central nervous system. The granules were stained either blue or blue black according to the method used; their surrounding areas had again the same whitish or slightly bluish appearance as above.

As seen in Figs. 4 and 5 the dimensions only of some of the central granules are somewhat larger than those of the granules noticeable in most of the "bodies" seen both in these specimens and in the nervous tissue. This difference has been a little emphasized in the photographic reproductions illustrating this paper by the fact that Figs. 1 and 2 have had to be reduced by two-tenths, while all others are of the same size as the original drawings. It is interesting to note that some "bodies" are situated within the cytoplasm of the infiltration cells while others lie free in the tissue, or, as in the case of the two extracellular forms shown in Figs. 2 and 5, they appear situated on the top of or attached to some protoplasmic material of not quite definite nature.

The purpose of my visit to La Salpêtrière was to see the preparations of epidemic encephalitis of Marie and Trétiakoff, but particularly "les volumineuses granulations entourées chacune d'un halo clair" described by them in the nerve cells of the substantia nigra, as well as the "inclusions homogènes dans le protoplasme de volumineuses cellules nerveuses du Noyau Rouge," also observed by them in their case No. 3. It is outside the province of this paper to enter into a discussion of the significance of these inclusions, particularly of the "volumineuses granulations," considered by the authors as a phenomenon "analogue à celui décrit par Alzheimer sous le nom de dégénérescence graisseuse à gros grains,"

but it should be noted that the fact corresponds to the description given by the authors, though the explanation might perhaps be different.

At La Salpêtrière both Trétiakoff and I looked for the "bodies" in the preparations kindly shown to me by him; but as nothing clear could then be found he gave me the following polychrome-methylene blue specimens for further investigation: (1) A normal preparation of the mid brain of an individual of about 40 years of age; (2) two sections—one of the optic thalamus and one of the mid-brain—of a case (Shibler) who had died in consequence of a relapse of the malady; (3) one section of the optic thalamus of an acute case (Baudeloque).

In the normal preparation, just as in my own control specimens, I failed to find anything resembling the "bodies." The section of the optic thalamus of the case Shibler was spoiled on the journey, and no use could be made of it; but in the grey matter surrounding the Sylvian aqueduct of the mid-brain section of the same case a few nerve cells were found the protoplasm of which was beset with small clumps of granular, pigment-like material. These had stained a yellowish-green and could be distinguished with sufficient ease from a few "minute bodies" identical with those seen in my own specimens. The preparation of optic thalamus of the acute case (Baudeloque) was also damaged during the journey, but it could be dismantled and retained with toluidine blue. In this specimen, in which the small-celled infiltration was of extreme intensity, neither pigment-like material nor blue granules could be found within the nerve cells, but "bodies" similar to those observed in the salivary gland were seen scattered in the nervous tissue, particularly near areas of perivascular infiltration (Fig. 7). In a few places forms occurred of which the central particle appeared to consist of two granules arranged in pairs as described above, but in this case one only of them was stained blue, while the other had taken a metachromatically red tinge. In regard to the peculiar tetragonal form shown in the same figure and consisting of two relatively larger purple-red and two relatively smaller blue granules, I think it advisable for the time being to reserve any judgement.

GENERAL CONSIDERATIONS.

It is evident that the possible value of my observations is, in great part, connected with the fact that they were made on varied material from different cases. Indeed, it is only the knowledge of the presence of the "minute bodies" within the nerve cells that has made it possible to recognize them outside the nerve cells in the nervous tissue, as well as within and without the cells forming the small-celled infiltration of the salivary gland specimens. On the other hand, this last observation, which by itself would be worthless, has given to my old finding a fresh significance. Of course, the possibility remains that the "bodies" seen in my specimens and in those for which I am indebted to Dr. Durand and Dr. Trétiakoff might be different, in spite of the similarity in aspect and staining properties. But if so, two different suggestions ought to be put forward to explain the presence of peculiar "bodies" in tissues more or less affected by the same disease. And this seems to me the chief point to be borne in mind: the pathological process underlying these observations being the same, so ought their explanation to be.

With this object in view the following three suggestions seem to me worth briefly considering: (1) That the bodies are the result of an optical illusion; (2) that the granules alone are either bacteria or products of a cell degeneration, their bluish or whitish haloes being again an illusion produced either by light or by vacuolization; (3) that the "bodies" are appearances directly due to the presence in the tissues of an agent, cause of the disease.

As to the first supposition, it has already been said how and why it has been the cause of considerably delaying the publication of this paper. However, I wish to point out here and now that such a suggestion could explain perhaps some of my recent observations and the bluish areas surrounding each granule in evidently diseased nerve cells. But this, in any case, only up to a point, as neither pigmented nor vacuolized nerve cells in normal or pathological conditions ever give such a complete illusion, even if highly magnified and looked at by very powerful artificial light. Moreover, some other suggestion ought to be put forward to explain the occurrence within nerve cells of granules which, according to their staining properties,

* Professor Netter and Dr. Durand have kindly consented to the publication of the above statement.

C. DA FANO : THE HISTO-PATHOLOGY OF EPIDEMIC (LETHARGIC) ENCEPHALITIS.

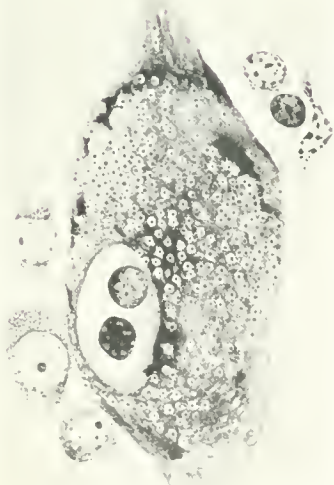

FIG. 1.—Large nerve cell beset with the "minute bodies" described in the text.

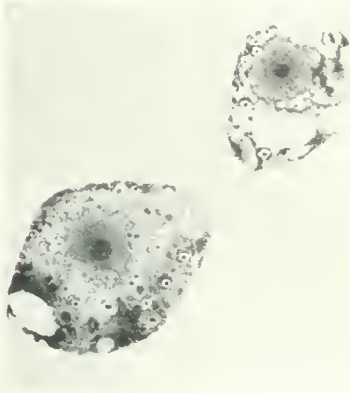

FIG. 3.—Two nerve cells from the cerebral cortex, the smaller one with "minute bodies" only; in the other both "bodies" and small clumps of granular material are shown.

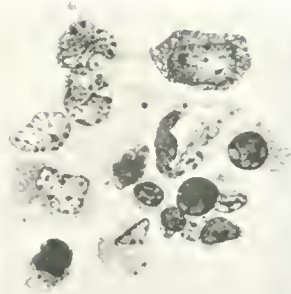

FIG. 4—"Minute bodies" among and within the infiltration cells of a salivary gland from an acute case of epidemic encephalitis.

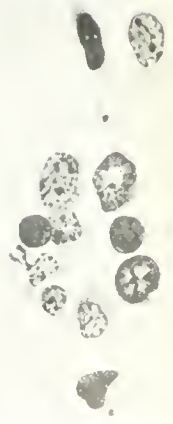

FIG. 5.—Somewhat larger "bodies" seen in another place of the same specimen as Fig. 4.

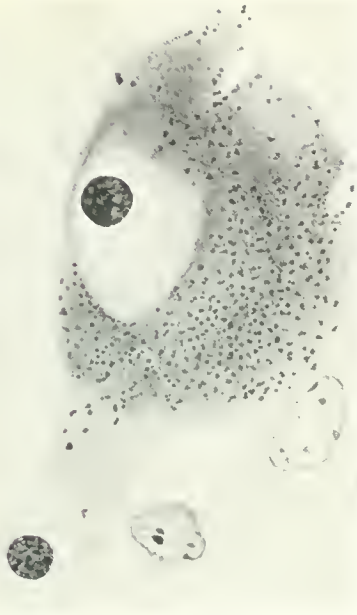

FIG. 6.—Large nerve cell with granular pigment-like material and a few "minute bodies." From the grey matter surrounding the Sylvian aqueduct of a mid-brain preparation of C. Tyebkoff.

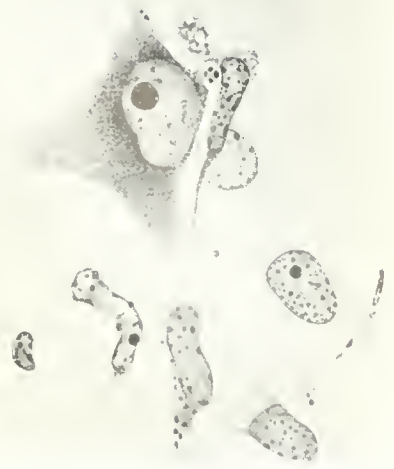

FIG. 7.—"Minute bodies" and a larger tetragonal form seen in the optic chiasm of an acute case of the disease.

FIG. 2.—Nerve cell with "minute bodies" and granular material. In the other nerve cell a common process of vacuolization is shown.

R. OLLERENSHAW: ROTATION-DISLOCATION OF THE ASTRAGALUS.



FIG. 1.



FIG. 2.



FIG. 3.



FIG. 4.



FIG. 5.

J. T. McAUSLIN: "HARLEQUIN FOETUS" (HYPERKERATOSIS CONGENITALIS).



are to be considered as formed either by chromatin or by a similar material.

This takes us to the second supposition, about which, besides some of the reasons just mentioned, I think it useful to remark that bacteriological investigations have been attended, for the present, by negative results, and that, as far as I know, no nerve-cell degeneration has been described resembling the appearances shown in my Figs. 1, 2, 3, and 6.

As to the third hypothesis, I wish to point out that it would link up one with the other the various findings as well as these with histo-pathological changes, which most authors consider extremely like those seen in cases of trypanosomiasis. Those who recollect the aspect of some of the small (internal) forms out of which the Negri bodies appear to result will recognize that between these and the "minute bodies" described in this paper there is a morphological and structural similarity which is at least striking. I quite realize that such a suggestion will acquire value only if other investigators are able to confirm my observations, and particularly if the apparent "bodies" can be found in the nervous or other tissues of animals to which the disease has been successfully transmitted.

SUMMARY.

In the nervous tissue from cases of epidemic (lethargic) encephalitis within and without the nerve cells minute forms have been observed, to all appearance consisting of a central generally basophil particle and of a delicate little stainable body, irregularly round or oval in shape. For these forms the term "minute bodies" is *pro tempore* proposed.

The bodies are generally discrete, and provided with one granule, but dumbbell shaped forms occur as well as others with two central particles arranged in pairs. An as yet not quite definable relation seems to exist between these forms and a granular, pigment-like material occurring within the nerve cells in places where brown or black pigment is not generally found.

Minute forms, similar in shape, structure, and staining properties to those observed in the nervous tissue, have been traced within and without the cells infiltrating a salivary gland from an acute case of the disease.

After discussing the supposition that such findings might be the product of an optical illusion, associated perhaps with degenerative changes caused by the malady, the suggestion is tentatively put forward that they may be due to the presence in the tissues of a living agent, cause of the disease.

REFERENCES.

A. Negri: Sulla Morfologia e sul ciclo dei parassita della rabbia. *Mem. R. Acc. Lincei*, Roma, 1903, vii (S. 59), 471.
 C. Da Fano and H. Ingleby: Demonstration of Preparations from Cases of Encephalitis Lethargica. *Proc. Roy. Soc. Med.*, 1919, xii (Sect. of Path.), 42.
 P. Marie and C. Trétiakoff: Anatomie pathologique de l'encéphalite léthargique. *Ann. d. Méd.*, 1920, vii, 1.

"HARLEQUIN FOETUS" (HYPERKERATOSIS CONGENITALIS).

BY

JAMES T. McAUSLIN, F.R.C.S.,

SENIOR RESIDENT SURGEON, ROYAL MATERNITY HOSPITAL, EDINBURGH.

(With Special Plate.)

THE comparative rarity of this condition appears to warrant the following case being reported; only one case has been recorded here in fifty years.

The mother of the foetus was a girl of 16 years, admitted in labour. On vaginal examination, a breech presentation could be made out, but it was obvious one was dealing with an unusual case. The os was well dilated and the skin of the foetal buttocks had the feel of "crocodile skin." One could not employ a more apt term to describe this, as the hard thickened skin was broken up into numerous irregular patches similar to that of crocodile hide.

The full-time foetus was born dead and weighed 7 lb. It presented a repulsive appearance, as the photographs show. The skin was dead white in colour, cornified and cracked in all directions, making the foetus appear as if clad in a horny armour. The distribution of these changes was universal. When a portion of the hardened skin was removed a red raw-looking area was exposed underneath.

The appearance of the eyes was interesting: no differentiation into the various parts, iris, pupil, etc., could be made out, the eyes appearing as two sacs filled with blood.

An examination was made by Dr. I. J. Browne (Assistant Physician, Ante-natal Department), who was unable to make out any definite morbid changes in the internal organs, except in the thymus, which, although of normal size, contained numerous small scattered abscesses throughout its substance. No spirochaetes could be demonstrated, but the appearance of the thymus was suggestive of syphilis. The microscopic sections were, I regret, not a success, owing to *post-mortem* changes. A Wassermann test in the mother, who made an uneventful recovery, yielded a negative result.

This condition has been confused with congenital ichthyosis, but "it is distinguished from it by the fact that it is present at birth, whereas ichthyosis appears towards the end of the first year of life; and by its distribution, which is universal, whereas ichthyosis is rarely very widespread at first, and hardly ever affects the palms and soles, which this disease always does" (Norman Walker).

I am indebted to Dr. Haig Ferguson for permission to publish this case.

ROTATION-DISLOCATION OF THE ASTRAGALUS.

BY

ROBERT OLLERENSHAW, M.D., F.R.C.S., ENG.

HONORARY SURGEON IN CHARGE OF ORTHOPAEDIC DEPARTMENT, SALFORD ROYAL HOSPITAL.

(With Special Plate.)

DISLOCATION of the astragalus alone is not a very common accident. The usual displacement is of the astragalus forwards—a condition which often results in a compound dislocation.

A more uncommon displacement is of the astragalus backwards, in which event it is to be felt lying between the tendo Achillis and the malleoli. Dislocation of the bone by rotation in its bed is rare, and when it does occur it is not possible to effect a reduction by manipulative measures. In this form of dislocation the astragalus is frequently detached from all its ligaments. Open operation is necessary, and removal of the astragalus has been the general procedure in the recorded cases. Stimson,¹ in his well-known book, describes dislocation by rotation of the astragalus and refers to seven cases. He insists that the description should only include those cases in which the astragalus has undergone rotation round a vertical or an antero-posterior axis, but still remains mainly within the tibio-fibular mortise. Barwell² reports a case in which he removed the astragalus and where good function was obtained. He recommends primary removal of the astragalus in all cases of rotation-dislocation in which "certain and sufficient, but not too persevering, attempts at reduction" have failed.

For this reason the present case, in which a rotation-dislocation with complete tearing of all ligaments was operated upon and completely reduced with an ultimate restoration of full function, appears to be a circumstance which it is essential to record in some detail.

W. W., male, aged 42 years, was working at the Manchester Ship Canal Docks on May 20th, 1920, and whilst walking with the right foot well advanced a heavy piece of timber fell from a height and struck the back of his left heel. He was admitted to the Orthopaedic Department of Salford Royal Hospital on the same day.

On examination there was an obvious dislocation of the astragalus, the upper articular surface being palpable below the skin on the outer aspect of the dorsum of the foot. There was also a fracture of the fibula two inches above the tip of the malleolus. A ray examination showed the nature of the dislocation to be a rotation of 90 degrees round the vertical axis (Figs. 1 and 2).

Manipulation was entirely unsuccessful, and operation was decided upon with the idea that astragalectomy would probably be required.

Operation.

A curved incision was made from a point one and a half inches above and behind the outer malleolus curving across the prominence of the astragalus to the mid line of the foot. The upper and outer surfaces of the astragalus were exposed lying immediately under the skin, and the tendo

of the peroneus tertius, almost completely frayed through. This tendon was found crossing the wound. This tendon was retracted inwards, and it was then found that the astragalus was completely free from all its attachments, the posterior surface pointing directly outwards and the head inwards. By forcing the foot into an exaggerated varus position and turning the bone it was possible to replace it so that it occupied its normal position. The foot was then everted, and the torn dorsal ligaments repaired and the peroneus tertius tendon sutured. The fibula fracture was positioned and the wound closed by interrupted sutures, and splinted on a metal shoe with a rectangular foot-piece.

Gentle effleurage was commenced a fortnight later with active flexion and extension of the ankle under supervision to ensure that no inversion of the foot should occur. In the intervals of treatment the foot was retained in the splint. At the end of this time (six weeks after operation) there was very useful movement. Weight bearing was not permitted until three months had elapsed from the date of the injury. Since that time the man has walked comfortably on the foot.

Fig. 3 shows the lateral view after reduction of the dislocation. Figs. 4 and 5 show the range of ankle movement. This case has been very instructive, particularly because it shows that removal of the completely detached astragalus is not essential, and that excellent function with no shortening—a result much superior to that obtained after astragalectomy—may be obtained by this more conservative method.

REFERENCES.

¹ Stimson, *A Treatise on Fractures and Dislocations*, 1908. ² Barwell, *Med.-Chir. Transactions*, vol. lxxvi.

ON THE PROBABLE IDENTITY OF RICKETTSIA PEDICULI WITH RICKETTSIA QUINTANA.

BY

A. BACOT, F.E.S.,

ENTOMOLOGIST TO THE LISTER INSTITUTE OF PREVENTIVE MEDICINE.

MUNK and da Rocha-Lima (1917)¹ and Brumpt (1918)² found rickettsia bodies in lice taken from "healthy persons"; the two former writers named this supposed distinct species found by them *Rickettsia pediculi*, although they stated that it was indistinguishable morphologically and in its distribution in the louse from *R. quintana*, which they found associated with lice that had fed on trench fever patients. They infer that there is a form of rickettsia, infecting the gut of lice, which has no relation to trench or typhus fever. If this is correct, the discovery of these organisms in the lumen of the gut has no necessary significance. My colleague, Dr. Arkwright, and myself have, however, examined numbers of lice taken from civilian clothing in London and have never seen rickettsia bodies except when the insects have fed upon patients who have suffered from trench fever, and it is accordingly conceivable that this disease may have existed unrecognized among the population from which Munk and da Rocha-Lima and Brumpt obtained their lice.

The following account of a case of trench fever occurring in a region where the disease was supposed to be non-existent, in which the rickettsia bodies appeared in lice shortly after the insects were fed upon the patient, is of interest in this respect.

In April, 1920, I experienced while in Warsaw a febrile attack which exhibited the clinical signs of trench fever. The clinical evidence was, moreover, supported by the development of rickettsia bodies in the lice which I took to Poland with me. All the details of the case were under the observation of Professor Wolbach of Harvard, and Professor J. L. Todd³ of McGill, who agreed (1920) that the symptoms were those of trench fever.

On February 18th I joined Professors Wolbach and Todd in Paris in the capacity of Entomologist to the Typhus Research Commission to Poland of the League of Red Cross Societies. I carried with me stocks of *Pediculus humanus (capitis and corporis)* which have been under observation and fed only upon myself since November, 1915. Lice from these stocks were used for experimental work in connexion with trench fever by Sundell and Nankivell, the War Office Trench Fever Committee, and the American Red Cross Trench Fever Committee. Since the com-

mencement of the use of these stocks for trench fever research (more than two years ago) lice from them have been frequently tested for the presence of rickettsia bodies, but the insects have remained free; and prior to my visit to Warsaw I had never experienced any febrile attack which displayed the clinical signs of this disease.

We arrived at Warsaw on February 25th, but owing to unavoidable delays were unable to commence laboratory work until the latter end of March, when, as a preliminary step to the use of our stocks of lice for typhus research, a series of control smears were made from the guts and excreta of lice taken from the boxes. Both the American and English stocks were found free of rickettsia bodies. Steps were next taken to obtain a supply of normal Polish lice for comparison. These we were able to obtain by the courtesy of the officials at one of the municipal bath houses where uncleanly and frequently verminous, but not sick, persons were sent for cleansing, their clothing being subjected to hot-air treatment while they bathed. We were informed that lice from this source would be free from suspicion with regard to typhus.

I searched underclothing for lice in this establishment on March 31st and obtained a small supply, larger numbers being forwarded to us a day or two later by the officials in charge of the bath house. The dissection and making of smear preparations of these Polish lice occupied a portion of my time daily up to April 5th, when the few remaining alive were killed and fixed for sectioning. Of course no attempt was made to feed them. Of 151 of these lice 11 (about 7 per cent.) were found to be infected with rickettsia bodies indistinguishable from *R. quintana*. In sections these were seen only in the lumen of the gut; with smears it is not possible to decide definitely whether the cells lining the gut are or are not infected.

History of Author's Illness.

On April 17th I experienced a sharp febrile attack. Feeling very unwell when I awoke at 6.30 a.m., I took my temperature and found it to be only 97° F., but by 2 p.m. it had risen to 101.7° F. I had a severe frontal headache, and by 9 p.m. my temperature was 103.6° F. I passed a restless night with broken slumber. On April 18th at 8 a.m. the temperature was 101.6° F., and at 10 a.m. 102.3° F., and arrangements were made for me to go to the American Red Cross hospital at Praga. When I arrived there at 3 p.m. my temperature was 101.4° F., at 6 p.m. 101.3°, and at 8 p.m. 101° F. That night I had but little sleep as I suffered from continuous pains in my bones and joints, from ankles to hips and wrists to elbows, accompanied by heavy sweating. These pains, though of low intensity, were, no doubt on account of their wide area of distribution, peculiarly discomforting. On April 19th my temperature remained at or below normal all day. I felt better, but was somewhat depressed and the sweating continued. At night the pains in my limbs were very acute and continued until about 2 a.m., when they gradually subsided and were replaced by a dull confused sensation in the head accompanied by visual hallucinations whenever I closed my eyes. I sweated heavily and got no sleep until after daybreak. I recognized shin pains as more intense than the general aching of my limbs on this occasion. On April 20th I was better in all respects but very weak. My temperature remained down, and at night the limb pains were slight and discontinuous; the shin pains were, however, more intense by comparison. I slept much better.

In view of the possibility of the attack being typhus (I had been dissecting typhus-infected lice twelve days previously), I refrained from feeding my large stocks of lice at the commencement of the attack, but recommenced to do so when my temperature fell to normal on April 19th as I was convinced that I had not suffered from typhus.

I was very much better on April 21st, and was told that I might leave the hospital on the morrow, but actually left the same afternoon at my own request, as I was very anxious to get back to my quarters in proximity to the laboratory. I suspected that the attack was trench fever and it was important, in order to settle this point, to keep my stocks of lice in the incubator, and make smears of the lice and their excreta from day to day.

That same night (April 21st) I had a renewal of the attack: temperature up to 101° F., with some increase in the intensity of the pains in limbs, but not sufficient to disturb my sleep. The shin pains were again more intense than those in the other bones, and with each recurrence this feature became more apparent. A noticeable feature in connexion with these pains was that, whereas in the primary attack they did not commence until the fever was subsiding and were still acute after it had left me, they now accompanied the febrile wave. Later they commenced prior to a rise in temperature however slight, and on at least one occasion they occurred without any perceptible rise in temperature. Following this renewal of the attack, my temperature rose each night and fell by day for about ten days, and subsequently slight rises occurred at about five-day intervals, some being barely perceptible. Weakness, lethargy and depression tended to increase as the febrile waves became less pronounced. Slight shivering, alternating with flushing and followed by sweating, frequently accompanied the slightest rise

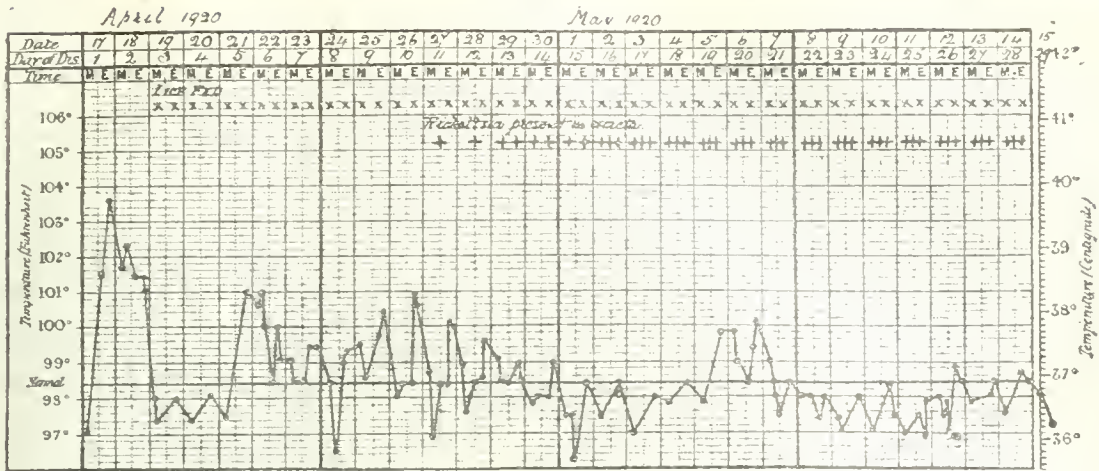

indicates opportunities afforded for the lice to feed. +, ++, +++ indicates the presence of rickettsia bodies in the excreta of the lice and the extent of the infection.

of temperature above normal. Shin and bone pains (chiefly in the knees) were often intense, sometimes accompanied by nausea and headache, causing restlessness and preventing sleep for a portion of the night.

These symptoms occurred for the last time on May 12th, and by May 15th I felt quite fit save for a certain amount of lassitude. This gradually subsided.

No signs of rickettsia bodies were visible in the smears made from the excreta of the lice in my boxes until the eighth day after I recommenced feeding them; then a smear of the excreta from the only box that I was able to keep warm, in the pocket of my pyjamas, until the incubator at the laboratory was available, showed a few rickettsia bodies in several of the fields examined. This box (a) was two days ahead of the remaining five boxes in the matter of incubation, though the chances of infection in all the boxes dated from the same time.

The details of incubation after the first infecting meal are as follows: Box (a), two days at an estimated temperature of 85 to 90° F. The other five boxes, except during feeding times, remained during this period at about 60° to 65° F. After this all the boxes were kept in an incubator except when the lice were being fed. The temperature of the incubator varied occasionally between the limits of 90° and 100° F., but usually it remained at 93° F. Smears of excreta from box (a) showed a quite convincing rickettsia infection on the ninth day, while on the tenth and eleventh days these bodies were present in great abundance in the excreta from box (a), and were present in small numbers in most of the smears made from the excreta out of the other boxes. From the twelfth day onwards all the boxes were heavily infected. Smears of guts dissected out of adult lice taken from the boxes showed about 60 per cent. of easily recognizable infections. Out of some fifty sectioned lice taken from the boxes the percentage showing a general infection of the gut was somewhat lower than in the case of the smears, but a prolonged examination of the apparent negative instances often revealed a slight local infection where folds in the gut wall are of most frequent occurrence.

In no case was any evidence of intracellular infection discovered although careful search was made for it. The gut walls, which seem to be so favourable a situation for the development of *Rickettsia quintana*, were, however, generally more or less lined with them, in some cases so uniformly as to give the appearance of palisading.

My blood remained infective for lice after all the symptoms had completely disappeared. Ova from my stocks were washed on May 17th for several minutes in 4 per cent. lysol and then in running tap water for thirty minutes, they were then dried, put into a clean box, and the lice after hatching were fed upon myself; excreta from this box showed the presence of rickettsia bodies on June 11th and 21st.

Ova from my boxes were washed in the same manner on June 11th and placed in two clean boxes to hatch, the lice in one of the boxes being fed by Dr. Arkwright and those in the other by myself. Smears made of the excreta from these boxes showed that the insects fed by Dr. Arkwright were free from rickettsia bodies on June 28th and July 5th, whereas those fed by myself gave positive results when

tested on June 28th, July 29th, and August 2nd and 6th. Lice were taken from Dr. Arkwright's box on July 20th, placed in a new box and fed upon myself; excreta from this box remained free from rickettsia bodies for ten days but showed them on the fourteenth and eighteenth days.

Ova of *Pediculus capitis* taken from one of my boxes on August 6th and washed in the manner already described were placed in a new box; the lice which hatched were fed on myself and the excreta from this box showed a slight infection with rickettsia bodies on September 8th, but subsequent tests of excreta from this box, and also from the one containing lice from Dr. Arkwright's stock, have shown no trace of rickettsia bodies up to mid-October. That is to say, lice fed upon my blood four months after an attack of the disease and three months after the disappearance of all symptoms developed the organisms in their guts, so that it would not seem improbable that the occurrence of rickettsia bodies in the lice from healthy persons was due to the lice having fed on a convalescent from trench fever.

CONCLUSIONS.

1. Trench fever patients may remain capable of infecting lice with *Rickettsia quintana* for at least three months after the cessation of febrile attacks or other obvious symptoms.
2. Persons in apparently good health may therefore infect lice with *Rickettsia quintana*.
3. Lice infected with rickettsia bodies indistinguishable from *R. quintana* were present in Warsaw in 1920, and were associated there with a case of trench fever.

REFERENCES.

¹ Munk, F., and da Rocha-Lima (1917): Klinik und Aetiologie des sogenannten Wolhynischen Fiebers (Werner Hissche Krankheit). II. Ergebniss der ätiologischen Untersuchung und deren Beziehungen zur Fleckfieberforschung. *Muech. med. Woch.* 1917, 30, s. p. 1422.
² Brumpt, E. (1918): "Au sujet d'un parasite (*Rickettsia prowazeki*) des poux de l'homme considéré à tort, comme l'agent causal du typhus exanthématique." *Bulletin de la Société de Pathologie Exotique*, xi, No. 3, p. 249.
³ Wolbach, S. B., Todd, J. L., and Ehrlich, P. W. (1920): A Preliminary Report from the Typhus Research Commission of the League of Red Cross Societies to Poland. *Internat. Journal of Public Health*, vol. i, No. 2, September, 1920.

RECENTLY the French Minister of War asked the Académie de Médecine several questions with regard to the best age and most suitable time of the year for calling young men to the colours. He asked whether it would be better to call them up at the age of 19, 20, or 21. The Académie, in its reply, while pointing out that growth in man does not cease until 25, stated that the age for incorporation in the army might be 20, but that the medical examination at that date should be very strict. The end of April was considered the best time for calling up the class of that year, but if a second call was necessary it was thought that it should be made during September. The best barracks available should be used for housing young soldiers, who should be supplied with a complete change of clothes, to be used when they come in tired and wet. The food, it was stated, should be abundant, varied, and prepared by trained cooks.

Memoranda:

MEDICAL, SURGICAL, OBSTETRICAL.

DENTROSE IN CARDIAC FAILURE.

EARLY in 1912 my attention was drawn to the fact that a 5 per cent. saline solution of glucose was of great benefit in post-operative shock; I was able fully to corroborate this in several cases of my own; when the patients showed marked signs of collapse following an abdominal operation, one pint of a glucose saline solution injected per rectum had the effect of tiding the patient over this critical period, and every one made a complete recovery.

On October 15th, 1920, I was called to see a gentleman, aged 70, who two years previously had contracted pneumonia, and a small unresolved patch at the base of the right lung had remained; I found that the patch had again become active; the pulse was 108, respirations 36, and the temperature 99.6° F.; he had a persistent irritating cough with mucous rales all over the right side, with all the signs of an active bronchopneumonia. For several days the pulse kept between 102 and 108, and intermittent; the respirations were shallow, with numerous moist rales all over the right lung, more particularly at the base; the left lung was comparatively free. He was sleepless owing to the cough.

On October 19th the base of the left lung became involved. The temperature was between 98.4° and 100° F., respirations 48, pulse 104, with marked intermittency. Cough was very troublesome and the patient was sleepless. He remained in this condition for the next few days, but showed signs of getting weaker, and on October 24th he required an injection of hypophysis 1 c.cm., as the pulse showed signs of failure. The temperature was now between 97.6° and 98° F., and respiration was hurried and shallow; the lungs showed no signs of improvement, while the heart laboured with marked arrhythmia. As his nights were the worst, and he was unable to lie down, he received an injection of hypophysis once or twice throughout the night.

About 3.30 a.m. on October 26th I was hurriedly sent for owing to his sudden collapse. The extremities were cold, the pulse almost imperceptible, heart sounds faint and very irregular; the temperature 95° F. With appropriate remedies he revived; oxygen was given. The temperature gradually rose until it reached 97.6° F., the pulse 92, small and intermittent; respirations 42.

On October 30th a 5 per cent. solution of dextrose was administered in teaspoonful doses every fifteen minutes. Throughout the night he suffered from wandering delirium, his speech was indistinct. The respirations would fade away, then become somewhat stertorous, only to die away again. After the continuous exhibition of the dextrose solution for thirty-six hours the respirations had become natural although still rapid, the temperature still subnormal, but the mental apathy completely gone. The heart was regular.

I now gave him hypophosphites with hydriodic acid and 5 drops of the digitalis; the chest began to clear. By November 12th the chest had almost entirely cleared up; the pulse was 72 and regular, and the heart sounds normal.

I have recorded this case in the hope that others will give dextrose a more extended trial in cases of cardiac failure. My experience previously had only been in operative work, and its success was so marked that the idea occurred to me that to give small doses continuously for a lengthened period would achieve the same effect as giving a rectal injection.

G. SCOTT MACGREGOR, M.D.,
Senior Surgeon Glasgow Hospital for Women.

TUBERCULOUS HAEMARTHROSIS OF THE KNEE.

So far as the writer is aware the condition here reported is a very rare one, only a few cases being on record.

The patient, a girl of 15, was admitted to Duke Street Hospital suffering from multiple tuberculous lesions. The glands of the neck were involved; she had tuberculous dactylitis, and there were small lesions in connexion with the epiphyses of the left wrist, right ankle, and right elbow. Wassermann reaction negative. No history nor evidence of haemophilia.

The patient was placed in bed with extension, on account of the condition of the right ankle-joint, which was swollen and tender; but she was allowed up when the condition of the ankle improved.

The right knee had been painful upon occasion from the time of admission, but the pain now became gradually worse and more constant, and, upon slight swelling of the knee-joint occurring, extension in bed was reapplied. The

extension relieved the pain, but it did not disappear entirely and the swelling became more marked, until about three weeks after return to bed the swelling rapidly became extreme, while the pain was severe.

An exploratory puncture was therefore made, and a large quantity of dark fluid blood, together with a few clots, was evacuated, after which the joint resumed its normal size. A firm bandage was applied and the patient felt greatly relieved. The improvement continued for about ten days, when the joint again became rapidly distended, and a further quantity of blood was evacuated. Horse serum was given to promote the coagulability of the blood, but a third bleeding occurred a week later and the blood was evacuated.

Thereafter there was no further haemorrhage and the patient's health steadily improved, but the joint remained slightly swollen and tender, and the synovial membrane distinctly pulpy.

JOHN A. C. MACEWEN,
Surgeon, Glasgow District Hospitals; Honorary Surgeon,
Erskine Hospital for the Limbless.

ABDOMINAL TUMOUR FOLLOWING INJURY TO THORAX.

PRE. X, a young man, was admitted to hospital in France labelled "N. Y. D. abdomen." He complained of intermittent pain and discomfort in the upper left abdomen, with occasional vomiting and weakness; these symptoms extended over some months. He gave no history then of any injury; none was suspected, nor was there any apparent evidence of such.

The patient did not look ill. Palpation of the abdomen showed marked resistance over the left hypochondriac region. He was given fluids and watched. The symptoms continued with slight occasional rises of temperature and slightly quickened pulse rate. No diagnosis was made, but possibilities were thought of—none in the right direction, however. A week after admission he was taken to the operating theatre. Abdominal palpation during induction of anaesthesia showed resistance markedly present until he was fully under, when a definite tumour, moving with respiration, could be made out in the uppermost part of the left upper quadrant. On laparotomy I found a large puckered ball of great omentum lightly adherent to the left half of the diaphragm, which was reddened. The omentum was easily unrolled and placed in its normal apron position. The wound being closed and sealed off with aeroplane varnish, a second vertical incision was made in a line external to the nipple, over the seventh and eighth costal cartilages. Pus was found and these cartilages were eroded. The cavity was scraped, flushed, and drained. Both wounds healed quickly and no abdominal symptoms recurred.

On being interrogated the patient subsequently stated that he had been kicked in the left lower chest some months previously. The case, therefore, seems to demonstrate excellently that the "abdominal policeman" was as usual unremitting in attention to duty—in addition to his own regular "beat," he was in readiness to deal promptly with an intruder from an outside source.

F. J. STRACHAN, M.C., M.B., B.S.
Dunreggan, Troon, Ayrshire.

GLANDULAR AND PULMONARY TUBERCULOSIS.

A VERY constant, if not invariable, fact I have observed in my fifty years' experience of tuberculosis is that those members of families with an inherited predisposition to the disease who suffer from cervical gland lesion leading to suppuration do not get pulmonary tuberculosis, or, indeed, any other form of the malady; whereas several other members of the same families without gland lesion, and often the more robust individuals, frequently develop consumption. All my cases have also shown signs that the apex of the corresponding lung had been affected but had recovered. Depression and dullness were present in some cases, but in all there was condensation, as shown by very marked increase of vocal resonance.

Can, then, the absorption of tubercle bacilli from the surface of the mouth when conveyed by the lymphatic vessels and arrested in the glands, as indicated by these glands breaking down, lead to the production there of a type of bacillus capable of curing consumption and of conferring immunity without the bacilli themselves going beyond the glands? That is, I think, what is to be inferred from the above account.

W. WILLIAMS, M.D., M.R.C.P.,
Consulting Physician, Royal Southern Hospital, Liverpool.

Reports of Societies.

TREATMENT OF INOPERABLE UTERINE CARCINOMA.

At a meeting of the Section of Obstetrics and Gynaecology of the Royal Society of Medicine, held on January 6th, with the President, Professor HENRY BRIGGS, in the chair, Mr. PERCIVAL P. COLE read a paper on a series of forty-three cases of inoperable uterine carcinoma treated by the cold cantery method of Percy. He felt impelled to make known his experience of this method, as it had been the subject of considerable criticism in America. Owing to this adverse criticism the method had not been supported in this country, and, although other cantery methods had been employed, the speaker was under the impression that his experience of this particular method was unique. He laid much stress on the value of unvarying assistance, and expressed his obligation to Mr. O. T. Dinnick, who had assisted him at most of the operations.

The technique of the operation could be divided into (1) abdominal—the abdominal cavity being freely opened by sub-umbilical incision, and the internal iliac arteries, the ovarian vessels, and the round ligaments ligated; (2) vaginal—dilatation of the vagina being first effected by means of a flange and screw dilator, until the insertion of a water-cooled speculum could be made. This speculum had a surrounding water-jacket space, through which water circulated and so protected the vaginal wall from damage by the heated cantery. Redundant growth was removed by a sharp curette and the cantery then directed through the cervix into the uterine cavity. From this time onwards the direction of movements of the cantery were controlled by the assistant, either by verbal directions or by movements, his hand inside the abdomen grasping the fundus of the uterus. Two degrees of heat had been employed—a high or destructive degree and a low or cooking degree; the degree of heat had to be estimated by the abdominal assistant, and might be considered by him sufficient when the heat transmitted through the tissues to his palpating hand was such as to be just bearable. When fundus and cervix had been treated, outlying areas in the bases of the broad ligaments were dealt with, particular stress being laid upon the care necessary to avoid overheating when dealing with the anterior vaginal wall. Failure in this respect had led to the formation of a vesico-vaginal fistula. It was freely admitted that this post-operative complication was most distressing to the patient, and was, in fact, the chief drawback of the procedure. When the pelvic contents had been efficiently treated the pre-operation rigidity had given place to a softness and mobility which were both unexpected and characteristic. Viewed from below the cervix presented a large funnel-shaped crater, the sides of which were quite firm, perfectly dry, and of a peculiar greyish-yellow colour. When the canterization had been completed the abdominal wall was sewn up in three layers by the assistant. In 1914 ligation of vessels was not undertaken by Dr. Percy, but the ligation of the iliaes, and other vessels to the uterus, was carried out by Mr. Cole on account of severe secondary haemorrhage, which the first few cases clearly showed to be a grave danger. Danger to the ureters had been found to be negligible in ligaturing the internal iliaes, a greater risk being that of wounding the iliac vein as it lay behind the artery.

Gauged by any standard of selection, the type of case dealt with in this series of forty-three was inoperable; the cases were recruited from inoperable cases so certified by practitioners, or admitted to the Cancer Hospital from the out-patient department, their condition being verified in every case by the visiting staff. The almost constant presence of pyometra, as revealed at operation, was commented on, and the extraordinary immediate improvement in the appearance of the patients could best be accounted for on the assumption that pyometra was the causative factor. The comparative rarity of demonstrable glandular invasion had been remarkable, and it was suggested that this freedom was not only apparent but real, for Leitch, in a series of 915 *post-mortem* examinations, had found that metastasis of any kind occurred in only 405, or 45 per cent. In other words, 55 per cent. of cases which had run their course without surgical intervention had died as the result of effects determined by what had remained to the last a local lesion. Dilatation of the ureters—sometimes to an extreme degree—had been frequently noted; and, again, it was pointed out that Leitch in his series of 915 cases had found the kidneys hydronephrotic and the ureters dilated in 75 per cent.

As regards the progress of these cases, the abdominal wall had healed without suppuration in every case. Temperature and shock had been absent, and an immediate improvement in the patient's appearance had been

consistently noted, yet several of the patients were over 50, and one was aged 68. A foul discharge might commence on the third or fourth day and exist for a fortnight or so; this was best treated by the administration of a weak iodine douche. Patients had been kept in bed for three weeks, and had left the hospital at the end of a month. Vesico-vaginal fistula had resulted in seven cases; in those cases leakage might have diminished somewhat, but healing had never taken place. This most uncomfortable complication was, however, a frequent result of the untreated disease, and it was urged that vesico-vaginal fistula with freedom from malignant disease was, at any rate, preferable to a vesico-vaginal or recto-vaginal fistula with all the accompaniments of progressive and septic cancerous infiltration. Mr. Cole had no desire to conceal the fact that failures had been frequent, but as the cases dealt with by him could not conceivably be made worse, any improvement was to the good. He exhibited three cases:

(1) A young woman, now aged 35, upon whom operation had been performed nearly three years ago, and examination by members of the Section had failed to reveal the existence now of any demonstrable malignant disease. (2) A woman aged 45, operated on one year ago, was free from discharge and pain since the operation and was now enjoying good health. (3) A woman, now aged 71, operated on three years and three months ago, had a vesico-vaginal fistula, and, although she found the fistula a source of great discomfort, she was yet quite emphatic that life was worth living; she also was recorded as now being free from demonstrable malignant disease.

It had been found latterly that the following up of these cases by the implantation of radium needles had given good results, and Mr. Cole was of opinion that this conjoint treatment by cantery and radium held out to these patients the best chance of palliation and temporary relief from distressing discharges, together with a chance of a very materially increased term of useful life.

Morphine in Labour.

Dr. LOUISE McILROY read a short communication on the use of morphine in labour, based upon the results of the administration of morphine in obstetrical cases occurring in the officers' wives' section of the 82nd General Hospital, Constantinople. A large number of civilian patients were also admitted for treatment, including Turkish, Greek, and Russian women. The majority of the patients were primiparae, and the cases were not selected, but morphine was given in complicated cases, such as malpresentations, albuminuria. No vaginal examinations were made, except in cases where complications were suspected. No douching of the vagina was carried out. Morphine was given in the form of tablets of morphine sulphate hypodermically in the upper arm. The initial dose was $\frac{1}{2}$ grain, and repeated doses of from $\frac{1}{4}$ to $\frac{1}{2}$ grain were given at varying intervals throughout labour, according to the condition of each patient and her capacity for bearing pain. There was no excitement observed nor mental confusion; the patients slept at intervals and awakened refreshed. The uterine contractions only showed apparent or temporary diminution, and the progress of the labour was found to be hurried rather than delayed. After some experience of the effect of the drug, it was given, not with the primary object of allaying pain, but of shortening labour. Thirst was increased, restlessness was diminished, the third stage was unaffected, and no risks were apparent with regard to the child. No *post-partum* haemorrhage was observed; less fatigue and absence of shock caused a favourable convalescence after labour. The constant attendance of the medical practitioner was not required, as in the administration of scopolamine-morphine. The results were satisfactory and gave this drug a useful place in the management of labour.

Dr. HERBERT WILLIAMSON did not agree with Dr. McIlroy as to the absence of effect on the child; in his experience, if the drug were given within two or three hours before the birth of the child, the latter was born in the condition known as oligopnoea. If left alone, the child generally came round all right.

Dr. HERBERT SPENCER said that in his opinion and in the opinion of many obstetricians before his time, opium, in solid or liquid form, was a much better sedative in labour than morphine. He felt sure that morphine endangered the child's life when given repeatedly up to shortly before its birth. It could not be too strongly

insisted upon that the repeated administration of powerful drugs as a routine measure was neither necessary nor advisable in ordinary healthy women.

Dr. AMAND ROUIN asked how was the shortening of the first stage caused. Was it by the lessening of the rigidity of the cervical muscle as after chloral? Apparently in the second stage there was some muscular relaxation of the pelvic voluntary muscles, and some lessening of the abdominal reflex contractions, but further observations were essential.

Dr. LAPHORN SMITH said that in all cases of primiparæ it was his practice to prescribe a mixture with 30 grains of sodium bromide and $\frac{1}{2}$ grain of morphine to the dose, to be given as soon as labour began and repeated four-hourly. Nurses had called his attention to the excellent condition of patients after labour in these cases. He repeated the morphine by hypodermic injection when required.

PELVIMETRY IN CONTRACTED PELVIS.

At a meeting of the Edinburgh Obstetrical Society held on January 12th, with Dr. HAIG FERGUSON in the chair, a paper was read by Dr. DAVID SHANNON, Glasgow, on pelvimetry as an index of treatment in contracted pelvis. His observations were limited mainly to pelvis deformed at the superior strait, and the motive of his paper was to endeavour to prove that, except in a few cases, the measurement of any diameter at the pelvis could not be used alone to indicate treatment and to bring forward a method of pelvimetry which could be used as an index of treatment in all cases. The normal minimum of the pelvis had been laid down by Michaelis and Litzmann, but judging from textbooks, in which such a marked variance existed regarding pelvic measurements, their standard had not been accepted, with the result that it was difficult for a practitioner to say when a pelvis was really contracted, and certainly he could not base treatment upon such measurements with confidence. It was very difficult to measure a pelvis accurately, and the deductions in many cases from such measurements could not be trusted sufficiently to guide one as to the best treatment to adopt.

Dr. Shannon illustrated his contentions by referring to a series of 316 cases of contracted pelvis, in which he outlined the treatment carried out. The pelvis were grouped in such a way that the conjugates of the superior strait measured the same in each group. For example, in that group in which the conjugata vera measured $3\frac{1}{2}$ in., 34 per cent. were born spontaneously, but amongst the other cases almost every obstetrical operation was performed. Pelvic measurement, he stated, could be used as an index of treatment, provided the foetal head did not vary in size and consistence, but as it did so often vary it was essential to estimate its size relative to the brim of the maternal pelvis in each case before treatment could be decided upon. On that account, therefore, the foetal head was the best pelvimeter. This fact was appreciated by many obstetricians, notably Müller, Pinard, and Munro Kerr, each of whom had given us a method of determining this important factor. Munro Kerr's method was a distinct improvement on the others, and, with a little practice, could be used as an excellent index of treatment in these difficult cases. This method of estimating the relative size of foetal head and pelvic brim Dr. Shannon proceeded to describe in some detail.

In pressing the foetal head on to the superior strait of the pelvis it was advised to imitate Nature. In pelvis of the flat variety downward pressure should be made, so that the sagittal suture lay in the transverse diameter of the pelvic brim. In most cases this was easy, but in some—those in which the occiput was posterior—it was noticed that the head often lay in the oblique diameter, and, in such cases, it had to be changed into the transverse before pressure downwards was made, if the best results were to be obtained. In generally contracted pelvis, also, the head did not always lie well placed and in an oblique diameter, and so, in pressing it downwards, care had to be exercised so that the head entered the oblique Nature intended it to enter. These abnormal positions of the head were first noted by palpation and verified later whilst performing Caesarean section by the lower uterine segment incision. If the foetal head was pushed down on to the superior strait carelessly there was a possibility that a certain amount of lateral flexion of the head might take place, with the result that the amount of overlapping of the head over the symphysis pubis would be more apparent than real. It was to be noted that the thumb, by which the amount of overlapping at the symphysis pubis was estimated, was the principal part of Kerr's method,

and differentiated it entirely from the methods of Müller and Pinard. The thumb should be laid flat on the outside of the symphysis and flush with its upper border. A full bladder and a pendulous abdomen, especially in primiparæ, made the estimation of overlapping difficult. A loaded rectum, tumours, or a placenta lying behind the foetal head pushed the head forwards so that the overlapping was exaggerated. Occipito-posterior cases in generally contracted pelvis overlapped more than those in which the occiput was anterior. The maximum amount of overlapping was not palpated at the centre of the symphysis but to one or other side. In flat pelvis the greatest amount of overlapping was noted just immediately above the upper margin of the symphysis pubis, but in generally contracted pelvis the thumb had to travel above this point to arrive at the seat of greatest disproportion. This was specially true in occipito-posterior cases.

It was as an index of treatment that Kerr's method was of such value, and Dr. Shannon detailed the procedure as carried out by him in his own wards, dividing contracted pelvis, with a view to treatment, into four groups, according to the amount of overlapping of the foetal head at the symphysis pubis.

Group A.—The foetal head, on pressure, sinks into the pelvis. There is no overlapping, although the pelvis is contracted. With a patient in labour such a case is treated as normal and a spontaneous termination expected. If not in labour, she is requested to return for examination at a later date.

Group B.—This comprises cases in which overlapping is of minor degree. The head does not enter the brim. It "bites." Measured by the thumb, the overlapping is not flush with the outside edge of the symphysis pubis. If those cases are in labour, they should be left to Nature. The forces of labour will obliterate the disproportion and a spontaneous birth can be expected. If not in labour, this is the best time to induce it prematurely, provided the child has reached the thirty-sixth week of intrauterine life.

Group C.—In this group there is a medium amount of overlapping. The thumb informs one that the head is flush with, and in some cases overlaps to a slight degree, the outside edge of the symphysis pubis. In those cases one hopes for a spontaneous birth. With that object in view patients are allowed to go on in the second stage for four, six, eight, or twelve hours. During this time the condition of mother and child must be carefully observed. Forceps are applied when the indications for the operation arise, and, should they fail to deliver, pubiotomy is resorted to.

Group D.—The foetal head bulges over the symphysis pubis so much that the overlapping can be seen in many cases, and often the disproportion is so great that the top of the thumb, as it lies in position, is partly covered by the part of the head that overlaps. In such circumstances one infers that no amount of moulding can diminish the diameter sufficiently to allow the head to come through the contracted brim, so one has no choice but to perform Caesarean section, if the child is alive, and craniotomy, if the child be dead.

Dr. Shannon referred to the difficulty of treatment in these cases, and laid stress on the fact that, before treatment could be efficiently indicated by Kerr's method, the following factors had to be carefully determined and their relationship one to the other accurately considered as far as was possible:

1. Pelvic measurements, to determine type of pelvis.
2. Consistence of foetal head.
3. The variety of biparietal obliquity.
4. The position of foetal head in pelvis.
5. The expulsive forces of labour.

Dr. J. W. BALLANTYNE thought Dr. Shannon's paper might be termed the scientific specialization of Barbour's dictum that the foetal head was the best pelvimeter. Dr. Shannon had said nothing about the cephalometer, and he concluded that Dr. Shannon's experience agreed with his own, that the results were fallacious.

Dr. LACKIE agreed that the usual estimation of the size of the pelvis from measurement was unsatisfactory in affording a guide to treatment in many cases, especially in the medium variety of contractions.

Dr. HAIG FERGUSON pointed out that the early descent of the head into the pelvis, which commonly occurred in a primipara before labour, explained why a second labour, in which the head had developed till full time above the brim, might be attended with greater difficulty.

Double Congenital Hydronephrosis.

Drs. R. W. JOHNSTONE and F. J. BROWN after reading a paper on a case of double congenital hydronephrosis. The child, a female infant weighing 6½ lb., appeared normal, but died without any apparent cause six hours after birth.

At the *post-mortem* examination the histological appearances of lung and liver suggested syphilis, but the father's Wassermann reaction was negative, and sections of the foetal organs

stained by Levaditi failed to show spirochaetes. The right side of the abdomen was occupied by a cyst the size of a cricket ball and connected with the right kidney. The left kidney seemed normal, but only about half the usual size. Microscopically the kidney showed a marked increase of the interstitial connective tissue with few tubules, those that were left being dilated, in some cases to form small cysts. The right ureter was thickened by new fibrous tissue, the muscle being diminished in amount. The left ureter was completely obliterated during part of its course by fibrous tissue.

The condition seemed to be primary in the ureters, and due to a chronic inflammatory change involving chiefly the muscular coat, and causing stenosis and obliteration of the lumen with secondary changes in the kidneys.

At a general meeting of the Camberwell Division of the British Medical Association, held on January 5th, at the Camberwell Infirmary, with Dr. A. F. HEALD in the chair, in the course of an address on "One or two points of medical utility," Dr. HERBERT FRENCH stated that in cases of so-called primary acute nephritis some focus of infection could generally be found somewhere in the body, and expressed the opinion that in many cases the tonsils were at fault; he quoted interesting cases in support of his theory. Dr. LLOYD referred to the occurrence of albuminuria in many cases of impetigo in children, and other speakers drew attention to pyorrhoea, and especially scarlet fever, as similar causes of nephritis. Dr. FRENCH also spoke of the good effect simple puncture had in many cases of delayed resolution in pneumonia, even in cases in which no fluid was obtained, but could offer no explanation of this phenomenon. Lastly, he referred to the good effect that could often be obtained by the administration of small doses of thyroid extract in the periodic sick headaches of women.

A PATHOLOGICAL MEETING of the West London Medico-Chirurgical Society was held on January 7th at the West London Hospital, with Dr. F. J. McCANN, the President, in the chair. A series of interesting pathological specimens was shown by Mr. W. McADAM ECCLES, Dr. W. H. WILLCOX, and other members.

Reviews.

THE PREVENTION OF VENEREAL DISEASE.

THE book, *Prevention of Venereal Disease*,¹ by Sir ARCHDALL REID, is addressed, on the one hand, to those who would prevent venereal disease in themselves, and on the other, to those who would prevent it in the community; it is endorsed by the Society for the Prevention of Venereal Disease, and contains the evidence and arguments on which that Society bases its policy. It has a preface by the author, and an introductory chapter by Sir Bryan Donkin.

That part of the book which deals with the means for preventing venereal disease by means of prompt disinfection is built on the foundation of some extraordinarily good results obtained by the author during the war amongst soldiers in the Portsmouth area and by Surgeon Commander Boyden amongst sailors at Whale Island. The figures as given are as follows:

Sir A. Reid: Average number of troops 2,000. Rate per 1,000 per annum, 1.5. Six cases of gonorrhoea and one of syphilis. Of these men, two infected by their wives, two (drunks) took no precautions, one only just arrived in camp not instructed and took no precautions, and two did not use disinfectant till more than one hour after risk run.

Surgeon Commander Boyden: 496 men used disinfectants. One case of syphilis: he used it six hours after exposure.

These figures will be accepted by anyone who has any knowledge of the subject. There is only one weak spot in them, and that is that he was dealing with a very shifting and migratory population. It is not possible for him to say how many men may have become infected before leaving his medical charge in whom the disease developed elsewhere, but for practical purposes this objection may be regarded as negligible.

That part of the book which deals with Sir Archdall Reid's method of early disinfection might well have been

compressed into a couple of pages, because, boiled down, it simply means that every person should have the knowledge that infection can be prevented by the immediate use of 1 in 1,000 solution of potassium permanganate, which, with a swab of cotton-wool for application, should always be carried on the person in a properly shaped and corked bottle for use as required.

But there is a good deal more than this in the book. The urgency of the problem is insisted upon, and here certain exaggerations, which are doubtless to be attributed to the enthusiasm of the writer, become at once apparent. He states, for example, that the prime cause of the German success in the spring of 1918 was the large number of British and Allied soldiers incapacitated in venereal disease hospitals! He states that almost every other person in the United Kingdom has, at some time or other, been infected with venereal disease, and that there are few, if any, families of which some members have not been infected. It is certain that numbers of practitioners with a great experience of practice, spread over many years, will demur to this. The problem is urgent enough, and there is no need to accentuate its gravity by even the slightest exaggeration.

A great part of the book consists of an interesting and well written dissertation on instinct and reason, inclination and morality, and a chapter on microbial diseases written so that it can be easily "understood of the people." The remainder of the work contains various statistics of disease in the overseas troops, with some pages on the findings of the Interdepartmental Committee and a verbatim report of the debate in the House of Lords on the motion for papers by Lord Willoughby de Broke. A great part of this section consists of controversial and polemical matter. Sir Archdall Reid has two King Charles's heads, the one "The Royal Commission on Venereal Disease," the other "The National Council for Combating Venereal Diseases." His condemnation of the Royal Commission, its composition and its report, and his imputation of unworthy motives on the part of its members which led to the issue of the report in the form in which it appeared, are exceedingly strong and intemperate. His particular objection is that the Commission took no evidence on Metchnikoff's discovery that the prompt use of calomel ointment after inoculation with syphilis in the case of apes prevented the development of the disease, and in its report ignored it. By not taking this evidence he states that the Commission betrayed its honour, did not play the game, and committed the offence which Englishmen hold unpardonable. The infection of soldiers, innocent women and children, and men, who were being poisoned by the many millions, was thrown into the scales, and against all this and against their own personal honour "the little members of this miserable little Commission put their most miserable little prejudices and found their prejudices the heavier." I have it from members of the Commission that no one ever suggested bringing the question of Metchnikoff's discovery before it. I am assured that had there been such a suggestion fullest inquiry would have been made and evidence courted. Sir A. Reid states that some of the medical members consulted whether they should introduce this subject, but abandoned the idea fearing prejudice and opposition. Therefore, the whole of the blame which he imputes to the Commission must rest on the heads of those medical members of it who, after consultation, decided not to bring a matter of such importance before it, and not on the unfortunate lay, clerical and female members, who, at that time, 1913-14, had probably never even heard the name of Metchnikoff or read of his discoveries. Such imputations on persons of the character of those who formed the Royal Commission are quite unjustifiable.

His second *bête noire* is the National Council for Combating Venereal Diseases. Because it does not see eye to eye with him it can do nothing right, yet he expends many pages in laying stress on the necessity for enlightenment of the public and the education of the very young in chastity and self-restraint, thus creating a "bias" in this direction, apparently quite obvious, or ignorant, of the fact that this is the main plank in the platform of the Council, and has been preached both at public meetings and in private whenever possible on hundreds of occasions during the last five years. He states that ablution rooms were instituted by the Army Council despite the opposition of the National Council. As a matter of fact that body, through one of its Vice Presidents, Sir Thomas Barlow,

¹ *Prevention of Venereal Disease.* By Sir G. Archdall Reid, K.B.E., M.B., C.M., F.R.S.E. London: W. Heinemann (Medical Books), Ltd. 1920. (Cr. 8vo., pp. 465. 15s. net.)

urged and helped in every possible way the establishment of these rooms throughout the army. Sir Archdall Reid considers that it possesses all the faults usual to scientific societies and teaching bodies which are under ecclesiastical control. As a matter of fact, on its medical and executive committees there are about thirty-eight medical members, one bishop, and one other minister of religion—the Rev. J. Scott-Lidgett.

Sir Archdall Reid has not much belief in the efficacy of lectures in preventing the men running the risk of infection. He does not seem to have heard any lectures, and the one reported to him by his orderly (if the report be correct) was well calculated to make the judicious grieve. He states that, as far as he knows, no impression was made and the men looked on it as part of their ordinary work. The results of one lecture given to 3,000 young troops, as testified by the medical officer in charge, were even better than those obtained by Sir A. Reid by disinfection. Before that lecture the incidence of venereal disease was about the usual in that unit; after it, during three months in a country district, and five months later on in an East Coast town, swarming with temptations, there was only one case of venereal disease and that was caught three days before the lecture. Figures very nearly approaching this good result have been given to the reviewer by commanding and medical officers of the various dépôts where lectures were given at frequent intervals during the war. Their testimony is that the result of a lecture was that the men who were sick came for treatment, and afterwards, while that unit remained at the dépôt, the number of cases of venereal disease diminished from 50, 40, 30, as the case might be, to 3, 2, 1, or none.

But it is barren work to revive past controversies with regard to the forces. The army has melted into the civil population, and doubtless some of the 40,000 men who came under Sir A. Reid's instruction will remember and carry out his methods in civil life; doubtless a certain number of the 500,000 men (slightly less or more) to whom I have lectured will retain the impression which these lectures (*malgré* Sir Archdall Reid) made on them, but the problem at the present time is that of the civil population as a whole, not that portion which constituted the naval and military forces during the war.

The policy of the Society for the Prevention of Venereal Disease is, shortly, that all persons should be instructed in the fact that disinfection at the earliest possible moment after a risk has been incurred will almost certainly ensure immunity from infection. This means, since the first risk taken may be as fatal with regard to contracting disease as the fiftieth, that young persons should be instructed as early in life as may be possible. As most of the risks run are the result of an unpremeditated impulse or temptation they must learn that it is essential that the materials for such disinfection should be carried about continually on the person ready for use. Miss Ettie Rout, a member of the Grand Committee of the Society for the Prevention of Venereal Disease, crystallizes the policy of that society in the following words, quoted by the Archbishop of Canterbury in the debate in the House of Lords: "Every boy and girl in our parishes must be provided free with the outfit which will make them secure, and when you have done that all will be right—go with clean people and you will be clean."

The success obtained by Sir Archdall Reid was due to the fact that he is an extremely able, enthusiastic and energetic man. In the book he describes how he gave instructions personally to every man on joining his unit—if only one man paraded as a new-comer, that one man was individually addressed and instructed. In all cases where the method of rapid disinfection failed, the failure is attributed to the fact that the troops—Overseas or British—were not properly and thoroughly instructed. To deal with the civil population of more than 40 millions not under discipline in this manner is impossible. To ensure that each individual is thoroughly and personally instructed in the methods of disinfection by a medical practitioner as competent, skilled and energetic as Sir Archdall Reid is not practicable. To expect that young men, and young women also, will learn the technique of disinfection from leaflets, posters displayed in a public place, or printed instructions in a "packet," and proceed to carry it out satisfactorily is absurd. The result could only be to multiply enormously the number of risks which would be taken by persons who

would imagine that if disinfected they were absolutely safeguarded. To carry about a bottle and swab of cotton-wool in the pocket would be a continuous suggestion and incentive to their use; and, as in many cases they would not be used properly, there would be a very much larger number of cases of failure than would occur if each individual were properly instructed by an expert. In addition, it must be remembered that the average individual would be apt to imagine that that which may prevent can certainly cure, and would use a disinfectant to treat the disease when developed—a result which would be disastrous to the individual and to the community.

Instruction is the keynote of the whole of the book, and it is pointed out that unless the instruction be efficient the results must be bad. Doubtless this book will have its uses—it will fortify with knowledge that man who, in a cold-blooded fashion, gratifies his passions; it will confirm him in the pursuit of his hobby, and in many cases will prevent the infection which might follow.

Should it be extensively read among the populace it will, in my opinion, give the first push on the downward road of promiscuous sexual indulgence to numberless boys and girls. Boys, because they will take it that such a publication gives official, or semi-official, sanction to loose conduct, and therefore, under the shield of disinfection, will take the line of least resistance. Girls, because in their case, in addition to the promptings of passion, there will be added the allurements of probable "contraception" and possible disinfection. Of these thousands many, no doubt, will be protected, but in a large number of cases prevention will fail. Many a pitcher, rendered bold by immunity, will go too often to the well. A soldier in Cologne said to the reviewer: "I swabbed it off six times and thought I had the seventh, but I have just come out of 25 General." The probabilities are, therefore, that under such teaching the gross number of cases of disease will be increased though the percentage rate may be diminished. A warning that an indiscretion may be followed by disease will most certainly diminish the number of risks taken.

It is a pity that, in a controversial work of this sort, the author should be intemperate in his language and ready to impute unworthy motives to those who are just as anxious to diminish the incidence of this disease as he is.

E. B. TURNER.

PSYCHOLOGY OF THE SPECIAL SENSES.

In the introduction to the reprint of his Croonian lectures on the Psychology of the Special Senses² Dr. Hurst says that his views on hysteria differ from those held by the majority of neurologists, but we cannot find that he gives an explicit account of what his views really are. We are disposed to infer, however, that they do not differ in any marked degree from those of Babinski, and that Dr. Hurst is in agreement with the majority of neurologists of experience. Like Babinski, he gives no answer to the fundamental question as to why among the many exposed to almost identical experiences in war and peace only a small minority should develop symptoms of hysteria. It is the answer to this question that we seek in vain equally among the writings of those who support the analytic method of investigation and those who, like Dr. Hurst, approach the problem of hysteria from an objective standpoint.

In conjunction with Mr. Gainsborough, the author studied the manifestations spontaneously presented by a number of healthy students, ignorant of medicine, who were instructed to pretend that they were suffering from paralysis due to an accident. The distribution of the mimic anaesthesia in these cases lends support to Babinski's dictum that between hysteria and fraud there is only a moral difference. So much is obvious, but it is not so clear why an absolute anaesthesia should never be found in the malingering which will enable him to bear, without flinching, a severe painful stimulus, whilst such absolute anaesthesia is not uncommon in hysteria. Few clinical observers will, we fancy, endorse the experience of Dr. Hurst when he says he has never been able to find any evidence of cutaneous hyperaesthesia in "Heald's areas" in cases of gastric or duodenal ulcer when he has guarded against suggestion. Emphasis is laid on the absence of

² *The Psychology of the Special Senses*. By A. P. Hurst, M.A., M.D. Oxon., F.R.C.P. London: H. Prowse and Hodder and Stoughton, 1920. (Demy 8vo, pp. 133; 29 figures. 12s. 6d. net.)

pharyngeal anesthesia as a stigma of hysteria, and it may be recalled that Iwanoff, in 1910, by observations on a large number of cases of hysteria, definitely disproved its existence.

A large section of the book is devoted to the subject of hysterical deafness. Here the author states that "the only test upon which complete reliance can be placed in the diagnosis of absolute hysterical deafness from absolute organic deafness is the presence of normal vestibular reactions in the former and their absence in the latter." But James, in 1882, found signs of vestibular reaction in 45 per cent. of deaf-mutes; Kreidl and, later, Golla found that about 50 per cent. of deaf-mutes gave a vestibular reaction; and Myding found an intact labyrinth in 50 per cent. of his *post-mortem* examinations of deaf-mutes. The suppression in hysterical deafness of the "jump," or auditory-motor reflex, the site of which has been shown by Sherrington to lie in the mid-brain, is evidence of an active cortical inhibition that is suggestive of much in the pathology of hysteria rather than of "unswitching of the synapses at the level of the reflex or still lower."

It is clear that we are still a long way from any general agreement as to the nature of hysteria.

OPERATIVE GYNAECOLOGY.

ONE of the most interesting features of the second edition of Dr. Crossen's *Operative Gynaecology*³ is his classification of the more important operations that have been devised for the treatment of prolapsus uteri. Not that he discusses or even mentions them *all*, but he classifies some hundred and ten of the more important modifications. This piece of work will be of value in enabling the less experienced operator, as the author hopes, to select the best operation in each individual case, and not to cleave to any one operation as if it could possibly be the best procedure in every case. The living pathology of prolapse differs so much in different cases that the prevalent tendency to do one operation, and one operation only, in the treatment of the condition cannot possibly lead to the best results.

The ordinary major and minor operations are well described, and many points, small but important, are brought out—points too apt to be overlooked in the pressure of routine work. The section on radical abdominal hysterectomy for cancer of the cervix is particularly full, and is illustrated in detail most helpfully, both as regards the various steps of the operation itself and the ureteral and other complications that may be encountered.

Dr. Crossen's book will be useful to gynaecologists and to surgeons embarking upon pelvic work. Its illustrations are very numerous and for the most part very helpful. There is, however, a lack of balance in the work, and it is extravagant to devote four pages to and to illustrate fully the operative treatment of such an exceedingly rare condition as syphilitic destruction of the urethra. Also it seems unwise and pathologically unsound, in the present state of our knowledge of it, to describe as a separate entity such a condition as acute pelvic oedema, of which only some five cases have been described. The author's textbook of gynaecology would be a more suitable place for the latter than an operative textbook. Apart from these slight weaknesses, however, it is a useful work, and both the author and the publishers are to be congratulated on a highly creditable volume.

PUBLIC HEALTH AND INSURANCE.

THE publication in book form of a number of *Addresses on Public Health and Insurance*,⁴ given by Sir ARTHUR NEWSHOLME in America, will be welcomed as giving the experience and opinions of one who was for eleven years the Chief Medical Officer of the Local Government Board. A considerable part of the addresses consists of a historical survey of the activities of the public health authorities of Great Britain, for which some remarkable successes are claimed. We are told, for example, that "between 1871-80 and 1910-12 in England the average expectation of life at birth for males increased from 41.4 to 51.5 years and for

females from 44.6 to 55.4, an increase within three or four decades of ten or eleven years in the average duration of life," which is equivalent to "an annual saving of 234,955 lives." Quite justifiably it is claimed that a large proportion of this improvement is due to the preventive measures carried out by public health authorities.

Sir Arthur Newsholme complains that the work of the health authorities has been hindered by the rigid boundaries within which their activities have been confined. "It was one of the misfortunes," he says, "associated with the deterrent policy of Poor Law administration in medical relief that separation between Poor Law and public health appeared to offer the best prospect of sanitary progress." The Report of the Poor Law Commission in 1909 fully recognized this fundamental mistake, and Sir Arthur repeatedly expresses his regret that action on the lines of the report was not taken. He thinks that "it would not have been an insuperable task to find a common measure of agreement between the majority and minority reports"; he contends that if the duties of Poor Law authorities had been transferred to the councils of counties and county boroughs, these authorities would have had a medical service of some 4,000 doctors with large infirmaries, and England would by this time have built up a national medical service freed from Poor Law shackles, and with a range easily capable of extension as needed. The national insurance system was adopted instead, and this he regards as a great calamity, which has delayed public health reform. In entering into this area of controversy it may be doubted if he does himself justice. He claims, but by no means proves, that the creation of the Insurance Committees, instead of handing over all medical functions to the public health authorities, was "one of the greatest blunders of the National Insurance Act." If the public health authorities and the Local Government Board itself had been far more perfect than they were, even in their limited domain, there might have been some ground for the claim, but it was not without the soundest reasons that on several occasions deputations from the British Medical Association strongly opposed the handing over of the medical functions to the Local Government Board. For many years the British Medical Association had agitated for a radical reform of the Local Government Board, but seemed powerless against bureaucratic influences; it was a blow to the bureaucracy of the Local Government Board when the National Insurance Act introduced for domiciliary treatment the totally separate *ad hoc* Insurance Committees.

It is somewhat surprising to find the author repeatedly saying that "the money in maternity benefit is given unconditionally" (pp. 95 and 111), for the Insurance Acts distinctly provide that maternity benefit "shall be administered in the interests of the mother and child in cash or otherwise"; the money gift is not unconditional. The model rules of approved societies make it clear that a mother must be attended at her confinement by either a doctor or a certified midwife, and a husband receiving maternity benefit is bound under penalty of imprisonment to make adequate provision to the best of his power for the maintenance and care of his wife during her confinement and for four weeks after her delivery. In addition to this, in numerous cases the societies have entered into agreements with suitable hospitals for in-patient treatment when required, thus administering part of the benefit "otherwise than in cash." Mistakes of this sort seriously detract from the value of the book. Nor does the author gain anything by belittling the work of the panel doctors, who have treated not only serious and chronic cases of disease best suited for home treatment, which no hospital would accept, but also enormous numbers of cases of incipient diseases where simple remedies and a few words of advice must often have prevented serious consequences. It is true, as the author says, that the national insurance scheme is restricted both as to the persons eligible and the range of treatment; Mr. Lloyd George claimed that the insurance scheme was a business proposition intended primarily for those who either could not or would not make provision against illness, and who could not or would not even pay their doctors' bills. As a business proposition the benefits and the range of medical services provided were strictly limited by the subscriptions, helped by a parliamentary subsidy from the State, and as a business proposition the insurance was able to weather the storm of the Great War when the local health authorities were almost stranded.

³ *Operative Gynaecology*. By Harry Sturgeon Crossen, M.D., F.A.C.S. Second edition. London: Henry Kimpton, 1920. (Roy. 8vo, pp. 744; 854 figures, 63s. net.)

⁴ *Public Health and Insurance: American Addresses*. By Sir Arthur Newsholme, K.C.B., M.D., F.R.C.P. Baltimore: The Johns Hopkins Press, 1920. (Cr. 8vo, pp. 284, 2.50 dols.)

So far as the addresses are merely historical they are interesting and useful, and so far, too, as they deal with suggestions for the administration of public health services they deserve the consideration due to the views of an expert in public health work. But so far as they deal with criticism of national insurance they need to be received with caution.

ANAESTHESIA IN DENTAL SURGERY.

FIFTEEN years ago, as the authors remind us in their preface, there were publishers who said "no field" to their book on *Anaesthesia in Dental Surgery*.⁵ The dental profession, however, gave a more favourable verdict, and, in spite of competitors, Messrs. Luke and Ross found themselves called upon, over a year ago, to revise, enlarge, and edit a fourth edition. We must apologize for an accidental delay in noticing it. A chapter on ether and chloroform has been added in the new edition, and is well up to the standard of this deservedly popular book.

The authors' advocacy of ethyl chloride, and their description of the nitrous oxide, oxygen, and ethyl chloride sequence will do much to popularize the use of this drug, but we trust the same will not hold good in the case of the method of "multiple puncture," which is the only way of using local anaesthetics referred to in the chapter dealing with local anaesthesia. This chapter, indeed, needs re-writing, and "regional anaesthesia" should replace "multiple puncture."

Discussing prolonged "gas" administration, the authors seem to endorse the claim that there is a stage of analgesia before loss of consciousness, in which analgesic stage painful dentine can be drilled and live pulps extirpated without pain. Many have never found this stage, and would be grateful if the authors would more clearly define the method of its production. Our opinion of the book remains as before—an excellent work, and well worthy of careful reading.

NOTES ON BOOKS.

THE sixth edition of *Wheeler's Handbook of Medicine*,⁶ edited by Dr. JACK, follows the fifth edition at an interval of four years, and its reprint dated 1918. It has been carefully brought up to date, augmented, and rearranged, and the editor is to be congratulated upon the large amount of information he has succeeded in compressing into this small and handy volume. Considered as literature it makes rather breathless reading, perhaps: but it is a book beloved of medical students for its precision and dogma, and it may be said to exhibit the merits that make for success.

The fifth edition of Dr. AITCHISON'S *Medical Handbook*⁷ is designed to provide the general practitioner and the medical student with a *valde mecum* written on clinical lines. The diseases affecting the various systems of the body are considered in successive chapters, and there are special accounts of *post-mortem* examinations, prescribing, and various clinical tests at the end of the volume. Pathology and treatment receive adequate consideration throughout its pages. Dr. Aitchison writes from a soundly conservative point of view, and his little book, which contains a large amount of useful information, should be of service to many practitioners of medicine.

The addresses delivered at the Cardiff meeting of the British Association have been published in a volume with the title *The Advancement of Science, 1920*.⁸ The volume opens with the presidential address by Professor Herdman, and this is followed by those given in the various sections.

The *Hazell Annual*⁹ for 1921 has all the characteristics of this well arranged yearbook. It contains a great amount of condensed general information, and forms a

⁵ *Anaesthesia in Dental Surgery*. By Thomas D. Luke, M.D., F.R.C.S. Edin., and J. Stuart Ross, M.B., F.R.C.S. Edin. Fourth edition. London: William Heinemann (Medical Books), Ltd. 1919. (Cr. 8vo, pp. 255; 22 figures. 8s. 6d. net.)

⁶ *Wheeler's Handbook of Medicine*. By William R. Jack, B.Sc., M.D., F.R.C.P. Sixth edition. Edinburgh: E. and S. Livingstone. 1920. (Cr. 8vo, pp. xv + 561. 12s. net.)

⁷ *A Medical Handbook: For the Use of Practitioners and Students*. By R. S. Aitchison, M.D., F.R.C.P. Fifth edition, thoroughly revised. London: Charles Griffin and Co., Ltd. 1920. (Fcap. 8vo, pp. xvi + 390; 41 figures. 10s. 6d. net.)

⁸ London: John Murray. (6s.)

⁹ *The New Hazell Annual and Almanack for the Year 1921*. Edited by T. A. Ingram, M.A., LL.D. Thirty-sixth year of issue. London: H. Frowde, and Hodder and Stoughton. 1921. (Cr. 8vo, pp. 832. 7s. 6d. net.)

useful work of reference. The present edition retains the text of the Covenant of the League of Nations, and gives a short history of the position of the League up to date. An exhaustive account of the casualties and losses in the great war is found at the end of the volume; and tables are included of the post-war strength of the navies of the great powers. The sections devoted to Government departments, the colonies, and education are particularly full. This year the invidious task of trying to give within a few pages an adequate retrospect of medical progress during the past twelve months has been abandoned.

APPLIANCES AND PREPARATIONS.

An Improved Knee-cap.

MR. E. MUIRHEAD LITTLE (London, W.) writes: A perfectly fitting knee-cap—that is, one which closely embraces the joint in all positions of flexion, as well as in full extension—is probably unattainable, but it has seemed to me that it might be possible to improve upon the types usually supplied. Most knee-caps, if adjustable at all, are

made so by the use of eyelets and laces. When these laces are tightened they draw the upper and lower borders of the knee-cap towards one another and thus favour the already existing tendency of the appliance to wrinkle transversely. Moreover, when the lace is tightened the knee-cap is tightened throughout its length, and more than one lace is required if it is desired to tighten one part more than another. Some years ago, on the suggestion of a patient, I substituted straps and buckles for the eyelets and laces of the ordinary knee-cap and found them a great improvement; afterward, the knee-cap, which is shown in the annexed figure, was evolved. I have been in the habit of prescribing this kind of knee-cap for some years, and my patients have found that it is more comfortable and gives much better support than the ordinary laced or not-adjustable knee-cap. The following is a detailed description:



The knee-cap illustrated herewith is made in high grade stout drill and best quality elastic web, so fitted in strands overlapping one another as to prevent any bulging when the knee is bent, which would happen if the elastic were in one piece. A soft pad is placed over the front of the patella as an extra protection, while the back of the knee is cut out to allow free flexion. The adjustment is made by the webbing straps; this allows of more or less pressure being applied at any particular point that may be necessary, which is impossible with lacing. The whole appliance is made upon specially constructed models in order to ensure a perfect fit. It has been made for me by Mr. Albert Edward Evans of 33, Fitzroy Street, W.1, who has most successfully carried out and improved upon my suggestions.

THE TEACHING OF RADIOLOGY AND ELECTROLOGY.

WHEN Röntgen first called attention to the fact that x rays had the power of penetrating substances hitherto believed to be opaque to all forms of light, and of impressing upon a photographic plate shadows of such substances according to their density, the medical profession was prompt to apply this wonderful property of x rays to diagnostic uses. The war impressed the public with the value of x rays in diagnosing injuries to bones and in localizing projectiles, but the public at large, and even the medical profession itself, scarcely realize how far radiology has already progressed, how wide is its literature—journals in England, the United States, France, Germany, Austria, Italy and Spain being specially devoted to it—and how it has become a branch of medicine needing not only a special training and experience, but claiming a whole-time devotion on the part of those who take it up.

The apparatus used has become increasingly complicated, and the technique more exacting, and, even were its present applications only those mentioned above, the interpretation

of shadows, though easy enough in many cases, is exceedingly difficult and sometimes misleading in others, for even the skilled worker makes oversights and errors in diagnosis. But the diagnosis of diseases of the alimentary tract by means of a meal opaque to x rays has opened a new field of research, which has already yielded results of great value, and calls for still more skill and experience in interpretation. Another promising field of usefulness is the therapeutic effect of x rays, properly administered, upon superficial skin lesions and upon deep structures like myomata of the uterus. In malignant disease, also, x rays have been shown to have a profoundly modifying effect, in most cases retarding and in a limited number definitely curative.

Electrology has become a sister subject, claiming also the whole-time devotion of certain of its specialists. It includes the use of various forms of electrical currents—faradic, galvanic, sinusoidal, static—the use of high-frequency currents, and their most recent and powerful developments known as diathermy, especially the surgical uses of this last in cauterizing, either superficially or deep in their substance, the affected tissues.

The Cambridge Diploma.

It is manifest that special training is needed by those who practise this art, and it follows that practice should be restricted to those who can show proof of such training. The first body to take the necessary step was the University of Cambridge, which established, in 1919, a Diploma in Medical Radiology and Electrology, to which we called attention a year ago.¹ The University Committee for the Diploma works in close association with the British Association for the Advancement of Radiology and Physiotherapy, which was the original moving spirit in the matter, and at present courses of instruction are given alternately in Cambridge, arranged by the University, and in London, arranged by the above-named Association, the latter course being recognized by the University as qualifying for the examinations.

Courses of Instruction.

The first course was held in London during the early half of 1920, and there were 22 candidates at the June examination, instruction in physics being given at University College, whilst the teaching in radiology and electrology was given at the Royal Society of Medicine under the aegis of the Fellowship of Medicine, by the combined heads of the radiological and electrological departments of the leading London and other hospitals, with clinical work in the individual hospitals. The second course was held in the latter half of 1920 in Cambridge, the physics being done at the Cavendish Laboratory, and the University Lecturer in Medical Radiology and Electrology receiving most valuable assistance by lectures in Cambridge from many of those who had helped in the first London course. There were 15 candidates at the Christmas examination. A new course—somewhat modified as experience suggested—has just begun in London, the physics being, however, now done at King's College and at the Middlesex Hospital. A further course will begin at Cambridge next June.

The courses extend over six months; they include a special training in physics and electro-technics on the one hand, and in radiology (including the use of radium) and electrology on the other. The lectures in London extend over the whole six months; in Cambridge they are compressed into the Long Vacation and the Michaelmas Term, and arrangements are made for those taking the course there to gain additional experience between the courses of lectures by receiving clinical instruction in various London hospitals.

Further information as to the Diploma and as to the instruction in Cambridge can be obtained from Dr. Shillington Scales, Medical Schools, Cambridge; and as to the London course from Dr. Stanley Melville, at the office of the British Association for the Advancement of Radiology and Physiotherapy, 11, Chandos Street, Cavendish Square, London, W.1.

Lines of Advance.

There is another aspect which should not be lost sight of. The British Association for the Advancement of Radiology and Physiotherapy, as has already been said, was instrumental in getting the University of Cambridge to establish the diploma; it has organized the teaching in London, and its members have given generous assistance to the teaching in Cambridge. Further, it is arranging this year an International Congress in England. The primary object has been to advance the study of its subjects, and incidentally to raise the position of those practising them, so that the radiologist and

electrologist may obtain due recognition and status among their colleagues on hospital staffs. There are now few large hospitals in which this recognition has not been afforded. But above all, the association has shown the workers in these subjects the value of combined effort rather than of isolated individualistic work. If progress is maintained along such lines, or along modifications of such lines, we may see built up a British school of radiology and electrology which should attract workers from far and near, who, instead of attending the clinic of a single teacher, may obtain in their six months' course of tuition for the diploma both a special training and a knowledge of the special work of the leading English radiologists and electrologists. Funds are urgently needed to establish a small institute where research work can be undertaken.

THE OSLER MEMORIAL.

We announced some months ago that a representative committee had been formed for the purpose of raising a fund to provide a memorial to the late Sir William Osler. It was considered that the most appropriate form of memorial would be an Osler Institute of General Pathology and Preventive Medicine in Oxford. Osler began his life with his chief interests directed towards pathology, and he ended it with an enthusiastic belief in the future of preventive medicine. A large general committee was formed, and a smaller executive committee, of which the Bishop of Ripon—then Dean of Christ Church, Osler's college—was the chairman, and Dr. J. A. Gunn, professor of pharmacology in the university, the honorary secretary. The proposed form of memorial was approved at a public meeting held in Oxford on March 6th, 1920, and has met with general approval.

A preliminary list is given below of subscriptions which have already been received from members of the medical profession towards the fund which is being raised for a memorial to the late Sir William Osler. It is hoped that there may be others, whose attention has not been drawn to the memorial, who may wish to contribute. The fund now amounts to about £1,800.

Subscriptions may be sent to the Osler Memorial Fund, National Provincial and Union Bank of England, 91, High Street, Oxford.

LIST OF MEDICAL SUBSCRIBERS.

- £100.—Professor T. K. Monro.
 £75.—Dr. A. E. Hurst, Professor A. W. Mackintosh.
 £75 15s.—Dr. Wm. Collier.
 £72 12s.—Dr. P. H. Adams.
 £70 10s.—Sir Clifford Allbutt, Dr. F. Buzzard, Sir A. E. Garrod, Sir R. W. Philip, Professor Arthur Thomson, Dr. Howard Bullock, Dr. Harvey Sutton.
 £70.—Mr. A. P. Dodds-Parker, Dr. A. G. Gibson, Sir Wilmot Herringham, Dr. J. A. Ormerod.
 £55s.—Professor Adami, Dr. H. Barnes, Dr. Duigan, Dr. R. Hutchison, Dr. E. Hobhouse, Dr. Percy Kidd, Dr. Geo. Mackay, Dr. E. S. Reynolds, Sir Seymour Sharkey, Dr. H. S. Souttar, Professor C. S. Sherrington, Dr. Amley Walker, Dr. A. T. Waterhouse.
 £5.—Sir F. H. Champneys, Sir Walter Fletcher, Sir Alfred Keogh, Professor Harvey Littlejohn, Sir F. W. Mott, Sir Donald MacAlister, Professor G. A. Murray.
 £4 4s.—Dr. R. O. Moon.
 £3 5s.—Professor Finlay, Professor Gunn, Dr. Dunbar Hooper, Dr. J. H. Morgan, Sir H. D. Rolleston, Dr. J. F. Robinson.
 £2 7s.—Dr. E. Bramwell, Dr. W. H. Fears, Dr. J. Griffiths, Professor Halliburton, Sir A. Newsholme, Dr. F. G. Penrose, Dr. Raymond Crawford, Sir Felix Semon, Dr. Cecil Wall.
 £1 1s.—Dr. P. H. Dickson, Professor F. H. Edgeworth, Sir John Goodwin, Dr. J. B. Hurry, Dr. Hinds Howell, Professor A. J. Hall, Dr. Clive Riviere, Dr. A. Whitfield.

M. LAVERAN, a physician and pathologist whose discovery of the malarial parasite has made his name so well known, is succeeded as president of the Académie de Médecine, Paris, by M. Richelot, surgeon to the Paris Hospitals. M. Bonquetot, professor of pharmacy in the School of Pharmacy of the University of Paris, has been elected vice-president, and according to the rules of the Académie will be president next year.

As the result of a report by Dr. Richard P. Strong, director of the League of the Red Cross Societies, the Spanish Red Cross has undertaken an antimalarial campaign in Spain under the direction of Professor Massimo Sella, assisted by Professor Giuseppe Pittaluga. The campaign will start in Camarea, which is the most malarial province in Spain.

¹ BRITISH MEDICAL JOURNAL, January 10th, 1920, p. 55.

British Medical Journal.

SATURDAY, JANUARY 23RD, 1921.

SHORT LIFE TABLES.

MORE than seventy years ago Dr. Farr wrote as follows: "As it might be expected, from the similarity of the human organization, that all classes of men would, *ceteris paribus*, live on an average the same number of years, it becomes important to ascertain whether this be the case; and if it be not, to determine to what extent life is shortened in unfavourable circumstances. The life table answers this purpose; and is as indispensable in sanitary inquiries as the barometer or thermometer, and other instruments in physical research." When Farr wrote those words the life table as a statistical instrument was already of a respectable age, since to John Graunt and to Edmund Halley must be assigned the credit of its invention (Graunt had the idea, but Halley constructed the first table). But the vicissitudes of the life table through the eighteenth century were not such as to commend its use to the sanitarian, since most of the tables, including the most famous of English tables, were constructed on unsound principles, and one involved the nation in heavy pecuniary loss. Hence practical men, even if unable to point out the theoretical error, were alive to the incorrectness of the conclusions drawn. So far as concerns the commercial or insurance aspects of the problem, the earlier mistakes, particularly that of Dr. Price, who constructed the Northampton table virtually from a summation of deaths without allowance for the increase of population at risk, had been recognized and corrected before the time of Farr, but to Farr belongs the whole credit of adapting the life table method to the purposes of the medical profession.

After Farr's time there was little danger of a repetition of old mistakes in this matter by instructed students, although even now one occasionally meets with inferences drawn from a comparison of mean ages at death, the means having been deduced from deaths in a non-stationary population. The employment of the life table by sanitarians did not, however, become general. The reason was that the more correct method of construction was laborious and technical. To construct a rough life table from deaths (the old method) is extremely easy; provided the deaths are given at age intervals of a year, the construction merely involves a little elementary arithmetic. Unfortunately the result in a varying population is altogether misleading. If the population is increasing, we shall have too many deaths at early ages, since the deaths at older ages occur among the survivors of a smaller population, so that the mean age at death and expectation of life will be too low. If, as in the correct method, we take into consideration the census of the living, to build up the life table does not, indeed, demand a knowledge of very recondite mathematical processes, but it does involve some facility in the manipulation of uncouth algebraical formulae and a very great amount of arithmetical labour.

Dr. Farr was, of course, aware of this difficulty and devised a short method of constructing life tables, but the approximations to the true values were not very close, and his plan did not become generally recog-

nized. Several other short cuts have been proposed, one, discovered by Mr. George King and published in 1914 in the first part of the Supplement to the Seventy-fifth Annual Report of the Registrar-General, leaves little to be desired in point of accuracy, but is still perhaps somewhat formidable to the busy medical officer of health. The most valuable discovery, from the point of view of the medical officer of health, made in this field we owe to Dr. John Brownlee.¹ From the sanitary aspect, as Farr recognized in the quotation with which we began, the expectation of life is the "life table constant" which one chiefly desires to know. Now it should have been evident, but until pointed out by Dr. Brownlee it was not evident, that the expectation of life at any age must be some function of the population death rate at and above that age. Dr. Brownlee accordingly set to work to discover the form of the law and found it to be extremely simple. By the aid of the formulae he devised it was possible to calculate with little trouble the expectation of life at any age in a population respecting which the death rates at ages were known. Thus, to take an example, the true expectation of life of males (London, 1911-12) at age 20, as deduced by a complete method, was 42.35 years. Applying Dr. Brownlee's method to the crude data we reached, at the expense of half an hour's arithmetic, the figure 42.40. Without a mechanical calculator the time involved might have been as much as an hour.

Contemporaneously Dr. E. C. Snow was attacking the problem, and dealt with several other constants of the life table upon similar lines. The work naturally interested Sir Bernard Mallet, the Registrar-General, and Dr. T. H. C. Stevenson, whose work as Superintendent of Statistics at the General Register Office has justly earned him the highest praise to which a vital statistician can aspire—that of being a worthy successor to Dr. Farr. In the result, Dr. Snow's method was submitted to extensive tests in the General Register Office, and has now (after many years' delay occasioned by the war) been published as Part 2 of the Supplement to the Seventy-fifth Annual Report of the Registrar-General.²

The Blue Book contains not only a full and lucid explanation of Dr. Snow's method, with worked examples and tables which will greatly simplify the task of a computer, but also the deductions by the method of the chief life table constants for the administrative counties, the large county boroughs, and the larger rural and urban aggregates, based on the mortality experience of 1911-12. So rich a statistical feast has rarely been spread, even by the General Register Office. In discussing it, attention must of course be paid to the Registrar-General's preliminary caution: "The question how far the mortality disclosed in the years 1911 and 1912 represented the normal mortality of the district or how far it is, in fact, adversely abnormal by reason of any particular cause—for example, an epidemic—should be carefully considered." Attention must further be directed to the influence of errors of sampling upon the constants deduced from an analysis of the slender data yielded by sparsely populated areas. All these reserves being made, the contrast of different types of population is striking, if less glaring than those of the (incomparable) "mean ages at death," which daunted Chadwick. Let us, for instance, consider the expectation of life at age 20 of males computed by this method for typical areas. As instances of close aggregation and high industrialization we may take the County of London and the County Boroughs of Liverpool,

¹ *Journ. of Hygiene*, xiii, 1913, p. 178.

² Cmd. 1010, 1920. Price 1s. 6d. net.

Birmingham, and Sheffield. For these four great centres of industry the expectations of life of males at the age of 20 are 42.38 years, 38.48 years, 42.61 years, 41.65 years. Now let us choose four fairly populous non-industrial areas, namely, East Suffolk, Lincolnshire (Holland), Wiltshire, Oxfordshire. The figures are 47.94, 47.03, 47.07, 47.57.

It would not indeed be scientific to infer from such figures that the choice, or necessity, which determines a man to lead his life in an industrial centre rather than in the country is equivalent to an average sacrifice of from five to nine years' existence. A standard based upon other life table constants, perhaps upon the proportion of years lived between the ages of, say, 20 and 50, would be more suitable. Yet these figures are significant of much, decidedly more illuminating than those which led to the catchword of "a C3 population." We are now within sight of a real measure of the difference in terms of health separating a rural from an industrial population.

It is a pity that no similar comparison can be instituted for the one extinct polity which, like our own, had a highly developed industrial system associated with great cities. The external features of city life in Rome are well known, and Professor Frank, of Johns Hopkins University, has recently³ collected evidence showing that in certain industries, notably brickmaking and the manufacture of table ware, capitalist mass-production was highly developed by the end of the first century of our era. In 1913 that accomplished scholar and statistician, the late Dr. W. R. MacDonell, attempted to compute the expectation of life in different provinces of the Roman Empire, and concluded that there was an immense difference between Roman Italy and such provinces as Lusitania. Dr. MacDonell was, of course, obliged to compute his life tables from deaths only (his data were the inscriptions on tombs), so that his comparison with modern life tables may, to some extent, be vitiated by the error mentioned above. Yet the question is of high interest, since industry in the old civilizations was largely carried out by slave labour, and we wish to know how much of the contrast between town and country can be diminished by conscious effort and how much is beyond our means of control.

We are, however, straying from the path upon which we entered, and will conclude our journey with the expression of our gratitude to Dr. Snow, to Sir Bernard Mallet, and to Dr. Stevenson; the work they have carried out forms one of the most valuable contributions to vital statistics of recent years.

OPERATIONS ON TONSILS AND ADENOIDS IN OUTDOOR CLINICS.

WE have published lately a considerable number of letters upon the risks and complications of operating on tonsils and adenoids in outdoor clinics. Attention has thus been focussed upon an important subject first raised in our issue of November 1st, 1919, by Mr. Douglas Drew, and brought to a head on December 11th, 1920, by Mr. E. Watson-Williams's article, from which arose the present correspondence.

Mr. E. Watson-Williams showed that the morbidity among children operated upon in the out-patient department of the Bristol Royal Infirmary was more than four times as great as among in-patients; among 239 out-patient cases, in 1919, he had had 10 cases of morbidity (that is, of more or less serious complications), and one death, directly traced to septic infection after the operation for tonsils

and adenoids; while among 100 in-patient cases in 1918-1920 (comprising those patients admitted because they did not appear robust, and a few cases in which submucous septal resection was done as well) there was only one instance of definite morbidity, and that of a much less serious kind than those recorded among the out-patients. Mr. Watson-Williams's out-patient cases, moreover, were carefully selected; no sickly child, and no child living outside Bristol itself, was included; the parents were given printed instructions for use before and after operation; the children were inspected before being sent home; the parents were directed to wrap them up well, not to allow them to walk a step, to keep them indoors for four days, and to bring them on the fifth and twelfth days afterwards for inspection; and antiseptic lozenges were prescribed. Measures on much the same lines are carried out in many other hospitals, and seem to be the best that can be done in the circumstances under which the surgeon, whose duty it is to perform such operations, has to do his work. It can hardly, however, be considered good surgical practice to leave without proper post-operative treatment, and often amidst bad surroundings, exposed to septic discharges, a raw wound of considerable size, such as is produced by this operation. Yet the choice for the surgeon at present lies between operating under such unsatisfactory conditions or not operating at all; and, on the whole, the gain to health by performing the operation is greater, taking the risks duly into consideration, than by not performing it.

In order to bring about any change there must be some unanimity in the medical profession, not only upon the best method of dealing with the children operated upon, but upon the seriousness with which the operation is to be regarded. The public and a large number of practitioners have come to look upon it as a trivial proceeding. This may partly be explained by the frequency of its performance—it is perhaps the commonest surgical operation done under general anaesthesia—and by the high degree of technical skill, the result of constant practice, displayed by throat surgeons in performing it. We are told, on the authority of Sir William Milligan and others, that some surgeons are known to perform the operation upon private patients at their consulting rooms, and to send them home by taxicab or by train a few hours later. In an operation in which, as has been pointed out by our correspondents, deaths from the anaesthetic are still too frequent, and such complications as acute otitis media, acute mastoiditis, bronchopneumonia, acute sepsis, glandular infection, and serious haemorrhage are not uncommon, this procedure would seem to be indefensible, the more so because the complications enumerated are almost unknown if the patient is kept in bed and properly nursed for two or three days after operation. The consensus of opinion among the leading authorities is that the operation should be regarded more seriously altogether, and that the patient should be admitted to hospital for at least forty-eight hours, as by that means the risk of morbidity can be almost eliminated.

The difficulty is that most hospital authorities are so circumstanced at present that they can hardly be asked to provide the necessary beds for the admission of patients after such operations, even for forty-eight hours. Nevertheless it may be pointed out that this has been done at Portsmouth Eye and Ear Hospital, and, to a modified extent, at Ancoats Hospital, Manchester. Local health authorities, on the other hand, have powers to make provision not only for the performance of this operation by payment of fees to the hospitals, as many of them do at present,

³ *An Economic History of Rome*, Baltimore, 1920.

but also to provide suitable places for the performance of the operation and beds for post-operative convalescence. If education committees through their medical officers take the responsibility of insisting on children being operated upon—sometimes in the face of opposition from the parents—they should, we agree with Sir William Milligan, provide beds at least for those whose homes are unsuitable for safe post-operative treatment. If the beds cannot be found in the voluntary hospitals they might perhaps be provided, as Dr. P. Watson-Williams has suggested, in the Poor Law hospitals, where clinics could be established in charge of surgeons experienced in this branch of surgery, and the guardians, as in other cases, could charge the relatives of the patients for maintenance and treatment in accordance with their means.

STUDIES IN CEREBRO-SPINAL FEVER.

OF the medical problems connected with the segregation of large bodies of men in camps for military training none was more alarming or more difficult of solution than that of cerebro-spinal fever, and the fact that the disease at no time affected large numbers of the population is eloquent of the effectiveness of the measures adopted for controlling it. The mysterious sporadic outbreaks of meningitis baffled explanation, and the high mortality attending them made a scientific therapy a matter of extreme urgency. No one, however, not conversant with the state of our knowledge of the causal agent can appreciate the immense amount of pure laboratory work necessary before therapeutic measures could even be started. It was easy enough to recognize the infecting organism in the spinal fluid of those affected, but quite a different problem to ascertain its mode of conveyance and the conditions under which it spread. It cannot yet be said that we know how it penetrates the outer defences of the body. A delicate organism to grow, it necessitated much experimentation for the elaboration of some special artificial medium particularly favourable to its growth, and its differentiation from several other similar bacteria found in the nasopharynx was neither sure nor easy. The preliminary investigations on these points by Dr. Mervyn Gordon and his collaborators were fruitful in results, and the War Office is to be congratulated not only on the promptitude with which it called in expert assistance but also on its choice of the bacteriologists. A former publication of the Medical Research Council (No. 3) dealing with the earlier part of the work is now out of print, but the more recent report¹ (No. 50) issued last year embraces practically all of it, and adds the later, and perhaps more important, essays in the preparation of curative serums. The present report, covering the four years' work, is arranged under three main divisions. The first part, mainly recapitulatory, deals with the state of our bacteriological knowledge when cerebro-spinal fever first broke out amongst the troops, and gives an account of the measures taken to cope with it—points with which most people are now familiar. The second part comprises studies on the serological differentiation of meningococci from other organisms and their classification into strains, on the nature of the endotoxin, and on antibody formation. Dr. Gordon's four types of meningococci are now universally known, and for the most part, in spite of much criticism by bacteriologists on relatively minor points, his work has received confirmation and has met with the appreciation which it fully deserves. Part III of the report deals with the application of these and other studies to the prevention and treatment of cerebro-spinal fever. A striking account is given of the way in which over-

crowding raises the percentage rate of carriers and how such a rise can certainly be taken as a premonitory sign of an approaching outbreak. By such careful observations the outbreak may possibly be entirely prevented, or at any rate reduced to negligible proportions. Working with the knowledge obtained from the study of the different types of meningococci, Dr. Stanley Griffith of Cambridge succeeded in producing a very potent serum against the endotoxin of Type I, though less success attended the efforts to produce antitoxin against the other types. It is difficult to obtain a standard for comparison, owing to the varying mortality of outbreaks, but, generally speaking, the use of curative serums was attended with a much diminished death rate from the disease—a diminution of nearly 50 per cent. The most obvious success was obtained with Type I antiserum: a patient with meningitis due to organisms of this type was given nearly nine chances out of ten of escaping death. This report on cerebro-spinal fever is one of the best publications of the Medical Research Council, and will long remain the standard work on the subject and the foundation on which future investigations will be conducted. Much of it, no doubt, will appeal more to the bacteriologist than to the general practitioner, but the reading of it by anyone will show the magnitude of the problems that confronted Dr. Gordon and his band of fellow-workers and the high degree of success that attended their efforts.

PSYCHOTHERAPY.

TO the current number of the *Edinburgh Review* Dr. William A. Brend contributes an article on psychotherapy, and the experience which has been gained in the treatment of neurotic disorders resulting from the war. He traces briefly the development of the new psychology; he indicates the nature of the difference of outlook between the various schools of thought; he explains the principles upon which psycho-analytic methods are founded; he suggests the directions in which the application of these principles would seem to be of value; and he raises a timely note of warning against the indiscriminate and unnecessary use of psycho-analysis. The tone of the article is sympathetic, and it comprises a clear and balanced survey of a difficult subject, which will be found of value to the readers for whom it is intended. In commenting upon the advances which have been made in psychotherapy during recent years, Dr. Brend makes certain constructive suggestions as to future developments. He shows that the results of treatment at the clinics for nervous pensioners have been exceedingly gratifying, and he urges the necessity for the greater provision of similar treatment for the ordinary civilian population. That there are directions in which such provision is now being made Dr. Brend shows in his references to the Maudsley Hospital, in which very useful work in investigation and teaching is being carried out under the guidance of Sir Frederick Mott, to the courses of instruction provided at some of the larger hospitals, and to the establishment during recent years at some of the universities of diplomas in psychological medicine. In spite of these developments Dr. Brend urges that more provision is urgently necessary, and he raises a plea for the establishment, closely associated with a clinic, of a well-endowed central school for the teaching of psychotherapy. In emphasizing the need for voluntary financial help in this matter, the views of Dr. Brend are in accord with those expressed by others who are interested in the same question. Dr. E. Gedall, of Cardiff, who has taken an active part in the development of psychiatric clinics, has on more than one occasion emphasized the necessity for support from wealthy members of the community, and it is particularly interesting to note that Professor Kraepelin of Munich has recently shown that State aid does not suffice to meet the needs of the case.¹

¹ Special Report (No. 50) of the Medical Research Council. Cerebro-spinal Fever: Studies in the Bacteriology, Preventive Control, and Specific Treatment of Cerebro-spinal Fever among the Military Forces, 915-1919.

¹ Professor Emil Kraepelin: The German Institute of Psychiatric Research, *Journal of Nervous and Mental Diseases*, June, 1920.

In giving an account of the Psychiatric Institute at Munich, the famous German psychiatrist shows that more money is needed for a research institute on a large scale, and that the State, hampered as it is by financial difficulties, cannot be counted upon to provide this. He suggests, also, that this method of founding institutions is possibly better for their healthy growth, as it gives them greater latitude. The suggestion is of the more interest since it comes from within the Reich, where university and other educational institutes have been accustomed to rely on State aid. We would express the hope, should the rich benefactor be found, that an institute of this kind would not confine its aims to the teaching of psychotherapy, but that it would enlarge its scope to include all the manifold problems of mental disorder.

VIENNA AND LONDON.

LAST September Dr. George E. MacLean, Director of the British Division of the American University Union in Europe, addressed a letter to this JOURNAL stating that he had been informed by a young physician from one of the Middle Western States of the United States that a committee in Chicago was circularizing physicians in his State, saying that an excursion had been organized for physicians to Vienna for study, as before the war American physicians were accustomed to do. The Chicago committee gave assurances that the way had been prepared for the reception of these medical men in Vienna. We have now received a letter, dated January 15th, from Professor Wenekebach, director of the first medical university clinic in Vienna, stating that neither the Viennese medical faculty nor the official organization for post-graduate courses know anything of this propaganda. He encloses a programme of the first official course of lectures which will be given in Vienna next month; it extends over a fortnight, and is confined to internal medicine. The lectures will be given by the professors of the Vienna medical school, and each will deal with a subject to which he has given special attention; at the opening course on February 7th Professor Wenekebach will speak on cardiac insufficiency and on the value of quinine in that condition. On the same day Professor Winterberg will give a demonstration of the value of the electro-cardiograph in diagnosis. On February 8th Professor Pal will deal with arterial sclerosis; on February 9th Professor Falta with nephritis, and so on day by day until February 19th, when Professor Eonomo will lecture on encephalitis. The fee for the course is to Austrians, Hungarians and Poles, 200 k., to Germans, Czecho-Slovaks, Bulgarians, and Armenians 500 k., and to persons of other nations, 1,000 k. It is proposed to arrange other courses in June and December. Further particulars can be obtained from the office of the *Wiener medizinische Wochenschrift*, Wien, IX, Porzellan-gasse 22, when help in finding lodgings will be given. In a previous article it was stated that we were informed that the invitations issued by the American committee were accompanied by assurances of plenty of food and comfortable accommodation. On this point Professor Wenekebach tells us that, as a matter of fact, a foreigner coming with any sort of sound money will be in a position to live in Vienna quite cheaply and to get everything he wants at a price low for him. "At the same time," he states, "all the good things of life are out of reach for the Vienna people itself, because it is absolutely unable to gain enough crowns for paying such prices. The fee of a thousand crowns would mean for an Englishman something like five shillings." Professor Wenekebach goes on to suggest that it might be possible to arrange some co-operation between Vienna and London in respect of post-graduate study. The position in London, where the work of the Fellowship of Medicine and Post-Graduate Medical Association continues, is unchanged at present, but it is to be hoped and expected that the inquiries of the committee on post-graduate education just appointed by the Ministry of Health will contribute towards a satisfactory outcome.

EXPERIMENTAL INFECTION WITH LEPTOSPIRA ICTEROIDES.

In the twelfth instalment of his researches in connexion with the etiology of yellow fever Noguchi¹ reports the results of experiments to show how *Leptospira icteroides*, the causal organism he has isolated and named, reacts to salvarsan and neo-salvarsan, both *in vitro* and in the animal body, and also to salvarsanized serum. In addition an interesting comparison is drawn between the action of these arsenical preparations and that of anti-icteroides immune serum upon *Leptospira icteroides* in experimental infections and *in vitro*. Much interest attaches to the way in which *Leptospira icteroides* is affected by salvarsan preparations, as it was found by Inada and Ido, and by Noguchi in some unpublished observations made in 1917, that infections with the closely allied *Leptospira icterohaemorrhagiae*, the exciting cause of spirochaetosis icterohaemorrhagica, are not therapeutically influenced by these drugs, and that there is thus a difference from infections with other genera of the Spirochaetoida. Experiments now published by Noguchi show that from the therapeutic standpoint the salvarsan preparations are not of any value in experimental infection of guinea-pigs with *Leptospira icteroides*. Several series of test-tube experiments made to determine the direct effect of salvarsan and neo-salvarsan on this organism showed that these drugs exert a slow but highly poisonous influence on the leptospira, a culture of which is killed in twenty-four hours by salvarsan in dilutions of 1 in 20,000. The discrepancy between the absence of any effect *in vivo* and the destructive influence *in vitro* of salvarsan on the leptospira suggested an investigation of the action of salvarsanized serum; in serums from rabbits that received intravenously 0.05 gram of salvarsan or neo-salvarsan per kilo of body weight before bleeding, the leptospira remained active for at least an hour, but became somewhat sluggish after eighteen hours, and were all dead and degenerated in forty-eight hours, whereas leptospira mixed with normal rabbit's serum lived and multiplied. Comparison of the time (twenty-four hours) that salvarsan *in vitro* takes to kill the leptospira with the time (forty-eight hours) taken by salvarsanized serum to produce the same result shows that the action of these drugs is slower after passage through the animal than it was before. From this the important deduction follows that if this phenomenon were also to take place in the infected body injected with these drugs, it is clear that in a rapidly evolving infectious disease like yellow fever the progress of the infection will be too rapid to allow the drugs to exert their beneficial effect upon the course of the disease. In direct contrast to the behaviour of salvarsan preparations *in vivo* and *in vitro* is the action of anti-icteroides immune horse serum, which, in a dose of 0.0001 c.c.m., or 1 c.c.m. of 1 in 10,000 dilution, protected guinea-pigs from an infection with at least 5,000 minimum lethal doses of *S. icteroides* when injected simultaneously; but the same serum failed to have any harmful effect when mixed *in vitro* in a concentration weaker than 1 in 2,000. Rapid disintegration of the leptospira occurred in a concentration of 1 in 20, and almost complete agglutination and degeneration with 1 in 200 concentration. The contrast between chemo-therapy, as carried out with salvarsan preparations, and sero-therapy apparently has considerable practical significance.

THE REGISTRAR-GENERALS REPORT FOR 1919.

THE eighty-second annual report of the Registrar-General of births, deaths, and marriages in England and Wales has just been issued as a Blue Book of 520 pages.² The salient features of the vital statistics of 1919 are summarized by Sir Bernard Mallet in his prefatory letter, dated November, 1920, and addressed to the Minister of

¹ H. Noguchi, *Journ. Exper. Med.*, Baltimore, 1920, xxxii, 581-400.

² To be purchased through any bookseller or directly from H.M. Stationery Office. (Cmd. 1017. 7s. net.)

Health. The marriage rate was 19.7 per 1,000; this was the highest on record, and the provisional figures for 1920 indicate a further rise. The birth rate was 18.5 per 1,000, being 0.3 per 1,000 above that recorded for 1918, but 5.3 below that for 1914, which, particularly so far as the birth rate is concerned, may be regarded as the last year unaffected by war conditions. The death rate was 13.7 per 1,000, being, with two exceptions, the lowest on record, notwithstanding the heavy mortality from influenza in the early part of the year. Infant mortality was 89 per 1,000 births, being the lowest rate hitherto recorded, though when allowance is made for a falling or rising birth rate, the rate for 1916 appears to have equalled it. The provisional figures for 1920, printed at p. 178, indicate a further fall, both in the general death rate and in infant mortality. As in other recent reports the mortality of infancy and early childhood is examined in special detail. The death rates from measles, whooping-cough, and enteric fever were by far the lowest on record; on the other hand, deaths from small-pox were more numerous than in any year since 1905. Notwithstanding the influenza epidemic, the mortality from tuberculosis was the lowest on record, and that from pneumonia normal. The deaths from cancer were in accordance with the general movement of cancer mortality in recent years, which has increased much faster among males than females, though for several years before 1919 this increase seemed to have been arrested for both sexes. Cancer, however, forms the one great exception to the general tendency for mortality at most ages to decline. The Registrar-General dwells upon the difficulty of making local estimates of population; this always increases as the last census becomes more distant, and the possibility of error was much aggravated by the movement of population caused by the war. We conclude this brief notice of a great statistical work by observing that the estimated total population in England and Wales in the year under review was 36,800,000, amongst whom the females exceeded the males by as much as 2,438,690. Of the men some 800,000 were estimated to be non-civilians.

OUTBREAKS OF FOOD POISONING.

THE Ministry of Health is anxious to obtain early information, as exact as possible, on all cases of food poisoning. It has therefore requested all medical officers of health to notify the Ministry at the earliest possible stage whenever they have reason to suspect that any death or outbreak of illness in their districts is due to food poisoning. Although neither medical practitioners nor the general public are under any statutory obligation to report cases of food poisoning to the medical officer of health, it is hoped that they will co-operate with a view to safeguarding the public health in this direction, the local health authority being prepared now to authorize any necessary inquiries and investigations—bacteriological, chemical, and otherwise—into the possible causes of an outbreak of suspected food poisoning. The chief causes of food poisoning are: the contamination of foods by inorganic poisons (for example, arsenic, antimony, copper, and lead), and bacterial contaminations, the latter being of much more frequent occurrence, especially in the case of foods of animal origin. Care should be taken to secure samples from all available food materials in cases of food poisoning, apart from those to which suspicion attaches at first sight, as it often happens that a food substance which was not suspected in the first instance is ultimately proved to be the material at fault, especially when the illness is suspected to be due to an inorganic poison. The complete history of each case should be obtained with the least possible delay, as the determination of the circumstances in which food poisoning has occurred often turns upon the elucidation of apparently trivial points, and after some days' interval it is impossible to rely on recollection of them. In addition to the examination of samples of suspected food materials, it

is of importance that bacteriological examination should be made of materials from persons affected and particularly of the organs of fatal cases. The exact material required may vary in individual outbreaks, and in all such cases the medical officer of health concerned should consult the bacteriologist entrusted with the examination. His advice should also be obtained in order that the material may be transmitted with proper precautions and in a condition suitable for examination. The serological reaction of the blood of persons attacked, the Ministry emphasizes, should always be bacteriologically investigated.

THE CASE OF DR. DOLLING.

DURING its last session the General Medical Council discussed very fully the case of Dr. Charles Edward Dolling, who was reported to the Council as having been convicted of a misdemeanour at the Westminster Police Court. The magistrate's decision was upheld on appeal at the general Quarter Sessions. As will be seen from the report published in the SUPPLEMENT of December 4th, 1920, p. 155, the case was heard in private; the result was that the General Medical Council decided that Dr. Dolling's name should not be removed from the *Medical Register*. The Council considered the matter *in camera*, but its decision, which we understand was unanimous, shows that it accepted without hesitation Dr. Dolling's version of the facts and circumstances leading up to his conviction, and also accepted the unimpeachable testimony as to character that Dr. Dolling produced. As a member of the medical profession, therefore, Dr. Dolling's character is clear, but he held a commission in the Royal Army Medical Corps. He had been in practice in Adelaide, came to England in 1915, and served continuously until October, 1919. We have examined the papers submitted to us by Messrs. Hempsons, the solicitors who represented Dr. Dolling before the General Medical Council, and agree that there has been a grave miscarriage of justice in the courts, owing, probably, to the imperfect manner in which Dr. Dolling's case was originally stated. The only course open to Dr. Dolling is to appeal for a pardon. This appeal is now being prepared, and if successful will render it possible for him to be reinstated in the army.

HOSPITAL INQUIRY COMMITTEE.

THE Marquess of Linlithgow has been appointed, on the nomination of the Secretary for Scotland, to the Committee on the Finances of Voluntary Hospitals appointed by the Minister of Health, and Sir W. B. Peat, of the firm of W. B. Peat and Co., chartered accountants, has been added to the Committee. The composition of the Committee is now therefore complete. It consists of Lord Cave (chairman), Lord Linlithgow, Sir Clarendon Hyde, Sir W. B. Peat, Mr. R. C. Norman, and Mr. Vernon Hartshorn, with Mr. L. G. Brock, of the Ministry of Health, as secretary. Its terms of reference are: "To consider the present financial position of the voluntary hospitals and to make recommendations as to any action which should be taken to assist them." The first full meeting of the Committee was held on Wednesday, January 26th, when evidence was given in the morning by the Hon. Sir Arthur Stanley, Chairman of the British Red Cross Society and Treasurer of St. Thomas's Hospital, and Sir Napier Burnett, Director of Hospital Services under the British Red Cross; and in the afternoon by Viscount Knutsford, Chairman, and Mr. E. W. Morris, House Governor, of the London Hospital.

COMMITTEE ON POST-GRADUATE EDUCATION.

WE understand that the Ministry of Health has appointed a committee to inquire into the position with regard to post-graduate medical education and to report on the steps which the Ministry should take to assist in placing it on a satisfactory basis. The Earl of Athlone, chairman of the Middlesex Hospital, has been appointed chairman of

never condemned any portion of the present hospital buildings, although one block was condemned by me sixteen years ago and was swept away last year. On the other hand, three modern hospital buildings were completed sixteen years ago, having a first-class operating theatre and accommodation respectively for 156 adults, 80 children, and 45 maternity cases. These new hospital buildings compare favourably with any in the country, and I cordially invite Mr. Hall to revisit them and refresh his memory.

In addition, and within the last four years, three other pavilions have been erected and put into use, each accommodating 100 patients. Thus, at any rate, we have 581 beds to which the expression "same old obsolete" hardly seems to apply. Nor is it any more applicable to the medical and surgical equipment of these or of the other and older wards of the hospital.

Mr. Hall says he would welcome "real co-operation" between the Bradford Royal Infirmary and Municipal Hospital. One of the prime essentials of real co-operation being mutual knowledge, I trust the above facts will be of use. I am afraid, though, that Mr. Hall's idea of co-operation in this case implies the conversion of St. Luke's, with its splendid wards and equipment, into a dump, on to which the Infirmary could shoot its patients after giving them the more exciting portions of their surgical treatment. This would make less risky than it is at present the well known procedure by which has been attained the new boast: "*There is at present no waiting list at the Infirmary.*"—I am, etc.,

B. HOLROYD SLATER,

Medical Superintendent, Bradford Municipal
General Hospital.

Bradford, Jan. 18th.

PROGNOSIS IN ENCEPHALITIS LETHARGICA.

SIR,—In view of the notice which the disease is now receiving, I am authorized by Sir George Newman to send a brief note on its prognosis so far as it appears from the collection of case reports made by me at the Ministry of Health.

A study of these reports, together with an examination of several old cases, shows that in many instances the later stages of the disease may be very prolonged and the source of much anxiety both to the patient and to his medical attendant. Facial and ocular palsies, marked paresis, and sometimes paralysis, of a limb or limbs, and tremors in the parts so affected, are constantly mentioned as existing after the patient has resumed or partially resumed his normal occupation. In addition, the higher faculties are apt to remain for some time distinctly impaired, so that loss of memory, defects of speech, mental lethargy, and a general loss of intellectual tone result. The character, too, not uncommonly becomes changed, and often for the worse, especially in children. It may be noted in passing that MM. Harvier and Levaditi in a recent paper (*Bull. et Mém. Soc. Méd. des Hôp. de Paris*, December 9th, 1920) support the conclusion reached by Marary—namely, that the sequelae of epidemic encephalitis are often no more than the symptoms of a form of the disease with a prolonged evolution.

It will be recalled that soon after the disease appeared in this country, and prior to January 1st, 1919, when encephalitis lethargica became a notifiable disease under the Public Health (Acute Encephalitis Lethargica and Acute Polio-encephalitis) Regulations, 1918, a special inquiry was initiated by the Ministry with the object of gaining information concerning the epidemiology and clinical characters of the disease. The material for investigation and the knowledge then available were both limited, but a full and carefully compiled report on the subject was issued by the Local Government Board in 1918.¹

At the time this report was issued the conclusions reached concerning the full course of the disease in individual cases and the ultimate fate of its victims were necessarily guarded and provisional in character. The mortality rate, for instance, in Dr. MacNalty's series of 168 cases worked out at approximately 22 per cent. Of the 541 cases of encephalitis lethargica notified during 1919 from England and Wales no less than 286 proved fatal, a mortality of 54.6 per cent. A later review of this

¹ Report of an Inquiry into an Obscure Disease (Encephalitis Lethargica, New Series, No. 121).

series resulted in the elimination of a certain number of fatal cases by reason of mistaken diagnoses, but even so the death-rate figure remained at 50 per cent.—a mortality which is probably much higher than is generally supposed. The fatality is greatest in those over the age of 30.

I may add, in view of a comment in your leading article of January 15th, that the Ministry of Health, in conjunction with the Medical Research Council, are actively continuing the investigation of this disease in its epidemiological, clinical, and pathological aspects. This co-ordination has already resulted in the successful transmission of the virus of encephalitis lethargica to monkeys in the Derby case, which was reported in the annual report of the Chief Medical Officer of the Ministry for 1919-20. The detailed information regarding notified cases which we are receiving from the medical staff of institutions, medical practitioners, and medical officers of health is proving of great value, not only as material for ultimate tabulation, but as a guide to the selection of cases for special investigation.

Possibly some of your readers can supply information on the after-history of cases notified during 1919, supplementary to that which they have already sent in reply to schedules of inquiry. Any such information would be specially welcome.—I am, etc.,

ALLAN C. PARSONS,

Medical Officer, Ministry of Health.

Whitehall, S.W., Jan. 24th.

X-RAY RADIATION AND CANCER.

SIR,—Mr. Sampson Handley's important lecture and the letters in the last issue of the BRITISH MEDICAL JOURNAL raise a question that is likely to claim a more or less rapidly increasing attention on the part of the profession. Dr. Lord's criticisms on the absence of any uniform or satisfactory method of x-ray dosage as applied to these cases are well founded, and probably none deplore this more than radiologists themselves. Until quite recently at least, the difficulties surrounding the problem have been very great. Such methods as have been devised have not proved satisfactory in practice, chiefly for the lack of standardization in the various parts of our x-ray equipment, all, or nearly all, of them difficult to standardize.

As to the potential value of radiation in malignant disease, this is no longer a matter for argument. Up to the present, even if the proportion of successful cases has been small, it is at least enough to prove we are on the right road. For several years past I have felt sure that radiation would be more likely to provide the much desired "cure for cancer" than anything else within our present knowledge. Given a suitable type and intensity of radiation there is no reason in theory why any localized malignant growth should not be made to disappear, whether it be superficial or deeply seated. Where we have failed in the past it is chiefly from unsuitable and insufficient dosage. Working with the most highly penetrating rays available, the loss of total radiation between the surface of the skin and a depth of 10 cm. below has been something in the neighbourhood of 90 per cent., more rather than less. At the present time, with one single exception, every x-ray set in the United Kingdom produces a type of radiation that is not sufficiently near the hard gamma rays of radium in character, and not sufficiently homogeneous to be of any real practical value in the treatment of malignant lesions of the more deeply seated parts.

Uniformly successful irradiation under these circumstances is possible only with x-ray tubes having a resistance equivalent to at least 16' of air, in conjunction with a filter thick enough to make the resultant radiation homogeneous. Few radiologists here use filters exceeding 6 mm. of aluminium, whereas to get homogeneous rays with a "gas" tube at least 12 mm. are necessary, and more with the Coolidge tube, since it gives a less homogeneous radiation than the best type of gas tube with water-cooled electrodes. The American Coolidge tube is unsuitable for this class of work owing to the inadequate distance between the electrodes.

Quite recently it was my good fortune to spend a week in the university town of Erlangen, Bavaria, attending several hours daily in the Frauenklinik, under the charge of Professors Seitz and Wintz. The x-ray technique there practised is probably the most efficient in existence, and is

due to the efforts of Professor Wintz and his assistants. Not the least interesting fact is that this highly successful system has been evolved not by a radiologist, but by a gynaecologist, who was profoundly dissatisfied with the results of surgery in that class of malignant cases that come under the notice of the gynaecologist, including mammary carcinoma. One outstanding feature of the system is the method of dosage.

Special apparatus and tubes have been designed to give a type of radiation having qualities of penetration and intensity combined such as has been hitherto unattainable, with facilities for reproducing this standard type of radiation at will. Dosage thus becomes a matter of calculation and time, and the results are uniform and successful to a degree that would be surprising were it not quite in keeping with theoretical considerations. Empiricism is almost entirely absent in the matter of dosage, and after a tube has been standardized by instrumental means its radiation value is checked by biological methods before being put into practical use. Moreover, every tube is recalibrated at regular intervals. It is unnecessary to go into further technical matters, but I may be allowed to refer to some more details regarding dosage. Working under the standard conditions it is found that with the proper filter, focal-skin distance, etc., the maximum dose the skin will stand without serious injury will be given in about thirty-five minutes. This will be followed by reddening of the skin in about a week and tanning in about three weeks after, but no ulceration or other destruction of tissue. This is what is called the unit skin dose. Taking this unit skin dose as 100, it has been found that a cancer cell requires 110 per cent. of this to ensure its destruction; less may do so, but the dose must not be under 90 per cent. A dose of 70 per cent. to 90 per cent. will paralyse a cancer cell, so to speak, but it is not certainly destroyed, and may recover. If, however, a dose of only 40 per cent. of the unit skin dose is given to a cancerous growth, the latter is stimulated, causing it to increase rapidly, with serious, possibly fatal, results. Herein lies the explanation of some of our failures in the past. In our relatively feeble efforts to cure our patients we have attained this "virile" dose, hastening the very end we were doing our best to avert.

In view of these facts—and I have satisfied myself at least that they are substantially correct—a little consideration will show that our methods will have to undergo considerable modification if we are to ensure the degree of success we aim at. Supposing we are dealing with a case of uterine cancer, it is found that when we apply the unit skin dose to the skin over the symphysis only 18 per cent.—approximately—reaches the cervix, dispersion and absorption accounting for a loss of 82 per cent. Consequently we must use at least six ports of entry, all accurately directed towards the growth, if we are to ensure success, and these six doses must be given on the same day. The parametria will have to be similarly treated at intervals of eight and sixteen weeks respectively, such intervals being necessary to allow the blood and tissues to recover. In dealing with mammary and other relatively superficial cancerous growths we are limited practically to one port of entry and our technique has to be modified. The only method of getting even irradiation throughout a superficial growth is to set the tube some distance away—anything from 70 cm. to 100 cm., according to circumstances. Naturally this involves a serious loss by dispersion that can be made up only by a prolonged exposure which may be from five to ten hours or even more. This no doubt sounds formidable and to many may seem difficult, but it is not only practicable but successful. To go further into details would serve no useful purpose just now, and I shall conclude by giving some figures relating to results attained in the Frauenklinik at Erlangen, that give cause for serious reflection. I have been satisfied as to their substantial correctness, and I would ask those who may be disposed to question them to bear in mind that I have been there to investigate for myself, and that the type of radiation and the technique employed are entirely different from anything that has been done in this country up to the present. It will be assumed, of course, that cases in which dissemination had begun were not treated if there was any evidence of this fact.

In the year 1918 twenty-four cases of uterine cancer, with more or less involvement of the parametria, were treated with the x rays alone. At the present moment twenty of these are quite well and leading normal lives, being at least clinically cured. In some, fragments of suspicious-looking tissue were removed for microscopic examination, with negative results. In one case the treatment had no appreciable effect, for reasons that are not clear. In the other three dissemination had begun, though there was no evidence of this at the time. The primary lesions disappeared, but the patients died from distant

extensions. Turning to mammary cancer we find that exactly 75 per cent. of such cases treated in 1917 by the x rays alone are now clinically cured.

With the constant improvement in equipment and technique better results are expected for subsequent years, but that even these results can be attained by means of the x rays alone is sufficiently remarkable to give rise to a conjecture that our present methods of dealing with malignant disease are likely to undergo considerable modification in the near future.—I am, etc.,

London, W., Jan. 22nd.

REGINALD MORTON.

INFECTION OF THE SUPRACLAVICULAR REGION IN CANCER OF THE BREAST.

SIR,—I have been very interested in the letter of Mr. Parry published in the *JOURNAL* of January 15th (p. 99), relating his experience of the frequency with which, when operating for cancer of the breast, he found the glands above the clavicle revealed, on microscopic examination, evidence of cancerous infection. I have, in operating for cancer of the breast, for more than twelve years as a routine practice removed the fatty tissue, and contained glands, from the supraclavicular region, following the practice of some of the American surgeons, as although I recognized that it was not common to find cancerous glands there, yet occasionally they were discovered on opening up the supraclavicular space, though there was no evidence of their presence before operation. The supraclavicular extension of the operation was carried out in all cases except those in which it seemed desirable to shorten the time of the operation for some definite reason, or the primary growth was exceptionally small, and the axillary glands were not found to be involved at the operation. In the cases in which it was carried out it did not materially add to the risk of the operation. If we find in the supraclavicular region cancerous glands, of some size, which have to be removed from under the sterno-mastoid, and are in intimate relation with, or even adherent to, the internal jugular vein, and other important structures at the root of the neck, then removal does, of course, involve a very definite increase of risk, but I am now writing of an extension of the breast operation, which consists in clearing out the fat of the supraclavicular region, and all contained small glands, of the same nature as the routine removal of the axillary fat and glands.

Since reading Mr. Parry's letter I have looked through my records of operation for cancer of the breast from July, 1903, to October, 1911 (three years and three months), and in that period I find I operated on 38 cases. From these we must deduct 8, as in 4 cases the supraclavicular extension of the operation was not performed and in 4 cases glands could be felt above the clavicle before operation. Out of the remaining 30 cases, in only 3 did I find cancerous growth above the clavicle; in most of the cases in which there was no supraclavicular cancerous growth there was cancerous growth in the axillary glands, and in a few quite extensive growth, certainly in one case reaching up above the upper border of the pectoralis minor. But though it is evident that cancerous growth, at least as judged by naked-eye inspection, is not common above the clavicle, yet it is evident that in one case in ten, if I had not as a routine practice cleared out the supraclavicular tissue, I should have left nodules of growth there, and as this extension of the operation to the supraclavicular region involves no material risk, it does seem to me that it should be carried out as a routine practice, except in cases in which for some special reason it is contraindicated. Of course it may be that the small glands I frequently removed with the supraclavicular fatty tissue would, if they had been examined microscopically, have shown evidence of cancerous infection, as the glands Mr. Parry removed did, but I do not think they would. My experience is that one more often finds that a gland one is suspicious may contain secondary growth, is not found on microscopic examination to do so. I cannot say that in the three cases in which I did find nodules of growth or infected glands above the clavicle, those nodules were microscopically examined, but they were absolutely typical to the naked eye.—I am, etc.,

Bristol, Jan. 23rd.

CHARLES A. MORTON.

RISKS AFTER OPERATION ON TONSILS AND ADENOIDS IN OUTDOOR CLINICS.

SIR.—The paper of Mr. E. Watson-Williams, bringing forward the risks and increased morbidity following this method of treatment, deserves the thanks of the profession and public. The correspondence since the publication of this article shows that there is a general agreement as to the unsatisfactory manner in which this work is carried on.

Although I no longer practise this work, I accede to a request to give my opinions on the subject, for I have long felt that it was highly unsatisfactory. After some years I eventually abandoned the out-patient treatment of these cases and only operated on such as could be admitted to the wards, although a large number still continued to be dealt with in the out-patient department.

It seems to me that these hospital patients should have the same facilities that we demand for private patients, first, because it is safer, and any complication, such as reactionary hæmorrhage, can be dealt with readily by the surgeon or his assistants, and, secondly, because it is more humane. The recovery room after such a morning's work as usually obtains in most hospitals performing this type of work is a sight which no one with reasonable compassion can bear to witness. Add to this the preliminary starvation, the horrors of the operating theatre, and the aforesaid room, together with perhaps a tram or train journey afterwards, should make any one pause before countenancing such operations. I speak from personal experience of this method, and it would need a much more facile pen than my own to describe the feelings of a train journey after such an operation. Of course, it may be the lesser of two evils to operate under such conditions rather than not operate at all, but I have remarked on many occasions that were our patients perhaps something less than human we should have probably more humane means of dealing with them. I have also often wondered what an inspector of the N.S.P.C.C. would think could be present during a morning's work!

Our present hospital system, or perhaps rather the want of it, is at the root of the matter, for the poor voluntary hospitals are no doubt doing their best to cope with the large amount of work thrown on to them by the various Government inspecting agencies. It is to be hoped that this matter, which has been ventilated before, may now be settled, so that the better and more humane method may become the established one.—I am, etc.,

Newcastle-on-Tyne, Jan. 24th.

F. C. PYBUS.

SIR.—As Dick Phenyl remarks in *Sweet Lavender*, "Blame, blame, but never a word of praise." Surely one may be allowed to put in a mild and deprecatory protest on behalf of the methods of those of us, not eminent otologists, who week by week have the duty of dealing, as out-patients, with large numbers of children seriously handicapped by adenoids and enlarged tonsils.

At a time when railway bookstalls are pushing the sale of a book by a physician who undertakes to prove that operations on the throat are harmful and unnecessary, is it wise for medical men to join in a loud chorus of condemnation of present procedure, and even to suggest the issue of an appeal to the lay press in popular language? Is it not a fact that the alleged dangers of outdoor clinic treatment have been shown by experience not to be so very great after all? Are not fatalities known in the houses of the rich even when the patients are surrounded by the greatest precautions against disaster, and do no complications ever occur in well appointed nursing homes? At the London County Council school treatment centres printed directions as to treatment before and after operation are given, and the nurses present at the operation follow up the case at home and pay frequent visits. At the Hammersmith School Treatment Centre 1,608 children have been operated on with no mortality, direct or indirect; there has been one case of severe primary hæmorrhage which would have taken place in any hospital, whilst the few cases we have had of secondary hæmorrhage have occurred on the third to the seventh day, showing that twenty-four hours' detention in hospital would not have been of much service.

When one considers the large number of children—stupid, deaf, unhealthy, with restless, unrefreshing nights—who

are converted into normal beings by operation, to say nothing of those chronic otorrhœas which often clear up like magic, ought we not to find matter for congratulation in the net result achieved, and not waste time in advocating the impossible?—I am, etc.,

WALTER E. FRY, M.R.C.S., L.R.C.P.,
Surgeon, L.C.C. Hammersmith School
Treatment Centre.

January 21th.

TUBERCULOUS MILK.

SIR.—Recent correspondence in your columns has revealed considerable diversity of opinion regarding the infectivity of bovine tuberculosis to man. At the last meeting of the Council of the Society of Medical Officers of Health representations on the subject were received from the Tuberculosis Group and individual members of the society, and the following resolutions were adopted unanimously:

- (a) That in the opinion of this society it has been conclusively proved that bovine tuberculosis is transmissible to children through the ingestion of infected milk.
- (b) That this society regards the evidence of immunization by the ingestion of living tubercle bacilli in milk as entirely unproved.

I was directed to forward you a copy of these resolutions for the information of your readers.—I am, etc.,

G. S. ELLISTON,
Executive Secretary, Society of Medical
Officers of Health.

1, Upper Montague Street, W.C.
Jan. 22nd.

THE PREVENTION OF VENEREAL DISEASE.

SIR.—The present controversy regarding venereal disease prophylaxis would be welcomed by the medical profession if the protagonists would call a truce to recrimination and turn their minds to the more profitable channels of constructive policy. To this end they would do well to consider the last paragraph of Sir Archdall Reid's letter.

There are, in fact, two problems of venereal disease prophylaxis to be considered; the one dealing with the present generation is urgent and demands emergency measures. The Society for the Prevention of Venereal Disease is taking such measures. Their remedy is of necessity partial and imperfect, but so long as they realize that their method of attack is adapted only for the urgent needs of the moment, there can be little cause for concern about the effect on the morality of the people.

The second problem, affecting our children and generations yet unborn, requires more careful investigation and wider vision.

Now, there exist in this country three great institutions for the teaching of the young—the home, the Church, and the school. Of these, the home is the ideal place for early and continuous instruction in clean and healthy living; but, unfortunately, home teaching is not available at present on account of the ignorance of the parents themselves. The Church, however, is too preoccupied with creed and observance to realize that the teaching of conduct, rather than faith, is the crying need of our time. For the future it has great possibilities, but for the present we must trust to the school.

In school the growing child can be taught day by day the principles of three great sciences: History, dealing in broad outline with the development of the human race; biology, beginning with the everyday phenomena of plant and animal life, and leading up to the fundamental facts of human life and reproduction; and citizenship, the science of conduct, of the relation of individuals to one another, to the State, and to mankind. The teaching of a clean, healthy way of life is of immediate and paramount importance. In addition, the course of citizenship should include instruction on the great social problems of the day, among which that of venereal disease occupies a significant position.

It is the plain duty of the educational and medical authorities to unite in preparing a thorough systematic course on these lines. The matter is urgent.—I am, etc.,

Sherborne, Jan. 24th.

J. M. MACKINTOSH.

SIR.—Dr. Wansey Bayly, in your issue of January 1st, accused me of indifference to the ravages of venereal disease among the innocent. Such is not the case, and I think there is evidence in the correspondence in the last

few weeks to maintain the view that the innocent can, in the long run, only be protected by a high standard of honour among men. He also said that I ignore the problem as it exists at the present moment, and he then at once went back more than two years—to the war. The men who acquired venereal disease in the war were subjected to an intensity of temptation, combined with a shattering of the nervous system, such as is not the case to-day.

Venereal disease is the price that will always have to be paid for war, and the only way to prevent an epidemic of it in future is to work to prevent war. But it is the healthy young man entering on life to whom the Society for the Prevention of Venereal Disease is issuing its leaflets. To a man who has already acquired it, in the war or after, the word prevention does not apply, and no amount of leaflets or permanganate will prevent him from spreading the disease. His case is met by the venereal clinic.

The mere fact of advocating preventives assumes the possibility of a lapse. Once a man makes that admission he is unsafe and probably will run the risk, and, as the preventives are admittedly not absolutely certain, the fact of advocating them becomes a source of augmenting not decreasing disease. Dr. Otto May's parody in your issue of January 22nd hits the mark, and if one substitutes "Father, to John, aged 18," for "Mother, to Mary, aged 14," the case is complete. I trust that ridicule may be the best weapon to clear the air of this nauseous moral miasm that is being set loose in certain quarters.—I am, etc.,

London, S.E., Jan. 24th.

H. B. GLADSTONE.

MUSCLE RE-EDUCATION.

SIR,—The recent discussion on this subject in your pages ended by revealing apparently irreconcilable differences of opinion amongst different schools of experts as to the fundamental principles of muscular re-education. The question need not be left in this unsatisfactory position, since we have certain working hypotheses by which to test the claims made on behalf of any system of treatment of markedly disabled skeletal muscles. Thus the "submaximal exercise load" and the "limit of fatigue" are recognized guiding principles in all muscular work. Further, all are agreed that "voluntary contraction" of muscle has far more therapeutic value than any vicarious simulation of the same induced by mechanical or electrical stimulation. There is also general agreement that "voluntary" exercise of a weak muscle should be selective for that muscle. The principles of the submaximal load, or the fatigue limit, and of a voluntary selective exercise, are of special importance in re-education of weak muscles.

Take now the Swedish system of re-education and the system described by Dr. W. Colin MacKenzie in his well-known book, and test the claims made for each by their compliance or otherwise with the principles outlined above. Assume that one is dealing with the case of a deltoid muscle disabled by myelitis of related spinal neurosis. A Swedish expert would treat a muscle in such a condition by massage, later by passive movements, and as the power of voluntary contraction returns by active eccentric and concentric movements, that is, by "isolation" contraction-relaxation of the weak muscle. All movements are guided by the expert. This system of treatment is thus based on the assumption that the patient cannot control and voluntarily exercise and accurately load his own muscle without the manual aid of the "teacher." Now there is nothing in what is known of the mechanics, physiology or psychology of the action and re-education of muscles which justifies such *a priori* assumptions. Apart from theoretical considerations we have the demonstrated fact that a patient can, by his own unaided voluntary effort, control and exercise and accurately load a disabled muscle from the beginning of the recovery of function. Colin MacKenzie describes fully one method whereby this may be done, and others employing the same or similar methods have confirmed the results obtained by him.

The advantages of the natural method of "free" uncontrolled over a manually-controlled method of training are very great. First, the patient's interest in and attention for the skilled work of retraining his own muscle is easily aroused and maintained; the process is one of "re-education" in the true sense of the term. Further, the patient puts on the exercise load, guiding his output of effort by

his own feeling of power, or want of power, in carrying out the movements prescribed by his teacher, and the output of effort is checked by the fatigue induced by the exercise. Overloading and overwork are by these means avoided. Most important of all is the demonstration which we owe to Colin MacKenzie, that voluntary selective exercise of the muscle can be successfully carried out from the commencement of recovery of function of the "injured" anterior neurones—that is, in the hypothetical case we are considering. The rhythm of rest and exercise must, of course, be skilfully adapted to the functional condition of the muscle and postural rest must be maintained continuously between the intervals of selective exercise. Under the Swedish system exercise is not "voluntary" in any psychological sense of the term. The Swedish expert puts on the muscle load according to his (the expert's) estimate of the power, or want of power, of the muscle, and the fatigue limit of exercise may readily be passed.

By selective exercise is meant that the muscle undergoing training is made to do work as prime mover or as fixative muscle. This selective training with postural rest is continued until the muscle is capable of doing full postural and phasic work in free movement or fixation of the part. Space does not permit me to discuss the relation of reflex "unconscious" and automatic and voluntary associative re-education to the selective process I have been considering, or impediments to the re-educative processes.

No skill in re-education will recreate a completely atrophied spinal neurone. But there is every reason to believe that excessive postural and phasic exercise of the muscle may result in atrophy of recovering neurones and in elongation and atrophy of the muscle, with resulting dropped shoulder, wrist or foot, or other deformities and disabilities that are all too common late effects of the spinal anterior poliomyelitis. These results of unskilled re-education of function are mainly due to the failure to realize the cardinal importance of the principle of the submaximal exercise load and the great value of selective free voluntary exercise in the retraining of disabled muscles. I have employed, or seen employed, the Swedish method and the electrical-contraction method in large numbers of cases of muscular disabilities, and I owe to Dr. C. MacKay an introduction to the method of Colin MacKenzie. I have employed this latter method, modified as experience indicated, in cases of infantile paralysis and in a large number of cases of locomotor disability resulting from war wounds, and I have come to recognize the great value of the clinical research work of Colin MacKenzie. Is it too much to hope that we will soon hear the last of the Battle of the Schools—whether Swedish, German or another—and that all re-education experts will concentrate on scientific research into the many still obscure problems of re-education of function of neuro-muscular and muscular disabilities?—I am, etc.,

C. FORBES,

Late M.O. for Re-education of Muscles, Alder Hey
Military Hospital, Liverpool.

Aberdeen, Jan. 16th.

PATENT DUCTUS ARTERIOSUS.

SIR,—I read with interest in your issue of December 25th, 1920, Dr. Carey Coombs's account of four cases which lived to adult life; and, in your number of January 15th, Mr. Wilson Hall recalls three infantile cases.

The latter observer noted that no bruit could be heard in any of his cases, and in the only case I have seen I made a similar observation.

This was an infant in the first day of life. He cried lustily at birth, but within an hour became dyspnoeic and cyanosed, when I was called in by the midwife in attendance. The heart was beating forcibly, but no murmur was audible. All attempts at artificial respiration were fruitless, and at autopsy a wide patent ductus arteriosus was found connecting the left pulmonary artery with the commencement of the descending aorta.

A very interesting point in the case is that this was the third child the mother had lost in this way—namely, progressive dyspnoea and cyanosis, leading to a fatal termination; the first child lived two weeks, and the second three days. I was not in attendance on either occasion, and, unfortunately, no necropsies were performed, so that the diagnosis cannot be regarded as certain, but from her description I have no reason to doubt that a similar condition was present.

She has one living, healthy child, but this was by her first husband. A physical examination of her present husband revealed nothing which might throw a light on the mystery.—I am, etc.,

A. R. C. DOORLY, M.B., B.S. Lond.

Surbiton, Jan. 18th.

THE NAVAL MEDICAL SERVICE.

SIR,—I have seen no reply up to date to the letter of six aggrieved naval medical officers, dated December 1st, which appeared in your JOURNAL of December 11th. I quite agree with them in principle, but I would like to qualify two of their points. In the first place—"It is an undisputed fact that the great majority of newly qualified men who join the branch do so with no knowledge of the service." I agree with that, but the same thing applies to every other branch, and moreover, the medical student is often impressed with the idea that there is nothing to do in the navy, with a nice pension to look forward to after years of leisure. This attracts a class of man who is no use either in or out of the service. Such men after joining just sit down and grumble, and in the meantime neglect the opportunities which are at hand. In regard to "status" with the executive officer, a medical officer's status is just what he makes it; the status of the idler and grumbler is not high.

There are two sides to every question. What has the average naval surgeon done for the service? What is his status with the general medical profession? Without the British Medical Association at his back, how would he stand on his own merits? He has no grounds for comparing the Naval Medical Service with the Army Medical Service. The British Royal Army Medical Corps has made itself a pattern of efficiency to the rest of the world by hard work and by making a special study of the requirements of the service. They have justly earned any emoluments they have got. Contrast with the navy. Naval medical officers, with some exceptions, have not adapted themselves to their surroundings. They have not sufficiently considered the requirements of naval service. They have in turn compared their position with the army surgeon and the civil practitioner without realizing that the requirements of the navy are as special and as different from either as the work of the army surgeon is from the civil.

Granted that clinical material is lacking in the navy, interesting clinical material is not the stuff a navy is made of—nor a nation, for that matter; but surely the navy offers other fields of greater usefulness and of equal interest to a medical officer. Men in the navy are passed in as physically fit. It is our job, therefore, to keep them fit. A study of the diseases prevalent in the navy shows that they are, to a great extent, preventable, and yet what have we done in that direction? The subject is a life's study. Lind, Trotter and Blane, our illustrious predecessors of the last century, pointed out the way. Had we followed their example, the Naval Medical Service would not be in its present humble position; we should not have to look to other countries for information on the ventilation of ships; we should not have to grumble about recognition, about status, about pay, about honours, etc. We should have won everything on our merits. Every workman is worthy of his wage.

It is high time, therefore, that we put an end to grumbling and put our heads together to set about making the Naval Medical Service a worthy unit of the great service to which we belong. The rest will follow.—I am, etc.,

January 24th.

SURGEON COMMANDER, R.N.

Universities and Colleges.

UNIVERSITY OF OXFORD.

Lectures in Clinical Medicine and Surgery.

THE Regius Professor of Medicine, Sir Archibald E. Garrod, K.C.M.G., is conducting a course of clinical lectures on Tuesdays, at 2.30 p.m., at the Radcliffe Infirmary. Courses of clinical lectures are also being given by the Litchfield Lecturer in Medicine, Dr. W. Collier, and by the Litchfield Lecturer in Surgery, Mr. A. P. Dodds-Parker, F.R.C.S.

Scholarships in Natural Science.

An examination for scholarships in natural science is announced at Merton, Exeter, New, Brasenose, and Corpus Christi Colleges, beginning on June 28th.

At Jesus College the following elections to exhibitions in natural science are announced: G. M. Dyson, C. Hutton, K. P. Osborne, M. H. Evans, W. G. Rees, H. W. Jones.

At a congregation held on January 20th the degree of Bachelor of Medicine was conferred on T. S. Nelson and H. G. Burford.

UNIVERSITY OF CAMBRIDGE.

At a congregation held on January 21st the following medical degrees were conferred:

M.B., B.CH.—R. C. P. Whitecombe, D. W. R. Richardson, W. S. Sykes.
B.CH.—J. M. Lawrie, J. L. Potts, F. S. Maclean, F. G. Wood, G. P. N. Richardson.

UNIVERSITY OF LONDON.

LONDON HOSPITAL.

THE Liddle Triennial Prize, in the gift of the London Hospital, has been awarded to Surgeon Commander S. F. Dudley, O.B.E., M.D., R.N., and Professor James McIntosh, M.D.

UNIVERSITY OF EDINBURGH.

A MEETING of the University Court was held on January 17th. Professor Lorrain Smith, Dean of the Faculty of Medicine, was elected one of the delegates to a Congress of the Universities of the Empire to be held in London and Oxford in July. Dr. J. Stewart Fowler, a senior lecturer in the Faculty of Medicine, was appointed a member of the Faculty. It was agreed to revive the course on advanced morphology of the vertebrata, which had been suspended since 1914. Dr. Henry Yellowlees and Dr. William McAllister were appointed university assistants to the Professor of Psychiatry.

Dr. H. D. Wright, of the Department of Pathology, has tendered his resignation on appointment as assistant to the Superintendent of the Laboratory of the Royal College of Physicians. Professor Kynoch has been appointed joint representative of the University Courts of the Universities of St. Andrews and Edinburgh on the Central Midwives Board for Scotland.

UNIVERSITY OF MANCHESTER.

PROFESSOR SIR WILLIAM THORBURN has resigned the Chair of Clinical Surgery, and at the last meeting of the Council and Senate the following resolution was passed:

That the Council and Senate have heard with deep regret of the resignation by Sir William Thorburn, C.B., K.B.E., M.D., F.R.C.S., of his position as senior honorary surgeon to the Manchester Royal Infirmary, which involves also his resignation of the Chair of Clinical Surgery in the University. The Council and Senate desire to express to Sir William Thorburn their high appreciation of the great services which he has rendered to the university during his long connexion with it as a teacher; of the contributions he has made to the advancement of knowledge in surgery, and of his distinguished record and skill in the practice of his profession. The regret which Sir William Thorburn's friends and colleagues feel at the termination of his official connexion with them is increased as they recall the high qualities and devotion which he has brought to the administrative side of his university work, and the gentility and consideration which he has always shown towards his colleagues.

The University Prize in Medicine has been awarded to L. J. Witts.

Dr. A. H. Holmes and Mr. Geoffrey Jefferson, M.S., F.R.C.S., have been appointed lecturers in applied anatomy.

ROYAL COLLEGE OF SURGEONS OF ENGLAND.

HUNTERIAN LECTURES.

THE following arrangements are announced for the forthcoming Hunterian Lectures to be delivered in the theatre of the college, Lincoln's Inn Fields, at 5 p.m.: Mr. W. Sampson Handley will give one lecture on the pathology and surgery of lupus on Monday next, January 31st; Mr. W. G. Howarth will give one lecture on mucocele and pyocoele of the nasal accessory sinuses on Wednesday, February 2nd; Mr. C. W. Gordon Bryan will give one lecture on injuries of the diaphragm, with special reference to wounds jointly involving thoracic and abdominal viscera, on Friday, February 4th.

LONDON INTERCOLLEGIATE SCHOLARSHIPS.

THE London Intercollegiate Scholarships Board announce that twenty-three scholarships and exhibitions of an aggregate value of about £2,450, open to men and women, and tenable in the Faculties of Arts, Science, Medical Sciences, and Engineering of University College, King's College, East London College, and Bedford College, will be offered for competition on May 3rd next.

Seventeen medical entrance scholarships and exhibitions, of an aggregate value of about £1,530, tenable in the Faculty of Medical Sciences of University College and King's College, and in the Medical Schools of Westminster Hospital, King's College Hospital, University College Hospital, the London (Royal Free Hospital) School of Medicine for Women, and the London Hospital, will be offered for competition on June 28th.

Full particulars and entry forms may be obtained from the Secretary of the Board, S. C. Ranner, M.A., The Medical School, King's College Hospital, Denmark Hill, London, S.E.5.

Obituary.

DAVID YELLOWLEES, M.D. EDIN., LL.D. GLASG.,
Late Physician-Superintendent, Royal Glasgow Asylum.

THE death took place, at Edinburgh, in his eighty-fifth year, of Dr. David Yellowlees, formerly physician-superintendent of the Royal Glasgow Asylum, Gartnavel. Dr. Yellowlees was a native of Stirling, where he received his early education, and he proceeded to Edinburgh University, graduating M.D. in 1857. After an appointment as house-surgeon at Edinburgh Royal Infirmary and a period of study in Paris he became assistant to Sir William Gairdner, physician to the Edinburgh Royal Infirmary. Later he was appointed assistant physician at the Royal Edinburgh Asylum, Morningside, remaining there until 1863. In that year he became superintendent of the Glamorgan County Asylum, where he remained twelve years, building up a reputation as an administrator and physician of distinction.

In 1875 Dr. Yellowlees was appointed physician-superintendent of the Royal Glasgow Asylum, Gartnavel, a post which he held till his retirement in 1902. Under his administration this institution grew and flourished, and Dr. Yellowlees became well known throughout Scotland as a consultant in mental diseases. He was lecturer on insanity at Glasgow University; president of the Psychological Section of the British Medical Association at the Glasgow Meeting in 1885; and president of the Faculty of Physicians and Surgeons of Glasgow during 1892-94. In 1888 he received the degree of LL.D. from the University of Glasgow. In addition to the many marks of recognition he received in this country, he was elected an honorary member of the American Medico-Psychological Association, of the Moscow Society of Neurological and Mental Diseases, and of other foreign societies. Dr. Yellowlees took a leading part in the philanthropic life of Glasgow; since 1910 he had been chairman of the Broomhill Home for Incurables; he was one of the founders of the Glasgow Association for the Care of Defective and Feeble-minded Children; he was active in the inauguration of the Lanfine Home for Advanced Cases of Consumption; and he took a warm interest in many other branches of public work. He was highly esteemed for his strong common sense and his high sense of duty by all who knew him in connexion with public affairs, while his deep religious convictions moulded and coloured his whole life.

After his retirement Dr. Yellowlees continued to live in Glasgow until the autumn of 1919, when he removed to Edinburgh. He is survived by his wife, his daughter, and two sons, one of whom is Dr. David Yellowlees of Stirling, and the other Dr. Henry Yellowlees, senior assistant physician at the Royal Edinburgh Asylum, Morningside.

RUPERT FARRANT, M.C., F.R.C.S. ENG.,
Late Assistant Surgeon, Westminster Hospital.

MR. RUPERT FARRANT, whose untimely death last week, at the age of 36, came as a shock to his many friends, was a man of singularly winning personality and great ability. He was educated at the Westminster Hospital, and studied also at King's College and St. Bartholomew's. After qualifying M.R.C.S. and L.R.C.P. in 1906, he held a good many resident posts at his own and other hospitals, eventually becoming Surgical Registrar at Westminster. He obtained the Fellowship of the Royal College of Surgeons in 1909. He was specially interested in the ductless glands, and did a great deal of research work on thyroid function in health and disease, in the laboratory of Professor Cushny at University College and elsewhere. His assiduity in the collection and examination of thyroids from cases of disease of all kinds from asylums, infirmaries, and hospitals, was remarkable. He formulated a theory of a correlated cycle of changes in the histological appearances and functional activity of the gland under the influence of toxins, and was particularly interested in the relation between deficient thyroid action and some forms of insanity.

Rupert Farrant saw active service throughout the war at Gallipoli, in Egypt, Mesopotamia, and in France, where he gained the Military Cross. He suffered severely from trench fever and was seriously injured by a shell explosion. While still in France he was elected to the honorary staff

of the Westminster Hospital, and took over his duties as soon as he was demobilized. His health was, however, much impaired, and though the renal trouble left by the trench fever got better, he never recovered completely from the shell concussion. Feeling himself unable to carry out his duties as he would have liked, he resigned his appointment some months ago, and had been resting in the country up till the last.

ARTHUR JACKSON, F.R.C.S. ENG.,
Shrewsbury.

WE regret to announce the death, on January 9th at Shrewsbury, of Mr. Arthur Jackson.

Born at Grays, Essex, in 1855, son of the late Daniel Jackson, of Chadwell Place, Grays, he was educated at Brentwood, whence he proceeded to St. Bartholomew's. He qualified in 1878 and became F.R.C.S. Eng. in 1882. After holding resident appointments at St. Luke's Hospital, London, and at Beckett Hospital, Barnsley, he went to Shrewsbury, where in 1884 he joined the late Mr. J. H. Humphreys, then senior surgeon at the Salop Infirmary; in partnership. He was appointed surgeon to the Salop Infirmary in 1890, the other surgeons being H. J. Rope, who died twenty years ago, and Mr. W. Eddowes, now living in retirement at Bath. Those were difficult days in the hospital surgical world, when the Listerian system of wound treatment was only being tardily recognized, and Mr. Jackson, as an ardent supporter of the new principles, had much hard work to accomplish. He also witnessed, as the result of the new surgery, the invasion of many new areas of work, and was a keen disciple of such men as Mayo, Horsley, Freyer, and Moyihan. A bold and resourceful surgeon, Mr. Jackson soon acquired a very large consulting practice in Shropshire and the adjoining counties of Mid Wales, where his energy and quiet determined manner made him always the friend in need of his country brethren.

He was surgeon also to the Newtown Infirmary, Montgomeryshire, and to the Wenlock and Brosely Hospitals in Shropshire, and to the Bicton Asylum and the Tuberculosis Sanatorium at Shirleet. Notwithstanding these hospital appointments with their many urgent calls, it was often remarked that he always seemed to have time to attend to the individual matter in request, and that he never refused help nor seemed to be hurried—no one ever applied to him in vain. He was for many years a great supporter of the British Medical Association. He was president of the local Branch in 1899, when he read a paper on "Diseases of the breast," which contained much closely reasoned observation and carefully deduced indications for treatment.

During the war stress of work fell heavily upon Mr. Jackson. He was due to retire from his arduous duties as senior surgeon to the Royal Salop Infirmary in 1915, but at the request of his colleagues he willingly consented to remain at his post, and only vacated it in November, 1919. Early in December last he had received by telegram the sad news of the sudden death in India of his only son, Arthur H. Conway Jackson, I.C.S. He was thus, stricken with grief, little able to withstand the onset in the first week of the new year of an attack of influenza of a virulent nature, complicated by double pneumonia.

He married Florence Eleanor, youngest daughter of the late Rev. S. Sunderland, Vicar of Penistone, Yorkshire, by whom, together with a daughter, he is survived. A memorial service was held at St. Chad's Church, Shrewsbury, on January 12th, which was very largely attended by his professional brethren from far and near, and he was afterwards laid to rest in the general cemetery, in a certain part where lie several of his former fellow-workers.

Many readers will be grieved to hear of the death of Dr. EDWARD COLLINS BOUSFIELD, which took place suddenly on January 7th, from the rupture of an unsuspected aneurysm. He had had several serious illnesses in recent years, some of them contracted in the pursuit of his pathological duties. He devoted the times of convalescence to sea voyages, and in this way he visited the East and West Indies and Africa. He returned from his last voyage in good health, and we were hoping for years more of fruitful work. He studied at St. Bartholomew's Hospital, and qualified L.R.C.P., M.R.C.S., in 1878. He spent a number

of years in general practice in the Old Kent Road, doing a good deal of research work at the same time. He was an early authority on photomicrography, and wrote a useful manual upon the subject. On his appointment to the position of bacteriologist to the metropolitan boroughs of Camberwell and Hackney and director of the Camberwell Research Laboratories he went to reside at Denmark Hill, where he remained to the end. He leaves a widow and three sons and a daughter. The youngest son is also in the medical profession, and is, we understand, carrying on with the old staff his father's work at Camberwell. Dr. Bousfield had a striking personality, and all who knew him set a high value on his friendship. He was a keen investigator, having an alert mind, a well balanced judgement, a thirst for truth, and a special aptitude for the practical application of new knowledge.

The Services.

HONOURS.

MENTIONS IN DISPATCHES.

THE names of the following officers have been brought to the notice of the Secretary of State for War by Lieut.-General Sir J. A. L. Haldane, General Officer Commanding-in-Chief, Mesopotamian Expeditionary Force, for distinguished and gallant services and devotion to duty, and are recommended for special recognition:—Captains: W. Adams, R.A.M.C.(S.R.), L. G. Blackmore, R.A.M.C.; R. R. Thun Oo Tha, I.M.S.; Sub-assistant Surgeons: Abdulmia Ahmedia Bnkhari and Hashim Ali Khan, I.M.D.

DEATHS IN THE SERVICES.

Major James Sydney Pascoe, D.S.O., R.A.M.C., died in the Military Hospital at Poona on December 29th, aged 43. He was the fourth son of the Rev. S. Pascoe of Newquay, was educated at Charing Cross Hospital, and took the M.R.C.S. and L.R.C.P.Lond., in 1904. After holding a house-surgeoncy at Charing Cross, he entered the army as lieutenant in 1905, and attained the rank of major on October 15th, 1915. He served in the South African war in 1900-01, as a combatant, in the Imperial Yeomanry, taking part in the operations in the Orange Free State and in the Transvaal, including the action at Wittebergen, and gained the Queen's medal with four clasps. In the late war he was twice mentioned in dispatches, in the *London Gazette* of May 29th, 1917, and for the Indian frontier campaign on July 10th, 1919, received the 1914 star, with the war medal and Victory medal, the D.S.O. on June 3rd, 1917, and the Legion of Honour (Chevalier) on February 24th, 1918.

COMMITTEE ON POST-GRADUATE MEDICAL EDUCATION IN LONDON.

As we go to press the composition is announced of the Committee appointed by the Minister of Health, with the concurrence of the University Grants Committee, to formulate a scheme for post-graduate instruction in medicine in London.

The terms of reference are: "To investigate the needs of medical practitioners and other graduates for further education in medicine in London, and to submit proposals for a practicable scheme for meeting them."

The Chairman, as stated in the *JOURNAL* this week, at page 170, is the Earl of Athlone, G.C.B. The other members of the Committee are Dr. H. J. Cardale, Chairman of the London Panel Committee; Sir Wilmot Herringham, K.C.M.G., M.D., a member of the University Grants Committee; Sir George Makins, G.C.M.G., late President of the Royal College of Surgeons of England; Sir George Newman, K.C.B., M.D., Chief Medical Officer, Ministry of Health and Board of Education; Sir Robert Newman, Bt., M.P. for Exeter; Sir Edward Penton, K.B.E., a member of the board of the Middlesex Hospital; Sir E. Cooper Perry, M.D., Principal Officer of the University of London; Mr. J. Dill Russell, F.R.C.S., late honorary secretary of the Hampstead Division of the British Medical Association; and Dr. T. W. Shore, Dean of St. Bartholomew's Hospital Medical School. The secretary is Mr. A. L. Hetherington, to whom all communications should be addressed at the Ministry of Health, Whitehall, S.W.

DR. JOSEPH CATES, M.O.H. for the county borough of St. Helens, has been appointed county M.O.H. for Surrey.

DR. G. S. TRAIL, on the occasion of his retirement after forty-three and a half years' active practice at Strichen, Aberdeenshire, has been presented with an inscribed silver salver, a gold watch chain, and a cheque for £130 by the inhabitants of the district.

VITAL STATISTICS FOR ENGLAND AND WALES, 1920.

WE are indebted to the Registrar-General for the following statement showing the birth rates and death rates and the rates of infantile mortality in England and Wales and in certain parts of the country during 1920.

ENGLAND AND WALES.

Birth Rate, Death Rate, and Infant Mortality during the Year 1920 (Provisional Figures).

	Birth Rate per 1,000 Total Population.	Death Rate per 1,000 Population (Crude Rate).	Deaths Under One Year per 1,000 Births.
England and Wales	25.4	12.4	80
96 great towns, including London (populations exceeding 50,000 at the Census of 1911)	26.2	12.5	85
148 smaller towns (populations from 20,000 to 50,000 at the Census of 1911)	24.9	11.3	80
London	26.3	12.4	75

The death rate for England and Wales relates to the whole population, but that for London and the groups of towns to the civilian population only.

The rates here shown are provisional, but any adjustment that may be found necessary will not affect the following points, namely: (1) That the birth rate for 1920 is the highest of the decade; (2) that the death rate is the lowest ever recorded; (3) that the infant mortality is the lowest ever recorded; (4) that the number of births is the highest ever recorded; (5) that the number of deaths is the lowest recorded since 1862, when the population was only 20 millions.

Medical News.

THE Ministry of Health has issued an amended notice with regard to substitutes for salvarsan which local authorities may supply to practitioners and the prices that may be paid. The names of the substances are: Arsenobillon and novarsenobillon (Messrs. May and Baker), diarsenol and neodiarsenol (Messrs. Allen and Hanburys), dialyl (The Anglo-French Drug Company), kharsivan and neokharsivan (Messrs. Burroughs, Wellcome and Co.), and salvarsan (Messrs. Evans, Sons, Lescher and Webb).

PROFESSOR H. R. KENWOOD, C.M.G., will give an introductory lecture on Monday, January 31st, at 5.30 p.m., to students attending the courses of instruction at the Royal Sanitary Institute.

THE annual dinner of past and present students of the Royal London Ophthalmic Hospital will be held at the Café Royal, Regent Street, on Thursday, February 10th, at 7 for 7.30 o'clock. The chair will be taken by Mr. J. B. Lawford, Consulting Surgeon to the Hospital. Tickets, price 15s. (excluding wine), may be obtained from Mr. Charles Golden, 42, Welbeck Street, W.1.

A SERIES of six post-graduate lectures and demonstrations in connexion with the Manchester Babies' Hospital will be held on Saturdays at 3.30 p.m., commencing February 5th. There is no fee for attendance.

THE annual dance of the Medical Society, University College Hospital, will be held in the Medical School Library on Monday, February 7th, from 9.30 to 2.30. Tickets, 15s., may be had from Mr. W. L. Spencer-Cox, honorary secretary, at the hospital.

DR. GEOFFREY EVANS has been appointed Assistant Director of the Medical Professorial Unit at St. Bartholomew's Hospital, and Assistant Physician to the Hospital. This appointment completes the staff of the unit, Dr. Francis Fraser having already succeeded Sir Archibald Garrod in the post of Director.

A SPECIAL meeting of the Council of King Edward's Hospital Fund for London was held on January 26th to consider the policy to be recommended to the Government for the preservation of the voluntary system of hospital management and control. The specific resolutions contained in a report of the Executive Committee were unanimously adopted, and ordered to be forwarded to the Prime Minister, the Minister of Health, and the members of the Government Committee of Inquiry into Hospital Finance.

Letters, Notes, and Answers.

As, owing to printing difficulties, the JOURNAL must be sent to press earlier than hitherto, it is essential that communications intended for the current issue should be received by the first post on Tuesday, and lengthy documents on Monday.

ORIGINAL ARTICLES and LETTERS forwarded for publication are understood to be offered to the BRITISH MEDICAL JOURNAL alone unless the contrary be stated.

CORRESPONDENTS who wish notice to be taken of their communications should authenticate them with their names—of course not necessarily for publication.

AUTHORS desiring reprints of their articles published in the BRITISH MEDICAL JOURNAL are requested to communicate with the Office, 429, Strand, W.C.2, on receipt of proof.

In order to avoid delay, it is particularly requested that ALL letters on the editorial business of the JOURNAL be addressed to the Editor at the Office of the JOURNAL.

The postal address of the BRITISH MEDICAL ASSOCIATION and BRITISH MEDICAL JOURNAL is 429, Strand, London, W.C.2. The telegraphic addresses are:

1. EDITOR OF THE BRITISH MEDICAL JOURNAL, *Aitiology*, Westrand, London; telephone, 2630, Gerrard.

2. FINANCIAL SECRETARY AND BUSINESS MANAGER (Advertisements, etc.), *Articulate*, Westrand, London; telephone, 2630, Gerrard.

3. MEDICAL SECRETARY, *Medisecra*, Westrand, London; telephone, 2630, Gerrard. The address of the Irish Office of the British Medical Association is 16, South Frederick Street, Dublin (telegrams: *Bacillus*, Dublin; telephone, 4737, Dublin), and of the Scottish Office, 6, Rutland Square, Edinburgh (telegrams: *Associate*, Edinburgh; telephone, 4361, Central).

QUERIES AND ANSWERS.

INCITAMIN OR FISCHER'S SOLUTION.

A CORRESPONDENT asks whether incitamin, an organic preparation devised by Professor Fischer of Copenhagen, is to be obtained in this country.

An article, in which Professor J. F. Fischer, an x-ray specialist in Copenhagen, described his solution, to which he has given the name "incitamin," although it is also known as Fischer's solution, was published in the *Ugeskrift for Læger*, the journal of the Danish Medical Association, on December 2nd, 1920. According to this article the solution contains carbolic acid, serum and saliva (both in a modified form), and extract of pancreatic gland. Professor Fischer states that these ingredients are obtained from calves and horses, that the solution is colourless or faintly yellow and slightly cloudy, and that a deposit which formed on standing did not indicate any diminution in its potency. He tested its stability by keeping it for some time in a thermostat, and he has convinced himself that it is not toxic, provided it is properly applied. Originally he intended to continue his investigations of this preparation in modest obscurity, but he has changed his mind and put the preparation on the market, because he considered the final stage of its evolution had been reached, and that it was desirable that it should be manufactured under adequate supervision and on a large scale in order that it might be available to many investigators. It is prepared by the "Serpens" company, and is now obtainable from chemists in Denmark, but Professor Fischer does not mention the price. Much of his paper is concerned with clinical reports of hospital cases in which incitamin was used as a dressing for wounds and ulcers. In one of these cases a large ulcerating cancer of the back of the hand was treated, first with radium and then with x rays; the new growth was replaced by deep and extensive ulceration, which seemed an even more pressing indication for amputation than the original condition; the report of the case goes on to relate the triumph of incitamin. Almost equally dramatic are other records, several of which are of cases of varicose ulcer. The lay press in Denmark seized on this publication, hailing incitamin as the dawn of a new era, and so on. The incident drew from Dr. J. S. Møller a protest (*Ugeskrift for Læger*, December 16th) under the heading "A New Arkanum." He writes: "Professor Fischer cannot have wholly forgotten that throughout the past years there has been waged a constant war through *Ugeskrift for Læger* against secret remedies, a war, the provisional fruits of which are to be found in recent legislation . . . He must not, therefore, be surprised if one who has taken part in this war squirms when he reads the last number of *Ugeskrift* and the howl of advertisement which has gone up from the press." The same number of *Ugeskrift* contains a reply by Professor Fischer and a rather halting defence of the policy of the journal by the editors. No one familiar with conditions in Denmark and the high esteem in which the editors of *Ugeskrift* are held by their

colleagues will question the motives by which they have been actuated in this matter, but it cannot be denied that the position brought about is unfortunate. The medical profession in this country may well await fuller and more precise information before using the solution.

BRaille TYPE FOR BLIND CHILDREN.

DR. ROBERT A. WELSH of Felton has under his care a child, aged 8, with an acquired hydrocephalus, first noticed at the age of 2 years. Five years ago, after a series of convulsions, the sight was lost. There is now a spastic condition of the legs, with great wasting, though the child can walk a little if helped. She is bright and intelligent, and can easily learn poetry and repeats what is read to her. Dr. Welsh asks whether it would be possible to teach the child to read by the Braille system, and, if so, the best age to begin.

We have referred this question to Dr. J. Lloyd Johnstone, Librarian to the National Institute for the Blind (224, Great Portland Street, W.1), who writes: "There is no reason why the patient should not, at once, commence to learn to educate the sense of touch in the fingers. As she appears to be an intelligent child she should soon be in a position to take up Braille. Children are instructed to read Braille at as early an age as letter press. At the outset the sense of touch is educated by the use of small beads, and after the child has learned the 'feel' of these under the finger-tips, it is taught the Braille characters in large embossed type. All information as to books and apparatus may be obtained by writing to the Secretary-General, National Institute for the Blind, 224, Great Portland Street, W.1."

BLOOD CHANGES IN T.N.T. POISONING.

"W. B." asks for references to the literature dealing in detail with the symptoms and course of the anaemia caused by trinitrotoluene poisoning during the war. He especially wishes for records of the blood picture, marrow examination, and the subjective symptoms.

The symptoms and signs of poisoning by trinitrotoluene and other substances used in the manufacture of munitions are described in Dr. W. H. Wilcox's Lettsomian lectures on jaundice, 1919, given before the Medical Society of London, and published in full in the BRITISH MEDICAL JOURNAL in 1919. Dr. Wilcox has kindly added the following information: With regard to the blood changes in T.N.T. poisoning, a severe anaemia of pernicious type occurs in some cases, and this may be due to a combination of poisoning by T.N.T., and to bacteriological toxæmia from associated streptococcal infection from the mouth or intestine, the primary cause being the T.N.T. poisoning. The blood changes in T.N.T. poisoning were studied by Captain M. J. Stewart, R.A.M.C., and published in the *Proceedings of the Royal Society of Medicine*, January 23rd, 1917 (Discussion on Toxic Jaundice in Munition Workers), and also in the *Lancet*, January 27th, 1917. The symptoms and signs of cases of progressive anaemia following T.N.T. poisoning are similar to those of pernicious anaemia, and the treatment should be on the lines adopted for such cases.

DILATED PUPILS.

"C. F. R." writes: Miss B., aged 20, is a healthy girl of nervous energetic temperament. About ten years ago the right pupil, for no apparent cause, became widely dilated and has remained so. Two years ago the left pupil followed suit. Both pupils are now widely dilated—the left one being rather the larger. There is very slight reaction to an intensely bright light. There are no other physical signs. No enlarged glands are shown by x rays, and the blood is negative to Wassermann. With suitable glasses she can read for about half an hour, after which eye-strain causes severe headache. She has been seen by three consultants, who can throw no light on the cause or suggest treatment, though two of them—one a neurologist and the other an ophthalmic surgeon—have seen two similar cases, treatment being unsatisfactory. Any suggestion regarding cause or treatment would be gratefully received, as the girl is hopelessly handicapped by her condition and has been obliged to give up a university career.

INCOME TAX.

"TERRITORIAL" was called up in August, 1914, and served until December, 1918. In the spring of 1917 and 1918 he handed in to the local surveyor of taxes statements of such small amounts as were earned by colleagues on his behalf, and on each occasion was told that he would not be assessed as he was on active service. In July last he was asked to supply particulars of civilian earnings, and has now been called upon to pay £52 4s. tax thereon. He asks whether he has any redress.

Our correspondent seems to have legitimate ground for complaint in being told that he was not taxable and subsequently taxed; but we fear that the question will have to be

settled on the basis as to whether or not the charge is legal. On that ground he appears to have no redress, because such income as might accrue to him as a result of his civil practice is undoubtedly chargeable—on the basis of the amount receivable for each year of assessment. It might, perhaps, be worth while to ask for full particulars of the assessments made (unless they have already been supplied) and to make sure that all proper allowances have been made. We assume that for 1920-21 "Territorial" is assessed at the average amount of his civilian earnings in the years 1917, 1918 and 1919, and not, for instance, on the amount of his earnings for the first post-war year.

"E. A. Y." writes: Last January I bought a large practice (death vacancy) and was afterwards told that I must pay income tax on the three years' average earnings of my (deceased) predecessor. Is this the law, and how am I to find out this average?

* * That is the law subject to this proviso, that if the successor can prove at the end of the year that the profits have fallen short of the sum assessed through some *specific* cause, then the average figure can be displaced by the earnings of the year. Such earnings would have to be calculated not on the usual cash basis but on the value of the professional bookings. Our correspondent's only method of arriving at the average would seem to be from an examination of the books of the predecessor, though possibly the local inspector of taxes may have been supplied with some information as to the first two of those three years.

LETTERS, NOTES, ETC.

SURGERY OF THE ELBOW.

MR. R. ATKINSON STONEY, F.R.C.S.I., desires to make two corrections in the report which was sent to us of the discussion on the modern surgery of the elbow in the Surgical Section of the Royal Academy of Medicine in Ireland (January 8th, 1921, p. 48). The official reporter made Mr. Stoney say: "Before the war an ankylosed elbow was looked upon as a success, and excision for it was banned." The correct reading should be, "Before the war excision of the elbow for ankylosis was considered a successful operation, and an ankylosed elbow was considered a surgical failure; but now an ankylosed elbow is looked upon as a success, and excision for it is banned." In the reference, a few lines further down, to primary excision the words "employed by the inexperienced" should be omitted.

IMPROVED MOUTH GAGS.

DR. HARDING H. TOMKINS (Ealing) writes with reference to the mouth gag described by Major Black on January 22nd, p. 127: In 1884 I invented a gag upon much the same principle, so far as the non-cutting knife edge tooth plates go. My gag, however, was concave behind the knife edge. It was made for tube-feeding refractory lunatics, and could be introduced behind the molars; and I remember finding it of great value in the case of a man under anaesthesia whose mouth was spasmodically closed so that one could not get at his tongue. With this gag I was able to open his mouth, and, incidentally, to depress his tongue at the same time. The gag was made for me by Messrs. Maw, Son, and Thompson.

ANGIO-NEUROTIC OEDEMA.

DR. A. BERNHARD-SMITH (London, S.W.) writes: Some further account of the case of wandering or angio-neurotic oedema which I published (with a photograph of the patient) in the BRITISH MEDICAL JOURNAL of June 8th, 1901, may be of interest. The father was somewhat gouty, to my knowledge; but neither the patient nor his brother and three sisters have shown signs of gout. There is no history of epilepsy in the family. Some years ago one sister had a single, severe attack of angio-neurotic oedema following dysentery (see a somewhat similar case reported by E. W. G. Masterman, F.R.C.S., BRITISH MEDICAL JOURNAL, April 3rd, 1897; but my patient's oedema, which during 1895-98 was treated with arsenic, iodides and ointments, and special dieting, although no hypodermic injections of serum were given, seems to have worn itself out, as he has not since had a return of the trouble.

TAPEWORM.

DR. J. REID (London, W.C.) writes: Dr. Low's case and treatment in the BRITISH MEDICAL JOURNAL of January 22nd may excuse me for recording an experience. A lad of about 15, a worker on the land, had snuffed and been treated without effect for about a year. I gave him a mixture containing 2 drachms of the liquid extract of male fern with an emulsion of castor oil and tragacanth in a 6 oz. bottle, one-twelfth part every four hours. The worm was brought to me, with its head, in a few days. My rationale depended on a desire to keep the worm constantly fed with the filix mas. Filicic acid or isobutyryloxy-naphtho-quinone is not to be given with castor oil on account of its poisonous qualities (Squire). Like

dillenic acid, from *Hibbertia volubilis*, which kills the earth-worm after a convulsion, it is insoluble in water and soluble in alkali, hence probably it becomes efficient as a vermicide.

DANGEROUS DRUGS ACT.

MR. A. E. CLEAR, pharmacist of Uckfield, in the course of a letter on this subject expresses the opinion that at the present time anyone can obtain the most dangerous poisons with little or no difficulty, whether for felonious purposes or not. Self-medication, he states, particularly amongst women, is alarmingly on the increase. Not so many years ago the number of drugs which found their way into domestic use were few, and consisted of such harmless things as Pil Rhei Co., Conf. Sennae, Mag. Sulph. But to-day custom has changed. The public seem to have become familiar with the latest drugs, without, of course, understanding their therapeutical properties. I think, he says, the popularity of the tablet has much to do with it; I have found amongst many people a belief that if a drug is in tablet form it must be harmless. When the Dangerous Drugs Act becomes operative, it will not, Mr. Clear thinks, be effectual in the purpose for which it is intended unless effective measures are introduced to make it so, any more than the Pharmacy Acts of 1868 and other dates have prevented poisonings from taking place. Any law must, to be effective, be provided with the means to carry it out, and therein lies the crux of the whole thing. I do not of course suggest, he continues, that the Pharmaceutical Society is incapable of carrying out whatever new regulations may be made, but the fact remains that in the past regulations with regard to the sale of poisons have been most ineffective. In spite of the regulations being plain and concise—on paper—it has been left, in many ways, to the individual shopkeeper to interpret them according to his individual discretion, and while many—I am glad to think, the majority—have acted conscientiously and well, there are others who practically ignore every restriction that is put upon them, and those the Pharmaceutical Society certainly does not appear to have reached. In general the chemist in small country towns and the back streets of Suburbia is the worst offender, because, knowing his customers personally, he is pretty safe from interference.

THE Food Education Society has issued its report for the past year. A copy of this, together with a list of publications and particulars of lectures and cookery demonstrations, may be obtained for 7d., post free, from the society (Danes Inn House, 265, Strand, W.C.2).

A PLEASANT little adjunct to the treatment of the neurotic child is the "Sleepy Dustman" lamp and night-shade, designed by the wife of a medical man. She tells us it has been of great service in helping to calm the bedtime terrors of nervous children, who cannot bear to be left alone in the dark. It is now made by the Artistic Shade Company, 146, Kensington High Street, W.8, and there is a little story book with verses and appropriate music to reinforce the suggestion of the lamp-shade.

VACANCIES.

NOTIFICATIONS of offices vacant in universities, medical colleges, and of vacant resident and other appointments at hospitals, will be found at pages 31, 34, 35, 36, and 37 of our advertisement columns, and advertisements as to partnerships, assistantships, and locum tenencies at pages 32 and 33.

THE following appointments of certifying factory surgeons are vacant: Bridge of Weir and Kilmacoll (Renfrew), Portadown (Armagh), Strichen (Aberdeen).

A VACANCY is announced for an ophthalmic specialist medical referee under the Workmen's Compensation Act, 1906, for County Court Circuit No. 4, comprising the Bacup and Rawtenstall, Blackburn and Darwen, Blackpool and Fleetwood, Clitheroe, Garstang, Haslingden and Accrington, Kirkham, Preston and Chorley, and Lancaster County Courts. Applications should be addressed to the Private Secretary, Home Office, by February 16th.

SCALE OF CHARGES FOR ADVERTISEMENTS IN THE BRITISH MEDICAL JOURNAL.

	£	s.	d.
Six lines and under ...	0	9	0
Each additional line...	0	1	6
Whole single column (three columns to page)	7	10	0
Half single column ...	3	15	0
Half page ...	10	0	0
Whole page ...	20	0	0

An average line contains six words.

All remittances by Post Office Orders must be made payable to the British Medical Association at the General Post Office, London. No responsibility will be accepted for any such remittance not so safeguarded.

Advertisements should be delivered, addressed to the Manager, 429, Strand, London, not later than the first post on Tuesday morning preceding publication, and, if not paid for at the time, should be accompanied by a reference.

NOTE.—It is against the rules of the Post Office to receive *post-restante* letters addressed either in initials or numbers.

The Cameron Lecture

ON

THE NECESSITY OF ORTHOPAEDIC TRAINING :

ITS RELATION TO THE PREVENTION AND CURE OF DEFORMITIES.

DELIVERED AT THE UNIVERSITY OF EDINBURGH ON JANUARY 14TH, 1921.

BY

SIR ROBERT JONES, K.B.E., C.B., M.Ch.,

F.R.C.S. ENG., IREL., AND EDIN.,

LECTURER ON ORTHOPAEDIC SURGERY, LIVERPOOL UNIVERSITY;
DIRECTOR OF ORTHOPAEDICS, ST. THOMAS'S HOSPITAL, LONDON.

ONE of the greatest of all honours that a surgeon can receive is the Cameron prize from the University of Edinburgh. It is needless to say how deeply grateful I am to have been selected by your university, and when I think of the distinguished men from various countries who have been recipients in years gone by, I am only too painfully conscious of my unworthiness. Were it not for the tragic incidence of war and the opportunity given me to organize schemes of physical reconstruction the prize must needs have fallen into better hands. It is because it bears relation in this instance to war work that I venture to give you a very simple address relating to the cripple problem generally, both infant and adult, pointing out some of the lessons which the war has taught us—more especially in relation to segregation and the prevention of deformity, emphasizing the necessity of paying more attention to the education of students in orthopaedic principles if they are to be efficiently equipped in after-life. The prevention of surgical tragedies is largely dependent upon the general practitioner, and his usefulness is largely dependent upon his academic training. He frequently sees the beginning of diseases when he enters practice—a phase of work which he has hitherto only studied theoretically—for his hospital experiences have been largely concerned with more advanced stages. He fills an extremely responsible position in most departments of his work, and this is especially true in regard to the early advent of deformities. These deformities are mainly associated with tuberculosis, rickets, and infantile paralysis, but then there are others of congenital origin.

It is evident that many of the deformities due to these conditions may be altogether prevented, and that practically all of them may be so corrected as to enable the patient to become ultimately a valuable industrial asset. An uncorrected deformity may often be the result of parental obstinacy, but not infrequently it is due to a want of knowledge on the part of the practitioner. We have only to visit any out-patient department to be satisfied as to the prevalence of the uncured cripple—often the *untreated* cripple. They are seen in every corner of the earth. If we inquire into the causes of these failures, we find that many of them were not seen in the early stages; many were refused hospital accommodation; others admitted into wards had to be evacuated early because of the pressure on beds; others suffered because there had been lack of continuity of treatment; most of them had not been supervised by surgeons sufficiently interested in that type of work. It is evident, if we are to prevent deformity, we must teach the fundamental principles in such a way that the teaching will bear fruit in remote places. We must reach the *practitioner* because we have to trust to him for an early diagnosis, and he should at least know the possibilities of modern treatment. The most effective way to accomplish this is through the mind of the student.

To illustrate the value of early corrective treatment we will consider for a few moments a simple type from each of the four groups from which deformities are derived. From the congenital group we will select an ordinary case of congenital equino-varus.

Congenital Deformities.

It is quite common in England to see these cases left for many months without any treatment of a systematic kind. Indeed, some surgeons of repute speak of postponing treatment until the child can walk. They do not

realize the irregular growth that takes place in the tarsus blocking and fixing the foot with increasing effect. It is quite true that a club-foot requires the final act of walking to complete its recovery, but the deformity itself can be completely eradicated in days or weeks, and by methods which can be easily taught to the practitioner in charge if the attempt is made *sufficiently early*. Every one should be taught that the earlier treatment is started, the better the functional result. How often we hear of "recurrences"; that they take place is constantly affirmed by writers as if they were enunciating a principle. Here, again, it should be insisted that a cured club-foot (an over-corrected club-foot is not necessarily a cured one) cannot recur—an over-corrected one frequently does. It is futile to correct obstructive and skeletal elements if the other factors are ignored. One of the causes of these so-called "recurrences" is weakened over-stretched dorsiflexors and peronei. Until the child can over-correct its own deformity by a voluntary act, the foot is subject to the same influences that bring about foot-drop in infantile paralysis. If you examine many so-called "cured" club-feet, you will note the weakened condition of these muscles; if simple methods of treatment were applied for rectifying the deformity and restoring the function of the foot, there would be no need for enbrous antiquated instruments reaching to the pelvis to keep a foot from turning in. Such implements suggest a serious misunderstanding of fundamental principles.

Rickety Deformities.

Take another group of deformities—those associated with rickets. The etiology of this condition is sufficiently known to merit some organized method of control. Recent investigations with regard to vitamins have served to confirm us in our view that it is largely a dietetic disease intensified by insanitary conditions. It is the practitioner who, here again, appears first upon the scene. He knows that mother's milk is better than the pernicious substitutes, and he knows the benefit of fresh air and the evils of overcrowding. If he preached this doctrine with enthusiasm, considerable headway would result in the prevention of rickets. When the disease appears he should know of the danger to soft bones of crawling and walking; he should realize the direct harm done to the child by the way the mother carries it; and, later, when deformity has become evident, how dangerous it is to tell the parents that "the child will grow out of it." When the bones are soft, the recumbent position, a frame and a bandage, without any drastic surgical methods, will correct the worst deformities in the young, and the bones will harden in their correct alignment provided feeding is suitable and the child is kept in the open air and not allowed to walk until the bones are firm.

Then we surgeons are often to blame when the rachitic come to us with their deformities. It is the osteotome, the saw, or osteoclast which we rely upon to straighten the limb, but how rarely do we take adequate protection against recurrence! Our out-patient departments abound with cases in which deformity has been corrected, and has recurred worse than ever, because of deficient after-care. This very properly brings our surgical methods into disrepute. For here again we have not merely to correct the deformity, but to cure the disease—not merely to straighten the soft bones, but to harden them. Deformities of the extremities should never be allowed to occur in rickets, and to fail to rectify them if they appear is a reproach either to the parents, to the surgeons, or to both. If the deformity, having been corrected, returns, it is a serious reflection upon someone.

Deformities due to Tuberculosis.

Again let us refer to tuberculosis in children. We should be able, given reasonable State facilities, to eradicate this dreadful evil from our midst. If it does appear we should be able to prevent any deformity due to faulty alignment. Most practical and suggestive work on the etiology of tubercle in children, as you know, emanated from Edinburgh under the direction of Sir Harold Stiles, assisted by Mr. Fraser and Mr. Mitchell, who, with scientific methods and infinite labour, traced the infections from cows to children, and were able to correlate their clinical and pathological findings. No less than 60 per cent. of bone and joint disease were due to bovine infection. They found that 37 per cent. were due to the human bacillus, and in 62 per cent. of the human type a history of pulmonary

trouble existed in a parent whereby direct infection could take place. These experiments should be repeated on a large scale all over the country. Even now, at a minimum computation, one specimen of mixed milk in every ten contains living tubercle bacilli. Stenhouse Williams, an acknowledged authority, states that about 30 per cent. of the cattle in this country are affected with tubercle, and that of the total cattle only 2 per cent. will be in such an advanced stage of disease as to be affected by the Tuberculosis Order. "What," he pertinently asks, "is to become of the remaining 28 per cent.?"

What good can result by promulgating theories as to the immunizing of the race by feeding our children on living tubercle bacilli when we see the havoc and tragedy around us? It discourages any preventive effort which the State may make, and supplies the careless dairyman with an argument of immeasurable evil. Is it too much to insist that our milk should be so purified that no living tubercle bacillus should be allowed to enter the mouth of a child? The practitioner here again has a great gospel to preach. If in spite of all a joint becomes involved it will come under his observation first. Again, I have only to refer to the deformities of tuberculous joints, and to insist that a knowledge of the beginnings, and of the sequence of events, would relieve our hospital beds of much pressure and the child of much suffering.

Deformities after Acute Anterior Poliomyelitis.

We do not know enough of infantile paralysis, in spite of the investigations that have recently been made by Flexner, Clark, Osgood, and Lovett, but we have sufficient knowledge to treat it as a dangerously infective disease which should involve placing the family in quarantine, and guarding the healthy children as strictly as they would be guarded against any other acutely infectious disease. The early treatment of infantile paralysis, again, is in the hands of the family doctor. The surgeon very rarely sees the case in the acute stage, and then only when pain occurs or paralysis is discovered. Treatment should be undertaken at once, and should consist of complete rest of the nerves and muscles. I should make it a rule in every case, whether pain is present or not, to keep head and spine at rest just as if we were treating an inflamed area. During both the acute and early convalescent stage the treatment should be protective, and this term should include the prevention of postural errors such as tend to give an initial bias towards deformity. The rapid recovery of muscular groups in extensive paralysis suggests a pressure upon nerve cells which, under given conditions, is rapidly dispersed. Complete destruction of nerve cells is comparatively rare—hence the very late recoveries which often follow treatment. The family doctor may materially shorten and limit the disease, and prevent infection by early rest and isolation, while the risk of the advent of deformity and functional disability can be materially lessened by recognizing as a principle that the paralysed muscle should not be allowed to stretch.

Orthopaedics in the War.

Nearly all the crippling deformities of children and adults are included in the branch of surgery which, for the want of a better name, we call "orthopaedic," and the upper and lower extremities present its main field of activity. This type of surgery formed a large proportion of the injuries of war, and it will readily be admitted that many early failures would have been avoided if British university and hospital training all over the country had embraced in the curriculum the practical teaching of orthopaedic surgery.

Frequent visits round our Command Dépôts revealed the shortcomings of the routine teaching, for one found segregated every type of deformity; most of it need never have occurred had sufficient time been spent in educating the student in the principles which govern the development of deformity. These revelations implicated not merely auxiliary hospitals, but the best known hospitals in the land. The cases we met with were malunited and ununited fractures, stiff and ankylosed joints, injuries of peripheral nerves, partial destruction of the spinal cord, faulty fixation of joints, deformities due to the contraction of scars, and malposition due to functional causes. We found ankylosed joints being massaged, the limb often fixed in the position of least functional usefulness. We found old arthritic joints being

moved with calamitous results, simple adhesions treated as if inflammatory activity were present, the after-effects of peripheral nerve injuries treated without regard to the stretching of paralysed muscles; frequently cases in which nerve had been sutured arrived at the camp without any protection for the disabled muscle, and many cases had been allowed to contract so as to deprive joints and fingers of all usefulness. These tragedies did not necessarily originate in Command Dépôts, but often arrived there when the mischief had been done. They were not all necessarily due to ignorance or neglect; often they were the result of scarcity of beds, early evacuation, want of continuity of treatment, but the conclusion was also forced upon one that they displayed a lack of orthopaedic training on the part of surgeons and practitioners generally. The Command Dépôts in point of fact presented large groups of cases where Nature unassisted had been allowed to do its curative work without regard to restoration of function. The orthopaedic mind is taught to think in terms of function. It has mainly to deal with a pre-operative and a post-operative stage. The operative stage, although often essential, has only a proportionate value. Orthopaedic operations are usually measures preliminary to the re-education of muscle and restoration of function. They include the maintenance of joints and limbs in proper position in order that injured tissue may recover functional efficiency. The period of disability is materially shortened if the limb is protected against deformity while the wound is being allowed to heal. We may be certain that gross malunion of a fracture is not only deplorable but preventable. Most of the malunited fractures of the war were due to the inefficient fixation of the limb in the presence of sepsis, or to inexperience of the surgeon in regard to completion of consolidation. Later in the war, the soft tissues were allowed to heal with the bone in good alignment, and this position was maintained while body pressure was permitted. Attention to these two points resulted in a marked decrease of deformity, and, in consequence, an improvement of function. Even yet surgeons do not fully realize that a fracture of the femur which has recovered sufficiently to be unyielding to manipulation may yield to the incidence of body-weight. Pain on pressure over the site of fracture suggests an unsound or delayed union. Pain on pressure, and an excessive callus display, requires special protection in order that yielding may be avoided.

The deforming contraction of scars which we found in Command Dépôts could be avoided by recognizing certain principles. The wound should be allowed to heal with the limb placed in a position opposed to the contractile force, and the surgeon should remember that the bigger the mass of granulation, the more massive and contractile the organized fibrous tissue proves. Wounds in the axilla should be allowed to heal with the arm abducted; in the flexure of the elbow, with the forearm extended; of the wrist and palm, with the joint dorsiflexed, and so on with the other joints. Fully matured fibrous tissue has no more tendency to contract than any other tissue; as a scar takes a long time to be composed of fully matured tissue, the precautions taken against contractures must be prolonged.

It was in consequence of this ever-increasing stream of deformity that the Orthopaedic Centres were started, where the principle of segregating special groups of cases came to be recognized as clamant. From all parts of the country cases poured in. We started with 250 beds in Liverpool, and rapidly extended into the principal towns of Great Britain and Ireland until our beds eventually numbered over 20,000. The staffs were made up of general surgeons, orthopaedic surgeons, neurologists, and chiefs of special departments. We were permitted to keep our cases longer than in the general military hospitals, and were given every modern facility in the way of equipment. For psychological and reconstructive purposes we introduced the curative workshops. These Orthopaedic Centres completely transformed the mental attitude of the derelict, and inspired every surgeon who worked there. The spirit of friendly rivalry and enthusiasm which infected all became part of the atmosphere. Consultations among the members of the staff were of daily occurrence. Any advance made by one surgeon was at once the common property of all. There were no watertight compartments anywhere. The successes and the failures were equally advertised without

mental reservation, and the secretive mind had no place amongst them. Needless to say, that spirit of comradeship and interest in each others' achievements and failures could not fail to make for progress. Each surgeon followed his case from the beginning to the end. It did not pass from one department to the other without an agreement as to the continuity of treatment. The surgeon discussed the line of treatment to be adopted with the chiefs of the special departments, and at stated intervals all the cases were collected, so that progress might be recorded and alterations discussed. As time passed, it was found that certain surgeons had special aptitude for dealing with certain types of cases, and they were encouraged to devote themselves to these and refrain from work which others could do better. This principle of employing a special talent and discarding lesser ones will doubtless in time come to obtain in our general hospitals, to the great advantage both of the surgeon and of the patient. The growth of surgery has been so rapid of recent years that only a very few surgeons have been sufficiently gifted to deal efficiently with all types of cases, and it is common to hear from old students that certain chiefs were only interested in the surgery of the nervous system, or of the abdomen, or of the extremities, and yet they had to plough through the uncongential work as best they could. Their brilliance in one department was tarnished by their lower efficiency in another. A spirit of comradeship whereby the staff would interest each other in the work in which they each excelled would result in a sound, practical education, and in impressing upon them their values and their limitations.

The advantage of segregating certain cases under surgeons specially interested in them has been proved by the experiences of war. It was very marked in the case of fractures. In the early days of incomplete organization nearly all the fractures of the femur admitted into special surgical centres exhibited marked malunion and deformity. Some were treated abroad, but most of them were treated in general hospitals in this country. Rapid evacuation at home and abroad due to military exigencies, and, often, defective handling by surgeons with no mechanical training, accounted for an appalling number of deformities, many of which took years to rectify. Later it was recognized abroad that these cases should be segregated, and it was most interesting to note the improvement that occurred. By this time the principle of the Thomas knee, bed, and calliper splints, with modifications introduced to facilitate the treatment of large wounds, was recognized. The cases arriving from the fracture base hospital at Boulogne were invariably so well placed, both as regards fixation and alignment, that they rarely required more than casual attention; when some relapsed into deformity it was due to ill-advised changes adopted by surgeons at home, who frequently removed the splints too soon, and allowed walking before consolidation had occurred. Cases which had given skilled surgeons abroad the greatest anxiety and endless care, on arriving home failed to secure that continuity of good treatment essential to success. I received many a heart-breaking letter from abroad complaining of all this. Several special fracture hospitals were opened in France later, and, as a result, an end came to deformity. After the bombing of Etaples all fractures were sent home, and the expert staffs were housed in our special orthopaedic centres. At one time at Edmonton we had 300 cases of fracture of the femur with an average shortening of less than half an inch. This is an extraordinary achievement when we consider the severity of the injuries. Results equally good were obtained at Alder Hey by the use of the Thomas splint employed in its original simplicity. The lesson we gather from this is that by simple methods taught in a few hours the practitioner in remote places can be safely trusted to start a fractured femur on a safe career.

A general training in the treatment of fractures would have saved thousands of lives during the war. If our universities and teaching hospitals would fix upon the simplest types of appliances, and thoroughly ground the students in the principles which govern the application, humanity may yet be spared numberless deformities. The appliances should be of the simplest kind to be of wide-spread use. In every large hospital there should be a fracture ward, and the chief should be both interested and competent. The treatment of fractures in this country is at present a sadly neglected art, and every effort should

be made to place it on a more scientific plane. A walk round our hospital wards indicates clearly the apathy displayed by many surgeons. Fractures are looked upon as a nuisance and generally relegated to a junior house-surgeon, who, in his turn, exhibits but little interest or ingenuity. The surgeon's attention is devoted to the vagaries of the abdominal contents, and he has no desire to waste his time or beds on mere fractures. His attitude of mind finds its reflex in that of the students. The crippling and deformity is looked upon as a necessary sequence of injury rather than as a reproach.

When our military Orthopaedic Centres were started their extension was hindered because we had at our disposal only a few men who had received special training. At that period every young man was expected at the seat of war, and only a very few could be spared for home work. The American Government, realizing our plight, very generously sent us twenty-five well trained young orthopaedic surgeons, who were to help us, free from expense, for the duration of the war. Without that help we should have been very seriously handicapped. In return for this we undertook to train large numbers of their young surgeons at our centres to enable them to be of greater service abroad. This training specially fitted them to deal with injuries of the extremities, and they received an intensive education in the use of a few well considered splints which were standardized by the American Government. These splints were plentifully supplied to the whole of the medical service, together with the code of instructions. By this means in a very short time they were enabled to acquire knowledge which we had learnt only from litter experience. They distributed splints at once to the regimental aid posts; each knew the working of the splint, from front to base, and so continuity of treatment was secured along the line. What a saving of life this represented! Sir Henry Gray, in 1916, collected statistics over one of the army areas, and found that 80 per cent. of compound fracture cases died, mostly before arriving at or after they arrived at the casualty clearing stations; and when, in 1918, immediate fixation in the Thomas splint was secured at the first possible moment, Sir Anthony Bowly tells us that the mortality was reduced to 30 per cent. This is an interesting reflection in regard to team work, the treatment of shock, and the standardization of simple methods. It would be a calamity if the knowledge forced upon us in such strenuous times and through so much sacrifice were lost in time of peace.

Need for Orthopaedic Training.

We hear frequent criticism from both continents of the lack of orthopaedic training in this country. While lectureships and clinics abound abroad, it is only quite lately—and this largely owing to the war—that there has been a very strong feeling expressed in this country as to our need of orthopaedic instruction. I think this is due to the limited definition which has so long been associated with the term "orthopaedics." So long as the specialty was confined to flat feet, knock-knees, club-feet, and certain other deformities, it seemed useless to trouble about it. So long as expensive, cumbersome, and consequently useless appliances were in evidence, one is not astonished that the surgeon not only neglected Orthopaedic Surgery but looked upon it with contempt! Fortunately, however, that day is past. It is now recognized that an essential preliminary to orthopaedic efficiency involves a thorough practical training in general surgery. With a gradual expansion of its definition a higher degree of skill is demanded by its votaries, and no one will now venture to practise it with any false notion that the road is an easy one. In addition to operative skill, it demands special qualities of mind; mechanical aptitude and untiring perseverance and patience are not the least important of these.

Since the war several hospitals have decided to embrace in their curriculum the teaching of Orthopaedics, and I have often been asked to help in regard to organization and requirements. An Orthopaedic Department is too often a mere outpatient clinic, sometimes under the control of a physio-therapist with no supervision by a specially trained surgeon. At times a junior man is in control, with no interest but to make it a stepping-stone to another post, which he accepts with alacrity at the earliest opportunity. This is, of course, futile, and can bring nothing but discredit upon all concerned. It is

better to have no orthopaedic department at all than to make it a pretence. The essential and fundamental corner-stone of an Orthopaedic Department is a surgeon who knows his work and intends to devote his life to it. Less than this dooms any scheme to failure.

Organization of an Orthopaedic Department.

At the risk of repeating what I have said in other places I venture to put before you my ideas as to what an Orthopaedic Department attached to a university or teaching hospital should be. Whatever definition of Orthopaedic Surgery is adopted, the general surgeon should have a perfect right to admit into his wards, for teaching or other purposes, any case or as many as he likes included in that definition. The Orthopaedic Surgeon should alone be limited, and should be precluded from treating any other cases except those covered by the definition.

No Orthopaedic Department should be confined to the treatment of out-patients. It should be a complete unit, with beds commensurate with out-patient demands.

The staff should consist of an Orthopaedic Surgeon, who should be in charge of the department and be responsible for its efficient conduct. His practice out of hospital should be confined to Orthopaedic Surgery. He should have a seat on the medical board and hold rank equal to that of the general surgeon. An Orthopaedic Registrar or assistant surgeon, who should be selected as a man desirous of practising Orthopaedic Surgery. A house-surgeon, who should be appointed for at least six months, and clinical assistants and dressers.

The staff should run as a team, in which the nurses play an important part. It is important, therefore, that the matron should give security of tenure to the sisters in charge of the ward and out-patient department. It takes much time and perseverance to train nurses in this particular work, involving, as it must, the application of splints and the renewal of plasters; a considerable responsibility attaches to them. For these reasons they should remain part of the permanent staff.

In a hospital of 500 surgical beds I have estimated that forty should be retained for the orthopaedic service. They should be segregated. The department should have well-equipped physio-therapy rooms under the superintendence of a chief, who should, of course, be a member of our profession.

The orthopaedic registrar (or senior house-surgeon) should hold his appointment for at least two years. If his work proved sufficiently promising, opportunity should be given to him during his tenure of office to visit clinics at home and abroad in order that the hospital work and university teaching should be kept well in advance; this educational course should be financed from hospital funds, and the clinics to be visited could be arranged by the orthopaedic surgeon. The registrarship should be a whole-time appointment, and the assistant surgeon should be understudy to his chief.

The plan of one officer being appointed head of all sections of physio-therapy has much to recommend it. The post is a very responsible one, and presupposes a knowledge of massage, physical exercises, and electro-therapeutics, and possibly hydro-therapy. Although the physio-therapy department should be closely allied to the orthopaedic, it should still be independent of it, because it is a department used by all the physicians and surgeons.

Difficulties sometimes arise between the chief of the physio-therapy department and the rest of the staff on the question of responsibility. It is well, therefore, to define their relationship clearly in order to harmonize work. The rules which are in force at the Liverpool Royal Infirmary and St. Thomas's Hospital, London, with both of which hospitals I am associated, are satisfactory, and are as follows:

Rules for a Physio-therapy Department.

(a) In-patients can be sent to the department with general instructions that they require treatment. In such cases the nature of the treatment will be decided by the medical officer of the department, who will be entirely responsible for the case, and who will only refer such cases back at his own discretion or on a definite request from the physician or surgeon who originally had charge of the patient.

(b) Cases may be sent to the department by the physicians or surgeons with a definite request for certain detailed treatment.

Such cases will be sent back to them at stated intervals. Should any sharp difference arise between the medical officers of the department and the honorary surgeon, the honoraries will take full responsibility.

(c) Cases sent by casualty surgeons should be under the control of the chief of department.

These, or similar rules, will settle the tendency to friction which might possibly occur, but obviously friendly consultation and understanding is the only real basis of good comradeship.

In a teaching hospital with a large out-patient clinic there is a great advantage in starting a workshop for the manufacture of splints. It is not only an economy, but it adds immensely to efficiency, and affords the surgeon an opportunity to develop his mechanical ideas.

The Scope of Orthopaedic Surgery.

When we begin to discuss the scope of orthopaedic surgery, the atmosphere is perhaps not quite so clear. On the one hand, it is desirable not to limit the activities of the general surgeon; on the other hand, it would be unfortunate to deprive the orthopaedic surgeon of work he has been trained to do. The general surgeon is protected by the right he undoubtedly has to treat any case he desires, and justice will be done to the orthopaedic surgeon if he is allowed to admit to his wards those cases which, in ordinary circumstances, he would undertake in private. I think these cases should consist of:

- (a) Congenital and acquired deformities of the spine and extremities.
- (b) Infantile paralysis after the acute stage.
- (c) The deformities of adult paralysis.
- (d) Stiff and ankylosed joints.
- (e) Torticollis.
- (f) Disabilities of joints, such as rupture of crucial ligaments, injuries to semilunar cartilage, snapping hip, slipping patellae, and those conditions which are included under the aggressive title of "bonesetting."

I think also that the orthopaedic surgeon should have the right, in common with the general surgeon, to treat recent fractures. If he is competent to deal with mal-united fractures, he should find it easier to prevent deformity than to reconstruct the limb. I have already dealt with the necessity of segregating fractures, and a very healthy rivalry would be maintained between all the surgeons interested in the branch of work if the cases were under close observation in one ward, presided over by nurses specially qualified to nurse them.

This definition admittedly covers a large area of surgery, and for this reason will attract the very best of our young surgeons. These are the men whom we specially desire to attract in order that they may devote themselves to a very intricate branch of work, bristling with problems which require solution, and demanding the highest operative skill.

The Teaching of Orthopaedic Surgery in a Medical School.

Well, given our Orthopaedic Department with its complete equipment and well organized staff, what part is it to take in the training of students? It should take a place, I maintain, proportionate to the area of work it covers.

It is useless to suggest that the student's time is already fully occupied. The endeavour is that it should be better occupied. All the subjects embraced in the definition have to be taught, and the proposal is that some of the teaching should be delegated to a department efficiently staffed for the work. The student is not asked to give more time, but is offered greater facilities for acquiring knowledge. I do not think that a university or teaching hospital can at first face the problem of training both graduate and undergraduate. The courses should be separate and, in the case of the graduate, he should have facilities for doing a considerable amount of clinical work. The undergraduate training is a more pressing and important problem. My suggestion is that a student is more fitted for orthopaedic training towards the end of his curriculum than at an early stage. It is, of course, essential that his attendance be made compulsory for a specified number of attendances.

The orthopaedic chief should carefully prepare a

systematic course of clinical instruction to be given once a week at an hour which fits into the curriculum, and the student should be required to show at least twenty attendances. The demonstration should last for about two hours. For instance, one afternoon might be devoted to the discussion of club-foot, illustrated by living specimens of every type; the deformity of the newly-born contrasted with that of later life; the nature of the deformities and the effects of weight-bearing; the fundamental principles of treatment governing success or failure; the various gaits and the tests of recovery. All this could be taught with a wealth of illustration, together with a detailed demonstration of the various methods of manipulation and fixation, and of muscle re-education. The student could here have instilled into him the tragedy of removing bone before a preliminary reduction of deformity by forcible means had been effected. The demonstrations should be simple in character, very practical and quite free from controversial matter. Most of his instruction could be given in the out-patient department, which is a more wholesome place for elementary study than the more attractive operation theatre. He should be thoroughly taught, and that by actual practice, the principles underlying the application of plaster and the objects to be obtained by appliances. All this can be done to great advantage if the cases are grouped in such numbers and order as to impress upon the student's mind the difference in degree and type. One afternoon could be devoted to stiff joints, starting with the various types of ankylosis; impressing the importance of position in regard to function; illustrating the various types of arthritis and the differential diagnosis between these conditions and joints bound down by adhesions; the mobilization of joints by safe methods contrasted with those of danger, ending by a practical exhibition of procedure. The student should not be allowed to leave the clinic until he has a knowledge of the practice of physiotherapy. There is no better place than the out-patient department for the teaching of the treatment of fractures of the upper extremities by splints with mobilization. The Orthopaedic Surgeon, in combination with any members of the staff who are interested, should form a committee in order to fix upon the appliances which, by reason of their simplicity and efficiency, may be safely standardized, and the student should be obliged to become thoroughly conversant with their use by frequent exercise in their application, both in the out-patient department and in the wards.

Country Hospitals for Crippled Children.

Country hospitals for children, staffed by well trained surgeons, are essential to any scheme dealing with cripples. Having been associated with such hospitals for over twenty years, I can speak with some authority. I have worked at hospitals where children are indoors day and night, in others where they are out during the day and in at night, and in others where the children are out day and night, and there is no comparison as to their relative values. Children out in the open air day and night are at a great advantage. I think one can prophesy that the time will soon come when the town hospital for children will practically cease to exist. The energy, vitality, and nutrition of the children brought up in open-air wards are a revelation to all who visit them. Infectious disease, the bane of closed wards, never spreads when the wards are fully exposed to fresh air; no matter how low the temperature, the children never take cold. Such a hospital should be attached to every teaching centre, and in every orthopaedic scheme it should hold an important place. This hospital should not be a convalescent home if by the term is meant that no active surgical work is done there. It should be equipped with an operating theatre, plaster rooms, and a physiotherapy installation. In this way nurses can be trained to do special work and obtain their massage certificates—which involve a working knowledge of electro-therapy—and young surgeons gain much-needed experience in the way of practical work.

Some of you may have seen such institutions. We have at Heswall, near Liverpool, due mainly to the vision and generosity of Mr. Andrew Gibson, one of the most beautifully situated hospitals in the world. It lies above the banks of the Dee, surrounded by heather, facing the Welsh hills. One side of each long ward is completely absent; and it is an inspiration to see how everybody—nurses, children, and staff—reflect the joy of living. Treatment

is intensive, for every factor is present which ministers to recovery. The orthopaedic department should have a considerable number of beds in such an institution as this, retaining only a comparatively small number in the town for the more acute conditions and for the purpose of teaching. The surgeons from the city should have their regular visiting and operating days, and some of the clinics should be conducted there.

There is another type of hospital at Baschurch, in Shropshire, which was the first open-air hospital ever built. The wards consist of wooden sheds built upon an open field. The operating theatre and the post-operative wards were largely built by cripples. There are four well known orthopaedic surgeons attached to it—one lives in London, another in Birmingham, another in Oxford, and one in Liverpool. The operative work is all done on Sundays, and each surgeon pays a visit once a month. They are all busy men, and yet, so fascinating is the work and its environment, that they look forward to the visit with eager enthusiasm. This is a sufficient answer to any argument that may be employed in reference to distance. A country hospital in association with a teaching centre need, however, only be a few miles from the city.

This hospital at Baschurch has spread its net over a large area in Shropshire. The difficulty of reaching cases in an early stage and in securing adequate after-care, led to the formation of clinics or subcentres, in small townships. There are at present about seventeen of these. Every week or fortnight one of the house-surgeons, accompanied by an orthopaedic nurse, visits each centre. New cases are examined, treated, or referred to the main hospital. Old cases arrive for reapplication of plaster, splints, or appliances. In attendance at these clinics are usually found a representative from the medical officer of health, the school doctor, the local doctor, and representatives of the invalid cripple aid and child welfare societies. You can imagine how inspiring it is! This association and discussion in remote townships disseminates a spirit of helpfulness and enthusiasm which will largely help to solve the cripple problem. The National Scheme, drawn up by Mr. Girdlestene, and published by us,¹ now in the hands of the Central Committee for the Care of Cripples, was inspired by the work so excellently begun and carried on at these two open air hospitals.

Diplomas and Degrees in Orthopaedic Surgery.

Post-graduate teaching must be prepared for two types of students—a short course for a graduate who can only spare a few weeks, and another of a more intimate kind for those who desire to qualify as expert orthopaedic surgeons. The former will be composed of men who feel the responsibility of not knowing, and should be welcomed and helped, and the tuition should be carefully planned so that the education may be intensive. The university should, however, be prepared with a higher course of training lasting from one to two years, in order to qualify the surgeon to be admitted for a diploma or a degree. During this course the student should be given every opportunity of approaching the subject in its scientific and practical bearing. His curriculum should not allow him an idle moment, and the anatomical, physiological and pathological departments should occupy a considerable portion of his time. If his work has been satisfactory he may obtain a diploma from the university at the end of the first year; and if he studies for the second year he will require to take an assistant's position at one of the hospitals, perform most of the operations that may be required of him in practice, and write a thesis based upon original research. This may secure for him a university degree in orthopaedic surgery. I am pleased to say that, on the initiative of Professor Adams, our Vice-Chancellor at the University of Liverpool, we are engaged in working out the details of such a scheme for the advanced group.

Proposed Orthopaedic Department for the University of Edinburgh.

Now may I be allowed to refer to the University of Edinburgh, which, I am rejoiced to learn, is about to found an Orthopaedic Lectureship? I do this with less hesitation as I am sure that such old friends as Professor Alexis Thomson and Sir Harold Stiles will pardon an enthusiast who loves his art perhaps to the verge of indiscretion. Edinburgh is the largest medical school in

the British Empire, and has traditions envied by all. For generations it was the last word in education. Its graduates are found in every part of the globe, and they display an affection for their Alma Mater and an admiration for their teachers which in my experience is unique. For years I appointed as my house-surgeons Edinburgh graduates, not because of their practical knowledge, which was often deficient, but because they had been carefully taught how to observe. There were many men who had come into closer contact with their patients, who had been given more responsibility, but for receptivity of mind and the ingestion of new ideas the Edinburgh student always excelled. In early days, when views I held were less popular, I knew so well their incredulous look, and how closely one had to reason in order to convince. I recall the case of one man, now a distinguished orthopaedic surgeon and a close friend, who, after following my rapid flight around a ward, pushed into the board-room when I was putting on my coat, leaned against the table, and almost angrily pelted questions at me; and when in a timid way I tried to answer him, he clinched all argument by an unanswerable sentence: "This is not Edinburgh teaching." Edinburgh graduates, over and over again, have complained to me of their lack in orthopaedic training even up to recent years.

This is not worthy of a university of so singular a reputation, and which has always displayed an almost fatherly solicitude for the efficiency of its graduates. Now that it is about to make up for its deficiency, I commend for its consideration a scheme such as that which I have advanced. When the work starts let it begin on good lines for defects soon become stereotyped, and are always difficult to amend. At St. Thomas's Hospital in London they have started their department on progressive lines. At King's College in London, also, a distinguished orthopaedic surgeon runs his unit, and has been granted forty beds together with the treatment of fractures. I would like to see the new Orthopaedic Department at Edinburgh add lustre to the glorious traditions of the University.

With the generous gift, which is soon to be expended on a new country hospital, what a magnificent prospect is opened up! It can be started on the most modern lines, with an unequalled equipment. I trust the children will be allowed to live in the open air. Surgeons might renew their youth by working in such ideal surroundings, and the child have the benefit of skilled supervision from first to last. The chronic case could be educated, trades taught him, and a spirit of joy and hope would reign. Those who minister to it in any capacity will realize that they are not only doing a personal and kindly service, but one of invaluable importance to the State. I should rejoice to see such an institution become a national centre for the prevention and cure of cripples in Scotland, spreading its influence over the whole of the land, and conducting an educational and reconstructive campaign of inestimable service to mankind.

REFERENCE.

¹ BRITISH MEDICAL JOURNAL, October 11th, 1919, p. 457.

A PRELIMINARY NOTE ON THE USE OF VITEX PEDUNCULARIS IN MALARIAL FEVER AND IN BLACKWATER FEVER.

BY

LIEUT.-COLONEL J. C. S. VAUGHAN, I.M.S.,
LATE CIVIL SURGEON OF RANCHI.

HAVING noted the occurrence of a large number of cases of blackwater fever, and also of a very severe malignant malaria in the Ranchi district, I made inquiries as to whether there were in this locality any plant with virtues similar to those of *Aphloecia theaeformis* (which is used in these conditions in Madagascar), and was informed that there is such a plant actually used by the aboriginal tribes, and that blackwater fever does actually occur among them was evident enough from the clear description of its leading symptoms given me by one of themselves, who sent me samples of the leaf of the plant used.

This plant is locally known by various names:

1. Hindi Minjurgorwa, Chhagriamba, Charaigorwa, Nagpheni, Nagbail,
2. Uraon Erataikha.
3. Kol Simjanga.
4. Bengali Baruna, Goḍa.
5. Assamese ... Osai.
6. Santali Padumarak, Bhadumarak.
7. Cachari Hila Anwal, Krawra (Pra. 2).
8. Garo Shclangri.
9. " Navaladi.
10. Burmese ... Kyetyo.

Of these vernacular names, numbers 4 to 10 have been taken from J. S. Gamble's *Manual of Indian Timbers*, 1902 edition, p. 541. The superintendent of the Royal Botanic Garden at Sibpur has identified the plant botanically as the *Vitex peduncularis* Wall (variety *rorburghiana*). I find it mentioned also in Kirtikar's and Basu's *Indian Medicinal Plants*, Part II, page 1001, and figured, but not very accurately, in their plate No. 741. They give its habitat as "Bihar at Parasnath, Eastern Bengal, and Khasia Terai," and state that "in Chittia Nagpur the bark is used for making an external application for pains in the chest (Rev. A. Campbell)."

The plant is fully described in the two works mentioned above, and in Haines's *Forest Flora of Chota Nagpur*. It is only necessary to add that the leaf characters vary somewhat with the age of the plant, the petiolar expansion on the leaf stem being very inconstant in the older specimens. The aborigines state that there is a variety of vitex with a dark-coloured root—they call it a "red root"—and that this is better to use than the usual pale-rooted plant, which, however, is the only kind I have been so far able to obtain and to use.

My information is that it is used in various ways, chiefly as an infusion of the leaves or of the root bark or young stem bark, in fever of malarial type, and especially in blackwater fever. As to the dosage, I followed in the first instance, since October, 1919, and in the main still follow, what amounts practically to the original directions given me by my Uraon informant as regards the method of use. These are as follows:

Two ounces of the leaf used fresh, or dried in the shade, is dropped into 40 oz. of boiling water, and is boiled in it for five to ten minutes, and then allowed to soak in the water in which it has been boiled, for an hour at least. The resulting infusion, amounting to about 40 oz., is poured off the soaking leaf and given as required in doses of about 8 to 10 oz., distributed over twenty-four hours, or given over the day only, the patient resting all night undisturbed. The infusion is of about the colour of strong cold tea and not unlike it in taste, and is given sweetened with a little sugar to taste.

As soon as we decided by the results that the infusion was quite a useful preparation, we attempted to prepare a concentrated infusion on the lines of the infusion gentiana-compositum (conc.) of the *British Pharmacopoeia*. This has also proved useful, but we found it less reliable than the simple infusion of 1 oz. to 2 oz. of leaf yielding 40 oz. of infusion with plain water. With further experience we found it in certain cases necessary to give larger doses, and to avoid too great a volume in each dose we prepared a 40 oz. infusion from 1, 2, and 4 oz. of leaf, and we called these, for easy reference, infusions of 1 in 40, 2 in 40, and 4 in 40 strengths, and used these as required.

As to results, generally speaking, in malarial fever, we have in almost all instances identified the parasite of malaria before commencing the treatment. This preliminary has only been omitted in a very few of the cases on which this paper is based, and these latter have been, I think, quite undoubted cases of malaria also. The results, as a whole, show that, whereas there are cases that will quite readily yield to a 1 in 40 infusion, there are others that require a very much larger dosage. This may be due to, perhaps, the fact that we have not so far been able to standardize dosage, as the active principle has of course not yet been identified. The actual experience with the use of both the infusion and the concentrated infusion has been that, whereas a proportion of cases have quite readily yielded to a dosage based on the infusion of 40 oz. of infusion from 1 oz. of leaf given over twenty-four hours of administration, and have yielded in some cases in twenty-four hours and in others in the course of seventy-two hours, there have been other cases which have not yielded even in seventy-two hours, but which have yielded at once when the dose was doubled or considerably increased by either giving a larger actual dose of the 1 oz. to 40 oz. infusion, or by using a very much stronger infusion, even up to one of 4 oz. of leaf to the 40 oz. infusion, and there are others which have been even more obstinate. The results, however, have been uniformly encouraging.

The drug seems to have no toxicity at all in the dosages

so far employed, and children have actually been given relatively very much larger doses; indeed, practically the same actual dose as adults, and there are no disagreeable after effects. I append below short notes of some of the cases treated.

As regards the use of vitex infusion in blackwater fever I have so far, naturally, not had much opportunity. I sent out some of this leaf before we had had it identified to certain officers of the Forest Department in response to a request from one of them, and it was used in simple infusion in a case of blackwater fever occurring in a forest ranger, and the report is given below charted out. His urine cleared to a natural colour after nine doses of infusion of 1 oz. of leaf to 40 oz. of water given over forty-eight hours, and he made a complete recovery. I also sent some of the leaf to Dr. A. T. Williams, of Kettelah in Assam, recommending him to try it in blackwater fever, and he had the good fortune to get a very severe case which is referred to below. His telegram to me regarding this case sums it up in the words, "Bad case, ten pints infusion completely cleared specimen, recovery." This infusion was also of 1 oz. of leaf to 40 oz. of water.

I would next briefly review some of the cases treated with the preparations so far used made from the leaf.

(A) MALARIAL FEVER.

Case 1.—Sister Sr., an Indian nun, contracted malarial fever, a very malarial locality, in July, 1919. Had been given quinine freely, which checked the fever, but it always came on again at a few days' interval. Admitted in the latter part of October and treated with gr. 5 quinine sulphate tablets for some days with practically no effect, and with quinism following. The temperature on October 26th, 1919, was 102.2°, on October 28th, 100°, when malignant tertian parasites were found. Infusion vitex 1 oz. to 40 oz. infusion, given in the afternoon and repeated four-hourly, and continued until November 3rd. No fever from the morning of October 28th; observation continued until November 7th. No fever all this time and parasites absent from November 4th.

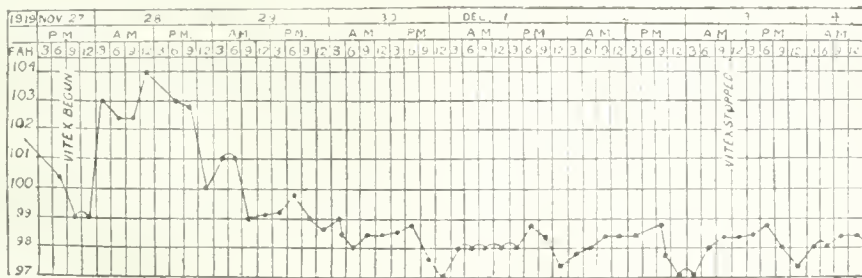

Infusion of vitex 1 in 40 was given from 8.15 p.m. on November 27th, and continued regularly every four hours till noon on December 3rd, when it was stopped; no other drug was employed. The urine, which was blackish-red on November 27th, began to clear on November 28th, became natural in colour about 6 p.m. on November 29th, and continued so.

Case 2.—Timothy, native Christian. Had suffered for several days from fever and had kept at work; treated with 8 gr. quinine tablets t.d.s. for three days. No effect. Blood examined, malignant rings found; put on infusion vitex 1 in 40, and fever absolutely ceased. Kept in hospital for nine days and on treatment, during which time had no fever; discharged. Under observation for fourteen days. No fever.

Case 3.—P. B. B., Bengali male. Admitted on October 30th, 1919. Temperature 104°. Benign tertian. No fever on October 31st or on November 1st. Fever recurred November 2nd, parasite found on the 3rd, and patient put on infusion vitex 1 in 40. No more fever. Under observation for over ten days.

Case 4.—Sister St., Indian nun from Rengari. Fever since July. Repeatedly treated with quinine. The temperature on November 5th, 1919, was 104°, on the 6th 102°, and on the 7th 99°. Malignant tertian parasite found. She was not admitted to hospital, and took at the convent vitex infusion 1 in 40 in half quantities only, with practically no effect until November 15th, when she was admitted to hospital and put on full dosage. The temperature after this gradually and steadily came down, and, with the exception of one rise on November 20th, to 103°, which fell next day to normal, she had no more fever, and has since made a good recovery. In this case it was clear that the half quantity of infusion was too small a dose.

Case 5.—European male adult. Had frequently had severe malaria. Present attack began on October 28th, 1919, with temperature 104°, when he treated himself with aspirin and quinine—the latter in doses of 24 grains daily—until November 5th, on which day blood showed malignant tertian parasites, and temperature went to 105°, and quinine was discontinued. On the 6th put on infusion vitex conc. ½ oz. four-hourly. Temperature rose again to 105°, and on 7th to 105.4°. On the 8th he was put on 1 oz. of the infusion vitex conc. four-hourly, and temperature fell to 103.6°. On the next day he was put on the simple infusion 1 in 40, and the temperature dropped to normal, and has not risen since.

Case 6.—Mohammedan male, aged about 36. Fever began about December 4th, 1919, and rose on 6th to 103.6° when he came under treatment of an Indian colleague and was put on a fever mixture without quinine. On the 7th the fever fell to

normal, after which he was given quinine sulph. gr. 20. The same evening it rose to 103° and continued at this level till the evening of the 8th, no further quinine being given. On the evening of the 9th it rose again, and on the forenoon of the 10th he was in delirium. I examined the blood on the afternoon of the 11th and from 6 p.m. of that day, malignant tertian parasites having been found, he was put on the 1 in 40 infusion of vitex leaf. By this time he had been continuously in mild delirium for some twenty-seven hours and his temperature was 103.6°. By the morning of the 12th he was free of delirium and of fever and has had no return of high temperature. Vitex was stopped on the 14th. I saw this man again some four months later. He had had no return of malaria during this period.

Case 7.—Hilda Christian aboriginal, aged 15. Had fever at home on December 15th and 14th, 1919. Admitted with temperature 104° on the 15th. No quinine history. On the 16th temperature 104°. Malignant parasites found next day, and patient put on vitex infusion 1 in 40. That evening temperature 102°; on the 18th, 100.4°, on the 19th, 98°, and normal since.

Case 8.—Anandini, Christian aboriginal girl, aged 9. Had had fever for a long time off and on. Admitted to hospital with no quinine history and with a temperature well over 106°. Malignant parasites found on December 16th, 1919, and patient put on infusion vitex conc. 2 drachm every four hours. Temperature on 16th 102.4°, on 18th 98.4°, on 19th 100°, and normal since. Vitex continued until December 22nd; no fever since.

(B) BLACKWATER FEVER.

Case 1.—Dr. A. T. Williams's first case was that of a European tea-planter, a young man of very good physique. Had a previous attack of blackwater fever in 1918; no details available. Then had six months' leave to Australia; back in India in February, 1919. Always neglected quinine prophylaxis and had repeated attacks of fever, generally feeling below par. Had lately been taking a tonic, and felt fitter. On November 16th, 1919, woke up feeling exceptionally fit after a week of intermittent fever malarial during which he had had a maximum temperature of 104° with depression. At 1.10 p.m. passed about 5 oz. of port wine coloured urine. At 2.45 p.m. passed another 6 oz. of the same, and had a rigor and went to bed. Administration of the infusion of vitex leaves 1 in 40 was immediately started. He took it readily and quite liked it. In the evening urine was almost black. At 11.15 p.m. retching and vomiting. At 11.30 p.m. rigor, and temperature 102°. Cramps in fingers and legs. No

sleep. Colour bad; circumoral pallor. November 17th: Deep icterus—one large natural stool, pasty; persistent retching and vomiting all day, neither the infusion nor anything else being retained in the afternoon. Iodine acid, hydrocyanic dil., mustard plasters to epigastrium, and a blister over course of vagus in neck were all tried without success; thirst excessive, mouth very dry. Cramps; vomited matter scanty and "coffee grounds." Rectal salines given copiously. Pulse kept astonishingly good. Total urine of twenty-four hours was 57 oz. of deep claret, almost black, colour. Rectal feeds from the evening. November 18th: Prostration excessive. Champagne, salines and food by rectum. Three six-ounce feeds retained in twelve hours. Vomiting seemed checked by further a.c.d. hydrocyanic dil. Urine began to clear noticeably about noon and continued to clear through the day. Very restless at night. Morphine gr. ½, thirst severe, sleep very broken till 3 a.m. of 18th-19th, and then good till 6.30 a.m. of 19th. November 19th: Marked improvement, no vomiting, resting quietly, thirst less, urine steadily clearing and almost clear by night. Secretion of urine less. November 20th: Urine quite clear. Went right ahead from this onwards, and never looked back.

The urine began to clear forty-eight hours after the infusion was started and continued to clear in spite of a rise of temperature on November 18th. Nothing was given except the infusion. The total amount drunk was approximately 10 pints, but the first five pints were only half strength.

Case 2.—Dr. Williams's second case was that of a Bengali clerk who's alleged to have had two previous attacks. When first seen he had almost complete suppression of urine and severe vomiting. He took about 2 pints of the infusion and refused to touch any more. Everything was tried to get his kidneys going, but without effect. A catheter specimen, obtained about six hours before death, was much clearer than the first lot seen. (These cases of Dr. Williams's are given practically in his own words.)

Case 3.—On November 22nd I received a telegram from the Forest Officer at Manharpur, stating that a forest ranger was down with blackwater fever and asking for vitex leaf (which had not then been really identified botanically). I sent some at once, but it was not until the evening of the 27th that the patient received them. Administration of vitex infusion was

began at once and continued four-hourly. The urine cleared in thirty-six hours and the temperature dropped.

Besides the cases noted in this paper we have treated with vitex in Ranchi some 60 cases of malarial fever, and we have under treatment a case of blackwater fever which occurred at Rengari in a European nun.

This patient had recovered from the original attack of blackwater fever under treatment with *Aphloea theaeformis*, and was brought into Ranchi with her urine still very dark and with abundance of bile in it, and obviously on the edge of a relapse. She was a very severe case to start with, and was in a very critical condition on arrival here. Under infusion of vitex (2 in 40) her urine absolutely cleared in thirty-six hours, her fever came down, and she has made a very good recovery so far.

Now to sum up the results generally. It must, in the first place, be strictly borne in mind that we are but at the very beginning of a very important investigation. It must not be forgotten that in the treatment of malarial fever with quinine—taking the average results of all practice—we get very varying results. There are cases treated with quinine which yield at once in the most gratifying fashion very shortly, if not immediately, after the commencement of treatment. There are others which yield after a week or so, others which persist longer, and others, again, of obstinate types which yield only after the most drastic treatment, or after prolonged treatment, and we are tempted in some few of these latter to ask what the real effect of quinine has been, and whether it has really had any effect. We are accustomed to regard quinine as the specific for malaria, and in prolonged cases yielding only after an obstinate fight we say in practice that quinine has succeeded only after a determined exhibition of it. I am referring now to cases of undoubted malaria. Now, with vitex my experience has been that we have had the same series of varying results—namely, cases that yield at once, others which yield after a short period, others which persist, and others which yield only after a prolonged struggle; and we have had with vitex no experience at all comparable to that of the giving of alkaloids of quinine hypodermically or by intravenous injection. All this, as regards quinine cases, is familiar to most men practising in malarial countries.

There is, however, one very important point of difference at this stage of our investigation, for with quinine we have the finished article worked out to a nicety. The original article was a wild South American forest plant, and now we have all its alkaloidal products differentiated, and the alkaloids have doses that are standards unto themselves and recognized as such. We know the clinical standard value of each of them, and when we come to use them we more or less know what we are dealing with—more with reference to the chemical constitution of the drug we are using, less with reference to what I may perhaps allude to as the coefficient of virulence and resistance to drugs of the particular malaria under treatment. With these two opposing factors we get our varying clinical results with quinine and its allied alkaloids—that is to say, with a series of drugs which have something of a recognized clinical standard value of efficiency. On the other hand, vitex is at present in the stage approximately in which cinchona was when first discovered in the Peruvian forests. The cases I record are the very first fruits, and the singular value of these first observations lies in (1) the extraordinary parallel in the types of the results of treatment with quinine on the one hand and vitex on the other; (2) the extremely encouraging general result of cure which, so far, has practically been as uniform as with quinine. It must be borne in mind that vitex is now in the position in which cinchona was when first discovered—a drug used only in the crudest way by aborigines. The way in which I have so far used it is the aboriginal method. Its results have been good.

I would next point out certain further details and differences.

1. Quinine is extremely bitter; vitex is not so.
2. Quinine produces many troublesome effects and after-effects which I need not dilate on, and is toxic. Vitex produces nothing approaching quinism, and seems to be absolutely non-toxic, and, so far, has given no unpleasant after-effects.
3. Quinine is known to have definite depressing effects on the heart and circulation; vitex, after its use, produces a feeling of well-being, is mildly stimulant, appears to have no depressing effect on the heart, and has a clear diuretic effect.
4. Quinine is oxytocic, and there are dangers in giving it in pregnancy. Vitex, as far as our experience of it goes, has apparently no such dangers attending its administration.

It would appear, therefore, that in *Vitex peduncularis* it may yet be found that we have a most valuable remedy for malaria, and that all that is needed is to work out its properties in detail.

I would add one interesting point which, however, needs investigation. Mr. McLeod Smith, the subdivisional officer of Simdega, tells me that during the last outbreak of influenza in 1918-19 those villages that were accustomed to use this plant for malaria used it in the influenza outbreak and had a mortality definitely lower than those other villages which did not use it. This is but a loose observation from a layman, but acting on it I have so far used it in a few cases of obvious influenza which have recently occurred, with a complete relief resulting after three doses in twenty-four hours of the 2 in 40 infusion of leaf. I give this for what it may be worth as an isolated observation, but I shall push it if opportunity offers.

The root bark and stem bark are also about as useful as the leaves for all purposes for which the latter may be used. This is to a large extent confirmed in my experience.

The infusion of leaves and bark is said to be useful in cystitis. I have found it so in one case. I certainly find it an excellent diuretic.

In vitex it may be that we shall find active principles which will give us all the power of quinine in malaria without many of the dangers and drawbacks of quinine and its allied alkaloids, and we have the most important additional clinical value of this plant in blackwater fever, the scourge of our forest areas and of the submontane tea districts. If future investigation confirms the value of this plant in malaria, it must be strictly preserved in the forest areas of the country. It is widely distributed, perhaps, but none too abundant where it occurs. One may find a hundred plants on a single acre, and travel over miles of forest before he comes across another plant.

Finally, I must express my obligations to all who have helped me in this investigation so far; to Kuril Kerketta of Kuruskela in Ranchi District, my aboriginal informant, who put me on to the leaf and plant; to Mr. David McLeod Smith, subdivisional officer of Simdega in this district, for his keen all-round help, and for much information as to the aboriginal and local names of the plant and its local uses, and for collecting the leaves and bark; also to Mr. E. Durham-Waite for the first clear botanical specimens put up; and to Miss McDonald and Dr. Arit of the Society for the Propagation of the Gospel Mission Hospital, and to Mother Henriette of the Ursuline Convent at Ranchi, and Assistant Surgeon Garib Das Gupta at Ranchi, and Subassistant Surgeon Khudiram Mukerjee of Simdega, for all the help they have given me in various ways in clinical work, and in collecting leaf and bark.

DETAIL OF PREPARATION SO FAR USED.

1. *Infusion of leaf*—in three strengths, as detailed in the foregoing notes—1 in 40, 2 in 40, 4 in 40.

2. *Concentrated infusion of leaf.*

Powdered leaf	8 oz.
Sp. viu. rect.	2½ oz.
Aqua chloroformi	ad 12 oz.

Make up to 12 oz. with aqua chloroformi after a week's percolation and straining off liquid. *Dose:* Half to one ounce every four hours. Found as good as leaf infusions (1).

3. *Fresh stem bark extract.*

Ground bark	4½ oz.
Sp. vin. rect.	6 oz.
Aqua chloroformi	ad 30 oz.

Percolate for a week, and make up liquid with aqua chloroformi to 30 oz. *Dose:* Four to six teaspoonfuls every four hours. Found about as effective as leaf infusions (1).

DILATATION OF THE HEART.

BY

D. W. SAMWAYS, M.D., D.Sc., M.R.C.P.,

MENTONE, FRANCE.

THE mechanical disadvantages under which a dilated heart labours are not likely to be adequately realized till the influence of size on the working conditions of the heart is more fully grasped. The heart is commonly thought of as so much muscle, better or worse nourished, and better or worse controlled; whereas the factor of the size of the chamber it encloses is largely overlooked, though of immense importance to its working.

Now, if four lines be drawn from the centre of two concentric spherical surfaces through both surfaces, as in the diagram, the diameter of one sphere being double that of the other, the area enclosed between the points of passage of the first surface will obviously be but one-quarter of that for the second.

If a sphere dilate, therefore, to twice its diameter or radius, it would have an internal surface area four times as large as before, and its walls, to cover that greater surface, would necessarily become four times as thin. It

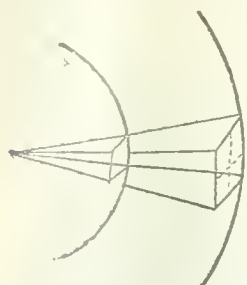

may be objected that the heart is not a sphere; the same principle, however, applies, so that if the heart were dilated to double its diameter its inner surface would be approximately four times as large, and the heart walls four times as thin. For this reason alone it would be roughly four times as difficult for the heart to contract on its contained blood, there being four times the area of blood to contract on, or four times the

number of units of area of blood to resist its contraction.

This, however, is not the whole difficulty, for the heart's power of exerting a pressure on its contents becomes halved when its diameter is doubled, so that while the work to be done is quadrupled, the working power is halved, or, in other words, the heart's embarrassments are increased eightfold.

The proof that the working power of the heart is thus lowered may be presented as follows: The force with which a hollow rubber or muscular sphere can contract on its contents is merely the force with which one-half of the sphere can pull the other half towards itself, and is measured by the pull across any circumference.

If p = the pull of a unit of muscle;

.. c = the length of circumference, which is $2\pi r$, where r is the radius;

.. t = the thickness of muscle at the circumference;

then pct = the pull across the whole circumference drawing the two halves of the hollow sphere together, and so compressing its contents.

Now pct is the same as $p2\pi rt$, but I have already pointed out that t , the thickness, becomes four times less when r , the radius, is doubled.

When, therefore, the sphere is doubled in radius or diameter the pull across the circumference is doubled in virtue of the circumference being double as long, but it is one-quarter in strength in view of the fact that the muscular material is only one-quarter as thick. On the whole, therefore, the pull is halved.

If the sphere were further dilated, say to three times its former radius, the pull would amount to $p2\pi 3r\frac{t}{9}$, or, in other words, it would gain threefold by the increase in circumference, and lose ninefold by the decrease in thickness, since the thickness decreases inversely as the square of the radius, as already shown.

Though the heart is not a true sphere it is a hollow roundish viscus, and, in its measure, is subject to the same physical principles. When enlarged it has more units of surface of blood, increasing, more or less, as the square of the diameter to resist its pressure; and it has less power to contract, the power changing in inverse ratio to the diameter.

From these two causes combined, the compression the heart can exert on its contents would decrease eightfold if the diameter of its chamber were doubled, and twenty-sevenfold if the diameter were trebled—that is, it varies always inversely as the cube of the diameter or radius.

As applied to the heart or any hollow viscus in the body, such as the bladder or uterus, these figures must not be taken as of any definite value, other than showing a physical principle to which they are subject, and the immense mechanical drawback of dilatation.

This consideration shows why "breaking the waters" when delivery is well advanced is followed by such powerful contractions on the foetus. It is quite likely that the contractions are no more powerful than before, but merely more efficient. The surface to contract on is smaller, and the two halves of the uterus can be drawn towards one another with more force, simply because the uterus is thickened. With less to contract on and a thicker contracting wall no increased muscular effort is required to produce an enormously increased expulsive effect, the pressure on the foetus could, more or less, rise inversely as the cube of the decrease in diameter.

A dilated heart may be greatly relieved by blood-letting, because it allows the distended ventricle to contract; and, once contracted, the muscle wall may, at least for a while, prevent its chamber from becoming over-large again, for it is much easier to keep a chamber small than to reduce it when once large.

I have endeavoured to show in many papers in the BRITISH MEDICAL JOURNAL and elsewhere, in the past, that the same physical principle applied to the auricle probably explains most that is puzzling in the behaviour of the heart in mitral stenosis. The presystolic crescendo murmur and its running up to and into the first sound, the absence of ventricular regurgitation through an incompetent mitral valve, the presence of regurgitation and a systolic murmur replacing the presystolic when the auricle later on dilates and allows regurgitation into it, and so on.

The important thing, however, to first realize is that the size of the cardiac chamber at any time determines, more than is readily imagined possible, the power of the heart to empty itself, the heart weakening, as it dilates, inversely, more or less, as the cube of the dilatation.

A STUDY OF THE PNEUMOCOCCUS AND STREPTOCOCCUS GROUPS IN THEIR RELATION TO INFLUENZA.

BY

W. R. LOGAN, M.D., F.R.C.P. EDIN.,

CLINICAL PATHOLOGIST, ROYAL INFIRMARY, EDINBURGH.

(Abstract of Report to the Medical Research Council, from the Research Laboratory of the Royal College of Physicians, Edinburgh; Professor James Ritchie, Superintendent.)

THE object of this investigation was a study of the pneumococci and streptococci from cases of epidemic influenza, firstly in their relation to the earliest stage of illness, when the infection was presumably a comparatively pure one; and, secondly, with regard to their part in the more advanced cases, when pulmonary complications had set in.

The preliminary portion of the inquiry was directed to questions of technique. It was necessary to define precisely what constitutes a pneumococcus and what a streptococcus, and what criteria may be adopted for distinguishing various types of these organisms from one another. It was concluded that, while there are various properties which, if taken together, may serve to distinguish the pneumococcus and streptococcus groups from each other, there is only one test which, if used as a single test, can serve to differentiate the two groups—the bile test. The solubility of pneumococcus in bile, apparently an empirical reaction, is nevertheless an indication of a specific chemical constitution of the pneumococcus, which it does not share with the streptococcus group. This test was then adopted as the invariable means of distinguishing the two groups, while the other tests in common use—inulin fermentation, presence of capsule, type of colony, morphology, virulence to mice, power of growth in certain media, homogeneity or granularity of growth in plain broth, etc., were used only as secondary confirmatory tests.

The methods adopted for differentiating the different types of organisms within these two groups were for the pneumococci serological, agglutination tests with the Rockefeller Types I, II, and III serums being carried out; for the streptococci, biochemical, fermentation and haemolytic tests being used.

The cases studied may be taken as typical of those occurring in the Edinburgh district during the second and third waves of the epidemic, that is, during those outbreaks which reached their height in November, 1918, and in February, 1919. One hundred and eight cases were studied completely from the point of view of their

* Advance reports on this subject have already been communicated as follows: (1) Preliminary Report to the Medical Research Committee, April, 1919; (2) Paper read before the Edinburgh Medico-Chirurgical Society, May 14th, 1919, and published by the *Edinburgh Medical Journal*, July, 1919; and (3) Paper read before the Pathological Society of Great Britain and Ireland, July, 1919; the Report (4) of which the present paper is an abstract was sent to the Medical Research Committee in April, 1920, and will be published in the *Edinburgh Medical Journal*.

pneumococci and streptococci; seventy-five were civilians, the remainder soldiers.

Specimens from cases of "pure influenza" were usually taken during the first three days of illness; from cases with pulmonary complications naturally, as a rule, at a later stage, varying from three days upwards. From the former group of cases nasopharyngeal swabs were usually employed; from the latter, sputum. Forty of these specimens were plated out direct on media suitable for pneumococcus; in the remaining sixty-eight a preliminary passage through mice with subsequent plating from heart blood and peritoneum was used along with direct plating of the specimen on suitable media.

The Incidence of Pneumococci and Streptococci in the Cases.

Pure Influenza Cases.—In this group of cases pneumococcus was isolated from 6 out of 44 cases, or from 13.6 per cent.; while streptococci were obtained from 44 out of the same 44 cases, or from 100 per cent.

Cases of Influenza with Pulmonary Complications.—From the second group of cases pneumococci were isolated from 50 out of 64 cases, that is, from 78.1 per cent.; streptococci were isolated from all the 64 cases, or 100 per cent.

It was therefore possible to draw the conclusion that the pneumococcus group played little part in the cases of pure influenza, and could therefore be excluded from the list of suspected initiating agents; that its great increase in number in the cases suffering from pulmonary complications, having in mind the known pathogenicity of many pneumococci, suggested an important rôle in these complications. It was further shown that streptococci were invariably present in both simple and complicated cases.

The next step was therefore to ascertain if these pneumococci in the secondary complications were of one type, and similarly if the streptococci of the simple and complicated cases differed on the one hand from each other, and on the other hand from the streptococci normally inhabiting the mouths of human beings.

Types of Pneumococci Present.—Fifty-one strains of bile soluble diplococci from 34 cases of influenza were typed out, using Rockefeller I, II and III serums. Of these 34 cases three yielded Type I pneumococcus, three Type II pneumococcus, two Type III pneumococcus, and 26 pneumococci of Group IV. An attempt was made further to subdivide the Group IV pneumococci with the object of determining whether those present in influenza were or were not the same as those sometimes obtained from healthy throats. The attempt was unsuccessful.

Types of Pneumococci in relation to Types of Clinical Case.—The eight strains of Types I, II and III pneumococci were, with one technical exception, derived from cases with well-marked pulmonary involvement, in each case with consolidation, shown either clinically or at *post-mortem* examination. The exception was a case of "pure influenza," showing no pulmonary symptoms at the time a Type I pneumococcus was obtained; the manifested pulmonary symptoms within a day or two and died within a week of pneumonia. One of the Type II pneumococci was from a lobar pneumonia in which the existence of influenza was doubtful.

The Group IV pneumococci were derived from cases of pure influenza; from cases of influenzal bronchitis; from cases of influenzal bronchopneumonia; and from cases in which, as shown both clinically and by *post-mortem* examination, extensive consolidation was present. They were isolated from cases in which the illness was trivial, from cases in which a very chronic chest condition supervened, and from cases with a rapidly fatal termination.

Incidence of Haemolytic and Non-Haemolytic Streptococci.

For the purpose of differentiation the action on blood agar was employed.

One hundred and nine strains of streptococci derived from 57 cases were subjected to the test. From 28 cases of pure influenza haemolytic streptococci were not once obtained; of 29 cases with pulmonary complications, 8 yielded haemolytic streptococci, or 28 per cent. of these complicated cases.

The Haemolytic Streptococci.—The same conclusion was thus arrived at with regard to the haemolytic streptococci as had been come to concerning the pneumococci; there was evidence that they played no part in the production of pure influenza, but they were apparently active as secondary invaders of the lung in more than a quarter of the cases with pulmonary complications, as compared with the figure of three-quarters of the cases obtained for the pneumococci.

The Non-Haemolytic Streptococci.—These were obtained from all the cases examined save two. In these two, haemolytic streptococci were obtained in the culture, in one from lung

substance (*post mortem*), in the other from empyema pus. Holman's classification for the non-haemolytic streptococci was adopted. Ninety strains, derived from 46 cases, were tested in this way. Seventy-seven of these were grouped as follows: *faecalis*, 0; *non-haemolyticus I*, 1; *mitis*, 44; *salivarius*, 26; *non-haemolyticus II*, 1; *non-haemolyticus III*, 0; *equinus*, 5; of the remaining 13 strains, 9 were either *mitis* or *salivarius*; 4 either *faecalis* or *non-haemolyticus I*. The 90 strains may therefore be grouped as follows: 79 were either *mitis* or *salivarius*, while 11 were of other varieties. As regards their case incidence, either *mitis* or *salivarius*, or both, were obtained from 21 out of 22 cases of pure influenza; while either *mitis* or *salivarius*, or both, were obtained from 22 out of 24 cases with pulmonary complications.

Assuming Holman's tests to be adequate for the differentiation of these organisms, one would be able to conclude that their presence in cases of influenza is not significant of an infection from without, as such types are met with in normal mouths. Evidence will be produced, which cannot be given in detail here, to show that Holman's tests are not adequate for this purpose. Taking other factors into consideration, however, the conclusion was arrived at that it was in the highest degree improbable that organisms of this group were responsible as initiating agents in the epidemic; while as to their rôle in the secondary complications, there was little doubt that some members of this group, possibly even the saprophytic varieties, played a part in the complicated cases.

Summary of Conclusions.

In this brief summary of the results obtained proof of many of the statements has necessarily been omitted; these proofs will be included in the detailed paper. Here I may add some of the main conclusions. Only the pneumococcus and streptococcus groups are dealt with.

It was shown that pneumococci and aerobic streptococci could be cleared of suspicion of acting as initiating organismal causes in the epidemics; that the pathogenic organisms of these groups which were associated with the production of pulmonary complications were of a variety of types; that many of these were definitely infections from without, while with the remainder limitations of technique prevented exact proof as to their origin being brought forward; that the presence of saprophytic streptococci and of presumably saprophytic pneumococci in the lungs of many advanced cases may be explained as a late invasion of the already diseased lung, either by the patient's own mouth organisms or by the saprophytic mouth organisms passed on from another patient, while their presence in the sputum is, in many cases, due simply to the contamination of the specimen with organisms from throat and mouth.

Both from the point of view of the history of the individual case and from that of the history of the epidemic itself, one may divide influenza into three stages: a primary stage, when the unknown infecting virus, whether it be Pfeiffer's bacillus or some other organism, is apparently acting alone, though presumably frequently accompanied by other organisms which may or may not later be able to develop a like activity; a secondary stage, when pathogenic pneumococci and streptococci are active in producing pulmonary complications, either alone or along with other pathogenic organisms; and a tertiary stage, when saprophytic mouth organisms may invade the already diseased lung.

It was shown that the type of pulmonary complication is to a considerable extent dependent on the type of pathogenic pneumococcus or streptococcus present; that pneumococci of Types I, II and III were associated, as was to be expected, with pneumonias showing definite consolidation, as were also certain of the Group IV pneumococci; that others of the Group IV pneumococci and the haemolytic streptococci were associated with complications of the bronchopneumonic and bronchitic types.

The presence of complex infections in epidemics of this kind does not imply that the original bacterial cause at the beginning of the outbreak was not a single type of micro-organism; nor does proof that the important organismal varieties are always types foreign to normal mouths and throats—are in fact infections from without—imply that the real primary agent in such epidemics may not be a temporary susceptibility, individual or general, due to causes at present unknown.

FRACTURE OF THE FIRST RIB.

BY

E. T. C. MILLIGAN, O.B.E., M.D., B.S., F.R.C.S.,
SURGEON TO DREADNOUGHT HOSPITAL, GREENWICH, AND THE
WEIR HOSPITAL, BALHAM.

AND

R. E. FORD, M.B., B.S., SHEFF. AND LOND.,
HOUSE-SURGEON, WEIR HOSPITAL, BALHAM.

THE following case of fracture of the first rib is interesting, both on account of its rarity and its clinical similarity to a cervical rib or exostosis.

A female, aged 17 years, complained of a swelling in the right side of the neck. The patient was unaware of its presence until it was noticed first by another girl. She had had "pins and needles" in the right hand and a cramp in the arm for some time, and attributed this to an accident two months earlier, when she fell down a few stairs. She did not remember her attitude in falling, nor did she notice pain, tenderness, or bruising. The cramp was felt when the arm was hanging by the side, and was relieved by rubbing.

Examination showed a hard bony swelling, 1 in. above the middle of the right clavicle, fixed and irregular but somewhat rounded in cut line, about the size of a walnut. It was continuous, both in front and behind, with the first rib, into which it merged. The space between the middle of the clavicle and the swelling was too narrow to allow the examining fingers to be inserted. There was a slight falling backwards of the anterior end of the clavicle. Between the swelling and the skin the pulsations of the subclavian artery, which was displaced upwards and outwards, could be seen and felt distinctly, giving also a thrill and bruit. The cords of the brachial plexus situated immediately behind the pulsating artery were similarly displaced, and could be rolled over the subjacent swelling with the examining fingers. The radial pulse was altered in volume and force when the arm hung by the side. Sensation and muscular power were unimpaired, and there was no wasting. Fracture was confirmed by x-ray examination.

The unique features of this case are the displacement and the clinical signs and symptoms.

Displacement in fracture of the first rib is quite rare. In the case recorded displacement was the main feature, attracting the notice of others to the swelling in the neck, and causing pressure signs and symptoms. In the literature there is an instance of slight displacement causing the normal curve of the rib to be slightly angular. If it is remembered that the first rib has superior and inferior surfaces with internal and external borders, it can be seen that angular displacement would more likely be upwards or downwards than outwards, which is the case in other ribs with internal and external surfaces and superior and inferior borders.

Complications usually draw attention to the fracture hitherto unnoticed, so that probably the frequency of complications has been exaggerated, uncomplicated fractures being no doubt overlooked. Abscesses above and below the clavicle have required incision and drainage. Empyema, lung abscesses, even rupture of the pleura and lung, followed by death, have occurred as complications. The case now reported is unique in its relation to the subclavian artery, which with the brachial plexus is displaced upwards and outwards.

Site of Fracture.—Fracture at the site of injury occurs by direct violence applied to the posterior and also to the anterior part of the first rib. These areas are protected by the posterior shoulder girdle muscles and the inner end of the clavicle respectively, so that great violence is needed to cause fracture. The costal cartilage and junction of the costal cartilage with the first rib have also been the site of fracture. Any part of the rib between its two extremities is subject to fracture, and the deformity, angulation upwards and outwards, would fairly suggest compression force applied from either end. This part of the rib is shielded from direct violence by overlying structures. It has been suggested that the clavicle might act as a powerful lever, fracturing the underlying rib, like the top lever of a nutcracker, trauma on the shoulder representing the power. This mechanism can only act very rarely, if at all, and in abnormal relations of clavicle to first rib, else fracture of the first rib would be a common occurrence, for injuries and falls on the shoulder are very frequent.

Symptoms and signs are usually so slight as to pass unnoticed, or are overshadowed by concomitant injuries. Indeed, the fracture has very often been discovered during

the investigation of its complications. Still, in a few cases localized pain on breathing, or moving the shoulder girdle or neck, has been felt.

Union is the rule, as in all ribs, yet a case has been described of pseudarthrosis at the site of fracture. In the case here reported there is firm malunion.

A CASE OF
MYOCLONIC ENCEPHALITIS LETHARGICA
SIMULATING HYDROPHOBIA.

BY

STANLEY E. DENYER, C.M.G., M.D., M.A. CAMB.,
F.R.C.S. ENG.,

PHYSICIAN, HULL ROYAL INFIRMARY,

AND

D. E. MORLEY, M.D., B.S. LOND.,

BARTON-ON-UMBER.

IN the discussion on epidemic encephalitis in 1918, at the Royal Society of Medicine, Dr. Crookshank pointed out that the old physicians used to describe "hydrophobia without the bite of a dog," and that this condition had also been reported in England in 1918. The following case was one in which hydrophobia was thought to be a possible diagnosis.

A. B., female, aged 25 years, up to the morning of November 11th, 1920, was in good health, and with the exception of three attacks of influenza had had good health for many years. On the evening of November 11th she did not feel well; on November 12th she gave up her usual occupation owing to increased feeling of illness. She was first seen by one of us (D. E. Morley) on November 13th, and appeared to be suffering from a mild influenzal attack with no special symptoms. When seen on the 14th she was distinctly excited and anxious about herself; she had vomited in the morning, and headache had become a more marked feature. On November 15th, when seen (by D. E. M.) she became, as she had been earlier in the day, maniacal. Sitting up in bed, she shouted that her mouth was paralysed and that she was going to die. The left side of the face was weak but there was no definite paralysis. On the 16th she was wildly delirious, the most marked feature being dread of trying to swallow, and the prolonged laryngeal spasm caused by the attempt to do so. The same ideas of paralysis and death still pervaded her delirium. The condition was such as one would expect to find in a case of hydrophobia, only there was no reasonable excuse for such a diagnosis.

On November 17th she had subsided into a semi-comatose condition and was seen in consultation (with S. E. Denyer). Encephalitis lethargica was diagnosed. The condition found (by S. E. D.) was as follows: Temp. rect. 100°, pulse 88, good; limbs flaccid, no trismus, slight twitching of the facial muscles on the right side, pointing to irritation of the seventh cranial nerve. She also had occasional clonic movements of her arms. The knee-jerks were present, no Babinski, no ankle clonus, tend. Achilles jerks not obtainable, no Kernig's sign. On stroking the foot fairly hard, irregular twitching of the muscles of the outer side of the thigh took place. There had been no incontinence of urine or faeces until this day, when there was a slight incontinence of urine; the bladder was empty. Pupils react to light but are unequal, the left being slightly dilated. No nystagmus. She was in a lethargic state and did not answer questions or appear to be aware of anything that was going on. There was great difficulty in swallowing, owing to the marked laryngeal spasm. A fluid of purulent appearance was frequently regurgitated from the throat. There was subcutaneous emphysema at the root of the neck on the right side. *Tache cérébrale* was present. The abdominal superficial reflex was present. There was no squint or ocular paralysis, reflex was present. There was no retraction of the head or no cyanosis, no sweating, no rash, no retraction of the head or no pain in moving the neck in any direction. She had been fed successfully with a nasal tube previously, but an attempt to repeat this set up a condition of spasm which made feeding impossible by this means. She was therefore given saline enemata containing sugar, and to these was added 40 grains of hexamine every eight hours.

This treatment was continued, and on November 19th 10 grains of hexamine was administered intravenously. On November 20th she was conscious, and a further 20 grains of hexamine was given intravenously. On November 21st she was much improved mentally, being conscious of her surroundings and able to speak sensibly, though her words were incompletely formed. Feeding now became possible by a stomach tube, though there was still considerable spasm until the tube was in position. Her general condition, however, became worse, and although the emphysema at the root of the neck which had been so marked on November 17th had completely gone, bronchopneumonia supervened and the illness terminated fatally on November 24th.

The temperature varied from 100° to 102°, with the exception of rises to 104° and 105° on the third and fourth days of the illness.

The indications seemed to point to hexamine being of value. The cause of death seemed to be the result of the rupture of one of the constrictor muscles of the pharynx, due to extreme spasm, causing subcutaneous emphysema, with resulting cellulitis and aspiration pneumonia.

Memoranda:

MEDICAL, SURGICAL, OBSTETRICAL.

CARDIAC MASSAGE IN RESUSCITATION.

PROFESSOR GUNN'S most interesting article on "Massage of the heart and resuscitation," in your issue of January 1st, 1921, leads me to think that it will be of interest to record a case which supplements his experimental findings by some clinical observations.

An adult female, suffering from carious teeth. General anaesthesia was induced with ethyl chloride, and three teeth were extracted without difficulty. Cessation of respiration and sudden pallor immediately ensued. Ether was injected subcutaneously and artificial respiration begun. As the pallor increased, the heart was auscultated and found to have stopped. Artificial respiration was persisted in for about three minutes from the time of cessation of respiration in the hope that the cardiac inhibition would prove a temporary one, but it was of no avail. The abdomen was then opened, and cardiac massage begun. With the other hand artificial respiration was maintained by simple compression of the chest. Pituirin 1 c.cm. was given subcutaneously. Colour almost immediately returned to the face, showing the efficacy of the artificial circulation. After about five minutes' massage, feeble spontaneous heart beats were felt, and were supplemented at intervals by massage. About two minutes later several deep spontaneous respirations were made in rapid succession. This was at once followed by arrest of the heart and respiration also stopped again. Cardiac massage and artificial respiration were persisted in for forty-five minutes, during which time deep inspirations were made at intervals of about ten seconds—as in morphine poisoning. At first deep, they became shallower and more infrequent, and eventually ceased.

This case is of interest in the light of the theory which Professor Gunn has advanced. Professor Gunn suggests that certain cases of failure in resuscitation by cardiac massage and artificial respiration are due to vagus inhibition. In such a case the heart has commenced again to beat well, after massage; the paralysed central nervous system, including the respiratory and vagus centres, begins to recover; spontaneous respiration begins; then the vagus centre awakens, hyperexcitable after its paralysis, and cardiac inhibition results. From cardiac arrest due to this cause Professor Gunn states that he has been unable to resuscitate animals.

In the case described this sequence of events is closely followed. The heart was initially arrested by vagus inhibition, due to stimulation of the fifth cranial nerve. Cardiac massage and artificial respiration revived the brain. Spontaneous respirations began, immediately followed by cardiac arrest, presumably due to inhibition by the recovering vagus centre. If, as Professor Gunn recommends, atropine had been administered intravenously, it seems probable that this patient would have recovered.

Edinburgh.

NORMAN M. DOTT, M.B., Ch.B. Edin.

A CASE OF DELAYED ARSENICAL POISONING.

The length of time (three months) which elapsed from the taking of arsenic to the fatal result, the large quantity taken, and the nature of the symptoms in the slow poisoning of the nerve tissues, all make this case of interest from a medico-legal point of view, though the taking of the drug was purely accidental, and not the slightest suspicion of attempted suicide ever arose.

Mr. X., aged 68, proprietor of a grocery establishment, who carried on also an extensive pharmacy, had been under my care for some time, suffering from enfeebled action of the heart, but not sufficient to prevent him from following his usual business. At 8 p.m. on February 23rd, 1920, he took by mistake for a preparation of magnesia, which he was in the habit of taking for indigestion, a heaped teaspoonful of arsenic mixed with hot milk; the quantity when weighed equalled 180 gr. Half an hour later he ate a hearty supper of porridge and milk. At midnight he began to vomit, had diarrhoea, and complained of a burning sensation in his stomach. The diarrhoea and straining continued with increased violence

until 3 a.m. When I arrived at 4 a.m. I found him cold, with thready rapid pulse. He was vomiting, and had watery diarrhoea with great tenesmus. Water was at once rejected; the temperature was subnormal, and the pulse 120. He complained most of cramps in his legs and intestines, and a burning feeling in the pit of the stomach, with vomiting and diarrhoea every few minutes. He was quite conscious, and wrote an account of how the accident occurred. I decided with Dr. D. C. Campbell, who had arrived also, that it would be useless to wash out the stomach now, but to relieve pain and restrain the diarrhoea and tenesmus we gave him an enema of a drachm of tincture of opium and one of starch. This relieved these symptoms and the cramps in the legs. He was given albumin water by the mouth during the rest of the night, and then milk and barley water. There was only one motion of the bowels, and this not until late in the evening. When next seen, about 10 a.m., the temperature was normal, and the pulse 100. He was very restless, and complained of fidgets in the legs but no cramps. The conjunctivae of both eyes were slightly congested. No urine was secreted; a rubber catheter was passed, but no urine was found in the bladder. He was then seen by Dr. H. McKisack, and diuretics were ordered, with mustard and linseed poultices to the loins in order to encourage the action of the kidneys and assist in the elimination of the poison. Magnesium sulphate was also given freely. This had the desired effect, and urine was freely passed. The patient was now able to be up and about, and soon was walking in his garden; eventually he even walked down to my house.

The first untoward symptom that showed itself was a feeling of pain in both arms and forearms which he compared to neuralgia, for which he was given phenacetin and aspirin, with massage. This increased to a feeling of numbness in the parts supplied by the radial nerves of both hands, so that he was unable to hold a cup or spoon firmly, but he was still able to walk. Dr. McKisack, who again saw him with me, suggested in addition to the potassium iodide which he was now taking, and the massage, that he should have a continuous current applied, and for this reason he was removed to a nursing home in Belfast on April 30th. He was then able to walk, but said his feet felt as if he were walking on wool. Very soon after he was brought there he was found to be ataxic in his gait; he was unable to stand upright if his eyes were closed, or to make an attempt to walk if his eyes were closed without falling. The knee jerks gradually became lost and ankle clonus appeared. He became slowly but steadily worse, hypostatic pneumonia developed, and death took place on June 13th by slowly ascending paralysis. Up to the end arsenic could be found in the urine.

GEORGE ST GEORGE, M.R.C.P.I., L.R.C.S. Edin.,
Surgeon, County Antrim Infirmary, Lisburn.

A TUMOUR OF THE NECK.

THE following case may be of interest, especially from a diagnostic point of view:

Mrs. W. was admitted to the Wakefield Hospital in March, 1920. For five years she had suffered from an enlarged tonsil (right). At intervals she had acute attacks accompanied by pain and increased difficulty in swallowing, which subsided after the discharge of pus. It was ascertained afterwards that the pus came, not from the tonsil, but from the ear. Recently the tonsil had become larger, and the swelling appeared under the lobule of the ear, and another in the submaxillary region.

On examination, there was a swelling about the size of a chestnut just below the lobule of the ear, which seemed to fluctuate. There was another similar swelling in the submaxillary region. The mouth could be opened easily, and the so-called enlarged tonsil was seen to project from between the pillars of the fauces and extend across the pharynx, leaving only a small space on the left side for the passage of food. The mucous membrane covering it was of normal colour, and palpation of it caused no discomfort.

A curvilinear incision was made behind the angle of the jaw, revealing almost immediately a solid tumour which proved to be the size of a duck's egg, and of similar shape, except where an outgrowth, softer than the rest of the tumour, passed outwards towards the lobule of the ear. The tumour was shelled out with ease, save perhaps where various seekers after pus had pursued their vigorous

investigations. On the outer pole was the attenuated submaxillary gland, and on the inner a trophic tonsil. Microscopic examination of the tumour showed the presence of fibrous tissue, cartilage, muscle, fat and some epithelial elements. Recovery was uneventful.

Wakefield.

J. W. THOMSON.

Reports of Societies.

ADVANCING YEARS AND BALNEOTHERAPY.

SENESCENCE in general and from the balneotherapist's point of view was the subject of Dr. G. L. PARDINGTON'S presidential address delivered to the Section of Balneology and Climatology of the Royal Society of Medicine on January 27th. After a concise survey of the atrophic and degenerative changes which made their appearance with advancing years, he said that for the maintenance of physiological equilibrium and the prevention of functional failure, or its anticipation and the limitation of its effects, reliance must be placed on hygiene in the widest sense, including regulation of diet, methods of living, work, rest, and exercise. It was here that balneotherapy found one of its most effective uses. Balneotherapy he defined as the application to the body surface of thermal and mechanical stimuli by means of water, air, or rays of incandescent light; the effects of such stimuli varied with the temperature, duration of application, area involved, technique, and condition of the patient. The first four of these factors were under the physician's control, and the fifth called for his careful supervision.

The temperature of the skin, Dr. Pardington continued, averaged about 90° F., which point formed the zero of thermal stimulation. It might be that the effects of stimuli within the range from 78° to 98° differed specifically as well as thermally from those beyond either extreme. The duration of any balneotherapeutic procedure should vary inversely with the intensity of the thermo-stimulation, and this applied especially to the lower ranges of temperature. A few seconds would suffice for decidedly cold or hot applications, except in local measures such as douches, where mechanical effects were superadded. The duration of moderately hot or cold applications might be measured in minutes, while the neutral bath (95°) might be employed for half an hour for a general sedative effect. Generally speaking, those cutaneous areas which had the best vascular supply yielded the best response to cold applications. Precision in details of administration influenced very largely the attainment of the desired result. The bath chamber should be well ventilated and warmed to 75°. In measures involving percussion and vibration it was important that the force of water should be adequate—some 20 or 30 lb. to the square inch. A careful estimate should be made of the condition of the patient, more especially with reference to the cardio-vascular apparatus, the blood pressure, the possible existence of anaemia, and the state of lungs, kidneys, and excretory organs. Individual predisposition as well as age had to be considered.

Dr. Pardington then discussed indications and results. The effect of a cold general application was a contraction of the peripheral vessels of the skin and a general reduction in surface temperature. The effect on the peripheral terminations of the sensory nerves resulted in a powerful stimulation of the central nervous system. The respiratory centre was very largely stimulated, and the respirations after the initial shock were temporarily quickened. The pulse was also quickened and the blood pressure raised. Afterwards the reaction occurred, and the feeling of chilliness was succeeded by warmth and exhilaration. This was the expression of physiological resistance, and its complete attainment was the object to be aimed at in all general tonic measures. It was necessary to be alive to the possibility of untoward results, such as deficient reaction, indicated by pallor, coldness of skin and extremities, faintness, and giddiness, which called for hot drink and warm clothing; and excessive reaction, shown by over-excitation of the heart, throbbing headache, and profuse sweating, which might be met by a general cold application (from 80° to 65°). Such untoward reactions might be encountered immediately, but there were other manifestations more remote, such as

excessive tissue change, indicated by loss of weight, strength, and appetite, and by dyspnoea, which was generally due to some overlooked asthmatic affection. Cold tonic measures were usually best for the disordered metabolism which was often the initial phase in the disturbed conditions observed in advancing years, but such applications must be carefully graduated. The needle bath was one of the most useful means of treatment, as it could be regulated in temperature and duration with the utmost nicety. Where there was any tendency to cardio-vascular change extremes of all kinds were to be specially avoided, and tentative procedure was called for. Phlegmatic persons tolerated very well douches under suitable pressure. The sedentary were benefited by sudoriparous measures as well as by cold tonic treatment. The painful and stiff joints due to senile changes were much benefited by heat packs followed by cold douches. Turkish and Russian baths, especially the latter, were unsuitable in advancing years, particularly in the case of those unaccustomed to them, and all the advantages of such measures could be got equally well by hot air or vapour cabinet baths, or, better still, electric light cabinet baths. Baths of indifferent temperature (95°) were of special importance in senescence, especially in conditions of nerve irritability and insomnia, provided that reaction was carefully guarded against.

Dr. Pardington said, in conclusion, that he had been brought into contact with many people well advanced in years, some of them quite old, who had impressed him by their unusual vitality. They were people who had availed themselves regularly of a balneological course of treatment. Their vigour and alertness both of body and mind might be attributed to a lifelong observance of all the physiological commandments, but he knew that in the case of some of them this was not so, and he had been forced to the conclusion that balneology explained to a large extent their high standard of health. It was the case of these valetudinarian veterans which had suggested the theme of his address.

TESTICULAR DISEASE FOLLOWING TRAUMA.

At a meeting of the Medico-Chirurgical Society of Edinburgh on January 19th, Emeritus Professor F. M. CAIRD presiding, Mr. CHARLES W. CATHCART read a paper on epididymitis and orchitis from muscular strain, followed by tuberculosis of the epididymis. The problem was twofold: First, could a severe muscular strain of the abdominal wall set up acute epididymitis and orchitis; and secondly, could this acute inflammation excite sub-acute tuberculosis of the affected parts? The following case from his own experience was typical, and was both of surgical and medico-legal interest.

A young miner, aged 21, and previously in perfect health, strained himself in attempting to lift a heavy weight. At once there was sharp pain in the lower abdomen on the left side, and very soon a "gripping" pain in the left testicle, associated later with nausea. He then noticed himself that the scrotum was swollen and reddened, and this was confirmed by his doctor a few hours later. Some days later the left testicle was found to be swollen and tender, this subsiding in a few days. But two weeks later pain returned very severely, swelling increased, and after a month an abscess was raised, which was found to be due to a tuberculous epididymis.

Mr. Cathcart reviewed fourteen similar cases from the literature and from private records. In some of these there was passage of blood per urethram; but in most this was absent. The effects on testicle and epididymis varied—in some a transient swelling, in others subsequent atrophy or chronic inflammation. It seemed clear that a simple muscular strain could produce such injuries, and that they were analogous to the strains and ruptures of ligaments and muscles, and to the sudden hernias, of healthy people. As to the mechanism of production of the lesion there were two theories. Hilton's view was that there was a rupture of the vas deferens; while the view of Bartholomew and others was that torsion of the vas took place, and this could account for all the symptoms, including that of urethral bleeding. The speaker on the whole favoured the "torsion" theory in the majority of such cases. In Lapointe's 34 cases of torsion of the vas deferens there was no history of trauma or effort in 6; while in 19 there was some strong sudden contraction of the abdominal muscles. The variation in the symptoms as to rapidity of

onset, severity, and after-results was explained by the varying degrees of torsion, and by its duration or permanency. It did not seem unreasonable to suppose that a latent or new tuberculous process might be set up in the damaged epididymis. Mr. Cathcart summarized his views on the subject as follows: Acute orchitis and epididymitis might be caused by a severe abdominal strain, and in the absence of any previous infection—for example, gonococcal—of the urethra, and without any apparent abnormality of the testicle. This acute inflammation was, at least in some cases, the result of torsion of the cord induced by the strain and due to vigorous or irregular contraction of the cremaster muscle. In other cases the inflammation might be due to rupture of the vas deferens, with simultaneous injury to the vessels and nerves of the cord. The acute process might end in atrophy or chronic inflammation of the testicle or in local tuberculosis.

Emeritus Professor CAIRD quoted several cases of this kind where operation had been done; in all torsion of the cord was present. The complication of tuberculosis was analogous to tubercle following a sprained ankle.

Vaccine Therapy in General Practice.

Dr. R. ROBERTSON subsequently read a paper detailing the use of vaccines in various acute and chronic bacterial infections. In boils, and most septic infections of the skin, the disease was cured after three or four injections if the correct technique was practised, and stock vaccines seemed to do as well as autogenous. Occasional failures here were due to the overlooking of some other infection. Common colds, caused by *Micrococcus catarrhalis* with associated staphylococci and streptococci, and frequently also *Bacillus influenzae*, were very amenable to vaccine treatment. With such a mixed vaccine, if the site of injection became painful in twenty-four to forty-eight hours, this made it very probable that *M. catarrhalis* was the cause of the condition. Sciatica and neuritis in 90 per cent. of cases were of rheumatic origin, and usually yielded quickly to a streptococcal vaccine; as also did many cases of tonsillitis. Chronic pharyngeal catarrh did well with mixed streptococcal and staphylococcal vaccines, but required about twelve injections. Colds in the head were sometimes obstinate, and in such cases further examination might show a local diseased condition requiring surgical treatment. In otitis media and frontal sinusitis complicating influenza, good results could be got with a stock catarrh vaccine, beginning with small doses; but he advised autogenous vaccines in these conditions. For erysipelas, he had used mixed staphylococcal-streptococcal vaccine with very good results, the condition clearing up in one week as a rule. As to pneumonia, he warmly advocated the use of vaccine; he believed that, if used at the outset, there was complete abortion of the attack in 25 per cent. of cases. He usually gave 20 to 25 million for the first dose, but this depended on several factors—duration of attack, severity of symptoms, etc. Sometimes the effect was marvellous, and lantern slides were shown demonstrating the changes in temperature, pulse, and respiration. As to tuberculin treatment, it required to be continued for two or three years. Cases of intestinal dyspepsia, especially acute cases with diarrhoea and flatulent distension, were suitable for vaccine treatment. Neurasthenia, where there was so often severe chronic intestinal dyspepsia, also came under this category.

Dr. R. A. FLEMING, as the result of his experience in the great influenza epidemics of 1918 and 1919, was sceptical as to the value of vaccine in pneumonia. An autogenous vaccine might do better, but the delay in its preparation was a handicap. He had had good results with Béranek's tuberculin. In bronchiectasis a carefully prepared autogenous vaccine sometimes worked wonders.

Dr. CHALMERS WATSON said there was a psychic factor in the use of all vaccines which might account for part of their benefit. Mr. WILKIE agreed as to the value of vaccines in preventive medicine and certain chronic diseases, but he required a fuller demonstration to be convinced of their value in some of the acute diseases. Mr. J. S. FRASER said he had used vaccines in a sporting spirit, and he was cautious in prophesying results. They had not been much help to him in accessory sinus affections where the drainage was the important thing. Sometimes, indeed, there was a striking success; but just as often the results were very disappointing.

ANAESTHESIA AND POST-OPERATIVE MORBIDITY.

At a meeting of the Scottish Society of Anaesthetists, held on December 4th, 1920, at the North British Hotel, Edinburgh, Dr. TORRANCE THOMSON read his inaugural presidential address on the subject of "Post-operative morbidity in relation to general anaesthesia." Although many conditions falling into the category named were not directly under the control of the anaesthetist, it was essential that he should be fully acquainted with the literature and current theories of the subject, so that he might play his part in securing improved results. Recent work was reviewed under the three headings: (1) Nausea and vomiting; (2) chest complications; (3) shock.

In regard to (1), recent work did point to some connexion between diminution of alkali reserve and after-vomiting, but that was not the whole problem. The use, when possible, of nitrous oxide-oxygen, smooth administration of the least possible quantity of anaesthetic, and gentleness of manipulation on the part of the surgeon, were all factors. On the whole, Dr. Thomson favoured the preliminary use both of narcotics in moderate doses and of alkalis. Under (2), he thought that skilful administration was of more importance than the mere choice of anaesthetic. In cases of so-called ether bronchitis or pneumonia he thought the patient usually had a pre-existing catarrh, a point too little recognized by surgeons. Prevention of skin-chilling during operation and during transit back to bed also demanded careful attention. The warming of anaesthetic vapours might diminish local irritation of air passages, but its effects on after-results were not proved so far as prevention of respiratory complications was concerned. Under heading (3) the work and literature of the war had shown some connexion between acidosis, falling blood pressure, and clinical shock. It was, however, in cases showing marked diminution before operation that the connexion seemed closest. From the anaesthetist's point of view such cases should be given gas-oxygen. The practical difficulties in this were the lack of proper plant in many hospitals, the cost and trouble of transporting the apparatus in private work, which would involve raising the standard of remuneration for anaesthetic work.

Summing up the whole question, Dr. Thomson thought that the essentials in the prevention of complications under all the headings were: (a) That anaesthesia should never be pushed to a degree greater than was absolutely essential, and that in this respect the surgeon should learn not to be too exacting; (b) that Crile's pre-operative anti-emotional technique should be carried out as far as possible; (c) that excess in fasting and purgation should be avoided; (d) that alkalis and a moderate dose of narcotic should be given before operation.

A general discussion followed. Dr. H. P. FAIRLIE referred in particular to post-anaesthetic vomiting:

He was glad to hear a warning regarding the excessive starvation and purgation so often prescribed before the administration of an anaesthetic; he agreed that they tended rather to encourage than to prevent post-anaesthetic vomiting. He mentioned a measure advocated by the late Dr. Rentou—namely, the placing of the patient in the sitting posture after operation. Whenever feasible, it rendered vomiting less likely to occur, and less objectionable when it did occur. The use of preliminary atropine helped in the prevention of vomiting and shock, and of post-anaesthetic bronchitis, by diminishing the secretions in the mouth which were so liable to be swallowed and inhaled, acting then as an irritant. With reference to the employment of gas and oxygen, he found, with considerable experience of this anaesthetic, that it was open to most of the criticisms which had been levelled at it by various speakers at the meeting—for example, it was expensive, it required a bulky outfit, and it required, especially for abdominal operations, the addition of ether. But he agreed with Dr. Thomson that in many operations it was a most valuable anaesthetic. It was safe, it diminished shock, it left the patient in a much happier state than ether or chloroform, the sickness following anaesthesia being much less frequent and less severe after gas and oxygen than after either of the other anaesthetics.

The following cases of interest were recorded:—

Dr. TORRANCE THOMSON: A 10-days-old child anaesthetized by chloroform—open ether for an operation of a few minutes only. No incident of note occurred during the operation, but the child died suddenly ten days later, and *post mortem* very marked status lymphaticus was found.

Dr. LAMB mentioned a case of secondary syncope after breathing during an induction by chloroform of a woman. The breathing began again after the use of artificial respiration, and persisted for forty minutes although there was no pulse, and with the exception of the chest movement the patient was apparently dead. Dr. ROSS said he had seen something of the same in a dog, but never in a human being, nor had he seen the condition persist for more than a minute or two.

Dr. JOHNSTON recorded the case of a woman who had a Pou's

fracture reduced under nitrous oxide, and who died ten minutes after recovery from the anaesthetic. On post-mortem examination there was thrombosis in the femoral artery and vein of the affected limb, and an embolus in the pulmonary artery.

THE annual meeting of the North of England Obstetrical and Gynaecological Society was held at Manchester on January 21st. Mr. CARLTON OLDFIELD (Leeds) was elected President for the ensuing year. Dr. BRIGGS (Liverpool) showed a specimen of tuberculous salpingitis removed from a patient thirteen years previously; she was now in perfect health. He was of opinion that inflamed tubes were more commonly tuberculous than was usually supposed. Dr. W. W. KING (Sheffield) showed a specimen of hydrometra removed from a nulliparous patient. The uterus was the size of a four months pregnancy and the obstruction to the outlet of uterine secretions was caused by a small cyst arising in the mucosa of the cervical canal. Dr. CLIFFORD (Manchester) showed a large ovarian tumour removed from a girl aged 12 years. The growth was a sarcoma of rapid growth with extensive areas of necrosis. Dr. SHAW (Manchester) described a case where he had removed a large myxomatous tumour of the left ovary, the other ovary being at the time apparently quite healthy. Twelve months later the patient returned with a large abdominal tumour which, at operation, proved to be a similar growth of the right ovary. Dr. LACEY (Manchester) read a paper on induction of labour for contracted pelvis, based on a series of 75 cases, in which the conjugata vera measured not less than $3\frac{1}{2}$ in. in flat nor $3\frac{3}{4}$ in. in generally contracted pelvis. The method adopted was that of Krause, but this was supplemented in 29 instances by the introduction of a Champetier de Ribes's bag. The maternal mortality was, of course, nil; the morbidity 1.3 per cent.; 84 per cent. of the children were born alive, and of these, 78.6 were discharged well on or about the twelfth day.

Revielus.

GROWTH AND SHEDDING OF ANTLERS.

IS his beautifully illustrated monograph on *The Growth and Shedding of the Antler of the Deer*, which describes in detail the histological phenomena and their relation to the growth of bone, Sir WILLIAM MACWEN,¹ Regius Professor of Surgery in the University of Glasgow, presents us with a full account of the results of a prolonged inquiry. He was no doubt attracted to this subject by his well known interest in the development of bone, and further light is thrown on this problem. The quantity of osseous matter secreted annually to form the antlers of the larger deer is enormous, and was stated by the late Sir William Flower to have been in certain instances more than that of all the bones of the skeleton put together. As the growth of the antler proceeds from a single comparatively small centre of ossification in the frontal bone, the cellular proliferation is in excess of that seen not only in any normal process, but also in the most rapidly growing tumours. The growth of the antler is in some respects analogous to that of bone which follows amputation through the arm or thigh of a child, ultimately forming a conical stump as a result of continuous proliferation at the proximal epiphysis; but the antler has a tip of actively proliferating cartilage, and is covered by the velvet—a remarkably complete reproduction of the skin with its glands, nerves, vessels, hair follicles, and appendages.

The evolution of the osteoblast is illustrated by most successful photomicrographs, and the syncytium, from which bone and cartilage develop, is shown to be alike in the antler of the deer, in bone grown experimentally in glass tubes, in dog's bone, in human growth, and in the regeneration of bone, such as in repair after osteomyelitis and in the healing of fractures. The separation of the antler depends primarily on the withdrawal of its blood supply and is an aseptic process. The concluding chapter is devoted to the phenomenon of nuclear budding observed in osteoblasts that have reached or are approaching their mature form; since it has been seen in deer's antlers it has been detected near the growing epiphyses in the dog and in man, as well as in morbid processes attended by rapid growth, such as sarcoma. The check to the growth

of the antler produced by castration probably involves among other changes, cessation of nuclear budding.

When regarded from the evolutionary point of view the stag's antlers are a great puzzle. It is not easy to see that they serve any purpose which, even if they grew once for all, would be commensurate to the expenditure of energy and material: as the antlers are shed annually the puzzle becomes greater. So far as we are aware there is nothing comparable in nature. We have dwelt upon the histological side of Sir William Macwen's book, but it will interest all those concerned in natural history, whether as naturalists or sportsmen.

A FRENCH SYSTEM OF MEDICINE.

A NEW treatise on medicine,² produced under the distinguished editorship of Professors ROGER, WIDAL, and TEISSIER, promises to constitute a landmark in the annals of the medical literature not only of France, but of the world in general. The list of collaborators whose services have been secured to contribute to this great system of medicine includes all those living Frenchmen whose work and opinions we hold in highest esteem.

In 1891 the classical system of Charcot, Bouchard, and Brissard appeared, and presented a wonderful collection of monographs and original memoirs on the whole domain of medicine. About 1912 Bouchard considered the time had come for a new edition or rather a new treatise. He turned therefore to his old pupils Roger, Vidal, and Teissier, to undertake the direction of the new work, which was to embody as far as possible the whole contributions of modern France to medical progress. It is difficult to realize fully how extensive and important those contributions have been during recent years, but on reading through the list of contributors to the new treatise we do at least recognize that nearly all the names sound as familiar and famous in England as in their own country.

The treatise is to consist of twenty-one parts or fasciculi, each of which will be almost a complete book in itself on some branch of medicine.

The first fasciculus is one of three, or, more correctly, of five, which are to deal with infectious diseases and diseases due to parasites. Roger introduces the subject with a section on infection in a general sense. He classifies and describes the various infective agents, giving brief accounts of the biological characters and their effects in man and in animals. We say particularly "and in animals" because it is evident that France enjoys a peculiar heritage from the work of Pasteur—namely, that the study of comparative medicine is regarded as part and parcel of the study of disease in man; whereby the health of man and animal alike will, we believe, profit incalculably. Other subjects dealt with in the first fasciculus are septicæmias by E. Saequépée, streptococcal infections by Roger, pneumococcal infections and pneumonia by Menetrier and Stévenin, and infections from staphylococcus, tetrigena, enterococcus, Pfeiffer's bacillus, and Friedlander's bacillus, as well as psittacosis and proteus infections by H. Macaigne. A. Veillon writes on putrid and gangrenous infections, Dopter on the meningococcus, and Hudelo on gonococcal infections.

This book is particularly welcome because it sets once and for all an example of the way to combine in a single description the pathologist's and the clinician's view of a disease. This is admirably illustrated in Dopter's account of meningococcal infections. French medicine is to be envied for this capacity of either making physicians pathologists or keeping pathologists still physicians. No small part of the credit for this is due to Pasteur and to the Pasteur Institute, which discovered the secret of attracting such men as Metchnikoff, Duclaux, Roux, and Calmette.

This we believe to be the influence which is inspiring medicine in France at the present day and giving it its undoubted eminence. It would be hard to equal, from all the world beside, a list of contemporary pioneers in medicine like theirs, which includes Richet and Portier with their work on anaphylaxis, Bordet and Gengou on agglutination, Vidal on cytodiagnosis, Pierre Marie, who first described acromegaly and has added much else to our knowledge of nervous diseases; Babinski, Chauffard,

¹ *The Growth and Shedding of the Antler of the Deer*. By Sir William Macwen, F.R.S. Glasgow: MacLachlan, Jackson and Co. 1920. (Dentey 8vo, pp. 126; 103 figures, 10s. 6d., net.)

² *Nouveau Traité de Médecine*. Fascicule I, Maladies Infectieuses. Editors: Professors Roger, Vidal, and Teissier. Paris: Masson et Co. 1920. (Sup. roy. 8vo, pp. 439; illustrated. Fr. 35 net.)

Marcel Labbé—when one begins one scarcely knows where to stop, name after name comes back to the memory. The *Nouveau Traité de Médecine* is intended to give us the whole wealth of learning of which contemporary France is capable. From the first volume we have gained such a foretaste as gives us the keenest appetite for the rest. The publishers, Masson of Paris, have spared neither expense, pains, nor art to produce a work which, by its typography and its illustrations, may be held worthy of its subject matter.

PREVENTION OF DISEASE IN THE TROPICS.

DR. ANDREW BALFOUR'S volume, *War Against Tropical Disease*,³ contains seven papers, all of which, with one exception, have previously appeared in periodical publications. Dr. Balfour is well known as a pioneer worker in tropical medicine and hygiene, and the object he has had in compiling this volume may be gathered from the fact that he has called his papers "sermons," because, he says, "they are intended to spread that gospel of hygiene which is so important both at home and abroad."

All successful efforts at evangelization must be clothed in plain language, and, in this sense, the author has succeeded in being an evangelist. True to this mission, he insists on the fundamental truths of hygiene rather than entering upon a discussion of modern doctrine. To say, therefore, that the book contains little that is not already known to the expert, is to pay a compliment. Those who read the book will appreciate this, and from the many apt references and quotations will feel that Dr. Balfour's gain to the profession is an obvious loss to "the cloth."

The papers deal with sanitation and preventive medicine in various parts of the tropics, both in the old and the new worlds, as well during the war as in peace time. Stress is rightly paid to the importance of insects as carriers of disease, and in the paper on the "Medical Entomology of Salonica" a useful account is given of the anatomy and distinguishing features of the various kinds of insects concerned. In giving an account of the "Preventive Inoculation against Typhoid and Cholera" the difficult problem of immunity is dealt with in a popular and lucid manner.

"The Palm from a Sanitary Standpoint" has been specially written for this volume and has not appeared in print before. The effect of palms on mentality, their domestic and economic uses, their employment as breeding places by mosquitos and other insects, are among the subjects dealt with and give interesting reading.

The book should prove of considerable value to anyone, medical or lay, proceeding to or living in the tropics, and even those whose life is spent at home will find much to interest them and help the spread of the gospel of hygiene at home as well as abroad. The book is well produced and is illustrated with many admirable photographs.

THE INVOLUNTARY NERVOUS SYSTEM.

In this little book on the sympathetic and associated systems, to which Professor PIERRE MARIE contributes an introduction, M. GUILLAUME,⁴ who is already known to British readers by his studies on the neurological injuries and diseases of war, has produced a short account of the involuntary nervous system, dealing with its anatomy, physiology, and pathology, as well as with its clinical aspects. The nomenclature of the subject is confused, and a general agreement about it is urgently needed. British readers, following Gaskell, would prefer the term "Involuntary Nervous System," dividing this into sympathetic proper and parasympathetic. A brief introduction is followed by chapters on the morphology, anatomy, and physiology; they are concise and well illustrated by simple and clear figures in the text. The anatomical and physiological connexions of the parasympathetic system and the cranial nerves are well described. The clinical pictures produced by injury or disease are given in considerable detail. Perhaps the author is a little too dogmatic in some

of his statements here, and he might have qualified his conclusions somewhat—for example, as to the effect of lesions of the cervical sympathetic. A useful chapter is one on the action of drugs upon the involuntary nervous system.

The vexed subjects of vagotonia and sympathicotonia receive full consideration in later chapters, where the views of Eppinger, Hess, and others are discussed. The author prefers the term *neurotonia* to *vagotonia*, believing that this picture is dependent on increased action of the sympathetic proper as well as of the parasympathetic system. Referred pains and the various visceromotor and sensory reflexes form the subject of another chapter.

The style is easy and the book is pleasant to read; the author may be congratulated on having compressed so much information into so small a space without sacrificing the clinical interests of the subject. We do not find any new material, but the book as a whole constitutes a good review of our present knowledge of this difficult subject.

SYPHILIS IN THE TROPICS.

THOSE who are accustomed to see eruptions on the skin of Europeans are often puzzled when confronted with similar conditions in dark-skinned races. The book on *Syphilis, with Special Reference to the Tropics*,⁵ by Mr. K. K. CHATTERJI, F.R.C.S.I., will help to lessen this difficulty in respect to the lesions of syphilis, as his material is largely drawn from the peoples of India. Chapter XI deals specifically with the tropical aspects of this disease; we wish it were longer. It is important, for example, to know that 96 per cent. of undiagnosed tropical ulcers give a positive Wassermann reaction.

The author has a high opinion of the therapeutic properties of margosa oil, obtained from the margosa or nim tree which abounds in all parts of India; from early times its healing powers have had a high reputation. The mode of preparation of margosic acid and its salts was described in the *Indian Journal of Medical Research*, April, 1918, p. 656. The drug is given by intravenous or intramuscular injection, and arsenic, mercury, and other salts are used. As further investigations are in progress it would be premature from the information in our possession to express any opinion as to the value of the drug.

The book is evidently the outcome of much care and labour, and a good deal of technical information has been incorporated in it. Some of the illustrations are lacking in clearness, and at times fail to convey a precise idea of the eruptions they represent, but no doubt this defect may be attributed to the difficulties of the present time, and will be corrected in future editions. There is an excellent bibliography of recent work, and the indexing has been done in an admirable manner. We believe the book will prove useful to those for whom it is intended—namely, to practitioners in the tropics.

TWO MEDICAL POETS.

DR. DAVID RORIE of Cults is well known as a poet of the vernacular to his Aberdeenshire friends, and doubtless many who served with him in the war, where he was A.D.M.S. of the 51st Highland Division, receiving the D.S.O., and being named Chevalier de la Légion d'Honneur, made the same discovery.

When the sharpest flint made the deepest dint,
An' the strongest worked his will,
He drew his tune frae the burnie's croon
An' the whistlin' win' o' the hill.

Like "the man o' the cave," Dr. David Rorie draws his inspiration from "hameowre" (homely) themes. The poems are the musings of a country doctor. His Doric has the sturdy lilt of Aberdeenshire, though here and there a note of Fife is heard. He who loves the Doric and a laugh should read *The Auld Doctor*.⁶ The themes are typical, and the humour sure and human. Two of the poems appeared in *The British Students' Song Book*, "The Lum Hat wantin' the Croon," and "The Pawky

³ *War Against Tropical Disease*. Being Seven Sanitary Sermons addressed to all interested in Tropical Hygiene and Administration. By Andrew Balfour, C.B., C.M.G., M.D., etc. Published for the Wellcome Bureau of Scientific Research by Messrs. Baillière, Tindall, and Cox. 1920. (Cr. 8vo, pp. 280; 24 gravures. 12s. 6d. net.)

⁴ *Le Sympathique et les Systèmes Associés*. By A. C. Guillaume. Preface by Professor Pierre Marie. Paris: Masson et Cie. 1920. (Cr. 8vo, pp. 150; 21 figures. Fr. 6.50 net.)

⁵ *Syphilis in General Practice; with Special Reference to the Tropics*. By K. K. Chatterji, F.R.C.S.I. With an introduction by W. D. Sutherland, C.I.E., M.D., I.M.S. Calcutta and London: Butterworth and Co. (Demy 8vo, pp. xx+382; 56 plates. Rs. 15 net.)

⁶ *The Auld Doctor, and Other Poems and Songs in Scots*. By David Rorie, M.D. London: Constable and Co., Ltd. 1920. (Demy 8vo, pp. 61. 3s. 6d. net.)

Duke." As an expression of the concrete, nothing can be better than—

The burn was big wi' spate,
An' there cam' tum'lin' doon
Tapsalteerie the half o' a gate.
Wi' an auld fish-hake an' a great muckle skate,
An' a lum hat wantin' the croon!

"The Pawky Duke," like the origin of Rorie's ballad of "Macfadden and Macfee," shows the pawky author with his tongue in his cheek:

An' if he met a Sassenach,
A-tour in Caledonia,
He gart him lilt in a cotton kilt
Till he took an acnte pneumonia!
Heh mon! The pawky duke!
An' a Sassenach wi' pneumonia!
He lat him feel that the Land o' the Leal
'S nae far frae Caledonia!

Every poem tells its story, from the complaining wife that

had some unco queer mishaps,
Wi' nervish wind and clean collapse.
An' naethin' does her guid but draps--
Gnid draps o' barley-bree, O!

to the obese Mistress Mucklewame, diagnosed by a "speeshalist" as suffering from "ang-bang-pang." The longest poem and the most amusing is "Tam and the Leeches," in which medical humour is given full scope and the druggist shop is depicted with the eye of a Hogarth. In its general plan "Tam and the Leeches" is reminiscent of "Tam o' Shanter."

Dr. C. J. WHITBY belongs to an altogether different school. For him life is full of seriousness and his mind and ear are sensitive to every modern movement. He has collected poems written at various dates, and for the most part published in earlier volumes or periodicals, into a book entitled *The Rising Tide*.⁷ It consists of three parts, the first comprising poems written during the war or the years immediately preceding it, the second containing miscellaneous poems of earlier date, and the third two episodes from an unfinished epic, "The Deeds of King Olaf." The poem which gives its name to the volume, like several others in the first part, is in irregular unrhymed verse. Dr. Whitby, in a foreword, says that it is "strange that the universally significant, the pre-eminently poetic topic of childbirth should so generally have been overlooked or neglected." Though the realism of the writing is strong it is free from offence, and the poem may be compared, not to Dr. Whitby's disadvantage, with Zola's famous prose description. Among the earlier poems we find some agreeably turned verses entitled "On Leaving Limpley Stoke." Among the recent poems in more regular measure we would give high place to "Salutation," addressed to the first Canadian Contingent. From it we may quote the concluding stanza:

Canada, Canada!
Transient are the losses and the pains
But the splendour of the deed remains.

Generations yet unborn shall tell
How the brave Canadians fought and fell.

Pride with grief contends in me; for one
Called me father. Sleep'st thou well, my son?

NOTES ON BOOKS.

THE fortieth volume of the *Transactions of the Edinburgh Obstetrical Society* embraces the proceedings of the society during the session 1919-20. The meetings were suspended during the war, and this is the first volume that has appeared since the session 1913-14. The contents include Sir Halliday Croom's valedictory presidential address, and papers by Dr. Lamond Laekie on artificial rotation of the head in persistent occipito-posterior positions; by Dr. Francis Browne on the histology of hydatidiform mole in its relation to prognosis; by Dr. Berry Hart on persistence of puerperal septicaemia since the end of pre-antiseptic times; by Dr. Robert Robertson on vaccine therapy in gynaecology and obstetrics; by Dr. J. W. Ballantyne and Dr. F. J. Browne on the colour scheme in pregnancy; by Professor Jardine and Dr. A. M. Kennedy on suppression of urine in pregnancy

⁷ *The Rising Tide, and Other Poems*. By Charles Whitby, B.A., M.D. Cantab. London: Ekin Mathews, 1920. (Demy 8vo pp. 112. Price 5s. net.)
⁸ 1920. Edinburgh: Oliver and Boyd.

and the puerperium; and by Dr. Eardley Holland on cranial stress in the foetus during labour. The volume is well printed and well illustrated.

India has contributed many useful articles to the materia medica, but in addition to those that have found their way into the *Pharmacopoeia*, there are many drugs sold in Indian bazaars and used by native *vaids*, *Kucrajs*, and *lithis*. Many are very sparingly employed by European doctors, stocked in Indian hospitals and dispensaries. Books have been written on indigenous Indian drugs by Webb, Katy, I. D. Dey, Moodeen Sherrif, and others, but it is doubtful whether they have succeeded in introducing these drugs into practice to any considerable extent. Lieut.-Colonel G. T. BIRDWOOD, of the Indian Medical Service, has written a book the purpose of which is to commend and facilitate their use, more particularly in district and mission dispensaries. The book sets forth (1) a list of bazaar medicines according to their action as alteratives, antihelmintics, etc.; (2) a description of these, indicating alphabetically their source, action and method of use; and (3) an alphabetical list of diseases in the treatment of which various bazaar drugs may be usefully employed. Over two hundred prescriptions are given suggesting the best methods of their administration. As a practical guide to the use of these medicaments this handy volume leaves little to be desired. The book is well printed and bound, interleaved for notes, and carefully indexed. It is to be hoped that it will not only help to commend indigenous medicines to the notice of Indian medical men, but will lead to research into their therapeutical value.

CALENDARS.

The *Catalogue of the National University of Ireland*¹¹ gives complete information about that university and its three constituent colleges—University College, Dublin; University College, Cork; University College, Galway—and includes extracts from the regulations for courses in the Faculty of Medicine.

The current *Calendar of University College, University of London*¹² forms a comprehensive guide book to the courses, examinations, scholarships, and so forth in the various faculties; it is prefaced by the historical outline written by the late Dr. Carey Foster.

A much smaller volume, but one that has a certain general interest in view of the forthcoming Annual Meeting at Newcastle, is the *Calendar of the University of Durham College of Medicine*.¹³ Founded in 1852 as the Newcastle-upon-Tyne School of Medicine and Surgery, this medical school became associated twenty years later with the University of Durham, and when, in 1870, this connexion was knit closer, it received its present name.

⁹ *Practical Bazaar Medicines*. By G. T. Birdwood, M.A., M.D. Cantab., Lieutenant Colonel I.M.S., Civil Surgeon, Bangalore, Calcutta and Simla. Thacker, Spink, and Co. 1920. (Fcap. 8vo pp. 125. Rs. 5.85.)
¹¹ Dublin: Printed for the National University of Ireland by the University Press, Ltd., 1920.
¹² London: Taylor and Francis, 1920.
¹³ Newcastle-upon-Tyne: Andrew Reid and Co. Ltd., 1920.

APPLIANCES AND PREPARATIONS.

A Device to Assist in the Drainage of the Peritoneum. SIR W. L. DE C. WHEELER, Vice-President, Royal College of Surgeons, Ireland, writes: The thimble illustrated is of great assistance in making a suprapubic opening for drainage in cases of septic peritonitis. The primary incision, when the case is one of perforation of the stomach, duodenum, or appendix, is usually at a distance from the pubic region. A pelvic drain in most cases is desirable. At the end of the operation, before the primary wound is closed, the finger guarded with the thimble is introduced into the abdomen and seeks the interval between the recti muscles just above the pubes. At this point the space between the muscles is well marked. With the thimble as a guide a stab wound is rapidly made, dividing all the tissues down to the peritoneum. The latter is pushed forward and is opened by a nick of a sharp-pointed knife between the bars carrying the round knob. A drainage tube (Keith's glass tube for reference is fitted to the top of the thimble and is pushed with great ease to the bottom of Douglas's pouch. The device saves time and overcomes the real difficulty of opening the peritoneum through a small incision. If the unguarded finger is used as a guide, the peritoneum stretches itself over the rubber glove and it is troublesome to separate one from the other. Surgeons must avoid cutting too boldly on an unguarded finger in the presence of septic peritonitis.

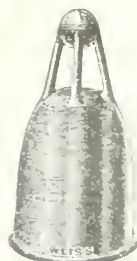

and is pushed with great ease to the bottom of Douglas's pouch. The device saves time and overcomes the real difficulty of opening the peritoneum through a small incision. If the unguarded finger is used as a guide, the peritoneum stretches itself over the rubber glove and it is troublesome to separate one from the other. Surgeons must avoid cutting too boldly on an unguarded finger in the presence of septic peritonitis.

THE VOLUNTARY PRINCIPLE IN LONDON.

A MEETING of the President and General Council of King Edward's Hospital Fund for London on January 26th received a report from the Executive Committee, which had been instructed to consider what principles of policy should be recommended to the Government for the preservation of the voluntary system of hospital management and control. The general recommendations of the Executive Committee were adopted as follows:

1. That the voluntary system of hospital management and control should be preserved as being the most efficient method of providing at the least cost the best medical and surgical treatment combined with advance in medical knowledge and practice;
2. That a substantial portion at least of the cost of the hospitals should be met by voluntary contributions;
3. That the present receipts from voluntary contributions are not adequate to meet the present cost of the London voluntary hospitals, to say nothing of the discharge of debts or the provision of necessary extensions;
4. That any method of increasing income should be such as not to stop voluntary contributions or do away with voluntary management;
5. That any policy or absence of policy which stopped voluntary contributions and did away with voluntary management would bring upon the public funds not only the cost of the hospitals but also additional cost of paid management and of general supervision by some central public department.

So far as could be ascertained, so soon after the conclusion of the year, the total expenditure of the London hospitals in 1920 was £2,841,000; this was £493,000 more than in 1919. The income from normal sources, including the ordinary grant from the King's Fund, was, in 1920, £2,447,000, leaving a deficit of £394,000; by an emergency grant of a quarter of a million made by the King's Fund on July 5th this deficit was reduced to £144,000. The aggregate debt of London hospitals, after deducting £200,000 given last December by the National Relief Fund towards the reduction of past deficiencies, was £544,000 (£138,000 less than in the previous year). Besides the amount required to meet current expenses and to discharge existing debts the hospitals in London also need a large sum to carry out and maintain various necessary improvements and extensions. Among these extensions is provision for approximately 1,500 additional beds.

It is considered that were the uncertainties as to the future of voluntary hospitals removed appeals for contributions would be more successful, but even so it would be necessary to supplement them by some other source of revenue. The possible methods, as to which experience is being accumulated, and of which exploration should be encouraged, include:

- (a) Various forms of contributions from patients in consideration of treatment received;
- (b) Various forms of regular contributions from prospective patients as a kind of quasi-insurance whereby a patient who has directly or indirectly been a regular subscriber should be regarded as having partly made a patient's payment in advance. Experiments in this direction might be encouraged.
- (c) Payment by Government or other public authorities in respect of the treatment of any classes of patients for whom those authorities have taken responsibility.

The opinion is expressed that, while direct grants from the State in consideration of their general work might endanger voluntary contributions and voluntary management, some form of assistance based on the amount received for the benefit of hospitals from voluntary sources, or some concession by way of abatement of income tax or death duties, proportioned to gifts, might prove practicable, and might serve to elicit a larger revenue than is now thus obtained.

It is pointed out that for many years past many hospitals have in fact been receiving payment from public authorities; besides naval and military patients treated during the war, payments have been received for tuberculous patients, venereal cases, war pensioners, maternity cases, school children, and others; the payment has usually been a grant-in-aid bearing some relation to the amount of work done, but not covering the whole cost. It is considered that the method has proved advantageous both to the voluntary hospitals and the public authorities. The Council of the Fund proposes to obtain the view of the individual hospitals in London and also of the British Hospitals Association on the question of payment in respect of the great volume of gratuitous work which the voluntary hospitals do for patients insured under the National Insurance Act.

While the need for increased income is great, it is held that attention should continue to be paid to the possibility of further economies in expenditure by strengthening the internal financial control of each hospital, by encouraging co-operation among the hospitals, and by securing that the best possible use is made of the various forms of voluntary accommodation and equipment. Upon this last point the report says:

It is clear that as the demand for hospital treatment grows, the voluntary hospital system must either expand so as to meet the whole of that demand itself; or submit to the establishment of other agencies to compete with it in the attempt to meet the whole of the need; or confine itself to meeting the whole of the increase in the particular kind of demand which it may be best fitted to meet. Different decisions between these three courses may be appropriate to different localities or to different kinds of hospital. But correct decisions there must be, if the voluntary hospital is to keep its proper place in the growing medical service of the country.

The voluntary hospitals of London have already prepared, with the sanction and encouragement of the King's Fund, plans for extensions to meet the most urgent need for further accommodation of the kind they are most fitted to supply. The report of the Distribution Committee in July last, at the time of the special distribution of surplus Red Cross funds in aid of schemes of extension and improvement, gave statistics of approximately 1,500 additional beds, which the Fund had already sanctioned, after paying due regard to the class of hospital and to the geographical distribution of the schemes in relation to the demand, and subject to the Hospital Committee being satisfied as to the prospect of funds for building and maintenance. This last condition assumes, of course, some solution of the general financial problem.

On the question whether the voluntary hospitals should attempt to cover the whole ground, and oppose all other methods of providing hospital accommodation, no recommendation is made, but the report contains the following observations:

We would remark that the present sphere of the voluntary hospital is the result of a process of specialization by which various sections of the increasing demand for hospital treatment have been taken over by other agencies, though the voluntary hospital still performs for those agencies, as for its ordinary patients, the services for which it is best fitted, including consultative work and the advancement of medical knowledge. We would mention the Poor Law infirmary and the public fever hospital as two instances. It is possible that the best use of the voluntary hospital accommodation and equipment, present and future, would be promoted by some further development of this principle of partial specialization, either, for example, between one voluntary hospital and another, or between a parent hospital and branches such as homes of recovery and convalescent homes, or even, as in the instances mentioned above, between the voluntary hospital and the non-voluntary hospital.

It is pointed out that any policy which may be adopted must provide not only for current expenditure and reduction of debt but for such extensions of the voluntary hospital system as is urgently needed.

A central body will, it is considered, be a necessary part of hospital organization. In the case of hospitals in London this, it is thought, could best be provided by a development of the present functions of King Edward's Hospital Fund, which might become the central administrative body for the metropolitan area. The administrative body of the extra-metropolitan hospitals should be separate, but for the formulation of general policy a joint body, composed of members of both, should be formed, and be independent of any Government department or other public authority. If the King's Fund became the central administrative body for the hospitals in London it would continue to investigate hospital finance and administration, to promote economies, to examine extension schemes, and to receive voluntary contributions, but it could likewise provide a channel for the receipt and distribution of some form of public assistance, should that be determined on, either in a permanent or in a temporary form. The Council of the Fund is, however, clear that individual hospitals should continue to be under the management of unpaid voluntary committees with fairly wide powers of discretion and initiative. The receipt of payment from public authorities has not hitherto led to any material change in this respect, and it is hoped that the advantages of the voluntary system would continue to be so generally recognized that public or other bodies making payments to the hospital would, if they desired representation, be satisfied that it should be so limited as to be acceptable to the hospitals and not inconsistent in practice with voluntary management.

THE RECORD CARD AS EVIDENCE.

BY A LEGAL CONTRIBUTOR.

MUCH has been written in the daily papers about "Record Cards." Some journals seem desirous of creating an impression that by reason of the publicity of the record card the secret of the consulting-room is to be no longer a secret; while others apparently assume that a record card becomes and remains a document which at all times and in all circumstances may be put in evidence either for or against the person with whom it deals.

In view of the fact that laymen do not always understand the law of evidence, it may be interesting to discuss the following question: "How far is an insurance medical record card evidence in a court of justice?"

It may be stated at once that it is not what the lawyers term a "privileged" document. This is for the simple reason that there is no such thing as medical professional privilege. A doctor is bound to state on oath in the witness box all he knows about his patient. This rule is well known and well recognized; but the writer has been unable to find the report of any case in which a doctor has been punished for its infraction.

Dr. Bateman,¹ indeed, recorded one case in which, on a summons by a married woman for arrears of maintenance, a medical practitioner was subpoenaed by the husband's solicitors. On being sworn, he was asked if he had not attended the woman professionally on a certain date, she being in labour. He declined to answer, claiming privilege. The Bench pointed out that such privilege did not obtain, and as he again refused they adjourned the case for a week in order to allow him to reconsider his position. He still refused when the court sat again, and the Bench allowed him to retire without inflicting any penalty. But it is conceived that some penalty might have been inflicted, or he might have been exposed to any action at the suit of the husband.

The record card, from the standpoint of the law of evidence, is in no better position than the evidence of the doctor himself. It is in no sense privileged. But is it admissible in evidence, and, if so, when and in what circumstances? This is a question which those responsible for the outcry about record cards in the daily papers do not pause to answer.

One thing is plain—the record card has not been made "evidence" by statute. In this respect it bears no resemblance to such a document as a death certificate, which is admissible (for many purposes) as evidence of the date and cause of death. The evidential value of an insurance medical record card must be considered according to the ordinary rules.

It is a general rule in courts of justice that the best evidence must be produced in order to establish a particular fact. Thus if the question is—Was Mr. A. suffering from influenza on January 1st, 1921? the best evidence is oral testimony of the doctor who then saw and prescribed for him. The doctor may make an entry of the fact in his diary or case-book or on the record card. But those entries are not evidence. So long as the doctor lives his testimony, given verbally in the witness box, must be adduced in order to establish the results of his diagnosis.

Suppose, therefore, a doctor were subpoenaed to produce his record card relative to Mr. A. The doctor might come to court and produce the card, but the card itself would not be evidence for or against Mr. A. It could only be used by the doctor as a memorandum made at the time to refresh his memory; but it could not be used otherwise, even if it came from official custody, unless the other party to the suit asked for and cross-examined the doctor upon it. It then becomes "evidence" of the facts recorded upon it. Its effect, as evidence, would be precisely the same as an entry in the doctor's diary.

The reason for this rule is very simple. The entry on the card was not made on oath. The lawyer treats it as mere hearsay. But, owing to the fickleness of human memory, the rule has long been recognized that any witness may refresh his memory from a contemporaneous record made by himself. The insurance medical record card might therefore be used in this way by the doctor who made the notes upon it.

The record card, however, will assume a new importance

after the death of the doctor. Entries made by him in his books or elsewhere have then an added value, and, when looked at from this point of view, that which may be written on the record card may be of great importance. It is a well known rule that entries made by a deceased person in the performance of his duty are admissible as evidence of the facts recorded; but they must have been made in the course of duty. Mere entries jotted down by a doctor in his diary are not so made. This may be illustrated by a case which was heard last year.² It was alleged that the respondent to a divorce petition was suffering from a certain disease which had been communicated to the petitioner. The doctor who had attended the respondent at the material time having died, his successor in practice was subpoenaed *duces tecum* to produce notes made by the deceased practitioner in connexion with his visits and attendances on his patients. The witness, having brought the notes to court, objected to producing them unless so ordered by the court. Sir Henry Duke refused to allow them to be read as evidence. He said that to render a note written by a deceased person admissible "it is essential that not only should it have been made in the due discharge of the business about which the person is employed, but the duty must be to do the very thing to which the entry relates and then to make a report or record of it. . . . I cannot see that any duty was cast upon this consulting physician to make these entries. He was practising alone and not in partnership, and he did not make the entries in pursuance of any duty to the persons consulting him, nor in pursuance of any statutory rule, or any binding rule of the profession. I am therefore not able to receive the entries." The same rule applies to oral statements made by a doctor.

In another recent case³ it appeared that a petitioner for divorce stated in the course of her evidence that she had consulted a medical man who made a statement to her as to the nature of an illness from which she was suffering. The doctor having died before the hearing of the petition it was contended that the statement, although it was hearsay, was admissible, as having been made in the ordinary course of duty. It was, however, rejected by Mr. Justice Bargaive Deane.

The record card, however, differs in a material respect from a mere entry in a diary. It is undoubtedly made in the discharge of a public duty, and, as such, it would be received in evidence. While not necessarily conclusive—for it might be proved, *aliunde*, to be erroneous—it would go a long way towards establishing the fact which it purported to record.

One other aspect of the matter ought to be mentioned. It would be competent for the Ministry of Health to claim privilege for record cards as being confidential documents the contents of which ought not, in the public interest, to be disclosed. That public departments will sometimes object to their records being produced on this ground was illustrated in a case which came before the Divorce Court in 1919.⁴ It was there suggested that the respondent, who was in the army, had contracted a certain disease, which he had communicated to the petitioner. Application was made to the War Office for the production of the medical history sheets relating to the respondent. Counsel for the Secretary of State for War objected to producing these documents, on the ground that they must be regarded as confidential documents, and that it was not in the public interest that they should be produced. The learned judge, who refused to order the production of these documents, said, when giving judgement, "The Secretary of State has declared as to the medical reports made while the respondent was on active service, that the exigencies of the public service precluded their production, and I am not in a position to quarrel with that decision. I am therefore excluded from a valuable source of information." It is interesting to notice that in the letter which was received by the petitioner's solicitors from the War Office refusing the information, it was pointed out that the doctors who attended the respondent might be subpoenaed to give such evidence as they could from personal recollection, "but the Department has at present no information as to who they were or where they are at present to be found." It should be mentioned that in this particular case a medical witness who had examined the respondent

² 35 *Times Law Reports*, 772.

³ D. v. D., 22 *Times Law Reports*, 52.

⁴ See *Times Law Reports*, vol. 35, p. 559.

after the period in question stated that in his opinion the respondent had never suffered from the disease in question; and the petition was in fact dismissed.

This case suggests a further inquiry. Assuming the War Office had consented to produce the medical history sheets, could they have been put in evidence unless the doctors responsible for the statements in them were called as witnesses? The answer to this may be found in the first part of this article. In the absence of the doctor who made the entries on the medical history sheets they would not have been available as evidence, unless the doctor were dead.

Whether the Ministry of Health will decline to produce record cards on the ground that they are public documents remains to be seen.

THE FUTURE OF POOR LAW INFIRMARIES.

RESUMED DISCUSSION AT THE HARVEIAN SOCIETY.

THE discussion at the Harveian Society on "The future of the Poor Law infirmaries," which was adjourned from December 16th, 1920,¹ was resumed on January 27th. Dr. G. DE BEC TURTLE presided over the meeting, which was held in Paddington Town Hall.

A communication was read at the outset from Dr. F. E. FREMANTLE, M.P., who was prevented by illness from attending. He wrote that there was a danger that the Ministry of Health, which was pledged to deal with the Poor Law in the near future, might, owing to pressure on Government time, decide to make use of the infirmaries to meet present needs, and so institute an additional system, with no fixed interests or limitations, which would make still more difficult the eventual establishment of medical provision on comprehensive and efficient lines. The aim should be to provide in every unit of administration a complete system for the treatment of the whole population. As much freedom as possible should be retained for doctor and patient, and for nurses, pharmacists, and others; as much as possible should be left to private enterprise, and it should be arranged for as much payment as possible to be made by the patient, directly or indirectly, but the State should be responsible for filling all gaps and co-ordinating all factors, institutions, and departments into an efficient and economical whole. Above all, it was necessary to insist that prevention, cure, and research must go hand in hand; the growing tendency, especially under State management, to separate these aspects of medical work was a serious danger.

Dr. A. G. STEWART, Medical Superintendent of Paddington Infirmary, entered upon a whole-hearted defence of Poor Law infirmaries against common misconceptions. It was often thought that the infirmaries treated only chronic cases, but in a recent year 50 per cent. of the patients admitted at Paddington made a stay of less than a month, and 75 per cent. a stay of less than two months. Nor did these institutions deal only with the aged, for 30 per cent. of the patients admitted were under 10 years of age. Again, Poor Law infirmaries did not deal exclusively with the sick of the workhouse; only 20 per cent. of the admissions in 1914 were workhouse patients; the great majority of the patients were hardworking people whose need for relief was only due to their sickness. Over 60 per cent. of patients in his infirmary paid towards their maintenance. The prejudice against Poor Law infirmaries had been exaggerated; he had been told by several general practitioners in the district that patients preferred the infirmary to the hospital. While admitting that infirmaries were not equipped or staffed to meet the new demands upon them, he resented the suggestion that they provided little more than food and shelter. For years such work as bonaplatting and grafting had been carried out at the infirmary, and hundreds of acute abdominal operations had been done annually. The nurses were as well trained, at any rate as regards private nursing, as in a general hospital. In defence of the guardians, he said that many boards took a surprisingly broad point of view, and devoted a good deal more time to their duties than the boards of governors of a general hospital. One complaint in which there was substance was as to the lack of classification of cases. But infirmaries were compelled to take in all medically deserving cases, however full they might be; they were not at liberty, like the voluntary hospitals, to set aside wards for certain classes of cases and fill up their vacancies

from waiting lists. Dr. Stewart believed that both the voluntary hospital and the infirmary had a distinct future. The first would approach matters rather from the scientific, research, teaching, and specialist point of view; the second rather from the economic and general practitioner point of view; but if there was some central authority to co-ordinate the efforts of both, great improvements would be effected and money saved. As for the staffing of the infirmary, while he had always welcomed the specialist, he was bound to say that a very large part of the work could be done equally well by the general practitioner, and he did not see why there should not be part-time general practitioners on infirmary staffs, provided—but only provided—that they demanded sufficient remuneration to justify them in giving the necessary time to the work. Infirmaries could also do a useful work in training residents to become general practitioners; there was scope also for research work and for students. In the infirmary the student would see cases likely to be as useful to him as the rarer cases to which he devoted so large a share of his attention.

Dr. REGINALD DUDFIELD, Medical Officer of Health for Paddington, said that the care of the sick must be regarded as a national duty. Since the great stocktaking of national health incidental to recruiting, emphasis had been laid upon the need for tracing the beginnings of disease. But it was rare for the failing man, as distinct from the sick man, to seek medical advice. He was withheld, not only by the prospect of doctors' fees, but also by the possibility of orders to slow down his business activities. The State must step in and relieve the failing man to some extent of his burden. The speaker was unable to appreciate the distinction between State or municipal assistance and Poor Law relief; it was merely the difference between taking money from the right-hand pocket or the left. Why should not the State or municipality be looked upon as a national charity organization society? To meet certain objections, the infirmaries should be transferred from the Poor Law to the municipal authorities; he was not in favour of the setting up of *ad hoc* authorities, which were too often wasteful in personnel and administration. The existing authorities, county or municipal, were fully competent. The infirmaries in London should be transferred to the London County Council, as recommended in the Maclean Report. With regard to staffing, there could be no doubt as to the necessity of a resident medical staff. The whole of the visiting staff need not be consultants; he would like to see the local practitioners as visiting physicians and surgeons; rosters of willing practitioners might be formed. Every ratepayer should have the right of admission to the new hospitals if such admission was certified as necessary by the practitioner in charge of the case. This right would not mean free treatment in every case, but the principle of assessment now enforced by the London County Council for the treatment of the uninsured tuberculous might be applied. While no one would be compelled to enter the institution, such entrance in certified cases should be made a condition precedent to the granting of State aid for dependants.

Dr. J. B. COOK, from his sixteen years' experience of the inside working of several Poor Law infirmaries, regretted that certain unfounded and inaccurate statements should have been made (apparently in the previous discussion). The treatment of the sick poor as now enforced by the Ministry of Health was not in the parlous condition in which it had been represented. The infirmaries took in chronic cases, of course, but they also took in numbers of cases for which the voluntary hospitals had inadequate accommodation. If the infirmaries were "the rubbish-heaps of practice" he was proud to have such rubbish on his heap. Specialists were attached to many infirmaries, both in London and the provinces. The equipment in the institutions with which he was acquainted left little to be desired. The training of nurses in the modern infirmary was quite equal to that given in the average hospital. It was not the future of the infirmaries, but that of the voluntary hospitals, which was uncertain. In his view the infirmaries should become State hospitals for their respective areas. There was room both for the infirmaries and for the voluntary hospitals with their medical schools, but if the voluntary hospitals had to curtail their activities through lack of funds the State must come to the rescue there also, either by enlarging the State hospitals, or subsidizing the voluntary ones, or doing both. The infirmaries should be more adequately staffed with resident medical officers; and specialists should be available at each infirmary to act in consultation with the resident staff as required, and also to undertake certain specialist duties such as x-ray and laboratory work and electrical treatment. Finally, paying patients should be more widely encouraged.

¹ BRITISH MEDICAL JOURNAL, December 25th, 1920.

These suggestions would not entail any vast outlay, nor would they materially upset the existing institutions.

Dr. R. H. COLE said that it would be very useful to have special clinics at the infirmaries with a view to getting at the beginnings of mental disease, but such work meant enlarged staffs and more expenditure. The part which infirmaries might play in the future from this point of view was very important and should not be lost sight of.

Mr. ZACHARY COPE spoke in praise of Poor Law infirmaries. In one such institution 800 major operations were done during a recent year. There were, however, certain infirmaries in which the work was not up to standard, and which bore out the criticisms Dr. Wilson had advanced at the last meeting. He thought there was something to be said for the policy of separating the executive from the medical and surgical side. He believed also that the Poor Law infirmaries in London might help to solve the problem of post-graduate teaching, for they would bring the opportunity of clinical observation almost up to the practitioners' doors.

Dr. A. BLACKHALL-MORISON brought to the discussion an interesting communication which, however, went beyond the limits of the subject before the meeting, and entered into the question of a State medical service and the insurance controversy; in consequence of the time limit he was not permitted by the President to complete his argument. He claimed that the disadvantages of the previous situation in medicine—that is, the situation previous to recent health legislation—had been grossly exaggerated for obvious purposes. At the time when the "incipient nationalization of medicine" was imposed upon the profession, the profession was by no means oblivious to its responsibilities. It had not neglected education or investigation. To-day, however benevolent the intention of the legislature towards the community in general, its attitude towards the medical profession was one of less pronounced consideration, and in some quarters to speak at all of the interests of the profession was regarded as iniquitous. The speaker strongly protested against the charge that the profession had consulted unduly its own interests, and he claimed that an orderly freedom was the best medium in which it could grow and exercise its beneficent functions. As for the Poor Law infirmaries, these required not only more but possibly better officering, but to admit this was not to say that these institutions should be alienated from the purpose for which they had existed—namely, the care of the impoverished or necessitous poor. Persons not in that category could find all the medical attention necessary in their own domicile, and it was only these who had drawn their conclusions from institutional as distinct from domiciliary experience who could think otherwise. Both the voluntary hospital and the Poor Law infirmary would find abundant occupation when limited to their proper purpose as hitherto, and the former would obtain the support which it now lacked and would lack still more if the present subversive politics even temporarily succeeded. The speaker suggested, finally, the setting up of a central medical council, which would be a reformed General Medical Council, with greatly increased powers. This body would be responsible for the investigation, prevention, and treatment of disease. Such a council would better arrange the distribution of medical activity, charitable and other, than any lay body, however advised, which had not the full consent and sympathy of a united medical profession.

Dr. H. W. BRUCE said that as a general principle a good medical staff made a good hospital; hence the question of the medical staff of the future State hospital was important. The basis of that staff would always be the general practitioner, and therefore the desire to bring in the general practitioner was to be commended. It seemed very sound, if not essential, that there should be some close connexion between the doctors who sent the cases into hospital and those who treated them. But in these State hospitals the old accusation that medical men always sent up the expense must not be made, and the cheapest way, combined with efficiency, of providing medical attention in hospital for patients was by means of whole-time general practitioners. A practitioner who was engaged partly outside and partly inside the hospital found both parts of his duty calling for him in the mornings. The speaker also referred to the function of the medical superintendent, who, he thought, should not be so overweighted with duties as at present. It was desirable that one medical man possessing the necessary authority should be simply in charge of the administrative side of a hospital, and control and co-ordinate its arrangements.

Dr. NATHAN RAW, M.P., opened with a reference to the Minister of Health, whose courage, he said, in introducing his Miscellaneous Provisions Bill was to be admired. The

speaker did not doubt that the bill would be reintroduced. The point they had to discuss that evening was not the merits of the Poor Law or the voluntary hospitals, but the best way of co-ordinating the values of all the services. The number of beds provided by the voluntary hospitals was totally inadequate to the needs of the community; hence the proposal to transfer the Poor Law infirmaries into the general municipal health service. This was not a State service, and he for one hoped they would never see a State medical service in this country, but there must be a service available for the community at large, and the question was how to provide such a service to the best advantage. He remembered that in 1897 an application was made from the Sefton Poor Law Infirmary, one of the biggest in the country, of which for a long time he had charge, for the provision of an operating theatre, and the matter from the political point of view was regarded as of such importance that the Local Government Board was called together (for the first time in many years if not in its history) to discuss the principle involved—namely, whether the Poor Law authorities ought to confine their attention to relieving the destitute as in the past, or should progress with the times and provide for the poor the latest and best treatment in the way of operating theatres, laboratories, and specialities. It was then decided that the best methods of treatment should be adopted in the infirmaries, with the consequence that a great many infirmaries were now just as well equipped as the general hospital. Another factor—the disappearance of the pauper class—had by now come into operation; there was not the same need for Poor Law infirmaries as there had been twenty years ago. The working classes of this country were being properly remunerated. He had heard many members in the House of Commons voice the sentiments of their trade-unionist constituents to the effect that neither should charity be accepted from the voluntary hospitals on the one hand nor relief from the Poor Law on the other; hence the great difficulty which the Government had to face. It was not a political question, but one of expediency. In his judgement, the Poor Law infirmaries which were really no longer required for the destitute poor ought to be taken over by the health authority of the district in which they were situated and used as general hospitals so as to be available for all. This question had come to a head on account of the difficulty of securing support for the voluntary hospitals. Those hospitals were established simply as charitable organizations, and the general public no longer desired charity. On the other hand, he believed that legally no one could be received in a Poor Law institution unless sent by the relieving officer or as a case of urgency. If it was not legal to take non-paupers into Poor Law infirmaries, then the position should be legalized by transferring the infirmaries to the municipal authorities by consent. A certain amount of opposition would be raised to that policy, but in his opinion it was the only one possible.

Dr. J. C. MUIR said that the more one listened to discussions on this subject the more evident it became that the time was coming when it would be the normal proceeding for any person who was ill to go into hospital. If this were so the quality of such work which could be undertaken by voluntary hospitals must grow proportionately less, so that it seemed to be inevitable, whatever the hesitation and regret, that hospitals should be supported increasingly out of public funds. No doubt the public hospitals (the present voluntary hospitals) would continue to be the centres of teaching and research and advance, whereas the new hospitals (the remodelled infirmaries) would be the places in which the result of such advances was carried out in practice to the widest extent by the ordinary practitioner, who would have specialist opinion available.

Dr. C. L. TRAYLEN said that he was able to follow his patients into hospital at Willesden, and he thought it would be a great encouragement to the general practitioner if he was permitted to follow his cases into what were at present known as the Poor Law infirmaries.

Dr. WITHERS GREEN suggested that the old Poor Law service and panel service might be grouped together, and that here the infirmaries would play an important part, while paying patients should be received at the voluntary hospitals. There must be no suggestion of inferiority of medical service in one set of institutions as compared with the other. The appointments must be open to competition.

Dr. HUBERT C. PHILLIPS thought that the difficulty of appointing general practitioners to hospital posts was exaggerated. His own experience during the war as Deputy Commissioner for Bedford, as well as his experience in other capacities, suggested the contrary.

The PRESIDENT, in closing the discussion, said that

there was no doubt at all that changes were imminent. He hoped that there would be as large an amount of local autonomy as possible. The details of any particular scheme should be left to the district in which the scheme was to be worked. He was certain that, if the linking-up of institutions could be localized it would be the best plan of all so far as London was concerned. Each voluntary hospital might be linked on to two infirmaries. As for the selection of general practitioners, what better way presented itself than to make a combined medical committee of hospital and infirmary the selecting body?

TUBERCULOSIS IN 1919.

THE returns for 1919, given in the report of the Registrar-General for 1919, show a marked diminution in the number of deaths from tuberculous affections; they numbered in the aggregate 46,312 (24,550 males and 21,762 females), or 11,761 fewer than in the previous year. The crude mortality amounted to 1.258 per million—considerably below that of any previous year, the lowest hitherto having been 1,352 in 1913. The corresponding standardized rates are 1.261 in 1919 and 1,339 in 1913.

Discussion of the statistics is again embarrassed by the fact that it is considered essential to exclude the male sex, because the violent and incompletely traced fluctuations in the male population due to the war make it impossible

to determine a series of reliable and comparable mortality rates for males. In the analysis of the figures, therefore, deaths of females are alone dealt with, as in previous reports since the outbreak of war. Pre-war experience seems to justify the assumption that the trend of mortality over a few years can be established by the experience of females alone, but, as Dr. Stevenson points out, this is perhaps open to question.

It is remarkable that a fall in the mortality from tuberculosis occurred in 1919, notwithstanding the effects of the influenza epidemic which continued into the early part of the year. Dr. Stevenson gives reason for concluding that the recent trend of tuberculosis mortality can only be profitably studied by disentangling it from the mortality caused among the tuberculous population by influenza. When this is done, he considers that the figures show that the tuberculosis mortality reached a maximum in 1917, and that a decline set in during the last year of the war, and developed to a remarkable extent during the first year of peace. He considers it necessary to lay stress on these points, as in the absence of their consideration the recently experienced tuberculosis mortality has been regarded as disappointing. In seeking to arrive at a conception of the course of tubercle mortality during 1918-19 an attempt has to be made to estimate what this would probably have been in the absence of the violent disturbance caused by influenza. Accordingly, the mortality of each quarter of the year is considered separately: only the second quarter was unaffected by influenza, and the other three quarters were affected in varying degrees. A diagram illustrating the mortality of females from tuberculosis in each quarter from 1911 to 1919 inclusive is here reproduced. It will be seen that after remaining at a minimum in the years 1912-14, the quarterly rates gradually increased during the three following years, but began to fall again during the first two quarters of 1918, after which the great epidemic of influenza temporarily arrested the fall, raising the rates for the next three quarters to a high level. The normal seasonal rise and fall of tuberculosis mortality shows a minimum in the third quarter and a maximum in the first or second. The second quarter was unaffected by the great epidemic, and is taken as most nearly representing the probable behaviour of the yearly

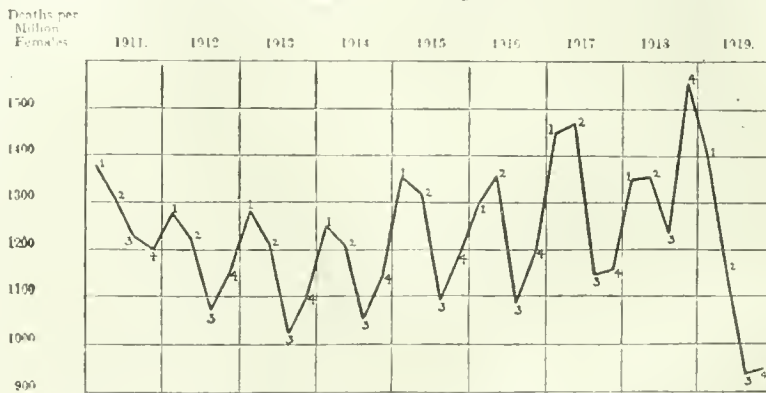

Mortality of females from tuberculosis in each quarter (1, 2, 3, 4) of the years 1911-19.

mortality if the epidemic had not occurred. The curve of the mortality of the second quarter, after maintaining a minimum for the three years 1912-14, gradually rose during the next three to a maximum in 1917 and then fell uninteruptedly to 1919, when the lowest point was reached. There was a reduction below the nine years' average from 10 to 20 per cent. in the last three quarters' mortality, but Dr. Stevenson points out that caution must be exercised in interpreting this.

"If," he says, "influenza increased the death rate of the preceding three quarters by killing off tuberculosis patients who would otherwise have died a little later, the great fall which has occurred since the epidemic came to an end may be in part attributable to this earlier removal of persons who would otherwise have died in the quarters of low mortality."

He does not, however, consider that this is a serious source of error. There is no evidence that mortality from the non-pulmonary forms of the disease was increased by the epidemic; these non-pulmonary rates were very low in 1919, and this is thought to point to a real decline in the destructiveness of tuberculosis. The statistics do not suggest an explanation of the reason why the increase of mortality which earlier experience seemed to connect with the war should have given place to a decrease in the earlier part of 1918, while war conditions were still at their maximum. The decline in 1918 would have been even greater but for the increase of the mortality returns

from lunatic asylums; the number of the deaths in asylums fell from 5,605 in 1918 to 3,326 in 1919. The institutional mortality, however, remains very high, for the asylum deaths in 1912-14 numbered only about 1,800 a year; it is hoped that the restoration of normal conditions in asylums will lead to a further reduction of the general mortality.

The continued fall in tuberculosis mortality in both sexes at ages 0 to 5, which Dr. Stevenson considers is perhaps the most prominent feature in the recent movement of the tuberculosis mortality, was greatly accelerated in 1918. The rate used to be the highest at any age; it is now exceeded at several other ages. The age of highest female mortality was (1851 to 1890, 25 to 35; in 1891 to 1910 it was the age period 35 to 45; since 1916 the age group with the highest rate has been 20 to 25, except in 1917, when that for 15 to 20 was higher. It has been thought possible that the heavy increase of the mortality among women at ages 15 to 25 which occurred during the war was due to increased employment, but Dr. Stevenson points out that even before the war the fall in mortality was shared only to a trifling degree by females of these ages.

SINCE the Ministry of Pensions entered into possession of Ewell Colony, which has been leased to the Ministry by the London County Council for two years from November 1st for the treatment of pensioned patients suffering from shell shock, neurasthenia, and kindred conditions, 245 patients have been admitted and 28 have been discharged. The total accommodation provided is 400 beds.

THE London County Council is asking the Minister of Health to receive a deputation for the purpose of representing the urgent need for the provision of accommodation for transmigrants whilst in the Port of London, and for preventing transmigrants suffering from infectious diseases from becoming a source of infection to the population. During the past few months there has been serious overcrowding in premises utilized for the accommodation of transmigrants, and cases of favus and trachoma have been found amongst the transmigrants in London.

British Medical Journal.

SATURDAY, FEBRUARY 5TH, 1921.

THE PREVENTION OF LAMENESS AND DEFORMITY.

THE Cameron Lecture, published in this issue, is, we venture to think, worthy of the careful attention of the authorities of all medical schools. Speaking at Edinburgh, Sir Robert Jones made special reference to conditions there; but the principle involved is the same everywhere, and its importance has already been recognized by some schools, including Liverpool, and at least two in London—St. Thomas's and King's College. Briefly stated, the lecture is a plea for giving to medical students during the course of their ordinary curriculum some general idea of the principles upon which rests the department of medicine that, for want of a better name, must be called orthopaedics.

Very great progress has been achieved during the last twenty or thirty years through the application of the primary principles of physiology and pathology to the problems presented by congenital defects and the consequences of accident or disease affecting the limbs. Coupled with this development on the philosophical side have been simplifications and improvements on the practical side; aseptic surgery rendered possible many kinds of operations which the earlier orthopaedic surgeons did not dare to attempt, and almost at the same time Thomas of Liverpool devised methods and appliances which in their directness and simplicity bore the stamp of genius. The study of his methods afforded a starting-point for a few ardent spirits in this country and America, who have advanced the department of orthopaedics to its present position. Not only are the principles which should guide the treatment of congenital deformities and of fractures better understood and the methods of treatment greatly improved, but ideas on the treatment of infantile paralysis, and to some considerable extent of tuberculosis of bones and joints also, have been profoundly affected. We now see more plainly that early treatment can do much, and have learnt what the nature of that treatment should be. It is perhaps true that there has been, on the part both of the profession and of the public, a disposition too readily to accept deformities as inevitable evils, and undoubtedly the task of those few surgeons who have given special attention to their remedy has been made harder because treatment has not been attempted at a sufficiently early date. The war produced an enormous number of injuries of the limbs, and observation made plain the ill effects of delayed or imperfect treatment, and demonstrated the remarkable success to be obtained when well-devised methods were early instituted. It is, for instance, astonishing to be told that in the three hundred cases of fracture of the femur in the special military hospital at Edmonton at one time the average shortening was less than half an inch, and that at the Alder Hey military hospital results equally good were obtained from the use of Thomas's splint in its original simplicity.

We have a fairly well defined set of conditions which, though due to different causes, have two

things in common: first, that their treatment calls for the application of the same or similar principles and appliances, and secondly, that they are of great economic importance. Further, it is agreed that treatment on the correct lines ought in all cases of this class to be instituted at the very earliest date. Even if the practitioner is not himself prepared to undertake the initial manipulations, where such are necessary, it is important that his training as a medical student should have included sufficient instruction in the principles and methods of orthopaedics to enable him to judge what can be done, and when it can best be done, and to conduct the after-treatment, for which, indeed, the operations and manipulations of the specialist are only preparatory.

We entertain no doubt that the case for a special orthopaedic teaching department in every medical school has been fully made out, and we believe that anyone who looks into the facts must arrive at the same conclusion. The plan proposed seems to be in line with recent developments in the organization of medical education, which have been designed to render it possible for the student, within the time available, to receive a grounding in all the many subjects his acquaintance with which must be sufficient at least to enable him in after-life to judge their relative importance. We do not mean that cases of this nature should be withdrawn from the scope of the general surgeon; the contention is that there should be a special teaching department in which every student should receive instruction in principles he ought thoroughly to understand. Nor will it lay another burden upon the student; he is not asked to give more time, but is offered greater facilities for acquiring knowledge in a department of practice with which it is essential he should be acquainted when he goes into general practice. If he will then have relatively few cases of fracture to treat, he will certainly be consulted about many congenital deformities, and will have to treat the results of acute anterior poliomyelitis, tuberculosis of bones and joints, and often rickets. It may be that in some medical schools it will at first be difficult to make the readjustments necessary for the establishment of an orthopaedic department under a special surgeon, but that these difficulties can be overcome is proved by the plan described by Sir Robert Jones as already in force at the Liverpool Royal Infirmary and St. Thomas's Hospital; King's College Hospital also has established an orthopaedic teaching department. We cannot suppose that Edinburgh, the largest medical school in the British Empire, with traditions envied by all, to quote Sir Robert Jones's estimate, will lag behind. The moment is favourable for action, when the lessons of the war are still fresh in the minds of the profession and of the public.

THE INDUSTRIAL FATIGUE RESEARCH BOARD.

In the *Scotsman* of January 24th the categorical announcement is made that "the Treasury have intimated that after the end of March they will not be able to continue any allowance to the work of the Industrial Fatigue Research Board, which it is suggested should be dissolved, and the work undertaken by other authorities or borne by the industries themselves." Our contemporary optimistically holds that this decision "will incur the opposition of practically all progressive employers and labour leaders," and directs attention to the importance of the work already carried out by the Board's staff, instancing

the researches of Dr. H. M. Vernon into the methods of the iron and steel industry, of which we gave some account a fortnight ago (January 22nd, p. 131). The history of this Board is so instructive that we may be permitted to recall certain facts. Three years ago, in December, 1917, the Department of Scientific and Industrial Research was invited by the Home Secretary to appoint a committee to investigate the subject of industrial fatigue on comprehensive and systematic lines. The suggestion was welcomed by those to whom it was addressed. It was apparently felt that a more imposing body than a mere temporary committee was needed, so the Department of Scientific and Industrial Research and the Medical Research Committee (as it then was) appointed a Research Board to organize and direct researches falling within the following terms of reference: "To consider and investigate the relations of the hours of labour and of other conditions of employment, including methods of work, to the production of fatigue, having regard both to industrial efficiency and to the preservation of health among the workers." The personnel of the Board now includes the President of the Royal Society, who has been chairman since the Board's inception, two other distinguished Fellows of the Royal Society, Sir Joseph Petavel, Director of the National Physical Laboratory, and Dr. C. S. Myers; also two leading authorities on industrial medicine, Dr. T. M. Legge and Professor E. L. Collis, and such representative employers of labour as Mr. W. L. Hichens, Chairman of Cammell, Laird and Co., and Dr. Kenneth Lee, of Messrs. Tootal, Broadhurst, Lee and Co.

The task entrusted to the Board under the terms of reference was immense. Before the pioneer researches of the Health of Munition Workers Committee (under the leadership of the present Chief Medical Officer of the Ministry of Health) practically no systematic scientific investigations of the human factor of industry had been carried out. The Health of Munition Workers Committee reached various important conclusions which, like most good scientific work, pointed the way to other urgently needed researches. But the supply of trained investigators was small; it consisted, indeed, only of those who had been employed by the Health of Munition Workers Committee. The Board had therefore, in the first place, to assemble and train a staff, and to deal with such problems as its immediate resources enabled it to investigate. The first annual report, issued only a few months ago, recorded a very promising start, and thirteen reports have already been published or are at press. These include the report by Dr. H. M. Vernon above mentioned, which contains, *inter alia*, an extensive analysis of the sickness and mortality experienced by 24,000 iron and steel workers which is of great interest to the student of industrial morbidity. Another investigator of the Board, Mr. P. M. Elton, has made a report upon production in silk weaving which brings out the detrimental effect upon output of working by artificial light; while Dr. Vernon, in another memorandum, has shown that although increase in hourly output follows at once upon reduction of hours the converse is not true, but a fresh state of equilibrium takes time to establish.

To the trained man of science, familiar with the difficulties of investigating a new field, the slow evolution of an appropriate technique, and, above all, the pains needed to organize a staff, the achievements of the Board in its first year will seem creditable. Such a person might suppose that the eminent men of science who have devoted time and thought to what,

in 1917, was regarded as a matter of vital national importance, would be given an opportunity to build upon the foundations they had constructed. But, to judge from the paragraph in the *Scotsman*, any such supposition would be wide of the mark. The President of the Royal Society and his colleagues may be gratified as taxpayers at this new success of the economy campaign, even if, as men of science, they may feel some little disappointment at the outcome of their labours. After all, 1917 was a long time ago, and the financial condition of the country was no doubt eminently prosperous then; it could hardly have been foreseen that in 1921 there would be any real need for economy, while the officials of the Treasury no doubt expected that the Board's terms of reference would have been discharged within two years at most; this is the view that any administrator devoid of scientific training would naturally take.

We have at least the satisfactory assurance that knowledge will continue to be acquired, since, as we understand, similar research organizations have been created by the Governments of the United States and France. These organizations will have derived advantage from the spade-work of the English Board, and their results will, with due regard for economy, be abstracted in the English journals.

A cynic has remarked that the wise father will always steadily prophesy evil of his son, since, whatever happens, either his paternal feelings or his intellectual vanity will be flattered. We have often expressed the fear in these columns that the war-time enthusiasm for science in general and for medical science in particular, having no root in an educated public opinion, would wither away, so that we cannot pretend to be surprised by the fate which has overtaken the Fatigue Research Board: it is precisely what we should have anticipated. But there is one point which specially concerns the medical profession. According to its last report, the Medical Research Council is in some sense responsible for the Fatigue Research Board, and, presumably, approved its plans. Are we to infer that the action of the Treasury, as expounded by the *Scotsman*, is to be interpreted as a hint to the Medical Research Council, like that of Flaminius to the Achaean League? If so, what are the limits of the shell beneath which the head of the tortoise is safe? The time may not be far distant when other objects of research yet more intimately connected with the progress of general and preventive medicine will be consigned by the Treasury to the scrap-heap.

We have not told this story for the mere journalistic pleasure of criticizing a Treasury decision. If the facts are as stated by our contemporary, and if the decision to dissolve the Board and dismiss its staff has been reached suddenly and only communicated to those concerned within a few weeks of its contemplated coming into effect, it is undeniable that so honoured a member of our profession as the President of the Royal Society has been treated with discourtesy and avoidable hardship has been inflicted upon younger investigators. But, in these times, discourtesies and even hardships are no great matters. What is of vital importance for us all to realize is that the ideals of science, instead of counting for more, count for much less than six years ago. Viewed from this aspect, no more instructive incident could have happened. Abstractly considered, scientific research could hardly be presented to the British public in a more inviting shape than that provided by the terms of reference and the personnel of this Fatigue Research Board. The terms of reference made an appeal both to the spirit of humanity and to the

yearning for industrial efficiency—it were, perhaps, too harsh to say to the cupidity—of the average Briton. A combination of the holder of the greatest honour in British science with the foremost representatives of organized industry would seem unshakable. That a scheme launched under such hopeful auspices should be shipwrecked almost at the beginning of the voyage is indeed a portent.

“We are witnessing,” said Dr. Inge in last year’s Galtou Lecture, “the decline and fall of the social order which began with the industrial revolution 160 years ago. The cancer of industrialism has begun to mortify, and the end is in sight.” That a national application of scientific method to the study of the human side of industrial organization is one of the first things to be sacrificed when expenditure must be curtailed, is a proof that the Dean of St. Paul’s has accurately diagnosed the case.

THE LONDON UNIVERSITY LABORATORY.

A FEW weeks ago a brief account was given of the circumstances which threaten the early closure of the Physiological Laboratory of the University of London, and regret was expressed that the Senate should have rather tamely acquiesced in the extinction of the one laboratory under its direct control. Briefly the story is this: The Laboratory was established in 1902; the University granted the use of the top floor (then unused) of that part of the building of the Imperial Institute, South Kensington, which it occupies; a sum of £4,000 was provided by private benefactors for equipment. Professor A. D. Waller has been director, unpaid, from the first. The cost of upkeep is about £1,300 a year; of this the London County Council has provided £500 and the University the remainder. There is no question of the efficiency of the Laboratory and of the value of the work done there. It has had a great influence on the progress of physiology, for it is a research laboratory with an organization for higher teaching—for teaching the teacher, in fact. In 1906 Convocation took it as a model upon which other university research laboratories and courses of advanced lectures might be formed. In 1908 the Senate received and endorsed identical reports from the Academic Council and the Council for External Students, to the effect that it was highly desirable to continue the work of the Physiological Laboratory as forming a valuable part of the work of the University. The present unfortunate state of things has been brought about, or at least precipitated, by the London County Council’s announcement that it intends to stop its grant of £500 a year. Thereupon the Senate, on December 15th, resolved that, failing the assurance of adequate support from the County Council or other sources before the end of March, the Laboratory must be closed not later than the end of next July. It seems a poor little economy for either of these public bodies to attempt—poor in spirit and little in amount. The Senate is said to be influenced also by a desire to obtain more space for its clerical staff, but at present the key of the situation is in the hands of the County Council, and we trust that it will listen to the advice tendered to it. At its first meeting after the Senate’s decision was known the Physiological Society unanimously adopted a resolution expressing its opinion that the closure of the Laboratory “would be a grave injury to the advancement of science and knowledge and to the teaching of physiology in London, and would therefore be contrary to the public interest.” This view is generally held in the medical profession and by all men of science. It is that of the teaching profession, and, indeed, it must be shared by the great majority of educated persons in London and throughout the country.

CONGRESS OF RADIOLOGY AND PHYSIOTHERAPY.
The first Congress of Radiology and Physiotherapy, organized by the Electro-Therapeutic Section of the Royal Society of Medicine and the British Association of Radiology and Physiotherapy, will be held in London on April 14th, 15th, and 16th, 1921, under the presidency of Sir Humphry Rolleston, K.C.B. The opening ceremony will take place at the Royal Society of Medicine on Thursday, April 14th, at 10 a.m. The work of the Congress will be divided into three sections—Radiology, Electrology, and Physiotherapy—and at each session opening papers will be read by representatives of France, Belgium, and England. All communications may be made in French or English. In addition to the set discussions and demonstrations, visits will be paid to the radiographic and electrical departments of selected hospitals in London. The Sections of Electrology and Physiotherapy at a joint meeting will discuss the re-education of muscles, which has formed the subject of recent correspondence in our columns. In connexion with the Congress there will be an exhibition of electrical and x-ray apparatus, and the social functions will include a Congress dinner and a visit to the universities of Oxford and Cambridge. On Saturday afternoon, April 16th, there will be a demonstration of physical training, organized by the Ling Association, at the Albert Hall. The subscription for English members is 2 guineas; that for French and Belgian members 40 francs. The Secretary-General is Dr. G. Harrison Orton, and the honorary treasurer Dr. J. Metcalfe, to whom subscriptions should be addressed at the Royal Society of Medicine, 1, Wimpole Street, W.1.

THE PANDEMIC OF INFLUENZA.

THE report on the pandemic of influenza (1918–19), which has been issued by the Ministry of Health, is, both from the scientific and from the practical or clinical point of view, a contribution of no little value to medical literature.¹ It consists of three parts: the first, dealing with the epidemic in Great Britain and Ireland, has been prepared by Dr. Major Greenwood and Dr. Thomas Carnwath, in collaboration with Dr. Herbert French and Sir Frederick Andrewes. A history of influenza in England from 1658 to 1911 is followed by a discussion of the statistics of 1918–19 in the United Kingdom, and this by an article from the pen of Dr. Herbert French on the clinical features of the epidemics of 1918–19, illustrated by coloured drawings and numerous charts. Appended is a long bibliography covering the years 1914–1920. Sir George Newman in his introductory note states that all observers are agreed as to the difference of the characters of the two waves, the first in June and July, 1918, the second in October and November. The first was of the three-day fever variety, not of virulent type, but remarkable in that it attacked youth especially. Damage to the capillary vascular system caused haemorrhages in the mucous and serous membranes, the respiratory tract, and the lungs; epistaxis was common. The condition is said in some ways to have resembled a bacteraemia, localized in particular in the pulmonary blood vessels, haemorrhage paving the way for secondary infections. The second wave was of a much more severe type. It was often attended by early acute infective pulmonary inflammation, while in other cases the symptoms early assumed the type of a virulent toxæmia or septicaemia. Sir Frederick Andrewes contributes a chapter on bacteriology, in which the part played by Pfeiffer’s bacillus is fully discussed. Speaking of the evidence obtained from the epidemic of 1918, he says that the position of Pfeiffer’s bacillus as the primary cause of the disease has been in no way strengthened. “Its case remains unproven, and the crucial tests to which it has been submitted

¹ Ministry of Health Report on the Pandemic of Influenza. Reports on Public Health and Medical Subjects. No. 4. 1920. H.M. Stationery Office. (10s. net.)

seem to indicate it rather as a secondary infection than as the primary 'materies morbi.' At the same time it cannot be asserted that, as a primary cause, it is wholly out of court. The evidence for a filter-passing virus as the primary cause of the disease is suggestive, but at present a final verdict cannot be given. The complications to which the epidemic has owed its abnormal fatality have been due to secondary infections in which Pfeiffer's bacillus and the haemolytic streptococcus have played a predominant part." Other chapters follow, including one on the general and special prophylaxis of influenza; here the hope is expressed that eventually vaccine prophylaxis may be placed upon a securer foundation than it yet possesses. Meanwhile, it is said that "the non-mystical methods which come within the scope of personal hygiene are those which both epidemiological and physiological research sanction." The second part of the volume presents an account of the incidence of influenza in Europe and the Western Hemisphere by Dr. R. Bruce Low, C.B., and of its incidence in Australasia and parts of Africa and Asia by Dr. S. P. James. The third part consists of a series of twelve papers reporting inquiries into different aspects of influenza as it occurred in this country. It contains results of a special study of the epidemic in Manchester by Dr. Niven and his colleagues, and by Dr. T. Carnwath, and a paper also by Dr. John Brownlee on the periodicity of influenza. We hope to refer in more detail to some of the articles in this interesting volume, which contains 600 pages, in future issues.

THE MACDONALD PRESENTATION FUND.

WE have received from Dr. Noy Scott, Honorary Secretary of the Plymouth Division of the British Medical Association, a letter expressing surprise that a larger number of members of the Association have not hitherto joined in the tribute of gratitude and regard to Dr. J. A. Macdonald afforded by the testimonial fund now opened. The only cause must be, he thinks, procrastination, for no member of the British Medical Association, nor any insurance practitioner, can be unaware of the great and self-sacrificing services Dr. Macdonald has for so many years rendered to the Association and the profession at large. The appeal for subscriptions to the presentation fund was published in full in the *JOURNAL* of July 24th, 1920. It was addressed to all members of the British Medical Association, and was signed by the President, the Chairman of Representative Meetings, the Treasurer, and by past Chairmen of Representative Meetings. After reciting briefly Dr. Macdonald's distinguished record of work for the profession, it proceeded: "In short, for the last seventeen years, whenever the Association has required exceptional services demanding sound judgement, devotion to the interests of the profession, and a commanding personality, it has called on Dr. Macdonald, and never in vain." The Council believes that members will desire to show their gratitude to Dr. Macdonald in a fitting and adequate manner. Subscriptions of any amount will be welcomed, but no individual subscription may exceed five guineas. Cheques should be made payable to "The Macdonald Presentation" and sent to the Medical Secretary, 429, Strand, London, W.C. 2.

A CANCER SERUM.

MENTION was made in the daily newspapers some months ago of a claim made by or on behalf of Dr. Glover of Toronto, to have prepared a "serum" which was alleged to have the power of curing or checking cancer. Last October the Toronto Academy of Medicine appointed a committee to inquire into the matter, and its interim report was presented on January 13th. The committee conducted its inquiry under two heads—experimental and clinical. As to the first, it was claimed that Dr. Glover had cultivated cancerous cells, and from them had cultivated and isolated an intracellular organism which he had found present only in cancer, and in every type of cancer.

It was further claimed that by inoculation of these cells and organisms cancer had been produced in a number of animals—pigeons, rats, mice, rabbits, guinea-pigs, and hens—and that by injection of cultures of these cells and organisms into the jugular vein of a horse a serum had been obtained which, when injected into the experimental animals, rendered them immune to inoculation by the cancer cells and organisms above mentioned. In other words, animals previously treated by the serum were immune, while those not so treated developed experimental cancer. The committee reports that Dr. Glover refused to permit representatives of the committee to visit his laboratories or to allow the committee to examine his cultures and experimental material at present available; he did not accede to a request to demonstrate his ability to cultivate cancer cells and organisms, nor did he demonstrate his ability to produce cancer by inoculation or to immunize animals against it. The committee therefore reports that it has no evidence to substantiate Dr. Glover's claims on the experimental aspect of the question. On the clinical side the claim was that the serum injected in cases of human cancer had been found capable of producing improvement or cure. The committee examined twelve of fifteen cases selected by Dr. Glover. It sought to obtain from the medical attendants of the patients confirmation of the diagnosis, and a statement as to the clinical condition of the patient before applying to Dr. Glover. It also obtained a list of cases treated in St. Michael's Hospital, only those cases being included which had received at least five injections. The committee also sought to obtain from Dr. Glover a complete list of the cases treated by him privately, and from Fellows of the Academy, from other practitioners, and from the hospitals, reports of the results of serum treatment in cases which had come under their observation. The committee's examination of the data from all these sources afforded it no evidence to warrant a hope that a specific cure for cancer has been discovered by Dr. Glover, or that a cure has been produced by the serum in any case definitely established as cancer. With regard to the further question, whether the serum produces improvement in cases definitely established to be cancer, the committee reports that it has not obtained evidence of any apparent improvement greater than that which may occur spontaneously in certain cases of cancer. It notes that good results are at times observed in cases supposed to be cancer, but in which the nature of the condition has not been established on incontrovertible evidence; in such cases, it is added, the usual conclusion of the medical attendant is that his diagnosis was wrong. In concluding its interim report, the committee states its readiness to examine any data Dr. Glover may decide to place before it, and to collaborate with recognized authorities who have already expressed their willingness to do so, or with others whom Dr. Glover himself may nominate. We gather that the committee will not go further into the matter unless Dr. Glover supplies to it details of his methods sufficiently definite to permit of a repetition of the experiments by independent workers.

SPIROCHAETOSIS ICTERO-HAEMORRHAGICA.

WORK in connexion with spirochaetosis ictero-haemorrhagica, formerly known as Weil's disease, and now often spoken of as infective jaundice, though it is one example only of a rather large group, has been mainly directed to its etiology, pathology, and epidemiology; and it must be admitted that the study of its clinical manifestations has been less conclusive, though Inada's (1917) correlation of the clinical course with the pathological changes must not be forgotten. In his recent clinical analysis of 55 cases Dr. J. A. Ryle,¹ who was in close touch with the disease during its prevalence on the Western front, has taken steps to redress the balance. Although some cases occurred in the base hospitals during the winter of 1915-16

¹ J. A. Ryle, *Quart. Journ. Med.*, Oxford, 1921, xiv, 139-170.

it was in the summer and autumn of 1916 that an epidemic, of probably not more than 200 cases all told, involved the British army in a confined section of the forward trench zone near Ypres. The infected areas were wet and ill drained, and the case incidence increased after a wet spell and decreased after dry weather. The absence of any further epidemics on the Western front may, like the considerable diminution in the number of rats, which are the accepted carriers of the infection, have been due to the great increase in the use of poisonous gas. Out of the 55 cases, 40, or 73 per cent., had jaundice, the remaining 15, or 27 per cent., being free from icterus; and the mortality of 3, or 5.4 per cent., was confined to the cases with jaundice, although non-icteric patients were often as severely ill as the icteric cases. The onset is characteristically sudden, and the initial febrile period lasts on an average ten days, being followed by a subnormal temperature for one to six days; 18 per cent. of the cases relapsed or showed recurrences, but the relapses were not necessarily accompanied by jaundice or grave signs; this last observation recalls Inada's very definite view that the return of fever is not due to spirochaetal activity, but to the reabsorption of spirochaetal toxins, and therefore is not a true relapse, and that the symptoms are merely those due to an elevated temperature and are not a repetition of those characterizing the original attack. Vomiting is a constant symptom of the disease and when frequent and persistent is a bad prognostic. The clinical features in the 55 cases show some differences from those of the disease in Japan, and also as described in pre-war literature; thus the mortality was much lower in France; the spleen, which was palpably enlarged in 10 per cent. of the Japanese cases and was a prominent feature in the descriptions given before the spirochaetal nature of the infection was discovered, was never found to be enlarged; increase in size of the liver was reported in 2 cases only; and herpes labialis, practically always haemorrhagic, occurred in 44 per cent. of the 55 cases. In other respects the recognized manifestations corresponded fairly well; albuminuria was noted in 58 per cent., acetonuria in 16 per cent., and pains in the legs in 44 per cent. In spite of the septicaemic nature of the disease, there was little evidence of any direct or permanent damage to the heart, and clinical evidence of cardiac dilatation was forthcoming in one case only. The average high limit of the pulse rate was 100, and a slow pulse, usually lasting for a short period, was common soon after the temperature had fallen. Epistaxis was noted in 9 cases, haemoptysis in 16; the extravasation of blood was referred to lysis of the capillary walls as a result of the septicaemic state, and not of the jaundice. The absence of haemoglobinuria and of increased fragility of the red blood corpuscles rendered haematogenous jaundice improbable, and the cause was thought to be obstruction in the radicles of the bile ducts; the possibility of excessive secretion of bile due to irritation of the liver cells is mentioned, but Brulé's contention that the jaundice is due to disordered function of the liver cells and is quite independent of obstruction is not considered. The differential diagnosis, especially of the early stages and of the cases without jaundice, in which trench fever proved the main stumbling-block, is fully discussed.

ANTHRAX FROM SHAVING-BRUSHES.

A CIRCULAR issued by the Ministry of Health draws attention to the recent occurrence of cases of anthrax in man, including some fatal cases, in which infection has been traced to the use of contaminated shaving-brushes. In the *JOURNAL* of January 3rd, 1920, p. 25, we recorded a protest by Dr. H. T. Maw against the importation of foreign-made (especially Japanese) shaving-brushes because of the insanitary conditions under which they were manufactured, and the possibility of infection

by anthrax; special reference was made also by Dr. Maw to other brushes used for medical and toilet purposes, such as throat-brushes and tooth-brushes. In consequence of the number of random samples found infected, an Order in Council was issued in February, 1920, prohibiting the further importation of Japanese shaving-brushes into this country. Steps were taken to secure the destruction of brushes from consignments known to be infected, and all importers of and wholesale dealers in Japanese shaving-brushes were warned of the possible danger to persons becoming possessed of these brushes. Owing to the difficulty of tracing brushes imported before the prohibition took effect there is reason to believe that there must still remain in the hands of retailers a considerable number of shaving-brushes of Japanese origin which may be infected. Medical officers of health are asked, therefore, to communicate with all retail chemists and other dealers in shaving brushes in their districts and warn them of the serious results which may follow from the distribution of Japanese shaving-brushes which they may still have in stock. Such brushes should either be destroyed or securely wrapped up and returned to the wholesale dealers from whom they were obtained, with an accompanying explanation. An improved method for the partial disinfection of shaving-brushes before use is recommended by the Ministry of Health; complete sterilization is impracticable, as disinfection will not affect spores embedded in the handle of the brush. The brush should first be thoroughly washed with soap and warm water containing a little washing soda, and allowed to stand for half an hour in a warm solution of formaldehyde (1 part of 40 per cent. formalin and 16 parts of water—a 2½ per cent. solution of formaldehyde); then it should be allowed to dry. In regard to the treatment of a case of anthrax, it is now recognized that the best method is physiological rest of the part affected, combined with intravenous injection of anti-anthrax serum—60 to 80 c.cm. on the first day, and 60 c.cm. on the day following. Subcutaneous injection into the abdominal wall of 30 c.cm.—repeated if necessary on successive days—has apparently been successful in many cases. Excision is now no longer recommended as an adjunct to the serum. The use of normal ox serum, referred to in a leading article in our issue of December 4th, 1920, has not yet had sufficient trial to displace treatment by anti-anthrax serum.

"JOURNAL OF LARYNGOLOGY AND OTOTOLOGY."

FROM the beginning of the present year the monthly *Journal of Laryngology, Rhinology, and Otolaryngology* has, with the alteration in its title given above, entered upon a new phase in its existence. Founded as the *Journal of Laryngology and Rhinology* thirty four years ago, by Morrell Mackenzie and Norris Wolfenden, it has now been purchased from the publishing firm who owned it by members of the profession, for whom it will in future be published by Messrs. Oliver and Boyd, Edinburgh. No radical changes are to be expected in the scope and policy of the journal, but it is hoped that under the new conditions it will appeal to all medical men interested in otolaryngology, not only in the British Isles, but in the Overseas Dominions and in America. Laryngology as a special branch of surgery was cradled in Britain, and most of the great advances made in it have been of British origin. With the increasing number of workers in the speciality further advances in knowledge are to be anticipated, whether sought in the laboratory or by clinical observation in the out-patient departments and wards of hospitals. We look confidently, therefore, for a still larger and more valuable output of original contributions in the pages of the *Journal of Laryngology and Otolaryngology*. The January number reflects great credit on the new management, and on the editors, Dr. A. Logan Turner and Mr. J. S. Fraser.

CHINESE HONOURS FOR MEDICAL MISSIONARIES.

THE Chinese Government has conferred the Order of the Chia Ho, 5th Class, upon three British medical missionaries—Drs. Davenport, Cousland, and Gillison. Dr. Cecil J. Davenport was President of the China Medical Missionary Society during three years of the war, and recently presided at the Medical Conference held in Peking. He receives the Chia Ho for pioneer work in Chungking and Wuchang, and also for his work since 1904 as chief of the Shantung Road Hospital. He has seen thirty-one years' service in China. Dr. Philip B. Cousland was formerly at Chaochowfu, Fukien Province; he is now engaged in translating foreign medical books into Chinese and in helping to form a Chinese medical terminology. The decoration is bestowed for long and useful service in pioneer medical and literary work during thirty-seven years in China. Dr. Thomas Gillison worked for nearly thirty-five years in Hankow, and is now engaged in teaching and literary work in the Shantung Christian University, Tsinan. The award is in recognition of pioneer medical work in Central China, and of educational and literary work in Hankow and Tsinan.

A MEETING of Lord Cave's Committee on Voluntary Hospital Finance was held on February 2nd at the Ministry of Health, when evidence was given in the morning by Sir Cooper Perry and Mr. Maynard on behalf of the King Edward VII Hospital Fund, and in the afternoon by Mr. Verity, Chairman of Charing Cross Hospital. On February 3rd Mr. Vernor Miles gave evidence on behalf of the small general hospitals in the London area of the British Hospitals Association.

DR. PERCY KIDD, consulting physician to the hospital, has been elected Schorstein Memorial lecturer for 1922 at the London Hospital Medical College. The lecturer for this year is Dr. A. G. Gibson of the University of Oxford, who will give his lecture on chronic inflammatory diseases of the spleen on June 3rd.

DURING the twenty years that the Nobel Prize has been awarded there have been 101 prize winners, consisting of 23 Germans, 20 Frenchmen, 9 Englishmen, 8 Swiss, 6 Americans, 6 Swedes, 5 Dutch, 5 Danes, 4 Belgians, 4 Italians, 3 Austrians, 2 Norwegians, 2 Russians, 2 Spaniards, 1 Scotsman, and 1 Indian; 97 were men, 28 have died.

ROYAL MEDICAL BENEVOLENT FUND.

At the meeting of the Committee held on January 11th, 1921, twenty-four cases were considered, and £255 voted to eighteen applicants. The following is a summary of some of the cases relieved:

Daughter, aged 63, of M.R.C.S.Eng. who died in 1874. Applicant has supported herself for some years by the teaching of drawing and painting, but owing to age and deafness is now unable to obtain pupils. Only certain income £26 a year and a gift from friends of £10. Rent £20 per annum. Voted £18 in twelve instalments.

Daughter, aged 44, of F.R.C.S.I. who died in 1899. Applicant shares a cottage with a friend, and they make a small income by taking boarders. Total income 1920, £75. Relieved once, £10, January, 1920. Voted £10.

Widow, aged 53, of M.R.C.S.Lond. who died in 1911. Applicant earns her own living by giving music and singing lessons. Her daughter, aged 26, helps her aunt, with whom she lives, but owing to a breakdown the doctor orders her away for a rest, and applicant asks for help to defray the expense. Relieved six times. Last time £10 in two instalments, December, 1918. Voted £15 in two instalments.

Daughter, aged 43, of F.R.C.S.I. who died in 1899. Applicant shares house with a friend, and they derive and share a small income from letting rooms. Applicant's total income during last twelve months, £40. Relieved once, £10, January, 1920. Voted £10.

Subscriptions may be sent to the Honorary Treasurer, Sir Charters J. Symonds, K.B.E., C.B., F.R.C.S., at 11, Chandos Street, Cavendish Square, London, W.1.

The Royal Medical Benevolent Fund Guild is overwhelmed, in these days of exorbitant prices for clothing and household necessities, with applications for coats and skirts for ladies and girls holding secretarial posts, and suits for working boys. The Guild appeals for second-hand clothes and household articles for the benefit of the widows and children who in happier times would not have needed assistance. The gifts should be sent to the Secretary of the Guild, 43, Bolsover Street, W.1.

Scotland.

THE CONSULTATIVE COUNCIL'S MEDICAL SERVICE SCHEME.

THE Scottish Committee of the British Medical Association has referred the report of the Scottish Medical Consultative Council to the Divisions in Scotland. As will have been seen from an analysis of the report published in our columns of December 11th it embodies a medical service scheme. Before formulating any statement on the scheme the Scottish Committee will await the replies of the Divisions, and though there will be a meeting of the Committee on February 10th it is not likely that many replies will have been received by that date. The Committee, however, may think it necessary to take some notice of the letter criticizing the scheme which the Medical Guild has circulated to the profession in Scotland. The letter, which is signed by the president of the Guild, Emeritus Professor F. M. Caird, and the honorary secretary, Dr. Frederick Porter, directs particular attention to the fourth recommendation of the Consultative Committee, which advised that "the present medical service for the insured should be *expanded*, so as to provide everything that is still necessary to make it adequate and complete, and *extended* so as to include within its scope the dependants of the insured, all persons (including dependants) of the same economic status as the present insured class, and all now entitled to medical service under the existing Poor Law." The Guild expresses the view that this means "that every tradesman, sloopkeeper, and all others with incomes under £250 per annum, along with their wives, children, and others who may be dependent on them, will be provided with a State doctor." In many districts, including small towns and villages, this will, it is considered, leave very few private patients. As the State family doctor will have over him a junior and senior district medical officer to supervise his work, his position, it is argued, will "be lowered to the status of a scullery-maid in a State medical kitchen." The Guild has drawn up a memorandum, which it asks its correspondents to approve. The memorandum contains these passages:

"The family doctor is to be a State doctor, remunerated, presumably at a contract rate. The patients are to be State patients; they are no longer to be the doctor's private patients. The doctor becomes a departmental official, and the patient a name in the departmental directory.

"It is further proposed to have two grades of officials below the doctor. The one is the State nurse, who will enter the sick-room as a State servant, not with the beneficent influence of the present district nurse to help as she finds it practicable. The other is the health visitor, who is to act as a sort of State mother to the family, and is to officially instruct the mother how to treat her children. In the event of sickness, if the official opinion be that the house is too small, the sick person is to be removed to a 'hospice' or to 'recovery rooms,' which it is proposed to provide all over the country.

"There is no attempt to estimate the cost of this scheme, but it must be very great. When the country is groaning under the enormous burdens of the war, the proposals can only be regarded as monstrous."

The memorandum expresses the view that the State should cease to interfere with medical attendance on sick people other than those who belong to the necessitous classes, so long as the sick are not a danger to the community by reason of infectivity. A letter by Dr. Buist on this subject is printed in the SUPPLEMENT.

SCOTTISH REGIONAL HOSPITALS COMMITTEE.

A Regional Committee in Scotland of the British Hospitals Association was formed at a meeting of hospital managers and administrators held in Glasgow on January 25th. Colonel D. J. Mackintosh, C.B., M.V.O., Medical Superintendent, Glasgow Western Infirmary, occupied the chair. The Regional Committee, it was pointed out, would be an integral part of the British Hospitals Association, and only those who joined the parent body would be eligible for membership. The Committee will consider matters affecting voluntary hospitals, and take such steps to safeguard their interests as may be considered necessary. Colonel J. A. Roxburgh was appointed chairman and Dr. D. Campbell Suttie honorary secretary. An executive committee composed of representatives of groups of hospitals was appointed.

CENTRAL MIDWIVES BOARD.

At a meeting of the Board held in Edinburgh Sir Halliday Croom, in a valedictory address on his retirement from the Board, thanked the members for the loyal support he had received as chairman, and referred to the pleasant and harmonious way in which the work had been carried out. On the motion of Dr. A. Campbell Munro, seconded by Sir Archibald Buchan-Hepburn, a hearty vote of thanks was accorded to Sir Halliday Croom for the efficient manner in which, during a period of five years, he had discharged the important duties of chairman of the Board since its formation. The Board also expressed its appreciation of the able and valuable services rendered by Mr. D. L. Eadie, the secretary. The constitution of the new Board is announced in the SUPPLEMENT this week at p. 31.

Ireland.

VISIT OF SIR GEORGE MAKINS TO BELFAST.

SIR GEORGE MAKINS was entertained to dinner by the Council of the Ulster Medical Society and a few friends on the evening of January 28th; he also was shown over the hospitals, and on Saturday, 29th, was taken down to the well-known golf links at Newcastle to try his skill with some of the local medical talent. It gave all these who had met Sir George in France the greatest pleasure to welcome him to the North of Ireland, and his reputation had been spread by those who returned after serving, so that the warmth and heartiness of his reception was general, and his visit was greatly appreciated.

ULSTER MEDICAL SOCIETY.

The sixth meeting of the session was held in the Medical Institute, Belfast, on January 27th. The President, Dr. Thomas Houston, occupied the chair, and there was a large attendance. The President presented the Certificate of Honorary Fellowship to Major-General Sir George Makins, G.C.M.G., ex-President Royal College of Surgeons of England. He referred to the great services of Sir George in the war; to his very kindly relations to the hospital at Etaples with which so many of the Belfast Medical School were connected; to his judicial and convincing contributions to the Medical Society at Etaples; and to the charm and sympathy of his character, which endeared him to all who were fortunate enough to work under him. The Society had not many honours to bestow, but they asked his acceptance of their highest honour, of which they were somewhat jealous. There were only nine on the list, and in former times it contained such names as Lord Lister. Sir George Makins, in thanking the Society, referred to his indirect connexion with Belfast through the late Sir William MacCormac, whose dresser he had been, and with whom he worked for many years in close personal friendship, and at whose house he had met many Belfast people. He then gave his address on "Injuries to the heart." He referred to the experience in civil life and at the front during the war; to the dangers of shock, secondary infection, injury to valves and to the vital strands of muscle; the small amount of blood in the pericardial sac was astonishing. Illustrations were thrown on the screen of many specimens, and details given of many cases, as the "hydraulic explosion effect" in a full heart or the "burst paper bag." He then dealt with the symptoms and with the great difficulty of the interpretation of the curious and rare physical signs, such as the "tapping" sound, or click, supposed to denote a foreign body in or near the wall of the heart. In cases of injury to the heart, the diagnosis might be very simple or very difficult; the prognosis of operation on the actual heart was 50 per cent. mortality; higher figures were given. The indications for operation and the technique were referred to. Professor Sinclair proposed, and Dr. J. Walton Browne seconded, that the heartiest thanks be given to Sir George Makins for his most interesting and instructive address. This was passed by acclamation.

WOUNDED PERSONS IN DUBLIN HOSPITALS.

Notices have been served on the authorities of all Dublin hospitals requiring them to furnish daily to the military authorities a list of patients admitted suffering from

bullet wounds. The Crown forces can at present enter the hospitals at any time, day or night, and have been doing so. In the circumstances the hospital authorities consider it invidious to furnish the return required by the military. The following is the text of the Order:

To the Secretary, Hospital.

By virtue of the powers conferred on me under Regulation 53 of the Restoration of Order in Ireland, Regulation 1, the undersigned, being a Competent Military Authority under the said regulations, do hereby order you, the secretary, being the person in charge of the hospital, to furnish to me (in writing) the names and descriptions of all persons admitted to your hospital who are or are suspected to be suffering from wounds caused by bullets, gunfire, or other explosives, together with such particulars and information concerning them as may be within your knowledge. Such information is to be furnished by you daily to me at Headquarters, Dublin District, Lower Castle Yard, Dublin. Failure to comply with this order will render you liable to be proceeded against for an offence against the Restoration of Order in Ireland Regulations.

R. D. F. OLDMAN, Colonel Commandant,
Commanding Dublin District,
Competent Military Authority,
Lower Castle Yard, Dublin.

Mr. H. S. Meade, Surgeon to St. Vincent's Hospital, Dublin, has stated that the Order was dead against the etiquette of the profession, and has declined personally to make such reports. His surgical colleague, Mr. J. S. McArdle, in an interview reported in the *Freeman's Journal*, said that the order would indicate that the surgeons might betray confidences in their own hospitals, because it was only they, not the secretary, who could learn the particulars of any case placed under their care; he expressed the opinion that no power on earth would make Irish surgeons go back on the responsibilities which have grown with their advances to the higher walks of the profession. Dr. Sigerson, in an interview, recalled the fact that during the revolutions in Napoleon III's time the French hospitals refused to do what the Irish hospitals were now asked to do. The French hospitals refused to give the names of revolutionaries who were being treated.

Amongst the recent arrests by the Crown forces in Ireland are a number of medical practitioners, including Miss Ada English, M.D., assistant medical officer, District Asylum, Ballinasloe. Dr. James Ryan, who graduated in the National University in 1917, was arrested some months ago, and, so far, has not been brought before a court-martial.

England and Wales.

PAYING PATIENTS AT A LIVERPOOL POOR LAW INFIRMARY. FROM a communication made to the *Liverpool Courier* by Mr. Cleaver, clerk to the West Derby Union, we learn that a large number of paying patients have for several years been admitted to the hospitals in the West Derby Union, either as emergency cases, or because the patient could not obtain admission to a voluntary hospital or was unable to pay the charges of a private nursing home. Recently the committee of the Mill Road Infirmary received a letter from Dr. W. B. Bennett, chairman of the Liverpool Branch of the Middle Classes Union, asking that definite provision should be made for such patients. The board of guardians agreed on January 26th that as an experiment arrangements should be made for the admission to the infirmary of patients resident in the West Derby Union, either upon the recommendation of the patient's private medical attendant or upon personal application, subject to the discretion of the medical superintendent, who would have full power to grant or refuse admission. The arrangements provide for the admission of acute medical or surgical cases resident within the area of the union, either on the recommendation of their private medical practitioner or on the application of the patient or his friends. Such patients will pay three guineas a week, and their private medical attendant will be allowed to consult with the medical staff of the infirmary, but no interference will be allowed either in the treatment or nursing of such patients. The infirmary is administered by a medical superintendent, who is assisted by three resident medical officers; there is also a visiting staff, including a visiting surgeon, dermatologist, ophthalmic surgeon, and dental surgeon. It does not appear

how far these proposals accord with the wishes of the local practitioners, who may or may not regard them as valuable to the community, but they seem to differ considerably from any policy so far outlined by the British Medical Association.

PRESENTATION TO DR. BARTON, OF BLACKPOOL.

It had been felt for some time past by the medical practitioners of Blackpool and district that some tangible appreciation should be shown to Dr. H. T. Barton for his valuable services rendered to the profession locally for many years past. Dr. Barton has acted as secretary to the Local Medical Committee since the inception of the Insurance Act, and it is mainly due to his energy and his wide knowledge of the medical sections of the Act that the local practitioners have found insurance matters working so smoothly in this district. Dr. Barton also acted as secretary to the Local War Emergency Committee, and was of the greatest assistance to that committee also. With this object in view, a large number of medical men met at the Queen's Hydro, Blackpool, on December 15th last. After an excellent dinner, Dr. Godley (chairman) spoke of the esteem and regard with which Dr. Barton was held by the profession locally and of his untiring energy in the interests of the profession, of how he put aside his own work, often at great inconvenience, to serve the interests of an individual medical man or the profession generally. Nothing was too much trouble for him. When the interests of the profession were at stake, either in London or in a distant town, he would rush off to the meeting and report fully at the next local meeting. Dr. McIntosh, in presenting Dr. Barton with a handsome silver salver and a fitted dressing-case, spoke in felicitous terms of the great amount of work done by Dr. Barton for the profession.

ONODI COLLECTION OF NASAL ANATOMY.

THE Royal College of Surgeons of England have accepted the gift of this valuable collection from the Onodi Subscription Fund Committee. The specimens will be mounted and catalogued by the College, and when completed each subscriber will be presented with a catalogue.

The list of subscribers is as follows:

- £52 10s.—Honorary Staff Central London Ear, Nose and Throat Hospital.
 £26 5s.—Honorary Staff, Throat Hospital, Golden Square.
 £20.—Sir William Milligan.
 £10 10s.—Sir St. Clair Thomson, Sir James Dundas Grant.
 £10.—Messrs. Mark Howell, A. Logan Turner.
 £5 5s.—Sir John Bland Sutton, Sir F. Bell Longhurst, Messrs. W. M. Mollison, Norman Paterson, Somerville Hastings, W. Douglas Harmer, F. A. Rose, A. Brown Kelly, Tyrrell Grey, W. G. Howarth.
 £5.—Messrs. D. R. Patterson, Thelwall Thomas, A. J. Hutchison, Herbert Tilley, H. Lambert Lack.
 £3 3s.—Sir Charles Ballance, Sir Charles Ryall, Dr. William Hill, Messrs. Herbert J. Marriage, G. W. Wilkinson, J. F. O'Malley, A. L. Macleod, C. A. Parker, E. D. Davis, W. G. Spencer, W. Jobson Horne.
 £3.—Messrs. E. A. Peters, Charles J. Heath.
 £2 2s.—Sir William Arbuthnot Lane, Sir Frank Colyer, Sir Harold Stiles, Sir Anderson Critchett, Messrs. George Cathcart, W. S. Syme, Ranson Pickard, W. H. Dolamore, H. Watson Turner, Albert A. Gray, Ernest Clarke, E. Treacher Collins, C. Ernest West, Dr. James Taylor, Mr. T. Guthrie, Sir G. Sims Woodhead, Dr. George Morgan, Dr. John Eyre, Dr. P. Watson-Williams, Messrs. W. H. MacMullen, Philip Franklin, Robert P. Mathers, H. J. Waring.
 £1 1s.—Mr. V. I. Sanzgiri, Dr. W. Ainslie Hollis, Messrs. William Appleyard, R. P. Rowlands, J. H. Badcock, Russell Barrett, Henry Peterkin, George E. Waugh, Wilfred Glegg, Sir D'Arcy Power, Messrs. H. O. Dickin, Henry Smurthwaite, Dr. Peter Macdonald.
 £1.—Messrs. Thomas Rogers, William Rushton.
 10s.—Mr. Andrew Ellis Wynter.
 5s.—Mr. George James.

In November 593 cases of plague occurred in Java, all of which were fatal, as compared with 637 in October.

THE Board of the Royal Salop Infirmary has adopted a resolution recording the irreparable loss sustained by the death of Mr. Arthur Jackson, who for nearly thirty years was honorary surgeon and subsequently honorary consulting surgeon to the Infirmary.

A SPECIAL post-graduate course, lasting two weeks and consisting of thirty lectures, will be held at Easter, commencing on March 21st, at the Medical Clinic, Hôtel-Dieu, Paris, on "Recent ideas on diseases of the liver (including diseases of the biliary passages and the pancreas)." The fee is 150 francs, and particulars may be had from the Secretary of the Faculty of Medicine, University of Paris. Further post-graduate courses are, it is announced, to be carried on later in the year: in July, on diseases of the digestive system, and in September a practical course on the application of laboratory methods to diagnosis.

Correspondence.

"MINUTE BODIES" IN EPIDEMIC ENCEPHALITIS.

SIR,—With reference to Dr. C. Da Fano's interesting and suggestive "Preliminary note on the histo-pathology of epidemic (lethargic) encephalitis" in the *JOURNAL* of January 29th, 1921, I write to say that within the last few weeks, while studying the pathological histology of a series of cases of encephalitis, I have observed structures which appear to be identical with the "minute bodies" described by him. They were first noticed in sections stained by the Nissl method, and have been found in each of three cases of the series examined by this method. The remainder of the cases have not yet been investigated. The bodies were seen in the nerve cells of the pons, optic thalamus, mid-brain, cortex, and also in the interstitial tissue. They appear to occur in comparatively few cells and their detection requires systematic search. Their presence is associated with considerable degenerative changes, and I cannot recall observing them in cells of normal appearance.

In the main the appearances found agree with those described by Dr. Da Fano, though I have not met with such large numbers in a nerve cell as shown in his Fig. 1. Until reading his article I had formed no opinion as to the significance of these bodies, though I had come to the conclusion that they were morphologically distinct from the pigmentary granules commonly found in the nerve cells in encephalitis.—I am, etc.,

A. F. BERNARD SHAW,
Pathological Department, College of
Medicine, Newcastle-upon-Tyne.

January 30th.

WHAT IS A SYMPTOM?

SIR,—In his paper published in the *JOURNAL* of January 29th, Sir James Mackenzie discusses "The Relations of Symptoms to Disease."

All those who are following Sir James's valuable work—and they are many—will want to know what meaning he attaches to the term "symptom." I therefore venture to ask what precisely that meaning is.—I am, etc.,

London, W., Jan. 29th.

HARRY CAMPBELL.

THE PRODUCTION OF SYMPTOMS.

SIR,—As one who believes that Sir James Mackenzie, in enunciating, in the *JOURNAL* of January 29th, the law that the vast majority of the symptoms of disease are disturbances of normal reflexes, has done for medicine what John Dalton did for chemistry in 1808, I desire to draw attention to certain aspects of his theory in its relation to pulmonary tuberculosis. The symptoms of this disease are not only in harmony with Sir James Mackenzie's law, but also extend in some measure its detailed application. In the fourth group of diseases, represented by "a confused heap of symptoms in which it is not possible to obtain a suggestion as to their relation to a common cause," Sir James Mackenzie places—

"all chronic diseases, even though the ill health is definitely due to damaged organs which can be recognized by physical signs—as arterio-sclerosis, chronic heart disease, chronic kidney disease, and even consumption and cancer. The reason for including these is that they are probably secondary diseases, the original cause not being capable of recognition."

As regards pulmonary tuberculosis, I presume that this sentence refers to the symptoms of the disease, and implies that these symptoms cannot be explained in relation to the morbid changes in the structure of the lung. Even if it be so, I submit that tuberculosis should not be included in this group. Many years ago I learnt from Sir Robert Philip that pulmonary tuberculosis is not a local disease of the lung, but is a general toxæmia affecting all systems of the body, and due to successful infection by the tubercle bacillus; and I now suggest that the symptoms of this disease may be explained by the effects of toxæmia on all reflex arcs of the body. Further, I submit that in this instance at all events it is not possible to differentiate between a stimulus acting on the receptor (A), and an agent altering the receptivity of the nervous mechanism (B) and the effector (C) of the symptom.

These propositions are easily illustrated. A very early symptom of pulmonary tuberculosis may be uneasy sensa-

tions in the stomach during digestion, associated with hypersensitiveness of the gastric mucosa—that is, of receptor (A) due to toxæmia. Later on, tuberculous toxins produce an irritability of the vagus nerve, and an entire reflex arc is affected. Food irritates the hypersensitive stomach (A), and this excites the vagus (B), with the result that the ingestion of food is followed by a reflex secretion of mucus in the respiratory tract (C). After meals the patient has coughing, hawking, and retching.

This symptom is explained by the increased irritability of a reflex arc, every portion of which is affected. Most probably it is but the exaggeration of a normal reflex whereby the ingestion of food is followed by an increased flow of saliva. Apart from tuberculosis, I have noted that when this reflex is even slightly exaggerated the area over which it operates is extended, and that there is an increased flow of secretion in the upper respiratory tract, particularly in the nasopharynx, and even from the lacrimal glands. Although the reflex arc is in other symptoms of tuberculosis may not be apparent at present, many true things have been discovered by analogy, and the study of Sir James Mackenzie's law will certainly lead to the recognition of many reflexes hitherto unobserved.—I am, etc.,

London, S.W., Jan. 29th.

HALLIDAY SUTHERLAND.

TREATMENT OF THE PRE-OPERATIVE STAGE OF ENLARGED PROSTATE.

SIR,—I agree with Dr. MacMunn that there are cases with prostatic symptoms that do not require operation.

In the address to which he refers I did not set out to discuss all cases that might or might not require operation, and the only words which might convey this impression occur in a heading, "Indications for operation," that was slipped in after the typescript left my hands and was unnoticed by me in reading the proofs. The text below this, however, leaves no doubt that the only indications are those of operation as opposed to catheter life, and not the general question of indications for operation in enlarged prostate.

The theme that I developed, and that I hoped was clearly stated, was that all patients complaining of prostatic symptoms should be investigated, that the investigation should be thorough and should not be confined to the urinary tract, and that patients with enlarged prostate should not be allowed to drift into renal inefficiency from back pressure or urinary sepsis from catheterization.

I cannot see how Dr. MacMunn gets the impression that I wish to operate on all cases complaining of prostatic symptoms or on all cases where the prostate is at all enlarged provided they are fit to stand an operation. The majority of cases of enlarged prostate that I have observed have been steadily progressive in regard to the symptoms, or the ascertainable size of the prostate, or the effect on the urinary tract, or on all of these counts. There are cases in which the enlargement seems to stand still; and if this apparent arrest occurs at a period before the obstruction has produced residual urine, there is no harm, so far as the urinary tract is concerned, in waiting, provided the patient keeps under observation. But one remembers cases where the patient has received the assurance that the condition was stationary, and, in default of an increase or with only a small increase in the symptoms, has come up after some years for examination with a "silent" prostate, chronic distension of the bladder, and serious damage to the kidneys; or, on the other hand, the once simple enlargement now shows an area of hardness that leaves no doubt as to a malignant change.

I have asked for nothing more than that these possibilities be placed before the patient, and he should make his own decision. He has in any case the right to know that such eventualities may occur.

In regard to nocturnal frequency after the age of 50, I think if Dr. MacMunn will read this paragraph again, he will see that I recommend that such cases should be investigated, not that they should be operated on because they have this increased frequency.

I am sure Dr. MacMunn does investigate these cases, for he has evolved a theory to explain the symptom. I do not doubt that in his investigation he finds a good many cases which he would classify under some other heading than "waning of the vesical sphincter."—I am, etc.,

London, W., Jan. 25th.

J. W. THOMSON WALKER.

SIR,—Mr. Thomson Walker's important contribution in the *JOURNAL* of January 15th emphasized the possibility of avoiding various special risks. Mr. MacMunn's letter in your issue of January 22nd very properly goes a stage further back, and raises the most important question of all. *What can be done to diminish the number of cases requiring operation?*

Do we know the cause of the enlargement? Certainly a large proportion of those cases coming to us for operation are adenomatous. Is there a gradual failure of balance of internal secretion as old age comes on? Is there any material evidence in favour of the use of orchitic extracts to combat senile prostatic enlargement? Can anything effective be done by bladder hygiene and the voluntary, thorough, regular emptying of the organ? Chronic inflammatory enlargement may respond to massage, but adenomatous hypertrophy can hardly be expected to do so.

What influence has diet? In Kashmir the Hindus, who are vegetarians, enjoy a remarkable immunity from enlarged prostate. In the Mohammedans, who are meat eaters, prostatic trouble is not rare. In advanced cases with persistent retention I have frequently operated, with the usual beneficial rejuvenating result. But how many successful cases are to be weighed in the balance against one death, whether from embolism or other cause? It is true that the results would be greatly improved if we operated before catheter life had begun. All surgeons of experience, however, know that many cases do recover after a period of catheterization and live in comfort to a good old age. Few would therefore advise routine operation after a first attack of retention.

Prostatectomy has won an honoured place in surgery, due in no small measure to the work of Sir Peter Freyer, Mr. Thomson Walker, and other distinguished surgeons. A still greater advance will be made when we know with more precision *how to arrest the enlargement of the prostate before it produces serious results.* The disease is all too common. Is it too much to hope that some of your readers may be able to contribute to our knowledge in this respect?—I am, etc.,

Dromley, Kent, January 30th.

ERNEST F. NEVE.

THE PREVENTION OF VENEREAL DISEASE.

SIR,—The dispute which is being waged in these pages on the subject of prophylaxis in venereal disease has long ago lost the characteristics of a scientific discussion, and is rapidly acquiring those of a family quarrel. What is more distressing still is the fact that this quarrel has spread beyond the confines of the medical into the lay press, so that the noise and clamour of it are plainly heard by the man in the street. Small wonder that the latter has shrugged his shoulders and lost his confidence in those to whom he is entitled to look for leadership and advice.

Has not the time come for emphasizing points of agreement rather than those of dispute? Two societies exist for the purpose of combating venereal disease—the National Council for Combating Venereal Diseases and the Society for the Prevention of Venereal Disease. On their lists of membership appear names that command respect and consideration for the opinions that each society has advanced. No one who has seen the excellent work achieved by the National Council for Combating Venereal Diseases can consider it an effete body that has sacrificed every practical measure to a sentimental fetish. No one who has read the list of membership of the Society for the Prevention of Venereal Disease can suppose for one moment that such eminent men would deliberately support a policy that is calculated to undermine the moral welfare of the community. In spite of the noise and dust raised by various extremists, it is certain that there exists a considerable sphere of activity common to both societies.

It is only over the question of prophylaxis that the split has arisen. The Society for the Prevention of Venereal Disease is convinced that the packet system has been instrumental in materially reducing the incidence of venereal disease in the services, and believes that its adoption by the civil community would be equally productive of good. The National Council for Combating Venereal Diseases, on the other hand, is dissatisfied with the results of prophylaxis in the services, and does not in any case believe that the adoption of the packet would be productive of

good when applied to the civil community. Each of the societies has put forward statistics upon which the other has cast doubts, and each has arrived at conclusions which are endorsed by experienced authorities. Where does the truth lie? It is difficult, or impossible, at the moment to say. Statistics can be found to prove or disprove most of our prejudices, and our attitude towards the question of "packets for the people" must for the present be based on personal opinion rather than established fact. The centre of truth, like the centre of gravity, lies somewhere between the two extremes. It is possible that the National Council for Combating Venereal Diseases has underrated the importance of prophylaxis in the campaign against venereal disease. It is equally possible that the Society for the Prevention of Venereal Disease in its enthusiasm for a neglected remedy has tended to regard it as the "single measure that will cure our ills."

There is work for all in the campaign against venereal disease. The National Council for Combating Venereal Diseases is doing yeoman service in its educational campaign, and in its agitation for the provision of free and adequate treatment for venereal disease throughout the world. The Society for the Prevention of Venereal Disease is convinced of the success of prophylaxis in the army and believes that its extension to the civil population will be equally effective of good. A campaign in favour of packets is the logical outcome of these views.

Let each of the societies work along the line it has chosen, but let it be recognized that until further data are available it is upon personal opinion rather than upon verified fact that conclusions must rest.

Lastly, may I put forward a suggestion that has already been made? Is it asking too much that members of the two societies should arrange to meet? Surely it is better that differences of opinion should be amicably discussed in a meeting of medical men rather than be made the subject of a bitter and somewhat tedious correspondence in the press. I believe that if such a meeting could be arranged a vast amount of common ground would be found to exist between the two societies, and that a satisfactory working agreement could be arrived at on this thorny subject of prophylaxis.

Apologizing for trespassing on your valuable space, I am, etc.,

London, W.1, Jan. 26th.

KENNETH M. WALKER.

SIR,—Mr. E. B. Turner is not backward in taking advantage of his position of reviewer of Sir Archdall Reid's book to deliver an attack upon those with whom he does not happen to agree. He emphasizes the time-worn fallacy that the sexual instinct can be suppressed by terrorism. He has such a poor opinion of that portion of his fellow countrymen whom he calls "the populace" that he thinks that if it is entrusted with the ripe knowledge of such a practical authority as Sir Archdall Reid, fornication will be more practised than ever. He ignores the fact that in spite of his own lectures venereal disease is still rampant, and he has nothing to suggest but to persevere in a policy which is a proved failure.

It is interesting to note that he admits that many people will be protected by prevention; but he is of opinion that knowledge of self-disinfection will increase promiscuous sexual indulgence. This cannot be proved. But the admission and the opinion disclose the frame of mind, which is the real centre of the opposition to the teachings of science. It is the frame of mind that would apparently prefer that the many who would be protected should be visited with venereal disease rather than face the possibility that a certain number of people might gratify the sexual instinct who might otherwise have abstained.

Your readers must be aware of the cleavage between the two schools of thought. The one school would deny knowledge to their fellow countrymen; the other would give them access to it. Mr. Turner seems to think that knowledge ought to be and can be concealed from "the populace" by a policy of suppression. Other of your correspondents would appear to think that science can be defeated by ridicule.

The Society for the Prevention of Venereal Disease stands for access to knowledge. This knowledge is already public property. It cannot be suppressed. It is the duty of the State to see that it is scientifically applied, and we

believe that our fellow countrymen have enough intelligence and self-control to be entrusted with it.—I am, Sir, your obedient servant,

London, W., Jan. 31st.

WILLOUGHBY DE BROKE.

* * * In a further letter, written on behalf of the Executive Committee of the Society of which Lord Willoughby de Broke is president, Dr. H. Wansey Bayly wishes to point out that Mr. E. B. Turner's review of Sir Archdall Reid's book, printed in our last issue, "must not be taken as an impartial review by an unbiased reviewer outside the sphere of the controversy." Where such a person is to be found we do not know. As many of our readers are well aware, Mr. Turner is the representative of the British Medical Association upon the National Council for Combating Venereal Diseases, and his personal position in the present controversy is made sufficiently plain in the course of his review.

SIR,—In Mr. Turner's review of Sir Archdall Reid's book, he says:

Miss Ettie Rout, a member of the Grand Committee of the Society for the Prevention of Venereal Disease, crystallizes the policy of that society in the following words, quoted by the Archbishop of Canterbury in the debate in the House of Lords: "Every boy and girl in our parishes must be provided free with the outfit which will make them secure, and when you have done that all will be right—go with clean people and you will be clean."

Please permit me to explain that these words were never said or written by myself. They were misquoted in the first instance in the House of Lords by the Archbishop of Canterbury and repeated in Sir Archdall Reid's book, from which Mr. Turner has quoted between inverted commas.—I am, etc.,

London, W., Feb. 1st.

ETTIE A. ROUT.

THE BRADFORD MUNICIPAL HOSPITAL.

SIR,—Dr. Slater finds fault with my term, "obsolete buildings." I am quite willing to amend it by substituting the phrase "a group of buildings unsuitable for the requirements of a general hospital." We can leave the old blocks out of the argument altogether, and inquire into the justification of my criticism when applied to the newer buildings. Dr. Slater speaks of the modern hospital buildings built sixteen years ago. He describes the wards as providing accommodation for 156 adults, and as "comparing favourably with any in the country." Nevertheless he has declined my challenge to him in the local press. I suggested that one of these wards should be measured by me, and if it provided anything near 1,500 cubic feet a bed and 125 square feet of floor space, I would forfeit £5 and apologize. I knew he would decline, because these wards were built for Poor Law purposes under the Poor Law Regulations. The cubic space per bed is roughly 1,050 feet, and the floor space about 85 square feet. No one with any practical knowledge would suggest that such an allowance is adequate for general hospital purposes.

Dr. Slater also states that "within the last four years three other pavilions have been erected and put into use, each accommodating 100 patients." We are led to believe that these are part of "St. Luke's, with its splendid wards and equipment." As a matter of fact, these three "pavilions" are nothing more than some temporary emergency structures of wood and brick which were put up for soldiers during the war. A hundred soldiers could be accommodated in one of these "pavilions" by putting a row down each side and a row up the middle. Does Dr. Slater really think these are hospital wards capable of accommodating 300 patients? I leave it to your readers to decide.

In conclusion, may I say that Dr. Slater totally misunderstands my feelings in the matter? Everyone knows that Bradford requires a good first-class hospital. The Royal Infirmary Board has already gone some way towards establishing one—in fact, some building operations have actually commenced upon the new site. The proposals of the Health Committee, however, will put such a burden on the rates that the new infirmary scheme must inevitably die of inanition. I should not greatly regret it, provided the Health Committee had a good substitute to offer in its place. They have nothing of the kind. The municipal hospital cannot be made into an institution worthy of the city merely by talking about "splendid wards comparable with any in the country."

When I spoke of co-operation in my first letter I had in mind a genuine combination of effort to complete a new infirmary as soon as possible under a sound policy in which voluntary and municipal support were combined. It could be done if only the various interested parties would determine to bury all antagonism and unite to give the city what it really wants.—I am, etc.,

Bradford, Jan. 31st.

J. BASIL HALL.

RISKS AFTER OPERATIONS ON TONSILS AND ADENOIDS IN OUTDOOR CLINICS.

SIR,—I have been interested in reading the recent correspondence on this subject, especially as several leading surgeons have confirmed the opinion which I have held for some time—that these operations should not be undertaken by hospital authorities unless they are prepared to treat the children as in-patients.

With reference to Dr. Watson-Williams's remark that "We have been waiting year after year for something to turn up" with regard to further hospital accommodation for these patients, I should like to draw his attention to the manner in which these requirements are met in Leicester to-day. Two years ago I pointed out to the City of Leicester Education Committee that children suffering from enlarged tonsils and adenoids could be much more safely and effectively treated if they were kept in hospital for at least twenty-four hours after the operation than by discharging them on the same day, as was being done at that time. Since further accommodation at the hospital where these cases were being treated could not be entertained, I recommended that the education authority should establish a central school clinic, including a suitable operating theatre, and a ward containing twelve beds for the specific purpose of treating these defects. With the consent of the Ministry of Health this recommendation has now become an accomplished fact.

Previously these cases were treated at a local hospital, the arrangements being that the school surgeon should have the use of a small operating theatre three mornings each week, and that patients should be provided with beds for the day, under the supervision of a school nurse. The children were usually discharged in the evening, but in very exceptional cases a child might be kept in for the night at an additional charge. The following day, and on subsequent days if necessary, the school nurse visited the patient and noted if there was any rise in temperature or other symptoms to be reported to the surgeon. Over three thousand children have been treated in this way during the last few years. Although no serious complications have arisen, it is obvious that sending children so soon after the operation to homes that are often dirty and overcrowded, and where there is no skilled nursing, must be prejudicial to the rapid recovery of the patients.

Under our present scheme the children are kept in bed for at least twenty-four hours after the operation, and, if it is thought advisable, they can be kept longer.

From the inception of the school clinics in Leicester it has been the practice to refuse treatment entirely to any patient whose relatives could afford to pay an ordinary medical fee, whilst those who could pay a small fee have been charged in proportion to their income, and only those who were unable to pay anything have received free treatment. The following details showing the steps that must be taken to obtain treatment may be of interest:

1. The school medical officer must notify the parent that the defect exists.
2. The parent must sign a printed application form for treatment at the school clinic.
3. An investigator visits the home and records the number of persons in the family, the number of persons in work, and the addresses of their employers.
4. The amount of wages earned by each worker in the previous three months is obtained direct from the employer.
5. By means of a scale sanctioned by the Medical Service Committee, it is decided whether the case is to be refused, to be treated at a price according to income, or to receive free treatment.
6. If it is decided that the patient is to be treated, an appointment is made for a consultation with the surgeon, who determines if an operation is necessary.
7. A further appointment is made for the operation, and the parents are instructed how to treat the patient before and after the operation, by means of a printed leaflet.
8. The operation is performed, and the child remains in hospital for twenty-four hours.
9. The school nurse visits the patient the day after he has returned home.

10. Ten days later the patient is seen by the surgeon, who gives instructions with regard to breathing exercises, etc.

—I am, etc.,

Leicester, Jan. 25th.

ALLAN WARNER,
School Medical Officer.

SIR,—It is strange that in all this discussion on the risks of these operations, whether on the table or for lack of after-care, no one has suggested an alternative. There is in many cases such an alternative: I well remember demonstrating a complete cure by medicinal treatment in a case which had been taken to a consultant, "for an independent opinion" behind my back. He wrote to me to ask me to arrange for (the third) operation for removal. But with medicine they completely disappeared, and have given no sign for seven years.

In those cases which come on acutely—as, for example, after scarlet fever—or, at any rate, grow rapidly and exuberantly, it is my experience that iodine, either as tincture of iodine or as iodide, is infallible. It cures. Of the chronic cases, I find in the majority that nose breathing, with a little training as accompaniment, is generally rapidly restored by that drug. So, too, with the hearing. I have at this moment a child under observation with pronounced adenoids, and—so far—one operation, who has in a fortnight ceased to snore, and almost completely lost a deafness which has lasted the greater part of a year.

The effect is so striking that I have come to believe it wrong to subject a child to operation until it has had a fair trial of treatment with iodine in some form. If operation turns out to be necessary after all, it will be found to be much easier, more effectual and less bloody, by reason of the preliminary treatment.

For some reason I do not find enlargements of the tonsils to disappear so satisfactorily as the adenoids. But the tonsils nearly always shrink in size: they nearly always alter in texture; and, even if they have not been reduced to normal dimensions, the child loses the excessive sensitiveness to infective processes which is the worst feature of chronic tonsillitis. And, when necessary, the operation is much easier and much less bloody. The dosage is, of course, in proportion to age. I generally begin with $\text{m} \frac{1}{2}$ of tr. iodi, or gr. $\frac{1}{2}$ of sodium iodide, well diluted, thrice daily, and gradually increase the dose where necessary.—I am, etc.,

Rayleigh, Essex, Jan. 30th.

B. G. M. BASKETT.

SIR,—I write to support Mr. Fry in the views he holds with regard to the operation for the removal of tonsils and adenoids. For upwards of twenty years I operated upon these cases in the out-patient department of the Bedford County Hospital; I never sent a case into hospital on account of haemorrhage or sepsis during this period, nor has any patient developed complications. Experience is the final court of appeal.—I am, etc.,

Bedford, Jan. 30th.

S. J. ROSS.

HEMICOLECTOMY.

SIR,—In Mr. Sheen's article "On the end-results of colectomies for intestinal stasis," in the *JOURNAL* of January 22nd, p. 116, he asks, "Is there nothing besides the belt and paraffin but complete colectomy?" I would answer, "Among other things, hemicolectomy." I have done this operation (as described in the *British Journal of Surgery* for 1915) just a dozen times, and it seems to me that the risk is little, if any, more than that of the colopexy devised by Mr. Waugh, and in some cases it is a more suitable operation. All my patients recovered quickly without any complication; the only case in which there was not complete primary union was one in which cholecystostomy was done at the same time. One point in which hemicolectomy differs very much from complete colectomy is that the small bowel is not exposed in the former operation; the last few inches of the ileum are all that need be seen. There is therefore little risk of troublesome adhesions.—I am, etc.,

Bolton, Jan. 27th.

R. D. MOTHERSOLE.

GLANDULAR AND PULMONARY TUBERCULOSIS.

SIR, Dr. W. Williams, in his memorandum on the above named subject in your issue of January 29th, has touched on a matter of great interest and some importance.

Stanley Griffiths has concluded that there is some relation between attenuation of the virulence of the tubercle bacillus and the proximity of the lesion to the surface of the body, but I think that the actual suppuration of the gland has a great deal to do with the immunity of the subject against pulmonary tuberculosis. The tonsils are regarded as one of the first lines of defence against the tubercle bacillus, and are commonly the site of tuberculous lesions, but in a large series of bacteriologically verified cases of pulmonary tuberculosis I have noticed that there is practically never any enlargement of these glands. In the few cases in which some enlargement has been noticeable it has only been slight. If other tuberculosis and school medical officers have had similar experiences they would form a strong argument against the indiscriminate removal of the tonsils.—I am, etc.,

W. H. DICKINSON,
Tuberculosis Medical Officer.

Newcastle-upon-Tyne, Jan. 31st.

Universities and Colleges.

UNIVERSITY OF OXFORD.

Certificate in Practical Ophthalmology.

THE Board of the Faculty of Medicine gives notice that in and after Michaelmas term, 1921, candidates for the Final B.M. Examination will be required to submit a certificate of attendance at a course of practical instruction in ophthalmology, which included not less than twenty meetings during a period of three months, at an ophthalmic clinic recognized by the Board.

A decree was passed in Congregation on January 25th authorizing the continuance of the stipend of a woman demonstrator in the Department of Human Anatomy.

UNIVERSITY OF CAMBRIDGE.

The M.Ch. Degree.—On January 27th Mr. G. E. Wherry, on behalf of the Special Board for Medicine, brought forward a report containing proposals for raising the dignity and status of Masters of Surgery, of whom there are now only 27. He recalled the fact that until the late war this coveted degree was known by the distinctive initials "M.C.," which were then changed to "M.Ch.," in order to avoid confusion with recipients of the Military Cross. It was felt that some compensation was due to these distinguished surgeons and teachers, and the suggestion had been made that a Doctorate of Surgery should be set up. The Regius Professor of Physic, Sir Clifford Allbutt, emphasized the searching nature of the examination for the M.Ch. degree, remarking that it was exceeded in severity by the examination for no other university degree. Pending the establishment of a Doctorate, he felt that a genuine grievance might be met by revising the order of precedence in the interests of holders of the M.Ch. degree and by granting them special academic dress. At present Masters of Surgery rank in the order of presentation for degrees after Doctors in all faculties, and after Bachelors of Divinity, Masters of Arts, and Masters of Law; they wear the gown and hood of M.A.'s.

Readership in Experimental Psychology.—A Congregation held on January 28th approved the recommendation of the General Board of Studies that Dr. C. S. Myers, F.R.S., who for the past fourteen years has been University Lecturer in Experimental Psychology, should be appointed University Reader in that subject for a period of five years. With this appointment the University Readership lapses.

The following medical degrees have been conferred:

M.B., B.Ch.—P. Lazarus-Barlow, E. B. Verney,
M.B.—E. P. Hicks.

ROYAL COLLEGE OF PHYSICIANS OF LONDON.

An ordinary Comitia of the Royal College of Physicians was held on January 27th, with the President, Sir Norman Moore, in the chair.

The following were admitted to the membership of the College:

John Maurice Hardman Campbell, M.B.Oxon., James Henry Dible, M.B.Glasg., Maurice Gilbert Hannay, M.D.Brux., L.R.C.P., Bernard Hart, M.D.Lond., L.R.C.P., Frederick Greig Hobson, M.B.Oxon., L.R.C.P., Charlotte Alice King, M.D.Lond., Douglas McAlpine, M.B.Glasg., William Edward Robinson, M.D.Oxon., L.R.C.P., Matthew Sidney Thomson, M.B.Camb., L.R.C.P., William Wrangham, M.D.Lond., L.R.C.P.

Jointly with the Royal College of Surgeons, diplomas in (a) public health, (b) tropical medicine and hygiene, (c) psychological medicine, (d) ophthalmic medicine and surgery were granted to the successful candidates.

Dr. A. P. Beppard, Dr. A. J. Hall, Dr. J. W. Russell, Dr. F. Gowland Hopkins, were elected, on the nomination of the Council, councillors to take the place of Dr. Hamer, Dr. Voelcker, Sir Percival Horton-Smith-Hartley, and Dr. Caiger, who retired by rotation.

The President announced that he had appointed Dr. Herbert Spencer to deliver the Harveian Oration and Dr. Michael Grabham the Bradshaw Lecture in 1921, and that the Council has appointed Dr. Major Greenwood to deliver the Milroy Lectures in 1922.

A report dated January 4th, 1921, from Sir Humphry Rolleston

and Dr. R. O. Moon, representatives of the College at the celebration of the Centenary of the Académie de Médecine of Paris, held December 20th-22nd, 1920, was received. A medal presented to Sir Humphry Rolleston by the Académie de Médecine was offered by him to the College. The gift was accepted, and the thanks of the College voted to him.

A report from the Representative of the College on the General Medical Council concerning the session held in November, 1920, was received and entered on the minutes.

After some formal College business the President dissolved the Comitia.

Diplomas.

Diplomas in the subjects indicated were granted in conjunction with the Royal College of Surgeons of England to the following candidates:

PUBLIC HEALTH—P. F. Alderson, Madeleine S. Baker, T. B. Batchelor, W. W. Boyce, J. W. Caton, H. W. Catto, K. Comyn, T. A. Fuller, K. A. Gandhi, D. H. Geffen, E. St. G. S. Goodwin, D. N. Gore, A. J. B. Griffin, P. H. Henderson, Eileen M. Hewitt, E. T. Holden, P. G. Horsburg, T. S. Keith, N. S. Kotwall, T. A. Lawder, J. T. Macnab, A. N. McNeill, C. T. Matland, Mary Martin, J. S. Ranson, H. J. Simson, O. C. S. Tandy, A. Viney, A. S. Wakely, A. Woolcombe.

TROPICAL MEDICINE AND HYGIENE—G. V. Allen, J. Anderson, S. C. Basu, C. J. Caddick, W. B. A. K. Cullen, A. Dasgupta, A. A. Derham, A. M. El-Kirdany, R. E. Flowerdew, C. H. Hopenstall, L. C. D. Hermitte, F. V. Jacques, Z. Khaled, P. T. Liang, R. H. Liscombe, A. R. Mehta, A. S. Paranjpe, H. B. Parker, A. H. Patel, Evelyn B. Salter, R. Silcock, S. Somasundram, W. R. Taylor, A. S. Westmorland, H. G. Wiltshire.

OPHTHALMIC MEDICINE AND SURGERY—J. R. Anderson, R. S. Candlish, K. M. Labièbe, W. O. Lodge, B. H. Pesikaka, S. A. Rahim, G. Zachariah.

PSYCHOLOGICAL MEDICINE—M. Dia, E. D. T. Hayes, O. S. Martin, H. W. Paris.

ROYAL COLLEGE OF SURGEONS OF ENGLAND.

THE Hunterian Oration will be delivered in the theatre of the College by Sir Charters J. Symonds, K.B.E., C.B., on Monday, February 14th, at 4 p.m.

The Arris and Gale Lecture on the cause and prevention of myopia will be delivered on Wednesday, February 16th, at 5 p.m., by Dr. F. W. Edridge-Green, C.B.E., F.R.C.S.

A Hunterian Lecture on a research into the pathology and etiology of loose bodies composed of cartilage or of cartilage and bone occurring in joints will be delivered on Friday, February 11th, at 5 p.m., by Mr. A. G. Timbrell Fisher, M.C., M.B., F.R.C.S.

Two Hunterian Lectures on the surgery of the peripheral nerve injuries of warfare will be delivered by Mr. Harry Platt, M.S., F.R.C.S., on Monday, February 7th, and on Wednesday, February 9th, at 5 p.m.

CONJOINT BOARD IN SCOTLAND.

THE following candidates have been approved at the examination indicated:

FINAL EXAMINATION.—Medicine and Surgery: D. J. H. Ferdinando, *Medicine and Midwifery:* Pauline Figdor, R. E. Hopton, J. B. O'Neill, *Medicine:* H. Brown, L. H. Peries, G. ap V. Jones, *Surgery:* J. Murray, *Midwifery:* J. S. A. Rogers, J. J. McDonald, *Medical Jurisprudence and Public Health:* H. A. McK. Gibson, J. H. Dobbin, C. T. Williams, Marguerite M. I. Swanson, P. J. D. Dyce, J. Readdie, R. E. O'Keefe, P. E. Malloch, Marjory J. A. Ogilvie, A. G. Thom, A. R. Lambie, T. Kelarkan, D. R. Cilliers, J. A. H. Dykes, E. J. Sykes, T. F. Kelly.

The following candidates were admitted L.R.C.P.E., L.R.C.S.E., L.R.F.P. and S.G.:

R. A. Cooper, F. J. D. Cass, G. J. D. Hammond, G. J. Murray, J. Shulman, J. H. Wilson, A. Cuthbertson, M. H. Carleton, H. G. Fitz-Maurice, A. F. Caddell, P. Parthasarathy, W. G. Carew, J. Black, A. Tirumalaia, P. M. Fernando, J. B. van Cuylenburg.

Obituary.

WILLIAM L. ROBERTSON, M.C., M.B., Ch.B., F.R.C.S. ED., Surgeon, Dundee Royal Infirmary.

WE much regret to announce that Mr. William L. Robertson, M.C., of Dundee, died on January 24th in his 39th year, from septic poisoning due to a needle prick, during the performance of an operation at the Royal Infirmary.

After graduating M.A. at St. Andrews University he proceeded to Edinburgh University, where he took the degrees of M.B., Ch.B. in 1905; he obtained the diploma of F.R.C.S. Edin. in 1907. After serving as resident surgeon at the Edinburgh Royal Infirmary, the Chalmers Hospital, and the Hospital for Sick Children, Edinburgh, he became honorary assistant surgeon at the Dundee Royal Infirmary, and subsequently clinical tutor at University College, Dundee. Mr. Robertson, who was a captain in the 3rd Highland Field Ambulance, went to France with that unit in 1914, and later received a staff appointment in the 51st Division. He was twice mentioned in dispatches, and was awarded the Military Cross. On being transferred to the Italian front he was appointed to No. 24 Clearing Station, and later given command of No. 70 Field Ambulance; he terminated his work on that section

as A.D.M.S. At the conclusion of the war he was appointed a surgeon at the Orthopaedic Hospital at Bangour, and on returning to practice at Dundee was appointed full surgeon to the Infirmary and to the orthopaedic annexe. In December last he was appointed lecturer in clinical surgery at St. Andrews University, and succeeded Mr. D. M. Greig as surgeon to the Victoria Hospital.

Mr. Robertson's death, after only three days' illness, came as a great shock to his many friends and to the profession in the East of Scotland. He was a man of outstanding ability, absolute honesty and of a most lovable disposition. Ever ready to help, he combined a convincing manner with a most modest estimate of himself. The loss sustained by the medical profession in Dundee cannot at present be realized.

The Services.

HONOURS.

FOREIGN DECORATIONS.

THE King of the Belgians has conferred the Croix Civique, 1st Class, upon the following medical officers for distinguished services rendered during the course of the campaign: Major (temporary Lieut.-Colonel) Philip J. Maret, R.A.M.C., Captain Robert Wilkie Smith, R.A.M.C.(T.F.), and Captain Frederick Septimus Walker, R.A.M.C.(T.F.).

The name of Captain J. A. O'Driscoll, R.A.M.C., has been brought to the notice of the Secretary of State for War for valuable and distinguished services rendered with the British Military Mission in Siberia.

DEATHS IN THE SERVICES.

COLONEL OCTAVIUS TODD, C.B.E., A.M.S. (retired), died at Southsea on October 18th, 1920, aged 68. He was born in India, educated at Aberdeen, where he graduated M.B. and C.M. in 1878, and entered the army as surgeon on March 6th, 1880, attaining the rank of lieutenant-colonel after twenty years' service, and that of colonel on April 4th, 1906; he retired on July 1st, 1909. He served in the South African war, 1900-1902, and held the temporary rank of colonel while serving as P.M.O. of a division of the field force from May 2nd, 1900. He took part in the relief of Ladysmith, the actions at Vaal Krantz, Tugela Heights, and Pieter's Hill; operations in Natal, including action at Laing's Nek; and operations in the Transvaal; was four times mentioned in dispatches, in Sir Redvers Buller's dispatches of June 19th and November 9th, 1900, and in the *London Gazette* of February 8th, 1901, and July 29th, 1902; and received the Queen's medal with five clasps and the King's medal with two clasps. During the recent war of 1914-18 he was re-employed in England, and received the C.B.E. on June 3rd, 1919.

Medical News.

THE first meeting of the newly formed Brooklyn Cardiological Society was held recently under the chairmanship of the president, Dr. William J. Cruikshank. Among the honorary members are Dr. Thomas Lewis, F.R.S., London, Sir James Mackenzie, F.R.S., Aberdeen, and Dr. W. T. Ritchie, Edinburgh.

A SPECIAL course of lectures on fevers, their clinical and epidemic features, and measures for their prevention and treatment, will be given at Charing Cross Hospital Medical School by Dr. William Hunter, C.B., on Thursdays, February 10th, 17th, and 24th and March 3rd and 10th at 4.30 p.m. The lectures are free to medical practitioners and students of medicine.

DR. F. E. WYNNE, M.O.H. for Wigan, has been appointed M.O.H. for Sheffield, in succession to Dr. Scurfield. He has devoted himself to public health work, and during the war was Divisional Sanitary Officer of the Egyptian Expeditionary Force. For a number of years he was honorary secretary and representative of the Leigh Division of the British Medical Association, and was intimately connected with the fine and successful fight the local profession put up for recognition in the matter of the staffing and working of the local hospital.

THE anniversary dinner of the Medical Society of London will be held at the Wharfedale Rooms, Hotel Great Central, on Tuesday, March 8th, at 7.30 o'clock.

A LECTURE on "The innervation of striped muscle fibres and Langley's receptive substance" will be given at the rooms of the Royal Society of Medicine (1, Wimpole Street, W.1) by Professor J. Boeke, of Utrecht, at 5 p.m. on Wednesday, February 16th, with Professor Bayliss in the chair. Four other Dutch lecturers will also give one lecture each in English; particulars will be announced later. Admission free, without ticket.

WE are asked to draw the attention of all medical practitioners and of hospital authorities to a woman calling herself Margaret Crawford, M.B., Ch.B. Leeds (or Margaret de Lancy Williams), whose arrest is sought on a warrant by the Metropolitan police for alleged offences against the Medical Acts, 1858. It is possible that this woman will seek admission to some hospital or infirmary for the purpose of obtaining instruction in midwifery; and it is requested that any information concerning her should be communicated at once to the local police.

THE Hunterian Society annual oration will be delivered by Dr. H. H. Bashford, on "The ideal element in medicine," on Wednesday, February 16th, at 9 p.m., at the Sion College, Lambankment, E.C. All members of the medical profession are invited to attend.

SIR NAPIER BURNETT, K.B.E., M.D., has been appointed a Knight of Grace in the Order of St. John of Jerusalem.

A SPECIAL course in ophthalmology, for graduates and advanced students, is being arranged to be carried on daily during May and June at the Hôtel-Dieu Hospital, Paris, under the direction of Professor P. de Lapersonne, assisted by a staff of specialists in different branches. The course will include clinical examinations, practical (operative) work, and laboratory work, and a special certificate will be issued by the Faculty of Medicine at the end of the course. The number taking the course will be limited to forty, the fee is 150 francs (approximately £3 at present), and intending members should write as soon as possible to the Secretary of the Faculty of Medicine, Paris.

A GENERAL meeting of the Medical Officers of Schools Association will be held at 11, Chandos Street, Cavendish Square, W.1, on Tuesday, February 15th, at 4.45 p.m., when a paper will be read by Dr. E. H. T. Nash on "School punishments."

DR. WILLIAM BENTLEY PURCHASE, M.C., has been appointed deputy coroner for the Eastern District of London.

THE second annual 19th Casualty Clearing Station dinner will be held on February 19th at the Refectory Restaurant, Golders Green, London, N.W. Those wishing to be present are asked to communicate with the Rev. E. C. Doddrell, 6, Alexandra House, Regent's Park Road, Finchley, N.3. The price of tickets is 15s.

THE second International Congress of Eugenics will be held in New York City from September 22nd to 28th. The Honorary President is Dr. Alexander Graham Bell, and the President Mr. H. P. Osborn. The Secretary-General is Dr. C. C. Little, American Museum of Natural History, New York City.

As a result of the Peace Commemoration Appeal, St. Bartholomew's Hospital has received upwards of £132,000. The Governors have passed a resolution of thanks to Mr. A. F. Shepherd, who originated and organized the appeal.

A MEETING of members of the medical profession to discuss the advance of medical education in China will be held on Monday, February 21st, at 5.30 p.m., in the Barnes Hall, Royal Society of Medicine, 1, Wimpole Street, W.1. Among those who will be present are the Right Hon. Sir Clifford Allbutt, Sir Donald MacAlister, Sir Alfred Pearce Gould, and Sir Francis Champneys.

At the meeting of the Royal Anthropological Institute, at 50, Great Russell Street, W.C.1, on Tuesday, February 8th, at 8.15 p.m., a lecture (with lantern illustrations) on tailed men will be given by Professor Arthur Keith, F.R.S.

DR. C. CHAPMAN GIBBS, on his appointment as consulting physician to the National Hospital for Diseases of the Heart, after twenty-three years' service as physician, has been presented by his colleagues on the staff with a silver salver, in token of their appreciation of his work. The out-patients also presented him with a silver salver.

THE municipality of Bucharest has changed the name of one of its streets in honour of Dr. J. Clujet, the French physician, who for several years took an active part in combating epidemic disease in Rumania.

PROFESSOR LUIGI CONCETTI, editor of the *Rivista di Clinica Pediatrica*, and a well known authority on children's diseases, has recently died. His successor in the chair of children's diseases in the University of Rome is Dr. T. Lozzatti.

THE *American Journal of Obstetrics and Diseases of Children*, which discontinued publication in February, 1920, has been succeeded by the *American Journal of Obstetrics and Gynaecology*, the first number of which appeared in November.

Letters, Notes, and Answers.

As, owing to printing difficulties, the JOURNAL must be sent to press earlier than hitherto, it is essential that communications intended for the current issue should be received by the first post on Tuesday, and lengthy documents on Monday.

ORIGINAL ARTICLES and LETTERS forwarded for publication are understood to be offered to the BRITISH MEDICAL JOURNAL alone unless the contrary be stated.

CORRESPONDENTS who wish notice to be taken of their communications should authenticate them with their names—of course not necessarily for publication.

AUTHORS desiring reprints of their articles published in the BRITISH MEDICAL JOURNAL are requested to communicate with the Office, 429, Strand, W.C.2, on receipt of proof.

In order to avoid delay, it is particularly requested that ALL letters on the editorial business of the JOURNAL be addressed to the Editor at the Office of the JOURNAL.

THE postal address of the BRITISH MEDICAL ASSOCIATION and BRITISH MEDICAL JOURNAL is 429, Strand, London, W.C.2. The telegraphic addresses are:

1. EDITOR of the BRITISH MEDICAL JOURNAL, *Aitology, Westrand, London*; telephone, 2630, Gerrard.

2. FINANCIAL SECRETARY AND BUSINESS MANAGER (Advertisements, etc.), *Articulate, Westrand, London*; telephone, 2630, Gerrard.

3. MEDICAL SECRETARY, *Medisecra, Westrand, London*; telephone, 2630, Gerrard. The address of the Irish Office of the British Medical Association is 16, South Frederick Street, Dublin (telegrams: *Bacillus, Dublin*; telephone, 4737, Dublin), and of the Scottish Office, 6, Rutland Square, Edinburgh (telegrams: *Associate, Edinburgh*; telephone, 4361, Central).

QUERIES AND ANSWERS.

INCOME TAX.

"DOUBTFUL" and his wife have been separately assessed for the income from their respective medical posts. "Doubtful" has had the married allowance of £225 and his wife the £45 special allowance for the earned income of a married woman. Is this, he asks, correct?

*. As regards the total allowance, yes: the right of separate assessment does not carry with it a right to any additional allowance. It would, however, have been more in accordance with strict law if the total allowance of (£225 + £45 =) £270 had been divided between husband and wife in proportion to their respective total assessable incomes—and the same division should apply to the £225, taxable at 3s. in the £.

"DILATED PUPILS."

DR. ERNEST KINGSCOTE (London) writes: In reply to "C. F. R.'s" letter in your last issue, I saw a patient, a girl, aged 22, who suffered from dilated pupils with severe headache after reading with suitable glasses. There was no ascertainable cause. The untoward symptoms were relieved by electro-vibration on the centre of the forehead—three times a day for five minutes. The instrument used was a "pulsator." The application gave almost immediate relief to the headache. I can throw no light on the phenomena, except that vibration tends to relieve deep-seated congestions.

LETTERS, NOTES, ETC.

THE TRUE COLOUR OF TISSUES.

DR. HORATIO MATTHEWS (London, W.1) writes: The difficulty of estimating the true colours of tissues—for example, retina, etc.—which can only be examined by artificial light can be overcome by wearing plano lenses appropriately tinted to convert the spectral quality of the light used to daylight values on the principle of the Sheringham reflector. But the nature of the light used—that is, electrical, gas, paraffin, etc.,—should be specified in ordering the lens.

EARLY DIAGNOSIS OF PHTHISIS.

DR. T. A. G. HUDSON (Oldbury, Birmingham) writes: One of two further observations on the interesting article by Dr. Rivers on "The drooping shoulder sign of phthisis" (BRITISH MEDICAL JOURNAL, January 22nd, p. 120) may be of interest. Although Dr. Rivers mentions Krönig in reference to his particular article with regard to the relationship of the scapula to its fellow of the opposite side and to the spine, he has not mentioned the fact that what is probably the earliest sign of phthisis is a diminution in the area of resonance of the isthmus of Krönig, commonly at the right apex. The area of normal resonance is equal on both sides and extends from 2½ to 3 in., and any inequality in this area would point to that apex being affected even before any other signs manifest themselves. To elicit this information it is best to percuss from behind the patient, and to use a flesh pencil so as to compare accurately both sides.

HYPERIDROSIS.

DR. WILTON H. ROBINSON (Pittsburgh, U.S.A.) writes in answer to the request from "Beaten" (November 27th, 1920) for a remedy for hyperidrosis: There is a remedy that I first saw mentioned in one of the English journals some years ago

that has never failed in the cases in which I have used it. It was given at that time for bromidrosis, but seems to be equally effective in the first condition. It consists of equal parts of lead plaster and linseed oil. It is applied as a plaster under a bandage, and allowed to remain on about forty-eight hours.

PROPERTY IN A DEAD BODY.

EVERY now and then somebody is surprised to discover that a testator cannot dispose of his own body; he cannot, for instance, leave it for dissection. The bequest is void, as there is no property in a dead body. The executors have a right to the possession of the body, and their duty is to bury it. Nevertheless, the Anatomy Act, 1832, does something towards enabling a man's wishes to be carried out. If a person either in writing during his life or in the presence of two witnesses during the illness from which he dies, desires that his body shall be anatomically examined, the person having lawful possession of the body must cause the examination to be made, unless the husband or wife or nearest known relative requires interment without such examination. After such examination the body must be interred, and although interment must generally take place within six weeks of the time when the body was received for examination, this period may be extended by the Home Secretary. One legal writer suggests that the popular prejudice against dissection may be due to the fact that it has been associated by statute with felony and murder. In 1540 permission was given to the masters or governors of the mystery and commonalty of Barbers and Surgeons of London "to take, annually, four persons put to death for felony, for anatomies, and to make incision of the same dead bodies, or otherwise to order the same, after their discretions, at their pleasure for their further insight and better knowledge, instruction, insight, learning and experience in the science or faculty of surgery." In 1565 Queen Elizabeth granted to the College of Physicians the bodies of four felons executed in Middlesex "that the president, or other persons appointed by the College, might, observing all decent respect for human flesh, dissect the same." In 1663, the number of bodies so granted was increased to six by Charles II. In 1752 it was enacted that the bodies of murderers executed in London or Middlesex should be immediately sent to the hall of the Surgeons' Company, to be dissected and anatomized, and the attempt to rescue any such body was made a felony.

THE ANTIQUITY OF SYPHILIS.

ETIENNE (*La Chronique Méd.*, November 1st, 1920) supports by quotations from Suetonius the contention that syphilis occurred in Europe before the Christian era. The author has convinced himself that Augustus Octavianus Caesar (first Roman Emperor, born 63 B.C.) suffered from hereditary syphilis. The evidence advanced will scarcely appear convincing to the unbiased critic; it consists in the early death of the father of Augustus Caesar, in the record that his mother suffered from a cutaneous lesion of serpentine form, and in the statement that Augustus himself, who had small, unequal, widely separated teeth, pigmentation of the skin, cutaneous eruptive lesions, weakness of the left hip, thigh, and leg, and paresis of the right index finger, suffered periodically from attacks of pulmonary congestion, followed by psychic disturbances. Augustus Caesar, it may be remarked, died at the age of 77 or thereabouts.

VACANCIES.

NOTIFICATIONS of offices vacant in universities, medical colleges, and of vacant resident and other appointments at hospitals, will be found at pages 32, 33, 36, 37, and 38 of our advertisement columns, and advertisements as to partnerships, assistantships, and locum tenencies at pages 34 and 35.

THE following appointments of certifying factory surgeons are vacant: Ilorbury (York, West Riding), Penmaenmawr (Carnarvon), Portree (Inverness).

THE Dunlop 1921 Calendar, cleverly produced in oil facsimile by Raphael Tuck and Sons, Ltd., in conjunction with the Dunlop Company's Advertising Department, depicts a night scene in Piccadilly Circus. We understand that the accompanying date pad has been printed in almost every civilized language.

SCALE OF CHARGES FOR ADVERTISEMENTS IN THE BRITISH MEDICAL JOURNAL.

	£	s.	d.
Six lines and under	0 9 0
Each additional line...	0 1 6
Whole single column (three columns to page)...	7 10 0
Half single column	3 15 0
Half page	10 0 0
Whole page	20 0 0

An average line contains six words.

All remittances by Post Office Orders must be made payable to the British Medical Association at the General Post Office, London. No responsibility will be accepted for any such remittance not so safeguarded.

Advertisements should be delivered, addressed to the Manager, 429, Strand, London, not later than the first post on Tuesday morning preceding publication, and, if not paid for at the time, should be accompanied by a reference.

NOTE—It is against the rules of the Post Office to receive post-restante letters addressed either in initials or numbers.

A Clinical Lecture ON MUSCLE-TONUS, TONIC RIGIDITY, AND TONIC FITS.

BY
SIR PURVES STEWART, K.C.M.G., C.B.,
PHYSICIAN TO THE WESTMINSTER HOSPITAL.

Our voluntary muscles, even at rest, are in a tonus, a sort of braced-up condition. This is a reflex affair—that is, it is dependent on the integrity of the spinal reflex arc. The reflex arc, as we all know, consists of an afferent limb, (1) the sensory nerve, leading up to the spinal root, then (2) a short intermediate neurone in the grey matter of the spinal cord, and, lastly, (3) the efferent limb, consisting of the anterior horn cell, the anterior root, and the motor nerve.

Diminished Muscle-Tonus: Hypotonia.

A lesion interrupting any part of this spinal reflex arc will cause, among other phenomena, loss of muscle-tonus. If the lesion be in the sensory or afferent limb—for example, in the posterior spinal root—it is often associated with sensory loss in the corresponding root-area; if it is the efferent or motor limb which is interrupted, it is associated with muscular weakness and atrophy. A good example of loss of muscle-tonus from lesion of the posterior roots is the muscular hypotonia of tabes, which is sometimes so extreme that the patient's limbs can be placed in all sorts of unusual postures. An illustration of loss of muscle-tonus from a lesion of the motor part of the reflex arc is seen in paralysis of any motor nerve—for example, the posterior interosseous branch of the musculo-spiral, with its characteristic flaccid drop-wrist.

Increased Muscle-Tonus: Rigidity.

The opposite condition of excessive reflex activity with increased muscle-tonus may arise from irritative conditions in the reflex arc. Sometimes the irritation is in the afferent limb of the arc, as can be easily observed in the localized rigidity of the muscles around a painful or inflamed joint or the localized abdominal rigidity of an inflamed appendix. It may also result from irritative conditions of the anterior cornual cells—for example, in poisoning by strychnine or by the toxin of tetanus, although in tetanus, as we shall see later, other factors are probably concerned.

Pyramidal and Extra-Pyramidal Tracts Influencing Muscle-Tonus.

All the movements of our voluntary muscles are executed through the anterior cornual cells of the spinal cord. These receive two different varieties of motor impulses from the brain. The first class of impulses are voluntary motor impulses, from the pre-Rolandic cortex, travelling down the brain-stem along the pyramidal tracts. The second class are involuntary non-pyramidal impulses, from subcortical motor centres (such as the corpora striata, the red nuclei, the accessory vestibular nuclei of Deiters, etc.) travelling along subcortico-spinal tracts (such as the

rubro-spinal in the lateral columns, the vestibulo spinal in the anterior columns, etc.). The accompanying diagram, by Professor Stopford, of Manchester, shows what I mean. The subcortical ganglia are again influenced or reinforced by the intracerebellar nuclei (constituting cerebello-rubro-spinal and cerebello-vestibulo spinal paths, and so on). These two sets of impulses, cortical and subcortical, pyramidal and extra-pyramidal, acting on the motor cells of the spinal cord, influence the motor activity of the anterior cornual cells, the pyramidal impulses producing voluntary movements, the non-pyramidal impulses producing automatic acts. But, in addition, they have a regulating effect upon muscle-tonus and posture which is mutually antagonistic, so that, if both sets of impulses be knocked out, the normal muscular tonus is diminished and the affected muscles become not only paralysed, but also flaccid. If, however, either the pyramidal impulses, on the one hand, or the subcortical impulses, on the other, are knocked out alone, the other partner is left unopposed, and the affected muscles become hypertonic and rigid, producing so-called spasticity.

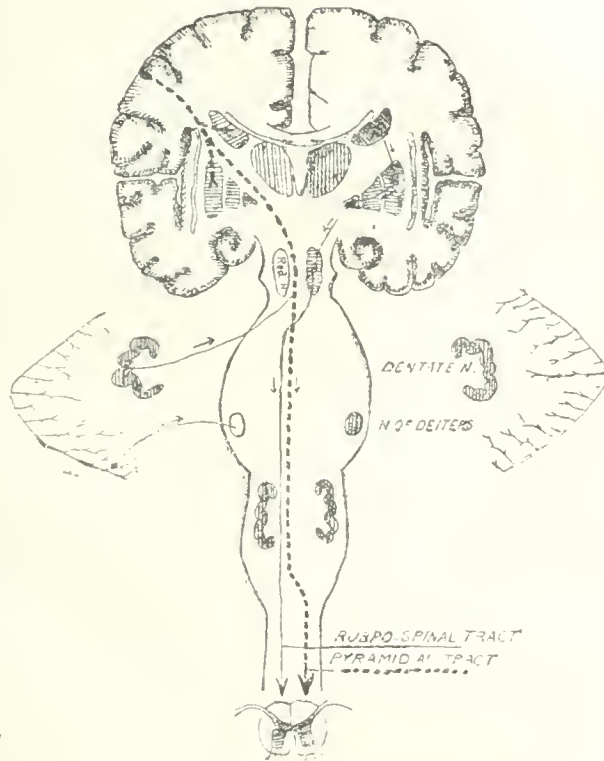

The spasticity due to pure pyramidal disease—for example, in ordinary hemiplegia—is produced by the unopposed non-pyramidal motor tracts. These act on the anterior cornual cells, and produce hypertonus in the affected muscles, which, although paralysed for voluntary movements, nevertheless can still be influenced by the subcortical centres in the corpus striatum, red nucleus, etc., so that certain automatic movements can be performed in the paralysed limb or limbs.

On the other hand, in the spasticity due to pure extra-pyramidal disease (for example, in paralysis agitans, in progressive lenticular degeneration, etc.) automatic movements, such as those of swinging the arm in walking, blinking the eyelids, certain emotional movements of the face, etc., are diminished or lost, and yet the patient, owing to integrity of his pyramidal tracts,

can still perform all ordinary voluntary movements with his spastic muscles.

When both sets of motor impulses, pyramidal and non-pyramidal, are cut off, as in a total transverse lesion of the spinal cord (say from a fracture-dislocation or from a bullet wound), the muscles below the level of the lesion at once become paralysed and we have a flaccid paraplegia—that is, one in which the paralysed muscles are devoid of muscle-tonus. This flaccid stage lasts from one to three weeks. If, however, the spinal cord lesion is incomplete, so that some fibres, whether pyramidal or non-pyramidal, still reach down to the anterior cornual cells below the level of the lesion, we then find that muscle tonus is preserved and increased from the start—that is, that the paraplegia is spastic in type. The transient loss of deep reflexes in a total transverse lesion compared with their exaggeration from the very start in an incomplete transverse lesion, is another point of interest, but we shall not discuss it on this particular occasion.

Decerebrate Rigidity.

Let us now consider what happens with a still higher transverse lesion of the brain stem, away above the spinal cord and medulla altogether, at a level which cuts off the cerebral hemispheres, together with their voluntary motor impulses, but leaves intact the great subcortical mechanisms of the red nuclei and vestibular nuclei, also leaving these ganglia free to be influenced by the undamaged cerebellum. When this is done experimentally

in animals, by transection through the brain-stem in the mesencephalon, the result is to produce so-called "decerebrate rigidity" in which the animal's limbs, both upper and lower, are rigidly extended, whilst the neck and whole spinal column, right down to the tail, are tonically hyperextended with retraction of the head. We note particularly that this lesion is a purely destructive or "negative" lesion.

In rare cases in human patients we may observe a fairly complete reproduction of acute decerebrate rigidity from unopposed activity of the subcortical motor centres. The following is an example:

In November, 1903, F. G., a man of 40, with albuminuria and arterio-sclerosis, had an attack of sudden right-sided hemiplegia of the face, arm and leg, with flaccidity of the paralysed limbs and unconsciousness. After an hour he recovered consciousness and was able to recognize his surroundings and to answer "Yes" and "No" to questions.

Three hours later he again suddenly became comatose with an entirely different group of symptoms. On top of the pre-existing flaccid right hemiplegia there appeared strong bilateral tonic spasm of the trunk, arms, and legs. The upper limbs were rigidly adducted at the shoulders, extended at the elbows, and hyperpronated at the forearms, so that the backs of the hands faced each other. The thumbs were turned inwards within the loosely flexed fingers. The lower limbs were rigidly extended at hips, knees and ankles, whilst there were occasional sharp sudden symmetrical dorsiflexion movements of both ankles. The spinal muscles were also rigid. The fingers and toes were flaccid. The upper limbs occasionally became flaccid for a few minutes, but the lower limbs remained rigid to the end. The pupils were small and inactive to light. The breathing was stertorous, with flapping of the right cheek. The knee-jerks were exaggerated and there was bilateral ankle clonus. The plantar reflexes could not be elicited owing to the frequent tonic spasms of the ankles.

The rigidity of the lower limbs and trunk persisted until death, which occurred four and a half hours from the onset of the original hemiplegic attack. The temperature ran up to 102° at the end. The pupils became widely dilated, the left being larger than the right; both were oval in outline, the left with its long axis horizontal, the right with long axis almost vertical. The pulse was 186 at the end.

At the autopsy the left lateral ventricle was distended with a large blood clot, and the left corpus striatum was ploughed up by haemorrhage. The other ventricles of the brain were normal.

Decerebrate rigidity in man is the result of a destructive lesion, usually a haemorrhage, in the mid-brain. This haemorrhage often spreads at the same time into the cerebral ventricles. It has been suggested that it is the intraventricular site of the haemorrhage which is the cause of the decerebrate rigidity, but I have repeatedly observed cases of extensive intraventricular haemorrhage in which there has been no rigidity whatever. It therefore seems to me probable that some other factor, such as oedema of the brain-stem, must be the decisive one in cutting off the cerebral pyramidal impulses and leaving the subcortical centres uncontrolled.

Acute decerebrate rigidity is usually a terminal phenomenon in a dying patient; but not always, as the following example will show:

Only last week I saw an old gentleman of 85 who had had two attacks of left-sided hemiplegia—the first at the age of 73, the second at 83—apparently due to cerebral thrombosis. Two months ago he had a couple of attacks of sudden unconsciousness and stertor, with half an hour's interval between them. In both of these he showed typical decerebrate rigidity, with tonic extension of the lower limbs at all joints, the upper limbs being tonically extended at the elbows and wrists, the metacarpo-phalangeal joints rigidly semi-flexed and the interphalangeal joints rigidly extended. The coma lasted forty minutes in the first attack and twenty minutes in the second. The pulse ran up to 120 during each attack. Throughout the attack he made champing movements of the jaws. For a few minutes after recovering consciousness he was mentally confused, but soon became bright and alert again, with no evidence of aggravation of his previous slight hemiplegia. He then went two months without further attacks, and again had another couple, of similar character but milder in degree. From these again he has made an excellent recovery.

Incomplete Decerebrate Rigidity.

Short of complete decerebrate rigidity, we sometimes meet with phenomena of chronic incomplete decerebrate rigidity—for example, in cases of cerebral diplegia, and, to a less extent, in ordinary hemiplegia.

In a decerebrate animal with tonically extended limbs, if we turn its head passively to one side or to the other, there occurs, after a short interval, a curious exaggeration of extension in the upper limb towards which the animal's face is turned (so called facial limb), together with a

diminution of the extension of the upper limb towards which its occiput is turned (occipital limb). Similarly, in certain cases of cerebral diplegia in which the subcortical centres are released from control, we can elicit so-called "conjugate automatic movements," so that, if the patient's head be turned, say, to the right, we observe that the left upper limb slowly becomes tonically flexed, whilst the right becomes extended. This phenomenon takes about a minute to reach its maximum. If we now turn the head passively to the opposite side, the attitude of the upper limbs becomes reversed.

Rigidity in Pyramidal Lesions.

Similar phenomena of decerebrate rigidity can sometimes be demonstrated in chronic hemiplegia, being limited, of course, to the hemiplegic limbs. Thus we may observe involuntary flexion of the hemiplegic upper limb when the face is turned away from the hemiplegic side, and involuntary extension of the hemiplegic limb when the face is turned towards the hemiplegic side.

Many healthy people make automatic extension movements of the upper limbs during the act of yawning (which of course is a subcortical phenomenon). By the ancients such movements were termed "pandiculation." These movements often remain well marked in the paralysed limbs in a case of severe chronic hemiplegia when the patient yawns or is tickled. The transient tonic extension which then occurs in the previously flexed rigid fingers, or the elevation of the paralysed arm, may delude the patient with the vain hope that he is beginning to recover voluntary power. But, unfortunately, these movements are not a hopeful sign. On the contrary, being due to uncontrolled activity of the subcortico-spinal motor tracts, the more profound the lesion of the pyramidal tract has been, the more marked is the pandiculation likely to be.

The well-known muscular rigidity with which we are all familiar as forming part of the classical syndrome of a pyramidal or upper motor neurone lesion, is easily recognised as due to uncontrolled activity of the subcortico-spinal motor tracts. In such a lesion the posture of the spastic upper limb in cerebral hemiplegia or monoplegia tends to be one of flexion of the elbow with pronation of the forearm and flexion of the wrist and fingers. The posture of the spastic lower limb is usually one of extension of the hip and knee, with plantar flexion and inversion of the ankle and slight dorsiflexion of the toes. These postures of the limbs occur in pure pyramidal lesions—for example, in ordinary hemiplegia of cerebral origin or in pure lateral sclerosis of the spinal cord with the "extended" type of paraplegia.

Rigidity in Extra-Pyramidal Lesions.

Muscular rigidity also occurs in pure extra-pyramidal disease from unopposed action of the pyramidal tracts. This is typically seen in paralysis agitans, in which rigidity of the face, trunk and limbs (generally beginning unilaterally) invariably accompanies the tremor and usually precedes it. In fact, severe rigidity may be present for months before tremor supervenes, or tremor may even remain absent, when we have the so-called "paralysis agitans sine agitatione."

On the other hand, if the pyramidal and the extra-pyramidal tracts are both affected together, as for example in a diffuse spinal cord lesion, we no longer find the decerebrate extended posture of the lower limbs; on the contrary, owing to loss of tonus in the paralysed extensor muscles, there is flexion of the hip and knee with dorsiflexion of the ankle, so that the limb as a whole is drawn up or shortened—the so-called flexed type of paraplegia.

Cerebellum and Muscle-Tonus.

Let us now turn to the cerebellum and its influence upon muscle-tonus. The fundamental function of the cerebellum is that of muscular synergia or co-ordination. For the efficient performance of co-ordinated muscular acts a certain degree of muscle-tonus is necessary. The cerebellar cortex is mainly a receiving platform for afferent, cerebello-petal impulses, for example, those of equilibration from the semicircular canals, also the proprioceptive impulses from muscles and joints, impulses which normally do not rise to consciousness, although when they are disordered acute discomfort is at once felt. The motor

centres of the cerebellum are located mainly in the intra-cerebellar nuclei, including the dentate, roof, and emboliform nuclei. These nuclei exercise their influence upon the anterior cornua and the voluntary muscles, not directly, since there are no direct, efferent, cerebello-spinal paths leading down to the spinal cord. The action of the cerebellum on the brain-stem is an indirect one, thrown in, as it were, from a projecting branch. It is exercised mainly upon the red nuclei and upon the accessory vestibular nuclei of Deiters, from which, as we have seen (see figure), descending rubro-spinal and vestibulo-spinal tracts lead down into the main stem of the spinal cord to influence the activity of the anterior cornual cells. Each half of the cerebellum is connected with the contralateral red nucleus and with the ipsilateral nucleus of Deiters—that is, with the ipsilateral side of the spinal cord, since the rubro-spinal tract decussates before reaching the spinal cord, whilst the vestibulo-spinal tract runs down uncrossed in the ipsilateral side of the cord.

Destructive or Negative Cerebellar Lesions.

If the cerebellum be experimentally destroyed the tonus of the voluntary muscles is at once diminished. In unilateral cerebellar lesions this loss of tonus is confined to the ipsilateral limbs and trunk. The affection of the trunk muscles in unilateral lesions of the cerebellum is dramatically shown by the fact that the tonic action of the contralateral muscles being now unopposed, the animal rotates around its own long axis in a screw-like fashion. In a case of destruction of the right half of the cerebellum this rotation is in the direction of screwing in a screw: in left-sided lesions the direction is reversed (the animal's head representing the head of the screw).

Destruction of the anterior part of the middle lobe, or vermis, of the cerebellum affects the tonus of spinal muscles on both sides, so that in destruction of the front part of the vermis the animal falls forwards, whilst if the posterior part of the vermis be removed the animal falls backwards.

In human patients sudden destructive or negative lesions of the cerebellum are comparatively uncommon, but typical examples are occasionally met with in war. In unilateral wounds of the cerebellum the ataxia of the limbs is on the same side as the lesion. It is accompanied by hypotonia of the muscles on the affected side, so that the limb "flops about" and can be placed passively in abnormal postures. This hypotonia, however, tends to pass off after a week or two. In bilateral wounds of the cerebellum not only the limbs but the spinal and neck muscles become specially hypotonic, so that the patient cannot stand or even sit up unless he is supported. After a short time, if the lesion be stationary, compensation occurs, and the hypotonia rapidly subsides.

Irritative or Positive Cerebellar Lesions.

Lastly, we have to consider the effects of irritative or "positive" lesions of the cerebellum. These will increase muscular tonus and produce tonic rigidity of the affected parts. The mechanism through which this is effected is probably by means of intra-cerebellar nuclei, not the cerebellar cortex. Stimulation of the upper part of the dentate nucleus has been shown by Horsley and Clarke to produce deviation of the head and eyes towards the ipsilateral side. Stimulation of the basal portion of the dentate nucleus, together with the upper portion of the other adjacent intra-cerebellar nuclei on the same side, produces tonic flexion of the ipsilateral elbow, whilst stimulation of the paracerebellar nuclei alone, without the dentate nucleus, produces tonic extension of both legs, closely resembling the posture of "decerebrate rigidity."

Tonic or Cerebellar Fits.

In rare cases we may come across rigidity in man from irritative cerebellar lesions, producing a variety of "tonic fits." In these so-called cerebellar fits the posture of the lower limbs in extension is what we have already described, but that of the upper limbs is not quite the same as in ordinary decerebrate rigidity from a negative or destructive lesion of the brain-stem above the red nuclei. In irritative cerebellar lesions the typical hyperpronation of the forearms is often absent.

Let me relate to you an example of these "cerebellar fits" which some of you have witnessed in the wards.

R. N., a little boy of 4 years, was healthy until the age of 3½, when he began to have "fits." At first about two used to occur in every twenty-four hours, one during sleep and another on waking in the morning, but after a couple of months they rapidly increased in frequency, and by the time he came under observation they were occurring about every half-hour or so, day and night. Together with the increase in the fits, the child's intelligence rapidly deteriorated. Previously bright, active and lively, he became dull, apathetic, and neglectful of the sputum-cup; his speech, previously fluent, became less distinct, so that he intermingled inarticulate noises with his almost monosyllabic, most unarticulated words. He occasionally placed his right hand on the side of his head, as if in pain. There was no vomiting. A week before I first saw him he became unsteady in his gait and occasionally fell when walking.

When first examined, on May 1st, 1920, he was mentally dull, but he understood and executed verbal requests to shut his eyes, put out his tongue, etc. He named accurately objects shown to him, such as a watch, penny, and scissors, but articulated his words very indistinctly. The optic discs and fundi were normal. The pupils were equal and normal in reaction. There was a fine rotatory nystagmus, only noticeable during ophthalmoscopy. The cranial nerves were otherwise normal. There was no cutaneous anaesthesia or analgesia, and all the limbs were powerful. The gait was extremely unsteady and reeling, so that he frequently fell, but not constantly in any special direction. The knee-jerks were brisk and equal; the ankle-jerks were absent. The plantar reflexes were flexor in type, and the abdominal reflexes were absent. Kernig's sign was negative.

During examination he had one of his fits of which the following is a detailed description. The child suddenly became momentarily unconscious with cyanosis of the lips and face, dilatation of the pupils and turning of the eyes steadily to the right side, with transient flickering of the eyelids. Meanwhile all his limbs became rigid. The upper limbs became rigidly extended at the elbows and rigidly flexed at the wrists and metacarpophalangeal joints; the lower limbs were rigidly extended at the hips, knees and ankles, and inverted at the ankles. After lasting about twenty seconds the elbows became semiflexed and the fingers twitched slightly for about ten seconds, the lower limbs remaining rigidly extended as before. He then gave a deep sigh and recovered consciousness. There was no biting of the tongue nor affection of sphincters during the attack.

The patient was kept under observation in Westminster Hospital for two months, during which he had numerous daily attacks similar to the above, numbering from seven to twelve in the day and four to six at nights during sleep. At the onset of the fits the eyes were turned sometimes to the right side, sometimes to the left. After an attack the child was not stuporous but seemed wide-awake, and went on playing with his toys.

Radiograms of the skull showed no abnormality, and the optic discs remained normal. Bromide medication had no apparent effect on the frequency of the fits.

In view of the persistence of these cerebellar attacks I asked my colleague, Mr. Spencer, to do a decompressive operation. Accordingly, on July 23rd and 27th a two-stage operation was carried out, in which both cerebellar hemispheres were widely exposed, the straight sinus between them being divided and the dura freely opened. The cerebellum bulged markedly, especially its right hemisphere, but no tumour was seen or felt in any accessible part of the cerebellum. The wound was closed and healed uneventfully, but the flap remained bulging.

During the early half of August, following the operation the fits continued for a time, but with much diminished frequency. In the latter half of August only four attacks occurred, and from August 30th onwards they ceased altogether.

When re-examined on October 26th, 1920, and again on January 4th, 1921, he was bright and intelligent with normal speech and articulation. The optic discs and cranial nerves were normal. He was free from nystagmus. There was no weakness or ataxia of the limbs, and he walked and ran about like other children, but was said to be somewhat excitable and impetuous in temper. The operation flap bulged as before.

I may also remind you that many years ago Hughlings Jackson¹ regarded the phenomena of tetanic convulsions, with their tonic spasm of the face, risus sardonicus, jaws, neck, trunk and limbs, as a variety of cerebellar fit. It is probable, however, that in tetanus the mid-brain nuclei and the anterior cornual cells are also implicated in the irritative process.

Another point of interest is raised by the head retraction and spinal rigidity of basal meningitis. Whether this is also to be regarded as a variety of cerebellar irritation is well worth consideration.

Time does not permit of our attempting any adequate discussion of other incomplete varieties of tonic fits. But those of you who are interested in the matter will find many suggestive points in a recent paper by Dr. Kinnic Wilson, where the subject is discussed in greater detail.

REFLECTIONS.

DIATHERMY IN DISEASES OF THE THROAT AND NOSE.*

BY

W. J. HARRISON, M.B., M.R.C.S.,

ASSISTANT SURGEON, THROAT AND EAR HOSPITAL, NEWCASTLE-ON-TYNE.

SURGICAL DIATHERMY—sometimes called the cold cautery—consists in coagulation of the tissues by heat generated in the tissues themselves by the passage of a high frequency current of considerable strength. Up till comparatively recently, high frequency currents were not used in surgery, only minute currents of a few milliamperes being used for the destruction of small naevi, removal of superfluous hairs, etc. In diathermy, currents running up to 1 to 2 ampères are often used in throat operations.

The first operations by this method in this country were performed by Professor Nagelschmidt of Berlin in Mr. Harmer's clinic at St. Bartholemew's in 1910. He removed a large malignant growth of the soft palate, an inoperable naevus of the tongue, and enlarged tonsils. Mr. Harmer became the pioneer of this treatment in England, and since he showed his first case at the Laryngological Section of the Royal Society of Medicine (a case of inoperable cancer of the fauces) a great number of throat surgeons throughout the country have taken up this way of operating, and have recorded very satisfactory results. Although greatly interested after seeing Mr. Harmer operate on several cases, the war prevented my doing any cases till this year, and I have to thank the surgical staff of the Royal Victoria Infirmary, Newcastle-on-Tyne, for allowing me to operate on some of their cases.

In the following description of the method of using diathermy I have thought principally of operations for malignant disease of the mouth and throat; but in all essentials the method is the same for any growth. Various ends for the active electrode are used, and various methods may be used in dealing with the growth according to its size and situation (it may be removed or coagulated *in situ*), and different strengths of the current are needed; 300 to 400 milliamperes may be sufficient when an angioma has to be coagulated, and 2 ampères are required when dealing with a large malignant growth.

Prior to operations on the mouth and throat the mouth must be got into as healthy a condition as possible, and septic and decayed teeth attended to. At the time of operation the growth should be painted with iodine. A large negative electrode, thickly padded with cloths thoroughly wetted with saline, is placed on the chest, back, or thigh of the patient, and it is important to have this electrode lying evenly and in close contact at all points, otherwise burning may occur. I use three towels as the pad, and, if the operation is long, inspect the place to which they are applied, so that any signs of burning or scalding may be detected at once. The growth is dried and a small active electrode placed on it. The current is switched on and gradually increased until of sufficient strength, and it is then kept at this strength in the following applications. The result of passing a large current through this small electrode is that great heat is generated in the tissues below the electrode. They turn white and bubbles appear, and if the current is allowed to flow sparks begin to leap from the electrode. The application should not be long enough to allow these sparks to appear, and the current should always be switched off before the electrode is removed from the growth, as, if this is not done, sparks fly when it is taken off, and surrounding tissues are injured. The coagulation extends to a considerable depth, varying according to the strength of current and length of application. The whole growth is gone over in this way until it is coagulated *in situ*, and, should it be necessary to coagulate more deeply, some of the slough may be gently scraped away, and the electrode again applied. The tissues become intensely hot after one or two applications, and it is advisable to wait a short time to let them cool, or unnecessary damage may be done to surrounding parts.

As the heat coagulates the tissues it also sterilizes them, so that a large, deep, sterile slough remains. There is no bleeding during the operation, as blood vessels and lymphatics are sealed. This is a matter of considerable

importance, particularly in malignant growth, as these channels of septic absorption and dissemination of growth are left open in all cutting operations, and in cutting operations there is always a risk of implanting malignant cells in healthy tissues. Some of the slough may be gently scraped away to hasten its separation, but it should never be removed to such a depth that there is any risk of haemorrhage, nor should any except quite loose pieces be removed, as it is being thrown off during the process of healing. There is often, after the operation, a considerable outpouring of lymph and oedema in the surrounding tissues. Cases have been recorded where tracheotomy has been required, and in all operations in the neighbourhood of the larynx this should be done as a preliminary.

The temperature may be raised for the first two days, but rarely reaches 100°, and generally subsides in forty-eight hours, when in many cases the patient may get up, even after extensive operations. There is soreness in the operation area, but the pain is less than in cutting operations or where a cautery has been used, and a patient whose soft palate and fauces I operated on was eating solid food on the third day. The resulting slough looks rather alarming, and makes one think of secondary haemorrhage, septic absorption, and septic pneumonia. Secondary haemorrhage is a danger when working near large vessels, but smaller vessels are closed by coagulation. Septic absorption is less than in cutting operations, for the reasons given above, and septic pneumonia does not occur more often than when the knife is used, and many say less often. I have had no cases up to the present. As the slough separates a healthy granulating surface is left, which rapidly becomes covered with epithelium, and in many cases there is little formation of fibrous tissue, so that a soft pliable scar results.

I wish to speak mainly of the use of this method in malignant disease, so I will only mention briefly some other conditions in which it has proved valuable.

Naevi and cavernous angiomata, situated on the lip, cheek, tongue, etc., have been dealt with very satisfactorily. They can be coagulated piecemeal when large and otherwise inoperable, and when they affect the lip or cheek they can be attacked from within the mouth so that no scarring results.

Tonsils.—In a certain number of cases the contraindications to removal are so strong that, although the tonsils need to be enucleated, they are not operated on, or only with much misgiving and hesitation. Such cases can be dealt with entirely satisfactorily.

Lupus.—Nasal lupus, as we all know, is one of the most intractable conditions. Scraping, cautery, ionization, x rays, local applications of drugs are all tried, often with little effect, and one works on with these cases for months. I have lately been treating by diathermy a few cases sent me by Dr. Bolam and Dr. Thompson. It is too early to make any definite statement as to cure in these cases, but Dr. Thompson, who has been watching them, agrees with me that they have made greater improvement in a shorter time than they would have done by other methods. (Nagelschmidt said he could do more in two or three applications than he had previously done with 600 to 700 hours' exposure to Finzen rays.) All have been having x-ray treatment for some months. One patient, in whom both vestibules, the septum and the inferior turbinates were involved, has had four applications. The ulcerated surface is healed and, at present, no signs of growth can be seen. Another very similar case now shows only a small healing patch on the inside of the ala. The applications are very easy to carry out. A fortnight elapses between each treatment, which only takes a minute or two, and is practically painless, as cocaine is previously employed.

Nasal synechiae, nasopharyngeal fibromas, and rodent ulcers have also done well under this treatment.

Turning to malignant growths of the mouth, fauces, etc., it is, of course, impossible in any case to make a definite prognosis. A small growth easily removed may rapidly recur, while in another case, where operation appears almost hopeless, the patient may remain free from recurrence, or it may only reappear after a long time, during which the patient has been in good health. One can only say that a slow growth, in which there is no involvement of the glands, occurring in an elderly person, offers the best prognosis; but even in such a case one at times finds a rapid recurrence, and the recurrence is often of a more malignant nature than the primary growth.

We may divide malignant growths into (a) those which can be operated on by the knife; (b) those which cannot be operated on by the knife. Many of the former cases can be safely and easily dealt with in the ordinary way, but in others operation entails severe shock and risk, both at the time of operation and subsequently. I do not wish to say that all cases should be operated on by diathermy,

* A paper read before the North of England Branch of the British Medical Association.

but many now operated on by cutting operations would be dealt with equally well, if not better, so far as the removal of the growth is concerned, and with much greater safety and comfort to the patient, were diathermy used. It is often very difficult indeed to cut sufficiently wide of a growth involving the floor of the mouth or the posterior half of the tongue, but comparatively easy to coagulate. Growths of the fauces, soft palate or pharynx involve severe operations which can be done with much greater ease, safety, and rapidity by diathermy. Growths in the aryteno-epiglottidean region must also be included. In many cases coagulation and cutting can be combined. I removed half a tongue in this way with no haemorrhage, and more widely than if knife and scissors alone had been employed. The lingual artery was tied to minimize the risk of secondary haemorrhage, but even then, had cutting alone been employed, there would have been free bleeding.

Passing to the cases which are inoperable by cutting operations, they may be divided into: (1) Those which can be operated on by diathermy; (2) those which are inoperable. Of the former group, some are attacked with the hope that recurrence will not take place for a long time, and others to relieve symptoms. Many growths are so situated that they rapidly pass beyond the range of the knife, and many patients are not seen till this stage is reached: growths of the tongue in its posterior part, fauces and pharynx are examples. Sprays, etc., are used to keep the growth clean, morphine to ease the pain; but the patient goes downhill steadily, suffering great pain and discomfort, and death is a relief to him and his friends. There are now numbers of such cases recorded who have been operated on by diathermy and have lived in comfort for a considerable time without recurrence; when recurrences have taken place, they have been treated again and life prolonged. I have such a case to show this afternoon. He had an inoperable growth of soft palate, uvula and left fauces in April, was treated by diathermy on May 6th, 1920, and there is no sign of recurrence at present. There are other cases in which life has not been prolonged to any extent, but where symptoms have been greatly relieved, and they have died a much less painful death. One of the things which everybody who has used diathermy has noticed is the great relief from, or modification of, pain that often occurs, even in cases in which the whole growth cannot be removed. Massive ulcerating growths causing dysphagia and dyspnoea may be treated, giving the patient relief from these conditions.

Diathermy is no more a cure for malignant disease than any other treatment, but it can be used not only in cases which are operable in the ordinary way with greater safety and often with greater advantage, but also in cases which are beyond the scope of the knife. Post-ericoid growths—86 per cent. of which occur in women, and many in comparatively young women—have been dealt with, and life prolonged and much relief afforded, the pain and difficulty in swallowing being greatly relieved and in many cases temporarily cured. The operation is by no means without risk, but the condition is so desperate that the risk is justified. Cutting operations show a very high mortality, and can only be attempted in very early cases. Stuart Low has shown a number of cases in which large masses of malignant glands, which could not be removed, have been delayed in growth and diminished in size, and pain greatly modified, by plunging a diathermy point into them in many places. He dissects the cutaneous tissues off the growth first, and after the operation sutures them again, and in no cases has he had any ill effects follow.

It has been impossible owing to time to mention much of interest, and only a brief outline has been attempted; but I shall conclude by tabulating the advantages and disadvantages of diathermy.

Advantages.

Shock is practically nil, even after extensive operations. Pain after the operation is less than after operation by knife or cautery.

Temperature is only slightly if at all raised, rarely reaches 100, and drops within forty-eight hours.

The dangers of metastasis are much less than with cutting operations, blood vessels and lymphatics being sealed.

Risk of septic absorption is less than in any other form of operation.

There is complete destruction of visible and palpable malignant disease, and probably many outlying cells are destroyed

which could not otherwise be reached. Malignant cells are of lower vitality than those of healthy tissue.

The operation is practically bloodless, is rapidly and easily performed, and can be easily repeated if necessary.

Tumours that are otherwise inoperable can be attacked.

Convalescence is rapid.

In many cases which are hopeless, relief can be given to the patient.

Disadvantages.

Healthy and diseased tissues are destroyed, but in cutting operations this also takes place.

Important vessels and nerves cannot be seen.

There is danger of secondary haemorrhage when working near large blood vessels.

There is a tendency to the formation of keloid when skin surfaces are involved.

THE MATERNITY HOSPITAL, WITH ITS ANTE-NATAL AND NEO-NATAL DEPARTMENTS.

BY

J. W. BALLANTYNE, M.D., F.R.C.P.Ed.,

PHYSICIAN IN CHARGE OF THE ANTE-NATAL DEPARTMENT OF THE EDINBURGH ROYAL MATERNITY HOSPITAL, ETC.

A NEO-NATAL ward and clinic, an ante-natal clinic, and a pre-maternity ward are all needed in order to complete a modern maternity hospital in its rounded fullness. Gynaecological and pathological departments may be added to the building or may be provided elsewhere, according to the requirements or the institutional resources of the city or town in which the maternity hospital is situated; but the neo-natal and ante natal departments are essential to the entire fulfilment of its purpose.

The maternity hospital occupies a separate place among hospitals, for, whilst they are designed for the relief of the sick, it is for the reception of many to whom the words "absolutely healthy" may be fitly applied. It is a hostel rather than a hospital. When Sir Thomas Browne wrote, "For the world, I count it not an Inn, but an Hospital, and a place, not to live, but to die in," he was not thinking of the ideal maternity hospital of to-day and to-morrow, but of the very real general hospital of his time. When criticism asks ironically if living healthy mothers accompanied by living healthy babies always emerge from maternity hospitals, one has, of course, to admit sadly that they do not. With this admission, however, one is now justified in asserting that the things of which they die are preventable in the case of the mothers, and generally so in the case of their infants. The recognition of the preventability of maternal deaths in connexion with parturition has become wonderfully clear in recent years, and systematized efforts are now being made in many places and by ante-natal clinics and pre-maternity wards really to prevent such fatalities. On account of a less degree of familiarity with the causes of the diseases of the newborn infant it is not realized how possible their prevention also is; indeed, it is scarcely recognized how terribly fatal these maladies are, although the separate publication of the neo-natal death rate does not long leave this depressing conclusion in doubt. Their severity and their preventability are the incentive and the justification for the neo-natal department of the maternity hospitals of the future.

The Maternity Hospital of the Nineteenth Century.

Up to the close of the nineteenth century the maternity hospital was held to have discharged its legitimate functions when it made itself responsible for the care of women in labour, and of them and their babies in the puerperium. Within this limited sphere of service they achieved a measure of success, and their occasional but rather spectacular failures were in process of restriction towards the end of the century by the introduction of the practice of antiseptic and aseptic principles. Their too complete concentration upon the act of delivery and upon the days of recovery following it was, however, a heavy handicap to real progress in the rational understanding and in the practical solution of the problem of attaining safety in human reproduction. No amount of perfection in operative technique or in instrumental resource could cancel or annul the absence of supervision and care in the ante-natal months; one might, if one cared, speak of the brilliant performance of a craniotomy, but the executive

splendour of such an achievement was certainly not that of the sun, and it hardly attained to the lesser degree of the moon, for one felt instinctively that when there were two lives at stake there was little glory gained by saving the one at the expense of the other. Further, in too many places the maternity hospital had come to be almost wholly the refuge of the illegitimately pregnant mother carrying her unwanted baby; ethical considerations were unwarrantably dragged into purely obstetrical problems; and as a result the "unco guid" left no large benefactions for such institutions, and their annual meetings were sparsely attended in contrast with those of the palatial infirmary and the much admired sick children's hospital.

The Maternity Hospital of the Early Part of the Twentieth Century.

With the dawn of the twentieth century came the development of the idea of the hospitalization of pregnant women and the concomitant conception of the prevention of obstetric disasters thereby. The "ambulant patients" of the past were more generously recognized as the "expectant mothers" of the present day, and the kindlier breezes of the spring-time began to play around the maternity hospitals and their inmates in place of the coldness of the winter's blasts. By and by, and, as it would seem, by a special providence, maternity as an outlier or sort of Cinderella sister of child welfare came with a rush into the full sunshine of national recognition, approbation, and encouragement, and this has been accompanied by a small trickle of pecuniary support, perhaps the herald of the refreshing and much-needed shower. In the bringing about of this welcome change many forces were doubtless at work. The falling birth rate played its part: the havoc of the war was the voice of the prompter; the great principle of modern medicine—that "prevention is better than cure"—was the prevailing motif; interest in the wonders of pregnancy as a symbiosis and in embryology as the fairyland of science took its place in the *scenario*; and the uprush of public opinion on the rights of womanhood to a full fruition supplied the insistent chorus. These all were there; but the concrete fact so far as the maternity hospital was concerned was the opening of pre-maternity wards and the starting of ante-natal clinics.

The Ante-natal Department.

The development of an ante-natal department began in different ways in different places. In the Edinburgh hospital, which the writer believes to have led the van in this forward movement, the beginning was the founding of a bed for the diseases of pregnancy in 1901. The bed was soon increased to a ward with four beds, and the name "pre-maternity," which the writer had given to the former, was soon extended to the latter. Other events followed. Pregnant patients at all ages of gestation began to be cordially welcomed at the hospital and urged to return for supervision; nurses with special knowledge of pregnancy and its maladies began to go amongst the expectant mothers, and persuade them to come to the hospital for advice regarding the inconveniences as well as the danger signals of pregnancy; such "pre-natal nurses" were furnished with schedules by the writer setting forth the chief danger signals and were encouraged to fill them up; then separate hours and days were set apart for the seeing and advising of pregnant women, and these came to be called mother-consultations or ante-natal clinics. Next, the system within the hospital was conjoined with the town scheme of maternity and child welfare, the hospital itself formed the head centre of the mother-welfare part of the scheme, and health visitors began to act as an auxiliary staff outside the hospital; then the scattered activities in the hospital were gathered together in an annexe of the building and called the ante-natal department; and, lately, the care of the expectant mothers suffering from the venereal diseases has been added to the other duties of this new department. In the building up of this elaborate edifice smaller stones had to be hewn and fitted in, but the portions mentioned above were outstanding, and the pre-maternity ward was the great corner stone. In a series of some thirty articles published at various times in various places the writer has described the stages of the progress of the idea and the details.

The hospitals in the large towns in England, in contrast to Edinburgh, seem to have started their ante-natal departments with the ante-natal clinic as a foundation,

and thereon to have built up towards the pre-maternity ward; but all do not seem to have reached that culminating institution. In the case of towns without a maternity hospital the ante-natal clinic allowed a beginning to be made to which a maternity hospital could be added later; but it can never be too often insisted that the ante-natal system without a pre-maternity ward or beds is dangerously incomplete, for whilst it ensures the detection of dangerous maladies in pregnancy it gives no destined place for their treatment. For pure prevention it may suffice (and that is much), but for curative success it is insufficient. In Glasgow, as may be learnt from the recently published report by Dr. Chalmers, the medical officer of health, ante-natal dispensaries and an ante-natal ward in the Glasgow Royal Maternity Hospital were opened between 1916 and 1918. In America the "pre-natal nurses" of Boston seem to have led the way in the development of ante-natal work, which later was affiliated with maternity hospitals and medical institutions; throughout it has been pre-eminently a movement in the full gaze of the public. During the war America to a large extent carried her ideas on mother and child welfare into France.

There have been differences also in nomenclature. Ante-natal clinics have also borne the names of pregnancy clinics, *ante-partum* consultations, free consultations for expectant mothers, and the like. The pre-maternity ward has been called the ante-natal or the pregnancy ward. One may speak of an ante-natal department or of a pre-maternity system; and of course the words ante-natal and pre-natal are synonymous. The writer's predilection is for pre-maternity ward and ante-natal clinic, but he has no strong preference. In 1891 or thereabout he was looking for a word which should express and include all the scattered subjects known as teratology, fetal diseases, germinal infections, monstrosities, morbid heredity, and the like, and he decided upon ante-natal pathology; but he was not strongly set upon it, and a mere turn of the die might have led him to *pre-natal* pathology, with the advantage of a syllable less to pronounce every time. Towards pre-maternity he had a much more decided leaning, and thought it more expressive.

It is hardly necessary in these days to write of the advantages to the maternity hospital of its ante-natal department. During recent months medical journals, and especially those devoted to maternity and child welfare, have published many appreciations; they have sometimes, too, added statistics, although the profitable time for discussing results has not yet come. The present danger, perhaps, is undue optimism, for there are parts of the subject which are still unknown, and the interrelations between mother and child are subtly complex. On the other hand, a maternity hospital which has added to itself an ante-natal department will not easily let it (with its illuminating "reports in advance") go again. It would be easy to enumerate some of the most obvious advantages it gives, such as an exact knowledge beforehand of the relation of the head of the fetus to the brim of the mother's pelvis, the correction of malpresentations and the rectification of malpositions, the prevention or cure of many of the smaller annoyances of pregnancy such as the pressure effects, the fully-informed treatment of many of the really severe danger signals of gestation such as those of toxæmia, the more accurate foretelling of the date of delivery, the estimation of fetal health or disease, and particularly the opportunity it gives for systematic treatment of the venereal diseases; but here it must suffice to emphasize more generally its outstanding value. That, in a word, is *prevision*.

The ante-natal department of a maternity hospital is like the air service of an army. Only a very incompetent commander would dare to attack without scouting, without a reconnaissance, and without his aviators who carry out both. Ante-natal supervision from the early months gives a bird's-eye view of the whole field of operations, and prepares the obstetrician for the attack he has to make upon the foe, that "auld enemy" death and disease, at the time of the confinement. He may find no signs of enemy presence; so much the better for his patient and so much the easier for him. On the other hand, he may discover the carefully camouflaged battery or the deadly cross-roads, with the most immediately happy results in the adoption of an advance in another

and a safer direction. Without such foresight and foreknowledge he is blinded like the general whose aeroplanes cannot rise or have been sent down crashing by the enemy. In both cases fog is a trouble. In obstetrics it often takes the form of hydrannios or of some other abnormal intrauterine condition which hides the underlying facts. Further, the two services are alike in the risk which they run when communication is interfered with; when by reason of a fault in the "wireless" the aviators are not getting their messages through there is danger; so when, through a lack of hearty co-operation between the ante-natal department and the delivery part of the maternity hospital, the labour ward is not getting its reports, there is grave risk. The ante-natal clinicians are the air force of obstetrics, and indispensable.

The Maternity Hospital of the Near Future.

It may be safely predicted that when the maternity hospital has its ante-natal department in thorough working order—that is to say, when patients begin to come at early dates in their expectancy and when all that can be discovered about them is learnt with accuracy at each visit—there will follow an immense gain to the practice of the institution in certainty of diagnosis, in early provision of danger and consequent rational choice of treatment, and in lessening of maternal, of fetal, and of infantile mortality and morbidity. Only one disadvantage has the writer heard—the ante-natal department may spoil the *operative* work of the place! It may, of course, replace a craniotomy by a Caesarean section now and again, not altogether a disadvantage, one thinks; it may actually diminish the number of operative interferences, not without bringing some sort of relief to the expectant mothers.

Even the best of ante-natal departments, however, do not entirely solve the maternity hospital's difficulties. The infants have to be cared for after birth as well as before it. To some extent—nay, to a large extent—ante-natal care, by lessening the risks of premature labours and in other ways, makes it more likely that babies will be born alive and will go on living; but it is insufficient in itself to do all that is needed by the delicate infants, by those who are diseased or deformed, and by those who add prematurity to the other impediments in their way to life and health. For them there must be something more; that something more may be called the neo-natal department.

The Neo-natal Department.

It is quite unnecessary to argue on behalf of the need for some means other than what is now in our possession for the care of the neonate during the month which follows birth. It is sufficient to state again the well known fact that more lives are lost in the first month of the life after birth than in any other. The neo-natal death rate, which is for one month, is about 40 per 1,000 *live* births, whilst the infantile death rate, which is for twelve months, is about 100 per 1,000 *live* births. If the stillbirths are added to the neo-natal death rate, as they may very properly be, the result may be as much as 80 per 1,000 births. The present neo-natal death rate is a powerful and a sufficient argument for the provision of a neo-natal department, or at any rate of greater neo-natal supervision and care. What is needed is realization that many of the neo-natal deaths are preventable, along with the concentration of medical and especially of obstetric attention upon them.

The causes of the high neo-natal rate are not difficult to find. Some neo-natal disasters are, so to say, postponed deaths. But for the favourable circumstances of ante-natal life the unborn infant would have died before its expulsion from the womb, for it had the potentialities of death in it. Instances of this are found in grave malformations and marked tissue changes due to disease. Other disasters are due to an actual absence of knowledge regarding the causation of many of the peculiarly neo-natal maladies, regarding their diagnosis, and regarding an effective treatment of them. Instances are supplied by nearly all the diseases (such as icterus, haemoglobinuria, melaena, sclerema, and oedema) which appear with the word *neonatorum* after them. Yet others are due to the prematurity of the infant, and another group contains cases in which the fatal issue is the result of the traumatism of birth or of infections received during it. But there is yet another maleficent influence at work: neo-natal life lies, so to say, on the "divide" between two great departments of medi-

cine, between obstetrics on the one hand and pediatrics on the other, and it runs the risk of receiving insufficient attention from both. It is situated where obstetrics and pediatrics meet; and, so far as hospitals are concerned, its home is the interspace between the maternity and the sick children's hospital. In general practice the medical practitioner and the midwife are supposed to be in charge of the neonate as well as of his mother for a month; but it has to be admitted that too often the vigilance of both attendants flags long before the dangerous four weeks are over. It is to the honour of the doctor and the monthly nurse that brilliant triumphs have been recorded in the saving of weakly premature infants; but they are none of them achieved easily and they are sadly too few. A scrutiny of the complete returns of any maternity hospital (including the follow up statistics of the babies who leave the institution about the twelfth or thirteenth day of life) will convince any who may be sceptical about the number of deaths which may be easily prevented at this age.

An attack upon the neo-natal mortality may, of course, be made by other means than the establishment of a neo-natal department in maternity hospitals. It may be made by handing the infants over to a sick children's hospital the moment they are born; but there are obvious disadvantages in this way of dealing with them, including their removal to a distance from their mothers and away from the attendants who have knowledge of the characters of the labour and the records of the ante-natal conditions. It may be done by the erection of special hospitals which may be named infants' hospitals or babies' institutes or "prematilities," and which would be under the care of doctors and nurses who would be, so to say, specialists in the management of delicate neonates; in these institutes also there might be well equipped laboratories for the investigation of the various problems of the causes of neo-natal deaths and for the preparation of the necessarily modified food. The great objection to such institutions is that it is unwise to increase the number of hospitals, especially in these days of financial strain, if their function can be performed by additions to existing hospitals. A neo-natal department in a maternity hospital may in the meantime meet the want.

The neo-natal, like the ante-natal, department must be a part of the maternity hospital; preferably it ought to be an annexe. It should consist of two parts—a pathological and a clinical. The former, which might be called the neo-natal pathological laboratory, should be devoted to research into the causes of early neo-natal deaths and of stillbirths, and would be under the care of an expert in ante-natal and neo-natal pathology. Already some hospitals have such a laboratory. In Edinburgh and Glasgow, for instance, for more than a year now the stillbirths and early neo-natal deaths have all been examined in searching necroscopies by Dr. F. J. Browne and Dr. A. M. Kennedy respectively, the latter working in a portion of the hospital, and the former in the neighbouring *post mortem* department of the Edinburgh Royal Infirmary. The publication of these researches which are being carried out under the Medical Research Council's Child Life Investigation Committee—ought to do much to advance the knowledge of neo-natal pathology. The clinical part of the neo-natal department should consist of a ward (or wards), not far removed but distinct from the ordinary puerperal patients' ward. The neo-natal ward will be furnished with electrical incubators and all other life-preserving means, will be under the management of physicians and sisters skilled in the treatment and nursing of newborn infants, and especially of premature and weakly ones, and will be most carefully guarded against infection. In some respects—for instance, in its temperature—its hygiene will be peculiar to itself, for it is really intended to serve as the real nursery, almost as the hothouse of the hospital. It must never be forgotten that a prematurely born infant is really a fetus struggling against the rigours of an environment for which he is not yet prepared; he is truly the tender exotic plant requiring the moist warmth of the conservatory until such time as his acclimatization is complete. There will be means for frequent weighing of the infants and apparatus for preparing milk according to chemical formulae carefully adapted to each child's requirements. In a word, there will be concentrated into this part of the maternity hospital all the devices of science and all the care of the obstetrical and nursing staff for that campaign

of neo-natal life saving which has here its special *terrain*. There will, of course, be special difficulties, such as the maintenance of touch between the babies and their mothers, but these are all capable of being overcome. When well enough the mothers will be welcomed in the ward and taught the nursing of delicate babies. The inmates will be all the babies born in the hospital or brought in from outside who call for special care because of injuries in labour, of delicacy of constitution, of the presence of disease, or, and most particularly, of prematurity of birth. A special place and differentiated handling will be afforded for the syphilitic babies and for those suffering from ophthalmia neonatorum. The age of the babies dealt with in the neo-natal ward will correspond with the name of the department; but here it is necessary to add a word of explanation. The ordinary neonate remains such for, roughly, a month after birth; but the fetus born at the seventh month of ante-natal life does not conclude his neo-natal existence till three months after his birth. If this obvious fact had been more generally recognized and acted upon there would not now have been so many neo-natal deaths recorded; such deaths were really ante-natal and not neo-natal in time, although they fell accidentally after the act of birth.

New Responsibilities.

The addition of ante-natal departments to maternity hospitals and their reinforcement with neo-natal departments has had and will have the effect of increasing the responsibilities of these institutions as well as of widening the range of their usefulness; but it will do more. It will increase—indeed it already has—the responsibilities of the hospital as a teaching centre. Both for medical students and nurses in training as midwives it is necessary to supply clinical instruction in the ante-natal and neo-natal departments. It is more than time that the exclusive or at least preponderating attention paid to teaching on the parturient and puerperal patient tacitly enjoined by the present regulations of the General Medical Council be extended and that tuition in ante-natal clinics and in the ante-natal and neo-natal wards be at least recommended in addition to the more usual and compulsory part of the training. It is, of course, essential that future practitioners should know about the handling of labours and the management of the puerperium, but it is most desirable that they shall be made familiar also with the examination of pregnant patients at all stages and with the hygiene and maladies of newborn, and especially of prematurely born, infants. Further, these additions will give a scope and a status to clinical obstetrics such as it does not now enjoy. It will then be a more complete presentation of the subject and will be less meagre in its content in comparison with clinical medicine and clinical surgery than it is at present.

The teaching of theoretical obstetrics will in turn be similarly affected. The lecturer will be led to give and pay more time and attention to ante-natal diagnosis and pathology and to neo-natal hygiene and disease than he commonly does now; and, again, as with the clinical aspects of the subject, a greater fullness will be introduced. The term "midwifery" is more truly descriptive of the teaching given to women in training for the examinations of the Central Midwives Board; something which both in nature and in extent surpasses this is what should be offered to the medical men and women of the future. The lectureship or chair might have been given the eminently and correctly descriptive name of genetics, but that term has been appropriated. Apparently we must fall back upon the term obstetrics, using that word in its widest sense.

The bearing on gynaecology of these ante-natal and neo-natal additions to the equipment of a maternity hospital is not necessarily direct. In Edinburgh the gynaecological department is in the Royal Infirmary, but in many places it is conjoined with the practice of the maternity hospital. In some respects this is admirable, for one large part of a gynaecologist's work is devoted to the repair of injuries and their results which are directly or indirectly due to faulty midwifery, and there is a distinct advantage in their being carried out in the same building. Thus the gynaecological department of a maternity hospital would serve the same purpose for the wounded puerperal woman which the neo-natal department discharges for the delicate infant. But it must not be forgotten that another large

part of gynaecology is concerned with the treatment of morbid states, such as malignant and myomatous tumours of the uterus, cystomata of the ovaries, and malformations, which have no obvious or common connexion with child-bearing. These are best dealt with in a surgical hospital, for they are really nowadays a part of surgery. It looks almost as if gynaecology were on the point of breaking up into two parts—one containing conditions due to or militating against childbirth, and the other dealing with diseases and tumours common to surgery and gynaecology, and special only in respect of the sex of the individual suffering from them. For the management of the first subdivision of gynaecological cases a department in the maternity hospital would be perfectly suitable; for that of the second subdivision the gynaecological ward of the general hospital would seem to be appropriate. The progress of the art and practice of obstetrics, as reinforced and aided by the work of the ante-natal department, will be in the direction of limiting more and more the occurrences calling for reparative gynaecological operations, and happily, in time, of abolishing them altogether.

THE TREATMENT OF UTERINE HAEMORRHAGE NOT ASSOCIATED WITH PREGNANCY.

BY

JAMES PHILLIPS, F.R.C.S. EDIN.,

HONORARY SURGEON, BRADFORD ROYAL INFIRMARY.

IN normal menstruation, when the superficial layers of the endometrium are cast off and blood is extruded from the abraded surface, clotting takes place very rapidly with abundant fibrin formation. Whitehouse¹ says: "The high thrombo-kinetic [blood-clotting] power of the endometrium is a provision of nature to facilitate clotting and prevent excessive haemorrhage. Even in well-marked cases of haemophilia profuse haemorrhage very rarely occurs during menstruation . . . Clinically . . . it is well known how rapidly, during the operation of curetting, the blood clots when mixed with the curetted endometrium, and special precautions are necessary to obtain tissue for microscopical purposes unmixed with clot." If, however, normal menstrual blood is examined after it has reached the vagina, it will be found to be almost completely fluid. Blood collected from the uterine cavity in a test tube is found to clot rapidly, but after some hours it becomes liquefied again. In other words, there is not only a blood-clotting substance present, but also a clot-dissolving substance, which normally produces liquefaction of the blood in the vagina, and so facilitates the evacuation of the menstrual discharges. There is evidence which suggests that the stroma cells of the endometrium secrete the clotting substance and the uterine glands the liquefying substance.

That ovarian secretion also exercises a profound control over menstruation is certain, and most probably the hormones of other endocrine glands are also potent, but little is known of how these act. Mechanical factors no doubt come in—for example, uterine muscular contractions may reduce menstrual loss by limiting the supply of blood to the endometrium. But the broad fact remains that the amount of menstrual bleeding is determined by the balanced action of various internal secretions about the mechanism of which we are at present without the knowledge which would enable us to control or regulate it. In practice we find that excessive menstrual loss usually occurs about the age of puberty or when the menopause is approaching. Excessive uterine haemorrhage during the child-bearing period is almost always associated with organic disease of the uterus or with some blood disease. The most frequent cause is, of course, fibroid tumours, and when a fibroid is accompanied by severe bleeding it will almost always be discovered either to be involving the endometrium, and thus likely to modify its secretory action, or it has itself undergone some degenerative change—necrobiosis, mucoid degeneration, red degeneration or malignant transformation—with consequent considerable chemical changes.

Until our knowledge has so improved that we are able to control the delicate balance of internal secretions, on

¹ Read at a meeting of the Bradford Medico-Chirurgical Society.

the upset of which appears to depend for the most part excessive uterine haemorrhage, in my opinion it is desirable to perform hysterectomy in all such cases whenever the bleeding is severe enough to make the patient to any extent an invalid. I am old enough to remember the time when it was considered so dangerous to remove a uterine fibroid that gynaecologists more often than not suggested not operation but rest and drugs when a woman anywhere near the menopause had a fibroid which did not actually threaten her life by reason of the profuseness of the bleeding. One of my most vivid memories is of a Sunday in 1896 when, on coming away from a visit to a lady of some 50 years of age, who had spent perhaps a dozen years constantly lying down either in bed or on a couch in an adjoining room, I was told that she had been all these years awaiting the cessation of a metrorrhagia due to a fibroid. I had watched Greig Smith remove large myomatous uteri safely and easily, and had seen more than one blanched feeble creature return a few months later to thank the surgeon for renewed vigorous health; and the contrast of a highly educated woman, whose keenly enjoyed activities had been brought to an end at the age of 40, was my first big stimulus to do surgical work—not just to save a patient from impending death, but from the far more ghastly death-in-life which constitutes existence for so many chronic invalids.

Briefly, in turn, bleeding (1) at puberty, (2) during the child-bearing years, and (3) about the period of menopause must be considered. Bleeding at puberty (1) may be severe, but practically always it rights itself, and I never even heard of any case which required hysterectomy. As I have indicated, it is probably due to imperfect balance between the various internal secretions.

Excessive bleeding during the child-bearing years (2) is, as stated before, most commonly due to fibroids, and, in my opinion, hysterectomy is indicated in almost every case where excessive bleeding, either menstrual or intermenstrual, is associated with the presence of a fibroid. Apart altogether from the bleeding or other urgent symptoms, there can be no doubt that fibroids interfere with good health. The association of myocardial degeneration and aortic disease with large fibroids is too frequent to be merely coincidence, and if a fibroid which has been found in the course of an abdominal section for some other condition is removed, the patient is almost certain to remark on her subsequently improved feeling of well-being.

Excessive bleeding may be associated with hypertrophy of the ovaries.

A year ago I operated on a patient of Dr. Lankester at the Bradford Royal Infirmary. She was a young woman, aged 25 years, who had had six children, and since her last confinement had had too frequent and profuse haemorrhage. When she was admitted she was obviously blanched, and had a soft, low tension pulse. The uterus was slightly subinvolved but otherwise appeared normal. I kept her in bed for a few days until her general condition had improved, and then did a subtotal hysterectomy. She had the most hypertrophied ovaries I have ever seen. Whitehouse has treated such cases by repeated curettage without success. He suggests partial excision of the ovaries, but does not quote any case which has been successfully so treated.

It is, however, about the menopause age (3) when the most trying and frequent cases of haemorrhage occur.

(a) In cases of cervical cancer, by the time the growth has developed sufficiently to produce considerable haemorrhage it is practically certain to be too far advanced for radical treatment.

(b) Bland-Sutton has suggested that uterine fibrosis is the cause of many cases of severe uterine haemorrhage at the menopause, and in a not very large percentage of uteri removed for this condition thick-walled blood vessels can be demonstrated.

(c) A condition much more frequently found is one which affects chiefly the endometrium, known as hypertrophic glandular endometritis, but the microscope does not usually show the small cell infiltration indicative of inflammation; and it would probably be more correct to regard the condition rather as a degeneration of the endometrium. The uterus is rarely much if at all enlarged. It may be retroplaced, but is more frequently in normal position. There is, as a rule, nothing abnormal found about the appendages. After removal the uterine wall is, on section, distinctly pale, but the obviously abnormal condition is an oedematous thickened endometrium, usually in places forming one or more mucous polypi from 1 in. to over 1 in. in length. I

have hardly ever seen any blood clot in the uterus in these cases even when the operation has been undertaken as an emergency for severe active haemorrhage—which points, of course, to a probable deficiency of thrombokinae (blood-clotting substance).

(d) In other cases of irregular menopausal haemorrhage no abnormality is discovered in the uterus, either macroscopically or microscopically.

I think there can be little doubt that in all these cases, whether an obvious lesion of the uterine wall or of its living membrane exists or not, the essential cause of the bleeding is an abnormality in the internal secretions. Some day we may learn how to regulate the functioning of these substances, but until we do I am strongly of the opinion that whenever the bleeding is so severe and so persistent as to make the patient's life a burden to her, the only certain means of curing her is to remove the uterus. Packing the vagina, curettage, ergot and similar drugs are most uncertain remedies and at best produce only temporary improvement. For beyond a doubt the patients who consult their doctors about bleeding of this sort as a rule never feel well; apart altogether from the haemorrhage there are symptoms, none of them perhaps very bad, but in the aggregate producing a sense of illness enough to make most women willing to risk operation in order to get rid of it, if they are not definitely discouraged by their medical attendant.

REFERENCE.

H. Beckwith Whitehouse's Hunterian Lecture on Physiology and Pathology of Uterine Haemorrhage, February, 1914 (*Lancet*, March 23rd, 1914).

SOME DEDUCTIONS FROM THE STATISTICS ON THE PREVENTION OF PULMONARY TUBERCULOSIS.

BY

D. H. C. GIVEN, M.D., D.P.H.,
SURGEON COMMANDER, R.N.

STATISTICS show us that, in spite of all that has been said and done for the prevention of tuberculosis, our efforts in regard to pulmonary tuberculosis have not been attended with the anticipated success. The decline in mortality from this cause dates from 1838, and has continued steadily ever since down to 1913. Koch's discovery of the tubercle bacillus in 1882 does not appear to have affected it in any way. On comparison of the statistics of the four principal zymotic diseases (measles, scarlet fever, whooping-cough, diphtheria) with those of pulmonary tuberculosis, in the fifty years 1861-1910, we find the following decline:

Comparison in Deaths per Million Living.

	1851-70.	1871-80.	1881-90.	1891-1900.	1900-10.
Zymotics	2,061	1,633	1,367	1,219	909
Pulmonary tuberculosis	2,590	2,231	1,810	1,418	1,143

Representing a decline of 55.89 per cent. in zymotics and of 57.86 per cent. in pulmonary tuberculosis.

Comparing the average mortality per million living in the first six years of the period 1902-1913 with the last six years, in the air-borne diseases the following result is found: Pneumonia shows a decline of 14 per cent., phthisis of 11.6 per cent., bronchitis of 10.68 per cent., and the four principal zymotics of 21 per cent. Pulmonary tubercle is only one of the air-borne group of diseases. The chart below, prepared from the statistics of the Registrar-General for 1916, shows clearly that whatever the causes of these diseases, the same causes are common to the whole group. The death rates from the individual items that go to form the group show corresponding variations in different sections of the population. The curve of tubercle shows a slight deviation only from the other diseases of the group in the case of London and Southend, but I think this is explained from the fact that London is a big hospital centre, while Southend is one of our health resorts. It will be seen that for the whole of England and Wales and for the other sections of the population bronchitis causes a higher death rate than pulmonary tuberculosis.

As we all know from experience that all these diseases are closely associated. The statistics show us that zymotic diseases expend themselves as regards fatality in the first fifteen years of life. Accounting for over 26 per cent. of

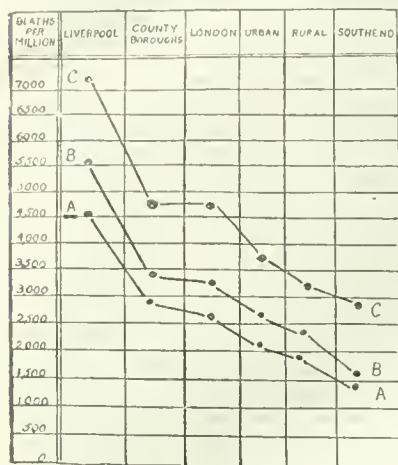

Air-borne diseases, representing three of the five principal causes of death in sections of the community. A Curve: Bronchitis, pneumonia, and other respiratory diseases. B Curve: Ditto, plus zymotic diseases. C Curve: Ditto, plus consumption.

curve of pulmonary tubercle, which, starting with 2.29 per cent. in the 1-5 age period, 10.43 per cent. in 5-15, reaches its maximum of 33 per cent. in the age period of 15-25.

The researches in regard to cerebro spinal fever have done much to elucidate the problem of the source of respiratory infection. (BRITISH MEDICAL JOURNAL, September 18th, 1920.) It has been demonstrated how readily the meningococcus passes from throat to throat in an overcrowded community, and how rapidly it disappears with efficient ventilation and spacing out. The carrier rate rises twice as rapidly in the presence of sufferers from catarrh, so that for the prevention of outbreaks of meningitis it is more important to isolate the people suffering from colds than it is to isolate carriers.

Again, quoting from the *Australian Medical Journal* of June, 1920, in regard to the etiology of pneumonia, as the result of war experience, "Pneumonia is probably due to many factors, of which the association with persons suffering from catarrh is the most important." "Victor Vaughan found that the incidence of pneumonia among American soldiers in training camps fell when overcrowding and bad ventilation were removed." "Catarrh affects persons whose naso-facial tissues are unhealthy . . . A person with a normal nose and throat does not acquire a catarrh." The same probably applies to the "carrier" condition. Experiments to inoculate a healthy nasopharynx with pathogenic organisms, so far as they have been attempted, have been a failure. The healthy mucosa readily disposes of them. Again, what is bronchitis, which causes more deaths every year than consumption, other than an extension of the common cold where the resistance is low or where it has been reduced by repeated attacks? Over 20 per cent. of consumptives give a history of repeated colds in the head (Osler and McCrae). Putting two and two together, therefore, the common cold is probably the most important connecting link between all respiratory infections; it is the means of (1) disseminating air-borne disease, and (2) of preparing the soil for further invasions or for the condition of carrier.

In conclusion, I feel convinced that the campaign against consumption must be directed against the air-borne diseases as a whole, and against the common cold in particular. The effects of other respiratory infections, including the common cold and zymotic diseases, in early life is to prepare the soil for the later invasions of the tubercle bacillus when otherwise resistance should be high. The remedy for all these diseases is a matter of improved housing and education in ventilation and general hygiene, yet at the same time much could be done meanwhile by the more thorough recognition and treatment of the common cold and its sequelae.

THE RELATION OF TEMPERATURE TO THE ONSET OF A CARDIAC IRREGULARITY.

BY
R. MACNAIR WILSON, M.B., CH.B. GLAS.,
LATE CARDIOLOGIST TO THE WAR OFFICE TRENCH FEVER COMMITTEE.

MUCH has been written on the effect of temperature on the appearance of cardiac irregularity, and notably of the extra-systole. According to a number of observers there is a tendency for extra-systoles to disappear during high temperature, with a rapid pulse rate, after the manner in which they tend to disappear during exertion. Without any desire to controvert this view, which indeed is supported by much evidence, the following case is presented as affording in one direction a remarkable illustration of an opposite state of affairs, and possibly a sidelight on the etiology of this type of irregularity.

The patient, a young miner, was admitted on September 23rd, 1917, to the War Office Trench Fever Hospital, Hampstead, on the forty-second day from that on which he had contracted an attack of trench fever in France. When first seen he was suffering a typical relapse of this condition with backache, headache, hyperalgesia of his shins, muscular pains in the legs and shin-bone pain. He himself was well able, from his experience, to diagnose what was wrong. His temperature was then 103° F., his pulse was markedly irregular, and a prolonged polygraph tracing was taken. It was found that the irregularity was itself singularly regular, an extra-systole ventricular type occurring every third beat. Only very occasionally were there

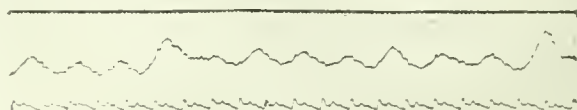

FIG. 1.

"runs" of regular rhythm, and these lasted for but a few seconds when they occurred, and then gave place to irregularity again.

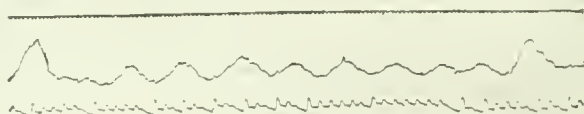

FIG. 2.

The first tracing was taken at 7.10 p.m. At 9.20 p.m. the temperature had fallen slightly, and the pulse was 100, but the extra-systoles were less frequent. At midnight the temperature was 101° F., the pulse 100, and the extra-systoles less frequent still.

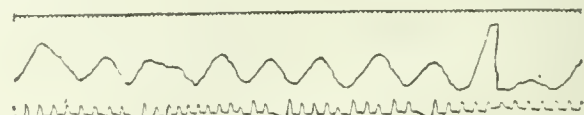

FIG. 3.

At 10 a.m. the next morning the temperature was 97.7°, the

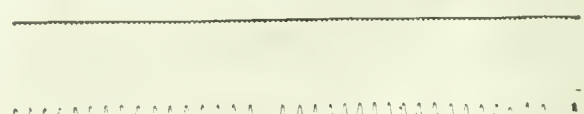

FIG. 4.

pulse rate 81, and there were no extra-systoles. The symptoms had markedly abated.

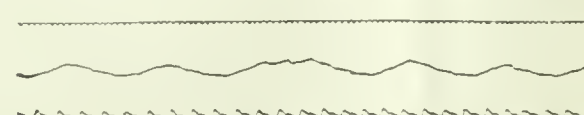

FIG. 5.

An interval of six days then elapsed, during which, so far as could be determined, there were no extra-systoles. On October 1st, however, the patient began to complain again, and took to his bed with a temperature of 102.5° F., and with a large number of extra-systoles—though not so regular an irregularity as on the first occasion. His pulse rate was 110. He had pains and aches

as on his first attack. Next morning he was well, with but an occasional extra-systole, and no further notice of him was taken until three days later, when his temperature went up to 104° F.; pulse rate 110. He was now found to have a perfectly regular pulse, and he had no muscular pain, headache nor backache. He had, however, marked abdominal pain and diarrhoea. (In his former attacks he had been constipated.) His pulse is here shown. (Fig. 6.)

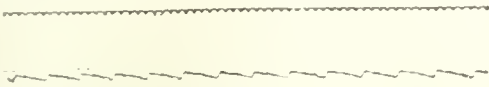

FIG. 6.

From this point not a single extra-systole was observed until October 15th, though the temperature remained high for a week, reaching normal only on the 12th. On October 10th rose spots appeared on the abdomen, and paratyphoid B was found bacteriologically to be present. The pulse rate did not rise above 100 after the first day; on October 8th it was 90, and on the 10th 75.

On October 16th slight pain returned to the legs, which had been quite free from this symptom—most unusually, as he stated—and a few extra-systoles appeared. These continued off and on till the 22nd. On the 23rd his temperature again rose, and reached 103° F. on the 26th, but without pain or headache. He was sure this was not his trench fever, and had no extra-systoles. The pulse was 130. Temperature and pulse fell to normal on the 28th, and some extra-systoles at once appeared. On November 1st, another attack with pain and headache came on, and this was accompanied by a few extra-systoles.

The interesting point is that when they appeared the bouts of extra-systoles were always accompanied by trench fever symptoms, and that an exact eight-day periodicity was

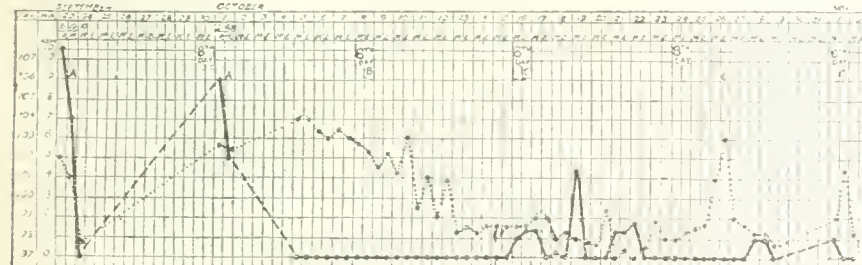

FIG. 7.—Heavy line = extra-systoles per minute. Dotted line = temperature. A, Typical trench fever. B, Diarrhoea and abdominal pains. C, Trench fever pains. D, Abdominal pains; no trench fever pains.

shown in their onset. This is shown in Fig. 7. The temperature is also shown.

It is thus evident that the toxin of trench fever in this case produced a different effect on the rhythm of the heart from that produced by the toxin of paratyphoid B. Extra-systoles are relatively common in cases of trench fever.

THE HERPES-VARICELLA INFECTION.

BY

A. E. CARVER, M.D. CANTAB., M.R.C.P. LOND.,
HONORARY PHYSICIAN, TORBAY HOSPITAL.

GENERAL recognition has as yet scarcely been accorded to the contention, which was first advanced by Bokay¹ of Budapest twenty-nine years ago, and in support of which convincing evidence has been accumulating during the last few years, that herpes zoster and varicella own a common causal agent and are intercommunicable.

Further attention in this country was drawn to the association between these diseases by Dr. Le Feuvre in 1913, writing from Balawayo. He reported nine cases in the *Guy's Hospital Gazette* and the *Medical Journal of South Africa*, in which varicella followed upon contact with herpes zoster; and others in which a varicella rash occurred in persons already suffering from herpes—the generalized rash appearing within five days after the appearance of the localized herpetic eruption. In this latter connexion he quoted a very pertinent observation by Adamson,² to the effect that in cases of herpes isolated vesicles may occur "sparsely scattered over all parts of the body," and suggested that this is in fact a scanty varicella eruption. It must be seldom that comprehensive search is made in a patient suffering from herpes for vesicles scattered over other parts of the body, but if this statement be generally corroborated it will constitute an

important link in establishing the contention that the two diseases are of identical origin.

Since Le Feuvre's first communication over fifty well authenticated cases have been reported in which varicella developed in persons who had been intimately associated with patients suffering from herpes zoster, and in each instance the probability of the infection having been contracted from other cases of varicella could be excluded.

Moreover, the interval between the appearance of the herpetic eruption in the one patient and that of the varicella rash in the other was within the recognized incubation period of the latter disease, or exceeded that period by no more than one day. Thus, in 51 cases in which the necessary dates and details are given this interval was:

10 days in	18 days in
12	1	19	5
13	6	20	1
14	13	21	5
15	2	22	1
16	4	From 8 to 20 days	in	3	
17	1				

It is somewhat remarkable that of these 51 cases of varicella 8 were adults—rather a high percentage considering the infantile nature of the complaint.

In 1919 Dr. Crauston Low,³ in an illuminating paper rich in bibliography, concluded that these diseases are probably due to the same virus, and made the suggestion that in herpes zoster the infection spreads from the nose along the lymphatics to the olfactory nerves and the cerebro-

spinal fluid; whereas in varicella it is probably a blood infection.

The following history of three cases which occurred in one family last autumn seems to be worth recording. Three children living in a country house were together in a tram on September 4th. This was the last occasion upon which they were away from home together in any enclosed or crowded place. On October 1st one child developed varicella at a school to which she had returned on September 22nd. On October 3rd, another child developed the disease at home, and,

on October 4th, the third child developed it at another school 200 miles away, to which she had gone for her first term on September 21st.

Clearly, the three children contracted varicella independently, yet from some common source; and seeing that they had not been about together excepting in the country during the twenty-seven days preceding the appearance of the rash in the first case, it was at first difficult to explain how this had come about. The two school children had been certified, in good faith, before returning to their respective schools, as having been in contact with no infectious disease during the preceding three weeks, and it was a matter of considerable annoyance to all concerned that two schools should have become infected through them at the beginning of the term.

Whilst staying in the house in which they had spent their holidays the children's grandmother had suffered a very severe attack of supraorbital herpes, of which the eruption began to appear on September 14th. To this patient the children had limited access, and, in view of the fact that contact with any case of varicella can be excluded, the suspicion is very strong that the herpes was the source of their infection. In these cases the herpes-varicella interval was respectively seven, nine, and twenty days from the first appearance of the herpetic eruption.

From the foregoing it appears that, sometimes at all events, herpes zoster is an infectious disease, contact with which is not rarely followed by varicella; but I have been able to find no recorded instance in which herpes in one patient has clearly given rise to herpes in another patient.

In all the cases that have been reported the varicella infection appears to have been contracted during the period of onset and development of the herpetic eruption, and no case has been reported in which it occurred as a result of association with herpes in its later stages. It is questionable, therefore, at what period of the attack the infection

from the herpetic person ceases to be communicable. From experience we know that varicella itself is highly infectious during the period of onset, and it is authoritatively laid down that persons suffering from varicella continue to be potential sources of infection until a new epidermic covering has spread over the site of the pocks, that is, until all scabs have separated, upon which precept practice is generally based; but until evidence is forthcoming that the period of infectivity similarly persists to the end of the attack of herpes, it would be unjustifiable to place a contact in quarantine until three weeks after the last herpetic scab had come away.

It must be admitted that the argument is not complete. Careful inquiry is necessary to elucidate the problem of where and how the herpetic infection is originally acquired. Then again, many cases of herpes zoster occur to which no spread of infection has been traced; and this raises the further question whether all cases of herpes zoster are in fact etiologically identical, or whether some are due to one infection, others to another infection, and others again to a process of a different category altogether.

REFERENCES.

¹BRITISH MEDICAL JOURNAL Epitome, 1913. ²H. G. ADAMSON, *Skin Affections of Childhood*. BRITISH MEDICAL JOURNAL, 1919.

Memoranda:

MEDICAL, SURGICAL, OBSTETRICAL.

ASSOCIATION OF HERPES ZOSTER AND VARICELLA.

IN view of the recent correspondence in the JOURNAL on the subject of the association of herpes zoster and chicken-pox, I think the following note may be of interest, and also helpful in making record of such cases.

On January 10th last Mrs. X. came to see me because of a rash on her body. This proved to be typical herpes zoster along the course of one of the upper left intercostal nerves. She asked me at the time if there were any fear of infecting anyone else, and I assured her that it was most unlikely, and that I had never known such a thing to occur in my own experience.

On January 25th—that is fifteen days after the herpes zoster appeared—I was asked to see the elder daughter. She had a temperature of 103° and a typical rash of chicken-pox. Some of the spots were well in the blister stage, and others were still coming out in crops at different stages. Three days later the younger daughter also developed typical chicken-pox. Both daughters had chicken-pox twenty years ago, the elder slightly and the younger more severely. To their knowledge none of the family had been in contact with any infectious disease. The incubation period of chicken-pox being usually eleven to fifteen days, it follows that had Mrs. X. suffered from chicken-pox instead of herpes zoster no one would hesitate to say that the daughters were infected from her. After the above experience I think it would be wise to be guarded in one's statements in regard to the possibility of infection from a case of herpes zoster.

W. MORTON ROBSON, M.D.Lond.,
F.R.C.P.Lond.

Northampton.

A CASE OF TETANUS.

THE following case seems worthy of record, in view of the facts that: (1) there was, after the most careful scrutiny of the patient, and after investigation by the interpreter, no evidence or history of the minutest injury having occurred; (2) the case steadily improved, and finally recovered under treatment by the intramuscular method alone.

The patient (a German) reported sick to the medical officer in command of the prisoners of war compound in June, 1919, complaining of stiffness in the neck and feeling unwell. His temperature was not raised. He was "excused duty" and told to report next day. For the next three days he reported, but complained of nothing more than he did on the first day. On the evening of the fourth day he developed stiffness in the jaw and difficulty in swallowing, and was immediately sent to No. 42 Casualty Clearing Station at Douai diagnosed as (?) tetanus.

On admission the patient had an anxious expression, risus sardonicus was present, trismus was very marked, and swallowing difficult. There was great rigidity and tenderness of the

muscles of the neck, the abdominal muscles were rigid and hard, the legs and arms rigid. Spasms were present, but not frequent, nor were they very severe; respirations were good. The temperature was 97° and the pulse 72. There was no evidence of cervical glandular inflammation, oral sepsis, carious teeth, or any other affection which might possibly give rise to the condition the patient presented.

Active antitetanic treatment was commenced at once, and within the first forty-eight hours of admission 52,000 units of antitetanic serum were injected intramuscularly. On the third day 8,000 units were injected, and for the next six days the daily dose was 9,000 units. On the tenth day no serum was given, and on the twelfth day a final dose of 1,500 units was injected, making altogether a total of 115,500 units administered in twelve days. The serum used was the concentrated form supplied by the Department of Hygiene, University of Toronto, a supply of which the A.D.M. stores fortunately had in stock at the time.

On the third day after admission the patient's temperature rose to 101°, at which level it remained more or less constant for seven days, when it gradually declined and became normal on the twelfth day. Constipation was very marked for the first five days, and required treatment. Sleeplessness and restlessness were also marked during the same period. By the seventh day the trismus was slightly lessened and the teeth could be just separated. From the eighth day onwards the trismus and muscular rigidity steadily diminished and the patient improved, until, on the twentieth day after admission, all signs and symptoms of the disease had disappeared. Shortly after this date the patient was up, and after a brief convalescence he was usefully employed for several weeks helping to look after the other German patients in hospital.

The outstanding features of the case may be summarized as follows:

1. No evidence of injury.
2. Rigidity of muscles of neck (later of abdomen and limbs).
3. Marked trismus.
4. No respiratory embarrassment.
5. Mild nature of convulsions.

The type of case should be classified as one in which trismus occurred after other signs of tetanus had shown themselves. Local premonitory symptoms occurred in the following order: (1) Pain (in muscles of neck); (2) difficulty in swallowing; (3) muscular rigidity.

Accidents due to serum were absent. There was no anaphylactic shock; there was no reaction, as shown by the temperature, to the injection of the serum in large doses, and there were at no time any signs of a serum rash appearing.

Worcester.

L. T. CHALLENGER, M.R.C.S., L.R.C.P.

MESSAGE OF THE HEART AND RESUSCITATION.

I NOTICE that Professor Gunn, in his paper on massage of the heart and resuscitation (January 1st), expresses surprise that a mechanical pump is not used for artificial respiration in the human subject. I think that other anaesthetists will agree with me when I say that a pump for supplying intermittent inflation of the lungs is unnecessary. If a catheter is passed into the trachea with its distal end at the bifurcation, and if a continuous stream of air or oxygen (pure or etherized) is made to pass along it, the patient's colour will remain pink, and the pulse normal, even although no respiratory movements are taking place. This shows that there is sufficient interchange of gases to oxygenate the blood.

If, however, both pleural cavities are opened, and a very considerable pressure is required to inflate the lungs, it is necessary to let the pressure fall to zero from time to time, or the filling of the heart will be interfered with. Fortunately the number of operations in which this is necessary is small.

I have often thought that there are many other conditions in which insufflation of the lungs is indicated, but which until recently have been regarded as hopeless. For instance, a cerebral abscess or haemorrhage may have caused respiration to cease through increased intracranial pressure. If a tracheal catheter is at once passed, and the lungs inflated with oxygen, life may be maintained for a sufficient time for an operation to be performed.

A short time ago I was called to see a girl of 10 in *extremis* with bronchopneumonia and pericarditis. She was quite unconscious; the lips were purple, and she was giving about eight gasping respirations per minute. No carotid or radial pulse could be detected. I was struck with the similarity she presented to a deeply anaesthetized patient with a partially obstructed airway. In both there were two morbid conditions: (1) the obstruction, and (2) the toxin, which was chemical in one and bacterial in the

other. As soon as possible I passed a catheter into her trachea by means of a bronchoscope and turned on a gentle stream of oxygen. By this time respirations had entirely ceased; the pupil was dilated and fixed, and no corneal reflex was present. At the end of two minutes the colour of the lips was pink, the corneal reflex returned, and the radial pulse became palpable. This, I think, was the more remarkable as the girl had previously had pituitrin 1 c.cm., strychnine gr. $\frac{3}{5}$, and inhalation of oxygen with no effect whatever. At the end of five minutes a considerable amount of mucus had been blown out of the trachea, and the patient's condition was much better. Unfortunately the improvement was not maintained, and she died later; but I think that the result justifies the employment of this treatment in chest conditions where the right heart is obviously giving out from the effects of the toxin, the pressure, and the deficient oxygen supply; the latter factor can at any rate be remedied, while the respiratory obstruction can also be relieved to a certain extent by the mechanical removal of secretion.

London, W.

C. LANGTON HEWER, M.B.

Reports of Societies.

ACTION OF RADIUM AND X RAYS ON TUMOUR GROWTH.

At a meeting of the Royal Society, held on January 27th, with the President, Professor C. S. SHERRINGTON, in the chair, Sir WALTER FLETCHER communicated a paper on the "Local and generalized action of radium and x rays upon tumour growth," by Professor S. RUSS, D.Sc., Dr. HELEN CHAMBERS and Miss GLADWYS M. SCOTT. The paper recorded an investigation made with the object of finding the effects of the beta and gamma rays from radium and x rays upon rat tumours under varying conditions. The local effects were obtained by exposing the tumour only to measured quantities of radiation, the animal not sharing to an appreciable extent in the irradiation. When large doses were employed, destructive action upon the tumour cells was observed; as the dose was reduced, the action tended to become stimulative in character, so that the tumour cells grew more rapidly than they would had they received no radiation. The generalized effects of the rays used were obtained by submitting the whole animal to the radiation, the tumour in the animal being screened by the use of suitable screens. It was found that large generalized doses could not be borne by the animals; when, however, they were given repeated small doses an increase in body weight and an increase in resistance towards tumour growth was observed. Under the usual conditions of radiation treatment in malignant disease in man the body shared to some extent in the radiation administered to the tumour, and the bearing of the present observations in this connexion was discussed.

TREATMENT OF FRACTURES.

A GENERAL meeting of the Border Counties Branch of the British Medical Association was held at the Lowther Hall, Carlisle, on January 14th, at 3.30 p.m. In the unavoidable absence of Dr. Livingstone, the Branch president, Dr. BOWSER of Penrith took the chair.

Major MERRIE SINCLAIR, C.M.G., R.A.M.C., gave a lecture on the treatment of fractures, and illustrated his methods by showing patients who had been put up in the splints used for the various fractures of the upper and lower extremities. The principles which governed the choice of the apparatus and the mode of application were thoroughly explained in each case. After a short interval for tea Major Sinclair showed a set of x-ray lantern slides of fractures which he had treated. A most cordial vote of thanks was passed to him on the proposal of Dr. CULLIN, seconded by Dr. GREGAR. Between sixty and seventy medical men and nurses were present.

A joint meeting of the Midland Branch of the British Medical Association and the Nottingham Medico-Chirurgical Society was held on January 20th, when, by permission of the Director-General of the Army Medical Service, Major SINCLAIR gave a demonstration at the General Hospital, and a lantern lecture at the Medico-Chirurgical

Society's rooms, on fractures of the femur. Major Sinclair brought with him fifteen of his modifications of the Balkan beam, and the splints were shown in position on patients. The lecturer briefly described the Thomas splint and the principles of its action, and then showed a method of applying the splint as a first-aid treatment, in which an iron keiser inserted through the boot upper close to the sole was used as an attachment for extension, and the splint was slung to metal frames attached to the sides of the stretcher. The Thomas splint was then shown as used for the treatment of fractured femurs, and the lecturer emphasized the necessity (1) of preserving the normal forward arch of the femur; (2) of maintaining the foot in a position of eversion during the treatment; (3) of bending the splint near the knee-joint, especially in fractures of the lower third of the femur. The value of the treatment was explained and shown.

For cases which did not respond to ordinary extension with flannel and Sinclair's glue, the lecturer advocated extension by screws inserted into the upper end of the shaft of the tibia, and explained their advantages over callipers applied to the femoral condyles. He maintained that no permanent disability resulted from stretching the ligaments of the knee-joint by extension applied to the tibia. At the close of the demonstration the lecturer showed his various modifications of the Thomas arm splint and his special splints designed for fractures of the wrist and hand. The results shown were very striking, and at the close of the lecture the thanks of the Society and the Association were voted by acclamation to Major Sinclair for his practical and interesting demonstration and lecture. The demonstration and lecture were repeated on the following day for the nursing staffs of the general and neighbouring hospitals.

As a result of this demonstration it is expected that the various collieries and ambulance stations in the county will be equipped with Thomas splints for first-aid treatment of fractures of the lower extremity.

Rebicus.

PHYSICAL SIGNS.

In his well-written manual *Physical Signs in the Chest and Abdomen*, Dr. A. J. JEX-BLAKE¹ has successfully carried out a task that is more difficult than the elementary nature of the subject matter might at first sight suggest; such manuals being indeed hard to make attractive, often prove dull to the reader. Those who gain the basis of their knowledge of physical diagnosis under Dr. Jex-Blake's direction will do so with greater ease and interest than fell to the lot of some of their seniors; for the text is not a mere recital of stereotyped physical signs, but is brightened by occasional touches and practical hints, shrewd and even slightly whimsical, and contains remarks on the interpretation of the signs set forth in a manner showing the independence derived from a long experience in teaching. Thus variations from the normal, such as dilated venules on the chests of emphysematous persons sometimes regarded as of pathological significance and even dignified by a special Latin name, which have no important bearing, are mentioned only in passing. The use of the sphygmomanometer, polygraph, electrocardiograph, and x rays is not described on the ground that these methods are not, as a rule, available for the individual student or practitioner of medicine; as regards the blood pressure estimations, this decision appears to be one that might be reconsidered when revision for a second edition becomes necessary. In this respect the sphygmomanometer is hardly out of the same plane as the electrocardiograph.

The work is divided into three parts; more than half the book is devoted to the examination of the chest, which is followed by a description of the physical signs of intrathoracic disease, and then by the section on the examination of the abdomen and an account of abdominal swellings. Under the heading of palpation, teaching for superficial tenderness appropriately finds a place with a table of the chief cutaneous areas in which referred pain and super-

¹ *Physical Signs in the Chest and Abdomen*. By A. J. Jex-Blake, M.V., M.D., F.R.C.P. (London: J. and A. Churchill, 1921. Demy 8vo, pp. 112; 27 figures, 9s. 6d. net.)

facial tenderness occur in visceral disease, and of their innervation; attention is drawn also to Dr. H. Head's observations on the reflex headaches and tenderness of the scalp secondary to disease of any of the thoracic or abdominal viscera. The appearance produced in the lower part of the abdomen by a distended urinary bladder is compared to that represented in Donatello's statue of David; this condition is said to reproduce, on percussion, the thrill characteristic of a hydatid cyst.

A CONSULTING SURGEON IN THE NEAR EAST.

The record of Mr. Tubby's experiences as a consultant in the Near East² will have an interest—a melancholy one in some cases—for those who served with the Egyptian and Dardanelles Expeditionary Forces during the earlier years of the war. He has portrayed in a highly tolerant spirit the conditions under which medical and surgical aid was brought to the sick and wounded during these strenuous years. He records much that might have been bettered had the magnitude of the task which the landing in Gallipoli involved been more fully appreciated. He finds much to excuse and no little to admire in the gradual evolution of order out of chaos. That the consultant surgeons in the theatre of war had much to do with the improvement in the character of the surgical relief afforded to our troops there can be little doubt from Mr. Tubby's record, but one reads with some surprise that for more than a year the services of consultant physicians were not made available for the assistance of hospital and administrative authorities. This is all the more remarkable in view of the fact that so many officers of the Indian Medical Service—whose experience of tropical maladies is unrivalled—were at that time serving in the Near East.

The deplorable dearth of x-ray apparatus during the year 1915, at a time when they were most urgently required, was a matter that aroused the deepest concern on the part of all surgeons. Sir Victor Horsley from the moment of his arrival in Egypt had agitated for immediate action in this matter. We learn, therefore, with surprise from Mr. Tubby's narrative that it was not until the lapse of several months that the steps taken by the consulting surgeons to secure the proper provision of these indispensable aids to surgical diagnosis and treatment were at length attended by success.

Mr. Tubby's narrative of events in Palestine, and his comments on the duties, rank, status, and emoluments of the consultant surgeon, will be read with interest. The book is provided with a double index—one of names and one of subjects. It has a number of interesting illustrations. As a record of work attempted and achieved the book is of value. From its perusal one gains the impression that the consultant surgeon of the future should be one to whom the quotation with which Mr. Tubby opens his fourteenth chapter applies—"Now Mr. Great-Heart was a strong man, so he was not afraid of a lion."

AN ABSTRACT OF UROLOGY.

The *Précis d'Urologie*, by Félix Legueu and Edmund Papin,³ fulfils admirably the purpose for which it was written. The work is well named; it is a *précis*—concise, clearly written, and excellently illustrated. Altogether it is a work worthy of its eminent authors and of the distinguished school of urology to which they belong. In England genito-urinary surgery is apt to be regarded still as an appendage of the general surgeon, and for this reason an English school of urology does not exist; consequently French textbooks on this subject are of especial importance to English practitioners.

The work under review has been divided into three parts: the first deals with methods of examination, the second with signs and symptoms, and the third with the pathology of diseases of the genito-urinary apparatus. The surgical anatomy introduced into the first part is done with extreme thoroughness, and the pictures are unusually good. This excellence in illustration is, however, by no means confined to surgical anatomy. The graphic method of representation has been lavishly utilized throughout. It

would be possible to review rapidly the whole of genito-urinary surgery merely by running through the illustrations to be found in this book without even referring to the text. For example, the various complications of such a complaint as senile enlargement of the prostate are represented in diagrammatic form. Lengthy descriptions are thus avoided, and a clearer and more lasting impression of the subject is conveyed to the reader. The work is not encumbered by historical references or bibliographies, and thus retains throughout its character as a practical *précis*; but for the benefit of those to whom it would be useful, a bibliography is appended at the end.

In their preface the authors state that they have written for the student and the practitioner alike, but the amount of information they have supplied would certainly seem to be sufficient to satisfy also the needs of those who specialize in genito-urinary surgery. Were it not for the fact that the majority of those who have taken up the study of this branch of surgery in England can read French we would urge that an English translation of the work should be prepared. While we retain our appreciation of the larger treatise on urology previously published by Professor Legueu, we believe that this *précis* will meet with a still greater success, and prove itself a still more useful publication.

AN AMERICAN MANUAL OF PSYCHIATRY.

The popular *Manual of Psychiatry*,⁴ of which Dr. A. J. Rosanoff is the editor, has now reached its fifth edition. The volume first appeared in 1905 as a translation of the French textbook by Dr. J. Rogues de Fursac, and anyone who is in doubt as to the progress of psychiatry during these fifteen years would do well to compare the first and fifth editions of this manual. It is especially made evident in the present edition, which contains several new chapters, that psychiatry is no longer a narrow speciality, the activities of which are confined to the institutions for the insane. Not only has it a vital and necessary relation to medicine as a whole, but it finds increasing points of contact with schools and social organizations concerned with the all-important problems of mental hygiene. A special chapter is devoted to psychiatric social work, especially in relation to the training of the social worker and the development of a social service department in hospitals for mental disorder. It is impossible to avoid the reflection that in such directions America is a good deal ahead of this country, and is more fully alive to the needs of the community in respect to the extramural applications of psychiatry.

The attention given to the practical side of psychiatry in this volume may be favourably commented upon. The appendices containing descriptions of the technique of lumbar puncture, cell counts, and chemical tests will be found most helpful to the student and practitioner, and perhaps even more so the seventy pages devoted to a detailed account of the Stanford Revision of the Binet-Simon Intelligence Scale. Much skill and experience is certainly necessary to apply these tests usefully. They contain numerous pitfalls for the unwary, and the instructions herein included would do much to prevent errors. Dr. Rosanoff devotes seventy-four pages to the free association tests (Kent-Rosanoff), a subject in respect to which he is responsible for much original work. The frequency tables will be found of value to those who are specially interested, but the amount of detail given is perhaps in excess of the needs of students.

The chapters concerned with symptomatology and the various clinical groups are not so expressive of more recent developments as are the sections relating to the wider fields into which psychiatry has now extended. The author's treatment is mainly descriptive, and he does not attempt any psychological interpretation of abnormal reactions. An exception is made, however, in the case of hysteria, where attention is devoted to the psychic mechanisms of the disorder. The discussion upon the distinction between hysteria and malingering is vigorous in tone; the tendency to differentiate these conditions on the basis of the conscious or unconscious quality of the motivation is strongly criticized; and there is a good deal

² *A Consulting Surgeon in the Near East*. By A. H. Tubby, C.B., C.M.G., M.S.I. Lond., F.R.C.S. Eng. London: Christophers. (Demy 8vo, pp. xiii + 278; illustrated, 15s. net.)
³ *Précis d'Urologie*. By F. Legueu and E. Papin. Paris: A. Maloine et Fils. 1921. (Demy 8vo, pp. 739; 479 figs. Fr. 59; post free, Fr. 55.)

⁴ *Manual of Psychiatry*. Edited by Aaron J. Rosanoff, M.D., Clinical Director, King's Park State Hospital, N.Y. Fifth edition, revised and enlarged. New York: John Wiley and Sons; London: Chapman and Hall. 1920. (Post 8vo, pp. xv + 664. 22s. net.)

to be said for the view that this vague and subjective criterion "should not seriously occupy the professional mind as a guide in practical work." The author expresses the opinion that the difference is entirely one of view-point. Hysteria is a term stressing the medical view-point and malingering the legal. His opinions as to the motivating factors in the production of hysterical symptoms are expressed with considerable frankness, and a somewhat unflattering picture of the hysterical personality is drawn.

A chapter is devoted to psycho-analysis. It chiefly consists of selected passages from the works of Freud. There is no evidence, however, that Freudian views have to any extent influenced the psychiatric outlook of the author. There are numerous other additions in this volume besides those to which reference has been made, and it may be regarded as having been brought thoroughly up to date. There is no doubt that it will continue to maintain the reputation it has had in the past as a sound and trustworthy textbook, including within a reasonable compass the main facts which the student and practitioner require to know.

SYPHILIS, ESPECIALLY OF THE SKIN.

IN *Syphilis and its Treatment*,⁵ by Dr. WILFRID FOX, the author has written with special reference to syphilis of the skin. Indeed, in our opinion, he would have done well to indicate definitely in the main title of his work that it had been written from the standpoint of the dermatologist rather than that of the syphilologist. The book is the outcome of work done in the venereal and dermatological departments of St. George's Hospital and the Seamen's Hospital at Greenwich. It is intended for the use of medical students and practitioners of medicine.

By far the best chapters are those dealing with cutaneous lesions; this subject is well illustrated, and the plates are very clear. The author has given an excellent description of the various forms of rashes met with in the secondary stage of syphilis, and his paragraph on psoriasiform rashes is good. The table of the various points which enable papulo-squamous syphilides to be distinguished from psoriasis is especially useful. The paragraphs dealing with syphilis of tissues other than the skin and mucous membranes are, on the whole, disappointing, and the same must be said of the chapter on treatment. If intended for the use of students, this chapter should have contained at least one or two illustrations in order to render it clearer. It is difficult for a specialist in writing a textbook on syphilis to avoid giving a false impression of the relative importance of its protean manifestations. Whilst many pages have been devoted to the subject of cutaneous syphilis, only a few paragraphs have been spared for the infinitely more important subject of neuro-syphilis. For this reason Dr. Fox's book must tend to give the student an impression that cutaneous lesions rather than lesions of the central nervous system are the most serious manifestation of the disease.

In dealing with the treatment of congenital syphilis the author speaks in a rather half-hearted way of the use of the salvarsan preparations. Intramuscular injections of galyol he is inclined to consider too painful for so young a subject as an infant; in older patients, whenever a suitable vein can be discovered, he suggests the adoption of the ordinary methods of intravenous injection. In our opinion the results recently obtained from the use of arsenical preparations in congenital syphilis are sufficiently good to justify its routine use in such cases. The insertion of the final chapter on syphilis and public health is to be welcomed. The more fully the medical profession becomes acquainted with the importance of venereal disease as a factor in public health, the more likely is the subject to receive the attention and consideration that it merits.

As we have indicated, Dr. Wilfrid Fox has written an excellent work on the cutaneous manifestations of syphilis, but he has not succeeded so well in his attempt to make it a general treatise on syphilis.

⁵ *Syphilis and its Treatment; with Special Reference to Syphilis of the Skin.* By W. S. Fox, M.A., M.D., B.C. Cantab., M.R.C.P. Lond. London: H. K. Lewis and Co. Ltd. 1920. (Roy. 8vo, pp. 205; 59 figures, 15 plates. 36s. net.)

THE SCHOOL OF SALERNUM.

THE increasing number of lovers of medical history will welcome the appearance of the volume containing, in addition to Sir John Harington's English version (1607) of the *Regimen Sanitatis Salernitanum*⁶ and the Latin text used by Sir Alexander Croke, two interesting introductory articles by Dr. F. R. PACKARD on the history of the school at Salerno, and by Dr. FIELDING H. GARRISON on the pre-history of the *Regimen Sanitatis*. There are also critical notes on the texts of the poem. Dr. Packard accepts the view, and quotes Croke's arguments in favour of, the widely accepted belief that the poem was composed for Duke Robert, the eldest son of William the Conqueror, who visited Salerno to obtain treatment for a poisoned wound. Dr. Garrison, however, follows Sudhoff, who rejects this tradition and traces the poem to a prose hygienic epistle supposed to have been written by Aristotle for the benefit of his pupil Alexander the Great, and translated into Latin at the beginning of the twelfth century by a baptized Jew, John of Toledo. Dr. Packard admits that the authorship is doubtful, but appears to accept Croke's opinion that it was written by John of Milan, who is supposed to have been the head of the faculty of the Salerno school at the time. In this connexion it may be mentioned that in his scholarly history of this poem in the first Finlayson memorial lecture (1908) Sir Norman Moore came to the conclusion that the author is unknown. Dr. Packard's interesting sketch of Sir John Harington, who in addition to being one of the most characteristic of the Elizabethan courtiers, invented and described the modern water-closet, in "A new Discourse of a stale subject called the Metamorphosis of Ajax" (London, 1596), recalls Dr. J. G. Adams's attractive essay on this many-sided Cambridge graduate.

The poem is a handbook of domestic medicine; it was much in request, and, as was so common in the days before printed books, became much altered in the course of many copyings, successive scribes adding to it at their discretion; thus the early copy commented on by Arnold of Villa Nova contained about 363 lines, but subsequently it became expanded to over a thousand lines. It provides advice on diet, personal hygiene, and remedies, and ends on this cheerful note:

And ye our Physicke rules that freely read,
God grant that Physicke you may neuer need.

Like other publications from P. B. Hoeber, this volume is well printed and successfully illustrated.

NOTES ON BOOKS.

A FIFTH edition has just been published of Dr. J. RYLAND WHITAKER's book on the anatomy of the central nervous system.⁷ Dr. Whitaker is well known to many generations of Edinburgh students and Fellowship candidates as a singularly gifted teacher of anatomy, with a rare talent for clarity of exposition of the most intricate subject. This faculty is reflected in the present volume, the popularity of which is shown by the number of editions published, although it was once out of print for some years. The book is not long, but it is very complete; any increase in length over that of previous editions is due to rewriting with the object of rendering obscure passages easier to understand. The brief summaries and tables are an aid to quick and easy reference, and the excellent illustrations and diagrams fulfil their purpose of increasing lucidity where necessary. Dr. Whitaker talks of growing old, and if ever he does retire (though that seems impossible to old Edinburgh students) this book of his, filling a place peculiarly its own, will certainly keep his memory green.

Dr. A. S. GIBB, of Mostapha Supérieure, Algiers, has published, under the title *From Choul to St. Luce*, a new edition (the tenth) of his notes on Algiers and Algeria as a winter resort, which he first published some years ago. It is not exactly a guide-book but an impressionist sketch.

⁶ *The School of Salerno. Regimen Sanitatis Salernitanum.* The English version by Sir John Harington; History of the School of Salerno, by Francis R. Packard, M.D.; and a note on the Pre-History of the *Regimen Sanitatis*, by Fielding H. Garrison, M.D. New York: Paul B. Hoeber. 1920. (Demy 8vo, pp. 214, illustrated. 3.75 dollars.)

⁷ *Anatomy of the Brain and Spinal Cord.* By J. Ryland Whitaker, M.B., F.R.C.P. Fifth edition. Edinburgh: E. and S. Livingstone, 1921. Post-8vo, pp. 262, 105 illustrations. 12s. 6d. net.)

well illustrated by photographs. In addition to Algiers itself and Hammam-R'irba, there are short notes on many more distant places to which agreeable excursions can be made. The book appears to be issued for private circulation, as no publisher is mentioned.

THE anonymous author of *Memories and Musings of a Hospital Surgeon*⁸ has spent nearly fifty years in hospitals—as a student in London, as a house-surgeon, as an operating and consultant surgeon, and as a hospital governor. He is therefore well qualified to discourse to the layman of hospitals past and present, of patients and children, of operations and treatment in general, of medical education and the future of hospitals. He has little that is new or original to say, but in a manner of amiable rotundity—a compound fracture is described as having “an open wound leading down to the broken bone, thus exposing it to the deleterious influences of external agents”—he gives us, unconsciously, a self-portrait of a surgeon of the older generation. The author's allusions are to his own experiences, to the masters of his own craft, and to the Bible; he is a personal friend of all his poor hospital patients; his character is founded upon his early religious convictions.

We have received the thirty-sixth edition of *Sell's World's Press*,⁹ which forms an accurate and comprehensive directory to the periodicals published in this and other countries. The editor in his foreword records that, owing to the enormous increase in the cost of production, many old and valuable publications have now ceased to exist, while during the past year more than 500 have been forced to increase their selling price. The present edition of this useful directory, with its 35,000 entries, is introduced by a number of articles of interest to those concerned in newspaper production, by, among others, Lord Northcliffe, Mr. Robert Donald, and Mr. H. W. Massingham.

⁸ *Memories and Musings of a Hospital Surgeon*. Glasgow: Maclehose, Jackson, and Co.; London: Macmillan and Co., Ltd. 1920. (Cr. 8vo, pp. 198, 7s. 6d. net.)
⁹ *Sell's World's Press*. Founded by Henry Sell. Thirty-sixth edition. Edited by E. T. Brown. London: Sells, Ltd. 1921. (Roy. 8vo, pp. 158; illustrated.)

APPLIANCES AND PREPARATIONS.

An Outfit for Immediate Treatment of Cases of Poisoning.

DR. C. A. STIDSTON (Wolverhampton) writes: An examination of the reports of the Registrar-General for England and Wales alone, for the years 1901-1918 inclusive, reveals the fact that during those eighteen years more than ten thousand deaths have occurred from poisoning, caused by accident, negligence, suicide, or murder. Nearly eight thousand five hundred of these deaths were suicidal. There are no means of estimating how many additional cases of poisoning occurred with recovery, but institutional and private practice justify the assumption that the number of cases that recover greatly exceeds the number of cases that prove fatal. Hence it appears that poisoning is a serious cause of death and illness, and its treatment at the earliest moment is a matter of importance.

Whilst the poisons chiefly taken are commonly known and easily accessible—such as carbolic acid, which caused 1,740 of the deaths quoted above; oxalic acid, which caused 1,439; hydrochloric acid, which caused 1,249; and opium derivatives, which caused 1,062—the following list (compiled from the reports) shows how extensive and varied are the possible sources of fatal or non-fatal poisoning:

Acetic acid; acetanilide; aconite plant; ammonia; aniline; antimony chloride; aspirin; atropine sulphate; A.B.C. liniment; ammoniated tincture of guaiaicum.
Barium chloride; belladonna; berries of laurustinus, deadly nightshade, ivy, laburnum.
Chloroform; chloroform; cocaine; coal tar; chromic acid; camphor; copper sulphate; chloride of lime; creosote; camphorated oil; caustic soda and potash; chloral hydrate; cresolene; carbolic acid; coal-tar naphtha; colza oil.
Daisies; digitalis; delphinium; dry daisies; Dutch drops.
Ether; eserine; eucalyptus oil; ergot.
Formalin; fluoric acid; formaldehyde.
Gaultheria oil.
Hartshorn oil; hyoscyamus.
Iodine; insectic. de.
Lysol.
Methylated spirits.
Nepenthe; nicotine; nitre; nitric acid.
Paraffin; paregoric; potassium chlorate, oxalate, permanganate, bromide, binoxalate, and chloride; petrol; phosphorus, paraldehyde.
Quinine.
Red precipitate; rhubarb leaves.
Sodium nitrate; salts of lemon; sulphonal; sheep foot rot dressing; soldering fluid; soap liniment; sulphuric acid; solanin; sal volatile.

Thymo-cresol; tartar emetic; trional; toxal.
Veronal; vermin destroyer.
Wood spirit; weed-killer.
Yew berries.
Zinc sulphate.

A summons to a case of poisoning is often a cause of bewilderment and dismay to a medical man. He hurriedly tosses a few chance emetics and antidotes into a bag, often owing to the scanty information offered by the messenger, omitting the items essential for dealing with the particular case. The stomach tube is not to be found; the hypodermic case is, perhaps, at the bottom of the midwifery bag, the book on toxicology is lost. To complete the outfit a futile attempt is made to reach an inaccessible chemist, and a delayed arrival finds the patient beyond treatment or only fit for transfer to a distant institution, there to succumb and await the coroner's court. Clearly it is advisable that an outfit containing emetics, stimulants, antidotes, and apparatus for emptying the stomach should be in the possession of every medical practitioner and should be available in the first-aid rooms of works, in police stations, and in the casualty departments of hospitals. This need having been recently and painfully brought home to me by personal experience, I have designed an outfit to prevent delay in future cases. It consists of a small, easily portable, japanned tin case, which opens portmanteau-wise and which, to avoid the tragedy of the lost key, possesses no lock. The contents of the case are all displayed when it is opened, and consist of the following:

Stomach tube and rubber funnel; a smaller tube for children.
Gag to open mouth; gag to pass tube through.
Tongue forceps.
Record hypodermic syringe.
Murrell's book, *What to do in Cases of Poisoning*.
Hypodermic tablets: Apomorphine hydrochlorate, strychnine nitrate, atropine sulphate, morphine tartrate, aconitine, pilocarpin nitrate, digitalin.
Capsules of amyl nitrite.
Pituitrin.
The following in two or four ounce glass-stoppered bottles—with dosage on labels:

Zinc sulphate; sodium chloride; mustard; brandy; coffee; tea; sal volatile; wood charcoal; permanganate of potash; dialysed iron syrup of chloral; magnesia; potassium bromide; chloroform sodium carbonate; sodium sulphate; magnesium sulphate vinegar; tincture of opium; olive oil; castor oil.

Spare bottles.

This outfit has been made and furnished by Messrs. Philip Harris, chemists, of Birmingham.

Nasal "Aseptoids."

WE have received from Messrs. Oppenheimer, Son and Company, Ltd., a sample of "aseptoids" nasal compound, prepared from a formula by the late Dr. Macnaughton Jones. The ingredients are moulded without compression into square-shaped tablets, readily soluble in warm water for use as a gargle or nasal douche; their uncommon shape and appearance make it unlikely that they would be mistaken for medicinal tablets and swallowed.

THE DIARY OF CROSSE OF NORWICH.

THE diary of Bob Sawyer would have been interesting reading. *Mutatis mutandis*, it would have run somewhat on the lines of the well known "Diary of a Resurrectionist," and would have been, in part at least, a record of drinking bouts with Mr. Allen and the Pickwickians. It would not, however, have been a fair representation of the life of medical students then. A hundred years ago there were at least three types of medical students—the Sawyers and Allens, the hard-worked and ill-fed apprentices, and the select class who paid premiums to teachers of repute, and may be said to have been young men with a future. To the last-mentioned category belonged John Greene Crosse, afterwards well known, and now still quoted as "Crosse of Norwich."

Born in 1790 of yeoman parentage in Suffolk, Crosse was well educated by a hard-working father, and never really sank below the line of self-respect and well-being. It was not till he had reached the age of 29 that he, then in practice in Norwich, procured a book with a view "of filling a few of its pages from time to time with memoirs." This was in continuation of his boyish diaries. As became an accomplished practitioner, he now aimed during his remaining life at amassing materials for a classic work on surgery, and "should aspire to no higher pitch of posthumous fame than to have a few memoirs of my life prefixed to my work, in order to show how industrious habits are their own reward, and how obscurity of birth

and disadvantages in education are overcome by steady and honest perseverance."

After this formidably meritorious opening, which suggests a reflection by Herbert Spencer, we meet with this quaint vignette: "I can well remember, when a child put out to nurse in a humble cottage near my father's, that the old lady, of ominous name, *Goody Death*, during a thunderstorm, used to read her Bible in great fear, and offer prayers to appease a justly offended God, humble and contrite for her manifold sins; and I by her side joined her as far as my age would allow in fear and prayer." He lived to find out the secret of summer storms as purifiers of the air and fertilizers of the soil, and to take the then optimistic view of natural phenomena. He was not sent to boarding-school, and for this reason is of opinion that he contracted lifelong unsocial habits. Reading, writing, and arithmetic he learned from a horrifying master. "His stern brow, raucous voice, and long cane, are now lively depicted to my mind." When Mr. Crosse was in his twelfth year, "a Welch gentleman making some mistake at college (not implicating his good character, an *informality* I should call it) found it well to rusticate." Indeed, Mr. "Jones of Jesus," as we will call him, married while still an undergraduate, and was compelled to open a school for a living. The little boy was one of his first pupils. Mr. Jones was "a plodding working man," and an increasing family goaded him into being an excellent teacher. To him Crosse owed a knowledge of Latin and Greek, and laid the foundation of remarkable linguistic attainments under his mild rule. At the age of 15, on his way home from school he tried "a feat in jumping" and broke his leg. "The respectable village surgeon attended me: he was one of the old school; of fine, soft, soothing manners, clean dressed, with powdered head; rode slowly a very well-looking horse; in short, he was a gentleman, and commanded the respect of everyone when he entered the house; he was also a skilful and kind surgeon. What wonder that the idea should be awakened in my mind to be of the medical profession! to be as great a man as he—the Village Doctor! to whom everyone bowed, and who could relieve pain and cure injuries so quickly and skilfully. I had conceived an object of ambition, and the idea never deserted me. I was in a month upon my crutches and soon recovered; a surgical case fixed my future destinies."

For a time, however, after finishing his study of Latin, Greek, French, and Euclid, he was in a lawyer's office and did not like his work. He attended bankruptcy meetings and feasted "at midnight at the expense of the already distracted creditors. Those were good times for lawyers. A learned chancellor, whom I met on one such occasion, I will remember complimenting me on my quickness in counting money; but all would not do, my mind was pre-possessed—I quitted the law to follow my inclination; I made my own choice; it was a pledge to success. The surgeon who cured my leg agreed to take me as his first and only pupil, and I was accordingly articled in due form for five years."

He took up his residence with Mr. Bayly of Stowmarket, bought a book, and wrote on the title-page: "Hic liber a Johanne G. Crosse fiebat, Augusti 8vo, Anno Domini 1806. On Wednesday, April 3rd, 1805, I broke my leg."

The first entry in the diary runs thus: "Die lunae Augusti 18, 1806. Came to Mr. Bayly's. Rolled up pills, etc." There follow accounts of daily routine. He goes to bed at ten or eleven o'clock, rises from six to eight. On August 27th he "did up a man's leg before Mr. Bayly was up, for the first time. Made a pledget and put it into a boy's ankle. Made 38 pills in the afternoon." His first surgical operation was the drawing of a tooth. Later he went with Mr. Bayly to see Martin Cheney's leg, which was hollow. "Mr. B. ran a silver pin in three inches, and a matter came out."

This first volume ends on January 31st, 1809, and he has then been to many balls and music parties and has lived a civilized life. There is a charming Miss Bayly, who afterwards becomes his wife. Volume II is much more profound, and we find him a deep and careful student of general literature. He reads a Life of Malesherbes, the advocate and friend of Louis XVI. "His wisdom I admire, his piety, his liberality, his courage; he was the foe of tyranny, the encourager of learning, the defender of the oppressed. . . . I will endeavour to imitate so virtuous a character, and I pray for the

assistance of Almighty God." He reads Corneille and religious books, and plays a good deal of whist. "I would never trifle so much as to play were it not to please; he has obtained a great point in the art of pleasing, who has learnt to trifle well." England being then in the throes of war with Napoleon, he reflects sagely on the proper conduct to observe during times of stress. "It behoves us at all times to keep from every wicked thing, but more especially in time of war and danger." The war is responsible for strange social reverses. "A woman came begging here to-day who was, or had been, mistress of French and music; she says she had a good education and had lived in high life, but a series of misfortunes reduced her to the necessity of begging her bread in her old age. I heard her play on the piano, and though long out of practice and her fingers stiffened by labour and fatigue she showed some knowledge and execution. French she could speak as fluently as English."

Crosse wrote two more volumes of reflections and daily occurrences, the fourth glancing at his early career as a student at St. George's in 1811-15. He became the pupil, and later the lifelong friend, of Sir Charles Bell. In 1812 he studied under him and under Bradie, Brand, Clarke, and Home, and remarks in his journal, "Very industrious all this winter, sitting up constantly till past two a.m." Throughout life he was an ardent student, a man of an intensely earnest character, yet vivacious and joyous in spirit. He became famous as a lithotomist in a district where calculous disease was endemic. As an operator he had few rivals, and his students delighted in his teaching. He died worn out by the multiplicity of his activities at the age of 60. He had burnt the candle at both ends for many years, during which he took notes of all important cases in his public and private practice, wrote and read professional works voluminously, lectured, operated, rode long distances to attend *post-mortem* examinations, and at night, after an exhausting day, would, after listening to a little music, spend many hours in literary pursuits, "trusting to a change of occupation for relief and amusement" rather than to the rest that was so necessary for him. He set a bad if high example, but one that only the few were likely to follow.

Perhaps his best known work is his Jackson Prize Essay, "On the Formation, Constituents, and Extraction of the Urinary Calculus." For this he received the diploma of M.D. from the University of Heidelberg, and the year after was elected F.R.S. The original MS. of this important essay, together with his drawings, are in the library of the Royal College of Surgeons. The work was published in 1841; it had three appendices, one of which contains an exhaustive bibliography of calcular lithotomy. This alone bears lasting witness to the vast extent of his reading. It contains his portrait, showing a nervous, over-intellectual face. (Victor G. Bask.)

THE CINEMATOGRAPIH.

The multiplication of "Picture Palaces" must be patent to everyone, but few who have made this observation will know what an immense industry there is behind these small and gaily decorated places of entertainment. The production of a film is a very great business. Thousands of actors and actresses are engaged in the work of production in this and other countries, and an examination of a Stock Exchange list will show what a large amount of capital is employed in these ventures, not taking into account the resources of private firms. Until recently little has been heard of the studio side of the industry, excepting an occasional newspaper paragraph that such and such a firm had produced some wonderful film of many thousand feet necessitating the engagement of some hundreds of actors and the expenditure of thousands of pounds. The statements seem like fairy tales, but they can well be believed when the inside of a good sized studio is seen. Recently other interests have been added from the medical point of view. Dr. Chappé, writing in the *Annales d'Ophtalmologie* in July, 1920, under the title of "Conjunctivite chez les Artistes du Cinéma," stated that cases had been observed in which exposure to the brilliant artificial illumination of the studios had produced attacks of pain and conjunctivitis of transient duration. An earlier account in a trade journal stated that several members of a film company were affected by semi-blindness,

British Medical Journal.

SATURDAY, FEBRUARY 12TH, 1921.

STUDIES OF INFECTED WOUNDS.

In a special report to the Medical Research Council,* Captain S. R. Douglas, Mr. A. Fleming, and Dr. L. Colebrook describe a series of researches made by them on infected wounds of soldiers under treatment at St. Mary's Hospital during the great war. These studies were in close relation to those of Sir A. E. Wright, who had been actively investigating wound infections at No. 13 General Hospital, Boulogne, since an early stage of the war: the patients investigated at St. Mary's having been selected and forwarded from No. 13 General Hospital for that purpose.

This report is divided into three parts. Part 1 deals with the nature of the cases treated, the methods of treatment employed, and certain conclusions arrived at. Special forms of treatment are referred to, such as the method of skin grafting employed by Steele as long ago as 1870, now revived and modified apparently with great success. Another interesting observation is the effect of spraying a wound with certain aniline dyes such as malachite green or brilliant green in order to promote the growth of epithelium. A particularly successful and useful device employed by the present investigators was adopted by them for the purpose of alleviating the pain occasioned by dressing wounds. The principle, briefly, is to place next to the raw surface of the wound some freely perforated but non-absorbent material. Celluloid was at first employed, but later a still better material was evolved known as "perforated parax protective."

The second portion of the report is devoted to a description of the pathogenic bacteria found in the wounds and to a full account of the characters of these organisms. The point is made in the first place that in case of these war wounds the primary infection is made up largely of faecal bacteria. The micro-organism, however, of chief importance in war wounds is *Streptococcus pyogenes*, which "was present in practically every septic wound and was able to resist the bactericidal action of the body fluids and cells to a much greater degree than any of the other bacteria present. It was this coccus that was responsible for nearly every complication that occurred in the cases during their stay in the wards of the Inoculation Department, the commonest of these being erysipelas, the formation and persistence of sinuses, and also such constitutional symptoms as fever."

A study was made of the cultural and fermentative characters of 160 strains of streptococci present in 30 wounds taken at random. *S. pyogenes* was isolated on one occasion at least from 28 out of the 30 cases, and in 15 of them it was the only streptococcus found.

On analysis the 160 strains of streptococcus gave the following results: *S. pyogenes* 118 specimens, *S. salivarius* 10, *S. faecalis* 8, *S. equinus* 5, and *S. anginosus* 2; 17 of these streptococci were unclassified. A special interest attaches to the serological investigation which was made of specimens of *S. pyogenes*. First it was found that all of 24 strains of this streptococcus were agglutinated to approximately the same titre as the particular strain used in preparing the serum. Next it was demonstrated that the mannite-fermenting strain of *S. pyogenes* is of the same serological type as the ordinary strain of this coccus that does not ferment mannite. This identity of the strains of *S. pyogenes* occurring in wounds was established not only by agglutination, but also by absorption tests.

In addition to these studies of streptococci, specimens of diphtheroid bacilli, anaerobes, and *B. proteus* occurring in the wounds were carefully studied and their characters recorded. The frequency of diphtheroid bacilli in wounds is well known, and while the majority of them appear to be of minor significance, there is no doubt that occasionally a true Klebs-Loeffler bacillus is to be found. The present investigators suggest that some of the diphtheroid bacilli present in wounds may be specimens of the acne bacillus. Sixty-one strains of diphtheroid bacilli were investigated very fully and their characters defined. The vast majority of these strains were non-pathogenic to the guinea-pig: from four wounds, however, a bacillus was isolated that could not be distinguished from *B. diphtheriae* in pathogenic or other respects. The patients from whom these cultures of virulent diphtheria bacilli were isolated showed no clinical signs of such infection, no formation of membrane, and no constitutional disturbance. The work done on the anaerobic bacilli is a valuable supplement to that of the Anaerobic Committee, and the St. Mary's Hospital observers describe and name several new forms of these bacteria which they isolated from wounds.

The third part of this report contains a series of experimental studies of the interaction between the wounded tissues of the patient and the infecting bacteria in the presence of various antiseptics. It will hardly be disputed that the valuable and sustained researches of Wright and his colleagues at St. Mary's during the years that preceded the war, on the finer processes of immunity and phagocytosis, fitted them better, perhaps, than any other group of workers in Europe or elsewhere to undertake this particular line of war research. For this reason the present report of these investigators should be read, if possible, by all of those interested in the healing of septic wounds. That some progress has been made with regard to our understanding of the healing process is clear, but that anything approaching finality has yet been reached is open to doubt. Antiseptics of all the kinds investigated would appear to be of little or no value as such when tested *in vivo* by the methods described in the report. We could wish that at a future date the Medical Research Council would issue in a compact form an account of the completed work of Sir Almroth Wright and his colleagues on the biology of infected wounds. If to this volume there were to be prefixed a summary of the state of knowledge on this subject before the war began, it would be of great help both in raising appreciation of the ingenious and highly adaptable technique which is such an outstanding feature of the St. Mary's school, and also in facilitating assessment of the progress actually made towards solution of a problem of cardinal importance to the surgeon in peace as in war

* Medical Research Council. Special Report No. 57. Studies in Wound Infections. By Captain S. R. Douglas, M.R.C.S., A. Fleming, F.R.C.S., and L. Colebrook, M.B. H.M. Stationery Office. 1920. 4s. 6d. net.

THE MILK SUPPLY.

If beer and other alcoholic beverages were produced under the same insanitary and unsavoury conditions as those which are associated with the production of a large quantity of the milk consumed in this country the task of those who are anxious to persuade the nation to "go dry" would be very much simplified. The reports of medical officers of health and other officials in pre-war days made us familiar with dark and unventilated cowsheds, the walls and floors of which were in a foul state, with fold-yards so choked with manure that the cows had to plunge through it in order to enter the sheds to be milked, their udders trailing in the filth, and we were told of dairy farms with inadequate water supplies, resulting in uncleanly utensils and unwashed hands of milkers.

The vigorous propaganda that has been carried on for the last ten or fifteen years has left the dairy farmer no excuse for continuing his lax practices. It has had a considerable effect on the more public spirited owners and farmers: scattered up and down the country to-day are many dairy farms which may at least serve as models. Nevertheless, the position generally is that stated by Lieut.-Colonel Brittlebank, of the Public Health Department of the Manchester Corporation, in his report to Dr. James Niven, the medical officer of health, for 1919: "My impression," he says, "on visiting some of the country farms was that, so far as cleanliness was concerned, we were very much in the same position as we were fifteen years ago. The cowsheds were dirty and the cows were in a general state of filth." For years past public health reformers have been crying out for amendments in obvious directions, but to very little purpose, though in April last the Ministry of Agriculture and Fisheries was constrained to issue a Memorandum in which it was stated that there was an abundance of evidence in support of the contention that the milk supply on reaching the large consuming centres was too highly charged with dirt and bacterial life.

The trade of a dairyman and cowkeeper is regulated by the Dairies, Cowsheds, and Milkshops Order, 1885, and the amending Orders of 1886 and 1899, and Regulations which may be made under the provisions of those Orders. The authorities charged with their administration are the urban and rural district councils, the members of which, as regards the rural councils, are largely drawn from the dairy farmers themselves, so that it can hardly be expected they should display much enthusiasm in enforcing regulations which necessitate any very considerable outlay. Indeed, many rural authorities refuse even to make regulations, and the supervision carried out is either absent or wholly inadequate.

It is a strange commentary upon the manner in which our great central departments are conducted that whereas the Ministry of Health and the Ministry of Agriculture and Fisheries appear to have failed in effecting reforms there should have come to their assistance a subcommittee appointed under Profiteering Acts. In January of 1920 this subcommittee was deputed to "investigate the question of trusts, combines, agreements, and other conditions affecting prices in connexion with the milk trade, including milk products so far as they relate to the consumer in this country." This Committee has just reported, and it is satisfactory to find it stating that recent large combinations of milk distributors have not dealt unfairly with either the producer or consumer and that large economies have been effected by the combinations. The most important conclusion,

however, is "that there is still ample room for improvement in the methods of dealing with milk at all stages, both from an economical point of view and also having regard to the health of the nation. We recommend that all milk should be delivered in bottles. In order that this may be accomplished, we consider that either some form of combination amongst the distributors is inevitable, or municipalities should be empowered to undertake the distribution."

Hitherto attempts at municipalizing milk supplies have not met with success. Whether such an enterprise would tend to lower the price of the commodity is more than doubtful, but it might be expected that the conditions of production would be improved as compared with the general farming standard as it exists to-day. The unsatisfactory administration of the laws regulating the supply of milk generally applies with equal force when the question of the distribution of milk from tuberculous cattle is considered. The Dairies, Cowsheds, and Milkshops Orders, which are operative throughout England and Wales, prohibit the sale or use for human food of milk from a cow which is certified by a veterinary surgeon to be suffering from tuberculous disease of the udder. What have come to be known as the Manchester Milk Clauses because they were contained in the Manchester General Powers Act, 1899, have been incorporated in several other private Acts—for example, in the Liverpool Corporation Act, 1900. These clauses prohibit, under a penalty, the sale of milk from a cow known to be suffering from tuberculosis of the udder. They also enable supplies of milk to be followed up to the dairy farm itself wherever it may be situated, and gives power, if found necessary, to prohibit the supply of milk from the farm. In Manchester during 1919, in 20 out of 351 samples of mixed milk examined tubercle bacilli were found. During the consequent visits of inspection 13 cows were definitely proved by bacteriological examination to be suffering from tuberculosis of the udder. Ten of these cows were slaughtered under direct supervision, and in all cases the carcasses were found to be unfit for human consumption and were condemned.

CREMATION IN ENGLAND.

Among the enlightened classes opinion is steadily growing in favour of cremation; but among the community at large sentiment and prejudice still stand in the way of a general resort to this means of disposal of the dead. It is possible, however, that the acute shortage of land accommodation—for the dead as well as for the living—in the neighbourhood of all populous centres may bring the claims of cremation into greater prominence, and so induce public authorities to increase the facilities. It might happen that with a larger number of crematoria in various parts of the kingdom demand would keep pace with supply, for the cost of transporting a body by rail is at present prohibitive to persons of ordinary means, and this is a factor favouring earth burial, at any rate in country districts. Extracts sent us in advance from the report of the Cremation Society of England indicate that during the past year some 1,800 cremations were carried out in this country, and of these nearly one-half took place at Golders Green. In no instance, it is stated, was there any reason to doubt the cause or the fact of death, so efficient is the working of the precautions laid down by the Act passed by Parliament for this purpose. For nearly half a century the Cremation Society has carried on its valuable work. It has striven to overcome opposition and prejudice by practically demonstrating its objects, unaided by the State, and imposing no burden upon local rates, but mainly

from funds provided in the first instance by a few public spirited supporters. Since the opening of the Woking crematorium in 1885 nearly 23,500 bodies have been cremated in Great Britain. In addition to the crematoria at Golders Green, Woking and Norwood, there are others in Manchester, Glasgow, Birmingham, Liverpool, Sheffield, Leicester, Hull, Leeds, Bradford, Ilford and Darlington. The Cremation Society has this year inaugurated a scheme of free registration, enabling those who prefer cremation to record during lifetime their wish for this method of disposal at death. Information may be obtained from the Secretary, 52, New Cavendish Street, W. By enlisting the co-operation of a wider circle of living adherents the Society hopes to secure in time the abolition of earth burial, with its danger to health and its waste of money, labour and land. In the United States progress has been more satisfactory. According to the new *Hazell Annual and Almanack* there were in 1919 in the United States 79 crematoria. In that year 12,372 bodies were cremated, which was more than in 1916 but very much less than in 1918, when for some reason all previous records were far surpassed.

VITAMINES.

THE current number of the *Biochemical Journal* contains a number of papers dealing with conditions which determine the presence of vitamins and bring about their diminution or destruction in the course of the preparation of food for the table. Professor Gowland Hopkins points out that a knowledge of the conditions affecting the stability of vitamins is not only of practical importance in connexion with the commercial and domestic treatment of food, but would also be of value in guiding attempts to isolate them, and in limiting hypotheses as to their nature. Many investigations made during recent years of the fat-soluble A vitamins have shown that animal fats, with the exception of lard, are decidedly richer in it than vegetable oils. Conflicting statements have been made as to the resistance of this vitamin to heat. Some experimenters have concluded that it is thus readily destroyed, but in his paper opening the discussion in the Section of Medicine at the annual meeting at Cambridge,¹ Professor Hopkins confirmed the statement of Osborne and Mendel that it is resistant to heat. The explanation of the difference of opinion, he states, is that while the vitamin in butter is not diminished by exposure to a temperature of 120° C. for four hours, it is within the same period greatly diminished and in twelve hours altogether destroyed if the butter is thoroughly aerated during the heating. Drummond and Coward now give an account of an experiment which led them to the same conclusion. The probability is that the destruction of the vitamin is due to oxidation, and this appears to be confirmed by Hopkins's observation that vitamin A disappears from butter spread in thin layers and exposed to air at temperatures of 15° to 25° C.; Drummond and Coward found that the loss was considerable at 37° C. Lard, as has been said, has been looked upon as an exception to the rule that animal fats contain vitamin A. This seems to be due not to the complete absence of vitamin from the body fat in pigs, but to two circumstances—first, that the diet usually employed to fatten pigs is not rich in vitamin A, and, secondly, that in the process of manufacturing lard, which involves raising the fat to a temperature of 102° C., much of any vitamin A there may be must be destroyed. Drummond, Golding, Zilva, and Coward relate an instructive experiment made on a litter of Berkshire pigs. For the present purpose it will be sufficient to say that it demonstrated storage of vitamin A in the body fat of pigs receiving a diet containing considerable amounts of vitamin A, yielded, in this instance, by fresh grass. The fat of the pig, probably because the animal fattens quickly, contains less vitamin A than that of other animals, and when a young pig is fed

on a diet very deficient in vitamin A, such as toppings and whey, it may not be possible to detect that vitamin in the body fat. An interesting point as to the value of milk in maintaining growth is discussed in another article by Professor Hopkins; in one of his earlier papers on accessory food factors (1912) he had described the startlingly favourable effect of adding minute amounts of milk to synthetic dietaries incapable by themselves of maintaining the growth of rats. Experiments made later by Drummond and by Osborne and Mendel failed to yield the same results, and those made by Hopkins himself in the winter of 1919 were disappointing, for though the animals who received the small quantity of milk kept in better health and lived longer than those on a synthetic diet alone, they grew very slowly and their death rate was high. In another set of experiments which he began in April and May the contrast between animals receiving the small quantities of milk and the others who received none was as marked as in his earlier experiments. The difference in the diet of cows in summer and winter suggests itself as a probable explanation, and McCarrison has in our columns laid stress on this point. Osborne and Mendel, however, were unable to show that this factor influenced their results, and an experiment Professor Hopkins made with goats gave no support to the theory. There is seasonal variation in the growth of energy of rats, but Professor Hopkins doubts whether this would account for the experimental difference, and regards the question as still open.

HOME SERVICE AMBULANCES.

THE Home Service Ambulance Committee of the Joint Council of the British Red Cross Society and the Order of St. John has prepared a report of its work down to the end of last year. The object with which it was formed, shortly after the Armistice, was to establish a motor ambulance service in England, Wales, and Ireland, which would afford means for rapidly and easily conveying the sick and disabled, especially those in rural areas, to a hospital or other institution for treatment. Ambulances which had been in use in France during the war were overhauled and the most suitable put into a state of repair. In April, 1919, a circular letter was addressed to county directors inviting them to apply for such number of motor ambulances on loan as would meet the needs of the county, the suggestion being that the ambulance garages should be approximately thirty miles apart, so that there would always be one not more than fifteen miles from a patient. The distribution of ambulances began on May 24th, 1919, and by the end of that year 238 had been stationed; by the end of last year the number had been increased to 273. During the first twelve months of the Committee's work the total number of cases carried in the ambulances was only 5,227; three months later this was increased to 22,409, and at the end of 1920 the total number carried had risen to 38,260. Poor Law cases are conveyed at the cost of the local authority, but there are many patients whose circumstances are such that the charge for the use of the ambulance must be partly or entirely remitted. Nevertheless, in many counties the receipts have been sufficient to cover the cost of the service. The home ambulance service has become an established institution. The military ambulances originally issued are being replaced by a lighter type. The light ambulances have room for two stretchers only instead of four, but in practice this has not been found disadvantageous. The running cost of the lighter ambulance is approximately 50 per cent. lower than that of the heavy type. It has not yet been possible to supply all the ambulances the Committee has agreed to allot, but arrears are being rapidly overtaken. The number in each county of course varies with the area and with the character of the population. Durham and Essex have twelve at work; Kent, which asked for twenty, has been allotted twelve, and has ten in use. The West

¹ BRITISH MEDICAL JOURNAL, July 31st, 1920, p. 147.

Riding of Yorkshire is to have twelve, and has now eleven at work; the agricultural East Riding asked for five, and has three at work. The Committee is satisfied with the success achieved during the last twelve months. It is recognized that the variation in the work done in different counties is not always in due proportion to the real needs, but it is hoped that as the scheme becomes better known the use of the ambulances will grow.

MALARIAL PREVENTION.

DR. C. F. LASSALLE'S report¹ on an anopheles survey of the colony of Trinidad and Tobago furnishes interesting reading. Carried out with great care and accuracy, it should form a standard for work of this nature. It deals fully with all the known methods for destroying and keeping down anopheles, and it points out that many of the recommendations can be carried out efficiently by a small sanitary gang working under the direction of the sanitary inspector of the district concerned. In his conclusions he quotes a passage from Hoffman which is worthy of note: "Rural sanitation and malaria prevention are practically synonymous or equivalent terms and the one, broadly speaking, cannot be achieved without the other. Malaria prevention, to be permanently successful, however, requires the most complete co-ordination of governmental, corporate, and private functions and efforts to the same extent to which this has been the case in Panama, where practically the whole population has been brought under most perfect sanitary control." People nowadays look at the subject of malaria prevention in a much more common-sense manner than they used to, and of course no scientist dreams of exterminating the whole of the mosquitos of an island or other area, though this is what the laity still imagine. Dr. Lassalle refers to this in his report and shows how such ideas retard progress and make the lot of the sanitarian a hard one. Still the new ideas are gradually creeping in, even outside the entomological and medical worlds, and the progress which has already been made should soon be multiplied indefinitely. Those interested in the subject should certainly read Dr. Lassalle's report.

THE TEACHING OF THE MECHANISM OF LABOUR.

THERE are certain subjects in the medical curriculum that are traditionally regarded as stumbling-blocks to the student, and expected to prove such to each generation in succession. How far this expectation on the part of the teacher is father to realization on the part of the taught may be a matter for speculation, but the general effect is detrimental. Amongst such subjects the mechanism of labour has always held a place, and many are the students who would class it along with the better known *pons asinorum* of earlier days. Any plan for the simplification of the teaching of mechanisms without sacrificing scientific accuracy should therefore be welcomed by all teachers, and this is the reason why we would draw attention to an article in the *Indian Medical Gazette* of September, 1920. The writer is Lieut.-Colonel A. Buchanan, I.M.S., lately Superintendent of the Robertson Medical School, Nagpur, and he writes not as an obstetrician, but as one whose main interest is to simplify as far as possible the studies of the students under his educational guardianship. Possibly it is just because he is not an obstetrician that there is a certain freshness of outlook in Colonel Buchanan's method of approaching the subject. At the same time the novelty is essentially in the method of demonstration; the cause of the constituent movements of the head mechanism is not explained. In our view it would be a mistake to regard the author's work as a valid argument for recasting Naegele's teaching as to presentations and positions.

Colonel Buchanan points out that the foetal head, looked at from the side, resembles a semicircle with the occipito-mental diameter as its base. The centre of this half-circle, a point which he calls *a*, nearly corresponds to the cranio-vertebral junction, and may therefore be regarded as the pivot round which the head "circulates" in flexion or extension. Similarly, a vertical mesial section of the pelvis may be likened to a quadrant of a circle with its centre, *p*, at or near the subpubic angle. He uses models constructed on these lines to represent the head and the pelvis, and to the centre of the base of the head he attaches a wedge to represent the trunk. The problem is now to pass the semicircle through the quadrant, and the writer shows how an easy passage is only possible when the centre of the base of the head is close to the centre of the quadrant of the pelvis. When this is the case, a radius of the head passes through the pelvis instead of a diameter. In parturition the pivotal point of the base of the head is close to the centre of the pelvic quadrant in occipito-anterior vertex cases where flexion is adequate, in mento-anterior face cases where extension is adequate, and in the case of the after-coming head where the back of the neck is under the symphysis. In all of these the semicircle of the head circulates round the symphysis easily, just as a bicycle wheel circulates within its mudguard, because the two are centred upon the same axle. Contrariwise, when the pivotal point of the base of the head is far distant from the centre of the pelvic quadrant there is difficulty in the passage of the head, as is instanced in persistent occipito-posterior cases and persistent mento-posteriors. The models, which we understand are to be had from the Medical Supply Association, Gray's Inn Road, are ingenious, and calculated to be helpful in making quite clear points which it is not easy to describe in writing with complete lucidity. In addition to the features mentioned, the models may be used to show the essential sameness of the objects of flexion in occipito-anterior vertex cases, and of extension in mento-anterior face cases, as well as how premature extension of the head is apt to lead to rupture of the perineum. Those who are interested in this most praiseworthy attempt to simplify a troublesome subject will do well to read the short original article in our contemporary.

DIABETES INSIPIDUS AND THE PITUITARY.

A STRIKING practical outcome of the great volume of physiological, pathological, and clinical work that has accumulated for many years in connexion with the pituitary is that after injections of pituitary extract the polyuria of diabetes insipidus of hypophyseal origin disappears for about twelve hours; by repeated injections of the extract the patients can thus be given a respite, particularly at night, from the otherwise constant disturbance involved by the polyuria. This therapeutic effect, first pointed out by Farini in 1913, and copiously illustrated in a paper read last year at New Orleans by Professor Lewellys Barker of Baltimore, has been thought to rival that of thyroid extract in myxoedema, but the effect is not only more transient but much more rapid in its onset; thus, an hour after the administration of 1 c.cm. of the extract of the posterior lobe it is impossible to distinguish the urine of a patient with diabetes insipidus from that of a normal person. It is difficult even now to explain satisfactorily the mechanism of this therapeutic success, for the physiological effect of extracts of the posterior lobe and *pars intermedia*, the cells of which are concerned with the excretion of water, has usually been found to be diuresis; and, conversely, as long ago as 1911, Professor Harvey Cushing pointed out the difficulty of harmonizing the diuresis that may accompany hypopituitarism with the *a priori* expectation that individuals with this glandular insufficiency would show a lowered urinary output. In a critical review of hypophysical polyuria, based on 117 cases, of which 5 are

¹ Report on Anopheles Survey of the Colony of Trinidad and Tobago. By C. F. Lassalle, M.D., D.P.H., Deputy Surgeon-General and Medical Inspector of Health. Trinidad; Printed at the Government Printing Office, Port of Spain. 1920.

original. Schulmann and Desoutter¹ have gone over the whole subject, and comparatively recently Drs. Kennaway and Mottram² have provided a valuable abstract of the literature. The predominance of males—64 per cent.—among the French observers' cases is thought to be possibly due to the influence of syphilis, and cases of cure after antiluetic treatment are given. The usually accepted pituitary origin of diabetes insipidus has been disputed by Camus and Ronssy on the grounds that they produced it by puncture of the base of the brain, near the corpora mammillaria, and that pituitary extract has not any specific curative action apart from the fall of blood pressure and vomiting induced by its sudden entry into the veins. This divergence of opinion is discussed in both the reviews, and Drs. Kennaway and Mottram suggest that the polyuria following experimental injury of the base of the brain is due to escape of pituitary secretion into the cerebral substance, there being some evidence that pituitary extract can produce both antidiuretic and diuretic effects from the presence of two substances. The antidiuretic effect of pituitary extract, thus shown in the treatment of diabetes insipidus, appears to be due to the direct action on the kidney and not to depend on diminished absorption of water from the intestines. In order to obtain this antidiuretic effect the drug should be given hypodermically, administration by the mouth being unsuccessful unless the fresh gland is given in large quantities, ten to twenty times that necessary in hypodermic injection. The French observers tabulate various clinical forms of pituitary polyuria, and in those associated with Fröhlich's adiposo-genital syndrome, Dercum's disease, and infantilism, both sets of clinical manifestations were relieved by pituitary injections; they draw a distinction between pituitary and other forms of polyuria, and state that in the former the renal permeability is normal, except for water, in regard to which it is exaggerated. Failure of response to pituitary medication may be due to the nature of the preparation, the anterior lobe of hypophysis being inert in this respect.

DIURNAL CHANGES IN THE SIZE OF RED BLOOD CELLS.

DR. CECIL PRICE-JONES, ten years ago, described in the pages of this JOURNAL³ his method of measuring the variations in diameter of the red blood cells by projecting the image of the microscopic field on to a table by the aid of a camera obscura, the apparatus being adjusted for a magnification of 1,000 diameters, so that the cells might be measured with a millimetre scale and expressed in terms of fractions of μ . He has now applied his method for the purpose of endeavouring to explain the considerable variation in the mean diameter of the red cells in the healthy person, adhering to one chosen method of preparing the blood films for the purpose of comparison, as it was found that alterations in the fixing and staining reagents produced changes in the mean diameters of the red cells. The result of his researches has been published in an interesting article in the December number of the quarterly *Journal of Pathology and Bacteriology*. That there is a diurnal variation in the diameters of red cells—namely, a gradual increase during the day and a diminution during sleep—appears from tables which show three sets of observations taken by Dr. Price-Jones during ordinary working days, the first film in the morning being taken immediately on waking. The variations are striking; they amount in some cases to as much as 0.6μ , suggesting that the red cells swell and shrink in association with bodily activity. For example, in one series a quick rise of 0.46μ between 8.20 and 9.20 a.m. was recorded after a short push-bicycle ride with a trailer. By experiment it was found that (a) violent

exercise—for example, the investigator ran as quickly as he could up and down six flights of steps three times, until he felt unable to run any more and was distressed in breathing—increased these changes: (b) gentle exercise—an eight mile walk on a fresh morning—had no apparent influence; and (c) rest in bed—for twenty-four hours, for example, spent in reading, with usual meals—did not abolish these diurnal variations. The facts obtainable from the observations suggested to Dr. Price-Jones that the variations in size of the red cells were due to differences in the reaction of the blood. Experiments *in vitro* showed that the red cells swelled with an increase of acidity, and shrank when the blood was made abnormally alkaline. Several simultaneous determinations of blood reaction and red cell diameters made by the investigator on himself, before and after short violent exercise, showed in each case that an increase in diameter was associated with a diminution in alkalinity. It is already known that at the moment of first awakening in the morning the blood is a good deal more alkaline than later on during the day; and while the kidney produces an acid urine during the night, in the morning it tends to become alkaline, presumably so that the blood may be more alkaline during the night and less alkaline during the day. Taking the work of previous investigators into account, the experiments and observations of Dr. Price-Jones appear to show, therefore, that the diurnal variation in the diameter of red blood cells is presumably due to the altered reactions of the blood; but whether the diminished alkalinity and increased diameters which prevail during the active part of the day are due to accumulations of CO_2 or lactic acid, or to some other source of altered reaction, we have at present no means of judging.

POST-GRADUATE INSTRUCTION IN PARIS.

EVEN if the tradition that it had its beginnings in the time of Charlemagne be rejected there can be little doubt that the Medical School of Paris is the oldest existing. A faculty of medicine was instituted in 1270; it formed part of the university, was dependent on the faculty of arts, and was subject to ecclesiastical authority. The medical faculty subsequently became independent, but the influence of the old association was shown in the rule, only abrogated in 1452, that the doctor of medicine should be celibate. For a time the Academy of Surgery was a rival institution, but both were suppressed during the revolution (1792), and replaced in 1794 by a single *École de Santé*. This school developed rapidly; the whole system of medical education was reorganized, and clinical courses were established in three hospitals specially equipped for the purpose. In 1808 the school became once more the *Faculté de Médecine*. The medical curriculum now extends to five years, and the State diploma, which alone gives the right to practise in France, is granted only to candidates who have passed through the whole medical course in Paris. Foreign practitioners can obtain, by examination, the diploma M.D. of the University of Paris, but this is a purely scientific distinction. Many of the professors in the faculty have arranged post-graduate courses; such courses will be given this spring in pathology, bacteriology, parasitology and pharmacology. During the summer and autumn there will be special clinical courses in many of the hospitals. Permission to work in the research laboratories attached to the various chairs is granted to suitable applicants at the discretion of the professor. Practical courses in bacteriology, physiology and biological chemistry are given at the Pasteur Institute, and here again suitable applicants may obtain permission to work in the research laboratories. The Institute, it will be remembered, possesses its own hospital for the treatment of infectious diseases. Paris possesses also the Institut Marey, which is fitted with all the apparatus for the study of movement by the graphic method; it is

¹ *Rev. de Méd.*, Paris, 1920, xxxvii, 441-466, 521-532.

² *Quart. Journ. Med.*, Oxford, 1918-1919, xii, 225-258.

³ BRITISH MEDICAL JOURNAL, 1910, vol. ii, p. 1418.

administered by an international commission. A Société des Amis de la Faculté de Médecine de l'Université de Paris has been formed to help it in various ways, especially by aiding in the improvement of its equipment and its research laboratories, and, by making French medicine better known abroad, to contribute to the advancement of medical science. This society has recently issued a pamphlet giving full particulars about the facilities afforded in Paris for medical and post-graduate education. Further information can, we understand, be obtained from M. Masson, Treasurer of the Society, 120, Boulevard Saint Germain, Paris.

THE COMING PARLIAMENTARY SESSION.

OUR Lobby Correspondent writes: The new session of Parliament will be opened by the King in state on Tuesday next, February 15th. The date is later than usual, and, Easter falling earlier than ordinarily, financial votes are likely to take up most of the time before the first recess. The Government's intention is to limit the legislative programme as much as may be, both for the sake of economy and to avoid autumn sittings. Pledges already given and necessary demands must, however, involve a large amount of business, and it is highly probable that members may show more controversial spirit as the period for a dissolution approaches and constituents have again to be met. The idea of a general election before 1922 is now generally discounted, although circumstances might bring it about sooner than is contemplated. The problem most affecting it will be the passage of a bill for the reform of the House of Lords. Whether this can be achieved by the end of the present session is doubtful; but a measure is promised, and after it has been placed on the statute book a general election will be required within a few months, as the constitution of Parliament will have been changed. Political prophets incline to the belief that this will happen in the spring of next year. Before that reform is attempted a number of other measures have to be faced. Prominent amongst these will be a bill to safeguard key industries, which may also tackle dumping, though that question may be taken up separately. A promise has been given for the reform of the Poor Law, to carry with it the ending of the workhouse system; but that, again, is a big matter which cannot be dealt with rapidly. Licensing legislation presents the same difficulty of needing a good deal of time for careful treatment. More urgent is a bill to clear up affairs in the hands of the Ministry of Transport—a department whose future will depend upon the policy to be determined within the session. The Ministry of Health alone has enough legislative work before it to occupy many contentious weeks in the House of Commons. Apart from the promise, as yet unfulfilled, to bring in a Poor Law Bill there are a host of matters to be proceeded with. First of all comes the question whether the Ministry of Health (Miscellaneous Provisions) Bill, rejected by the House of Lords at the end of last session, is to be reintroduced in the same form. The intention of the Cabinet in December was that this should be done, but there are strong arguments for separating the different proposals which, united in one bill, tended to form such a strong combination of critics against the bill as a whole. It seems quite possible, therefore, that the clause for providing a subsidy for house building may be detached, and that the clauses touching hospitals and homes for the treatment of incipient mental disease may be put into a single measure. No difficulty should be experienced in passing the Tuberculosis Bill, introduced last session, which is designed to transfer the exercise of powers from the Insurance Committees to local authorities, with the grant of certain additional powers to the latter bodies. The Patent Medicines Bill, which was carried to the Report stage in the House of Lords, will, it is hoped, be introduced in the House of Commons as a more or less agreed measure; and the same remark applies to the Dentists Bill, which

was framed on the report of a Select Committee. It is interesting to learn that the valuations of the friendly societies for health insurance are coming out favourably; they are not yet completed, but a large number of the returns to hand show a surplus, and the problem will arise how this is to be applied in increased benefits. Amongst the objects to which it might be devoted are dental treatment, convalescent homes, and, possibly, some allowance for treatment of insured persons in hospitals, which might render a little help towards the solution of the hospital problem. The Committee on Hospital Finance, of which Lord Cave is chairman, is meeting twice a week, and is making good progress in taking evidence.

RED CROSS WAR MEDAL.

THE British Red Cross Society has struck a medal for presentation to those of its many war workers who have received no British decoration or medal. Among those entitled to receive it are all members of the society or its voluntary aid detachments who during the war gave a minimum unpaid service at home or abroad of not less than a thousand hours. In the case of ambulance drivers and bearers the minimum number of hours is five hundred. For air raid duty, in the course of which great personal danger was often incurred, there is no fixed minimum period of service, and the Red Cross county presidents will nominate for the medal in their discretion. The medal, which is in gilt with a white ribbed-silk ribbon, is the only one ever issued by the British Red Cross Society. Engraved on the obverse is the well-known symbol, with the words, "For war service, 1914-1918," while the reverse bears the Red Cross motto, "Inter arma caritas." Forms of application can be obtained from the Secretary, British Red Cross Society, 19, Berkeley Street, W.1. Envelopes should be marked "B.R.C.S. Medal." We understand that those entitled to the medal will include medical practitioners who gave gratuitous Red Cross service during the war and have received no British award. The expression "during the war" means the period from August 4th, 1914, to December 31st, 1919.

DANGEROUS DRUGS REGULATIONS.

IN the JOURNAL of January 15th we announced the issue by the Home Secretary, under Section 7 of the Dangerous Drugs Act, 1920, of draft Regulations of a most drastic nature for the control of dealings in morphine, cocaine, ecgonine, diamorphine (heroin), and their respective salts, as well as in medicinal opium and in preparations containing not less than one-fifth per cent. of morphine or one-tenth per cent. of cocaine, ecgonine, or diamorphine. That the medical profession would be hampered by them in its legitimate use of these drugs was recognized by the Medico-Political Committee of the British Medical Association, and a protest, on general grounds, was at once made to the Home Office. Since then detailed representations have been drawn up and embodied in a memorandum submitted on February 3rd to the Home Secretary. This memorandum, together with the accompanying letter forwarded by the Medical Secretary, is printed in full in the SUPPLEMENT this week. The matter is one that concerns not only those medical practitioners who dispense their own medicines, but every practising member of the profession. We are all agreed as to the need for restricting, so far as is reasonable, the purchase and sale of habit-forming drugs; but there is a limit to what can be asked of busy practitioners. The official reply to the Association's memorandum has not yet been received, but in the meanwhile a statement by Sir Edward Troup, permanent Under-Secretary of State in the Home Office, has appeared in the *Times*. He emphasizes the point that the Regulations have not yet been made, and indicates several respects in which the draft seems to have been misunderstood. The Regulations, he explains, have been issued in draft

in pursuance of the Rules Publication Act, 1893, in order that all persons and bodies interested may have an opportunity of considering them and submitting any representations or suggestions before they are finally made; and he adds that all such representations or suggestions will be carefully considered. The medical profession will welcome also Sir Edward Troup's assurance that a doctor will not have to enter the fact in a book whenever he gives a hypodermic injection of morphine or otherwise administers any of these drugs. "The Regulations require certain records to be kept in cases where drugs are supplied, and these apply to doctors who supply medicines to their patients, as well as to chemists who supply them on a doctor's prescription. But there is no requirement that a record has to be kept of a personal administration of the drugs by a doctor." Consultation with the British Medical Association before the Regulations were drafted might, among other benefits, have prevented any misapprehension as to the exact meaning the official mind attaches to the verb "supply."

OXFORD OPHTHALMOLOGICAL CONGRESS.

THE Oxford Ophthalmological Congress will assemble at Keble College, Oxford, on the evening of Wednesday, July 6th next, and the meeting will be held on July 7th and 8th, with an extension to the morning of Saturday, July 9th, if needed. On July 7th a discussion on "The causes of infection after extraction of senile cataract" will be opened by Dr. Victor Morax of Paris. The Congress dinner will take place on July 7th, in the Hall of Keble College, and the Doyne Memorial Lecture will be delivered on the following morning by Dr. Ernest E. Maddox on "Heterophoria." Those wishing to contribute papers, pathological specimens, new operations, cases, or novelties, are asked to notify the Honorary Secretary, Mr. Bernard Cridland, Salisbury House, Wolverhampton.

RAT EXTERMINATION.

AN example of what can be done by the well-directed energy of a comparatively few enthusiasts, concentrating on one piece of work and doing that well, is shown by the results achieved by the Incorporated Vermin Repression Society, the annual dinner of which was held in London on February 8th. This society was the means of pushing the Rat Bill through Parliament, and after that useful object had been achieved it would have been wound up but for the fact that the Ministry of Agriculture urged the society to remain in existence to encourage its special propaganda. At the annual dinner, Sir Bruce Bruce-Porter, who was in the chair, gave figures of the enormous destruction effected annually by rats, and suggested that the Boy Scouts' organization might take up ratting as part of its work, pitting the brain of the scout against the nimble brain of the rat. Professor W. J. R. Simpson spoke on the rat as a carrier of disease, and Professor F. Hobday and others spoke from the agricultural and other points of view. Mr. Alfred Moore, the indefatigable honorary secretary, to whom much of the success of the society is due, mentioned that the society was going to offer its gold medal for the best rat virus that should prove harmless to human beings.

THE Conference of the International Union against Tuberculosis is being arranged by the National Association for the Prevention of Tuberculosis, 20, Hanover Square, London, W.1, and will be held in London from July 26th to 28th. Delegates from about twenty-five countries will attend and take part in the proceedings. Professor Calmette will open a discussion on the modes of diffusion of tuberculosis throughout the races of the world, and there will be three public addresses, given by a Frenchman, an American, and an Englishman. Visits to tuberculosis hospitals, sanatoriums, and laboratories will be arranged.

England and Wales.

PRESENTATION TO SIR ROBERT JONES.

ON January 31st, at the Adelphi Hotel, Liverpool, Major-General Sir Robert Jones was the guest at a dinner, with the Earl of Derby in the chair, on the occasion of the presentation of his portrait, subscribed for by the committee and staff of the Royal Southern Hospital, Liverpool. The portrait shows Sir Robert in the uniform of a major-general A.M.S., and was painted by the well known Liverpool artist, Mr. R. E. Morrison. Former residents and others had come from all parts of the country to be present, and among the apologues were those of Sir Anthony Bowly, President of the Royal College of Surgeons, and the Bishop of Liverpool. In proposing the toast of "The Guests," Lord Derby spoke in appreciation of what Sir Robert Jones had done, not only during the war, but before the war. He had first known him in connexion with his work for crippled children, and he could never forget the shout of delight of those children when Sir Robert went into a ward once with himself, when visiting the Children's Hospital at Heswall. He described the magnificent work which had been done by Sir Robert Jones during the war in organizing throughout the country that particular branch of surgery which he had made his own. There were thousands of men he said, at the present moment who were blessing the name of Sir Robert Jones for all that he had done for them. He was not only respected and esteemed as a great surgeon, but he was loved as a friend. Mr. G. P. Newbolt, senior surgeon to the Royal Southern Hospital, supporting the toast in an amusing speech, said that Sir Robert Jones was one of his oldest friends; they had worked together as young men at the Stanley Hospital, and as consulting surgeons for the Manchester Ship Canal works. In 1891, the year in which Sir Robert was appointed surgeon to the Southern Hospital, Owen Thomas died, and the full brunt of that surgical practice fell upon him. His reputation began to grow both on the Continent and in America, and his work in the war only added to an already great name. The toast was accorded with musical honours. Then Lord Derby unveiled the portrait, and in asking Sir Robert Jones to accept it said that Sir Robert would take this portrait away with him, but his friends would ever remain in their hearts a portrait no artist could reproduce.

Sir Robert Jones, in his reply, referred to the help and encouragement he had received from the chairman, when Minister for War, in his work in the military hospitals, especially in the creation of the curative workshops which had proved of so much value. He himself had but endeavoured to apply those surgical principles which had their birthplace in Liverpool, to the treatment of wounded soldiers at home and abroad. Those principles were associated with the name of Hugh Owen Thomas, the application of whose knee splint in the firing line had certainly reduced the mortality of compound fractures of the thigh in the war from 80 to 20 per cent. The first orthopaedic centre which he was asked to organize was opened at Alder Hey, near Liverpool, and the centres rapidly developed over the British Isles until nearly 30,000 beds were occupied. The knowledge gained should prove of immense value to the accidents in industrial life, and it had also resulted in a demand for orthopaedic education as a part of the student's curriculum. Although he was resigning the post of surgeon to the Royal Southern Hospital, he was retaining, in addition to the aftermath of military work, his connexion with various children's hospitals. He alluded to the pioneer work Liverpool, through the munificence of its citizens, had accomplished in the care and cure of cripples, and felt proud that Liverpool had maintained the lead in all that pertained to child well being.

Dr. J. E. Gemmell, President of the Liverpool Medical Institution, proposed the toast of "The Royal Southern Hospital," responded to by Mr. Thomas Woodsend, president of the Hospital Committee. Dr. C. J. Macalister proposed the toast of "The Guests," responded to by Dr. J. G. Adams, Vice-Chancellor of the University of Liverpool, and by Sir Berkeley Moynihan. Mr. T. R. W. Arnott, who acted as organizing secretary of the banquet, and to whose

indefatigable labour its memorable success is mainly due, proposed the health of the chairman, to which Lord Derby replied.

MANCHESTER ROYAL INFIRMARY FINANCE.

The annual report of the Manchester Royal Infirmary now issued, in addition to containing an account of the activities of this great provincial institution, raises some points of general interest in regard to hospital finance. The board, it is stated, have carefully considered the question of the admission of "paying patients," but hesitate to adopt a principle which is contrary to the spirit of the constitution of the Manchester Royal Infirmary. Careful inquiries are made, however, as to the financial status of each patient, and where it is found that patients are able to contribute towards the cost of maintenance while in hospital they are asked to do so. By this means a considerable sum is raised annually, and it is worthy of note that "the patients are almost always anxious and pleased to contribute." About 50 per cent. are quite unable to contribute anything. On examination of the statistics given, it is found that in 1920 £18,912 was received as payments from patients—including £1,870 from local authorities and £8,353 from the Ministry of Pensions after deduction of the proportion paid to the honorary medical staff—the corresponding sum received in 1913 being £4,222. It is pointed out that the sum received from the Ministry of Pensions will diminish and probably disappear in the near future; but one may hope that the income from local authorities as well as from the patients will correspondingly increase. Annual subscriptions, on the other hand, have increased only to £19,993 in 1920 from £11,002 in 1913. Such funds as the Hospital Saturday Fund and Sunday Fund, and congregational and workmen's collections, are surprisingly small, and have not increased to any material extent from 1913. Turning to the statistics of expenditure, the chief increases have been in the cost of provision (£9,630 in 1913, £29,479 in 1920), in fuel, light, and water (£3,498 in 1913, £10,966 in 1920), and in salaries and wages (£11,380 in 1913, £33,235 in 1920). These increases are, of course, general throughout the country.

As in other hospitals, therefore, the income from annual subscriptions does not in any way keep pace with the necessarily increased expenditure, but it must be obvious from these figures that, without sacrifice of the voluntary principle, a considerable income may be obtained by hospital authorities from payments by patients receiving treatment, particularly in a district where, as in Manchester—so far as one can gather from this report—workpeople's funds do not appear to be so thoroughly organized or to contribute so largely to hospital finances as they do, for instance, in Leicester.

Scotland.

EDINBURGH ROYAL INFIRMARY.

It is of interest to note the following comparative figures, which relate to the work and finances of the Edinburgh Royal Infirmary in 1920, as against forty years ago, 1881:

	1881.	1920.
In-patients treated	5,283	13,320
	(including fever)	
Out-patients	15,000	48,000
Daily average of in-patients	520	875
Average length of stay	31.6 days	34.05 days.
Average of deaths	8 per cent.	6.8 per cent.
Patients at Convalescent House	704	1,158
Daily average of patients at Convalescent House	43	61
Ordinary income	£21,902	£127,126
Extraordinary income	£6,572	£66,415
Voluntary contributions	£13,742	£88,482
Revenue from investments	£4,418	£16,838
Ordinary expenditure	£31,720	£130,667
Cost per bed	£61	£149 6s. 6d.
Stock and funds	£89,634	£479,031
Nurses and probationers on staff	101	312

OVERCROWDING OF MEDICAL STUDENTS IN GLASGOW.

In order to cope with the conditions attendant on the present overcrowding in the Faculty of Medicine at Glasgow, the Students' Representative Council at

Glasgow University have urged upon the Senate the need for certain improvements. The following resolutions have been approved by the Senate:

That in the departments of anatomy and physiology the staff of demonstrators be increased and more demonstrations given; that the number of hours' laboratory practice in anatomy be published in the calendar and no longer left to the decision of the professor; that the classes of fevers, diseases of sick children, and midwifery be confined to senior students; that the number of students attending the classes of fevers be increased; that three examinations be held annually in second and fifth professionals only. Final examinations to be held twice yearly, while the application by service students for a final in June will be considered.

Other proposals are still under consideration.

CARE OF LIMBLESS MEN.

The annual report of the Princess Louise Cottage Hospital for Limbless Sailors and Soldiers, Erskine, points out that while the number of pensioners admitted to hospital for treatment was diminishing in number, the pensioners who returned to Erskine for training had greatly increased. Since the hospital was opened, until the end of last year, some 6,146 in-patients had been admitted, about 9,496 patients had been fitted with new limbs and repairs to limbs, and 318 pairs of surgical boots had been supplied. The number of major operations was 69, making a total of 470 since the hospital was opened. Reference is made in the report to the services rendered in limb-making and fitting in the workshops and in the training of men for various trades. At the fourth annual meeting of subscribers, held on February 4th, in the City Chambers, Glasgow, Sir William Macewen recalled that when the hospital was launched he had pointed out that it was not the first issue of limbs alone that had to be provided for. Artificial limbs needed to be readjusted, repaired, and renewed throughout the lifetime of the men, and a generation would pass away before all the work connected with the limbless men in the great war was at an end. A great number of the men thought that, now that a little fuss had been made over them, they were to be forgotten. After speaking of the need for subscriptions, Sir William Macewen referred to the inquiry by the commission to which he had given evidence as to the future possibilities of the hospital. While he was not at liberty to speak meantime on that subject, they could rest assured that things were being fairly satisfactorily arranged. The workshops and everything else in Erskine were ready now to be made use of. They could take in quite a number of the severely disabled men, and he hoped arrangements would be made by the Government whereby such men could take advantage of the hospital, and the Government could subsidize or pay maintenance allowance for a certain number of them. Mr. David M'Gowan, in moving approval of the annual statement of receipts and expenditure, said that the funds they had raised showed that the people of Scotland, and particularly the West of Scotland, could rise to the occasion, especially when it was for the benefit of wounded soldiers. The motion was adopted. On the motion of Lord Blythswood a vote of thanks was accorded to the surgical and medical staff.

Ireland.

We regret to announce the sudden death of Dr. J. C. McWalter, late High Sheriff for the City of Dublin, who was well known in public and professional life in Dublin. We hope to publish an obituary notice in an early issue.

REPRESENTATION OF QUEEN'S UNIVERSITY IN THE ULSTER PARLIAMENT.

A joint meeting of the County Derry Branch of the Irish Medical Association and County Branch of the Irish Medical Committee was held in the Town Hall, Coleraine, on January 28th. Dr. Creery occupied the chair, and there was a large attendance of members. Dr. Charles Forsythe, J.P., moved two resolutions, one expressing the opinion that of the four seats allotted to the Queen's University in the Ulster Parliament at least two should

to held by graduates outside the Belfast area; and the other

"That, in recognition of Dr. H. S. Morrison's long service on behalf of medical and social reform, we nominate him as our candidate, and we commend his claims to all the branches of our associations and to the graduates of the university generally."

Dr. Lennox, J.P., Kilrea, Secretary, Dr. Magowan, Maghera, and Dr. Thompson, J.P., Bellaghy, supported the resolutions, which were unanimously adopted.

KING'S PROFESSOR OF MATERIA MEDICA.

Dr. T. Gillman Moorhead, Visiting Physician to the Royal City of Dublin Hospital, has been elected by the Royal College of Physicians of Ireland to the King's Professorship in Materia Medica in the School of Physic in Ireland. The vacancy was created by the resignation at the close of last year of Dr. Walter George Smith, who had held the chair for many years. There are four King's Professorships at the School of Physic—in practical medicine, in materia medica and pharmacology, in the institutes of medicine, and in midwifery. The Medical School of Trinity College, Dublin, founded in 1711, was incorporated in 1800 in the School of Physic in Ireland, established that year by Act of Parliament, and was placed under the joint control of Trinity College and the Royal College of Physicians of Ireland.

Correspondence.

SIR JAMES MACKENZIE'S THEORY OF DISTURBED REFLEXES.

SIR,—Granting the possibility of changes in reflex arcs of such a kind that an abnormal response is brought about, there seems no doubt that the phenomena must play a very important part in the symptoms observed in various diseased conditions. A few remarks from the point of view of a physiologist may perhaps be of some interest in the discussion.

Sir James Mackenzie refers to the action of strychnine, tetanus toxin, and similar agents which cause inco-ordinated reflex convulsions. I believe the nature of this effect was first analysed by Sherrington and shown to consist in the reversal of what is normally an inhibitory action by the afferent stimulus on the motor centres of the antagonists of those muscles concerned in the reflex movement, so that the result is simultaneous contraction of opposing muscles. This conversion of inhibition to excitation is particularly disturbing when inhibition is the chief part of the innervation process, as in opening the mouth by relaxation of the temporal and masseter muscles. As Sherrington points out, the greater the effort to open the mouth, the more powerfully is it closed, on account of the great power of the muscles which close the jaw compared with that of those that open it. This above-mentioned reversal was worked out by myself in its application to vasomotor reflexes, and it appears to be a very general phenomenon in nervous processes. I was also able to show that the pharmacological antagonists of strychnine, such as chloroform, chloral, etc., have the opposite effect in vasomotor reflexes, in that they convert the excitatory process into an inhibitory one, and it was shown soon afterwards by Sherrington and Sowton that the statement applies also to reflexes to voluntary muscles. The sequence of events in such a case as the effect of strychnine on the depressor reflex in the rabbit, may be of some significance. As the dose is gradually increased, we see at first an exaggeration of the normal vaso-dilator effect; this is step by step converted into a vaso-constriction and ultimately paralysed altogether. It appears as if reversal were a stage in the paralysing action.

It is not to be understood that reversals of this nature are only of toxic or pathological origin. They make their appearance in normal neural processes, as shown by the following experiment due to Magnus. The direction of the movement of the tail of a spinal cat, when the tip is pinched, varies with the position in which it hangs. This movement is always towards the stretched side, so that the same afferent impulse produces in one position excitation of those muscles which are inhibited in the opposite position. The condition of the centre must be changed by

receipt of afferent impulses from the stretched muscle. Sherrington and Graham Brown, moreover, showed that the sign of the effect from a particular cortical point varied according to whether other points were stimulated at the same time, and whether the point itself had recently been in activity. Thus, as is so frequently the case, the morbid process is essentially a running wild, as it were, of a natural one.

But in any case we realize what a wide field of research is opened up in the interpretation of symptoms on lines akin to this. It will be generally admitted that very little, if any, advance is made by the mere multiplication of symptoms recognized unless we know more about them. They may be merely indirect results of previously known ones. The analysis must be pushed further back in the way indicated by Sir James Mackenzie, while the correct recognition of the less obvious signs will greatly assist in this. We see also how the possibility of disturbed reflexes warns against hastily assuming a local manifestation to be due necessarily to a morbid process in this particular place.

Sir James Mackenzie points out that there may be a disturbance in the receptor or effector part of the reflex arc as an additional possibility to that already referred to concerning the nerve centre or adjuster. I may recall certain facts which suggest that an agent which normally produces a contraction of smooth muscle, by stimulation of the peripheral myoneural junction, may be reversed in its action by the presence of a toxic substance, so that it now causes relaxation or vice versa. This suggestion was made some years ago by Dr. H. K. Anderson, in explanation of the experimental fact, found by Elliott, that the contractile action of adrenalin may be converted by ergotoxine into an inhibitory one. I subsequently put forward the same view myself, in ignorance of Dr. Anderson's having previously done so. A similar effect is that described by Langley in the case of the bladder, in which stimulation of the sacral nerves causes inhibition after nicotine or curare, in place of the normal contraction; and that by Dale and Laidlaw, in which it appears that cytisine may convert the normal secretory effect of the chorda tympani nerve into an inhibition of secretory activity already in progress.

Our attention is also directed to the part played by the process called "facilitation" by Sherrington. In this a stimulus, itself below the threshold of activity, is made active by the simultaneous play of stimuli from other sources upon certain neurones in the course of its passage through the nerve centres. This is pointed out as being of especial importance in correctly estimating the value of symptoms of pain.

I thoroughly agree with the emphasis laid by Sir James Mackenzie on disturbances of blood supply. It is clear that a vital organ may suffer from want of oxygen, not only owing to failure of the heart or loss of circulating blood, but also from a local spasm of arterioles, which may well be due to a disturbed reflex.

Although I can lay no claim to express any opinion on clinical matters, it seems to me that the disturbance of reflexes described must undoubtedly take place, and, if so, a powerful means of analysing and interpreting the complex symptoms of disease has been provided. I am, etc.,

London, N.W., Feb. 3rd.

W. M. BAYLISS.

SIR.—The question of definition of the word "symptom," asked by my friend Dr. Harry Campbell, is one which has been the subject of much deliberation. In a sense the definition depends upon the use one intends to make of the definition. If it is only for purposes of abstract reasoning, one may easily become lost in a maze of logomachy, but if it is to be employed in the examination of patients there are several definitions of value. For this latter purpose we define *symptoms* as the reaction of the tissues to an injurious agent. We use the term freely, and do not differentiate it from sign—using the terms symptom, sign, and manifestation of disease interchangeably. By and by we may get a clearer definition, but the above definition represents the state of knowledge which we have reached.

Dr. Halliday Sutherland's objection to consumption being a secondary disease is possibly quite valid. In my twenty-eight years in general practice many of my patients developed consumption, but my recollection is that all, or most of them, were ill for years and frequently under my

care for a variety of complaints. It occurred to me that their complaints may have been due to conditions which predisposed to consumption. I quite realize that these preceding complaints may have been due to the action of the tubercle bacillus before declaring itself in the lungs. It shows the need of recognizing the symptoms produced by the invasion of the tubercle bacillus.

The well known fact that certain infectious diseases and certain drugs—which act as imitation diseases—give rise to a peculiar grouping of symptoms suggests that many obscure illnesses are due to a definite toxic agent. These agents may be recognized, not by the peculiarity of one symptom but by the peculiar grouping of symptoms. We find that many symptoms are common to a great many widely different disease agents, but that each agent produces a peculiar grouping of these symptoms. Though we recognized this, we made little progress until we found that there was some mechanism which was capable of producing a great number of symptoms, and thus we were led to the recognition of disturbed reflexes being this common mechanism.—I am, etc.,

J. MACKENZIE.

The Clinical Institute for Research,
St. Andrews, Feb. 7th.

A PROFESSOR OF MILITARY MEDICAL HISTORY AT THE R.A.M. COLLEGE, LONDON.

SIR.—We need at the Royal Army Medical College a Professor of Military Medical History, working exactly on the same lines as a Professor of Military History at an ordinary military college.

This suggested professor would trace out in his lectures the evolution of medical aid in war—and deal from the health point of view with the evolution of sanitary science—in our own and other armies. The tragedy of the Crimean war has gradually been forgotten; all that Walcheren stood for is well-nigh unknown, and we need to go back decade on decade into the history of the wars of the French Revolution and the Napoleonic era. I grew up in the army in the midst of the Crimean military surgeons, heard all the miserable story of the Crimean winter, and received from such descriptions an intense stimulus to army medical war developments. I sat for long hours, and times without number, listening to the story of Florence Nightingale's experiences from her own lips, and so needed no professor to stimulate my efforts at war betterment.

The moment the R.A.M.C. officers know that such a professorship as I propose will be founded their study of military medical history will be developed and further readiness for war responsibility will result. The cost of the professorship will be about £1,000 a year, and it will repay the nation hand over hand by its results. I do not now refer to sanitary science or military hygiene only; I include personnel, hospital administration, field medical discipline, the disposal of wounded in the past. One day, when we are better friends of the army officers, they will send us their professor of military history to give fourteen lectures each year, and we will repay the compliment by lending our professor of military medical history.

'Till this combination comes complete success is impossible.—I am, etc.,

GEORGE J. H. EVATT, M.D.,

Major-General Army Medical Staff (retired),

Junior U.S. Club, Charles Street, St. James's,
London, Feb., 1921.

SUGGESTIONS FOR A CO-OPERATIVE HEALTH SERVICE FOR LONDON.

SIR.—It is curious how often people may be thinking and working on the same lines quite unknown to each other. Whilst Brighton has been evolving its provident scheme, I have been working out a possible health service for London on very similar lines. The Brighton scheme, however, is apparently intended primarily for insured persons, whereas mine is intended in the first instance for that large section of the community whose incomes exclude them from the benefit of the National Insurance Act, but who are nevertheless unable to provide for themselves the present costly methods of diagnosis and treatment. To secure for them a complete health service, including general practitioners, consultants, and specialists, a well-equipped health centre and a private hospital is the

main object of the scheme, but seeing that there is at present no organized service of consultants and specialists under the National Insurance Act, such services would be thrown open to insured persons at specially arranged subscriptions. That the middle classes, who have been especially punished by the war and the high cost of living, require some method of obtaining the advice and treatment they require is hardly open to doubt, and from a study of statistics of the population and of the income tax returns I feel sure that it could be provided with great advantage to themselves and to the medical profession on the principles of insurance, whereby each breadwinner or income owner would pay a yearly subscription for himself and his family to cover the risk of requiring medical advice and treatment. The subscription would vary with the income earned or possessed and with the size of the family. Those earning under £300 a year would pay £1 15s. a year for himself and a similar sum for each member of the family, and the subscription would rise to £5 or £6 for larger incomes, and even more according to the limit decided upon, as shown in the accompanying table.

Subscriptions per Head of Insured Persons.

Unit of 1,000 Breadwinners and 1,000 Insured Persons, representing 4,240 Souls.

Incomes.	Breadwinners.	Breadwinners and Dependants.	Annual Subscriptions per Head.
Under £250	1,000 nationally insured.		£ s. d. 1 1 0
£ 250 — 300	325	1,052	1 15 0
300 — 400	225	729	2 0 0
400 — 500	96	310.4	2 7 6
500 — 600	74	237.2	2 15 0
600 — 700	55	179.8	3 2 6
700 — 800	45	144.2	3 10 0
800 — 900	35	115	3 17 6
900 — 1,000	28	92	4 5 0
1,000 — 1,100	20	64.8	4 12 6
1,100 — 1,200	17	55.4	5 0 0
1,200 — 1,300	15	48.6	5 7 6
1,300 — 1,400	15	48.6	5 15 0
1,400 — 1,500	15	48.6	6 2 6
1,500 — 1,750	20	64.8	10 0 0
1,750 — 2,000	15	48.6	12 0 0
Breadwinners ..	1,000	4,240	
Nationally insured ..	1,000		

In explanation of this table it must be pointed out that, according to the last census, in every 1,000 breadwinners over the age of twenty 300 are unmarried and 700 are married, and that each married couple is on the average responsible for 2.2 children; also that the number of persons earning the specified incomes are taken from income tax returns. The figures, as will be seen, are based upon a unit of 1,000 breadwinners with their families and 1,000 nationally insured persons. With 3,000 or 4,000 subscribing breadwinners the annual subscriptions could be reduced by 20 or 25 per cent.

The yearly subscription would entitle the subscriber to the services of a general practitioner, to medical aid in confinements, to the advice and help of consultants and specialists, to operative treatment, to the use of the equipment at the health centre, and to admission to hospital.

With the suggested scale of subscriptions general practitioners could be paid double the present capitation grant for nationally insured persons, and 5 guineas for each confinement. Consultants and specialists could be paid at any rate the usual pre-war consultation fees, and an average of about 35 guineas for operations. If subscribing members were admitted to voluntary hospitals, a donation of about £4 a week could be made to their funds, and the contemplated private hospital would do something to relieve the congestion of their waiting lists. Finally, when all these payments had been met, there would be a substantial balance for the running costs of

the health centre, which might eventually become a "Mayo clinic" for London.

At the present time a greatly extended scheme of compulsory insurance seems to be in the air, and this would not, I believe, be welcomed by those who have had experience of the working of the National Insurance Act. A voluntary scheme such as is here outlined would have the great advantage of keeping its control and management in the hands of medical men and their patients, and it might in time solve the whole question of an organized medical service "available to all citizens," such as the Dawson Report deems to be so necessary for the health of the individual and of the community. If successfully launched in London it could easily be extended to the provinces, and eventually to the whole country.—I am, etc.,

London, W., Jan. 27th.

CHARLES A. PARKER.

THE RISKS AFTER OPERATIONS FOR TONSILS AND ADENOIDS IN OUT-PATIENT CLINICS.

SIR,—I should like to thank your numerous correspondents who have shown their interest in the question raised in my original contribution in your issue of December 11th, and who have added so much valuable information. My purpose was simply to submit evidence that the risks of serious complications, even with carefully selected cases, are far greater when the patients are sent home soon after the operation than when they are kept in hospital for a day or two.

In some hospitals there is sufficient in-patient accommodation, and the operation can be performed under conditions which minimize the risk of complications, and which add greatly to the comfort of the children. In others, pressure upon beds renders this impracticable. Some of your correspondents have offered useful suggestions whereby the difficulty may be overcome.

It may serve a good purpose if I venture to draw attention to the recommendations in the Report for 1919 of the Chief Medical Officer to the Board of Education, Sir George Newman. Followed to their logical conclusion these leave little to be desired, and are in advance of the practice in some hospitals with special clinics. He emphasizes seven "points as regards arrangements for the operation which experience proves to be important." These include proper preliminary preparation of the child, a competent anaesthetist, and a skilled operator, and further—

"beds should always be available; primary subsequent care of the child in order to protect it from chill, dust, fatigue, and septic and other infections; secondary subsequent treatment . . . medical and nursing supervision during the days immediately following the operation . . . ; and partly after-care treatment, including appropriate and prolonged remedial and breathing exercises. All these matters, it should be noted, are important, not only to avoid accidents (for in any case these are extremely rare), but to secure the full and proper advantage of the operation."

—I am, etc.,

E. WATSON-WILLIAMS,

Surgeon for Diseases of Ear, Nose, and Throat,
Southmead Hospital and Royal Hospital for
Sick Children and Women, Bristol.

February 7th.

THE BRADFORD MUNICIPAL GENERAL HOSPITAL.

SIR,—In the JOURNAL of January 15th the above hospital was crushingly dismissed by Mr. Hall as "the same old obsolete group of buildings which the Local Government Board condemned as unfit for hospital purposes twenty years ago." It now appears (vide JOURNAL of February 5th) that what he really meant to say was that the Municipal Hospital "is a group of buildings unsuitable for the requirements of a general hospital," a portion of which (280 beds) was erected sixteen years ago, and sanctioned by the Local Government Board for hospital purposes. The present unsuitability of these buildings he ascribes to their having been "built for Poor Law purposes under the Poor Law regulations," and consequently to their sharing with many general hospitals the disadvantage of providing less than 1,500 cubic feet per bed. There is no criticism of their construction, lighting, heating, equipment, cleanliness, or nursing facilities; their condemnation rests solely on the inadequacy of the space per bed, which, in the buildings under discussion, is 1,115 cubic feet.

This deficiency could, of course, easily be remedied by

a reduction of 20 per cent. in the number of certified beds. By doing this all round, the Bradford Municipal Hospital could provide more than 1,500 cubic feet for each of 900 beds.—I am, etc.,

Bradford, Feb. 8th.

B. HOLROYD SLATER.

THE PREVENTION OF VENEREAL DISEASE.

SIR.—I am much obliged to Mr. E. B. Turner for the good opinion he expresses of me in his review of my book (BRITISH MEDICAL JOURNAL, January 29th). I hope my intimates, who are sometimes disrespectful, will read and inwardly digest. But Mr. Turner suggests that I exaggerate, and that I am unfair to the Royal Commission on Venereal Diseases and to the National Council for Combating Venereal Diseases.

As to exaggeration. After insisting in the beginning of the book that I am not in a position to estimate the prevalence of venereal disease from facts within my own knowledge, I give the official figures, and invite the reader to form his own opinion; but, of course, I state what the figures appear to mean to me—that is, if 10 per cent. of the population of the large towns suffered from syphilis before the war, if gonorrhoea is many times more prevalent than syphilis, if both diseases have since increased, if 79 per cent. of the population is urban, and if three out of four men get their infections from amateurs, the estimate that about half the population has been infected does not appear excessive to me.

As to the Royal Commission. This body was appointed "to inquire into the prevalence of venereal diseases in the United Kingdom, their effects upon the health of the community, and the means by which those effects can be alleviated or prevented." *Prevented*, be it noted. Metchnikoff published his discovery in 1906. The medical world rang with it. When the Royal Commission published its report in 1916 that discovery was under employment for the protection of the British Navy and some 20,000,000 soldiers on the Continent. Yet the Commission ignored Metchnikoff and prevention, and left the Government and the public to infer that there was no such thing. We have, then, two alternatives. It would be interesting to know which of them Mr. Turner prefers. Either the Commission was so ignorant that it had never heard of Metchnikoff and prevention, in which case it was intellectually unfitted for its task; or else it deliberately suppressed the truth, in which case it was morally unfitted for its task. As a fact, some of the medical members were anxious to consider prevention, but were told that any attempt to deal with it would wreck the whole inquiry.

The Commission warmly commended to the Government for its future guidance the newly formed National Council for Combating Venereal Diseases. In other words, it warmly commended itself; for the chairman of the one became the president of the other, and was followed by many members of the Commission to the directorate of the Council. At first it was proposed to call the latter "The National Council for the Prevention of Venereal Disease," but "Prevention" suggested the accursed thing and was changed to "Combating." To this day the lecturers of the Council are forbidden to mention prevention. The Council, a self-appointed body of private people, warmly supported by such dignitaries as the Archbishop of Canterbury, became extremely influential with a Government that was anxious to evade unpleasant responsibilities, and has been entrusted with the expenditure of increasingly large sums of public money. So financed, some of its members are now touring the world spreading the light as revealed to them. At least they will see the world. The policy of the Council has three principal features: (1) Morality is preached to adults and adolescents who, having already received their bias, have become unteachable, as any reader of the BRITISH MEDICAL JOURNAL may judge by examining his own consciousness and considering what effect moral lectures would produce on, for example, errand boys, factory hands, university undergraduates, and medical students. (2) The horrors of disease are expounded to prospective sinners who are thereby frightened from prostitutes to the pursuit of amateurs. (3) Clinics are thoughtfully provided to meet the resultant increase of disease.

Mr. Turner says that one of the most distinguished members of the Council was active in establishing the army venereal ablation rooms. But that is precisely what

I indicate in my book; I say that "a sort of bargain was made." In 1916 venereal disease was draining the army, and there was a dearth of trained men. The authorities wished to issue packets, which, though unnecessary in view of the abundant disinfectants available, would have constituted an attempt to bring quick disinfection within reach of every man. But "influential people" intervened, and the ablution rooms for "early treatment" were established instead—that is, for delayed and inefficient disinfection available only for men in camps and barracks. Later, dissatisfied with the results, I told the men in my charge:

"I have talked to you till I am tired, and you will go wrong. But I will not have you bringing these beastly infections into barracks where they are a danger to your comrades. In future, if you think you are likely to go wrong you must carry disinfectants and use them at once. If you bring a small bottle and ask my orderly, he will supply them."

After that for six months I had not a single case of venereal disease, and during twenty-eight months my rate of infection was 1.5 per 1,000 per annum. In the garrison generally it was 92. One officer wrote that owing to the nature of their duties he could not send his men for instruction; would I give him the heads of a lecture? I wrote a discourse in full, and a copy of it got into the hands of the authorities and was by them printed as a "specimen lecture" for medical officers. But it was altered. All my moral platitudes were left unchanged; but the gist of it—the insistence on immediate disinfection—was replaced by an injunction to get the disinfectants after return to barracks and then seek some retired place, "a w.c. or dark doorway," and there disinfect. Conceive it: the men were not even to disinfect as before in the ablution rooms. Imagine a sergeant-major—all sergeant-majors are great sticklers for the conventions—catching a man swabbing himself in a barrack doorway! The thing would have been positively dangerous. These sapient alterations were made, characteristically enough, by just that active and influential member of the National Council who, as Mr. Turner says, was so zealous in establishing the venereal ablution rooms. Still later, when the authorities resolved—in spite of the protests of those with whom I was associated—to introduce packet instead of instruction, the potent "influential person" again intervened, and the packets were used for "early treatment." Then followed the statistical acrobatics of the Ministry of Health which I described in my letter to the BRITISH MEDICAL JOURNAL of January 22nd.

Mr. Turner says that my advocacy of quick disinfection is built on "some extraordinarily good results" obtained by Surgeon Commander Boyden and me. He is good enough to attribute my success to "the fact that he is an extremely able, enthusiastic, and energetic man." But equally good results (described in my book, but not mentioned by Mr. Turner) were obtained in India and all over Hampshire and Dorsetshire. Were the scores of medical officers concerned all "extremely able, enthusiastic, and energetic"? I think myself that their distinguishing peculiarities were a genuine desire to prevent disease and the possession of a modicum of common sense.

But Mr. Turner appears to have done even better by means of moral teaching. "The result of a lecture was that . . . while that unit remained at the dépôt the number of cases of venereal disease diminished from 50. 40, 30, as the case may be, to 3, 2, 1, or none." Think of the splendour of that achievement! Can any reader of the BRITISH MEDICAL JOURNAL imagine his ideas of right and wrong and conduct being so profoundly altered by an hour or two of eloquent talk? Yet the like was done, and even among soldiers. But think also of the slackness and tarditude of the Government—with me, as the readers of the JOURNAL know, a favourite theme. Here was Mr. Turner giving occasional lectures for the National Council, and he would have been cheap to the nation at a million a year. I hope Mr. Turner will join in pressing for that inquiry into the past which the Society for the Prevention of Venereal Disease advocates.

Several correspondents have asked why the National Council and the Society, which are both anxious to reduce the prevalence of venereal disease, do not sink their differences and consult as to a common policy. Because they are separated by much more than a mere difference of opinion. It is necessary to speak bluntly. It is alleged that the truth has been suppressed, the untruth suggested,

and that there has been an actual falsification of records. The Society for the Prevention of Venereal Disease earnestly desire an authoritative inquiry into the past, feeling that otherwise—no matter what promises are made or what agreements contracted—it cannot trust the future. I speak only for myself, but I feel sure that if both societies unite in promoting such an inquiry all grounds of disagreement will soon vanish.—I am, etc.,

Southsea, Feb. 7th.

G. ARCHDALL REID.

SIR,—I am probably right in assuming that the members of the Society for the Prevention of Venereal Disease do not carry prophylactics for their own use, do not instruct their sons to do so, and do not see that their own children are instructed from an early age in the nature and danger of venereal disease and the methods of prevention. If I am right, what is the reason?

Doctors possess the racial instinct as other men, and are exposed to the same temptations, but they are trusted by their wives and patients, they are expected to be moral, and the very idea of the abuse of that trust is abhorrent to them. They have a moral control which is far stronger than the chemical aids to immorality which are advocated by the Society.

If this moral control is sufficient for doctors, it should also be sufficient for clergymen, lawyers and all men in a position of trust, for all those who are trusted by their wives, and for those who hope to marry pure women and have healthy innocent children. It may not be sufficient for those living in overcrowded unhealthy slums, but the remedy here is obviously one of bricks and mortar, and not one of chemicals.

I have five sons and two daughters and am alarmed by the propaganda carried on by this society. Any man or woman who allows a youth or young girl to believe that there is any necessity for them to give way to temptation does incalculable harm. I am grateful to the Medical Women's Federation for their opposition, and my alarm is lessened when I see that this opposition makes Sir Bryan Donkin forget his chivalry—an indication that his case is a losing one. I believe that when we are able to think in terms of peace we shall realize that measures that may have been advisable in the segregation of camps or in the neighbourhood of the battlefield are harmful and vicious amongst a civil population.

There is no reason why a healthy sane man should be unable to control his natural instincts, and if every woman would insist that men can and must keep straight, this society, which is lowering the moral standard of the country, would soon cease to exist. I believe that the men and women of this country are much more moral than the members of this society would have us believe. I am convinced that the only sound method by which we can really prevent venereal disease is by raising the moral standard, and by educating people, especially women, to realize that there is no necessity for men to give way and risk infection.—I am, etc.,

Reading, Jan. 31st.

S. GILFORD.

SIR,—The nation will eventually be grateful to those who are endeavouring to enlighten it. But while few would accede to the doctrine that preaching the use of disinfectants constitutes the sin of apostasy, others naturally hesitate to advise what they think might lead to immorality.

Little has been said of the loss of moral tone that is a sequel of venereal disease. The nervous system suffers. Periods of excitement lead to further excesses, and this involves spread of the disease. Depression is relieved by drinking. The general effect may well be set off against the possibilities involved in a widespread knowledge of disinfectants. Perhaps this argument—and it becomes more powerful the more carefully it is examined—may induce some to modify their views in opposition to the new proposals.

I think it is true that when man is in the mood he cares little either for morals or microbes. But it is equally true that, if not in the mood, if a pettecoat does not move him, permanganate will not do so. Aristotle quotes Homer as to "Charms that do steal the reason of the wise." Elsewhere, writing of sexual pleasure, he says, "No one engaged therein can think at all." In his saner mood man will reason correctly, but when moved by desire good

resolutions vanish. That this mood is periodic is recognized, and if a man can tide over the mood the period passes. This is the crux—how to get clear. The only common remedy I know is hard exercise and a purge. But many regard such advice as comic and stupid.

Early environment counts for much. Those growing up in crowded tenements are habituated to sexual knowledge. They are apt to regard the sexual pleasure as lawful, one akin to eating and drinking. Erotic literature and pictures are another factor. A campaign against these stimulating evils is needed.

There is one strong argument that affects most men. No ordinary sane man desires his wife's death by a repulsive disease, or her change into a feeble and useless creature. None desire hideous or deformed children. Even the wildest young bachelor has lying in his inner consciousness the hope of having healthy children eventually. Working upon this feeling—in itself part of the great law of reproduction—great success may be anticipated. I am inclined to suggest that we leave women out of the discussion for a time and tackle the men only. The reproductive process has two stages: (1) Initiation by the male, (2) conservation by the female. When the men fully grasp the position the women will follow suit.

If these considerations be approximately correct—and there is much others have written which must be included—we may find a common basis, which perhaps all will accept, and which might be formulated as follows:

1. Spread widely a knowledge of the effects of venereal disease, especially in producing idiotic and diseased children.
2. Instruct all boys. Insist upon the advantages of continence in rendering a boy fit to hold his own in games and studies.
3. Teach the practical value of hard exercise and a purge, perhaps bromides, in tiding over periods of stress the nerve storm is the real crux, as I have said.
4. Add: "But if you will make a beast of yourself, at least remember possible children, and use disinfectants."
5. Encourage men of all classes to join the Alliance of Honour, for definite short periods, with renewals.

I have for many years talked to officers and their men upon these subjects, and in my last Division I distributed a pamphlet (a copy of which I enclose). Later I saw many well-thumbed copies, and old soldiers expressed their appreciation. I speak of these results as evidence of receptivity. Although it is the reproductive principle that urges men to excess, another factor of the same principle is our strong ally—the love of children—and I feel sure we can make great use of this in our campaign.—I am, etc.,

T. M. CORKER,

Bournemouth, Jan. 31st. Major-General A.M.S. retired.

SIR,—Mr. Kenneth Walker's letter in your issue of February 5th, expressing in the main opinions with which my Society are cordially in agreement, yet shows that he shares with many others a misapprehension of the origin and scope of the Society for the Prevention of Venereal Disease.

This Society was founded solely to fill in the gap in the propaganda of the National Council for Combating Venereal Diseases left by their opposition to instruction of the public in the prevention of infection by means of immediate self-disinfection. My Society, while freely acknowledging that immediate self-disinfection is only one of many methods for diminishing venereal disease, believe that this method is an extremely important and valuable one, and our propaganda is devoted solely to bringing this method before the public, not because we are in any way whatever antagonistic to other methods, but because this method was not only neglected but actively opposed by the National Council for Combating Venereal Diseases. Our work is not in opposition to but complementary to that of the National Council.

In order to obviate overlapping, we confine our work to giving publicity to the one method not included in the useful and widespread propaganda of the National Council for Combating Venereal Diseases. The suggestion that we "regard it immediate self-disinfection as the single measure that will cure our ills" is therefore founded on ignorance of our published statements.

Again, we have times without number pointed out that we do not advocate the packet system, and in our letter

published in the *Times* of October 13th, 1919, which defined our policy, we stated:

"We decline to accept the description of our policy as 'the issue of prophylactic packets to the civilian community' in the way in which they were issued to H.M. Forces. No suggestion has yet been made by our committee as to the methods or means by which the public may obtain the necessary disinfecting material, the fact that such materials are easily obtained at any chemist being in our opinion quite sufficient. The aim of the committee is solely the instruction of the public."

Mr. Walker has summed up our wishes in his sentence, "let each of the societies work along the line it has chosen." My society would welcome the teachers of moral prevention as allies working along another line towards the same goal, if they on their part would accept the alliance of the teachers of medical prevention, and not waste valuable energy in opposition that is not only unnecessary but also hopeless as long as disinfectants are acknowledged to disinfect.—I am, etc.,

London, W.1, Feb. 4th.

H. WANSEY BAYLY.

STAG'S ANTLERS AND EVOLUTION.

SIR.—In the notice of Sir William Macewen's book on *The Growth and Shedding of the Antlers of the Deer*, in your issue of February 5th, your reviewer says:

"When regarded from the evolutionary point of view the stag's antlers are a great puzzle. It is not easy to see that they serve any purpose which, even if they grew once for all, would be commensurate to the expenditure of energy and material; as the antlers are shed annually, the puzzle becomes greater."

I venture, however, to think that from the evolutionary point of view the explanation is simple. It is obviously desirable that the fittest stag should perpetuate its kind, rather than the less fit, and if, after all the expenditure of energy and material associated with the annual development of the antlers a stag outlives its fellows in the struggle for the possession of the female, surely this is a very tangible proof that it is the fittest. If it were merely a question of the survival of the somatic individual, the expenditure on antler growing would no doubt be puzzling, but evolution puts very little importance on the individual *per se*.

The points referred to, namely, great expenditure of energy, the selection of the male which expends most, and the unimportance of the individual provided it achieves success in reproducing its kind, are simply illustrated in the case of the bee. The queen bee in her nuptial flight flies to an extraordinary height, and then only lets success fall on the drone in the swarm following her which is most powerful and energetic and proves it by leaving all the others behind. Having performed his function in life he falls dead.—I am, etc.,

London, Feb. 5th.

J. SIM WALLA E.

X-RAY RADIATION AND CANCER OF THE BREAST.

SIR.—The question of treatment by x-radiation has long since passed from the sphere of academic discussion into that of practice. Every practitioner now knows that there are many patients whom he cannot honestly advise on the best course of treatment without a more or less intimate knowledge of x-radiation and its influence on the normal and abnormal cells of the body.

In the case of various non-malignant diseases of the skin, etc., such knowledge is a refinement which possibly he may neglect and leave to the whole-time specialists in this subject.

In the case of malignant disease, however, this seems to me wrong, for we are here dealing with the immediate issue of life and death to the patient.

It is unfortunate that the problem in the latter case is more difficult than in the former, but just here the question of dosage is one of extreme importance, because on it depends the good or the potential harm which he may do.

However, nothing but good can come from the frank and open discussion of the matter. If our present practice is wrong the sooner we correct it the better; if it is right—and we are sure that we are on the right track—the more widely it is known and practised by the profession the more lives shall we save, and with so much the more confidence shall we advise and practise these methods. I

venture to suggest that we may safely start with the following postulates:

1. X radiation as at present practised will relieve and sometimes cure certain cases of malignant disease.

2. The doses are now sufficiently standardized for us to understand approximately what we are giving.

3. In the light of this knowledge up to the present date we can rely on the opinion of the recognized authorities on the subject for a candid statement on what we should do in certain common and well-defined classes of cases. I assume, of course, that all have first received, if possible, suitable surgical treatment.

It is not surprising if all authorities are not agreed on the actual details of dosage for all conditions, for are there not many other therapeutic agents of much greater age in which no uniformity of dosage has or can be established? It is doubtful if this will ever be possible. The reaction of the tissues to a stimulus or reagent must differ in individual cases, whether that stimulus be a radiation or arsenic or any other of the therapeutic agents at our disposal. We should, however, be wrong for this reason to refuse to use them.

I cannot help feeling that a frank statement of what we are doing, how we do it, and the results we obtain in the prophylactic and curative treatment of cancer of the breast will do a great deal of good, will save these methods from unmerited disrepute, and will fortify us in continuing what we believe to be useful work. I refer to cancer of the breast because it is in this connexion that Mr. Sampson Handley initiated the discussion, because these cases form a very large proportion of those whom we treat, and lastly, because we are here dealing with a superficial organ in which the loss in penetrating the tissues is smaller than in the case of more deeply seated tumours. For some considerable time—at the instigation of Mr. Sampson Handley—I have been treating these cases in connexion with my general practice, because it was only by doing so myself that most of them were able to obtain the treatment.

The method which I use, wherever practicable, is that recommended by Dr. R. Knox on pp. 461-465 of vol. II of his standard work on *Radiology and Radio-therapeutics*. I have also carefully watched the methods of treatment carried out under Dr. Salmond at University College Hospital, under Dr. Knox at King's College Hospital, and also, prior to his death, under the late Dr. G. R. Lyster, who was firmly convinced that in radiation lay the hope of the future for the cure of these cases.

Dr. R. Morton's letter of January 29th seems to me to do two things. First, it holds out, with some authority, a promise of a cure in the future; and, secondly, it casts an aspersion on our present methods.

The treatment we now give is with tubes having an equivalent spark gap of not more than 9 in., and by the use of aluminium filters of certainly not more than 6 mm.

It is agreed that the type of radiation necessary to deal with deeply-seated organs is a more penetrating one than that required in treating a superficial organ like the breast. Is it necessary in these cases to use a tube with an equivalent spark gap of 16 in.? At any rate, we do not at present possess them in this country. I write as a general practitioner determined to advise, and as far as possible give, the best treatment obtainable for this condition, and in doing so I believe I speak for a large number of practitioners who have the same object in view.

I appeal to the authorities on this subject to state their views on our present methods. We all wish to have our practice confirmed or condemned, or, better still, brought to perfection in this country as soon as possible, and we believe that by the careful thought and practice of British radiologists this object will be consummated.—I am, etc.,

Glastonbury, Feb. 7th. J. W. JAMES WILCOX, M.B., L.D.S.

THE DROOPING SHOULDER SIGN OF PHTHISIS.

SIR,—I was much interested in the remarks by Dr. W. C. Rivers, in your issue of January 22nd, on the drooping shoulder sign of phthisis, but in stating that this sign is not mentioned in any British textbook Dr. Rivers is in error.

The appearances to which he refers are fully described on pages 65-66 in Dr. Halliday Sutherland's *Pulmonary Tuberculosis in General Practice* (Cassell and Co., 1916).—I am, etc.,

London, S.W., Jan. 25th.

W. J. HOYTEN, M.D.

DEXTROSE IN CARDIAC FAILURE.

SIR,—I can corroborate Dr. Scott MacGregor's recommendation (January 29th, p. 158) to give sugar an extended trial in cases of cardiac failure.

In 1913 I published a case in the *Lancet* (vol. i, p. 1992) which is quoted in Marlindale's *Extra Pharmacopoeia* (1915) as follows:

"Life saving by sugar: 8 oz. during twenty-four hours in a case of a woman of 77 with heart disease, where digitalis and digitalin had no effect. Continued some weeks in slightly less amount. Strength slowly regained."

I frequently put my bad heart cases in the Hull Royal Infirmary on sugar in some form—often dissolved lump sugar—as well as bad cases of pneumonia—with good results.

The members of the sugar group of carbohydrates form an easily assimilated food, which sustains and increases the power and endurance of all varieties of muscle fibres; and some form of sugar is always at hand in any household.—I am, etc.,

Hull, Feb. 3rd. STANLEY E. DENYER, C.M.G.,
M.D. Camb., F.R.C.S. Eng.

THE NAVAL MEDICAL SERVICE.

SIR,—In the *JOURNAL* of January 29th "Surgeon Commander R.N." passes, in a spirit of unctuous rectitude, rather severe strictures on his colleagues. That these charges are ill deserved, and, further, that they are not the cause of the present lamentable condition of the Naval Medical Service, we hope to make clear.

He states that a class of man is attracted to the service who is no use either in or out of the service. We frankly disbelieve this, as until recent years the competition to enter into this branch was about 2 to 1, the selected candidates being mostly highly trained, many of them prizemen, and many ex-house-surgeons and ex-house-physicians. There has been a great exodus of these good young men during the past two years, and if the Admiralty would only permit it, there would be a still further reduction. They are retained in the service, not by any hope of advancement—they have less than a 1 in 20 chance of promotion to surgeon captain—not by the prospect of a "life of leisure and retirement at age 50 with a nice pension of £600," but by the force of the Naval Discipline Act; those who wish to leave are not allowed to. Further, it is remarkable to how very few temporary surgeons, who saw the navy from within, these alluring prospects appealed, and now the Admiralty cannot even get as candidates those whom your correspondent refers to as "idlers and grubblers" and "of no use either in or out of the service."

He asks, What has the average naval surgeon done for the service? Our reply is that he has rendered loyal and honest service in return for emoluments much below the market rate. Contrary to "Surgeon Commander's" statement, the Health of the Navy returns show a progressive decline in the amount of preventable sickness. We have yet to learn of any naval medical scandals during the late war. The naval doctor does not work in the limelight, and the merest glance at the current *Navy List* will show the meagre list of humble O.B.E.'s with which officialdom has recognized his work.

In reply to the painful comparison with the R.A.M.C., we would say that so long as the combination of pay, allowances, and other pecuniary advantages exceeds ours, so long will a justifiable grievance remain, and so long will the other service have first choice of those candidates who wish to enter the "Services." If we must not reasonably compare ourselves with them, with whom we ask, should we seek comparison?

One can remember the days when the R.A.M.C. did not stand on its present pinnacle of efficiency. It dates its swift rise to fame from the day that it began to "run its own show." There may be some hope for the Naval Medical Service when the Medical Director-General is allowed to become more than a mere figurehead, whose function it is to make occasional recommendations to the Board in whose unprofessional hands the real destinies of the Medical Branch at present lie.

The lack of clinical material in ships is admitted, but do the Admiralty try to obviate this defect by sending medical officers awaiting employment to naval hospitals where there is no lack of good cases, and much really good work

is done? No; they are put on unemployment pay instead. It is, we think, obvious that your correspondent can have had little experience of the work done in naval hospitals—work which compares favourably in quantity and quality with either that of the army or of civilian practice.

Your correspondent thinks that it is high time to put an end to grumbling, and recommends work in lieu, remarking that as the labourer is worthy of his hire so would we have gained the recognition, status, pay, and honours deserved. We might reasonably assume that when the medical officer, by much good service and careful selection, attains to the rank of surgeon rear admiral, he has already attained some distinction, and as such is entitled to generous treatment, but it is common knowledge that his emoluments are in no way adequate, without considerable private means, to enable him to live as he is generally expected to live. When an executive officer attains this high rank a benevolent Admiralty makes the possession of private means unnecessary by the provision of very handsome allowances. Few of us can afford to be so altruistic as to view these matters with the equanimity of your correspondent, nor do we consider that the rewards of our very senior officers are now such as to attract the best men. It is therefore frivolous to speak of the prominence we give to these grave inequalities in treatment of senior officers as "grumbling about status."

It is the merest truism to say that a medical officer's personal status is what he makes it. The medical officer who is his captain's personal friend and confidential adviser is the rule and not the exception, and in this way he does much good work for the service which your correspondent has overlooked. The differentiation in official status is sufficiently shown by the comparison quoted above.

So much for destructive criticism. Of constructive suggestions for improvement of the branch we know there is no lack.—We are, etc.,

Feb. 1st.

TWELVE MEDICAL OFFICERS ROYAL NAVY.

SIR,—I cannot allow the attack on his own branch by one who signs himself "Surgeon Commander" to pass without a reply.

He asks, "What has the average naval surgeon done for the service?" In many cases during the late war he died for it. Possibly in this act your correspondent might admit that the naval medical officer "stood on his own merits." Your correspondent has apparently never read the *Naval Medical Journal*. Since its beginning in 1915 this journal has been a revelation of the extraordinarily good work that naval medical officers are doing both in preventive and other branches of medicine and surgery. In it there are many excellent articles written by men often in isolated ships on distant stations showing the resource and skill by which they extemporized apparatus for laboratory or other work on board ship. The journal alone is a complete refutation of your correspondent's ignorant charges. If naval medical officers had been such as he describes, there would never have been such a journal.

The health of the Grand Fleet during the war, and the records of the treatment of the sick and wounded all over the world, are a sufficient testimony that the naval doctor knew his duty and his job, and did both. There has never been a word of hostile criticism of the treatment of all those thousands of sick and wounded during the war.

To our poor branch that gets all the kicks and none of the halfpence this fact alone is ample justification. In his last paragraph your correspondent infers that the Naval Medical Service is not "a worthy unit of the great service to which we belong." To this I can only reply that if every other branch had been as well equipped and ready for war as the medical, the war would probably have been over considerably earlier.—I am, etc.,

January 31st.

ANOTHER SURGEON COMMANDER.

☛ We have received other letters to much the same effect.

AGE AND PENSIONS.

SIR,—Two propositions of the Pensions Ministry are having the effect of disfranchising very large numbers of old soldiers from pensions:

1. In disease disability, not due to but aggravated by service, the pension ceases when the "aggravation" is said to have "passed away."

2. Many disease disabilities of elderly soldiers are said to be "due to age" and not to service; such disabilities, being due to age, cannot be "aggravated by service," and in either case are ruled to be not pensionable.

The fallacy of these propositions requires demonstration. First, as to causation of disease disabilities, the originating causes of every disease are multiple; all diseases are the resultant of innumerable causes. Military service is itself a multiple cause. When a disease is said to be "attributable to" or "aggravated by" military service, the admission of this particular element of causation, by the Ministry's own rules entitles a soldier to pension for the full disability, whatever be its other contributing causes.

The disease or disability resulting from these multiple causes consists of two aspects, functional and organic: (a) a physiological defect of vital reaction to environment and strain; and (b) a pathological material change in the tissues. On the upward curve of life, while the *vis vivendi* is potent—up to the age of 35 or 40—recovery may be complete, the residual defect of vital reaction and the residual tissue change being inconsiderable; no appreciable "disability" remains. On the downward curve of life, when the *vis mortis immanens* is increasingly potent—after 35 or 40—the residual defect, both in function and in tissue change, usually remains substantial, and cannot "pass away." They render the man increasingly liable to microbial invasions, and impair his general economic efficiency and his reactions to all strains.

The "physical picture" is quite unreliable in measuring the organic disease disabilities of elderly soldiers. By direction of the Ministry's assessors, disabilities are at present assessed by the medical boards mainly, often exclusively, on the "physical picture" recorded by the Board, although the *Manual* clearly directs that all the factors bearing upon the degree of disability are to be taken into account. Experience increasingly shows that in elderly pensioners with chronic disabilities a physical examination gives at best but a few bald positive or negative signs, "a picture" which cannot in itself measure that impairment of general function which constitutes the economic disability of the pensioner in earning his livelihood. The chronic disabilities from which these elderly pensioners suffer are, in the nature of the case, usually of long standing and more or less incurable, liable to more and more frequent recurrence and accentuation as years go on. The illness may "pass away" temporarily, but only in appearance, for each recurrence leaves an increased histological tissue change in the organs affected (not usually verifiable by a physical examination) and an increased tendency to recur. In men on the downward incline of life these consequences cannot in any true or lasting sense "pass away"; on the contrary, they are bound to get worse with time. The actual assessment of these chronic cases is difficult for the following reason:

They cannot justly be assessed by any abstract "comparison of the disabled man with an average healthy man of his age," as laid down by the Ministry. There is no such thing as "an average healthy man of 60"; the healthy men of 60 are a very minute fraction of the sum total of men of 60 surviving at all. There is no average standard of physical condition in elderly men of any age. Truly considered, they are merely the tougher constitutions surviving—and the toughest constitutions may be the most disabled—out of the far greater age-group of their year of birth.

The only standard of any value by which the economic disabilities of elderly men can be measured is the age factor, which has always been ignored or misunderstood or perverted by the Ministry. These disabilities are intimately bound up with the age factor, and the just assessment of elderly soldiers requires that an age factor should in all cases be added to the purely "physical comparison" assessment.

The distinction drawn between cases of disease disability directly attributable to service, and those assumed to have pre-existed before enlistment and to have been "only" aggravated by service, is in many instances artificial and hypothetical. Even when there is proof of pre-war disease, we have usually no evidence at all of the degree of disability on enlistment. When, therefore, after or on demobilization, a case is accepted as "aggravated by service," the pre-war part of the whole present disability has to be assessed by guesswork, several years after the date under assessment, the whole effect of military service intervening. These guesses obviously are variable and of very little value; the very basis of this disfranchisement

of these older soldiers has no true foundation either of record, of science, or of fact.

The only use the Ministry has made of the age factor is a perverse and unscientific one. In order to dispose finally of the whole age question it has laid down the following propositions:

1. "We are not here to assess disabilities attributable to age." "We are not distributing old age pensions."
2. "Disabilities attributable to age cannot be attributable to service."
3. "Therefore the disabilities of a soldier attributable to or aggravated by age, are not pensionable."

But age is not in itself a cause of anything, so that it cannot either be a cause of disability or exclude any cause of disability, such as service, from acceptance. Age is an approximate measure of innumerable chronic disabilities, whose causes are the same multiple causes which produce the disabilities of all ages. As age advances the tissue changes resulting from disease causes in general (including military service as a cause) become accumulated, and the defect of vital reaction to environment becomes aggrandized, but age remains simply the measure of accumulation, not the cause of the accumulated organic and functional disability. Age in itself is a relative term, a mental concept; considered as a measure of time, a measure of man's life span, it cannot cause disability. We speak of "age-disability" only as a convenient figure of speech, as a concurrent measure of accumulated disability. The perversion of this figure into the formula or belief that "age is a cause of disability" is muddleheaded and unscientific.

In practice the disabilities of older soldiers, though very real in economic effect (to compensate for which is the true purpose of disability pensions), are often difficult to define in the terms of disease. The truth is old age is a disability, which may be and usually is aggravated by service, and that aggravation cannot pass away. The assessing branch of the Ministry appears to have been overweighted by the difficult decisions required of it in the shortest space of time. Its incorrect premiss disfranchises elderly soldiers from the benefit of the Royal Warrant, which (correctly applied) was intended by Parliament to safeguard the interests of all soldiers, old or young, injured by their service in the army, and not least those who served in their old age.—I am, etc.,

January 28th.

AETAS.

BRITISH AID FOR RUSSIAN MEN OF LETTERS AND SCIENCE.

SIR,—At the beginning of this year you published an appeal for funds to enable a certain number of scientific and literary publications to be sent to the House of Science and House of Literature in Petrograd, where the remnant of the intellectual life of Russia is mostly congregated. The British Committee for Aiding Men of Letters and Science in that country has assured itself that such publications will reach their destination, and has made arrangements for their transmission. There are probably many authors who would be willing to send copies of their works in the form of excerpts or otherwise to Russian workers who have been cut off from the outside world since the revolution. The British Committee will be glad to receive any such books or papers of a non-political type and to send them to Petrograd. It cannot guarantee delivery to individuals, but it can ensure that publications will reach the Houses of Literature and Science. Parcels for transmission should be addressed to us, care of Wm. Dawson and Sons, Ltd., Continental Department, Rolls Buildings, Fetter Lane, E.C.—I am, etc.,

L. F. SCHUSTER,*

Secretary.

British Science Guild Offices,
6, John Street, Adelphi, W.C. 2.
January 25th.

By the will of the late Mr. William Roper Teage of Dartmouth, who left net personalty of £73,487, the residue of his property is left to charitable institutions, including ten parts to the South Devon and East Cornwall Hospital; four parts each to the Dartmouth Cottage Hospital and King Edward's Hospital Fund; two parts each to Guy's Hospital, the London Hospital, and the Poplar Hospital; and one part each to the Middlesex Hospital, the Cancer Investigation Department of Middlesex Hospital, the Royal London Ophthalmic Hospital, and to three special hospitals in Plymouth.

Obituary.

F. H. DAYUS, M.R.C.S., L.R.C.P.,
Forest Gate.

DR. FREDERICK HERBERT DAYUS, Chairman of the West Ham Insurance Committee, died at Cumberland Lodge, Forest Gate, London, E., on January 26th. After studying at St. Mary's Hospital, he obtained the conjoint diploma in 1893. He was subsequently appointed resident casualty officer at St. Mary's Hospital, and served as resident medical officer to the London Fever Hospital. After a brief period of practice in the county of Durham, he established himself in West Ham, where he speedily obtained an extensive practice. He was always an enthusiastic supporter of the British Medical Association, never wearying of pointing out that it was the only possible organization for the profession. He joined the executive of the Stratford Division in 1907, and retained his seat thereafter. He was vice-chairman of the Division during the years 1911-12, while the National Insurance Act was under discussion, and was frequently called upon to preside over the large meetings which gathered during those troubled times. He was a member of the West Ham Panel Committee since its formation, and its first chairman. He was elected by the practitioners of West Ham as their first representative on the West Ham Insurance Committee, and his annual re-election became a matter of course. He served as chairman of the Sanatorium Benefit Subcommittee, and was a member of the Medical Benefit Subcommittee from the beginning. In 1920, having served a year as vice-chairman, he was unanimously elected chairman of the West Ham Insurance Committee, and this office he held at the time of his death. He thus shared with Dr. Dain of Birmingham the distinction of being one of the two medical chairmen of Insurance Committees. In this office he excelled; his knowledge of men, his tactful and conciliatory bearing, and the firmness and decision of his rulings made him almost ideal, and his assiduous attendance at subcommittees kept him fully conversant with all the committee business. Dr. Dayus was also a member of the local War Pensions Committee, and honorary medical adviser to the Stratford Day Nursery and to the Mothers Welcome of the Trinity Oxford City Mission.

Early in life he became a Freemason, and entering into it with his characteristic zeal, he rose to high office. In the midst of these multitudinous activities his advice and assistance were always at the disposal of those that sought them; no call upon him was ever made in vain, and his death at the early age of 52, in the full tide of his career, adds one more to the long line of medical men who have paid for their devotion to the public with their lives. The funeral service, which took place at West Ham Parish Church, within a few yards of the place where he had carried on his life's work, was the occasion of a remarkable demonstration of feeling. The large building was completely filled by a gathering fully representative of all the numerous bodies with which he was connected, together with friends and patients, but far more impressive was the scene outside, where thousands of people packed the streets and waited patiently in a dreary drizzle throughout the service to see the last of him who had served them so well.

WE regret to announce that Mr. HENRY BARTON OWENS, M.R.C.S. Eng., L.R.C.P. Lond., of Paulerspury, Towcester, Northants, died on January 15th, after a week's illness, of acute septicaemia, in his 32nd year. Born at Long Stratton, Norfolk, he was the second son of Charles A. O. Owens, M.D., J.P., who has practised there for nearly fifty years. On leaving the London Hospital he became house-surgeon at Poplar Hospital. At the outbreak of the war he obtained a temporary commission in the R.A.M.C., dated August 8th, 1914, and was posted to the 3rd Cavalry Field Ambulance at the Curragh. He went overseas with the first expeditionary force in the 1st Cavalry Division, and was very soon attached to the 4th (Royal Irish) Dragoon Guards. Among the many battles he was engaged in were the retreat from Mons, Le Cateau, Marne, Aisne, Ypres, Somme, Amiens, and in the final advance. He was a long time with the 57th Field Ambulance, 19th Division, taking his turn as medical officer to several battalions, including the Royal North

Lancshires and also the Royal Engineers. He was twice mentioned in dispatches. His name appears in Colonel Breton's book, *The R.I.M.C. in the Great War*. One of his comrades with whom he was closely connected during the war writes: "Many a time have I been cheered by his company and courage in France, where his gallantry and devotion to duty were so inadequately rewarded, though fully appreciated by his real friends." He was a keen sportsman, never happier than when following hounds, and was well known as riding true and straight with several packs in Norfolk and co. Tipperary. He was gifted with a facile pencil, many of his sketches and water colours done in France during the war possessing additional interest in the fact that some of the places represented no longer exist. He married, in July, 1920, Winifred Mary, daughter of the late Henry Mandeville, R.N., of Anner Castle, Clonmel, co. Tipperary. In October he commenced practice at Paulerspury, where he died.

We regret to announce the death of Dr. PATRICK CHARLES GORHAM, of Clifden, Connemara, who for nearly fifty years had been connected with the medical life of West Galway. Dr. Gorham was educated at Queen's College, Galway, and at Dublin and Edinburgh, qualifying L.R.C.P., L.R.C.S. Edin. in 1874. He was for forty years medical officer of health of Roundstone and Clifden districts, and medical officer to the Clifden workhouse and fever hospital, but failing health caused him a few years ago to accept superannuation. A colleague writes: For a considerable time it was known that Dr. Gorham was in failing health, but when the news came that he had passed away the expressions of regret and sorrow were many, and the funeral cortège was the largest seen in Connemara in living memory. Those who were admitted to his friendship, and his poor patients in particular, held for him an especial regard and love. Among the visitors who made Connemara their headquarters for fishing, shooting, and other sports, Dr. Gorham was a special favourite, and he numbered among his friends Lord Randolph Churchill, Mr. George Wyndham, and a host of other well known people. When the Poor Law Association wished to promote a measure of superannuation for the Poor Law officers of all grades, they availed themselves of his friendship with Mr. Wyndham by constituting Dr. Gorham their chief spokesman, with the result that the Chief Secretary undertook to forward their interest, but owing to political opposition he was compelled to abandon their case. Dr. "Pat" Gorham in his love for his poor patients and striking example of devotion in the pursuit of his duty has left to his colleagues in the Poor Law medical service an example and an inspiration. In his family of six brothers, of whom two now survive, four selected medicine as their profession.

We regret to record the death of Dr. PHILIP G. NUNN, at Bournemouth, on January 10th, in his seventy-third year. He received his medical education at St. Bartholomew's Hospital, and took the diplomas of M.R.C.S. in 1871 and L.R.C.P. in 1873. In 1874 he was appointed medical officer of health for Bournemouth, and he continued to hold that post, with the exception of about four years, till he retired in 1911, when he was appointed consulting medical officer of health. During this period the population of Bournemouth rose from 7,000 to over 80,000. Dr. Nunn was consulting surgeon to the Royal Boscombe Hospital and an ex-president of the Dorset and West Hauts Branch of the British Medical Association.

Dr. EDMUND J. SPITTA, who died on January 21st, aged 68, received his medical education at St. George's, St. Thomas's and Westminster Hospitals, and obtained the diplomas of L.R.C.P. and M.R.C.S. Eng. in 1874. He was prizeman in anatomy at St. George's Hospital Medical School and held the post of senior demonstrator in anatomy. He joined his father in practice at Clapham in 1874, and retired in 1904, when he removed to Hove. In 1899 he brought out his book on *Photomicrography*, and that on *Microscopy* in 1907. At the request of the British Government he showed, in conjunction with his son, Dr. Harold Spitta, M.V.O., Bacteriologist to the Household of H.M. Queen Alexandra, a series of photomicroscopical exhibits

at the Paris International Exhibition in 1900, when he was awarded the Grand Prix. He was also awarded a gold medal for his exhibits at the exhibition at St. Louis in 1902. On retiring from practice he devoted himself to research work in microscopy and photography, and was the first scientist to produce cinematograph pictures of plants and insect life. Dr. Spitta was a Fellow and Vice-President of the Royal Microscopical Society and was President of the Quekett Microscopical Club in 1904-8. In recent years he was greatly interested in wireless telegraphy, and at the time of his death was engaged on experiments in wireless telephony.

The death has occurred, at the early age of 25, of Dr. ROBERT DAVID JONES of Penrhynendraeth, Merioneth, as the result of a railway accident. He was the son of Dr. J. R. Jones of Penrhynendraeth, and received his medical education at the University of Liverpool and St. Bartholomew's Hospital. He was awarded the Torr gold medal in anatomy at the University of Liverpool in 1914-15, qualifying M.R.C.S., L.R.C.P. in 1918. He had been senior house-surgeon at St. Bartholomew's Hospital, and had served as captain in the Royal Air Force Medical Service. Dr. Jones only returned a few days before from a short trip to India.

We regret to record the death of Dr. GEORGE NISBET, of Quinton House, Kirkby-in-Ashfield, Notts, which took place, after a long illness, on January 16th. Dr. Nisbet received his medical education at Edinburgh University, and qualified in 1904. A well known and popular practitioner, he took a great interest in the work of the British Medical Association, and acted as local secretary in the Kirkby district of Nottinghamshire.

Medico-Legal.

ACTION AGAINST A MEDICAL OFFICER OF HEALTH.

In the *JOURNAL* of July 31st, 1920, p. 188, an account was given of the action for damages for libel brought by Mrs. Mabel Copeland against Dr. Thomas Orr, the medical officer of health of the borough of Ealing. The case was heard in the King's Bench Division on July 15th before Mr. Justice Roche and a common jury. The plaintiff was a lady sanitary inspector in the service of the Ealing Town Council. The jury found £25 damages in favour of the plaintiff, but the judge postponed the entering of judgement pending legal argument. Four days later, in the same court, Mr. Hemmerde, K.C., counsel for the defendant, moved that judgement be entered for the defendant on the ground that there was no evidence of malice. Mr. Justice Roche, in the course of an argument by counsel on both sides, used the following words: "It is not for me to set the jury's verdict aside as being an unreasonable verdict, but I am entitled to say that I am very dissatisfied with it. It is difficult, however, to say that there was no evidence which could be submitted to the jury." Judgement was therefore entered for the plaintiff for £25, and the defendant entered an appeal.

In the Court of Appeal, on February 2nd, before Lords Justices Bankes, Warrington, and Atkin, Dr. Orr's appeal was heard. An account of the hearing was printed in the *Middlesex County Times* of February 5th. According to this report, Dr. Orr appealed on the two grounds that the judge was wrong in not withdrawing the case from the jury, because there was no evidence of malice to go to them, and, alternatively, that even if there was evidence of malice the verdict was against the weight of the evidence. Mr. Bell Hart, instructed by the Town Clerk of Ealing, said that Dr. Orr took up his duties as medical officer in August, 1915, and the respondent's case was that from the first he adopted a harsh attitude towards her, often complaining of her work and requesting her to be more methodical and to conform to certain new regulations he had made; her health thereby became affected. It was not suggested that Dr. Orr made any sort of report detrimental to the plaintiff before April 10th, 1917, but on that date he was asked by the council to report on her work, and in response he spoke the words which the respondent maintained were slanderous. Counsel then went into the detailed evidence given at the trial, and in support of the appeal he laid stress on the fact that Mr. Justice Roche had himself expressed dissatisfaction with the verdict.

Lord Justice Bankes, giving judgement, said the amount of damages awarded was very small, but the principle underlying the verdict was very important, because were the verdict allowed to stand the impression might be produced that if any person did not get on well with a superior officer, and was necessarily taken to task by that officer for not performing his or her duties to the officer's satisfaction, and if, further, the officer felt compelled to make a report on the matter, the evidence was to be taken as evidence that he had acted maliciously in making the report. In this case there was really no evidence fit to be submitted to the jury that Dr. Orr acted maliciously on what was admitted to be a privileged occasion, or that he had been

animated by ill-will at all. After referring to the relations between Dr. Orr and Mrs. Copeland, his Lordship said it appeared to him that so far from the doctor having shown malice, he was forbearing and was anxious to take a step which might not do the lady harm. Referring to a letter sent by the respondent's sister to Dr. Orr, his Lordship said it raised a grave matter, because it suggested that, owing to the doctor's attitude, the respondent had so suffered in health that she could not perform her duties. It was incumbent upon the doctor when he received that letter to bring the matter before his superiors, and he did so on April 30th. That was not done voluntarily, but he was forced into it; and it was not evidence of malice or of anything but acting under a pure sense of duty. In his Lordship's opinion the appeal must be allowed, the judgement below set aside, and judgement entered for the appellant (Dr. Orr) with costs in the Court of Appeal and below. Lords Justices Warrington and Atkin concurred; the latter added that in his opinion everything that took place was consistent with the appellant doing his duty. Even if there had been any feeling of hostility before the report was communicated it did not justify the finding of express malice.

The appeal was accordingly allowed, the judgement below set aside, and judgement entered for Dr. Orr, with costs of the trial and appeal.

Universities and Colleges.

UNIVERSITY OF LONDON.

A MEETING of the Senate was held on January 19th. The Prince of Wales has consented to accept the honorary degrees of Master of Commerce and Doctor of Science, which will be conferred on Presentation Day in May.

The Senate expressed gratification at the anonymous donation of £20,000 made to the Middlesex Hospital Medical School for the endowment there of the University Chair of Physiology. It was resolved to institute a University Chair of Embryology at University College and a University Chair of Physics at Bedford College. Applications for the latter post (£800 per annum) to be sent to the Academic Registrar by April 16th.

It was resolved that the regulations for the M.D. examination (Branch III, Mental Diseases and Psychology, Red Book 1920-21, p. 264, and Blue Book 1920, p. 247) be amended by the addition of the following at the end of Branch III:

In and after the examination to be held in December, 1922, the Regulations for Branch III will be as follows:

Branch III—Psychological Medicine.—Two papers in Mental Diseases and Mental Deficiency. One paper in Psychology. One paper in Neurology, which shall include the anatomy and physiology of the nervous system. An essay on one of two subjects in mental diseases or a case for commentary in mental diseases. A clinical examination.

The necessary consequential changes in the title of the M.D. examination (Branch III) are to be made in the regulations.

Sir James Barr has been reappointed Chancellor's representative on the Court of the University of Liverpool, and Dr. Russell Wells has been reappointed the representative of the University on the General Medical Council.

The University Medal in Branch VI (Tropical Medicine) of the M.D. examination, December, 1920, has been awarded to E. S. Phipson (University of Birmingham), and the University Medal in Branch I (Surgery) of the M.S. examination, December, 1920, to R. L. Horton (University College Hospital).

Applications for grants from the Dixon Fund for assisting scientific investigations must be received by the Senate between April 1st and May 15th, 1921. Applications for the University studentship in physiology must be received by the Principal Officer by May 31st. The studentship (value of £50 for one year) is tenable in a physiological laboratory of the University or a school thereof. Full regulations as to award can be obtained on application.

Essays and dissertations on hyperthyroidism and its surgical treatment, for the Rogers Prize (value £100), must reach the Vice-Chancellor by April 30th. It is open to all persons whose names appear on the *Medical Register*.

Applications for the University chair of anatomy, tenable at St. Bartholomew's Hospital Medical School (salary £900 per annum), must be received by the Academic Registrar at the University by April 14th.

UNIVERSITY OF SHEFFIELD.

THE following candidates have been approved at the examinations indicated:

D.P.H.—W. J. Fordham, G. G. Marshall.
THIRD M.B., CH.B.—Annie D. Sykes.

UNIVERSITY OF BIRMINGHAM.

THE Council of the University, in its report to be presented to the forthcoming meeting of the Court of Governors, states that so far the response to the university's appeal for £500,000 has reached £280,444, of which £135,417 has been specially allocated by the donors, leaving £145,027 for general purposes.

ROYAL COLLEGE OF PHYSICIANS OF LONDON.

AN ordinary Comitia of the Royal College of Physicians of London was held on February 3rd, when the President, Sir Norman Moore, was in the chair.

Licences to practise physic were granted to the following eighty-three candidates who had passed the necessary examinations:

*Doris E. Alcock, H. E. Alexander, G. W. Almeyda, C. H. Andrewes, H. N. Andrews, Kathleen Ardell, O. A. Baker, W. E. Barnes, H. E. Beasley, Margaret B. Best, L. M. Billingham, J. Blain, H. H. Bracewell, J. L. McK. Brown, L. Buddle, C. L. C. Burns, A. V. Cantin, Dorothy S. Chamberlain, L. C. F. Chevens, F. Christian, Ivy Collier, F. de Caux, A. H. G. Down, A. G. Duncan, T. A. Eccles, R. T. Edwards, H. Franklyn, O. P. Gallegos, G. I. Griffiths, W. R. W. Haight, H. W. Hammond, Katharine M. Harbord, H. J. H. Hendley, T. B. Hodgson, S. H. G. Humphrey, A. Y. Ibrahim, J. G. Johnstone, H. C. V. Joy, A. N. Kingsbury, F. G. Latham, Anna G. M. Lewis, C. J. Lewis, C. A. Lindup, Kathleen M. B. McArthur, W. McKenzie, Elizabeth Matthau, A. Mikhail, G. S. Mitchell, W. P. Newman, Helen O'Brien, F. R. Oliver, S. Orchard, T. L. Ormerod, *Tressila L. Pires, *Olive G. Potter, C. S. C. France, J. M. Ratray, P. I. Richardson, O. A. L. Roberts, A. el R. Roushdy, G. R. A. de M. Rudolf, H. L. Sackett, A. el R. Sami, Maud Sanderson, R. G. A. Shaw, N. L. Sheores, A. el R. Sami, Maud Sanderson, R. G. A. Shaw, N. L. Symes, A. H. Talaat, K. H. Talkern, H. E. Thomas, R. S. Thomas, N. Thomson, H. M. Toop, G. D. C. Tracy, T. W. Turner, *Madeline H. J. Umpleby, Gladys M. Wanhope, *May G. Williams, H. N. Witham, F. W. Zaglana.

*Under the Medical Act, 1876.

A letter was received from the Voluntary Hospital Committee appointed by the Ministry of Health, with Lord Cave as chairman, to inquire into the financial position of the voluntary hospitals, inviting the College to present evidence. A reply was drafted pointing out the importance of the voluntary principle in relation to the interests of the sick, medical education, and the increase of knowledge. The President and Censors were appointed as representatives of the College if evidence were desired on these points.

A report from the Committee of Management on the Conjoint Examination in Midwifery and Diseases of Women was discussed and referred back for further recommendations.

ROYAL COLLEGE OF SURGEONS OF ENGLAND.

Arris and Gale Lectures.

AN Arris and Gale Lecture, on the function of the kidneys in enlargement of the prostate gland, will be delivered in the theatre of the College, Lincoln's Inn Fields, W.C., on Friday, February 18th, at 5 p.m., by Mr. J. F. Dobson, M.S., F.R.C.S.

An Arris and Gale Lecture, on the azygos system of veins in their association with surgical affections, will be delivered in the theatre on Monday, February 21st, at 5 p.m., by Professor J. Howell Evans, M.D., M.Ch., F.R.C.S.

ROYAL COLLEGE OF PHYSICIANS OF EDINBURGH.

Parkin Prize.

IN terms of the bequest made to the College by the late Dr John Parkin, a prize, value £100, is offered for the best essay or certain subjects connected with medicine. The subject of the essay for the present period is, in terms of the deed—

"On the effects of volcanic action in the production of epidemic diseases in the animal and in the vegetable creation, and in the production of hurricanes and abnormal atmospheric vicissitudes."

The prize is open to competitors of all nations. Essays intended for competition, which must be written in the English language, must be received by the Secretary not later than December 31st, 1921. Each essay must bear a motto, and be accompanied by a sealed envelope bearing the same motto outside, and the author's name inside. The successful candidate must publish his essay at his own expense, and present a printed copy of it to the College within three months after the adjudication of the prize.

The Services.

BIRMINGHAM TERRITORIAL DINNER.

THE annual supper and smoking concert of the Royal Army Medical Corps (Territorial Units) of Birmingham was held at the White Horse Hotel on January 28th, with Lieut.-Colonel C. H. Howkins, C.B.E., D.S.O., T.D., in the chair. The A.D.M.S. of the Division, Colonel L. J. Blandford, A.M.S., C.B.E., T.D., was present, and the chairman was supported by Lieut.-Colonel R. A. Broderick, D.S.O., M.C., and Lieut.-Colonel H. F. W. Boeddicker, R.A.M.C.T.F.

The Chairman in a short speech said the great strides that had been made in recruiting for the units since the New Year and the indication there was that these units would shortly be at full peace strength. He also pointed out that the difficulties in regard to the establishment and enlistment of transport personnel having been settled, this important branch of the field ambulances should soon be in full swing. Lieut.-Colonel Broderick remarked on the great hopes there were of acquiring the use of a suitable drill hall at Sutton Coldfield, thereby creating in that district a section of the 2nd Field Ambulance, as obtained in pre-war days. Colonel Blandford expressed his appreciation of the progress made by the units in recruiting, and hoped that the social side of the Territorial Army would be kept up to the old traditions. It was a generally accepted fact that the transport sections would be just the same as in pre-war days, except that "R.A.S.C." would be substituted for "R.A.M.C." in the shoulder titles of the personnel. Major L. Ball, M.C., on behalf of Lieut.-Colonel Boeddicker, expressed his pleasure in being able to announce that a band was

in progress of formation for these units. This would no doubt be a splendid means of providing congenial entertainment for the members, both at headquarters and in camp, and would also prove a big incentive to recruiting.

About 100 members were present, and a strong programme was provided, which was thoroughly appreciated by all present.

HONOURS.

FOREIGN DECORATIONS.

The following decorations have been conferred by the King of the Belgians for distinguished services rendered during the course of the campaign:

Ordre de Leopold.—*Chevalier*: Lieut.-Colonel Robert Tibbitt Brown, C.M.G., D.S.O., R.A.M.C.; Lieut.-Colonel Edmund Philip Hewitt, R.A.M.C.

Ordre de la Couronne.—*Officier*: Colonel William Coates, C.B.E., V.D., R.A.M.C. (T.F.). *Chevalier*: Lieut.-Colonel James Fitzgerald Martin, C.M.G., C.B.E., R.A.M.C.; late temporary Captain George Arthur Skinner, R.A.M.C.

Croix de Guerre.—Lieut.-General Sir T. H. John C. Goodwin, K.C.B., C.M.G., D.S.O., K.H.S.; temporary Major Harry Compton Parsons, T.D., R.A.M.C. (T.F.); honorary Lieut.-Colonel N.Z.M.C. Reserve of Officers; Brevet Colonel Sir Edward S. Worthington, K.C.V.O., C.B., C.M.G., R.A.M.C.; Brevet Lieut.-Colonel Andrew Rao Wright, D.S.O., R.A.M.C.

DEATHS IN THE SERVICES.

COLONEL MATTHEW DANIEL O'CONNELL, A.M.S. (ret.), died at Leeds on January 22nd, aged 73. He was born at Cork on April 5th, 1847, educated at Queen's College, Cork, and graduated M.D. and M.Ch. in the Queen's University, Ireland, in 1869. Entering the army as assistant surgeon on April 1st, 1871, he became colonel on April 10th, 1901, and retired on April 5th, 1907. He served on the North West Frontier of India in the campaign of 1897-98, receiving the medal with a clasp. He was the author of a work on *Climate and Life*, 1909.

Lieut.-Colonel Thomas Henry Delany, Indian Medical Service (retired), died on October 10th, 1920, aged 50. He was educated at the Catholic University, Dublin, graduating M.B., B.Ch., and B.A.O. of the Royal University of Ireland in 1893 and M.D. in 1906. He also took the F.R.C.S. (Ire.) in 1906. He entered the I.M.S. on January 28th, 1898, became lieutenant-colonel in 1917, and retired on January 29th, 1918. He served in the China war of 1900, and received the medal; for most of his service he was employed as a civil surgeon in Bengal.

Major Richard Rutherford, R.A.M.C., died at Cheltenham on January 12th. He was the son of the late Richard Rutherford, F.R.C.V.S., was educated at Edinburgh, where he graduated as M.B. and Ch.B. in 1901, and entered the R.A.M.C. as lieutenant on September 1st, 1902, becoming major on March 1st, 1914. He served in France in the recent war, and received the 1914 star and the medals.

Medical News.

DR. ALEXANDER F. R. WOLLASTON, who was lately elected to a Fellowship at King's College, Cambridge, has been chosen as medical officer of the forthcoming Mount Everest Expedition. Dr. Wollaston was awarded the Gill Memorial Prize by the Royal Geographical Society in 1914 in recognition of his explorations in the Sndan, Ruwenzori, the Pacific, and Dutch New Guinea.

A REUNION dinner of the staff (medical officers, sisters, and V.A.D.'s) of No. 14 General Hospital (Wimereux) will be held at the Ladies' V.A.D. Club, 28, Cavendish Square, London, W., at 7.30 p.m., on Wednesday, March 16th. Lieut.-General Sir John Goodwin, K.C.B., Director-General A.M.S., will preside. Applications for tickets, price 15s. inclusive, should be made, together with remittance (postal orders, crossed "Holt and Co."), to Miss Sloggett, 6, Bickenhall Mansions, London, W.1.

As there is reason to believe that numbers of imported thermometers are being offered for sale in this country without having been officially tested, the Board of Trade point out that, under the provisions of the Clinical Thermometers Order, 1918, no person may sell, offer for sale, supply or deliver any clinical thermometers which have not been tested, approved, and marked at the National Physical Laboratory. Purchasers should, in their own interests, see that any thermometers offered to them bear the official test mark—namely, a monogram formed with the capital letters N.P.L., followed by two figures denoting the year of test. The above requirements apply to foreign thermometers imported into this country equally with those of British manufacture, but clinical thermometers exported from the United Kingdom need not at present be tested and marked.

A SPECIAL council of governors of the Great Northern Central Hospital will be held on February 16th to consider and, if thought fit, to pass a resolution approving and

giving effect to the recommendation of the Committee of Management for the absorption of the Royal Chest Hospital, City Road.

The joint meeting of the Röntgen Society with the Institution of Electrical Engineers and the Electro-Therapeutic Section of the Royal Society of Medicine has been postponed until next autumn.

At the next meeting of the Medico-Psychological Association of Great Britain and Ireland to be held on Thursday, February 24th, 1921, at 11, Chandos Street, Cavendish Square, W.1, at 2.45 p.m., Sir Frederick Mott will read, in conjunction with Dr. Hayao, a paper on the pathology of dementia præcox, especially in relation to the condition of the ovaries.

A MEETING of the Society of Superintendents of Tuberculosis Institutions will be held at 122, Harley Street, at 4 p.m., on Monday, February 14th, when the main business will be the consideration of committee reports on the co-ordination of institution statistics, the training of nurses, and the standards of medical and nursing staffs.

At a meeting of the Harvian Society on Thursday, February 17th, at 8.30 p.m., in the Town Hall, Harrow Road, Paddington, Dr. William Brown will read a paper on psycho-analysis.

THE different aspects of Einstein's theory of relativity will be described in a series of articles to be published in the special issue of *Nature* on February 17th. The contributions will form an authoritative scientific statement on relativity from various points of view.

COLONEL S. LYELL CUMMINS has vacated the post of Professor of Pathology at the Royal Army Medical College, London, and has assumed duty as Professor of Tuberculosis at University College, Cardiff.

MEMBERS of the Board of Management, the medical staff, and the governors and subscribers of St. Mary's Hospital recently made a presentation in the form of a cheque—to Mr. Thomas Ryan on his retirement from the secretaryship of the hospital after a tenure of office of more than thirty-three years.

IN a paper read before the Society of Public Analysts on February 2nd Mr. F. W. Smith, B.Sc., stated that after much practical experiment with preparations of various types of squill, the most effective squill rat poison was found to be that prepared in water from an alcoholic extract of the fresh bulb of the red squill (*Scilla maritima*). Salicylic acid could be used as a preservative of this preparation without fear of hydrolyzing the glucoside.

AN institute of biology named after Ramon y Cajal has been established at Madrid. It is to consist of four sections devoted to human and comparative histology, neurology, physiology, and experimental pathology respectively.

SOME months ago Viscount and Viscountess Cowdray presented 20, Cavendish Square, formerly occupied by Mr. Asquith, to the College of Nursing for its headquarters and for a residential club for members of the college. It has been decided that the house shall be exclusively used as a club, but that the garden, having a frontage to Henrietta Street, shall be utilized as a site for the college; to give effect to this Viscountess Cowdray has increased the gift to a total of £100,000. The club-house, it is expected, will be ready by midsummer, but the erection of the college, which will contain offices, class-rooms, and fifty bedrooms, will be deferred until building operations become cheaper.

MR. CHARLES J. HEATH, F.R.C.S., has been elected a Companion of the Institute of Marine Engineers.

LIEUT.-COLONEL WILLIAM SCATTERLY, R.A.M.C. (R.), has been appointed a Knight of Grace in the Order of St. John of Jerusalem, and Lieut.-Colonel Frederick S. Lambert, R.A.M.C. (T.F.), an Esquire.

THE second congress of the Italian Society of the History of Medical and Natural Sciences will be held at Bologna in October, 1921, under the presidency of Professor Domenico Maiocchi, who as Professor Maiocchi will read a paper on prehistoric surgery, and Professor D. Barduzzi one on the teaching of clinical medicine in the Middle Ages.

DR. DEFERRIS, Secretary of the Société Française d'Ototohino-laryngologie and an authority on hydrology, has recently died at Caudebec at the age of 65.

MESSES. GEORGE AND HENRY WILLS, who contributed large sums towards founding the University of Bristol, have given a further £200,000 to complete the building extension to the university which is being erected at their expense in memory of their father, the late Mr. H. O. Wills, the founder.

Letters, Notes, and Answers.

As, owing to printing difficulties, the JOURNAL must be sent to press earlier than hitherto, it is essential that communications intended for the current issue should be received by the first post on Tuesday, and lengthy documents on Monday.

ORIGINAL ARTICLES and LETTERS forwarded for publication are understood to be offered to the BRITISH MEDICAL JOURNAL alone unless the contrary be stated.

CORRESPONDENTS who wish notice to be taken of their communications should authenticate them with their names—of course not necessarily for publication.

AUTHORS desiring reprints of their articles published in the BRITISH MEDICAL JOURNAL are requested to communicate with the Office, 429, Strand, W.C.2, on receipt of proof.

In order to avoid delay, it is particularly requested that ALL letters on the editorial business of the JOURNAL be addressed to the Editor at the Office of the JOURNAL.

THE postal address of the BRITISH MEDICAL ASSOCIATION and BRITISH MEDICAL JOURNAL is 429, Strand, London, W.C.2. The telegraphic addresses are:

1. EDITOR of the BRITISH MEDICAL JOURNAL, *Aitiology*, Westrand, London; telephone, 2650, Gerrard.
2. FINANCIAL SECRETARY AND BUSINESS MANAGER (Advertisements, etc.), *Articulate*, Westrand, London; telephone, 2650, Gerrard.
3. MEDICAL SECRETARY, *Medisecra*, Westrand, London; telephone, 2650, Gerrard. The address of the Irish Office of the British Medical Association is 15, South Frederick Street, Dublin (telegrams: *Pacillus*, Dublin; telephone, 4737, Dublin), and of the Scottish Office, 6, Rutland Square, Edinburgh (telegrams: *Associate*, Edinburgh; telephone, 4361, Central).

QUERIES AND ANSWERS.

BRASS FEVER.

"X. X." who practises in an industrial district of Scotland, writes: In the foundry of a works with which I am connected the men suffer from a condition called by them "brass fever." Some suffer more than others, but there does not seem to be any natural or acquired immunity. It is presumably due to the fumes arising from the molten alloys. The symptoms are headache, shivering and sensation of cold all over, followed by a feeling of great heat and, after a variable time, by heavy sweats. There is then a feeling of exhaustion and "soreness all over." At the end of twenty-four to forty-eight hours convalescence is established and the man resumes work, although feeling "limp." I should be much obliged if you could refer me to any literature or other source of information on the subject.

The malady in question is well known as occurring among the brass pourers in Birmingham. There it is spoken of as "brass founder's ague," a misnomer, for it has no connexion with ague. The malady affects principally newcomers, or men who have been off work for a few days. It only lasts for a few hours, but during that period it is disconcerting. A short account of the illness is to be found in Sir Thomas Oliver's *Diseases of Occupation*, published by Methuen and Co.

INCOME TAX.

"F. L. O." was rightly assessed for two months' profit in 1919 on his own account, and subsequently was in partnership in the same year, but in another place for three months. During that three months his professional expenses exceeded his takings. This is admitted by the taxing authorities, but they do not agree to setting off that loss against the previous profit.

Section 34 of the Income Tax Act, 1918, provides *inter alia* that "where any person sustains a loss in any . . . profession . . . carried on by him in partnership . . . he may, upon giving notice in writing to the inspector within six months after the end of the year of assessment . . . apply for an adjustment of his liability by reference to the loss and to the aggregate amount of his income. . . ." We have been informed that the period of six months allowed for notice is by tacit concession extended to twelve months, and we suggest that our correspondent "apply" to the inspector and ask to be supplied with a copy of any form of declaration that may be required for a claim under Section 34, Income Tax Act, 1918.

TINNITUS AURIUM.

"M.B." writes from British Guiana, in regard to the query in the JOURNAL of November 6th, 1920, regarding the efficacy or otherwise of vaccine treatment in tinnitus aurium: I should be grateful, as a sufferer myself for some months, for any suggestion that might lead to permanent benefit. The only drug I have found to give definite, if temporary, relief, is quinine, the sulphate or the hydrochloride, but it produced arhythmia of the heart, and was therefore stopped.

Some aural surgeons, we believe, prescribe dilute hydrobromic acid in fairly large doses—say 5j in water thrice daily.

DILATED PUPILS.

DR. W. B. INGLIS POLLOCK (Glasgow) writes in reply to "C. F. R.": I had a man of 29 years of age referred to me in November, 1905, with fully dilated pupils on both sides, of ten months' duration. He gave a history of a sore on the lip, followed by a sore throat, nine years previously. The eye condition was due to nuclear paralysis of the sphincter pupillae muscle, and also partial paralysis of the accommodation. He complained of double vision, but on investigation he was found to have polyopia, due to irregular peripheral astigmatism of the lens. He was ordered mercury and potassium iodide, to be continued for some years. With suitable glasses for distance and for near work the polyopia disappeared. He returned to see me at different times during the intervening years, until in April, 1920, his doctor informed me that he had developed general paralysis and had been sent to an asylum. I would advise "C. F. R." to put his patient on mercury and potassium iodide, even if the cerebro-spinal fluid is negative to the Wassermann test. If there is paralysis of accommodation she will require careful testing for suitable lenses.

LETTERS, NOTES, ETC.

A MEDICAL RESEARCH EXHIBIT.

AT the Efficiency Exhibition, now being held at Olympia from February 10th and 26th, the Middlesex Hospital Research Department have a stand showing some of the apparatus and methods of research employed in the ordinary work of a large hospital. In this exhibit are shown, for example, the stages that a piece of tissue goes through from the preliminary fixation in formol-saline to the finished section ready for microscopical examination, and at a bench some of the lay assistants of the research departments are seen carrying out routine laboratory methods. Various bacteriological, chemical, and histological processes are demonstrated, and other exhibits include an electro-cardiograph, x-ray apparatus and pictures recording drums, a telemicroscope and apparatus for microphotography. In connexion with this exhibit two series of short public lectures are being delivered in the Conference Hall. Dr. Tuck, lecturer on chemistry in the Middlesex Hospital Medical School, deals with chemical research as a foundation stone of medicine, of industrial health, and of pharmacology; and another series is given by Professor W. S. Lazarus-Barlow on fluorescence and ultraviolet rays, on x rays and their uses, and on radium and its rays. The exhibit and the lectures are designed to stimulate public interest in research generally, and in research as applied to medicine in particular.

SUPERNUMERARY NIPPLES.

DR. F. B. SKERRETT (Maidenhead) writes: During a recent medical inspection at a secondary school a well-formed boy of 15 years presented a pair of perfectly developed supernumerary nipples, complete with areolae, about 1½ in. vertically below the site of the normal nipples. He assured me his father has the same anomaly but that his sisters are free. In the course of over 52,000 examinations of school children during the past twelve years I do not remember to have met more than one other similar case. I therefore thought it worth recording on account of its rarity and biological significance. It would be interesting to know what happens to supernumerary nipples during adolescence and pregnancy when this condition is found in females.

VACANCIES.

NOTIFICATIONS of offices vacant in universities, medical colleges, and of vacant resident and other appointments at hospitals, will be found at pages 34, 35, 38, 39, and 40 of our advertisement columns, and advertisements as to partnerships, assistantships, and locum tenencies at pages 36 and 37.

THE following appointments of certifying factory surgeons are vacant: Kings Cliffe (Northampton), Marple (Stirling), Monmouth (Monmouth), Slamannan (Cheshire).

SCALE OF CHARGES FOR ADVERTISEMENTS IN THE BRITISH MEDICAL JOURNAL.

	£	s.	d.
Six lines and under	0	9	0
Each additional line	0	1	6
Whole single column (three columns to page)	7	10	0
Half single column	3	15	0
Half page	10	0	0
Whole page	20	0	0

An average line contains six words.

All remittances by Post Office Orders must be made payable to the British Medical Association at the General Post Office, London. No responsibility will be accepted for any such remittance not so safeguarded.

Advertisements should be delivered, addressed to the Manager, 429, Strand, London, not later than the first post on Tuesday morning preceding publication, and, if not paid for at the time, should be accompanied by a reference.

NOTE.—It is against the rules of the Post Office to receive post-*restante* letters addressed either in initials or numbers.

A British Medical Association Lecture

ON

VACCINE THERAPY IN REGARD TO GENERAL PRACTICE.

BY

ALEXANDER FLEMING, F.R.C.S.,

DIRECTOR OF THE DEPARTMENT OF SYSTEMATIC BACTERIOLOGY AND ASSISTANT DIRECTOR OF THE INOCULATION DEPARTMENT, ST. MARY'S HOSPITAL.

I HAVE been practising vaccine therapy since it was in its infancy, and as time goes on I find myself more and more convinced of its efficacy, not only for the more severe cases which are to be seen at a hospital, but also and more especially for the lesser ailments which seldom appear at a hospital, but with which the practitioner has much to do.

An enormous amount of work has been done in the elucidation of the changes which take place in the animal body following the injection of a vaccine and much still remains obscure, but I confine myself to putting before you the clinical aspects of vaccine therapy in general, and to dealing with the treatment by vaccines of certain conditions, more especially those in which there have been advances made in the last few years.

DEFINITION OF A VACCINE.

A vaccine is a substance which, when injected into the animal body, induces the formation of specific antibodies.

This definition makes the term "vaccine" synonymous with the word "antigen." Originally vaccines were differentiated as being preparations of bacteria, but now various protein extracts—for example, pollen extract—are used in the same way in the treatment of disease, and there seems no reason why the term vaccine, if retained at all, should not be used in the wider sense to include all antigens. In the narrower sense, a vaccine may be defined as a standardized suspension of micro-organisms in an inert fluid.

AUTOGENOUS AND STOCK VACCINES.

An autogenous vaccine is a vaccine prepared from cultures obtained directly from the patient. A "stock vaccine" is made, not from cultures obtained from the particular patient who is being treated, but from cultures of the same type of microbe as that which is affecting him. In the preparation of a stock vaccine a considerable number of strains should be employed in order to eliminate as far as possible any small differences there may be in the individual strains.

Should a Stock Vaccine be Used or an Autogenous One be Prepared?

This is not always an easy question to answer. In practice it is frequently dealt with from the point of view of expediency. In many cases where the infecting organism is easy to cultivate and the vaccine is easy to prepare, it is less trouble to prepare an autogenous vaccine than it is to identify the organism exactly. On the other hand, the isolation of the microbe and the preparation of the vaccine is frequently a very tedious and laborious proceeding, and in such cases, if the nature of the infecting agent is obvious, then a stock vaccine is often employed and an autogenous vaccine made only if the stock vaccine fails. In connexion with this question four different classes of cases have to be considered.

Class 1.—Where the vaccine is to be used for prophylaxis.

It is clear that here we have no choice. Only stock vaccines can be used. The fact that stock vaccines have been used with such signal success in the prophylaxis of typhoid, paratyphoid, cholera, plague, and the catarrhal infections of the respiratory tract, is of the utmost importance in that it shows that it is not necessary to insist on a vaccine being made of a microbe of exactly the same parentage as the infecting microbe so long as it belongs to the same species.

Class 2.—Where the nature of the bacterial infection is known but a culture of the microbe cannot readily be obtained from the patient.

Such conditions occur in connexion with tuberculous infections or where the infection is deep-seated—for instance, in the joints or glands. In such cases, again, there is almost no choice and we have to use stock vaccines, and the results which have been obtained with these in such cases show that good immunizing responses can be induced.

Class 3.—Where, owing to the profusion of contaminating microbes, it is difficult to identify and differentiate with sufficient sharpness one microbe from another of the same morphological species.

This applies especially to chronic catarrhal conditions of the respiratory and alimentary tracts, to putrid infections of wounds, and to the erosions often associated with malignant tumours. Here only a very experienced bacteriologist will be able to make satisfactory autogenous vaccines. In some cases it is quite impossible from the examination of a single specimen to say which of the many microbes present is the infecting agent, and in almost all it is extremely difficult to say which of the many varieties of streptococci is really causing the infection and which are merely leading a saprophytic existence. It will be advisable in many such cases, therefore, for treatment, and still more for prophylaxis, to employ the polyvalent stock vaccines made from a large number of strains of the microbes in question, especially as the stock vaccine can be prepared from cases in which there is no doubt as to the nature of the infection.

Class 4.—Where the infecting microbe can easily be obtained from the patient in pure culture.

These cases are very common, and when we have to choose between an autogenous and a stock vaccine in such conditions we have to balance the possible advantage of an autogenous vaccine against the labour and expense involved in procuring it.

A stock vaccine is indicated when the infecting organism belongs to a group the members of which differ very little among themselves. Thus, in staphylococcus infections, a stock vaccine will in almost all cases give as good results as an autogenous, and in some few cases the stock vaccine will prove the more beneficial. Occasionally a strain is encountered which proves to be a bad antigen, and if such a strain is isolated from a patient and an autogenous vaccine made little benefit will be derived from its use, whereas in the same case the stock vaccine, containing, as it does, a number of strains which have proved to be good antigens, would give a good result.

With *Streptococcus pyogenes* also, which is the cause of erysipelas, cellulitis, lymphangitis and many other septic conditions, it has been shown that if an animal is immunized to one strain its serum will agglutinate to the same extent all the strains. This experimental observation is in accordance with the fact observed clinically that *Streptococcus pyogenes* vaccine is one of the most effective of the stock vaccines.

Some species of bacteria, such as pneumococci, which were formerly thought to be very homogeneous groups, have recently been split up by immunological methods into three or four subgroups, and it is essential that a stock vaccine of these organisms should contain representatives of all the groups. When this is done stock vaccines of these organisms are very effective.

In connexion with some bacteria, such as *B. proteus*, it has been found that some of the strains when injected into animals give a good immunizing response against all the different strains of the microbe, while others give immunity only to one or two strains. When dealing with such microbes it is essential that the stock vaccine should be made from strains of general antigenic power and not from strains which are merely partial antigens. If the stock vaccine is not made in this way it is better to use an autogenous vaccine.

Other organisms, such as Pfeiffer's bacillus of influenza, differ even more one from another in their antigenic powers, so that if an animal is immunized with one strain its serum will agglutinate that strain and not than a very small proportion of the other strains. In a case the stock vaccine must be made from a

* Delivered before the Maidstone Division of the British Medical Association.

number of strains to ensure a wide polyvalency. A stock vaccine of Pfeiffer's bacillus made in this way has proved extremely efficacious, but in view of the immunological differences between the different strains an autogenous vaccine should be preferable.

A stock vaccine is indicated also in acute cases where it is desired to proceed with vaccine therapy at once without waiting for the preparation of an autogenous vaccine. In such cases it may be given in small doses while the autogenous vaccine is being prepared. If this is done it will often be found that by the time the autogenous vaccine is prepared the condition will have improved to such an extent that there will be little need to use it.

It is desirable to use an autogenous vaccine (a) when the infecting agent belongs to an ill-defined group of microbes. This is well exemplified in the so-called "*B. coli* infections," for the name is loosely applied to a large group of organisms which, as regards their antigenic properties, are very different. It is therefore more satisfactory in such infections to employ an autogenous vaccine. (b) When the infection is severe and it is felt to be too great a risk to wait to see whether the stock vaccine is effective; but it is wise in such cases to give a small dose of the stock vaccine while the autogenous one is being prepared. (c) When treatment with a stock vaccine has failed.

CLINICAL EFFECTS.

The clinical effects of the injection of a bacterial vaccine may be divided into two classes: (a) toxic and (b) immunizatory.

Toxic Effects.

These follow soon after the injection and the term "reaction" is applied to them. They fall under three headings:

1. *Local Reaction.*—This is the effect produced at the site of the inoculation. It varies enormously in the same individual with different vaccines and in different individuals with the same vaccine, and the intensity of the reaction has no known bearing on the general changes occurring in the individual in response to the inoculation. It varies from nothing at all to a brawny swelling extending for some distance from the site of the inoculation. Usually it consists merely of a slight local swelling and tenderness, and causes little discomfort. Apart from this discomfort it is of no importance. The local reaction is always more severe when the injection is made in a region which is subject to pressure of the clothing, or which does not contain much subcutaneous fat, and is situated over muscles which are constantly in use (for example, the forearm). The best sites for inoculation seem to be in women about two inches below the centre of the clavicle or behind the shoulder, and in men the flank also is very suitable.

2. *Focal Reaction.*—This is the term applied to the effect of an inoculation of vaccine on the focus of infection. With a small dose there is no apparent focal reaction. With a larger dose there is some increase of the inflammatory signs in the infected focus. With a very large dose there may be a very great exacerbation of the symptoms which may result in the necrosis of the infected tissues. With the average dose there is, however, little or no focal reaction.

3. *General Reaction.*—Small doses of vaccine are not followed by any general toxic manifestations, but very large doses are apt to be followed after a few hours by signs of a general intoxication. A mild general reaction consists merely of a little malaise, but if the reaction is severe then there may be rigors, sweating, high fever, and even diarrhoea, sickness, or collapse. Doses of vaccine causing severe reactions should never be used. This general reaction is caused in part by the toxic substances which are introduced in the vaccine, but it is also probably caused largely by the absorption of toxic material from the infected focus which has at the same time been much disturbed by the focal reaction.

Immunizatory Phenomena.

1. *Focal.*—These focal changes vary so much in their character, and the time it takes for any appreciable benefit to ensue varies so much with the nature of the infection, that it is not possible to generalize further than to say that after twelve hours or longer there is a diminution in the inflammatory symptoms.

2. *General.*—Usually the first beneficial effect following the administration of a vaccine is a feeling of well-being in the patient. When small doses are used this may follow within an hour or two, and it is frequently very striking. When the patient is running a slight temperature, a small dose of vaccine administered in the morning will bring the temperature down the same evening. This fall in the temperature coincides with a rise in the antibacterial content of the blood.

It has frequently been urged that in acute cases it is of little use to give vaccines, as it takes a week or more before any result of the vaccine can be seen. As I have stated above, the beneficial result of a suitable dose of vaccine may be manifest in a few hours, and a reference to the accompanying

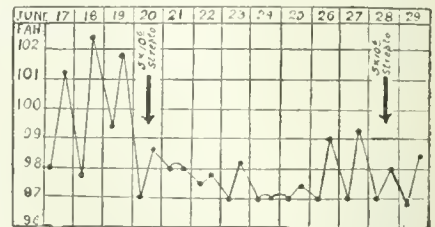

chart will show the effect of the correct dose of vaccine on the temperature chart. It will be observed that the effect of the vaccine administered about midday

was to prevent the evening rise of temperature the same day and to keep the temperature down for some days. The same effect on the temperature is seen after the second inoculation.

The patient to whom this chart refers was suffering from a septic compound fracture of the femur, and for about three weeks had had a septic type of temperature similar to that for the three days indicated in the chart previous to the inoculation.

DOSAGE OF VACCINES.

Speaking generally, the aim of the vaccine therapist is to give the maximum dose which will not give rise to a general reaction in the patient. In the consideration of the dose which is to be administered to any particular patient there are several factors which have to be taken into account. In the first place, it is a general rule that the more severe the infection the smaller should be the dose of vaccine administered. This, on the face of it, does not seem to be unreasonable, as the patient who is suffering from an acute infection is absorbing much toxic bacterial substance from the focus of infection, and if a large dose of vaccine is administered on the top of this, then it may easily constitute an overdose, and it is in just such a case that an overdose is to be avoided. Secondly, the toxicity of the particular vaccine which is going to be administered has to be considered. Some vaccines can be given in large doses, even in acute cases, without the slightest reaction, whereas with others great care must be taken in feeling one's way, otherwise an alarming reaction may occur. Thus, with *Streptococcus pyogenes* in an acute case it is well to begin with not more than two million cocci, whereas with Bordet's bacillus of whooping-cough or with Pfeiffer's bacillus of influenza very large doses can be given even in acute cases with impunity. In connexion with the dosage of vaccine, therefore, we have to consider several different classes of cases:

1. Where the infection is a chronic one, and where even if there is a small flare up it will not seriously inconvenience the patient—for example, syphilis or farunculosis. Here the dose should be rapidly increased—and by a rapid increase I mean successive increments of 50 to 100 per cent.—until there is a very marked improvement or until there is evidence that a slight overdose has been given as evidenced by an exacerbation of the local condition or by some fever or malaise after the inoculation—that is, until there is a focal or a general reaction. When there is evidence of this overdose, then the next dose should be reduced to the last one which failed to produce any "reaction," and the subsequent increases should only be gradual. If there is marked improvement before any "reaction" is evident (as is very often the case), then the same dose which has induced the improvement should be repeated several times, as evidently something approaching the optimum dose for the particular patient has been found.

2. Where the infection is a chronic one, but where it is not safe to risk any considerable exacerbation of the condition

—for example, chronic bronchitis. Here the best procedure is to give a safe dose and to increase the dose only gradually. By this means improvement will be seen without any danger of upsetting the patient. A little time may be lost in finding the most suitable dose, but in such a case this is infinitely preferable to the risk of setting up an acute infection.

3. In acute infections where it is essential that no "reaction" should be induced—for example, bronchopneumonia, erysipelas, etc. The same procedure should be adopted as in the preceding case, but the initial dose should be smaller (roughly one-quarter). In cases of this description it is wise to give very small doses and to repeat them often (every twenty-four or forty-eight hours if necessary). In all cases where with a certain dose there is definite improvement manifested, it is wise to repeat the same dose next time and possibly for several times. If, instead of doing this, the practitioner increases the dose according to a definite prearranged scale, then it is quite likely that he will rapidly increase the dose beyond the optimum and undo all the good which he has done with his first doses.

Here I should like to put in a word of caution to the practitioner against slavishly following the scale of doses which commonly accompany a vaccine from the laboratory. In many cases an autogenous vaccine is sent out from a laboratory in a series of ampoules, each ampoule containing a larger dose of the vaccine than its predecessor, and in many cases these doses are injected into the patient at intervals of a week or thereabouts without regard to the action of any one of them on the patient's condition. The scale of doses is given in all good faith by the bacteriologist, but it must be remembered that at the best this scale only represents the average dose and any individual may differ far from the average. It must be remembered, also, that in a great many laboratories, and especially in the commercial laboratories not attached to hospitals, the bacteriologist may have very little experience of the actual treatment of patients with vaccines, however skilful he may be at the isolation of bacteria and the preparation of vaccines. His opinion, therefore, as to the dosage of the vaccines is often taken only from what he has learnt from someone else, and it may be extremely fallacious.

A Successful Result with Vaccine Therapy.

When the microbes are exposed to the full effect of the antibacterial substances elaborated as a result of the injection of vaccine, then the result should be rapid and favourable. When, on the other hand, the microbes are enclosed in inflammatory tissue and in tissue where, as a result of the inflammation there is a greatly diminished blood and lymph supply, they will be partially sheltered from the antibacterial substances and the result will be much slower and less certain. Where the microbes are contained in some necrosed material such as a slough or sequestrum, it is unlikely that the antibacterial substances which may be produced will have any influence on the bacteria which are so hidden, although they may limit the infection and prevent its spread to the surrounding tissues.

It follows from this that in incipient infections a rapid success may be obtained, but where the infection is of old standing and the circulation through the infected focus has become impeded success will only be obtained after a long series of immunizing doses, while in cases where there are sloughs or collections of pus success with vaccines will only be obtained after the sloughs have been removed or the pus has been evacuated by surgical means.

When a vaccine is given for *prophylactic* purposes it is not to be expected that the immunity will be absolute. Even when an individual is highly immune he may receive such a large dose of a virulent organism that infection will result. It is doubtful whether a vaccine will ever be produced which will confer such immunity that the individual is resistant to the strongest infection. The vaccine will, however, confer immunity to a moderate infection, so that a disease like typhoid fever, instead of assuming epidemic proportions, will occur in an inoculated community only in a few individuals here and there who have either received an enormous infection or whose immunity may have been temporarily reduced by privation or other cause.

CLINICAL APPLICATION.

I now wish to discuss the vaccine treatment of some of the conditions which are common in general practice.

Catarrhal Infections of the Respiratory Tract.

I will commence with these first, because at this season of the year they are very much in evidence, and secondly, because in no conditions is the practitioner likely to achieve greater success with vaccines.

The bacteriology of the whole respiratory tract is roughly the same, and the three microbes which are most commonly in evidence in infections of this region are the pneumococcus, streptococcus, and Pfeiffer's bacillus of influenza. There are others, such as the *Micrococcus catarrhalis*, *Bacillus othryus*, Friedlander's pneumonia bacillus and staphylococcus, which are at times found, but infections with these are not so common.

In all these catarrhal infections of the respiratory tract we must bear in mind that we are all constantly being exposed to infections with one or other of these microbes as the number of carriers is legion. It was shown during the war that when there was an epidemic of cerebro-spinal meningitis—which is caused by an organism which inhabits the respiratory passages—there were among the people of the infected camps a very large number of carriers. During the influenza epidemics it was shown that in some communities more than half the population were harbouring in their respiratory passages the pneumococcus and Pfeiffer's bacillus, while it is probable that nearly all of us constantly have pathogenic streptococci in the mouth and post-nasal spaces. It is evident, therefore, that every one is being very frequently brought into contact with these microbes which are responsible for the catarrhal conditions, and there is no doubt that we have all acquired a certain amount of immunity. It is common knowledge that individuals vary enormously in their susceptibility to these infections: some people hardly ever get colds, others are constantly picking them up.

When we examine these "colds" bacteriologically we find that while some individuals (and these are in the minority) get many "colds" which are always caused by the one microbe, others (the majority) are infected by one microbe at one time and by another at another time. The same is seen in many cases of chronic bronchitis. The flora is not constant, but one microbe may be there for a time and then it will disappear and its place will be taken by another. This varying flora makes the treatment of respiratory conditions more complicated, but it has had one good effect as regards the vaccine treatment by the practitioner, and that is that it has caused the mixed polyvalent vaccines to be introduced. For routine vaccine therapy practice where many patients have to be dealt with, and where there is not the opportunity of having extensive bacteriological investigations done on each patient, these polyvalent mixed vaccines have met with very great success.

When a sputum is sent to the laboratory from a case of chronic bronchitis, often there is found a very mixed flora, and it is extremely difficult to say which is the infecting organism and which of the organisms are merely growing saprophytically. In such cases better results are very often obtained with the mixed stock vaccines than can be got with autogenous vaccines. There is no doubt that in the period before the influenza epidemic, in very many cases of chronic bronchitis, Pfeiffer's bacillus was missed in the examination of the sputum; it is not very easy to see in a stained specimen of sputum, and the methods of cultivation were very indifferent, so that in very many cases autogenous vaccines were made which did not contain this, which was probably the most important part of the infection.

The Common Cold.—The mixed stock vaccine (0.2 c.c.m.) should be given immediately the "cold" is noticed, and in a certain number of cases the attack will be aborted. Even when the cold has developed, the vaccine will generally cut short the attack, and especially the last stage, when there is a profuse mucopurulent discharge from the nose without constitutional symptoms. The vaccine also seems to prevent the infection spreading down to the bronchi. With the common cold, however, the chief value of the vaccine is in prophylaxis. In people who are susceptible to colds the anticatarrhal vaccine should be given in the

autumn in three doses—0.25, 0.5 and 1 c.cm.—and during the winter monthly doses of 1 c.cm. may be given. It has been common experience that by this means people can be kept free from colds who, without the vaccine, were having one attack after another during the winter.

Bronchitis.—The bacteriology of bronchitis is roughly the same as that of the common cold, and very often the attack begins with a cold. If the infection is simple, an autogenous vaccine may be made, but usually the mixed stock vaccine does all that is necessary. Doses of from 0.25 to 1 c.cm. of the mixed vaccine for colds or of the anti-catarth vaccine are given at intervals of from three to seven days, and after the first one or two doses the patient notices the improvement. The condition usually improves rapidly up to a point at which it gives little trouble to the patient, and when this stage has been reached, if larger doses are given monthly the infection gradually disappears.

Influenza.—By this term I mean the acute epidemic influenza and not the catarrhal conditions which are loosely called influenza by the public. During the recent epidemics vaccines have proved of very great benefit both in the prophylaxis and in the treatment of the complications of this disease. The primary cause of the infection is obscure. There are two schools: one holds that Pfeiffer's bacillus is the primary infection, and the other that the nature of the infection is yet unknown. There is not the slightest doubt, however, that Pfeiffer's bacillus, together with the pneumococcus and streptococcus, is responsible for the complications of the disease, and it is to them that the bronchopneumonia which caused the mortality was due. Exact figures as regards the influence of the vaccine on the epidemic were not easy to obtain, but a very interesting and important communication was published by Sir William Leishman, on the results in the military camps in England during the last wave of the epidemic, which showed that the incidence of the disease was reduced from 47.3 to 14.1 per 1,000 and the mortality from 2.25 to 0.12. Even allowing a very considerable margin of error, these figures are quite enough to prove that the vaccine was of enormous benefit in reducing the mortality. The vaccine which was used in these experiments was one which only contained a small dose of Pfeiffer's bacillus, and it has now been modified, so that it is more than likely that with the new vaccine the results would be even better than is shown by Sir William Leishman's figures. As regards the composition of the anti-influenza vaccine, there are many different combinations on the market containing varying proportions of the three microbes which are involved. Of these different vaccines, I think that the best combination is the one which we prepare at St. Mary's Hospital, which contains 500 million Pfeiffer's bacillus per cubic centimetre, with 1,000 million pneumococci and 100 million streptococci. The Ministry of Health vaccine contains a smaller dose, and especially a smaller dose of the pneumococcus, and is really a compromise between the old army formula and the St. Mary's Hospital formula. It has been shown, especially by Lister in South Africa, and by the American army authorities during the war, that very large doses of pneumococcus can be given with impunity and that better immunity followed these larger doses than was obtained with the smaller ones.

Treatment.—It has been the experience of many practitioners that small doses of one of the anti-influenza or anti-catarth vaccines was of very great benefit in the treatment of the bronchitis and bronchopneumonia which followed influenza. Doses of about 0.1 c.cm. of the prophylactic vaccine were given immediately and repeated in twenty-four hours if the temperature still remained high.

Pneumonia.

During recent years great advances have been made in the treatment, and more especially the prophylaxis, of pneumonia by means of vaccines.

In 1913 Sir Almroth Wright published results showing that among the natives employed on the mines in South Africa the administration of vaccines had a very definite effect in reducing the incidence of and mortality from lobar pneumonia. He also showed that vaccine given in the incubation period not infrequently aborted the attack—this latter observation proving that the administration of pneumococcus vaccine was not followed by any prolonged

negative phase such as sometimes follows typhoid vaccination. At the time that Sir Almroth Wright's observations were made it was not appreciated that pneumococci differed among themselves as regards their antigenic properties, but soon after it was shown by Dechez and Gillespie that pneumococci could, by immunological methods, be split up into several groups more or less definite. These observers found that there were three definite groups of pneumococci, and besides these there were a number of cocci which did not fall into these groups, and these they made a conglomerate group which they designated Group 4. It was shown that a vaccine of a pneumococcus of Group 1 would protect against an infection of Group 1 but not against the other groups; Group 2 vaccine would protect against Group 2 but not against Group 1, and so on. Lister, who continued Sir Almroth Wright's work in South Africa, ascertained which were the common types of pneumococci causing pneumonia on the Rand, and he prepared a mixed stock vaccine containing all the types, which he administered to the natives in large doses with wonderful effects as regards the prevention of the disease. The table given below, which is taken from Lister's work, refers to the incidence and mortality of pneumonia on one of the large mining compounds where there was a native population of something like 15,000 men, and it will be seen that whereas the incidence

Table showing the Pneumonia Returns of one of the South African Mines for the Years 1908 to 1913, also for the Experimental Period from November, 1916, to October, 1917, inclusive.

Year.	Incidence per 1,000.	Mortality per 1,000.
1908	70.71	14.17
1909	101.85	17.97
1910	153.54	28.97
1911	128.98	26.91
*1912	67.68	19.96
*1913	31.75	4.80
†1914	—	—
†1915	—	—
Experimental period, November, 1916, to October, 1917	4.67	0.86

* During these years the inoculations were carried out in accordance with the principles advocated by Sir Almroth Wright and his associates.

† No record on account of war conditions.

of pneumonia before vaccine therapy was instituted was 70 or more per 1,000, it dropped during the year when Lister was giving his vaccine consisting of mixed types of pneumococci to about 4 per 1,000. The effect on the mortality from the disease was even more striking, as this dropped from about 20 per 1,000 to 0.86. There can be no question from these figures that pneumococcus vaccine is of extreme value as a prophylactic, and if further evidence was required it is furnished in the various reports from the camps of the United States army during the war. Pneumonia was one of the great scourges of the American camps, but by the use of vaccines the incidence and mortality from this disease was much reduced.

As regards the treatment of lobar pneumonia with vaccines it is much less easy to obtain reliable figures owing to the great variations which are observed normally in the course of the disease. Wright's observation that the disease can be prevented by inoculation during the incubation period shows that large doses of the vaccine can be given with safety and without producing a negative phase, and a number of reports have been published showing that the administration of vaccine shortened the disease and hastened the crisis. It must be remembered, however, that when the lung is consolidated there is a very large amount of tissue swarming with pneumococci through which the circulation is greatly impeded, so that even if a certain amount of immunity is produced the immune bodies will have difficulty in obtaining access to the seat of infection. There seems to be no doubt that the administration of vaccine aids the resolution of the pneumonia and hastens recovery.

Whooping cough.

This disease is caused by Bordet's bacillus, but very soon after the onset there appear, just as we see in influenza, Pfeiffer's bacillus and pneumococcus. For the treatment of the disease, therefore, a mixed vaccine should be given. The technical difficulties of isolating Bordet's bacillus make it almost imperative in practice to use a stock vaccine, and such a vaccine should contain all three of the bacteria mentioned above. This vaccine is very little toxic, so that even for small children comparatively large doses (1,000 or 2,000 million) can be given, and it is well to repeat the doses every two or three days instead of at the longer periods which are common with the other vaccines.

The administration of the vaccine cuts short the attack and prevents complications.

It is for prophylactic purposes that the whooping-cough vaccine will be found of greatest value to the community. Either a simple vaccine of Bordet's bacillus may be given or a mixed vaccine of this bacillus combined with Pfeiffer's bacillus and pneumococcus. Three doses of the vaccine should be given at intervals of a week, and it has been found that in some communities of children whooping-cough has been almost wiped out by this means. I should strongly advocate prophylactic vaccination in institutions where there are aggregated together numbers of children, and also in families where one of the children has become infected.

Chronic Rheumatic Conditions.

I include under this heading rheumatoid arthritis, fibrositis, neuritis, sciatica, myositis and similar complaints. These all seem to take their origin from some chronic infection, which is usually streptococcal. The site of the infection is usually in the mouth or the intestine, and the streptococcus which is responsible is very different from the *Streptococcus pyogenes*, which is the causative agent in acute septic infections such as erysipelas or acute septicaemia; it is of very much less virulence, so that it may infect a portion of the body for years without causing more than slight inconvenience. It is because of this that infections of this type are allowed to persist, maybe, for many years, and it is often only when some serious result, such as rheumatoid arthritis, is seen that any attention is paid to the original infection. A common history of a patient with rheumatoid arthritis when she comes to the out-patient department is that she had bad teeth for years, and when she consulted her doctor she was told to have all her teeth out. This was followed by only temporary improvement, after which the arthritis progressed as before. On examination of such a patient's stools, it will in all probability be found that there is an enormous preponderance of streptococci, and more especially of streptococci of the mouth type. Doubtless the infection commenced in the mouth, but some of the streptococci which were being continually swallowed escaped destruction by the gastric juice and bile and established themselves in the intestine, where they had continued to flourish.

The effect in such cases of the administration of vaccines, either autogenous or stock, has been that in almost all there is some alleviation of the condition, and in some there is apparently complete disappearance of the disease. In some few there is apparently no benefit, which is not surprising considering the difficulty in isolating the organisms from the intestine and the multiplicity of types of streptococci found there. Considering, also, that the source of the streptococci is the intestine, which is to all intents and purposes outside the body, it must be appreciated that the course of vaccine treatment must be long, and it is seldom that recovery will take place in less than a year. Owing to the multiplicity of types of streptococci in the mouth and intestine it is frequently better to commence treatment with a mixed stock vaccine such as the anti-rheumatic vaccine which we make at St. Mary's Hospital and which contains a very large number of strains of streptococci from rheumatic patients, and only to proceed with an autogenous vaccine if the stock vaccine fails. If this is done, only comparatively seldom will an autogenous vaccine be required.

Diphtheria Carriers.

Brownlie (*Lancet*, March 27th, 1920) showed that by the administration of a vaccine the diphtheria bacilli could be

got rid of in a very much shorter time than by any other means. Out of a series of 50 consecutive and unselected cases who received the vaccine in doses of 10 to 60 millions every four days 44 were free from bacilli after three doses, and all were free after eight doses of the vaccine. If these observations are confirmed it would seem that for public health purposes this vaccine of the diphtheria bacillus would be of the greatest value.

Other Conditions Suitable for Vaccine Treatment.

Vaccine therapy is applicable to very many conditions other than those on which I have touched, but time prevents my going into these. Local tubercle, acne, staphylococcal infections such as boils and carbuncles, streptococcal infections such as erysipelas or pyorrhoea, and many others have been successfully treated, and indeed vaccine therapy in these conditions seems to furnish the only direct means of combating the infection. Many publications have been made on these matters, and I need not weary you with recital of the merits of vaccines in these conditions which have been treated in this way for many years.

In conclusion, I wish to draw attention to the fact that patients may be inoculated with bacterial products not only from without, but also introduced into their circulation by some disturbance of the infected focus. It has been shown by means of blood examinations that any such disturbance is followed by a sequence of events which are the exact counterpart of those following the administration of vaccines by hypodermic injection.

It does not matter what form the disturbance takes—whether exercise, massage, forcible movement or the active hyperaemia induced by the application of a fomentation—the result is the same, the only difference being that, whereas the light forms of disturbance reproduce the effect of a small dose of vaccine, the more severe disturbances may be followed by the same events which follow a large dose of vaccine, and to which I have alluded above under the heading of "General Reaction"—namely, malaise, fever, or even collapse.

It follows from this that in the treatment of any patient by vaccines a satisfactory conclusion is only to be arrived at if this phenomenon of auto-inoculation is considered, and in most cases it is necessary that these auto-inoculations should be diminished or abolished by keeping the infected part as much as possible at rest by splinting or some other means.

In some conditions, such as phthisis, it is very difficult to control these auto-inoculations, and it is probable that the very indifferent results which have followed the administration of tuberculin in this condition in many cases have been due to this fact.

THE SEROLOGICAL CHARACTERS OF DISEASE-PRODUCING PNEUMOCOCCI.

BY

RICHARD R. ARMSTRONG, M.D., M.R.C.P.

ERNEST HART MEMORIAL SCHOLAR, BRITISH MEDICAL ASSOCIATION (1919-1920).

(From the Bacteriological Department, St. Bartholomew's Hospital.)

RECENT investigations on several groups of micro-organisms, of which the meningococcus group may serve as an example, have proved the value of discrimination between disease-producing strains on the one hand and non-pathogenic saprophytes on the other. Such discrimination has been rendered possible by the general method of testing the agglutination reaction of a particular strain against specific serums, previously prepared by inoculation of rabbits with typical organisms from morbid lesions. By this means disease-producing micro-organisms have been gradually relegated to types.

The diversity of the clinical picture presented by pneumococcal pneumonia, the wide prevalence and severity of this disease, and the fact that the pneumococcus is a normal and usually harmless inhabitant of the upper respiratory passages, has suggested that distinct disease-producing types of the organism may exist.

Such has been shown to be the case by American workers at the Rockefeller Institute for Medical Research,¹

who have defined at least three serologically distinct types to which the great majority of pneumococci isolated from actual cases of pneumonia were found to belong; a number of strains from indifferent sources, such as saliva or nasal secretion, could not be grouped by the type serums.

Application of the American results to pneumonias occurring in this country was at once suggested, but having regard to our widely different climatic and social conditions, it did not seem sufficient to limit investigation to the typing of pneumococci by means of serums obtained from American sources only.

It was held that insufficient evidence of the relative prevalence of the three recognized American types in this country was available, nor was there proof that other types of pneumococci, as fertile originators of disease as any recognized in America, might not exist here. Further, it was considered inconvenient that the serological test should depend on the availability of serums derived exclusively from American sources. The preparation at first hand of type-agglutinating serums appeared expedient therefore, both from the standpoint of excluding the necessity for importing supplies, and also in order to obtain agglutinating serums prepared against strains of pneumococci derived from home sources. Experiments have been carried out with these objectives in view, and the results obtained will be considered under two headings:

I. The serological characters of pneumococci isolated from a variety of cases of pneumococcal infection not only of the lungs, but of the respiratory tract in general.

II. The preparation of agglutinating serums by the inoculation of rabbits with pneumococci derived from British sources.

I.—SEROLOGICAL CHARACTERS OF PATHOGENIC PNEUMOCOCCI.

1. Identification of the Pneumococcus.

The identification of each strain of pneumococcus prior to investigation by the serological test has been based on the characters described below—namely:

1. Habitat. The source—for example, sputum or lung juice; or heart's blood culture in a fatal case of pneumonia.

2. The very characteristic appearance of colonies on solid media. These are ringed or discoid in shape, and have an appearance resembling ground glass.

3. Pneumococci, particularly of pathogenic strains, show extraordinary predilection for media enriched with fresh blood. Although the addition of other body fluids (ascitic, etc.) will promote growth, the haemophilic character of the pneumococcus appears characteristic, and herein the organism differs from streptococci; the size of streptococcus colonies does not appear to be quite so much affected by the presence of blood.

4. Uniform turbidity in blood broth and ascitic broth; relative absence of chains.

5. The shape of the pneumococcus is usually a valuable guide; the presence of a capsule when growing in material obtained from body fluids is of important diagnostic value.

6. Mair's modification of the bile-solubility test has been employed.

One-tenth of a cubic centimetre of a 10 per cent. solution of sodium desoxycholate is added to a twenty-four-hours old culture in 4½ c.cm. of sugar-free broth enriched by the addition of half a cubic centimetre of ascitic fluid.

If a pneumococcus be present, the turbid culture almost immediately clarifies; on the other hand, control tests with similar cultures of *Streptococcus pyogenes*, *salivarius*, and *faecalis* are absolutely negative.

2. The Serological Test.

An epitome of the procedure employed in carrying out the serological test follows:

TECHNIQUE.

A. Preparation of the Standard Emulsion.

1. Single colony subcultures are made from first cultures of the material under investigation on—

2. Surface plates of legumin agar containing incorporated fresh human or rabbit's blood.

3. Plates are incubated at 37° C. overnight.

4. The growth is washed off in normal saline solution.

5. The suspension thus obtained is heated to 65° for half an hour.

6. Standardized to required strength—for example, 4,000 million cocci per cubic centimetre—and phenolated by the addition of 5 per cent. phenol solution requisite to produce a final concentration of 0.5 per cent. phenol.

B. Agglutination.

1. Small glass tubes 3 in. by ½ in. are arranged in racks for incubation at 55° C.

2. Required—control normal rabbit's serum, the three type serums, and suspensions of the three type cocci.

3. Dilutions of 1 in 10, 1 in 20, 1 in 40, 1 in 80 of serum, of each 0.5 c.cm. Add an equal amount of suspension to all tubes and incubate.

4. In marked cases results are easily readable within four hours, but as a routine twenty-four hours are given.

5. Agglutination when positive is generally complete in the case of typical specimens. Any supersensitiveness of coccal suspension to serum is betrayed by the control with normal serum.

For brevity and clearness results have been expressed as far as possible in the table on page 261, which summarizes the clinical features of each case, records the source from which coccus was derived, whether sputum, etc., during life or material obtained *post mortem*. The appearance of films of such material and of the primary cultures therefrom is noted, and also the serological type to which cultures from a selected single colony were found to belong.

The table of experimental results, giving the titre of each serum against the coccus examined, submitted in the full communication to the Science Committee of the British Medical Association, has been omitted from consideration of space.

It will be noted that dependence has been placed throughout on the isolation of the presumptive infecting strain of pneumococcus from sputum by culture methods. The alternative method of injection of sputum into the peritoneal cavity of a mouse and isolation of pathogenic strains by this means has not been employed, partly because it is felt that facilities for animal inoculation in this country are to a considerable extent restricted, and partly in order to ascertain how far sputal flora are representative of lung infections. That the sputum of cases of adult lobar pneumonia who acquire a massive infection of the lung is truly representative there can be no doubt; some uncertainty arises in the case of children, whose sputum, both in film and culture, differs very markedly from lobar sputum, most commonly showing a mixed flora, though usually containing pneumococci in excess. Coughing may always be induced, and a little sputum can thus be obtained, by swabbing the throat just above the upper opening of the larynx of a child suffering from bronchopneumonia.

Certain inferences appear justified from a study of the results recorded in the table.

1. The American type pneumococci are responsible for disease in this country and have a similar distribution.

2. Seeing that the Type I coccus is responsible for many typical cases of lobar pneumonia in adults, and that this infection must be widely distributed, it is remarkable that this type does not appear to cause disease in childhood. So far, the pneumococci responsible for disease in young children have been found to belong almost uniformly to Type II.

In four cases of bronchopneumonia examined *post mortem* a Type II coccus was obtained from the lungs, in the remaining eight cases from the sputum during life. From present observations it would seem that this type of coccus most frequently causes illness in children, as it has also been obtained from undoubted tissue sources—for example, empyemata or the meninges and heart's blood *post mortem*. At the same time the need for a confirmatory study of lung puncture fluid is indicated, while the sputum of normal healthy children may also repay investigation, particularly if it is found that type pneumococci are absent or relatively absent therefrom.

The passage of Type I infection from mother to child is exemplified by Cases G. and H., in which a boy, aged 12 years, developed a typical lobar pneumonia with crisis a week after his mother fell ill, her pneumonia being complicated by an empyema. On the other hand, in Cases E. and Z., a father and his son aged 4 were admitted to hospital simultaneously suffering from lobar- and bronchopneumonia respectively. A Type I coccus was isolated from the sputum of the father, a Type II from that of the child; this finding does not suggest a case-to-case infection.

In only one case, A.J., a girl aged 6 years, with empyema, has a Type I coccus been isolated from a child.

It would seem that a very different kind of susceptibility to the two types must exist in the case of children and adults, and the observed difference in the clinical aspect of pneumococcal lobar- and broncho-pneumonia is thus confirmed by the serological findings. So far as the writer is concerned this result was not anticipated.

Types of Pneumococci Occurring in Acute Infections of the Respiratory Tract.

Clinical and Serological Type.	Case Reference.	Age: Years.	Source.	Film or Culture.	Clinical and Serological Type.	Case Reference.	Age: Years.	Source.	Film or Culture.	
LOBAR PNEUMONIA. A.-H., Type I. I.-O., Type II. P., Non-agglutinator.	A.	Adult	Sputum	Dominant pneumococcus.	BRONCHOPNEUMONIA. BRONCHITIS. AF.-AH., Type II. EMPHYEMA. AL., AJ., Type I. AK.-AM., Type II. SEPTICAEMIA. AN., Type III. AO., AP., Type II. MENINGITIS. AQ.-AT., Type II. PERITONITIS. AU., Type I. UPPER RESPIRATORY PASSAGES: RHINITIS, etc. AV.-BB., Type II. BC., Non-agglutinator.	AB.	3	Sputum	<i>B. diphtheriae</i> , pneumococcus	
	B.	"	Empyema, pus	Pneumococcus.		AC.	2	"	"	Dominant pneumococcus
	C.	"	Sputum	Dominant pneumococcus.		AD.	6	"	"	Mixed flora
	D.	"	"	Dominant pneumococcus.		AE.	3½	"	"	Dominant pneumococcus
	E.	"	"	Dominant pneumococcus.		AF.	Adult	Sputum	Dominant pneumococcus	Dominant pneumococcus
	F.	"	"	Dominant pneumococcus.		AG.	"	"	"	Dominant pneumococcus
	G.	"	Empyema, pus	Pneumococcus.		AH.	"	"	"	Dominant pneumococcus
	H.	12	Sputum	Dominant pneumococcus.		AI.	Adult	Pus	Pneumococcus	Pneumococcus
	I.	Adult	Pleural exudate post mortem	Pneumococcus.		AJ.	6	"	"	"
	J.	"	Heart's blood post mortem	Pneumococcus.		AK.	Adult	Pus post mortem	"	"
	K.	"	Sputum	<i>B. influenzae</i> , pneumococcus.		AL.	6	Pus	"	"
	L.	"	"	Pure culture pneumococcus.		AM.	6	"	"	"
	M.	"	"	Dominant pneumococcus.		AN.	Child	Heart's blood post mortem	Pneumococcus	Pneumococcus
	N.	"	Empyema, pus	Pneumococcus.		AO.	1½	Pericardial fluid	"	"
O.	"	Sputum	Dominant pneumococcus.	AP.	1½	Heart's blood post mortem	"	"		
P.	"	"	Dominant pneumococcus.	AQ.	12	Pus post mortem	Pneumococcus	Pneumococcus		
BRONCHOPNEUMONIA. Q., Non-agglutinator. R.-AE., Type II.	Q.	Adult	Sputum	Friedländer's bacillus, pneumococcus.	AR.	12	"	"	"	
	R.	"	Bronchial secretion post mortem	Dominant pneumococcus.	AS.	7	Lung juice post mortem	"	"	
	S.	Child	Bronchial secretion post mortem.	Dominant pneumococcus.	AT.	Adult	Pus post mortem	"	"	
	T.	"	Empyema, pus post mortem	Pneumococcus.	AU.	Adult	Heart's blood post mortem	Pneumococcus	Pneumococcus	
	U.	"	Lung puncture fluid	Dominant pneumococcus, streptococcus, <i>B. catarrhalis</i> .	AV.	Adult	Nasal discharge	Dominant pneumococcus	Dominant pneumococcus	
	V.	7 wks.	Sputum	Dominant pneumococcus.	AW.	"	"	Dominant pneumococcus	Dominant pneumococcus	
	W.	8 mos.	"	Dominant pneumococcus.	AX.	"	"	Dominant pneumococcus	Dominant pneumococcus	
	X.	2½	"	Dominant pneumococcus.	AY.	"	Post-nasal space secretion	Dominant pneumococcus	Dominant pneumococcus	
	Y.	1½	"	Dominant pneumococcus.	AZ.	"	Pharynx	Pure pneumococcus	Pure pneumococcus	
	Z.	4	"	Mixed flora, including pneumococci.	BB.	Child	Nasal discharge	Dominant pneumococcus	Dominant pneumococcus	
	AA.	3½	"	Pure growth pneumococci.	BC.	Adult	Empyema ethmoidalis pus	Pure pneumococcus	Pure pneumococcus	

¹ Complicated by morbus cordis.
² Complicated by mitral stenosis.

³ Post-diphtheritic bronchopneumonia.
⁴ Primary focus, mastoid disease.

⁵ General tuberculosis, terminal pneumonia.
⁶ Pyopericarditis.

3. Of the other types, as already shown by American workers, Type III has a limited distribution in the upper respiratory tract in disease; it is interesting that the only specimen was derived from a mastoid abscess with pneumococcal meningitis.

4. Certain pneumococci, which there seemed every reason to believe responsible for a particular illness, did not agglutinate with the three type serums. These may possibly be referable to the heterogeneous Group IV.

Mair's modification of the bile solubility test has proved of very great value in separating off a few cocci morphologically resembling pneumococci and with similar cultural characters, but belonging to the group of salivary streptococci and on other grounds not to be regarded as belonging to the pneumococcus group.

In addition, organisms resembling pneumococci have been isolated from time to time which appear to be non-specific, although bile-soluble. Such are often exceedingly hard to emulsify from plate cultures for the purpose of testing their agglutinating properties; the explanation of this physical peculiarity is not fully understood. More than sixty strains of pneumococci have been investigated in the course of the inquiry.

II.—PREPARATION OF AGGLUTINATING SERUMS BY INOCULATION OF PNEUMOCOCCI DERIVED FROM ENGLISH SOURCES.

Living cultures of the only Type III coccus obtained (Case AN.) were unfortunately not kept, and an American Type III coccus—a stock culture obtained from Dr. St. John

Brook, Lister Institute—was utilized for the preparation of an agglutinating serum, a serum of good titre and keeping qualities being obtained from the first rabbit inoculated.

The stock Type I coccus from Dr. St. John Brook had but feeble agglutinogenic properties, but a satisfactory coccus "A" from a typical case of lobar pneumonia here has yielded good agglutinating serum. The preparation of a good Type II serum has presented very great difficulty, and caused delay and disappointment throughout the inquiry.

Of the Type II cocci investigated all are so far possessed of but feeble agglutinogenic power. Further, the wide distribution of the Type II coccus, and the variety of conditions to which pneumococci of this group give rise demands the production of a "catholic" serum of wide agglutinating scope.

Such a discovery might have been anticipated from the admittedly complex character of the Type II group. The difficulty of producing a Type II immune serum from horses has been recognized.

The principle adopted in the preparation of agglutinating serums has been the intravenous injection of standard phenolated suspensions of the selected coccus in increasing doses at intervals of forty eight hours, and throughout only a single strain has been employed for each rabbit.

By this means satisfactory serums possessed of the property of completely agglutinating their homologous coccus, and subsequently other cocci belonging to the same group in dilutions of 1 in 80 in twenty-four hours

TABLE A.

Suspension.	Normal Serum.				"M." Serum.				"A.L." Serum.				"A.O." Serum.				"T." Serum.			
	1:20	1:40	1:80	1:160	1:20	1:40	1:80	1:160	1:20	1:40	1:80	1:160	1:20	1:40	1:80	1:160	1:20	1:40	1:80	1:160
"A." T.I. control	-	-	-	-	-	-	-	-	-	-	-	-	(+)	(+)	-	-	-	-	-	-
U.S.A. III control	-	-	-	-	+	(+)	-	-	+	(+)	-	-	++	++	+	(+)	+	-	-	-
"A.L." ...	-	-	-	-	+	+	+	-	++	+	+	tr	+	+	+	(+)	++	+	+	+
"A.O." ...	-	-	-	-	(+)	(+)	tr	-	+	(+)	tr	-	+	+	+	(+)	+	-	-	-
"J." ...	-	-	-	-	+	+	(+)	(+)	+	+	(+)	-	+	+	+	+	+	+	+	+
"M." ...	-	-	-	-	+	+	(+)	-	+	(+)	tr	tr	-	-	-	-	-	-	-	-

at 55° C., were obtained in the case of a Type I strain derived from a case of typical lobar pneumonia referred to as Type I "A" and in that of the American Type III coccus from the Lister Institute.

An example of the procedure followed when preparing a rabbit, and the result, at intervals, given by its serum, may be quoted.

A young animal weighing 1,300 grams was inoculated intravenously, at intervals varying from forty-eight to seventy-two hours, with five successive doses of an emulsion in 0.5 per cent. phenolated normal saline solution, increasing from 4,000 to 16,000 million Type I "A" coccus.

On the twelfth day from the beginning of the experiment a sample of the animal's serum was titrated against a standard emulsion of the homologous coccus. Complete agglutination in twenty-four hours at 55° C. occurred in dilution 1 in 10, distinct agglutination in dilution 1 in 20, a trace in 1 in 40.

Two further injections were given, the dose rising to 20,000 million cocci. A test of the agglutinating power of the serum six days later showed complete agglutination in dilution 1 in 40, slight in 1 in 80.

Doses of 16,000 million and 20,000 million cocci were repeated, and the animal, which had gained weight throughout the experiment, was finally bled out, exactly a month from the date of first inoculation. The final titration of the serum showed complete agglutination in 1 in 80, slight agglutination in 1 in 160.

The American Type II coccus proved a failure for agglutinogenic purposes, and recourse was had to a series of Type II cocci from definite tissue sources in cases of pneumococcal infection—for example, heart's blood, empyema pus, or lung exudate *post mortem*. These cocci were referred to type by titration against an American Type II serum prepared by the Mulford Company, Philadelphia. The strains employed are derived from the cases whose cipher they bear; the clinical features of each are noted in the table on p. 261.

The Case "I" Type II serum at first feebly agglutinated American Type II coccus, but, on keeping, this action became limited to its homologous coccus.

Case "M" and Case "J" cocci were next tried but without success, the titre attained by the Case "J" serum after sixteen injections over a period of six weeks being only 1 in 10.

It was thought that the animals employed might be in themselves poor agglutinin producers, but a result similar to the above was again obtained after repeated injection. In view of this lack of success the effect of *unheated* emulsion of cocci killed by the addition of 0.5 per cent. phenol and incubation at 37° was next tried, a rapid method of five injections at intervals of forty-eight hours being employed and the animal then bled out.

The titres of the two serums obtained were respectively:

	1:10	1:20	1:40	1:80
Case AL. ...	++	++	+	(+)
Case M. ...	+	+	(+)	-

++ = Complete agglutination, clear fluid.
 + = Distinct agglutination, fluid not clear.
 (+) = Slight agglutination.
 tr = Trace only.

Encouraged by the improved titre of the "AL." serum, two other rabbits were inoculated with the Case "AO." and Case "J." cocci, as before unheated but killed by phenol.

A sample of the blood of each rabbit taken from the ear prior to bleeding out yielded a serum with the following titre in twenty-four hours:

	1:10	1:20	1:40	1:80
Case J. ...	++	++	++	++
Case AO. ...	++	++	++	++

Three days later each of the four serums was titrated against its homologous coccus and the other cocci of the group, with the result shown in Table A. Some doubt was felt as to the accuracy of the readings owing to the fact that somewhat indifferent suspensions of cocci with tendency to auto-precipitation were employed and the experiment was therefore repeated a fortnight later, with the following result:

TABLE B.

Coccus.	T.		AL.		AO.		M.	
	1:10	1:20	1:10	1:20	1:10	1:20	1:10	1:20
J. ...	(+)	tr	(+)	-	-	(+)	tr	-
AL. ...	-	-	(+)	(+)	-	(+)	+	-
AO. ...	-	-	-	-	++	+	-	-
M. ...	-	-	(+)	-	-	-	(+)	-
A. ...	(+)	tr	-	-	-	-	-	-

No agglutination with normal serum control.

Rapid deterioration of all serums had obviously occurred, the reason for which has not yet been clearly defined: these serums were necessarily discarded and two more rabbits prepared against the AL. and M. cocci.

The AL. serum agglutinated its homologous coccus in dilution 1 in 20, and was thereupon tested against a group of cocci previously typed by the Mulford II serum to confirm the reactions of this serum. The result, Table C, indicated that the AL. serum was not only a feeble agglutinator, but insufficiently "catholic" as regards the Type II group.

TABLE C.

Type II Cocci.	AL. Serum.		Normal Serum.	Type II Cocci.	AL. Serum.		Normal Serum.
	1:10	1:20			1:10	1:20	
AL. ...	+	(+)	-	AA. ...	(+)	(+)	tr
AY. ...	(+)	-	-	AB. ...	+	(+)	tr
Y. ...	-	-	-	AM. ...	(+)	tr	+*
Z. ...	+	+	+*	"B," Type I	-	-	-†

* Poor suspension. † Control.

Meanwhile it was necessary to identify the type of a number of cocci which had been collected. A small quantity of Type II serum from the Rockefeller Institute became available from the pathological department, Charing Cross Hospital, and was tested against standard emulsions to ascertain its agglutinating properties. The serum proved so active that it agglutinated not only selected Type II cocci in all dilutions up to 1 in 80, but also reacted with a Type I and Type III coccus in dilutions of 1 in 10 and 1 in 20.

This cross-agglutination was found to be eliminated by using the serum in higher dilutions only. Finally, the serum was employed with satisfactory results in dilutions of 1 in 40, 1 in 50, and 1 in 160.

The problem presented by the preparation of a Type II serum cannot at present be considered solved. There remains to discover by repeated trial a Type II coccus of good agglutinogenic power and thoroughly representative of the group. Or, failing this, to investigate further the conditions which determine the production of agglutinins against the pneumococcus in the rabbit and lead to deterioration of agglutinin in serums when kept.

In conclusion, it may be said that the Type I pneumococcus is the most clear-cut and important of all. It is responsible for many of the severest cases here, while

American investigators have shown that Type I therapeutic serum has an appreciable effect in reducing mortality from lobar pneumonia; the serums prepared from Types II and III being up to the present far less successful.

In view of this practical aspect of the observations recorded in this report, it was necessary to determine whether the English strains of Type I cocci, identical with the American type on simple agglutination, are also indistinguishable when submitted to what is perhaps the most specific test available, the *absorption of agglutinin*.

The cocci compared in this respect were Type I American, English Type I "A," Type I "B" with Type II "M" as control. The serum used was the Type I "A" prepared as described.

The experimental procedure was as follows:

1 c.c.m. of dilution 1 in 5 "A" serum was put up against equal amounts of suspensions containing 4,000 million per c.c.m. of each of the above cocci.

Conditions.—Two hours in the water-bath at 37° C. Tubes then centrifuged and the supernatant fluid titrated against the Type I "A" coccus homologous to the serum.

Absorption Experiment.—Type I "A" serum absorbed with Type I "A" coccus, Type I, U.S.A. coccus, Type I "B" coccus, Type II "M" (control) coccus.

Result after Saturation V, Type I Coccus "A."

	Dilutions.			
	1:20	1:40	1:80	1:160
Control saline...	++	++	++	(+)
Control Type II "M" ...	++	++	++	(+)
Serum saturated with Type I "A" ...	+	(+)	-	-
Type I, U.S.A. ...	+	(+)	-	-
Type I "B" ...	+	(+)	-	-

Thus while Type II "M" completely failed to reduce the Type I agglutinin, the Type I cocci all caused its reduction by about three-quarters as shown in the accompanying table. In view of this result, there is no room for doubt that the two specimens of Type I coccus isolated from cases of typical lobar pneumonia in this country are identical with the stock specimen of Type I coccus obtained from America.

With a view to preparing Type I serum for therapeutic use, cultures of the organisms isolated from English cases have been forwarded to Dr. E. G. Murray, who is working at the Field Laboratories, Cambridge, on behalf of the Medical Research Council, at the production of therapeutic serum.

Throughout the inquiry I have been constantly indebted to the active assistance, encouragement, and advice of Dr. Mervyn H. Gordon, bacteriologist to St. Bartholomew's Hospital, and of his assistant, Mr. T. Heggerty, to both of whom I express my grateful thanks.

REFERENCES.

¹ Rockefeller Institute for Medical Research, Monograph No. 7: Avery, Chickering, Cole, and Dochez, *Acute Lobar Pneumonia, Prevention and Serum Treatment*, 1917. ²W. Main, A Contribution to the Serological Classification of the Bile-Soluble Diplococci, *J. Biol. Chem.*, *xxi*, 1917.

EXOMPHALOS, OR HERNIA INTO THE UMBILICAL CORD.

BY

ROBERT TENNENT, M.B., CH.B.GLAS., F.R.C.S.ED.,
ASSISTANT SURGEON, ROYAL HOSPITAL FOR SICK CHILDREN,
AND JUNIOR ASSISTANT SURGEON, VICTORIA INFIRMARY, GLASGOW.

THE condition of exomphalos, although somewhat rare, is of considerable interest, both from the point of view of origin and that of treatment.

It may present an abnormality of such extreme degree that the greater part of the abdominal organs are contained in a sac at the umbilical attachment of the cord or near that situation; but more commonly it consists of a globular swelling of about the size of a Tangerine orange. The former extreme cases are beyond surgical aid, but the more moderate degrees are eminently suitable for operation.

The literature, although fairly copious, contains few accounts of successful surgical treatment, the reason generally being that the cases were seen, or the operation performed, too late, when either infection or obstruction with gangrene of the contents of the sac had taken place. The appended cases, illustrative of the success of immediate operation, occurred in Mr. MacLennan's wards at the Royal Hospital for Sick Children, Glasgow.

Definition.—Exomphalos has been defined by Ballantyne¹ as a true hernia of abdominal contents into the umbilical cord. It is distinct, he says, from the deformity associated with a greater defect in the abdominal wall than merely in the neighbourhood of the attachment of the cord. To this condition he gives the name *gastroschisis*. A less pronounced form of this abnormality has been described by Nicaise as "amniotic umbilicus," and consists of a deficiency of skin around the umbilicus, the deficient space being covered by amnion from the cord. In a recent article Friend² describes a case of exomphalos and prefers the name of amniotic hernia, quoting Moschcowitz³ in support of the view that the term "hernia into the cord" is a misnomer. The undermentioned cases have all been clearly of the nature of hernia into the substance of the cord, and conform to Ballantyne's definition. Accepting this definition, it might at first appear that all cases of exomphalos would be amenable to early treatment, whereas cases of *gastroschisis* are beyond relief. This, however, is not so, for some of those hernias, although having but a narrow communication with the abdominal cavity, have nevertheless contained such proportions of the abdominal, and even thoracic, organs as to render replacement impossible.

Frequency.—Exomphalos is estimated by various authors to occur in from 1 in 2,000 births to 1 in 6,000 births.

Clinical Characteristics.—The abnormality usually takes the form of a globular, asymmetrical swelling situated at the abdominal attachment of the cord and extending into its substance. Sometimes there is a constriction between the swelling and the abdomen. In such a case a serious accident might happen, as in the case described by Victor Bonney,⁴ and quoted by Friend,² where the practitioner removed the hernial sac and its intestinal contents, consisting of small intestine, during the process of ligation and division of the cord at birth. In size it varies from a walnut to a large apple, but is commonly of an intermediate size. The coverings of a light grey colour are often quite transparent, and admit of inspection of the contents of the sac. In other cases the colour is darker and the sac opaque. The covering consists of three layers, namely, amnion, Wharton's jelly, and peritoneum, the former two constituents tapering at the summit of the swelling and passing along the cord. Occasionally the skin of the abdominal wall is confined some distance on to the swelling and forms a funnel-like cup into which the swelling fits. The swelling contains usually some part of the intestinal tract and—as would be expected—not infrequently a Meckel's diverticulum. In two of the cases the caecum and appendix were found in the sac, and in both the caecum had a well-marked mesentery. Rarely can the contents be reduced into the abdomen, and more often there is obstruction to the passage of bowel contents or even a complete strangulation of bowel. If treatment is delayed one of two conditions speedily causes the death of the child: It is either intestinal obstruction, or the covering membranes are torn or slough off and peritonitis ensues the case.

Treatment.

Operation at the earliest possible moment after birth is the only successful method. This statement is apparently at variance with some textbook teaching on the subject. One author⁵ states:

"Possibly in some of the less pronounced cases a radical operation may with safety be deferred, especially if the infant has reached a few months of age."

And again:

"In certain favourable cases, where the child attains an age which will render operation justifiable, say six months or more, removal of the sac with an ligation of the edges of the gap may lead to a permanent cure."

Otherwise treatment would consist in the endeavour to prevent sepsis by appropriate dressings. Now, in the presence of the usual thin tissue-paper-like covering this is

an attainment wellnigh impossible, and in addition there is frequently the complication of obstruction. The obvious aim would appear to be the safe return of the contents to the abdomen at once. It is difficult to understand the need for postponement of operation "to a favourable age, six months or more," for all our experience goes to prove that infants stand the operation for this as well as ordinary hernia very well. This view is held by the French surgeons generally. Jaboulay and Patel,¹⁷ quoting many authors in support, urge operation at once, the danger of infection being so great. At one time, on account of bad operative results, the Germans⁶ relied on the application of an alcoholic compress bandaged firmly over the umbilicus, but this treatment is now permissible only in deformities too large for operation.

Operation consists in opening the sac, separating it from the contents, and returning the contents if healthy to the abdomen. The vessels of the cord are carefully ligated at the neck of the sac. In late cases gangrenous bowel may be met with and the outlook is hopeless. When a Meckel's diverticulum is encountered it should be removed. Occasionally there is difficulty with adhesions, and when the hernia is very large the replacement of all the contents may be exceedingly difficult. An appendicostomy¹³ can with advantage and without difficulty be done. The appendix is brought out at a small stab wound made on a piece of gauze held within the abdomen close to the anterior superior iliac spine. This is of benefit in relieving distension and in the administration of fluid by the colon in after-treatment.

ILLUSTRATIVE CASES.

Case 1.—Baby W., aged 2 days. Admitted with definite signs of intestine obstruction. There was a swelling at the base of the cord about the size of a small orange; its coverings were thin and transparent, and somewhat soiled and septic-looking; the bowel contents were clearly visible through the coverings. On opening the membrane the caecum and appendix and part of the ileum were found in the sac. They were folded over, producing complete obstruction (Fig. 1). They were returned to the abdomen and appendicostomy done as described above. The sac was removed low down, the peritoneal edges and the recti sheaths brought together with sutures and the skin sutured. Salines were given by the appendix opening and the child made a good recovery. The appendicostomy was closed at the end of fourteen days.

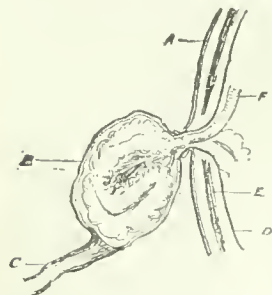

FIG. 1.—A, Skin. B, Fused layers of amnion, Wharton's jelly and peritoneum. C, Umbilical cord. D, Parietal peritoneum. E, Fibres from rectus sheath. F, Ileum. Contents: Caecum and appendix twisted on ileum.

Case 2.—Baby McC. Admitted one hour after birth, presented an irreducible swelling of the size of an orange at the base of the cord. The sac was opened and a greatly thickened and distended Meckel's diverticulum was exposed and removed. The operation was completed, as above, without appendicostomy—there being no indication for it—and the recovery was uneventful (Fig. 2).

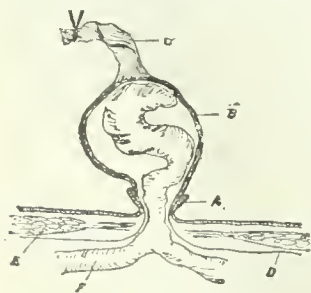

FIG. 2.—A, Skin forming funnel-like process at base of swelling (Case 2). B, Fused layers forming covering of swelling. C, Umbilical cord. D, Parietal peritoneum. E, Rectus muscle. F, Ileum. Contents: Meckel's diverticulum.

Case 3.—Baby N. Admitted, aged 1 day, with large umbilical swelling in the tissues of the cord. The coverings were opaque, but there was no doubt of the intestinal contents on examination. Operation, performed as above, revealed a sac containing the caecum and appendix; but in this case there was no obstruction of the bowel, and the sole danger lay in infection. Recovery was uneventful.

At delivery. The exposed intestines were red and inflamed, the peritoneum being obviously infected. A closed Meckel's diverticulum was adherent to the remains of the sac. Operation was undertaken, but, as was expected, death took place later. At necropsy generalized peritonitis, patent ductus arteriosus and patent foramen ovale were found.

Case 5.—Baby J., aged 4 months' illustrates an almost spontaneous cure of a small exomphalos. The child had a small rounded pedunculated swelling at the umbilicus—the so-called umbilical polypus. On removing this, a small peritoneal sac was found in the middle of it (Fig. 3). The outer layer of the swelling had become covered with epithelium from skin.



FIG. 3.—The "polypus" split in two. A, Skin. B, Wharton's jelly. C, Peritoneal sac. D, Pedicle.

Etiology.

It would appear that three main groups of factors require consideration. They are: possible antenatal conditions, developmental causes, and defects in function.

In the first group abnormality in the foetal position was thought to be the cause. Sir James Simpson⁷ stated that such cases were nearly always abdominal presentations. This lends support to another theory, that the position of lordosis in the foetus may be a cause, but the origin of such a lordosis falls into the second developmental group.

Ballantyne states that hydramnios may be a cause, and there is increasing evidence that hydramnios is a common concomitant of other foetal malformations.

Lordosis in the foetus may be caused by a pull on the omphalo-intestinal duct, and Bryce⁸ suggests that a retroflexion of the trunk of the embryo may result from defective development of the allantoic stalk and hind gut interfering with the curling of the tail end of the embryo. This view is favoured by Aschoff.⁹

An unduly short cord of itself might reasonably be a factor by causing stretching, and in extreme cases the effects of some such stretching are evident in the marked involvement and alteration of shape of the chest and solid organs. Similarly a persistent omphalo-vitelline duct may cause stretching, and it is interesting to note that one author¹⁰ states that such tension may be so marked in the embryo as to interfere with the downward growth of the rectum and hence cause impertorate anus. In this connexion it may be noted that the vitelline duct persisted in two of the four cases.

It seems unlikely that a defect in the skin development is a factor, for there was even an excess of skin in some cases. A defect in the development of the mesoblastic layer of the abdominal wall is more likely. A general enlargement of the abdominal viscera might cause a failure in the closure of the abdomen, but in none of the cases could such enlargement be made out. Moreover, a case has been recorded where the abdominal wall closed and nipped off a loop of jejunum (Ahlfeld). This loop would most likely be the normal umbilical loop of intestine, which is present in the commencement of the cord up to the third month of intrauterine life (Bolk).¹¹

This leads to a consideration of possible functional defects. Whilst the cutting off of the umbilical loop may have been due to excessively rapid development of the mesoblastic layer of the abdominal wall, the converse could equally take place. Thus, a defect in the development of mesoblast might result in a pateucy. Now, a defect in function of the mesoblast—that is, of the recti muscles—could act in the same way. This functional defect could originate in trophic, nerve or toxic irregularities. The condition is distinctly analogous to that of spina bifida, and this was long ago considered due to a dropsical condition in the foetus, producing a hernia of the meninges by interfering especially with the growth of mesoblast. This dropsy might originate in foetal heart disease, and in one of our cases there was a marked foetal heart disease. On the other hand, such cardiac weakness could conceivably arise from toxins received from a diseased maternal uterus. It was suggested in a recent review¹² of the subject of spina bifida that uterine conditions in the mother required closer investigation as possible causes of that malformation. The same applies to exomphalos, but, unfortunately, no details were got with reference to our cases.

Finally, we fall back on the trophic function, irregularity in the controlling mechanism of which may account for

almost any congenital deformity. In this connexion, Hertwig's¹² work is of great interest, for he succeeded, by applying chemical solutions to the ova of fish and amphibians, in producing many deformities, including spina bifida. A purely chemical and metabolic factor may therefore be at work.

There seems little need now for the consideration of the discontenanced amniotic band theory as a cause of any such deformity.

Conclusions.

1. The cause of exomphalos is most likely a defect in the development or function of the mesoblastic layer of the abdominal wall.

2. Treatment, to be successful, must be immediate and consists of open operation.

To my chief, Mr. Alex. MacLennan, I am indebted, not only for permission to publish these cases, but for much valued help and suggestion.

REFERENCES.

- ¹ Ballantyne, *Manual of Antenatal Pathology*. ² Friend, *Surgery, Gynecology and Obstetrics*, vol. xxxi, September, 1920. ³ Moschowitz, *Annals of Surgery*, 1915, lxi, 570-581. ⁴ Bonney, *Proc. Roy. Soc. Med.*, 1913-14, 228. ⁵ McAdam Eccles, *Textbook of Hernia*, 1908. ⁶ Abfeld, *Monats. f. Geburt. u. Gynäk.*, vol. xxiii. ⁷ Simpson, *Trans. Edinburgh Obstetrical Society*, 1886-7, xii, 33. ⁸ Bryce, quoted in *Malformations of the Foetus*, Birnbaum and Blacker, 1912. ⁹ Aschoff, *Archiv. f. Pathol.*, 1895. ¹⁰ Küstner, *Müller's Handbuch der Geburtshilfe*, 1838. ¹¹ Bolz, *Centralbl. f. Gynäk.*, 1908, p. 54. ¹² Spencer, *Med. Science, Abstracts and Reviews*, vol. i, No. 1. ¹³ MacLennan, *Clinical Journal*, August 18th, 1920. ¹⁴ Twining, *Journ. Obstet. and Gyn. of the British Empire*, 1913, xxiv, 227. ¹⁵ Twining, *BRITISH MEDICAL JOURNAL*, 1913, ii, 1159. ¹⁶ Lloyd, *Ibid.*, 1906, i, 1220. ¹⁷ Jaboulay et Patel, *Hernies*, 1903, p. 244.

THE CURE OF HAEMORRHOIDS WITHOUT OPERATION.

BY

J. C. LYTH, M.B., B.S. LOND.

I AM somewhat diffident about placing my views on this subject before the readers of the BRITISH MEDICAL JOURNAL; but it is a journal which is read chiefly by general practitioners, and it may be helpful for general practitioners sometimes to read what one of their number thinks, even though it be horesy he preaches.

My text is that operation for haemorrhoids is not always successful, is usually unnecessary, and is rarely justifiable.

I have drawn no distinction between internal and external haemorrhoids, because I think most practitioners will agree with me that such a distinction is purely artificial. Varices exist inside the anus: some are forced down in defaecation, and fail to get back before the mucous membrane covering them is gripped by the sphincter. In the first instance they are internal; after coming down they are external. If they can be returned with the aid of providence and a little coaxing, they become internal again until next time. Finally, they come down for good, and cannot be returned.

Up to a point the presence of piles outside the anus may be taken as an indication of the presence of more piles inside ready to come down. An author recently stated the limit in number of potential piles to be eight, that being the number of venous loops inside the anus. It is certainly a fairly large number, and in practice I suppose none of us have found the whole eight possible piles outside, with consequently no more piles, or possibility of piles, inside.

The critical period is when a pile is changing, or has recently changed, from inside to outside the anus. So long as it is inside and remains always inside (even during defaecation), it does little harm. When it prolapses during defaecation, and when it first comes out for good, it causes all the pain, haemorrhage, and irritation, and is liable to thrombosis and suppuration. Later, after a varying but usually considerable period, it becomes covered with squamous epithelium, and therefore insensitive, and small, and is no more than an inoffensive tag of skin, which, with reasonable cleanliness, need cause no trouble. All this may be rather crude pathology, but it is clinically. I think, a fair summary of the sequence of events.

Operation is not always successful. The usual operation removes the piles which are outside, and perhaps the more prominent of those inside. In regard to this—analogously with those of the leg—it must be remembered how remark-

ably varices may disappear under the conditions of anaesthesia and an alteration in the position of the body. Note, too, what a difference there is between the conditions of straining and prolapse of defaecation and those of the lithotomy position.

The operator at the same time puts the sphincter out of action for the time being, and gives the patient very good advice as to diet, exercise, and aperients. To my mind, if the piles do not "recur"—or, to be more accurate, if more piles do not come down—it is likely to be as much due to the advice of the operator, impressed on the patient's mind by the expense, trouble, and pain of the operation, as to anything done at the operation. The author to whom I have referred admits this, but suggests a very much more radical operation, amounting almost to a resection of the mucous membrane lining the whole canal of the anus and lower rectum. I cannot speak to the results of this, but it is not the operation for piles usually undertaken, and I have seen certainly one case of most troublesome stricture resulting from a much less sweeping operation than this.

The usual operation for piles is not a dangerous one; but it is an operation, and as such, from the point of view of the patient and the conscientious practitioner, to be avoided if possible; it is painful and it is not certain to cure.

Now for the alternative: The usual palliatives—ung. hamamelidis, ung. gallae cum opio, etc.—are no more than palliative. They to some extent relieve pain, but do little to stop the bleeding and nasty mucous discharge. I consider them only fit for use during an attack of thrombosis—after the worst has been got over with fomentations—and also if it is essential that a patient should go about his work after a recent defaecation.

But there is a means of curing piles, in the sense that they can be made entirely innocuous. It is a question of reducing from a year or two to a month or two the period necessary to change a turgid mucus-covered and tender varix into a skin-covered excrescence and preventing the piles still inside the anus from coming out.

I have seen the application of calomel powder recommended and have tried it. It is useful, but calamine powder is much more so. Calomel is a trifle irritating, but calamine is soothing and is astringent as well. But the mere instruction to apply calamine will do little good.

Suppose a bad case, with a ring of prolapsed piles surrounding the anus, some perhaps denuded of epithelium, intensely and agonizingly tender, bleeding on defaecation, and continually discharging blood-stained mucus, which stains the linen and renders the patient's life a burden. The following plan will change the picture:

1. The bowels must be moved the last thing at night before retiring. It may be difficult to alter the usual habit of morning defaecation, but it is essential, and can be contrived by suitable aperients.

2. It is hardly necessary to say the bowels must be moved every night, but a loose action must be avoided. Even a slight degree of constipation so long as a nightly action of the bowels is secured, while not so good as an easy action, is infinitely preferable to the slightest diarrhoea. This means care and discretion in the use of aperients.

3. After the motion, and after gentle sponging with tepid water, calamine powder is to be applied in the following way: it is to be freely and thickly placed (not merely sprinkled) on a sanitary wool and gauze pad. It is cheap enough, but it need not be wastefully used if care be taken that there is a sufficient quantity (say a couple of teaspoonfuls) on the exact part of the pad which will remain in contact with the piles when the tapes are tied round the waist. It is necessary that the pad should be pulled firmly up into position.

If there is much discharge the pad should be changed in the morning and fresh calamine applied. If at first there is too much discomfort during the day, it is permissible to substitute ointment for example, hamamelis—thickly applied on the pad worn during the day. But it must be explained that this is a step which somewhat retards results and does no permanent good. If the patient has the misfortune to have the bowels moved in the morning or during the day he will almost certainly have to be allowed to use ointment on the pad which he then applies, to be changed for the powder at night.

It will be found that after a time, probably not more than a fortnight or three weeks even in the bad case wo

have supposed, the piles will be sufficiently shrunken and dried and painless by the morning for the daily pad to be dispensed with, unless the misfortune alluded to occurs. Meanwhile, those of the piles normally inside, but which prolapse on defaecation, are coming into contact with the calamine before their gradual return during the night, and, subjected to its astringent action, are becoming smaller and less sensitive.

After a further lapse of two or three weeks the patient will find that, although there may be some prolapse of the internal piles on defaecation, this is so readily reduced, or reduces itself on attaining the recumbent position, that he can begin to leave off the pad at night, unless he has been either too constipated or too relaxed. He is then in a fair way to being cured. He must always have his bowels moved at night, and he is wise to have calamine and a pad available. It is, in my experience, quite futile to attempt to apply the powder in any other way than that described.

The habit of a nocturnal action of the bowels, which allows the immediate assumption for many hours of the recumbent posture, will go far to prevent any further prolapse of such piles as remain inside the anus; and I believe that in this way it will ultimately cause their reduction in size; because it is the persistence of the partial prolapse which normally occurs in defaecation which has gone far to bring them to their condition at the beginning of treatment. I assume that the haemorrhoids are not due to any direct obstruction to the portal circulation or to any local cause such as pregnancy or growth; and that exercise and limited diet will be advised.

With this alternative to operation—an alternative which is inexpensive, which entails no danger, no interference with business, and which is likely to be permanently successful—I think I am justified in my heretical proposition that operation is usually unnecessary and rarely justifiable. The remedy is almost as simple as dipping seven times in Jordan; and for that reason, doubtless, there will be those who prefer that the surgeon should "strike his hand over the place" by way of operation. Likewise, there will be the advocates of Abana and Pharpar in the shape of ointments and lotions. None the less, I hope there will be others who will emulate Naaman and decide to give this method a trial, for I have had such excellent results with it in the past three years that personally I shall advise operation only as the last resort.

RESECTION OF INTESTINE FOR ACUTE INTUSSUSCEPTION: TWO CASES OF RECOVERY.

BY

A. H. SOUTHAM, M.A., M.Ch.Oxon., F.R.C.S.Eng.,
RESIDENT SURGICAL OFFICER, MANCHESTER ROYAL INFIRMARY;

AND

C. H. CRAWSHAW, B.Ch.Camb., F.R.C.S.Eng.,
LATE ASSISTANT RESIDENT SURGICAL OFFICER, MANCHESTER ROYAL
INFIRMARY.

THE published results of enterectomy in cases of acute intussusception in infants show such a high mortality that the following cases, each of a rather unusual type, may be of interest.

Rowlands and Turner¹ quote Gibson, who says that in his collection of 1,000 cases he found only one case of recovery after resection for this condition. In an earlier collection of 239 cases there was no recovery from irreducible intussusception in a patient under seven years. Moynihan² quotes A. E. J. Barker, who says he had never seen a recovery after resection in a gangrenous case, and never expected to see it. Fagge³ reported 5 cases that were irreducible and all were fatal.

CASE I.

John C., aged 3 years, was admitted to the Manchester Royal Infirmary on December 11th, 1919. His mother stated that he had not been well for a week. He had been vomiting continually, and his bowels had not been moved for five or six days. No blood had been passed as far as she knew. The child looked ill, the temperature was subnormal and the pulse 130. The abdomen was very distended, and no tumour was palpable. On rectal examination a little blood and mucus remained on the finger-stall.

A diagnosis of intussusception was made, and laparotomy immediately carried out. Owing to the child's poor condition,

Mr. K. B. Pinson kindly gave gas and oxygen anaesthesia. The abdomen was opened by a right rectus incision, and a tumour, extending to the splenic flexure, was discovered. This was reduced easily at first by expression. After the gut had been reduced through the ileo-caecal valve, it was seen to be a double intussusception, an ileo-caecal being superimposed upon an enteric intussusception. The terminal portion of the ileum was found to be in a bad condition; it was irreducible, and there were several gangrenous patches which had perforated during the attempt at reduction. It was therefore decided to resect this portion of the ileum. This was rapidly carried out, and an end-to-end anastomosis performed between the cut ends, two layers of linen thread being used for the suture line. The portion of gut excised measured 10 in., and there were five gangrenous patches involving all the coats present. The abdominal wall was closed with through-and-through sutures of silkworm gut. The operation lasted twenty-five minutes.

Post-anaesthetic vomiting was completely absent and the child was able to take fluids immediately, shock being very little in evidence. The bowels moved the following day and each day subsequently.

Apart from a little sepsis in the wound the child made an uninterrupted recovery, and was discharged from hospital on January 13th, 1920. We have seen the boy several times since; he is in excellent health, and has had no further abdominal trouble.

CASE II.

M. R., aged 6 months, was admitted to the Manchester Royal Infirmary on December 13th, 1919. She was thin, cold, clammy and collapsed; about 7 in. of intestine carefully wrapped in newspaper protruded from the anus. The diagnosis from prolapse was not difficult, and there had been symptoms of intussusception for about twelve hours before the intestine had appeared externally.

When first seen the last two or three inches of protruded gut were very oedematous, dark purple and gangrenous. The swelling caused by the oedema quite prevented the gut from being returned through the anus, consequently the only procedure possible was to resect the intestine externally and push back the stump. This was done in the manner often known as Jessett's operation, with this difference, there being no ensheathing layer, the time usually occupied in opening and closing this was saved and the operation simplified.

The gut was pulled out still further and clamped in the healthy part thus made accessible, about 2 in. from the anus and about 7 in. from the gangrenous apex. The part distal to the clamp was now removed one inch from the clamp, and the entering (inner) layer of the intussusception sutured with continuous thread to the encircling returning layer. Only one row of sutures was applied, taking up all the coats of intestine. Some difficulty was experienced with the mesentery which was between the two layers, and made a large thick mass, and also with the disparity between the diameters of the two concentric circles of intestine. The stump was now easily reducible through the anus, and was kept in position for twelve hours by a pad of gauze on a large rubber tube in the anal canal and held there by a perineal bandage. No anaesthetic was used, the patient being practically moribund and quite motionless throughout the operation.

The point of anastomosis could afterwards be felt high up on the left side with the finger in the rectum, but there was no tendency to a recurrence of the condition. There was no post-operative vomiting, fluids were administered at once and recovery was quite uneventful. The child was seen five months afterwards; she was then quite fat and apparently in perfect health.

On examination of the part removed, the ileo-caecal valve and appendix were found at the apex—that is, the intussusception was of the ileo-caecal type. About 6 in. of intussusception were resected, which corresponded roughly to the whole of the caecum, ascending colon and part of the transverse colon, with an equivalent length of included small intestine.

In both these cases the intestine was gangrenous, and an extensive resection was necessary, but complete and uneventful recoveries followed.

The successful issue was, we consider, to a great extent due to the measures taken to safeguard the patient from the effects of shock. We suggest that shock can be considerably reduced, and the outlook therefore improved, by the following expedients:

1. *Speed* in operating is essential. Everything should be ready to hand, and the closure of the laparotomy wound should be carried out by through-and-through sutures. Suture in layers is unnecessary and expensive in time.
2. The *body heat* should be preserved by bandaging the child in a suit of gannce and the theatre maintained as warm as possible.
3. The *anaesthetic* appears closely related to the amount of shock present. In one of our cases this was minimized by using gas and oxygen, whilst in the other no anaesthetic was used.

Shock further depends on the *water-starvation* resulting from the previous vomiting and loss of fluid. In both the

above cases post-anaesthetic vomiting was entirely absent, and fluids were given and retained immediately the operation was completed. The body nutrition therefore recommenced at the earliest possible moment.

The chief difference between these two cases was that in one the abdomen was opened, whilst in the other it was not. It is suggested that the shock consequent upon opening the abdomen may be considerably reduced by employing the above methods, and the prognosis, therefore, proportionately improved.

REFERENCES.

- ¹ Rowland and Turner, *Operations of Surgery*, 1915, vol. ii, p. 545.
² Mornihan, *Abdominal Operations*, vol. ii, p. 126.

COMPLETE HEART-BLOCK IN A CASE OF DIPHTHERIA.

BY

R. CLAYTON ALLEN, M.R.C.S., L.R.C.P., D.P.H.

This case, admitted under my care in the Belper Isolation Hospital, was apparently doing quite well, until the seventh day of disease, when heart-block suddenly developed.

The notes are as follows:

M. L., a girl aged 17 years, was admitted to the hospital on September 1st, 1920. She was taken ill on August 29th with a feeling of malaise and a sore throat, and the following day was seen by her doctor, who administered 4,000 units of antitoxin, followed by a further 2,000 on the following day. On admission to hospital the tonsils and uvula were seen to be covered with membrane, and the neck was much swollen. Temperature 102.6°, respirations 28, pulse 120; slight difficulty in swallowing and face very flushed; heart regular and no cardiac dilatation. Brandy ½ oz. was given four-hourly; the throat was swabbed and sprayed two-hourly, and hot fomentations applied to the neck. Patient rapidly improved, and on the morning of September 3rd was very comfortable. Temperature 99°, respirations 20, pulse 95, when brandy was stopped; the improvement continued until 5 p.m. the following day, when the patient suddenly had a "convulsion"; marked cyanosis, and pulse became imperceptible; temperature subnormal. Brandy ½ oz. was given and oxygen administered.

I saw the patient about 5.30 p.m., when she was breathing quietly; respirations 26, slight cyanosis; pulse 26, temperature 95.6°. There was no cardiac dilatation, and on auscultation the ventricle could be heard beating 26 per minute, whilst over the auricles could be heard muffled sounds—52 per minute. Lig. strychn. nrv was ordered four-hourly, and brandy ½ oz. four-hourly; oxygen to be administered five minutes every quarter of an hour, and a mustard plaster placed over cardiac region. I saw the patient again at 8.30 p.m., when she seemed quite comfortable; still cyanosed, and the heart in the same condition as before. I saw her again at 11 p.m. in consultation with Dr. Barber of Derby.

About 1 a.m. on September 5th she had another slight convulsion, after which the patient slept until 7 a.m., when the pulse was 56, temperature 97°, respirations 18. At 10 a.m. she had a further convulsion and became more cyanosed; temperature 97°, pulse 22, respirations 18. The oxygen was still continued, and 1 c.cm. of pituitrin was administered subcutaneously.

During the day the patient did not improve, took nourishment badly, and had incontinence of urine. A further cubic centimetre of pituitrin given at 2 p.m. The patient remained listless until 8.45 a.m. September 6th, when she vomited; this was followed by a convulsion. Temperature 96.8°, respirations 16; pulse imperceptible, but the ventricle could be heard 22 per minute, and the patient complained of acute pain over the cardiac region. Death took place at 11.20 a.m. The urine showed a marked cloud of albumin the whole time the patient was in hospital.

Note by DR. HUGH BARBER.

Myocardial poisoning is a common event in diphtheria, and may be accepted without doubt as the cause of death in this case, but from the clinical point of view it was an unusual form of heart failure.

When seen by both of us together there was little distress, the radial pulse was strong and regular, 26 beats to the minute; the heart was not dilated, the cardiac impulse was vigorous, rate 26, with clear normal sounds. Over the base of the heart muffled sounds could be heard suggesting auricular beats twice as rapid as the ventricular. It was not possible to take a jugular tracing to prove the diagnosis, but complete heart-block due to poisoning of the auriculo-ventricular bundle may, we think, be taken for granted. The case presented unusual difficulties both in treatment and prognosis.

Memoranda:

MEDICAL. SURGICAL. OBSTETRICAL.

TORSION OF THE TESTIS IN AN INFANT.

The infant was born on February 13th, 1920, and on the 18th the nurse noticed some swelling of the right side of the scrotum. This swelling increased, and on February 21st I saw the infant with Dr. L. Gifford Nash of Turvey, Beds. There was no pain, and the baby seemed quite well, and was taking his food. The right side of the scrotum was swollen, the skin was blue, and the superficial veins dilated. The skin was adherent to the testis, which was much swollen and tender. The cord was thickened as high as the external ring, where there appeared to be a small nodule or swelling. I diagnosed a torsion of the testis and cord, and advised operation, which was performed on February 22nd.

An incision was made into the inflamed tissues of the scrotum, the separate layers of which were indistinguishable, until the cavity of the tunica vaginalis was reached and a thick yellow fluid gushed out. The testicle, purple in colour, appeared lying at the bottom of the tunica vaginalis. The cord was tied high up in the scrotum and the testis removed. No definite torsion of the cord was seen, but it was not exposed as high as the external abdominal ring. The infant made a good recovery.

The specimen removed was sent to Dr. S. G. Shattock, at the Royal College of Surgeons, who reported: "There is intense congestion of the tunica vaginalis and tunica albuginea. On dividing the testis there are seen superficial extravasations in its substance. I think that your first impression—namely, that the condition was caused by torsion—is correct."

Since I first reported a case of torsion of the testis (*BRITISH MEDICAL JOURNAL*, 1891, vol. i, p. 1226) many cases have been reported. A few cases have been recorded in infants. The earliest on record is that reported by Taylor (*BRITISH MEDICAL JOURNAL*, 1897, vol. i, p. 458), which was operated on at the age of two days. Rigby and Howard (*Lancet*, May 25th, 1907) reported one at seven months. Edington (*Lancet*, June 25th, 1904) also reported one at seven months. Dowden (*Scottish Med. and Surg. Journ.*, September, 1901) reported cases at five and fourteen months. Including the present case six have been recorded within fourteen months, which appears to be an unusual proportion. These cases show the liability of torsion occurring in infants, and that it is probably the only cause of acute inflammatory swelling in the scrotum in early life.

Bedford.

W. GIFFORD NASH, F.R.C.S.

TREATMENT OF LOCAL LEISHMANIASIS.

WITH regard to recent discussions on the best local treatment for local leishmaniasis (Delhi sores, Baghdad boils), I should like to mention the treatment suggested by Surgeon-General Patterson, when Principal Medical Officer of the Aldershot District, to me, when I was in charge of the surgical wards of the Cambridge Hospital, Aldershot. A soldier had recently returned from India suffering from an intractable form of Delhi sore on the left wrist, which I had treated by scraping away the granulation tissue, followed by applications of solid silver nitrate, but with little progress as to healing. The treatment recommended to me was to scrape and clean the sore again thoroughly, and lightly apply solid caustic potash and dress. After one application the granulation tissue came away, and the sore healed as a clean healthy ulcer, and there was no return, either local or general. I gather that our present treatments are not satisfactory. I therefore put forward this method for trial by specialists and others.

E. J. ERSKINE RISK, Col. A.M.S. (ret.).

F. C. Col. and Int. R.A.M.C. College.

London.

IN Java 553 cases of plague occurred last December, all of which were fatal.

PROFESSOR J. LÉPINE has been elected Dean of the Lyons Faculty of Medicine in succession to Dr. Hugonin.

DR. PHILRE BAZY has been elected member of the section of Medicine and Surgery of the Académie des sciences in place of the late Professor Guyon.

Reports of Societies.

EXOPHTHALMIC GOITRE.

A COMBINED meeting of the Clinical Section of the Royal Society of Medicine with the Sections of Medicine and Surgery was held on February 11th, for a general discussion on Graves's disease. Sir ANTHONY BOWLEY, President of the Clinical Section, took the chair, and the attendance was so large that the usual meeting room had to be exchanged at the last moment for the Barnes Hall, which was crowded out. About twenty members of the Sections signified their desire to participate, and after the discussion had been opened on both the surgical and medical sides, it was adjourned to February 25th.

Surgical Treatment: Indications and Contraindications.

Dr. HECTOR MACKENZIE said that in former discussions he had expressed scepticism with regard to surgical treatment of exophthalmic goitre, believing operation to be attended with undue risk. Ten years ago, at a similar discussion, a paper was contributed by Mr. T. P. Dunhill, of Melbourne, who reported results of surgical treatment so much superior to anything the speaker had seen in this country that he had grave doubts whether the cases were of the same class. These operations in Australia had been done under local anaesthesia, whereas all the cases of which he had personal experience were done under general anaesthesia. In 1915 he had under his care a patient who, after eighteen months' treatment, showed no obvious improvement. Mr. Dunhill, who had come over with the Australian Expeditionary Force, was consulted, and did partial thyroidectomy under local anaesthesia. The operation passed off perfectly: when it was half-way through the patient asked when it was going to begin! The effects of the operation were immediate, and the patient was better in every way. A colleague at St. Thomas's, the late Mr. Rouquette, was initiated into Mr. Dunhill's technique, and performed a number of operations, and since his death the work had been carried on by Mr. Romanis, who had performed over 200 operations, with only five deaths—a remarkable result when it was remembered that these were not cases selected as specially favourable. At the time his article on exophthalmic goitre appeared in Allbutt and Rolleston's *System of Medicine* (1908) the mortality at operation was given as 20 per cent. The effects of the operation depended to a great extent upon the amount of gland which the surgeon was able to remove. Some cases had required more than one operation.

The first case of the series which started in 1915 required three operations: in the first the right lobe was removed; in the second, fifteen months later, the greater part of the left lobe was removed; and in the third, eleven months later still, two-thirds of the remaining portion of the left lobe was removed. The result after the third operation was entirely satisfactory. The heart quietened down, and, although the eyes were still prominent, the frightened look had disappeared, and the patient had since won two first prizes for pianoforte playing, and showed no nervousness when playing in public.

The usual result following partial thyroidectomy was greater tranquillity, an increase of the general strength, and a slowing of the heart's action. Usually, when only one lobe was removed, amelioration was all that could be hoped for, though the prospects were much better than they would have been without an operation at all. The exophthalmos was the most persistent symptom.

With regard to contraindications (Dr. Mackenzie continued), auricular fibrillation might be thought to contraindicate operation, but he had seen cases operated on in which this had been present, and the result of such operation was that the heart became quieter and more regular. He had ventured an operation also in a case in which the patient was bordering on mental derangement, and her delusions disappeared. The presence of undoubted diabetes would certainly contraindicate, but he did not think that the occasional presence of sugar in the urine would militate against operation. Dread of the operation was perhaps the most important contraindication; he would be very unwilling to advise operation on any patient who dreaded it much. On the whole question his feeling was that every patient should have a fair trial of medical treatment, and if she did not

improve within a reasonable time—three or six months—the possible benefits of surgical treatment should be mentioned to her. In thirty of his private cases which had been operated on the average duration of symptoms before operation was four and a half years, so that no one could accuse him of rushing into operation. The results of medical treatment were disappointing in many cases, while, as for x-ray treatment, for a considerable number of years he saw no cases which he could regard as cured by x-rays. At last one patient who had been coming to the x-ray department for three years appeared to be cured of the exophthalmic goitre, but developed myxoedema, which yielded to thyroid treatment, and this patient then showed as good a cure as he had seen in any case. No treatment was ideal; the ideal treatment would be the provision of some antidote to the thyroid poisoning.

Operation: Conditions and Technique.

Mr. JAMES BERRY said that although his own views regarding the value of operation had not changed substantially, he was rather less sanguine than before, owing to the great tendency to relapses even after operations most successfully performed. He congratulated Dr. Mackenzie on his "conversion." There was a time when both Dr. Mackenzie and himself were strongly opposed to all operations for exophthalmic goitre. His own "conversion" was of long standing, Dr. Mackenzie's was more recent, but the tardy convert often became the most zealous apostle. On the general question he had two remarks to make: (1) The result of operation was that within a very short time—generally a few days—the patient felt that she had derived immense benefit from the operation; the feeling of depression disappeared, and the tachycardia diminished very greatly and might disappear completely in a few weeks. (2) The operation, even when carried out under the best conditions, involved considerable danger to life—a danger far greater than in operations for simple goitre. The mortality in this latter condition had been reduced by most masters of thyroid surgery to a fraction of 1 per cent., but the operation for the removal of true exophthalmic goitre generally involved a mortality of at least 3 to 5 per cent. At the same time, too much stress must not be laid upon mortality. The disease was a very serious one, and a mortality even of 5 per cent. was a risk which most patients suffering severely from this disease would willingly undertake. In speaking of exophthalmic goitre they did not always mean the same thing. At least three different conditions were included in that term. In one of these, which he called false exophthalmic goitre, the patient had an ordinary simple goitre, with a little tremor, a little nervousness, and no exophthalmos. He would not dream of putting such cases into his statistics, though they were commonly called exophthalmic. The mortality here was not in the least above that of ordinary goitre. In another condition there was an adenoma—a tumour very likely of long duration—to which all the symptoms of exophthalmic goitre had been superadded. Thirdly, there was the true exophthalmic goitre with the well known symptoms.

In Mr. Berry's view, only two operations had any value—namely, the removal of a portion of thyroid gland and ligation of the thyroid arteries. The ligation of the inferior artery he had completely abandoned; it was a difficult operation, and of scarcely less danger than the removal of the whole lobe, which was far more likely to cure the disease. The ligation of the superior artery was comparatively easy, and, on the whole, safe. He had not lost a case for eight years, during which time he had performed a large number of these operations.

His hospital cases from 1913 to 1919 where ligation of the superior thyroid artery was done numbered 27 females and one male. The particulars were as follows:

Bilateral (simultaneous)	5 cases
Bilateral (at different times)	14 "
Unilateral	9 "

Nine of these 28 subsequently underwent extirpation of one lobe.

In the removal of the gland the question arose as to how much should be removed. He had almost abandoned the practice of removing both lobes; it involved too much risk. Nor did he usually remove the whole of one lobe. It was wrong to do thyroidectomy when the patient was suffering from acute excitement, yet it was just during the

period of exacerbation that the patient, and sometimes the general practitioner, were most anxious for operation. The surgeon should resist the temptation to operate at such a time. Operation should never be performed until the patient had been resting quietly in hospital for at least a few days. He did not operate at any stage on patients who were steadily improving, nor on patients—and there were many such—who did not feel at all ill. He was coming more and more to believe that a very light open ether anaesthesia was preferable for most cases. Except where there was acute intoxication or myocardial degeneration it was usually haemorrhage that was the cause of death in operations for exophthalmic goitre. Even a comparatively small amount of haemorrhage, which would be of little or no importance in goitre, might easily be fatal in exophthalmic goitre. The after-treatment might be summed up in the one word "water." The patient should be encouraged to drink many pints.

Mr. Berry gave the following statistics of his results after the removal of true exophthalmic goitre during the years 1913-19:

Patients practically well	53
Much improved	18
Improved	1
No improvement	2
Worse	1
Died after operation... ..	3

The Justifiability of Surgical Risk.

Mr. T. P. DUNHILL dealt with the grounds on which, he considered, some intervention other than the purely medical might be necessary. Death, he said, was not the only tragedy in exophthalmic goitre. An eye might be lost; many cases also went on to a generalized oedema. Treatment other than medical, therefore, must at least be considered. All would admit that many cases recovered under medical treatment. When it was found out which cases recovered, and why they recovered, a great advance would be made. The idea of operation should not be entertained until after the removal of any toxic focus, complete rest, and systematic drug treatment. His personal experience of x-ray treatment had not been satisfactory. The pulse did not come down, the exophthalmos did not alter, and the tremors did not disappear. What was the outlook for patients who were not improving under medical treatment? Was it sufficient for medical men to claim that at least they had kept them alive? It was said that the disease ended either in recovery, myxoedema, or death. Some recovered certainly, very few went on to myxoedema: what about the others? Numbers of them were in various grades of ill health, down to being bedridden wrecks. It was justifiable to take some risk to free these patients from the miserable existence they led. As for the amount of relief which might be expected, the exophthalmos would generally disappear if the cases were sent for operation within a reasonable time, and if sufficient gland tissue was removed. In the strongly marked cases resistant to medical treatment, putting the word "cure" on one side, he would say that after operation these patients might be raised to the industrial level. A great many cases would not be cured without removal of a portion of the second lobe. He had never yet lost a patient after a second operation for exophthalmic goitre. In some cases the removal of one lobe might turn the scale, particularly cases which were nearly winning their own battle, but these were not usually the cases which came to the surgeon. It was very important to conserve the blood supply of the portion which was left intact. The thyroid operation in exophthalmic goitre differed from abdominal operations, which might be undertaken by the surgeon with some equanimity, and in which it was not a matter of great importance whether the time taken was twenty minutes or an hour and a half. The operation for exophthalmic goitre had never been done by him without fear and grave anxiety, even in cases which seemed simple. He pleaded for earlier operation, which would be safer and would relieve the strain on patient and surgeon alike.

The Natural History of the Disease.

Sir W. HALE-WHITE said that he had to admit that there was no specific medical treatment: the treatment was symptomatic. But he thought it might interest the Sections if he gave an account of the natural history of the disease. He had lately been trying to obtain particulars regarding all his hospital and private patients

during the last twenty years. A number were untraceable, but he got replies regarding 102, and he submitted his figures to an actuary to discover whether the expectation of life in people with exophthalmic goitre was much less than in normal individuals. The actuary replied that the figures were not sufficient data for a very definite opinion, but, roughly speaking, it appeared that the mortality among the sufferers from exophthalmic goitre was double that among healthy females of the same age. That gave rather an exaggerated view of the situation, because these people were young adults among whom, in health, the mortality was very slight, so that even double this mortality would not be a great mortality. It had to be remembered also that all these were cases of exophthalmic goitre which were bad enough either to go to hospital or to be sent by their doctor for a second opinion. He thought it might be concluded that the outlook for sufferers from exophthalmic goitre was that they were rather more liable to die than healthy people of the same age. This conclusion seemed justified by the fact that it was quite unusual to find the disease in the *post-mortem* room. The disease rarely killed, and, left to themselves, the people must generally get well, otherwise many people in old age would be found suffering from this condition, and such was not the case. Among the hospital cases which he had traced, 65 per cent. were found to have got quite well, 30 per cent. were much better, and 5 per cent. were better in some respect or other. Among the private cases the proportions were 74.5 per cent., 19.1 per cent., and 6.4 per cent. respectively. He had excluded from these figures the patients on whom operations had been done. There were cases in which he would willingly ask the surgeon to operate because they seemed to be going downhill, yet they might take a turn for the better without operation. He had notes of cases discharged from hospital as incurable many years ago in which, some time after discharge, a certain improvement began, and they were now quite well. He was not opposed to operation, but he thought that many cases would do quite well without it. All that they could do at present was to say to the sufferer, "We have been watching you for weeks or months (as the case might be); you are not getting any better, but at any time the natural history of your complaint seems to show that you may take a good turn. Nevertheless, we can offer you an operation with a mortality—diminishing as years go on—of, at present, from 3 to 5 per cent."

The Reason for Heart Failure.

Dr. J. S. GOODALL said that on beginning to study this condition he was soon impressed by the fact that, whether the case was looked at from the medical or the surgical standpoint, the heart was of supreme importance. A large number of the cases which were treated by physicians appeared to get gradual cardiac failure, while a certain number treated by surgeons died suddenly from the same cause. He commenced an investigation into the condition of the heart in this disease. He was particularly fortunate, because at the time he began this study he had at his disposal what he might term a clinical unit—an assembly in a nursing home of the most modern appliances for examining the heart: a four-stringed oscillograph, a two-stringed electro-cardiograph, an instantaneous x-ray apparatus, and a biochemical laboratory. Many hundreds of observations were made before the war came to upset some, though not all, of the arrangements. Ventricular fibrillation appeared to be the reason why these exophthalmic goitre cases succumbed to heart failure after operation, and the conclusion he arrived at from a study of his records was that there were two factors which tended to ventricular fibrillation, one of them a pre-existing myocardial degeneration and the other a high blood pressure. He believed that the blood pressure in exophthalmic goitre was triphasic: first a temporary rise, very transient, then a fall, and then a rise again. After operation the blood pressure tended to rise, and that rise might be so considerable that the blood pressure at the end of the operation was twice the pressure at the start. If there was a degenerated myocardium and it was suddenly confronted with a high blood pressure it was reasonable to expect calamity. If the myocardium was degenerated and the blood pressure high the surgical risk was very great.

PAROTID TUMOURS.

At a meeting of the Pathological Section of the Liverpool Medical Institution held on January 20th, with the President, Dr. J. E. GEMMELL, in the chair, after the various specimens were demonstrated and described, Mr. ROBERT KENNON read a paper on tumours of the parotid gland. The material upon which the paper was based consisted of 124 cases of parotid tumour operated upon at the Royal Infirmary, together with pathological reports and slides obtained from Professor E. E. Glynn and the private collections of Mr. Parker, Mr. Paul, and Mr. Thelwall Thomas. On analysis 91 cases were adenomata, 27 carcinomata, 6 sarcomata.

Of the adenomata, in 38 cases the after-histories had been obtained. Out of 32 cases 22 were alive and well, the average duration of each case being eleven years, while another case had died without recurrence seven years after operation; 5 had had recurrence. The tumour was most frequent in females; the average age at onset was 30 years, at operation 37 years—a delay of seven years before surgical aid was sought. Trauma had occurred in 4 out of 29 cases. Pathologically the tumour was considered to be adenoma with mucinous degeneration, and with later regeneration as cartilage. There was no evidence to support the bronchial or endotheliomatous origin of these tumours. Recurrence was shown to be due to insemination of the field of operation with fresh cells, which were found to be most active immediately beneath and frequently split the capsule. This was also considered to be the mode of growth during life. The recurrence was immediate in 5 out of 9 known time periods, and averaged one and a half years; and reoperation took place on the average after 5.5 years' delay. Three cases, previously the subjects of recurrence, had reached the five years' limit of cure. No evidence was obtained that operation hastened recurrence or shortened the life of a patient.

Carcinomata were of two types—the spheroidal and the cuboidal celled; 35 per cent. originated in simple tumours. More frequent in females, the malignant change in a simple tumour occurred about the age of 38. Pain, rapid growth, early fixation, and facial paralysis characterized these tumours. Lymphatic glands were involved late.

Sarcomata, round and spindle celled varieties, occurred; the only case traced died five years after the onset of the disease, and two years after operation. Radium had a beneficial effect on certain cases of simple origin.

The seventh ordinary meeting of the Liverpool Medical Institution was held on February 3rd, with the President, Dr. J. E. GEMMELL, in the chair. Mr. THURSTAN HOLLAND read a paper on "Some of the rarer conditions of bones." He showed radiographs of some of the accessory bones of the foot and of the sesamoid bones, and discussed their importance from the point of view of industrial injuries and compensation. Radiographs of six cases were shown in which the bone of Vesalius was present in both feet; and the question was discussed in detail of differentiating between the sesamoid of the peroneus, the presence of a true bone, and epiphyses at the base of the fifth metatarsal. Two cases of Köhler's disease of the scaphoid bone were demonstrated, and radiographs showed the condition at an initial stage and two years later. The paper concluded with a description of an exceedingly rare condition of the patella, in which radiographically there appeared to be an epiphysis on the upper and outer sides of both patellae.

Dr. BALME delivered an address on "Surgical practice in China and recent developments in medical education," and showed a large number of interesting lantern slides.

RADIUM THERAPY.

At a meeting of the Nottingham Medico-Chirurgical Society on January 5th Dr. STANLEY GREEN of Lincoln read a paper on radium therapy. After a description of the apparatus and the methods which he employed, Dr. Green said that his experience was that primary carcinoma could not be cured by radium, and that where operation was possible the surgical procedure should be carried out; if recurrence took place it could frequently be kept in check by radium, cases of carcinoma mammae being described where this took place. The treatment of carcinoma of the rectal ampulla with radium, after left inguinal colostomy, was also recommended and described, and Dr. Green put forward a plea for the treatment by radium of inoperable cases of carcinoma of the cervix uteri, pointing out that by this means possibly 20 per cent. of these cases would become operable. The favourable results of radium therapy in superficial conditions such as keloid cicatrix, lupus vulgaris, and lupus erythematosus,

was emphasized, and Dr. Green mentioned five cases of endothelioma of the nasal septum which had been successfully treated by radium. The treatment of rodent ulcer by radium was strongly recommended as a result of the numerous successful cases of varying dimensions that the speaker had had, while he had treated two cases of cavernous naevi of the face with excellent results.

A CLINICAL meeting of the West London Medico-Chirurgical Society was held at the West London Hospital on February 4th, with the President, Dr. F. J. McCANN, in the chair. A number of interesting cases were shown by Mr. ASLETT BALDWIN, Mr. B. SANGSTER-SIMMONDS, Dr. BURNFORD, Mr. TYRRELL GRAY, and others. Dr. S. D. CLIPPINGDALE exhibited a walking-stick, now in the possession of the Fagge family, said to be 200 years old, which was of the type used by medical men of the period, containing a phial and measuring glass in its hollow handle and shaft.

Rebivus.

THE CEREBRO-SPINAL FLUID.

In his monograph¹ on the cerebro-spinal fluid Professor WILLIAM BOYD of Manitoba presents a useful and concise summary of the available knowledge with regard to the physiology and pathology of this important secretion. The origin, course, and destination of the cerebro-spinal fluid are considered in the light of the important experimental work of Leonard Hill, Weed, Dandy, and others. It would seem that the choroid plexus, although the chief, is not the sole source of the fluid; that the quantity in an adult man is probably in the neighbourhood of 120 c.cm.; and that experimental observations on the absorption of dye from the subarachnoid space, and its subsequent excretion into the urine, indicate that the fluid can be replaced four or five times over in the twenty-four hours.

Factors that are known to influence the flow are next considered, and attention is drawn to the interesting observation of Dixon and Halliburton that certain substances, such as extracts of brain or choroid plexus, act as cerebral "lymphagogues," probably through the action of a special hormone. Even more important, however, is their observation that excess of carbon dioxide in the blood causes an increase in the flow of the cerebro-spinal fluid. This is the probable explanation of a fact observed during the late outbreak of cerebro-spinal fever, namely, that far more cerebro-spinal fluid may be obtained when lumbar puncture is performed under a general anaesthetic than is the case without one. Possibly, as Professor Boyd suggests, the increased flow under such conditions is brought about by the circumstance that the cerebro-spinal fluid is a means whereby carbon dioxide is rapidly excreted from the blood; hence, when under the anaesthetic the blood content of carbon dioxide rises, the flow of cerebro-spinal fluid is stimulated.

It would appear that comparatively few substances pass from the blood into the cerebro-spinal fluid. This impermeability of the choroid, however, is not quite complete. According to Professor Boyd, alcohol, chloroform, and acetone are allowed ready passage. Whether urotropin can pass through is disputed. On the contrary, substances injected into the cerebro-spinal system are rapidly absorbed into the blood, and may appear in the urine within twenty minutes. Even more striking than this rapidity of absorption from the cerebro-spinal fluid is the amount of fluid that can be absorbed by that route. Professor Boyd directs the attention of therapeutists to the fact that "anything up to a litre of normal saline may be run into the subcerebellar cisterna of a dog, and absorbed in the space of one or two hours." The greater part of this absorption appears to take place from the cranial subarachnoid space.

The changes undergone by the cerebro-spinal fluid in disease are thoroughly dealt with, and we note with approval that the author makes full reference to the work of British observers in this field. Amongst other things, attention is drawn to the valuable evidence to be obtained in cases of

¹ *Physiology and Pathology of the Cerebro-spinal Fluid*. By William Boyd, Professor of Pathology, University of Manitoba; Pathologist, Winnipeg General Hospital. New York: The Macmillan Company, 1920. (30s. net.)

suspected uraemia by measuring the urea content of a sample (5 c.cm.) of cerebro-spinal fluid, and also to the recent demonstration by Cauti of the value of this procedure for distinguishing certain cases of cardiac disorder clinically closely simulating uraemia from the true condition. It would seem to be established that measurement of the amount of urea in the cerebro-spinal fluid is not only of practical importance in the diagnosis of uraemia, but, further, that, as Mestresat first pointed out, the quantity of urea found there during an attack of uraemia is a good guide to prognosis.

We can cordially recommend this monograph, which satisfies a distinct want and provides an excellent synopsis of a subject of increasing importance. The subject matter is well set out, the book is clearly written, and its value is greatly enhanced by the fullness of the references. The only criticism that we have to make is that reference to work done in this country on the specific therapy of cerebro-spinal fever during the recent outbreak is lacking: a defect that doubtless will be remedied in future editions.

GOUT.

To write a comprehensive and intelligible account of gout is a difficult task, and, indeed, is probably harder now, on account of the greater accumulation of data without a corresponding justification for dogmatism, than at the time when the treatises of Sir Alfred Garrod (1859) and Sir Dyce Duckworth (1890) appeared; with them comparison must inevitably arise. In his pleasantly written volume on *Gout* Dr. LLEWELLYN JONES LLEWELLYN² has succeeded in providing the reader with a fair and well-proportioned account of the very varied views of other workers, past and present, and at the same time has made his convictions, derived from much experience at Bath, quite clear. The theoretical and the practical considerations are skilfully balanced, but the practising physician rather than the laboratory worker appears to be the directing spirit, as, indeed, should be the case.

After a review of the chemistry of gout, the weight of clinical evidence is shown to be against the primary renal origin of gout; and in the section on uricaemia full advantage is taken of the results from Folin and Denis's colorimetric method of detecting uric acid in the blood, and of Mc Lester's figures showing the uricaemia of normal persons and in various diseases. Contrary to what might be expected, there is not any constant relation between uricaemia and uratisis or the presence of tophi: Dr. Llewellyn believes that formation of tophi is preceded by a local inflammatory reaction of varying severity, and that, as uric acid and its precursors are non-toxic, the tophi are the result and not the cause of the inflammation. He is a strong advocate of the infective theory of gout, and insists that inflammatory reaction invariably precedes all gouty processes, articular and ab-articular, the inflammation being due to infection or subinfection which may be of various kinds and is therefore not specific. Local foci of infection, such as oral sepsis and tonsillitis, are extremely common in the gouty, and thus cause the arthritis; further, the probable diminution of rheumatic fever since tonsillectomy has come into vogue is compared with the increasing rarity of gout which synchronizes with the more general treatment of oral sepsis. The gastro-intestinal disorders which chequer the course of gout increase the pathological activities of the intestinal flora and incidentally the liability to infection at various sites of the alimentary canal. The author holds that it is not the quality but the quantity of food that is responsible for gout, by producing a toxic condition of the blood plasma and so lowering the resistance of the individual to microbial invasion; alcohol and lead, which do not produce gout in the absence of an hereditary proclivity, similarly act by impairing the protective mechanisms of the body and so favouring infection, especially from the gastro-intestinal tract. Mr. W. M. Beaumont contributes a chapter on ocular disease in the gouty, and, after full discussion of the late Sir Jonathan Hutchinson's views on iritis, concludes that it is unwarrantable to speak of gouty ocular disease, for there is nothing in the character of the inflammation specific of gout.

² *Gout*. By Llewellyn Jones Llewellyn, M.B.Lond.; with a Section on Ocular Disease in the Gouty by W. M. Beaumont. London: William Heinemann (Medical Books), Ltd. 1920. (Roy. 8vo, pp. 487, 1 plate 30s. net.)

In his full clinical account of the disease Dr. Llewellyn points out that gout disposes to fibrositis by favouring infection, that acute gout is not infrequently complicated by fibrositis, and that the same infection sets up these two changes. A very definite view is expressed about irregular and retrocedent gout; there is no anatomical evidence of gouty inflammation in the viscera, and the gastro-intestinal disorders, such as dyspepsia and acidity, attributed to gout, are in reality etiological factors and not symptomatic manifestations of that disease; the cases of so-called "retrocedent" gout to the heart or the brain are usually due to myocardial degeneration, arterio-sclerosis, or renal disease.

The section on the important subject of treatment bears witness both to the author's practical experience and to his sense of proportion. Commencing with the radical treatment of local foci of infection or toxic absorption, stress is laid on the importance of being on the look-out for more than one such focus; thus oral infection may be associated with tonsillar, aurial, cholecystitic, or appendix infection. With regard to diet, it should be remembered that each gouty subject is a law unto himself and that it is the individual and not the uric acid that must be treated. The dietary should not be stereotyped, but should be directed to obviate dyspepsia and promote a sepsis of the alimentary tract. With regard to the relative claims of colchicum and atophan, the author points out that the vegetable drug influences the real cause of the arthritis, whereas the synthetic product promotes absorption and elimination of the resulting uratic deposits, and should therefore be given after a paroxysm in order to prevent tophiaceous formations.

DISEASES OF THE LUNGS AND PLEURAE.

The nine years that have elapsed since the date of the last edition have necessitated many changes in the sixth edition of the well known work *On Diseases of the Lungs and Pleurae*³ by Sir R. DOUGLAS POWELL and Sir P. HORTON SMITH HARTLEY. New chapters have been added on chylothorax, massive collapse of the lung, sporotrichosis, and artificial pneumothorax; the section on haemothorax has been supplemented by an account of haemothorax following wounds of the chest, thus summarizing the British experience gained during the war. Reference is duly made to the four types of pneumococci established at the Rockefeller Institute, and to the value of the anti-pneumococcal Type I serum in cases proved to be due to this type. It would be interesting to know if this form of differential treatment has been attempted in this country, and if the authors have had any personal experience of it; they have, however, employed pneumococcal vaccines in many cases of pneumonia without any well-marked beneficial effect, and sensitized (preferably autogenous) vaccines with perhaps more encouraging results. The rather condensed account of bronchopneumonia contains a reference to mustard-gas poisoning. The description of influenza pneumonia might perhaps have contained some reference to W. G. MacCallum's splendid monograph on the pathology of the pneumonia in the United States Army Corps during the winter of 1917-18. The anapylactic origin of asthma and the recent work of Drs. John Freeman and Chandler Walker find a place, and a wise caveat is entered as to the use of therapeutic serums in asthmatic subjects.

The description of pulmonary tuberculosis occupies two-fifths of the volume, and reflects the mature and wide experience of the authors; many additions, such as Professor Karl Pearson's and Dr. John Brownlee's work on epidemiology, have been made, and new observations and views are submitted to careful criticism. Hilum tuberculosis is regarded as an unnecessary addition to nomenclature, as in the adult there is reason to doubt the correctness of the statement that tuberculosis spreads continuously outwards from foci at the hilum: tuberculosis of the glands in the hilum is of course well recognized, but this is not the form of disease to which the term is usually applied. The remarks on tuberculin have been considerably curtailed in accordance with the opinion that, except in special cases, less value than formerly can

³ *On Diseases of the Lungs and Pleurae*. By Sir R. Douglas Powell, Bt., K.C.V.O., M.D., etc., and P. Horton Smith Hartley, C.O. M.D., F.R.C.P., Sixth Edition. London: H. K. Lewis and Co., Ltd. 1921. (Demy 8vo, pp. 818; 65 figures, 36 plates. 42s. net.)

be attached to its use; and, in speaking of the dosage, the cubic millimetre, as suggested by Drs. Morland and Riviere, is employed, instead of the cubic centimetre. In conclusion, this familiar work, which is only some fifty pages longer than the last edition, can confidently be recommended as a safe guide to the practitioner in search of authoritative medical opinion in this country at the present time.

MACEDONIA.

PROBABLY it is true to say that, as the authors of *Macedonia: A Plea for the Primitive*⁴ would imply, less is generally known of Macedonia, its peoples and their customs, than those of any other part of Europe. This is true in spite of the fact that a British force was in occupation of the southern parts for three years, and that over 400,000 men passed through that force. For the majority, however, the opportunities of observation were very limited; the authors of this book were more fortunate, and appear to have visited nearly all parts of the country, among others Mount Athos and some of its monasteries, which can have changed but little since Curzon wrote his great book. The volume is not arranged after the manner of a guide-book, but according to subjects; thus there are chapters on native dress, on villages and houses, on the products, among which tobacco and dried fruit (currants) are probably the most important; on the Greek Church and the Turkish mosque, and on marriage customs. Agriculture is in a primitive stage. Threshing is carried on by a method which we have not hitherto seen described: corn is laid out on the threshing floor "to a depth of an inch or more, and large pieces of wood, like flat toboggans, set underneath with sharp projecting flints, are dragged over it by donkeys, ponies, or oxen." The flints, it is stated, are chipped after the prehistoric manner; this is very possible, for the last of the East Anglian flint-chippers died only a few years ago. Three chapters are given to Salonica, the last describing the great fire which destroyed the larger part of the city in August, 1917. The pleasure of reading the book is greatly increased by Dr. H. A. FAWCETT's drawings, four in colour, and many in black and white. The text, we gather, is by Mr. A. GOFF, whose style is rather unusual. "Simplicity is Nature's first step and the last of Art" is taken as a motto, and there are many references to it, but the author does not seem to have taken it to heart. Again, such a phrase as "a full conception of the degree of prolixity which it [insect life] attains" seems to need reconsideration.

NASAL ANATOMY.

DR. SCHAEFFER, in his monograph on *The Nose, Paranasal Sinuses, Nasolacrimal Passage-ways and Olfactory Organ in Man*,⁵ has presented an elaborate survey of the anatomy of these parts in the widest sense of the word. The author has been impressed with the unfortunate results of teaching students of anatomy one rigid description as the typical form of each region, organ, and structure in the body. Some general instruction of this nature is clearly necessary to form an elementary understanding of anatomical structure, but the author very wisely emphasizes the fact that a series of dissections soon shows that there is no fixed and unalterable type in many parts of the human body. Students, however, are very apt to acquire the idea that any deviation from an arbitrary standard constitutes an anomaly, whereas it would be almost impossible to find a body that answers in every detail to the typical form, which is a kind of average taken from a large number of specimens. In the nose wide departures from the composite anatomical standard are particularly frequent. The present volume is of value, both in establishing this general idea and also in describing the large number of structural variations which occur, and in tracing the developmental origin of their production. An excellent example of this is furnished by the variations in the nasolacrimal ostium, which the student usually conceives as an

opening guarded by the valve of Hasner. The clinical value of such anatomical knowledge, especially when based on a sound general conception, cannot be over-estimated. The chapters which concern the accessory sinuses, and especially the section dealing with the frontal sinus, are very good and of great practical value.

The work is founded on the author's observations and researches; he is sparing in his references to other publications, and has not attempted a general survey of the literature of the subject; nevertheless the book is sufficiently comprehensive. Some rather doubtful matter on the physiological relations of the nose to other parts has been introduced, presumably for the sake of completeness. The book, however, is one which well repays close study, and for anyone interested in the numerous anatomical problems connected with the nose and its accessory sinuses the illustrations are in themselves an education.

THE TRIAL OF THE WAINWRIGHTS.

THE "Notable English Trials" series appeals in a double sense to medical men, first to their professional interest in medico-legal problems and then in respect of human nature and its manifold twists and unexpected features. A good detective story usually has a peculiar attraction to a mind trained to track out the origin and course of morbid function, and this series shows how greatly fact may exceed fiction in its surprises and fascination. The twenty-fourth volume of this series, *The Trial of the Wainwrights*, edited by the late H. B. IRVING,⁶ who also brought out the volumes on Franz Müller and Mrs. Maybrick, is an admirable case in point. In the introduction the editor has graphically sketched the murder of his paramour Harriet Lane by Henry Wainwright, the brushmaker of the Whitechapel Road, in 1874, his successful concealment of her remains for a year, their dramatic discovery when he moved them to what would have been a safer hiding place, his trial in company with his brother Thomas, and his execution. As some will remember, the body was originally buried with chloride of lime, which preserves rather than destroys human remains, and so led to the murderer's undoing when, a year later, the boy to whom Wainwright entrusted the grim parcel, found to his horror a human hand, and straightway communicated with the police.

Wainwright was not the first nor the last man to commit murder in order to preserve a respectable reputation, and an interesting comparison is drawn between him and John Tawell the quaker, John Beale, and Cadwallader Jones, like him married men who murdered their mistresses, and his namesake "kind light-hearted" Thomas Griffith Wainwright, the friend of Charles Lamb. The full evidence of the later trial is illustrated by photographs of Henry Wainwright and some of the eminent counsel concerned. The very natural interest felt in the talented editor has been happily satisfied by an admirable appreciation from his friend Sir Edward Marshall Hall, who gives much interesting information about his criminological methods, and says: "If it had not been his fortune to be the son of a great actor and a great actor himself he might have earned fame as a great advocate, but his was the better rôle."

NOTES ON BOOKS.

SIR D'ARCY POWER has published his second Vicary Lecture on *The Education of a Surgeon under Thomas Vicary*,⁷ with many interesting illustrations. The lecture shows how much the education of a surgeon owes to the wisdom of a few great men in the critical times with which it deals, when the fraternity of surgery could no longer continue along the traditional lines and there was a real danger of surgery passing into the hands of a trade guild. An abstract of the lecture was given in our issue of November 13th, 1920.

We are indebted to the Registrar of the General Medical Council for a copy of the new edition of the *Report as to the Conditions under which Medical and Dental Practitioners Registered or Legally Qualified in Their Own Country may*

⁴ *Macedonia: A Plea for the Primitive*. By A. Goff and Hugh A. Fawcett, M.R.C.S. With illustrations by Hugh A. Fawcett. London: John Lane, the Bodley Head; New York: John Lane Company. (Med. 8vo, pp. xvi + 274; illustrated. 41s. net.)

⁵ *The Nose, Paranasal Sinuses, Nasolacrimal Passage-ways, and Olfactory Organ in Man. A Genetic, Developmental, and Anatomical-Physiological Consideration*. By J. Parsons Schaeffer, A.M., M.D., Ph.D., Professor of Anatomy at Jefferson Medical College, Philadelphia. Philadelphia: P. Blakiston's Son and Co. 1920. (Demy 4to, pp. 387; 205 figures. 10.00 dols.)

⁶ *Trial of the Wainwrights*. Edited by H. B. Irving, M.A. Oxon., with an appreciation of the editor by Sir Edward Marshall Hall, K.C., Edinburgh and London: William Hodge and Co., Limited, 1920. (Demy 8vo, pp. 235. 8 illustrations. 10s. 6d.)

⁷ *The Education of a Surgeon under Thomas Vicary*. By Sir D'Arcy Power, F.R.C.S. Bristol: Wright and Sons, Ltd. (Crown 4to.)

*Practise Abroad.*⁸ The first edition was issued in January, 1910, and a revised and expanded edition in August of the same year. The report is founded either on answers received from the authorities of the several countries or on information in the possession of the General Medical Council. The new, fifth, edition has been brought up to date, and British practitioners who are thinking of going abroad will find in this volume the most comprehensive and accurate information available as to the conditions of practice in other countries. Requirements, however, are liable to change, and the registrar, Colonel Norman C. King, has been careful in all cases to supply the name of the official from whom the necessary forms and latest details can be obtained. This very necessary precaution should always be taken.

Under the auspices of the Carnegie Endowment for International Peace a valuable series of economic studies of the war is being published, under the general editorship of Dr. David Kinley, professor of political economy in the University of Illinois. It includes such subjects as the early economic effects of the war on Canada, Chile, and Peru, the financial history of Great Britain in 1914-18, British war administration, negro migration during the war, the Germans in South America, Government war contracts. The volume now received is on prices and price control in Great Britain and the United States during the world war,⁹ and is by Dr. SIMON LITMAN, professor of economics in the University of Illinois. His study of the question shows that legal action on the whole has had little effect in preventing or removing the evil practices that have called forth so much popular denunciation; and the author has included detailed discussions, of much interest, on such matters as causes of the rise in prices, profiteering, and industrial unrest. Although each generation, like each individual, must learn in large measure from its own experience, nevertheless there are in every age some minds able to exert an influence in a new crisis in the direction of sanity and safety by their studies of similar experiences in the past; and to that extent this and other volumes of the series will, it is hoped, have a permanent value.

In *Lays by the Way* Dr. R. B. GREAVES¹⁰ of Sheffield has joined the ranks of medical men who have found expression for their experiences in verse. In the twenty-one short poems there are many touches that will appeal to his silent brethren, particularly that entitled "The Doctor."

⁸ Constable and Co., Limited. Price, 2s. 6d.; post free (U.K.) 2s. 9d.; Colonies, 3s.; abroad, 3s. 3d.

⁹ *Prices and Price Control in Great Britain and the United States during the World War.* By Simon Litman. New York: Oxford University Press, American Branch, 1920.

¹⁰ *Lays by the Way.* By R. B. Greaves. London: Erskine MacDonald, Ltd. 1921. (Cr. 8vo, pp. 72. 3s. 6d. net.)

APPLIANCES AND PREPARATIONS.

Modified Duval's Lung Forceps.

MR. BRYDEN GLENDING, M.S., F.R.C.S. (Aspley Guise, Beds), writes: When using Duval's special lung forceps in chest cases during the war I was agreeably impressed with their extremely sensitive and at the same time assured, non-slipping grip, and came to employ them largely in abdominal surgery, where their tenacious but delicate hold proved invaluable, notably for holding or

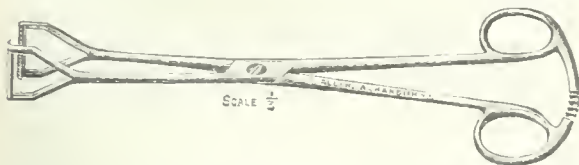

retracting the uterus, appendages, cysts, small tumours, and even gut, when applied over gauze. The original model has a triangular head, of which the angles are too prominent and the bite wider than necessary. Messrs. Allen and Hanburys have therefore modified it for me by removing the sharp angles of the jaws, increasing the length of the instrument, making it more suitable for deep abdominal work, and fitting the bowed end lock, which prevents sutures getting caught up between the finger rings as in the ordinary pattern of forceps.

A Tray for Tuberculin Administration.

Mr. F. E. GUNTER (London, W.C.) writes: Finding the need of a simple rest or tray for the impedimenta which one uses in giving tuberculin injections, I have designed

the tray shown in the accompanying illustration. Such an appliance should be simple, stable, and easily rendered aseptic: the tray will be found to meet these requirements. Dr. H. A. Ellis has suggested to me that it would

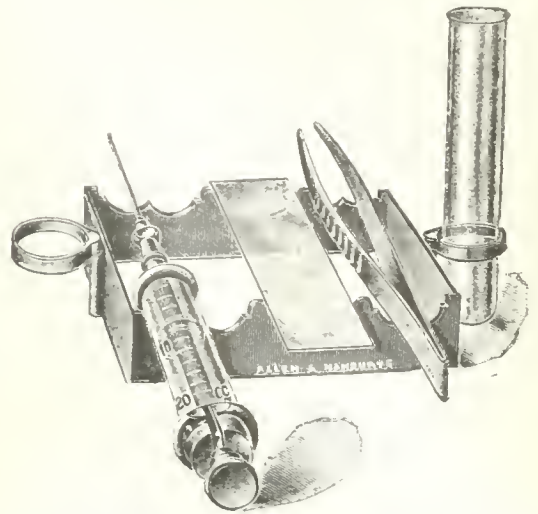

be of more value to laboratory workers if the spaces were adapted to hold slides and if a holder for test tubes were added, and these alterations have been made. The tray has been made to my design by Messrs. Allen and Hanburys, Ltd., 48, Wigmore Street, London, W.1.

ROYAL MEDICAL BENEVOLENT FUND.

At the meeting of the Committee held on February 8th seventeen cases were considered, and £245 voted to fifteen applicants. The following is a summary of some of the cases relieved:

M.R.C.S. Eng., aged 50, married. Suffers from facial paralysis following paralysis. Dependent on daughter, who supplements her income by taking paying guests. Applicant receives the old age pension. Voted £13.

M.B., C.M. Edin., aged 67, married. Asks for help to meet expenses. Stepdaughter, age 145, dependent owing to deafness since birth. Wife takes boarders to supplement income. Has had to sell furniture to make ends meet, and within the last twelve months has paid off £100 for debts. Rent and rates £69 per annum, amount owing £36. Voted £26 in twelve instalments.

Daughter, aged 70, of M.R.C.S. who died in 1878. Applicant used to receive £100 per annum from friends, but this sum is no longer available, and her niece who looked after her has now to help her own aged mother. Old age pension is being applied for. Voted £10 in four instalments.

Widow, aged 44, of M.B., C.M. Glasg., who died in 1903. Applicant left with three children. She acts as a companion help at £60 per annum. Her eldest son is self-supporting, but she has to pay part of board for second boy, aged 17, who is an engineer's apprentice. Asks for help to meet expenses. Voted £20 in four instalments.

Daughter, aged 47, of M.R.C.S. Eng., who died in 1888. Owing to ill health she is entirely dependent on her mother, who receives a pension from the fund. Relieved once, but asks for help in twelve instalments. Voted £12 in twelve instalments.

Widow, aged 54, of L.S.A. Lond., who died in 1911. Applicant has a cottage in Cornwall, and earns money by taking boarders and running a tea garden, but owing to bad weather she is unable to meet expenses. Applicant has to find £2 per week for her two sons. Rent and rates £12 per annum, and arrears £18 per annum. Relieved four times, £35, last time January, 1919, £10. Voted £13.

Subscriptions may be sent to the Honorary Treasurer, Sir Charters J. Symonds, K.B.E., C.B., F.R.C.S., at 11 Chandos Street, Cavendish Square, London, W.1.

The Royal Medical Benevolent Fund Guild is overwhelmed, in these days of exorbitant prices for clothing and household necessities, with applications for coats and skirts for ladies and girls holding secretarial posts, and suits for working boys. The Guild appeals for second-hand clothes and household articles for the benefit of the widows and children who in happier times would not have needed assistance. The gifts should be sent to the Secretary of the Guild, 43, Bolsover Street, W.1.

MESSRS. OLIVER AND BOYD announce for early publication a third edition (rewritten and greatly enlarged) of *The Clinician's Study and Treatment of Sick Children*, by Dr. John Thomson.

At the request of the League of Red Cross Societies a large typhus research hospital will be established in connexion with the new American Red Cross Hospital recently opened at Wilmo.

ASTLEY COOPER AND HUNTERIAN PRINCIPLES.

SIR CHARTERS SYMONDS'S HUNTERIAN ORATION.

THE Hunterian Oration was delivered before the Royal College of Surgeons of England on February 14th, the anniversary of Hunter's birth, by Sir Charters J. Symonds, K.B.E., C.B., consulting surgeon to Guy's Hospital, who took as his main subject, "Astley Cooper and Hunterian principles." After a preliminary tribute to the memory of Hunter, the great biologist and surgeon, the orator named some of Hunter's pupils who left their mark on surgery and became teachers in the schools. He then set out to trace in the career of one distinguished pupil—Astley Cooper—the influence of Hunter's teaching, and to show how the principles laid down were expanded and applied by one who was, perhaps, the best exponent of the application of Hunter's teaching and one who did more than any other surgeon of his time to stimulate inquiry.

Early Career.

Astley Cooper had just completed his 16th year when he arrived in London in August, 1784, to become apprenticed to his uncle, Mr. Cooper, at that time surgeon to Guy's Hospital. He soon became a favourite in the household of Mr. Cline, where he lived, and shortly afterwards, at his own request, he was transferred as apprentice to Cline, a circumstance that had a far-reaching effect on his future. Cline, aged then about 38, was a surgeon at St. Thomas's Hospital; he was a follower of Hunter, carried out his principles and his teaching, followed his experimental methods, was a good practical surgeon, and a man of sound judgement. At Cline's suggestion, no doubt, Astley Cooper began attendance at Hunter's lectures, and had the priceless advantage of talking over the subject with his master and with other apprentices, one of whom interested him in botany and another in physiology. In his indentures it was provided that he might spend a session in Edinburgh, and thither he went in October, 1787. He carried introductions to the leading professors, whom he was anxious to see and hear. He was by this time a good anatomist, and moreover had spent much time at the bedside and had made careful notes of the cases, so that he was in a position to discuss both anatomical and surgical questions. From his frank and courteous manner, free from assertion, he was well received, and was made a member of the famous Royal Medical Society, and offered the presidency should he return. He made good use of these seven months, spending his time in the infirmary, making notes of the cases, and attending lectures by Monro and others. At Edinburgh he learned order and system, for which the teaching has always been famous, and under this guidance he planned a method of examining cases of disease which led to the surest and safest mode of forming a diagnosis, and this he pursued throughout his life, to the advantage of his teaching and his practice.

In 1789 Astley Cooper was appointed demonstrator of anatomy at St. Thomas's, and two years later (at the age of 23) he was asked by Cline to take a share in the lectures on anatomy and surgery. Hitherto the subjects of anatomy and surgery were combined in the same lectures, a plan which Astley Cooper considered injurious to both. After some hesitation Cline agreed to their separation. Cooper now resolved to devote the next three years solely to improving his knowledge of anatomy and surgery, without endeavouring to amplify his income from the lectureship by seeking private practice. Disappointed to find that the class at his first course of lectures was inattentive and decreasing in numbers, he concluded it was necessary for his pupils to have a considerable knowledge of surgery before they could comprehend the principles enunciated by Hunter. He at once changed his method, and with immediate success. Cases of disease and injury were brought before the class, the cause and nature of the disease or accident described, with the appropriate treatment, and afterwards the physiological and pathological bearings applied and further illustrated by morbid specimens and

experimental results. This method he pursued throughout his forty years, enriching his lectures with cases from his own experience, and as this widened the lectures became more and more valuable. But never did he lose sight of the scientific side or relapse into the method of earlier lecturers, who dealt with cases only. Always inquiring by dissection, by study of disease in the living and the dead, and by experiment, he was constantly improving his teaching. The lessons to be learnt from such vast inquiry were brought to the service of his class, and each year further light was thrown upon old subjects, and not from second-hand knowledge, but from the actual observation of the teacher himself.

So successful had his lectures become in his second course that when he began the third in 1793 the number of entries had doubled. In this year, at the age of 25, he was appointed lecturer at Surgeons' Hall. To improve further the education he very soon after his appointment promoted a society, confined to the pupils of Guy's and St. Thomas's Hospitals, where cases of interest were shown and discussed. This existed for several years, and was of particular value to the younger men, for the discussions at the Physical Society were beyond the range of any but the senior members of the schools. In a word, he devoted the first three years to the welfare of the students, and when one adds his personality, the buoyant spirits, the sense of humour, the hearty laughter, his readiness to help in their work, and his kindly advice and often assistance in more substantial ways, is it any wonder that he was sought after as a teacher and beloved as a friend? For nine years he continued these demonstrations and lectures, pursuing without intermission his studies in anatomy, comparative anatomy, and physiology. He had gradually obtained private practice, and by the end of the period his income from this source was said to amount to £1,000. In 1800 he was appointed surgeon to Guy's Hospital, thus securing the acme of his ambition at the age of 32. He was well equipped for the position, for though he could not have performed many operations, he had acquired from his dissections such a knowledge of anatomy as would enable him to work with accuracy and speed, and from his experiments on animals a refinement of technique not possessed by any of the other competitors.

Inquiry by experiment and the acquisition of dexterity by operating on animals is (Sir Charters Symonds continued) unfortunately restricted in our country to an extent that has for long checked advance in surgery. Operation on the dead cannot compare with that on the living, even if only on one of the lower animals. In the days of Astley Cooper, when anaesthesia was unknown, time was of the essence of success and of mercy. It was said by one of his colleagues that Astley Cooper could operate as well with an oyster knife as another surgeon with the best out of Landry's shop. This raises the important question of operations on living animals as part of the training of a surgeon. In certain branches of surgery this would be most valuable, and in one at least—operations on the brain—it seems essential. Harvey Cushing, than whom no better authority could be quoted, urges this practice in a recent essay. To learn how to arrest haemorrhage, to handle the brain without injury, to trephine a thin bone without harm to the meninges, to expose any given part by the most direct route, are steps in technique which should be acquired before operating on the human subject. Take, again, operations on the eye, intestinal suturing, or, more important still, suture of the common bile duct and of the ureter, and the suture of arteries—will anyone deny that to approach such operations after adequate practice on living animals cannot but lead to better technique and greater success? Is it not in the interest of the public that facilities should be given to those preparing for important surgical positions to acquire such experience, especially when anaesthesia removes all reasonable objection?

Astley Cooper as Teacher and Surgeon.

Astley Cooper was undoubtedly a great teacher, and in this regard probably had a wider influence than anyone of his time. He no doubt possessed a natural gift for teaching, but this would not have gained him the position he obtained in this respect had it not been for his industry and his determination to enunciate no doctrine unless proved by observation and experiment. He was not a

genius in any sense, and he himself attributed his success entirely to his industry. He had clear ideas as to how knowledge should be acquired, and constantly impressed upon his class the importance of personal observation. He recognized the evil effect of too much teaching, and inculcated personal observation of the processes of Nature.

As a surgeon Astley Cooper's name will always be associated with the ligature of arteries, for he it was who first put a ligature on the carotid; he was one of the earliest to tie the external iliac, and the only surgeon of his time to ligature the aorta. From his earliest days as an apprentice, and all through his life, he carried on experiments of all kinds, and to him was largely due the demonstration of anastomotic circulation. Hunter had ligatured the femoral for the cure of popliteal aneurysm in 1785, when Astley Cooper was in the first year of his apprenticeship to Cline. No doubt master and pupil talked over the revolution in surgery which had saved so many lives, and saw the application of the principle to other situations. During the years that followed he tied all the main vessels in dogs and other animals to prove the truth of the anastomotic circulation. Both carotids were held to be essential to the integrity of the brain in man and animals. The fallacy was soon dismissed as far as dogs were concerned, for he tied both vessels simply and simultaneously without ill effects, and later combined ligature of both carotids with double ligature of the vertebrales. This was generally fatal, but one dog at any rate survived. The performance of such a feat in half an hour was a tribute to the operator's accurate anatomy and technical skill. It was his custom also to ligature the carotid at his lectures to demonstrate the safety as regards the brain. It was, however, generally considered that such an operation in man was "impracticable" or would be injurious to the functions of the sensorium." Cooper, however, had found a case where one carotid had been obstructed by disease, and Dr. Baillie had communicated an example of complete obstruction of one and partial of the other carotid without ill effects. The defence of the operation put forward by Travers after his own operation shows the controversy that existed, and emphasizes the boldness of Cooper's undertaking.

The opportunity long anticipated at last arrived, and it was on November 1st, 1805, that he ligatured the common carotid in a woman. It was an advanced case of aneurysm, and occupied so large a space that it was just a question whether there was room for a ligature between the sac and the clavicle. In the skilled hands of Astley Cooper, however, that was accomplished which few would have attempted. The patient died from suppuration of the sac twenty days later. Astley Cooper was not discouraged, for he had established two points: that the carotid could be safely tied and without injury to the brain. In reading the account before the Medico-Chirurgical Society on January 29th, 1806, he says: "The failure was due to the operation being too long delayed, and it will not prevent my performing it in any case in which the disease is somewhat less advanced." It is not difficult to imagine the criticisms that would be levelled by those who thought such an operation unjustifiable.

The second opportunity came on June 22nd, 1808, and was a complete success. In reading this case before the same society reference was made to experimental ligature "many years ago." On the death of this patient, thirteen years later from apoplexy, the brain was obtained, and a drawing is given in *Guy's Hospital Reports*, vol. i. Both these operations were carried out in the presence of several surgeons of the hospitals and some visitors, and one cannot but admire the courage of the operator's convictions. In both instances examination showed that no injury had been sustained by neighbouring structures. On the same day on which the second operation took place he ligatured the external iliac in an urgent case in which rupture was imminent. Eighteen years later the specimen was obtained at considerable expense and trouble, for the man lived in the country.

Finally came the culmination of this work in the ligature of the aorta. The operation was performed on June 25th, 1817, by the transperitoneal route. In referring to his experiments, when reading the paper on ligature of the carotid, he says: "Lastly, I was anxious to ascertain when even the aorta was tied if the blood would still find

its course by anastomosis." This he had demonstrated in dogs, and had repeated the experiments two years before—that is, in 1815. "The animal," he says, "survived the experiment and maintained his usual health." Again it was unfortunate that the case was an advanced one, and the man greatly reduced by haemorrhage. The aneurysm was of immense size and filled the left iliac fossa; operation by the route adopted on animals was impossible, and he determined, rather than that the man should be left, to open the abdomen, displace the intestines, and secure the artery above the bifurcation. With his usual solicitude he explained the position to the patient, who replied, "Sir, I leave myself in your hands." With that dexterity which was the outcome of his experimental inquiries, he then placed the ligature, without, as it proved, any injury to other structures. Though the man lived only forty hours the right limb had recovered its warmth and sensation, but the left—the affected side—remained cold and discoloured. This he considered was due to the pressure of the large aneurysm interfering with the anastomosing vessels.

Thus he had broken new ground, had thought out the details of possible operations, had by experiment on animals proved that so far as they were concerned success was obtained, and therefore might be anticipated in man. "The secret of success in life is for a man to be ready when his opportunity comes."

Hunter and Cooper.

The portrait by Sir T. Lawrence (concluded the Orator) exhibits Astley Cooper somewhere approaching 60, and is considered the *chef d'œuvre* of this great painter. It is interesting to compare it with that of Hunter; both are looking up and into the future, both see much to be done—Hunter the philosophic genius, and Cooper his great pupil, ready for any emergency. Both Hunter and Astley Cooper fully gave of their knowledge to others, and were not concerned who discovered the truth so long as it was found. Truth to them was bigger than person or school.

Cooper died in 1841 at the age of 74, having extended and upheld the reputation of British surgery for half a century, and was buried beneath the chapel of the hospital he loved so well and whose fame he did so much to extend. By his will he founded a triennial prize, and it is significant that he directed that the first subjects for inquiry should be upon the thyroid, the spleen, the thymus, the suprarenal capsules, and the state of the blood and blood vessels in inflammation—all subjects on which he had himself made observations and conducted experiments. He foresaw that future workers, better equipped, would unravel the secrets which had baffled him. The Hunterian era awoke in the minds of men a desire to explore the old ground by new methods and to unearth the truths so long concealed. There was a spirit of adventure like that which animated the Elizabethan explorers, the ambition of the healthy human intellect to extend its range of vision and knowledge. To Hunter belongs the credit of the discovery of this new world. He it was who lighted the torch, and I hope I have shown that Astley Cooper was amongst those who first carried it forward in the race, kept it alight, and then passed it on not only undiminished, but burning with a brighter flame; and so when his course was run the goal was nearer for the part he had taken. "After brief life men die, and like runners in a race hand on their torch to another."

At the meeting of the London County Council on February 15th, Captain Swinton moved that it be an instruction to the Education Committee forthwith to confer with the Improvements and Building Acts Committees on the question of a site at Holland Park for the University of London, and to report fully to the Council thereon. By the standing orders of the Council no speeches are allowed on motions involving references to committees, and this motion, was accordingly passed without any discussion; the discussion will be forthcoming when the Education Committee reports. Captain Swinton, with the consent of the Council, withdrew a part of his motion which included reference to the availability at Holland Park of a site of ample size and convenient situation, and purchasable at a capital cost considerably less than that of the far smaller site at Bloomsbury.

British Medical Journal.

SATURDAY, FEBRUARY 19TH, 1921.

INTESTINAL PROTOZOA ENDEMIC IN BRITAIN.

PROGRESS in our understanding of the part played by pathogenic micro-organisms and their significance involves observations in at least two different directions. In the first place evidence is required of a causal relationship between a given micro-organism and the particular disease in constant and intimate association with which it is found to occur. Such causal relationship having been established, the next step is to determine the distribution of this pathogenic micro-organism in the absence of the disease; and it is to systematic work in this direction that we owe important advances in our knowledge of the genesis of epidemics, and also the comparatively modern appreciation of the part played by the healthy carrier in the conservation and transmission of infection.

Before the war the study of intestinal protozoa in the inhabitants of Great Britain was neglected. As Mr. Clifford Dobell, F.R.S., points out in a recent report¹ to the Medical Research Council, while a knowledge of protozoology was recognized as a requirement of physicians devoting themselves to tropical medicine, there were few medical men at that time who were able—or if able who saw the necessity—to study the intestinal protozoa of the resident population of Britain. This defect Mr. Dobell sets himself to remedy in the present report, wherein he describes and analyses with much care and skill, observations on the subject in question carried out by himself and his pupils and colleagues. Of the 3,000 examinations with which he deals, over 2,000 were made at Liverpool, the remaining 1,000 being carried out at Birmingham, Brighton, Leeds, Sheffield, and Reading. None of the 3,000 persons whose faeces were examined had ever been out of Great Britain, and they included children as well as adults, hospital patients, asylum patients, occupants of sanatoriums, and also recruits.

The particular protozoa of which a census was taken in this way were eight in number—namely, *Entamoeba histolytica*, the parasitic cause of amoebic dysentery, *E. coli* and three other non-pathogenic amoebae, *Lambliia* and two other flagellates. Although they differed in frequency, all of these protozoa were detected in the intestinal contents of “indigenous” inhabitants of Great Britain. It would appear that the commonest is the harmless *E. coli*, which, in Mr. Dobell's opinion, is probably present in the intestinal contents of 50 per cent. of the inhabitants of this country. Next in frequency is *Lambliia*, the carrier rate of which he puts at from 18 to 27 per cent., this protozoon being especially frequent in the faeces of children. Chief interest, however, centres round the observations with regard to *E. histolytica*. This particular protozoon was actually identified in 3.4 per cent. of the persons examined, but, for reasons stated by him, Mr. Dobell considers that the true rate is between 7 and 10 per cent.

The first question that this highly interesting observation raises is whether the amoebae identified

with *E. histolytica* are all indistinguishable pathogenically from that micro-organism, or whether at any rate a proportion of them while closely resembling *E. histolytica* in the characters at present regarded by protozoologists as differential, are possibly without the same pathogenic significance to man. It must be remembered that our knowledge of protozoa as pathogenic agents is still at an early stage, and that the more refined and specific methods of identification such as the serological tests now found necessary for identifying some of the best studied pathogenic bacteria are not at present available in the case of micro-organisms such as *E. histolytica*.

Now amoebic dysentery is a disease the pathological anatomy of which is distinctive by reason both of the ragged and deep ulcers in the wall of the large intestine, and also from the tendency of the patient to develop hepatic abscess. We know of no evidence of the occurrence of such a disease in this country on any large scale. At the same time there are records in the literature of a few individual cases of persons who have not been abroad and have suffered from a disease not unlike amoebic dysentery. Several instances of this are collected and described by Mr. Dobell in his report, and particulars are also given of two cases of amoebic dysentery, both of which appear to have contracted the disease in this country during the war. But if cases presenting the characteristic lesions of amoebic dysentery are rare in this country, cases of colitis are comparatively common, and the considered opinion of such a distinguished protozoologist as Mr. Dobell with regard to the prevalence of *E. histolytica* in the general population indicates the desirability of examining all cases of this condition for protozoa and for *E. histolytica* in particular. It is interesting to learn that already in a case of ulcerative colitis in a patient who had not been abroad Dr. P. P. Laidlaw of Guy's Hospital has succeeded in finding *E. histolytica*. It may be also that cases of diarrhoea occurring in this country are associated with protozoal infection to a larger extent than has hitherto been suspected. Mr. Dobell's report should do much to stimulate pathologists to search for protozoa in such cases, and to become more expert at recognizing these parasites than has hitherto been thought necessary.

POETRY AND MEDICAL MEN.

ABOUT five years ago Dr. C. L. Dana of New York published under the title of *Poetry and the Doctors*¹ a charming book containing a catalogue of poetical works written by medical men, with biographical notes and an essay on the poetry of certain ancient practitioners of medicine, illustrated with translations from the Latin and by beautiful reproductions of the title pages of the rarer works. Some of the 162 medical men in this catalogue, and it would not be difficult to expand the list, have been famous as poets, and doctors in little more than name—for example, Keats, Schiller, Oliver Goldsmith, and Crabbe; others, such as Akenside, Oliver Wendell Holmes, and S. Weir Mitchell, have been distinguished in both these capacities; but in most instances the lyrical efforts of the disciples of Aesculapius have been of the nature of parerga or incidents in lives otherwise given up to its stern realities, “to interpose a little ease” among the worries of practice, as is illustrated by Sir H. Halford's “*Nugae Metricae*,” mainly composed in his carriage during his professional rounds. To throw

¹ Medical Research Council. Special Report Series, No. 59. A Report on the Occurrence of Intestinal Protozoa in the Inhabitants of Britain. By Clifford Dobell, F.R.S., with Contributions by A. H. Campbell, B.Sc., T. Goodey, D.Sc., R. C. McLean, M.A., Muriel M. Nutt, and A. G. Thacker, A.R.C.S.

¹ *Poetry and the Doctors*. By Charles L. Dana, A.M., M.D., LL.D. The Elm Tree Press, Woodstock, Vermont. 1916. (Pp. 83.)

off some Latin verse may well have been a fashionable and cultured pastime. Thus, in the course of his biographical essay on Elisha Bartlett, the late Sir William Osler writes: "It is remarkable how many physicians write poetry or what passes as such. I have been told of a period in the history of the Royal College of Physicians of London when every elect (censor), as they were called, had written verses." Book-collecting is a hobby not unknown among medical men, and Dr. Dana's example may stimulate some of us to specialize in the poetical works of our colleagues.

It is, indeed, interesting to consider for a moment what kind of poetry mainly appeals to members of our profession in their hours of ease. In attempting to answer this question appeal may be made to *A Physician's Anthology of English and American Poetry*, selected and arranged under eighteen headings by Drs. Casey A. Wood and Fielding H. Garrison.² This collection is devoted neither to poetry by medical men, though they are not excluded, nor to poems on medical subjects. It has been made on the basis of Goethe's view that the only inspired poem is the short occasional one, struck out in a momentary clairvoyance; accordingly, the longer and sustained flights of inspiration, as in Milton and Wordsworth, are not included. In his scholarly foreword Dr. Fielding Garrison points out that from the beginnings of civilization medical men have excelled in serious studies, and that in the generation just past the poets most favoured by them were those who dealt with the ethical and philosophical aspects of life, such as Wordsworth, Shelley, Matthew Arnold, Clough, Lord Houghton, and Emerson; whereas Arnold's poetry seldom appeals to the average successful man. The explanation put forward is that a good doctor's adjustment to life—cheerful, humorous, and friendly in external relations, but austere in the background of his mind—is very like Arnold's own account of the poet's muse. By his calling and contact with disease the doctor naturally tends to become a realist; and escape from the ugliness of life, which reached its climax in the great war, may be afforded him by the finer strains of British poetry. The selections in this anthology begin with those dealing with "Youth and Manhood," and the last three headings are entitled "Tedium Vitae," "De Senectute," and "Divina Mors"; they have kept clear of the hackneyed verses that so commonly appear in anthologies, and are drawn from over a hundred authors, those most in evidence being Arnold, Emerson, Lecky, Tennyson, and Wordsworth. In the section "In War Time" Rupert Brooke's "The Dead" rightly finds a place, but we miss his fine lines on "The Soldier" and also John McCrae's "In Flanders Fields."

This anthology was originally intended as a tribute to the late Sir William Osler on his seventieth birthday, but, although the contents had been approved by him, the volume was not out of the publisher's hands at the time of the death of this beloved physician. Dr. Fielding Garrison has therefore added to his foreword a finely expressed appreciation of "the great liaison-officer of the Anglo-Saxon profession," whose combination of spiritual gravity with attractive humanity amounted to a kind of genius. Though he never wrote verse, Osler by his written and spoken word stimulated his pupils "to recognize the true poetry of life—the poetry of the commonplace, of the ordinary man, of the plain toil-worn woman, with their loves and their joys, their sorrows and their

griefs"; and to him as the great humanist of modern medicine, the friend, inspirer, and encourager of youth, this anthology has been affectionately dedicated.

AN OUTBREAK OF LETHARGIC ENCEPHALITIS.

The number of cases of lethargic encephalitis is increasing in England, and perhaps particularly in London. During November only 4 cases were notified in London; in December 6 or 7 cases were notified in each of the later weeks, and in the weeks ending January 8th and 15th the numbers were 13 and 14 respectively. In the week ending January 22nd, 21 cases were notified, in the following week 29, and in the week ending February 5th, 22. At the same time cases have been reported from various parts of the country—the Isle of Wight, Dorset, Derbyshire, Staffordshire, and Northumberland. A case is reported also from the North of Ireland (co. Armagh). The cases in Staffordshire occurred in the Potteries; four patients there have been under treatment in the isolation hospital, of whom one has died, and several other patients are being treated in their own homes. The two cases in Dorsetshire were from villages widely apart, and it is commonly difficult to trace the source of infection. Nevertheless, in a collection of cases made for the Ministry of Health multiple cases of three and two in the same house were noted, and Dr. A. Salusbury MacNalty¹ has recently presented a report on a remarkable outbreak in August, 1919, at the Rescue and Training Home at Derby. It appears that this explosive outbreak attacked 12 out of 22 female residents, 2 cases arising on August 2nd, 8 in the next three days, and the remaining 2 on August 19th and 27th. In a previous collection of cases made for the Ministry of Health multiple cases of 3 and 2 in the same house were noted, but there is no record of an outbreak such as that at Derby. Nine of the 12 cases, all comparatively young, belonged to the type with general symptoms and ophthalmoplegia, which contains 75 per cent. of the total cases of the disease; 5 of these 9 cases, including the first one, proved fatal, and were exceptionally rapid, with a duration of three to ten days, whereas in the author's previous collection the average duration of the fatal cases was three weeks. From the acuteness and number of the cases it would appear that the virus was highly virulent, and that there was a departure from the usual sporadic to an epidemic form of the disease; it is also possible that the severity of the outbreak was partly due to the youth of these nine patients. The remaining 3 cases were "abortive," and occurred in women aged 40, 34, and 30 years. The source of the outbreak could not be traced, though the presence of an unrecognized "abortive" case or carrier cannot be excluded; no case of encephalitis lethargica, of acute poliomyelitis, or of a similar obscure illness had been recently notified in Derby. The clinical symptoms of the cases corresponded closely with those of encephalitis lethargica, and differed from those described in botulism, and there was no reason to suspect poisoning by belladonna, stramonium, hyoseyamas, or solanum. The pathological report is of particular interest, for microscopic examination of the brain in four of the fatal cases—two by Professors H. M. Turnbull and J. MacIntosh and two by Drs. Da Fano and Helen Ingleby—did not show the lesions characteristic of encephalitis lethargica. But any doubt as to the correctness of the clinical diagnosis are dispelled by Professor MacIntosh's production of a fatal lethargic illness in a monkey by means of intracerebral and intraperitoneal injection of a filtered emulsion of cerebral tissue from the first case, the monkey's brain being found by Professor Turnbull to show the characteristic histological changes of encephalitis lethargica in man. This appears to be the first indisputable occasion upon

² *A Physician's Anthology of English and American Poetry*. Selected and arranged by Casey A. Wood, M.D., and Fielding H. Garrison, M.D. Pages 346. Humphrey Milford, Oxford University Press, London, New York, Toronto, etc. 1920. Price 8s. 6d.

¹ A. Salusbury MacNalty: Appendix vii to the Chief Medical Officer's Report, 1919-1920.

which experimental transmission of encephalitis lethargica to an animal has been successful. The probable explanation of the negative results of examination of the brains of the fatal cases is that the course of the disease was so rapid that there was not time for the characteristic inflammatory changes to appear in the central nervous system.

DISPOSAL OF SURPLUS MEDICAL STORES TO HOSPITALS.

SIR NAPIER BURNETT, on behalf of the Joint Council of the Order of St. John of Jerusalem and the British Red Cross Society, has concluded an arrangement with the Ministry of Munitions for the disposal on favourable terms to hospitals and convalescent homes, and similar institutions supported by voluntary contributions, of the great surplus of medical stores and equipment which have been left over from the war. The part played by the two societies in the transactions will be entirely a voluntary one, and, while the hospitals will have the benefit of the organization and the low prices, the whole of the proceeds will go into the national exchequer. At the present time the stores have been offered for sale along with other surplus goods by the Ministry of Munitions in the usual way, but as the medical stores are mixed up with other goods in the dépôts scattered throughout the country it has been difficult for hospitals and others interested to view them and to obtain them in a satisfactory manner. By the new arrangement the medical stores and accessories have been separated, and they will all be brought to one central dépôt at Shepherd's Bush, London, W. At this dépôt the goods can be inspected by hospital officials, and sales will be effected through the officials of the two societies. The stores that are available for disposal include such medical stores as surgical and dental instruments, x-ray apparatus, drugs, and surgical dressings. Samples will be on view from stores that are included in other departments—such articles, for instance, as hospital beds, furniture, clothing, bedding, ward equipment, trolleys, lockers, and tables. The articles for disposal are all being carefully examined and graded so that the purchasers can be assured that every article which is purchased is fit for use, as goods that are not in a serviceable condition will not be allowed to be included in the sale. The first grade will consist of those stores which are in an absolutely new and first class condition, and the second grade of stores will be those partly used, soiled, or chipped. It is expected that the goods will be ready for sale early in March, and as soon as the work of collecting and grading has been finished, a circular will be sent out to every hospital and similar institution in Britain describing the stores that will be on sale and the time when they will be on view. Each hospital will receive a special card of admission for the inspection of the stores at the dépôt. During the war many hospitals have had of necessity to allow their equipment to run down both in quality and quantity, and this sale of surplus medical stores affords them an excellent opportunity of replenishing it. Although the Ministry of Munitions has invariably carried on its sales on a cash basis, Sir Napier Burnett has been able to have the concession allowed to hospitals of obtaining three months' credit in regard to these purchases. The quantity of material available is very large, as it is estimated that there are £500,000 worth of surplus medical stores in this country alone, while large supplies are still expected from overseas. Hospitals are requested not to make any immediate effort to view or to purchase these goods, as they are not yet ready for inspection, and they will be informed of the actual date when the dépôt will be open. If, however, any hospital authorities eligible for participation in this scheme do not receive a circular by the end of this month, they are requested to communicate with Sir Napier Burnett at the offices of the British Red Cross Society, 19, Berkeley Street, London, W.1.

THE LONDON UNIVERSITY PHYSIOLOGICAL LABORATORY.

THE fate of the Physiological Laboratory of the University of London still hangs in the balance. As was stated a fortnight ago, the Physiological Society has unanimously expressed the opinion that the closure of the laboratory would be a grave injury to the advancement of science and knowledge and to the teaching of physiology in London, and would therefore be contrary to the public interest. We learn from an article by the Director, in *Education*, that the matter will come before the Faculty of Science of the University at its meeting on March 4th. A little over ten years ago the Senate, after receiving identical reports from the academic and internal councils to the effect that "it is highly desirable that the work of the Physiological Laboratory be continued as forming a valuable part of the work of the university," resolved to allocate £800 towards the maintenance of the laboratory. Last December the Senate, because it wishes to use the rooms now occupied by the Physiological Laboratory for its expanding clerical staff, and because the London County Council has suspended its annual grant of £500 a year for the laboratory, resolved that the laboratory should be closed at the end of July next unless the London County Council at once restored its grant. This, we fear, the Council is not likely to do, and unless public scientific and medical opinion can influence the Senate the valuable work which has been carried on unremittingly by the laboratory since it was opened by the Chancellor in 1902, will be brought to an end. Looking back to the last annual report of the Physiological Laboratory Committee, signed by Sir David Ferrier, we find that a great deal of important work was in progress during 1919. In pursuance of the policy proper to a university laboratory of teaching the teacher, courses of advanced lectures are given annually, and last year the Director gave two courses, one on the energy balance of the human body and the other on electric signs of emotive activity. During 1920 the Director pursued his researches on these subjects, and Mr. J. A. Gardner, reader in physiological chemistry in the University, with his assistants, was able to resume lines of research with the prosecution of which the war had seriously interfered; those now in progress are concerned with the digestibility of fats, and in particular with cholesterol metabolism in disease and in infants under various diets. Among other researches undertaken was that by Dr. Burridge on the action of salts, a subject which has a pharmacological bearing, and by Dr. Ellis, the recently appointed lecturer on chemistry at St. Mary's Hospital, on fats. Further, a working anaesthetist has been engaged under the supervision of the Director in the quantitative estimation of chloroform. During last year there were altogether ten workers in the laboratory. We hope, therefore, that in all the circumstances the Senate will reconsider its recent decision and revert to the policy affirmed by it in 1910 and by the Vice-Chancellor, Dr. Robertson, at an earlier date, when he said: "I think the University is too deeply committed to the success of the (Physiological) Department to permit its abandonment except at the cost of a very serious confession of failure, the effect of which on the position of the University would be most injurious."

PUBLIC HEALTH IN CZECHO-SLOVAKIA.

A MEDICAL commission appointed by the Government of Czecho-Slovakia is at present in this country to study public health institutions and administration. On February 14th the commission visited the Central Meat Market and the Fish Market, and were afterwards entertained at luncheon in the Guildhall by Alderman Sir Charles Wakefield, who spoke warmly of the hospitable reception accorded to a civic deputation to the Czecho-Slovak Festival of Freedom last year in Prague. He expressed the hope that, under the direction of Sir George Newman,

the commission had already seen much that interested it, adding that the members of the Sanitary Committee of the City Corporation and Dr. Howarth, medical officer of health, would be anxious to show it the methods adopted for dealing with food control. The London meat market, Sir Charles Wakefield said, is the largest for dead meat in the world, receiving enormous quantities of imported, home killed, and tinned meats, and provisions of all kinds, including green vegetables from the Continent. To regulate, with due regard to the public health, the distribution of these great quantities of food, a huge machinery had grown up and was working with great efficiency. Czecho-Slovakia had recognized that efficient public health administration was one of the tests of a country's civilization. The war had left an evil legacy of special difficulties to Czecho-Slovakia, but that enterprising new country was tackling the problems of public health with characteristic energy. Dr. Halek, speaking on behalf of the Czecho-Slovak Ministry of Health, said that the Commission had found its short study of English public health institutions very encouraging. English civil sanitary administration, like her military sanitation, was unrivalled, and her voluntary hospitals, like her devoted nursing service, were models for others to follow. Sir Charles Wakefield proposed the health of President Masaryk, President of the Czecho-Slovak Republic; the toast was acknowledged by Dr. Mastny, Czecho-Slovakian Minister in this country. Sir George Clerk, British Minister in Prague, spoke in sanguine terms of the future of the Czecho-Slovak Republic. The Commission, which consists of Dr. Vladimir Bazika, Dr. Bohumil Vacek, Dr. Ivan Halek, Mr. Antonin Kolinsky, Dr. Vladimir Petrik, and Dr. Karel Driml, has recently paid a visit to the United States and will spend some time in France on its way home.

EFFICIENCY ON VIEW.

THE average man, conscious of his failure to reach 100 per cent., comes away more depressed than ever from the Efficiency Exhibition now being held in London. Under the roof of Olympia have been gathered mechanical substitutes for most of his mental processes, certainly including those of memory, calculation, and sustained attention, as well as for his physical strength and skill. Here he finds machines which are ready to act as his accountant, his private secretary, his housekeeper, his porter, and also as his candid friend and mentor, checking every motion he makes and almost every breath he draws. At the same time, the detached observer may wonder whether all this brisk efficiency, all this frictionless movement, which eliminates error and reduces the time factor to the minimum, is quite the ideal after which to strive; a little margin of frailty may be Nature's intention for us. It is therefore in certain individual exhibits rather than in general impressions that the leisurely as distinct from the commercial mind will find interest. The University of London illustrates its teaching and research work; Middlesex Hospital the daily routine of its research department, and St. Mary's Medical School the uses of industrial medicine—this last in enforcement of an appeal which is being made for the establishment of a department in that subject at a cost of £60,000. The visitor is also afforded a glimpse of the Metallurgical Department at Sheffield University, and of Armstrong College, Newcastle, where there is an apparatus for determining the liability to explosion of various coal dusts and the inhibitory power of inert dust. Electricity has always stood at the right hand of efficiency, and many of its newer uses are demonstrated at the stand of the British Thomson-Houston Company, where there is also a Coolidge portable x-ray outfit comprising everything necessary for x-ray examination by the bedside. The apparatus can be brought to the house in the doctor's motor-car, carried upstairs, and worked from the nearest lampholder or wall plug. The visitor's eye will

be caught by many other devices, from an improved system of sewage purification to a scheme for artificial daylight, and from the latest form of hygiene propaganda to the construction of ophthalmic lenses. The exhibition remains open until February 26th.

MEDICAL INSTITUTE FOR NEWCASTLE.

IN presenting a Medical Institute to the medical profession in the North of England, Dr. J. W. Smith, of Ryton-on-Tyne, has provided a much-needed want and has raised a memorial—in a form more valuable and holding more promise of keeping green the memory than most memorials—to his son, Dr. J. Wilkie Smith, a young doctor of medicine of great promise who died six years ago. Dr. J. W. Smith, who is an ex-president of the North of England Branch of the British Medical Association and of several other medical societies, is one of the best-known men and represents the finest type of general practitioner of the North; he has shown vision beyond the ordinary in the gift of this medical club. Property was secured at 7, Windsor Terrace, Newcastle-on-Tyne, and alterations were made so as to provide suitable accommodation for a dining-room, lounge, card and billiard rooms, in addition to a library, lecture and committee rooms and bedrooms for country members. The building has been redecorated throughout and the rooms have been tastefully furnished; thus the Institute has an attractive and home-like air, appropriate to its object. On February 10th a large gathering of medical men took place at the Institute, when the presentation of it to the trustees was made by Dr. J. W. Smith. In making the presentation Dr. Smith said that he hoped it would provide not only a social and scientific centre for the profession in the North, but also that the members would not forget the cognate sciences; and he especially remarked on the value of philosophy, literature, and music to medical men in their mission in life. The gift was received by Professor Rutherford Morison on behalf of the trustees; and Professor Drummond, who presided, thanked Dr. Smith in a feeling speech for his munificent and timely gift. Those present were afterwards entertained to tea, and it was agreed that, although the Institute was now open, there should be an official ceremony at an early date to celebrate the event. Intending members should make application to the honorary secretary, Dr. Stanley Robson, at the Institute.

AN AMERICAN FIELD MARSHAL.

THE title of "field marshal of American surgery" was applied by Dr. de Schweinitz to Dr. William Williams Keen on January 20th; the occasion was the celebration of Dr. Keen's 84th birthday, when he was entertained at a banquet in Philadelphia, was presented with a life-size bronze portrait bust, and listened to speeches and poems in his honour. Dr. Keen served as a surgeon during the Civil War in America, and during the great European war; though on the later occasion he did not leave his own country, he did much important work and was gazetted lieutenant-colonel; in the bust he is shown in the uniform of that rank. In the interval between the two wars Dr. Keen attained a commanding position as a surgeon, a teacher, and a writer. His books on the surgery of the brain and of the spine first made his name widely known, and it became a household word in this country after the publication of the great *American Textbook of Surgery*, which he edited in co-operation with the late Dr. William White. During the war he produced a small handbook on the *Treatment of War Wounds*, which ran through several editions. The banquet on January 20th was an assembly remarkable in numbers—for over 600 men and 200 ladies were present—and in the representative character of the attendance. The speakers included the president of the Brown University, where

Dr. Keen graduated in 1859, who said that the outstanding traits in Dr. Keen's character were "a wholesome discontent and a persistent optimism." Dr. William Welch, of Johns Hopkins University, spoke of Dr. Keen's powers as a teacher, and of his great services as a defender of methods of research in medical science. He had earned the gratitude not only of this but of all future generations by successfully combating ignorance, prejudice, and unscrupulousness. We may recall that Dr. Keen embodied his views in a volume entitled *Medical Research and Human Welfare*. Dr. J. C. Da Costa, Dr. Keen's successor as professor of surgery in Jefferson Medical College, gave a short account of Dr. Keen's life. After recalling that when Dr. Keen was born the population of the United States was only 16,000,000 and that of Philadelphia 170,000, while there were only 120 miles of railroad in America, he said that Dr. Keen was foremost among those who changed the crude surgery of the middle of the nineteenth century to the surgery of to-day, and his character was such that his assistants and colleagues at Jefferson Hospital "were his adherents, sworn, true and faithful as soldiers of Napoleon." Mr. D. J. Hill, formerly Ambassador to Germany, and Dr. Keen's friend for five-and-thirty years, eulogized him as a man the whole nation honoured, not only as a surgeon and as a man, but as a servant of his country. Four volumes, containing over 800 letters and telegrams of congratulation from friends, were then presented to Dr. Keen by General Merritt W. Ireland, Surgeon-General of the United States Army. The presentation of the bust was made by Dr. William J. Taylor, President of the College of Physicians of Philadelphia. Dr. Keen, in his reply, said that his professional life covered sixty-one years, forty of which were spent in service as a teacher, a service of which no one not himself a teacher could imagine the joy. If asked the secret of his long life he would reply, "Have some unfinished but not too urgent task awaiting you right outside the door, and you can murder time in the first degree."

FILARIASIS EXPEDITION.

THE London School of Tropical Medicine has arranged to send an expedition to British Guiana to investigate filariasis with the view of obtaining information as to its prevention and treatment. The expedition is being sent at the request, made shortly before he left the Colonial Office, of Lord Milner, who considered that the Government required further advice as to the best method of controlling the disease. At the suggestion of Sir Patrick Manson the expedition will visit also certain West Indian islands, choosing one, such as Barbados, where the rate of attack is high, and another, such as Grenada, where it is low. It is hoped that by comparing and contrasting the circumstances of two such islands light may be thrown on the conditions which favour filaria. The leader of the expedition is Professor R. T. Leiper, director of the helminthology department of the London School of Tropical Medicine; the other members are Dr. G. M. Vevers, demonstrator of helminthology in the School, Dr. John Anderson, Dr. Chung Un Lee, and Dr. Mahommed Khalil of the Egyptian Medical Service. The expedition will sail early next month.

MEASUREMENT OF HUMAN EMOTION.

THE discourse at the Royal Institution on February 4th by Dr. A. D. Waller, F.R.S., the Director of the Physiological Laboratory of the University of London, was concerned with the galvanometric measurement of manifestations of emotion in man. Physiologically all emotions, he pointed out, are expressed as neural outbursts from the central nervous system through efferent nerves to muscles and glands. The manifestations in general were due to intensified physiological activity at the periphery, such as a blush, pallor, a rush of tears, or a dilated pupil. The physical sign of emotion known, since the observations of

Veraguth of Zurich in 1909, as the psycho-galvanic reflex, afforded the most convenient gauge of human temperament, since it declared how much a given subject was moved by his thoughts and feelings. The emotive response was in the main a phenomenon observed in the palm, though it occurred also in the sole. If the hand and the forearm of an ordinary individual were connected with each of two galvanometers and two Wheatstone bridges, the reaction of the arm was steady, while that of the hand was irregular. To a sudden pin-prick, threatened or real, it gave a smart and obvious response. The magnitude of the response in either case varied with different people; in those who might be called "positives" little or no disturbance was caused by the threat, but in those whom he termed "imaginatives" or "sensitives" a large response occurred to the threat, larger, it might be, than to the real pin-prick. The "imaginatives" might be further distinguished into different classes; high in the scale were persons who could at will either keep quiet, or think thoughts, or see imaginary visions or hear imaginary words. To watch the galvanometric signs of these subjective phenomena was very interesting both to the onlooker and to the subject, especially the latter, to whom to sit quietly watching himself think became an absorbing pastime. The emotive response varied in different individuals and in the same individual with different states of mind and body. The distribution of the response over the body was especially interesting. In normal persons it was confined to the palms of the hands and the soles of the feet, but in "sensitives" it extended up the limbs. The few spiritualistic mediums Dr. Waller had been able to examine had, with one exception, given the reaction proper to "sensitives." Diurnal variations of the reaction occurred, the responses being best about the middle of the day, when physiological activity was high. The question had been asked whether pleasant and painful sensations produced similar or opposed galvanometric deflections. The emotive response was a sharp movement and occurred always in one direction—decreased resistance—that is to say, increased permeability. Increased resistance was never observed, but only sometimes diminished permeability. Dr. Waller went on to make a further classification of individuals into (1) "sensitives" or "imaginatives"; (2) "normal," including the majority of men and women; (3) "insensitives," in whom were included hysterical subjects (pythatics); and (4) certain other cases that might be called "super-sensitives"; some shell-shock cases were included in both the third and fourth categories. In concluding his lecture, Dr. Waller said that these cases required further investigation, and that, in fact, no general conclusions could justifiably be drawn from the facts he had put forward until more data had been collected.

THE NEW PARLIAMENTARY SESSION.

OUR Lobby Correspondent writes: But for the fact that the legislative programme of the Government was already to a large extent known, the outline contained in the Speech of the King, on opening Parliament on February 15th, would have been disappointing. No reference whatever was made to health matters, except in so far as a bill to deal with liquor trade administration may be deemed to come within this category. The fact that there is no mention of any measure for the reform of the Poor Law must, it is to be feared, be taken as evidence that none will be introduced this year. On the other hand, the omission of any allusion to the Patent Medicines Bill, the Dentists Bill and to certain important provisions in the Ministry of Health (Miscellaneous Provisions) Bill need not cause serious disquietude if the medical group in the House of Commons do their duty in drawing attention to the urgency of these considerations. The Government having gone so far in these affairs, explicit remark upon them was hardly to be looked for in the Speech from the Throne. Nevertheless, it

would have been reassuring as to the Cabinet's earnestness in this connexion if some comprehensive observation covering this field had been included in the deliverance, since the King speaks on the advice of his Ministers. In the prospect of a shortened and crowded session, some pressure of parliamentary and public opinion may be desirable in order that the measures indicated may get a fair place in the time-table after the financial business—which must have priority—has been dealt with.

EYE-STRAIN IN CINEMATOGRAPH HALLS.

THE London County Council, as briefly stated at the close of an article on the cinematograph in our last issue (p. 234), has adopted the recommendations of the committee appointed by the Illuminating Engineering Society to inquire into eye-strain in cinematograph halls. These recommendations will be put into force at once so far as new halls are concerned, and will be applied to existing halls as opportunity offers. The chief recommendation sets out the limit of the vertical angle of view. The committee believes that ocular discomfort arises mainly from the abnormal angle at which very often the eyes of spectators are directed upwards, and that conditions suitable for the eyes would be secured if a moderate value for the angle of elevation were adopted. It is therefore proposed that the angle of elevation subtended at the eye of any person seated in the front row by the length of the vertical line dropped from the centre of the top edge of the picture to the horizontal plane passing through the observer's eye shall not exceed 35 degrees. In some of the London halls this condition is complied with, and in others it is approached, but in others again the angle in question exceeds 60 degrees.

The summer meeting of the Section of Laryngology of the Royal Society of Medicine will be held on Thursday, June 2nd, Friday, June 3rd, and, if necessary, will be extended to Saturday, June 4th. In addition to the reading of papers, there will be demonstrations on various subjects, an exhibition of instruments, and a museum.

MEMORIAL TO SIR VICTOR HORSLEY.

We published on January 1st a circular letter issued by the general committee formed to establish a memorial to the late Sir Victor Horsley. The intention is, if sufficient support is obtained, to found a lectureship in the University of London by which Sir Victor Horsley's name would be perpetuated.

The first list of subscriptions amounted to £324 17s.; since then the following additional subscriptions have been received:

SECOND LIST OF SUBSCRIPTIONS.

- £105.—Mr. and Mrs. Edward Robinson.
 £20.—Sir F. W. Chance.
 £10 10s.—Mrs. W. S. Coleman, A. H. Burgess, C. H. Carlisle.
 £10.—Miss M. W. Ranken.
 £5 5s.—Sir Berkeley Moyzihan, K.C.M.G., C.B., Sir A. Pearce Gould, K.C.V.O., C.B.E., J. Smith Whitaker, F. J. Hopkinson, Wilfred Trotter, Miss Mary Robinson, Miss Margaret Knowles.
 £5.—Mrs. Scharlieb, C.B.E., M.D., Mrs. Rosa Napier, Miss Emily Chaplin.
 £3 3s.—Sir Thomas Barlow, Bt., K.C.V.O., Sir Humphry D. Rolleston, K.C.B., Harry Platt, M.S., Dr. Thomas Wilson, Mrs. Frances Levy, Dr. Thomas W. Thomas, Dr. W. H. Rivers, Anonymous (per Dr. Collier).
 £2 2s.—Sir William Macdwen, C.B., Dr. E. Rowland Fothergill, Right Rev. Dr. Hine, Dr. May Thorne, Sir S. Squire Sprigge, Mrs. Henry Fawcett, J. H. Morgan, F.R.C.S., Dr. George Pernet, Emeritus Professor James Sully, Dr. J. A. Macdonald, Dr. Edwin Bramwell, J. Fureaux Jordan, J. H. Bown, Professor Halliburton.
 £1 1s.—Lady Rhondda, Dr. Joyce, Dr. Wallace Henry, Professor Keith, Sister Newell, Sister Frinzeanna Low, P. Maude Webbe and A. J. Webbe, Canon J. W. Horsley, Charles W. Beresford Mrs. E. J. Dawson, Miss Juliet Simons, Dr. Herbert Jones, Dr. H. Chick.
 £1.—Miss T. R. Murray.
 10s. 6d.—Mrs. Lindo Henry.
 10s.—George E. Abbot.

In the previous list, p. 19, the name of Sir Cecil Harrison, K.B.E., was incorrectly given.

Subscriptions made payable to "the Victor Horsley Memorial Fund" may be sent to the Honorary Treasurers, Sir Frederick Mott, K.B.E., Maudsley Neurological Hospital, Denmark Hill, S.E.5., and Dr. Howard Tooth, C.B., C.M.G., 34, Harley Street, or the Honorary Secretaries, Sir W. Arbuthnot Lane, Bt., C.B., 21, Cavendish Square, W.J., and Edward J. Domville, C.B.E., Shutes Symonds-bury, Bridport.

ROYAL COLLEGE OF SURGEONS OF ENGLAND.

THE HUNTERIAN FESTIVAL DINNER.

THE Hunterian Festival Dinner of the Royal College of Surgeons of England was held on February 14th—the anniversary of John Hunter's birth—in the library of the College, with the President, Sir ANTHONY BOWLBY, in the chair. H.R.H. the Prince of Wales honoured the College with his presence, and during the evening was formally admitted an Honorary Fellow, and signed the Roll. The Prince was received by the President, the Vice-Presidents, Sir Charles Ballance and Sir John Bland-Sutton, and the Secretary, Mr. S. Forrest Cowell. Four past Presidents of the College—Sir John Tweedy, Sir Henry Morris, Sir Rickman Godlee, and Sir George Makins—were presented. The company, which numbered nearly 100, included the Speaker of the House of Commons, the Marquis of Salisbury, Viscount Hambleden, Lord Lamington, General Lord Horne, the High Commissioners for Canada and New Zealand, the President of the Royal Society, the Presidents of the Royal College of Physicians of London and the Royal College of Surgeons of Edinburgh, the Lord Mayor and Sheriffs of London, the Dean of Westminster, the Treasurers of Gray's Inn and the Inner Temple, the Masters of the Society of Apothecaries and seven other City Companies, the medical heads of the Navy and Army, and Professor Theodore Tuffier of Paris.

The President's Speech.

Sir ANTHONY BOWLBY, in proposing the health of the Prince of Wales, said:

May it please your Royal Highness.—The Royal College of Surgeons of England is the descendant of two civic institutions which date back to the fourteenth century—namely, the Guild of Surgeons and the Company of Barber Surgeons, but it was founded by Charter as a Royal College in the year 1800. It was not, however, until the College celebrated its centenary in 1900 that it became empowered to create Honorary Fellows, and its first Honorary Fellow, Sir, was your illustrious grandfather, King Edward VII, who, while Prince of Wales, was graciously pleased to accept our Diploma in June, 1900. At a later date King George bestowed upon us a similar distinction, and I have now the honour of welcoming your Royal Highness as the third Prince of Wales to become an Honorary Fellow of the College.

Since the election of its first Honorary Fellow the College has from time to time elected other Fellows, and has generally done so in order to commemorate some important event. Following this precedent, it proceeded on July 24th, 1919, to commemorate the close of the Great War by electing six Honorary Fellows from those who had specially distinguished themselves in the war, and it was under these circumstances, Sir, that we requested you to allow us to propose your name. We knew the encouragement that your presence has been at the front; we appreciated your zeal and keenness for everything that benefited our soldiers, and, above all, we admired the spirit in which you performed the duties allotted to you as an officer in His Majesty's army. On the same date we elected His Royal Highness the Duke of Connaught, not only as a representative of the Royal House who had been closely associated with the army all his life, but also because he was the Colonel-in-Chief of that Royal Army Medical Corps which had served with such great distinction, and won for itself such universal praise. We elected Dr. Pierre Duval, the distinguished French surgeon, and Dr. Depage, the equally eminent Belgian professor, both of whom had so closely co-operated with us in the field, and had personally attended many British soldiers. Finally, we elected two representatives of our sister nation, the United States of America, and we chose Brigadier-General Finney, the "Chief Surgeon" to the American army in France, and the Professor of Surgery at Baltimore, and Charles Mayo of Rochester, who had acted as adviser to the Army Medical Service in America, and whose fame is world-wide. The medical professions of Great Britain and of the United States have for many years enjoyed the closest co-operation and friendship, and we were in no way surprised that, as soon as ever the drums of war beat to arms, the surgeons of America sprang to our aid. Within a very few months they supplied the personnel of six general hospitals, and, at a later period, over one thousand of them served in our army in France pending the arrival of their own troops. They served in our base hospitals, in our regiments, our field ambulances, and our casualty clearing stations during the third battle

of Ypres, and amongst them we were especially glad to welcome some of our own Honorary Fellows.

Such, Sir, is a brief record of the claims of the Honorary Fellows elected as representatives of our Allies at the time when you consented to accept our Diploma, and the College has never been more fortunate than in the distinguished names which it has been able to add to its roll at the end of the Great War.

The Royal College of Surgeons performs various public duties which I will not detail. It is the national custodian of the unequalled Hunterian Museum. It possesses a most valuable library open to the whole medical profession, and the Members and Fellows who have passed its examinations number, at the present time, nearly 18,000. Our great master, John Hunter, was the Surgeon-General to the army for some years before his death in 1793, and ever since his time large numbers of men holding our diplomas have served with the imperial forces of the Crown. The present chief medical officers of the Navy, of the Army, and of the Air Force, are all Members of our College, and several thousand of our Fellows and Members served in the late war. Over 350 of these gave their lives for their country, and your Royal Highness knows from your own experience in France that these lives were not given in vain.

We, Sir, in common with all sections of the community, have watched with the deepest interest both the career of your Royal Highness in the war, and also your more recent and invaluable missions to those great British possessions overseas which have so gallantly supported our common cause. We recognize that, both in war and in peace, in France and in the Dominions, you have been a fertile source of inspiration and of good fellowship, and, at the same time, we like to recall that, however far you may have roamed, you have not visited a Dominion or a Colony in which our College was not represented. We may indeed justly claim that, while the heart of our College is in England, our Fellows and Members circulate throughout the world. You, Sir, have been frequently described as "Britain's best Ambassador," but, if I may say so, you are far more than that. An ambassador is but the delegate of a friendly country to a foreign nation, while you are a living and indispensable link in that human chain of common aspirations, common ideals, and common patriotism which binds together all parts of our great Empire in a bond which is infinitely more enduring and unbreakable than all the treaties that ever have been or ever will be written. We use no mere form of words when we say that we fervently trust you may long live in health and happiness to further the good work for the Empire you have so successfully begun. In the name of the Royal College of Surgeons of England, Sir, I beg to thank you most heartily for coming amongst us this evening, and for doing us the honour of becoming an Honorary Fellow.

The Prince of Wales's Reply.

After the Prince had received the diploma and signed the roll of Honorary Fellows of the College, he said:

I thank you very much for bestowing on me, as you did on my father and my grandfather, the Honorary Fellowship of the Royal College of Surgeons of England. I am proud that I should have been elected at the same time as my uncle the Duke of Connaught and four of our distinguished Allies. The College of Surgeons has done splendid work for well over a century. Before the war I think that but few of my contemporaries knew all that the letters F.R.C.S. meant, but the war brought home not only to them but to everybody the full significance and meaning of these letters, and all the long years of successful research and experiment they stand for. Before we went out to the front—I am speaking of my contemporaries—we began to take a practical interest in surgery. Regimental doctors or the doctors of whatever units we were attached to lectured to us. Our female relatives and friends ministered to us and often practised on us, and later on all those who got in the way of a Hun bullet or shell became passive subjects of surgical work. All who served in the war had great or small dealings with your profession and its members, and I have heard nothing but the deepest gratitude expressed towards the medical branches of both Services and those who belong to them, from the surgeons—those who had regular commissions, and thousands (many of them members of this College) who joined up—down to the sick-birth stewards and, in the case of the Army, the orderlies. I include here those eminent surgeons like our chairman, who gave their valuable time, their help, and their advice. Among the

most gallant episodes of the war were those of the unarmed battalion medical officers and their small staffs of stretcher-bearers. The work done by our surgeons and our doctors forms one of the finest chapters in the history of the war. There is no doubt that the fact that the men knew that if they were wounded they were going to be well treated cheered them more than we can understand. It is in this building that so much of the work and the knowledge which made all this possible had its origin. Knowing what that work was, having seen something of it myself, and realizing what is being done here, makes me doubly proud of the honour which has been done me to-night by your having admitted me to your Fellowship.

After the toast of "The Memory of John Hunter" had been honoured standing and in silence, the health of the many distinguished guests who were present to do honour to the science and art of surgery was proposed by Sir Charles Ballance. This toast was replied to by the Speaker of the House of Commons, who praised the good work done by the ten medical members in the present Parliament—"a modern baker's dozen." The health of the Hunterian Orator was proposed in an admirable speech by Sir George Parkin, Administrator of the Rhodes Bequest, who spoke from forty-five years' acquaintance with his fellow Canadian, Sir Charters Symonds, and impressed upon his hearers the importance of the reflex movement of students to Britain from the Dominions.

Scotland.

ASSOCIATION OF SCHOOL MEDICAL OFFICERS OF SCOTLAND.

A CONFERENCE has been arranged by the Association of School Medical Officers of Scotland, to be held on April 7th, 8th, and 9th, in the Provincial Training College, Edinburgh. On the first day a series of lectures will be given: Dr. Shruballs, medical officer to the London County Council, will lecture on "Mental Deficiency," Dr. Norman Walker on "Skin Diseases in Schools," and Dr. MacGillivray, oculist to Dundee Educational Authority, on "The Educationally Blind Child," followed by a demonstration of the methods of education of such children. On the second day of the conference, through the co-operation of the Scottish Board of Health with the association, Professor Dreyer, M.D., of Oxford, will lecture on his recent work on "The Assessment of Physical Fitness," followed by a demonstration of apparatus and methods. This lecture, besides being of interest to medical practitioners engaged in school health work, should also attract medical officers of life insurance companies, and those companies which have offices in Edinburgh are being invited, therefore, to send their medical officers, and other officials interested, to this lecture. In the afternoon of the same day a joint meeting will be held with the Scottish League of Organizers and Teachers of Physical Training to discuss physical education, followed by a demonstration arranged by the Scottish League. On the third day of the conference visits will be paid to special schools and other institutions of interest in Edinburgh. The secretary of the conference is Dr. John Hunter, 8, Abercromby Place, Edinburgh, who will supply any further information which practitioners who are interested might like to have.

GLASGOW ROYAL INFIRMARY.

The report of the managers of the Glasgow Royal Infirmary for 1920 shows an improvement in the finances of the institution compared with the previous year. The managers have completed the year with a surplus of £5,903, and have been able to replace that amount to capital reserves, which were encroached upon in 1919 to the extent of £21,100 to meet the deficiency in revenue that year. This has only been accomplished by applying for revenue purposes all legacies, bequests, and large donations.

The ordinary revenue was £81,725, being an increase of £28,923 over the previous year, and the ordinary expenditure was £116,947, an increase of £18,270. In spite of the continued increase in the cost of commodities and in wages, the deficiency in ordinary revenue was reduced to

£35,221, being an improvement of £10,653. The annual subscriptions showed an increase of £5,187.

The working class contributions were increased by £14,368; this was largely due to the adoption of the method and scale recommended by the Executive Committee of the conference which met to consider how employees of public works might effectively respond to the appeal of the infirmaries and hospitals. The scheme provided for a graduated scale of weekly contributions, with a minimum of 1d. off wages under 30s. per week, 1½d. off wages from 30s. to 40s., 2d. off wages from 40s. to 60s., 3d. off wages from 60s. to 90s., 4d. off wages from 90s. to 120s., 5d. off wages from 120s. to 140s., and 6d. off wages of 140s. and over. The workers periodically allocate the amount collected at the respective works among the institutions they desire to support.

ST. ANDREWS UNIVERSITY.

Professor David Waterston, M.D., has been appointed Adviser of Studies in the Faculty of Medicine at the University of St. Andrews, in place of Professor Herring, who has resigned that post on being appointed Dean of the Faculty of Science and Adviser of Studies in that Faculty.

Correspondence.

WHAT IS A SYMPTOM?

SIR,—I am obliged to Sir James Mackenzie for kindly replying to my question. Sir James gives as a possible definition of a symptom "the reaction of the tissues to an injurious agent." But is not this rather a definition of disease? A symptom I take to be an indication of the existence of disease in the living subject, which is quite a different thing; is it not?

My difficulty is to distinguish between signs and symptoms. We are in need of some term which shall embrace in its meaning evidence, of whatever kind, by means of which the presence of disease can be made manifest during life, whether by electrical and chemical tests, x-ray apparatus, exploratory incisions, or what not.

The term "symptom" is not sufficiently comprehensive for the purpose. In view of this fact and of the ambiguity attaching to the word, why not abandon it in favour of the wholly unambiguous term "sign" (*signum*)?—I am, etc.,

London, W., Feb. 12th.

HARRY CAMPBELL.

X-RAY RADIATION AND CANCER.

SIR,—The letter of Dr. James Willcox is a welcome contribution to this important subject, and I would like to make comment thereon so far as it refers to my letter of January 29th last. The phrase "a promise of a cure" is rather more than I intended to convey. If the word "possibility" is substituted for "promise" I shall be content. Then as to casting an aspersion on our present methods, I certainly did not mean that. These methods have done well, but the science of deep radio-therapy is a progressive one, so that what seems best to-day becomes more or less obsolete at some future time. When I first heard of the method I described it seemed to me so sound in theory as to be well worth investigation on the spot. My experience convinced me that it constitutes a real advance on our methods here, and I lost no time in submitting it to the consideration of my colleagues. I could not well cast aspersion on methods practised by myself until quite recently and not yet entirely abandoned; all the same, we must move with the times.

As for the use of these very hard tubes for therapeutic purposes, it is my considered opinion that, within reasonable limits at least, the harder the better. From the very early days of x-ray therapy I have known from practical experience that hard tubes gave better results than soft ones, but at that time and for some time afterwards I could offer no adequate reason. Even the comparatively feeble filters used at first improved matters, which improvement progressed with the increasing absorption value of the filtering material—all tending towards the production of a more homogeneous beam, more nearly akin to the

hardest gamma rays. The fact that these passed through the tissues so readily led many to suppose that they could be of but limited use, on the theory that only those rays actually absorbed had any biological action. This idea has done much to retard the development of deep therapy in this country and elsewhere. In addition to this, the limitations imposed upon us by our apparatus prevented research with tubes having a resistance above about 9 in. of air. It is probably true to state that only a limited number of radiologists fully realize the wide difference in the principles underlying radiography and radio-therapy. The present day exacting demands of radiography take account only of the primary beam of rays emanating from the anticathode. Low resistance tubes must be used to get the maximum actinism, contrast, and detail; equally important is it to minimize the influence of secondary or "stray" rays. If a hard tube is used we lose not only actinism and contrast, but detail and outline are blurred or lost through the influence of these secondary radiations. Indeed it would appear that their influence increases in more rapid proportion than the hardness of the tube. While it is probably true that the harder the primary beam the less action, *per se*, it has on the tissues it traverses, it more than makes up for this in the profuse amount of secondary radiations set up.

Thus, in radiography the primary beam is all-important; in radio-therapy the chief function of the primary beam is to set up secondary rays in the locality under treatment, such secondary radiations being the principal factor in the changes that follow.

There is evidence to prove the substantial accuracy of these statements, and once realized it is easy to see how we stand to gain by increasing the hardness of our tubes. How far it is possible to go in this direction has yet to be ascertained.

That the filters in common use have too low an absorption value is easily demonstrated. It must be sufficient to make the resultant beam homogeneous; if it falls short of this the disparity between the maximum skin dose and that delivered at any given depth, such as 10 cm. below, is so great that thorough and efficient irradiation of a deeply seated lesion becomes unnecessarily difficult and prolonged. Working with a tube of high resistance (16 m.) no less than 12 mm. of Al, or 0.5 mm. of Zn, are necessary to get homogeneous rays. It is most likely that the same will be required with softer tubes, and such radiation as succeeds in getting through will be small in amount and have a very limited value.

My experience at Erlangen showed unmistakably that the use of a standard type of homogeneous radiation makes for better and more uniform results. As any practical radiologist knows, we are continually being confronted with seeming paradoxes, as instanced in the, at times, widely divergent results in more or less similar cases treated on apparently the same lines. Such are not unknown in the practice of the technique I have described, but they are rare and usually can be accounted for. The system has its defects, of course; we would like to see the time of exposure reduced, as well as the post-radiation sickness, an unpleasant though not serious immediate after-effect. I look for improvement in the use of still harder tubes, but at present it would appear that an equivalent spark gap of 16 in. is as far as it is safe to go, owing to the risk of puncture of the tube itself. If, as it seems, our late enemies have scored a point, we need not despair; let us learn the lesson gratefully and gracefully and then "go one better." British radiologists and British manufacturers may be trusted to rise to the occasion and make good.—I am, etc.,

London, W., Feb. 12th.

REGINALD MORTON.

THE PHYSIOLOGICAL LABORATORY OF THE UNIVERSITY OF LONDON.

SIR.—As a teacher of physiology in a London medical school and as one who has worked in the physiological laboratory of the University of London, I should be grateful for the opportunity of making a few observations on the suggestion that this laboratory should be closed.

The reasons put forward for this, to my mind, retrograde step appear entirely inadequate. Although I find myself quite in accord with the view that the University should give what monetary assistance it is able to research work

in its component colleges, I cannot assent to the proposition that such assistance should be given at the price of the destruction of the University Physiological Laboratory.

Such a laboratory performs a function which no college laboratory, however well equipped, can hope to perform. It forms a centre where the many workers in the various colleges can meet on common ground—it has, in short, a co-ordinating function which is as necessary to university well-being as it is to the life of our bodies. In addition, the laboratory affords most valuable opportunities for the carrying out of certain lines of research, opportunities to do which are, for one reason or another, not available in college laboratories.

The plea that the laboratory should be closed because the space it occupies is needed for administrative purposes surely contains within itself its own refutation. Administration is a necessary part of an efficient university, but it is not its life blood, and that is precisely what research is.

That this laboratory has done and is doing work of the greatest utility cannot be questioned. In this connexion Professor Waller's estimations of the carbon dioxide output of workers in various trades and under various conditions might be quoted as an example of recent activities. These estimations cannot fail to prove valuable contributions to the problem of industrial fatigue, a problem the solution of which holds out a sure promise of increased national efficiency. This work alone should give pause to those who propose to eliminate the Physiological Laboratory of the University of London.—I am, etc.,

B. J. COLLINGWOOD, M.D.,
Physiology Department Medical School,
St. Mary's Hospital, Paddington.

February 15th.

FRACTURE OF THE FIRST RIB.

SIR,—There are a few points in the article on fracture of the first rib, by Messrs. Milligan and Ford, in the *JOURNAL* of February 5th, to which I would like to call attention, in that they tend to perpetuate several fallacies still in the older textbooks.

First, as to the rarity of this accident, Sir Arbutnot Lane pointed out as long ago as 1885, that, far from being exceedingly unusual, evidence of such a fracture was present in 2 per cent. of dissecting-room subjects examined at that time, and he reported many clinical cases of the injury (*Guy's Hospital Reports*, 1885; *BRITISH MEDICAL JOURNAL*, 1887; *Clinical Journal*, 1898, etc.).

Secondly, the authors of the article suggest compression force applied from either end of the rib as a probable method of causation. The breadth of the first rib as compared to its thickness would appear to be a complete mechanical negation of such a theory. Sir Arbutnot Lane showed both experimentally and clinically that the leverage of the clavicle offers a simple mechanical explanation. When the shoulder passes backwards, the clavicle impacts on the first rib at varying points, depending on the plane of its movement. That this is so is shown by the development of an articulation between the two in those habitually carrying heavy weights on the shoulder. If, when in such a position, a blow is struck on the point of the shoulder, one of three things may occur—most commonly a fracture of the clavicle, next in frequency a fracture of the first rib, or rarely a dislocation at the sterno-clavicular joint.

The third point made by the authors is that displacement in fracture of the first rib is quite rare. It is not clear in the text whether bony displacement or displacement of vessels and nerves is meant. If the latter, I would refer them to three cases published by Sir Arbutnot Lane in 1887, where the displacement of vessels simulated aneurysm of the subclavian, and to many others since then. If the former is meant, while it is impossible to criticize without the x-ray picture, I would suggest that the bony tumour they describe is more likely to represent the excessive callus formation which is common in this fracture than actual bone displacement. The so-called protection which the clavicle gives the first rib is a long-lived myth which dies hard; it is, on the contrary, a dangerous and underrated neighbour.—I am, etc.,

London, W., Feb. 9th.

E. G. SLESINGER.

HERPES AND VARICELLA.

SIR.—In your issue of February 12th Dr. Carver, in his interesting records of herpes-varicella infection, states that he has been unable to find any recorded instance in which herpes in one patient has clearly given rise to herpes in another patient. An absolute demonstration of infectivity in many presumed infectious conditions is always difficult. A few days ago I saw a case of this kind in which the coincidence, if it was merely such, was at least suggestive.

On January 28th I was asked to see Mr. X., aged 53, who was suffering from one of the most intense and complete examples of herpes zoster of the right upper fifth nerve which I have ever seen. Curiously enough the amount of pain was and had been comparatively slight. On inquiry, I found that he travelled from Sheffield to London on January 19th, when he spent the night at his sister's house. She was then recovering from an attack of herpes zoster on the trunk. The next day he left London and travelled to Newcastle. Whilst there, on January 22nd, the first symptoms of his attack began by some itching over the right forehead. During the next three days he was out of sorts, slightly feverish, restless at night, and had acute pain in the coracoid hollow on the left shoulder. On the 25th the rash was first noticed, after which it developed rapidly.

Whether the infection had been received during the short time the patient was in his sister's company or not is, of course, quite uncertain. There is, however, a general impression that herpes cases do occur in epidemic-like outbreaks. Ronzier Jolly (quoted in *La pratique dermatologique*, Tome iv, p. 919) recorded the fact that a Parisian suffering from herpes went to stay in a certain small village in Provence. There had been no case of the disease before his arrival. Within six weeks there were seven cases amongst the inhabitants.—I am, etc.,

Sheffield, Feb. 13th.

ARTHUR J. HALL.

SIR,—I have been interested in reading the recent correspondence in the *JOURNAL* and the articles in the issue of February 12th on the association of herpes zoster and chicken-pox, and I should like, therefore, to note the two following cases which have recently come under my care:

1. A woman aged 35 developed herpes on the left leg on December 17th, 1920, and on December 31st her child, who had slept with her, developed chicken-pox.
2. A boy aged 11½ developed herpes round the left side of the chest on January 6th, 1921. On January 20th a brother and a sister started with chicken-pox, and on February 3rd the three remaining members of the family also developed chicken-pox. The only member of the family to escape the chicken-pox was the original patient suffering from herpes.

These cases point to something more than a mere coincidence, and I place them on record merely to add my small quota to the rapidly growing mass of evidence that there is a common causal agent of herpes zoster and varicella.—I am, etc.,

East Cowes, Feb. 15th.

S. HARTILL, M.B. Oxon.

THE PREVENTION OF VENEREAL DISEASE.

SIR,—It seems to me paradoxical that members of the medical profession, who must know and should realize the national danger from venereal diseases and the residuary legacies of those diseases, are so divided upon the ritual of prevention.

I am a Churchman, and I realize how impotent all religious cults have hitherto been even to check the baneful incidence of these diseases. Continence, and the fear of contracting these diseases, have not only failed as preventive agents, but my experience is that those influenced by either of the three, often when they do contract them, either conceal their misfortune or apply to quacks for treatment.

In my opinion the most satisfactory results—as I published in your *JOURNAL*—are attained by carefully explained reasons, and the consistent use of prophylactics. It is far wiser for a father—after pointing out the religious aspect and the advantage of continence—as a good citizen, with a knowledge of human nature, to explain the advantage of prophylaxis should his boy yield to temptation.

As to the instance mentioned some weeks since, of a

mother asking her fourteen-year-old daughter if her prophylactic armament was complete, I would quote the lines of an old hymn:

"Can a mother's tender care
Cease towards the child she bare?"

When religion, continence, and prophylaxis have overcome the awful and lasting effects of the present venereal danger, then, and not till then, should we, as a nation, exclude any and all methods tending to prevention.—I am, etc.,

Folkestone, Feb. 13th.

P. BROOME GILES.

THE NAVAL MEDICAL SERVICE.

SIR,—I am reading with much interest the correspondence to which you are kindly giving the hospitality of your columns. As a very old ex-surgeon R.N. I think it high time the Admiralty descended from their Olympus and agreed to give their consideration to a question which affects a considerable number of efficient loyal officers, and is also of much importance to the Royal Navy generally. "Surgeon Commander" is quixotic, but I fear there is likely to be a substratum of truth in what he says.

I claim to know something of the subject, having served eight and a half years in the R.N. and four years in the R.A.M.C.

Put very shortly, medical officers in the Navy—including the Director-General—have no real authority; in the Navy, quite rightly, authority and discipline mean everything. Promotion is slow and uncertain; the natural result is irritation and discontent. The commander of a ship is often years younger than the surgeon commander; the former is "Please Sir this," "Please Sir that"; the latter "The — old doc." No one can deny this; the younger officers and men are apt to take advantage of it, and a social inferiority is taken for granted.

Again, why are not naval hospitals allowed to fly the white ensign? Any ship's whaler may do so; is a naval hospital of less importance to my lords than a small rowing boat?

I have purposely not touched on the matter of pay and emoluments; let "snobbishness" be officially exterminated, and everything else will automatically improve. We are no longer, as Thomas Gale wrote in the sixteenth century, "a great rabblement there that took upon them to be surgeons. Some were sow-gelders, and some horse-gelders, with tinkers and cobblers." But if I were writing frivolously, the present great discontent in the Naval Medical Service does look as if there were some potential admiral-gelders about.

Seriously, the Admiralty should look into the matter; there must be quite a large number of retired, and therefore independent, witnesses to get some reliable evidence from. It is no good looking to such moribund institutions as the College of Physicians or College of Surgeons for help.—I am, etc.,

GERALD SICHEL, F.R.C.S.,

Late Surgeon R.N., Major R.A.M.C.

Sevenoaks, Feb. 12th.

A NEW SIGN OF PULMONARY TUBERCULOSIS.

SIR,—As Dr. W. J. Hoyten, in the *JOURNAL* of February 12th, has very kindly drawn attention to the fact that lowering of the external end of the clavicle is described in my book on *Pulmonary Tuberculosis in General Practice*, may I say that I have always regarded this appearance as an ancient and well known sign of somewhat advanced or extensive disease? "Depression both above and below the clavicle is now greatly more marked, and may sometimes be really present to a notable amount, but be masked by twisting of the clavicle downwards and inwards on its long axis." The italics are mine, and the quotation is from page 422 of Walsh's *Practical Treatise on the Diseases of the Lung*, 1871. This sign has also been described by foreign authors, ancient and modern; but in our own country there is sometimes a tendency towards the indiscriminate quotation of foreign and often dubious authorities, especially Teutonic, and against the recognition of native writers, dead or living, even to the extent of depriving them of such crumbs of fame as may fall from a bibliographical reference.

There is, however, another sign of pulmonary tuberculosis which, although as old as the disease, has not been described previously, as far as I recollect, in any textbook, but which I have noted in many cases. The sign is *visibility and engorgement of the cephalic vein in the interval between the deltoid and the pectoralis major*. In health the vein is not seen in this place, but when the sign is present the vein is visible throughout its course from the radial end of the dorsal venous arch to the point where it pierces the costo coracoid membrane. This sign is pathognomonic of interference with the venous circulation, from obstruction in the pulmonary capillaries, from diminished intrathoracic suction during inspiration, or from back pressure from the heart, together with wasting of the superficial fat and of the muscles. Consequently, although not an early sign of pulmonary tuberculosis, it may occur in moderately advanced disease, and also in other diseases where the above conditions are present.—I am, etc.,

London, S.W., Feb. 12th.

HALLIDAY SUTHERLAND.

MEDICAL TREATMENT OF ADENOIDS.

SIR,—The interesting letter from Dr. B. G. M. Baskett, on the question of the medicinal treatment of adenoid vegetations as opposed to operation (February 5th, p. 213), calls for certain remarks. I have for years made use of iodine in various forms—such as sodium iodide, potassium iodide, syrup. ferri iod., iodipin, iod-albin, iodoglidine, etc.—in the treatment of a certain class of case of "adenoids."

This is the case in which the chief symptoms manifest are an increased tendency to catch "colds," and the persistence afterwards for two or three weeks of a slight mucous discharge from the nose; there is also usually a tendency to mouth breathing. Iodine will in this class of case, if combined with a change of air to the country or seaside and regular breathing exercises, bring about complete relief. It will be seen that such cases are very slight. Any deafness from Eustachian obstruction, any cervical adenitis or severe and persistent sero-purulent nasal discharge, I regard, quite apart from any other indications, as definite signs that operative interference is needed.

The majority of hospital patients with adenoids—at any rate in this city of Manchester with its damp and dirty atmosphere—would be in no way improved by iodine in any form, and operation is the only possible measure. It is only in slight cases that the exhibition of iodine is useful, and here only when the patient may also be placed under good hygienic conditions—and such cases ought to be seen from time to time, as the incidence of an infective fever such as measles or scarlet fever, or of that form of infective nasal catarrh or "sore throat" which seems to attack schools, may bring about such an increase in the size of the adenoid vegetations and in the symptoms generally that operation will now be necessary.

In my experience iodine, although definitely useful in cases of "adenoids," has very definite limitations to its curative value.—I am, etc.,

Manchester, Feb. 10th.

LINDLEY SEWELL.

NASOPHARYNGEAL CATARRH AND TUBERCULOSIS.

SIR,—Surgeon Commander Given, in his paper "Deductions from the statistics of pulmonary tuberculosis," published in your last issue, has called attention to an important factor in the causation of pulmonary tuberculosis when he brings into well deserved prominence the frequently preceding catarrh of the nasopharynx.

In dispensary work one finds that out of an average annual number of 1,000 new cases sent for examination, more than 80 per cent. are suffering from nasal obstruction. Even if there are no signs of external catarrh each nostril should be separately examined, and this examination should not be confined to chest cases, for it is seldom that a "hip" or "spine" does not give a history of previous nasopharyngeal infection.—I am, etc.,

Newport Mon., Feb. 15th.

J. LEWIS THOMAS.

Obituary.

JAMES CHARLES McWALTER, M.D., LL.D.,
HIGH SHERIFF OF DUBLIN.

As briefly announced in our last issue, Dr. J. C. McWalter, of Dublin, died suddenly at his residence in North Circular Road in the early morning of February 5th, at the age of 53. On the previous evening he had attended a meeting in Merrion Square which lasted until after 9 o'clock, and when the members dispersed Dr. McWalter's last tramcar had gone. He made a great effort to reach the other side of the city on foot before curfew, and entered his house in a state of exhaustion. The news of his death caused a painful sensation among all classes of citizens in Dublin.

Educated at the Christian Schools and the Catholic University of Dublin, Dr. McWalter qualified with the licence of the Royal College of Surgeons in Ireland and of Apothecaries' Hall, Dublin, in 1897, taking the D.P.H. in 1900. Later in his career he graduated M.A. and M.D. of Trinity College, Dublin, and M.A. of the Royal University of Ireland, and he obtained many other degrees and distinctions in arts and medicine, both at home and abroad. In 1907 he was called to the Irish Bar, and the degree of Doctor of Laws, both of the National University of Ireland and of Ottawa University, was later conferred upon him.

Dr. McWalter took a prominent part in public life. He was a member of the Senate of the National University of Ireland, a member of the Royal Irish Academy, and had been a governor of Apothecaries' Hall. He was an alderman of the Dublin Corporation and he was appointed High Sheriff of Dublin in 1920. In politics he was a Constitutional Nationalist, who did not conceal his dislike of Sinn Fein. During the great war he served with the R.A.M.C. in the Mediterranean area, retiring with the rank of captain. He was the author of several publications, including a history of the Irish Apothecaries' Hall, and he wrote a great many articles and letters, especially on problems of public health.

A regular attendant at the annual meetings of the British Medical Association, he was vice-president of the Section of Pharmacology and Therapeutics at the annual meeting at Aberdeen in 1914; he was vice-president of the Leinster Branch of the Association. Some years ago he married the daughter of Mr. John Crowley of Clontarf, and she has received messages of sympathy from all parts of the city and of Ireland.

Dr. McWalter's interests were as varied as his character was many-sided; he was known in every circle in Dublin, but more especially among the poor of the city, who have lost in him a generous champion and helper. Modest and unassuming, ever moving about, though without fuss or apparent anxiety; gentle and kindly towards patients or callers as towards opponents in controversy, he was for years one of Dublin's outstanding citizens. In politics, as in everything else, he was outspoken and straightforward, and those who differed from him always acknowledged his transparent sincerity. The writer of a character sketch in the *Irish Independent* describes McWalter as belonging to a type that is fast becoming extinct in Ireland—a type prevalent a quarter of a century ago, but rare to-day—original, elusive, many-sided; of sound common sense one moment, annoying the next, amusing now, bitter then; but taking him all round, whether in or out of one of his moods, a sincere and delightful personality. As a controversialist he was better on paper than in debate. National life was barren in his young days, so he turned to words and allowed his passion for them to overmaster him. "He wrote hard and he spoke hard, yet on the day of his death he had not a personal enemy in all Ireland."

Dr. ROBERT HARRIS, of Southport, died on February 5th, aged 73. He was educated at University College, London, and later at Guy's Hospital. He took the diplomas of M.R.C.S. and L.R.C.P.Lond. in 1869, and graduated M.B.Lond. in 1872. After practising for fourteen years in London in partnership with his father, he removed to Southport, where he continued to practise his profession until his retirement some thirteen years ago. He took great interest in the work of the British Medical Association, and had served as secretary of the Southport Division, and as a member of the council of the Lancashire

and Cheshire Branch, of which he was appointed president in 1918-19. He was an ex-president of the Southport Medical Society. In recognition of his services to the medical profession the local practitioners in 1914 presented him with a silver salver and Mrs. Harris with a silver teapot. Since his retirement from practice Dr. Harris took great interest in public affairs, was appointed to the Commission of the Peace for the borough in 1917, and was a regular attendant on the bench.

WE regret to announce the death, at the early age of 43, of Dr. THOMAS GEORGE MILES, of Ruardean, Gloucestershire, which occurred from acute pneumonia on February 4th. Dr. Miles's practice was a large one, covering a wide district in the Forest of Dean, and he was attending patients up to the day before his death. The son of a doctor, Dr. Miles was educated at Guy's Hospital, and was a house-surgeon in Plymouth and in practice in Lancashire before coming to Ruardean twelve years ago. He was local secretary of the Forest of Dean Division of the British Medical Association, and took a large share in the public work of the district. He was a member of the Gloucestershire County Council and of the County Insurance Committee, a keen sportsman, who was until recently honorary secretary of the local Rugby Football Combination, a prominent Freemason, and a high office-bearer in the Order of Buffaloes, an order in which Dr. Miles took a special interest. The widow, who has received many marks of sympathy, is left with three children.

The Services.

DEATHS IN THE SERVICES.

LIEUT.-COLONEL HENRY PEERS DIMMOCK, Bombay Medical Service (retired), died at Sydenham on January 23rd, aged 64. He was born on January 16th, 1857, the son of the late James Augustus Dimmock, bank agent, Ely, educated at St. George's, and took the diplomas of M.R.C.S. and L.R.C.P.Lond. in 1879; subsequently graduating as M.D.Durb. in 1898. He entered the I.M.S. as surgeon on March 31st, 1880, became Lieut.-Colonel after twenty years' service, in 1900, and retired, with an extra compensation pension on April 15th, 1911. His first seven years' service was in military employ, during which he served with the 2nd Biluch Infantry, on the North-West Frontier of India, in the Marei expedition of 1880-81. Entering civil employ in September, 1887, after four years in various stations, he was appointed obstetric physician of the Jamsetji Jijibhai Hospital, Bombay, and professor of midwifery in the Grant Medical College, Bombay, in June, 1891; and twelve years later, in November, 1903, he became also principal of that college. He rejoined for service in the recent war from August, 1916, to 1918, and was appointed commanding officer of the Holborn Military Hospital, Mitcham, containing 1,000 beds, for which he was awarded the O.B.E. in June, 1919. His strenuous work during that period put a heavy strain upon his health. When plague broke out in Bombay a quarter of a century ago, he served as a member of the special plague committee in that city from March, 1897, to May, 1898. He was the author of a small work on cerebro-spinal meningitis in Indian gaols.

Universities and Colleges.

UNIVERSITY OF MANCHESTER.

MR. ARTHUR H. BURGESS, M.B., M.Sc., F.R.C.S., surgeon to the Manchester Royal Infirmary, and lately Lecturer on Practical Surgery in the University, has been appointed Professor of Clinical Surgery.

ROYAL COLLEGE OF SURGEONS OF ENGLAND.

AN ordinary Council was held on February 10th, when Sir Anthony Bowlby, President, was in the chair.

Issue of Diplomas.—Diplomas of membership were granted to the candidates found qualified at the recent examinations, whose names were published last week (p. 252) in the report of proceedings of the meeting of the Royal College of Physicians.

Diplomas in Ophthalmic Medicine and Surgery were granted to seven candidates (BRITISH MEDICAL JOURNAL, February 5th, p. 214).

Central Midwives Board.—Dr. W. S. A. Griffith was reappointed to represent the College on the above Board for the period of one year from March 31st, 1921.

Election of Four Members of Council.—The President reported that a meeting of the Fellows would be held at the College on Thursday, July 7th, for the election of four Fellows into the Council in the vacancies occasioned by the retirement in rotation of Sir George H. Makins, Mr. J. Ernest Lane, Mr. H. J. Waring, and Mr. F. F. Burghard; that notice of the meeting

would be given to the Fellows by advertisement and by circular on March 11th; that March 21st would be the last day for the nomination of candidates; and that a voting paper would be sent on April 5th to every Fellow of the College whose address is registered at the College.

Medical News.

ON Monday next, February 21st, at 5.30 p.m., a meeting will be held at the house of the Royal Society of Medicine, to hear statements as to medical education in China. Sir Donald MacAlister, President of the General Medical Council, will be in the chair, and Mr. Harold Balme, F.R.C.S., Dean of the Faculty of Medicine of the Shantung Christian University, Tsinan, will give an address. The American Ambassador hopes to be present, and the new Chinese Ambassador will be represented by Mr. Owyang King, First Secretary of the Legation. Among others who hope to be present are the Right Hon. Sir Clifford Allbutt, K.C.B., President of the British Medical Association, Sir Alfred Pearce Gould, Sir Francis Champneys, Bt., and Sir John Jordan, formerly British Ambassador in Peking.

THE Council of Epsom College will shortly award "France" Pensions of £30 a year to aged medical men in necessitous circumstances, as well as a St. Anne's Home Scholarship to the orphan daughter of a medical man between the ages of 9 and 12. Full particulars can be obtained from the secretary, Mr. J. Bernard Lamb. An announcement appears in our advertisement pages this week stating that applications for admission of candidates for pensionerships and foundation scholarships at Epsom College, and for an examination for the admission of boys as Council Exhibitors, who pay 50 guineas a year for education and board instead of 100 guineas, the usual fee, must be received at the office, 49, Bedford Square, London, W.C.1, by the morning of March 2nd.

IN view of statements which have appeared in the lay press with regard to an influenza epidemic, we are informed by the Ministry of Health that, whereas for the week ending February 7th, 1920, the number of deaths from influenza in ninety-six great towns of England and Wales was 98, the number for the corresponding week of the present year—the week ending February 5th, 1921—in the same ninety-six towns was only 61. The number of cases in the week ending December 25th in the ninety-six great towns was 81, in the following week it was 89, and in the week ending January 8th it was 101; since then it has declined to the figure above mentioned. There is a sporadic outbreak of influenza at Aldershot.

A COURSE of twelve lecture-demonstrations on gonorrhoea will be given by Mr. E. R. T. Clarkson and Mr. Malcolm Simpson (Chief Assistants to the Genito-Urinary Department of the hospital) on Tuesdays, Wednesdays, Thursdays, and Fridays, at 4.30 p.m. in the Venereal Out-patient Department of the London Hospital, beginning Tuesday, March 1st. Members of the medical profession are invited to attend.

A MEETING of the medical practitioners in Bradford was held on February 10th to consider the report of the Local Medical Advisory Committee upon the scheme for the administration of St. Luke's Hospital, Bradford, as a municipal general hospital. The committee reported that the scheme before it appeared to aim at establishing a municipal hospital of such magnitude that it would lead to the extinction of the existing voluntary institutions, and expressed the view that the present is an inopportune time to launch an elaborate and costly scheme such as the medical officer of health proposes. The committee's detailed report was approved by a large majority.

ON the occasion of his retirement from practice in Newton Stewart, Wigtonshire, Dr. N. J. McKie, who has been in practice there for over thirty years, was made the recipient of a public testimonial, his wife and family also being included. Dr. McKie was formerly vice-chairman of the Border Counties Branch of the British Medical Association, and has been well known as a successful practitioner. He is a prominent Freemason, and on the occasion of his leaving the district the local masonic lodge, "St. Ninian" 499, took the opportunity of presenting him with a valuable past master's jewel.

At a meeting of the Royal Sanitary Institute, on Friday, February 25th, at the College of Technology, Manchester, discussions will take place on "The use of open fires for domestic heating," opened by Dr. Margaret Fishenden, and on "Air pollution," opened by Professor J. Radcliffe. At 90, Buckingham Palace Road, London,

S.W., on Tuesday, March 8th, at 5 p.m., the Institute will again meet, and discussions on "The sanitary engineering side of town planning" and "Town planning of built-on areas" will be opened by Mr. Edward Willis and Mr. George Pepler respectively.

A MEETING of the School Medical Service Group of the Society of Medical Officers of Health will be held this day (Saturday, February 19th), at 11.30 a.m., at 1, Upper Montague Street, Russell Square, London, W.C. Among the subjects for discussion are uniformity of medical inspection cards and schedules, and superannuation and security of tenure. Members of the School Medical Service who are not members of the society will be welcome as visitors. The honorary secretary is Dr. Armlly Ashkenny, Health Department, West Bromwich.

THE annual meeting of the Mental After-Care Association for poor persons convalescent or recovered from institutions for the insane will be held on Wednesday, February 23rd, at 3 p.m., at Bridewell Royal Hospital, New Bridge Street, E.C. The chair will be taken by Sir Charles Wakefield, President of Bridewell and Bethlem Royal Hospitals, and the speakers will be the Bishop of Barking, Sir William Byrne (Chairman of the Board of Control), the Hon. John Mansfield (Lord Chancellor's Visitor in Lunacy), and Dr. Nathan Raw, M.P.

THE annual congress of the Ophthalmological Society of the United Kingdom will be held on May 5th, 6th, and 7th, at the Royal Society of Medicine, 1, Wimpole Street, W.1. The President, Mr. J. Herbert Fisher, will give his opening address on Thursday, May 5th, at 10 a.m.

MR. GEOFFREY JEFFERSON and DR. A. H. HOLMES have been appointed lecturers on clinical anatomy at Manchester University, the former to deal with the surgical and the latter with the medical aspects of the subject.

SIR NAPIER BURNETT, K.B.E., M.D., has been appointed chief executive officer of the Joint Council of the British Red Cross and the Order of St. John.

AT the sitting of Lord Cave's Committee of Inquiry into Hospital Finance, held on February 9th, evidence was given by Mr. Gilbert G. Panter (Secretary) on behalf of the Committee of Management of the Great Northern Hospital.

DR. GUSTAVE MONOD, M.R.C.P., of Vichy, will demonstrate on Wednesday next, February 23rd, at 5 p.m., at the Royal Society of Medicine a series of films in which the rate is retarded in the manner found useful for the study of movement, including the walk of men suffering from various forms of war injuries and the wearers of artificial limbs. The films Dr. Monod will show will include one on the cardio-pulmonary circulation obtained in Professor Carnot's laboratory, another giving an analysis of golf shots made at the Institut Marey, Paris, and a third exhibiting various athletic movements. Dr. Monod brings with him a message from the Association pour le Développement des Relations Médicales of the Paris Faculté de Médecine. The hope is that a definite entente may be established between the French and British professions through the association in Paris and the Fellowship of Medicine in London.

THE London County Council retains the services of three medical men for the purpose of medical examinations in connexion with claims arising from tramway accidents. Each is paid a retaining fee of £42 a year, 10s. 6d. for each examination within the county, £2 2s. for each attendance at court to give evidence, and a special fee, based upon distance and time, for examinations outside the county. The time having come for a revision of the arrangement, these medical men asked that the increase of 50 per cent. in the retaining fee granted three years ago should be applied to the other fees, in view of the increased cost of postage, telephone, travelling, etc. The Council on February 1st decided not to alter the retaining fee nor the fee of £2 2s. a day for attendance in county courts, but to increase by 50 per cent. the fee of 10s. 6d. for each examination and the fee of £2 2s. a day for attendance in the High Court.

THE Great Northern Central Hospital has graded its accommodation into three sections, comprising 140 beds in the general wards, 62 beds in the contributory wards, and 18 beds in the private wards. In the general wards necessitous cases are admitted free, but patients who can afford to do so give from 1s. to 20s., according to circumstances. The contributory wards are intended for those unable to meet the full expenses of medical service and nursing at home, and they give, while in the hospital, from £1 1s. to £4 4s., according to their means, as assessed by the committee. The treatment of patients in the general and contributory wards is undertaken gratuitously

by the honorary medical staff. The private wards, which have just been inaugurated, are intended for the benefit of patients whose means do not allow of the payment of the usual medical and surgical fees, but who are willing to contribute towards the cost of medical services and maintenance while in hospital. The payments range from 4½ to 6 guineas per week, with a fee for medical service of £1 ls. per visit—maximum fee for medical service, £3 3s. per week. In the event of an operation a charge of £5 5s. will be payable, which will cover the reduced fees of the surgeon and the anaesthetist, and the charge for the use of the theatre. By arrangement with a member of the honorary medical staff and the patient concerned, private practitioners may attend the hospital to share in the treatment. The patient in this case pays the local medical practitioner's fee. In assessing the amount payable by patients the committee will arrange for a rebate of 50 per cent. off the medical fees where the income is the minimum for the private wards, or exceed the minimum up to £100.

Letters, Notes, and Answers.

As, owing to printing difficulties, the JOURNAL must be sent to press earlier than hitherto, it is essential that communications intended for the current issue should be received by the first post on Tuesday, and lengthy documents on Monday.

ORIGINAL ARTICLES and LETTERS forwarded for publication are understood to be offered to the BRITISH MEDICAL JOURNAL alone unless the contrary be stated.

CORRESPONDENTS who wish notice to be taken of their communications should authenticate them with their names—of course not necessarily for publication.

AUTHORS desiring reprints of their articles published in the BRITISH MEDICAL JOURNAL are requested to communicate with the Office, 429, Strand, W.C.2, on receipt of proof.

In order to avoid delay, it is particularly requested that ALL letters on the editorial business of the JOURNAL be addressed to the Editor at the Office of the JOURNAL.

THE postal address of the BRITISH MEDICAL ASSOCIATION and BRITISH MEDICAL JOURNAL is 429, Strand, London, W.C.2. The telegraphic addresses are:

1. EDITOR of the BRITISH MEDICAL JOURNAL, *Aitology*, Westrand, London; telephone, 2630, Gerrard.
2. FINANCIAL SECRETARY AND BUSINESS MANAGER (Advertisements, etc.), *Articulate*, Westrand, London; telephone, 2630, Gerrard.
3. MEDICAL SECRETARY, *Medisecra*, Westrand, London; telephone, 2630, Gerrard. The address of the Irish Office of the British Medical Association is 16, South Frederick Street, Dublin (telegrams: *Bacillus*, Dublin; telephone, 4737, Dublin), and of the Scottish Office, 6, Rutland Square, Edinburgh (telegrams: *Associate*, Edinburgh; telephone, 4361, Central).

QUERIES AND ANSWERS.

INCOME TAX.

"G. D. M." bought his practice in March, 1919. He asks whether he can be assessed for 1919-20 on the average of his own earnings as a surgeon lieutenant in the navy over the three previous years.

*. No; the legal basis of assessment is the average profits of the purchased practice over those three years, subject to the proviso that "G. D. M." can apply to be assessed on the earnings of the year 1919-20 if the profits have fallen short from some specific cause since or by reason of his succession to the practice.

"J. L. D." bought a car for professional use in 1914 for £250, and sold it for £200 on joining the army; he has since claimed to deduct £350 cost of renewal, as he has paid £550 for a car no better than the one purchased in 1914 for £250. The Income Tax Commissioners refuse to allow the £350 without giving any reason.

*. Our correspondent's claim appears to be in accord with the principle and specific examples expounded by Mr. Hopkins, an official witness, before the Royal Commission on Income Tax. We advise "J. L. D." to point this out to the local inspector of taxes, and to ask for reconsideration of the question. The appeal lies to the local or special Commissioners of Taxes, provided that the assessment was objected to within twenty-one days of the receipt of the notice of assessment.

"MEDICAL INSPECTOR" inquires as to the expenses deductible from the Schedule E assessment on his stipend.

*. Expenses incurred wholly, exclusively, and necessarily in the performance of the duties of the office can be deducted provided that they are not of a capital nature. It is impossible to give a categorical reply without knowledge as to the precise conditions of the appointment and the degree of

assistance, if any, given by the authority—for example, the provision or otherwise of a medical reference library. *Primâ facie*, the expenses mentioned are allowable to the extent to which they are actually laid out in the year in the maintenance, but not the original provision or improvement, of our correspondent's essential equipment.

"INQUIRER" purchased a practice for a certain sum, which he is paying off in annual instalments. He asks whether he can deduct the payments from his practice receipts for income tax purposes.

*. No; the payments are none the less of a capital nature because they are being spread over a more or less lengthy period instead of being made in a single sum.

LETTERS, NOTES, ETC.

THE writer of the obituary notice of the late Dr. F. H. DAYUS, printed in the JOURNAL of February 12th, stated that Dr. Dayus "shared with Dr. Dain, of Birmingham, the distinction of being one of the two medical chairmen of Insurance Committees." We now learn that Dr. R. Harding and Dr. E. J. Maclean have long been chairmen of the Radnorshire and the Cardiff Committees respectively; and there may be other medical chairmen of Insurance Committees.

"INCITAMIN."

IN our issue of January 29th (p. 179) we replied at some length to an inquiry regarding incitamin, an organic preparation devised by Professor Fischer of Copenhagen for the treatment of wounds and ulcers. The latest contribution to the spirited discussion of this topic in our Danish contemporary *Ugeskrift* is a letter from Dr. E. Himmelstrup in the number for January 20th. He points out that Professor Fischer's paper on this subject suggested an uninterrupted series of successes; at any rate no mention was made of failures. Yet the one case Dr. Himmelstrup has been able to investigate was an utter failure as far as treatment with incitamin was concerned. The patient had suffered for several months from severe and extensive x-ray ulceration. Neither the pain nor the ulceration was affected by the prolonged use of incitamin.

SUPERNUMERARY NIPPLES.

DR. EDMUND CAUTLEY (London, W.) writes: In reply to Dr. Skerrett's inquiry in last week's JOURNAL, polythelia (supernumerary nipples) is not uncommon, and is often associated with polymastia, which is said by Iwal to be present in 5.19 per cent. of Japanese women and in 1.6 per cent. of the men. It is less common in this country. During pregnancy such nipples may become more prominent and more readily erectile. If mammary tissue is also present, pricking and other sensations are felt, as in the normal breast, and turgescence occurs. Occasionally polymastia is the result of dichotomy of a single gland, or is a spontaneous variation. The peculiarity runs in families and is usually transmitted by females. In Dr. Skerrett's patient transmission was paternal.

DR. D. H. VICKERY (Ministry of Pensions Hospitals, Neath, Glam.) writes with reference to Dr. Skerrett's note on supernumerary nipples (February 12th, p. 254): The rarity consists more in finding them well developed. Recently at an operation this condition was noticed in a man, and the development was so advanced I had a sketch made. The areolae were exceptionally developed and were studded with hairs. Anyone interested in the matter can gladly have this life-like sketch for inspection.

VACANCIES.

NOTIFICATIONS of offices vacant in universities, medical colleges, and of vacant resident and other appointments at hospitals, will be found at pages 34, 35, 38, 39, and 40 of our advertisement columns, and advertisements as to partnerships, assistantships, and locum tenencies at pages 36 and 37.

SCALE OF CHARGES FOR ADVERTISEMENTS IN THE BRITISH MEDICAL JOURNAL.

	£	s.	d.
Six lines and under	0	9	0
Each additional line	0	1	6
Whole single column (three columns to page)	7	10	0
Half single column	3	15	0
Half page	10	0	0
Whole page	20	0	0

An average line contains six words.

All remittances by Post Office Orders must be made payable to the British Medical Association at the General Post Office, London. No responsibility will be accepted for any such remittance not so safeguarded.

Advertisements should be delivered, addressed to the Manager, 429, Strand, London, not later than the first post on Tuesday morning preceding publication, and, if not paid for at the time, should be accompanied by a reference.

NOTE.—It is against the rules of the Post Office to receive *post-restante* letters addressed either in initials or numbers.

An Arris and Gale Lecture
ON
THE FUNCTION OF THE KIDNEYS
IN ENLARGEMENT OF THE
PROSTATE GLAND.

DELIVERED BEFORE THE ROYAL COLLEGE OF SURGEONS
OF ENGLAND.

BY
J. F. DOBSON, M.S., F.R.C.S.,

HONORARY SURGEON TO THE FIELDS GENERAL INFIRMARY, ETC.

The operation of prostatectomy for simple enlargement of the prostate has attained an established position in the treatment of this disease. It is attended in many cases with the most satisfactory results, but a study of the published statistics of the operation, of the results painted as they are in such rosy colours, might lead one to suppose that any man suffering from this affection could undoubtedly be cured, and cured completely, by an operation entailing little risk, a minimum of discomfort, and no troublesome sequelae.

But this is not a very accurate presentation of the facts. It is true that Sir Peter Freyer has been able to publish results showing, in the latest series of cases, a mortality of 3 per cent. In a very interesting and comprehensive review on the subject of prostatectomy which appeared recently it is stated that experience leads to the conclusion that to reach the success attained by Freyer there must be the most rigid selection of cases. Outside of the select cases complications arise which induce a mortality of 15 to 25 per cent. Surgeons of experience in this operation will agree with these statements. It is clear that to obtain a low mortality—not altogether the most desirable object of the surgeon—the possible benefits of the operation must be withheld from a considerable number of sufferers. Particularly favourable results can be obtained in patients who are almost entirely above the hospital class; such patients, usually educated men, seek advice—and good advice—at an earlier stage of the disease; they have more courage to face the problem which presents itself, and they are therefore operated upon at an earlier stage than the average hospital patient. The bladder is less frequently infected, and they do not so commonly suffer from impaired renal function.

PROPORTION OF OPERABLE CASES.

It is extremely difficult to ascertain what proportion of sufferers from enlarged prostate requiring relief are submitted to prostatectomy; no figures on this point are available. Steiner says he operated on 70 out of 180 cases he had seen. Inquiry from a good many surgeons reveals some discrepancies. Most agree that a considerable proportion are unsuited for prostatectomy. I am not able to give my actual figures, but I think I operate upon about 75 per cent. of my cases. I find the percentage of cases on which I do the operation is rising fairly rapidly.

This low proportion of operable cases is mostly among hospital patients, and it is particularly among these patients that the operation is so necessary. If catheter life is resorted to in the case of a wealthy, leisured, and educated man, the utmost precautions and the greatest care are necessary if an early disaster from infection is to be avoided. In the case of an elderly working man it is practically impossible to carry out regular catheterization with success. Only too frequently, however, when he presents himself for treatment he is found to be suffering from some complication which either precludes the operation or renders it extremely dangerous.

COMPLICATIONS OF PROSTATIC ENLARGEMENT.

The complications which deny these patients the possible benefits of prostatectomy may be considered under the following four headings:

1. Cases of Impaired Renal Function due to Back Pressure without Infection of the Urinary Tract.

These cases (Cases 1 and 2) are not at all uncommon in educated men, but are rarely met with in the hospital class. The patients present themselves with a markedly distended bladder, perhaps with complete retention, or

merely complaining of increased frequency. They are not infrequently anaemic, the tongue is dry, and they complain of headache, thirst, and sometimes vomiting. The urine is of low specific gravity, the urea percentage is low, and there is generally some albumin present without pus or organisms. Culture is sterile. If submitted to prostatectomy they almost invariably die from uraemia. Thomson Walker says: "There is no more dangerous class of case in urinary surgery." Examination of the organs in such cases reveals dilated and tortuous ureters with patent orifices, dilated pelvis and calyces in the kidneys, and thinning and fibrosis of the kidney tissue. Such cases are rarely met with among hospital patients because they have usually been catheterized and infected.

These cases are very deceptive. The slowly progressing enlargement of the prostate causing back pressure and impaired renal function may cause very little in the way of local symptoms, possibly only some frequency without pain, haemorrhage, or retention. The careful surgeon in such a case is apt to decline prostatectomy. Catheter life is started, and sooner or later—usually sooner than later—infection occurs and the patient dies rapidly.

2. Cases of Infection of the Urinary Tract.

The infection may be limited to the bladder or may have extended upwards to the kidneys, producing a greater or lesser degree of pyelonephritis. Minet describes renal infections in these cases under three headings:

1. Pyelonephritis of moderate degree. Cases characterized by a moderate degree of chronic pyuria, without fever, without signs of toxæmia, and without notable alterations in the chemical composition of the urine. In these cases there is no impairment of renal function, and they are suitable for prostatectomy.

2. Pyelonephritis of moderate degree with exacerbations, chronic pyuria with recurring attacks of fever, toxæmia, haematuria, etc.

3. Infection with Definite Impairment of Renal Function.

Minet's last class comes under this head. In these cases the impaired renal function is the result of a series of exacerbations over a more or less lengthy period. In these cases the kidneys are both distended and infected—distended on account of ureteral obstruction by distension, lengthening, and kinking of the ureter, or by swelling of the mucosa and thickening of its walls. This condition of septic renal retention is evidenced clinically by fever, renal pain, and enlargement and tenderness of the kidneys, and is usually fatal.

4. General Organic Disease.

I do not propose to consider here the difficulties caused by serious organic disease in other parts of the body.

The principal reason for the rejection of cases and for the failure of the operation is impairment of renal function associated or not with infection. The degree of impairment of renal function may be estimated by various methods, first by clinical signs alone. There can be no doubt that the very astute clinician can, without any elaborate investigation, form a very good opinion as to the suitability of a given case of enlarged prostate for operative treatment. The appearance of the patient, the presence or absence of anaemia, the state of his tongue and appetite, consideration of the temperature, sleep, pain, etc., are all valuable guides. Examination of the urine is very important: the specific gravity, quantity, urea percentage, presence of albumin, etc., must be taken into consideration. But it is clear that the clinical state of the patient is not a sufficiently accurate guide to the functional capacity of his kidneys. Some form of more direct investigation is required.

The tests elaborated and used during the last twenty years for the estimation of the functional capacity of the kidneys are very numerous. I propose to confine myself to the consideration of those tests which have been used in cases of enlarged prostate.

The Indigo Carmine Test. 20 c.c.m. of a 0.4 per cent. solution of indigo carmine is injected intramuscularly. The dye should appear in the urine in five to ten minutes and the greatest concentration should be reached in about thirty to forty minutes. Thomas relies largely on this test. He compares the quantity of indigo carmine excreted during the first hour with that excreted during the third hour. He regards this index of the greatest value. I use the indigo carmine as a routine in

ordinary cystoscopic work and have also employed it extensively in cases of enlarged prostate, but it has been abandoned for reasons I will give later.

The Phenol-sulphone-phthalein Test (Rowtree and Geraghty).—6 mg. of the dye in solution of 1 c.cm. is injected intramuscularly and the urine collected by catheter. The urine is alkalinized by the addition of a solution of sodium hydrate (25 per cent.) and the time of appearance of a pink tinge is noted. This should appear in about five minutes; 50 per cent. of the dye injected should be excreted in the first hour.

Young relies largely on this test. He says if the time of appearance of the dye is over fifteen minutes, and the amount excreted during the first hour is less than 30 per cent., preliminary treatment is necessary before prostatectomy can be safely done. Bentley Squire and Victor C. Myers believe the test to be reliable when proper precautions are taken to secure an accurate collection of urine by the catheter, but in another paper Bentley Squire says occasionally a patient who has responded in an adequate degree to the phenol-red test, and would appear to be a suitable case for prostatectomy, has, after operation, developed fatal acute suppression of urine.

This test is easy to carry out with a Duboseq colorimeter, and can be done in the ward. At one time I used it extensively, and thought that it would solve many difficulties. But there are very many fallacies. In the first place the presence of even a small quantity of blood renders the test useless. The presence of pus in any but minute quantities is a great handicap. When the urine is high-coloured it is not infrequently extremely difficult to match the urine under test with the standard solution. Another great drawback occurs in cases where a preliminary cystotomy has been done. It is here almost impossible to be absolutely certain of collecting every drop of urine secreted during the first hour. It is easy enough in those cases where a small catheter has been sutured into the bladder, but when a drain of any size has been used on account of a severe cystitis or haemorrhage then the test is unreliable. This difficulty in collecting all the urine after preliminary cystotomy has led us to abandon the indigo-carmin test and the phenol-sulphone-phthalein test.

Ambard's Constant.—This method of comparing the quantity of urea in the urine with the quantity in the blood stream we owe to Ambard.

An extremely complicated method, possessing the drawback, from our point of view, of requiring the accurate collection of all the urine during one hour. This renders this test unapplicable to many cases in which a preliminary cystotomy has been done. We have not employed it.

Urea Concentration in the Blood.

This is the method of estimating renal function upon which we are now placing most reliance. I have had the good fortune to be associated in this work with Dr. William MacAdam, Lecturer in Pathology in the University of Leeds. Dr. MacAdam has carried out the blood examinations in all my cases, and I am deeply indebted to him. He will publish at a later date, and in full, the results of his investigations on the subject of impaired renal function in enlargement of the prostate and other affections of the urinary tract. I hope to be able to prove to you that this method of investigation forms a reliable guide to the condition of the kidneys, and enables the surgeon to select with success those cases suitable for prostatectomy.

The normal concentration of urea nitrogen in the blood varies in individuals. Hammett states that the urea nitrogen varies from 9.7 to 25.1 mg. per 100 c.cm., and that the average is 17.1 mg. per 100 c.cm. Dr. MacAdam, as a result of very numerous tests, regards the upper limit of variability in the normal individual as between 15 and 25 mg. per 100 c.cm.

Observations on the urea concentration in the blood in cases of enlargement of the prostate have been made by various observers.

Bentley Squire and Myers regard the normal blood content of urea nitrogen as 12.15 mg. per 100 c.cm. They think that figures over 20 mg. per 100 c.cm. in patients on the restricted protein diet of hospital suggest impaired renal function. They estimated the blood urea nitrogen in 53 cases of enlargement of the prostate. Of these 53 cases 39 recovered and 14 died. In the 39 cases of recovery the blood urea nitrogen averaged 19.6 mg. per 100 c.cm. In the 14 fatal cases the average blood urea nitrogen was 24.4 mg. per 100 c.cm. In 3 cases in which operation was contraindicated, all of which died—2 from

uraemia and 1 from diabetic coma—the examination of the blood revealed:

Case 1	Blood urea, 24 mg. per 100 c.cm.
Case 2	33 " "
Case 3 (first observation)	87 " "
(second observation)	104 " "

They conclude that the blood urea test is the most valuable pre-operative prognostic test; that cases showing urea nitrogen figures under 20 mg. per 100 c.cm. are good operative risks so far as the kidneys are concerned. When the figures are between 20 and 30, particularly between 25 and 30, the patient should receive a preliminary treatment. When the urea nitrogen figures are over 30 the operative prognosis is bad.

As part of an elaborate and most instructive investigation on the value of Ambard's constant, Kospiro Nakagawa estimated the blood urea in 12 cases of enlarged prostate in which prostatectomy was performed by Mr. Thomson Walker. The average of 11 cases successfully operated upon was 33.2, while the figure in the one fatal case was 54.2.

Two-stage Operation: Preliminary Cystotomy.

We have used this test principally in those cases where a preliminary cystotomy has been done after consideration of the figures. I am able to give the extreme value of the two-stage operation in cases where there is any impairment of renal function. I have performed the two-stage operation in these cases for many years, particularly in hospital, and I am able to give the blood urea figures in those cases in which it was done during the last year.

The advantages of the two-stage operation are many. The preliminary cystotomy is done under local anaesthesia and the time of the second operation under general anaesthesia is much shortened. During the first stage any calculi can be removed; cystitis can be controlled by drainage and treatment of the bladder; the back pressure on the kidneys is relieved, and the patient is able to get sleep. The general condition of the poisoned and uraemic patient usually changes very materially after cystotomy. The appetite improves, the tongue cleans, thirst and headache disappear, and the patient is in an infinitely better position to stand the removal of the prostate.

According to Lillenthal the relief to renal back pressure is indicated by the fact that the ureter orifices, found during the preliminary cystotomy to be patent and dilated, after a period of drainage may be found contracted. I have noticed this in several cases. There can be no doubt that the risk of a post-operative ascending renal infection is much lessened when contraction of the ureter orifices occurs.

The advantages of the two-stage operation in suitable cases have been pointed out by numerous writers, notably Kummel, Wiener, Carlier, Lillenthal, etc., and it has been widely practised. Wiener advocates the two-stage operation as a routine operation in all cases of enlargement of the prostate. He considers it is impossible to determine beforehand which cases are good operative risks, and the possible benefits of a period of drainage of the bladder should be extended to every patient.

There are some dangers in preliminary cystotomy. Peacock has found a rapid fall in blood pressure with a period of diminished reaction of urine and the appearance of albumin and casts in the urine, and Pilcher has also drawn attention to the period of renal depression. But these changes may occur after any method of emptying the bladder, particularly if it is completely emptied at one stage. There are other disadvantages. Freyer is opposed to the method for the reason, as he says, that it delays the radical operation and renders it more difficult to enucleate the tumour owing to the induration of the suprapubic wound. These are certainly disadvantages, and it is not necessary to adopt this two-stage operation in the majority of patients, particularly those above the hospital class. But there can be no doubt that many more cases can be safely operated upon by the two-stage method, and that in cases with marked impairment of renal function and with gross infection of the bladder and kidneys, it is infinitely to be preferred to the operation in one stage.

The figures presented in the following cases are the result of Dr. MacAdam's investigations. In every case duplicate observations have been made and in most cases the observer was entirely ignorant of the clinical state of the patient at the time of the first examination. In almost all these cases McLean's urea elimination test was also carried out. Dr. MacAdam will give his findings at a later date, but as this test requires the collection of all the urine passed during a given period it, like the indigo-

carminic and phenol-sulphone-plthalein tests, is not suitable for those cases where a preliminary cystotomy has been done.

Uninfected Cases.

Case 1.—G. H. S., aged 59. This patient was an example of the class of case referred to where the symptoms are very slight, the patient gradually progressing towards a state of uraemia almost without knowledge of serious bladder difficulty. When first seen he was extremely ill, with a distended bladder, vomiting, a dry tongue, headache, and thirst. He was obviously on the borderline of uraemia.

- February 10th, 1920.—Suprapubic cystotomy under local anaesthetic. Urine sterile.
- February 12th.—Blood urea nitrogen, 39 mg. per 100 c.cm.
- February 22nd.—Blood urea nitrogen, 19.6 mg. per 100 c.cm.
- February 24th.—Prostatectomy.

Coincident with the fall in the blood urea his general condition improved markedly and prostatectomy was successfully performed on February 24th, 1920. He remains well and has no symptoms of impaired renal function.

Case 2.—W. A., aged 56. This patient was in a very similar condition to the first case. He had been troubled with irritability for some time and the bladder had gradually become greatly distended. He was in great pain, vomiting, dry tongue, headache, etc. Urine free from pus cells.

- February 3rd, 1920.—Blood urea, 137 mg. per 100 c.cm. Cystotomy under local anaesthesia.
- February 12th.—Blood urea, 60 mg. per 100 c.cm.
- February 24th.—Blood urea, 50 mg. per 100 c.cm.
- March 2nd.—Blood urea, 28 mg. per 100 c.cm.
- March 4th.—Prostatectomy.
- March 19th.—Blood urea, 16.8 mg. per 100 c.cm.

In this case there was a remarkable diminution in the blood urea after cystotomy coincident with as remarkable a change in his general condition. Prostatectomy was successfully performed. It may be noted that the blood urea diminished after the prostate was removed.

Case 3.—W. S., aged 65, was suffering from advanced organic disease of the heart, with oedema, shortness of breath, etc. The bladder was distended, he was in great pain, vomiting, dry tongue, etc. The urine was free from pus. Catheterization was very painful and difficult. A tied-in catheter was constantly coming out and suprapubic drainage was eventually established.

- September 17th, 1920.—Blood urea, 72 mg. per 100 c.cm.
- September 23rd.—Cystotomy.
- October 7th.—Blood urea, 22.4 mg. per 100 c.cm.

In this case the patient was immensely relieved by cystotomy, and a marked fall in blood urea concentration occurred. Prostatectomy was contraindicated by the general condition of the patient. A permanent suprapubic drainage apparatus was fitted.

No other uninfected cases during last year were submitted to the two-stage operation.

Infected Cases.

Case 4.—J. G., aged 79, admitted with retention. Temperature 100, pulse rising to 130, great pain; bladder very badly infected.

- March 24th, 1920.—Urine contained pus and blood. Urea, 1 per cent. Blood urea, 72 mg. per 100 c.cm.
- March 25th.—Cystotomy.
- March 31st.—Blood urea, 14 mg. per 100 c.cm.
- April 6th.—Blood urea, 11.2 mg. per 100 c.cm.
- April 25th.—Prostatectomy.
- June 9th.—Blood urea, 14 mg. per 100 c.cm.

This patient made a complete but somewhat slow recovery, complete cicatrization of the wound being delayed.

Case 5.—W. G., aged 69, had suffered for some years from frequency of micturition. Retention had occurred. Catheterization was very difficult, and the bladder had been tapped. Urine had leaked through the puncture. Urine contained a quantity of pus and was offensive.

- June 30th, 1920.—Blood urea, 35.5 mg. per 100 c.cm. Cystotomy.
- July 9th.—Blood urea, 28.0 mg. per 100 c.cm.
- July 19th.—Blood urea, 25.1 mg. per 100 c.cm.
- July 23rd.—Prostatectomy.

The patient made a perfectly satisfactory recovery.

Case 6.—S. C., aged 57, had some urinary difficulty for more than a year. Ten months ago he catheterized himself, and ever since the urine has been turbid and contained a deposit. He has agonizing pain on micturition. Residual urine, 6 oz.; urine containing blood and pus, and is offensive. Temperature 102; dry tongue; tenderness over bladder; kidneys tender.

- July 21st, 1920.—Blood urea, 32.8 mg. per 100 c.cm.
- July 22nd.—Cystotomy.
- July 24th.—Blood urea, 28 mg. per 100 c.cm.
- August 26th.—Prostatectomy.

The patient made a satisfactory recovery.

Case 7.—H. W., aged 56, admitted with cystitis, distended bladder, dry tongue, no appetite, great frequency. Urine contained a quantity of pus. Temperature 100.

- April 29th, 1920.—Blood urea, 45 mg. per 100 c.cm. Cystotomy.
- May 13th.—Blood urea, 27.4 mg. per 100 c.cm.
- May 17th.—Prostatectomy.

The patient made a rapid and satisfactory recovery.

The following is an example of a grossly infected case without impaired renal function.

Case 8.—G. S. B., aged 63, had suffered from serious symptoms for a long time. Had been catheterized. Bladder badly infected. Urine contained large quantity of pus and was offensive. Patient in great pain but tongue not dry.

- April 18th, 1920.—Blood urea, 15.8 mg. per 100 c.cm. Cystotomy.
- April 23rd.—Prostatectomy.

Rapid recovery.

The next case is an example of the result of prostatectomy in a patient where the blood urea remained high after cystotomy.

Case 9.—J. B., aged 74, had enlarged prostate for thirteen years. Catheterized himself for ten years. Severe pain and haematuria after making a false passage. Bladder distended. Complete retention. Patient very ill, dry tongue, etc. Temperature 103.

- May 2nd, 1920.—Cystotomy.
- May 3rd.—Blood urea, 45 mg. per 100 c.cm.
- May 17th.—Blood urea, 47 mg. per 100 c.cm.
- May 25th.—Blood urea, 47 mg. per 100 c.cm.

Owing to continued enlargement from the prostate, prostatectomy was performed May 25th, 1920, although the blood urea figures remained high. The patient died within twenty-four hours.

Post-mortem examination revealed prostatic tissue still remaining; the kidneys were markedly granular, with narrowing of the cortex.

The next two cases are examples of badly infected patients with impaired renal function; prostatectomy not performed.

Case 10.—J. A., aged 74, had symptoms for about a year. Had been catheterized frequently. Bladder grossly infected. Catheterization very difficult and painful. Patient rapidly getting worse; vomiting; dry tongue, etc.

- May 24th, 1920.—Blood urea, 43.0 mg. per 100 c.cm. Cystotomy.
- June 7th.—Blood urea, 33.6 mg. per 100 c.cm.

The patient's general condition was much improved but the blood urea figures remained high; prostatectomy discussed but rejected by patient and relatives. Permanent suprapubic apparatus fitted.

Case 11.—F. W. D., aged 60, admitted with retention. Urine 1005, alkaline, large quantity of blood.

- May 31st, 1920.—Blood urea: Finding really owing to technical error. Cystotomy.
- June 7th.—Blood urea, 173 mg. per 100 c.cm.

The patient died uraemic on June 8th, 1920.

Post-mortem examination revealed thickened capsule of kidneys, stripping with difficulty; cortex narrowed and not well differentiated. Renal pelvis on both sides showed marked thickening with considerable evidence of recent inflammation of the mucosa.

Malignant Disease of Prostate.

Case 12.—J. P., aged 65. History of frequency and some haemorrhage. Quantity of pus in urine.

- July 12th, 1920.—Blood urea, 42 mg. per 100 c.cm.
- July 15th.—Cystotomy.
- July 21st.—Blood urea, 33 mg. per 100 c.cm.
- July 26th.—Blood urea, 25 mg. per 100 c.cm.
- August 25th.—Prostatectomy.

Very hard prostate removed with rupture of the capsule and an adenocarcinoma. The urea with rapidly recurrence in the bed of the prostate, the suprapubic apparatus failed to close, and a permanent suprapubic apparatus was fitted.

Case 13.—R. W., aged 69. Prostatic enlargement, lack of

- July 12th, 1920.—Blood urea, 100 mg. per 100 c.cm. Cystotomy.
- Obvious prostatic enlargement. No pus in urine.
- July 25th.—Blood urea, 100 mg. per 100 c.cm.

Permanent suprapubic drainage apparatus fitted.

Case 14.—E. J. B., aged 69. History of months' history. Admitted with retention. Patient very ill, dry tongue, occasional vomiting.

- July 14th, 1920.—Blood urea, 45 mg. per 100 c.cm.
- July 15th.—Cystotomy.
- July 20th.—Blood urea, 45 mg. per 100 c.cm.
- August 17th.—Blood urea, 45 mg. per 100 c.cm.

The patient died on August 26th, 1920.

Post-mortem examination revealed a medullary prostate with involvement of the bladder wall. Both kidneys showed extreme pyelonephritis, with the tubules crossed scattered through out the medulla and cortex.

Case 15.—W. H., aged 70. Hard fixed and nodular prostate. Urine loaded with pus.

- April 31st, 1920.—Blood urea, 45 mg. per 100 c.cm.
- April 17th.—Blood urea, 40 mg. per 100 c.cm.

Retention relieved by catheter. The patient left hospital April 30th, 1920.

Cases 16, 17, 18. Blood urea estimations were made in three other cases of enlarged prostate. The figures were:

W. E., aged 59. Blood urea, 12 mg. per 100 c.c.m.
H. H., aged 65. Blood urea, 15.4 mg. per 100 c.c.m.
J. L. H., aged 67. Blood urea, 16.8 mg. per 100 c.c.m.

Prostatectomy was successfully performed in these cases.

COMMENTARY ON THE CASES.

The following conclusions can be drawn from the examination of the figures in these cases:

1. The blood urea concentration corresponds very closely with the clinical symptoms. In those cases (Nos. 1 and 2) where the patient was becoming uraemic the blood urea concentration was high.
2. Impaired renal function occurs in patients who have no infection of the urinary tract, the renal impairment being due entirely to back pressure. (Cases 1 and 2.)
3. Severe infection of the urinary tract (? confined to bladder) may be present without impaired renal function. (Case 8.)
4. The majority of cases of serious infection had impaired renal function.
5. A decided fall in blood urea concentration occurs after cystotomy, in the majority of cases the blood urea figures falling practically to normal.
6. The seriousness of those cases in which the blood urea figures remained high after cystotomy. (Cases 9, 11, and 14.)

I think it will be agreed that many of these cases were saved by preliminary cystotomy; of course, this was combined with general treatment on the ordinary lines—free administration of fluids, purgation, light diet, urinary antiseptics, diuretics, etc. In some cases cardiac and pulmonary complications required attention. In this series there was no case of glycosuria or tabes or other nervous disease. The cystotomy was done under local anaesthesia, and the bladder emptied slowly. In some cases of extreme distension a catheter has been passed and the bladder gradually emptied during twenty-four hours, the cystotomy being then performed. This avoids the risk of reflex suppression, haemorrhage and shock which may follow rapid and complete emptying of a very distended bladder either by the catheter or by suprapubic cystotomy. In one or two cases painful spasm of the bladder has occurred when it has been evacuated too quickly through the suprapubic wound.

Certain surgeons, notably Young, believe that suprapubic drainage is not often required and that regular catheterization is generally sufficient in infected cases and cases with impaired renal function. On the other hand, it is well known that the patient with impairment of renal function is apt to succumb rapidly after catheterization. I believe that when the blood urea figures are high cystotomy is an essential, and much to be preferred to regular catheterization or to the use of the tied-in catheter. In badly infected cases there is no comparison in the efficiency of the two methods of draining the bladder: cystotomy with antiseptic instillation is infinitely preferable to catheterization. An objection to the performance of a preliminary cystotomy is that one may find a high blood urea figure persisting after the cystotomy and contra-indicating prostatectomy. The patient must then be fitted with a permanent suprapubic drainage apparatus. It is conceivable that he might have preferred to end his days getting such relief as is possible from the catheter. This point must be explained to the intelligent patient.

INFECTION OF THE URINARY TRACT.

This may be present with or without any impaired renal function. We have at present no means of safely ascertaining in these cases whether an infection is limited to the bladder or whether it has involved one or both kidneys. Bilateral ureteral catheterization is not to be thought of in such cases as we are considering. Nor have we any means of ascertaining in any given case whether impaired renal function is due to the effects of back pressure alone or to back pressure and pyelonephritis. No doubt the kidneys may be infected without their function being impaired. In such cases the blood urea figures will remain normal. It is conceivable also that one kidney may be grossly infected, indeed partially destroyed, and the other kidney carrying out the work of excretion in such a way that no blood urea concentration is found. The clinical

signs are few and not reliable. If a patient with fever, rigors, pyuria, a dry tongue, vomiting, etc., has tenderness and enlargement of the kidneys there is no difficulty; but it is otherwise when the clinical signs are very slight. The matter is of great importance from the fact that a patient without definite clinical signs of renal infection and without any evidence of impaired renal function may after prostatectomy succumb to an acute pyelonephritis.

I have only been able to trace one case during the last year in which fatal pyelonephritis followed prostatectomy, where a preliminary blood urea test showed no impairment of renal function. My colleague, Mr. Walter Thompson, has kindly allowed me to refer to the case.

The patient, a man aged 58, was admitted with an enlarged prostate causing extreme frequency of micturition and sometimes nocturnal incontinence. The urine was 1020 specific gravity, and contained a trace of albumin. The blood urea test showed 19.6 mg. per 100 c.c.m. on October 25th, 1920. Prostatectomy was performed on November 4th, and the patient died on November 11th, 1920. *Post-mortem* examination showed an intense inflammation of the bladder with pyelitis and multiple abscesses in both kidneys.

Control of Infection.

A great deal can be done in infected cases to control the infection of the bladder or bladder and kidneys before prostatectomy is performed. The ordinary routine treatment of the infected bladder may be carried out, namely, regular catheterization, the administration of urinary antiseptics by the mouth, washing out the bladder once or twice daily with an antiseptic through the catheter, etc. Or a preliminary cystotomy may be done, and lavage of the bladder performed through a catheter or through the drainage tube. These methods are in many cases all that is necessary, but in all probability improvement is due mainly to the emptying of the bladder rather than to the lavage. For some years I have been treating the infected bladder on the lines laid down by Carrel for the treatment of infected wounds. In every case in which a cystotomy is done a drainage tube with two Carrel tubes attached is passed into the bladder; through these Carrel tubes two ounces of an antiseptic solution is injected into the bladder every two hours. The Carrel tubes have holes at intervals and the solution must come into contact with practically every part of the bladder mucosa. The patient is kept dry by a Hamilton Irving apparatus, a most satisfactory appliance in the hands of a capable nurse. The antiseptic I usually employ is the ordinary eusol solution, sometimes diluted to half-strength; Dakin's solution is too irritating; flavine I have thought comparatively ineffective. We have endeavoured to estimate the extent to which the infection is controlled by using an antiseptic in this way by various methods: by counting the number of organisms in a film taken from the suprapubic wound; by estimating the amount of pus in the urine over a given period. These methods have proved quite unreliable and very difficult to carry out. One can only judge by clinical results. It can be said with certainty that the amount of pus materially diminishes, that offensiveness of the urine quickly disappears, and that such complications as cellulitis of the cavum Retzii and phosphatic deposit in the suprapubic wound do not occur. I have said before that we have no means of telling whether the kidneys are infected as well as the bladder; neither have we any means of determining the effect of treatment on these lines on the infection of the kidneys. One can only give one's impressions gathered from ordinary clinical observation. I am convinced that drainage of the bladder with regular instillation of an antiseptic into the bladder has a very marked effect on infection of the kidneys.

There is another advantage in the regular instillation of an antiseptic into the bladder on the Carrel principle. Cases of acute infection of the bladder following the establishment of suprapubic drainage in cases of fractured spine, gunshot wounds of the spine, etc., are not unknown. In such cases the infection occurs via the drainage tube; it can be prevented by the instillation of an antiseptic. It is probable that if preliminary cystotomy were carried out in those cases of retention with impaired renal function but as yet uninfected, infection via the drainage tube would readily occur. We know it occurs very readily by a catheter, and I do not think I would venture to drain such

a case without taking the precautions to prevent infection which are available by regular instillation of an antiseptic. One may say with truth that, as a catheterized bladder will be an infected bladder, so also will a drained bladder.

Infection after Prostatectomy.

Some degree of inflammation of the bladder probably occurs in every case after suprapubic prostatectomy, generally because the bladder was already infected. In the ordinary case the infective process causes no anxiety, it does not lengthen the period of convalescence, and it does not persist after the wound is healed. But septic changes occurring in the bed of the prostate may have serious consequences; sometimes a more or less prolonged suppuration occurs; epididymitis is not uncommon; septic thrombosis of the prostatic veins leads to pelvic phlebitis with oedema of the legs, or even pulmonary embolism. Further, the infection may spread to the kidneys and cause pyelitis, pyelonephritis, pyonephrosis, or multiple abscess formation in the substance of the kidney. It is probable that in the majority of cases in which these serious complications arise the kidneys were infected before operation; but, as I have said before, we have no means of determining this with safety. These septic complications are particularly likely to arise in cases with dilated ureter orifices and impaired renal function.

In order to minimize the risk of these complications occurring I believe that antiseptic instillations should be continued after the prostate has been removed. The drainage tube, not too large, with two attached Carrel tubes, is used for the first few days; then the drainage tube being discarded, one Carrel tube is inserted into the bladder; later, if thought advisable, a double-channelled catheter is passed and the instillations continued through one channel. Instillation is deferred for the first twelve hours after operation to avoid the risk of disturbing clot and exciting haemorrhage; instillation is much less likely to induce a secondary haemorrhage than is bladder lavage. True secondary haemorrhage is due to septic changes in the bed of the prostate, and these changes are much less likely to occur when regular antiseptic instillation is practised.

It is important not to be in too great a hurry to obtain healing of the suprapubic wound after prostatectomy, in cases of serious infection of the bladder. I was asked lately to see a case where the wound had healed and the patient was passing urine ten days after prostatectomy, but pyuria persisted and increased, and the patient died from septic pyelonephritis.

USE OF BLOOD UREA ESTIMATION IN DETERMINING THE NEED FOR PROSTATECTOMY.

Some degree of enlargement of the prostate is extremely common. Many elderly men suffer from frequency of micturition, and examination shows a degree of enlargement, with some residual urine. A large proportion of these men never experience any really serious trouble with the prostate. If they are not interfered with and not infected, they end their days comfortably, despite the disability. Prostatectomy is here unnecessary and meddling. They may even have an attack of retention, necessitating the use of the catheter for a few days. If not infected, recovery may ensue and no active treatment be required. But they require watching very carefully, and here the value of the blood urea test is most noticeable. If the proportion of urea in the blood shows a tendency to rise steadily in a patient known to have an enlarged prostate, even if his symptoms are not aggressive and there is no infection, haemorrhage, or distension of the bladder, the desirability of prostatectomy must be considered.

CONCLUSIONS.

1. Blood urea estimation is a reliable guide to the functional capacity of the kidneys.
2. Its estimation should be carried out in every case of enlarged prostate before operation.
3. Blood urea figures over 25 point to the desirability of a period of preliminary treatment, with drainage of the bladder either by catheter or through a cystotomy wound.
4. If the tied-in catheter is used further blood urea estimations will show whether improvement is taking place.
5. If not, a cystotomy should be done and further estimations carried out.

6. When the blood urea figures fall to under 30 prostatectomy may be done, the general condition of the patient being in other respects satisfactory.

7. In preliminary cystotomy and regular antiseptic instillation we have a method of dealing with cases of impaired renal function, whether due to back pressure only or to back pressure and renal infection. We can estimate the impairment in renal function by estimating the blood urea; we can only estimate the improvement in the infection of the kidneys by ordinary clinical observation. If the blood urea figures are normal, with a badly infected bladder, it is probable that one may assume that the kidneys are not yet infected.

DISEASES OF INFANTS DUE TO PROLONGED FEEDING WITH EXCESS OF CARBOHYDRATES.

By C. E. BLOCH, M.D.,

PROFESSOR OF PEDIATRICS IN THE UNIVERSITY OF COPENHAGEN.

CHILDREN'S as well as adults' food must consist of a suitable mixture of protein, carbohydrate, and fat, besides water, salts, and some indefinite specific substance, though of course it is known that adults can live for a considerable time on a diet mainly composed of two of these substances. Here in Denmark Hindhede has shown that it is possible to exist on a diet comparatively free from protein, so long as it contains plenty of carbohydrate and fat; and the Eskimos' mode of living, and our experiences in the treatment of diabetes, show that man can live quite well on a diet chiefly consisting of protein and fat. On the other hand, it is beyond question that in the long run man suffers from such a one-sided diet, and if left to himself he will always try to vary his food.

As regards infants, we know that they too can thrive for some time on a diet poor in protein. Some years ago Biedert's cream treatment was much in use for infants; this was, however, abandoned, not because cream is particularly poor in protein and thus has a detrimental effect, but because the children, owing to the excess of fat, suffered from acute or chronic dyspepsia, leading occasionally to atrophy.

Feeding with Finkelstein's albumin-milk, which, when it was first tried, consisted almost exclusively of protein and fat, showed that infants are very sensitive to an insufficient supply of carbohydrates. Even a short course of this diet may lead to collapse. Carbohydrates are essential for infants, and they will digest not only sugar, but small quantities of starch also.

Formerly all starchy food was considered most harmful to infants, and diseases such as rickets, anaemia, and scurvy were ascribed to it. All the old specialists in diseases of children, therefore, prohibited the use of starch in the diet of children under 12 months. We now know that this is not so, and we give starchy food to infants suffering from a number of complaints, with great benefit. Buttermilk, malt and skimmed milk, contain, in addition to protein, large quantities of carbohydrates, consisting of sugar and starch, and this diet apparently often suits the infants admirably. It is, however, destitute of fat, and it is for this reason, as well as on account of its richness in carbohydrates, that it improves the condition of infants suffering from chronic dyspepsia and infantile atrophy.

The question whether infants can thrive without fat is at present of particular interest in Germany and Austria-Hungary, where there is a considerable shortage of fats. Pirquet has investigated this question, and has recently published his results. He changes abruptly from the ordinary diet to one in which fat is lacking, feeding the children on centrifuged milk to which is added plenty of cane sugar. In spite of the sudden change of diet he can find no change in the children's condition; they thrive and develop as before. Pirquet comes to the conclusion, therefore, that there is no apparent fat minimum for man, so long as the absence of fat is made up for by double the quantity of carbohydrate. That this conclusion is wrong the following considerations seem to prove.

As regards adults, we have no record of a diet consisting solely or chiefly of only one of these substances. No man will, of his own accord, live on protein alone, fat alone, or carbohydrate alone. The only instance of such a diet

being in use in Denmark is under the penal laws, when imprisonment with bread and water is resorted to. This means that the prisoner is fed on a diet chiefly consisting of carbohydrate, with only a small addition of vegetable protein. Six periods of five days, however, is the longest time permitted for this punishment, and even then it is interrupted every fifth day, when the prisoner is given ordinary food. There is no reason to think that any permanent harm ensues to the prisoners from this treatment, so long as they are otherwise in good condition, but they are said to be in a most miserable state when the punishment is over.

With regard to children, a diet of this description is, however, not at all uncommon, particularly for small children who are entirely dependent on what other people give them. Infants are often kept for weeks, even for months, on a diet consisting of carbohydrate, with a small amount of cereal proteins, which greatly resembles the prisoner's diet of "bread and water." This is the case when older children are put on the so-called "constipating diet," consisting mainly of barley water, oatmeal gruel, biscuits, rusks, bread, and occasionally bilberry juice, in addition to a kind of pudding made of rice boiled in water. In the case of infants, they are kept on a barley water and oatmeal diet for a long period, and sometimes the mothers feed their babies mainly on biscuit food. Feeding entirely on patent foods is very nearly the same thing, as most of these productions are in reality only refined biscuit foods.

If this food is merely given for a couple of days, or as an addition to the natural diet, or, again, with any of the ordinary milky diets, it is excellent. It is only when carbohydrate forms the main part of the food, and is continued for a long time, that it will be the cause of various forms of sickness.

The diseases caused in this way correspond only partially with the conditions described by the older specialists in children's diseases as due to a starchy diet. Only during the last few years have the conditions which occur when the child is fed on a diet excessively rich in carbohydrate been elucidated. The German doctor Czerny and his followers (Keller, Gregor, and Rietschel) gave the first and best descriptions of them; "Mehlnährschaden" he calls them. These disorders were apparently seldom met with in Germany in the past, whereas they seem to be of rather frequent occurrence in Denmark, judging from our experiences at the State hospital. As by degrees they become better recognized these complaints will be seen mostly in the form of mild attacks, seldom in their more pronounced forms.

The diseases arising from prolonged feeding with carbohydrate, with the relative exclusion of animal fats and proteins, vary apparently according to the child's age and original state of health and to the length of time during which the child was subject to the harmful diet. It has, however, not yet been possible to differentiate various forms of the disease, corresponding with the various carbohydrates. All kinds of starch and sugar seem equally injurious when given alone and for a prolonged period.

The following cases show the changes in the conditions of new-born and delicate babies after feeding them on carbohydrates alone for a long time:

Carl C., born June 21st, 1913; entered hospital August 30th, 1913; died August 31st, 1913. The child was a twin, of healthy parents; weight when born 2 kg. The first few days he was breast-fed, but when it was discovered that the mother had not sufficient milk, barley water was added to the diet. The child soon stopped suckling, and had, therefore, barley water only. He apparently thrived quite well, but about three weeks before admission to hospital he started getting weak. He did not drink much and the bowels acted more frequently, with loose evacuations. Recently he had been so weak that it was decided to bring him to the hospital. He was a most miserable little weakling. He lay perfectly still, with the arms bent and the legs drawn up. The abdomen was small, the skin dry and scaly, with extensive intertrigo on the buttocks. The fontanelle was sunken and the bones of the skull thin. The heart was weak, the pulse imperceptible, temperature 33.7° C. Both eyes showed xerophthalmia. Weight 1,640 grams.

In spite of various stimulants, such as hot baths and hot-water bottles, the temperature could not be raised above 34.3° C. He had constant signs of collapse, and died about twenty-four hours after he had entered hospital. The *post-mortem* examination showed bronchitis and isolated ecchymoses of the organs; otherwise the clinical examination was confirmed.

The conditions brought about by a diet consisting chiefly of carbohydrate resemble those due to chronic inanition. The store of fat and protein is drawn upon, and being weak from birth the child loses weight rapidly immediately suckling ceases. It gradually gains the appearance which is usually termed atrophic, but I prefer the term atrophica amylogenetica to distinguish it from the true atrophy of children, from which it differs both in origin and appearance. The treatment of the two types is also to some extent different.

If the child is a few months old, and particularly when it is strong, the excessive carbohydrate diet seems to cause quite different symptoms. If the child has been given milk from time to time, then the changes may be quite characteristic, as will be seen from the following case:

Anna J., born January 17th, 1914, entered hospital April 17th, 1914, discharged June 9th, 1914. The child had never been nursed at the breast. She was a strong baby when born, and for the first month and a half had nothing but oatmeal gruel. Later a little milk was added to the gruel, generally one part of milk to two parts of gruel. Latterly she was given biscuit diet daily, and from time to time dilute milk (half milk and half water). The child seemed to develop excellently on this diet, and increased rapidly in weight. Latterly the mother thought the child was getting too fat, and noticed that she was getting rather fretful. The bowels always acted normally.

The child looked very fat, but the subcutaneous tissues were spongy and the eyes were half closed on account of oedema which was general. The abdomen and lower extremities were very tense from the oedema. There was no ascites. The child was pale and limp. There were fissures behind the ears and intertrigo on the buttocks, otherwise the skin was normal. Weight, 5,070 grams; temperature, 36.3° C. Urine normal.

A diet of ordinary sterile milk and barley water as a basis gradually caused the oedema to disappear, and the tissues regained their normal texture. The weight at first decreased to 4,800 grams, but later the child did well and weighed 5,300 grams when discharged, although she was a good deal behind in development.

A spongy and hydraemic condition of the tissues develops, which is a direct consequence of the carbohydrate diet. If this is even partly changed the oedema disappears. In well-marked cases the children have an appearance similar to that of Bright's disease, but the urine never contains albumin or kidney elements. In the primary stage of this disease the tissue is only puffy and spongy, and this stage is the one more frequently met with.

The authors who first described this form of the disease called it hydraemic atrophy. This is, however, a misleading term, as these children do not look atrophic. It would be more to the point to call it dystrophy, as the growth is distinctly abnormal. Furthermore, the hydraemic condition is not always very marked, particularly in early cases; and the tissues may even, in a few exceptional and very serious cases, assume quite a different character.

Lydia A., born April 30th, 1915; entered hospital September 23rd, 1915; died October 2nd, 1915. The child came of a healthy family, and she was a strong baby when born. For the first month she had nothing but patent food, and the following two and a half months oatmeal gruel and semolina pudding, made with one part of milk to three parts of water; as the child got diarrhoea the mother took to patent food again, which the child had been fed on ever since. The mother declares the child was quite fit and doing well up to a fortnight ago. It then became limp, drank poorly, and the evacuations were loose.

It was a miserable, pale child, evidently suffering a good deal; it cried at the slightest touch, but no hyperaesthetic areas could be found. The child was very exhausted and cold, with bluish hands and feet. The heart was feeble, the pulse imperceptible. The state of nutrition was apparently good (weight, 3,800 grams), but that was due to the subcutaneous tissue becoming sclerotic nearly everywhere. There was no oedema. The child lay nearly always with the head retracted and the arms in the "paw position." There was pronounced hypertonicity of the muscles; the skin was perfectly dry, and its turgor nearly gone; there were occasional papular infiltrations. The conjunctivae were dry and injected, the eye itself dull. The urine showed no albumin or cells.

In spite of stimulants and breast-feeding the child did not recover. The necropsy showed purulent pneumonia, otherwise the clinical features were confirmed.

The plump appearance in this instance was not due to oedema, as in the previous case, but to general sclerotic infiltration of the subcutaneous tissues. This gave the child a peculiar mask-like appearance, and it was still more uncanny on palpation.

Although the child was much behindhand in growth and development, atrophy would hardly be the right word.

The appearance was not atrophic; she had grown to some extent, but the condition of the tissues showed that development had been abnormal. The dystrophic and atrophic forms are identical in their origin, both being due to a diet consisting chiefly of carbohydrates, particularly starch, over a long period. I therefore prefer to call these complaints "dystrophia amylogenetica," in order to distinguish them from other forms.

From my rather large and gradually accumulated experience of these regrettable diseases, it appears that it is the delicate and newly-born infants that are most susceptible to the atrophic form, and the stronger and somewhat older ones that mostly suffer from dystrophy, particularly if from time to time they have had a little milk, or milky foods, in addition to the carbohydrate diet.

The peculiar rigidity and tone of the muscles often observed show that they have become changed. This was first observed and described by Gregor, and more thoroughly later by Czerny and Keller. The pronounced cases show opisthotonos and an elastic resistance of the muscles. This was present in the first and the last of the above quoted cases. It is comparatively easy to straighten out the contracted muscles, but they relapse at once as soon as released. This hypertonicity is a serious prognostic sign, but it disappears easily and quickly if the patient recovers. As far as I have been able to observe, it is not related to infantile tetany, which it somewhat resembles.

Common to all children fed on a carbohydrate diet is their great susceptibility to all infections. These children nearly always have some infection, most often of the mucous membranes or a simple dermatitis. When serious acute infections set in they will as a rule react with an enormous loss of weight, due to the surplus water in the tissues suddenly being excreted.

The prognosis of these cases is always very serious and distinctly unfavourable when the vital parts are degenerated.

The most important point in the treatment of these children is careful nursing and the use of stimulants. Furthermore, their diet must be altered so that they obtain the substances they have been without for so long—that is, protein and fat. The best way of doing this is to give them a wet-nurse. If one is not available they must be fed on a diet the basis of which is sterile milk, diluted according to age. Care must be taken, however, not to give too large quantities at first. In particular, when giving cow's milk it is necessary to be very careful, as by taking more than can be digested the child might get chronic dyspepsia or genuine atrophy.

It is a mistake also suddenly to stop the supply of carbohydrates, and still worse to put these miserable children on a diet of water or tea, from which I have often seen the most disastrous results. When the milk diet is started the children must be given as much carbohydrate as they can digest at their respective ages. The best course to pursue is, naturally, to employ a wet-nurse at the same time, and in the most serious cases this is the only means of saving the child's life.

In these cases the faeces become not only sour and fermented, but foetid and irritating; the skin of the buttocks gets red if the soiled napkin is left in contact with the child's skin only for a short time. If the irritation is repeated many times, the skin will be affected by weeping intertrigo all over the napkin area. It is, however, not only the skin which shows the effect of the irritation of these evacuations. The mucous membranes of the intestines, particularly the large gut, reacts at first with slimy secretion, later with haemorrhage, and with brisk peristalsis. As a consequence the child is restless owing to attacks of colic and frequent foul-smelling evacuations. Gradually there ensues a typical colitis, which in many cases is very serious. I have termed this disease "colitis amylogenetica" because of its association with carbohydrate, particularly starch. It occurs in a mild form in the younger infants; only the older and stronger children show characteristic "colitis amylogenetica," and my experience indicates that it is more frequent amongst children in the country. The reason why it is so frequent must, I think, be sought in the prolonged and ill-advised use of the so-called constipating diet. Another cause of its frequency is no doubt to be found in the disinclination of

many doctors to administer milk and milk preparations to children suffering from diarrhoea, though a milk diet is undoubtedly in most cases the best treatment for chronic infantile diarrhoea. Even in the case of infectious toxic cholera infantum a milk and water diet is much to be preferred to barley or oatmeal water.

I have seen quite a number of children wrongly treated by means of a long-continued constipating diet, and many of them have been in a most miserable condition, particularly when they have been simultaneously loaded with bismuth and silver nitrate, combined with enemata of the latter. I have even seen children become scorbutic under this treatment.

The evacuations may remain watery in spite of the milk diet, which contains only trifling quantities of carbohydrates. It may in these cases be necessary to give the intestines a complete rest, by giving the child for one or, at the most, two days, boiled water only, or weak tea, without milk or sugar, but with saccharine if necessary. On the second or third day milk diet may be started (one part of milk and two parts of water); and at the same time may be given increasing quantities of protein milk. It is not easily fermentable, and therefore is most suitable for the treatment of these cases of chronic colitis. It is made as follows:

To one litre of rich milk is added one teaspoonful of Hansen's liquid rennet. The milk is then placed in a water bath at a temperature of 42° C. to 43° C. for half an hour; it is poured through gauze, when the coagulum is collected and the whey drained off. The casein is now rubbed through a very fine sieve, and this is repeated ten times. The first few times the casein is mixed with half a litre of butter-milk, and later with an equal quantity of water. After mixing, the liquid should pass readily through the sieve. The protein milk is now boiled with continuous stirring and the desired quantity of sugar added (usually 30 grams of castor sugar). After the addition of sugar the milk is quickly cooled with continuous stirring, and then once more passed through the sieve. The prepared protein milk must be kept in a cool place.

Apart from the diet, I administer preparations containing tannin, preferably acorn cocoa in milk. If it does not agree I use albumin tannate, which has the advantage over metallic salts of being non-toxic. It can be safely given in doses of a couple of grams a day for a long time, even to quite young children. In some cases bismuth salts will give better results, the best being bismuth subsalicylate. If, however, the motions are not stained black, the drug may be stopped, as it is having no effect. As bismuth is a poison, it should never be administered for a long period, and it ought to be a fixed rule never to give bismuth, or preparations containing tannin, to a child when on a diet of water or tea. These constipating drugs will only give satisfactory results when taken with milk and milky or other foods.

The oatmeal and barley-water diet will generally be sufficient in cases of ordinary acute dyspepsia, particularly in those frequent cases where the diarrhoea is due to overfeeding with milk and milky foods, causing a pronounced protein decomposition in the intestines. Here it is essential that the barley water should be thin and never sweetened with more than 2 per cent. of cane sugar. Such a diet is meant to be a starvation diet, intended to give the intestines a rest. In the case of an ordinary diarrhoea, the bowels will act normally after a few days of such a constipating diet, and the children may then gradually be given their usual food.

By the term "milk," as used above, is understood good fresh milk which has just been brought to the boil. Raw milk might have just the opposite effect, and this is the reason why children suffering from these intestinal complaints should always be given boiled milk.

At the annual meeting of the Society for the Prevention of Hydrophobia, held at the Farmers' Club on February 1st, Major John Penberthy, ex-president of the Royal College of Veterinary Surgeons, was elected chairman of the committee. The annual report stated that experience of the outbreaks of rabies in this country during the past two years had confirmed the society in its policy of advocating universal muzzling of dogs for a limited period. The futility of attempts to stamp out rabies by muzzling dogs in limited areas has again, it is stated, been demonstrated by recent experience. Mr. F. W. Fletcher, F.C.S., Windmill, Enfield, Middlesex, has been elected honorary secretary in the room of the late Mr. Frank Karslake, one of the founders of the society.

During this treatment the child is often given only arrowroot and water, or barley water.

SAPRAEMIC GLYCOSURIA.*

BY

CHARLES GASKELL HIGGINSON, M.A.LOND.,
M.D.DURHAM.

A NEW truth needs much tenacity of life, for few men like to be disturbed in the opinions that they have been at the pains to form; and I am now venturing to expound once again a true doctrine which, though it was well established twenty-two years ago, has not yet been properly diffused through the medical profession, but has had a narrow escape from oblivion. An illness of my own is the reason why this exposition falls to my lot.

In July, 1909, when I was working in a Berkshire sanatorium, I was suffering so much from a hard carbuncle, four inches in length by three in breadth, almost mesially situated where the occiput joins the neck, that I determined to consult Mr. X., of Harley Street. While waiting for my cab I tested my urine, so as to save the surgeon some trouble. I found that Fehling's solution precipitated copper, indicating that I had glycosuria; and a brother practitioner, concluding that I had diabetes as the foundation for my carbuncle, made to his friends a confident prognosis of my imminent death. My own view was that, in any case, Mr. X. would operate, and that, even if he did not, no harm would be done by consulting him.

As I had no thirst nor hunger, nor emaciation nor polyuria, I doubted whether I had diabetes, and I let my thoughts stray among the exceptional glycosurias of the textbooks. Still, I went to Harley Street thinking that, on the whole, the balance of probability was in favour of diabetes, that I should not live long, and that perhaps, like my grandfather, I ought to be contented with the fifty-one years of life that were already mine. After a swift examination, Mr. X. said: "Don't be surprised or afraid if you get glycosuria with this great carbuncle; you will probably have it." I replied: "Pray do not trouble to prophesy; I have it already." Then Mr. X. uttered, with the utmost confidence, these unexpected words: "And you will lose it." He told me that a fellow-resident of his at St. Thomas's Hospital, now Sir Cuthbert Wallace, had proved that the glycosuria of carbuncle and gangrene was commonly not the cause of these diseases, but that the sapraemia from the carbuncular or gangrenous focus was the cause of the glycosuria, just as phloridzin or other poisons caused glycosuria; and that Mr. Wallace had even gone one step farther, and had found that, while glycosuria would appear in the normal person after eating half a pound of glucose, yet in a person whose carbuncle was not quite sufficiently poisonous to produce glycosuria unassisted, glycosuria would appear on his eating (according to the degree of poisoning) one, two, four or six ounces of glucose. Thus, he jokingly added, there was no excuse for our failing to understand the boast of men who said that they had cured diabetes by amputating a leg! The patient would have been suffering from sapraemic glycosuria generated by a gangrenous focus on the leg, and amputation would have cured the glycosuria by removing its cause. So I endured the cruciform incision, and in three weeks my enemy had sloughed away, and I was free alike from carbuncle and glycosuria.

Six months afterwards I consulted a distinguished physician and told him the facts. He smiled incredulously and at once asked for a specimen of my urine, and he was amazed at finding no sugar. In order to see how normal I was as regards my saturation point for glucose a year after my illness, I found that four hours after I had eaten half a pound of glucose my urine contained $1\frac{1}{2}$ grains of glucose to the ounce, according to both methods, Roberts's and Pavy's; in six hours I found no glucose. (Some days afterwards I tried to eat a pound of glucose, but vomited after 13 ounces.) So I must be considered normal as regards my saturation point, which, as regards alimentary glycosuria, is registrable at eight ounces of glucose. Never since have I had glycosuria, alimentary or sapraemic, nor tried to get it.

History of the Doctrine.

Thirty years ago it was held that "diabetes offers an almost positive bar to any kind of operation" (Treves's

Operative Surgery, i, p. 18, 1891). The present writer, while a student, frequently saw patients suffering from gangrene left to die unhelped by operation because glucose had been found in their urine, and it was through investigation of cases of gangrene complicated by glycosuria that truer views were first reached.

In the *Medico-Chirurgical Transactions*, vol. 75, 1892, is a paper by Mr. W. G. Spencer on amputation in diabetes mellitus. After recording the cases on which he bases his conclusions, Mr. Spencer says:

"Such stress has been laid upon the danger from inflammatory complications in diabetes mellitus that many writers condemn operative procedure without qualification, or at least omit to state the indications for it. Yet there is enough evidence, I believe, to show that by the timely adoption of major amputations life may be prolonged and the amount of sugar excreted reduced to a minimum (the italics are mine) in cases where the attempt to effect this by medicinal treatment, in the presence of a severe inflammatory lesion, has quite failed."

Here we have the definite statement that glycosuria may be reduced to a minimum by the removal of a septic focus. How very near he came to the complete discovery of the true doctrine! Again he says: "To put the conclusions in another form. Diabetic gangrene should be operated upon by following the rules already established for other forms of gangrene." Here we have a direct contradiction of Sir Frederick Treves's statement of the previous year, that "diabetic gangrene of a limb is scarcely within the scope of surgical measures; an amputation in such a condition is almost invariably fatal." Sir Frederick Treves, in view of the articles of Mr. Spencer and Mr. Rickman Godlee, rewrote in subsequent editions his own views in the light of theirs.

In the next volume of the *Medico-Chirurgical Transactions*, vol. 76, 1893, Mr. Rickman Godlee (now Sir Rickman Godlee) wrote an article entitled "On Amputation for Diabetic Gangrene." He writes to much the same effect as Mr. Spencer, and definitely denies the doctrine of 1891:

"In truth the introduction of the antiseptic principle has rendered operations upon diabetics very much less formidable than they used to be when most of the present textbooks on surgery were written. The weakened tissues may be, and often are, able to withstand the mere mechanical injury of an operation, although they cannot endure this as well as the irritation produced by putrefaction. At the same time it must not be forgotten that no amount of antiseptics can do away with the danger of coma or heart failure following an operation, though their wise employment may immensely diminish the chance of sloughing of the flaps."

Here Sir Rickman definitely singles out the successful use of antiseptics as the chief cause of the newly discovered comparative safety of operations on so-called diabetics. The next year, in the *St. Thomas's Hospital Reports*, New Series, vol. 22, 1894, there appeared an article by Sir Cuthbert Wallace on "A Case of Gangrene of Foot with Sugar in the Urine successfully treated by Amputation."

"The amount of sugar," he says, "rose for the first three days after operation—560, 1,360 and 1,400 grains being the respective amounts in twenty-four hours. From this time the quantity fell, except for an occasional rise, continuously until the fifteenth day, when the amount was only 190 grains. Then for three days there was only a trace, when, on the nineteenth day the amount rose to 234 grains, to fall next day to 60 grains. On the succeeding day there was a trace, after which the sugar ceased entirely."

Again: "It happens occasionally that after amputation the sugar disappears or is greatly diminished, and this seems to suggest that it is possible that the gangrene may cause the presence of sugar, possibly through the absorption of septic products." (Italics mine.)

We have often noticed the remark of the textbooks and teachers of to-day that "transient glycosuria may be associated with a carbuncle," which shows that we ought now to be ready for the true theory to fit the observed fact. Formerly the glycosuria used to be considered to be the predisposing cause of the gangrene or the carbuncle associated with it. Here, for the first time, we have the suggestion strongly conveyed that, on the contrary, the sapraemic condition may be the cause of the glycosuria.

In the *Lancet* of December 23rd, 1899, Sir Cuthbert Wallace published another paper on "Gangrene Complicated by Glycosuria." Here we find the whole theory of transient glycosuria elaborated, and based on the observation of typically septic cases of gangrene, carcinoma of rectum, ulcer of rectum, erysipelas, lymphangitis, and carbuncle.

*A paper read at the Medical Institute, Birmingham, before the British Medical Association, on December 16th, 1919. Revised, January 18th, 1921.

The Saturation Point.

There is in normal human blood glucose to the amount of about 1 per 1,000. In diabetes the blood may contain from three to six times as much. The portal vein may in normal life contain 4 per 1,000. This glucose, $C_6H_{12}O_6$, on reaching the liver is arrested there, and stored in the form of glycogen, $C_6H_{10}O_5$, till it is served out to the blood again gradually, in another form, for the needs of bodily heat and work, etc. Normally the liver is not surcharged with glycogen, nor the blood with sugar. That is to say, in Sir Cuthbert Wallace's language, that the saturation point is normally not reached. But when, either because of the liver's insufficiency as a storehouse of glycogen, or because too much glucose is poured into the blood stream, the blood is surcharged with glucose, the saturation point is said to have been reached and passed. Then the blood excretes its surplus glucose into the urine, and glycosuria occurs.

Now the saturation point is by no means constant, and if for any reason it falls, it may happen that even the normal amount of glucose in the body may, through the refusal of the liver to secrete it as glycogen, accumulate excessively in the blood, and the excess may be excreted by the kidneys in the urine. In other words, there may be hyperglycaemia, and consequent glycosuria, merely because of a temporary failure on the part of the liver to secrete from the blood the due amount of glycogen: the saturation point is lowered for the body and hyperglycaemia necessarily follows.

Now one of the most important causes of the lowering of the saturation point is supraemic poisoning, and in this fact lies the true explanation of the transient glycosuria that is associated with carbuncle or gangrene. As an instance of this, Sir Cuthbert Wallace mentions his Case No. 5:

"A woman, aged 65 years, was admitted into the hospital with a carbuncle of the back of seven weeks' duration. The urine contained 300 grains of sugar in the twenty-four hours. The slough was excised, and the sugar disappeared from the urine in nine days, and was still absent six weeks later." There was no symptom of diabetes in this case except the glycosuria, and the diet was unrestricted.

Again, suppose that the saturation point remains steady. Even so the normal man can pass it if he introduce enough glucose into his blood stream. I myself passed it by eating half a pound of glucose at 6 o'clock one morning.

"It has been shown," says Sir Cuthbert Wallace, "that all persons possess a saturation point; that is to say, that sugar will appear in the urine if a certain quantity of carbohydrate is taken at a meal. A healthy man can dispose of 300 grains (say 9 oz.) of glucose at a meal and yet none will appear in the urine. This is not so with a patient suffering from septic absorption, as in such a case 50 grams (say 1½ oz.) of glucose will often pass into the urine." Of his Case No. 8, a man of 31, admitted on May 29th, 1893, with diffuse cellulocutaneous erysipelas of the arm, Sir Cuthbert writes: "The urine was acid, with a specific gravity of 1020, and contained no albumin nor sugar. On the 31st 100 grams (say 3 oz.) of glucose were given, and the urine passed in the next twelve hours was collected and found to have a specific gravity of 1020, and to contain sugar. Fermentation with yeast reduced the specific gravity to 1016 (that is to say, the urine contained four grains of sugar to the ounce). On June 23rd the wounds were healing well, and the temperature was normal. The patient was now given 100, 200 and 300 grams (say 3 oz., 6 oz. and 9 oz.) of glucose on succeeding days, but no glycosuria resulted." In Case No. 10, Sir Cuthbert Wallace writes as follows: "A man, aged 54 years, was admitted into the hospital for a carbuncle on the neck of the size of a saucer, which he had had for six weeks. Fifty grams (say 1½ oz.) of glucose were given on two successive mornings, and on the second occasion sugar was found in the urine, which on admission had been described as '1016, acid, no albumin, no sugar.' Fermentation reduced the specific gravity by four points (that is, the urine contained 4 grains of sugar in 1 oz.). The carbuncle was scraped, and ten days later another 50 grams of glucose were given, and again sugar appeared in the urine. Fifty grams on the two successive days produced no sugar, nor did 75 grams on the next day. A week later the patient was tested up to 150 grams (4½ oz.), but the urine continued normal."

Dr. R. T. Williamson (whose great learning and industry all of us whom he taught at the Manchester Royal Infirmary have reason to remember) quotes Von Noorden as saying that in a healthy person glycosuria will be caused by a single dose taken on an empty stomach of from 180 to 250 grams of glucose (6 to 8 oz.).

Quoting Nauyn, he says that if distinct glycosuria occurs when a man takes 100 grams (3 oz.) of glucose two hours after a standard breakfast of ½ litre of coffee and milk and 80 to 100 grams of bread, then the saturation point is distinctly lowered. Von Noorden found that in four out of fifteen obese persons

temporary alimentary glycosuria was produced by 100 grams (3 oz.) of glucose; of these four individuals two became diabetic several years later." "In traumatic neurosis or neurasthenia there is often a diminished power of sugar destruction; also Ebstein and Asher have shown that traumatic neurasthenia is some times followed by diabetes mellitus." (Williamson's article on Glycosuria in the *Encyclopaedia Medica*.)

Recent Cases.

I have sometimes had under my care women from whom I thought proper to wean their babies, once on account of enterica, at other times on account of some septic condition in the mother. After the weaning the mother's urine would reduce Fehling's solution for several days, the sugar of the milk being absorbed from the breasts into the blood, which, in its turn being surcharged, excreted the superfluous sugar through the kidneys, so that it was found in the urine.

In my own practice, as well as in my own person, I have found reason to be thankful for the new doctrine.

At the South Manchester Poor Law Hospital in 1916 one of my patients was a middle-aged man with a wooden leg. On his first admission, four years before, his bed-card was marked "Diabetic Gangrene," and a surgeon had boldly amputated the leg for gangrene, despite his diagnosis of diabetes, as Sir Rickman Godlee would have done. I found the man quite well, and he had no glycosuria, so I had the pleasure of telling him that, according to a great discovery recently made and proved, he had never had diabetes, but only a peculiar and temporary blood poisoning from his bad leg; that I had myself suffered blood poisoning in the same way, only from carbuncle of the neck instead of gangrene of the leg; and that, as regards diabetes, both of us were as sound as anyone in Manchester. So he went on his way rejoicing, and I wrote "Supraemic Glycosuria" on his old bed ticket.

At an epileptic colony the medical officer found Fehling's test for sugar positive in the urine of a young man suffering from a small but angry boil. He asked me, as a puzzle, whether sugar was present or only one of the rare reducing agents described in the textbooks. I diagnosed supraemic glycosuria, and proved the presence of sugar by the fermentation test. The glycosuria vanished almost as soon as the boil.

A corporal in another war hospital brought me a patient who had been passed in Class A1. I found a large suppurating carbuncle on his neck, and a little glycosuria; no hunger, thirst, emaciation or polyuria. I made the diagnosis of supraemic glycosuria secondary to carbuncle, and the prognosis of early recovery from both carbuncle and glycosuria. I convinced one of my colleagues, but was gently assuaged by others that time would falsify my optimistic prognosis. I soon removed the sloughs, and the glycosuria quickly vanished. Query: "If the private had by chance gone to one of my sceptical brethren instead of coming to me, would he have been discharged from the army as a diabetic?"

Conclusions.

A. To give our textbooks and teachers their due, we must admit that they used to teach us that there was such a thing as "transient glycosuria." The word "transient," however, was of the lowest practical and scientific value, for on the one hand we could never know that the glycosuria was transient until it was gone, and on the other hand the cause of the glycosuria was left undesignated. But the words "supraemic glycosuria" have high value; in diagnosis, for the cause is named; in prognosis, because an early, happy result—life instead of death—is soundly predicted; and in treatment, because common diet may be used and the modern starvation and starch-free diet (a great nuisance) is forbidden.

B. I believe that carbuncle or gangrene secondary to diabetes is not very common, but I readily see why so debilitating a disease as diabetes can be, like other forms of debility, a real predisposing cause for carbuncle or gangrene.

(1) In supraemic glycosuria the sugar is relatively small in quantity. The largest quantity recorded in this paper as having been passed in twenty-four hours is 1400 grains (or 3 oz.). In diabetes the patient commonly passes from half a pound to three-quarters, say, 4,000 to 6,000 grains daily.

(2) Consequently, in supraemic glycosuria we find an absence of the great diabetic symptoms, namely: no hunger, no thirst, no emaciation, no polyuria.

(3) In the case of supraemic glycosuria associated with gangrene there will probably be found enough arterial degeneration in the patient to account for the gangrene without it being necessary to fly to the hypothesis of diabetes.

C. As the supraemic products of gangrene, carbuncle, erysipelas, etc., differ considerably from each other, it is

I have recorded here nothing that happened before 1891, but I suspect supraemic glycosuria in the case recorded by Traube in 1861. "M. Delpech," he says, referring to a great French surgeon of a hundred years ago, "found sugar in a case of carbuncle of lip and chin, which went on to complete recovery."

probable that one sapraemia will differ much from another in its power of lowering the saturation point for sugar. At present gangrene and carbuncle are the most striking and misleading agents in the causation of sapraemic glycosuria, but further investigation will doubtless reveal a long series of such agents differing from each other very much in the power of causing sapraemic glycosuria.

SELF-INFLICTED INJURIES IN CIVILIAN PRACTICE.

BY

A. RENDLE SHORT, M.D., B.S., B.Sc., F.R.C.S.,

ASSISTANT SURGEON, BRISTOL ROYAL INFIRMARY;

AND

CYRIL H. WALKER, M.B., F.R.C.S.,

SURGEON, EYE HOSPITAL, AND OPHTHALMIC SURGEON,
GENERAL HOSPITAL, BRISTOL.

I.—MR. RENDLE SHORT.

A CASE like the following might so easily get a surgeon into undeserved trouble that it seems desirable to put it on record.

A young woman, giving her age as 18, was admitted into one of my wards at the Bristol Royal Infirmary in November, 1915, with a three weeks' history of appendicular colic. I removed the appendix. There were two small ulcers in its mucosa. She healed well and went back to her home in the country. On January 27th, 1916, she paid us a visit complaining of pain in the scar, but nothing abnormal could be found.

In December, 1918, she was readmitted, with the history from her doctor that she had been in the workhouse infirmary for many weeks discharging pus and fragments of a gauze swab from the scar of the appendix operation. He and his partner had opened up the wound under an anaesthetic, but could not find any gauze, nor did the track go through the muscles of the abdominal wall. As it still did not heal, and fresh bits of gauze came out, they sent her up to me.

Naturally I was very perturbed. It is an absolute rule with us never to put a swab in the abdomen without a tape and artery forceps on it, to count all swabs before and after operation, and almost never to use gauze packing; but to err is human. The patient's age was now given as 24. For the first few days after arrival her temperature was high, about 103°. At first the pulse was also quick, but after a while the slow pulse, normal general appearance, and very irregular high temperature led us to give her the thermometer again, just after it had registered over 101°, and we found that in the mouth it was normal. After that she was deprived of her hot-water bottle when her temperature was taken, and it became normal.

Meanwhile the abdominal sinus discharged freely. I opened it up on January 16th, 1919, and found no gauze. The tracks were extensive amongst the abdominal muscles, but did not go through them to reach the peritoneum. I cleaned it all up very carefully, and drained the wound after partially closing it. It did not heal. Some weeks afterwards a piece of selvedge-gauze came out, such as we never use for swabs. This relieved my mind greatly. She was sent home still with a small sinus and returned to the workhouse infirmary. Mentally she behaved and conversed quite normally.

In September, 1919, several more pieces of gauze came out, which were sent me by post. Then she became very ill, and there was a discharge from two openings, one on the abdomen and the other below Poupart's ligament, smelling like faeces. I readmitted her. She now gave her age as 19. On September 22nd I operated, beginning by exploring the abdomen in the middle line. The abdominal cavity was quite normal. The caecum was not adherent to the anterior abdominal wall, and there was no mass in the right iliac fossa. I closed the abdomen again and slit up the sinuses. There was a foul track connecting them, about six inches long, running deep in the subcutaneous fat but not penetrating the muscles. In the deepest part of the sinns was a piece of wool as large as a haricot bean, with a faecal odour. I thoroughly excised the whole track and sewed up the whole incision in clean tissues. Over the dressing we then put on yards and yards of adhesive plaster, completely encircling the thigh and lower abdomen. The operation was performed in the presence of eight or ten most interested spectators, whose names were recorded in the notes as witnesses.

It was, of course, impossible for the patient to get at the wound, strapped up as it was with continuous adhesive plaster, and it had healed up, though rather insecurely on account of deep sepsis, in about a fortnight. One or two small abscesses formed, discharged, and healed up before we could regard the scar as safe. When she went home, soundly healed at last, I roundly accused her of pushing in the gauze and wool herself. She denied it indignantly.

In January, 1920, so her doctor informed us, the scar started discharging again through a fresh sinus, and presently all her urine was passed through this sinus. She became very ill, and nearly died. In June, 1920, she was readmitted to my ward.

She looked thin and ill. There was a large sinus in the lower end of the old appendix incision, through which the whole of her urine escaped. A skiagram was taken, which showed an elongate foreign body lying in the bladder. On June 17th I performed suprapubic cystotomy, and removed a broken piece of a bone knitting needle, four inches long, encrusted with phosphates, which was loose in the cavity of the bladder. When pressed a few weeks after to account for the presence of the needle in the bladder she at first said that her doctor at the workhouse infirmary had lost it in probing the wound, but finally she admitted that she had pushed it into the bladder herself from the abdomen.

When I returned from a holiday at the end of August, though the sinus in the appendix region had healed, the suprapubic opening was still as large as one's finger, and I felt sure that the patient was tampering with it. A catheter had been tied into the bladder through the urethra without hastening healing; on one occasion the catheter was found blocked with wool. Then the end of the catheter disappeared. On August 31st I operated for the fourth time, removed about an inch of the end of the catheter from the bladder, sutured up the suprapubic wound, and secured it with an anchored dressing. To give it a better chance to heal I dilated the urethra sufficiently to give her incontinence for a week or two. By this means the wound eventually healed up, and she was sent out well.

I have recently heard from her doctor (November, 1920) that the suprapubic wound is open again. She makes no secret this time that she did it herself.

It was quite clear to us, from the time of the operation in January, 1919, that these sinuses were the result of self-inflicted injuries, and that the gauze had been pushed in by herself, for the following reasons, quite apart from the routine precautions taken at the original operation in 1915:

1. The original wound healed well, and stayed healed for years.
2. Not one swab, but several small pieces, came out.
3. The sinus did not penetrate the abdominal muscles, so that any swab must have been left, not in the abdomen, but in the abdominal wall, which is scarcely credible.
4. She had already been detected "faking" her temperature.

When later, in spite of two negative explorations of the sinus—one at home and one by me—a piece of selvedge-gauze, a lump of wool, and enough separate fragments of gauze to constitute four or five swabs, were found in the track, of course the nature of the case became obvious, and was confirmed by the facts that healing did not take place when she could get at it, but union by first intention took place when she was thoroughly strapped up. Nevertheless, there was a stage when an action at law for negligence in leaving a swab behind would have been all too likely to succeed, and the putting of this case on record may be a protection to some surgeon unjustly accused in the future. Legal proceedings were never threatened against me.

The motive and the state of the patient's mentality are hard to fathom. That she should be an inmate of a hospital and a workhouse infirmary for over two years, and inflict such injuries upon herself as to push a thick bone needle from the right iliac fossa into the bladder, simply to escape work or to excite sympathy (of which she got very little in Bristol), seems hard to believe, yet the only evidence to be found of unsoundness of mind is furnished by these actions. Her behaviour and conversation were otherwise normal.

Perhaps, in view of the incredible nature of the case, it may be as well to state that the facts can be vouched for by a whole succession of my house-surgeons and dressers, and the patient and "finds" have been shown to various surgical meetings. I owe a considerable debt to the acumen of my ward sister, Sister Julia Gross, in clearing up the nature of the case.

One somewhat similar example of a self-inflicted injury has come under my care. Some years ago, when our dermatologist was away at the war, I was asked by the acting out-patient physician, Dr. W. A. Smith, to see a girl, aged about 14, because she got a peculiar rash on her face every Wednesday afternoon at about 1 o'clock. The distribution was that of lupus erythematosus, but the characters were those of irritant dermatitis. Of course the extraordinary time-relation made it quite certain that it was an artefact, though we inquired if there was anything special about her diet on Wednesdays; there was not. I suggested having her up on Wednesday morning

and putting on a lint and ointment face-mask. This was done, and as her mother refused to take her home through the streets like that we had to admit her. On that Wednesday no rash appeared, and she went home next day. On the following Wednesday the rash reappeared, but obviously we could not find a bed for her every week. Why she did it I do not know.

II.—MR. CYRIL WALKER.

It is not easy to understand the motive which induced the girl whose case is to be related to inflict so much pain upon herself, but I have very little doubt that she was in some way tampering with her eyes long before the pieces of cotton-wool and thread were discovered.

L. G. came to me at the Bristol General Hospital as an out-patient in 1892 when she was 6 years old. She was then suffering from phlyctenular conjunctivitis and keratitis. She soon recovered under the usual treatment, but had very frequent recurrences, so that for some eight or ten years she was almost constantly under treatment. When she was 8 years old she had typical molluscum contagiosum of the eyelids—a disease, by the way, which is seldom seen amongst ophthalmic out-patients now. When she was 12 she developed tuberculous glands in the neck, and in consequence underwent three extensive operations between the ages of 15 and 17. The corneae were at that time so much damaged by recurrent strumous keratitis that she could only read big print, and no examination of the fundi was possible. When she was 18 she had an extremely severe and intractable attack of keratitis affecting both eyes, and accompanied by great photophobia and intense spasm of the orbicularis. She was an in-patient for some months, and towards the end of her stay in hospital it was noticed that on two or three occasions a tiny piece of cotton-wool or of thread from a bandage was found in the conjunctival sac. She was not definitely accused of having introduced these foreign bodies, but she was questioned about it and told to be very careful not to touch her eyes herself. Her general condition slowly improved, and her eyes gradually quieted down. The corneae had been rendered very opaque all over by the interstitial keratitis. No fundus reflex could be obtained, and her vision was reduced to bare perception of light. The corneal condition was not enough to account for such great loss of sight, and it must be assumed that she had choroiditis at the same time as the keratitis.

Soon after this, as her health was fairly good and there seemed to be no further prospect of recovery of sight, she was admitted to the Blind Asylum as a resident pupil. Attacks of conjunctivitis with keratitis soon came on, and after several attacks Dr. Flemming found that she deliberately introduced pieces of the thick paper used for Braille writing under her lids. On three occasions a piece as large as the finger-nail was found in her right eye. She was very sternly spoken to by Mr. Cross, and an exaggerated account of the risk she ran of setting up dangerous, perhaps fatal, inflammation induced her to desist from any such pranks again. Since then she has had no similar attacks.

Such practices amongst ophthalmic patients have often been recorded, but usually the immediate object is obvious—to excite sympathy, to prevent returning to work, or to gain admission to hospital. I recall the case of a young woman who was much crippled with arthritis, and who, besides attending at the electrical department, repeatedly for some years came to my ophthalmic out-patients with "conjunctivitis" which was never at all severe and left no trace. It always got well quickly with boric lotion and mild astringents. On one occasion, as she was leaving the consulting-room, she dropped a small piece of hard dry white soap. She picked it up hastily, but not before I had seen it. On being asked what it was for she made no reply, but turned very red. She had no more conjunctivitis after that day, though I often passed her on her way to and from the electrical department. The inference is almost irresistible that the conjunctivitis was self-inflicted, and that the soap was the agent used.

NOTES ON

ONE THOUSAND CASES OF BILHARZIASIS TREATED BY ANTIMONY TARTRATE.

BY

F. O. LASBREY, M.B., AND R. B. COLEMAN, M.B.,
C.H.B., C.H.B.

PRINCIPAL AND ASSISTANT MEDICAL OFFICERS, CHURCH MISSIONARY SOCIETY'S HOSPITAL, OLD CAIRO, EGYPT.

THE reason for adding still another chapter to the rather numerous articles written on the subject of the treatment of bilharziasis by intravenous injections of antimony tartrate is the fact that up to the present time the con-

clusions arrived at have been based on the investigation of a comparatively small amount of clinical material, whereas we have been able to avail ourselves of the exceptional opportunities which Egypt affords for making observations on very large numbers of patients.

We can add little fresh information to what has been noted in previous articles on the subject, but with the records before us of 1,000 individuals who have undergone treatment at our hands, we are able to verify what has already been written on the subject, and venture to think that our testimony to the efficacy of the antimony tartrate treatment may be of some value, and a report of the results of the treatment of our first thousand cases of general interest.

Since June, 1919, injections of antimony tartrate in accordance with Dr. Christopherson's observations have been the routine treatment for bilharziasis at the Church Missionary Society's Hospital, Old Cairo, and we are now injecting from fifty to seventy cases a day: both urinary and rectal bilharziasis are being treated, but the former in a much larger proportion.

Dose.

In cases without contra-indication the usual method has been to start with 1 grain as the initial dose, increasing by $\frac{1}{2}$ grain at each injection, so that the maximum of 2.5 grains is reached at the fourth injection: this dose is then repeated at all subsequent injections. Injections are given on consecutive days for the first six days, and then on alternate days. The dose is altered in the following cases: Weak men and most women take slightly smaller doses. Children take much smaller doses in proportion to their size and condition. All cases showing much reaction—for example, fever, loss of appetite, etc.—are given smaller doses, and some are given longer periods between injections. It is worth while mentioning that the liberal dosage mentioned above is found necessary in order to cure the disease within a limited period. Our patients, most of them farm labourers, are unwilling to prolong their stay in hospital unduly. On the other hand, it appears that a much smaller and more gradual administration of antimony is equally effective. Quite small doses spread over a considerably longer period appear to cure the disease, the main point being the cumulative effect of about 20 grains of the drug.

Examination.

All cases are submitted to microscopical examination before beginning the course. A re-examination is made after the sixth dose, and subsequently after every dose, and a daily report made with regard to the presence of bilharzia eggs, their condition, and the relative proportion between dead and living eggs in each specimen. When all eggs are found "dead" injections are stopped. The urine is examined again on the two following days, and on three consecutive reports of all eggs being dead the patient is considered free from bilharzial infection. Unfortunately some patients after one report of "all dead" will not stay for further examination. Examinations are made as follows: The urine is allowed to stand for a quarter of an hour, and the deposit pipetted off for examination. If the result is negative the lower layer of the urine in the specimen glass is centrifuged and the deposit examined. Dead eggs are shrivelled and black. No organism is visible in the eggs, and they fail to hatch out on the addition of water.

Rectal cases are more difficult to pronounce free from bilharzial infection, for sometimes eggs do not show for days together. Consequently in these cases we do not usually depend on microscopical examination, but give the full course of twelve doses, amounting to 27 grains of antimony tartrate.

Statistics.

In 1919 (June to December) 370 cases of bilharzial disease were treated, while in 1920 (January to August) our books record 630 cases. Proper records of the first 150 cases in 1919 were not kept, and of the remaining 220 we find that 44, or 20 per cent. of the total number, received less than six injections each. This is not surprising considering that the antimony method of treatment is by no means free from discomfort. Moreover, treatment was abandoned in the case of a few where adverse symptoms, such as marked debility, anorexia, etc., supervened after a

few injections. It may be remarked, however, that many of those who took only a few injections experienced remarkable alleviation of symptoms. Of the remaining 176 cases:

24 had 7 to 9 doses, totalling an average amount of 18 grains,
92 had 10 to 12 doses, totalling an average amount of 25 grains.

Of these, 81 were pronounced cured by the above tests, the majority of them having taken the larger number of doses, that is, an average amount of 25 grains. This means that 81 individuals, or 42 per cent., were proved cured out of 176 who more or less completed the course of treatment. Almost without exception those not pronounced cured were benefited to a very large extent, and the examinations showed a large proportion of dead eggs, but it is not our method to call them "cured" so long as any living eggs appear, or even in the event of no eggs at all being seen. Dr. Christopherson emphasizes this latter point, and we agree strongly as to its importance. Again, the very marked relief of symptoms which many experience is in itself a cause of a certain percentage of patients not persevering in the treatment after the haematuria and general distress have disappeared; thinking themselves cured, they choose to leave hospital without waiting for an examination, or in spite of the fact that living eggs are still demonstrable in the urine.

By 1920 the antimony method had passed the tentative stage, and patients were beginning to seek treatment with greater confidence; consequently the 1920 records show an increasing number of cases and a higher percentage of cures.

Of the 630 cases treated between January and August, 1920, 20.6 per cent. did not take as many as six doses, the continuance of the treatment being contraindicated in a few, while the rest did not persevere. Of the remaining 500:

13 had 6 doses, amounting to 12 grains
57 had 7 " " " " " " " "	... 14.5 "
56 had 8 " " " " " " " "	... 17 "
138 had 9 " " " " " " " "	... 19.5 "
107 had 10 " " " " " " " "	... 22 "
70 had 11 " " " " " " " "	... 24.5 "
59 had 12 or more doses, amounting to 27 "

Of these 500 we find 348 were pronounced "cured" according to the above definition—that is, nearly 70 per cent. The increase in the proportion cured over the first series is not due to any difference in the treatment or its results, but mainly to the course becoming more popular, and the consequent willingness of a greater number of patients to wait for its conclusion. As far as our experience goes, we find that all cases strong enough to take the treatment become cured if they continue with it; this year's series produced more "cured" with a slightly smaller dose, the desired result being most frequently obtained after nine, ten, or eleven doses, as follows:

After 9 doses 97 were "cured."
After 10 doses 79 were "cured."
After 11 doses 64 were "cured."

These amount to just 70 per cent. of the total number of cured, and this means that the usually effective dose is from 19.5 to 24 grains, and exactly bears out Christopherson's opinion that the dose of antimony tartrate required for an adult is between 20 and 30 grains, and that it is generally nearer 20 than 30 grains.

Mortality.

In the total series of 1,000 cases we had 10 deaths which could in any way be attributed to the treatment or to the disease itself, a proportion of 1 per cent. Six deaths occurred in the first series of 370 patients, and only 4 in the second series of 630 cases. Thus the percentage during 1920 has been considerably reduced. We regard this as very satisfactory when the poor condition of so many of the patients is considered. Not a few of those who apply for treatment are in a very miserable state. In some the kidneys are affected, and the urine shows a very low specific gravity. Eager to grasp at any possibility of cure, it is only fair to give these physical wrecks the chance of recovery. If they stand the injections well these are continued; if they develop bad symptoms the course is abandoned. We attribute the lessened mortality in 1920 to a greater watchfulness and caution in weeding out patients exhibiting marked intolerance for the drug, to more gradual administration, and to a great moderation of dosage in very feeble subjects.

The usual symptoms preceding death are total loss of appetite, extreme debility, and complete apathy. The patient curls up in bed and lives perhaps for some days before the fatal issue. Then a sudden effort, such as rising from bed, is followed by fatal syncope. No death took place immediately after an injection, and usually some days supervened between the last injection administered and the fatal issue. The total amount of antimony administered in several of these cases was very small.

Technique.

As we have to deal with a very large number of cases, it is important that the routine should be as simple as possible and the work reduced to a minimum; this department has been added to the already heavy daily round of a large hospital with all its varied medical and surgical work, without any addition to the staff. An Egyptian orderly has been trained to do all the microscopic work, and all cases are examined by him before beginning the course and again after the sixth and every subsequent injection. He sends in his reports daily to the sister in charge of the section. The latter supplies every patient with a card on which is marked his name, number, and the date and amount of each dose; all this is also noted in her book of records together with notes concerning the presence in the urine of bilharzia eggs, blood, pus, the urinary specific gravity, etc. Each morning, before the arrival of the doctor, she marks up the cards for that day and the patients are lined up. Any doubtful cases are reserved for further inspection. The antimony tartrate is supplied in tablets for solution, especially made by Messrs. Parke, Davis and Co., containing 10 grains each. From these a sterile solution is made containing 1 grain in 20 minims. This is dropped from a drop bottle into a sterile cup and further diluted to make up about 10 c.cm., which is then ready to be drawn up into the syringe. A 10 c.cm. glass syringe is used, with two or three needles. All the apparatus is boiled before commencing work. After each injection sterile water is drawn up into the syringe, which is then rinsed out and the needle is removed and immersed in a glass of rectified spirit.

The patient holds up his record card, the sister measures out the doses indicated thereon, and the doctor draws up the solution into the cleansed syringe and adjusts a needle. The patient sits on a chair with his arm extended on a table and his fist clenched. An Egyptian orderly firmly compresses the upper arm with one hand and strokes up the forearm with the other; he paints iodine on the bend of the elbow, and the doctor injects into a prominent vein, the orderly releasing his pressure, and the patient opening his hand. After injection no bandage or dressing is used, but the patient holds his arm up for about five minutes. In this way we inject patients daily at the rate of more than sixty an hour. Occasionally some patients, more especially women and children, have very indistinct veins, and in such cases some trouble is experienced now and again in finding the lumen of the vessel, but fortunately these are few in number. Great care is taken not to let any fluid escape into the tissues. Should this accident occur, the patient feels it at once and says so. If only a drop or two escapes a painful arm results, necessitating the application of fomentations, etc. In the early months we had several such mishaps, one or two causing local abscesses, but now with increased practice we very rarely get any trouble at all.

It has been questioned whether our sterilization is sufficient, especially in that we do not boil the syringe after each injection; but taking into consideration the nature of the fluid injected and the immersion of the needles in spirit before each operation, the method is regarded as adequate. Moreover, in the whole series no case has exhibited the slightest sign of sepsis from faulty sterilization.

Accommodation for Patients.

The majority of those taking the antimony course are in-patients, some of them occupying beds, but the larger number lying on mats in our large open-air "anaemia pavilions." The reason for this is that most of them also suffer from ankylostomiasis, and are being treated for that ailment at the same time. The injections are not begun until two days have elapsed after the patient's first dose of chenopodium oil or thymol with the accompanying fasting, etc., and likewise they have a few days' rest before the

subsequent doses of these parasiticides. A considerable number, however, take the antimony course as out-patients, attending hospital regularly for their injections.

Complications.

Many patients have complications due to the disease, which are appropriately dealt with. Vesical calculus is treated by lithotripsy or suprapubic cystotomy, the injections being continued. Bilharzial growths of the perineum, often resulting in urinary fistulae, are treated by operation in addition to injections. It is remarkable to notice the influence of the injections on the healing of these fistulae; down to a year ago they used to be our most chronic cases, often taking months to heal up after operation. Now the average case heals in about twenty days. Rectal cases showing friable, cauliflower tumours of the mucous membrane, many of considerable size, are treated by ligature, and in the case of small growths by removing as much as possible by scraping with the finger-nail and swabbing with zinc chloride solution. Again, the influence of the injections on these growths is very marked, as many of them quite disappear in a comparatively short time after scraping. Previously two or three operations were necessary. As regards other complicating conditions a very large proportion of the cases, as mentioned above, also suffer from ankylostomiasis, and a considerable number have pelagra. Nephritis is observed occasionally, and in several weak patients with this complication the treatment had to be abandoned.

Late Results.

In a country like Egypt it is always very difficult to follow up cases and to get satisfactory statistics, but we have inspected several patients some months after treatment who testify to the complete relief of all symptoms. Microscopical examination, moreover, still shows only "dead" eggs. The same result is found in several of our own workers who took the course a year ago. In no case have we seen living eggs reappear after completing a successful course, though obviously this might be possible owing to reinfection.

CONCLUSIONS.

1. The results of the antimony treatment on a large scale bear out in a remarkable way the findings of those who have recently written on the subject, and especially of Christopherson, to whose original research is due the fact that bilharziasis need no longer be regarded as an incurable ailment.
2. As most ordinary patients are unwilling or unable to make a protracted stay in hospital, it is necessary to hasten the antimony course and thus give liberal doses; yet in cases where it is possible we urge a more gradual administration of the drug, and in this way we believe risk will be reduced to a minimum, while the eventual cure will be as surely effected; 20 to 25 grains of antimony tartarate is, in our experience, the average amount required to effect a cure. While a less toxic substance than antimony tartarate would be welcomed, we are persuaded that its toxic effects can be largely eliminated by cautious administration.
3. To reduce the mortality a very careful investigation of cases is necessary. "Rests" should be given on the occurrence of any untoward symptoms, the dose lessened at the least indication, and the course immediately abandoned in cases showing marked intolerance.
4. The above technique is recommended as being simple and rapid where large numbers of patients are to be dealt with, as, for instance, when any attempt is made to eradicate the disease in infected districts.
5. It is noteworthy that the successful surgical treatment of complications dependent on bilharziasis, such as urinary fistulae and rectal papillomata, is enormously facilitated by the elimination of the causative factor.

THE third annual meeting of the Board of Governors of the League of Red Cross Societies will be held in Geneva on March 28th. The Board contains representatives of the Red Cross of the United States, Great Britain, Australia, France, Italy, Japan, Spain, Sweden, Brazil, Switzerland, Argentina, Belgium, Denmark, and Serbia. The chairman is Mr. Henry P. Davison, of the American Red Cross, and the vice-chairman the Director of the League, Sir David Henderson.

STENOSIS AT THE INTERNAL MEATUS AFTER SUPRAPUBIC PROSTATECTOMY.

BY
ANDREW FULLERTON, C.B., C.M.G., M.Ch.,
F.R.C.S.I.,
SURGEON, ROYAL VICTORIA HOSPITAL, BELFAST.

ALTHOUGH Freyer's operation of suprapubic prostatectomy, correctly performed, is rarely followed by serious after-effects, a recent article by Thomson Walker¹ shows that stenosis at the vesico-prostatic orifice is not a very uncommon occurrence. In a certain proportion of cases after prostatectomy it is difficult or impossible to pass a catheter into the cavity of the bladder.

even when the patient does not complain of any difficulty in micturition. The instrument hitches against a diaphragm roofing the remains of the cavity once occupied by the prostate. The point of the instrument can be moved more or less freely in a space in front of the rectum and behind the bladder, and the injection of fluid, unless very slowly performed, is apt to give rise to pain. The fluid, however, if slowly injected may find its way into the bladder. The difficulty in introducing the catheter is due, first, to the absence of the guidance of the prostatic urethra, and, second, to the fact that the vesical orifice of the prostatic cavity is not in alignment with the direction of the urethra. It is, in fact, difficult to hit off with the point of the catheter the vesico-prostatic opening. If, in addition, this opening has contracted, the difficulties are much increased. (See B. in diagram.)

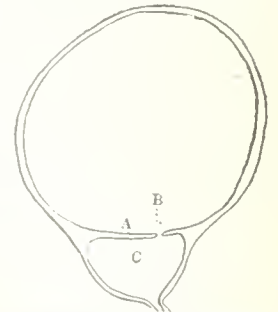

A, Vesico-prostatic septum.
B, Stenosis of vesical orifice.
C, Prostatic cavity.

The following are illustrative cases:

CASE I.

In July, 1914, I removed an enlarged prostate and a villous growth in a patient aged 70 years. In November of the same year he returned, as directed, for cystoscopic examination to ascertain if any recurrence of the villous growth had taken place. I found it impossible to introduce the cystoscope, though the patient denied any difficulty in micturition. After trying several catheters and dilators I was able to pass a small instrument and to dilate gradually the internal opening sufficiently to admit the cystoscope and destroy with the high frequency current a commencing papilloma. In December of the same year I again had difficulty in dilating him sufficiently to pass the cystoscope. In September, 1915, I passed the cystoscope once more, and again destroyed a small papillomatous bud. Immediately after this I went abroad and did not see the patient again, but I ascertained that he remained well until his death from apoplexy in September, 1919, at the age of 75.

CASE II.

In April, 1919, I removed an enlarged prostate in a patient aged 61 years. Fourteen days after his operation he could hold his water for six hours and pass it in a vigorous stream. In May the suprapubic wound began to leak, and I attempted to pass an instrument into the bladder, but only succeeded in getting in a fine catheter. The wound healed in a few days and remained firm until June, when it again leaked for a few days. I saw him subsequently for cystitis, and tried to pass a catheter to wash out his bladder, but failed absolutely. As his symptoms were slight he refused to have anything further done. I have seen him several times since, and he informs me that he is passing water freely and without pain.

CASE III.

A third case gave me a good deal of trouble. The patient was aged 64 years. I removed his prostate in May, 1919. He passed urine on the twenty-sixth day, but leaked a little from the suprapubic wound on micturition for a fortnight after. From this on he was well, and he left the nursing home apparently well on the road to recovery. It was evident, however, as time went on that he had not obtained the usual relief from prostatectomy. He complained of frequency and pain, passing and retaining water at a time with much difficulty and strain. The urine contained a good deal of pus. In March, 1920, an attempt was made to pass an instrument to wash out his bladder. All kinds and shapes of catheters and dilators were used, but none of them could be got to enter the bladder. Fluid injected at the meatus was tolerated, and disappeared, presumably into the bladder. On March 19th, 1920, cystotomy was performed through the suprapubic scar. The bladder was empty. The prostatic cavity was roofed over by a

membrane in which could be felt and seen a small umbilicated opening in the middle line anteriorly, admitting an ordinary probe (see in diagram). The prostatic tent-like roof was slit from before back in the middle line. As the incision was prolonged backwards it was found that the septum became thicker as it passed back to become continuous with the bladder wall. When the operation was completed there was a deep and wide sulcus bisecting the base of the bladder and throwing the prostatic and vesical cavities into one. A drain was inserted and the bladder irrigated daily. On April 2nd the wound was dry, and the patient was able to pass water in a good stream. On May 7th a full-sized dilator passed easily into the bladder.

In order to avoid this complication I have recently taken the precaution of slitting posteriorly with scissors the vesico-prostatic septum as far as its junction with the bladder wall immediately after removal of the prostate. This step is facilitated by grasping the margin of the septum on each side of the middle line with Lane's tissue forceps and cutting between. If the line of incision is clamped by pressure forceps before cutting, bleeding is avoided.

It might be desirable to pass full-sized dilators at intervals for a time in cases in which this complication is suspected and has not been provided for at the primary operation. Thomson Walker, in the article referred to, draws attention to this obstruction, and describes a method of dealing with it. He also extends the operation of Freyer to prevent its occurrence by removing a wedge with the base forwards, from the posterior lip of the prostatic-vesical opening.

I am indebted to Mr. R. H. Hunter for the accompanying diagram.

REFERENCE.

¹ Thomson Walker: Haemorrhage and Post-operative Obstruction in Suprapubic Prostatectomy, *Brit. Journ. Surg.*, vol. vii, No. 28, April, 1920.

Memoranda:

MEDICAL, SURGICAL, OBSTETRICAL.

HERPES AND VARICELLA.

THE following series of cases apparently proves that varicella can be contracted from a patient suffering from herpes, and vice versa.

Just before Christmas a school child was brought to me suffering from herpes on the thigh and buttock. On January 10th and following days several cases of varicella occurred in the village among school children.

On January 17th I was called to see a man aged 35 with supraorbital herpes. Several other children went sick with varicella about February 1st.

On February 10th I saw a man with occipital herpes. There was another batch of children down with varicella on February 14th, and this morning (February 19th) yet another man came to the surgery with supraorbital herpes.

So far as I can make out none of the patients with herpes can have contracted it directly from either of the other patients with herpes, and varicella has apparently acted as a connecting link between them.

The population of the village is only about 1,000, so the occurrence of four cases of herpes at about the same time is unlikely unless it is to some degree infectious.

Stokenchurch, Bucks. E. L. ELLIOTT, M.B., B.S.Lond.

CONCURRENT HERPES ZOSTER AND VARICELLA.

ON November 10th, 1920, I was asked to see, in consultation, a medical student, aged 22 years, who was suffering from herpes involving the upper branches of the right fifth cranial nerve. The history of the case was that on October 31st he began to suffer from intense neuralgic pain in the right side of the forehead and scalp and in the right eye. On November 6th herpetic vesicles appeared on the forehead and scalp over the skin area supplied by the ophthalmic division of the right fifth cranial nerve, and the pain was now so severe as to prevent him from sleeping, and at the same time evidently much diminishing his self-control. I ordered him some butyl-chloral hydrate as a sedative, and seeing him again the following day, found that herpetic vesicles had appeared on the skin supplied by the same division of the fifth left cranial nerve. On

November 12th, that is, six days after the initial herpetic eruption, a generalized varicellar eruption came out on the trunk, upper and lower limbs. There was no pain from the new eruption, and it disappeared in about six days, leaving no scars, whilst the initial vesicles took a further fourteen days to heal, leaving extensive scarring of the right side of the forehead.

ROWLAND HILL, M.D., M.R.C.P.Lond.,
Assistant Physician, Be-fast Hospital for
Sick Children.

TREATMENT OF LOCAL LEISHMANIASIS.

WITH regard to Colonel Erskine Risk's treatment of Delhi boils with solid caustic potash, noted in the *JOURNAL* for February 19th, p. 267, I may state that I have used Loeffler's methylene blue with favourable results in this affection. Loeffler's methylene blue has a small quantity of caustic potash (KOH) in it, and I suppose this ingredient was the curative agent. Painting this blue solution over the sores twice a day proved efficacious in a week. The use of solid caustic potash on the face anywhere near the eye might be fraught with discomfit if not with danger.

C. DONOVAN,

Faringdon, Berks.

Lieut.-Colonel I.M.S.(ret.).

A BULLET IN THE CAUDA EQUINA.

THE following case seems worthy of record because of the site of injury, the safe removal of a foreign body from such a delicate situation, and the comparatively slight symptoms produced during a period of five years.

Pensioner E. was admitted to the Ministry of Pensions Hospital, Neath, with a history of a gunshot wound of the left buttock. He complained of swelling in the feet, with numbness and inability to bend down owing to pain in the back. His history showed that in April, 1915, he received a wound in the buttock while in charge of a party leaving a front line trench, and he fell over some barbed wire, his legs having "given way." He remained there some hours before being moved to the casualty clearing station. From there he was sent to Bethune and later to Boulogne, where, he states, he was unconscious for several days. On recovery he was sent to England "suffering severely in the back," and in due course he was discharged as unfit in September, 1915. From this time to 1917 he was able to get about fairly well walking with sticks, but with occasional attacks of pain and numbness, especially in the left leg. Late in 1917 he commenced light work which he continued until admitted to this hospital in October, 1920. X-rays revealed a foreign body lying in or around the spinal canal, at the level of the interspace between the third and fourth lumbar vertebrae, and at an approximate depth of 2 in. from the skin. As the pressure symptoms were becoming more marked Major Alwyn-Smith, D.S.O., F.R.C.S., visiting orthopaedic surgeon, decided to operate. When the spines of the third and fourth lumbar vertebrae were removed dense scar tissue was found around the laminae. The latter were removed very carefully by chisel owing to the depth of the wound and its limited extent, and haemorrhage, at times free, was controlled by packs of adrenalin. The dura mater now exposed was found thickened by an annular mass of scar tissue, which was dissected off and the dura incised. A small quantity of cerebro-spinal fluid escaped, necessitating rapid elevation of the foot of the operating table. On palpation the cauda equina was found to be hard, and had a resistant feeling which was evidently due to some foreign body lying within. Further cautious dissection revealed a bullet lying longitudinally, apex upwards, embedded in scar tissue. This foreign body was removed from the cauda equina, the dura stitched, and the operation completed. No untoward symptoms or signs arose, and the wound healed rapidly. In a few days a plaster spinal jacket was applied, and this was worn for six weeks. The patient was discharged well, with all movements normal, and with no loss of sensation.

I am indebted to Major Howard, medical superintendent, for permission to publish this case.

D. H. VICKERY,
Senior R.M.O., Ministry of Pensions Hospital,
Neath, Glam.

IT was reported to the London County Council on February 8th that during the three months ending with September last 360 samples of milk from twenty-four English counties were taken at London railway stations, and 15 (or 4.16 per cent.) proved to be tuberculous. Of 608 cows at twelve farms situated outside the county of London which were examined by the Council's veterinary inspector, 13 were found to be affected with generalized tuberculosis. The usual arrangements were made with the farmers for the disposal of these animals.

Reports of Societies.

SKIN DISEASE: ITS RELATION TO INTERNAL DISORDER.

A DISCUSSION on skin disease in its relation to internal disorder took place at the Medical Society of London on February 14th. Sir F. W. MOTT presided.

Sir JAMES GALLOWAY, in the course of his opening paper, spoke in the first place of the erythema group of cutaneous affections. The special eruptions of the acute exanthematous diseases seemed most probably to result from the direct action of the infecting elements, protozoal or bacterial, on the skin. The considerations which led to this conclusion were the distinctive character of the eruptions in each disease, and the fact that in certain of the diseases the organism recognized as the cause of the disease had actually been found in the exanthem. Special opportunities had arisen for the careful study of erythematous reactions as a result of the use of alien antitoxic serums in the treatment of certain of the infective fevers. Variations from the normal reaction occurred, due to what was apparently the increased or the diminished sensibility to the action of the alien protein. Two facts stood out clearly for recognition from the clinical point of view: (1) as a result of absorption of proteins alien to the invaded organism, eruptions made their appearance closely similar to the erythema group of skin diseases; (2) these eruptions varied in degree, severity, and time of incidence, the variations depending on stages of increased or diminished sensibility which might be acquired by artificial methods. The speaker then dealt in particular with erythema exudativum. His conclusion was that general or focal infections were capable of admitting toxins into the body which produced destructive influences, and also that substances resembling more closely the alien proteins producing the protein reactions—serum sickness and analogous conditions—might find their way into the circulation in visceral disease. Erythema nodosum he thought might be a "true" eruption, the manifestation of a specific circulating poison producing local damage, just as the special eruptions of the specific fevers. Lupus erythematosus was thought by some to be caused by the absorption of toxins from chronic tuberculous foci, though the disease occurred sometimes in its most widespread and dangerous manifestations where there was no evidence or suspicion of tuberculosis in the ordinary sense. In herpes gestationis he thought it fair to assume that the embryonal cells and their products might act as an alien protein. Diseases of the skin associated with functional disturbance of the blood vessels required much further observation before their causes could be understood, though disease of the blood vessels causing obstruction to the supply or return of the blood produced more easily understood changes from malnutrition, secondary pyogenic infection, and necrosis. The nervous system, both central and peripheral, had long been held responsible for influencing disease of the skin, but it was not easy to trace the actual influence, even when it might be strongly suspected in individual cases. The most interesting instance of close relationship was in herpes zoster, which had directly to do with a peculiar, often haemorrhagic, inflammation of the posterior root of the ganglia of the spinal cord and the analogous ganglionic structures, but the series of cutaneous reactions and injuries associated with disease of the spinal cord and brain were not so easy of explanation. Finally, Sir James Galloway dealt with the relationship of the skin to disorders of the abdominal and other viscera. He spoke of it as a matter of surprise, considering the close physiological relationship between the kidneys and the skin, that disease of the kidney was not more often accompanied by skin manifestations. There were very few examples of skin outbursts occurring in the course of "Bright's disease." It was not infrequent to find a record of albuminuria, haematuria, and nephritis in cases of erythema multiforme; but the presumption in such cases was that the cutaneous disease and the renal disorder were manifestations of the same toxic cause. Many remarkable manifestations on the skin occurred during the course of disorders of metabolism. It seemed that in glycosuria and allied conditions substances derived from

the imperfect metabolism of the fats might be deposited at certain vulnerable points in the body, and by their presence produce local irritation and multiplication of the connective tissue cells; or, on the other hand, that poisons due to metabolic errors might damage these areas, and that the lipid substances were formed locally in consequence, and aided in the production of the characteristic nodule in, for example, xanthoma. Lichen planus seemed to occur with undue facility in persons suffering from glycosuria and allied disorders of nutrition. Sir James Galloway concluded with a reference to lymphatic leukaemia and to Hodgkin's disease, in both of which similar phenomena affected the skin, taking the form in both cases either of tumours or of remarkable pruriginous reactions without definite tumour formation. The evidence seemed to point strongly in both cases to the infective origin of the classes of disease of which these two conditions were examples.

Dr. ARTHUR HALL (Sheffield) dealt with the functions of the skin as a surface organ, which, he said, except as a heat-regulating mechanism, played no obvious part in the general metabolism of the internal organs. The importance of the relation to the skin of things outside the body quite outweighed the importance of the relation of the skin to the domestic functions of the body; the skin was a coastguard rather than a part of the merchant service. If the individuality of the skin as an organ were kept in mind, greater progress in knowledge would be made than if the skin were regarded as a kind of screen upon which the clinician could view what was going on in the organs beneath. He believed that many changes in the skin now attributed to internal disorders were capable of explanation as natural reactions of the skin to definite stimuli, and though there were many skin affections which obviously were due to internal disorders—the rashes of the exanthemata, for instance—even there the individuality of the skin could not be overlooked. A list of so-called skin diseases due to changes within the body could easily be drawn up, and would not be very long; a similar list of affections due to causes from without would be longer, but a considerable list of skin diseases would still remain unclassified, and these would include many common affections, amongst them many of the conditions once called eczema. In trying to ascertain the truth with regard to these, the part which the skin itself played must always be borne in mind. It was often noticed that a patient who was being treated for some trivial local eruption suddenly developed a widespread acute weeping dermatitis; this followed usually from the application of some new material to the skin, often of apparently harmless character. In his view, the acute outbreak did not depend solely upon the material applied, but upon the susceptibility of the individual upon his neuro-cutaneous reaction to that particular material. Such irritants as primula or phenylhydrazin were not universally irritating; most people could handle them with safety, yet in those whose skins were susceptible the violence and extent of the reaction went far beyond the duration or extent of contact. He gave a history of an interesting case in point. This type of skin reaction to some particular substance was more common than was thought, and there was something more about it than the anaphylactic phenomenon. But our knowledge of the defensive reactions of the skin was not yet sufficient to permit of very definite conclusions.

Dr. E. W. GOODALL took up the question of anaphylaxis. There were some, he said, who held that an attack of an acute infectious disease was an anaphylactic reaction; in his own view an attack of an acute infectious disease was neither an anaphylactic phenomenon, nor was it brought about in exactly the same way as an attack of serum sickness. The symptoms of an acute specific infectious disease were due to two main causes—a special toxin and the common protein cleavage product.

Dr. E. GRAHAM LITTLE referred in particular to lupus erythematosus. He was reluctant to accept a tuberculous causation of this disease, chiefly on the ground of what he had seen in children. He had never seen any evidence of this association among the patients in a large children's hospital, where many tuberculous children were received.

Dr. H. W. BYRNE agreed with Dr. Graham Little in thinking that there was no definite evidence of tuberculous causation of lupus erythematosus. Certain cases exhibited stigmata which were supposed to indicate—and probably did indicate—an infection with tubercle in early life, and

cases had been published in which the acute form of lupus erythematosus had been associated with active phthisis or even general tuberculosis. But, speaking of his own cases, in not a single one had he found any evidence of active tubercle. In all his cases he had recovered the virulent long chain streptococcus, sometimes in pure culture. The primary foci were usually the teeth or tonsils, sometimes the nasal sinuses. There was a very close relationship between lupus erythematosus and rheumatoid arthritis.

Dr. H. G. ADAMSON said that a great many skin diseases which were formerly supposed to be due to internal disorders were now discovered to be the result of external causes entirely. Even scabies and ringworm were at one time thought to have an internal cause. Not all skin diseases were external in origin, of course; some were due to micro-organisms brought to the skin by the blood stream from internal affections, as in syphilis and the specific fevers, and others were due to toxins similarly brought. But for the most part the cause of the skin condition was the cause of the bodily disorder; the rash of measles, for example, was due to the micro-organism which caused measles, and not to the disease itself.

Dr. J. M. H. MACLEOD thought that the help of the physiological chemist would have to be enlisted more and more in endeavouring to trace these subtle foreign proteins or antibodies that were responsible for one or other toxic rash. It seemed to him that just as the skin was an important and essential organ of the body, linked up directly or indirectly in its perfect function with every other organ, so any diseased condition of any other organ, if it went on long enough, was liable to be associated with a disorder of the skin; and, on the other hand, any diseased condition of the skin, however local its etiology, was liable to be influenced more or less profoundly by the general internal state.

Dr. H. MACCORMAC said that it was not always realized that even local skin affections might also depend upon some general condition. Even in ringworm of the hair of the scalp, the process died out spontaneously at puberty, so that there was evidence of some change in the tissues caused by some condition of which they could have no microscopic or other evidence. He referred also to a vitamine-deficiency disease from which the Eskimos suffered during the absence of fresh seal meat from their diet; it consisted of an eruption in various parts of the body, pustular in type, and very irritating, but disappearing when the food supply became normal. There one got a pustular infection of the skin which could only arise from a profound change in the tissues.

Sir F. W. MORT, in closing the meeting, said that the question of anaphylaxis was one on which he would have liked to have spoken, but for the lateness of the hour. The French looked upon this phenomenon as "a dislocation of the static equilibrium of the colloids."

TREATMENT BY X RAYS AND RADIUM.

At a meeting of the Edinburgh Medico-Chirurgical Society on February 2nd, Emeritus Professor F. M. CAIRD presiding, Dr. R. KNOX (London) opened a discussion on treatment by x rays and radium. After dealing with physical data, the technique of application, the measurement of doses, etc., he discussed the results of radiation treatment in clinical conditions. Superficial lesions of the skin were the earliest to be treated, and remained still the most favourable in results. It was the best treatment for tinea capitis, though permanent baldness resulted in a few cases. In rodent ulcer radium was better than x rays, which perhaps explained the lesser frequency of relapse in later cases. Most of the early cases did well at first, but sooner or later relapsed, and then resisted radiation. Lupus vulgaris sometimes gave good results, but here regulation of doses was necessary to avoid the real danger of lupous carcinoma. Hyperidrosis was readily controlled. The blood and body fluids were profoundly affected by radium and x rays. In leukaemia the immediate effect was striking, in reduction of the spleen and of the leucocyte count; but though the disease might be controlled for years, the final result was nearly always relapse. In this disease, as in Banti's disease, radium was better than x rays. In exophthalmic goitre radium should be given at the bedside, but combined with rest and

drugs. In conditions of lymphatic glands, simple inflammation and lymphadenoma rapidly responded; so also sarcoma, but with later relapse; with tubercle and carcinoma the response was slow. In fibromyomata of the uterus the tumours never disappeared; they were often reduced by a third or a half, and even where the reduction was not appreciable there might be great improvement in health from the cessation of haemorrhage and from effects upon ovaries and blood. A proportion of these cases were not benefited by radiation treatment. In carcinoma of the breast he advised a preliminary radiation before operation, and after it thorough treatment of the operation and drainage areas. Some of the cases of early recurrence were also amenable, while certain inoperable cases after x-ray treatment became operable. Other benefits in bad cases were the healing of ulcerated areas and the relief of pain. In uterine cancer a combination of local radium treatment and of x rays applied externally was advised. He concluded by forecasting an early improvement in technique, enabling x rays of greater penetrative power to be used, and by pleading for closer co-operation between the clinician and the radiologist.

Professor ALEXIS THOMSON gave some personal experiences with radium in malignant tumours. It could not be trusted alone, and even when there was an apparent disappearance of the tumour he advised operation. Also relapsing tumours seemed to be immune to radium action. A good rule was in operable tumours to operate and insert radium, and in inoperable tumours to attempt to render them operable by radium. Of the sarcomata, the lymphosarcoma was most amenable to treatment. Dr. CRANSTON Low said that x rays had revolutionized the treatment of ringworm; only 1 per cent. of the cases developed permanent alopecia; by its means ringworm epidemics could be controlled, while in Edinburgh favus had been reduced to sporadic occurrence. With rodent ulcer, radium was better than x rays, and the aim was to give the maximum dose in the shortest time that the skin could stand. In lupus the administration of x rays must be done with care so as to avoid overstimulation of the tissues and the production of a lupous carcinoma. Professor GULLAND said that in myelogenous leukaemia his later results with radium were better than with x rays. There was danger that excessive dosage might produce pernicious anaemia, and he advised that the reduction of leucocytes should not be carried below 20,000 per cubic millimetre, as reduction continued for some weeks after the last treatment. The same caution was necessary in exophthalmic goitre, where also radium was superior to x rays. In Banti's disease, though great reduction in the spleen took place, there was no absolute cure by radium, and splenectomy was necessary.

Professor Sir HAROLD STILES said that he preferred radium to operation in lymphadenoma. In cancer of the rectum and colon he advised that if there was any doubt as to complete removal, radium should be left at the site of operation. There was need of experimental investigation of radium, and of more precise knowledge of its action upon living tissue and of its dosage. Dr. HOPE FOWLER pointed out that radium treatment was particularly suited for those damaged by x rays. There was need of careful regular blood examination in irradiated patients. Lymphatic tissues were more amenable to radiation than epithelial.

Dr. NORMAN WALKER thought that Dr. Knox had been too pessimistic about the x-ray treatment of ringworm. There was no doubt that lupous carcinoma had greatly increased since the use of x rays, and that this treatment carried a serious risk of this complication. Mycosis fungoides showed great benefit under x-ray treatment. Indiscriminate x-ray treatment for superfluous hair in women often produced bad end-results in atrophy of the skin and lymphangiectasis. Dr. LOGAN TURNER said there was need of apparatus that would allow of the application of radiation to growths in concealed cavities such as the larynx. Mr. D. GREIG spoke of the failures of this treatment, and cited cases of mycosis fungoides as instances. He deprecated undue optimism.

PROFESSOR RÖNTGEN has been elected a doctor *honoris causa* by the Frankfurt Faculty of Natural Science.

PROFESSOR HUTINEL, who recently resigned his professorship of children's diseases in the University of Paris, has been succeeded by Dr. P. Nobécourt.

Reviews.

INSTINCT AND THE UNCONSCIOUS.

IN *Instinct and the Unconscious*,¹ by Dr. W. H. R. RIVERS, the psychologist and psycho-pathologist will find a work which well repays the most careful study. It opens up new lines of thought, and may be said to meet a definite need. During the last few years remarkable advances have been made in psychology, and the progress which has taken place is in a large measure due to the contributions made by the psycho-pathologist in daily contact with the practical problems of the clinic. The time would now seem to have come, however, when the dogmas, theories, concepts, and terminology of clinical psychology should be subjected to the closest scrutiny. The whole subject needs to be hardened and clarified; it needs constructive criticism, wider view-points, and minute and careful observations. Especially must the endeavour be made to interpret abnormal reactions in terms applicable to the organism as a whole. The facts of clinical psychology need to be harmonized with the whole body of biological and physiological knowledge and to be expressed in the special language of science, because it is only in this way that psycho-pathology can be extricated from the narrow circle of repetitions into which it would seem to be in danger of falling. Such an aim is most likely to be achieved, not by the clinician, who is naturally largely preoccupied by therapeutic considerations, but by the trained psychologist and scientific observer who is in a position to interpret facts with more detachment and with a wider range of knowledge. It is from this wider outlook that Dr. Rivers approaches the problems of mental functioning, and his book may be regarded as a contribution of definite value, and as a real addition to our knowledge of the subject with which it deals.

The expressed aim of the book is to develop a biological view of the psycho-neuroses, and the endeavour is made to bring functional disturbances of the mind and nervous system into relation with the concepts concerning their normal modes of working which are held by the biologist and physiologist. Dr. Rivers sets himself more particularly to consider the general biological function of the process by which experience passes into the region of the unconscious. This process he calls *suppression*, and he takes the view that this process occurs—especially as the result of physical and mental shock—without the intervention of volition, and that it is to be regarded as an active and especially complete form of forgetting. He limits the content of the unconscious to experiences of this kind which are not capable of being brought into the field of consciousness by the ordinary processes of memory or association. The relation between suppression of psychological experiences and certain physiological phenomena is next considered, and it is shown by reference to the work of Head, Rivers and Sherren in respect to protopathic and epicritic sensibility that in the former mode of eutaneous sensibility we find evidence of suppression at the physiological level analogous to that which occurs at the psychological level. The argument is thus developed that suppression of conscious experience is only one example of a process which applies throughout the whole of the animal kingdom, and is essential to the proper regulation of every form of human and animal activity. Every living process of the animal involves, not only activity directed to a special end, but also the inhibition of tendencies to activities of other kinds. Thus suppression is to be regarded as only one aspect of the universal physiological property of inhibition.

In chapters on "The content of the unconscious," "The nature of instinct," "The danger instincts," "Suppression and the all-or-none principle," and "Instinct and suppression," Dr. Rivers develops smoothly and consistently his central contention that the same biological principles are operative at the psychological levels of development as at the sensori-motor and reflex levels of activity. The treatment of these subjects is most suggestive and full of interest. As an example may be cited a subject upon which Dr.

Rivers lays particular emphasis, namely, the protective reaction to danger by means of immobility. In suggesting that hysterical symptoms—paralyses, mutism, anaesthesias—are modified forms of this instinct he has undoubtedly brought into prominence a point of view of considerable significance, and one which might be utilized for the elucidation of other forms of abnormal reactions. His views would seem to be particularly applicable to the negativistic behaviour which is such a prominent feature in cases of dementia praecox. The thought suggests itself that we here find a much purer form of the instinct of immobility than that found in the hysteric. This is to be expected, as the reactions in dementia praecox are extremely primitive in character and expressive of a much deeper stage of regression than are those of hysteria. In the "death feint" the threatened animal can be pushed about and rolled over without any apparent response—a state of affairs which is almost paralleled in the postures, tensions, and attitudes of many katatonic cases. The negativism in dementia praecox may thus be regarded as a biological protective reaction which guards the patient, not from physical danger, as in the case of the immobile animal, but from undesired intrusions into his inner mental life.

In subsequent chapters Dr. Rivers deals with "dis-sociation," "the complex," "suggestion," "hypnotism," "sleep," "hysteria," "sublimation," and "regression." It is, of course, outside the scope of a review to discuss his treatment of these subjects, but some brief reference may perhaps be made to the views which Dr. Rivers has formulated in regard to Freud's psychology. His attitude is developed more fully in the appendix to this volume, which contains two articles entitled respectively "Freud's psychology of the unconscious" and "Freud's conception of the *castration*." There is no doubt a very large measure of truth in Dr. Rivers's view that Freud's theories have been pushed by their advocates beyond the position they are entitled to hold, with the result that, failing to fulfil the expectations thus aroused, their merits may be underestimated, or even be in danger of being thrust into the limbo reserved for dead hypotheses, only to be rescued therefrom by some later generation. He is probably correct, moreover, in suggesting that the excessive absorption in the sexual determinants of human reactions which characterizes the followers of Freud is to a large extent a reaction from the timidity and prudery of the past in relation to sexual matters, and is a protest against the ignorance of this side of life which often exists. One outstanding merit of Freud's psychology, as Dr. Rivers recognizes, is the emphasis he has laid on the fact that human reactions, both normal and morbid, are determined by the totality of the individual experience as well as that of the ancestral or racial experience; not only has he recognized this fact, but he has devised methods which, when judiciously used, are of considerable practical utility, for by means of them the historical past of the individual may be brought to light.

As indicated above, Dr. Rivers devotes considerable attention to the vexed question of the censor—a concept which bulks so largely in Freud's psychology. This concept of an anthropomorphic entity, itself unconscious, standing between the true unconscious and preconscious, is artificial and obviously needs further examination. Dr. Rivers contends that a concept which is based on analogy with a highly complex and specialized institution should be capable of being expressed in some other and more satisfying form. He maintains that it is to physiology rather than sociology that we should look for the clue to the nature of the process by which a person is guarded from the intrusion of disturbing elements of his unconscious experience and he proceeds to develop a view which harmonizes with the biological principles maintained throughout the book. Assuming the organization in the unconscious of a functional hierarchy such as exists in the nervous system, he goes on to show in regard to dreams that the relaxation of conscious control in sleep must result in the emergence of mental activities identical in form and structure with the thoughts, feelings, and conduct peculiar to the infantile stage of mental development. This is not the place to either epitomize or discuss the views which Dr. Rivers brings forward. It may be said, however, that they are highly suggestive and appear to afford a better explanation of the effortless mental activity

¹*Instinct and the Unconscious. A Contribution to a Biological Theory of the Psycho-neuroses.* By W. H. R. Rivers, M.D., D.Sc., LL.D., F.R.S. Cambridge: University Press, 1923. (Demy 8vo, pp. 260, 16s. net.)

which may be assumed to accompany the repose of the psycho-physical organism during sleep, than does the concept of the censorship with its suggestion of strain, vigilance, and tension.

In addition to the papers above mentioned, the appendix contains reprints of several articles by Dr. Rivers relevant to the subjects dealt with in the first part of the book. We notice a rather unusual number of mistakes in printing, and the first sentence on page 232 is in a particularly unhappy condition.

Dr. Rivers has written a most interesting book, and one which we can unreservedly recommend to our readers.

THE MEDICAL TREATMENT OF EXOPHTHALMIC GOITRE.

IN *Exophthalmic Goitre and Its Non-Surgical Treatment* Dr. ISRAEL BRAM,² who is instructor in clinical medicine under Professor Solomon Solis-Cohen at the Jefferson Medical College, Philadelphia, insists with no uncertain voice that operative treatment of the thyroid is futile in primary hyperplastic goitre of Graves's disease, and that nearly every such case, if not moribund, is curable by non-surgical means of one kind or another. While condemning operations on the thyroid in primary exophthalmic goitre Dr. Bram frankly admits that removal of nasal polypi, adenoids and diseased tonsils, a chronically inflamed "controlling" appendix, or an affected portion of the female pelvic organs, may cure hyperthyroidism; and further he approves operation on a simple non-toxic goitre of some standing on which symptoms of Graves's disease have recently been superimposed. After a full account of the various opinions held as to the pathogenesis, and after numerous quotations from McCarrison, Crile, and others, the conclusion is reached that both simple and toxic goitres depend upon factors outside the thyroid. The analogy of appendectomy which has been urged in favour of thyroidectomy in Graves's disease does not hold good; for appendicitis is a local disease which reflexly produces symptoms, whereas exophthalmic goitre is secondary in etiology.

As the possible causes and manifestations of the disease are numerous, it is not surprising that many remedies sometimes act beneficially; thus most patients are made worse by iodine, but occasionally its administration has brilliant results; some patients improve on an ample beef diet, whereas others react favourably to vegetarianism. The important section on prophylaxis gives the details of Marine and Kimball's extensive and successful experience in the prevention of goitre by sodium iodide given to 1,000 schoolgirls in the Great Lakes goitrous area. In the account of the hygienic treatment of the disease the importance of removing any possible causal factor is emphasized, and then, in connexion with the subject of rest, it is pointed out that in the average case "a rest cure rests neither body or mind," and that accordingly complete rest in bed is contraindicated, except in dangerous cardiac insufficiency. The dietetic treatment is carefully discussed, the objections to a meat regimen are mentioned, and a number of diet sheets are given. Medicinally quinine, especially the hypobromate (gr. v, t.d.s.), is the drug of choice. In the shrewd and practical remarks on psycho-therapy attention is drawn to the value of making the patient laugh, and to the therapeutic use of music, according to the patient's taste; thus, "even jazz, the prototype of cubism in art," may be beneficial. Although the psycho-therapeutic measures necessary may impose a difficult task on the medical attendant, the results fully compensate for the pains expended. Written in a rather breezy style, this monograph may perhaps arouse criticism, but it shows practical wisdom combined with a good acquaintance with the literature of a subject much to the fore in the United States.

AMERICAN MEDICAL BIOGRAPHIES.

American Medical Biographies, by Professor HOWARD A. KELLY and Dr. W. L. BURRAGE,³ is the expansion of the

² *Exophthalmic Goitre and Its Non-Surgical Treatment*. By Israel Bram, M.D. London: Henry Kimpton. 1921. (Med. 8vo, pp. 438, 20s. net.)

³ *American Medical Biographies*. By Howard A. Kelly, M.D., LL.D., F.A.C.S., Hon. F.R.C.S. (Edin.), and Walter L. Burrage, A.M., M.D. Baltimore: The Norman Rennington Company. 1920. (Double crown 5to, pp. 1359.)

biographical part of Professor Howard Kelly's *Cyclopaedia of American Medical Biography*, which was published in 1912, and contained introductory chapters on the history of several of the specialties, a number of portraits, and 1,184 biographies. The present volume contains 1,948 biographies, and thus provides succinct information about the medical worthies of the United States of America and Canada for more than 300 years, ending with the year 1918. The principle of selection has been to include every man or woman who has in any way contributed to the advance of medicine in the United States or Canada, or who, being medically qualified, has become distinguished in general science or in literature. The list contains stars of the first, second and third magnitude, and naturally the question of admission often arose; in coming to a decision the editors "cultivated a catholicity of judgement that broadened as the work progressed." In addition to a general alphabetical index, there is a local index in which an attempt has been made to give the chief places of practice of the worthies in this book alphabetically by states, territories, and the provinces of Canada. The first name in the first state, Alabama, in the local list is that of J. Y. Bassett, made so familiar as "An Alabama Student," by the late Sir William Osler, who contributed this and other biographies to this work. The State of Utah and Prince Edward's Island each have two names to their credit, New York nearly 500, Pennsylvania over 300, and Massachusetts about 250. The bibliographies resemble those in the *Dictionary of National Biography*, and, though not all signed, are by various hands; one of the longest, that on Benjamin Rush, "the American Sydenham," occupying about seven columns, is by Dr. F. R. Packard, and one of the most charming is Professor Howard Kelly's account of Colonel John McCrae, the author of "In Flanders Fields." Most appropriately the work is "dedicated in love and esteem to the memory of Sir William Osler," whose lifelong interest in the subject did so much for medical biography and its study in America. The labours of Professor Howard Kelly and Dr. Burrage have been crowned by success, for they have provided a source of reference from which many will draw for many years, and on all accounts they deserve our sincere thanks and congratulations.

NOTES ON BOOKS.

THE second edition of *Diseases of the Chest*,⁴ by Professors LANDIS, NORRIS and KRUMBHAAR, of the University of Pennsylvania, provides the student and medical practitioner with an excellent work on the principles and practice of the physical diagnosis of diseases of the chest. The first edition of this book was reviewed less than four years ago (BRITISH MEDICAL JOURNAL, 1917, ii, 796), and it suffices to say that the present edition has been well brought up to date and amplified where necessary. The volume contains a great deal of valuable information as to the how and the why of the physical signs upon which diagnosis so largely rests, and should be within reach of all medical students.

VOLUME XIV of a *Traité de Pathologie Médicale et de Thérapeutique appliquée*,⁵ published under the direction of EMILE SERGENT, L. RIBADEAU-DUMAS, and L. BABONNEIX, deals with parasitic infections. Several authors—Neveu-Lemaire, Aménille, Troisième, Paiseau, Gouzien, Abrami, and Raymond—contribute to it. The part will appeal to tropical workers, as helminthiasis, protozoology, and other tropical diseases appear in its pages. Neveu-Lemaire deals with coccidiosis, and the new work by Dobell on this subject is incorporated. The helminthic chapters give a very good account of the subject, on the whole, though perhaps there is nothing very new to report. Trypanosomiasis, malaria, leishmaniasis, dysentery, spirochaetosis, rat-bite disease, are some of the other subjects dealt with. The volume with index runs to 577 pages. The illustrations are somewhat scanty, but those that do appear are quite good and instructive. The coloured plate on malaria

⁴ *Diseases of the Chest and the Principles of Physical Diagnosis*. By George William Norris, A.B., M.D., and Henry R. M. Landis, A.B., M.D. With a chapter on the Electrocardiograph in Heart Disease, by Edward B. Krumbhaar, Ph.D., M.D. Second edition, revised. Philadelphia and London: W. B. Saunders Co. 1920. (Roy. 8vo, pp. 844; 433 figures, 35s. net.)

⁵ *Traité de Pathologie Médicale et de Thérapeutique appliquée*. Publié sous la direction de Emile Sergent, L. Ribadeau-Dumas et L. Babonneix. XIV: Infections Parasitaires. Par Neveu-Lemaire, Aménille, J. Troisième, Paiseau, Gouzien, Abrami, et Raymond. Paris: A. Maloine et Fils. 1921. (Demy 8vo, pp. 577; 145 figures, 2 plates. Fr. 30; post free, Fr. 33.)

is not very good: it might have been better for a book of this kind. The descriptions of the diseases are full and up to date, and the book may be recommended to those who read French.

A COMPENDIOUS but expensive students' handbook of treatment is provided by Professor FINKELNBURG of Bonn, aided by a dozen contributors, in the form of *Therapy at Bonn University Clinique*.⁶ The first five hundred pages deal with medicine and surgery; the remainder is devoted to gynaecology, cutaneous diseases, and special forms of treatment. It is doubtful whether the whole subject of treatment is capable of compression within the narrow limits of a book of this size, if practical utility is to be considered and if generalities, useless to the beginner, are not to take the place of the detailed advice for which he is always seeking.

⁶ *Die Therapie an den Bonner Universitätskluiken*. By Professor Dr. Rudolf Finkelburg, in Bonn. Dritte, vermehrte Auflage. Bonn: A. Marcus and E. Webers. 1920. (Cr. 8vo, pp. 757; 7 figures. M. 36; bound M. 44 40.)

APPLIANCES AND PREPARATIONS.

A Double Retinoscope.

DR. R. C. MACDONALD (Inverness) writes: With the double retinoscope here illustrated refraction is more easily and more accurately performed, the shadows are more vivid, and the illumination better than with any single instrument, and the operator has the benefit of vision with both eyes, and if he is ametropic can wear his correction. Correction can be made

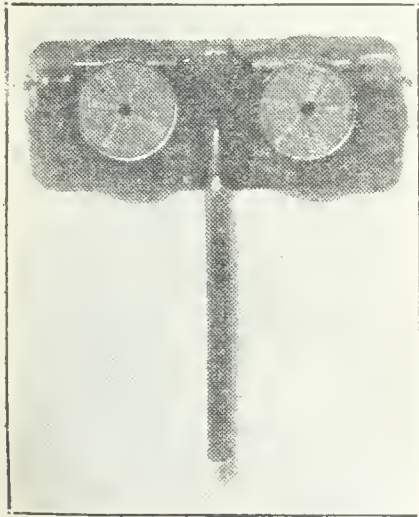

to an eighth of a dioptré or less, and good results can be obtained even in daylight. An ordinary bullseye electric, argand, or other lamp is used over the patient's head in the usual way. The instrument must first be adjusted to the interpupillary distance of the operator; then the reflection is thrown on a screen at the working distance preferred—say one metre—and the two reflections are accurately superimposed so as to make one circle of light. On looking through the in-

strument, at the eye a brilliant reflex is seen by both eyes simultaneously. No further adjustments are required unless another operator wishes to use the instrument. An electric model is also made, and the instrument can be obtained with concave or plain mirrors according to choice. The instrument is made for me by Mr. Robert Whitelaw, surgical instrument maker, Woolmanhill, Aberdeen.

Mentho-fax Ointment.

Methyl salicylate, which is rapidly absorbed when rubbed into the skin, is often employed as a local application in chronic rheumatism and neuralgic affections. Messrs. Burroughs, Wellcome and Co. now prepare a compound methyl salicylate ointment to which they have given the name "mentho-fax." This contains—in addition to some 50 per cent. methyl salicylate—menthol, eucalyptol, and oil of eajuput. It is packed in collapsible screw-topped tubes for use when an analgesic and rubefacient application is needed.

MESSRS. J. AND A. CHURCHILL announce for early publication *Critical Microscopy*, by Dr. A. C. Coles.

We have received from the Disabled Society a pamphlet compiled by Captain H. C. Baird, D.S.O., "for the general guidance of ex-service men of all ranks who have lost one or more arms or legs." Its fourteen pages contain a good deal of information which should be useful to persons who have undergone amputation as to rates of pension and other benefits to be obtained by disabled ex-service men. We fear that it may be too late to protest against the absurd but widespread practice of describing a man who has perhaps three and three-quarter limbs instead of four as "limbless."

THE SEARCH FOR A SPECIFIC TREATMENT OF TUBERCULOSIS.

A BACTERIOLOGIST'S ATTEMPT.

ATTENTION has recently been called in the public press to a specific method for the treatment of pulmonary tuberculosis devised by Henry Spahlinger, a Swiss bacteriologist. Professor Letulle communicated to the Académie de Médecine on April 28th, 1914, a note in which it was stated that the method consisted of a series of intramuscular injections of a combination of tuberculous antigens and of ferments, and that this "specific" treatment was combined with an "auxiliary" treatment composed of ferments associated with lipoids, which were administered either intramuscularly or intravenously. A considerable number of cases were, we believe, treated at the City of London Hospital for Diseases of the Chest and possibly elsewhere in London at that time, and it appears that some of them survive; how many were treated and how many survive we have not been informed. We have received from Dr. A. H. Croucher of Eastbourne a letter, dated February 14th, transmitting a translation of a note which he informs us was deposited by M. d'Arsonval at the Académie des Sciences in Paris on February 7th. In this note it is stated that the material used consists of antigens and ferments obtained from the tubercle bacilli. The antigens, it is stated, are separately inoculated in increasing doses, according to a fixed scale, so that at the end of several months an injection of all the components of the bacillary bodies is made. The note goes on to say that treatment by this method has been carried on from 1915 to the present time in Switzerland, France, and England; Dr. Croucher reports that all the cases known to him treated six years ago were still alive and capable of carrying on their daily occupations at the end of 1920. All the patients, he states, were in 1913 suffering from advanced tuberculosis and two had laryngeal complications. The note contains also a statement by Dr. Leonard Williams, who is represented as stating that certain cases of advanced tuberculosis with bacilli in the sputum treated under his observation by this method in 1912-14 had remained well during the last six years, although they had received no specific antituberculous treatment since 1914. Examination in 1920 showed that their condition was good; there was no trace of active tuberculosis, no cough, and no expectoration.

The statement that the Ministry of Health had sent one of its staff to Geneva to investigate the matter is incorrect, and it is, of course, clear that no useful purpose could be served by such a mission until M. Spahlinger and his friends have made a full statement as to the way in which the material is prepared and have allowed competent bacteriologists to observe their methods. As Dr. Addison said very judiciously at Exeter, "it is most important, having in view the fact that widely published statements may raise unfounded hopes in the hearts of consumptives, that it should be stated as clearly as possible that in the case of this supposed remedy much further investigation will be necessary."

The reports which have so far reached us do not make plain the real nature of Spahlinger's remedy. In the following communication, which we have received from Dr. W. Camac Wilkinson, he assumes it to be in the nature of a tuberculin:

I have read the evidence in favour of the method advocated by the Swiss bacteriologist, M. Henri Spahlinger, and have frankly discussed his point of view with him at a private interview. His method is based on the principle of active immunization by means of the products of the specific tubercle bacillus, and his remedy is therefore specific. He even speaks of antigenic treatment, using the very term I suggested years ago instead of the irrelevant term "vaccination" or treatment by "vaccines." Tuberculin is the antigenic substance and is not a vaccine.

In fact and in principle, M. Spahlinger's method is the self-same method which I have been using for thirty years, and have been advocating in season and out of season for twenty years. M. Spahlinger even has the same views upon "mixed infection" which I have unceasingly championed since the year 1896. Moreover, I can produce at least five times as many cases as M. Spahlinger can, which were treated in 1910, 1911, and 1912, and are still alive and at work in 1921. I therefore view

M. Spahlinger's method in no hostile spirit; indeed, I welcome him as an ally. Our methods are similar, and may be the same. Possibly M. Spahlinger has improved the means of securing immunity by using the products of the tubercle bacillus in a somewhat different and better way or in a modified form.

I must approve of the direct method of treatment that exploits the products of the tubercle bacillus as a means of creating immunity against the live bacillus, and I have abundant evidence that, with care, discrimination, experience, and courage, one can slowly build up a fairly efficient mechanism of immunity—even in advanced forms of pulmonary tuberculosis complicated with tuberculous ulceration of the larynx—by means of these very products. The direct examination of the larynx, of the blood by Arneith's method, and of the expectoration, yields convincing evidence of the value of this method of active immunization by means of the specific products of the tubercle bacillus. If one can obtain these results in the late stages, *a fortiori* the treatment of the early stages must be and is tenfold more successful.

It was to prove the value of these specific products, which, variously modified, I had used in Australia for twenty years with great success, that I came to England in 1909, and established my tuberculin dispensary and its branches; and at the present moment there is no better place for testing the relative merits of my methods and M. Spahlinger's. When I came to England, tuberculin as a remedy for tuberculosis had been abandoned (see Osler's *Medicine*). If I have done nothing else I have made medical men think hard and talk loud of the dangers of tuberculin, till year by year the talk about danger has subsided into a timid whisper; the latest book on tuberculin treatment does not even mention danger. The medical profession may now be in a mood to give a fair and open trial to specific treatment. My work has prepared the way, and I rejoice to think that a Swiss bacteriologist gives this stimulus to research, for which I have been pleading for many years. I personally welcome any fair and open trial of any method of specific treatment, which is most surely the method of the future. But it must be a real trial of the relative merits of our systems by competent judges who have made themselves authorities by work and not by official position.

Such a trial must fulfil strict conditions. Assuming that the trial will be in the hands of experts, I have already laid down the essential conditions in my work published in 1912:

1. The remedy should be the only remedy used in treatment.
2. The remedy should be exploited in a consecutive series of cases of all kinds (not merely specially selected cases), and all the cases fully treated should be published.
3. After treatment the cases should be carefully watched and examined for at least three or four years before a final judgement is given upon the value of the remedy.
4. The results should be arranged in three groups, or better, as in my own records, in five groups, according to the character and degree of the changes in the lungs.

These conditions, I admit, disqualify the work of almost all observers, because, except by myself, tuberculin has never been tested under these conditions. My own observations have been carried out as far as possible under these conditions, and therefore should furnish trustworthy evidence of the value of the method. (*Tuberculin in the Diagnosis and Treatment of Tuberculosis*, p. 477.)—I am, etc.,

W. CAMAC WILKINSON, M.D.Lond., F.R.C.P.,
Director, Tuberculin Dispensary.

THE ADVANCE OF MEDICAL EDUCATION IN CHINA.

A MEETING of members of the medical profession to advance the cause of medical education in China was held in the Barnes Hall of the Royal Society of Medicine on February 21st. Sir DONALD MACALISTER presided over a large gathering, and messages of regret at inability to attend were received from the late and present Chinese Ambassadors, the American Ambassador, and others.

Sir DONALD MACALISTER said that for many years he had been associated with Christian propaganda in China, in particular with medical missions. It had long been his conviction that the true method of spreading Christianity in the East was the method of its Founder, who went about not only preaching the good news of the kingdom,

but healing all manner of diseases. But when the seeds of Christianity had been wisely planted in China its further growth would be conditioned by the measure in which it ceased to be regarded as foreign. The ultimate aim of medical missions in China should be, not to place numbers of British or American doctors all over that land, but by education to build up a Chinese medical profession. That was the spirit of the great educational enterprises centred at Moukden and Peking, and very particularly at the Christian University of Shantung.

Mr. HAROLD BALME, F.R.C.S., of the School of Medicine of the Shantung University, said that western medicine was introduced into China by Colledge, a surgeon of the East India Company, in 1827, and a little later by Parker, a medical missionary from America. The first Chinese medical college was established at Tientsin in 1881, thanks to Kenneth Mackenzie of the London Missionary Society, and the help of Li Hung Chang. Six years later a second medical school for Chinese students was founded in Hong Kong. After the Boxer rising a school of medicine was established in Peking, the result of a combined effort of British and American medical men, and, following this, missionary medical colleges sprang up in other parts of the country—too many of them, indeed, in view of the limited staffs and equipments available. Meanwhile, a body of Chinese medical men, who had received their training in England and America, formed a National Medical Association, with Dr. Wu Lien-teli, a graduate of Cambridge, as leader. Other organizations, not specifically missionary, in America, Germany, and Japan took a share in the work of medical education, especially the Rockefeller Foundation, which took over the complete financial responsibility of the Peking College, to which a large staff of expert teachers had been appointed, mostly from the United States, but including thirteen Chinese professors. The Council of Medical Education of the China Medical Missionary Association had asked the Rockefeller Foundation to assist in the support of at least one medical school teaching in Chinese, and had also urged that all missions interested in the advance of medical education in East and Central China should concentrate their forces upon the development of such a school. The school chosen was the one at Tsinan, now the school of medicine of the University of Shantung. The Rockefeller Foundation had asked the school to take over the three junior classes formerly under instruction at the medical college in Peking, and had made a very generous grant towards staffing, building, and equipment. The school had secured a faculty of over twenty full-time teachers, representing some of the leading British and American universities. Similar efforts were being made in Moukden, Chengtu, Shanghai, and other places. The Council of Medical Education had also outlined a two-year course of pre-medical instruction to be taken by students previous to entering upon their five-year medical course. The speaker touched also upon the great improvements in the Chinese nursing service, the interest of the modern Chinese in preventive medicine, and the sympathetic attitude of the Chinese Government. The policy of the Board of Education of China, as stated by a representative of the Board at the last conference of the China Medical Missionary Association, included the provision of a modern medical college in each province, the opening of an institute for research, and the registration of general practitioners.

Sir A. PEARCE GOULD moved:

That having heard with pleasure of the sympathetic interest of the Chinese Government in the development of modern medicine in China, and of the steps which have already been taken by British and American medical practitioners to co-operate with the Chinese in the establishment of medical schools in which the highest standards are set, this meeting of members of the British medical profession desires to place on record an expression of its sympathy with this effort, and its willingness to promote in every way possible the advance of medical education in China.

He remarked on the ancient civilization of China, that at a period when we in Europe were without measure of time or a craft to our fingers, the Chinese were expert astronomers and proficient in the fine arts. It was unthinkable that a people who had been so great in the past and still had such wonderful powers of grasping modern science—as was proved by the work on plague prevention

carried out by Chinese graduates—should not carry the lamp far ahead once it was placed in their hands.

Mr. McADAM ECCLES, in seconding the resolution, said that he believed that medical education in China would result in diminishing, if not abolishing, what was called the "Yellow peril."

The resolution was carried unanimously.

Dr. H. G. EARLE, Dean of the Medical Faculty of Hong Kong University, expressed his appreciation of the work of the China Medical Missionary Association. Last year he attended its biennial conference, which was split up into scientific sections, where a great deal of original research was brought forward. In Hong Kong all the special buildings for medical work—physiology, anatomy, tropical medicine—were the result of donations from the Chinese community. He always told his students who wanted to visit England or America to qualify in their own country first, and the provision of post-graduate facilities here for Chinese graduates would to no small extent advance medical education in China.

Dr. L. SAMBON suggested that not only should the results of Western research be carried to China, but that we in the West should study the ancient medical knowledge of China and of the Orient generally. China first taught the treatment of syphilis by mercurial preparations, and we owed the prevention of small-pox in some degree to China, though more to India.

Mrs. SCHARLIEB proposed a vote of thanks to the Chairman; and Sir JOHN JORDAN, late Minister Plenipotentiary to Peking, in seconding, said that although the British were the pioneers of medical work in China, and for a long period carried it on alone, they had now yielded to the Americans in this respect, greatly to the loss of British influence and prestige. The best intellect of China was now being trained in the United States, where in a single city there were gathered more Chinese students than in the whole of this country.

LUNCHEON TO THE EDITOR OF THE "BRITISH MEDICAL JOURNAL."

SIR DAWSON WILLIAMS, Editor of the BRITISH MEDICAL JOURNAL, was entertained by the Council of the British Medical Association at a complimentary luncheon at the Hotel Cecil on Wednesday, February 16th, in recognition of the knighthood conferred upon him at the New Year by the King. Dr. R. A. BOLAM, O.B.E., Chairman of Council, presided. The toast of the King having been duly honoured, the Chairman referred to Sir Dawson Williams's long connexion with the BRITISH MEDICAL JOURNAL, and to his appointment as Editor in 1898. He was sure that they were all deeply glad that Sir Dawson Williams's work for the Association, for the profession of medicine, and for the community at large, had been recognized in the way it had been by His Majesty the King. Sir Dawson Williams had always been willing to give every assistance and advice in his power, and though some of them had not always found his opinion the same as their own, they knew that the view expressed was given honestly and without fear.

Sir CLIFFORD ALBUTT, President of the Association, referred to his long friendship with Sir Dawson Williams and to the many accomplishments of their guest. He said that if one tried to put into a word, or into a few words, the character Sir Dawson Williams set before them, he thought they would feel that that combination of breadth of view and sympathy, and a fine kind of understanding and knowledge of the world, was summed up in the single word, wisdom—he was a particularly wise man. Another quality was his impenetrable modesty. His presence at the head of what was the greatest medical journal in the British Islands had been of very great benefit to the affairs of the British Medical Association, and had helped to bring it to the high position it now held. The Editor was from time to time called upon to deal at once with matters affecting the profession which were suddenly raised and were afterwards the subject of full consideration and discussion. He had always been astonished at the skill with which the Editor had dealt with such matters when first arising.

Dr. J. A. MACDONALD said he wished to add his quota to the appreciation of Sir Dawson Williams, because probably he had had more intimate intercourse with him than anyone else in the assembly during the twenty years for which he had been closely connected with the work of the Association; he would like to add something to what Sir Clifford Albutt had said of their guest's public career by which he had made his name. From all he had heard, particularly from those who attended the special meeting of the Association in London in 1919, the appreciation of Sir Dawson Williams was world-wide. Every man with whom he had spoken in that great assembly of the medical profession referred to Sir Dawson Williams's wonderful prescience, and his way of getting at the heart of things and giving a good sound opinion. With regard to the JOURNAL, it had taken the head place of medical journalism in the world. He had consulted Sir Dawson Williams on many occasions, and his opinion, once obtained, was invaluable. There was no man in the whole of the medical profession whose opinion and knowledge of affairs was so much appreciated as that of their guest, but it was often difficult to get.

The CHAIRMAN then formally proposed the health of Sir Dawson Williams, which was received with musical honours.

SIR DAWSON WILLIAMS, who on rising was received with acclamation, thanked those present for the reception accorded him. The fact that the honour of knighthood had been conferred upon the Editor of the *Lancet* showed that the desire was that the work done by the medical journals in connexion with the war should be officially recognized. That being so, he was of course pleased that the JOURNAL of the Association was included in the recognition. The war brought about a position of gradually increasing difficulty for medical journalism. It entailed, among other things, a change in the scope of the JOURNAL, as probably two-thirds of the active medical profession were engaged in military surgery and medicine. If he was right in believing that the honour conferred upon him was due to action taken by influential members of the general press, it was interesting to remember that the general press was founded some three hundred years ago by a doctor of medicine. During his long connexion with the JOURNAL, and especially during the twenty-three years he had been Editor, he had seen great and beneficial changes in its character; he hoped the progress might continue. The JOURNAL had two main functions to discharge. First, the dissemination to members of the Association of information on the progress of clinical medicine and the sciences on which it rested; and that, in his view, was by far the most important duty, for the very practical reason that as the profession became more efficient in the prevention and cure of disease, so its influence in Parliament and in the general community would increase, and further, in this way only would quackery be extinguished. The other important work was to disseminate information as to what was being done by the Association in connexion with medico-political affairs. He had always received the greatest kindness and consideration from all the officers of the Association, and especially from Dr. Macdonald during all the trying time he was Chairman of Council until his recent retirement.

The following letter was addressed to the Editor of the JOURNAL on January 3rd by the senior member of the printing staff of the BRITISH MEDICAL JOURNAL:

Dear Sir,

At a specially convened meeting held on January 1st, the Printing Staff of the BRITISH MEDICAL JOURNAL resolved unanimously to tender you their sincere congratulations on receipt by you of the honour of knighthood at the hands of His Majesty the King.

The Printing Staff feel that your arduous labours on behalf of the Medical Profession, on the one hand, and of suffering humanity on the other, richly deserve this well-merited recognition by the head of the State; they also trust you may be spared for many years to continue your good work and enjoy the honour conferred upon you.

On behalf of the Printing Staff, I beg to remain,

Your most obedient servant,

J. R. PEABEE,
Father of the Chapel.

Sir Dawson Williams,
Editor, BRITISH MEDICAL JOURNAL.

British Medical Journal.

SATURDAY, FEBRUARY 26TH, 1921.

HOSPITAL STAFFS.

THE discussion on the future provision of hospitals, and particularly as to the maintenance of the voluntary system, has during the last few months passed into a more satisfactory phase. Hasty generalizations and panic-stricken suggestions, turning everything topsy-turvy, have given place to a spirit of reasoned inquiry and careful investigation of facts. The proposal contained in the hospital clause of the Ministry of Health (Miscellaneous Provisions) Bill would have given the council of a county or county borough power to establish and maintain a general hospital: the council would have had power to borrow money, if necessary, in order to establish the hospital, and would have maintained it out of the rates. Very little consideration of the inevitable effect of these proposals in checking the flow of public benevolence was sufficient to convince all persons acquainted with the way in which voluntary hospitals are maintained that the clause would, if carried into law, before long bring the voluntary system to an end. Dr. Addison consented to withdraw the proposal and undertook to appoint a committee to inquire into the financial position of voluntary hospitals. The clause as it reached the House of Lords still provided that a county council should have power to take over a Poor Law hospital or infirmary and maintain it as a hospital for the treatment of illnesses or diseases generally or for any particular illness or class of illness. The rejection of the whole bill on the second reading in the House of Lords has not interfered with the activities of the committee which is now sitting under the chairmanship of Viscount Cave, and evidence has been given before it on behalf of the British Medical Association.

It is of course obvious that the medical profession is greatly interested in many parts of the subject Lord Cave's committee is considering. The British Medical Association was in fact the first to draw attention to an aspect of the matter which has since attracted a great deal of notice. The conference of staffs of voluntary hospitals, held at Cambridge during the annual meeting last year, to consider the question of the treatment of State-supported patients, had for one result that it brought into prominence the fact that the number of such patients is very considerable. Another conference on the same subject was held in London on December 21st, when resolutions were passed reaffirming the belief that the existing method of maintenance and staffing of the voluntary hospitals is to the advantage of the public and medical science, and of the medical profession. The subject has been fully discussed also at conferences of the profession in Scotland, held in Edinburgh at the end of July and early this month. As will be seen from the report published in the SUPPLEMENT this week, the conference in Scotland arrived at the conclusion that the present methods of administration of the voluntary hospitals should be continued, and the opinion was further expressed that it was not desirable that voluntary hospitals should be subsidized by the local rating authorities, except in so far as payment is made for the examination and the

care of patients for whom these authorities are responsible. There is thus general agreement that the status of patients for whom the State is responsible differs from that of other hospital patients, and that not only should the hospitals be reimbursed for the cost of maintenance, but the medical staffs should receive remuneration for their treatment.

The recent report of King Edward's Hospital Fund for London, to which reference was made in our issue of February 5th, has stated the position with regard to hospitals in London very clearly, and the same principles apply to many other voluntary hospitals, including practically all those in other large cities. The Council of the Fund pointed out that as the demand for hospital treatment grows the voluntary system must either expand so as to meet the whole of the growing demand, or confine itself to meeting the whole of the need in the particular kind of demand which it may be best fitted to meet, refraining in the latter case from opposing the establishment of other agencies to meet other parts of the need. It is suggested that different plans may be appropriate to different localities or to different kinds of hospital, and at the first conference of the British Medical Association—that at Cambridge—it was pointed out that the teaching hospitals formed a very special case. The staffs of such hospitals will, as a rule, prefer to be paid for their work as teachers rather than for the time and skill they give in the treatment of patients.

There seems to be a good deal in the argument of the King Edward Hospital Fund that, as the present sphere of the voluntary hospital is the result of a process of specialization, so possibly the best use of the voluntary hospital accommodation and equipment, present and future, would be promoted by some further development of this principle of partial specialization, the specialization taking place probably best between a parent hospital and branches, such as homes of recovery, convalescent homes, or, as has happened at St. Mary's Hospital, London, between the voluntary hospital and the non-voluntary hospital, established possibly in a Poor Law infirmary, and maintained by a local authority under some such provision as that in the Miscellaneous Provisions Bill of the Ministry of Health.

THE FOOD FACTOR IN PELLAGRA.

ALTHOUGH the etiology of pellagra is still in doubt the belief that it is due to a defect in diet has gained ground. Castellani and Chalmers, in the last edition of their *Manual of Tropical Medicine*, observe that modern work tends to support the theory that the absence of a vitamine is the true cause of the disease, but they recognize that there are difficulties in the acceptance of this view. A diet largely of maize, especially if damaged, has been believed to be the cause: maize in itself cannot be the cause, as the disease occurs in countries—as, for instance, England and Scotland—in which maize is not a staple article of diet. Possibly an explanation of the belief is to be found in the fact that in regions where maize is a staple food the diet has a low protein value; the absence or the presence in insufficient quantities of a vitamine may also play some part in causation. Any careful contribution to the subject is therefore to be welcomed, and we propose to give a short account of the results of an interesting experiment recorded in the *Bulletin* (No. 120) of the Hygienic Laboratory of the United States Public Health Services, for the facts have some bearing on general principles.

The experiment, which resulted in the production of pellagra, is described by Joseph Goldberger and G. A. Wheeler. The subjects were adult male convicts who volunteered. Of the 12 who entered the experiment, 11 remained throughout; one had to be released on account of a physical infirmity. The controls to the experiment consisted of 108 convicts, of whom 35 were under observation for a period comparable to the period of observation of the subjects of the experiment. Minute precautions were taken to ensure the segregation of the volunteers and to exclude all factors, such as risk of infection, which might have complicated the results. The volunteers were required to do light work. The experiment fell into two periods—one extending from February 4th to April 19th, during which the volunteers were kept under observation without any change in the regular prison fare. Pre-existing pellagra was thus excluded. The second period extended from April 19th to October 31st; during it the volunteers subsisted on the experimental diet. The diet of the convict controls provided an average of approximately 3,500 to 4,500 calories, yielded by about 90 to 110 grams of protein, 95 to 135 grams of fat, and 540 to 580 grams of carbohydrate. Approximately 20 to 35 per cent. of the proteins was from animal food. This diet was superior to the experimental diet with respect to the proteins, mineral constituents, and antineuritic and fat-soluble vitamins. The ingredients of the experimental diet were highly milled wheat flour, maize meal and grits, corn-starch, white rice, cane sugar, cane syrup, sweet potatoes, pork fat, cabbage, "collards," turnips, turnip greens, coffee, baking powder, salt, and pepper. During the first three months some buttermilk was used in making wheat biscuits. The average intake of the volunteers varied approximately between 2,500 and 3,500 calories. The average intake of protein varied between 41 and 54 grams, of fat between 91 and 134 grams, and of carbohydrate between 387 and 513 grams; 80 to 90 per cent. of the total protein was from cereal sources (wheat, maize, rice). The antineuritic vitamin content was planned to be low, but in the absence of any distinctive clinical manifestations of beri-beri the observers consider that the amount of this vitamin was not appreciably deficient for the needs of the volunteers during the period of study. Similarly, in the absence of recognizable indications of scurvy the diet was considered to have included an adequate supply of antiscorbutic factor. With regard to the adequacy of supply of vitamin A the observers found it difficult to judge by reason of the meagreness of the available fundamental data; none of the volunteers, however, developed xerophthalmia. The intake of mineral ingredients of the diet was decidedly low.

On this dietary six out of eleven convicts who were submitted to the test for its full period developed pellagra; the characteristic rash occurred with particular frequency on the scrotum. The observers conclude that "in relation to the production of pellagra the study suggests that the dietary factors to be considered as possibly essential are (1) an amino-acid deficiency; (2) a deficiency or faulty constitution of the mineral supply; possibly, but doubtfully, (3) a deficiency in the fat-soluble vitamin intake; and, perhaps, (4) an as yet unknown (vitamin?) factor. As to which or what combination (or combinations) of these constitutes the specific pellagra-producing dietary defect or defects remains to be determined. The experimenters attach little importance to the low content of the food in "anti-neuritic" vitamin.

In another paper M. X. Sullivan deals with the effects of this pellagra-producing dietary on fowls,

pigeons, and rats. He found that fowls speedily began to suffer from polyneuritis, pigeons had convulsive seizures and a few typical polyneuritis; rats speedily lost weight, and exhibited marked evidence of malnutrition, several dragging their hind limbs a short time before death.

The Goldberger diet was thus markedly deficient in antineuritic vitamin for animals, and therefore deficient in this vitamin for man. On the evidence afforded by these papers, it would seem that Goldberger and Wheeler have attached too little importance to the effects of an insufficient supply of vitamins in the production of pellagra. The work of British observers in this field of research would appear to link up with that of their American colleagues. McCarrison, in papers published in this journal, has drawn attention to the profound changes in the digestive organs which result from deficiency of vitamins, changes which would appear to simulate closely those found in pellagra. He has insisted that the term "antineuritic" as applied to vitamin B is misleading, since it directs attention to changes in one system of the body only, while others of equal importance take place earlier, such as those in the organs of digestion and assimilation which lead to the early appearances of digestive disturbances. He has shown also that deficiency of vitamins causes profound changes in the endocrine regulators of metabolism, and especially in the suprarenal glands. May it not be that the inadequate supply of protein to the body tissues, shown by the work of the Committee of Inquiry into Pellagra among Turkish prisoners of war to be so important in the genesis of pellagra, is due primarily to a failure in the organs of digestion and assimilation and of the endocrine organs, consequent on vitamin deficiency? Goldberger and Wheeler appear to have excluded the antiscorbutic factor as devoid of importance in their dietary; but here again McCarrison's work has emphasized that profound changes take place in the suprarenals before clinical evidences of scurvy are present.

The American observers are to be congratulated on their admirable contribution to our knowledge of pellagra. It seems probable, however, that while the suitability of protein is of the highest importance, it is not likely to be adequately utilized by the body tissues in the absence of a sufficiency of vitamins.

THE CZECHO-SLOVAK PUBLIC HEALTH DELEGATES.

The delegation from the Ministry of Public Health and Physical Education of Czecho-Slovakia, to which reference was made last week, spent altogether rather more than a fortnight in England. They were the guests of the International Health Bureau (Rockefeller Foundation), and their visit to this country was preceded by a two months' tour of the United States; they have now gone to Paris. In London they have had the advantage of hearing a detailed exposition of health administration in England and Wales from Sir George Newman and other medical officers of the Ministry of Health, followed by a series of lectures and demonstrations on special subjects. Among these has been a lecture on special schools for deaf and dumb and crippled children, by Dr. Eichholz, of the Board of Education; on maternity and child welfare, by Dr. Janet Campbell; on port sanitation, by Dr. R. J. Reece; on food inspection, by Dr. A. W. J. MacFadden; and on the voluntary general hospitals, by Sir Napier Burnett. The clinical unit system at University College Hospital has been explained to them by Professor T. R. Elliott, the

venereal disease clinic at St. Thomas's by Lieut. Colonel Harrison, the most recent appliances for field sanitation by Colonel P. S. Lelean, at the Royal Army Medical College, and the training of sanitary inspectors, by Mr. E. W. Wallis, at the Royal Sanitary Institute. A visit has also been paid to the Medical Research Council's laboratories, the Government lymph establishment, and a model farm for milk production. Opportunities have been given for the inspection of the arrangements of the Metropolitan Water Board for pumping, storage, and filtration, the London fever hospital and ambulance service, and the control of the city markets. A day has been found for the enjoyment of municipal hospitality at Brighton, where the delegates inspected a sanatorium and an open-air school of a new type, and on another day they were the guests of Cambridge University. In summarizing their impressions just before departure, the delegates said that of all the institutions which they had learnt even in a short while to admire in England, the voluntary hospitals were pre eminent; in their own country the hospitals are county or State institutions. Next to these the English system of school hygiene most impressed them, and they hope forthwith to establish a similar system of medical inspection and treatment in the schools of Czecho-Slovakia. From the general efficiency of our municipal health service, particularly in connexion with tuberculosis and venereal diseases, they gathered the lesson that it was very important that the areas of administration should be sufficiently large, and they proposed that such work in these directions as is done in Czecho-Slovakia shall be transferred from the authorities of small districts to the authorities of counties. The education of sanitary inspectors and health visitors has interested them, and though it would not be possible for them to copy the English system in its entirety, they hope to make use of some of its suggestions. At Dr. Addison's invitation the delegates had an opportunity of studying housing schemes in two localities, and expressed admiration for the way in which the Ministry of Health had tackled a problem of which they had had some experience in Prague. In expressing their thanks for the kindness and hospitality they had everywhere received, they expressed special appreciation of the assistance of Dr. J. A. Glover, of the Ministry of Health, who had accompanied them throughout their English tour. The Ministry of Public Health in Czecho-Slovakia, which was set up on the formation of the Republic, has control of physical education as well as of public health proper. Physical education is compulsory both for males and females—for males up to 21, when they enter military service—and the provision of building and equipment for this purpose is incumbent upon every locality. One of the visits paid by the delegates was to the Dartford Physical Training College, and it is hoped that teachers of physical training in Czecho-Slovakia may be sent to Dartford to complete their studies. Another thing which is compulsory in Czecho-Slovakia is a triple vaccination against small-pox—in infancy, at 7 years of age, and on leaving school. In the State budget for 1921 the amount allocated for public health is 80 million krone, or about 1 per cent. of the whole budget; this relates only to the central administration, and the expenditure of the local authorities, which are charged with the upkeep of most of the hospitals, brings up the amount to about four times as much.

CANCER MORTALITY.

THE recent report of the Registrar-General shows that there was no material change in the rate of mortality from cancer during 1919. The deaths ascribed to cancer during that year numbered 42,144; the numbers for both sexes (18,723 males and 23,421 females) were higher than any previously recorded. In 1909 the total was 34,053 (14,263 males and 19,790 females). The increase has been in cases returned as carcinoma or as cancer. The sarcoma in cases

have been almost stationary for the last few years. During the war it was not possible to take into account the whole male population, and the figures showed a very high mortality for males aged 15 to 45. It was suspected that this rise was artificial, being due to the rejection of sufferers as unfit for military service. This suspicion is now confirmed by the return with demobilization of male mortality at ages 15 to 45 to its pre-war level: it was 179 per million in 1911-14, and 178 in 1919. With one exception (70 to 75) all the higher ages show an increase over 1918, so that the standardized total rate for males has increased from the comparable figure for 1918 (which was 912) to 943 in 1919. No such general increase in age group mortalities applies to females, and although their crude rate has increased appreciably their standardized rate remains, as in 1918, a trifle lower than before the war. The increase in the crude rate must be due to the rapid diminution of the proportion in the population of the young, whose mortality is very slight. There has been no real fall in the total rates of persons of both sexes: they are a little higher than in 1911-14. Tables showing the organs attacked in fatal cases of cancer are given; their principal features are very much the same as for many years past. It is strange, and as far as we are aware unexplained, that while the mortality of females from cancer of the upper portion of the alimentary canal—namely, the part above the stomach—is a small fraction only of that of males, yet females suffer to about the same extent from cancer of the stomach and more from intestinal cancer: 1,329 cases of cancer of the oesophagus are recorded in males, against 376 in females. Cancer of the rectum also is a good deal more frequent in males than in females; so also is cancer of the lip, tongue, mouth, and jaw. The excess of cancer mortality in the female sex is dependent upon diseases of the breast and generative organs, the number of females dying from cancer of these organs being 9,309, as compared with 903 males. If deaths from these causes be excluded in both sexes the deaths of females are reduced from 23,421 to 14,112, and those of males only from 18,723 to 17,820. Tables giving the site of fatal cancer in relation to age and sex appear to show that in both sexes the age of greatest mortality is 55 to 75, and, with few exceptions, in all the organs enumerated. The number of deaths attributed to tumours not cancerous, or not ascertained to be cancer, was 2,117: of these, 975 were due to tumours ascertained to be not malignant. Among these were 313 uterine tumours, including 242 fibroid tumours, and 273 ovarian tumours, of which 216 were cystic. Of the remaining 1,142 cases of undetermined nature 783 were cerebral tumour; in the large majority of such cases the nature of the tumour was not stated.

SCHOOL PUNISHMENTS.

CANING on the hand as a school punishment was generally condemned at a meeting of the Medical Officers of Schools Association on February 15th. The occasion was a paper by Dr. E. H. F. Nash, who had elicited expressions of opinion from other medical officers of schools by circulating a list of questions. Chastisement in school is most commonly administered by means of the cane, the birch, and, in Scotland, the tawse—a leather strap with a fringe-like end. Occasionally Dr. Nash has found a flat or round ruler, or even a fives bat, employed. The cane, which is the instrument most generally employed in State-provided schools, may inflict great pain and cause much bruising; it is exceeded in these respects only by the ash stick. The birch, still the approved instrument in many public schools, stings severely at the time, but the effect is more transient and the bruising less marked. The fives bat and the flat ruler do not cause undue pain unless brought down on their narrow edge, but the round ruler should be put out of court altogether. As for the site of application, Dr. Nash insisted that the buttocks are much safer and more effective than the hand; thanks to the strength of the gluteal muscles, it is all but impossible to do serious

damage unless there is actual breach of the skin. Dr. Nash had not come across a single instance of damage through the application of the rod to the buttocks; the hind part of the thigh, however, is very tender, and again, if the punishment is inflicted higher in the back, there is danger of injuring a rib. Boxing a child's ears is to be unhesitatingly condemned, although it is true that few cases of rupture of the tympanum have been recorded. Dr. Nash said that he had seen grave damage done by the use of the cane on the hand—in one case such as to impair musical ability, at least during school age. With one exception, all who had replied to his questions condemned caning on the hand; one officer stigmatized it as a barbarous custom. It is continued on account of the objection of parents to the caning of their boys on the buttocks, which is considered derogatory. Caning on the hand, Dr. Nash contended, should be ruled out from school punishments, on medical grounds, but the use of the tawse on the hand might be permitted. With regard to other kinds of punishment, Dr. Nash held, as did other speakers, that so important a part of the physical education as drill ought not to be associated in a lad's mind with the idea of penalty.

MEDICAL EDUCATION IN CHINA.

Two hundred years ago medical science in China was perhaps not far behind that of any other country of the world, but since that time, owing to the absence of hospitals and medical colleges, no progress has been made. Western medicine was introduced into China a hundred years ago by Colledge, a surgeon of the East India Company, and during the past century a large number of mission hospitals were opened in connexion with the missionary effort that is carried on in all parts of the country. These hospitals met with marked success, but it was not until 1881 that the first Chinese medical college was established at Tientsin; six years later a second medical college for Chinese students was founded at Hong Kong, and other medical schools gradually came into existence. The first step in the development of medical education in China consisted in the gathering together of small groups of student assistants at various centres where there were active mission hospitals. These students attended such classes as the busy practitioner was able to give them, but the training that they obtained was chiefly of a practical nature, and laboratory classes were almost unknown. The next step was the establishment of small union medical colleges at the chief cities by the co-operation of various missions; these colleges were sparsely equipped, and all were undermanned, but in them continuous instruction was made possible, and regular laboratory work of a limited character was also instituted. It was by the amalgamation of three of these colleges that the present flourishing school of medicine of the Shantung Christian University was formed. In the year 1915 the Rockefeller Foundation, acting on the report of an influential commission which had visited the country, established a special board for the purpose of assisting medical education in China. This board took over the Peking Union Medical College by arrangement with the London Missionary Society, and reorganized it, making the English language the medium of instruction. The three junior classes of students were transferred to the school of medicine of the Shantung Christian University at Tsinan, in the support of which the Rockefeller Foundation assisted, and where teaching is conducted in the Chinese language. The training of Chinese nurses is being carried on at a modern hospital of over a hundred beds at Tsinan, along with the training of the Chinese medical students; and a nurses' association has been formed, which has done much to fix the status of its members in the estimation of the people. At the Royal Society of Medicine, on February 21st, Mr. Harold Balme, Dean of the Faculty of Medicine of the Shantung Christian Univer-

sity, described to a meeting of members of the medical profession (see p. 308) the development and the present needs of medical education in China. The audience were gratified to learn of the sympathetic attitude which the present Chinese Government has adopted towards the development of education and of medical science in general. The members of the medical profession in Great Britain can help the cause of medical education in China by making themselves acquainted with the facts, by recruiting suitable men for the various posts which become vacant, by obtaining financial support for the project, and by the personal interest which they could show in Chinese graduates visiting this country, more particularly in the provision of post-graduate facilities.

DANGERS OF THE DOMESTIC GAS SUPPLY.

Two committees have recently been set up by the Board of Trade: one to consider the question of the limitation of carbon monoxide content in town gas, and the other to consider that of "inerts"—that is, incombustible constituents. At the first sitting of the former committee, on February 10th, evidence was given by Dr. J. S. Haldane, who said that the poisonous action of illuminating gas was entirely due to the carbon monoxide (CO) it contained. The lowest proportion which would in time produce nausea and headache and other symptoms was about 0.2 per cent., but in the course of some experiments he had found himself able to endure up to 0.6 per cent. without symptoms, as a result of getting acclimatized. When pure coal gas was distributed the risk of poisoning was negligible, but when carburetted water gas, containing about four times as much CO as coal gas, was supplied the risk went up about sixty-fold. The ratio of risk from CO increased out of all proportion to the increase in its percentage. The chief danger was due to burners turned on accidentally in bedrooms. He had allowed pure coal gas, containing about 7 per cent. CO, to escape in a room of about 1,000 cubic feet space, at the rate of about 40 or 50 cubic feet of gas an hour, and found it almost impossible to get a poisonous atmosphere at sleeping level; the gas tended to go to the roof, and only descended in small proportions. But a poisonous atmosphere was readily produced when the CO in the gas was increased three or four times—say to 20 per cent. In a room of the size just mentioned the maximum final percentage of CO in the air with gas containing various proportions of CO would be as follows: In gas containing 5 per cent. CO the maximum final percentage of CO in the air was 0.05 per cent., in 10 per cent. it was 0.09 per cent., in 15 per cent. it was 0.13 per cent., and in 20 per cent. 0.18 per cent. The lowest proportion of CO in the air which would endanger life within about twelve hours was, according to the susceptibility of the person, from 0.15 to 0.3 per cent. Dr. Haldane's suggestion was that a definite maximum of 20 per cent. CO in illuminating gas for domestic purposes should be laid down. At a previous inquiry twenty years ago he had advocated 12 per cent., but distribution of gas and pattern of burners had improved in the meantime. The other witnesses at the first sitting were two chief engineers and a chief chemist of gas undertakings. All three were strongly against the fixing of any limit for CO. One of them, representing the Gas Light and Coke Company, stated that, taking the ten years during which the largest quantity of carburetted water gas had been supplied by his company, 15 deaths had occurred in the area from accidental inhalation; in 3 other cases of sick people death had been accelerated by gas, and there were 11 cases of gas suicide. A Liverpool gas engineer gave figures for the last twenty years, during which there had been 38 fatalities attributed to accidental gas poisoning and a further 16 due to suicide. Of the 38 cases 22 were in districts supplied with gas containing less than 12 per cent. of CO and 16 in districts supplied with gas containing a higher

proportion. Medical opinion will, we believe, look upon arguments of this nature with suspicion. Carbon monoxide is an extremely dangerous gas, since it attacks the haemoglobin of the blood and is only slowly and with difficulty expelled. Moreover, being colourless and odourless, its presence in a room tends to mask an escape of coal gas, while greatly adding to its dangers.

THE BIRTH-RATE COMMISSION ON VENEREAL DISEASE.

THE voluntary organization known as the National Birth-rate Commission, which began its labours in 1910, and has already issued reports on the declining birth rate and problems of population and parenthood, has now completed a report on the prevention of venereal disease, which will be published by Messrs. Williams and Norgate on February 28th. The witnesses who advised a special committee on venereal disease of the Birth-rate Commission numbered over a score, and included physicians, surgeons, and venereal specialists of both sexes, medical officers of health, social workers and ministers of religion, medical officers of the British and American armies, representatives of the Ministry of Health, and of the two well known societies with somewhat conflicting views upon the problem of venereal disease. The conclusions reached are summed up in two sections, one on the medical aspects of the subject and the other on the moral aspects. The committee, although realizing that chastity is the best safeguard against the spread of venereal disease, recognizes that a large number of persons, male and female, will not respond to such moral appeals. It believes, therefore, on grounds of both national and individual welfare, that it is of importance to prevent by all legitimate means the development of disease in those who expose themselves to the risk of infection. It considers that some method of disinfection must be carried out as soon as possible after sexual intercourse; but the results in preventing the development of disease depend largely, it is stated, on the interval of time elapsing and the care with which the disinfecting process is carried out. In this the report appears to agree with the policy of the Society for the Prevention of Venereal Disease in recommending some form of "early self-disinfection." The report points out that the Act at present in force prevents individuals from obtaining the necessary antiseptics from chemists, and it recommends that chemists should be allowed to sell disinfectants with instructions. The committee thinks that the Ministry of Health should, through local health authorities, draw public attention to the menace to national health and welfare arising from venereal disease; and while it recommends the continuance of the early treatment centres at Manchester and elsewhere for a time, it is of opinion that it is undesirable to provide further expensive ablation centres before it has been definitely ascertained that men are unable by other means to disinfect themselves efficiently. In dealing with the relation of the moral to the medical aspects of the problem the view is expressed that a medical man in dealing with these diseases, or in proposing means for their prevention, cannot divest himself of his responsibility as a moral agent dealing with patients who are also moral agents. The moral appeal by its very nature must be the more enduring, and it is recommended that, in view of the serious situation, parents, teachers, and ministers of religion, social reformers, and medical practitioners, legislators and administrators, should combine in a national effort to assert the moral obligation of chastity, the sanctity of marriage and parenthood, and the equality of the moral standard for the two sexes.

PHYSIOLOGY AT SOUTH KENSINGTON.

THE Faculty of Medicine is considering this week the proposal of the Senate of the University of London to close the University Physiological Laboratory at the end

of July, in order to provide university headquarters with more extensive accommodation for clerks, and, as has already been stated, the subject will be before the Faculty of Science—that most directly concerned—next week. It is probable that both faculties will take the view that the suggested closure would be a grave injury to the advancement of medical science, and recommend that the laboratory should be continued as a valuable part of the work of the University. A correspondent has called our attention to a memorandum written by the Prince Consort in August, 1851, at the end of his tenure of the chairmanship of the Exhibition Commission of that year. The memorandum mentions that ground was then available in Kensington Gore, and suggested that it should be purchased and four institutions erected on it—the first for metallurgy, metallurgical chemistry, and animal and vegetable physiology; the second embracing polytechnic science, with its subdivisions; the third a school of design and chemistry as applied to manufactures; and the fourth devoted to architecture, antiquities, and sculpture. In the following year ninety acres were acquired at a cost of £342,500, upon which now stands the Albert Hall, the Royal College of Music, the Imperial Institute, the Imperial College of Science and Technology, the Natural History Museum, and other educational buildings; thus, as our correspondent points out, more than realizing in the material, if not in the spirit, the intention expressed by the Prince Consort in 1851. It will be observed, first, that a site larger either than that at Holland Park or Bloomsbury was acquired for purposes of higher education and research seventy years ago, and secondly, that physiology was among the subjects of research and instruction to which it was at that time proposed to devote the site.

A WAR SECTION OF THE WELLCOME MUSEUM.

A SECTION illustrating naval and military medical service during the war has been added to the Wellcome Historical Medical Museum. It is not of great dimensions, but is an assembly of some typical exhibits, which may yet be enlarged by the loan of trophies by ex-officers and others. Ambulance arrangements are the subject of a gallery of photographs so selected and placed as to tell a story instead of bewildering the visitor with a jumble of impressions. Every kind of transport for the wounded seems to be included in these pictures, from the well-equipped hospital train to the mule *travois* of the Balkans and the camel cacolet of further east. Naval ambulance, which was fully described in a series of articles published in the BRITISH MEDICAL JOURNAL of April 28th, 1917, is illustrated by photographs, models, and an example of the slung cot used both ashore and afloat. A number of contemporary drawings and paintings have found a home in Wigmore Street. In contrast to Matania's sketch of the aerial transport of the wounded on the Italian (Alpine) front, there are the post-cards coloured by a R.A.M.C. sergeant with the help of Condy's fluid and tincture of iodine. A collection of orthopaedic appliances is a feature of the section. The curator, Mr. C. J. S. Thompson, is justifiably proud of having secured a number of articles in papier-mâché, leather, and common canvas, which were worked by the skilled fingers of the English ladies in the Palazzo Centurione in Rome. Various protective devices are on view, including smoke helmets, anti-gas apparatus with respirators, the masks and gloves used to guard against the back-flash of big guns, and various kinds of goggles; one pair of these, as a protection against shell splinters, is on the principle of the Eskimo snow spectacles, with the narrowest possible slits for vision. Some of the exhibits go back earlier than the recent war. The telephone probe is supposed to have originated with Graham Bell, and to have been first applied in this country by Mackenzie Davidson. But it was anticipated to some extent by Sir Thomas Longmore, and the instrument which he devised in the middle of the nine-

teenth century is here on exhibition; it is a bullet-detector in which a compass is employed to signify by the deflection of its needle when contact is made between the dependent probe and the foreign body. Another exhibit consists of field dressings, including the compressed bandage used in the Crimean war, the first antiseptic wound-pad, dated 1883, and the first field-dressing served out in 1914; also a bandage prepared from the bark of a tree by the Germans in East Africa. The contents of a German field valise are well worth study for the compactness and ingenuity of the arrangements. In the surgical instrument case the distinctive outline of each instrument is marked on the outside of the pocket into which it is to go, so that there may be no mistake in replacement. One case is filled with hospital equipment taken from a German cruiser in 1918. One of the U-boats has yielded up to the Wellcome Museum its oxygen cylinders and attachments. Lastly, there is a replica, in gilded copper, of the mace presented to the American College of Surgeons by the consulting surgeons of the British armies in memory of mutual work and good-fellowship in the great war.¹ It has been finished by hand by Mr. Omar Ramsden, the gifted worker of the original. The Curator is indebted to Surgeon Captain M. Knapp, R.N., and Lieut.-Colonel Brereton for their kind assistance in procuring and describing many of the exhibits.

THE POSITION OF THE FINE CHEMICAL INDUSTRY.

THE Association of British Chemical Manufacturers is circulating a memorandum on the present position of the fine chemical industry. The facts and arguments are on similar lines to those in the pamphlet issued from the Society of Chemical Industry already noticed in these columns. It is stated that British chemists, as a result of the stimulus imparted by the war, have brought the manufacture of the chemicals used in research and in photography, and of certain synthetic perfumes and essences, to the verge of commercial success, while the manufacture of drugs has made immense strides, and would have made greater had not the Order in Council prohibiting the importation of drugs been set aside by the Sankey judgement. The hope is expressed that the Key Industries Bill, which has been promised as a Government measure of the new session, may do for fine chemicals what has already been done for dyestuffs by the Act recently passed: that is to say, that some protection may be granted to the manufacturers of fine chemicals until they have consolidated a position which has been hardly won and which is still precarious. The insecurity arises from the fact that there are circumstances, including the great priority of organization, and also the present state of the exchanges, which favour the German laboratories. The national importance of this industry in peace and war is pointed out, and it is also stated that, excluding coal-mining, the fine chemical industry yields the highest net value of output per person employed.

THE WAR FINANCE OF THE RED CROSS AND ST. JOHN.

THE accounts of the Joint War Finance Committee of the British Red Cross Society and the Order of St. John from October 20th, 1918, to June 30th, 1920, have been issued, together with a final report on the financial operations of the Committee, and a summary of accounts from October 20th, 1914, to June 30th, 1920. The latter will be included in a detailed record of the whole war work of the joint organization which has been in preparation since the Armistice, and will be published shortly. The joint organization of the two corporations, set up for the purposes of the war, was placed under the financial control of a Finance Committee, which was presided over by Sir Robert Hudson, G.B.E., and annual accounts were rendered throughout the war. Some idea of the

magnitude of the financial work which fell to the Finance Committee will be gained from the fact that it has had to account for receipts amounting to £21,885,035 and expenditure £20,058,355. Of the receipts £16,510,023 were received in money from the public and £1,027,280 in kind; Government grants, interest, and various receipts from other bodies make up the total. The chief items of expenditure were £2,053,501 for the transport of wounded; £2,928,367 for hospitals, not including local expenditure on the auxiliary home hospitals; £5,017,285 for stores; £5,147,876 for prisoners of war, and £2,717,927 for post-war schemes for sick and disabled ex-service men and kindred objects. These last services were provided by the Red Cross and St. John Act of 1918, which governs the disposal of any surplus. The surplus on June 30th last amounted to £1,826,680. Claims upon the surplus on behalf of the wounded will continue to be received for a long time to come, and the Committee in its report foreshadows the development of a scheme throughout the country for the benefit of disabled ex-service men. Copies of the accounts can be obtained from the inquiry office 19, Berkeley Street, W.1., at the price of 1s. each.

THE Morison Lectures will be delivered before the Royal College of Physicians of Edinburgh by Sir Frederick Mott, F.R.S., on Monday, Wednesday and Friday, March 7th, 9th, and 11th, at 5 p.m. on each day. The subject of the course is "The Psychopathology of Puberty and Adolescence." The lectures will be illustrated by drawings and lantern slides. The first lecture will deal with the reproductive organs in relation to the endocrine glands and the autonomic nervous system; the second and third with the pathology of dementia precox.

A NEW edition of Liddell and Scott's *Greek Lexicon* has been on the stocks since October, 1911, when Mr. Henry Stuart Jones was appointed editor. He has had the assistance of many specialists and a large number of voluntary readers who have undertaken to read for the dictionary. Among the specialists who have given their help are Sir W. Thiselton-Dyer, F.R.S., who has an extensive acquaintance with Greek botanical terms, and Dr. E. T. Withington of Oxford, who has read the whole of the voluminous literature of Greek medicine, with the result that practically all the articles on medical terms have been rewritten and considerable additions have been made to the vocabulary of the subject. Recently Mr. Roderick Mackenzie has been appointed assistant editor, and the Secretary to the Delegates of the Oxford University Press has announced that it is hoped shortly to begin the printing. It is proposed to issue the new edition in ten parts of about 200 pages each, price 10s. 6d. a part, or a subscription price of four guineas. As the total outlay, it is estimated, will approach £20,000, it is unlikely that the sales will total this amount.

Medical Notes in Parliament.

Dangerous Drugs: Draft Regulations.

SIR THOMAS BRANDON asked the Home Secretary, on February 17th, if, in formulating the draft regulations for the sale, prescribing, dispensing, and distribution of cocaine, eugonine, morphine, heroine, and opium (medicinal), the British Medical Association, which represented and spoke for over 22,000 medical men, were not consulted; if he were aware that the proposed draft regulations were regarded by medical practitioners throughout the kingdom as impracticable; that if Clause 13 of the proposed regulations were strictly carried out it would be impossible for medical men to obtain those drugs from wholesale chemists by train or through the post; and that, however urgently needed, it would be impossible for a doctor to obtain these drugs by telephone message; and if he were prepared to submit the regulations for consideration and amendment to a committee composed of representatives of the Home Office, the Ministry of Health, the British Medical Association, and the Pharmaceutical Society, as well as of the

¹ BRITISH MEDICAL JOURNAL, October 16th, 1920, p. 597.

Veterinary Surgeons, as representing all the interests concerned in dealing with these drugs.

Other questions of a similar character were put by Lieut.-Colonel Hurst, Mr. Johnston, Mr. Trevelyan Thomson, Lieut.-Colonel W. Guinness, Mr. Clough, Sir Harry Hope, and Major Sir Bertram Falle. Sir John Baird, Under Secretary for the Home Department, made a statement on behalf of the Home Secretary. In the first place, he said, the Regulations were at present in draft only, and would not come into operation until they had been formally made. They were issued first in draft for the express purpose of giving all parties interested the opportunity of expressing their views before they were finally made. The criticisms that had been directed against the department for not having consulted this body or that before issuing the Regulations were, he thought, a little misplaced. Representations had been received from a number of bodies, and these were being carefully considered. Regulation 13 would be amended so as to make the meaning perfectly clear. Apart from these considerations a number of important points had been raised, and these were being, or would be, discussed with the representatives of the interests concerned. As regards the application of the Regulations to agriculture, the Home Secretary was in consultation with the Minister for Agriculture. Sir John Baird went on to say that the Regulations were proposed in order to carry out the obligations which the Government had undertaken under the International Opium Convention and the Treaty of Versailles to confine the uses of the drugs in question to medical and other legitimate uses. Parliament gave express powers for the purpose in the Dangerous Drugs Act of last session. The need for additional restriction, in view of the prevalence of the drug habit, would be generally admitted, but it was not the Home Secretary's desire or intention to impose any restrictions beyond what was necessary to effect the purpose; it was to meet the views that had been submitted to a very large extent. When the Regulations were finally made they would be laid before Parliament, and Parliament would have an opportunity of discussing them if it so desired. On further questions, Sir John Baird stated that the Home Secretary had promised to receive a deputation. The Home Secretary expected to be able to place the Regulations on the table in the course of next month. The matter was rather urgent, because, in the event of the treaty with Turkey being ratified, the Regulations under which restrictions were now exercised on the sale of opium and cocaine would lapse.

Medical Records.

Sir J. D. Rees asked, on February 21st, whether the new record card had been dropped, "in view of the almost universal objection entertained to this development of social reform." Dr. Addison replied in the negative, adding that from about 10,000 approved societies and branches he had received only five protests; out of 150 Panel Committees (representing insurance practitioners), five representations, mainly on points of detail; while from Insurance Committees (which administered medical benefit in every county and county borough) he had received no protest whatever; one large Insurance Committee, which had before it a resolution disapproving of the new medical card, rejected the resolution by 21 votes to 2. In reply to Sir D. Hall, Dr. Addison said that the annual cost of the records would be a small sum, and certainly considerably less than that of the old medical record card and doctor's register card, both of which would be replaced by the single new permanent record card. The cost of running the London Hospital in 1919 was £221,000, whilst the total initial cost to Insurance Committees—a charge which would not recur—for filling in and sending the record card to all the practitioners in England and Wales was estimated to be £19,000. Sir D. Hall inquired whether already under the new system of medical records of insured patients there had been cases of patients foregoing their benefits and incurring the expense of a private doctor rather than submit to a record of their complaints being made by the panel doctor on the record cards. Dr. Addison said he understood that allegations to the effect stated had been made in some two or three cases only out of a total of millions of insured persons. The fact that medical men, approved societies, and Insurance Committees, as well as insured persons having first-hand knowledge of these matters, had remained quite unmoved by the recent agitation was convincing proof of its unreal character.

The medical members of the House of Commons met on February 21st to consider the matter of the new medical record cards. Dr. Nathan Raw presided. A resolution was passed declaring that the principle of keeping a record was likely to result in permanent advantage to the insured person; and a further motion was adopted setting forth that the most jealous regard should be maintained for professional secrecy. In this connexion it was decided that a question should be addressed to Dr. Addison with the object of ascertaining whether or not the records could be called for in a court of law.

Lieut.-Colonel Fremantle asked the Minister of Health, on February 23rd, whether, prior to directing medical practitioners under the National Insurance Act to place certain confidential entries on medical history cards, he had consulted, or would consult, the law officers of the Crown as to whether the practitioners would be guilty of violating secrecy, and be liable to actions for libel if such entries were entrusted by them to private secretaries in accordance with their usual practice. Dr. Addison replied: I am advised that in the circumstances mentioned it is in the highest degree unlikely that there would be any cause of action against the doctor, unless he were shown to have been actuated by malice. The general question as to the position in the law of medical secrecy was submitted by me to the Lord Chancellor in June last year, and the matter, which raises very important issues, is being considered.

Lieut.-Colonel Fremantle also asked the Minister of Health if he had obtained, or would obtain, the opinion of the law officers of the Crown as to whether subpoenas might be granted, compelling the production of medical history cards in legal proceedings, and whether panel practitioners concerned in their preparation might be called upon to support the statements therein made. Dr. Addison replied: I am advised that though a person may be compelled by means of a subpoena duces tecum to bring any document, private or otherwise, to the court, the document itself does not thereby become admissible in evidence. A record card is, I am advised, not evidence of the facts stated in it, and if it is desired to prove them, this must be done in the ordinary way—namely, by the oral evidence of the doctor himself.

The Dogs Bill Reintroduced.—Sir Frederick Banbury, on February 18th, again introduced a bill to prohibit the vivisection of dogs. It was backed by Sir John Butcher, Colonel Burn, and Mr. Joseph Greer, and having been given a first reading, was put down for second reading on Tuesday, April 12th. Sir Frederick chose a date after Easter in anticipation that the Government would absorb all available time until Easter; and he was not fortunate enough in the ballot to be able, in seeking a later date, to get a Friday soon after Easter, which may be taken as the reason why he chose a Tuesday, which in the ordinary way will not give him an opening until the evening. The Friday sittings begin at noon.

Income Tax.—Mr. Chamberlain states that he hopes early in the session to introduce a bill dealing with certain important recommendations of the Royal Commission on Income Tax, and to include in this bill a recommendation as to the three years' average. He does not hope to change the law in time for the change to be operative in the coming financial year, but that he will get the legislation through so that the change may apply in the financial year following the coming one. The three years' average had been very much in favour of the taxpayer, who had had the advantage of it during the last seven years, and he must put up with it for one year longer although it might possibly result to his disadvantage.

London University: New Buildings.—Sir J. D. Rees asked, on February 21st, whether it was proposed, in view of the present state of the finances of the country, to give any assistance from public funds towards the acquisition of a site for, or the construction of, a new building for the University of London. Mr. Chamberlain replied that last October London University accepted the Government offer, made in the preceding April, of a site behind the British Museum, and the site had been purchased. For the funds required for building the University headquarters the University must look primarily to public generosity, but it would be open to the University Grants Committee to supplement local contributions if the funds at their disposal allowed.

The Murder of Canon Magner.—In regard to the case of Cadet Hart of the Auxiliary Division of the Royal Irish Constabulary, who was tried by court-martial on January 5th for the murder of Canon Magner and Mr. Timothy Crowley, Sir H. Greenwood stated on February 17th that the cadet was convicted of murder, but found to have been insane at the time of the commission of the crime. The medical experts who made this report were Colonel W. G. Bevels, C.B.E., A.M.S., A.D.M.S., Cork; Lieut.-Colonel Nicholls, R.A.M.C., Medical Officer, Cork Detention Barracks; Dr. William Dawson, M.O., H.M. Inspector of Asylums, Ireland; Dr. M. Hamblin Smith, Medical Officer, H.M. Prison, Birmingham; Dr. East, M.D., Medical Officer, Liverpool Prison, and Dr. Dyer, M.D., Medical Inspector of Prisons.

Chinese Flour.—Dr. Addison, on February 17th, answering several questions in regard to the use of Chinese flour in this country, said newspaper reports had alleged that cases of illness (especially skin eruptions) had occurred owing to the consumption of bread made from Chinese flour. Inquiries he had caused to be made had failed to establish any causal connexion between the flour in question and the illness complained of. Examination of some of the cases of skin eruption showed that they were due to scabies. In the samples of the flour examined, no flour other than that of wheat had been detected, and the condition of the samples, on the questions raised as to contents, was satisfactory.

Milk and Dairies Bill.—In answer to Mr. Swan, Dr. Addison said that it was not at present proposed to reintroduce the Milk and Dairies Bill during the present session.

ASSOCIATION OF PUBLIC VACCINATORS.

ANNUAL MEETING.

THE annual meeting of the Association of Public Vaccinators of England and Wales was held at the Queen's Hotel, Leeds, on January 28th, when Dr. C. J. PALMER (Mansfield) was in the chair. The report and balance sheet were approved and adopted. It was noted with satisfaction that the circular letter recently addressed to boards of guardians had in some cases been effective in securing an increase of fees for vaccination. The officers and council were elected for the ensuing year. Votes of thanks were accorded the retiring president (Dr. C. J. Palmer), the editorial secretary (Dr. A. Drury), and the organizing secretary (Mr. F. A. Briggs), for their valuable help during the past year. Dr. A. T. BACON (Leeds) was elected president, and received a hearty welcome on taking the chair vacated by the retiring president.

At the conclusion of the formal business a very interesting address was given by Dr. W. MCCONNELL WANKLYN on "The abolition of small-pox." Dr. Wanklyn's experience in dealing with small-pox outbreaks lent much importance to his address. He observed at the outset that his aim was to keep out small-pox, which was identical with the aim of vaccinators. The true policy and objective, he considered, was to attack small-pox, throw it out of the country, and keep it out. The year 1904 might be looked upon as a landmark in the control of small-pox in London. Thousands of lives and vast sums of money had been saved by the system then adopted, whereby suspicious cases could be seen at their homes at the very outset in consultation with the medical attendant. This led to the early recognition of cases. Early diagnosis was of the greatest importance. Dr. Wanklyn then depicted the natural history of small-pox. Recent prevalence showed that, though the periods of comparative quietness had been longer than formerly, there was still a definite risk of an epidemic. The risk was increasing, since infection was frequently imported and the susceptibility of the population was increasing. Paying a high tribute to the courage and bravery of the men of the Notts, Derby, and Leicester regiments, Dr. Wanklyn said he found himself attached to a division largely composed of these men during the war, practically all of whom were antivaccinators and opposed to inoculation against enteric. He talked to the men, gave them lectures, and found them willing to drop their objections; many thousands were vaccinated, and 95 per cent. of the division were inoculated. He urged the importance of instructing the laity. Every human being born was susceptible to small-pox. There was a world prevalence of small-pox at the present time, and all the trade routes lead to this country. A chart showed its prevalence in various parts of Europe, India, Japan, United States, Egypt, Africa, and Brazil. The cost of small-pox, which was enormous, must be reduced at once by the proper adoption of preventive measures, which were outlined. There was a possibility any time now of an epidemic of small-pox on a big scale. Once begun and established, the cost to the country of such an epidemic would amount to many millions of pounds. It would be calamitous to life, to business, to efficiency, to finance, and general health administration. It was our duty to do all things possible to prevent such a calamity.

ANNUAL DINNER.

In the evening the first annual dinner since 1914 was held, and there was a good attendance of members and friends. Dr. A. E. COPE (London) proposed "The President," to which Dr. BACON replied, "Our Guests" was proposed by Dr. DRURY (Halifax). The replies were given by Dr. J. R. KAYE (County Medical Officer, West Riding), Professor J. KAY JAMESON (Dean of the Faculty and Professor of Anatomy, Leeds University), and Dr. W. MCCONNELL (London). A most enjoyable entertainment was provided; Miss Marjorie Abercrombie gave songs, and Miss Margaret G. Drury a recital of serious and humorous selections.

A CONGRESS of school hygiene will be held in Paris next April under the presidency of Dr. Méry. Dr. Dufestel has been appointed vice-president and Drs. Genevriev and Mathé secretaries.

England and Wales.

LEICESTER PUBLIC MEDICAL SERVICE.

THE report of the Leicester Public Medical Service for 1920 has been issued and records the continued success of its work, the rate per capita paid to "acting members" of the service showing a substantial advance. The arrangement has been continued whereby free medical treatment is provided for the uninsured blind of Leicester, as has also been the co-operation with the Education Committee for carrying on the school clinic work at the central dispensary.

The annual report of the Leicester Subdivision of the Union of Medical Practitioners shows that the scheme of collective locumtenencies for the summer holidays, which was inaugurated during 1919, was successfully continued during the summer of 1920. Twenty doctors availed themselves of the facilities afforded, contributing to a pool which was distributed among the practitioners who attended patients under the scheme. Alterations have been made in the Public Medical Service rooms in order that they might be used as a club for the medical men of Leicester and the county. The rooms have been furnished, gifts of furniture, books, and pictures having been received, and billiard, reading, and writing rooms have been provided. The club is now called the "Leicester Medical Club," and is conducted by a committee, of which Dr. C. C. Binns is honorary secretary and treasurer.

SHEFFIELD EDINBURGH UNIVERSITY CLUB DINNER.

ON Saturday, February 19th, the Sheffield Edinburgh University Club held its tenth annual dinner, the first since 1914. Dr. G. Scott Davidson, president of the club, was in the chair, the croquiers being Drs. Blyth, Murray, and Anderson. The guest of the evening was Professor Caird of Edinburgh, and a company of just 100 members and guests was present to meet him. The toast of the Alma Mater was given by Dr. Yates in a charming speech reminiscent of his student days in the faculties of Arts and Medicine at Edinburgh. Professor Caird, in his reply, told delightful tales of those far-away days of the early seventies when he himself was a student. He was especially happy in his memories of "Old Woody Fibre" (Professor Hutton Balfour), "Dismal Jimmy" (Professor Spence), Pat, Watson, and Joe Bell. His story of the workman from the Forth Bridge who entered Bell's clinic carrying in his pocket a handkerchief which had been slyly soaked in ammoniacal urine by a student, thereby causing Joe Bell to make a wrong diagnosis for once, was greatly appreciated. He referred to the overcrowded condition of the university at the present time, and to the probability of an early rise in the fees at the university. The toast of the guests was given by Dr. Peck and responded to by Professor Leathes and Colonel Connell.

CENTRAL MIDWIVES BOARD.

THE Central Midwives Board met on Thursday, February 17th. A special meeting was held first, at which five midwives were struck off the roll.

At the ordinary monthly meeting when Sir Francis Champneys was in the chair, in reply to a letter from Dr. Comyns Berkeley, a minute was adopted stating that the Board had given very careful consideration to the request from the majority of its examiners for an increase in examination fees; but having regard to the fees paid by other examining bodies for work of a similar nature, and to the fact that the amount of the fees payable by candidates is limited by statute, the Board regretted that it did not see its way to grant an increase at the present time. Should the Board at some future time be enabled to increase the fees payable by candidates, it would reconsider the question of increasing the fees of its examiners. An application from the authorities of the Eden Hospital, Calcutta, that the hospital might again be approved as a training school was granted. In reply to an inquiry as to the jurisdiction of a local supervising authority to inquire into the conduct of a midwife when acting as a monthly nurse, the Board replied that the authority had jurisdiction to consider a charge of misconduct other than professional misconduct, if such misconduct tended to

unfit the midwife for the discharge of her duties as a midwife; this jurisdiction was not ousted by the fact that when guilty of such misconduct the midwife was not acting as either a midwife or as a monthly nurse. In the opinion of the Board, however, the Midwives Acts confer no jurisdiction upon either the Central Midwives Board or the local supervising authorities to investigate charges of malpractice, negligence or professional misconduct preferred against a midwife when acting as a monthly nurse, unless her conduct constitutes a violation of Rule E. 6 of the Board's rules.

Scotland.

EDINBURGH UNIVERSITY CHEMICAL LABORATORIES.

ALTHOUGH it is only a year since the work of building the chemical laboratories of the Edinburgh University at Liberton was commenced some of the rooms are already in occupation. Apart from the front portion of the building where the administrative offices and the library are situated, and which is in two stories, the building is of one story, and all the laboratories are lighted from the roof.

At present only the advanced chemistry students are accommodated at Liberton, but eventually when the buildings are completed the whole of the chemistry department of the University will be transferred to this site. At a later period buildings will be erected there to accommodate the Geology and Zoology Departments. There is a long central corridor from which the several laboratories open on one side. The buildings on the other side have yet to be erected. The laboratories are economically but fully equipped. There is ample bench accommodation for each student. Opposite his seat and at the level of his head is a draught hole which draws fumes into a system of air ducts. Leading off a long corridor parallel to the main corridor are research rooms, where advanced research students may carry on their individual work. The laboratories are under the supervision of Professor Sir James Walker.

GLASGOW ROYAL ASYLUM.

At the annual meeting on February 17th, of contributors to the Glasgow Royal Asylum, Dr. Oswald, physician superintendent, in a written review of the year's work, pointed out that a preponderance of female over male admissions, was, as in the previous year, a striking and remarkable feature. The only possible explanation seemed to lie in the fact that women nowadays were taking a much more active part than formerly in community life, in consequence of which a much greater strain was thrown on them, with the not unnatural result that there were a greater number of so-called nervous and mental breakdowns. It seemed, too, as though a contributory factor might be the reaction following the stress of war years. Dr. Henderson, assistant superintendent, said that the great difficulty in regard to mental treatment was that they could not get the patient to seek medical advice early enough. He thought that much good might be done if out-patient mental clinics were established, just as we had out-patient clinics for physical diseases. He urged also the desirability of occupational departments associated with mental hospitals, but separated from the wards of the institution.

CARNEGIE UNIVERSITIES TRUST.

The annual meeting of the Carnegie Trust for the Universities of Scotland was held in a committee-room of the House of Lords, on February 9th, with Lord Balfour of Burleigh in the chair. Lord Balfour said that the principal event of last year was the allocation of grants for the quinquennial period of 1920-25. In addition to the £200,000 from income, it had been resolved to allocate from the reserve fund £49,000. The explanation of this was that during the war the students at the universities were fewer, and therefore the trustees saved on the payment of fees. It would have been absurd to save that money and put it to the reserve, when many of the same students were coming back after the war and wanted it. The trustees thought it right, as a temporary measure, to take it out of the reserve fund, and give it to them to pay their fees. Under the research scheme it had been agreed that as an experiment for a period of three years the

following annual grants be offered to the universities to be spent in payment of half the salaries of persons engaged as part-time assistants or lecturers on condition that they devoted not less than half their time to research, and that the universities should contribute the other half of the salaries from other sources—Glasgow and Edinburgh £1,000 each, St. Andrews and Aberdeen £800 each. It was hoped that much good to the universities would result from this combination of teaching and research, and the scheme had been well received by the universities. Although the amount available for assistance to students was now fully £60,000, there was a deficit of £8,538 for 1919-20. The universities were now increasing their tuition fees, and as a result the poor student would be poorer than ever. Thus the difficulties were very great. For many years the trustees had been able to pay all eligible applicants the whole of their class fees, but in 1911-12 they had had to have an allowance system, because the income would not cover the whole of the fees, and since then the trustees had been paying only a part of the fees. The situation would be further changed in the current year owing to the increase in tuition fees.

The discussion, in which Lord Haldane, Lord Sands, and others took part, centred chiefly in the problem of allocating assistance to the students. It was agreed that steps must be taken to eliminate from the beneficiaries of the fund those applicants whose circumstances were such as to render assistance unnecessary. Proposals were made for strengthening the declaration made by applicants and for an inquiry into individual circumstances. The suggestions were discussed, but a decision will not be reached until the alternatives have been further considered in the light of the views expressed by university authorities and others interested.

EAST OF SCOTLAND OVERSEAS MEDICAL CLUB.

The second annual dinner of the East of Scotland Overseas Medical Club was held in Edinburgh on February 18th, when Professor Francis Boyd, C.B., C.M.G., president, was in the chair. There was a large gathering, many from distant parts of Scotland. The guests included Lieut.-General Sir Francis Davies, K.C.B., G.O.C. Scottish Command, Surgeon Rear-Admiral J. Stenhouse, R.N., Colonel Browne-Mason, D.S.O., D.D.M.S. Scottish Command, Mr. T. Kay, D.S.O., M.D., president of the West of Scotland Foreign Service Medical Club. Apologies were received from Sir John Goodwin, K.C.B., D.G., A.M.S., Colonel P. S. Lelean, C.B., C.M.G., and others. Amongst those present were Drs. T. F. Dewar, C.B., Henry Wade, C.M.G., D.S.O., Morrison McIntosh, C.M.G., C. E. Douglas (Cupar), R. A. Fleming, W. A. Taylor (Perth), William Haig, D.S.O. (Crieff), James Young, D.S.O., David Lees, D.S.O., J. F. Crombie, D.S.O., George Rae Gibson, D.S.O., Pirie Watson, O.B.E., D. P. D. Wilkie, O.B.E., J. W. Mackenzie, O.B.E. (Inverness), A. L. S. Tuke, M.C. (Dunfermline), W. T. Gardiner, M.C., Stewart Hodgson, M.C. The toast of "The Imperial Forces" was proposed by Dr. C. E. Douglas of Cupar, who recalled the time when this toast embraced the Navy, the Army, and the Volunteer Forces, and when the mention of the last was apt to be received with a smile. Those times had changed, and nowadays this toast might be considered as embracing within its compass the whole nation. Lieut.-General Sir Francis Davies, who responded, referred to the services rendered by the medical profession during the past war, and especially to the way in which the civil practitioner had forsaken everything to dedicate his services to his country. The regular medical branch of the Army was greatly the better for his inclusion. Whilst he was at the War Office he was greatly impressed by the many striking instances of gallantry shown by medical men which came before him for recognition. The President proposed "The Club," and in doing so referred to its thriving state. It possessed about 200 members, all of them medical men who had served overseas during the past war. Amongst its many advantages the greatest was that of bringing together men who had worked together on the field of battle and in overseas hospitals. The toast of "The President" was proposed by Dr. George Rae Gibson. Dr. C. E. Douglas of Cupar was elected president-elect, and Drs. W. T. Gardiner, M.C., and Pirie Watson, O.B.E., were elected to the committee in place of T. F. Dewar, C.B., and Henry Wade, C.M.G., D.S.O. The secretary is Dr. James Young, D.S.O., Edinburgh.

Ireland.

REPORTS ON WOUNDED IN DUBLIN HOSPITALS.

On behalf of certain Fellows and Licentiates of the Royal College of Surgeons, Ireland, affected by the military Order recently issued requiring them to furnish daily particulars of wounded persons under their care in hospital, a communication has been addressed to the Council of the Royal College stating that the Licentiates and Fellows of the College and the Irish profession generally would be glad for an expression of opinion by the Council regarding the military Order referred to and asking the Council to make representations to the military authority to have the Order revoked. Fellows and Licentiates of the College, and other members of the profession, have expressed strong opinions with regard to the breach of professional confidence involved in giving effect to the military Order, and for this and other reasons feel serious objection to furnishing the information required by the military authority. That authority, however, has stated that failure to comply with the Order will render the medical practitioners concerned liable to be proceeded against for an offence against the Restoration of Order in Ireland Regulations. The republican army in Ireland have countered the military Order by intimating to the doctors concerned that should they obey the Order such doctors will be treated as spies.

It was also brought to the notice of the Council that Poor Law medical officers, a large proportion of whom are Fellows and Licentiates of the Irish College, have not received any portion of their salaries, in some cases, for almost twelve months. At first sight it may seem that this condition of affairs is due to the deadlock between the Local Government Board and the local authorities, and that the trouble could be got over if the local bodies would only administer the necessary statutes, including the Malicious Injuries Amendment Act. These Acts, however, provide that all awards for malicious injuries, including those committed by the Crown forces, shall have first claim on the funds of the local authorities. In effect, this means that the entire salaries of the Poor Law medical officers, in most counties, are set aside in order to meet claims for malicious injuries. The local authorities, assuming they complied with the statutes, are asked to do what is financially impossible—namely, to raise a rate sufficient to meet ordinary expenditure as well as the amount awarded for malicious injuries, which, in many counties, would mean £2,000 rates on a farmer with £100 Poor Law valuation. As long as these conditions exist, there seems to be not the remotest chance that a Poor Law medical officer, in the majority of Irish counties, can receive his salary or any portion of it. Irish health services, under the Medical Charities Acts, would have ceased to be administered six months ago only that the Poor Law medical officers continued to give their services; they did this notwithstanding that, owing mainly to the diversion of health grants to other purposes under the recent special Acts of Parliament already referred to, their salaries were not paid.

The slender resources of the average Poor Law medical officer will not, however, permit him much longer to carry out his work on the present terms. This contingency has already been brought to the notice of the Chief Secretary, who is Minister of Health for Ireland. His reply held out no hope that there was any intention on the part of the Government to alter or amend existing legislation so that a way out of the present difficulty may be found. The result is that fully 30 per cent. out of the 50 per cent. of the population of this country who are dependent for their treatment on the Poor Law medical officers—as such—are at the present moment unprovided for as regards medical treatment. Legislation amending the recent statutes, which are responsible for the diversion of health grants and other funds from the purposes to which they were hitherto applied, is the only remedy if the necessitous one-fourth of the population of Ireland are not to be left without medical treatment of any kind.

ARRESTS OF MEDICAL MEN.

Dr. Thomas F. Higgins, F.R.C.S.I., coroner for Queen's County and medical officer of the Stradbally district, has been arrested by the Crown forces; he is over 70 years of age. His son, Dr. T. Higgins, Maryborough, has been

interned for some months without being brought before a court-martial. Dr. Ryan, Wexford, has been transferred from Waterford Gaol for internment in the Kilworth Camp, co. Cork. His wife, Mrs. Ryan, has also been arrested; the reason assigned is that she objected to a military proclamation being posted on one of her windows. The military authorities in many of the southern towns make it a practice to post proclamations on windows, holding the inhabitants responsible in case of their being torn down or effaced.

ACIDAEMIA.

At the meeting of the Ulster Medical Society on February 18th, when the President, Dr. Thomas Houston, O.B.E., occupied the chair, Sir Almoth Wright, K.B.E., C.B., F.R.S., gave an address on the pathology and treatment of acidaemia. He first mentioned a number of instances of acidaemia—a rabbit to which was administered an excess of hydrochloric acid; a guinea-pig fed on a specially restricted diet; cases where the body itself produces the acid as in diabetes, and the acidaemia in gas gangrene and in shock. When these were examined it was seen that they could be classified as (1) myogenous and (2) non-myogenous. If a muscle was deprived of its blood supply, lactic acid at once began to collect owing to the deprivation of oxygen; a local acidity was thus produced in the muscle, and this he called "acidosis"; if the blood supply returned, this lactic acid was swept into the circulation and "acidaemia" ensued; the simplest illustration of this was when an artery was ligatured; the same result followed in the application of a tourniquet or of an Esmarch's bandage; it also occurred when an animal was submerged in ice cold water; here the "somatic" circulation failed and the visceral alone remained; there was an asphyxia of muscle. If a heart failed owing to a microbic poison, or if a patient collapsed, as after wounds and exposure, or after a long operation, a similar condition was produced; among the dangers after an anaesthetic was collapse. Different animals were differently affected. Some, as the rabbit, were very susceptible; some, like the cat with its nine lives, were the reverse; no doubt human beings also varied. When a person, collapsed from injury and long exposure to cold, was brought into hospital, if the somatic circulation slowly returned, then the lactic acid was oxidized; but if the heat was brought back rapidly by artificial means and the limbs massaged, the patient was liable to develop acidaemia. A frost-bitten part is rubbed, not heated by applications. In conditions of shock, fluid introduced into the blood vessels escaped with great rapidity, whereas, if it were introduced before the onset of shock it was retained. In shock there was a polycythaemia in the capillaries, due probably to the rapid escape of the fluid, so that the heart had a heavier weight to drive. The essential point in treatment was to prevent the onset of shock—to try to anticipate it. Cohnheim had shown that the blood might be diluted many times in an animal without its rapidly escaping, so that before a long operation with an anaesthetic was attempted the alkalinity of the blood should be tested, and the operation postponed if the result were not satisfactory; then would be the time to prevent the onset of shock; medicinally, sodium lactate should be given. In cases of shock a rapid recovery had been obtained by intravenous injection of an alkali, but these patients were liable to relapse, owing probably to developing acidaemia. Cannon found that cases of gas gangrene and shock had marked acidaemia; the gangrene bacillus did not grow in alkaline muscle; it would not grow in a healthy rabbit, but if a rabbit were killed after inoculation and its body put in an incubator, rapid growth took place so that it became distended with gas. In concluding his lecture Sir Almoth urged the necessity of advancing step by step in our investigations. The *salus empiricus* was to be avoided by all true scientific followers; they must be content with the *passus scientificus*.

Dr. R. J. Johnstone, F.R.C.S. Eng., proposed a hearty vote of thanks to the lecturer; this was seconded by Dr. J. B. MacIlwaine, and passed by acclamation.

ULSTER MEDICAL SOCIETY.

At the annual dinner of the Ulster Medical Society, held in the Medical Institute, Belfast, on February 17th, when the President, Dr. Thomas Houston, O.B.E., occupied the chair, the chief guest was Sir Almoth Wright.

The toasts were "The King," proposed by the President; "The Lord Mayor and the Corporation of Belfast," proposed by Professor Lindsay, F.R.C.P.Lond., and responded to by the High Sheriff; "Our Guests," proposed by the President, who expressed the great pleasure of the society in seeing Sir Almroth once more amongst them, and their deep obligation to him for stimulating them with his keen scientific mind. He outlined some of Sir Almroth's work in typhoid prevention and, during the great war, in wound sepsis. Sir Almroth, in reply, emphasized the fallaciousness of experience and the necessity of experiment. Dr. Fleming also replied. "The Legal Profession" was given by Dr. J. S. Morrow, and acknowledged by the Recorder of Belfast and the President of the Law Society. "The President" was proposed by Dr. MacIlwaine, and Dr. Houston in his reply said that much of the success and of the excellent arrangements of the dinner were due to the editing honorary secretary, Dr. Robert Marshall, who took Dr. W. W. D. Thomson's place during the prolonged illness of the latter, who, he was glad to say, was now much better. He proposed Dr. Marshall's health, and offered him the thanks of the society. Dr. Marshall replied.

Correspondence.

SURGERY OF BREAST CANCER.

SIR,—Mr. R. H. Parry's demonstration (January 15th, p. 99) of the presence of malignant cells in the supraclavicular glands in five out of six selected cases of breast cancer is a most important fact, since the cases were specially chosen as presenting no clinical signs of supraclavicular infection.

Mr. Parry and I have, by different roads, reached the same conclusion—namely, that no operative method for breast cancer is satisfactory which does not as a routine take steps to counter infection of these glands. It might have been hoped that post-operative α -ray treatment would have proved adequate for the purpose, but experience shows that this is not the case, at any rate with present α -ray methods.

The choice appears to lie between routine removal of the supraclavicular glands as part of the primary operation, as advocated by Mr. R. H. Parry and Mr. Charles A. Morton, and the routine use of buried radium as described in my article. It will not be possible for several years to decide on the relative merits of these two methods, and it is well for the present that both should be practised. Personally, I am hopeful about the buried radium method and intend to adhere to it. In view of the striking shrinkage of obviously enlarged glands which often occurs after its use, it should be competent *a fortiori* to deal with the early microscopic stage of infection. As compared with excision it has the great advantages that it is applicable even in old or enfeebled patients, and that it does not increase shock or appreciably prolong the operation. It is, however, true, as Mr. Parry points out, that the present scarcity of radium restricts the use of the method to centres where it is available in sufficient amounts—say 100 mg.

Unless infection of the anterior mediastinal glands is secondary to infection of the supraclavicular glands, as Mr. Parry believes, both these sets of glands require to be dealt with. Now I have seen recurrence, apparently originating from the anterior mediastinal glands, in cases where no enlarged supraclavicular glands could be felt. Logically, therefore, if the supraclavicular glands are excised it seems to me that the anterior mediastinal glands should also be removed. My adhesion to the buried radium method is partly due to an unwillingness to face such an alarming, though quite possible, extension of the operation. I have cleared the anterior mediastinum in 6 cases. In 4 of these no glands—or only uninfected ones—could be found. In 2 cases infected glands were found, and both these cases subsequently died of recurrence.

Mr. Robert E. Lord's letter of January 22nd asks most pertinent questions as to α -ray dosage, which, however, should be addressed rather to radiologists and physicists than to a surgeon. Questions of quality, as well as quantity, arise. I will only record my impression that I have seen the best results in cases where deep pigmentation of the skin has been secured over a wide area.—I am, etc.,

London, W., Feb. 16th,

W. SAMPSON HANDLEY.

X-RAY RADIATION AND CANCER.

SIR,—A letter from Dr. Reginald Morton in your columns of January 29th stated that, after a recent visit to a Frauenklinik in Bavaria, he came home with the conviction that only spark coils will supply the really hard radiation which is necessary for the successful treatment of deep-seated malignant diseases; that there is only one outfit in this country capable of doing this work; and that a weak dose of α rays will stimulate the growth of malignant cells instead of killing them.

I beg to draw attention to the fact that my firm has persistently advocated the necessity of using spark coils for producing hard rays; that coils specially built to work the α -ray tubes referred to by Dr. Morton are being made in this country too; and that as long ago as 1914 we mentioned, on page 243 of our catalogue, that prominent gynaecologists have found that "a weak dose irritates and accelerates the growth of malignant cells, and only a strong dose will kill them."—I am, etc.,

London, W., Feb. 16th.

W. E. SCHALL, B.Sc.

THE POSITION OF THE ARMS IN BREECH WITH EXTENDED LEGS.

SIR,—Some of your readers may recall a recent trial in which a medical man was unsuccessfully sued for negligence because, in a case of breech with extended legs which he attended, the child was born dead.

The doctor in his deposition attributed much of the difficulty of the delivery to the fact that, in addition to the legs, the arms also were extended, and stated that in introducing his hand into the uterus to bring down the legs he found the arms already above the head, though the shoulders were high above the pelvic brim. The prosecution tried to prove that the extension of the arms was brought about by improper pulling on the trunk of the child; but the doctor stoutly stuck to his guns, although the expert witnesses called on his side—of whom I was one—were unable to support his assertion from any similar experience or knowledge of their own.

As a fact, in cases of extended legs the hand is not as a rule introduced much above the knee, and consequently there is no opportunity of ascertaining the position of the arms.

On two occasions lately when dealing with extended legs I have had to introduce my hand up to the head of the child, and in both cases the arms were by the side of or above the head. Moreover, I satisfied myself by test upon a newborn child that when the legs are in full extension the feet and calves take up so much room as necessarily to prevent the arms assuming their normal position on the chest. The practitioner may therefore take it that in every case of extended legs the arms also are abnormally placed, and as a matter of routine should be manually brought down before any attempt is made to deliver the head.

The position of the arms in "impacted breech" is not referred to, as far as I know, in any textbook, though it is obviously important from the obstetric point of view, and on occasions, as in the case I have referred to, it may acquire a medico-legal interest as well.—I am, etc.,

London, W., Feb. 16th.

VICTOR BONNEY.

VACCINE THERAPY IN REGARD TO GENERAL PRACTICE.

SIR,—May I elaborate a point in Dr. Fleming's valuable lecture published in your issue of February 19th? The discovery that pneumococci can be classified into strains by paying attention to their agglutination by serums was made independently but almost simultaneously by the American workers Drs. Dochez and Gillespie, and by Dr. (now Sir Frederick) Lister in South Africa. Lister had the great advantage of working under Sir Almroth Wright during the latter's visit to South Africa, and became adept in his methods of laboratory work. When Sir Almroth returned to England, Lister isolated pneumococci from cases of pneumonia, and found that at a certain stage the serum of a patient strongly agglutinated, and opsonized his particular pneumococcus, but not necessarily the pneumococcus derived from another patient. This furnished him with a clue.

Lister's work, which has proved of enormous economic importance to South Africa, can be studied in his papers

published by the South African Institute for Medical Research, which are to be seen in the library of the Royal Society of Medicine.—I am, etc.,

London, W., Feb. 19th.

A. R. FRIEL.

HEART-BLOCK IN DIPHTHERIA.

SIR,—I am much interested in the case of diphtheria developing heart-block reported by Dr. Clayton Allen in your issue of February 19th. The patient evidently suffered from the condition which has been described previously as "paroxysmal cardiac failure" or "vagal attacks." Although complete heart-block is unusual, yet a few cases are reported in the literature.¹ Three cases of this type are reported in my monograph, *The Circulatory Failure of Diphtheria*, and the mechanism of their production is discussed.²

During the course of some experimental work to show the effect of diphtheria toxin on cats, I on one occasion actually saw heart-block develop. The animal was dying from the effects of diphtherial intoxication when the observation was made. The concentration of its blood had risen to such an extent as to indicate the loss of about half its plasma volume. The animal was anaesthetized and the heart exposed. The muscle of both the auricles and the ventricles was seen to be in a state of fibrillation. Saline was run into the saphenous vein so as to reduce the concentration of the blood and to increase the volume in circulation. The fibrillation ceased and the heart began to beat. At first the ventricle responded to every fourth, then to every third, later to every second, and finally to every beat of the auricle. That is, there occurred progressively a 4:1, 3:1, and 2:1 heart-block. I therefore suggest that heart-block in diphtheria is not due to a specific effect of the diphtherial poison on the neuro-muscular tissue of the auriculo-ventricular bundle, nor yet to an alteration in the conducting power of the myocardial tissue as a whole from the direct action of the toxin, but is rather an effect of the lowered and hampered metabolism characteristic of the disease, which in its turn is dependent on leakage of fluid from the blood vessels, with a resulting concentration of the blood and reduction in its volume.

With regard to prognosis, it may safely be said that patients who develop attacks of paroxysmal cardiac failure of this type, treated by the methods at present available, almost invariably die. The treatment of very severe cases of diphtheria with large doses of serum will, presumably, prevent the occurrence of this most fatal complication in a proportion of instances. At Plaistow Hospital cases of the severity described in Dr. Clayton Allen's communication are given doses of from 30,000 to 90,000 units of antitoxin. Most authorities are agreed that it is inadvisable to use hot fomentations to the swollen neck, as they tend to increase the absorption of toxin. When an attack of paroxysmal cardiac failure occurs or is impending atropine hypodermically gives most relief, probably from its effect on the vagal terminals in the heart. It should, I think, be given regularly, say every four hours, to all diphtheria patients with a slow pulse (under 50) who are very ill. The foot of the bed should be raised so as to ensure the best possible circulation to the vital nerve centres. The best stimulant to use during the attacks is ether given intramuscularly. Personally, I avoid strychnine, as I think it does more harm than good.—I am, etc.,

M. ESTHER HARDING, M.D., M.R.C.P.,

Late Medical Officer, Plaistow Fever Hospital.

London, Feb. 19th.

RISKS AFTER OPERATION ON TONSILS AND ADENOIDS IN OUTDOOR CLINICS.

SIR,—I am surprised to hear that the operation for tonsils and adenoids is still done, as the writers in the present correspondence suggest, in outdoor clinics. In Bradford this has not been done to my knowledge—certainly not by myself, and, as far as I know, by any of my colleagues—for years. When I read the remarks of such authorities as Sir William Milligan, Mr. Herbert Tilley, and Dr. P. Watson-Williams I am surprised that in their respective cities more advanced arrangements have

not been made to have the operation as safe as possible and reduce the complications to a minimum. I presume that these gentlemen have the misfortune to have boards of management who pay no attention to the recommendations of their medical staffs, and are therefore not fit for the position of trust in which the subscribers to the hospitals have placed them. What is necessary for the wealthy private patient is necessary for the hospital patient.

I have been busily engaged in this type of work for close on thirty years now, and during that period have done the operation a few thousand times. Sir William Milligan says that "deaths from the anaesthetic are still too frequent, and acute otitis media, mastoiditis, glandular infection, haemorrhage, etc., are practically unknown if the child is kept in bed for two or three days." As it has been the custom here never or hardly ever to send patients home the same day as the operation, but to keep them in at least one day, I am in a position to agree that complications are rare under such conditions. I have only once seen a death from chloroform; I have never had a death from haemorrhage, though I have had several reactionary haemorrhages, which never gave further trouble than pallor for a day or two at the worst; I have had one very bad case of mastoiditis, which went on to lateral sinus thrombosis, meningitis, and death. In the last case—a private case—the patient had two days' preliminary treatment in a nursing home and was kept two days in the home afterwards, and when he was discharged all seemed well with him, but the day afterwards acute otitis media set in, with the calamitous result recorded. Apart from the death under the anaesthetic (chloroform), my worst cases have been private cases carefully attended to in good nursing homes.

I was asked many years ago to establish a clinic with sixteen beds for operative work of the ear, nose and throat, by the Bradford City Council for the school children. In Leicester there is apparently an institution of the same kind. In this little institution I always admitted the patients in the evening and operated on them at 9 o'clock in the morning. They were kept in the hospital till I came the following morning, and discharged them if fit, and if I was not satisfied with the case they were kept in longer. They had every care which any private patient could command. The results were very good. The operation done was the enucleation of the tonsils in their capsules in practically every case. In the Royal Eye and Ear Hospital I operated on the day of admission, but the patients were kept in the hospital the following night, and the results were also as good as I could expect. At the Royal Infirmary the same procedure is followed.

I cannot imagine distinguished surgeons permitting boards of management to allow such an arrangement to continue as the necessity of operating on tonsils and adenoids in an outdoor clinic, and permitting a host of crying children to be taken to a recovery room and remain there vomiting a short time, and then, when they have apparently recovered, allowing them to be taken home. I have no doubt that the complaint will be made "short of money"; then I say that any board of management which is so useless as not to be able to raise the necessary money to have such a necessary clinic founded ought to be replaced by one which can warrant the necessary trust. I am sure that if the subscribers knew the full facts plenty of money would be forthcoming.

As long as such operations as the removal of enlarged tonsils and adenoids are done in out-patient departments without the necessary indoor treatment, and as long as gentlemen accept the honour of being placed on the committees of the voluntary hospitals and take little trouble fully to discharge their duties as such, so long will the incomes of our voluntary hospitals show adverse balance sheets, and so long will socialists and others clamour for the taking over of our voluntary hospitals by the State.—I am, etc.,

Bradford, Feb. 8th.

ANDREW LITTLE.

SIR,—I have not noticed in this correspondence any mention of the fact that institutions have already been provided for the purpose of admitting children for operation and for their detention for two days subsequently.

Over 1,000 cases have thus been dealt with at the "Cyril Henry Treatment Centre" under the L.C.O.

¹ Rohmer, *Jahrb. f. Kinderheilk.*, 1913; Parkinson, *Heart*, May, 1915; Hume and Clegg, *Quart. Journ. Med.*, October, 1914; Price, *Diseases of Heart*, 1918, p. 192.

² Harding, *Circulatory Failure of Diphtheria*, Heart-block, pp. 89-91; Cases, pp. 94, 98, 99.

scheme for treatment of school children, and I think all connected with the centre are agreed that this is a much better plan in every way than the older method of sending the child home almost immediately after the operation.

There may be other similar institutions throughout the country, but probably London gave the lead in this matter.—I am, etc.,

London, S.E., Feb. 8th.

E. J. MORTON.

TREATMENT OF THE PRE-OPERATIVE STAGE OF ENLARGED PROSTATE.

SIR,—I am glad Mr. Thomson Walker agrees that there are some cases which do not require operation, and I regret I misunderstood him. However, I fancy I could bring to his notice, in another publication, this advice which he now repudiates.

I do not wish to defend the catheter, but I must say I think it is often a maligned good. True, sepsis usually follows its use, but if a little common sense were used in addition to strict cleanliness, the evils would be much fewer—at least that is my experience. If, to wit, the anterior urethra were first washed out, sterile liquid paraffin injected as a lubricant, and if after withdrawing the urine (a rubber catheter, with or without a coude whalebone stylet, is best) a mild antiseptic were allowed to flow into and out of the bladder, how few would be the organisms left in the bladder after this small additional trouble! The paraffin, as it were, imprisons them, and prevents trauma, if used in this way.

But if sepsis should follow, what then? Operate; and operation in the presence of much residual urine with sepsis often is safer than without it—the patient is auto-inoculated; not that I am defending sepsis. Take now the bugbear cancer; this usually is cancer *ab origine*, and although it often follows enlarged prostate, is this cause and effect?

I never thought there was only one cause for frequency of micturition, or that Mr. Walker advised operation for it; if so, the half of all persons over 50 would require operation. Renal diseases and scores of other things cause this symptom (for instance, "mountain dew"!).

Mr. Neve's remarks are interesting. Massage only relieves congestion, but that is a great deal; moreover, prostatitis often accompanies "enlarged prostate." Age is no bar to inflammation, and I have often seen mistakes made. Orchitic extracts are not likely to do very much good—indeed, orchidectomy was the "cure" some years ago. Gout and rheumatism, I am sure, are big factors in prostatic changes, and I should like to add that I have found "senile prostate" (a better name) common in the priesthood, amongst whom the orthodox supposable causes (infective) are not thought to be very prevalent.—I am, etc.,

London, E.C., Feb. 8th.

JAMES MACMUNN.

THE FALL IN THE TUBERCULOSIS DEATH RATE.

SIR,—The announcement of the Registrar-General that the death rate from tuberculosis fell in 1919 to a lower point than it had ever before reached has given rise to surprise and some curious comments from those who had not expected, and perhaps had not worked to attain, this satisfactory result. The writer, with countless other workers in the field of preventive medicine, has been confidently expecting this fall, and does not, like the medical correspondent of the *Times*, find it unaccountable. In a letter which you published nearly twelve months ago I maintained that the rise in the tuberculosis death rate which occurred before and during the war was due to temporary factors, including influenza, and was not the result of paternal legislation, which if it had diminished real wages, had also decreased destitution. I also ventured to prophesy that we should very soon see the deaths from tuberculosis reach a lower figure than ever. My forecast has been fulfilled earlier than I expected, and must be a cause of great satisfaction and congratulation to all those who have for many years been labouring to diminish the ravages of consumption.

General hygienic measures and a higher standard of living among the poorer classes have increased their resistance to the tubercle bacilli; notification of tuberculosis and tuberculosis dispensaries have ensured earlier

treatment of commencing cases, and sanatorium treatment and the educational steps taken by medical officers of health have taught the practice of living and sleeping in the open air and the avoidance of infection. If to these factors we add diminished alcoholism and improved workshop hygiene we hardly need look farther for the cause of the fall in tuberculosis mortality.

As one who has had to retire from the line of battle, I can only wish God-speed to those who are still in it. May their efforts continue to produce equally satisfactory results.—I am, etc.,

Montreux, Feb. 16th.

SIDNEY DAVIES,
Late M.O.H. Woolwich.

EYE-STRAIN IN CINEMATOGRAPII HALLS.

SIR,—In your issue of February 19th you state that the committee appointed by the Illuminating Engineering Society believes that cinematograph ocular discomfort arises mainly from the abnormal angle at which the eyes of spectators are directed upwards to the pictures.

In a paper published in the *British Journal of Ophthalmology* for November, 1920, I gave some personal experience gathered in a large war hospital, where we had cinematograph exhibitions from three to six times a week. The ocular discomfort I experienced was so great that often I had to leave the hall. I usually sat 45 ft. away from the screen, and so the angle of elevation in my case was small and had nothing to do with the production of the discomfort. For nearly four years I had the subject occasionally under consideration, and came to the conclusion that the locality of the discomfort is in the retina and that it is caused by central or uneven illumination of the retina while the eye is in a condition of dark adaptation. If the light on the screen is very bright or bright in patches the peculiarity is exaggerated and the discomfort increased.—I am, etc.,

Glasgow, Feb. 19th.

J. ALEXANDER WILSON.

THE COLLECTIVE OPINION OF THE PROFESSION.

SIR,—As a non-member of the Association, may I venture to criticize the construction of the body which the British Medical Association proposes as "really representative of all the organized medical profession, both generally and sectionally"? (SUPPLEMENT, February 19th, p. 42.)

If I understand aright, Dr. Addison desired a body so far representative that he would not be worried by deputations from other bodies each capable of expressing opinions adverse to the policy of the British Medical Association and each able to influence a considerable body of opinion. Since I was present when Dr. Addison expressed his desires, there is some warrant for supposing that I am correct in so understanding him. There are two bodies to which no reference is made by the British Medical Association, each of which has a considerable number of members and each of which is in a position to influence opinion outside its own ranks by its journal or by pamphlets, etc. In other words, these two bodies have sufficient funds and sufficient membership to be quite definite factors in medical opinion. I refer to the Medico-Political Union and the National Medical Union.

These bodies are not mentioned in the British Medical Association Memorandum, and, since their existence is well known, one can only conclude that the omission is deliberate. It might almost be construed as a slight. There is also the Federation of Medical and Allied Societies, and this body is claiming that Dr. Addison will recognize no body which does not include representatives of the federation. This claim is made quite explicitly, and surely merits the attention of the British Medical Association, however much or little it may itself approve of the federation's constitution.

With these three bodies neither mentioned nor invited to assist the British Medical Association, it should be patent to all that we have made no greater approach to professional unity than obtained before. Why, then, was the Memorandum issued? As a non-member I am very sure that neither my medico-political associates nor myself have any representation therein. Not being children, we shall see to it that Dr. Addison is informed that we were not even invited to agree. We shall then have arrived in the *status quo ante*, after wasting some months in getting there.

Is there no statesman in the British Medical Association big enough to rise above the chance of slighting his opponents? I venture to think that the profession requires a statesman now more than ever, a man at least big enough to put the general welfare before the opportunity of a ponderous snub. May we know the names of the statesmen who produced this Memorandum in the name of your Association?—I am, etc.,

Sevenoaks, Feb. 19th.

GORDON WARD.

The Memorandum in question was discussed and approved by the Council of the British Medical Association at its meeting on February 16th.

THE NAVAL MEDICAL SERVICE.

Sir,—The question of reform in the Naval Medical Service has been discussed freely by officers who held temporary commissions during the war. I send you a few of the reasons which may be contributory to the comparative failure of the service to augment its numbers from our very considerable numerical strength. The following statements were put down in 1919 after a three years' experience in a leading naval hospital.

There was an absence of a sufficient number of senior men with the capacity for teaching, and this, together with a complete absence of registrars, proved serious to the large body of recently qualified officers, many of whom had not held a house appointment. Registrars have been found to be part and parcel of the efficiency of civilian hospitals. The senior officers of hospital sections were in some cases quite innocent of modern medical knowledge, and often they appeared to be overburdened with paper work. In neither case were they to blame. The war has produced specialists in certain departments, but even as late as 1919 the Medical Department at the Admiralty declared, so I am informed, that the navy had no use for a neurologist in peace time.

The fact that medical officers retained their wards for very brief periods in some cases was due no doubt to the constant changes in personnel, but it resulted in many patients having as many as four and six medical attendants in a week. It was the exception for a patient needing treatment at night to receive it from a doctor who had seen him before.

Many patients, trained men, were invalided with diagnoses little short of grotesque on account of a lack of proper application of medical knowledge, and this professional flippancy was made to take an exaggerated form by reason of the multiplicity of naval medical signatures which the papers carried. The system of policing and patrol as witnessed in hospital gained few advocates from our number.

The conviction was forced upon some of us that in the service a habit can be acquired fairly readily of placing chances of promotion before medical duties which involved diagnostic and prognostic responsibility. This habit appeared to be due chiefly to the obvious difficulties under which the duties of fairly senior officers in particular had to be carried out. A career seemed to be in least danger to the officer who tried to make sure that he did nothing which could be proved wrong: in other words, a premium was placed upon a professional incapacity to face all and every medical problem. Happenings quoted from the working of the mental department have helped to support this conviction. It was common for ratings who were obviously sane on admission to be required to spend one or more days and nights in the asylum because, months before may be, they suffered from a mental disability, however transient. Once a diagnosis of mental disease was given in the service it stayed with the patient from hospital to hospital, diluted, perhaps, *en route* with the statement of the doctor who caused the diagnosis to be perpetuated that he "observed no evidence of mental disease." Similarly with cases of epilepsy and heart disease, so called.

A boy, aged 16½, was successfully invited by a senior officer to spend his first night at any rate in the asylum. The officer of the department did not see the lad until the next day, and he then found that the patient had been completely cured for three months past of a temporary mental confusion following "influenza" at Simonstown, and that he had enjoyed complete liberty during this period. Immediate transference to a medical ward was insisted upon, in spite of the statement that there was no vacancy. Nevertheless, the boy was required, in order to obtain his dinner, to return to the asylum for the purpose on this day.

There was but one ward for cases under observation and for those already certified insane. Several sane patients who were unable by reason of disease to express their thoughts in coherent speech, aphasias, were passed into the asylum on admission, in accordance with the principles of panic. Yet the navy has no place for a neurologist in peace time!

Another memory is that of all newly admitted ratings who brought with them a report that their blood serum gave a positive Wassermann reaction being swept into the venereal wards. For many months the tabetics and the owners of chancres, the hemiplegics, and the victims of urethral "strain" were apt to occupy adjacent beds, but this arrangement appeared to be due to the enthusiasm of a commissioned ward master rather than to the wishes of any medical officer.

Much good work was done by overworked and conscientious officers in the face of considerable difficulty, and certainly the writer will never forget the exceptional kindness which all temporary officers received at the hands of the permanent service, but in hospital, at any rate, there was something wrong with the machinery of medicine, and it is the recollection of it which prevents some of us from recommending wholeheartedly to medical students the Naval Medical Service. All of us would be proud of an opportunity to help this branch to be a completely worthy member of the finest service in the world, and it is on this account that this letter is written. I enclose my card.—I am, etc.,

Harley Street, W., Feb. 19th.

"M.D."

MILITARY MEDICAL HISTORY.

Sir,—I was extremely interested in Major-General Evatt's letter suggesting the appointment of a professor of military medical history. The study of the medical side of past wars is both fascinating and instructive. Personally, I have always been interested in military history, and in reading over the memoirs and biographies of officers and men it has often struck me what a wealth of material relating to military medicine is hidden away among the leaves of these books. This material unearthed and sifted would surely prove instructive and of value to all officers of the R.A.M.C. What vivid glimpses of army medical administration in past wars we get in some of these memoirs! To read of the veritable charnel houses, misnamed hospitals, in Napoleon's Russian campaign, and of the state of some of our base hospitals, such as Belem and Celorico in the Peninsula, makes one realize what vast strides have been made in the Army Medical Services. In those days, and even down to the "fifties" and later, for a man to be sent to hospital was practically to be sentenced to death. What a change to our magnificently equipped hospitals in France and Flanders in the great war!

Yet the individual regimental surgeon is always spoken of with admiration. It is the Administrative Department which is nearly always at fault. The regimental surgeon carries on in the face of tremendous difficulties and dangers. He is always cheery and bright, and sometimes, when all the other officers are struck down, he leaves his wounded for a time and takes command himself. Who is there but can admire the steadfast courage and unselfish devotion of such men as Joseph Fayrer in the Residency at Lucknow, Surgeon Kelly at Cabul in '79, Dr. Philip Frank who tied the carotid under fire at Balan in '70 (a knightly soul who I was privileged to know), and Martin Leake, who won the V.C. with bar!

There are many lessons to be learned from this last great war. Though the medical arrangements in the western theatre of the war were all that could be desired, yet in some of the various "side shows" these arrangements were anything but satisfactory. The lessons of past wars seem to have been forgotten in many instances. The medical history of the great war should prove of great value to the future generation of army medical officers. — I am, etc.,

RUSSELL V. STEELE,

Captain Late R.A.M.C.

D. Vizen, Feb. 12th.

THE PREVENTION OF VENEREAL DISEASE.

Sir,—The letter of Dr. Gilford, of Reading, gives one great pleasure. Here is someone at last who has gone to the root of the sexual evils which abound to-day.

Dr. Gilford has attacked the proper quarter, and that is

the parental upbringing of the young. Every young man and woman ought to be educated at home by the parents in self-respect with regard to bodies as well as brains. Until that is done, and the young understand for what their sexual functions are, the innocent future generations will continue to be tainted when born as is the case to-day.

When we hear of male medical students in the common-room of a London college stating that it is not possible for men to remain without sexual intercourse until marriage, it is about time we had such letters as that of Dr. Gilford brought well to the front.—I am, etc.,

London, E., Feb. 13th.

E. McHARDY, M.B., Ch.B.

Medico-Legal.

OFFENCES UNDER THE MEDICAL ACTS.

IN our issue of February 5th we drew attention to a woman calling herself Margaret Crawford (or Margaret de Lancy Williams) whose arrest was sought on a warrant by the police for alleged offences against the Medical Acts, 1858. This woman was arrested in Dublin on February 10th, and brought before Mr. D'Eyncourt at Marylebone Police Court on February 18th to answer four summonses preferred by the Medical Defence Union, Ltd., of falsely pretending to be a general medical practitioner in August and September last, and of falsely using the title of Bachelor of Medicine on three death certificates. The accused pleaded guilty and was fined £20, with five guineas costs, for each of the offences.

Universities and Colleges.

UNIVERSITY OF CAMBRIDGE.

Diploma in Medical Radiology and Electrology.

ON the recommendation of the Committee on Medical Radiology and Electrology the diploma in medical radiology and electrology has been granted to J. E. A. Lynham, M.D., A. E. H. Pinch, F.R.C.S., W. J. Turrell, M.D., A. E. Barclay, M.D., and F. Herniman-Johnson, M.D.

At a congregation held on February 18th the following degrees were conferred:

LL.D. (*Honoris causa*).—Dr. A. Calmette (subdirector of the Institut Pasteur), Sir Patrick Manson, G.C.M.G.

M.S.—O. G. Morgan.

M.B., B.Ch. G. A. Harrison.

B.Sc.—Leslie S. Gathergood.

UNIVERSITY OF LONDON.

A MEETING of the Senate was held on February 16th.

The Prince of Wales.—The Vice-Chancellor (Dr. Russell Wells) stated that the Prince of Wales would receive the honorary degrees of Master of Commerce and Doctor of Science on May 5th, and had promised to attend the graduation dinner on that evening. The Guildhall has been placed at the disposal of the University for this purpose by the Lord Mayor and Corporation, and the Lord Mayor has accepted an invitation to be present.

Professor of Obstetrics, London School of Medicine for Women.—Miss Anne Louise McIlroy, O.B.E., M.D., Ch.B., D.Sc.Glasg., was appointed to the university chair of obstetrics and gynaecology tenable at the London School of Medicine for Women. Miss McIlroy was educated at the Universities of Glasgow, London, Berlin, Vienna, and Paris. She has held the appointments of assistant surgeon at the Glasgow Female Lock Hospital, district obstetric physician in charge of the West End Branch of the Glasgow Royal Maternity Hospital, assistant gynaecological surgeon at the Royal Samaritan Hospital, Glasgow, and senior assistant to the Muirhead Professor of Obstetrics and Gynaecology at the University of Glasgow. From 1915 to 1919 she was surgeon in charge of the Giron and Newnham Unit of the Scottish Women's Hospitals for Foreign Service, which was stationed at Salonica and Belgrade. Since 1919 she has been gynaecological specialist in the 82nd General Hospital at Constantinople, in which she acted as surgical specialist during the absence of the senior surgeon. As professor she will be director of the Obstetrical and Gynaecological Unit at the Royal Free Hospital, to which the London School of Medicine for Women is attached.

Chair of Embryology.—Professor James Peter Hill, D.Sc.Edin., F.R.S., was appointed to the university chair of embryology tenable at University College. In 1892 he was appointed demonstrator in biology, and in 1904 lecturer on embryology, in the University of Sydney; and since 1906 he has held the Jodrell chair of zoology and comparative anatomy at University College.

Graham Scholarship in Pathology.—The Graham Legacy Committee reported that they had appointed Mr. V. R. Khanolkar, M.B., B.S., B.Sc., to the Graham scholarship in pathology for two years from April 1st, 1921. The value of the scholarship is £400 a year. Since October last Mr. Khanolkar has been assistant bacteriologist in University College Hospital. He has had considerable experience both as a teacher and as an investigator, and the proposed subject of his research is "Focal activity of the kidneys."

UNIVERSITY OF BRISTOL.

THE following candidates have been approved at the examinations indicated:

M.D.—A. R. Heber.

FINAL M.B., Ch.B.—*Part II (Completing Examination)*: W. H. Royal, Marjorie Wadsworth (with first-class honours). *Part I Only (including Forensic Medicine and Toxicology)*: W. A. Jackman, P. Phillips. *Part I Only*: Phyllis Beames, M. Critchley, J. R. Duerden, Winifred G. Nott, J. A. Prichard, W. K. A. Richards, Victoria S. Tryon.

D.P.H.—*Part II (Completing Examination)*: F. V. Cant, A. D. Fraser, G. C. Williams.

Obituary.

WILLIAM ODLING, M.B., F.R.S.

Late Waynflete Professor of Chemistry at Oxford.

PROFESSOR WILLIAM ODLING, who died at his residence in Oxford on February 18th, was 91 years of age, and had been Waynflete professor of chemistry in the University of Oxford for forty years; he succeeded Sir Benjamin Brodie, the first holder of the chair, in 1872, and only resigned in 1912. He was the son of a medical practitioner in Southwark, received his medical education at Guy's Hospital, and graduated M.B.Lond. in 1851. He was elected a Fellow of the Royal College of Physicians of London in 1859, during the presidency of Dr. Thomas Mayo, and was its senior Fellow at the time of his death. He never practised medicine, however, but devoted himself entirely to chemistry, having been appointed director of the chemical laboratory in Guy's Hospital at the age of 21. In 1863 he became lecturer in the subject at St. Bartholomew's Hospital Medical School, and five years afterwards succeeded Edward Frankland as Fullerian professor of chemistry at the Royal Institution. In his early days he wrote a number of papers on theoretical considerations regarding the constitution of organic bodies, and later gave much attention to practical questions, such as the purification of rivers, the analysis of drinking water, and the chemistry of bread-making; he wrote a number of textbooks which were popular in their day, but during the later part of his life he ceased to do much in the way either of research or writing. He married, in 1872, the daughter of Mr. Alfred Smees, F.R.S., and leaves three sons, one of them a lecturer in the University of Leeds.

JAMES HUNTER, F.R.C.S., F.R.C.P. EDIN., F.R.S. EDIN.,

Liberton, Midlothian.

DR. JAMES HUNTER, who died suddenly in Edinburgh on February 14th, was known to many generations of students both inside and outside the University of Edinburgh as a teacher and an examiner in physiology. He was elected to the Fellowship of the Royal College of Surgeons of Edinburgh forty-three years ago, and soon came to devote himself with zeal to physiology, giving lectures thereon in the Minto House School of Medicine. Later he acted as examiner in that subject and in biology for the Triple Qualification of the Royal Colleges of Edinburgh and Glasgow. He was in no sense a one-subject man, for his enthusiasm extended outside of medicine and invaded astronomy and geology and theology, a fact which sometimes made a curious appearance in his oral examining in physiology and biology. He was a devotee of science in many of her departments, and at one time took a great interest in the work of the Royal Society of Edinburgh. Although retired from active teaching some years ago Dr. Hunter courageously returned to it for a short period during the war when Edinburgh was sorely depleted of her extramural staff. He moved quietly about amongst his fellows, seeking no honours, but always doing his daily work in an effective and unostentatious fashion, and his death will leave a blank in the circle who knew and loved him well.

MR. ALEXANDER DUNCAN, B.A., LL.D., secretary and librarian of the Royal Faculty of Physicians and Surgeons, Glasgow, died on February 14th. He had held the appointment for over fifty-five years, and had a most extensive and profound knowledge of medical literature. He was born at Muckhart, near Dollar, graduated B.A.Lond., and for a time was a schoolmaster in Kirkintilloch. In 1865 he was appointed secretary and treasurer to the Faculty of Physicians and Surgeons in Glasgow. By compiling and publishing catalogues of the library he facilitated greatly the work of medical research,

and he prepared a history of the medical profession in the West of Scotland, entitled *Memorials of the Faculty of Physicians and Surgeons of Glasgow; with a Sketch of the Rise and Progress of the Glasgow Medical School and of the Medical Profession in the West of Scotland*. He received the honorary degree of LL.D. from Glasgow University in 1898.

Medical News.

ON February 21st the Council Club of the Royal Society of Medicine entertained Sir Dawson Williams, Sir Charles Ryall, and Sir Maurice Craig at dinner. The President of the Society, Sir John Bland-Sutton, was in the chair, and among those present were Sir R. Hill, K.C.M.G., Medical Director-General R.N., Sir John Goodwin, K.C.B., D.G.A.M.S., Sir Arbuthnot Lane, Bt., Sir J. Dundas Grant, Dr. R. A. Gibbons, and Mrs. Scharlieb, M.D.

A CONFERENCE on industrial welfare, arranged by the society bearing that name, will be held at the Mansion House on March 2nd. The Lord Mayor will preside, and among the speakers will be the Duke of York, the Home Secretary, the President of the Board of Education, and the Right. Hon. J. R. Clynes, M.P.

AT a meeting of the Radnorshire Panel Committee held at Llandrindod Wells on February 18th, Dr. Harding of New Radnor (Chairman of the Radnorshire Panel Committee and Chairman of the Radnorshire Insurance Committee) was presented with a silver salver inscribed as follows: "Presented to Dr. R. Harding on his marriage, December 1st, 1920, by the panel practitioners of Radnorshire, as a small token of their appreciation of his services in connexion with national health insurance." The presentation was made by Dr. J. Murray of Llandrindod Wells, who in the course of his remarks made reference to the untiring energy and determination with which Dr. Harding had fought in the interests of rural practitioners, especially in regard to extra mileage.

DR. GUSTAV MONOD-WALTER of Vichy is at present in London to discuss with the profession here the possibility of establishing some practical organization for encouraging closer co-operation between the profession in the two countries. Some time ago independent members of the profession in France formed a propaganda section; it has now been enlarged by the addition of representatives of the teachers of the medical schools in France, and is known as the Association pour le Développement des Relations Médicales (A.D.R.M.). This body, which works under the auspices of the Faculté de Médecine, is prepared to offer the advantages of its organization to British medical practitioners visiting Paris in return for similar advantages to be placed at the disposal of French doctors coming to this country. The suggestion is under the consideration of the Fellowship of Medicine.

THE foundation stone of a new home for the nurses of St. Bartholomew's Hospital was laid by the Queen on February 17th. The nursing staff has hitherto been housed in a number of old buildings on the site of which the new building is to be put up; the first of the four blocks which have been planned is now building, and the others will be erected as funds permit. The blocks will be connected on each floor by enclosed bridges, and each floor of each block is to be self-contained and capable of being isolated entirely in such an event as fire or infection. Separate bedroom accommodation will be provided for the whole of the nursing and female domestic staff, offices for the matron and her assistants, various common rooms and dining halls, sick bay wards for twenty-five nurses, a lecture theatre, a library, and an examination room. The Queen was received by the Prince of Wales, president of the hospital, who presented to Her Majesty the hospital treasurer and almoners and representatives of the medical and nursing staffs. Prayer was offered by the Bishop of London, and the Prince then read an address which stated that the governors had long recognized the need of improved accommodation for the nursing staff, and were grateful that, thanks to public munificence, they were now in a position to erect the first block of a new home which would ensure healthy conditions of housing, comfort, convenience, and economy of administration. The Queen then handed the trowel and mallet, and the stone was well and truly laid. The Prince of Wales, in expressing the thanks of the governors, mentioned that "Bart's" had lately received some munificent donations; one of the individual donations was of £25,000, and another of £10,000.

DR. ARCHIBALD LEITCH has been appointed Director of the Cancer Hospital Research Institute.

A THIRD course of lectures and practical courses of instruction for a diploma of psychological medicine will be given this year at the Maudsley Hospital. The first part, by Sir Frederick Mott, F.R.S., Dr. Golla, and Dr. Devine, will begin in the first week of April; the second will be held in October. Further particulars can be obtained from the Fellowship of Medicine, 1, Wimpole Street, W.1, which will issue tickets. The fee for the full course is 15 guineas; for each part separately, 10 guineas.

POST-GRADUATE courses in dermatology and venereal diseases will be given this spring at the Hôpital Saint-Louis, Paris, under the direction of Professor Jeanselme. The course in dermatology will begin on April 8th and conclude on May 28th; it will include lectures and clinical demonstrations, including a special course on ringworm by Drs. Sabouraud and Noiré. The course in venereal diseases will begin on May 30th and end on July 7th. The fee for each course is 150 francs. All further particulars can be obtained from M. Marec Bloch, Chef de Laboratoire à la Faculté, 40, rue Bichat (10^e), Hôpital Saint-Louis.

A COURSE of four public lectures on the history of plant declination, a subject of importance in the history of medicine, will be given during March in the Botany Department of University College, London. The first two, on the art of the ancient empires and the dark and middle ages, will be delivered by Dr. Charles Singer, and the other two, bringing the subject down to recent times, by Dr. Agnes Arber. The lectures are given on Wednesdays at 5 p.m., beginning on March 2nd, and are open to the public without fee.

A COURSE of twelve lecture-demonstrations on gonorrhoea for senior students of the hospital and medical practitioners will be given at the London Hospital, beginning on March 1st, at 4.30 p.m., by the chief assistants to the Genito-Urinary Department. Mr. Clarkson's demonstrations on the male will be given on Tuesdays and Thursdays, and Dr. Simpson's on women on Wednesdays and Fridays. Particulars can be obtained from the Dean.

DR. A. E. BARCLAY, medical officer of the X-Ray and Electrical Department, Manchester Royal Infirmary, informs us that a series of seven plaster models made from X-ray observations and showing the normal stomach and the effect of posture upon its shape have been placed on exhibition at the Royal College of Surgeons.

THE 1921 report of the Officers' Families Fund covers a period of nearly two years, and shows that the administration of this important Fund, which relieves many hundreds of necessitous cases, is being well and economically carried out; the work has naturally diminished somewhat during the last two years, and the institution of the Officers' Association, with which the Fund has a working arrangement, has also relieved it in some measure.

OF the twenty-one successful candidates at the recent examination of the Sanitary Inspectors' Examination Board ten received instruction at the Battersea Polytechnic, six at the National Health Society, three at the Royal Sanitary Institute, and one from the Hackney Institute; the remaining candidate was in office.

ON the recommendation of the Minister of Health, the King has been pleased to appoint Mrs. Ellen Frances Pinsent to be a Commissioner of the Board of Control, to fill the vacancy caused by the retirement of Miss Mary Dendy.

THE Nurses Registration Act, 1919, empowered the General Nursing Council for England and Wales to make rules with respect, among other matters, to the uniform or badge which may be worn by nurses registered under the Act. Neither uniform nor badge are compulsory, but the Act provides that any unauthorized person using the uniform or badge shall be liable on a summary conviction to a fine not exceeding £10 for the first offence, and £50 for any subsequent offence. The General Nursing Council has now issued a notice inviting expressions of opinion from members of the nursing profession as to the design of outdoor and indoor uniforms, and especially as to whether the usual cloak and bonnet for outdoor wear will be preferred, or a coat and hat. Communications should be addressed to the Registrar, General Nursing Council for England and Wales, Room 104, third floor, Ministry of Health, Whitehall, S.W.1.

It is announced that the University of Edinburgh *Roll of Honour, 1911-1919*, edited by Major J. E. Mackenzie, with 845 portraits, is in the press, and will shortly be published by Messrs. Oliver and Boyd.

The Lord President of the Council has appointed an Interdepartmental Committee on Patents to consider the methods of dealing with inventions made by workers aided or maintained from public funds, whether such workers be engaged as research workers or in some other technical capacity. The Committee is to outline a scheme to give a fair reward to the inventor, and thus encourage further effort while protecting the national interest. Among the members of the Committee are Dr. H. H. Dale, F.R.S., head of the Department of Biochemistry and Pharmacology of the Medical Research Council. Communications with regard to the work of the Committee should be addressed to Mr. A. Abbott, 16 and 18, Old Queen Street, Westminster, S.W.1.

WHAT is stated to be the largest collection of British manufactures ever gathered together has been opened for a fortnight at the White City, London, in the shape of the British Industries Fair, arranged by the Department of Overseas Trade. Similar fairs have been opened in Birmingham and Glasgow. The fair brings within the space of forty acres or so a comprehensive exhibit of British industry and invention. The two sections which are most likely to interest any medical visitor are those devoted to chemical preparations and scientific instruments. In each of these a little market town of some thirty separate displays has been assembled. The exhibition of chemical preparations is of a very miscellaneous character, although it has some attractive features, but the other section will be the greater surprise to those who are aware how dependent we have been in the past upon foreign enterprise. It is difficult to think of anything in the way of scientific instruments and laboratory equipment which is not represented by British-made articles, and the exhibit of optical glass and of glass-ware generally is as good an illustration as anyone could desire of British genius and craftsmanship.

THE issue of *Nature* for February 17th was a special number containing a series of articles on the principle of relativity, by Einstein, Lorentz, Sir Oliver Lodge, and others, including one by E. Cunningham tracing the long history of the idea.

Letters, Notes, and Answers.

As, owing to printing difficulties, the JOURNAL must be sent to press earlier than hitherto, it is essential that communications intended for the current issue should be received by the first post on Tuesday, and lengthy documents on Monday.

In order to avoid delay, it is particularly requested that ALL letters on the editorial business of the JOURNAL be addressed to the Editor at the Office of the JOURNAL.

THE postal address of the BRITISH MEDICAL ASSOCIATION and BRITISH MEDICAL JOURNAL is 429, Strand, London, W.C.2. The telegraphic addresses are:

1. EDITOR OF THE BRITISH MEDICAL JOURNAL, *Atitology, Westminster, London*; telephone, 2630, Gerrard.

2. FINANCIAL SECRETARY AND BUSINESS MANAGER (Advertisements, etc.), *Artedate, Westminster, London*; telephone, 2630, Gerrard.

3. MEDICAL SECRETARY, *Medisecra, Westminster, London*; telephone, 2630, Gerrard. The address of the Irish Office of the British Medical Association is 16, South Frederick Street, Dublin (telegrams: *Bacillus, Dublin*; telephone, 4737, Dublin), and of the Scottish Office, 6, Rutland Square, Edinburgh (telegrams: *Associate, Edinburgh*; telephone, 4361, Central).

QUERIES AND ANSWERS.

"M.B." asks for suggestions regarding the treatment of a patient, aged 60, who suffers from intense itching on both legs, below the knee, when warm in bed. The patient has a good appetite, no varicose veins, no sugar in the urine, and has a very slight patch of eczema—so slight as to be hardly noticeable—on one leg.

INCOME TAX.

"MEDOC" who has changed his address, asks (1) whether he should apply for a declaration form or wait until the authorities supply one on their own initiative; (2) can he deduct the cost of travelling from his residence to his consulting room? (3) how does the three years' average apply?

"Medoc" has presumably commenced an entirely new consulting practice. Legally he is under an obligation to render a statement of his liability whether it is specifically applied for or not; it is also preferable to deferring the matter for two or three years and then having to make good arrears of income tax. The cost of traveling would not be admissible unless the practice is carried on at the residence as well as at the consulting rooms. The army emoluments cannot be averaged with professional profits, and the liability will be determined for the first year on the

earnings of that year, for the second year on the same amount, for the third year on the average of the first two years, and thereafter on the average of the three previous years' earnings. This is, of course, subject to any change in the law as to the average, and to the fact that as the law stands there is a proviso that during the first four years the "average" assessment can in each year be reduced to the amount of that year's profits.

LETTERS, NOTES, ETC.

CURE OF HAEMORRHOIDS WITHOUT OPERATION.

DR. A. WITHERS GREEN writes: All the suggestions made in the article at p. 265 of the JOURNAL of February 19th were dictated to me by my own common sense "years and years ago." I always use zinc oxide or zinc oxide with starch powder, with no atom of that common criminal boric acid. Ladies like a white powder better than a pink calamine. They also like calomel ointment in mild cases instead of that dirty ung. gallae c. opio. I would add: Grease the faeces internally by taking olive oil or liquid paraffin by the mouth; grease the anus before going to stool; use no paper, sponge; with cold water, and assume the horizontal position at once with a large cushion under the buttocks, with shoulders not raised, but on the flat.

LUMBAR PUNCTURE IN ACUTE DISEASE.

MR. H. V. DREW, F.R.C.S. (Broadstairs), in the course of a letter, writes: I have in previous communications shown that disease manifestations are primarily due to the influence of toxins on the central nerve centres controlling all the vital processes, and I believe that reducing intraspinal pressure, and therefore absorption of toxins in acute diseases accompanied by grave symptoms, will save many lives and produce a revolution in medical practice. During the influenza-pneumonia epidemics of 1918 I appealed to the Army Medical Service to test my proposal, but it was not done. It follows from my formula above that we have an opportunity afforded for (1) analysing the toxins of disease as manifested in the cerebro-spinal fluid; (2) a simple method of reducing pressure injurious to the higher vital control centres, which in its turn increases absorption of the injurious toxins, causing headache, delirium, and all the other nervous symptoms common to acute diseases, which can only be explained by their influence on the central nervous system; and (3) a means of treating directly, not only symptoms, but diseases at the source, by relieving intraspinal pressure, and by direct injection of suitable remedies, medicinal or antitoxin. Since I first enunciated these views I know of such diverse cases as puerperal eclampsia, pneumonia, and status epilepticus, which recovered under the method suggested. I can recall many fatal cases of pneumonia and other acute diseases in which acute nervous symptoms were present, and to which no relief could be given; a simple tapping of the theca would have brought about immediate relief and ultimate recovery.

In regard to this subject attention may be drawn to paragraph 104 of the Epitome (January 22nd, 1921).

VACANCIES.

NOTIFICATIONS of offices vacant in universities, medical colleges, and of vacant resident and other appointments at hospitals, will be found at pages 34, 35, 38, 39, 40, and 41 of our advertisement columns, and advertisements as to partnerships, assistantships, and locum tenencies at pages 36 and 37.

THE appointment of a medical referee under the Workmen's Compensation Act, 1906, for the Sherriffdom of the Lothians and Peebles is vacant. Applications to the Private Secretary, Scottish Office, Whitehall, S.W.1, by March 16th.

THE following vacant appointments of certifying factory surgeons are announced: Westbury (Salop), Allendale (Northumberland), Colne (Lancaster), Eccles (Lancaster), Hammersmith and Paddington (London), Kirkby Lonsdale (Westmorland), Shap (Westmorland).

SCALE OF CHARGES FOR ADVERTISEMENTS IN THE BRITISH MEDICAL JOURNAL.

	£	s.	d.
Six lines and under	0	9	0
Each additional line	0	1	6
Whole single column (three columns to page)	7	10	0
Half single column	3	15	0
Half page	10	0	0
Whole page	20	0	0

An average line contains six words.

All remittances by Post Office Orders must be made payable to the British Medical Association at the General Post Office, London. No responsibility will be accepted for any such remittance not so safeguarded.

Advertisements should be delivered, addressed to the Manager, 429, Strand, London, not later than the first post on Tuesday morning preceding publication, and, if not paid for at the time, should be accompanied by a reference.

NOTE.—It is against the rules of the Post Office to receive post-restante letters addressed either in initials or numbers.

A British Medical Association Lecture
ON
THE INFLUENCE OF THE WAR ON
THE MODERN TREATMENT OF
FRACTURES.*

BY

HENRY WADE, C.M.G., D.S.O., M.D., F.R.C.S. Ed.,
EDINBURGH.

THE experience which so many doctors gained when serving with the army in the field has not only modified profoundly the method of treatment of cases of fracture and other injuries, but has also changed in a marked degree our outlook on many of the general problems that confront the medical profession.

The first and most important lesson learned was that the treatment of the injured was never the concern of one single individual. It was always the joint responsibility of a team, each member of which loyally co-operated to contribute his share towards obtaining the most painless and most speedy cure of the sufferer. The responsibility for the care of the wounded man commenced on the firing step or even in the field in front of it where the soldier fell, and continued up to the time of his final cure. Let us trace his progress through the various stages of his treatment and see what lessons, useful to civil practice, we can learn thereby.

The regimental medical officer was the family doctor of his battalion. His duties, as regards the care of the wounded, commenced long before his battalion went into action or even entered the line. When on home service there was detailed to him a group of men selected usually by their company commander or squadron leader as unlikely to make efficient soldiers. These were appointed battalion stretcher-bearers and wore the S.B. brassard on their arms. At this stage in their existence they were looked on by the combatant ranks as a necessary nuisance, which unfortunately decreased further the bayonet strength of the firing line. But later the actual experience of warfare altered this opinion, and the quiet heroism they displayed, and only too often the heavy casualties they endured, made them the most respected and admired soldiers in their battalion.

The value of the instructions imparted by the regimental medical officer to his pupils was at first frequently not very apparent when it came to be tried in actual practice, but, in the later stages of the war, some of these bearers became so expert in applying dressings to recent wounds, and in treating such serious injuries as fractured femurs, that their service to the battalion was of the very greatest value. The neatness, expedition and comfort with which they carried out this treatment few medical men could equal.

When confronted with the problem of the treatment of the recently wounded, the duties of the regimental medical officer were clearly defined. They were: to cover the wound to prevent it being further contaminated, to relieve pain, to arrest hæmorrhage, to provide rapid and comfortable transport, and to minimize shock.

The success which attended their efforts to minimize the shock following a serious wound was found to depend to a great extent upon the thoroughness with which pain was relieved, hæmorrhage arrested, and rapid and comfortable transport provided. The history of the treatment of gunshot fractures of the femur as it evolved during the war illustrates this.

FRACTURED FEMUR: THE THOMAS SPLINT.

In the earliest stages of the war the battalion medical officer relied almost entirely on the application of a rifle splint to immobilize a fractured femur. To apply this correctly is difficult, and when applied it has many disadvantages. The patient is difficult to transport; the result is on the whole unsatisfactory. When he came under the care of the field ambulance at its advanced dressing station, or farther back, the rifle splint was removed and a Liston's long splint substituted, but little

improvement was obtained, and latterly the use of this splint was generally emphatically condemned.

The mortality that attended cases of fractured femurs was at this period appallingly high. Statistics, collected over part of the army area in France in 1916 by Colonel Sir H. M. W. Gray, led him to estimate the total mortality at nearly 80 per cent., a large portion of it being at the casualty clearing station or on the way there.

The battle of Arras, which took place in April, 1917, was about to be fought, and Colonel Gray, being convinced that a great saving in life might be effected in these cases by the use of the Thomas splint as a routine method of fixation, instituted a well organized educational campaign through the medical men of the Third Army to achieve this object. With the knowledge and approval of General Allenby this was carried out. A good supply of Thomas splints was distributed to the field ambulance, and even farther forward, and orderlies were trained to put these on. The result was that cases, instead of arriving at the casualty clearing stations almost moribund from shock and exhaustion, came in well enough to stand immediate operation, and the death rate in the clearing station of one army actually fell from nearly 50 per cent. in 1916 to 15.6 per cent. in 1917.

At that period I was serving as consulting surgeon with the army in Palestine. We knew of the Thomas splint, and were advocating its more widespread employment with partial success, but soon thereafter there arrived in the East the greatest benefactor the surgery of the army there received—General Allenby took over command. At one of his earliest conferences, I am informed, when the medical organization for his forthcoming offensive was being reviewed, he said that he believed there was a splint known as the Thomas splint, which was invaluable in cases of gunshot wounds of the thigh or knee, and it was his intention and desire that there should be one such splint available for every soldier receiving a wound in this region. The driving power behind this decision was magical. The central splint factory in Alexandria, which at the time was completing an order for 2,500, received instructions to make 5,000. Every general hospital, stationary hospital, casualty clearing station, and field ambulance was encouraged to equip itself with them. The regimental medical officer carried them with his field equipment. The field ambulances had them strapped to their sand carts. Every advanced dressing station was well equipped with them, and a report was called for on any case of this nature that came back from the advanced dressing station without one having been applied.

The most valuable illustration of the benefit to the patient of the Thomas splint for the treatment and transport of the fractured femur, that I observed, was during the fighting beyond the Jordan and hills of Moab. This took place at the beginning of 1918, and consisted of raids carried far into enemy country. During the fighting at Amman roads were virtually non-existent, and it was found almost impossible to bring up the guns, and still from here men with fractured femurs were successfully transported twenty-five miles on camel-back or in litters, and a further thirty miles in light Ford ambulances to the banks of the Jordan, where, at the corps main dressing station, they were dealt with by the advanced operating units.

The principles underlying the use of the Thomas splint are few, simple, and easily carried out, but, of course, the circumstances under which it is used were found to modify the method in which it was employed.

For us in the East a standard outfit was manufactured at the R.A.M.C. central splint factory in Alexandria. The aim underlying this outfit was to have one that was portable, and easily and rapidly applied. The rules that were laid down were that whatever method was employed, the extension must be maintained during transport. The ring of the Thomas splint must press against the ischial tuberosity and never slip over it. The lower end of the Thomas splint must be hung but not fixed to the lower stretcher bar. A suitable footpiece supports the foot.

The lesson the war taught us as regards the arrest of hæmorrhage, when met with in a case of compound fracture, or occurring independent of that injury, undoubtedly was the danger attending the use of the tourniquet. To allow a patient to whose limb a tourniquet had been applied to pass out of your sight or, worse still, from

* Abstracted from a lecture delivered before the Fife Branch at Kirkcaldy on December 5th, 1920.

under your care, came to be looked on as a professional disgrace. The advice we gave to the regimental medical officer dealing with a case of severe bleeding from a recent wound, and to the field ambulance officer doing duty in a crowded regimental aid post, was, in all cases where bleeding would not cease from a natural arrest, or could not be controlled by the local pressure of a shell dressing, to grasp the bleeding points with pressure forceps and send the patient down with these haemostats attached to his wound.

A story illustrating the application of this method is of interest:

As day was dawning on the morning after the first battle of Gaza there was brought to the 4th Casualty Clearing Station, then situated north of the village of Khan-Yunis, a convoy of wounded from a field ambulance. The most serious case in it was brought direct from the sand cart into the operating tent, and there came under my care. The patient was an officer of the Royal West Kent Regiment, who had been shot in the neck, the bullet having penetrated his chest and wounded the dome of his right lung. He arrived with two artery forceps projecting from the wound above the clavicle, and his field card informed us that the internal jugular vein had been wounded and the bleeding from it arrested by the application of pressure forceps. The wound was excised, the torn vessel ligatured, and the wound in the pleura and skin closed, and later on he was sent down the line. Some months afterwards I was asked to forward particulars concerning his case, and in reply received from a senior officer of the R.A.M.C., holding a responsible administrative post at the base, a letter thanking me for the services I had been able to render to his nephew, who had been my patient and had now rejoined his regiment. I was asked to transmit to the officer of the ambulance an appreciation of the deep debt of gratitude he had earned for having saved his nephew's life. This I did, and was amused to be shown by that field ambulance medical officer a copy of the correspondence he had recently received a-king him to account for the loss of two pairs of artery forceps, for the replacement of which he was held personally liable.

For the transport of cases of fracture of the femur, or injuries involving the region of the knee-joint, or in fact any case of fracture of any of the bones of the lower extremity, the Thomas splint sufficed. Up to the end of the war considerable difference of opinion existed as to the most suitable splint for fractures involving the bones of the upper extremity. From the many splints that were available and used for this purpose, I would recommend most strongly one which is easily and rapidly applied, and permits of the patient being transported in the greatest comfort—namely, the Hey Groves wire cradle arm splint. With this in your possession—and any blacksmith can make it for you in a few minutes—you require nothing more.

The transport and treatment of the case of shattered hip, pelvis, or spine is always difficult, and for such cases a Jones abduction frame is a priceless aid. It is awkward to carry, and the case for which it is suitable may be long in coming under your care, but if available when required it will be found of very great value, and contribute largely to the saving of life.

WAR LESSONS IN CIVIL PRACTICE.

The application of the experience gained by the regimental medical officer and his colleague to the problems met with in civil practice merits consideration. The regimental medical officer was the keystone of the successful medical service in the field. He knew it and was proud of it. Contrary to the regulations, he proudly wore the bonnet of his battalion, or the badge of his regiment, and wherever his men went there he was to be found. Prompt attention and prompt transport were his guiding principles, and in doing these well he did the greatest of the many services the wounded man received.

The general practitioner of medicine is the regimental medical officer of the industrial army, and the solution of many of the most fascinating problems is in his care, where recent injuries have to be dealt with. For example, what arrangements exist for the supply of Thomas splints to the coal pits in our neighbourhood? Where are they to be found at the pit bottom? Who is trained in applying them? Can the arrangements for the transport of the miner with the broken back from the coal face, where he has been hurt, to the pithead be improved?

If our civil advanced dressing station be an office at the pithead, or a neighbouring miner's cottage, the question of its equipment may be put to you. Drugs and dressings we will never forget, but what is of greater value is likely to be absent. If you receive the offer of help that I did when

stationed with my unit at Suvla Bay on the Gallipoli peninsula, I would advise you to reply, as I wired back, "Send sponges, rubber hot-water bottles (the army called them stomach warmers), and clean pyjamas." If you can deliver your case of fracture clean, warm, and with the fragments well splinted within four hours at corps main dressing station, you have done the best for your patient, even although the wound is uncleaned.

Most of the popular glamour of military surgery was focussed on the corps main dressing station, where the advance operating units worked, or on the casually clearing stations in France, where these formed the forward surgical centres. The patient having arrived in a suitable state for operation, the first problem was the disinfection of his wound. The evolution of this process underwent is of interest. Chemical disinfection was at first mainly relied on, and when the antiseptics in common use failed, new ones were invented. Watson Cheyne introduced an antiseptic paste with which the wound was filled, with results that proved unsatisfactory. Eusol was found of value, and the Dakin-Carel method of treatment was employed. Of the latter it may be said, as was once remarked of socialism, it would be an ideal practice in an ideal community, but in an ideal community it would not be required. Something less exacting in its demand on the time of the staff, something less fool-proof was wanted. Then came the saline tide. The introduction of chemicals from without having failed, we turned to a method whereby, with the aid of salt solutions, we flooded the wound with antibodies from within, normal saline solution, hypertoxic saline solution, and salt packs being used. Many were cured by this method, and several had serious secondary haemorrhage in consequence of it.

Finally the old adage was remembered, that the best of all antiseptics was the healthy tissues, and the excision of wounds was practised, all the unhealthy damaged tissue being cut away and the wound closed or united later by secondary suture. The many brilliant results that followed this line of practice must not, however, upset our temperate judgement. Many wounds will be found where complete excision of the damaged tissues is an anatomical impossibility. Others will be met with already seriously infected. For these cases two remedies were found of great value, one bipp and the other flavine.

Bipp and Flavine.

The use of bipp, or bismuth iodoform paraffin paste, was condemned as harmful by a number of surgeons with wide experience in the treatment of the wounded. In many cases, however, when the grounds for their criticism were reviewed, it was found that the method that had been employed in using the remedy was not that advocated by the originator of this line of treatment, Mr. Rutherford Morison, but that, contrary to his advice, a large quantity of it had been left in the wound, subsequently giving rise to harmful consequences. Some seem to have employed it as they would Beck's paste, filling up the entire cavity with it, and even thereafter closing the wound. Naturally the tissues resented such a foreign body containing irritant chemicals and endeavoured to expel it in the abundant discharge that resulted.

In the later stages of the war bipp was used in many cases in the Egyptian Expeditionary Force, and we found it to be of great use in many of them. Owing to the nature of the military operations that were being carried out, where the wounded had nearly always to be treated many miles from rail-head, and in all cases had to be transported through most difficult country before reaching the forward casualty station, or the hospitals on the lines of communication, it was frequently the case that the patient could not be re-dressed within twenty-four hours. When Damascus was captured the wounded were then nearly 400 miles from rail-head.

Where the wound was already infected, or where complete excision of it could not be practised, and the surgeon was compelled to leave behind a certain amount of devitalized tissue, the use of bipp was found of great value. It was possible in such a case to transport the patient in comfort and in safety, leaving the wound undressed for several days. Frequently his temperature was raised above normal, his pulse quickened, and a sero-purulent discharge escaped from the wound, which was swollen and somewhat oedematous, but it was noticeable how little pain he suffered. He slept well, his appetite was good, and later the wound was found to heal rapidly. The method employed was to cleanse the wound thoroughly of all

débris and damaged tissue, completely arrest all bleeding, and then disinfect it with spirit, after which a very small quantity of bipp was rubbed carefully into every corner of the wound, any slight excess that remained being carefully wiped off so that none remained visible at the end of the application. The wound was then packed, or in certain cases closed, and a spirit dressing applied.

The most astonishing results that were obtained by the use of bipp were in cases of gunshot wounds of the knee-joint resulting in acute suppurative arthritis.

Our experience with the use of flavine was interesting. At first from a study of the literature it appeared to us that at last we had here provided for us by Carl Browning the ideal antiseptic. It was non-toxic; it was virtually non-irritant. At first it might be employed in a strength of 1 in 1,000, and for subsequent treatment in a strength of 1 in 5,000. Instead of losing its potency when diluted in the serum of the tissues this was enhanced.

Our experience with the original consignment and with what we obtained later was similar to that of other observers—that it was a remedy with peculiar limitations. We found it an excellent remedy for pickling the wound. The wound remained remarkably dry, quiet, and irresponsive. The process of suppuration and the process of repair both seemed to be in abeyance, and it was found advisable to substitute, after it had been used for a few days, another remedy such as eusol or saline solution, when the wound then actively responded and healing took place rapidly. It will be thus observed that flavine found its greatest sphere of usefulness in cases where there was much damage of tissue which had to be transported long distances.

The lessons applicable to civil practice from these experiences appear to me to be the importance of early operative treatment in the case of a recent wound, such as a compound fracture, and the value of practising primary excision in these. If the tissues are extensively damaged and this cannot be practised, or if the wound is already infected, I would advocate that it be bipped, or, if the patient is to be transported out of your personal care, that it be packed with gauze soaked in flavine solution in the strength of 1 in 1,000.

GUNSHOT FRACTURES IN BASE HOSPITALS.

There are few who will deny the contention that one of the most brilliant achievements in the history of modern surgery is the record of the treatment of gunshot fractures as carried out in the base hospitals in the later stages of the war.

Many factors detrimental to success were present. Pearson and Drummond estimated that there were 5,000 new femur cases in the British army in France alone in the last nine months of the war, and this may be estimated to form only about 5 per cent. of all the casualties that had to be dealt with. Imagine the situation! Hospitals overcrowded at a period when they were being bombed during the night—so much so that some had to be moved and all patients evacuated and transported to England. For the 5,000 cases mentioned only a limited staff was available, and finally the class of injury that had to be treated was one where almost every one differed in some detail in its nature and required careful individual attention, and at any moment it was liable to provide you with that ghastly surgical tragedy—a severe secondary haemorrhage. And still the end results were uniformly brilliant.

Some will naturally seek for an explanation of this success in some new apparatus or new form of operative treatment that was employed. They will certainly discover that the young military surgeon invented and improved many articles of great use in dealing with such cases. These appliances all had this characteristic, that they further improved and simplified the immobilization of the fractured bone and at the same time further mobilized the patient.

The Balkan frame or Balkan bed that was extensively employed by them permitted the limb to be immobilized in any attitude desired, especially with the limb abducted. It also allowed of the patient raising himself in bed and even assuming the sitting posture, and, when the knee flexion piece was attached to the Thomas splint, flexion of the knee joint could be practised daily without interfering with the maintenance of continuous extension. To obtain this extension Pearson's callipers, which

grasped but did not penetrate the condyle of the femur, were especially beneficial and permitted of direct and accurate extension being carried out in a manner simpler and safer and over a longer period than did a Steinmann's pin. At the same time I must confess that my experience in the use of Steinmann's pins for transfixing the femur appears to have been unusually fortunate, for out of over a hundred cases in which I have seen it employed, I cannot remember one case that was followed by serious after-consequences due to its use.

In many cases Sinclair's glue proved of value, and for fractures in the region of the ankle his skate was of great assistance. The properly designed fracture bed with the bisent and half-bisent mattress helped most materially to increase the patient's comfort.

The possession of all these, however, was not the secret of the success obtained. This was mainly to be found in the whole-time staff of medical men, nurses, and orderlies that carried out the treatment. A continuity of policy could thus be practised, a standardization of the principles of treatment obtained, and the end-results observed by the keen and devoted team of workers who had cared for these cases. In other words, the cases were concentrated: the men anxious to treat them got them to look after. They had time to do so, and saw the final result.

The application of the knowledge to be gained from these experiences to civil practice is worthy of our careful consideration. To begin with, we start with this advantage, that most of our cases are much easier to treat, being simple fractures with unbroken skin. At a moderate cost a complete outfit can be obtained for treating a case of fractured femur. The simplest and best bed frame, in my experience, is the Morison R.I.E. bed-frame. Its invention is the outcome of the application of the wide knowledge of Sir Harold Stiles's late resident, Dr. Abbott, now of Ann Arbor in America, by Mr. Morison, engineer to the Royal Infirmary, Edinburgh.

The complete outfit should include a knee flexion piece for attachment to the Thomas splint and pressure pads for correcting local lateral displacement. A pair of Pearson's callipers and a pot of Sinclair's glue will complete our essential equipment, but a bent Thomas splint and a Sinclair's skate will be found most useful for treating fractures of the leg, whether simple or compound.

Even when all these were available, I have seen in a military hospital, and, more recently, in civil practice, a lamentable failure attend the treatment of a simple, straightforward case. Let us be frank and discuss the reason. Is it not to be found mainly in a disinclination or a lack of sufficient time to treat these cases on the part of the surgeon in attendance? Is it not true that in most hospitals the recently appointed house-surgeon, or even the surgeon in charge, estimates the luck of the waiting day, on the following morning, by the number of cases of fracture that have not been admitted? He much prefers that vacant beds should be available for the admission of cases requiring operative treatment where the problem to be dealt with is rapidly solved in the operating theatre, and little further is required but hasty observation of his patient's progress.

In so many hospitals the visiting staff have not time to devote to the proper care and treatment of fractures, and in nearly all hospitals the tenure of office of the house-surgeon is so brief that his period of service has almost expired before he really understands how to deal with such cases, and he relinquishes his appointment in favour of one who in his turn has to be trained.

I do not suggest that great skill or dexterity or prolonged study is necessary to treat cases of fracture. All that is required is a devotion to this branch of surgery by one who has the time and enthusiasm to carry out carefully daily observations on the progress of his patients and note the faults at their inception, when they are usually easily corrected. The fundamental principles underlying this practice are few, simple, and easily understood.

In military surgery, when the patient was discharged from the general hospital he was transferred to a convalescent dépôt. On the whole he had a very good time there. He had ample opportunity for rest and relaxation, and its environment was usually such as to encourage him to be out and about, and games suitable for his crippled state were usually provided. From this hospital he was transferred to the command dépôt, and on the day of his admission graded in his suitable class. If seriously crippled

he would be put in the fourth class and looked after by a medical officer. The officer in charge of the dépôt was a combatant, but no patient could be transferred from his class to a higher one without the approval of the medical staff. Ultimately, as he gradually improved, he would reach the first class, where he was capable of carrying out regular exercises, usually in the form of specially designed games, and also certain duties, such as mounting guard and light fatigues. Before he returned again to his regiment he was boarded, and the final result of his treatment was not judged by what he who originally operated on him thought, but by the cold light of the end-result obtained. The question then was, Can he wear his equipment? Can he march five miles with his pack? Can he do the full and arduous duties of a soldier of the line? And if so he was considered a Class A man.

The lessons we learn from this are of course extremely difficult to apply to civil practice in our democratic community, but I am sure that there is here a great field for improvement in our surgical work. Rigid and compulsory training or exercises are sought for by no civil surgeon that I know of, but the harmful effects of their absence are seen in almost every compensation case following injury. A very great deal, I am sure, can be obtained voluntarily, and if the facilities existed and their benefits were demonstrated in the case of a few the great majority would soon seek to participate in them.

ECONOMIC ASPECT OF FRACTURES.

The economic importance of the treatment of fractures is realized by us all. The injury is usually met with when the patient is at the height of his wage-earning capacity and has the responsibility of a household and family dependent on him.

The issue of the BRITISH MEDICAL JOURNAL of November 30th, 1912, contains the report of the British Medical Association Committee on the treatment of simple fractures:

In Table VII, which deals with all fractures occurring in patients over 15 years of age, those treated by non-operative measures were 1,324; their average duration of incapacity was 27.6 weeks. The number of cases in which the incapacity was permanent was 121, or 9.02 per cent. There were 179 cases of fracture of the shaft of the femur, the average incapacitation being 33.6 weeks, and the number of cases in which incapacity was permanent was 21, or 11.7 per cent.; 673 were fractures of the shaft of the tibia and fibula, the average number of weeks of incapacity being 26.7; 41 of these were permanently incapacitated, that is, 8.1 per cent.

Recently I discussed with a large employer of labour the question of hospital organization and the economic importance of the treatment of fractures in the industrial world, and he was kind enough to give me access to information bearing on the financial side of this question.

I have been provided with a consecutive series of 22 cases of workmen who in the year 1917-18 suffered fractures of the bones of their lower extremities in the course of their work. Of these, 7 were fractures of the thigh, 14 fractures of the leg, and 1 was a fracture of the thigh and leg. To these £2,932 11s. 5d. was paid in compensation, and out of the 22 fractures, 14 exceeded a period in which their recovery might be fairly anticipated. It is estimated that the extra compensation paid by the employer in consequence was £1,553. It is also estimated that the financial loss to these 14 men amounted, even after crediting them with their compensation, to £3,663, the total loss being thus £5,221, a sum which appears even more impressive when capitalized as an annual charge at 6 per cent., when it amounts to £87,000.

I do not say these figures are accurate and beyond dispute. No statistics are. The important feature of them, however, is that they are considered so by the person who has provided me with them. According to the information possessed, he and his fellow masters of a great industry believe, apart from humanitarian grounds, that there is value to be obtained by themselves, their employees, and the State from good surgery. Their deliberate conclusion is that, when calculated on the 1918 basis—which, of course, is much lower than now holds good—a sum up to £5,221 may economically be expended in one year in improving the treatment of 14 cases of fracture.

We all realize that there is very considerable scope for improvement in our treatment of fractures. Most of us will acknowledge that if we are given paper and a pencil and the pocket of the British taxpayer, that so many in the present day seem to imagine is bottomless, to finance

our schemes, we could produce in half an hour an excellent plan on paper wherein there was created something similar to a field ambulance at every coal-face and a casualty clearing station at every pithead. But, fortunately, we will not be called upon to do this, and something more economical and more efficient, at least as the Briton works, will have to be produced.

THE PART OF THE GENERAL PRACTITIONER.

I think it is of vital importance, when any scheme of medical reform is being discussed and thought out, that the cardinal underlying fact should always be borne in mind that it must be based on the general practitioner of medicine, who has the care of the health of the industrial army. All such schemes should be so thought out that, when completed, they come to the general practitioner, not to take from him the cases he is at present treating successfully and economically, but preferably he should be approached and asked what he requires to do that work more efficiently, more rapidly, and more successfully. The care of the recent accident and the arrangement for its transport must always be his sphere of duty. The equipment necessary to carry that out can, however, be centralized for him and distributed as he advises.

The serious case of fracture will always require prolonged institutional treatment, and the question is who is best able to carry that out. In the issue of the BRITISH MEDICAL JOURNAL of November 20th, 1920, you will read a most interesting article by Sir Robert Jones on orthopaedic surgery in relation to hospital training. He advocates that all fractures, whether recent or old-standing, ununited or malunited, shall be given over to the care of a special orthopaedic surgeon, who shall have a fully equipped department to deal with them.

In certain teaching hospitals I think this is a sound proposal, for these departments would set a standard for all and provide the necessary post-graduate training school for a wide area. For the provincial smaller hospital, however, this scheme appears to me not to be possible; but I consider that it would be an experiment well worthy of being tried to hand over all cases of fractures admitted to such an institution to the care of a member of the staff especially appointed for the purpose. The ideal man for such a post would be a local general practitioner, not too busy, and with an instinctive love for hospital practice. If I had to select him I would choose one whose inclinations were not for work in the operating theatre. I would almost go the length of prohibiting him from doing general surgical operative work. He will find the care of these cases a fascinating study. They will require a daily visit and frequently a call again in the evening. To assist him he will require a whole-time nurse trained in the simple elements of massage. It is absurd and unsatisfactory to expect him to do this work gratuitously or on a charitable basis, and he, of course, would receive payment for his services. The source of this revenue I cannot do more than suggest, but it seems to me that, in the light of the figures I have already given, if the case for efficiency in the treatment of such cases is laid before the master and men concerned, they would not hesitate to meet such an expenditure. The financial saving, if nothing more, it would effect would be immense. Certainly it would well justify at least a five years' trial.

The problem of the fracture case that is discharged from hospital and continues to drag on, showing little improvement, is one of great difficulty, but a suggestion as regards its solution is contained in the BRITISH MEDICAL JOURNAL of September 18th, 1920, in an article by Dr. T. Lister Llewellyn on a physical therapeutic centre, and I am sure it should not be difficult to discover. Such a scheme is voluntary in its features and British in most of its characteristics, and consequently offers, in my opinion, the greatest prospects of success.

ON February 8th the 346th anniversary of Leyden University was celebrated by an address delivered by the rector magnificus, Professor R. van Calcar, on the development and significance of modern bacteriology.

At a recent meeting of the Vienna Urological Society, the president, Dr. Zuckerkandl, delivered a eulogium on the late Professor Guyon of Paris, all the members standing up in token of respect.

An Address ON INTERNATIONAL ORGANIZATION AND PUBLIC HEALTH.*

BY
G. S. BUCHANAN, C.B., M.D.

SENIOR MEDICAL OFFICER, MINISTRY OF HEALTH; BRITISH
DELEGATE, LEAGUE OF NATIONS HEALTH CONFERENCE.

THE invitation of your President gives me the opportunity of drawing the attention of the Society to some recent international arrangements for the promotion of public health, and in particular I have thought it would be of interest to say a few words about the International Health Organization which will shortly come into being, as a result of a series of detailed resolutions which were passed by the Assembly of the League of Nations at Geneva in December. With the project envisaged by these resolutions I have personally been somewhat closely associated, as it was my privilege to be nominated by the Ministry of Health, on the recommendation of the chief medical officer, to be the technical adviser on this subject to the British delegation, and, what in this connexion was perhaps more important, to take part in the original international discussions which were initiated by Dr. Addison more than a year ago, when it became necessary to examine the position in regard to international health matters which had been created by the treaty of Versailles. It will be remembered that by the Covenant of the League of Nations, which forms an integral part of that treaty, the members of the League undertook to take steps in matters of international concern for the prevention and control of disease. The League is also empowered to take over the direction of international bureaux established by general treaties, among which is included the existing Office International d'Hygiène Publique, which was established by the Convention of Rome, 1907.

These provisions undoubtedly form something of a landmark in public health history, by giving formal expression to the importance which health questions now assume in the practical affairs of the government of the nations of the world. They show, internationally, the effect of the same movements which in this country led to the central amalgamation of health services and the creation of a Minister of Health; which in France also have since led to the splitting off of public health administration from the other departmental matters which were overshadowing it at the Ministry of the Interior; which have resulted in the Ministries of Health which have been established in the new countries of Central Europe; and which have brought about also the remodelling and strengthening of central public health services which we are now witnessing in the United States and in our own Dominions. The Covenant wisely recognized that as nations thus increase and strengthen their internal health government, new points of contact, need for common action, and even risks of political differences must arise internationally. It was necessary that a league, designed to secure comity among nations and to prevent or resolve disputes, should bring public health questions within its range of activities.

The practical sanitarian, accustomed to look with small enthusiasm on the elaboration of schemes which appear far-reaching only on paper, and with that mistrust of long views which is so useful in the pursuit of our calling, is perhaps likely to exhibit only a mild interest in the fact that the League of Nations, whose own future in many directions is uncertain, has taken to itself a wide outlook over technical matters—economics, finance, international transit, world conditions of labour, and the like—and has added public health to them. It is for him of greater interest to take the short view, and to ask first whether, as a practical matter, international official action can contribute anything worth having at the present time to public health that cannot be obtained as easily without it, and then to inquire how, through the League of Nations or otherwise, it is proposed that this action should be taken. The manner of doing things, as he knows well, is often at least as important as the matter of them.

To answer this question, it may be useful to begin, and perhaps rather in a wholesale way, by a process of elimination. It must be remembered that the League of Nations represents associated Governments, and its activities depend, first and last, on the views and action of Governments—in other words, it is an official machinery if it is anything. For international co-operation in health questions that do not require official or Government intervention and support a League of Nations machinery would offer little advantage. Accepting this, we can at once exclude from the question before us much that can in a general sense be termed international medical work. All medical science, in a sense, is international; it is as cosmopolitan as music. In medicine, least of all, do we want to ask, when we hear news of progress, whether or not it is "official." Jenner, Pasteur, Metchnikoff, Ehrlich—it is the man's work that leaps to the mind with names such as these, not their nationality. We do not need to set up an international bureau to tell us in all the official languages of discoveries and new knowledge given us by workers all over the world. Have we not enough—even more than enough—of abstracts and summaries and translations? There are special cases, to which I will refer shortly, where we can only get the information we require for public health work through Governments, but all will agree that our own journals, not forgetting the *Medical Science Abstracts and Reviews* of the Medical Research Council, which give them freely and in one tongue, amply suffice for all ordinary needs, while we have also all our medical societies—always on the look-out for information from other countries—and our international medical and sanitary congresses, which are all the better for their voluntary character and independence.

So also with research. At the assembly at Geneva much attention was given to an attractive proposal by the Argentine delegates that the League of Nations should promote medical research on a large scale by establishing and financing a large central research institution, and should take active part in the establishment of health laboratories all over the world for the investigation and prevention of disease. The project, had it been pressed and accepted in committee, would probably have been wrecked on the financial rocks; the budget and commitments of the League and its proposed technical organizations were being closely scrutinized. But it was at least debatable whether on its merits it would have been right to press it. Someone once proposed to give a great mansion and grounds for habitation by poets, where their products could be turned out under ideal conditions of comfort and in contact with other poetic minds. The true medical research worker would probably be as horrified at the prospect as the poet. Without shutting the door to future functions of an official international health office as a clearing house for certain kinds of research work—a matter obviously to be considered—it cannot be maintained that nations wishing to progress in medical science would be doing their best by putting their men and money into any international forcing house for research. Both would be better employed at home. Moreover, the days of private support to public medicine are happily not over. The Rockefeller Foundation, with its world-wide humanitarian scope, gives us an example of a magnificent form of internationalism all the more effective by its freedom from official control.

So again with the great humanitarian institutions. The benevolent in all civilized countries combined in the interests of international public health. The various Red Cross organizations, now so much strengthened in authority and funds by the war, have united to form a common organization—the League of Red Cross Societies—which is to work for health in time of peace, with the special function of educating and helping backward or poverty-stricken countries. These Red Cross activities received special recognition in the Covenant of the League of Nations, which requires the signatory countries to encourage them. I do not propose here to formulate the lines of demarcation which should be followed between this important voluntary body and an official health organization of the League of Nations, especially as the matter has been recently and fully discussed by Sir George Newman in his first annual report to the Ministry of Health. The various conferences on the subject have always led to the same conclusion—namely, that in practice the line should be easily drawn (the more so as the League of Red Cross Societies is itself

* Read to the Society of Medical Officers of Health on February 18th, 1921.

established in Geneva); that not only should there be no reason for rivalry, but each should be strengthened by the other. It is the fact, I believe, that the League of Red Cross Societies has already found itself hampered by the absence of a health section at the League of Nations, and it is obvious that the latter, when established, will be much advantaged by what has already been accomplished and prepared by the Red Cross organization. The situation, in fact, is one which is familiar to public health officers in every administrative area where voluntary work and expenditure of voluntary funds on health matters go on side by side with official work; when ordinary tact and prudence is exercised harmony and mutual benefit is secured.

WORK FOR THE INTERNATIONAL ORGANIZATION.

If any further fears are entertained that those who have been concerned with this question have been carried away by unreasoning international idealism, or have bureaucratic designs to capture public medicine at large by some new international machinery, they will, I think, be sufficiently dispelled by a study of the objects which the proposed organization is in fact required to fulfil. These objects are stated as follows in the resolutions of the Assembly; it will be seen that their terms are carefully guarded.

OBJECTS OF THE INTERNATIONAL HEALTH ORGANIZATION.

(a) To advise the League of Nations in matters affecting health.

(b) To bring administrative health authorities in different countries into closer relationship with each other.

(c) To organize means of more rapid interchange of information on matters where immediate precautions against disease may be required (for example, epidemics), and to simplify methods for acting rapidly on such information where it affects more than one country.

(d) To furnish a ready organization for securing or revising necessary international agreements for administrative action in matters of health, and more particularly for examining those subjects which it is proposed to bring before the Standing and General Committees, with a view to International Conventions.

(e) In regard to measures for the protection of the worker against sickness, disease, and injury arising out of his employment which fall within the province of the International Labour Organization, the International Health Organization will co-operate with and assist the International Labour Organization, it being understood that the International Labour Organization will on its side act in consultation with the International Health Organization in regard to all health matters.

(f) To confer and co-operate with international Red Cross societies and other similar societies under Article 25 of the Covenant.

(g) To advise, when requested, other voluntary organizations in health matters of international concern.

(h) To organize missions in connexion with matters of health at the request of the League of Nations, and with the concurrence of the countries affected, within the limits provided by subparagraph (a), or by the International Convention of Rome (1907).

The way is now clearer to continue with the practical question which I have assumed to be put. The objects of the organization have been settled and defined in the general terms which I have just given. Representatives of the public health departments of the civilized countries of the world will be collected together to pursue them. What is ready to their hand to begin upon?

The material is really abundant and important, none the less important, perhaps, because the subjects concerned are somewhat technical, and unlikely to make much appeal to popular imagination. We have first a number of health questions connected with frontiers, both sea and land. The measures taken in regard to ships coming from infected ports have in this country a long history, beginning with the now obsolete Quarantine Acts, going on to the International Sanitary Convention of 1903, with which our present practice conforms, and ending with the most recent International Sanitary Convention, that of 1912, the ratification of which was completed only a few months ago. One of the most creditable contributions of this country to the public health of the world resulted from the appreciation which was given in England at a very early stage to the fundamental principles which should govern the action taken by port authorities to prevent the introduction of diseases like cholera and plague, so as to combine a maximum of efficiency with a minimum of interference with traffic and commerce. The international

adoption of these principles, though secured by international agreements, has, however, not seldom stopped at the signature of these agreements. Some countries have regarded sanitary conventions as merely giving minimum requirements, and in practice have superseded them by laws and regulations greatly in excess of the principles of the agreements to which they are signatory. Other countries, including certain of the British colonies, have stayed out of the conventions and retained old-fashioned quarantine laws. All these conventions depend in large measure on a system of formal notification to other countries of the first occurrence of plague or cholera in an affected country, but their requirement has often been defeated by the burden of its own formality. Under the conventions the health department of one country does not notify the health department of another, but the information proceeds through diplomatic channels and foreign offices, for which, naturally enough, any report of plague or cholera carries with it visions of disaster, restrictions, reprisals, and other fantasies which attend the unknown, and thus leads, if not to suppression of facts, at least to delay and to studied ambiguity in their presentation which defeats the object of the notification. And perhaps the greatest difficulty with these conventions—the observance of which is of such great importance to commerce as well as to health—is their want of elasticity. The Convention of 1912, drawn up after long conferences and discussions, was ratified only last year. Though in many ways a satisfactory code, and in advance of that of 1903, it is already in several respects out of date—in regard to plague precautions on ships it still treats human plague infection, and not rat plague infection, as the primary consideration; in regard to cholera, it gives no sufficient guide about the carrier; in regard to yellow fever, its requirements do not satisfy, and are not practised by, any of the countries in the yellow fever zone, and they are considered insufficient by India, which is now apprehensive of the introduction of this disease.

Meanwhile, there is an insistent demand, not only from our own administration, but from that of many other nations, for the establishment of international rules which should govern the handling of other infections, such as small-pox and typhus, not dealt with in the present conventions. These are of daily importance, particularly in connexion with the migrations which are beginning, and likely to be continued, from the epidemic-stricken regions of Eastern Europe. The demand for revision here extends to the case of land frontiers, which hitherto have received scant consideration in international conventions. The division of large parts of Europe into new States, the probability that for many years to come small-pox, typhus, cholera, and other acute epidemics may progress westward through the Continent, and particularly the unhappy experience already gained on the borders of Poland and Soviet Russia, make it essential on land frontiers that, on the one hand, strict measures should be taken for observation, detention, disinfection and the like, applicable to persons of all nationalities; and, on the other hand, that these measures, like those for shipping, should be so contrived as to produce the minimum of interference and annoyance in international traffic and commerce.

Now, in present circumstances it is difficult for any busy public health officer to contemplate without dismay the prospect afforded by a new and protracted official international conference to recast and reconsider all these questions.

Many new States will for the first time come into these deliberations; they cover a larger ground than before; and when a solution is ultimately arrived at, there is a prospect that it can only be made effective by a repetition of the diplomatic procedure which delayed us for eight years after 1912, that the resulting document might once again be out of date by the time it is ratified, and that it would, after all, leave us as uncertain as before of the extent to which the Convention, when completed, was observed in practice by the signatory countries.

An official central health bureau, with international authority and adequate machinery, affords the most hopeful way out. It has already been proposed that the next International Sanitary Convention should be framed on broader and simpler lines, leaving details to be filled in by schedules and supplementary agreements. This is feasible if a standing expert authority has the duty of making adjustments as occasion requires to meet advances

in knowledge and changes in the epidemic situation. In an International Health Organization on which all the central health departments of the chief maritime States are represented there should be no difficulty in designating the right men for this purpose, and in securing international approval of necessary amendments without long delays and needless formalities. Such an organization, moreover, could do much to secure that accurate information is obtained regarding the measures taken in each country to give effect to the agreements.

The Geneva resolutions, besides providing for this central body, lay down a new method for the conclusion of conventions on health matters which, it may be hoped, will remove some of the obstacles met with hitherto. The efficacy of this method has still to be tested, but in any case the main cause of past delays—the fact that it has been nobody's business to see to progress—should now be removed.

Another matter requiring attention at the present time is the collection of intelligence regarding the progress and prevalence of principal epidemic diseases. At the Ministry of Health we find this essential not only for our own sanitary administration, but also to meet, as we desire to do, the strongly expressed wishes of our self-governing Dominions for such systematic intelligence. Port medical officers of health who receive from the Ministry the weekly statements of epidemic diseases abroad, which have lately been much expanded and improved through the energy of my colleague Colonel S. P. James, will realize the duplications of labour which result from the present system—indeed, its absurdity, when it is remembered that other countries, like the United States, are laboriously and independently following the same method. At present we obtain a large amount of our information about epidemics by the co-operation of our Foreign Office and through the zeal of British consuls abroad. In existing conditions this is the only way, and is most helpful. But, after all, the consul, himself a layman, has to approach a foreign lay municipality for his facts, and at best can obtain them only for a limited area of the country. Other consuls at the same place are going through the same system of inquiry and cabling to their Governments. For some countries, China, for instance, no efficient substitute for consular information can be suggested. But for many nations it ought to be practicable to replace messages from British representatives in a few centres by a single communication sent to the Ministry of Health by the corresponding department of the foreign country. We are already in England able to give such information either to other countries or to a central office. The practicability of the establishment of a central epidemic intelligence centre in connexion with the new International Health Organization needs to be studied in detail and as soon as possible. It would hasten more than any other measure the codification of epidemic intelligence in countries like France which have not yet developed notification as we know it over here. Given the necessary communications from the periphery, a central transmitting station such as the League of Nations is bound to possess, and the condensing resources of a code, it should not be difficult in a few words to signify each week to all the countries the main facts of each of the principal epidemics which require to be watched. Much less useful matter is daily transmitted all over the world by wireless. The expense should not be great, and would be saved in other directions by every country concerned.

The hygiene of ships, so far as it affects that deserving but often hygienically neglected section of the population termed merchant seamen, is receiving attention on the international side from the International Labour Office, and is being brought into great prominence by seamen's labour organizations all over the world. Its settlement requires international action in which the best and most recent public health knowledge should be incorporated. The Geneva resolutions establishing the International Health Organization have now provided a means by which competent sanitarians can take their proper part in the international regulation of matters like ship ventilation, the construction of crews' quarters, their rations, facilities for cleansing, and the like. The subject bristles with difficulties, but also with great opportunities, and I may express the hope that when proposals on this matter are taking concrete form, the British delegates may have the

advantage of assistance from those medical officers of health of port sanitary authorities who have specially studied the hygiene of ships' crews.

Let me refer also to another international measure affecting merchant seamen—their treatment for venereal disease at seaports. This ground has been explored officially by the Ministry of Health, and unofficially by the National Council for Combating Venereal Diseases, and we are convinced that international agreement is both desirable and practicable to ensure that at any large seaport the sailor has access to modern methods of treatment, without charge or disability to himself, without reference to his nationality, and, if I may express a personal view, without cost or prejudice to the shipowner. This treatment should include in-patient treatment where necessary, and a standard form of record of his condition and treatment—forms of record really may have their uses—which he can take with him to the next port.

Nothing approaching this system at present exists, but little consideration is necessary to realize the gain which might accrue from such an international undertaking. The practical difficulty hitherto has been that no one nation has been in position to press the matter strongly on other nations and remove the minor obstacles, still less to secure that the goodwill and assent of other countries, when obtained, is translated into appropriate action.

I may refer to two or three other health questions which seem ripe for international agreement, or study with a view to agreement, and should where necessary be taken up in consultation with the International Labour Office in the interest of the workers. One is anthrax, where at least two things are required: First, the general adoption of a system officially recognizing that raw hides and wool have been disinfected by an approved process at the place of their collection or the port of dispatch. This system, which would produce a great saving and greater efficiency, has been shown to be practicable by the work of Dr. Legge, Dr. Eurich, and others in this country, and the minute attention given to the whole question by the Anthrax Committee and the Home Office. Secondly, there is real need for an understanding about the future of the important Japanese export trade in shaving brushes. The British Government has been obliged, by the demonstrated danger of these brushes, to prohibit their importation altogether. It is undesirable that we should have been forced to this procedure, especially as other countries have not taken corresponding action. The real remedy seems to lie in action in Japan to secure that the hair, usually imported from China, is efficiently cleansed and disinfected before it is made up, under the supervision of Japanese bacteriologists, in whom all the world can have confidence, officially arranged and guaranteed by the Japanese Government.

Then again, to revert to a subject which affects port sanitary authorities and shipping, there is the subject of periodic destruction of rats on ships. There is no reason why a ship should not be overhauled to remove its rats every six months as a routine just as necessary as its repainting, or the overhaul of its boilers. Such a requirement, which would be greatly in the interests of shipowners, as well as of health, could only be effected by international agreement, coupled with a system of intelligence at the central offices regarding the action to give effect to the requirements of that agreement.

There can be no doubt that the work of medical statisticians is greatly hampered by unnecessary differences which at present exist in methods of certifying and of recording deaths. I may draw attention in this connexion to a useful article on death certification contributed by Professor Glaister to the last number of the *Journal of Comparative Legislation*. When one remembers that the vital statistics of Switzerland, for example, are obtained by a system of confidential certification in which the medical cause of death is not stated to friends and relatives, one realizes how large a discrepancy there may be in the comparison of the vital statistics of that country with others in respect, let us say, of alcoholism or syphilis. Then, again, the use by the certifying doctor of "primary" and "secondary" causes of death is a matter in which there are divergencies so wide as to make vital statistics which are seemingly comparable really incompatible in actual fact. Even as between England and Scotland there are a few differences of this kind: a death which is certified as due primarily to

influenza and secondarily to pneumonia will in England be ascribed to influenza, and in Scotland to pneumonia. There must, of course, be substantial differences between countries in regard to the reliability of their death certificates and vital statistics, even between those which are most highly civilized; but, at the same time, a great many points of difference have only to be pointed out and discussed in order to be removed, with great advantage to comparative work. Some effective progress has already been made in this matter on the question of tabulation of causes of death under the headings of the International List, which is revised every ten years. The conference last year at Paris, which completed the most recent decennial revision, was at once an example of the praiseworthy desire of statisticians and registrars to obtain international accord in their "long" and "short" lists of causes of death, and a demonstration of the ineffectiveness of the arrangements which at present exist to bring about that accord in a satisfactory and convenient manner. Anyone who experienced, as I did, the difficulties of discussion of a large number of complicated details by fifty delegates of different nations meeting on four consecutive days from early morning to late night, and trying to make progress without agreed rules of procedure, agenda, drafts, copyists, shorthand writers or interpreters, would not need to be convinced of the practical advantage of transferring such work to a centre where all these arrangements for international discussion are automatically and well supplied.

Another important aspect of international official work lies in the direction of combining efforts to deal with exceptional epidemic conditions. This has already been illustrated in connexion with the advance of typhus and cholera from Russia into Eastern Europe. To check that advance, especially by dealing at the frontiers with the large numbers of refugees, prisoners of war, and the like arriving from the East in mass along the principal railway lines, *en route* to all parts of Europe, is a matter which obviously concerns many Governments very vitally, apart altogether from the humanitarian aspect of the question, which may be considered to affect the whole world. A large amount of voluntary aid has been forthcoming or promised to deal with this situation, especially through the Red Cross agencies, but the conditions in Poland and the other border States has been such that it has been impossible for this voluntary action to be made effective without strong official international backing. Moreover, the resources of the charitable public in the United States and elsewhere have been insufficient to secure the necessary preventive measures on a sufficient and systematic scale. In these circumstances, the League of Nations, as is well known, has made an effort to supply the need by appointing a special epidemic commission and obtaining funds for this work from a large number of the Governments represented in the League. Although these funds are not yet adequate for the purpose, they have even now been sufficient to enable a good start to be made in the most difficult and dangerous area, and the Typhus Commission, with general consent, is now able to attach to itself, or direct the use of, the important auxiliary services which the Red Cross bodies are able to bring in.

Occurrences of this kind are not likely to be numerous, as in all ordinary cases an epidemic-stricken country would take its own measures and be unwilling to call for, or to receive, international official help. When they do occur, however, as to-day in Eastern Europe, or as they may arise to-morrow, say, in the case of pneumonic plague in the East, it is evident that the League of Nations can only act effectively and quickly if it has behind it experts who can appreciate the situation and the needs of the case, and are in close touch with their Governments. The absence of a public health organization in the present case has been one of the serious handicaps to the League in the prosecution of its campaign against typhus.

It may be added that if the Treaty of Sèvres is ratified, still more if it is taken as a precedent for other treaties, the League of Nations will assume a very direct responsibility in regard to quarantine. Under that treaty the League will be required to form a special committee to co-ordinate the practice of the different quarantine stations which deal with the Mecca pilgrimage.

METHODS OF ADMINISTRATION.

Leaving these questions of the work before the organization, we may now consider the further practical question how such work is to be effected. It requires that a body of men should be got together at least once or twice a year from a large number of countries who are persons of some weight and authority in the public health work of their respective Governments, and who, if they are not themselves expert in the particular technical question of the moment, will have been able to obtain or to bring the best technical assistance or advice on the subject. If we were on entirely new ground with no experience, it might be difficult to say that this is likely to be practicable. Fortunately, however, we have the necessary experience. Such meetings to a large extent already take place once if not twice a year at the Committee of the Office International d'Hygiène Publique in Paris, which is to form an integral part of the new organization. This Committee is in one important respect wider than any body could be which only represents members of the League of Nations at the present time, as it includes the representative of the United States Public Health Service. The Office International d'Hygiène Publique was established by the Convention of Rome of 1907 with a constitution which enables it, as a consultative body, to deal with most, if not all, of the subjects which I have mentioned above. The value of the past work of the Office International must not be belittled or overlooked. It is hardly as well known in this country as it should be. The Office has been a very bad advertiser, and, as its meeting place and offices are in Paris and its official language is French, it has been regarded here as perhaps too exclusively a Latin institution. The *procès verbaux* of its meetings are formidable official records which are seldom found outside Government offices, and its *Monthly Bulletin*—which is on sale and, incidentally, at the rate of exchange of to-day, represents a higher public health value than any other periodical known to me that is purchasable for 5d.—is largely concerned with official regulations, and its abstracts and epidemic intelligence, though very well done, are apt to be a little out of date.

As regards its conferences, I can only speak personally regarding those held since the Armistice under the able presidency of M. Velghe, the Principal Officer of the Belgian Public Health Service. There can be no question of the great practical value of these meetings, which has been proved especially in connexion with the information interchanged and collected regarding the influenza pandemic, the present prevalence of encephalitis lethargica, the practical measures adopted to deal with venereal disease in other countries, and other matters. At the recent sessions, moreover, since the question was raised of providing for international health work on a larger scale and with more important machinery and larger funds, the delegates to the Office International have most materially advanced the consideration of a number of the international questions to which I have already alluded, in particular the revision of the Sanitary Conventions and the proposed agreement to deal with venereal disease at seaports. In general it may be said that the delegates are precisely the men who would be selected by their Governments to represent them on any important international health question involving official action. The British Empire representation has recently been a strong one, as we have been fortunate in including representatives who are either leading public health officers in their respective British countries or have recently held such appointments.

All those who have had to consider the way in which the health obligations in the League of Nations Covenant should be met, and the nature of the problems before us, have agreed that continuity should be secured and that the League would benefit by the experience and personnel of the Office International. Moreover, the Covenant has made it impossible for the Office International to develop in any useful direction by continuing an independent existence. This view by general consent and goodwill has now been adopted in the resolutions of the Assembly. The International Health Organization is to be based on the Office International, which will in future have additional representatives from certain countries like Japan, which are members of the League but have not previously sent delegates to the Office. The League of Nations

system of General Assembly, Council, and Secretariat, has, broadly speaking, been followed in the subsequent arrangements. The Committee of the Office International, enlarged as indicated, becomes the equivalent of the General Assembly of all the nations. Under the name of the General Committee of the International Health Organization it will continue to meet in Paris once or twice a year and retain its offices there. Its work will be carried on under its former constitution, with such modifications as may be necessary to fulfil its further duties of advising the League. It will, however, be provided with a standing committee, roughly analogous to the Council of the League, which can meet in the intervals of the general meetings, appoint subcommittees, and arrange for expert inquiries, and it is to have a medical secretary and office at Geneva. The Assembly has allotted some £17,000 to the organization for its first year, and it will continue to receive also the relatively small contributions from the signatory Governments which have hitherto supported the Office International.

It may be noted with satisfaction that the official requirements for the working of the organization laid down by the resolutions of the Assembly are, as international arrangements go, relatively simple. Much latitude has been given to the organization to work out its own procedure as circumstances dictate.

It is true that the system could have been very considerably simplified if we could have envisaged the appointment at Geneva of a superman for international health, possessing a large central office and staff, in position to prosecute inquiries in and demand information from the respective national health offices of the world, and to lay down international rules with which those national offices would comply. But no public health department in any country would be prepared to accept this dictation at the hands of any man, however distinguished. And if they were so prepared, no Government would be disposed to accept such a system. There were, indeed, many indications at Geneva of the intrinsic objection held by the representatives of the constituent nations of the League to any international procedure which suggested servitude to a central bureaucracy.

Common action among nations, for purposes such as we are considering, must depend upon the fullest discussion and consideration of the position of each country—even in such technical matters as quarantine laws or death certification or standards of ships' hygiene—and on willing agreement after such discussion. This means a slow rate of progress, of course, but it is necessary, and the originators of the health scheme have recognized it by making the meetings of representatives of all countries—that is, the General Committee which continues the Office International d'Hygiène Publique—the real basis of the organization; the new additions of standing committees and secretariat being the necessary auxiliaries to its efficient work. Any permanent headquarter officers who are appointed will need ability and experience in handling the subjects for inquiry and giving effect to the decision of the international representative body. But these, after all, are qualities exercised every day by medical officers in every important public health service, no more difficult or complicated than managing the health matters of a great municipality. They require good men, but not Napoleons.

CONCLUSION.

It is permissible, I think, to conclude from this short survey that the International Health Organization of the League of Nations will have before it on its formation a number of important practical matters of hygiene which are ripe for concerted Government action, and already call for an organization representing the official public health services of the civilized Governments of the world; that it will start on these subjects with the advantage of continuing the collaboration which has been obtained in the more limited sphere of the Office International d'Hygiène Publique under the Rome Convention of 1907, and of the preliminary work already done by that Office in several of the subjects awaiting settlement; and finally, that the means and funds placed at the disposal of the organization for meetings, inquiries, and draft agreements, promise to be satisfactory for the purpose.

I think this is quite enough to enable us to wish it a good start and every success on an admittedly difficult road, without prophesying for it a future extension in

many other directions which can be suggested, or must even be anticipated if the League of Nations increases its authority and influence, or if, whether through the League of Nations or in any other way, the countries of the world demand in future a much closer degree of international co-operation for objects such as public health. In any event, the outlook for the organization will largely depend on the willingness of the public health services in the different countries to make use of the present opportunity, and the support which these services in so doing receive from their Governments. One satisfactory part of the scheme adopted by the Assembly should be noted. The League of Nations will have its budget control, a certain power of withholding sanction to action proposed by the organization, the right of sanctioning appointments of paid officers, and of receiving reports, but, apart from these, the general working of the organization, the regulation of its internal affairs, and the appointment of staff is left entirely to the organization itself—in other words, to the public health men themselves.

Here is the opportunity of the public health officers, and it is to be hoped that they will not only be willing to seize it—this may be taken for granted—but will find themselves in position to give necessary time and labour to ensure its success, and be supported in their respective countries by departments which realize that practical international action and agreement is a fundamental part of any good State public health policy. As regards countries within or associated with the British Empire we have every reason to anticipate that this support will be given in the Dominions, India, and Egypt, as well as at home.

As I have said so much about this new organization it is only fitting that I should conclude by reference to a few of those to whom the fact that it has now been established by resolution of the Assembly is mainly due. These preliminary steps have not been achieved without labour. Many of us have worked hard at the matter at the Ministry of Health, and much is due to our French colleagues, M. Brisac and Dr. Bernard; to Dr. Lutrario, the chief of the Public Health Service in Italy; to Dr. Hugh Canning, now head of the United States Public Health Service; to the Japanese representation; and especially to the principal officers of the Secretariat of the League of Nations and of the Office International d'Hygiène Publique, all of whom originally took part in working out the main lines in 1919 at the London Conference under the guidance of Lord Astor. At the Assembly itself the scheme was fortunate in having such able exponents as the Right Hon. G. L. Barnes, M.P., the delegate for Great Britain, and Monsieur Gabriel Hanotaux, for France; their statesmanship and industry piloted it past the not inconsiderable difficulties inherent in the first establishment of technical organizations by the League, and in the official requirement that resolutions of the Assembly can only be obtained by a unanimous vote of all the nations represented.

A NEW PRINCIPLE IN THE SURGICAL TREATMENT OF CONGENITAL CLEFT PALATE, AND ITS MECHANICAL COUNTERPART.

BY

H. D. GILLIES, C.B.E., F.R.C.S.

OF THE QUEEN'S HOSPITAL, SIDNEY HILL, AND DEPARTMENT OF CLASICAL SURGERY, PRINCE OF WALES HOSPITAL, LLEYNHAM, AND

W. KELSEY FRX, M.C., M.R.C.S., F.D.S.

OF THE DENTAL PROSTHETIC LABORATORY, QUEEN'S HOSPITAL,

I.—THE PRINCIPLE.

By H. D. GILLIES.

It is felt that the revolutionary principle outlined below, if adopted by surgeons handling cleft palates, will lead to a very great improvement in the results of these difficult cases. My very limited experience does not allow me to make any sweeping statement of facts. I hope, however, that the correctness of this principle will so appeal to the surgeon that he will seldom attempt to repair the hard palate, and never before the eruption of the permanent teeth.

The ideals to be aimed at are: Perfect speech; perfect mastication; normal nasal respiratory function; and, in so

far as a displaced maxilla causes deformity, a normal bony contour. The success of a palate operation is often gauged merely by the completeness of the surgical closure. This should not be so, as it is hoped to show that successful closure of a wide cleft by any of the present-day operations is incompatible with the full attainment of the above ideals.

Speech.

The factors producing perfect speech are a united soft palate, with its musculature intact, and lying in such a position that it can be raised and pressed against the pharyngeal wall, and can control the amount of air for the post nasal space, together with a shutting off of the oro nasal communication left by the congenital defect of the hard palate. Add to this, but of less importance, a set of teeth in a normal position. How are these factors reproduced in the average result of the three main types of operation at present in vogue—the Brophy, the Lane, and the Langenbeck?

The "Brophy" approximation of the maxilla is usually combined with the "Langenbeck" suture of the soft parts, and the more the cleft is reduced by bony approximation the less is the soft palate displaced forward when sutured, and therefore the better is its subsequent action as to air control. In most operators' hands, however, there is usually some destruction of tooth buds and some permanent displacement inwards of the alveolar arches, and the wider the cleft the greater are these defects of mastication, and to a certain extent of speech and breathing. With this type the best soft palate result is likely to be accompanied by a poor hard palate result, as judged, not by the closure, but by the articulation of the permanent teeth.

The "Lane" type theoretically should produce a good soft palate in addition to a hard palate closure; but too frequently the soft palate is much scarred and tight, and, in addition, lies so far forward in the buccal pharynx that its remaining utility as a speech controller is largely discounted. The hard palate defects of the flap operation are discussed later.

The "Langenbeck" type of approximation frequently results in a good movable soft palate, and a surgical closure of the hard palate; but the wider the cleft the shorter must be the palate, hard and soft, as measured from alveolus to uvula, consequently the new soft palate is in a position anterior to the normal, and by as much as the soft palate is drawn forward its speech control is in proportion adversely affected.

Many of the above defects are frequently counteracted by good orthodontia, massage of the soft palate, speech training, and the natural ability of the patient to overcome obstacles. The majority are not, and the skilled service necessary to these secondary defects is not always available or, if available, effective.

Mastication.

If Brophy were right in his premiss that the width of the cleft equals the spread of the maxillae, then his principle would be correct, but he is not. (See Blakeway. *Lancet*, March 6th and 12th, 1915.) Moreover it is doubtful whether Blakeway's measurements form a true index to the position of the maxilla in regard to the mandible, as a very great percentage, if not all cases of unoperated palates, have perfect occlusion (and so mastication) of all

the permanent teeth except those involved in the alveolar part of the cleft, which in both operated and non-operated cases are displaced. In addition to the tooth buds that may suffer from "Brophy's" wires, the upper teeth are inclined to be displaced inwards by the operation, as performed in this country.

The "Lane" flap taken from the alveolar region most frequently interferes with the normal eruption of the teeth, and in addition the fibrous tissue in the united palate and in the scarred area of the alveolus causes a chronic and contractile force between the two halves of the maxilla, and produces an eruption of teeth whose bite lies well inside those of the mandible—that is, a narrowing of the maxillary arch as compared with the mandibular.

The same malocclusion frequently results also from the Langenbeck type of approximation, where the same contractile force is in play, to a greater or less extent according to the success of the closure and to the width of the cleft. The earlier the hard palate is closed by the Lane or the Langenbeck type of operation, the greater chance has this contractile factor in producing malocclusion. In any case of malocclusion

of the teeth in an operated palate such a serious defect may definitely be assigned to the result of the operation, and would not have occurred had the hard palate been left alone.

Nasal Respiration.

In all three types there is thus a tendency to an undue approximation of the maxillae. Hence a narrowing of the nasal passages. I think that much of the nasal trouble attributed to palate cases is due to the operation of closing the hard palate, and not to the oro-nasal communication. A secondary factor enters this part of the problem, however, in the deformity of the alae and tip of nose so often present before and after the repair of the accompanying hare-lip. A scarred, immobile, and forwardly displaced soft palate must also have its deleterious effects on the upper respiratory mucous membrane. I have also observed in many operated cases a dragging upwards and forwards of the pillars of the fauces and of the important tonsil lying between them. It is not inconceivable that much throat and nose trouble lies at the door of this displaced tonsil, deprived of its normal muscular massage, and so, after the manner of "the house that Jack built," at the door of the surgeon who closed the palate.

Appearance.

Hare-lip deformity not being under consideration, it remains to discuss the effects of the surgical closure of the hard palate on the general facial appearance. Whenever from any of the above causes there is a post-operative and undue approximation of the maxillae, the lip, whatever its other qualities, is liable to be flat, and on a plane posterior to normal. The frontal processes of the maxillae move inwards, and usually backwards, with the displaced bones, and consequently the whole of the lower part of the nose is situated on a plane further back than normal, and gives an appearance characteristically represented in Fig. 1, A and B—an actual case. The cure for this deformity of contour is to be found in the epithelial inlay or buccal skin graft, similar to that described in the writer's book on *Plastic Surgery* (see Fig. 2).

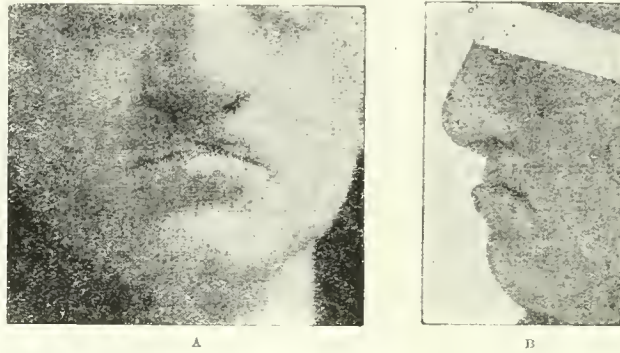

FIG. 1.—Facial appearance of patient following surgical closure of the hard palate. The backward displacement of the lower part of the nose is shown in B.

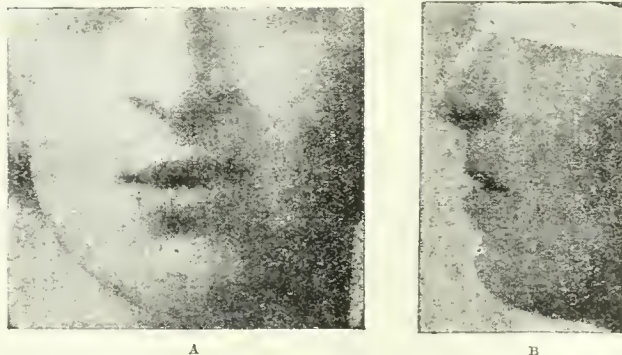

FIG. 2.—Facial appearance following epithelial inlay or buccal skin graft for deformity shown in Fig. 1.

Other Surgical Methods.

The hard palate may be surgically closed by introducing between the two halves of the maxilla, sufficient tissue from a distance to make good the defect; the reader is referred to various neck and other flaps, including the writer's "tubed pedicle," introduced into the buccal cavity, none of which are recommended; and to the introduction into the defect of turbinates and septum grafts, of use in the small defects of the war. It is of significance that Mr. Brophy has on two occasions urged the writer to develop the tubed pedicle method to fill palate defects in lieu of his boue-approximating operation.

Treatment Recommended.

The writer and his colleague, Mr. Fry, consider that closure by means of an efficient dental plate is by far the most simple and efficient mode of treatment; it gives least trouble and provides all that is required of a hard palate as regards feeding, speaking, and breathing, and is applicable in some form or other from earliest infancy. Its very nature prevents any interference with the maxillary growth and eruption of teeth, and saves part of an operation whose mortality is not inconsiderable.

Having decided to make good the hard palate defect by a removable prosthesis, the writer suggests that the two halves of the soft palate be united in as far back a position as is possible. It is not presumed to put forward any fixed operative technique on such flimsy grounds, but the two halves of the soft palate have been separated from the

and caused him to evolve the principles enumerated above, which he hopes may alleviate many of the troubles associated with this condition.

Summary.

All unoperated hard palates have normal occlusion of the non-involved teeth.

Nearly all operated hard palates have abnormal occlusion of the non-involved teeth.

Nearly all operated palates have nasal intonation to speech and narrowed features and nasal passages.

Most unoperated adult cases have enjoyed good health.

Most palate cases require a dental plate, whether operated or not.

Recommendations.—(1) Suture soft palate as far back as possible in the pharynx by detachment from hard, making the hard palate defect greater; (2) fill the hard palate defect by appliance from earliest infancy, even at the bottle or breast stage.

Time for Operation.—Lip, early. Palate, before speech development or later.

II.—THE PROSTHETIC TREATMENT.

By W. KELSEY FRY.

The prosthetic advantages of this combined surgical and mechanical treatment for congenital cleft palates are, first, the ease with which restorations of the hard palate can be performed by prosthetic means as compared with the difficulty with which the prosthetist is confronted in the case of the soft palate; and, secondly, the absence of distortion of the dental arch, with resulting loss of masticatory function, which is unfortunately only too frequent

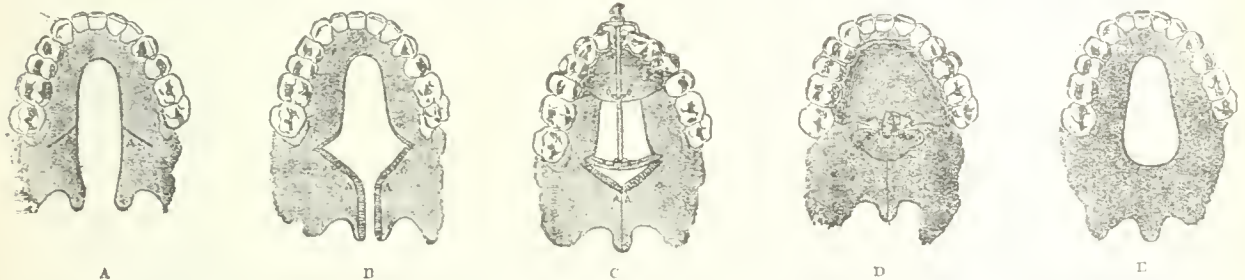

FIG. 3.—Combined surgical and dental treatment of cleft palate. A, Congenital cleft of hard and soft palate. B, Approximation and lengthening of soft palate, which is completely separated from the hard palate. C, Apparatus for the application of skin graft to the raw anterior edge of palate. D, Apparatus by Mr. Fry for stretching soft palate after healing. E, Final result; Hard palate filled with dental appliance; a long movable soft palate which can approximate to pharyngeal wall and give good speech. (Diagrams by S. Horn-wick.)

hard and sutured together after producing two raw edges of apposition. This manoeuvre leaves a larger hard palate defect than prior to operation, and to prevent the raw anterior edge of the newly-made soft palate scarring over and so contracting forward, two methods have been practised—one to take a small flap of muco-periosteum from the hard palate leaving it attached to the soft, and wrap it over the raw area; the other to overlay a skin graft (Thiersch), held in position by an apparatus (Fry, Fig. 3). The latter is more applicable to those cases in which the musculo-mucous-membranous remains of a previously and poorly operated palate have been deliberately detached from a surgically closed hard palate, and made to lie in juxtaposition to the pharyngeal wall. The gap between the hard and soft palate is more efficiently filled by the dental prosthetist than is the usual posterior defect of the soft palate by means of an artificial velum; and the muscular and movable portion of the soft palate works with much greater efficiency as regards speech and deglutition in its new position. The congenital type operation results in a muscular movable soft palate sufficiently near the pharyngeal wall to control air and food, having its palatal aponeurosis represented by the posterior border of the dental appliance, and in a hard palate absolutely closed by the rest of the dental plate. The principle of the treatment of the displaced pre maxilla in double hare-lip cases is one outside the scope of the present article.

If there be any merit in the above principle, the writer wishes to place on record his gratitude for the lessons in facial contour he learnt from Professor H. Tonks of the Slade Art School, and one time war colleague; and especially to Mr. Kelsey Fry for his tactful handling of an enthusiastic surgeon who first wanted to close all traumatic hard palate defects by plastic operations, and later learnt that surgical success was less efficient and far more difficult to come by than the dental closure. This set the writer thinking in regard to congenital palates,

in cases in which the hard palate has been restored by surgical means.

The aims of dental treatment for these cases may be considered under the following four headings:

1. To aid feeding until such time as the surgical operation is thought advisable.
2. To construct an appliance to hold the epithelial inlay in position at the time of operation.
3. To construct an appliance to maintain the surgically restored soft palate in its correct position and, if necessary, to stretch it in a backward direction so as to enable it to make contact with the posterior wall of the pharynx.
4. To construct a permanent prosthetic appliance to restore the loss of the hard palate and, if necessary, the anterior portion of the soft palate.

1. To Aid Feeding until Time of Operation.—When the cleft only involves the soft palate and a small portion of the hard palate, it is only necessary, in order to aid the infant in feeding, to use a specially constructed feeding bottle, by which the liquid is projected into the mouth by means of hand pressure. If the cleft is of a more extensive character, it becomes necessary to construct and fit an obturator on to the teat of the bottle, which will thus prevent food being regurgitated through the nose.

2. To Construct an Appliance to Hold the Epithelial Inlay in Position.—Various types of appliances may be used for this purpose, depending on the nature of the individual case and on the presence or non presence of teeth. The apparatus should be constructed before the operation and should be easily removable. It is also essential that it should be easily adjustable, as it is impossible to locate before the operation the exact position of the anterior edge of the soft palate requiring the skin graft. Fig. 3c shows a general type of appliance which may be used for this purpose.

3. To Construct an Appliance to Maintain the Restored Soft Palate in Position.—When it is only necessary to maintain the soft palate in its new position an appliance

should be constructed which will accurately fit the posterior part of the remaining perforation of the palate and thus prevent it being drawn forwards by any resulting scar tissue. It is essential that this appliance should be constructed as far as possible before the operation, as it is necessary that it should be inserted immediately after the appliance holding the skin graft in position has been removed. In cases where it is necessary to stretch the new soft palate in a backward direction advantage is taken of the fact that the combined action of the muscles of the soft palate is in a backward and upward direction. A prosthetic appliance is constructed which will cause gradual pressure to be made upon the anterior portion of the new palate, thus stretching the soft tissues uniting the hard palate to the soft palate, and allowing the muscles to carry the soft palate as a whole in a backward and upward direction. The appliance should be continued in use until the soft palate is able to make contact with the posterior wall of the pharynx when in contraction, as this state is essential for perfect function of speech. Fig. 3, D, shows the main features of a type of appliance which may be used for this purpose, the details of which vary according to the age of the patient and the number of teeth present.

4. *To Construct a Permanent Prosthetic Appliance to Restore the Loss of the Hard Palate.*—The permanent appliance merely consists of a dental plate which covers over the remaining perforation of the hard palate, except at its posterior border, where it should penetrate slightly into the cavity, thus making sure contact between the soft palate and the prosthetic hard palate, and at the same time preventing contraction of the soft palate. When it is necessary to restore by prosthetic means the anterior portion of the soft palate, this should be done by means of velum rubber, otherwise the whole appliance can be made in hard rubber or a combination of gold and hard rubber.

From the above brief description it will be noted that the permanent appliance necessary in this combined surgical and prosthetic treatment is of very simple construction and of a permanent nature, thus obviating continual dental treatment in after-life.

THE TREATMENT OF SPRUE BY MASSIVE DOSES OF SODIUM BICARBONATE.

BY

ALDO CASTELLANI, C.M.G., M.D., M.R.C.P.,

PHYSICIAN TO THE MINISTRY OF PENSIONS TROPICAL HOSPITAL;
LECTURER AT THE LONDON SCHOOL OF TROPICAL MEDICINE.

In carrying out, some time ago, certain researches on sprue, I noticed that to render strongly alkaline the urine of patients suffering from this malady it was necessary in most cases to give sodium bicarbonate in much larger doses and for much longer periods than in normal individuals or patients suffering from certain other diseases; the alkali tolerance was therefore increased. During this investigation I noticed that the administration of massive doses of bicarbonate, instead of the usual small or moderate doses so often given in the malady, had frequently a most beneficial effect, especially as regards improvement in the intestinal symptoms, and seemed to help greatly the action of the dietetic treatment.

The routine method of treatment I now use in sprue is generally the following: The patient is kept at complete rest in bed and is placed at first on a strict milk diet. The mouth is kept scrupulously clean by using a diluted alum-carbolic mouth-wash.

Glycer. alum	aa	ʒiv
Glycer. ac. carbol.		
Aq. rosae	ad	ʒiv

One teaspoonful to a tumbler of water.

And when painful patches on the tongue are present, a cocaine-carbolic mouth-wash will be found useful.

Cocain	gr.v
Ac. carbol.	ʒj
Glycer. borac.	ʒvj
Aq. rosae	ad ʒiv

Half to one teaspoonful to a tumbler of water.

A mild alkaline tooth paste should be used to brush the teeth with several times daily. Quite a number of private

patients I see come to me toothless; apparently the first advice most of them had received on arriving in Europe was to have all their teeth extracted. I have never seen, in cases of genuine sprue, the course of the disease arrested by such a procedure, and I strongly deprecate it, except in those cases in which the sprue condition of the month is complicated by true severe pyorrhoea. If there is history of recent amoebic dysentery—and this is in my experience very often the case—I give at once a course of six or twelve emetine injections.

In addition to these measures, the patient is placed on an intensive alkaline treatment, which is carried out (a) by giving very large doses of sodium bicarbonate by the mouth, and (b) by intravenous injections of a 2 or 4 per cent. bicarbonate solution.

In a number of cases the administration of large doses of bicarbonate by the mouth is sufficient. It is given in drachm doses, 1 drachm three times daily for the first three days, 2 drachms three times daily for eight or ten days, and afterwards 3 drachms or more three times daily for several weeks. No untoward effects are noticed, but not rarely the patient feels and looks somewhat drowsy for a few days. If the drowsiness becomes marked the dose should be decreased. Papain, takadiastase, pancreatin, etc., may be added to the bicarbonate, but the effect of these digestive drugs is not very brilliant in the acute stage of the malady, and I generally omit them altogether during the first weeks of the treatment; later, such preparations, and especially pancreatic extracts as emphasized by Brown, are useful. When the diarrhoea is very severe 5 to 10 grains of salol may be added to the bicarbonate, but powerful astringents should always be avoided. The addition of a little salol to the powders is also useful when the urine becomes too strongly alkaline. In those rare cases in which there is constipation, magnesium carbonate gr. x-xx may be substituted for salol.

The standard formula of the powders is:

Pulv. cinnamom.	gr.ʒss
Pulv. ipecac.	gr.ʒss
Pancreatin, papain, or takadiastase	gr.ʒij
Salol	gr.v
Sod. bicarb.	ʒij

The powders should be given in half a tumbler of water. The amount of the ingredients should be varied according to the symptoms presented by the patient, as already stated, and some of the drugs (cinnamon, ipecacanha, pancreatin, salol) may be left out altogether. At times in conjunction with the powders I have found it useful to administer bile salts (sodium taurocholate gr. ij in cachets t.d.).

In certain peculiar cases of sprue characterized by severe asthenia and a distinct hyperpigmentation of the skin, in addition to the bicarbonate treatment, I have given adrenalin with good results.

I have used intravenous injections of sodium bicarbonate so far in six cases, always in combination with the internal administration of large doses of bicarbonate as described above. Ten to twenty ounces of a 2 or 4 per cent. solution of bicarbonate is given slowly every day or every other day until twelve injections have been given; then the patient has a rest, but the intensive alkaline treatment by the mouth is continued. After an interval of one or two weeks another course of injections is given, and a third course may be necessary after a further interval. The intravenous injection should be given preferably by the gravitation method, observing all the precautions commonly used in intravenous therapy. In the sterilization of the solution care should be taken to prevent any excessive formation of the carbonate, and this end is best achieved by taking the precautions suggested by Sellard—namely, the bicarbonate solution should be put in strong narrow-mouthed bottles which are filled almost full in order to reduce the air space to a minimum, tightly-fitting stoppers being used. As an additional precaution, these bottles can be sterilized in an atmosphere of carbon dioxide; this can be easily obtained by raising the autoclave to the boiling temperature, while water at the boiling point is provided at the bottom of the autoclave, and a handful of bicarbonate is thrown into the hot water.

I have used the bicarbonate treatment here described in a large number of cases, and in 11, most of them private patients, I have been able to follow the course closely. My experience has been that sprue cases having this treatment, in addition to the usual dietetic measures, improve more rapidly than patients having only the

dietetic treatment, though of course there are exceptions. It is interesting to note that the intestinal symptoms seem to be much more beneficially influenced than the mouth symptoms.

As regards the mode of action of the intensive bicarbonate treatment, I have very few remarks to offer. At one time I believed that large doses of bicarbonate by decreasing the acidity of the intestinal contents might check the growth of monilia fungi, considered by some authors to be the true cause of the malady, and by Low and myself to be merely the cause of certain symptoms, as, for instance, the frothiness of the stools. If recent hypotheses concerning the etiology of the malady be proved correct, then a different explanation will have to be found. At any rate, there appears to be little doubt that in sprue a certain degree of acidosis is often present, and that an intensive alkaline treatment is indicated.

Conclusion.

The administration in sprue of massive doses of sodium bicarbonate by the mouth and intravenously, in conjunction with the usual dietetic measures, gives satisfactory results in a large number of cases, especially as regards the intestinal symptoms of the malady.

ANGINA PECTORIS WITH AURICULAR FIBRILLATION.

BY

HAMILTON M. SANDISON, M.B., CH.B. EDIN.

With a Note by FREDERICK W. PRICE, M.D., F.R.S. EDIN.

THAT auricular fibrillation may coexist with angina pectoris is demonstrated in the case of M., a woman aged 72. The value of digitalis when its administration is controlled, not by its empirical dose but by its therapeutic effect, was evident in the treatment of the case.

M. has suffered more or less all her life from cardiac affection, but, notwithstanding the advice of her physician, has for the past ten years led a strenuous life. On several occasions in recent years, she has been compelled by a feeling of general and cardiac weakness to rest for two or three weeks in bed, and to take 7 or 10 minims of tincture of digitalis thrice daily. She regained strength during these rests in bed, but the action of the heart remained rapid and irregular.

In July, 1920, she had a more serious breakdown, associated with breathlessness on exertion, palpitation, frontal and occipital headaches, and several paroxysmal attacks of pain of varying severity. This pain, undoubtedly that of true angina, was situated in the region of the heart; it was sudden in onset, and associated with a feeling of tightness in the front chest, mental perturbation, intense anxiety, and a sense of numbness in the left arm.

The pulse was completely irregular, with a ventricular rate of 124, many of the ventricular contractions not being registered at the wrist. The systolic blood pressure was undoubtedly raised, most of the beats registering 210 mm.; the wall of the brachial artery was thickened. The left border of the heart was one fingerbreadth outside the nipple line, the right border two fingerbreadths to the right of the sternum, and the note in the neighbourhood of the junction of the manubrium sterni and right intercostal cartilages and spaces was impaired. There was an apical systolic murmur, propagated to the axilla, and the second sound in the aortic area was rather accentuated. There was an absence of albumin in the urine.

Dr. Frederick W. Price, who was called to see the case, confirmed the diagnosis of auricular fibrillation and true angina pectoris. It is accordingly of special interest to find that in the chapter on auricular fibrillation in his valuable work *Diseases of the Heart*, he states: "It would appear, however, that patients suffering from auricular fibrillation are exempt from definite attacks of angina pectoris." Dealing with the etiology of auricular fibrillation, in the chapter referred to, two main groups of cases are described: "(1) Those with a history of rheumatism, and (2) patients suffering from myocardial degeneration. In the case of the former the condition occurs more commonly in early adult life, and the patients frequently have valvular disease—more often mitral than aortic disease, and more especially mitral stenosis. In the second group of cases the condition is more common after middle age." M.'s case probably belongs to the first group,

since there is a definite rheumatic history, and in view of the long duration of the illness and the presence of mitral regurgitation.

The etiology of the angina pectoris is, perhaps, not so certain; but the supernormal blood pressure, the evidence of thickening of the wall of the brachial artery, and the accentuation of the aortic second sound point to arterial degenerative changes, while the impairment of percussion note in the aortic area suggests the possibility of fusiform dilatation of the ascending aorta.

M. was confined to bed for four weeks, and then very gradually allowed to resume a more normal life. Only a very small quantity of fluid was allowed with each meal, and the total intake of fluid did not exceed 1½ pints a day. Tincture of digitalis was administered during the first week in 15-minim doses thrice daily. At the end of the week, as there was no appreciable improvement, the dose was increased to 18 and ultimately 20 minims. During the second week there was obvious improvement, the ventricular rate gradually falling to 84. As there was now some complaint of general depression, headache, and giddiness, the digitalis was stopped for forty-eight hours, and then recommenced in 15-minim doses. It was found possible to continue with this dose, and the ventricular rate ultimately diminished to 74, and the pulse became much less irregular. The systolic blood pressure came down to 180 mm., a drop of some 30 mm. Coincident with the remarkable slowing and steadying of the heart's action there was a most gratifying improvement in M.'s general condition.

Note by Dr. Price.—I desire to express my thanks to Dr. Hamilton Sandison for allowing me the opportunity of reading his notes of this case, which he kindly called me to see in consultation. The case was undoubtedly one of auricular fibrillation and angina pectoris. The first statement quoted by Dr. Sandison from my book was written towards the end of 1917, and represented my experience up to that time. Since then, however, I had observed two cases of auricular fibrillation (proved by electro-cardiographic examination) who also suffered from typical attacks of angina pectoris, before seeing the case of M., which made the third.

ANEURYSM OF EXTERNAL CAROTID ARTERY TREATED BY LIGATURE OF COMMON CAROTID ARTERY AND INTERNAL JUGULAR VEIN.

BY

W. A. PEVERLEY, AND J. K. HAWORTH,

M.B., B.S. DURHAM.

M.S., M.D. DURHAM.

MALVERN, NATAL.

THE following case we think may be of interest and importance.

A Zulu woman, aged about 30 years, came with a tumour of the neck which she said came on after having had a tooth out. There were no signs of injury to her jaw, but she had a swelling the size of a Tangerine orange just below the angle of the lower jaw on the left side. The swelling was expansive in every direction and pulsated visibly. There was a loud systolic bruit over it. The impulse and the bruit disappeared on compressing the artery against Chassaignac's tubercle, and the swelling could be emptied on gentle pressure. It filled up from below on releasing the pressure. The pulsation in the left superficial temporal artery was delayed. The case seemed definitely to be one of aneurysm of the external carotid artery, the only other possibility being a pulsating tumour of the carotid body, and the subsequent history disposed of that possibility.

Following the principle of simultaneous ligature of artery and vein, one of us (Peverley) tied the common carotid artery and internal jugular vein at the seat of election. The after-course was uneventful; the pulsation at once disappeared, and now, six weeks after operation, the tumour is only the size of a small nut, and is hard and fibrous. She had no signs of any cerebral disturbance.

The artery seemed healthy, and she had no syphilitic history, though she had had two stillborn children. A Wassermann test was not done.

It does not appear to be the usual practice to tie the vein as well, though Ceci (Paris Surgical Congress, 1904) proposed the theory and Boari (*Policlinico*, 1905) has found it most successful. It is interesting to note in this regard that Lynn and Shipley (Ochsner, *General Surgery*, 1917) carefully avoided tying the internal jugular vein, thinking, presumably, it added to the risk of the operation. The idea of ligaturing the vein as well as the artery in this case was merely an enlargement of Sir George Makins's principle of simultaneous ligature of vein and artery in

war injuries to blood vessels. It is well to remember that the internal jugular vein cannot safely be tied on both sides.

In the cases recorded up to the present there seems to have been marked success and few or no after-effects when the common carotid artery and internal jugular vein have been ligatured simultaneously.

Memoranda:

MEDICAL, SURGICAL, OBSTETRICAL.

HERPES AND VARICELLA.

THE interesting paper by Dr. Carver in the JOURNAL of February 12th induces me to send notes of a case which has come under my notice.

A child aged 7 years was brought to me with severe herpes of the great and small sciatic nerves. There were large confluent masses of vesicles on the right buttock and sacrum to the middle line, down the back of the thigh to the ham, and a few vesicles on the foot and between the toes; the leg below the knee was livid and oedematous. On about the third or fourth day isolated vesicles appeared on the face and forehead, one on the mucosa at vestibule of nose, a few on the trunk and arm, and one on the left leg. These vesicles appeared first as inflamed pimples, then became distinct vesicles which dried up, leaving a small scab. In appearance they were exactly like the pocks of chicken-pox, and if taken by themselves would have been enough to diagnose a mild attack of this disease. The pain in the leg affected was very intense.

Enfield.

FRED. TRESILIAN, M.D., F.R.C.P.

THE following note may be of interest in view of Dr. Carver's letter in the JOURNAL of February 12th:

An only child had well marked chicken-pox, the rash appearing on January 16th last. On February 7th the grandfather, who lives in the house, developed a small "herpetic" eruption over the second costal cartilage on the left side and an isolated spot above the left sternoclavicular joint. None of the spots became very vesicular. This would be a converse instance to that mentioned by Dr. Carver. The interval was twenty-two days from the appearance of the chicken-pox, but being an only child there was no real isolation.

Monkstown, co. Dublin.

R. L. HEARD, M.B.

THE following cases have some bearing on the alleged association of herpes and varicella:

1. An elderly lady had shingles in 1903. Six weeks after her attack commenced her daughter and son-in-law, who lived with her, were taken ill on the same day with an eruption which their doctor diagnosed as small-pox. The diagnosis appears to have been made because there was an epidemic, supposed to be small-pox, at Cambridge, and the man occasionally travelled in a train which came from Cambridge. As the wife was not exposed in the train, and she and her husband developed the rash on the same day, it seems reasonable to suppose they were infected from the same source—that is, by the patient with shingles.

2. A child, aged 6, living in an isolated country house in a park, developed varicella in April, 1919. The only possible source of infection was that he had, two weeks before, visited a house where the farmer's wife was suffering from shingles.

3. A lady developed shingles on December 29th, 1919. On February 8th, 1920, one of her children, aged 5, developed varicella, and a fortnight later her other two children followed suit. There was no other possible source of infection to be discovered. The interval between the incidence of shingles in the mother and chicken-pox in the child was forty-one days, but the child was not necessarily infected at the commencement of the mother's illness.

4. A boy, aged 14, in March, 1920, caught varicella from his brother, and infected his sister. He had a few vesicles scattered over his body, but between the fourth and tenth left ribs posteriorly was a very copious eruption resembling an extensive eruption of herpes. This looks like a connecting link, as there was nothing to explain the localization of the rash in this neighbourhood.

Bedford.

W. GIFFORD NASH, F.R.C.S.

In view of the interest excited by the paper of my friend Dr. Carver in your issue of February 12th may I record the following facts?

On January 29th I was attacked with herpes of the left musculo-spiral nerve. For two days previous to the onset of the rash I had some considerable smarting and constant pain all along the course of the subsequent site of the rash, especially at night, and during that period I was convalescing from a rather heavy nasal catarrh.

On February 14th my wife developed varicella, at which time she was convalescing from a severe nasal catarrh. The symptoms and course of this ailment were typical, and I think that it is almost the severest attack of varicella I have seen in my thirty-eight years of medical practice. The rash was profuse and covered practically every part of the body, including the soft palate and pharynx. Thus my wife contracted the varicella sixteen days after I developed herpes, which agrees with Dr. Carver's statement.

Years ago Hilton Fagge stated that varicella rarely occurred in children over the age of 10, and that most writers stated that they had never seen it in adults. It seems to me that the chief point of interest in these cases hovers round the question as to whether this disorder really is varicella, or whether it is not some modified form of herpes zoster. Can anyone tell me if any such cases of herpes-varicella infections have been recorded as occurring in children? We know that herpes zoster is not uncommon in children, and although I have seen a good many cases of varicella in my time, I do not recollect having ever seen a herpes-varicella infection in childhood, and but one other case in adults.

It is, I think, agreed that whereas the fluid from even the mildest eruption of variola is capable of conveying the disorder by inoculation, all, or almost all, attempts to inoculate varicella in the same way have failed. Has any attempt in this direction been made with the fluid of herpetic eruption, and if so, what has been the result? Has it produced herpes or varicella, or has the result been nil?

I may say, in conclusion, that I had not attended or been in contact with a case of herpes or varicella for a considerable time, and my wife, so far as she is aware, had not been in contact with any case of varicella, nor had she varicella during childhood.

Torquay.

G. YOUNG EALES, L.R.C.P., M.R.C.S.

THE following cases have just come under my care, and in view of recent memoranda on the subject in the JOURNAL, I send particulars:

On January 8th last Mrs. B., aged 44, consulted me. She complained of pain in the right arm of a sharp, shooting character, which commenced about the middle of the upper arm, and radiated into the axilla and back of the shoulder. On examination I found a widely distributed and well-marked rash of herpes zoster with clusters of vesicles on the back of the shoulder, inner aspect of upper arm, into the axilla, and on to the chest. On January 22nd her son, aged 13 years, developed typical chicken-pox of a somewhat severe character. The following day the other boy, aged 14½ years, also showed marked chicken-pox.

There was no chicken-pox in the district, none reported from the school attended for two years past, and no trace of contact whatever.

This occurrence would appear to strengthen the contention that there is a common infective agency in herpes and varicella. Another observation common to both is that seldom or never is there intercurrent affection or complications in either disease, and any fatality *per se* I should think does not exist. In passing, it is of a little interest to note that both the boys above referred to, now strong sturdy youths, were born in Guy's Hospital by Caesarean section.

J. GORDON McDUGALL, M.B., Ch.B. Edin.

Chadwell Heath.

FROM time to time cases have been reported in which an eruption of herpes was followed within a few days by varicella. Such a case occurred here some weeks ago, and in view of the discussion at present proceeding as to whether there is an etiological connexion between these conditions, it may be pertinent to publish it:

On January 24th a little boy, W. J., was brought to the out-patient department of this hospital for circumcision; when his clothes were removed a typical group of herpes zoster vesicles was found on the left side of the thorax about the sixth intercostal space; the rest of his body was carefully examined for spots, but none were found. His temperature was taken and found to be 98.4° F. Two days later a varicella rash appeared on his chest and back, and his temperature was then 100° F. The eruption was moderately abundant, and the case subsequently ran the ordinary course of varicella.

Inquiry from the mother revealed the fact that a younger brother had had chicken-pox three weeks before; no person in the household was known to have had herpes.

J. P. MARTIN, M.A., M.B., B.Ch.

Royal Southern Hospital, Liverpool.

Reports of Societies.

"TWILIGHT SLEEP."

At a meeting of the Edinburgh Obstetrical Society, held on February 9th, Dr. WILLIAM FORDYCE, President, in the chair, Dr. F. W. N. HAULTAIN read a paper on the above subject. Some years ago with Dr. Swift he published the highly satisfactory results of the management of labour under "twilight sleep" in the Edinburgh Maternity Hospital. Since that time a considerable diversity of opinion had been expressed both by the medical profession and by the lay public as to its merits. Though as a rule admitting its benefits, the medical profession had found the supposed difficulty of its adoption in private practice a serious drawback. With the lay public it had been a theme of discussion of the bitterest character. Its ardent opponents had decried it as a most dangerous procedure fraught with the most appalling results. Since his previous paper, he had employed it in every case where the consent of the patient, hospital or private, was obtained—about 800 in all. The results had been correspondingly satisfactory in both. On this occasion he would restrict himself to an account of its employment in private practice. In his last 150 cases thus treated 70 were primiparæ and 80 multiparæ. In the former there was complete amnesia in 80 per cent. and partial in 20 per cent. In multiparæ the amnesia was complete in 50 per cent., partial in 30 per cent., and no effect in 20 per cent., due to insufficient time for the action of the drug to take place, the labour having terminated so rapidly. The treatment adopted in every case was the same. Morphine $\frac{1}{4}$ gr. and hyoscine $\frac{1}{50}$ gr. was given by injection in primiparæ when labour was fairly established with pains regular and recurring every ten minutes, and in multiparæ whenever definite labour pains were first felt. The patient was put to bed in a darkened room and her ears stuffed with cotton-wool, so that her attention might not be attracted by anything. After three-quarters of an hour a further injection of hyoscine gr. $\frac{1}{50}$ was given, and repeated every hour until labour was completed. If she became noisy or restless after the second stage was reached, chloroform was given during the pains, as from the absence of self-control she might be difficult to manage. After the child was born it was immediately removed to another room to prevent its cries from disturbing the mother during the third stage. She was allowed to sleep till the effects of the drug had passed off; this usually took place in about six hours. When she awakened she was usually unaware that she had ever been in labour.

The largest number of doses given was fifty-three to a primipara with a rigid cervix and strong labour pains, whilst the smallest number of doses which induced complete amnesia was four. It was practically impossible to gauge the amount of analgesia, as the feelings of the patient could not be strictly estimated while under the effect of the drug, and the description afterwards was not to be depended on. Dr. Haultain had little doubt that nearly all suffered discomfort during uterine contractions, which often made them noisy and restless, but of which they had no memory afterwards. It was essential to remember the absence of mental control, as much shouting and restlessness, though it conveys the impression of great suffering to attending friends, was out of all proportion to actual sensation. The feeling of well-being shortly after the delivery was over was perhaps one of the most striking beneficial actions, and tended to endorse the absence of conscious suffering. The effect varied in individuals, hence the acute differences of opinion in both medical and lay minds, and the bitter controversy that existed, and the impossibility of giving a definite opinion without practical experience.

Amongst obstetricians this treatment had been decried in private practice on account of the impossibility of giving personal supervision. This, of course, was necessary if the rules of Gauss were closely followed; he regulated the doses by the memory test. For practical purposes such a regulation of doses was unnecessary. The simple rule of giving an injection of $\frac{1}{4}$ gr. every hour, though perhaps not so scientifically perfect, was sufficient to obtain the benefits required without danger. This could be

done by an intelligent nurse in telephonic touch with the doctor.

So far as his experience showed there was no risk either to mother or child. The latter in 3 per cent. was born oligopnoeic—that is, of a blue colour and with very shallow breathing. In each of these cases it recovered spontaneously without treatment of any kind. In four cases the child was born asphyxiated; three of these were after hard forceps traction, and one in a breech presentation with slight delay in birth of the after-coming head. One child was born dead after craniotomy, having had twenty-three doses to favour head moulding. The patient had had two subsequent healthy children under twilight sleep, labour having been induced at the end of the eighth month. No complications were noted that could possibly be attributed to the treatment. In 6 cases labour was induced, and in none of these did the child appear affected by the drug. Forceps were applied thirty-nine times in the 70 primiparæ and twice in the 80 multiparæ. This he did not consider more frequent since the use of scopolamine, as he had always followed the rule of using forceps if the head was in the pelvis and the second stage had lasted more than three hours in a primipara and two hours in a multipara. In minor degrees of pelvic contraction he preferred to wait much longer, to permit of head moulding, and in these cases scopolamine was of the greatest advantage in diminishing the suffering during the long second stage. He had twice observed patients become so unruly as to be maniacal, trying to bite and refusing to lie in bed. In these cases chloroform was administered deeply and it quickly controlled the symptoms. Occasionally with a long labour he gave a further $\frac{1}{2}$ gr. morphine, where much restlessness was experienced before full dilatation of the cervix. Morphine had been credited with being the cause of the oligopnoea. This he was not prepared to admit, as very much larger doses were given in eclampsia without such evil effects.

Dr. BALLANTYNE had not used this method much in private practice because early in his experience with it he had had a stillborn baby, and though he could not say definitely that twilight sleep was the cause of death, he had been very careful about using it since. Careful records had been kept of its use in 320 cases in the hospital, and with the exception of vagaries in some of the patients' behaviour, and some difficulties in resuscitating the babies, it was very successful. He had noticed that where the primary dose of morphine and scopolamine was followed by the birth of the child about $3\frac{1}{2}$ hours afterwards these babies were difficult to resuscitate. Where the labour occurred either under two hours or was considerably later than $3\frac{1}{2}$ hours after the primary injection, there was no difficulty at all. If the infants continued longer in the uterus the effects of the morphine wore off, and if they were born before two hours the morphine had not had time to have a bad effect. He had formed the opinion that the method was a valuable adjunct to chloroform, and it had the advantage, unlike chloroform, of being useful during the first stage of labour.

Dr. HAIG FERGUSON agreed with all that Dr. Haultain had said regarding the use of twilight sleep in private practice. It was not so valuable in hospitals, where the bustle and commotion incidental to hospital work were against its success.

Dr. LAMOND LACKIE gave the statistics of the use of twilight sleep in 91 cases in the Edinburgh Maternity Hospital. The initial dose was morphine $\frac{1}{4}$ grain and hyoscine $\frac{1}{50}$ grain. As regards subsequent doses, $\frac{1}{50}$ grain of hyoscine was repeated every hour till the head was on the perineum; $\frac{1}{4}$ grain of morphine was repeated in only a few cases. No patient had more than twelve injections and the average number of injections was seven. The results in regard to the mother were good. As regards the children, in 77 cases—that is, 84 per cent.—there was no bad effect. In 9 there was slight cyanosis—that is, 10 per cent. Prolonged artificial respiration was required in 3 babies—that is, 3.3 per cent. In 2 cases there was no apparent cause, in the third the child was born within two hours of the last injection of morphine. There had been two deaths, but in one case version was performed and in the other craniotomy.

Dr. RONALDSON had used hyoscine for the last ten years in private practice, and in practically every case, and he would as soon think of going without it as without chloroform.

Dr. FLETT said he had found the method of enormous benefit in general practice, and if one had an efficient nurse it could be given in every case.

Dr. HENDRY (Glasgow) did not agree with Dr. Haultain regarding the definite interval administration of the drug without any reference to the condition of the patient, because he found that patients were susceptible to scopolamine in very different degrees.

Dr. R. W. JOHNSTONE agreed that twilight sleep was a valuable addition to the methods of treating labour. The best results were obtained when the doctor was in fairly constant attendance, and where the dose was regulated by the patient's reaction.

Dr. F. J. BROWNE, during his work upon stillbirths, had found, out of 300 necropsies, four cases in which he considered himself justified in putting down the cause of the death of the child to morphine-scopolamine narcosis.

Dr. KEMPE PATERSON said he had given up twilight sleep in practice because of one unfortunate experience with the child.

EXOPHTHALMIC GOITRE.

THE discussion on exophthalmic goitre in the combined meeting of the Clinical Section of the Royal Society of Medicine with the Sections of Medicine and Surgery, which was adjourned from February 11th, was resumed on February 25th, Sir ANTHONY BOWLEY presiding. A report of the opening of the discussion appeared in the BRITISH MEDICAL JOURNAL of February 19th at p. 268.

Mr. DONALD ARMOUR, who dealt with surgical treatment, objected at the outset to the terms in common use for describing the disease, and urged that a wider use be made of the term "hyperthyroidism." He said that in operating he had always used a general anaesthetic. The anaesthetic bogey was disappearing, but it looked like being replaced by another bogey—namely, the possibility of damage to the recurrent laryngeal nerve. This danger need not arise if care and gentleness were exercised in operation. The ligation of arteries had a definite place among the operative procedures. He had been impressed by the excellent results obtained from ligation alone. The ligation of the vessels and the removal of more or less of the gland substance were the only two operations which should have any place in the surgical treatment of the disease.

Dr. FLORENCE STONEY gave particulars of some 200 cases which she had treated by *x* rays during the last thirteen years. Of these, 78 were quite cured and strong after a long interval since cessation of treatment, 66 were much better, 28 were no better; many of the others had been lost sight of. *X*-ray treatment should only be entrusted to a first-class radiologist. If time was of vital importance in any case, surgery might offer the greater advantage; in all other cases *x* rays should be preferred, since they spared the patient the mental upset of operation, sometimes repeated, as well as the pain and risk to life. The disadvantages of *x* rays were the tediousness of treatment—largely obviated by taking the disease in hand early—and the occurrence of telangiectasis and scars, both of which, however, occurred less and less frequently with improvement in technique.

Dr. J. M. H. CAMPBELL brought further up to date Sir William Hale-White's analysis of the after-history of cases at Guy's Hospital. During the ten years 1908-17 reports were available of 127 cases at Guy's, of which 80 or more had been traced, while 8 had died in hospital either from the exophthalmic goitre itself or from terminal affections while this condition was acute. Of the cases traced after discharge, 7 were found to have been completely cured, 26 almost cured and able to live a normal life, 29 much improved and able to do light work, and 11 improved slightly or not at all. A comparison of the results of surgical and medical treatment—the former only applying to a small number of cases—showed much the same proportions in each of these four groups.

Mr. W. H. C. ROMANIS discussed the selection of cases for operation. If all the signs and symptoms were slight and not progressing, medical treatment was often followed by benefit. In moderately severe cases or cases in which any one sign or symptom was present to a marked degree, medical treatment should not be continued for more than two or three months at most. Operation should not be urged in those cases where the patient was very unwilling to undergo it. The removal of large portions of the thyroid

gland was the procedure which gave the best results. One lobe, the isthmus, and a quarter of the other lobe was the minimum which should be excised. After thyroidectomy it was very common to find a greater improvement in the subjective symptoms than in the physical signs.

Mr. A. J. WALTON spoke of the results in 101 cases in which operation had been done; 52 were completely cured, and 23 relieved, and there were five deaths. These were selected cases in the sense that they had all received medical treatment; they were the failures of medical treatment. It was his custom never to operate on cases during the first six months. His opinion of *x* ray treatment was unfavourable. He advocated medical treatment (1) if the symptoms had been in evidence for less than six months; (2) as a preliminary to surgical treatment; (3) before a second operation in a case of relapse, where there was an enlargement of the remaining portion of the thyroid after operation. He divided the disease into three groups: the type which was predominantly vascular, the type which was predominantly nervous, and the type in which hyperthyroidism was in association with adenomata. The last ought not to be included with exophthalmic goitres. The vascular type did extremely well after operation, the nervous type not so well, though he thought operation should be done. He always did a partial thyroidectomy; he had never done ligation of the artery, though he did not condemn that operation.

Mr. J. E. ADAMS thought that the unfortunate results obtained by surgery in the past were due to the use of chloroform as the anaesthetic, and to the failure of surgeons to recognize the necessity for gentle handling in thyroid surgery. The great merit of local anaesthesia was that it compelled the surgeon to be gentle. He suggested that radium therapy might be combined with surgery. A hemithyroidectomy might be done under local anaesthesia, followed by the burying of radium in the wound for a number of hours.

Dr. F. HERNAMAN-JOHNSON was doubtful if *x*-ray treatment, unless used in large doses, had any inhibitory effect on the gland, yet its beneficial influence was very marked in many cases. He believed that the good effects were constitutional rather than local, were general and not specific. Small and frequent doses were necessary, at any rate at the beginning of treatment. In difficult chronic cases it might be well to use galvanism as well as *x* rays. *X* rays and electricity were part of the medical treatment of exophthalmic goitre, and the time to call in their aid was when the disease was first noticed.

Professor H. G. EARLE gave a short description of the basal metabolism test for hyperthyroidism, demonstrated an instrument, and showed a number of graphic tracings of the measurement of oxygen consumption.

The discussion was then further adjourned until Friday, March 11th.

CONGENITAL SYPHILIS.

A discussion on congenital syphilis, its diagnosis and treatment, was opened on February 25th at the Royal Society of Medicine, in the Section for the Study of Disease in Children, with Dr. FREDERICK LANGMEAD in the chair.

The Limits of the Wassermann Reaction.

Sir HUMPHRY ROLLESTON restricted his opening remarks chiefly to the suggestion of lines for discussion. He spoke first of the limits of the Wassermann reaction as a means of diagnosis, and then of the influence of congenital syphilis in favouring the onset of other infections, in leading to changes in the endocrine glands, and in bringing about other conditions not generally regarded as being due to syphilis nor obviously connected with endocrine gland lesions. With a certain number of exceptions, most of which hardly came within practical range, a positive Wassermann pointed to the presence of active syphilis and to the need for antisyphilitic treatment, but the converse did not hold good, and the question for consideration was, in what circumstances should they hesitate to accept a negative Wassermann as evidence that syphilis was absent and treatment unnecessary? The syphilitic infection, after severely damaging an organ, might die down or die out, and although its past effects were obvious, it was no longer an active factor. In such cases, if the

Wassermann test was negative, it might logically be argued that antisyphilitic treatment was unnecessary; the conditions which he had in mind were insufficiency of the glands of the internal secretion and of the blood-forming organs. Was a negative Wassermann of the blood to be regarded as final evidence that antisyphilitic treatment need not be undertaken, and that the possibility of further activity of the spirochaete, perhaps on the endocrine glands already affected, could be ignored? He suggested that at present it was impossible to adopt as an absolute proposition that in the presence of syphilitic stigmata a negative Wassermann eliminated the possibility of existing syphilis.

Remoter Effects.

In the second part of his remarks Sir Humphry Rolleston pointed out that congenital syphilis was a factor disposing to other infections. A number of acute infections were so well marked as often to mask the underlying syphilis. The influence of syphilis was also very important in the causation of lesions of the endocrine glands, and so indirectly of syndromes which were not necessarily characteristic of syphilis. The pituitary body might be infected, and its infection might perhaps be accompanied by a negative blood Wassermann, although a cerebro-spinal Wassermann might be positive. Among various other conditions, obesity was seldom recognized clinically as a result of congenital syphilis; nevertheless it occurred. Another problem of extreme difficulty was the part which insufficiency of the endocrine glands played in some of the obscure bone diseases. There were at least three ways in which congenital syphilis might be imagined as giving rise to chronic interstitial nephritis: by means of the fibrotic process following on an acute interstitial nephritis, by the production of arterio-sclerotic kidney, and as a result of damage to the endocrine glands, the last having a definite bearing on infantilism. No discussion of the remote effects of congenital syphilis would be complete without a reference to rickets, and he touched in passing on the recent interesting suggestion that syphilis so damaged the endocrine glands that the bones were sensitized to such immediate causes of rickets as diet deficiency.

Surgical Manifestations.

Mr. O. L. ADDISON, who opened the discussion from the surgical side, said that the manifestations of congenital syphilis which came to the surgeon were, on the whole, less puzzling than those which came to the physician. The chief factor in the successful diagnosis of most diseases was to be on the watch for them, and it was a commonplace that syphilis was the best masquerader of them all. At present they seldom saw the severe manifestations of congenital syphilis except in infancy, and with antenatal treatment it might be hoped that even in infancy they would become rare. The most constant feature of infantile syphilis was osteomyelitis of the long bones. He had frequently caused radiographs to be taken in doubtful cases to confirm the syphilis diagnosis. The diagnosis offered little or no difficulty if such radiographs were taken. In the second period, following upon infancy, bone and joint affections were still the most marked manifestations. Periostitis was very common from three years onwards, either diffused or localized, and was frequently found in either form on the tibia, though it might occur on the other long bones as well. Mr. Addison showed a large number of radiographs illustrating the various bone conditions. He added that he had only had one case in which he was able to prove the presence of both syphilis and tubercle. He believed in a course of novarsenobillon plus mercury, and of the two drugs he did not doubt that mercury was the more valuable.

Juvenile General Paralysis.

Sir FREDERICK MOTT exhibited some photographs and photomicrographs relating to juvenile general paralysis and tabo-paralysis as a result of congenital syphilis. These included cases of general paralytics as old as 16 years in whom the sexual organs were quite undeveloped. Long ago he was convinced that syphilis was the cause of general paralysis, and not alcohol or sexual excess, or any of the other causes which had been sometimes cited, and he felt that the only way to demonstrate this was to collect cases of juvenile general paralysis and prove their syphilitic origin. About half the cases collected showed definite

signs of congenital syphilis on the body, but the remainder had no signs on the body exteriorly, and he had to get the family history, which he was able to do in the majority of cases. The family history seemed frequently to show a record of three or four miscarriages followed by the birth of a juvenile paralytic. The juvenile paralytic seemed to be the last development of the familial disease. With regard to the infection of the pituitary body, there was no doubt that spirochaetes were in the brain in every case in which there was a positive reaction of the cerebro-spinal fluid, but he had examined some pituitaries and had never seen the spirochaetes in the pituitary body.

The Wassermann Reaction from the Clinician's Standpoint.

Dr. LEONARD FINLAY (Glasgow) said that, although most of the eulogies regarding the Wassermann reaction had emanated from the laboratory, he as a clinician had the greatest faith in the reaction, which for all practical purposes he regarded as specific. He took a number of cases of what might be supposed to be the early manifestation of syphilis—cases of different skin manifestations sent up by his colleagues to the hospital—and divided them into four classes: (1) those which, clinically, were definite syphilis; (2) those with regard to which he was doubtful but was inclined to think syphilitic; (3) those which he was inclined to regard, though still doubtful, as not syphilitic; (4) those which, in his opinion, were definitely not syphilitic. The results of the subsequent Wassermann test were as follows:

	Positive Wassermann.	Negative Wassermann.
Class 1	161	2
Class 2	31	10
Class 3	11	40
Class 4	0	58

The mothers of syphilitic infants showed a positive Wassermann reaction in 76 cases; a negative in 10. He had also analysed the Wassermann reaction obtained in a considerable number of different conditions, and in presenting a list of these he pointed out that of the 13 cases of congenital heart disease included not one showed a positive reaction, and of the 14 cases of marasmus one was positive and the others negative. His general impression from working on Wassermann reactions in a children's clinic was that congenital syphilis was nothing like so frequent as was commonly stated. The only way to arrive at a conclusion on the subject would be to obtain the Wassermann reaction in a large number of cases admitted both to the indoor and outdoor departments of the hospital, and so far as he knew, this had only been done in America, where the proportion of congenital syphilitics was stated to be 2 per cent.—meaning 2 per cent. of the ailing child population only. If a positive Wassermann spelled syphilis, a negative Wassermann spelled no syphilis—at least, in the presence of no active manifestations. He condemned treatment by mercury alone: 70 per cent. of the children he had treated in the old days by mercury alone had died, but with the introduction of salvarsan and its administration along with mercury (he never used salvarsan alone) the mortality fell at first to 36 per cent. and later to 26 per cent. He had had a good many accidents when attempting to give salvarsan intramuscularly, and preferred the intravenous method of injection. With regard to ante-natal treatment, not only was the child who was born immediately after a course of treatment healthy, but children born subsequently of the same mother appeared to be healthy too. He advocated the encouragement of ante-natal treatment by, among other means, the compulsory notification of miscarriages and stillbirths.

Ante-natal Treatment.

Dr. AMAND ROUGH said that about 16 per cent. of infantile deaths were due to congenital syphilis, and he pointed out that the reduced infant mortality for the years 1917-19 did not hold good so far as the early weeks of the infantile year were concerned. He doubted whether early syphilitic abortions could be prevented by ante-natal treatment with salvarsan, partly because the diagnosis of pregnancy could not be obtained early enough, and partly because, if the infection was sufficiently active, the delicate embryo would be destroyed. With our present knowledge, congenital syphilis could be prevented or cured if every syphilitic mother were treated, not only during pregnancy,

but in anticipation of her next pregnancy, especially if the treatment of the child were continued after birth; for it was clear that the most serious cases of embryonic infection would terminate in abortions or still-births, and that almost all other cases, owing to the infection being latent, were amenable to treatment during pregnancy. To begin the treatment of a congenital syphilitic child only after its birth, when it had probably a positive Wassermann reaction, was very rarely effectual.

Results of Treatment of Children.

Dr. D. N. NABARRO related some of his experiences at the venereal diseases clinic at the Children's Hospital in Great Ormond Street. He said he was in the fortunate position of himself doing the Wassermann tests as well as treating and watching the cases. He was convinced that the Wassermann was an extremely valuable test when reliably done, but it was often not done reliably. During last year he had treated 77 patients with 530 injections. The injections (of, until this year, novarsenobillon) were always made, if possible, into the veins. Several children had had from 18 to 24 injections. He had no doubt that many children had benefited considerably from the treatment. In three interesting cases ulceration of the palate had healed up. He was not sure that, in eye treatment, the condition of keratitis had been shortened. Periostitis had cleared up in a remarkable manner. A certain number of mentally defective children became definitely brighter. But, in his experience, the immediate results in the treatment of congenital syphilis were not so dramatically obvious as in the primary and secondary stages of the acquired condition; and many of the cases died. Of a group of 62 children treated last year, 14 became negative; but of these 14, 5 had again become positive.

Statistics of Blind Children.

Mr. BISHOP HARMAN described the associated symptoms found in 600 cases of children blinded from the effects of congenital syphilis. He stated that the cases were the collection of seventeen years, that they had been under his care for an average time of six years, so that there was ample opportunity for observation. Dividing the cases in two groups as the front or back parts of the eyes showed the most manifest inflammatory effects, he found 393 cases of interstitial keratitis and 229 cases of disseminated choroiditis. Amongst the group of interstitial keratitis the main associated symptoms were: Hutchinson's teeth 265, characteristic physiognomy 115, iritis 128, bad family history 170, scarred mouth 61, bone or joint disease 26, ulceration of nose or palate 15, deafness 63. Among the group of disseminated choroiditis, numbering 229, there was optic atrophy in 117, Hutchinson's teeth 97, physiognomy 53, bad family history 115, bone or joint disease 19, deafness 51. Comparing the frequency of the chief associated symptoms of the two groups it was found that the characteristic teeth were present in 73 per cent. of keratitis and in 46 per cent. of choroiditis, bad family history in 47 per cent. of keratitis and 55 per cent. of choroiditis, gross mental disorder in none of the keratitis cases but in 41 per cent. of choroiditis. Bad family history was shown by the high rate of miscarriage, still-birth, infant death, and diseased children. Among 150 syphilitic mothers there were 1,001 pregnancies with only 390 presumed healthy children. Amongst 150 average hospital patients who were mothers there were 826 pregnancies with 654 healthy children, or 792 per 1,000, so that the average mothers produced twice as many presumed healthy children as the syphilitics. Mr. Harman advocated the value of ante-natal treatment.

The discussion was adjourned until March 16th.

ANAESTHETICS IN PLASTIC SURGERY.

A MEETING of the Section of Anaesthetics of the Royal Society of Medicine was held on February 4th, with Dr. SHIRLEY, President, in the chair, and a paper by Messrs. ROWBOTHAM and MAGILL on "Anaesthetics in the plastic surgery of the face and jaws" was read, based on 3,000 cases at Queen's Hospital, Sidcup. After alluding to the physical and mental peculiarities of the type of patient and to the number of times each of them generally required an anaesthetic, the authors divided the cases into those in which the anaesthetist has control of the mouth

and those in which he has only the nose at his disposal. In all cases the main difficulty is that of maintaining a proper airway. When the mandible is altogether or largely missing a long blunt instrument is employed through the mouth to hold up the base of the tongue during induction. Technique was described rendering possible the use of nitrous oxide for induction in patients with broken or abnormal jaws. Intratracheal infiltration proved to be the most generally applicable method. The authors had devised means for employing gas and oxygen with this method, generally combining the gases with small amounts of ether. The methods of passing the catheter through the nose and guiding it into the larynx by specially devised instruments were described. Frequently dilatation of the nares by a series of tubes was required, and often a tube was used through each nostril. The use of nitrous oxide, with or without the aid of local infiltration, was described in connexion with superficial flap operations. The necessary steps were described for avoiding chest complications, which are to be feared owing to the length of time required by most of the operations dealt with. These averaged one and three-quarter hours and were often over three hours. In 1,700 cases there had been only four instances of bronchitis and two of pneumonia.

In the discussion which followed, Mr. H. E. G. BOYLE feared that the dilatation of the nose as described was very likely to cause bleeding. His own experience of passing nasal tubes was that although one side of the nose was usually free it frequently happened that it was almost impossible to pass a second tube through the other nostril. He believed that colonic oil ether anaesthesia was too uncertain for the class of case discussed, and also that the long unconsciousness afterwards was a drawback. His present preference for these operations was a combination of gas and oxygen and CE mixture. Mr. RAMSEY PHILLIPS pointed out that a catheter passed through the nose could usually be guided into the larynx by altering the position of the patient's head without using an instrument through the mouth. Dr. W. J. McCARDIE said that in a large experience of the kind of case dealt with by the authors he had used very simple methods. Nasal or oral intubation with "draw-over" inhalation from a mask or plain gauze had generally given good results. Nasal tubes should have large lumen and be comparatively stiff. There were certain advantages in the use of chloroform for these cases, such as little oozing and quiet respiration and circulation. Mr. KIRKBY THOMAS said that he induced with CE mixture from an open mask, passed a wide rubber tube down into the pharynx and packed this round with gauze, and then passed the delivery catheter of a Junker's inhaler into the tube. The catheter was kept in position by pressure against a safety pin transfixing the pharyngeal tube. Dr. F. E. SHAWBY considered intratracheal ether far superior to the elder methods for these free operations. Nasal tubes frequently caused damage with considerable bleeding, and he believed that there was a risk of conveying septic infection if a catheter were passed through the nose into the trachea. Mr. C. W. T. HINSON described a tap for allowing small portions of ether to be taken up when it is required to supplement gas and oxygen with this anaesthetic.

MEDICAL REFORM IN IRELAND.

At a meeting of the Section of State Medicine of the Royal Academy of Medicine in Ireland on January 14th, the President, Dr. R. J. ROWLETTE, opened a discussion on "Medical reform in Ireland." He gave an abstract of the recent report of the Irish Public Health Council, and expressed the opinion that it gave the foundation for a thorough and statesmanlike scheme of reform. Unfortunately the Government had declined to legislate on it, and the Chief Secretary had given contradicting reasons for this refusal. The scheme might, however, form the basis of legislative action when a normal system of Government again existed in Ireland. It was a hopeful sign that those who represented the political opinions of the majority of the Irish people had serious and sound views on health matters. Sir JOHN MOORE, President of the Academy, read a paper on "Existing hindrances to public health work in Ireland," in which he drew attention to the fact that the Infectious Disease

(Notification) Act of 1889 provided that the local authority should pay to the medical practitioner a fee of half a crown for each certificate sent by him in accordance with the Act if the case occurred in his private practice. This provision was endorsed and extended by the Infectious Diseases (Prevention) Act of 1890. The Tuberculosis Prevention (Ireland) Act of 1908 provided that a fee of one shilling should be paid to the practitioner for certificates in the case of persons treated in public institutions and half a crown if the case occurred elsewhere. The Local Government Emergency Act of 1916 reduced the fee payable for notification to one shilling in all cases. With regard to the sanatorium treatment of tuberculosis, he referred to the extraordinary fact that an *impasse* between the Local Government Board and the local authorities should be allowed to cause serious risk to public health by interrupting the machinery provided under statute for dealing with tuberculosis. Lastly, he pointed out that the recommendations and proposals of the Irish Public Health Council, a statutory body, had been for the time being stultified by the decision of the Government that schemes involving expenditure and not yet in operation were to remain in abeyance.

Mr. BURKE said it was very hopeful to find medical men of the political views and professional standing of Sir John W. Moore and Dr. Rowlette putting Irish public health before every consideration. It was gratifying that such pioneers of public health in Ireland were so explicit in attaching responsibility to the Government for the threatened, and in some places actual, suspension of the health services in Ireland. The present deplorable condition of public health in Ireland was for the most part due to the Government's withholding grants which heretofore were given towards public health administration, but now were diverted to meet the awards for malicious injuries. Dr. MOORHEAD said he had been lately studying the financial position of the voluntary hospitals, and concluded that the only hope for the future lay in some form of State subsidy or grant. He hoped that the voluntary basis would always be maintained. When the combined sums of voluntary subscriptions, payments from patients who were able to pay, and municipal subscriptions were added together, there would still remain a deficit, and this deficit he felt must be made good by the State. Even if this were done it would not be necessary to have State control, for the municipalities that subscribed to the hospitals sent representatives to the hospital boards, who were welcome and most useful members. Similar representatives of the State would add strength to the hospital boards in the future.

Sir WILLIAM J. THOMPSON, Registrar-General, said he did not think even the profession fully realized the amount of invaluable work done for public health by Sir John W. Moore, Dr. Rowlette, and Dr. Alice Barry, who were selected by the Irish medical profession to represent their interests on the Irish Public Health Council.

At a meeting of the Brighton and Sussex Medico-Chirurgical Society held on February 3rd, Dr. W. LANGDON BROWN, discussing types of glycosuria and their treatment, said that although carbohydrate formed more than 70 per cent. of ordinary diet, it only constituted about 1 per cent. of the body; it was, therefore, the most easily metabolized of the foodstuffs, and disturbed metabolism was apt to show itself particularly in respect of carbohydrate. That true diabetes implied a great deal more than a mere disturbance of carbohydrate metabolism was now recognized; it was a disease characterized by exaggerated katabolism, which shows itself first and most obviously in respect of carbohydrates. He then discussed the various ways in which the body normally dealt with carbohydrates, and pointed out that it attempted to compensate for an impaired power to assimilate them (1) by storing more than usual as fat in the earlier stages, and (2) by raising the "leak point" for sugar, thus diminishing its escape. In some persons the leak point was abnormally low, constituting renal glycosuria, which could usually be recognized by the constant output of sugar, irrespective of diet. Since the sugar in the blood and in the urine did not run parallel, owing to variations in the leak point, it was important to know what was happening in the former. A single observation was not much use; it was far more helpful to give a dose of sugar and watch how the body was able to dispose of it by estimating the blood sugar at regular intervals.

Reviens.

BRAIN INJURIES.

The book on *Brain Injuries* by Dr. W. SHARPE, of New York, is divided into three parts, of which the first deals with the diagnosis and treatment of brain injuries; the second with what are termed "acute" and "chronic" brain injuries in adults; and the third with brain injuries in children.

The author rightly insists upon the preponderating importance of the cerebral over the cranial injury, but the main theme, developed at great length and with much needless repetition, is concerned with variations of the intracranial pressure. Almost all the symptoms and sequelae of cranial injuries, whether headache, giddiness, mental deterioration, or even traumatic epilepsy, are ascribed to increased intracranial pressure. The author has a great deal to say about cerebral oedema, but, although its pathology is discussed, no new light is thrown upon it.

The main bulk of the book is made up of detailed descriptions of a very large number of individual cases, with comments thereon. Six pages, for example, are devoted to a single case. Such an arrangement makes it difficult to look up any given point, and this difficulty is not lessened by the index, which might be greatly improved.

Two pages are devoted to cerebral concussion, and these are followed by detailed accounts of a number of clinical examples. Little, however, can be learnt as to the author's views with regard to the pathology of this much-discussed clinical state. He speaks of a "temporary disturbance of the theoretical molecular relationship of the cerebral tissues" and of a "probable combination of an immediate circulatory upset with a greater or less degree of shock." He would appear not to regard as suffering from "true" concussion any patient in whom signs or symptoms of any other form of cerebral injury can be ascertained; "the diagnosis should be made only after all other possible conditions have been carefully excluded." The common occurrence of concussion antecedent to or in combination with any other cerebral lesion does not appear to be recognized.

We have looked in vain for any attempt to discriminate between the now generally recognized types of post-traumatic headache. The pathology of these headaches is not discussed, and they all appear to be ascribed to a general increase of intracranial pressure. Traumatic epilepsy is stated to be "the result of a condition which could have been relieved at the time of the primary cranial injury, and thus the epileptiform convulsions could have been avoided." This view could scarcely be shared by the majority of those with any large experience of traumatic epilepsy. Nor would the method of selection of cases for operation, according to whether the increased intracranial pressure (assumed to be always present) was antecedent to or consequent upon the fits, find general acceptance.

The sweeping condemnation of the closure of cranial defects, and the failure to recognize the symptoms due to the existence of such defects, does not harmonize with the experience which has been gained from the study of the large number of cases resulting from the injuries of warfare. It is not a little surprising that in a book published in 1920 the subject of gunshot wounds of the head should occupy less than two pages.

Perhaps the part of the book which is most open to criticism is that which deals with the alleged advantages of the operation of "subtemporal decompression," particularly in relation to cerebral tumour. It is almost impossible to resist the conclusion that the operation is regarded as a kind of panacea for intracranial lesions. The 73 small pictures which illustrate the steps of the operation show little beyond large numbers of instruments and gloved hands in varying relation with one another. The illustrations throughout are, indeed, not on a high level. For example, the picture on page 92 shows the vortical incision for a subtemporal decompression equal in length to the whole of a hand from finger-tips to wrist.

¹ *Diagnosis and Treatment of Brain Injuries*. By William Sharpe, M.D., Professor of Neurologic Surgery, New York Polyclinic Medical School. Philadelphia and London: J. B. Lippincott Company, 1920. (Med. 8vo. pp. 763; 220 figures, 7 plates. 35s. net.)

Increased intracranial pressure being the keynote of the book and the arbiter of operative treatment, we look for information as to how it is to be gauged. Naturally, the state of the "so-called optic disks" is taken as a guide, and the author rightly draws attention to the fact that within a few hours of an injury the discs often present recognizable changes, the veins being engorged and the edges obscured by oedema. It is not so easy, however, to accept the oft-repeated statement that the intracranial pressure can be accurately measured by means of a mercurial manometer attached to a needle inserted into the spinal theca.

Amongst the results of cerebral injury in children considerable attention is devoted to the treatment of spastic paralysis. The author examined 1,922 children with this condition, and found ophthalmoscopically and by means of the spinal manometer that 368 of them showed definite signs of an increased intracranial pressure; 358 of these patients were operated upon (subtemporal decompression), with a mortality of 10 per cent. "The results have been most gratifying in the younger children . . . not only has there been a lessening of the spasticity of the arms and legs . . . but there has been a definite amelioration in the mental condition." "Even in the older extreme cases the improvement has been most striking."

A GENERAL VIEW OF PREVENTIVE MEDICINE.

THE avowed aim of the authors of the *Principles of Preventive Medicine*² is "to give an outline of the principles and practice of preventive medicine so far as it seems to concern the medical student and the general practitioner of medicine"; they have succeeded in producing a volume of considerable merit and attractiveness. It cannot be described in any way as a textbook, and certainly will not displace the standard textbooks on hygiene which are read at the present time by candidates for a diploma in public health. It contains much of value to the general practitioner and also to that increasing number of lay persons who are interesting themselves in public health matters. They will learn not only what preventive medicine in the widest sense means, but they will discover what preventive agencies are already in being, how their activities are being carried on, and how the official workers may profitably be assisted by the unofficial.

The general arrangement of the book is excellent. Beginning with a chapter upon the English system of local government, there follow in appropriate chronological succession chapters dealing with eugenics and maternity, infant mortality, the welfare of the child from one to five years—the toddler, the health of the school child, and the health of the adolescent and adult. Later chapters deal with housing, food supplies, water supplies, infectious diseases, preventive inoculation and industrial hygiene. More than forty pages are given to a chapter upon vital statistics in which the elementary principles are very clearly put, and the reader is gradually introduced to more complex phases of the science. In the preparation of this chapter the authors acknowledge the assistance rendered them by Dr. Major Greenwood. The chapter upon preventive inoculation describes with great clearness and simplicity the theory of immunity, and deals with the various methods for the production of artificial immunity. When discussing the subject of alcoholism, the authors express temperate opinions.¹ The solution of the alcohol question, they consider, lies partly in the control of the liquor traffic, partly in the provision of counter-attractions to the public-house, and partly in the education of the people. They add, however, that the question will never be completely solved until overcrowding and slum areas are abolished.

The views of the authors on certain questions are expressed dogmatically and will not find universal acceptance. We need quote two instances only. An ideal system, they say, by which a vast number of unhappy marriages and diseased children might be prevented would be to require the contracting parties to obtain a certificate of health before matrimony. In the opinion of many of those who have given this question serious attention such a course would merely have the effect of increasing the

number of irregular unions. The second instance is in the chapter upon housing, in which is discussed at some length the present-day problem of providing adequate housing accommodation at a rental which the working man will be able to pay. Except in the case of really bad tenants, the authors consider that the provision of wooden houses will solve to a great extent the present and pressing problems of housing. We should be glad if this optimism could be justified. The greater part of the book shows much care in preparation, but here and there are indications of hurried compilation. This is especially the case in the chapter on local government, in which the county council is spoken of as the local authority which has cast upon it the duty of preventing and abating all sorts of nuisances and insanitary conditions and as being responsible for the prevention of disease. We need hardly say that it is the district council and not the county council upon whom this duty falls. Other instances might be given, but we are sure that the slips will be rectified when a further edition is published, as we feel confident will be the case.

X RAYS IN GENERAL PRACTICE.

General Practice and X Rays, a book written by Dr. ALICE KNOX,³ is intended to be a handbook for the general practitioner and the student. It is divided into two parts: the first, dealing solely with the uses of x rays in diagnosis, will be of use to the busy doctor, since it indicates plainly both by text and illustrations the various conditions in which an x-ray examination is indicated, and in what directions it can be of assistance in any particular case. The author shows very clearly that the radiologist is no mere picture taker, but that in his dealings with another practitioner he is a consultant; as it is important that he should be able correctly to interpret the radiological findings he should be treated by the practitioner in exactly the same manner as other consultants, which essentially means that he should be made acquainted with the history of the case and the existing physical condition of the patient.

The first chapter deals somewhat generally with the sphere of usefulness of x rays in general practice, and discusses amongst other things the preparation of the patient for various examinations, the interpretation of plates, and the dangers attendant on an x-ray examination. The second chapter goes into more detail, and serves to indicate what may be expected in diseases of the chest, alimentary tract, the urinary system, the pelvis, and in injuries and diseases of the joints. The third and fourth chapters, which complete this section, are on the diagnosis and treatment of injuries and diseases in children, and on x-ray treatment generally.

Part II, by Dr. Robert Knox, is a short but clearly written description of the production of x rays and of instrumentation. It is quite elementary, but should give anyone who knows nothing about the subject a very good idea of the instruments used by radiologists, and the manner in which x rays are produced and applied.

This book has a distinct purpose: written in plain and simple language, and well illustrated with numerous diagrams and radiographs, it should appeal to all busy general practitioners to whom the usual scientific textbook and the textbooks for experts are altogether too full of detail. The author can be congratulated on having produced for the profession generally a small, well written, and admirably illustrated book which deals lucidly with all the more important points in radiography and radiotherapy, and which can be easily assimilated by the non-expert. It is a book which every general practitioner who has no special knowledge of x rays will find of the greatest use to him in the practice of his profession.

WOMEN AS ARMY SURGEONS.

UNDER the title *Women as Army Surgeons*⁴ Dr. FLORA MURRAY has written the history of one of the organizations established by medical women during the war. She relates the history of the Women's Hospital Corps in

² *General Practice and X Rays*. A Handbook for the General Practitioner and Student. By Alice Vance Knox, M.B., B.Ch., 1921. London: A. and C. Black, Ltd. (Crown 8vo, pp. 228; 32 plates, 56 figs. 15s. net.)

³ *Women as Army Surgeons*. By Flora Murray, C.B.E., M.D., D.P.H. London: Hodder and Stoughton, 1920. (12p. 265; 23 illustrations. 12s. 6d.)

⁴ *The Principles of Preventive Medicine*. By R. Tanner Hewlett, M.D., F.R.C.P., D.P.H., and A. T. Nankivell, M.D., D.P.H. London: J. and A. Churchill, 1920. (Demy 8vo, pp. 544; 5 diagrams. 21s. net.)

Paris, Wimereux, and Endell Street, from September, 1914, to October, 1919. The record is divided into two parts, dealing respectively with the work in France from September 14th, 1914, to February 17th, 1915, and the long period of more than four years' activity at Endell Street. Early in August, 1914, Dr. Flora Murray, Dr. Louisa Garrett Anderson, and some of their friends, being determined that medical women anxious to give their services to the nation should not be excluded from military work and from the great attendant professional opportunities, energetically collected funds and organized a hospital unit which was established under the French Red Cross in the Hôtel Claridge, Paris, by the middle of September. With Dr. Flora Murray as the Administrator or *médecin-en-chef* and Dr. L. Garrett Anderson as surgeon-in-chief there was little delay in adapting this recently built hotel into a well organized hospital. The story of their experiences, and incidentally of their convincing all and sundry (including both their French hosts and inspecting officers from the R.A.M.C.) that women surgeons could make good, is told with humour and not entirely without digs at the mere men who were "unconverted to women doctors." The foreign language naturally presented some difficulties; left alone on duty a surgeon directed a nurse with the reputation as a linguist to find out if a French officer, shot through the body, had any abdominal pain, the prompt question, "Avez-vous du pain dans l'estomac?" elicited an indignant reply that he had taken nothing but the fluid diet prescribed.

In November an additional hospital at Wimereux was organized with the same high courage and spirit, but early in 1915 Sir Alfred Keogh complimented the Women's Hospital Corps on their work and transferred their activities to London and to the charge of a hospital of over 500 beds. The old workhouse of St. Giles, Bloomsbury, at the upper end of Endell Street, was renovated and transformed into a hospital and the staff got together. Miss Elizabeth Robins and Miss Beatrice Harraden joined as librarians, and the latter contributes the preface to the volume, in which there is a sincere appreciation of Dr. Flora Murray, followed by the comment:

"It is not to be wondered at that the success of this military hospital, officered, staffed and run entirely by women, became a source of immense satisfaction and pride to all women, but more especially to those who had taken an active part in the struggle for the Suffrage, and had shared with Dr. Flora Murray and Dr. Garrett Anderson the ups and downs, the hopes and fears, the disappointments, disillusionments, and encouragements, and all the stress and strain of a long-drawn-out political campaign."

The chapter entitled "The position of women under the War Office," contains the story of the unsuccessful struggle to obtain for women doctors serving with H.M. Forces the same rank as men in a similar position.

NOTES ON BOOKS.

THE *Minutes of the General Medical Council*,⁵ and of its Committees and Branch Councils for 1920, have been issued. The proceedings of the Council have been reported from time to time in our columns. The bulk of the volume is occupied by the Minutes of the Executive Committee, which fill 121 pages, and by appendices filling 173 pages, the latter being chiefly reports presented by the various committees; the minutes of the Branch Councils occupy 17 pages. The *General Index to the Minutes*⁶ has been brought up to date, and includes Vols. xl to lviii inclusive 1903-1920).

The Early Embryology of the Chick, by B. M. PATTEN,⁷ is designed to assist those who are beginning the study of vertebrate embryology. The author's aim is to describe in a clear and simple form the course of development from fertilization until the end of the fourth day of incubation, so that the student may master the facts easily for himself and so "conserve the time of the instructor for interpretation of the broader principles of embryology." In his account of the early development from fertilization until the time of laying, the author has deliberately avoided controversy, and has given a straightforward, but necessarily somewhat artificial, account of the processes as they

are at present known to occur. The comparison of the gastrulation of the bird with that of the Anamnia will carry conviction only to those who do not realize that the diagrams are the only evidence that is put forward. The author has sacrificed too much for the sake of a clear account. He is asking the student to found his beliefs on something other than actual observation. To the rest of the work great praise is due. The accounts of the various processes of development are clearly explained. The figures are good (there are 182 of them) and the method of direct labelling undoubtedly makes them easy for the student to follow in reading the book. It is like having Duvall's Atlas with a clear account of the various stages written alongside. No directions for practical work are given, a wise omission, as they would have increased the size of the work without increasing its value. There is an excellent select bibliography at the end of the book.

BRITISH CHEMICAL INDUSTRIES.

On February 19th a number of British firms engaged in the production of fine chemicals issued a circular letter pointing out the national importance of the industry, and stating that in the years following 1914 they had, at the urgent appeal of the State, extended their research and manufacturing plant in order to secure those essential products of science without which victory could not be attained. The letter went on to state that this key industry is now in danger, owing to the flood of imports from abroad, which the present condition of the exchanges, among other circumstances, makes possible.

We have since received from a number of old-established British firms more particularly concerned with the production of drugs an appeal to medical men of the British Empire to support British industry. The signatories disclaim any political object, desiring merely to lay the following facts before the profession:

"(1) In all fairness, it should be realized that international trading is not on a reciprocal basis, that is to say, foreign chemicals and pharmaceutical preparations are admitted into this country, practically speaking, duty-free, whilst goods exported from this country to countries abroad are subject to an exceedingly high *ad valorem* duty. One vast country we have in mind directly prohibits the import of pharmaceutical preparations of other countries, while other immense states do so indirectly by means of the high duty already referred to.

"(2) It should be remembered that although much has been done during the war and since in the direction of promulgating British chemical industry, a great amount of work has yet to be done to consolidate the fine chemical and allied industries at home, and an obvious point is that the factories in Germany are for the most part absolutely intact, and she retains secrets which are the outcome of laborious, painstaking investigation.

"(3) We desire respectfully to impress on your readers that we do not advertise to the public, nor 'prescribe,' nor in any way trespass on the rightful province of the medical practitioner; on the contrary, we rely on the position that the chemist, so far as the medical use of chemicals is concerned, is the handmaid of the medical man, and we might add, rather bluntly, we do not recommend foreign medical men and health resorts. Why should the medical man recommend foreign pharmaceutical preparations?"

"(4) The scientific staffs in our laboratories welcome suggestions from medical men, and will carry out investigations to elucidate problems connected with chemistry, materia medica and the like, which may prove of assistance in the art of healing.

"(5) We have in our employment men who have been through the hell of the recent war. We have also with us young pupils and apprentices who have never even heard the name of Lister, and who know nothing of his teaching until we have taught them what he did for suffering humanity. These two types of men, in our opinion, need every support, encouragement and protection which the medical man can give."

The appeal ends as follows:

"We ask the doctor to demand British produce, and furthermore convince himself that what is stated to be British is British, and by so doing enable us to give employment to more and yet more British workmen, and to compete with foreign enterprise on the unequal footing above mentioned."

THE title of the Spanish periodical *Revista de Medicina y Cirugía Prácticas* has been changed to *Archivos de Medicina Cirugía y Especialidades*.

DR. ALEXANDER FRAENKEL has resigned the editorship of the *Wiener klinische Wochenschrift*, which he has held for twenty-five years.

AN institute of medical bibliography has been established at Naples. Its organ is to be a monthly journal entitled *Notiziario della stampa medica*.

⁵ London: Constable and Co. 12s.

⁶ London: Constable and Co. 7s. 6d.

⁷ *The Early Embryology of the Chick*. By B. M. Patten. Philadelphia: P. Blakiston's Son and Co. 1920. (Roy. 8vo, pp. 167, 55 illustrations.)

THE EPIDEMIOLOGY OF INFLUENZA.

With the exception of a chapter on the clinical aspects, to which reference is made elsewhere, the first part of the Ministry of Health's Report on the Pandemic of Influenza¹ is devoted to the epidemiological study of influenza. The modern history of the disease is first recounted, then the statistics of 1918-19 are examined, next the clinical and the bacteriological features are described. In the four following chapters particular problems—namely, the extent of protection conferred by previous attack, the relation between meteorological variations and epidemic influenza, the epidemiological significance of domestic overcrowding, and the special prophylaxis of the disease—are considered. In the last chapter an attempt is made to summarize the lessons to be learned.

HISTORY.

The historical chapter does not profess to be exhaustive, but examines in some detail the sequence of events from the time of Sydenham. The writers point out the difficulty, amounting to impossibility, of providing a logically complete definition of "influenza," but remark that "if into the definition of influenza, while maintaining the characteristics of *apparent* suddenness, undoubted rapidity of evolution, and usually low fatality, we import the conception of peculiar attendant circumstances, such, for instance, as a break in the uniformity of epidemiological history prior to the outburst, and also keep in mind the catarrhal element of the explosive disease as a frequent clinical experience, we shall reach a plan of identification which is not logically assailable." Following this clue, it is shown that both in the experience of Sydenham and in that of his greatest successor as a medical analyst, Huxham, epidemic influenzas were dramatic incidents occurring in series of years characterized by less striking but yet distinct abnormalities of the public health.

"We think," say the compilers, "Huxham's narrative establishes the proposition that the epidemiological features of the cycle of years within which influenza exploded once or more were, *apart from such explosion*, different from the characteristics of the influenza-free epochs. Huxham's crowded references to intermittents around the explosive manifestation of influenza in 1743, his silence between 1745 and 1752, the paucity of his remarks on the subject during the quiet years 1759-42, are paralleled in the story told by Sydenham. We are also justified in making a comparison between the strange nervous fevers incidental to Huxham's narrative and Sydenham's new fever of 1685. With these long-sustained chronologies by skilful observers to guide us, it is not fantastic to suppose that the inter-relation of 'agues' and influenzas to which Dr. Creighton called attention in the section of his history dealing with the sixteenth and seventeenth centuries, is more than casual and not a mere reflection of some theoretical pathology."

It is shown that similar but less complete evidence exists respecting the influenzas of 1762 and 1782, but that no adequate chronologies of the pandemics of 1803 and of 1831-37 have survived. Both for 1847 and for 1918, there is evidence of an abnormal condition of the public health apart from influenza, but the same remark hardly applies to the years which ushered in the great epidemics of the last ten years of the nineteenth century. Still, even for this latter period—which, as the authors candidly emphasize, constitutes the most formidable objection to the view that influenza is not an isolated event but an incident in a series of related events—prior to the supposed importation of influenza very remarkable localized outbreaks of disease had occurred, such as that at Northallerton in 1887 and the fatal epidemic of pneumonia in Middlesbrough more than a year before the pandemic. The general conclusions drawn by the compilers are in essential agreement with those reached by Dr. Hamer and by Dr. Crookshank; they doubt whether the ravages of influenza can be stayed by the discovery and destruction of some remote endemic focus of the disease, and hold that

"The problem of epidemic influenza is largely an internal problem of each nation; there is no question of shutting the wolf out of the sheepfold, he has been regularly lying down with the lamb for years; his ravages depend as much upon the disposition of the sheep within the fold as upon his appetite. Thus broadly stated, the hypothesis neglects some portion of the truth; however combustible the material, there can be no fire without a spark, and when the fire has been started it may spread to material not naturally combustible. We must not ignore this consideration, but it has perhaps been over-emphasized in current discussion."

RECENT STATISTICS.

In the following chapter the general statistics of 1918-19 are examined. It is pointed out that: "(1) The mortality in England and Wales, as a whole, attributable directly or indirectly to influenza, is without any precedent in magnitude; (2) that that of the metropolis affords a parallel more recent than 1847; (3) that the toll taken at the young adult ages of life is without any known West European or North American precedent." The relation between the death rates from influenza in the three waves and the normal pre-epidemic standardized rates (all causes) of the county and metropolitan boroughs is studied by the method of correlation. It is shown that the death rates in the first wave were substantially correlated with the normal death rates, a finding comparable with that of Professor Raymond Pearl of Baltimore, who showed that in America "an essential factor in determining the degree of explosiveness of the outbreak of epidemic influenza in a particular city were the normal mortality conditions prevailing in that city"; but, for reasons explained in the report, the compilers do not regard their arithmetical results as deserving of much confidence, and suspect that the heterogeneity of the data has influenced the numerical magnitudes of the correlations. The writers devote attention to the form of the epidemic wave in time. They remark that the data of epidemics on ships, carefully compiled by the health authorities of the Commonwealth of Australia, are particularly instructive, that the forms of these curves are complex, almost suggesting in each a triple wave reproducing in miniature the world evolution of the pandemic.

"On the ship we do really have ordinary social life in isolation from the great world, a real microcosm. The remarkable point is that within this microcosm we have seen in miniature a triple wave, such as the whole world experienced, but running through its phases in weeks instead of months. But this evolution was not parallel with the world evolution, since the voyage started after the first act of the world drama. Whatever organism was 'carried,' it must have belonged to the autumn variety, not to the summer vintage. Hence, if this threefold wave phenomenon is not a mere illusion, it would seem to be a function of the organism as modified by passage, a modification determined by the environmental conditions."

BACTERIOLOGY.

The chapter on bacteriology, by Sir Frederick Andrewes, is worthy of its author's reputation. At the outset Sir Frederick warns the reader that "the germ theory of disease is now so firmly established that we are in danger of too readily accepting a microbe as the causal agent of a disease, and of neglecting the rigid proofs which should be demanded." He points out that from the experience gained between 1890 and 1918, "it cannot be said that the status of Pfeiffer's bacillus as the cause of epidemic influenza had materially altered. No further confirmation had been obtained, nor had the observed facts disproved a possible relationship." The results in 1918 did not suffice to settle the question. The failures to recover Pfeiffer's bacillus in the summer could not, in Sir Frederick's opinion, be referred to a faulty choice of medium or defective technique.

"Amongst those who have recorded their failure to find the organism are bacteriologists of the highest repute: the failures were perhaps more numerous in Germany than elsewhere: such men as Kolle, Gruber, Friedemann, and many others, failed to find it, while Uhlenhuth and Pfeiffer himself were puzzled at their want of regularity in finding it. It is expressly stated by Sobernheim that, using precisely the same technique, he uniformly failed to find it in the summer epidemic and almost uniformly succeeded in October." "The evidence," says Sir Frederick, "does not carry conviction as to the primary causal relationship of Pfeiffer's bacillus to epidemic influenza. The varying results cannot be correlated with the competence of the observers. The observed facts, notably the earlier negative findings in certain localities, and the more general positive results in the autumn outbreak, would be better explained on the assumption that the bacillus played a very important secondary rôle in the disease, and was not the primary infecting agent." Decisive significance cannot be assigned to the results of agglutination or complement fixation tests because Pfeiffer's organism is at least so commonly present as a definitely pathogenic invader "that it would be strange indeed if antibodies were not formed against it."

Important evidence might be furnished by unequivocally successful results of prophylactic immunization by vaccines containing Pfeiffer's bacillus. Sir Frederick Andrewes calls attention to the apparently striking results of large scale inoculations, but notes the desirability of

¹H.M. Stationery Office, (10s. net.)

statistical criticism. This point is in fact taken up elsewhere in the report, where it is remarked that "no inferences can be drawn from a lower attack rate upon inoculated than upon uninoculated persons if the inoculations were carried out during the epidemic, without due allowance for variations of length of exposure." This simple consideration rules out most of the published data. For the rest, the compilers say:

"Such evidence as we have in favour of any practical advantage points to the efficacy of vaccines derived from organisms cultivated from cases existing in the neighbourhood of the tested population. This is illustrated by the example quoted in the section on influenza in the annual report of the Chief Medical Officer. A pure Pfeiffer vaccine was used for the inoculation of employees (volunteers) in a London business house, and the inoculated escaped the disease, while their co-workers experienced a normal incidence. It appears doubtful whether any simple stock vaccine derived from a limited number of strains of micro-organisms implicated in the clinical evolution of influenza is likely to be of value."

It cannot be said that the evidence derived from prophylactic inoculation much strengthens the case against Pfeiffer's organism as the primary pathogenic agent.

Sir Frederick Andrewes thinks that the evidence in favour of a filter-passing organism as the essential cause is suggestive but unconvincing.

"The strength of the case argued by Gibson and his colleagues lies in the fact that there was a definite incubation period in their experiments, that they succeeded in carrying on the effects through more than one generation of animals, and that they produced them with cultures. The weakness lies in the fact that the lesions in their animals do not afford convincing proof of influenza. . . . The cultivation of filter-passing organisms is notoriously a difficult thing, and beset with many fallacies, as Arkwright has well pointed out in his recent criticism of the subject. The results so far recorded in influenza must be received with caution."

Whether or not a primary significance can be assigned to Pfeiffer's bacillus, Sir Frederick believes "there can be no doubt that it played a part of vast importance in the recent epidemic of influenza. Though we know it, at normal times, as a mere agent of catarrh, the more virulent types which prevail in epidemic times are more highly toxic, and seem especially to lead to escape of blood from the smaller vessels in the lungs and bronchi. It seems probable that we must regard Pfeiffer's bacillus as the chief cause of the haemorrhagic oedema and the localized haemorrhagic areas in the lungs which have been so conspicuous a feature of the late epidemic." Next in importance come certain types of streptococci; *Streptococcus haemolyticus* has been often found in the pulmonary lesions, and its presence there has "been a distinguishing feature of the epidemic, especially in the autumn, when the disease exhibited its highest fatality, and it was found in the worst cases."

IS IMMUNITY CONFERRED BY A PREVIOUS ATTACK?

In the next chapter the compilers discuss the question whether those who had been attacked by influenza in one phase of the pandemic were, on that account, less liable to attack in a subsequent outbreak. This matter is examined in detail and perhaps constitutes the most original section of the report. Briefly, the method adopted was this. The histories of considerable samples of different populations were followed through all the phases of the epidemic, and it was determined whether the attack rates in, say, the autumn were significantly different (from the statistical point of view) upon those who had and those who had not been attacked in the summer. It was found that the after-histories of the exposed to risk were very different in different places. In some cases—for instance, in Leicester—those attacked in the summer came off far better in the autumn than those who had not been attacked in the summer; in other cases—for instance, in Manchester—the summer victims experienced an identical rate with that suffered by those not attacked in the summer. The possible reasons for these differences are discussed in detail, and the conclusion is reached that the immunizing value of the strains of organisms probably differed in different parts of the country. The method of analysis is subject to a theoretical criticism. Thus it is assumed that if the attack rates in the autumn upon those who were and were not attacked in the summer are the same, then the summer attack conferred no protection. But if those singled out for attack by the disease in the

summer were so singled out because their resisting power was low, then, *ceteris paribus*, they should again have a higher attack rate in the autumn; if they have only an equal attack rate, the summer experience helped them. But it may be urged in reply that there is little or no evidence that the first phase of the pandemic did select those who, judged by any extrinsic criterion, were peculiarly liable to respiratory attacks. In any event, the practical result that whatever protection was conferred was far from being absolute, is plain. Upon the whole, there is a balance of probability that the summer influenza had some immunizing value; less reason can be shown for thinking that autumn attacks shielded their victims in the third phase.

THE WEATHER.

The following chapter deals with the weather and disease. This chapter contains an interesting summary of traditional opinions and brings out the relation between changes of temperature and variations of mortality from respiratory disease. It also shows that before each of the three waves of influenza warmth was deficient, but, as might have been expected, the compilers hold that whatever part was played by meteorological factors in the genesis of the pandemic must have been quite a minor one.

OVERCROWDING.

In the next chapter the relation between domestic overcrowding and the incidence of influenza is studied; no close statistical relation was found and the tentative conclusion is reached

"that the natural infectivity of the germ may be so high that the necessary exposures and contacts of all persons living under urban conditions are sufficiently numerous to provide opportunities of transfer so effective that any increase above the average is relatively a factor of negligible order."

It is, however, specifically stated that these conclusions apply solely to incidence, not to fatality, it being probable that the fatality amongst patients grossly overcrowded (as, for instance, upon war transports) was far above the average.

Chapter IX deals with general prophylaxis. The compilers remark that

"from what has been said in this report it follows that to avoid crowds, to shield the mouth and nose when coughing or sneezing, not wantonly to thrust one's face into the face of one's interlocutor, are essentially rational and appropriate methods of reducing the risk to take influenza. It even appears probable that the one form of overcrowding which in some little measure can be controlled by the individual is the form most potent to spread the disease. In the present state of the nation, to advise the avoidance of overcrowded tenements and lodgings is indeed a counsel of perfection; it is likewise a vain quest to seek for public conveyances not grossly overcrowded; but it is quite easy not to frequent theatres, music halls, and picture houses; it is even possible to avoid bargain sales, political meetings, and assemblies. These forms of congestion belong to the extra-domestic group which, by a process of exclusion, we have discovered to be more influential than intradomestic conditions admittedly hard to control now."

Much importance is attached to the hygiene of the nasopharynx, and attention is directed to the researches of Dr. Leonard Hill (described in his reports to the Medical Research Council, and also in our columns). Due weight is given to the importance of further research into the immediate etiology of the disease, but "the public should not suppose either that nothing of service can be attempted until the authentic *materies morbi* of influenza has been unequivocally defined or that the recognition and successful isolation of the authentic microbe would necessarily be followed by elimination of the influenza scourge."

SUMMARY AND FINAL HYPOTHESIS.

The last chapter of this part is a general summary of those we have discussed, and a provisional statement of a hypothesis which covers the facts. This hypothesis is that there have been three phases in the development of influenza.

"The first, which has led for many centuries, was, if we may be permitted to use teleological language, a series of attempts to maintain a high level of infectivity or dispersiveness, which attempts were unsuccessful. The second phase, ushered in by the year 1889, is marked by a partial victory of the germ, a fairly constant infective power has been secured, and much infection is produced throughout the world at frequent intervals, but the toxicity relative to the infectivity is still slight. The final phase is of complete victory; infective power is augmented, even enhanced, and to this is added a toxicity surpassed

by few epidemiological competitors. Viewed as a contest between man and 'germ,' it would seem that in the congestion of public transport and the multiplication of public assemblies and entertainments, features which increasingly characterize the development of the European type of civilization, a strategical advantage was given to the enemy. Finally, in the provision of countless incubators, whether in garrisons, wartime factories, or abnormally overcrowded and ill-ventilated means of transport and places of entertainment, the opportunity was afforded for the development of destructive powers which secured to the enemy a decisive and overwhelming victory."

These reflections suggest that there are dangers ahead.

"The dangers to the world from epidemic sickness in this matter of influenza are enhanced in two ways. The inevitable trend of the movement of population will keep the infectivity of the organism at a high level. This we may face with equanimity. But if anywhere in the world there be large collections of men, whether through war or economic strife, or through that dissolution of society which a certain degree of collective misery and disorganization entails, herded together *en masse*, there will be opportunities for the other modification of the *materies morbi*, which renders it apt to conquer the world. No sanitary cordon, no quarantine, will shield us from this danger. The porters of the infection may not be sick; to exclude even the sick has often been found a task beyond the power of a quarantine authority; and quarantine has, in fact, never yet succeeded. To realize that the material well-being of the inhabitants of a foreign—perhaps even a hostile—country is a pressing concern of ours is very hard. Yet the teaching of this pandemic is that it is a hard truth. Any supra-national organization for the control of epidemics will need to face it. The popular belief that misery breeds disease is strictly true, and the influenza of 1918-19 is no exception to the rule. The history of the world has never yet provided an instance of a mortal and highly dispersive illness among the antecedents of which human misery did not assume a prominent place."

In his introduction to the volume Sir George Newman emphasizes one aspect of this doctrine—namely, that, as he puts it,

"The fundamental requirement to make us masters of our fate is a universal improvement in the standard of health and the conditions of life. No technical device, no narrow or specific remedy for pestilence, can ultimately triumph apart from a sanitary environment for the community and the sound nutrition of the individual. They are the bed-rock. Out of them spring the sources of national vitality. Hardly less certain is it that we require, and must seek till we find, more knowledge. We have in substantial degree the means of controlling tuberculosis and syphilis, malaria and plague; we fail to control these four pestilences largely because we do not use the means; and education is perhaps the answer to that. But in the case of influenza and its allies we are not yet in possession of the means, and whilst we press forward with the improvement of sanitation, of nutrition, and of the conditions of life, we must apply ourselves anew to search and research into the causes of primary and secondary infections, into epidemic catarrh, and the common cold, into carriers, and into immunity. That is perhaps the principal lesson which is taught us by our experience of the great pandemic."

With this quotation from the preface by the Chief Medical Officer we shall conclude our notice of the report. The second part, compiled by Dr. Bruce Low, C.B., and Dr. S. P. James, which compresses within less than 200 pages a vast amount of statistical and other information respecting influenza abroad, does not lend itself to summarization, but is not the less worthy of perusal. The same remark applies to the valuable collection of scientific papers by medical officers of health, as well as by officers of the Ministry, which form appendices to the report.

We believe that Sir George Newman was justified in characterizing this report as a "contribution of exceptional interest and suggestiveness," and that its authors, both the medical members of the Ministry's staff and the other medical men, not civil servants, who have collaborated, deserve the thanks of their colleagues. A volume of 577 pages which announces no sensational discovery and promises no conquest of influenza in the near future cannot render its authors popular heroes. They will, however, be sufficiently rewarded if the outcome of their labours is of use to other students of a menacing yet fascinating problem.

THE Hispano-Portuguese Association for the Advancement of Science will meet at Oporto in June.

A SCIENTIFIC expedition to Central Asia, under the direction of Dr. Roy C. Andrews, has been organized in the United States by the American Museum of Natural History to carry out researches in anthropology, archaeology, zoology, and medical geography in the less explored regions of Turkestan, Tibet, and Mongolia.

UNIVERSITY GRANTS.

THE University Grants Committee appointed in July, 1919, to inquire into the financial needs of university education in the United Kingdom, and to advise the Government as to the application of any grants that may be made by Parliament towards meeting them, has made a report,¹ after giving full consideration to all the representations made to it, and after carrying out a series of visitations to all the universities and colleges in England, Scotland and Wales. The parliamentary grant is now £1,000,000 a year; in 1919-20 a special grant of £500,000 in addition was made, and in 1920-21 the unexpended balance of this, amounting to £196,000, was available. During the past year nearly the whole of this unexpended balance has been distributed. The Chancellor of the Exchequer has promised that the annual vote this year shall be increased to £1,500,000.

The medical member of the University Grants Committee is Sir Wilmot Herringham, who succeeded the late Sir William Osler in November, 1919.

The Committee begins by expressing its sense of the efficiency maintained in the universities and colleges generally in face of many and serious difficulties, but is convinced that the present resources of the universities are inadequate, in spite of the facts that since the armistice the Treasury grants have been increased by 83 per cent., that tuition fees have been increased, that a few local education authorities have increased their support, and that many of the universities are endeavouring also to supplement their revenues by public appeals. On the other hand, it is pointed out that all expenditure, in particular unavoidable expenditure on wages and material, has grown enormously, and that even if the pre-war income were doubled, it is doubtful whether the universities would be as well off as they were before the war.

The report goes on to point out that the number of students since the armistice has been unprecedented; the total number of full-time students in attendance at grant-aided institutions and colleges rose from 23,872 in the academic session 1913-14 to 36,423 in 1919-20, and the number was raised to 37,748 by the addition of certain colleges to the list. Of this total 11,682 were ex-service students, but it is pointed out that a permanent increase over 1913-14 is to be expected, owing to the larger number of secondary schools and to the operation of the Education Act, 1918.

An important part of the present financial embarrassments of the universities and colleges arises out of the need for increased salaries and improved superannuation. The Committee agrees that the present salaries of many university teachers are inadequate, and has evidence that many members of the university staffs are living in circumstances incompatible with continued efficiency; many teachers are not in a position to enjoy the advantages essential to the proper discharge of their duties, such as books, travel and membership of learned societies. Further, many are compelled to supplement their income by dissipating their energies in outside work. The Committee does not commend the scheme of salaries and increases proposed by the Association of University Teachers; it agrees that it would be an advantage if all the grant-aided institutions agreed upon minimum salaries, but does not agree to a dead level of uniformity as between institutions. The Committee also agrees that it is important to establish an equitable system of superannuation. The Federated Superannuation System for the Universities in England, established in 1912, provided that 5 per cent. should be paid by the institution and 5 per cent. by the beneficiary. The contribution of the institution has now been increased to 10 per cent. The youth of the scheme renders it desirable to make special provision for many of the senior teachers. The position in Scotland is special, and is, the Committee thinks, unsatisfactory.

An important section of the report deals with equipment and accommodation, and it is declared that the character and efficiency of a university may be gauged by its treatment of its central organ—the library—which is essential to the well-being alike of the arts and science. Ampler funds are needed and the status of the librarian should be improved. For the subjects included in the faculty of pure science additional staff and improved accommodation and equipment are required. In the

¹ Cd. 1163. H.M. Stationery Office. Price 3s. net.

majority of the institutions visited extensions of the chemistry or physics laboratories are either contemplated or in progress, and the needs of the departments of geology, botany and zoology are realized to be hardly less acute.

In dealing with the applied subjects it is admitted that it is not possible to draw a hard and fast line between pure theory and practical application, and in vocational training it is essential to maintain that breadth and proportion of view which are implied by a university standpoint. The bases on which applied science is founded are ever broadening, and as an illustration of the doctrine that university courses must tend to become increasingly exacting if they are to be continually informed with fundamental principles, the following remarks are made about the Faculty of Medicine:

Medicine.

"The Faculty of Medicine is, perhaps, the best example of the combination of the theoretical and practical, the liberal and the vocational, to which we have just referred, and the thorough grounding which it requires in the basic sciences, physics, chemistry and biology, and in the intermediate, anatomy and physiology, illustrates what we believe to be an essential condition of a university education in any applied science.

"It is held by some that the basic sciences should be studied at school before registration, and we are so far in accord with this view that we think that no education can be called liberal which leaves a student at eighteen ignorant of the fundamental laws of Nature upon which rest also the processes of the arts. But there are at present too few secondary schools in which these subjects are properly taught to allow the universities to dispense with suitable courses for medical students, and also there are special parts of them which are necessary for their application in anatomy and physiology, but are not included in the usual school courses anywhere. The universities, therefore, have not only been compelled to continue to teach these sciences to students of medicine, but have in the last twenty-five years greatly extended and improved the teaching that they provide. Almost within the same time pathology, which in former years was largely confined to morbid anatomy, has expanded so far as to include the vast fields of bacteriology with immunity, and of morbid metabolism, or chemical pathology. It even seems probable that pathology will soon require a physical department, for certain pathological conditions are connected with changes in the blood and other tissues which are essentially physical in character and need physical methods for their evaluation. The whole group of these sciences has passed or is passing into the hands of teachers who devote themselves entirely to the work, and each subject is taught in laboratories which occupy a large amount of space, and are extremely expensive to equip and to maintain.

"The Royal Commission on University Education in London reported in 1913 that the teaching of the final medical subjects in England, though in its practical training of students probably the best in the world, was in some ways deficient in the scientific aspects of the subject. They remarked, and it is generally allowed, that to obtain the best teaching it is essential that the clinical teacher should be himself engaged in the discovery of fresh truths, and should be at the growing point of knowledge. So far as clinical methods can reach, English teachers have no cause to reproach themselves on this score. Accurate observation, which is the foundation of all discovery, has been practised and taught by clinicians in England as thoroughly as anywhere in the world, and up to the present day England has in this field been fully abreast of other nations. But since the middle of the last century, experiment, on the necessity of which Harvey himself insisted, has been applied to medical problems with such increasing vigour and success that the laboratories have become almost as important as the wards. On this side England has been wanting. There has been much brilliant experiment, and much discovery, for instance in diseases of the nervous system, and in metabolism, and in the application of bacteriology, but it has been the work of private individuals who for lack of means have not been sufficiently helped, and often have not even been encouraged, by the schools. It has not been considered a necessary qualification for teaching medicine that a man should have practised this method of advancing it.

"The Royal Commission recommended that to remedy this defect a professorial system should be set up which would provide teachers and an assistant staff willing and

able to devote themselves to scientific investigation. At the instigation, and with the assistance of the Board of Education, whom we have succeeded in the task, this system has been put into operation in certain medical schools in London under the name of "Clinical Units." At such schools directors have been appointed who, entirely or almost entirely resigning private practice, give themselves up to hospital work, treatment of patients, the teaching of students, and the clinical and experimental study of disease. An adequate staff and laboratories have been or are in process of being supplied. Medical and surgical units have now been established, with the assistance of grant-aid from the Treasury, at the medical schools attached to St. Bartholomew's Hospital, the London Hospital, University College Hospital, and St. Thomas's Hospital. At Edinburgh and Sheffield new professorships have been created on a similar basis, and our tour of inspection has shown us that everywhere throughout England and Scotland the principle has been seized, the need realized, and, where circumstances did not admit of such new appointments, great efforts were being made by the present staff to render the teaching more ample and more vivid. The Committee have issued a statement for the guidance of the university bodies contemplating the establishment of new arrangements to this end."

The report contains many references to the importance of maintaining the self-governing powers of the universities. In a concluding paragraph the relation of this principle to finance is brought out. The official grant-in-aid provided since the armistice and the further increase promised or contemplated by the Chancellor of the Exchequer prove that the Government and Parliament are not unmindful of their responsibilities, and the expectation is expressed that the claim of higher education upon private generosity will be similarly appreciated. The Committee goes on to emphasize Mr. Chamberlain's reference to local support as a principal factor in future grant allocations, and urges university authorities to regard their endowment funds as the central source of their revenue, "for it is in our view indisputable that only by the consolidation of a stable and substantial income from independent sources can the autonomy and progressive development of a university be assured."

DISEASES OF ANIMALS COMMUNICABLE TO MAN.

PROFESSOR HOBDDAY, C.M.G., who holds the chair of therapeutics and hygiene in the Royal Veterinary College, London, gave an address on "Some of the diseases of animals communicable to man" at a combined meeting of the Royal Society of Medicine and the Central Branch of the National Veterinary Association on February 3rd. Professor Hobdday began by observing that the study of comparative medicine would throw much light on the symptomatology of disease and on immunity and susceptibility, certain species of animals being refractory or even completely immune to certain diseases. He then went on to point out that the list of diseases communicable from animals to man which exist at the present time in Great Britain comprises at least the following: Glanders, anthrax, tuberculosis, rabies, foot-and-mouth disease, mange of all animals (the horse, ox, camel, dog, cat), ringworm (especially of the horse, calf, cat, and mouse), and certain forms of seborrhoea (such as farriers contract from handling horses with greasy legs). The great prevalence of pyorrhoea in pet dogs, which are so kissed by their fair owners and allowed to lick their lips and hands, should be regarded as a possible factor in the spread of that disease in human beings. Certain parasites require an animal host in order to make their life-cycle complete before they can become pathogenic to man, such as the echinococcus, the *Cysticercus bovis* (the larval stage of the *Taenia saginata* of man), and *Cysticercus cellulosae* (the larval stage of *Taenia solium*), the parasites of mearly beef and mearly pork respectively; and the *Trichina spiralis* of the muscles of the pig, which give rise to trichinosis in man in countries where ham is largely eaten smoked, and not necessarily cooked.

Glanders.

Were glanders eliminated from the veterinary schedule, said Professor Hobdday, it would disappear as a disease of mankind. In this matter the veterinary profession has to lead the way: that it is doing so is shown by the fact that in 1901 some 2,370 horses (1,828 from London) were destroyed for glanders in Great Britain, whereas during

1920 only fifteen outbreaks occurred in the whole of the British Isles, and only 22 animals were destroyed, and this after the sale of some 150,000 army horses and mules which had been collected from various countries and employed in the work of the great war.

Mallein is a sure diagnostic test and an important agent in the eradication of this disease. By its aid glanders was completely kept under control among the thousands of British horses and mules during the late war in Europe, and I believe that no case of glanders in man was reported; during the South African campaign glanders was terribly rife amongst animals and caused endless anxiety both to veterinary and medical officers.

Some fifteen or twenty years ago, in the districts of London which contained large cab and omnibus stables, it was rare for a County Council veterinary inspector to pass a day without being called in to see a suspected case of glanders, and I recollect one stud of about 2,000 horses from which we got some 90 glandered horses within twelve months. Mallein was then on its trial, and the law did not enforce its compulsory use in in-contact cases, the consequence being that when the owner of the stable had an outbreak of glanders he promptly sent the in-contact animals to a repository, and thus disseminated the disease broadcast. Twice I have officially been present at the *post-mortem* examination of men who had died of the disease, and in neither case was the disease suspected until just before death; one patient was treated for pleurisy and the other for rheumatism.

At the present time mallein is compulsorily applied by law to all ponies before they are sent underground for colliery work, and when an outbreak takes place in any stud or stable in any part of the British Isles the whole of the in-contact animals are immediately quarantined and tested. All animals that react are destroyed, and all suspects are set aside and re-tested, until the veterinary inspector is satisfied that a clean certificate can be given to the stud. During the late war special precautions were taken by the officers of the Royal Army Veterinary Corps to isolate and apply mallein to all animals on purchase, and again on admission to, and evacuation from, veterinary hospitals. Mallein was administered to all units at regular intervals and when finally sold either for work or for human food all were submitted to this test. In this way millions of doses were used, but the result justified the trouble taken, and no army of the whole allied force was so free from glanders as ours.

The infection is usually transmitted to man from a glandered horse, ass, or mule, by the discharge from the nose or a farcy bud, or by contact of an abraded surface with a sponge or brush, or other stable utensil, which has become contaminated with some of the infectious discharge from the animal. The possibility of infection of man by ingestion was emphasized by the late Mr. Hunting, Chief Veterinary Inspector of the London County Council, who observed men handling the nostrils of infected horses, and then eating their bread and meat, or bread and cheese, without washing their hands. The men most commonly affected are those whose life brings them into contact with horses. I believe I am correct in stating that there is only one instance on record in which a human patient has survived and permanently become clear of a glanders infection—the fortunate man being a well known member of my own profession; but it was only after endless operations and several years of painful treatment. One of those who died of this disease last year was a veterinary bacteriologist of the Government of India, a man of great promise, the disease being contracted during his course of duty. Among carnivorous animals glanders has been observed in lions fed in a zoological garden on infected horse-flesh which was given raw.

Anthrax.

Anthrax still takes its toll of both animal and man, being met with in man principally amongst those who have to deal with animal products, such as skin, hair, wool, and hides from abroad; and those who make, or assist, at *post-mortem* examinations on dead animals. The infected Japanese shaving brushes is another source of danger. The veterinary surgeon sees the disease most commonly in cattle, although it is met with in the horse, sheep, pig, and even the dog; in the dog it is rather more refractory than in other animals. The returns of the Chief Veterinary Officer of the Ministry of Agriculture for 1919 show that Wales had been absolutely free for three years, but that 180 outbreaks were confirmed in England and 59 in Scotland. In all, 275 cattle, 8 horses, 1 sheep, 38 pigs, 1 dog, and 7 ferrets were affected; 25 per cent. of the outbreaks took place on premises where anthrax had occurred during the previous year.

Owing to the precautions taken by the officials of the Ministry, the number of outbreaks has been reduced from

an average of about 1,000 annually between 1907 and 1910 to 239 in 1919. If only the disinfection of imported hides, wool and hair, etc., can be thoroughly controlled, we shall hear of fewer cases in man, and the same may be said in regard to the supply of cottonseed and other cakes imported into Great Britain as a food for cattle. The surmises made as to the source of the outbreak in 1919 were that it was due (1) to the effluent of tanneries or other similar industries getting into streams, (2) to feeding pigs with infected offal, (3) to the use of imported foodstuffs and artificial manures, (4) to contaminated sewage, and (5) to contact with infected material from other outbreaks. It is by attention to the complete disinfection of animal products and the sources of contamination by animal products that we shall diminish the chances of infection to man. For animals themselves it is a more difficult problem as so much of their food material must of necessity come from abroad, and a good deal of it comes from countries in which anthrax exists to a considerable extent.

Rabies.

For nearly twenty years rabies had until lately no place in this country, and the present inconvenience from which dog-owners in several parts of England have to suffer is entirely due to the surreptitious importation of some dog which at the time was in the incubation stage of the disease. All Continental countries, with the exception of Norway, Sweden, and Denmark, are infected. Although mainly seen in the dog, rabies is also met with in the horse, cow, sheep, cat, fox, wolf, and even the fowl; in some of these animals the train of symptoms it produces is rather curious, and may not arouse any suspicion of the disease in the mind of the layman. Everyone knows something about the suspicious signs in the dog, although the classical symptoms are by no means constant. The change of manner, the desire to hide in dark corners, great excitability towards strange people and strange dogs, restlessness and weariness, snapping at imaginary flies, the attempts to chew and futile attempts to swallow all objects near at hand, the inability to swallow water, the continual salivation, and the final violent rage in the mad form—or the typically dropped jaw in the paralytic form—are all characteristic of the rabid dog. It is strange, too, what long distances the dogs will cover in their unconscious frenzy, wandering aimlessly on for miles; and it is for this reason that sometimes a large area or district has to be placed under the restrictions of the Ministry of Agriculture. The voice becomes altered, the bark being hoarse and accompanied by a most peculiar howl, the sound of which, when once heard, is never forgotten. Paralysis of the hind quarters and complete exhaustion and coma finally close the scene if the disease is allowed to terminate the animal's existence.

In the cat the symptoms are even more violent, and a rabid cat is even more to be feared by man than a rabid dog. It will bite and scratch, attacking men and animals in a most reckless fashion. The voice changes in tone, and eventually paralysis of the hind quarters comes. In the horse and ox there is violent excitement, and a particular symptom which has been noted again and again is an attempt to bite or rub the scar of the original site of infection, practically always the bite of a rabid animal. Sexual excitement is often present. Paralysis of the hind quarters is the common sequel, and the disease is always fatal.

The annual report of the Chief Veterinary Officer of the Ministry of Agriculture for 1919 showed that 143 cases of rabies were confirmed in that year (140 dogs, 2 horses and one pig). The first case was imported into Plymouth somewhere about May, 1918, and it is to this piece of criminal thoughtlessness on the part of someone that we owe the fact that we are now again an infected country. During 1919 alone some 179 persons were bitten by animals in the scheduled areas; of these, 46 were bitten by animals proved to be rabid. Treatment was arranged by the medical officer of the Ministry of Health, and it is a triumph to the memory of Pasteur that there have been no deaths from hydrophobia.

By the present arrangements the neck and head of any dog which has died or been killed as a rabies suspect is dispatched at once to the veterinary laboratory of the Ministry of Agriculture, together with a history from the field veterinary inspector who made the *post-mortem* examination. This is then dealt with at once, Negri bodies are searched for, and, if necessary, inoculation experiments are made; in 96 per cent. of cases a decision could be given at once, thus saving those patients who had been bitten much suspense and anxiety, and enabling the medical officer when necessary to advise immediate anti-rabies treatment. The necessity for the Muzzling Order still exists in certain areas, and both medical and veterinary

practitioners must be on the look-out for rabies. But there is no doubt that what has been done before can be done again, and by ridding our island of rabies amongst animals the veterinarian will again render signal aid to his medical brother.

Foot-and-Mouth Disease.

Foot-and-mouth disease is not of quite the same importance, as a disease communicable from animals to man, as those previously alluded to; if neglected, however, it would cause a certain amount of trouble in human beings through the ingestion of the milk. This is not at all uncommon in countries where foot-and-mouth disease is indigenous, and I am told of at least one definite case of contagion in England to-day—an official who was constantly examining mouths and feet. Foot-and-mouth infection comes only from infected cattle, but it may be transmitted to the sheep, goat, and pig, and horses and even fowls are not immune.

In most European countries it is always present, and it is owing to our insular position and the precautions taken by the Ministry of Agriculture that we have kept so free in the past. This country was entirely free from 1895 to 1899, and again from 1903 to 1908, with the exception of two small outbreaks which were easily suppressed. The origin of the present outbreak is very obscure; as the virus is an invisible organism and the disease one of the most insidious and contagious with which we have ever had to deal, its control has presented many difficulties. Had not the outbreak been taken firmly in hand at once it is certain that it would have cost the agriculturist millions of pounds. As an indication of the extent to which it will spread it may be mentioned that in 1892 in Germany no fewer than 1,504,299 cattle, 2,193,157 sheep, 17,782 goats, and 438,262 pigs were affected; in other countries of the Continent it raged with equal violence. Even so recently as the spring of 1919 the north of Italy was visited by a terribly virulent form of the disease, and a great many of the agriculturists of the provinces of Milan, Turin, Tuscany, and Cremona were ruined in consequence, as it affected not only the milking cattle but also the working bullocks.

Mange.

Three mange parasites are found on the horse—a sarcopt, a psoropt, and a symbiote—but it is the two former which give trouble; man may be infected from contact with mangy horses, their grooming tools, feed utensils, etc.; the infection usually occurs on the chest (especially if a hairy man) and the under surface of the forearm and on the hands. Riding a mangy horse has been known to infect men down the inside of the legs and in the pubic region, and during the late war this happened on numerous occasions; knacker-men are frequently infected when employed in skinning mangy horses. Sarcoptic mange is very troublesome to get rid of in the horse; treatment takes several months. The psoroptic variety is much more amenable to treatment. Sulphur, in some form or other, forms the basis of most treatments. Measures had to be taken during the war for dealing with extensive outbreaks of the disease where large bodies of army horses were concerned. In Great Britain it is a notifiable disease.

That mange in the dog and cat is transmissible to man does not seem so generally known as it ought to be; some time ago Dr. Whitfield and myself published the histories of some seventeen cases in which he confirmed the existence of the sarcoptic parasite in the human subject, and I confirmed it in the dog.¹ When treating dogs it is not uncommon to find the owner of a mangy dog complaining of irritation of the skin, usually on the inside of the forearm, where the little dog rests its head when being nursed. The contact of the warm skin causes the mange parasite to leave its original host. In some of these seventeen instances the infection had taken place in the region of the neck and chest owing to the objectionable habit of allowing the little dog to sleep in that situation, and one lady was infected on the abdomen. The lesions produced were described by Dr. Whitfield as small discrete vesicles, slightly smaller than the ordinary eczema vesicle and surrounded by a narrow zone of hyperaemia, very like that of varicella, only about one-eighth of the size. The intense irritation leads to the decapitation of the little vesicles, and their original site becomes covered with either a serous or a blood scab. If left untreated the parasite will live in the human subject for about six weeks, but if treated is readily got rid of. In the dog we

have two varieties of parasite, the *Sarcoptes canis* and the *Demodex folliculorum*; both are infectious to man, and the latter gives the veterinarian endless trouble to cure. Sarcoptic mange yields readily to treatment, but it takes about a month or six weeks to effect a certain cure. If neglected the dog becomes covered with scabs and sores, gets thin and emaciated, has a peculiar mousy odour, and will eventually die. The cat suffers from sarcoptic mange, which reduces the animal to a loathsome and miserable condition. The uncastrated male cat is, in all large towns, a fruitful source of the spread of sarcoptic mange amongst the females, and indeed to other males with whom he is constantly at war.

Ringworm.

All ringworm of the horse, calf, dog, and cat are contagious and give considerable trouble in their treatment. In country districts the calf is the constant source of infection, and in town generally the cat. Dr. Whitfield and others have recorded several cases of infection from animal to man.

Tuberculosis.

Professor Hobday dismissed tuberculosis briefly, the subject being, he said, so large as to call for a separate discussion. Before the war the subject of a clean milk supply and the eradication of tuberculosis from herds was being taken up with vigour; the work must be resumed; it was deplorable that at present milk inspection should so often be merely perfunctory.

THE MENTAL AFTER-CARE ASSOCIATION.

THE annual meeting of the Mental After-care Association, which has done much valuable work during the last forty years in aiding the restoration to ordinary mundane activities of large numbers of poor persons discharged convalescent or recovered after treatment in mental hospitals, was held on February 24th at Bridewell Royal Hospital. Alderman Sir Charles Wakefield, Bt., who presided, after giving examples of the beneficent results of the Association's operations with the very limited funds at its disposal, announced his generous intention to defray the deficit of £70 outstanding at the end of last year. The report was read by Dr. Henry Rayner (Chairman of the Council), and its adoption moved by the Right Hon. Sir William Byrne, Bt., Chairman of the Board of Control, who drew attention to the great value of the timely help and assistance, on discharge, of necessitous patients in consolidating recovery and preventing relapse, incidentally referring to the high character of the services of the staffs of our asylums, sometimes ungraciously impugned by certain irresponsible sections of the press. The motion was seconded by the Bishop of Barking and carried. The re-election of the officers was proposed by another member of the Board of Control, Dr. Hubert Bond, C.B.E., and seconded by the Hon. John Mansfield (Lord Chancellor's Visitor), and the adoption of the balance sheet, which showed an aggregate income for 1920 of £3,061 15s. 8d. (more than half of which was derived from charitable sources), was moved by Mr. Gabain and seconded by Sir George Savage, M.D., Treasurer of the Association. A hearty vote of thanks to Sir Charles Wakefield for presiding and for his generous donation, closed the proceedings.

The following statement of the methods adopted by the Association may give an idea of its varied activities. It facilitates rehabilitation into ordinary social life of suitable cases as follows:

1. By friendly visits, sympathy, and advice (if desired), and by keeping in touch with them as long as they need help in any way.
2. By boarding them out, when thought desirable, for a few weeks with families in the country, under proper care (in cottage homes).
3. By placing them in various institutions in London and other large towns until work can be found.
4. By finding them suitable employment.
5. By giving them grants in kind or in money towards maintenance while seeking work, by providing clothing, by re-decorating or procuring tools when occupation is found.

The offices of the Association are at Church House, Dean's Yard, Westminster, and the Secretary is Miss E. D. Vickers.

¹BRITISH MEDICAL JOURNAL, 1913, i, p. 407.

British Medical Journal.

SATURDAY, MARCH 5TH, 1921.

PUERPERAL MORTALITY IN 1919.

It is a disheartening and almost humiliating discovery to find by the Registrar-General's report that puerperal mortality in England and Wales, both as a whole and as regards puerperal sepsis separately, was greater in 1919 than in any year since 1905.

The number of deaths assigned to pregnancy and childbirth in 1919 was 3,028, corresponding to a rate of 4.37 per 1,000 births, but in order to compare with causes of death under the classification in use up to 1910, 176 deaths allocated to "puerperal nephritis and albuminuria," formerly not distinguished as puerperal, are deducted. This brings the 1919 mortality rate down to 4.12 per 1,000 births, as against an average rate of 3.74 in the ten years immediately preceding.

Unfortunately the Registrar-General finds that "the increase in 1919 is preponderantly due to septic disease," which is very difficult to explain considering the efforts which have been made to educate both medical students and pupil midwives on the need for surgical asepsis in midwifery. The mortality due to sepsis, including phlegmasia alba dolens, in 1919 was 1.76 per 1,000 births, the highest rate since 1905, when it was 1.87. This is particularly disturbing when it is remembered that in 1918 the mortality rate, both from all causes (3.55) and from "sepsis" separately (1.35) per 1,000 births, was the lowest on record, except that in the one year 1913 the deaths from sepsis were 1.34 per 1,000 births.

It would seem that our present methods for preventing puerperal infection are still insufficient. Over seventy years ago (1847) Semmelweis, then an assistant at the Vienna Lying-in Hospital, began an inquiry into the cause of the 10 per cent. puerperal mortality of his hospital patients as compared with those attended at their own homes, and came to the conclusion that the morbid process was a wound infection due to the introduction of septic material by the examining finger. The mortality fell to 1 per cent. after he insisted upon hands being disinfected with chlorine water; but his views were not appreciated, nor were they adopted either here or elsewhere. In 1873 Lister initiated antiseptic methods in surgery, but it was not then realized that the principle should be applied to midwifery. In 1865 Mayrhofer discovered that streptococci were often present in the tissues of women who had died from puerperal fever. In 1872 the Obstetrical Society of London appointed a strong standing committee to "collect evidence on temperature during pregnancy, parturition, and the puerperal state." Its object was to show how puerperal fever might be prevented, and special efforts were made to get midwives properly trained.

In 1905 the Central Midwives Board took over the Society's examination work, and under the able chairmanship of Sir Francis Champneys excellent work has been done; some reduction in the deaths due to puerperal septicaemia ensued, for the death rate from this cause, which had never been less than 2 per 1,000 births (except in 1898, 1.91), gradually fell to 1.42 in 1910 and 1.34 in 1913. More than this

had been expected from compulsory education, examination and registration of midwives, but the necessity of putting 12,521 untrained women, practising as midwives, upon the roll no doubt vitiated the result.

In 1880 Pasteur cultivated streptococci from cases of puerperal fever, and it gradually dawned upon civilization that the mortality was due to infection. Other germs, such as staphylococci and the *Bacillus coli communis*, are sometimes infective agents, but are usually found in combination with streptococci. Dr. Victor Bonney's contention that puerperal sepsis is largely due to infection by the bowel organisms from the patient herself, owing to the parturition and defaecation areas being so closely adjacent, must not be forgotten in this connexion, but it is difficult to accept his statement that "Nature has made the mistake of placing the birth area almost in the middle of this danger zone."

The Registrar-General divides deaths of women in pregnancy and childbirth into two large groups. The first contains 3,028 deaths classed as due to pregnancy and childbirth, and includes deaths from puerperal sepsis and from "other accidents of childbirth." The second group consists of 1,337 deaths of women not classed as due to pregnancy or childbirth, but "associated therewith." The first group consists of (a) conditions which, if detected during pregnancy, could be so dealt with, then or at a later date in the pregnancy, that maternal deaths would very rarely occur. Amongst these may be named (with deaths in brackets) contracted pelvis (47), craniotomy (9), malpresentation (12), hydatid mole (6), retroversion of the gravid uterus (6). (b) Cases many of which probably died for want of prompt or expert treatment, in sudden or unexpected "accidents" of pregnancy or childbirth, such as abortions (121), some probably criminal, ectopic gestation (73), placenta praevia (169), haemorrhage of pregnancy (43), rupture of uterus (20), inversion of uterus (8), inertia uteri (7), abnormal foetus (9), difficult or prolonged labour (44). (c) Deaths due to toxæmia of pregnancy. These are not grouped under that head, but separately, such as uncontrollable vomiting (28), puerperal nephritis and uraemia (131), puerperal albuminuria and Bright's disease (44), puerperal convulsions (420). Many of these cases might have been saved if detected in the early stages of toxæmia by routine urine analysis. (d) Deaths from puerperal fever, including those from phlegmasia alba dolens (51), numbered 1,208. Probably some of the deaths from "puerperal embolism and sudden death" (179) may have been infected cases.

Nearly all these deaths from "puerperal fever" (or as they should now be termed "puerperal infection") should be preventable, for true autogenetic cases are very rare. It would seem that the doctor or midwife concerned must deal with parturition as a surgical process, avoiding all unnecessary contact with the maternal tissues and all rough usage where contact is required; the tissues involved in the birth exit and the areas around must be treated as he would the tissues round a proposed vagino-perineal plastic operation. The modern doctrine is that the accoucheur must wear recently boiled rubber gloves and a sterilized overall on every occasion when examination is necessary. He must recognize early in labour the conditions likely to lead to delay or complication and arrange for the necessary assistance. He and his assistants must be free from dental caries, ozaena, etc., and from all other sources of infection. These aseptic precautions are now taken in all maternity wards and hospitals, and puerperal epidemics do not now occur.

The question arises, therefore, why there is not equal freedom from puerperal infection outside hospital clinics. Most of the midwifery (probably 70 per cent.) of the country is in the hands of midwives, and they ought to be in touch with qualified practitioners. Midwives are now well instructed, and their work is carefully inspected and supervised. Many writers, including teachers of obstetrics in every school of medicine, have repeatedly drawn attention to the subject during recent years. They have discussed the prevention of infection and better education in practical midwifery, so that students may be prepared not only to anticipate complications by ante-natal supervision, but be able to deal with them effectively when they arise. To do this, it is maintained, the student must have seen women delivered by experts in special lying-in wards which are equipped as fully as operation theatres for all emergencies, and must have seen all the minor operations of version, forceps, etc., performed by skilled teachers and have had some opportunities for personal experience.

Every general practitioner practising midwifery should be an expert. Obstetrics is not a speciality which can be in the hands of a few, like some other specialities, for at any moment the accoucheur, perhaps soon after being qualified, may be called upon to deal with a sudden emergency during pregnancy, childbirth, or the puerperium; such a case will not be met by a consultation in a few days' time; it must be dealt with at once. It is almost impossible with the present supply of maternity beds to enable this experience to be gained during a student's curriculum. This is perhaps more particularly true of London. Every general hospital should have a maternity ward or be associated with a lying-in hospital.

Even if a doctor has had special midwifery training, he—and perhaps still more the midwife—is seriously handicapped, both as regards sepsis and space, by the conditions of the rooms where women are confined in poor and middle class practices. Dr. Victor Bonney's graphic word picture of such a bedroom loaded with furniture and oddments is not exaggerated, and the difficulty of its conversion into an aseptic lying-in room is not overstated. Yet there is at present no possibility of getting all parturient women, or even all primigravidae, into a local cottage hospital or maternity ward.

If ante-natal supervision were universally adopted, and complications anticipated, and if there were a more definite linking up of patient with midwife, doctor and hospital, the incidence not only of infection but of all other accidents of pregnancy and childbirth would be greatly diminished, and puerperal mortality and morbidity would continue to decrease.

The second large group of 1,337 deaths are those "not classed as due to pregnancy and child-bearing, but returned as associated therewith." Inclusion of these deaths raises the proportion of deaths caused by or associated with pregnancy and childbirth to 6.3 deaths per 1,000 births. These deaths may be divided into two smaller classes. The first class contains deaths due to conditions, usually acute, which do not arise from, but complicate, the pregnancy or childbirth, such as influenza (585), lobar pneumonia (76), bronchopneumonia (34), scarlet fever (10), appendicitis (10), intestinal obstruction (10), acute phthisis (13), enteric (3). Some of these influenzal deaths may have been cases of puerperal infection: the distinction is sometimes very difficult. The second class consists of deaths due to the association of pregnancy or childbirth with pre-existing, usually chronic, pathological states, such as heart disease (177), pulmonary tuberculosis (66), Bright's disease (37), anaemia (21), epilepsy (2),

sypphilis (7), cancer (6), diabetes (6). Cases in both classes, if in hospital, would be usefully seen by experts in both obstetrics and in medicine or surgery as indicated by the particular complication present.

THE PANDEMIC OF INFLUENZA, 1918-19.

THE Ministry of Health has come in for a great deal of criticism in the lay press, some of it undeserved and apparently due to political considerations; some it brought on itself. We warned the Ministry from the first that the introduction of its Miscellaneous Bill was a mistake, for reasons now apparent. But the medical profession looks to the Ministry for much more than legislation. In fact, legislation is only an incidental function; its important duties are the review of administrative effort in the light of increasing knowledge, and the collection and dissemination of information, especially with regard to epidemics. An excellent illustration of the intelligence work the Ministry of Health can do is afforded by the recent report on the pandemic of influenza 1918-19.¹

This intensive study of a devastating historical epidemic in all its aspects is summarized in a philosophic introduction by the chief medical officer, Sir George Newman, who again emphasizes the unitary character of the problems of health and disease, and points out that the only sure defence against sudden and terrible epidemics is to raise the whole standard of life not only in this country but in all countries. The report is especially rich in its epidemiological aspects, which are dealt with in an article published at p. 348: the clinical section contributed by Dr. Herbert French will appeal very directly to the medical practitioner; it covers familiar ground and its conclusions can be tested by the results of his own experience.

The pandemic consisted of a first wave in June, 1918, of a comparatively mild character—the influenza of the three-day fever type—with sudden onset and fever running up to 103° or 104° F., and a rapid convalescence, so that the great majority of the patients were fit for work by the end of a week; there was little tendency to complications, and only those disposed to bronchial catarrh by chronic bronchitis or emphysema suffered from pulmonary infection. Very different was the second wave in the autumn with a recrudescence in February, 1919, for though the general type of cases was much the same as in the first wave, there was a tendency to severe and fatal pulmonary complications. Broadly speaking, it is estimated that out of 1,000 persons attacked during the second wave fully 800 had an ordinary attack of uncomplicated influenza, very commonly with epistaxis, and perhaps rather more severe than the three-day fever of June, 1918: the remaining 200 were severely ill with pulmonary complications, and of these about 80 (or 40 per cent.) died. This may also be illustrated by Sir Robert Hill's² figures from the Royal Navy, where the first wave was accompanied by 0.4 per cent. of complications and 0.03 per cent. mortality, whereas in the autumn wave the incidence of complications was 6.8 per cent. and of deaths 2.8 per cent. The explanation tentatively suggested by Dr. French for this remarkable seasonal change of type is that whereas the *Bacillus influenzae* alone may be responsible for the 800 mild cases, one or more

¹ Report on the Pandemic of Influenza, 1918-19. Reports on Public Health and Medical Subjects, No. 4. Ministry of Health, 1920, pp. 577, 108.

² R. Hill. *Journ. Roy. Sanit. Inst.*, 1919-20, xl, 21.

additional organisms are virulently associated with Pfeiffer's bacillus in the 200 grave cases; in other words, while the mild cases are examples of influenza alone, the grave cases may be described as influenzo-pneumococcic, influenzo-streptococcic, or influenzo-pneumo-streptococcic septico-toxaemia. This attractive solution is, of course, subject to the moot question of the causal relation of Pfeiffer's bacillus to influenza, and although a number of observers—for example, Pildes and McIntosh—incline to this view, Sir Frederick Andrewes (vide p. 348) concludes that the claim for *Bacillus influenzae* that it is the primary cause remains unproven, and that it should be included among the secondary invaders "without prejudice to its possible claims to be regarded also as the primary cause of the disease."

In the cases with pulmonary complications the most dreaded manifestation was the "heliotrope" cyanosis; it occurred in less than half the cases, but was followed by death in about 95 per cent. Although this heliotrope cyanosis was noticeable on account of its frequency during the pandemic, it was not a new phenomenon, for it had been noted in small epidemics of "purulent bronchitis" in 1916 and 1917. The only similar cyanosis—the variations of which are well illustrated in three coloured plates from the paper written in collaboration with Abrahams and Hallows,³ and obviously forming the basis of this report—is that seen in gassed patients, who, however, are much distressed, whereas the influenzal cases are not to anything like the same extent. The cyanosis is not due to cardiac failure or to chemical changes in the blood, and is not relieved by bleeding; it is the outcome of anoxaemia caused by widespread and extensive albuminous exudation into the alveoli and interstitial tissues of the lungs. The pulmonary complications—often with physical signs of slight bronchitis when more were anticipated—may appear at any stage. They may constitute the initial symptom without any preliminary influenzal manifestations and then simulate ordinary lobar pneumonia; or they may come on after nearly a week's illness, or even during convalescence. Most often they supervened after a day or two of simple influenza; a sudden and rapid change for the worse then took place, with evidence of pulmonary lesions, which were often so fulminating as to prove fatal within forty-eight hours, apparently from a generalized and extremely virulent toxæmia or septicaemia. The amount and character of the sputum varied much; there might be 8 to 10 oz. of pus daily, as in "purulent bronchitis," or there might be little or none; it might be frothy or rusty, and the same patient might bring up sputum of different character on successive days. The physical signs also showed wide diversities in cases otherwise alike, and, generally speaking, the paucity of abnormal signs was in striking contrast to the degree of illness. In most cases the classical signs of pneumonia never appeared, but pleuritic friction was commonly present.

The report contains an account of the morbid anatomy and histology of the disease, which may be read in conjunction with the masterly description of the pneumonia in the United States army camps during the winter of 1917-18 by Professor W. G. MacCallum,⁴ of the Johns Hopkins Hospital, who says that the changes were practically the same as those described by Drs. Abrahams, Hallows, Eyre, and French in 1917, the main differences being the rarity of pleurisy and the predominant part played by the influenza bacillus in the Aldershot cases.

MacCallum describes two main types which were often combined, namely, interstitial bronchopneumonia and lobular pneumonia, both due to the *Streptococcus haemolyticus*. Dr. French insists that the lung changes were practically never those of ordinary croupous pneumonia, but a complex and variable mixture of inflammatory lesions of which bronchopneumonia formed a part only, also showing acute pleurisy in many cases, diffuse haemorrhagic areas and infarcts, miliary abscesses, purulent bronchiol-ectasis, oedema, collapse, and emphysema; and to prevent confusion with pneumonia the term "pneumonitis," with mention of the more prominent lesions in the different types, is suggested. Stress is also laid on the existence of a general toxæmia or even septicaemia with morbid changes elsewhere, especially in the kidneys. In the section on treatment, while the failure of various methods, including vaccine and serum, is frankly admitted, the hypodermic injection of serum from convalescent patients, as employed by Dr. Huff-Hewitt,⁵ is referred to as promising and deserving a full trial. This has, in fact, been employed in the American navy⁶ on a considerable scale for the pulmonary complications of influenza, especially by McGuire and Redden, who treated 151 patients with a mortality of 6, or 4 per cent.

COMPARATIVE MEDICINE.

THE lessons that might be learnt from the results of injury and disease in plants was the subject of one of Sir James Paget's most striking essays, delivered as an address to the Pathological Section of the British Medical Association at Cambridge in 1880. Eight years later Sir Clifford Allbutt made an appeal for the study of comparative medicine the main topic of his Address in Medicine to the Association at its meeting at Glasgow; in his Presidential Address to the Association last year he told us that the Glasgow appeal found "no response, hardly an echo." In 1880 Sir Henry Acland, then Regius Professor of Medicine in Oxford, advocated the foundation of a chair in general comparative pathology, and the Regius Professor of Physic at Cambridge forty years later has to declare that "without an institute of comparative pathology in Cambridge our range of vision and work is contracted." The institute he contemplated would be concerned not only with those diseases enumerated by Professor Hobday in the address he gave to a recent combined meeting of the Royal Society of Medicine and the Central Branch of the National Veterinary Association, as reported at page 351, but with many other diseases of animals, and with those of crops and forests. In a letter addressed to Professor Hobday on the occasion of his recent lecture Sir Clifford Allbutt recalls how, since his Glasgow address in 1888, he has been speaking and writing to urge the consolidation of the study of medicine in all its branches, since without the comparative method the progress of our art and its sciences cannot make active growth on the larger lines. He goes on to point out how there is far more in the matter than merely the peril to men from animal diseases, for only in the light of disease as a whole can its parts be adequately known and its intimate laws understood. He again reminds us that, in order to realize the need of the comparative method, it is only necessary to look at the fertile results of the comparative method in other studies—in comparative anatomy and morphology, in history, languages, and religion, and indeed in every subject of thought which has advanced far enough to avail itself of the method. At Cambridge there is in the field laboratories, agricultural department, and so on, much of the groundwork for such an institute of

³ *Lancet*, January 4th, 1919 pp 1-11.

⁴ W. G. MacCallum: Monographs of the Rockefeller Institute for Medical Research, No. 10, April, 1919 (BRITISH MEDICAL JOURNAL, 1919, II, p. 415).

⁵ Huff-Hewitt: BRITISH MEDICAL JOURNAL, I, 1919, p. 575.

⁶ Annual Report of the Surgeon-General, United States Navy, for the fiscal year 1919; p. 418; Washington.

comparative pathology, but money is wanted. Let us share with him the hope that the pedigree stock-breeders, racing men, nurserymen, foresters, and others interested in such matters who are now suffering enormous pecuniary losses may endow Cambridge with the means of establishing such an institute adequately equipped for practical and theoretical work in comparative medicine, both of plants and animals. Short of this something may be done by recognizing, first, that experts on diseases of animals and plants ought to come together for discussion, and, secondly, that in our great universities are many students who, if opportunity were afforded, would find themselves attracted by the larger field and the endless variety of experience and opportunity of research which comparative pathology would offer to their enterprise.

THE ROYAL SOCIETY.

AMONG the fifteen names recommended by the Council of the Royal Society for election to the Fellowship are two pathologists and one ophthalmologist. Dr. John C. G. Ledingham, C.M.G., has been chief bacteriologist to the Lister Institute, London, since 1909, and is reader in bacteriology in the University of London. He had a brilliant career as a student at Aberdeen, and after a period of post-graduate study at Leipzig and the London Hospital, became assistant bacteriologist to the Lister Institute in 1905. His contributions to bacteriological literature, some of which have appeared in our columns, are numerous, and he is the author, with Dr. Arkwright, of a book published in 1912 on *The Carrier Problem in Infectious Diseases*. Dr. Georges Dreyer, who is of Danish birth, graduated at Copenhagen, and has been professor of pathology at Oxford since 1907. He is well known for his work on immunity. Mr. John Herbert Parsons, C.B.E., F.R.C.S., surgeon to the Royal London Ophthalmic Hospital and ophthalmic surgeon to University College Hospital, has made many important contributions to ophthalmology. Among the other new Fellows are Mr. George Udny Yule, C.B.E., university lecturer in statistics, Cambridge, and Dr. Wilfred Agar, lecturer in zoology in the University of Glasgow.

LETHARGIC ENCEPHALITIS.

So far as statistics are available, it would appear that the number of cases of lethargic encephalitis in Great Britain tends to diminish: in London 29 were notified in the last week of January, and only 9 in the third week of February. The Ministry of Health has, however, considered it desirable to issue a circular letter to medical officers of health asking them to assist in the investigation of the disease, both by direct inquiry and by supplying information obtained through the courtesy of the notifying practitioner. The circular is accompanied by a memorandum, dated February, 1921, in which lethargic encephalitis is defined as a general infectious disease, characterized by certain manifestations originating in the central nervous system, of which the most frequent and characteristic are progressive lethargy or stupor, and a lesion in or about the nuclei of the third pair of cranial nerves. As is now well known, a large number of cases of the disease do not conform to this type, and it is particularly important to remember that some begin with excitement; such cases may from the first or from an early stage be accompanied by muscular jerks and by severe pains in the limbs, due to affected nerve roots. In a typical case, after a period of incubation the duration of which is not known, there ensues a prodromal stage, lasting a week or even two or three weeks, and characterized by somnolence, headache, double vision and general lassitude. The patient may complain of soreness or dryness of the throat, and sometimes vomiting and diarrhoea occur. The temperature rises usually to 101° or 102°. Other symptoms at this stage include asthenia, stupor (alternating often with

nocturnal delirium), difficulties in speech and spasmodic twitchings of the face and limbs, such as occur earlier in the unusual so-called myoclonic cases. There is no characteristic rash, but transient skin lesions are often present, the most frequent being erythema; petechiae may develop or an eruption, recalling that of measles or scarlet fever. As is well known, the most common nervous sign is diplopia, often accompanied by ptosis; sometimes there is complete ophthalmoplegia, external or internal. Paralysis of the face, tongue and pharynx, increasing rapidly or gradually in intensity, is not uncommon, but paralysis of the limbs and sensory troubles are exceptional. Retention of urine may occur, but incontinence is more common; it may be accompanied by loss of control of the anal sphincter. Death, which is commonly preceded by an increase in delirium and stupor, merging into coma, appears to be due to paralysis of the respiratory nervous centres. The stupor may clear away in a few days or persist for several weeks, even as many as eight. Recovery may ensue even after these long periods: the mortality of cases recognized as lethargic encephalitis in 1919 was about 50 per cent. The real mortality is no doubt lower, as it is not easy to recognize the true nature of mild or abortive cases. Diagnosis is, indeed, often difficult, but local palsies, or, in myoclonic cases, root pains, will suggest the possibility of lethargic encephalitis. It has been shown experimentally that the disease is communicable by intracerebral and intraperitoneal injections, but the infectivity is low. Multiple cases in the same household have occurred, a striking example being afforded by the outbreak at the Home at Derby noted in our columns of February 19th, p. 277. Usually the disease appears to be sporadic, but there is good reason to think that the recognized cases are connected through persons who suffer mild attacks presenting only persistent apathy, headache, and lack of facial expression, or only such common symptoms as soreness of the throat, naso-pharyngeal catarrh, and headache, accompanied, possibly, by vomiting or diarrhoea. If occasion occurs to examine such cases carefully, a short feverish period may be detected, or there may be transient interference with vision, the pupils being dilated but insensitive to light. If diplopia, facial paralysis, or ptosis, even though transient, occur, there can be little doubt about the diagnosis. As the disease is infectious, the patient, if kept at home, should be well nursed and isolated as far as possible from other members of the household. Removal to hospital, however, is much to be recommended. The only drug which has been supposed to influence the course of the disease is hexamine: its efficacy is very doubtful, but if given in moderate doses it can at least do no harm. The withdrawal of cerebro-spinal fluid by lumbar puncture is often followed by diminution of stupor, and in some cases repetition of the operation has been beneficial. The Ministry of Health will continue to examine specimens of cerebro-spinal fluid forwarded to it through the medical officer of health.

THE CONTROL OF THERAPEUTIC SUBSTANCES NOT AMENABLE TO CHEMICAL ANALYSIS.

THE principle which hitherto has guided the General Medical Council in the adoption of standards for articles in the *British Pharmacopœia* has been to prescribe only such chemical and physical tests of purity and composition as were capable of being carried out by skilled pharmacists or analysts in any part of the Empire; in the preparation of the last edition the Pharmacopœia Committee came to the conclusion that to direct tests which called for the employment of animals, would be to require conditions at variance with this principle. At the same time the importance was felt of fixing some authoritative standard for such therapeutic agents as serums and vaccines which could at least be referred to in the *Pharmacopœia*. In 1909 a resolution was accordingly

¹ H.M. Stationery Office. Through any bookseller, 1d.

passed by the Pharmacopœia Committee authorizing the President of the General Medical Council "to approach the Government with a suggestion for the establishment of a public institution for the pharmacological standardization of potent drugs and of serums." The Government were approached accordingly, but it was not found possible to take immediate steps in the direction indicated, and it became evident that nothing could be done in time for a fresh edition of the *Pharmacopœia*, which ought to have been published in 1912, but did not appear until 1914. Standardization of such substances as vaccines, serums, antitoxins, and analogous products, is left at present wholly to the private enterprise of manufacturers, and each maker is free to adopt his own conception of adequate standards. Hence any guarantee of potency and authenticity entirely depends upon the reputation of the supplying firm. The reputation of the British manufacturers of these substances is deservedly high, but there are obvious disadvantages attaching to the present state of affairs, especially as these products may be imported into this country without check or guarantee of any kind. Manufacturers have perforce had to adopt foreign standards to which reference can be made in cases where biological assay is necessary, as there are no British standards in existence. Accordingly, in April, 1920, the Minister of Health appointed a committee to consider and advise upon the legislative and administrative measures to be taken for the effective control of the quality and authenticity of such therapeutic substances as cannot be tested adequately by direct chemical means. The substances included may be classified into: (a) a group comprising the bodies conveniently described in the United States Regulations of 1919 as "biologic products"—that is, vaccines, antitoxins and the like; (b) a group of potent synthetic remedies, such as salvarsan and its analogues; (c) a group corresponding more nearly with the ordinary definition of "drugs"—for example, digitalis, strophanthus, ergot, cannabis indica, and pituitary gland. Most of the substances in the last group are included in the *British Pharmacopœia*, and certain primitive tests and methods of identification are therein provided for them, but there is a considerable volume of opinion that these tests are far from adequate as standards of therapeutic efficiency, and although the application of physiological standards to substances in this group is hardly of the same importance as in the two former groups, such standards would be accessory guarantees of efficiency. The Committee examined a large number of witnesses representing not only scientific bodies, but also firms actually engaged in the manufacture and sale in this country of the substance under consideration. As the result of the investigations the Committee's report, which is now published,¹ recommends that therapeutic substances which cannot be tested adequately by chemical means should be subject to supervision and control under the authority of a committee of the Privy Council assisted by an advisory committee. There should be a central laboratory under Government control, wherein standards would be prepared and maintained, research on the subject carried out, and tests made to ascertain that the products issued by manufacturers conform with the standards laid down. It is recommended that the Medical Research Council, which already possesses the requisite organization, should be responsible for this central laboratory. The method of control should include the licensing of manufacturers, inspection of their plant, premises, and processes, and the testing of the finished products, preferably from samples taken from makers' stocks or bought in the open market, leaving to the manufacturers the primary responsibility for securing that the products conform with the prescribed standards. Products made abroad should be subject to restrictions similar to those applying to products made in the United

Kingdom, and licences should be granted to approved manufacturers, while in addition steps should be taken to ensure that each consignment imported attains the standards laid down for similar products of home manufacturers.

DISABLED SOLDIERS AND THE DIAMOND INDUSTRY.

IN view of the importance of the question of employment for disabled soldiers, the work that is being done at the Bernard Oppenheimer Diamond Works is of interest. These consist of a series of fine buildings at Brighton, capable of holding 2,000 workmen, and of subsidiary branches at Cambridge, Fort William, and Wrexham, which can train 250 additional men. The industry is a new one in England, and the work is being carried out practically in its entirety by disabled men. Nearly half of the men are suffering from disability due to amputations, while the disabilities of the majority of the others are due to gunshot wounds, either of the shoulder and arms, or of the thigh and legs. The undertaking has passed the experimental stage, and is now on a sound financial basis. Much credit is due to Sir Bernard Oppenheimer for the risk he undertook in staking, not only his reputation as a successful diamond merchant, but also the large outlay in capital which was necessary. Credit is due also to the Ministry of Pensions and the Ministry of Labour for their co-operation in endeavouring to smooth over many difficulties which at first must have been almost insurmountable. At the time of the establishment of the first wing of the factory the greatest difficulty and inconvenience was found in carrying on concurrently the training and at the same time the necessary medical treatment of the men. It was necessary for them to attend at a hospital or private clinic, sometimes daily or twice daily, at hours which were invariably the regular working hours, with the result that each treatment meant the loss of half a day's work. As there were occasions when 25 per cent. of the employees were absent undergoing treatment, it was manifestly impossible to train men under these conditions, and with the approval of the Ministry of Pensions a clinic was established on the premises. The clinic consists of one room for massage and electrotherapy, one for remedial exercises, one for x rays and high-frequency and diathermy apparatus, one room as a surgery, a waiting-room, a room for the medical referee, and another for the works doctor. The saving of time by having the clinic on the spot is enormous; there is no waste, as each man has his definite hour for treatment or comes when sent for by the orderly. On an average 60 to 70 pensioner-employees receive massage, electrical, remedial, or combined treatment every day. The results have been very satisfactory, and some twenty patients are discharged each month, benefited or cured, while in the surgery twenty cases on the average are dressed every day—for discharging sinuses, stump infections, or other conditions due to war service. The kind of treatment and its duration are left entirely in the hands of the medical referee, Colonel Langmuir Watt, C.M.G., and there is no attempt to carry on treatment for conditions other than those due to war service, except first aid in the case of accidents. The clinic has also been made a limb-fitting centre; a stock of the more perishable parts of artificial limbs is kept in the clinic and issued as required, and there is little or no delay, as minor repairs take only a few hours, and more serious repairs never longer than from one to two weeks. New limbs are obtained as rapidly as if the men were at Reelampton. The great problem still to be solved, Colonel Langmuir Watt tells us, is the provision of a working limb—as distinct from a walking limb—which can permit of its wearer sitting down for four hours at a stretch without causing pain or discomfort, or overheating of the stump. A hut adjoining the works has just been erected by the British Red Cross Society and the Order of St. John of Jerusalem, where they will be

¹ Report of the Departmental Committee on Control of Certain Therapeutic Substances. H.M. Stationery Office, 1921. Price 2d. net.

able to carry on satisfactorily the fitting and manufacture of peg legs, surgical appliances and surgical boots. Arm amputations are not very suitable for the work, but even these cases have been successfully trained, some fitted with a special mechanical appliance invented in the works, while there are many men with more or less useless arms, due to such conditions as ankylosis or paralysis, earning average wages. The actual work of diamond polishing is naturally very exacting, and the men must possess good eyesight, sound nervous systems, and intelligence rather above the average. All applicants for training have to undergo a careful practical test of their fitness; this is of benefit not only to the Ministry of Labour, but also to the works, as it tends to prevent men from being released after a few days' trial with the necessity of finding a new training for them. Canteens and a recreation room have been provided for the men. Their period of training is eighteen months, though actually after six months of works attendance a man is supposed to be able to earn his living. During these six months the sum of £2 a week is paid by the Ministry of Labour, at the end of that period a man goes on works pay, the minimum being £2 a week—of course entirely independent of his pension—from which he may rapidly rise, as many of the men have done, to £5 or £7 weekly. Medical practitioners who are interested in this subject are invited to visit the works.

DECEREBRATE RIGIDITY IN MAN.

It has been thought and even stated in some quarters of recent years that medicine can expect to learn little more from purely clinical observations. Neurology, however, is fortunate in being a branch of medicine in which original clinical observations continue to lead to great increase in our knowledge of the functions of the central nervous system as a whole. And we are proud to be able to say that in this field British neurology can fairly claim a prominent place. Dr. Kinnier Wilson's¹ recent contribution is a shining example, if such were needed, of the value of careful and prolonged clinical study of symptoms which, though familiar to many, have hitherto eluded satisfactory explanation. He has drawn a luminous comparison between the experimental decerebrate rigidity of animals (following transection of the brain stem through the mesencephalon) and certain cases in man "in which there is evidence of withdrawal of cortical control in the form of unconsciousness or semiconsciousness coupled with the appearance of tonic rigidity of the trunk or limbs, with exacerbations in the form of tonic or postural fits." The first group of cases quoted are examples of decerebrate rigidity combined with tonic fits, and pathologically comprised a tumour of the frontal lobe with haemorrhage into the ventricles, a tumour of the mesencephalon, general septic meningitis with some internal hydrocephalus, a case of cerebral haemorrhage with extension into the ventricular systems of the brain, and a case of tuberculous meningitis with moderate internal hydrocephalus. The description of these cases is very full and vivid, and the author points out how the tonic posture was maintained, while the actual fits were an accentuation, so to say, of the already existing decerebrate position. The absence of any clonic element in the fits is emphasized. Tonic or "cerebellar" fits, as they were originally called, may occur without the maintenance of the decerebrate posture, and a very striking example of such a condition is given in full. Their association with hysteria is also pointed out, the position of opisthotonos with extension of the legs and extension and pronation of the arms being a well recognized phenomenon. Of particular clinical interest are those cases which exhibit a unilateral or fragmentary decerebrate attitude in one limb only. The so-called decerebrate attitude of the head may be thus explained. The extreme pronation of the

hand which is found, for example, in athetosis or chorea is held by the author to be but a fragment of the complete picture of the decerebrate posture. In explaining the pathogenesis of this condition tribute is paid to the theory of "cerebellar influx" propounded as long ago as 1877 by Hughlings Jackson. The numerous experimental researches of Sherrington, Graham Brown, Weed and others, however, point to the conclusion that the mesencephalon is the principal site responsible for the maintenance of the decerebrate posture; and the red nucleus is credited with particularly important functions in this respect. We are promised a further study on the part played by the basal ganglia in the regulations of these functions. No student of neurology can afford to miss this communication, to which a full bibliography is attached; and further contributions will be awaited with interest.

THE RETARDED CINEMA.

LAST week Dr. Gustave Monod-Walter gave a demonstration at the house of the Royal Society of Medicine on the cinematograph, which excited so much interest that he consented to repeat it this week. The films were taken at the rate of about 300 pictures to the second, slowed down when exhibited to perhaps fifteen or twenty in a second. In this way every detail of movement can be observed, and it has been hoped—a hope not yet realized—that the method would be of value in the study of movement. The first film was of a type fairly familiar in this country—jumping and putting the shot; and the second, of the isolated mammalian heart, shewed in a film what most British students of to-day have seen in the laboratory. The last film, taken at the Institut Marey, Paris, was an analysis of the drive, approach and putt as performed by the French golf professionals Lafayette and Botcazou—the latter one-armed; this film excited, it must be confessed, a good deal more interest than the others, partly, perhaps, because of its novelty, but partly because the majority of the audience appeared to be golfers. A study of it may perhaps help the inexperienced player or he who is off his game; but we are inclined to agree that the object to be attained rather than the means of attaining it should be had in mind, or, as Dr. Monod-Walter said, the player should trust to his imagination rather than to his will.

MEDICAL SCHOLARSHIPS FOR SERBIAN GIRLS.

A DRAWING-ROOM meeting was held on February 10th at 28, Kensington Court, by kind invitation of the Lady Swaythling, in aid of a scheme for raising a fund to endow one or more scholarships for Serbian girls in connexion with the London School of Medicine for Women and the Royal Free Hospital. The successful candidates will be required to undertake to return to practise in their own country when qualified. The speakers were Sir Willoughby Dickinson, Dr. Mary Scharlieb (chairman of the fund), Dr. Dickinson Berry (the honorary secretary), and Mrs. Carrington Wilde. The scheme was recommended as a fitting memorial to the work of medical women in Serbia and as a means of helping to maintain the cordial feelings between Serbians and Britons produced by intercourse during the war. The outlook of Serbian women, it was stated, has enlarged greatly since the beginning of the war. There is a keen desire among them for higher education, and especially for a medical career, which many have already taken up. To study in England is said to be the highest ambition of every Serbian student, male or female. Sir Willoughby Dickinson drew attention to the value of scholarships in drawing nations together and teaching people of various nationalities to know one another—factors of the greatest importance in the future peace of the world. Mr. Gavrilovitch, the Serbo-Croat-Slovene Minister, supported the scheme and proposed a vote of thanks to Lady Swaythling for holding and presiding at the meeting.

¹ S. A. Kinnier Wilson, *Brain*, vol. xliii, Part iii, 1920.

THE centenary of the death of Keats was celebrated at Hampstead by a pilgrimage to various places more or less directly associated with his residence there, and in Rome by a visit to the English cemetery. Keats took the diploma of Licentiate of the Society of Apothecaries on July 25th, 1816. There hang in the Court Room of the Apothecaries' Hall his portrait, and an original abstract from the candidates' entry book giving particulars of his apprenticeship, attendance at lectures, and hospital practice. Keats was a student at Guy's Hospital, and for part of the period that he was attending there lived in lodgings at Bird-in-Hand Court, Cheapside.

LORD MILNER'S Fund for the London School of Tropical Medicine now amounts to £117,000. The school obtained its new buildings, including a hospital, in Endsleigh Gardens, by means of a gift of £100,000 from the Red Cross Society. Lord Milner's Fund, which it is hoped will reach £150,000, is to provide for the maintenance of the school and for research. It was in 1899 that Lord Milner's great predecessor as Colonial Secretary, the late Mr. Joseph Chamberlain, made his appeal to the public for a capital sum to establish the school.

WE regret to announce the death, in his 92nd year, of Sir Charles A. Cameron, M.D., who for many years had been chief medical officer of health and public analyst for the city of Dublin.

Medical Notes in Parliament.

Dangerous Drugs Regulations.

MR. CLOUGH asked the Home Secretary, on February 24th, what was the result of the submission of the preliminary draft of the Regulations under the Dangerous Drugs Act by the Home Office to the Pharmaceutical Society of Great Britain, the Pharmaceutical Society of Ireland, the General Medical Council, the Royal College of Physicians, and the Royal College of Surgeons; whether, prior to the publication of the draft Regulations by the Home Office any, and if so which, of those bodies had indicated their approval of the draft; and whether any, and if so which, had submitted objections. Mr. Shortt said the result of the communication of the preliminary draft in November last to the bodies mentioned for their observations was as follows: The Royal College of Physicians and the Royal College of Surgeons considered the draft satisfactory and offered no observations, except that the Royal College of Physicians thought the minimum limit in the case of cocaine (which is fixed by the Act and cannot be altered by Regulation) too high. The General Medical Council also approved the Regulations, but asked that the directors of research laboratories might be included among the classes of persons who are authorized by the Regulations themselves to be in possession of the drugs. The Pharmaceutical Society of Great Britain replied by a letter maintaining that the proposal in the Regulations to prohibit the sale of the drugs to the public except on a medical prescription was *ultra vires* of the Act, and proposing that before going on with the Regulations the Government should appoint a Committee to consider the desirability of separating the functions of prescribing and dispensing. The reply of the Pharmaceutical Society of Ireland, which was not received till after the draft had been published, submitted objections on various points.

Indian Medical Service.—Mr. Gwynne asked, on February 23rd, whether the Secretary for India was aware that the Indian Medical Service had received neither the benefits of the accelerated cadre promotion granted in the British Army and the Royal Army Medical Corps nor the accelerated time promotion granted in the Indian Army; whether the reason given for the exclusion of the Indian Medical Service from the British Army and Royal Army Medical Corps cadre acceleration to lieutenant-colonelcy was because the Indian Army did not have it, and from the Indian Army time scale acceleration to field rank because the Royal Army Medical Corps did not have it. Mr. Montagu said that he found some difficulty in understanding the question, and asked for particulars of any specific case on which it was based. He offered assurance that there had been no discrimination against the Indian Medical Service.

The Spahlinger Treatment for Consumption.—Asked by Mr. Lynn, on February 23rd, for information regarding the Spahlinger treatment for consumption, Dr. Addison said he had made full inquiries regarding this supposed remedy for tuberculosis, but it was clear that much further investigation and experience would be necessary before accepting the claims made for it. It appeared that as long ago as 1913-14 the serum in question was prepared. It was tried by several hospital physicians, but there was not yet sufficient evidence of its therapeutic value, nor had the trials been sufficiently extensive to justify any definite and reliable conclusions. He understood that a supply of serum was not likely to be available for some months, and that on account of the secrecy maintained as to its constitution and method of preparation, it had hitherto been found impossible for the recognized research laboratories in this country to investigate its effects.

Industrial Fatigue Research Board.—Captain Elliot asked, on February 24th, whether the Treasury had ordered the Industrial Fatigue Research Board to be wound up by March; whether this body had recently issued a most valuable report on conditions in the steel making industry, indicating methods for securing greater efficiency in production; and whether it was the case that the dissolution of this body now would mean the loss of all the work and money spent in getting it to the present point, when it was beginning to show a return. Dr. Addison replied that the matter was under consideration, and he hoped soon to be able to give a definite reply. The Government entirely shared his views as to the report in question.

Salaries at the Ministry of Health.—Sir T. Polson asked the Chancellor of the Exchequer, on February 23rd, whether the salary of the First Secretary of the Ministry of Health had recently been increased from £2,000 to £3,000 per annum, and that of the Second Secretary from £1,700 to £2,000, and on what grounds these increases had been made. Mr. Chamberlain replied that the salary of the First Secretary to the Ministry of Health had been increased from £2,000, plus £750 bonus, to £3,000, plus £500 bonus, and that of the Second Secretary from £1,700, plus £750 bonus, to £2,200, plus £500 bonus, in pursuance of the recommendation of a committee appointed by the Government to advise them as to the emoluments which should attach to the principal permanent posts in the Civil Service. Mr. Asquith had acted as Chairman of the Committee.

Medical Records.—Sir Douglas Hall asked, on February 24th, whether the earlier system of record cards of insured patients proved to be useless and were practically unexamined, large quantities of cards being sold as waste paper, and whether Dr. Addison anticipated a better fate for the new cards. Dr. Addison replied that the cards under the earlier system of record were by no means useless; they were sold only after having served their purpose; but their value for clinical purposes was gravely impaired because at the end of every year they were surrendered and the particulars as to the names of the patients and their illnesses separated. It was because of this inherent defect in the old cards that the new records had been designed by a committee mainly composed of members of the medical profession, who gave fuller place—and in his view rightly so—to the clinical objects of the record, and so designed the form which might serve as a continued record of insured persons' illnesses. These records would undoubtedly be of great value, and the keeping of them would give less work than the old records. Sir D. Hall asked what was the position of a panel doctor who made an inaccurate statement regarding the diagnosis of a disease on the new record of an insured patient, whereby the patient was subsequently damaged; and whether, if the panel doctor was liable in such cases to pay damages, provision would be made to indemnify him in respect of an error in a document which he was compelled to compile under conditions which often rendered accuracy difficult or impossible. Dr. Addison said he did not understand what particular contingency Sir D. Hall had in mind, but he was advised that, in the absence of negligence on the part of the doctor, no liability for damages could arise in this connexion. Dr. McDonald had previously asked, on February 23rd, if, in order to obtain true health statistics for the nation, Dr. Addison purposed ultimately issuing record cards to the whole population, and not, as at present foreshadowed, limiting the issue to insured persons. Dr. Addison replied that he did not think it was practicable to give effect to the suggestion.

Insurance Doctors' Duties.—Mr. R. Young asked, on February 23rd, whether the attention of Dr. Addison had been drawn to the case at Old Street Police Court, where it was elicited that a panel patient had to pay 2s. 6d. for each visit she made to the doctor because she could not afford to leave her work to attend at the surgery during the hours fixed for panel patients. Dr. Addison said his attention had been called to the case, which, he learned, was under investigation by the London Insurance Committee.

National Insurance Contributions.—In answer to Mr. W. Thorne, Dr. Addison said, on February 28th, that an allowance for four weeks' unemployment and any weeks of sickness in each year was already made before an insured person was subject to any reduction of benefits for arrears under National Insurance; if the arrears exceeded this allowance, an opportunity was given to the insured person to make a comparatively trifling payment between July and November of each year in order to avoid any reduction of benefit. In these circumstances, Dr. Addison did not think it necessary to make any exceptional arrangements to meet the present distress.

Prison Medical Officers.—In answer to Mr. Stith, on February 23rd, Mr. Shortt said there were thirty-one part-time medical officers employed at the following prisons: Bedford, Bristol, Canterbury, Cardiff, Carlisle, Carmarthen, Carnarvon, Dorchester, Durham, Exeter, Gloucester, Hull, Ipswich, Leicester, Lincoln, Maidstone, Newcastle, Northallerton, Northampton, Norwich, Nottingham, Oxford, Plymouth, Portsmouth, Preston, Shepton Mallet, Shrewsbury, Swansea, Usk, Winchester, and Worcester.

Disability Pensions.—Mr. Macpherson, replying to Mr. T. A. Lewis on February 23rd, said he was not prepared to accept the suggestion that any man who, entering the army in sound health, was discharged with impaired health would have his invalidity automatically attributed to military service. Each case was considered on its merits in the light of all available evidence; and if a claim for pension was rejected by the Pensions Ministry on the ground that the disability was not due to service, the man had a right of appeal to an independent tribunal.

Farmers and the Dangerous Drugs Act.—Mr. Shortt, in answer to Lieut.-Colonel Guinness, stated, on February 28th, that he proposed to insert words in the Regulations expressly authorizing the supply of drugs for the purpose of the treatment of animals on the prescription of a veterinary surgeon. Further details as to the application of the Regulations to agriculture were under consideration in consultation with the representatives of the agricultural interest.

Tuberculous Ex-Service Men.—Dr. McDonald asked, on February 24th, if the Minister of Pensions would reconsider his attitude towards ex-service men who had been certified as suffering from tuberculosis shortly after their discharge from the army, on account of being unfit for further military service, and now considered ineligible for pension; whether he was aware that, while the health of some men was improved by service, the health of others had deteriorated, the way to tuberculosis being thus paved, and whether cases of this sort would be dealt with more sympathetically notwithstanding the decision of any medical board examining these men months after their discharge. Mr. Macpherson replied that he was not aware that claims to pension on the ground of tuberculosis were unsympathetically considered. If the tuberculosis developed within a short period of discharge the disablement was generally admitted to be either attributable to or aggravated by service, and even where the disease did not develop until after a considerable period, the circumstances of the man's military service and of its effect on his health were carefully examined. If the Ministry were unable to accept his claim the man was advised of his right to appeal to an independent tribunal.

Delay in Appeal Tribunals.—Lieut.-Colonel Sir F. Hall asked a question, on February 24th, as to delay in hearing cases before the appeal tribunals, particularly in the London region. Mr. Macpherson replied that two extra courts were now sitting, and that two more would begin sitting on February 25th. The question of further increasing these courts was now under consideration by the Lord Chancellor. He had no control over the appeal tribunal, but would approach the Lord Chancellor to see whether more courts could not be provided, as there was reason to fear that there might be an increase next month in the number of cases awaiting hearing.

The Dentists Bill.—Dr. Addison stated, on February 28th, that he was not in a position to name any particular date for the introduction of the Dentists Bill, but if there were a general desire in the House that the bill should be introduced without delay, and if it would be treated substantially as an agreed bill, the Government would be prepared to introduce it in another place at an early date.

Sinking of Hospital Ships.—The Attorney-General, in reply to Mr. Bottomley and to Sir F. Hall, stated that the list of the names of forty-five Germans accused under Article 228 of the Treaty of Peace with Germany was handed on May 7th, 1920, to the German Government. To this list the British Government contributed the following seven names: Lieutenant Commander Patzig, charged with having sunk without warning the hospital ship *Llandovery Castle*, and with having afterwards fired on and sunk the boats containing the survivors, with a consequent loss of 234 lives; Lieutenant Commander Neumann, charged with having torpedoed without warning the British hospital ship *Dover Castle* when homeward bound from the Eastern Mediterranean fully laden with sick and wounded, with a loss of six lives; Lieutenant Commander Werner, charged with having sunk the British ss. *Torrington*, and with having subsequently drowned the whole of the crew, with the exception of the master, by submerging them while they were on the deck of the submarine; and Neumann, Trienke, Müller, and Heinz, charged with acts of cruelty to prisoners of war at various prison camps in Germany. After recounting earlier steps taken, Sir Gordon Hewart said that on November 26th, 1920, a printed volume containing the complete evidence in the cases in which these persons were concerned was delivered to the German Ambassador for transmission to the Attorney-General at Leipzig. Up to the present the Government had not received information that any one of the selected cases had been brought to trial. Various technical difficulties had been raised by the German authorities, but it was in direct conflict with the facts to state, as had recently been stated, that some of the cases had been settled by agreement or otherwise. It was the intention of the British Government to enforce the trial of these criminals if they were not dealt with by the Leipzig court. Until the end of last year it was impossible to say that there had been unreasonable delay.

England and Wales.

THE EPIDEMIC OF INFECTIOUS FEVER CASES IN THE AUTUMN OF 1920.

A REPORT has been issued by the Infectious Hospitals Committee of the Metropolitan Asylums Board relative to the manner in which the autumn epidemic of infectious fever cases was dealt with. That epidemic was, from the point of view of the numbers concerned, the biggest epidemic with which the Metropolitan Asylums Board has had to deal in its history. During the epidemic of 1919-1920 it was not found possible to receive all the cases of infectious diseases for whose admission application was made, owing to the curtailment of the fever hospital accommodation during the war to meet urgent national needs. Yet only a few months later a task vastly greater in magnitude was actually accomplished with complete success, under conditions from which the war embarrassments had been largely, though not entirely, removed. In the epidemic of 1920, from the beginning of July, when the rise began, to the end of the year, when, although numbers were declining, cases were still being admitted in large numbers, the total number of cases was 23,179, as compared with 19,761 in 1907, which was the previous highest total for the same period. Cases of diphtheria numbered 7,198 in 1920 as compared with 4,145 in 1907. In view of the great difficulty experienced during the previous autumn and winter in securing the nursing staff required, an extensive and systematic advertisement campaign was instituted throughout the country, and some 860 nurses were engaged by the matrons of the different hospitals. Even this number did not satisfy the needs, and it was found necessary to employ nurses from nursing institutes to the number of 197, while at times the staff had to work overtime so that a larger number of patients could be accommodated at the various hospitals. With a view to utilizing the large resources of Joyce Green Hospital, Dartford, in the early stages of the epidemic, arrangements were made in September under which on several days in the week a number of acute scarlet-fever cases were removed from their homes to Rotherhithe, and conveyed to Long Reach by one of the Board's hospital steamers, which on its return brought back recovered patients to Rotherhithe, whence they were taken to the usual ambulance stations for discharge. When, owing to extreme pressure, it was doubtful if the beds could be provided for all cases on immediate application, special efforts were made to admit every diphtheria patient at once; these efforts were entirely successful, except on three occasions, when one or two cases were held over from one evening to the following morning. The vast majority of the scarlet-fever cases throughout the epidemic were likewise removed at once, and no case which the Board was asked to receive was refused admission. It will be realized that the unprecedented demands in connexion with this fever epidemic placed a severe strain on the administration of the hospitals and the ambulance services, and the Metropolitan Asylums Board has very rightly conveyed to the medical superintendents, matrons, and other members of the staffs an appreciation of their services.

DISTRICT NURSING IN LONDON.

The change in the economic conditions of the country brought about by the after-effects of the war has caused special attention to be given to the provision of nurses for a class of patients who do not usually seek the services of district nurses. The difficulties in the way of such patients obtaining private nurses arise from various causes. In some cases lack of accommodation makes it impossible to house a resident nurse, and this is found increasingly to be the case in flats. In other cases the economic problem is the chief one, for many patients of the professional classes are unable now to afford the ordinary fees of a private nurse. The annual report of the Central Council for District Nursing in London for the year 1920 states that efforts to meet these classes of case have so far been sporadic and unorganized. In London certain members of the Nurses' Co-operative Association have undertaken the cases of people living in flats and able to pay full fees, but unable to house a nurse; but it appears that such facilities either do not exist in sufficient number or, if they

exist, are not sufficiently known. Some district nursing associations, especially in the provinces, have endeavoured to meet this need, and most of them agree to allow their nurses to visit patients who can make some small payment, usually in the form of a donation. In London this plan has not been largely followed, though several of the associations are now considering the propriety of doing so. It appears clear that services rendered by district nursing associations should be limited to those who cannot pay the fees necessary to put the scheme on a profit-earning basis. A memorandum on the subject has therefore been issued by the Central Council to the Nurses' Co-operative Association and to the District Nursing Associations. The opportunities and the interests offered by district work are necessarily limited in their appeal to nurses, since with that work must also go considerable hardships, needing devotion and self-denial. The District Nursing Associations, while demanding the highest qualifications for their nurses, are unable to offer very attractive salaries; the minimum salary payable to district nurses by associations in receipt of grants has been increased from £50 to £63 over and above board and lodging; and this matter will probably have to be reconsidered in the near future. Even the full three years' training in a general hospital is not considered sufficient to fit a nurse for work calling for resources so varied as that of a district nurse, carried on, as it is, in conditions so different from those prevailing in a hospital, and often needing considerable knowledge of social work in all its many forms as well as practical skill. The district nurse has a share in all the health work of a district, including infant welfare and tuberculosis. Even with the increased grants made possible during last year, several of the associations are finding it necessary to curtail their work and to withdraw nurses. In view of the fact that every effort is being made to cover the districts unprovided with nurses, it is regrettable that such curtailment should be necessary, and a suitable appeal to the public will shortly be put forward in order that the voluntary associations may be adequately maintained. The annual meeting of the Central Council for District Nursing in London was held at the offices of the Metropolitan Asylums Board on February 28th, when it was decided that the executive committee should inquire as to the adequacy and efficiency of the provision of district nursing in the County of London, with a view to systematizing and improving the arrangements, and the desirability of extending the work beyond the area of the county. A report on the subject will be made to the Central Council.

Scotland.

ROYAL MEDICAL SOCIETY.

THE annual dinner of the Royal Medical Society, the first dinner of the Society since the war, was held in the Hall of the Royal College of Surgeons, Edinburgh, and was attended by a large and distinguished assembly. Dr. J. Davidson, senior president of the Society, was in the chair, and the guest of the evening was Professor Robert Muir, M.D., F.R.C.P., of Glasgow University, an old member of the Society. The toast of "The Imperial Forces" was proposed by the Lord Provost of Edinburgh and replied to by Admiral Sir Herbert Heath and General Sir Francis Davies. The toast of "The Guest" was proposed by the Chairman, and Professor Robert Muir, in reply, thanked the Society for having honoured him. Professor Muir then proposed the health of "The Royal Medical Society," giving reminiscences of his student days as a member of the Society. He sketched the history of the Royal Medical Society from its foundation in 1737, pointing out that even at an early period it came to regard itself as an essential part of the medical school, not of the University, nor of the Royal Colleges of Surgeons or Physicians, but of the Edinburgh Medical School as a whole. It had had considerable influence in making old quarrels disappear and in the development of the feeling that the medical school was a common cause. Dr. J. Lewis Owen replied to the toast. Dr. J. M. Watt proposed the toast of "The University and Royal Colleges," responded to by Principal Sir Alfred Ewing, Sir Robert Philip, Dr. George Mackay, and Dr. Freeland Fergus of Glasgow. Dr. J. F. C.

Haslam proposed the toast of "Sister Professions," to which the Rev. Dr. Wallace Williamson and the Solicitor-General for Scotland replied.

GLASGOW MATERNITY HOSPITAL.

A serious position is facing the Glasgow Royal Maternity Hospital, and at the annual meeting on February 25th the main topic of discussion was the financial embarrassment of the past year. In the course of 1920 the state of indebtedness of the hospital to the bank reached a point which compelled the directors to consider the serious question as to whether the hospital should not be closed. The directors put the position before the Board of Health for Scotland, and a conference was held at which representatives from the hospital, the local authority, and the university attended. It was subsequently decided that the ante-natal wards and dispensaries should be closed on January 31st, 1921. A payment of £5,000 to account of the cost of the treatment of indoor ante-natal cases made by the local authority on January 27th enabled the directors to suspend their resolution to close these wards and dispensaries for the time being, but that relief is only temporary.

Ireland.

CENTRAL MIDWIVES BOARD FOR IRELAND.

THE Central Midwives Board for Ireland held a meeting at the office of the Ministry of Health, 33, St. Stephen's Green, Dublin, on February 24th. There were present Sir E. Coey Bigger (in the chair), Sir A. J. Horne, Sir W. J. Smyly, Dr. Charles G. Lowry, Miss J. H. Kelly, Miss Michie, Professor Corby. The Chairman referred in feeling terms to the death since their last meeting of one of their members, Alderman J. C. McWalter, M.D. He proposed a resolution expressing the sense of the loss which the Board has sustained, and conveying to Mrs. McWalter and family the Board's deep sympathy with them in their sad bereavement. The resolution was unanimously adopted.

The secretary reported that at the examination held in Dublin, Belfast, and Cork simultaneously on February 8th and 9th, 63 candidates presented themselves, of whom 61 passed and were granted certificates. The total number on the Midwives Roll of Ireland is now 2,902. A special meeting of the Board was subsequently held to consider the following charges preferred against one of the midwives on the roll: (1) That, being in attendance at a confinement, she failed to take the necessary steps to secure the attendance of a registered medical practitioner, the case being one which required such attendance. (2) That she failed to hand to the husband or nearest relative the form for sending for medical assistance. (3) That she failed to keep any record of the pulse or to keep a correct record of the temperature of the patient at each visit. The Board, after hearing the evidence in support of the charges, and considering a statement furnished by the accused, decided that her name should be removed from the Midwives Roll.

Correspondence.

THE COLLECTIVE OPINION OF THE PROFESSION.

SIR,—In the SUPPLEMENT, February 19th, page 42, appears a Memorandum advising the profession that, on the direct request of the Minister of Health, dated November 26th, 1920, the British Medical Association is endeavouring to form a committee of medical practitioners which shall be able to state that it voices the collective opinion of our profession centrally.

This Memorandum is admirable, in that it clears away once for all a great amount of mist and doubt often deliberately brought about by enemies of our profession. If the Minister, as Dr. Gordon Ward more than suggests, has stated to any other medical body that, unless it is called into collaboration in this matter by the Association, he will not recognize the resultant committee, such communication should be published at once and be dealt with. It

is not an action of interference and prejudging the issue which those acquainted with the present Minister would credit him with.

This opportunity offered by the Minister to the profession, both for its union and through that union for the benefit of the community at large, is so immense that it is profoundly to be hoped that, through jealousies or otherwise, it will not let it slip away and once more show to the world that it is an impossible crowd of individualists—incapable of give and-take, with no imagination—which can well be ignored.

Now the body ultimately formed should be such as will fulfil at least these conditions:

1. The Minister of Health, whoever he may be, must be absolutely satisfied that the body is supported by a great majority of the members of the medical profession in active practice, and that in refusing to recognize any other groupings he is not thereby depriving any of their opportunities for being heard.

2. The proposed body itself must be satisfied that every practitioner in active practice has been given an opportunity of expressing an opinion on its constitution and mandate, and in consequence has been allowed his (or her) due weight in its formation.

3. Every such registered medical practitioner should have had a similar opportunity of satisfying himself.

4. The enemies of the profession within its ranks (whether a society or individuals) must once for all have been deprived of all evidence in support of a possible contention that the majority of the members of the profession in active practice are not supporting such a body.

5. The proposed body must be able to show irrefutably that after negotiating with the Minister it is able to "deliver the goods."

If these conditions are generally approved then it would seem to follow that recognition has been obtained for the necessity of consulting all the members of the medical profession in practice within the United Kingdom, if the proposed body is to receive from the commencement that cordial recognition and support without which it cannot satisfactorily fulfil its aims and objects. For this purpose, therefore, one would advocate that there should be issued promptly, to every such practitioner, with a copy of the memorandum as it appears in the SUPPLEMENT, a questionnaire containing certain principles suggested by this memorandum. The inquiries would seem to be—

A. Are you at present in active practice in the medical profession?

B. Do you approve generally of the memorandum sent you herewith?

C. Do you consider that the proposed medical body

(1) Should represent the views of the medical profession and the medical profession alone?

(2) Should be an immediately and directly responsible body recognizing the authority of its constituents and no other authority?

(3) Should, in its formation, be confined to those constituents directly and intimately concerned in medical politics and trained in expressing opinions on such matters?

(4) Should not profess to promote the interests of the community rather than those of the medical practitioners engaged in active practice?

D. Do you approve of the proposed body being formed of representatives of

The Royal College of Physicians of London.

The Royal College of Surgeons of England.

The British Medical Association.

The Society of Medical Officers of Health.

The Medical Women's Federation.

The Poor Law Medical Officers' Association.

The Medico-Psychological Association.

The Association of Certifying Factory Surgeons.

E. If not, what other medical bodies intimately concerned in medical politics should be asked to become associated with those mentioned in D above?

F. Do you consider that it would be sufficient if this body (formed as in D above) should recognize other medical bodies concerned in medical politics by consultation and co-operation when necessary and desirable?

Looking at these questions, the only comments one would venture to make at this juncture are: (a) That if an affirmative majority reply is received to query C (1), it rules out of court the Federation of Medical and Allied Societies, which is a body with a preponderating number of represented lay persons. (b) That if an affirmative majority reply is received to query C (3), it rules out of court the Royal Society of Medicine and other numerous scientific medical and dental societies which have no acquaintance with medical politics and are attached to the Federation of Medical and Allied Societies. (c) That

those who considered that the list given in query D should be extended have the opportunity offered by propaganda to obtain their wishes by securing replies to query E.

If the profession replied in the affirmative to queries C (1), C (2), C (3), C (4), and added the Medico Political Union and the National Medical Union when replying to query E, one would have great hopes for the future. (That the societies referred to in query D should not co-operate would be a calamity.) Both these additional bodies, like the British Medical Association, have refused to have anything to do with joining the Federation, and sweet reasonableness now on all sides might be expected to result in future useful co-operation between them and the Association.

Might it therefore be urged that all medical societies concerned in medical politics, all Local Medical and Panel Committees, and all Branch Councils and Division executive committees, as well as individuals, should at once consider this memorandum, and demand of the Association as a first step that every registered medical practitioner now engaged in active practice be given an opportunity of expressing an opinion on the questions at issue, not delaying until it is found to be too late to make their voices effectively heard. In the meanwhile, would the committee of the Council which has the matter in hand refrain from taking any action which might jeopardize the position?—I am, etc.,

Hove, Feb. 26th.

E. ROWLAND FOTHERGILL.

SOUTH AFRICA AND THE BRITISH MEDICAL ASSOCIATION.

SIR,—On a recent visit to South Africa, just following Dr. Macdonald's most successful tour, I was much impressed by the high spirit of loyalty displayed by the profession there to the British Medical Association, and by the strong desire expressed, even by the Dutch members, that a closer union, if that were possible, should exist between the South African Branches and the Home Association.

The local disruption in the Transvaal is, in the opinion of those most competent to judge, confined to a small area, consists of a few malcontents, is only temporary in character, and will, in all probability, soon fizzle out—the action of the recent Medical Congress to defer a decision for another year giving the movement time to expire gracefully.

The Association in South Africa is very much alive, and, while determined upon obtaining greater powers of self-government, it remains loyal to the parent Association.

The reception given to the Association's representative, Dr. Macdonald, was great, and must have been gratifying alike to him and the Council. If the Association desires to retain the Colonial Branches by their loyalty, then the policy of sending out representatives from time to time must be the future policy of the Association, and thus we shall establish an Empire Medical Association, whose Branches will be found wherever the dear old flag flies.—I am, etc.,

Foråingbridge, Feb. 26th.

T. DUNCAN GREENLEES.

ENDEMICITY OF INTESTINAL PROTOZOA.

SIR,—May I be allowed a few words with reference to your interesting leading article of February 19th upon the subject of the endemicity of human intestinal protozoa?

We have, broadly speaking, the fact that *Entamoeba histolytica* (restricting ourselves for the moment to this pathogenic form) gives rise in this country only very rarely to amoebic dysentery, whereas in many tropical and subtropical districts this disease is prevalent. In England, as in those countries, a certain proportion of the population is known to be infected with the parasite, occurring in the "carrier" phase. The question is, what is the explanation of the marked difference of behaviour of the parasite in the two cases?

I myself have for some time considered that the chief reason therefor may be found in a different "normal" intestinal flora in this country, for instance, from that common in countries where amoebic dysentery is of frequent occurrence. To give an example of what I mean. There is a well known transient complaint, which was alluded to by our men as "gippy tummy," characterized by sickness and diarrhoea, to which many are liable on

first arriving in Egypt, however careful they may be as regards what is eaten and drunk. Such an attack is probably in consequence of some change in the intestinal bacteria, with resulting disturbance until the alimentary canal has become accustomed to this new factor. And it is well known how careful, in general, one must be to avoid gastro-intestinal disturbance on going to a tropical or subtropical country.

Now we know really very little concerning the extent to which some bacterial infection stands in relation with or helps to induce amoebic dysentery. I have previously emphasized (*Journal of the Royal Army Medical Corps*, vol. xxix, 1917, p. 299) that "for the amoeba to give rise to dysentery there must be some lesion or derangement of the bowel—at least, some non-normal condition—lowering its resistance and giving the amoeba its opportunity." And "precisely the same reasoning applies to the intestinal flagellates." I would suggest, therefore, that the primary factor which either lowers the resistance of the bowel, or enables the amoeba to take advantage of a lowered resistance—the result being an attack of amoebic dysentery—is some bacterial infection. Indeed, this suggestion, that a bacterial infection may produce amoebic dysentery in the case where a man is already infected with the amoeba, has been made by Thomson and Mackie (*Journal of the Royal Army Medical Corps*, vol. xxviii, 1917, p. 409).

I do not consider that the suggestions, either of a non-pathogenic strain of *E. histolytica* in this country or of acquired immunity on the part of the population, will account adequately for the difference above noted. In the first place, amoebic dysentery is now known to occur—if very rarely—in people who have never been out of Britain. And I think the following point is of considerable significance: Not only before the war were a certain number of people doubtless infected with what would be regarded as the pathogenic strain arriving regularly in this country, but during the war vast numbers of troops so infected arrived home. And there can be no doubt, further, that a certain number of people who had never been abroad—especially, for instance, recruits—came into contact with such "carriers" and became themselves infected from the carriers' cysts. Yet how many cases of amoebic dysentery have resulted from infection so acquired, not only during recent years, but through all the years since intercourse with the East became general? Very, very few, certainly. But compare, on the other hand, the difference as soon as our troops went East and came into contact with Indian or Egyptian native sources of infection.

The conclusion is forced upon us, I think, that there is some additional, as yet unknown, factor concerned, operating in countries where amoebic dysentery is prevalent, which is not usually operative in this country and others where amoebic dysentery is of rare occurrence. To some extent this factor may be perhaps climatic. But I think, in the main, it is quite likely to be the predisposing harmful influence exerted on the bowel by some bacterial infection to which dwellers in this country are not normally or to nearly the same extent exposed as are those in districts where amoebic dysentery happens to be endemic. It is perhaps not without significance that amoebic dysentery does occur, apparently to a slight extent, among patients in lunatic asylums, where bacillary dysentery is far from uncommon, and where the general bacterial condition and resistance of the bowel may be, for some reason, not what we in this country are accustomed to regard as normal. Again, it may be suggested that "ulcerative colitis," of bacterial origin, may be the cause of the appearance of symptoms of amoebic dysentery in patients who are "carriers" of this amoeba.—I am, etc.,

The Lister Institute, Feb. 22nd.

H. M. WOODCOCK.

SIR,—Mr. Clifford Dobell's report on the intestinal protozoa endemic in Britain and your editorial comments on the same (p. 276) have interested me as I have recently examined for protozoa the faeces of 120 children admitted consecutively to one ward of this hospital. In this series *Jambliia intestinalis* was present in seven cases, of whom the youngest was only three months old. Of these children four were admitted for diarrhoea. In one case this symptom had recurred at intervals for six years, and had led to a slight degree of impairment of growth. To what extent this flagellate can be held to be responsible for the

diarrhoea in these children it is at present impossible to say, but it appeared to be the only factor in the production of this symptom in the protracted case mentioned, for careful clinical and pathological observations excluded as far as possible all other causes of diarrhoea.—I am, etc.,

HERBERT PERKINS,

Pathologist, Paddington Green Children's Hospital, W.

February 22nd.

THE CURE OF HAEMORRHOIDS WITHOUT OPERATION.

SIR,—I am in cordial agreement with the main thesis of Dr. Lyth's article upon this subject in the *JOURNAL* of February 19th, that the operation for haemorrhoids is not always successful, is usually unnecessary, and is rarely justifiable. The late Sir James Goodhart wrote to the same effect in the *Practitioner* of December, 1914, and his article led to a series of others by various rectal and general surgeons, printed in the *Practitioner* of March, 1915. Stimulated by these articles, I tried various treatments for haemorrhoids at St. Mark's Hospital, where I was temporary assistant surgeon at that time, and in the *Lancet* of March 18th, 1916, I published a paper on the treatment of haemorrhoids by injection. Since 1914 I have been practising this method of treatment very extensively, and have every reason to be pleased with the results I have obtained.

Whilst agreeing with Dr. Lyth's opening text, I cannot at all agree with his description of the pathology and course of haemorrhoids. Let me at once correct him in his idea that when an internal pile has prolapsed it has become an external pile, in any other sense than that it is now outside the sphincter ani. Internal piles are attached to the mucous membrane of the rectum above the anal valves, and are always covered by mucous membrane and never by skin; they can always be reduced completely into the bowel, unless strangulated. They are essentially different from external haemorrhoids. External haemorrhoids are of two varieties:

(1) Thrombosed external haemorrhoids, which are inflamed thrombosed subcutaneous varicose veins, and appear as hemispherical, purplish lumps, covered with ordinary skin, and varying in size from that of a pea to that of a walnut. If left alone or treated "palliatively" they subside in two or three weeks, but meanwhile cause considerable pain and discomfort, and may suppurate and cause an anal fistula. They are best treated at once by snipping off about two-thirds of their bulk with scissors and forceps, and turning out the contained clot with a spoon. This little operation can be done painlessly under local anaesthesia, gives immediate relief, and leaves a wound which is usually soundly healed in a week.

(2) The other variety of external haemorrhoid is the ordinary "skin-tag," which is a peniculous fold of skin growing from the anal margin. Skin-tags as a rule give rise to no symptom other than slight itching, unless they become inflamed or infected, when they can be removed under a local anaesthetic.

Dr. Lyth boldly states that as long as an internal pile remains inside the anus it does little harm. But it is a daily experience of those who see many rectal cases to meet with patients who have piles which have never prolapsed, but who nevertheless have had such frequently repeated haemorrhage that they have been rendered extremely anaemic. I have twice been summoned to see patients who have had such alarming haemorrhage from piles that have never prolapsed that they have been rendered pulseless and almost at death's door. Other exceedingly common symptoms of piles which have never prolapsed are pruritus, pain, discharge of mucus, dyschezia, etc. Without a good rectal speculum (such as Kolly's proctoscope) a pile inside the anus cannot be diagnosed, except by guesswork, because even the largest internal haemorrhoids, if uncomplicated, cannot be felt even by the finger endowed with the most highly developed *tactus eruditus*. Even comparatively small internal haemorrhoids frequently cause quite severe haemorrhage and other troublesome symptoms.

Dr. Lyth's treatment by the frequent application of calamine powder and the constant application of a pad to the anus may have its uses, but I doubt whether it is likely to control haemorrhage from piles of any size, and it is obviously inapplicable to piles which are not prolapsed. On his own showing, if the piles are prolapsed, it will be some six weeks before spontaneous reduction can be achieved even by the patient's adoption of the recumbent posture after defaecation; and even then the patient is only

"in a fair way to being cured." Meanwhile, and even afterwards, he has to wear a pad, to powder his piles frequently, to ensure that his bowels only act at bedtime, and so on.

By means of injections about 90 per cent. of all cases of internal piles can be treated painlessly without operation, and without lying up a single day. In the very large majority of the cases I have treated—which amount to many hundreds—both bleeding and prolapse have disappeared from the moment of the first injection, and in all cases a permanent disappearance of the piles may be looked for after from three to six injections.

Method.

The piles are injected *in situ* through a Kelly's speculum by means of a suitable syringe. The syringe I recommend is a modification of Dawson's dental syringe, which is long enough to use through the speculum. It is stocked by Messrs. Krohne and Sesemann, Messrs. Allen and Hanburys, and others. The solution I use consists of 20 per cent. carbolic in equal parts of glycerin and water. About 5 minims of this solution is injected into each pile in such a way that the fluid is lodged near the centre of each pile. In the case of a very large pile a few more drops may be injected into its base. A few seconds after injection the pile swells considerably, and its surface turns white. The needle should be kept in position until these changes have been observed, because otherwise some oozing is likely to occur and the fluid will be washed out with the blood. All the piles may be injected at one sitting. Care must be taken to inject too little rather than too much of the solution, because if too much is used there will be a more violent reaction and considerable pain may result. If the correct amount and the right strength of solution is used, there is not usually any pain worth mentioning. The patient must be warned that in the unlikely event of his piles coming down after injection, he must not delay in washing them with cold water, greasing them with vaseline or any ointment, and gently returning them. If this is not done, and the piles happen to come down after injection, they may continue to swell outside the anus and become strangulated. Apart from this, no treatment other than a laxative is required. The injections are repeated at weekly intervals, until examination with the speculum shows no pile present.

I have recently written to all my private patients whom I treated by injections upwards of three years ago. Of those from whom I received answers to my questions I find that 83.4 per cent. report themselves absolutely free from all rectal symptoms. Of the remaining 16.6 per cent. by no means all have any real trouble, because I have included amongst them such cases as those in which the patients have "occasional itching about the anus," "occasional uneasiness," and so on. Amongst this 16.6 per cent., as well as amongst the 83.4 per cent. absolute successes, were several in which I did not advise injection at all, because I found complications which rendered operation the preferable treatment; however, I injected them at their own earnest request, and even in those who are not still well there was a long interval of complete comfort.

This treatment is so simple that any practitioner who will acquire the few necessary instruments and a certain amount of practice may adopt it. But before doing so he must have a clear idea of the difference between external and internal piles, because the method is quite unsuitable for the former and, if employed therein, might lead to very unpleasant results.

I fancy most patients would prefer this treatment, with its practically instantaneous relief, to the treatment suggested by Dr. Lyth, which takes six weeks of messy and tiresome applications to obtain even partial relief and, I venture to assert, almost certain recurrence sooner or later.

Obviously most patients will prefer it to operation, which involves two weeks at least in a nursing home, much expense, a general anaesthetic, and not negligible pain, and which, in my experience (of patients operated on by others as well as by myself), gives no better results as far as recurrence of symptoms is concerned.—I am, etc.,

London, W.C., Feb. 25rd. ARTHUR S. MORLEY, F.R.C.S.

SIR,—It is the duty of all good physicians in these days to protect their patients from the "tyranny" of the surgeon, and consequently the article by Dr. Lyth (February 19th, p. 265) on "the cure of piles without operation" will be of interest to many of us.

As one of those who are of opinion that surgery should be looked upon in many cases as a last resort only, I cannot agree with Dr. Lyth that that view should be pressed too

far when dealing with that most painful of minor affections—haemorrhoids.

No class of case causing the prolonged suffering which is characteristic of inflamed piles responds so swiftly and with such triumphant success to the ministrations of the surgeon.

Meanwhile one is moved to sorrow, if not to a certain amount of unseemly hilarity, at the thought of Dr. Lyth struggling with a mass of acutely inflamed external piles which obstinately refuse to be returned to what he insists must be their proper home within the sphincter. I fear that such intervention could only result in unmerited suffering for the unfortunate patient and great satisfaction in the camp of the enemy who will be called in to repair the mischief.—I am, etc.,

HOVE, Feb. 21st. A. H. COPEMAN, M.D.

RISKS AFTER OPERATIONS ON TONSILS AND ADENOIDS IN OUTDOOR CLINICS.

SIR,—I should like to suggest that the dangers and complications of the tonsil and adenoid operation when performed in the out-patient department are not so serious nor so numerous as the letters of previous correspondents might lead one to suppose.

At all the hospitals in London of necessity hundreds of these operations are performed each year, conferring great benefit on the patients. I am, of course, only able to quote figures from my own department, but no doubt statistics from other hospitals would show equally favourable results.

Through the kindness and energy of the London County Council "Assistant Organizer" at Guy's I am able to give the following statistics from all the London County Council school children operated on during the last three years in the out-patient department:

The total number of operations was 2,039; the following complications occurred:

Haemorrhage necessitating admission for two or three nights	2 cases
Haemorrhage after returning home for which a doctor was called in	1 case
Otorrhoea coming on within one week of operation	2 cases
Otorrhoea coming on one month after operation	1 case
These cleared up in less than a fortnight.	
Illness at home and a doctor called in	2 cases
Admitted to the hospital one week after operation on account of vomiting	1 case

In one case Vincent's angina developed in the tonsil bed, in two cases temporary otiticis followed operation, but it is most improbable that these can be ascribed to the fact of the patient's return home after operation.

Expressed in percentages: Haemorrhage occurred in 0.147 per cent., otorrhoea in 0.147 per cent.

Though I have no actual statistics, I can state that amongst some 8,000 operations performed in the out-patient department during the last ten years no death has occurred, though one case was only saved by cardiac massage; nor has there been any case of acute otitis media that progressed to acute mastoiditis.—I am, etc.,

LONDON, W., Feb. 28th. W. M. MOLLISON.

THE IMMUNIZING EFFECT OF X RAYS IN CANCER.

SIR,—The correspondence with regard to x rays in the treatment of cancer which has appeared in your columns of late cannot fail to be of interest to the medical profession in general. Dr. Morton is the advocate of penetration and yet more penetration. The harder the ray, the greater the electronic disturbance within the tissues; this, of course, is true, and it is also true that if we seek to destroy a malignant growth by direct attack, x rays must reach it in large quantities. But neither quantity nor quality in themselves guarantee success. The gamma rays of radium may fail even in the case of readily accessible tumours, and this although a relatively enormous amount of this agent may have been available. Then the average hardness of the x-ray beam used in therapy has been double and trebled within the past ten years; yet will anyone assert that the prognosis of cancer in bone—even thin superficial bone—has been sensibly improved? The ideal of the *therapia sterilans magna* has never yet been reached in medicine. Ehrlich believed he had attained it, but there is now reason to think that salvarsan acts indirectly by stimulating the tissues, as well as by direct poisoning of the spirochaete. The x ray does not destroy cancer *in vivo*

wholly—probably not even chiefly—by an immediate destructive action upon the cancer cell, but by local and general stimulation of the protective mechanisms of the body. Laboratory investigations as to the effects of varying doses of x rays upon cancer masses *detached from their natural surroundings* cannot therefore be in any way relied on to forecast the results of similar doses applied to the living patient.

Experiments designed to raise or lower the immunity of an animal are, of course, in a different category. It has been shown at the Rockefeller Institute in America, and confirmed by Professor Sidney Russ and others in this country, that a single large dose diminishes resistance to cancerous invasion; whereas a series of carefully graduated small doses raises resistance to such an extent that it is almost impossible to get a cancer graft to "take." Whether the rays from a tube "backing up" a 16-inch gap are more effective as resistance-raising agents than those from a tube "backing up" only 10 inches remains to be proved.

The Erlangen procedure, whatever it does to the primary growth, must lower the general resistance, at any rate for a time, thus actually helping any existing metastasis to spread, and likewise any projection of the tumour which may have escaped irradiation. It also produces some skin reaction. The method must stand or fall by itself; it cannot safely be combined with operation. After such dosage he would be a bold man who would submit the skin and subjacent parts to surgical trauma; while as a post-operative procedure it is difficult to see how it can have any *raison d'être*.

Now the tendency at present, in this country, is to seek to combine x -ray treatment with surgery. That this can be successfully done, both before and after operation, can be testified by many, including myself. But the large single dose must be eschewed. Dr. Morton tells us that small doses stimulate a malignant growth. Perhaps a single small dose does; I have no experience. But it is certain that seven or eight comparatively small doses, from a Coolidge tube having a 10-inch spark gap, if spread over a period of about three weeks, will cause a palpable diminution in a carcinoma of the breast, and not in any way interfere with the surgeon's work. A 3-millimetre filter is used, the anti-cathode skin distance is one foot, and the patient is not shielded except as to the face. The current in the secondary is 1.5 milliamperes and the time fifteen minutes.

The action I do not believe to be primarily a local one. In my opinion the treatment acts much as a course of vaccines—it raises the resistance of the patient to cancerous invasion, and places him in a favourable condition for the operation. As to post-operative treatment, the same idea is carried out. Courses of a dozen to eighteen sittings are given at intervals varying from three months to a year, the object being not to kill off any remaining cancer cells by the direct effect of the rays, but to put the body in a condition to combat their growth. That a series of small doses has this effect in animals was proved in the same set of experiments which showed the harmful effect upon the body resistance of large single doses. It will be noted that this system permits of actually shielding the growth itself from the x rays should this be considered desirable.

The results quoted by Dr. Reginald Morton as having been attained at the Erlangen clinic are not wholly convincing—as yet. The number of cases is small, and the observations extend for an average of about three years only. Taken at their face value, they are decidedly better than those obtainable by surgery alone, more especially as regards uterine cancer. Figures for cases treated by a combination of x rays and surgery, with pre- and post-operative raying, are not yet available to any great extent in this country, but there is no doubt but that they show an improvement on surgery alone.

It may be that, at no very distant date, uterine and breast cancer will be treated by x rays alone; but, even then, it does not follow that the Erlangen technique is the only one by which cures can be accomplished, or that there is no apparatus in Great Britain suitable for the purpose. It must be remembered that, so far, British radiologists have had practically no opportunities of finding out what can be accomplished entirely apart from operation, for the latter has been the rule.

British x -ray workers will, I am sure, hesitate long before adopting the heavy dosage advocated in Germany. They remember the skin disasters which were beginning to

come to light just before the war as a result of big doses, although the skin had not at the time appeared to be injured; and if in the near future they are called upon to treat cancer apart from surgery, they are likely in the first place to try out less drastic procedures. To condemn the Erlangen technique would be foolish; it is a serious attempt to substitute x -ray irradiation for surgical operation in the treatment of cancer of the breast and uterus, and it may be successful; but, in the nature of things, the proof or disproof will occupy many years.

Meanwhile, any attempt to secure the wholesale adoption of the method in this country is to be deprecated. I have already had medical men writing to me to ask if I am sure my doses are big enough—if I am certain that I am not stimulating instead of depressing. Such is the effect of a single letter from a man of Dr. Morton's eminence.

Let us clearly understand that the Erlangen technique has not been designed for use in conjunction with surgery, whereas the attempt to "immunize" the patient by comparatively small doses is based on the results of animal experiments, makes surgical operation more easy, and is without risk of sudden catastrophe. So far it is justified by clinical results, and it is at least worth some years' systematic trial.

The use of x rays as immunizing agents in cancer was fully discussed by me in a paper in the BRITISH MEDICAL JOURNAL for June 12th, 1920. The immunity is not specific; it is effective in tubercle, Graves's disease, and other conditions. The conception of x rays as resistance-raising agents, rather than substitutes for local surgery, is likely to help much towards that close combination between surgeons and radiologists which is so greatly to be desired.—I am, etc.,

London, W., Feb. 14th.

F. HERNAMAN-JOHNSON.

CONFERENCE OF STAFFS OF VOLUNTARY HOSPITALS.

SIR,—I observe that the Leicester motion, which I vainly attempted to oppose at the London Conference, and against which I protested strongly in a letter to the JOURNAL immediately afterwards (January 1st, 1921, p. 31), has been rejected by the Conference in Scotland in favour of one considerably more modest even than that which I put forward myself as an alternative. I trust that the Leicester motion may now be dropped altogether. Rarely indeed has a resolution so detrimental to the voluntary system been propounded, even by its worst enemies. Had the Representatives in London first discussed it with their own lay committees, and had the Chairman refrained from giving that very strong lead which he did, I am persuaded that the ill-considered motion of Leicester would have received in London the same reception that it has now deservedly encountered in Scotland.—I am, etc.,

Chichester, Feb. 27th.

G. C. GARRATT.

THE POSITION OF ARMS IN BREECH WITH EXTENDED LEGS.

SIR,—The gain to obstetrics from Dr. Victor Bonney's letter of February 16th, in your issue of February 28th, will be specially recognized: it signifies careful clinical obstetrics; it marks the value of museum evidence which, to some of us, brings its daily lesson.

The paper by Dr. W. S. A. Griffith and the late Dr. Arnold W. W. Lea on breech presentation with extended legs, in the Obstetrical Society's *Transactions*, 1897, brought the best of clinical information.

Since that time I have collected relative museum material. Some of the material, the undisturbed foetus with extended legs at four and a half months within the intact amnion and chorion, and at seven months within the uterus, both confirm Dr. Victor Bonney's description of the extended arms, only partial however, and confined to the lower hemisphere of the head, amounting to this—that if the vertex presented the foot and the hand would be palpable at the periphery of the head.

Eight years ago, after discussing this fact with Sir Francis Champneys, I was supplied by him with the notes of one of his forceps deliveries in August, 1882, embodying these anatomical facts, which so often escape published description and, probably nearly as often, clinical observation. At that time it was my wish to

have the opportunity of displaying what is now well, if not widely, understood in teaching schools. Of late years the cost of illustration has been prohibitive.—I am, etc.,

HENRY BRIGGS.

Department of Obstetrics and Gynaecology,
University of Liverpool, March 1st.

SIR,—As the medical man unsuccessfully sued for negligence whose experience Mr. Victor Bonney refers to in his letter (February 26th, p. 320) may I mention the following facts?

The case I had to conduct was one of delayed descent with the os dilated. Under chloroform I introduced my hand, and found a breech with fully extended legs (sacro-posterior breech not engaged). Passing my hand above the knee to flex and coax down the leg, I felt a displaced arm passing upward, and at once thought "if I leave that I shall get extended arm when the legs are born," so I followed the arm and found that hand lying flat on the parietal bone. Then I sought the other arm, and found it also displaced upward, elbow forward, forearm above ear, and hand under occiput; I first replaced both arms, then pulled down both legs, the child being large, turning axially at the same time, and delivered without difficulty, the arms coming out in the natural position as replaced.

I have always doubted the truth of the textbook teaching that extension of arms in a breech case can be caused in any way if the arms are in the natural folded position while *in utero*. I believe that in all cases of extended arms there must be some precedent unusual position of the arms; this belief makes it more, not less, important to verify the position of the arms as soon as the umbilicus appears in a breech case. It may mean we ought to verify their position still earlier in labour.

Having in this case lighted on some evidence in support of my belief, I wrote to seven eminent gynaecologists suggesting faulty position of arms *in utero* as the true and main cause of arm extension, and asking if they had ever had occasion to discover the position of the arms *in utero* in a case which subsequently showed extended arms.

One replied that he had sometimes found arms displaced much as I describe; none of them agreed with my theory, but none of them had a case in which, after examination had shown the arms in normal position, the arms subsequently became extended. I suppose they would say because they never pulled unduly, but I suggest that undue pulling will only be followed by extension of arms if the arms are so abnormally placed that extension would occur without undue pulling, or possibly if the pulling is so vigorous that it sets up a reflex causing the child to displace its arms before they reach the brim.

Mr. Bonney now suggests that in every case of extended legs the arms are abnormally placed. I recently had a case of a very small child born alive with ease and with extended legs unreduced (I was called late), in which the arms were normally placed. This does not affect the wisdom of Mr. Bonney's suggestion that in all cases of extended legs the position of the arms should be ascertained, and, if misplaced, replaced. The question in my mind is whether we ought not to go further, and ascertain arm position in every breech case which we see early enough to make so doing easy. I have never yet seen any trouble follow the introduction of my hand into the uterus, and children are lost from arm extension. I think it is debatable. Can any reader record a case of arm extension in a breech case in which he had previously proved the position of the arms to be normal, or subsequent extension in a case where he had replaced misplaced arms? I admit that negative evidence cannot prove my theory, but I maintain it until positive evidence disproves it. I suppose every experienced practitioner has seen cases of arm extension in which no unwise pulling was indulged in, and it is really time that the school theory that such pulling is the main cause of arm extension was given up.—I am, etc.,

Finchley, Feb. 25 h.

T. H. GODFREY.

THE DROOPING SHOULDER SIGN OF PHTHISIS.

SIR,—In my book, *Tuberculin in the Diagnosis and Treatment of Tuberculosis*, one reads on p. 72, line 16, these words: "This 'habitus phthisicus' manifests itself in the thin, weakly, weedy, long, lanky individual with stooping gait and drooping shoulders, a narrow flat chest, wide oblique intercostal spaces, moving but little (paralytic

chest), and wing-like shoulder blades projecting outwards." Certainly Dr. Rivers has not read my book. Comment is unnecessary.—I am, etc.,

W. CAMAC WILKINSON, M.D., Lond.,

London, Feb. 15th.

F.R.C.P.

SIMPLE GOITRE IN SCHOOL CHILDREN.

SIR,—When examining school children in Hampshire I have been struck by the large number of cases of slight enlargement of the thyroid occurring in both boys and girls below the age of puberty. This condition would appear to be much more common in this country than is generally supposed. The thyroid as a rule is not conspicuous, and is seen only if specially looked for. The children are perfectly healthy and robust, but upon comparing their size and weight with those of other children of a similar age, it will be found that they are almost invariably below the average. The condition consequently is not easy to detect unless a number of children of the same age are being examined at once.

Such children are never brought to a doctor for treatment, as they are not ill. The parents frequently do not realize that the child is small for its age, or if so, it is put down as a family peculiarity. I have had no opportunity of treating such children, but should they come under medical treatment for some other condition, it would be well worth while putting them on a course of thyroid or iodide, as was done in the South of France, in the hope of improving their growth.—I am, etc.,

WILLIAM A. LETHAM, M.C., M.D., D.P.H.,

Assistant M.O.H. County of Hampshire.

Brockenhurst, Feb. 27th.

Obituary.

ERNEST COURTNEY LOMAS, C.B., D.S.O.,

Surgeon Captain R.N.

SURGEON CAPTAIN ERNEST COURTNEY LOMAS, R.N.(ret.), died at Pencaitland, East Lothian, on February 24th. He was born on December 24th, 1864, and educated at Owens College, Manchester; he graduated M.B. and Ch.B. of Victoria University in 1888, and took the M.R.C.S. in that year and the F.R.C.S. in 1907. After filling the posts of house-surgeon to the Manchester Royal Infirmary, of senior house-surgeon to the Royal Albert Edward Infirmary, Wigan, and of resident medical officer of the Barnes Convalescent Hospital, Cheadle, he entered the navy as surgeon in 1891. He was specially promoted to staff surgeon in 1900 for service in the South African war, became fleet surgeon in 1904, surgeon captain on September 11th, 1918, and retired in 1919. He served with the Naval Brigade in the South African war, taking part in the relief of Ladysmith, was mentioned in dispatches, and gained the Queen's medal with two clasps, a special promotion, and the D.S.O. During the recent war he was medical officer in charge of three hospital ships in succession. He contributed a description of the equipment and working of hospital ships to the special series of articles published in the BRITISH MEDICAL JOURNAL and afterwards collected in the volume *British Medicine in the War*.

Sir HUMPHRY ROLLESTON writes: Surgeon Captain E. C. Lomas's long and painful illness, by necessitating his retirement, was a severe blow to the Naval Medical Service, not only on account of his surgical and administrative abilities, but also for the loss of a specially attractive and lovable personality. He won the D.S.O. for the relief of Ladysmith in the South African war in 1900, and had a distinguished record in the service, his war work being recognized by the C.B. in 1916. He was senior medical officer of three hospital ships in succession; the *Maine* was wrecked off the coast of Scotland before the war, but he was not on board at the time on account of his wife's illness; the *Rohilla* was wrecked off the East Coast late in 1914, and Lomas suffered considerably from exposure before he could leave; the *Garth Castle* was a model and happy ship under his genial and tactful guidance. He subsequently organized and, in October, 1916, opened the Royal Naval Hospital at Granton, near Edinburgh, where I often saw him. Not only was he a most efficient organizer and, until administrative duties

absorbed his time, a keen and capable surgeon, but a most unselfish worker, never sparing himself, while looking after his subordinates in the most kindly way so that they were devoted to him. He was a gallant gentleman whom his friends, and they are many, will long regret.

DR. GEORGE GAUTBY, who died at his residence in Hull on February 18th, aged 57, was educated at Newcastle-upon-Tyne. He graduated M.B., B.S. Durh. in 1887, M.D. two years later, and became M.A. in 1909. He had practised in Hull for thirty years; he was Sheriff in 1908. He took great interest in the Free Church movement and in social affairs, and was a member of the Hull Division of the British Medical Association. He is survived by his widow and five children.

DR. THOMAS POWER, of Poplar, died at his residence there on February 16th. He was a student of Dr. Stevens's Hospital, Dublin, and took the diploma of L.R.C.P. Lond. in 1871. He settled in Poplar soon afterwards, and early won the respect of those among whom he worked. He was J.P. for the borough of Poplar, Public Vaccinator, and Medical Assessor to the Poplar Borough Council. The funeral took place at St. Patrick's Cemetery in the presence of a large number of mourners.

DR. ROBERT WM. GOLDIE died from valvular heart disease at Newbiggin-by-Sea, on February 23rd, in his 75th year. He was educated at Edinburgh University and Westminster Hospital, took the diplomas of L.R.C.P. Edin. and M.R.C.S. Eng. in 1868, and graduated M.D. Edin. in 1887. For twenty-two years he was medical superintendent of the Poplar and Stepney Sick Asylum.

DR. NUSSERVANJI FAKINJI SURVEYOR died of heart failure at Bombay on January 26th, aged 57. He was educated at Bombay University, where he graduated L.M.S. in 1890 and M.D. in 1892; then coming to England he took the M.R.C.P. Lond. in 1892 and the D.P.H. Camb. in 1893. In 1894 he was appointed physician to the Jamsetji Jijibhai Hospital, and at the time of his death was consulting physician to that hospital, and consulting bacteriologist to the Gokuekar Tejpal Hospital, the two chief Indian hospitals in Bombay. He had gained a considerable reputation as a bacteriologist by his researches on the subjects of plague and of madura foot or fungus foot.

Medical News.

PROFESSOR ROBERT BELLAMY CLIFTON, F.R.S., who died at Oxford in his 85th year on February 22nd, was an honorary member of the British Medical Association. He had held the chair of experimental philosophy at Oxford for fifty years (1865-1915). He was elected an honorary member of the Association on the occasion of the annual meeting at Oxford in 1868.

CLINICAL meetings are held at the Western Ophthalmic Hospital, London, N.W., at 5 p.m., on the fourth Wednesday of each month. Medical practitioners and others interested are invited to attend.

A DISCUSSION upon the eradication of tuberculosis in man and animals will be held in the Robert Barnes Hall of the Royal Society of Medicine on Monday, March 14th, at 5.30 p.m. The discussion will be opened by Sir John McFadyean, who will be followed by Sir Clifford Allbutt, Sir G. Sims Woodhead, Dr. Arthur Latham, Professor Hobday, Dr. A. C. Inman, Dr. Halliday Sutherland, Mr. Cyril Nitch, and others. The chair will be taken by the President of the Society, Sir John Bland-Sutton.

A COURSE for the D.P.H. (Conjoint Board in England) will be held at the Technical College, Bradford. The course in bacteriology will be conducted in the public health laboratories by Dr. William Campbell, lecturer in bacteriology and industrial diseases, and Dr. H. Cecil Robertson, assistant lecturer and demonstrator in serology and immunology. The course in chemistry will be under the direction of Dr. R. D. Abell, the head of the chemistry department.

FOR the last twenty years or so there has been some uncertainty as to the future of St. George's Hospital and its medical school; various proposals for their removal to some other site have from time to time been put forward, but we are now informed that this uncertainty has been set at rest. It has been decided that both hospital and school shall remain on their present site. The uncertainty has no doubt been to some extent detrimental to the school, but the teaching has never suffered, and the examination results for the past year have been most creditable. As the number of students recently has not been large, any candidate at all capable had a number of scholarships and prizes open to him, and was certain of getting a house appointment.

THE Medical Officers of Schools Association has convened a conference on "Punishments in the Schools," to be held on Friday, March 18th, at 4.30 p.m., in the Medical Society's rooms, 11, Chandos Street, W.I.

AT a meeting of the Royal Anthropological Institute, on March 8th, Professor F. G. Parsons, F.R.C.S., will read a paper on the head form of the long barrow race, with reference to the modern inhabitants of London, and on March 22nd Dr. F. G. Crooksbank will read a paper on the significance of Mongolian imbecility. The meetings are held at 8.15 p.m. at the rooms of the institute, 50, Great Russell Street, W.C.1.

AT the January Matriculation Examination of the University of London there were 148 successful candidates in the first division and 864 in the second division.

THE late Mr. Robert Francis Samuels of Liverpool has left £1,500 in trust to the University of Liverpool for the foundation of three Samuels medical scholarships in medicine, surgery, and obstetrics respectively in memory of his two deceased brothers.

AT a meeting of the Central Council of the Combined Universities Conservative and Unionist Association, Mr. W. Barnard Paraday, LL.B., barrister, and graduate of Manchester University, and Dr. Sidney C. Lawrence, medical officer of health for Edmonton, and graduate of Birmingham University, were unanimously adopted as prospective candidates for the Combined English University constituency at the next general election.

THE second International Congress of Pathology has been indefinitely postponed, as it is felt that it is impossible to establish cordial relationships between the pathologists of all nations at present.

AT a meeting of the Committee of the Royal Surgical Aid Society on February 15th, Mr. Samuel Watson, who has just retired from the offices of treasurer and chairman of committee, was presented with an illuminated address recognizing his valuable services during the past fifty-one years.

A COMMITTEE has been organized, under the presidency of Professor Luigi Zoja, to commemorate Carlo Forlanini, who died in 1918, by establishing a foundation for the study of tuberculosis. Subscriptions should be sent to Professor Ambrogio Da Gradi, Clinica Medica, Pavia.

THE annual congress of the Ophthalmological Society of the United Kingdom, with Mr. J. Herbert Fisher as president, will be held on May 5th, 6th, and 7th at the Royal Society of Medicine, Wimpole Street. The following arrangements have been made: On May 5th, in the morning, the President will deliver his opening address, and Mr. Maitland Ramsay will read a paper on "A case of cyclitis associated with swelling of the parotid glands"; and in the afternoon there will be a discussion on "The psychology of vision in health and disease," opened by Professor C. Spearman and Sir F. W. Mott. At 5 p.m. the Bowman Lecture will be given by Mr. E. Treacher Collins on "Changes in the visual organs correlated with the adoption of arboreal life and the assumption of the erect posture"; and in the evening the members will dine together. On May 6th, in the morning, there will be a discussion on "The treatment of manifest concomitant strabismus," opened by Mr. C. Worth and Mr. A. J. Ballantyne. In the afternoon the members will visit St. Thomas's Hospital, where a clinical meeting will be held, at which members are invited to show cases of interest. In the evening a number of papers will be read, including one by Lieut.-Colonel H. Herbert on "Results of the iridopropalpe operation for glaucoma." On the morning of May 7th there will be a business meeting, and further papers will be read. During the congress the optophone will be demonstrated in the Bowman Library. Members desirous of reading papers, showing cases, or taking part in the discussions are requested to communicate as soon as possible with Mr. F. A. Juler, 14, Portland Place, London, W.1.

Letters, Notes, and Answers.

As, owing to printing difficulties, the JOURNAL must be sent to press earlier than hitherto, it is essential that communications intended for the current issue should be received by the first post on Tuesday, and lengthy documents on Monday.

ORIGINAL ARTICLES and LETTERS forwarded for publication are understood to be offered to the BRITISH MEDICAL JOURNAL alone unless the contrary be stated.

CORRESPONDENTS who wish notice to be taken of their communications should authenticate them with their names—of course not necessarily for publication.

AUTHORS desiring reprints of their articles published in the BRITISH MEDICAL JOURNAL are requested to communicate with the Office, 429, Strand, W.C.2, on receipt of proof.

In order to avoid delay, it is particularly requested that ALL letters on the editorial business of the JOURNAL be addressed to the Editor at the Office of the JOURNAL.

THE postal address of the BRITISH MEDICAL ASSOCIATION and BRITISH MEDICAL JOURNAL is 429, Strand, London, W.C.2. The telegraphic addresses are:

1. EDITOR OF THE BRITISH MEDICAL JOURNAL, *Aitology, Westrand, London*; telephone, 2630, Gerrard.

2. FINANCIAL SECRETARY AND BUSINESS MANAGER (Advertisements, etc.), *Articulate, Westrand, London*; telephone, 2630, Gerrard.

3. MEDICAL SECRETARY, *Medisecra, Westrand, London*; telephone, 2630, Gerrard. The address of the Irish Office of the British Medical Association is 16, South Frederick Street, Dublin (telegrams: *Lactilus, Dublin*; telephone, 4737, Dublin), and of the Scottish Office, 6, Rutland Square, Edinburgh (telegrams: *Associate, Edinburgh*; telephone, 4361, Central).

QUERIES AND ANSWERS.

INCOME TAX.

"A MEDICAL WOMAN" asks for information as to the expenses deductible and the allowances to be made in the assessment of the income of herself and husband.

* Depreciation allowances cannot be claimed in connexion with professional earnings, and the original cost of motor-car and boat is a capital charge. Estimating the expenses roughly, the assessment of the income should work out somewhat as follows:

1. Husband, gross earnings	£290		
Wages and running expenses of motor, say	£100	—£190	0 0
2. Self, gross earnings	£610		
Wages and running expenses of motor, etc.	£150		
Rent and other necessary expenses	£100	—£250	—£360 0 0
			£550 0 0
Deduct 10 per cent. allowance for earned income			£ 55 0 0
			£495 0 0
Investment income			£ 27 0 0
Total assessable income			£522 0 0
Personal allowance	£225		
Personal allowance, wife's earnings ...	£ 45		
Child allowance	£ 35	—£306	0 0
			£216 0 0
Tax at 3s. in the £			£ 32 8 0
Less £28 life assurance premiums at 3s. ...			£ 4 4 0
			£ 28 4 0

"A. B." bought a car some years ago for £200; he has now replaced it by a car of the same make but higher horse-power, at a cost of £600, less £200 realized for the old car. The makers have ceased to build cars of the same horse-power as the first one.

* Theoretically the proper deduction to be made for income-tax purposes is the cost of a car of similar horse-power, less £200. The practical difficulty that no such car is now made can doubtless be surmounted by a reasonable estimate based partly on the rise in the cost of the higher powered car or the practice of other manufacturers. We assume, of course, that the original car was not purchased at second hand.

H. G. F." inquires as to the validity of his claims for allowance of (1) depreciation of motor cars, and (2) decoration of consulting room.

* (1) An allowance for depreciation is restricted to the assessment of "trades, manufactures, and concerns in the nature of trades," and by implication does not extend to professions. This distinction will be removed if and when the recommendation of the recent Royal Commission to that effect is carried out; in the meantime all the professional man is entitled to is the allowance of the cost of replacement of the car when that cost is incurred. No reduction of the claim for expenses on the ground that the car is used for non-professional purposes would be justified if such use has not increased the total cost of running. (2) The cost of redecoration of the consulting and waiting rooms seems undoubtedly

legitimate expenses, and we have not known any objection raised hitherto. We may add that if our correspondent took over the practice in 1920, his liability for 1920-21 would seem to be determined by the average profits of the practice for the three years ending December 31st, 1919, in which case the question of redecoration would not seem to arise at present.

"T. M. C." asks for additional information in reply to his question (December 13th, 1920, p. 957) as to the effect of his retirement from a firm on December 31st, with reference in particular to payments which the practice may make to him after that date.

* If the past assessments had been made on the basis of the value of the firm's gross bookings less expenses, it would be obvious to all concerned that "T. M. C." would be relieved of one-fourth of the assessment for 1920-21 in view of his retirement on December 31st, 1920. Any receipts that reached him in the form of payments for old debts would have been already taxed. The position is, in our opinion, precisely the same where the assessments have been based on cash receipts. When the assessment for 1920-21 was made, it referred to the income of the practice for that year, although it was calculated on an artificial basis, and the tax payable is in respect of that income, and not in respect of the cash receipts on which the tax is in fact calculated. There appears to be no legal reason why "T. M. C." should pay tax on more than three-fourths of his share of the firm's assessment for 1920-21.

SHIP'S SURGEONS.

"S. S." asks for information on the following points: (a) The present average pay of ship's surgeons; (b) whether it is difficult to get posts as such; (c) to whom does one apply—that is, the marine superintendent or who; (d) is much uniform expenditure necessary for casual voyages; (e) which are considered the best lines to go for? He is a retiring I.M.S. officer, a bachelor of 43, and does not want to sign on for a long period with any one line, but to get about the world on many different lines.

SEA WATER FOR INTERNAL USE.

"HALOD" asks whether there is any preparation of sea salt which can be used to make sea water fit to be taken internally. Two preparations have been suggested to him, namely, bay salt and Tidman's sea salt, and he desires to know whether they have been used internally, and, if so, in what strength.

LETTERS, NOTES, ETC.

AMAZIA (AMASTIA).

DR. A. KAYE JARRATT (Bridlington) writes: A girl, aged 13, examined by me, was found to have no left breast or nipple. The origin of the pectoralis major was from the first and second ribs, and when put into action the muscle stood out like a cord in a horizontal position. The mother attributes these abnormalities to a slight blow received by her when three and a half months pregnant. The blow was in an upward direction over the left breast. The condition is, I presume, the one known as "amazia."

INSECT VECTORS OF DISEASE.

DR. H. COMPIN PARSONS (Medical Superintendent, Ministry of Pensions Hospital, Cannon Chase, Hednesford, Staffs) writes: A large queen bee was knocked down by the bacteriologist at this hospital. On examining his quarry he discovered small beads of pus on the front pair of legs containing numerous pneumococci, *M. catarrhalis*, and *B. influenzae*. It is interesting to note that even in February living insects are found carrying micro-organisms for distribution in the food stores.

SIGNS AND SYMPTOMS.

DR. J. LEWIS THOMAS (Newport, Mon.) writes: That precision in language, spoken or written, Dr. Gee of St. Bartholomew's, in his *Essay on the Nature of Asthma*, on page 132, writes "symptoms" or "lesions of functions," and on page 134 defines symptoms as "disordered functions observed in patients during life."

VAGITUS UTERINI'S?

DR. M. I. MCNIEF (London, S.W.) writes: The following case might be of interest to your readers. I was called to a confinement on January 15th. On arrival I found the patient rather exhausted. She was a primipara aged 40. On examination the os was well dilated, but the head was high up. I administered chloroform and proceeded to apply instruments. When I had them almost in position I heard a baby's cry. I said nothing. Soon there was a second cry, quite plain, and nurse said to me "the baby is crying." The baby cried three times in all, and quite distinctly. I hastened delivery as much as I could, but it would not be seven minutes or more before I delivered it after the cry. On delivery it was cyanosed, with cord round neck. After a short period of artificial respiration it began to breathe normally, and in now a healthy baby.

SUPERNUMERARY NIPPLES.

DR. JOHN S. CLARKE (Woolley, Herefordshire) writes: In the course of examining between 8,000 and 9,000 men proceeding up to their units at the front I came across one case in which there were a pair of well-developed supernumerary nipples, as described by Dr. F. B. Skerrett (February 12th, p. 254). I also met with one case with a single supernumerary nipple, but in this man's case the supernumerary nipple was on the belly wall just below the costal margin—it was undoubtedly a rudimentary nipple. Both men were Welshmen. I have amongst my patients a woman who has two fully developed breasts, but on the left breast, below and slightly outside the normal nipple, is an accessory nipple. During lactation milk could be expressed and the baby was able to suck from it. The woman refused to allow me to take a photograph, nor would she consent to allow herself to be shown at a medical meeting.

SEVEN GREAT-GRANDPARENTS ALIVE.

DR. S. L. CORRY (Uraidla, South Australia) writes: With reference to Dr. J. Robertson Hall's letter in the BRITISH MEDICAL JOURNAL of November 13th, 1920, and "A. G.'s" letter of November 20th, 1920, it may be of interest to relate that in my district is a small boy of 2 years, whose parents, two grandfathers and two grandmothers, four great-grandfathers and three great-grandmothers are all living. Soon after the baby's birth these relatives were photographed as a family group.

PREDISPOSING CAUSES OF CONSUMPTION.

DR. ERNEST KINGSCOTE (London, W.1) writes: In Sir James Mackenzie's letter in your issue of February 12th he states that in twenty-eight years of general practice many of his patients developed consumption, but that most of them were previously ill for many years and under his care for a variety of complaints. It occurred to him that these complaints may have been due to conditions which predisposed to consumption. Now, one of these, according to the French school, is gastric dilatation and consequent hypochloridrosis; another is restricted movements of the upper chest. Both of these conditions predispose to consumption. The one lowers the vitality, and therefore the fighting power of the phagocytes, through imperfect digestion, mal-assimilation, and auto-intoxication; the other through imperfect oxidization and retention of carbonic acid gas. These conditions should be recognized early and treated. The fixed lung apices form a convenient nidus for the tubercle bacillus. These fixed apices can readily be made to move again by the breathing exercises for the reproduction of lung elasticity in emphysema and other forms of fixed chest, which I demonstrated before the Medical Society of London on November 8th, 1920. The reproduction of the movement and the consequent dilatation of hitherto unused healthy air vessels also tend to benefit the patient even in advanced cases of phthisis pulmonalis.

"T.B. OFFICER."

DR. E. WEATHERHEAD (Alderley Edge, Cheshire) writes: Is it not time that some one with a respect for the proper use of medical phraseology should call attention to the ridiculous method of abbreviation—"T.B. Officer"—which seems to be rapidly becoming universal, to denote "tuberculosis officer." Whether it originated in the Army Medical Service I know not, but I cannot remember its use prior to the war. This has already taken such firm root that letters are frequently addressed in this fashion, even by Government authorities, and in one report-form at least, issued by the Ministry of Pensions to tuberculosis officers, the place for that officer's signature is subscribed "T.B. Officer for —." Imagine any medical man who specializes in one disease being designated in terms of the micro-organism specific to that disease! The specialist in syphilitic disease would become "S.P. Officer," and so on. Let tuberculosis authorities at any rate discountenance such slovenliness in nomenclature. Is the objection to T.O., that the tuberculosis officer might be mistaken by the uninitiated for the transport officer?

MALIGNANT TERTIAN MALARIA CONTRACTED IN ENGLAND.

DR. W. M. McDONALD, District M.O. and M.O.H. Antigua, British West Indies, writes to suggest that the case described in the note of Professor Glynn and Dr. Matthews in the JOURNAL of November 27th, 1920, p. 811, as an example of malignant tertian malaria contracted in the North of England was an example of long-standing infection. His experience of more than twenty years in a highly malarious country is that hundreds of patients with subtertian malaria suffering from headache and feeling tired and out of sorts go to a doctor for a tonic without being aware that their temperature is raised. He mentions the case of a boy, aged 17, whose blood was crowded with crescents; he walked several miles to the surgery for a tonic, received medicine, and went back to his work as a field labourer next day. Such an infection, however, if untreated, will culminate sooner or later in a pernicious attack. Dr. McDonald considers that the blood count in the North of England case, the increase of mononuclears, and the corresponding decrease in polymorphs are indicative of chronic malaria. In his own experience the increase of large mononuclears is hardly perceptible in an initial attack, but grows after each subsequent attack. He has found an

increase of large lymphocytes and a diminution of small lymphocytes a marked characteristic of malarial blood. With regard to the assumption that the patient was infected on September 27th with malarial fever, beginning on September 29th, he writes: During twenty years in the West Indies I have never seen nor have I heard of any newcomer suffering from malarial fever within three days of arrival, although *Anopheles* abound and infection abounds. I should regard it as quite impossible for a patient to show symptoms two or three days after being bitten by infected mosquitos. After reading the history of the case very carefully, I should imagine that this patient contracted malaria many years ago from an infected mosquito in a park or the country round Liverpool. In a place like Liverpool there must be many infected persons from abroad, and the *Anopheles* in this neighbourhood are therefore open to infection. I would suggest that the headaches to which the patient was liable were due to malaria, and that, had her temperature been taken at such times, it would have been found to be slightly raised, and that her paleness and lack of strength were directly due to chronic malaria.

COMBINATION IN THE ELECTRO-MEDICAL INDUSTRY.

AMALGAMATION seems to be the order of the day in the electro-medical and x-ray industry. The Cox-Cavendish Electrical Company, of Harlesden, itself a combination of two older firms, has combined its manufacturing resources with those of X Rays, Limited, of London, comparatively a new but an energetic house. The firms are to retain their separate identity so far as their commercial activities are concerned, but in the designing and manufacture of their apparatus they will share each other's factory facilities, and their research staffs will work together as one organization. It is expected that this combination will result in larger scale production, particularly of high tension apparatus, with consequent economy, not only to the co-operating firms, but to their customers.

AGE AND PENSIONS.

"AETAS" writes: The argument in my letter (February 12th, p. 249) that age is not a cause but a measure of disability ends up with what appears to be a *non sequitur* in the statement that "old age is a disability." As the whole subject requires careful thought and reasoning, may I insert a few words left out of my argument by the printer? The passage then reads:

"In practice the disabilities of older soldiers, though very real in economic effect (to compensate for which is the true purpose of disability pensions), are often difficult to define in terms of disease. The truth is, old age itself is, in fact and in effect, a true disability, which requires recognition in disease nomenclature, if only for the convenience of the term in summarizing a state of disability which, being compounded of many accumulated residues of disease and strain, does not easily fall into any one particular existing disease category. In short, old age is a disability which may be, and usually is, aggravated by service, and that aggravation cannot pass away."

VACANCIES.

NOTIFICATIONS of offices vacant in universities, medical colleges, and of vacant resident and other appointments at hospitals, will be found at pages 35, 36, 37, 40, 41, and 42 of our advertisement columns, and advertisements as to partnerships, assistantships, and locum tenencies at pages 33 and 39.

THE following vacant appointments of certifying factory surgeons are announced: Barton-on-Humber (Lincoln), Brading (Isle of Wight), Bromyard (Hereford), Wincanton (Somerset).

DR. O. K. WILLIAMSON, who was recently appointed to the Chair of Medicine at University College, Johannesburg, will not take up his new duties until February, 1922, and will not leave England until towards the end of the present year.

IN sending their new catalogue of French medical books—Messrs. Hachette, the well-known French publishers and booksellers of 18, King William Street, W.C.2, state that they welcome inquiries for foreign medical and scientific works.

SCALE OF CHARGES FOR ADVERTISEMENTS IN THE
BRITISH MEDICAL JOURNAL.

	£	s.	d.
Six lines and under	0	9	0
Each additional line	0	1	6
Whole single column (three columns to page)	7	10	0
Half single column	3	15	0
Half page	10	0	0
Whole page	20	0	0

An average line contains six words.

All remittances by Post Office Orders must be made payable to the British Medical Association at the General Post Office, London. No responsibility will be accepted for any such remittance not so safeguarded.

Advertisements should be delivered, addressed to the Manager, 429, Strand, London, not later than the first post on Tuesday morning preceding publication, and, if not paid for at the time, should be accompanied by a reference.

NOTE.—It is against the rules of the Post Office to receive *post-restante* letters addressed either in initials or numbers.

Remarks ON THE INDICATIONS FOR CHOLECYSTECTOMY.

A PAPER READ BEFORE THE MANCHESTER MEDICAL
SOCIETY.

BY

K. W. MONSARRAT, F.R.C.S. EDIN.,

SURGEON TO THE NORTHERN HOSPITAL, LIVERPOOL; LECTURER IN
OPERATIVE SURGERY IN THE UNIVERSITY.

If we may judge by their writings, it cannot be said that the minds of surgeons are yet made up as to whether removal of the gall bladder should be the normal operation in cases of cholecystitis. I quote from two papers, both written by a surgeon of high repute, and both published in the same year. In one, speaking of cholecystostomy, he says "this operation saves this valuable organ for future function." In the other he writes: "Practically all cases of cholecystitis and 80 per cent. of cases of gall-stone disease should be treated by cholecystectomy." In a recent textbook I read: "There is much divergence of opinion on the question of cholecystostomy *versus* cholecystectomy even among the writers of this volume, some preferring cholecystectomy whenever it can be done, others limiting its use to cases in which the gall bladder is small and shrunken." Examples of the same divergence of opinion might be multiplied.

The question has to be considered from physiological, pathological and clinical standpoints. From the physiological point of view it has to be asked, what is the function and functional value of the gall bladder? It is not found universally among mammals: of the domestic mammals the solipeds, the horse tribe, are without it. The horse has a single ductus choledochus which opens into the duodenum by the way of an ampulla of Vater. The ox, the pig, the dog and the cat possess it. It is present in birds, but in them there are two or more bile ducts, the gall bladder being a diverticulum on that which leads from the right lobe to the duodenum. Physiologists are for the most part silent as to its function, but down to recent years it has been an accepted doctrine that by periodic contractions it floods the duodenum with bile when food passes from the stomach into this part of the intestine. There are difficulties in the way of accepting this theory. It has been pointed out that the amount of bile excreted in the human subject is from thirty to fifty ounces in the twenty-four hours, and that the capacity of the bladder being but one ounce it can hardly be considered a reservoir. This is true for man, who feeds habitually at four or five hour intervals, and whose duodenum contains food at corresponding intervals. Under these conditions the gall bladder can hardly have much functional value as a reservoir determining the admixture of bile with food.

In other animals, continuous feeders, the pylorus is relaxed at frequent intervals to allow the passage of food, and in them there may be a mechanism associating this passage of food into the duodenum with contractions initiated in the gall bladder. The reservoir theory is not to be lightly thrown aside because it does not appear to work in with the habits of man; if it is the true explanation of the function of the gall bladder, then in man this organ is of little value physiologically.

Mr. W. J. Mayo has adopted another theory, that the gall bladder "takes the tension from the common and hepatic ducts, and that the mucus it produces reduces the chances of pancreatic and other complications." This may be called the "safety-valve" theory. It supposes the development of an organ as a safeguard against a possible pathological condition. Such an event cannot be brought into line with any theory of the development of organs of which I am aware. An extraordinarily clumsy way this of avoiding regurgitation of bile into the pancreatic ducts when the other path, the dissociation of biliary and pancreatic ducts, was developmentally open and obtains in many vertebrata.

In the horse, which possesses no gall bladder, subacute pancreatitis has been described only as a consequence of the penetration of foreign bodies; acute pancreatitis has only once been described in the horse, three times in the dog, according to Hutyrá and Marck. These figures are of course too small to reason from, but at any rate attention

may be drawn to the fact that these authors are only able to put on record one case in the horse, which has no gall bladder, in which the cause may possibly have been regurgitation of bile into the pancreas, and the horse is one of the domestic animals whose morbid conditions have been most thoroughly investigated by veterinary medicine. The "safety-valve" theory practically receives its quietus when we find that in the solipeds the bile duct and the pancreatic duct are associated in an ampulla of Vater, yet there is no gall bladder, whereas in the large families of which the ox and the pig are examples a gall bladder is present, but the ductus choledochus and the ductus pancreaticus open separately into the intestine. There is no real alternative to the reservoir theory, which supposes periodic contractions associated with pyloric relaxation. The dietetic habits of man have, however, rendered this reflex of no physiological value to his digestive system.

The gall bladder is a diverticulum with a very narrow neck, the average diameter of the cystic duct is about one-eighth of an inch. It is, therefore, a diverticulum in which stagnation may readily occur. In its normal content, bile and mucus, most types of micro-organisms can be cultivated, and under conditions of stagnation, virulence and multiplication are increased. The source of infections in the bile channels is the portal circulation. Under conditions of health bacteria carried to the liver from the alimentary canal and other abdominal viscera are destroyed there or so attenuated as to be innocuous. Under pathological conditions this destruction or attenuation is subnormal, and infections of the bile channels may result. Infections of the urinary passages occur under analogous conditions. When infections of the bile channels occur the gall bladder is the site where they tend to persist. One result of the infection may be the formation of gall stones, but the primary condition is that of infection. Whether gall stones form and complicate the infection depends upon the relative proportions of cholesterol and bile salts. Cholesterol is a pure excretion, it is insoluble in water but soluble in solutions of bile salts; when the amount of the latter is insufficient relatively cholesterol passes out of solution. Cholesterol is thrown off in increased quantity from tissues which are undergoing pathological changes, and concretion formation is a consequence of the rise in the relative amount of cholesterol in bile following infection.

The problem in the treatment of cholecystitis, whether associated with gall stones or not, is to arrest the infection and obviate its recurrence. For anatomical and pathological reasons it appears only remotely possible that a gall bladder that has suffered infection and inflammatory reaction can be trusted to remain quiet. We are becoming increasingly acquainted with a group of cases in which, without any gross inflammatory reaction in the gall bladder itself, the patient's health is undermined by a chronic cholangitis the nidus of which is the gall bladder, recovery from the chronic cholangitis following cholecystectomy. Some of these patients, if watched over long periods, may show an occasional transient gall-bladder distension and tenderness, but this phenomenon does not always occur. These cases do not come within the scope of this note, and I mention them only to illustrate the fact that even the structurally normal gall bladder may harbour an infection sufficient to disorganize liver function and produce chronic ill health. The chances that a bladder and cystic duct structurally damaged by inflammation can be reasonably expected to cease to harbour and engender infection would seem to be small.

The test of a successful operation for cholecystitis is whether the infection of the bile channels clears up, the liver function returns to normal, and the patient does not suffer from symptoms referable to adhesions between neighbouring viscera nor from other symptoms arising from recurrent inflammatory reaction in the operation area. My own experience is that a considerable proportion of cases of cholecystitis treated by drainage fail to pass this test. Admitted that when gall stones are associated with the cholecystitis a return of concretions is unusual when cholecystostomy is performed, a considerable number of patients so treated suffer ill health of one kind or another referable to the persistence of the gall bladder as a centre of infection—ill health due to persistent chronic cholangitis with chronic pancreatitis, recurrent attacks of pain and tenderness in the

neighbourhood of the wound, gastric distension, spasm and sometimes vomiting due to angulation of the pylorus and duodenum by adhesions.

To avoid these complications, to get rid of a potential source of recurrent infection in the biliary channels, it appears advisable to remove a gall bladder which has been attacked by cholecystitis of whatever type. The contraindications are not local but general. In a small proportion of cases it may be advisable, in view of the patient's age or feebleness, to limit the operative procedure to the somewhat less exacting cholecystostomy after removal of calculi if present. With this exception, cholecystectomy should be the rule in acute, subacute and chronic cases. It is necessary to make certain that after its removal no obstruction will remain in hepatic and common ducts. If this is demonstrated beyond doubt, there is no need, even in cases where there is jaundice, to provide external drainage of one or other of these ducts; the indication for external drainage is an associated pancreatitis, and if this is present it is necessary to drain the common duct externally by rubber tube.

Patients who have had the gall bladder removed do not suffer any demonstrable disadvantage from its absence; in the case of calculous cholecystitis they are relieved of the double risk of the re-formation of stones and the persistence

of bile duct infection; in the case of cholecystitis without calculi they are relieved of a diverticulum which would in all probability prove the source of a recrudescence of their intoxication.

An operation field which permits a proper examination of the bile ducts is adequate for cholecystectomy. The operation may present considerable difficulties when the gall bladder is shrunken and lies embedded in adhesions—it is in this condition that its removal is most necessary if recurrent attacks of infection are to be avoided. Under other circumstances its removal is simple. The raw surface left can often be obliterated by suture, or sometimes an omental graft is useful for the purpose. If this is done, and the stump of the cystic duct touched with the cautery, a clean operation field is left in which adhesions are unlikely to form. The operation is altogether a cleaner performance than cholecystostomy in which the gall bladder is opened *in situ*, and some infection of the wound is difficult to avoid. If it is true that the gall bladder is of no particular functional value in the human subject, that it is the nidus of persistent infections in the biliary channels, that its removal is not a more serious operative risk than cholecystostomy, the argument for cholecystectomy as the normal operation in cholecystitis is overwhelming.

ASTHMA AND ANAPHYLAXIS.*

BY FRANK COKE, F.R.C.S.

THE whole subject of anaphylaxis is of very recent origin; it is also very complex. It will therefore be well to have some general description of this strange phenomenon before passing to the claim that asthma be considered as a symptom of anaphylaxis or protein poisoning, and not otherwise a separate entity.

Charles Richet,¹ in 1902, injected a dog with a dose of poison derived from the tentacles of the actiniae and with no harmful effect whatever. Twenty-two days later he reinjected the dog with exactly the same dose, expecting to reach larger doses later and a condition of prophylaxis to the poison. To his surprise, hardly had he finished the injection when the animal became extremely ill and died in thirty-five minutes. This being the exact opposite of prophylaxis, he called it anaphylaxis.

Numerous experimenters in many countries have since investigated this question; detailed accounts may be found in the books of Richet,¹ Besredka² and Danysz.³

Apart from Richet's experiments, an explanation is found for many curious facts noted previously by Hyman⁴ and others, even by Magendie in 1839. It is found that any form of protein, serum, white of egg, milk, or cereal, has the power of rendering an animal sensitive to another dose of the same protein, which, when given, will instantly produce the anaphylactic syndrome—even to the point of death—in seconds. The next peculiar point is the absolutely specific nature of anaphylaxis. An animal sensitized with horse serum will not react to an injection of beef or any other serum except that from a horse. But no matter what kind of protein is used for the sensitizing and exciting dose, the anaphylaxis resulting is always the same.

The symptoms of anaphylaxis vary in the different animals. The typical picture, applicable even to man, appears as follows:

Provided a sensitizing dose has been given, and a sufficient incubation period of about ten days has elapsed, at the second

or exciting dose the animal is in trouble almost before the injection is finished. It becomes restless, scratches its muzzle as if irritated; the respiration is quickened, then difficult; vomiting takes place, especially in dogs; there is diarrhoea, with the passage of blood; micturition occurs; tetanic spasms and somersaults give place to paralysis and collapse; cessation of breathing brings death. There is marked eosinophilia and other blood changes.

There is at present no complete explanation of this remarkable syndrome. A diagram will serve to visualize the whole subject and to give a rough working explanation of many of the points in connexion with anaphylaxis.

The diamonds, A, B, C, C', D, represent varying quantities of antigen, horse serum, which are injected into the guinea pig, E, F, G, below, such antigen being marked by horizontal lines. The body—that is, the blood and cells—is incapable of making use of this raw protein, or of eliminating it as such in the urine, nevertheless it disappears in the blood. Therefore it must undergo some change of a digestive nature inside the blood or cells. (There is no room for exceptions to rules in a short article.)⁵ The lower thin line, at F, denotes the potentiality of the blood to produce this internal digestive mechanism and, may be, this is in normal working order to deal with infinitesimal quantities

of undigested (by the bowel) proteins that pass through into the blood and cells from time to time or arrive there through the lungs. Under the stimulus of the protein injected (A), this mechanism (vertical lines) becomes active as it has never been before, and the protein disappears, G to H, until a time comes at the end of some ten days, H, when this digestion is finished and abruptly ceases. An excess of this digestive substance, J, then passes freely into the blood, whilst the

further formation of it sinks to normal, a mere potentiality, as shown by the thin line, K.

There is certainly a moment in the diagram, about H, possibly, too, in the real anaphylaxis it is meant to portray, when there must be antigen and antibody, protein and digestive substance, present together enough to cause a small anaphylaxis. It is at this moment when the serum rashes appear. Is this possibly their explanation?

The blood then contains the antibody or the toxogenin of Richet, the sensibilisin of Besredka, the precipitin of Friclberger, or more simply (here) a digestive substance. The animal is now sensitive. A further injection, B, of antigen horse serum meeting the antibody, J, in the correct proportion, and meeting it suddenly, will immediately cause the anaphylactic syndrome to take place, the large black bar, L. It is now apparent why no anaphylaxis occurs until the incubation period is over. If more antigen is injected during the incubation period, all that will occur is that the time when sensitization

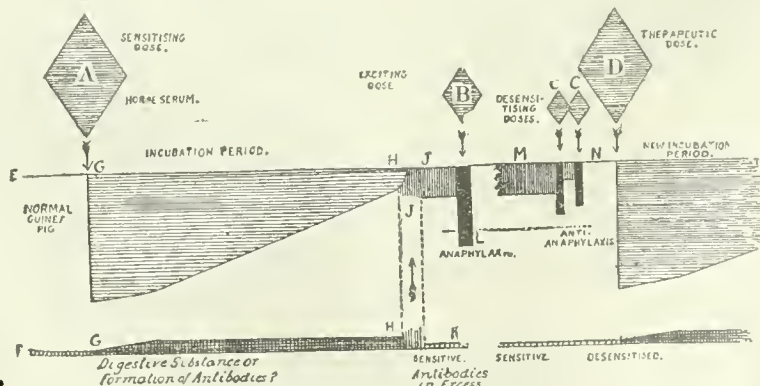

* The substance of a lecture delivered to the Tunbridge Wells Division of the British Medical Association, November 25th, 1920.

appears will be postponed until the increased quantity of horse serum has been digested. But once sensitive, the animal will remain so for years, even for the rest of its life.

Apart from the various theories of the physico-chemical or biological upset that takes place in anaphylaxis, it is certain that the central nervous system plays an important part, for under an anaesthetic anaphylaxis will not develop, the animal waking up with the crisis safely passed and with the gain of some measure of immunity or rather desensitization.

No matter what protein is used in the experiments the resulting shock and all its symptoms are always the same.

Passive anaphylaxis. If the blood of the guinea-pig which is sensitive to horse serum, about 3, be injected into another guinea-pig that fresh guinea-pig at once becomes sensitive to horse serum, and a dose of horse serum injected, at once without any incubation period, will immediately cause anaphylaxis. Further than this, if the guinea-pig's blood sensitized to horse serum be withdrawn and mixed in a flask with horse serum, the anaphylactic poison, whatever it is, is formed there *in vitro*, and if now injected into a new guinea-pig the latter is seized with anaphylaxis at once.

Anti-anaphylaxis of Besredka.² A certain sized dose of antigen is needed, and it must be injected quickly to cause anaphylaxis. Anti-anaphylaxis is the using up of this excess of digestive substance or antibody J and M by small doses C C, when the animal will become desensitized, N, and large doses, D, can then be given with impunity.

It will thus be seen that the horse serum is used in three different ways: as a sensitizing dose A, as a lethal exciting dose B, or as a curative desensitizing dose C C. In the desensitization by antigens of human beings who are variously sensitive to these antigens, great care is necessary to make certain that the size of the dose is suitable.

Such is a brief description of anaphylaxis, and it must be clearly understood that the diagram in no way enters into the controversy of how anaphylaxis really takes place; the digestive theory may be wrong from top to bottom, but in the meantime it does give a working explanation of the experimentally observed facts.

The Clinical Side of Anaphylaxis.

True anaphylaxis in man after a second injection of protein is rare, but many cases are on record.

A practitioner in India¹ gave himself a dose of antiplague serum, and in a year's time gave himself another. He was instantly seized with fainting fits, coma and asphyxia, and died in a few hours. With the frequency with which serums are now given more of such accidents may be expected. They may be avoided by small preliminary injections, C C, the anti-anaphylaxis of Besredka, by giving the injection very slowly,⁶ a special syringe—the Woodvatt pump—having been devised for this purpose, and by noting any sensitiveness by the skin reactions, as detailed below. If actually developed, anaphylactic shock may be treated by anaesthetizing the patient, whilst adrenalin or epinephrin will probably keep minor manifestations in abeyance.

ASTHMA AND ANAPHYLAXIS.

Apart from these very rare cases, there are a large number of complaints which have greater or lesser claims to be considered as anaphylactic symptoms of protein poisoning, and no longer as separate diseases. Chief amongst these is asthma. The case for asthma will be given very fully, and at various points of the argument other complaints that seem to come under the same headings will be noted. Anaphylaxis results from sensitization to foreign proteins. Half the cases of asthma can be proved to be due to sensitization by foreign proteins. In Allbutt's *System of Medicine*, asthma and hay fever are considered together in the same article. Hay fever is due to sensitiveness to pollen, not as a mechanical irritant, but from its protein content. An attack of hay fever can be excited in a susceptible patient by an injection of the pollen protein hypodermically and in mid-winter.⁷

Now the sensitiveness to the pollen can be tested for by placing pollen in the conjunctival sac. Test sets for the timothy grass are supplied from St. Mary's Hospital laboratories, where much of the work that led up to the American investigation was performed. Later, this method was transferred to a scratch on the skin, when an urticarial wheal can be produced. Further, it had long been noticed that some cases of asthma were undoubtedly due to the presence of animals—for instance, cats and horses. The next step was to see if a skin reaction could be obtained by the proteins of horse dandruff or cat hair, and the

human hair and one other proteins with which we come in daily contact. To cut a long story short, this method has proved eminently satisfactory and feasible, and by its means the cause of 50 per cent. of asthmatics can be determined. Dr. Freeman being the first to lecture on this subject in England.

Technique of the Skin Reaction.

The inside of the arm and forearm are cleaned, and a scratch $\frac{1}{2}$ in. long made with a scalpel, not going deep enough to draw blood. On to this the protein and solvent are placed. The tests should be an inch and a half apart. On the two arms a number of tests can be made at a sitting, though sometimes it will take three or even four hours to complete a test. A positive reaction consists of an urticarial wheal not less than $\frac{1}{2}$ in. across. This appears in from ten minutes to half an hour. Sometimes they are as large as a halfpenny with irregular branches coming out of them.

These reactions vary enormously in different people, so much so that some experience is necessary to judge the degree of reaction present. The proteins I use fall into four main groups: Some 70 foods, 20 bacterial proteins, 10 kinds of animal hair, and 10 pollens; also various face powders, etc. A full testing may take four sessions of an hour each.

Very rarely the history is clear enough to enable one to mark the offending protein with the first test, but much time is saved in the long run by a complete examination.

For instance, one patient could only give me a very short time. He was very sensitive to hen feathers. He gave up his feather pillows and feather bed, and his two eiderdowns, which he always used for warding off a chill and the asthma at night! Much of his asthma went, but not all. Further testing showed him sensitive to rice and beans, the rice undoubtedly being responsible for his last attack. He is now clear of asthma.

Multiple reactions are very common, as the following case will show.

A child 5 years old, with a strong family history of asthma; eczema and urticaria always; asthma continuously day and night for one year. The skin reacts on were banana, cabbage, eggs, and rhubarb ++++; barley, beans, rye, and oats ++++; beetroot, carrot, chicken, lentil, orange, potato, wheat, and rabbit fur ++; articles to which he was not sensitive were apples, beef, Bird's custard powder, Colman's cornflour, cocoa, codfish, coffee, haddock, herring, milk, lettuce, pear, pork, rusks, rice, lamb, tapioca, veal, horse dandruff, and hen feathers. On a diet chosen from articles to which he did not respond this boy has had no asthma since the first day he came to see me. It surprised me that he should be sensitive to cabbage, but I find that is quite a common thing to be sensitive to. His mother was perfectly certain that I set upset him, I was equally certain that it did not; he now takes large quantities of it. This child had been seen by many eminent medical men in London and Edinburgh both for his asthma and his eczema, but without the skin tests it is difficult to see how a correct dietary could ever have been drawn up.

An explanation is now given to the extraordinary likes and dislikes of these asthmatics in their food, their personal surroundings, and their locality.

A girl, aged 9, had asthma continuously for six years except for a break of eleven months whilst at Exmouth. She came back to London and the asthma recommenced at once, so she went back to Exmouth. There she had asthma this second time, rather worse than she had ever had it anywhere before. This is quite a common kind of history. I was asked to test her in St. George's. She gave horse dandruff ++++; cat ++++. Her "animal history" was that she had always had a cat at home but none at Exmouth the first time. The second time she visited Exmouth there was a cat and a dog there which she played with all the time. She had then been in hospital six weeks with no asthma. She was given the hospital cat to nurse from 5 to 6 p.m. At 1 a.m. she woke up with a typically bad attack of asthma. This explains why so few have asthma in hospital; they leave the article they are sensitive to at home.

One more case. I found a girl very sensitive to dog hair and to nothing else. She got rid of the dog and her asthma went. Some months afterwards she went to the sea and had had asthma the first night. In the morning she would have stopped there and had asthma for a few days, and then gone home because the "sea air" did not suit her. Having great faith, however, she made inquiries, and found that the people who had left their rooms had found cats and all four had slept on the rug which covered her bed.

The absolutely specific nature of anaphylaxis is well copied by these asthmatics. Now 50 per cent. of all asthmatics and some 90 per cent. of asthmatic children give reactions. One of the most interesting reactions is that given to human hair, several married patients who are sensitive to it being convinced that they are best when sleeping apart from their husband or wife, as the case may be. It is undoubtedly "foreign"—that is, different from

the blood serum. Hen feathers, chicken meat and eggs, even the white and the yolk, are all different as proteins, and I have had patients sent to me who are only sensitive to one of these.

The following case illustrating passive anaphylaxis, published by Ramirez,⁹ is of great interest:

A man was transfused with 600 c.cm. of blood from a donor, with no immediate discomfort. A fortnight later, on going out for a drive, he was seized with violent asthma, never having had such a thing previously. It was found that the donor he was transfused from was an admitted horse asthmatic, sensitive to 1 in 50,000 horse dandruff protein. His sensitive blood at J in the diagram had been transferred to this new man and had sensitized him—to wit, a skin reaction to 1 in 20,000 of the protein.

No less interesting is the fact that another man who received even more blood from this same donor did not develop asthma. What was there in his blood that had avoided sensitization? Or was he sensitized but did not show it by asthma? Their blood groupings are not stated, but presumably they were the same.

Certain individuals are sensitive to other things than proteins.

I examined a patient who gets asthma at once on taking half a grain of aspirin. Another was recently unconscious for ten hours in an asthmatic seizure after being given a kindly night-cap of 5 grains of aspirin. In other people aspirin, quinine, and iodoform or antipyrin^{11,12} give rise to a profuse urticaria. If the serum of these people be injected into animals, the animals become sensitized to the drug. They become extremely ill when these drugs are then administered to them, whereas the controls give no symptoms. Pagniez¹⁰ states that, serum from asthmatics having been injected into guinea-pigs, asthmatic attacks can be produced in them by injecting them with a solution of the Charcot-Leyden crystals, which the French consider to be made of tyrosin.

These asthmatics show many other idiosyncrasies to food and other proteins quite comparable to the other symptoms of anaphylaxis. It appears that, given the entry of a foreign protein, it is a matter of luck or pre-disposition what symptoms are called forth.

The connexion between asthma, hay fever, and paroxysmal sneezing is well known. Any of them may be due to pollens, animals' hair or the dust of tea or flour. They simulate the nasal irritation of anaphylaxis. Sometimes a simple hoarseness takes the place of both. Vomiting is common.

One child, who is only sensitive to rabbit fur, vomits, as the father says, at the sight of a bowl of rabbit broth. Another patient, who reacts to a solution of 1 in 10,000 of white of egg, is sick even with the glazing on the top of a bun or with a spoonful of soup cleared with white of egg, an inconvenience that overtakes him in a few seconds. Another patient, who has not taken honey for thirty years because it makes him sick instantly, in spite of this interval still gives a +++ reaction to honey. Those patients who are sensitive to animal hairs must avoid circuses and the Zoo. I had a patient who had to be actually carried out of the monkey house. Another who went to a performance of the "Garden of Allah" only saw the first act.

Eczemas and urticarias are very common with asthma, but even alone they give much the same proportion of skin reactions¹³ and are, in fact, merely symptoms from the same protein cause. The ragweed pollen may cause eczema without any asthma or hay fever.¹⁴ A patient who gives a reaction to one member of a group will very often be sensitive to other members of the same group—that is, the hairs, cereals or legumens—probably because they contain some of the same proteins as those in the article tested. Epilepsy is common with asthma and migraines, and is also in the same category.

While the Americans have devoted their energies to the skin tests, the French go to prove all these complaints as anaphylactic by various blood changes.

Widal, Abrami,¹⁵ and their collaborators have discovered a "crise hémoclasique," as they term it, which takes place in anaphylactic shock, in protein shock, and also in asthma, urticaria, migraine, and epilepsy, in paroxysmal haemoglobinuria, in malaria and other parasitic complaints when large quantities of protein are thrown suddenly into the blood stream, and also in those absorbing proteins from their own wounds; as a side issue on this, the rapid removal of tourniquets, massage, and squeezing of the limb with bandages is contraindicated even in civilian practice.

The "hémoclasique crise initiale" consists of a fall in blood pressure, a leucopenia, the leucocyte count falling

from 12,000 to 4,000 or even less, and many other less easily observed changes in the coagulability of the blood, its refractive index, the colour and substance of its clot.

The "marchand de mouton"²² had dealt in sheep for nearly forty years, during the last three of which he had become so sensitive to the smell of sheep that he had to give up his trade. In hospital he, of course, had no asthma. For the experiment he entered a pen of sheep. His leucocyte count and blood pressure were taken every few minutes. After two hours both fell, the leucocyte from 12,000 to 6,000. They then rapidly returned to the normal. During this time he felt no difference in himself. At the end of three and a half hours, when the crisis was completely over, he developed a very bad attack of asthma.

Another man had migraine, especially after chocolate,²¹ but only at times. He had chocolate each morning in large quantities, followed each time by a normal digestive leucocytosis, until there came a morning when the blood pressure and leucocyte count both dropped. Shortly after this gastric disturbance and a bad attack of migraine came on.

In all cases the blood crisis passes without any knowledge of inconvenience to the patient, but, having passed, the asthma or migraine at once develops. With certain cases of paroxysmal haemoglobinuria all that is necessary to initiate the paroxysm is to place the patient's hands in a bowl of very cold water. The blood crisis follows at once, and later the haemoglobin appears in the urine.¹⁸ But because these blood changes are present in this variety of conditions and after the injections of proteins into the blood, it does not, of course, necessarily mean that they must all be true anaphylaxis. Besredka² says that naturally intravenous injection of large quantities of foreign protein, or what not, will give rise to a shock, but he refuses to call these various intravenous protein shocks anaphylactic, unless the same shock is caused when the substance is injected intrathecally.

Cowie and Colhoun,¹⁶ in their article on the blood changes in connexion with the non-specific protein therapy by means of injections of antityphoid vaccine, note this same initial leucopenia, etc., of the "crise hémoclasique" but differentiate this protein shock from that of anaphylaxis by the absence of an eosinophilia. This increase of the coarsely granular cells staining with eosin is always present in anaphylaxis. Of other complaints in which it is noted in man, the asthmatic attack is the one of all others in which it is most extensively found. The sputum may be packed with them, in the blood they may be half the number of white cells present. Eosinophilia may, then, be another link to bind these anaphylactoid conditions together. Moschcowitz¹⁷ notes that it is present in the subjects of asthma and hay fever, and in their secretions, in the urticarial wheals and bullae of a great many skin diseases, in mucous colitis, in pellagra, and after an injection of tuberculin, in tetany, hemicrania and epilepsy. It is also a point of great diagnostic value in intestinal parasites. Note the common occurrence of epilepsy, urticaria, even asthma, with worms—that is, an absorption of foreign protein?

Now what of the 50 per cent. of cases in which we do not get a reaction? One is surprised to find how little interest is taken in those cases by the Americans. The type of asthma, excluding the cardiac or renal air hangers, is exactly the same as those in which we get reactions. Probably the fault lies in our not having a sufficient list of proteins to try them with. There are many different proteins in a grain of wheat. I have six in my tests. Also think of the number of protein derivatives there are in the digestion of foods, the scores of microbes inhabiting the bowel, the hundreds of non-pathogenic organisms, many unnamed and unknown to us, but each with its specific protein to which we may be sensitive. There is also the question of a period of desensitization after attacks to be considered.

Chronic Anaphylaxis.

Danzysz, the French bacteriologist, has recently published a book which is creating considerable excitement amongst the few who have read his work on *Maladies Chroniques*.

He attributes to sensitization to intestinal microbes or other proteins, not only the attacks and exacerbations of chronic complaints from frequent anaphylactic upheavals, but states that the actual presence of antibody or our "digestive substance" in excess is the cause of our "chronic complaints. Fresh antigen may then precipitate big attacks of asthma, urticaria, and so forth, or may by smaller doses cause such complaints as psoriasis, eczema, neurasthenic and menstrual disorders or stomachic upsets.

It is necessary always to bear in mind the double poisoning of microbes and other substances, one in virtue of their toxins, the other in anaphylactic response to their protein content.

The following experimental work backs up Danysz's claim:

Rabbits are given doses of horse serum daily for two or three months with no ill effect. In this way a maximum quantity of the digestive substance is formed. Now if the animals be left for three months without any injections it is found that some will have paralysis, others skin troubles with alopecia, others arthritis, in fact at the end of a year they will nearly all be dead. They waste and in every way copy the chronic complaints that man is heir to.

How do Asthmatics become Sensitive?

In many there is a strong family history, not to the actual protein but to asthma and like diseases. A horse asthmatic father may have one child with hay fever, another with asthma and sensitive to potatoes and hen feathers. There is often a history of fever or inflammation of mucous membranes which has allowed the sensitizing protein to pass through.

Schloss's boy¹⁹ had albumen water for diarrhoea when only a few days old, when egg albumen can pass through the intestinal mucous membrane; this was his sensitizing dose. He next had his first spoonful of egg, the exciting dose, at fourteen months, and it nearly killed him.

The long-continued presence of a protein may make people sensitive to it. I have a patient who has been a baker for twenty years; he is now an asthmatic, very sensitive to wheat and oats.

We will now go over a case of asthma in the light of this new work.

More important than the age is the age of onset. The younger the patient the more simple the cause, the freer from bronchitis and bacterial infections or sensitizations. Ninety per cent. of children give reactions. But no matter what age the patient may be, the chance of finding the cause by the skin reactions increases in proportion to his youthfulness at his first attack. Patients 60 years of age will give reactions if they started their asthma in childhood; whereas in those commencing after 40 very few give reactions except clear cases of occupational sensitization, as the butcher and the baker. The chief points in the history are to know if the complaint is continuous or arises only at certain times of the year or in certain places. If the asthma is constant, have there ever been times when the patient has been free—on a sea voyage, for instance?

The family history merely denotes the predisposition and will not help us to the protein at fault. The pre-natal history will not help either, but is intensely interesting. Like everything else in asthma, it is completely paradoxical.

One patient's mother had seven children. Her husband was a horse asthmatic. With one child, a boy, she had eczema all the time she was pregnant; that boy is a horse and dog asthmatic, all the rest of the children being normal. Another lady has had asthma ever since she was married, very badly and always, excepting for nine months when she was pregnant. The child, a boy, is healthy. I have had a similar history with a migraine patient. Another lady had only had hay fever twice in her life, on both occasions during the whole summer that she was pregnant. One of her sons is a horse asthmatic, the other has had hay fever. Another patient, sensitive to milk, had to have chloroform and morphine every day and night during her two pregnancies. She did not nurse either child. One child was very ill for the first six weeks with gastric troubles after milk; the other, on milk also, died from asthma at 6 weeks of age. This was probably true transmission of sensitiveness to the offspring, as can be produced experimentally in animals. It soon passes off, as it did in the first child.

A history must be made of any distastes for special foods, of the animals present in the house, of microbial diseases, or of the effect, as known, of pollens. Next to the skin reactions, histories of treatment are interesting when seen in bulk. Every article that can be a cause of the asthma must be tested for. Too much reliance must not be placed on the history. One child was very ill in the country during the haymaking season, but better at the seaside. He was not sensitive to pollens, but to oats, etc. He had much oatmeal in the country, and none at the seaside. A complete physical examination must be made; one must not miss tuberculosis even if the reactions give the cause of the asthma.

There is often a history of colds that are said to cause the asthma. More often than not the sneezing and the catarrh is true asthma; certainly, in children, the asthma is often preceded by a year or more of colds and bronchitis. Exercise and dust will often bring on an attack, but they are not the cause. If one finds the cause, the mother will write to say: "It is so nice to see little Tommy running about with the other children and not getting asthma." If the cause can be discovered and it is one that can be removed, the patient will lose the asthma from that moment. Conversely, if the asthma does not go, the cause or all the causes have not been discovered.

There is not space to discuss, nor do we know, the actual mechanism whereby these various proteins act, but there would seem to be two types of patients—those whose mucous membranes respond as quickly as do skin reactions, a matter of minutes, and others whose attack comes some hours after meeting the protein to which they are sensitive, as in my cat case and in the "marchand de mouton." Lastly we must not forget the remarkable part played by the nose in asthma. Occasionally the nasal surgeon will cure patients for varying lengths of time by simply cauterizing the nasal mucous membrane.

Whether the smell of animals actually contains protein which enters with the breath, or whether some central nervous mechanism is set in motion directly through the olfactory nerve is still a matter for investigation. Very little work has been done in connexion with the sense of smell, but the mechanism is extraordinarily sensitive. Now, normal people in the presence of a horse must breathe in just as much of the smell or protein of the horse as these asthmatics. Is it simply that their blood is not sensitive to the horse protein? Or is the protein stopped at the mucous membrane of normal persons? Or does it get through, but is summarily dealt with in normal persons? Again, can this possibly have any bearing on the facies that stamps the ostler and the groom so unmistakably?

Starting with one drop of a 1 in 100,000 solution, I have produced a bad attack of asthma by reaching an overdose at 5 minims of a 1 in 10,000 solution. If the patient is sensitive to articles which cannot be avoided, that is, chiefly horse-hair or pollen, he can be desensitized to either by gradually increasing but very small doses, always controlled by skin reactions. Another treatment is that by the intravenous administration of peptone,²⁰ on the idea that all these proteins are broken up into peptones during digestion, and therefore the one peptone may, so to speak, catch them all at a lower level than the specific proteins. The third method is also a method of anti-anaphylaxis, but instead of using small doses of peptone, as antigen, mixtures of microbes from the ordinary intestinal flora are used hypodermically. This is the method of Danysz. He uses autogenous and heterogenous cultures of all the intestinal microbes that will grow on a sloped gelatine or peptone culture. They are used as antigens, not for any toxins they contain, but simply for their protein contents.

By these various methods most cases can be improved, some made gloriously well. The delicate child cooped up in a stuffy nursery each winter with the cat, the dog, or the feather bed that is causing all the trouble, becomes normal straight away. It is impossible to tell which case will give reactions, or which will improve under any particular method of treatment. The method of Danysz must be used with very careful dosage or big attacks of asthma may come on, the patient even being made worse for a time.

With regard to the treatment of disorders allied to asthma, still scantier claims must be made because of the small number of cases coming under any particular heading. The following case is of interest:

A gentleman, at one time a fine athlete, has suffered from neurasthenia and gastric disturbances since the war, feeling blown out after his meals, and in a condition that might well be called hypochondriacal. On testing he is found to be very sensitive to potatoes. Removing these from his diet has made him a different man.

The treatment of Danysz in some cases does give the extraordinary results claimed for it, especially in chronic eczema and other skin diseases. I am, however, convinced that we have yet much to learn in the dosage of these entero-antigens.

If we look back at our diagram and see that the size of the dose alone decides whether it shall be a sensitizing dose,

an exciting dose, or a curative dose, we may well be puzzled in finding the correct dose in a sensitive patient.

Summary.

1. By the skin reactions half the cases of asthma can be proved to be due to some foreign protein.
2. If these causes can then be removed the patients are relieved of their asthma at once.
3. Much can be done to relieve or even cure other cases which do not give positive skin reactions, by the usage of various proteins, as antigens, to desensitize them with.
4. Asthma, hay fever, urticaria, eczema, migraines, epilepsy, and paroxysmal haemoglobinuria, have many common traits and will probably all be proved eventually to be symptoms of anaphylaxis and not separate diseases at all. This list will most likely be considerably enlarged.

In conclusion I wish to thank those many gentlemen whose patients I have tested and treated, but especially my friend Dr. Latham, through whose interest my attention and work have been so fully turned to this matter.

This new advance in medicine may be only a matter of inches, but it does allow us to see round a fresh corner and to obtain a view, and a direct view, of great possibilities in connexion with these chronic complaints, the cause and cure of which have so long baffled explanation.

REFERENCES.

- ¹ Richet, *Anaphylaxis*, translated by Murray Bligh. ² Besredka, translated by Gloyne. ³ Danysz, *Maladies Chroniques*, 1920. ⁴ Hayman, *De Sanguis des altérations anatomiques*, 1889. ⁵ Longcope, International Congress, London, August 11th, 1915. ⁶ Lewis, *Journ. Amer. Med. Assoc.*, February 1st, 1919. ⁷ Freeman, *Lancet*, September 16th, 1911. ⁸ Goodale, *Boston Med. and Surg. Journ.*, 1916; Talbot, *N. Y. State Journ. of Med.*, 1915; Chandler Walker, *Journ. Med. Research*, 1917, and some sixteen other papers; Wodehouse, *Journ. of Immunology*, 1917, etc.; Freeman, *Lancet*, 1920. ⁹ Ramirez, *Journ. Amer. Med. Assoc.*, September 27th, 1919. ¹⁰ Pagniez, *Presse Médicale*, February 23rd, 1916. ¹¹ Vidal, etc., *Presse Médicale*, February 4th, 1920. ¹² Cordier, *Journ. de Lyon*, 1920, p. 113. ¹³ Skin Reaction in Eczema, *Arch. Dermat. (American)*, 1920, p. 531. ¹⁴ Sutton, *Journ. Amer. Med. Assoc.*, vol. 73, p. 1434. ¹⁵ *Presse Médicale*, 1914, p. 525. ¹⁶ Cowie and Colhoun, *Arch. Intern. Med.*, January, 1919. ¹⁷ Moschowitz, *New York Med. Journ.*, January 7th, 1911. ¹⁸ *Semaine Médicale*, 1915, p. 613. ¹⁹ Schloss, *Journ. Dis. Children*, 1912, 341, iii. ²⁰ Auld, *BRITISH MEDICAL JOURNAL*, 1917, i, p. 580. ²¹ Pagniez, *Presse Médicale*, November 19th, 1919. ²² Vidal, *Presse Médicale*, July 11th, 1914.

CHRONIC RETENTION OF URINE ARISING FROM PROSTATIC DISORDER:

ITS CAUSE, AND TREATMENT BY THE PRACTITIONER WITHOUT OPERATION.

BY

HERBERT T. HERRING, M.B., B.S.,

LONDON.

CHRONIC retention of urine is most commonly produced by some disorder of the prostate gland, and among these troubles enlargement is that most frequently met with. Retention therefrom was generally attributed to a pure mechanical cause, that is, the urethra was blocked or plugged by the intervention of a mass of abnormal gland tissue, which was thrust into the orifice during micturition, thus preventing the escape of urine. Many mechanical theories, based on this principle, have been advanced. At one time it was a large middle lobe which dropped into the orifice like a ball valve. At another it was side-flaps springing from the neck, which met together in the middle line like flood-gates. At a third it was the regular enlargement of the glands round the orifice which prolonged the urethra as a solid projection into the vesical cavity and prevented the escape of fluid, much as an excise-man's inkstand does when upset. And finally, the post-prostatic bar was accused of causing the mischief, for it was said that the bar came forward over the outlet during vesical contraction and effectually blocked it, while at the same time the pressure produced a deep pocket or pouch behind the prostate. None of these explanations appear to be entirely satisfactory. For their supposed action is not supported by the facts disclosed during the use of a catheter; neither do they account for many of the symptoms frequently met with; and finally, the removal of the irregularities—valves, flaps, nipples, bars, etc.—does not invariably restore the lost function. The whole prostatic tissue must be enucleated to ensure success. It would seem, therefore, that although mechanical obstruction may assist, it is not the principal cause of retention.

Before giving yet another explanation, on a different line, a brief sketch of the various pressures existing in the bladder and urethra is necessary to make the argument clear.

Urine within the bladder, when the organ is quiescent, is always subjected to pressure—namely, that due to the force exerted by muscle tone, and to that of the weight of the viscera above. For convenience these two forces are considered as one, and may be termed "tonal bladder pressure." It is found that this tonal pressure increases as the bladder fills—thus, for instance, when empty the pressure may register 15 mm. of mercury, but when holding 10 ounces of urine it may have risen to 30 mm.

The escape of urine is prevented by the resistance the prostatic urethra offers to dilatation. The channel is always tightly closed, and is only open when the pressure on the urine in the bladder exceeds its power of resistance. It therefore follows that as urine does not escape until the act of micturition—that is to say, not until a muscular contraction is evoked—this prostatic resistance must always be greater than the maximum tonal pressure, and if the latter is known by experiment, then the pressure of prostatic resistance must be in excess of that figure. The resistance throughout the length of the prostatic urethra is not equally distributed: it is least at the commencement and increases gradually towards the apex of the gland, where it is the greatest. The total resistance of the whole passage may be said very roughly to be between 40 and 50 mm. of Hg, and it is possible that its maximum is attained with an empty bladder, decreasing slightly as the organ is distended.

When the rise of the tonal pressure, due to the gradual filling of the bladder, approaches that exercised by the prostatic resistance, urine begins to make its way into the first part of the prostatic urethra, which then becomes an integral part of the bladder. As the invasion advances the reflex centre controlling the muscular power of the bladder is stimulated, and the desire to micturate is induced. Should the call be inconvenient, extra resistance is immediately imposed on the urethra by the contraction of the various bands of voluntary muscle distributed around the passage and also by the compressor urethrae muscle. The augmented opposition to the pressure in the bladder, and possibly the expulsion of the urine which has invaded the passage, checks the escape, and the slight wave of contraction which has swept over the bladder wall slowly dies away and with it the desire to micturate. If, on the other hand, the call is complied with, the muscular bladder wall is thrown into contraction, the prostatic resistance is overcome and the urine issues in a steady stream. During the act the voluntary muscles, if desired, may be called into play, so that more resistance is interposed; the stream then lessens, and finally stops, and urine is voluntarily left behind in the bladder. The muscular expulsive power of the bladder is found to behave similarly to that of the tonal pressure, for it is strongest when the bladder is full, and falls as it empties, but it differs in that it ceases directly evacuation is complete. The expulsive force, for instance, with 10 oz. of urine in the bladder may record 180 mm. of Hg pressure, but with 5 oz. it has fallen to 50 mm. or less, and with an empty organ there is none, only that of the tonal pressure of 15 mm. being registered. Further, under normal conditions the whole power the vesical muscle is capable of developing is not invariably called forth, the amount generated being tempered to the work that has to be accomplished, and normally there is always a good margin of reserve power.

The act of micturition is therefore effected, first, by the steady rise of the tonal pressure as the bladder fills, which gradually forces urine into a portion of the prostatic urethra, there stimulating the area governing the bladder muscles; secondly, by the contraction of this bladder muscle, which develops sufficient power to overcome the prostatic resistance.

Normally the two forces—bladder expulsive power and prostatic resistance—are so balanced that they allow of the complete evacuation of the bladder and nothing more. If, however, the balance is disturbed, as is frequently the case in disease, disorder of the act of micturition must follow. Thus, if the prostatic resistance is increased, the expulsive power remaining the same, then a point will be reached during evacuation and before the bladder is empty

at which no more urine can be thrown out, and residual urine is the result.

Again, it is obvious that if the resistance exceeds or is equal to the maximum expulsive power the bladder is capable of exerting, total retention will follow and no urine can be passed naturally. On the other hand, if the resistance is diminished below the normal, then the bladder capacity will be smaller, and the patient will pass urine more frequently but in smaller quantities.

That prostatic resistance is generally augmented by enlargement is amply proved, not only by clinical investigation of the canal and by the fact that removal of the whole tissue restores the lost power, but also by the anatomical and pathological features the gland presents. The prostate is surrounded laterally and below by a very strong fascial capsule. This space is filled with simple and compound racemose glands lying in a groundwork composed of elastic, fibrous, and muscular tissue. Any glandular growth will tend therefore to advance along the line of least resistance—namely, towards the lumen of the bladder, but at the same time will press upon the urethra, which pierces the mass centrally, and will consequently offer increased resistance to any dilatation.

For the foregoing reasons it is contended that retention from prostatic disorder is mainly caused by increased prostatic resistance, and not so much by mechanical blocking as was formerly suggested.

Treatment of Retention caused by Increased Prostatic Resistance.

The tendency at present is to operate on all cases in which retention has declared itself, and to operate early before any routine treatment has been tried. For it is urged (1) that the disease is progressive and cannot be arrested; (2) that the kidneys are subject to back-pressure, which ultimately produces renal inefficiency and degeneration; (3) that the habitual use of the catheter invariably leads to sepsis, with local and general complications.

In reply to these arguments, it may be said that although the prostatic tissue may continue to grow, it does not follow that the resistance increases in the same proportion, and if it does, the resistance may be combated by a corresponding development of the bladder expulsive power (compensation); that there never can be any back-pressure if the catheter is properly and systematically used; and that the occurrence of sepsis is nothing more than the frank acknowledgement of a breakdown in the technique adopted with regard to the preparation and passing of the catheter.

In dealing with prostatic retention it would seem advisable first, if possible, to effect a cure, or an amelioration of the symptoms by treatment, and afterwards should this course fail or catheter life be too great a tax on the patient, then to resort to operation. The time lost will have no bad effect, in fact very often the reverse, and perhaps happily the patient may then escape the trouble of a severe ordeal.

The treatment of retention due to increased prostatic resistance should be directed to two main objects: first, to reduce that resistance, and secondly, to increase the expulsive power of the bladder.

No marked success, as a general rule, attends the treatment of the prostate alone, except in a limited number of cases, where the trouble arises either from congestion, possibly brought about by straining during the too frequent act of micturition, or from the pent up glandular secretion owing to the blocking of the slender prostatic ducts by debris or small calculi. Improvement may then be attained by appropriate massage applied directly to the prostate itself, the fluids are dispersed or expressed, slight shrinkage of the prostate follows, with a corresponding alleviation of the symptom. More, however, may be expected from a combination of this with treatment undertaken to restore or increase the muscular expulsive power. The procedure may be illustrated by describing a typical case. A patient complains of obvious and definite symptoms of prostatic enlargement accompanied by chronic retention. The urine is clear and healthy, and the prostate on rectal examination is found to be full and elastic. On introducing a catheter, immediately after he has passed all he can by his own efforts, 10 oz. of urine are withdrawn. The effect produced by the constant presence of this amount of fluid in the bladder is similar to that of a limb

subjected to continuous weight extension. It relaxes and loses its power; the loss and exhaustion in the bladder is accentuated by its struggle to expel a fluid against a resistance it cannot overcome. The amount of residual urine, if allowed to remain, tends to increase independently of any further increase in the prostatic resistance. It is evident, if any amelioration of the condition is to be effected, that the bladder must be artificially relieved of its load, and the catheter should be used certainly twice, if not three times, in twenty four hours at regular intervals.

Under this treatment the symptoms disappear, and in the course of a few days the average residual urine falls from 10 to 7 or 8 ounces, but the quantity then remains stationary. The catheter has thus far restored some of the expulsive force, but will do nothing more, probably the reverse in the future, unless it is aided by some other means. For the urine is expressed from the bladder during catheterization only by the tonal pressure, and not by any muscular contraction. The muscle during the emptying remains idle, never being called upon to exert itself, and with such inaction, or with only passive movement, it soon begins to lose its power and become inoperative. To counter this defect, and to cope with the increased prostatic resistance, it is necessary not only to maintain the existing power by exercise, but also to develop muscle strength—that is, to produce compensation by hypertrophy. The line of treatment indicated is to induce the desire to micturate while the catheter is *in situ*. The urine is then expelled in a more rapid stream through the catheter, and probably at its side through the urethra, by the gentle muscular contraction, and not by tonal pressure alone, and thus the muscle is efficiently exercised.

This treatment must be repeated regularly and for a considerable period; the residual urine will gradually diminish, from 8 to 5 and from 5 to 2 ounces, and in quite successful cases total natural evacuation will result. There are, however, one or two details to which attention must be paid. In the first place it is not always easy to induce muscular contraction while the catheter is being used. The patient feels "no desire," and cannot evoke it. The best plan then is to pass the instrument when the bladder is full—that is, when it contains not only the residual urine, but also the amount he is able to void naturally. The desire then becomes almost spontaneous. Again, as the muscle grows in strength, more and more work must be imposed upon it, though it should never be overtaxed or exhausted. A catheter of a smaller internal bore than the original should be substituted, or the catheter should be drawn slightly into the prostatic urethra and the eye partly blocked. In both cases increase of flow of urine by the side of the catheter will follow. It is found, moreover, that a catheter, or "continuous" tube, is not absolutely essential to withdraw the residual urine when muscular contraction is induced; a solid instrument of No. 6 or 7, especially if grooved on its surface) traversing the prostatic urethra will suffice, for it separates the passage walls and leaves a chink above and below it through which the urine will escape during vesical contraction.

CONCLUSIONS.

The objects, therefore, of instrumental treatment of a case of retention from prostatic enlargement are:

1. To preserve intact the activity of the existing muscle by exercise.
2. To prevent the exhaustion which might necessarily follow an ineffectual struggle, by the use of the catheter.
3. To artificially reduce the prostatic resistance while the patient is under treatment so that the bladder may be emptied by muscular contraction.
4. To develop the muscle by gradually increasing its work as it gains strength, so that ultimately the expulsive bladder power may be able to deal with the increased prostatic resistance without the aid of artificial means.

The success or failure of the treatment, however, must largely depend on the maintenance of the urine in a condition of sterility. Too much stress cannot be laid on this point. Nothing short of boiling both instrument and lubricant is of any avail. Chemical antiseptics are useless; but with this precaution, coupled with manual dexterity, an aseptic state may be maintained for an indefinite period.

RENAL DECAPSULATION FOR CHRONIC
PARENCHYMATOUS NEPHRITIS.*

BY

FRANK KIDD, M.B., F.R.C.S.,

LONDON HOSPITAL.

In the early years of the present century this subject was "in the air," as a result of the writings of Edebohls of New York. At that time I was able to observe the results of stripping the capsule of the kidney in several cases of chronic nephritis. For some reason or other the results were not promising, and when one came to consider Edebohls's book, many of the cases quoted in the book did not appear to fit in with the conception of chronic nephritis as usually understood in England. At that time, therefore, I came to the conclusion that there was very little promise in stripping the kidneys for chronic nephritis.

In 1916 I had my attention called to this subject by the fact that I was called in to see the children of two doctors suffering from chronic nephritis. The doctors urged me to strip the kidneys. Not having had favourable experience of this measure I could not accede to this request, but I began to look up the recent literature again, and noted that favourable cases had been reported from time to time. I asked some of my medical colleagues to allow me to try the operation once more upon patients at the London Hospital. As a result, Dr. Lewis Smith and Dr. Hadley sent me the first case I report below. He had been ill for a very long time, was completely waterlogged, and medical treatment seemed to offer him no further hope. Soon after the operation I went away in the army and lost sight of the patient. He turned up in 1919 quite restored to health and able to do a full day's work.

I was so impressed with this that I asked Dr. Hadley to send me some more cases; the last three I report below. The results were that one appears already to be well, another improved for a time but relapsed, and shortly afterwards died of tuberculosis of the lungs and uraemia. The fourth lost all his signs and symptoms for a short time, but has since relapsed.

I think these results, taken in conjunction with Sir Thomas Horder's cases, justify an appeal to the profession to reconsider this subject, as it is clear that some cases of chronic nephritis are greatly benefited and may even be cured by the comparatively harmless process of stripping the capsules of both kidneys.

When we have a sufficient number of cases for review I think we shall be able to pick out a type case in which the result is likely to be beneficial. At present it does not seem possible to state which case the operation is going to benefit and which not. Sir Thomas Horder suggests that it is the case without cardio-vascular change that will benefit from the operation, but I do not yet feel convinced of that. Two of my patients had a high blood pressure and two a low blood pressure, and yet the result was quite good in one of the patients with high blood pressure. Of course, in this case, the raised blood pressure may only have been a temporary phenomenon, and it may be that no permanent changes had taken place in the heart or in the blood vessels. Still, I feel that there is something more we have got to find out to enable us to distinguish the type of case suitable for the operation. One favourable case had polyuria, and one had oliguria.

EFFECT OF DECAPSULATION.

How does stripping the capsule have a beneficial action? I cannot believe that it has anything to do with the relief of tension, because when one strips the capsule in these cases the kidney does not seem to be under any tension—that is to say, it does not expand; nor does the capsule appear to be capable of a great resistance to tension. We know how easily the capsule can stretch in cases of acute pyelonephritis. In such cases the kidney will suddenly swell up to two or three times its normal size, and return to the normal size again in a fortnight or less, so that the capsule must be easily distensible. I do not think it can be due to a permanent increase in the blood supply of the

kidney, because the favourable changes seem to appear within a few hours, or at most within a few days.

Personally I believe that by removing the capsule of the kidney we unblock the lymphatics and set up another route for the lymph to flow out of the kidney. The lymphatics of the kidney run up from the ureter under the capsule through the kidney, where they receive the lymph of the kidney substance, and then to the glands in the vascular pedicle of the kidney. The capsule seems to act as a membrane to shut off lymph from the perinephric fatty tissue. Possibly in these cases of chronic nephritis the lymphatics become blocked either by excess of lymph or by fibrinous deposit, and the nephritic poison cannot be drained away from the kidney substance. I have noticed that directly after stripping off the capsule of these kidneys, clear lymph seems to flow out from the kidney sponge almost at once—the kidney seems to ooze lymph. This lymph may then be picked up by the tissue spaces of the perinephric fat and be absorbed by another route.

Technique of Operation.

As regards the details of the operation, I always operate on the kidney with the patient in the face-down position, as recommended by Edebohls. In this position the patient breathes much better, and it is possible to expose both kidneys without moving the patient. There is no need whatever to bring the kidneys up to the surface; I simply cut down to the surface of the kidney, make a snick in the capsule and strip it off with the fingers, and leave it all bunched together round the hilum. I put in a tube for twenty-four hours. In this way I did both kidneys in twenty-three minutes in one patient and twenty-two minutes in another patient. I think it is of advantage to operate as quickly as possible, as one does not want to expose the patient for a long period to an additional kidney poison, such as ether or chloroform. One of the patients was so dyspnoeic that he could not lie down at all. The anaesthetic was administered sitting up, and when he was "under" he was placed in the face-down position and we found his breathing was good enough to proceed. The same evening the patient could lie down in bed and within a few days his dyspnoea had entirely disappeared.

SUMMARY OF CASES.

I give a summary of the four cases in which I have tried this procedure. I hoped to have operated on some more cases before I reported them, but I thought that this was a favourable opportunity to bring forward the work I had already done, in the hopes of encouraging further research on this subject.

CASE I.

Male, aged 14 years. Admitted, June 9th, 1915, to the London Hospital, under the care of Drs. Hadley and Lewis Smith. Has never had scarlet fever. Sudden onset of present illness a few days previously. Complaints of severe headaches and vomits intermittently. General oedema, extreme pallor; oliguria very pronounced, as little as 6 ounces of urine passed in twenty-four hours. Urine: Solid with albumin; specific gravity 1045; casts; no blood. Systolic blood pressure 120 mm. of mercury.

Shortly after admission had fever lasting a week, highest temperature 103° F. After ten weeks in bed on the usual medical treatment he showed evidence of improvement, and went out with very slight oedema of legs and a trace of albumin in the urine.

Relapsed March, 1916, after a chill. Readmitted June 8th, 1916. General oedema and pallor. Urine: Oliguria—8 to 12 oz. a day; solid with albumin. Systolic blood pressure remained at 115 to 120 mm. of mercury. Up to September 27th no improvement at all on usual treatment. No real dyspnoea.

September 28th: Operation under open ether. The right kidney stripped *in situ*. The kidney appeared moderately enlarged, paler than normal; it bled too freely, and was friable. The capsule stripped easily. No evidence of fibrosis. A rubber drain left in for a few days. October 25th: Left kidney stripped. November 1st: Urine $\frac{1}{2}$ albumin. November 14th: Urine $\frac{1}{2}$ albumin. Left hospital improved but by no means cured.

Seen again on May 1st, 1919. Appears to be in perfect health. Able to do a full day's work. Urine: Specific gravity 1010; a trace of albumin. No oedema, no pallor. Blood pressure normal.

When seen again on November 13th, 1919, was perfectly well.

CASE II.

Male, aged 27 years. Admitted to the London Hospital under the care of Dr. Hadley March 4th, 1920. Eight months previously attended Brompton Hospital for tuberculosis of the lungs; discharged improved in October, 1919. November, 1919, submucous resection of nasal septum performed. December, 1919, general oedema and pallor.

On admission general oedema and ascites, dyspnoea, anaemia, and pallor; no fever; frequent vomiting. Urine: Albumin $\frac{1}{2}$ to $\frac{1}{2}$; casts; blood; polyuria, 70 to 90 oz. a day; specific gravity 1011, urea 1.1 per cent. Optic discs blurred. Systolic blood pressure 175 to 180 mm. of mercury. The apex beat was in the nipple line in the fifth space.

* Contributed to the Urological Section of the Royal Society of Medicine, October 28th, 1920, following Sir Thomas Horder's paper on the same subject (BRITISH MEDICAL JOURNAL, November 13th, 1920, p. 727).

April 4th, 1920: Getting rapidly worse; orthopnoea; oedema of lungs; cannot lie down at all, and has to be nursed in a chair. On April 12th I persuaded Dr. Whyte, a resident, to administer ether to the patient in the upright position. As soon as the patient was "under" he was placed on his face over an air-bag, in which position he was able to breathe sufficiently well for me to proceed with the operation. I stripped both kidneys in twenty-four minutes from the first cut to the last stitch. There was advanced oedema of the perirenal fat. The capsule was thin and friable, and very adherent to the kidney substance, and stripped badly. There was no shock, and the same night the patient was able to sleep quietly lying on his back, propped up by pillows. In a few days the oedema had much diminished and the dyspnoea had disappeared. The improvement was only maintained for a few weeks, and then the symptoms returned again, though the dyspnoea did not become so bad.

He went to the infirmary, where he died of phthisis and uraemia on September 6th, 1920. There was no *post-mortem* examination.

CASE III.

Male, aged 18 years. Admitted to the London Hospital under the care of Dr. Hadley, June, 1920, with a history of six months' general oedema and pallor, and headaches.

On admission, general oedema, pallor. Urine: Albumin $\frac{1}{2}$; casts; polyuria, as much as 90 oz. in twenty-four hours. Systolic blood pressure 170 to 180 mm. of mercury.

Operation July 22nd, 1920. Dr. Whyte administered open ether. I stripped the right kidney in thirteen minutes, the left in nine minutes. Capsule stripped easily. Kidneys enlarged, pale and mottled and fatty. No oedema of perirenal fat. Lymph oozed out of kidney on stripping. Portion removed for section.

The patient improved at once. In October, 1920, he was able to go about and looked upon himself as well. There is, however, still a little albuminuria, and the legs swell very slightly at times.

CASE IV.

Male, aged 20 years. Admitted to the London Hospital July, 1920, under Dr. Hadley, with a history of general oedema since six weeks before admission.

On admission, general oedema, pallor not marked; no vomiting; no fever; no headache. Urine: Solid with albumin; specific gravity 1020-1025; oliguria, 18 to 32 oz. in twenty-four hours. Systolic blood pressure 130 mm. of mercury. No improvement after five weeks' medical treatment.

Operation on July 22nd, 1920. Dr. Probyn Williams administered ether. Each kidney stripped in eleven minutes. Fluid poured out of perirenal fat. Capsule thickened, stripped badly, and tore pieces of kidney out. Marked fibrosis. Kidneys not enlarged; capsule pale because of the oedema of capsule itself; the cortex appeared to show areas of fatty degenerations, but was not diffusely and completely degenerated as in the other cases.

Three weeks later the oedema had disappeared, the urine had increased to normal amount, and the albumin had diminished. The patient was getting up in September, but then got chilled when sitting about the ward, and relapsed.

RECONSTRUCTIVE ANEURYSMORRHAPHY IN THE THIRD PART OF THE AXILLARY ARTERY.

BY

C. JENNINGS MARSHALL, M.S., M.D., F.R.C.S.,

ASSISTANT SURGEON AND ORTHOPAEDIST, KING'S COLLEGE HOSPITAL;
SURGEON, MANOR HOUSE HOSPITAL.

A MAN, aged 25, wounded in March, 1918, was, after three months in hospital and *dépôt*, returned to his unit. He was demobilized in 1919, and resumed his occupation as a baker. At that period he had, at most, occasional aching in the axilla. In February, 1920, he noticed a swelling in the armpit which increased slowly in size; it was accompanied by a feeling of heaviness in the left upper limb after use. After a short time he began to experience pain radiating down to the index and middle fingers and to lose power in the index. After six months' delay he was admitted to the Manor House Hospital.

It was seen that the patient had sustained a through-and-through bullet wound of the left axilla. A fine scar above the lower margin of the pectoralis major one inch and a half from its insertion indicated the entry, and a slightly larger one a little outside the inferior angle of the scapula the exit. In the line of the artery was an aneurysm the size of a large walnut, its upper third lying under cover of the anterior axillary fold. The expansion was forcible, but not great in extent; the tumour could not be emptied by pressure owing to the pain referred to the index. There was no venous hum. The adjacent tissues were not thickened—the tumour was quite discrete—very little inflammation or effusion had evidently accom-

panied the wound. There was slightly impaired sensation of the ends of the index and middle fingers; flexion of the index was very weak. The peripheral circulation of the limb did not differ from that on the other side.

Operation.

Open ether was administered by Dr. Bookey, and Mr. A. E. Woodall, F.R.C.S. (resident surgeon), assisted.

The arm was fully abducted, and an incision four inches long was made in the line of the artery, its centre over the aneurysm, and its upper end curving inwards towards the chest wall. The deep fascia was divided to the full extent of the wound, and the axillary artery was exposed one inch above the upper limit of the aneurysm; the minimum amount of dissection was done to permit the application of a Crile's artery clamp at this spot. The vessel was then treated similarly below the sac; the two

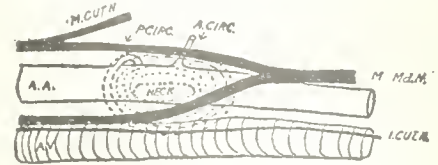

clamps lay above the anterior circumflex and the profunda artery respectively. The aneurysm was next defined by sharp dissection. Only at the lower and inner part was there any difficulty; elsewhere the tumour required only a few touches of the knife to free it. When the vein had been separated at the lower and inner part it was seen that the inner head of the median was bound to the aneurysm by dense fibrous tissue; when this was divided, however, the nerve showed no break of continuity. The sac was then defused up to its point of origin from the artery, to which it was moderately adherent up to its neck, and then opened by a longitudinal incision. At once it became apparent that the collaterals needed control. The branches arising between the clamps were quickly defined by blunt dissection, the flow from the sac being checked by pressure, and a clamp placed to include them; very slight pressure secured complete haemostasis. The

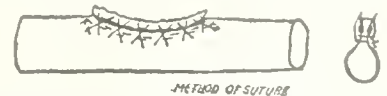

opening from the artery was oval ($\frac{3}{4}$ in. by $\frac{1}{2}$ in.); at the junction of vessel and sac there was a ring of almost cartilaginous density, as became evident later on an attempt to pass the needle at this spot. The sac, which was free from clot, had the thickness of blotting paper; its interior looked smooth and shiny everywhere. Two branches had been clamped—the posterior circumflex just above the level of the opening, and the anterior at its lowest level, each at a part of the artery opposite to the opening into the aneurysm. A test was made to determine the relative importance of these in the collateral circulation. With the posterior vessel clamped the flow from the anterior was the feeblest possible trickle. That from the posterior was considerable, steady, and in quantity about equal to that from a radial vein.

It was estimated that to suture the edges of the opening, allowing for a fair depth of apposition of the intima, would diminish the diameter of the vessel, compared with the part above, to about two-thirds, which seemed adequate. The sac was therefore cut away, leaving only a thin rim round the neck. The whole area was kept moist by normal saline. With a non-cutting fine needle a continuous suture was introduced, beginning above and finishing below the opening, passing through the arterial wall immediately adjoining the thick ring; the stitching was mattress in type, every other stitch returned slightly to give a locking effect. The material was very fine silk.

The clamp on the collaterals was then released and fairly free oozing occurred, the fineness of the silk having prevented any but the slightest tension in approximation. The clamp was again tightened and a stronger silk suture was introduced, the needle traversing the artery wall on either side and returning similarly through the rim of sac, thus embracing the hard ring and securing apposition of

its opposite sides. For further safety these stitches were made to cross in pairs. The clamps were released in order, first from the branches, then the distal, then the proximal, and, as the severest test, the distal clamp was tightened again. There was not the slightest oozing. In view of the exposure of the site of suture to strain, a graft of fascia lata was fixed as a collar round the vessel at this point, with its fibres transverse to the line of the artery, and with slits to allow the passage of the circumflexes. Above and below a loose stitch in the fascia near by prevented telescoping. The wound was then closed and dressed with gauze wet with 1 in 2,000 flavine. At the close of the operation the radial pulses were equal.

After-History.

Convalescence was uneventful. There was pain referred to the index and middle fingers for three days. The wound healed by first intention, and physiotherapy appropriate to the nerve condition and to the axillary scar was adopted from the twelfth day.

Three months later there was no sign of yielding; at the site of the suture was a thickening due to the presence of the graft. The brachial pulses were equal and the index showed almost complete recovery. Pulsation, though slight, indicated that thrombosis and obliteration of the artery had not occurred at the point of suture.

FRACTURE OF FEMUR: A SIMPLE METHOD OF EXTENSION.

BY

B. F. PENDRED, M.R.C.S., L.R.C.P.,

LOUGHTON, ESSEX.

FRACTURE of the femur in private practice is always looked upon with apprehension, and even in hospital work with some degree of anxiety.

One great reason for this attitude is the necessity for having a complicated apparatus made up of iron framework, a mast and guy-ropes, all requiring frequent adjustment and refitting, to the pain and distress of the patient. This, perhaps, may not be true of fractures below the middle of the shaft, as in these cases fair results may be obtained by use of foot extension with the limb lying straight along the bed.

The method I am about to advocate is for fractures above the middle, where the upper fragment is flexed forwards. As this fragment is too short to be maintained in any other position than that allowed by the muscles attached to it, it becomes necessary for the lower fragment to be brought into line with the upper, at the same time keeping up extension in that line. In such a case the patient is placed in bed on his back, the head and shoulders being supported by two or three pillows. The knee of the injured limb is raised until the femur is at the required angle, which is generally about 30 to 40 degrees to the horizon. It is maintained in this position with a knee pillow, or better still by a pyramid of sand-bags. A ring-shaped air-cushion is slipped over the foot, drawn up to the knee and inflated as fully as possible, the foot being allowed to fall back on the bed. A strong bandage is tied round the air-cushion exactly opposite the knee and the other end carried to a pole or mast fitted to the foot of the bed; strong traction is made in the line of the upper fragment, lower fragment, diameter of cushion, bandage and point on mast, until the ring becomes definitely oval, when the bandage is fixed to the mast. It will be seen that the extension is procured by a pneumatic pad in the flexure of the knee, and that the strain is transmitted to the femur through the head of the tibia and the ligaments of the knee-joint. These being rigid structures serve the purpose well.

Pneumatic pressure at the point indicated is justifiable, because all the great nerves and blood vessels dip deeply here under the heads of origin of the gastrocnemii, which being massive and fibrous in this situation are well adapted to support continuous pressure and protect underlying structures.

The advantages attendant on this method are:

1. Simple apparatus. A few pillows, a long piece of stick, a bandage and a ring air-cushion or inner tube of a motor tyre. Such things can be obtained almost anywhere at very short

notice, and there is no need to keep apparatus of various sizes in stock.

2. Ease of application. No skilled assistance required.

3. Once fixed adjustment is very seldom required. The bed-clothes are arranged so that the ring-cushion is uncovered and visible, a glance at its shape informs one immediately of the degree of tension and inflation.

4. The foot hanging over the pneumatic pad acts as a kind of rudder and prevents rotation of the lower fragment, or if desired it can be pushed inwards or outwards, rotating the lower fragment in any required direction.

5. There being no pulleys, guy-ropes, weights, or iron frame, there is very little necessity for disturbing the patient, which saves much anxiety and suffering. A bed slipper is easily adjusted.

6. The thigh is supported underneath by sand-bags, and others may be used at the sides if required to give a sense of security, but these are not necessary. The thigh can therefore be fully exposed, permitting easy examination, dressing or massage of suitable type, all without any disturbance of the fragments whatever.

I have treated only one case by this method:

A boy, aged 10 years, sustained a simple fracture of the right femur above the middle of the shaft. He remained in the apparatus for four weeks with the very slightest adjustments. At the end of that time, union being quite strong, the limb was removed from all restraint. At first any attempt to straighten the limb caused pain in the knee joint, but full flexion and extension returned without assistance within forty-eight hours. The only evidence of pressure by the pneumatic pad was a very superficial blister, which no doubt would have been obviated by binding lint over the rubber before application. The shortening was under a quarter of an inch. At no time was there any numbness, tingling, or oedema of the leg or foot.

The extreme simplicity and efficiency of this method, as compared with many devices advocated, are my excuse for seeking publication.

AN UNUSUAL CASE OF MYELOCELE.

BY

A. J. COKKINIS, M.B., B.S. LOND., F.R.C.S. ENG.,

ILFORD.

IN practically all the standard textbooks myelocoele is stated to be incompatible with life, the infant being either stillborn, or dying within a day or two. Bland-Sutton holds a somewhat different view. He states:

"Many children in which this condition is present are still-born: the few that survive their birth rarely live longer than three days, the continual leakage of cerebro-spinal fluid being sufficient to explain the invariable brevity of their lives." (*Tumours: Innocent and Malignant*. 1917.)

He thus admits the possibility of survival beyond the first day or two.

In inquiries, admittedly limited, which I have made on this subject, I have been unable to trace a single case in which the duration of life exceeded a period of three days. I have therefore thought that the following case, in which life was prolonged for twenty-three days, merited publication.

I was called to see the patient, a male infant, an hour after its birth, at the Ilford Maternity Home, during the early hours of September 18th, 1920. The reason for the early call was that the infant seemed very feeble and had difficulty in breathing. On arrival I found a well-nourished, good-sized baby, which soon revived and cried lustily. He had a well-shaped head, with no evidence of hydrocephalus.

The lower limbs were held rigidly flexed to a right angle at the hips, and rigidly and completely extended at the knees. The legs resisted straightening, and were paralysed, wasted, and, as far as could be made out, anaesthetic. There was double talipes equino-varus, the varus element markedly predominating, with a well-marked crease on the soles, corresponding to the transverse tarsal joint.

Looking at the back, there was a large, raw, circular area, somewhat depressed, and corresponding to a deficiency in the neural arches and failure of closure of the neural groove, opposite the lower three lumbar and upper two sacral bodies. The open spinal cord was seen in the middle line at the upper part of the defect, while the nerves of the cauda equina could be distinguished in the lower part. The myelocoele narrowed and deepened as it was traced upwards into the funnel-shaped termination of the central canal. Cerebro-spinal fluid was constantly, though slowly, dripping out of the apical opening, bathing the raw area, and then running in drops over the buttocks. The surrounding skin was rendered as far as possible aseptic, and a dressing applied. The next day the flow of cerebro-spinal fluid was freer, and some congestion developed round the myelocoele. During the first week the child's condition remained good. The raw area gradually contracted down and became deeper, while the inflammatory redness subsided.

The child now passed temporarily out of my care, being transferred to the Ilford Isolation Hospital. Here it was kept for several days, during which its condition was reported to be quite satisfactory. It was then sent back to the mother. When the child was over a fortnight old the mother naturally began to doubt the soundness of my prognosis, which had already been belied by the child living as many weeks as I had assured her was his maximum expectation of days. She expressed herself anxious for further advice, and I was making arrangements for the infant to be seen by Mr. W. H. Clayton Greene, when, during the third week, meningitis set in, and the little one died on October 11th in a storm of convulsions. It was thus twenty-three days old on the date of its death. Owing to the fact that both mother and child left the district a few days before the latter's death I was unable to witness the end. For the information about the date and manner of the infant's death I am indebted to Miss Roberts, the matron of the Maternity Home, who obtained it in a personal interview with the mother.

Another point arising in connexion with this case is the frequency of myelocoele when compared with the other types of spina bifida. Sir John Bland-Sutton is quoted by many authors as stating that myelocoele is the commonest variety of spina bifida; he admits, however, that of all cases that survive birth probably two-thirds are meningo-myelocoeles. Of the seven cases of spina bifida of which I have personal knowledge the one here described is the only case of myelocoele; one was a meningocele, one a spina bifida occulta, and the remaining four were diagnosed as meningo-myelocoeles. I have yet to see my first case of syringo-myelocoele.

In reference to the frequency of spina bifida in general practice the experience of a local practitioner of thirty years' standing is instructive. He has met with but two cases during this period in a practice which, to my knowledge, is exceptionally busy.

THE ACTION OF THE INTRINSIC MUSCLES OF THE FOOT AND THEIR TREATMENT BY ELECTRICITY.

BY

G. MURRAY LEVICK, M.R.C.S., L.R.C.P.,
ELECTROLOGIST TO ST. THOMAS'S HOSPITAL.

MOST of the intrinsic muscles of the foot and the long flexors of the toes play important parts that do not seem to have been recorded. The flexors of the toes raise the longitudinal arch of the foot, because when the weight of the body is thrown forward, as the heel leaves the ground in walking, their action is to draw the heel towards the toes, acting as bowstrings across the arch from heel to toe. For this reason the correct way to land from a jump is to have the whole weight of the body borne between the balls of the feet and ends of the toes, and, when patients are doing this or being given heel raising exercises in the standing position, they should be told to "grasp the floor with the toes," which thus become the fixed points from which their flexors act.

Flexor brevis digitorum has the strongest arch-raising action, owing to its insertion into the second phalanges, placing it at a disadvantage in bending the toes compared with flexor longus. The flexors of the toes should be used to assist progression in walking fast or running, and most people use them for this purpose. They thus support the arch at the moment when the greatest strain falls upon it. Flexor brevis hallucis, pulling from the cuboid to the first phalanx of the great toe, probably assists considerably in supporting the transverse arch.

The transverse arch is maintained chiefly by the dorsal interossei, and this is their most important action. In a demonstration given recently at the Royal Society of Medicine, I think I showed this clearly, using the method I shall describe shortly, and giving a clear picture of these muscles with their bipennate origins, drawing the metatarsal bones together. To describe the action of one of these muscles will suffice to explain the action of the rest. We will consider the second metatarsal bone as the "keystone" and as the middle line. When the second

dorsal interosseous muscle contracts, it performs the following rôles, in the order given. These rôles have been carefully observed during electrical stimulation, first of individual muscles and then of the group as a whole.

1. Feeble contraction. Abduction of first phalanx from middle line.

2. Stronger contraction. Flexion of metatarso-phalangeal joint plus the pull on the extensor tendon. End of toe brought into contact with the ground. (In voluntary movement this contact is of course strengthened by the long and short flexors.)

3. Powerful contraction. The fixed points from which the muscle acts are now (a) the second metatarsal bone, (b) the insertion of the tendon into the first phalanx. As the muscle contracts, the third metatarsal bone is drawn towards the second—that is, towards the middle line. In voluntary movement the second metatarsal is fixed by the opposition of the first dorsal interosseous muscle, which also fixes the first phalanx of the second toe while it is drawing the first metatarsal bone towards the second, and so on. As each metatarsal bone is drawn towards the second, it is pulled into a plane below that of its more mesial neighbour, so that the second metatarsal—the keystone—is raised upwards. This movement is aided by the metatarsals being brought into line with the arch of the cuneiform bones.

The following is the method by which all the muscles I have mentioned may be exercised and brought into a state of efficiency, even when they are wasted and unhealthy from prolonged pressure and disuse. It demonstrates conclusively also the actions I have described above.

The foot is placed in an ordinary porcelain arm bath containing a sufficient depth of warm water to reach just below the external malleolus. The heel rests on a carbon electrode, to which is connected one of the terminals of a Smart-Bristow coil. Another carbon electrode, connected with the other terminal, is held in the left hand. It is dipped into the water in front of the toes. The right hand manipulates the core of the coil so that a surging faradic current is sent streaming through the intrinsic muscles of the foot. Experience will teach the operator how the position of the electrodes may be altered so as to obtain contraction of the different muscle groups at will, and their action is thus displayed in a particularly useful and pleasing manner.

As we proceed to carry out this treatment and place the electrodes in the required positions a clear view is gained of the transverse arch of the foot, rising and falling in time with the contraction and relaxation of the dorsal interossei. It is seen that this is a powerful action and emphasizes the importance of these muscles. The best position for the electrodes varies in different patients, but as a rule in treating the transverse arch I have them on each side of the front of the foot. The longitudinal arch, lateral and medial, is best operated with the heel on one electrode as first described. No stimulation of the long flexors takes place with this technique, and the action of the short flexors of the toes in raising the longitudinal arch will come as a complete surprise to those who see it for the first time, as it is so very marked. The long toe flexors and tibialis posterior can be stimulated in turn by detaching the cord from the electrode at the heel and fixing it to a disc electrode covered with a handful of wet lint so that it can be applied to their motor points. The other electrode occupying a suitable position in the bath. Flexor longus hallucis and flexor longus digitorum when stimulated in this way will be seen to raise the longitudinal arch to a very marked extent.

As to the indications for the application of the above technique as a method of treatment, these are several. It is applicable when the preliminary stages of flat-foot are curable by physiotherapy, and to the after treatment of those more advanced cases which have been wrenched and fixed in plaster or have undergone surgical operation. Regarding the first class, there are many people walking about the streets suffering from what they describe as tender feet, and these people, experiencing pain on movement of the tarsal joints, avoid this as far as possible by planting their feet flatly on the ground with the toes pointing too far outward. This leads them through the successive stages of flat-foot.

Common causes of tender feet are deformity of the first metatarso-phalangeal joint owing to the fashion, common to almost the whole of civilization, of wearing boots shaped like a lead pencil, and, in women, the wearing of high

heels, because this tilts up the metatarsals at the back so that their heads press too much downward at the metatarsophalangeal joints and cause sprains. The splintage of the foot in too tight a boot also causes atrophy of the intrinsic muscles from pressure and disuse, so that they become unhealthy and accumulate fatigue products and probably uric acid. The circulation of the whole foot becomes impaired in these cases, the tarsal joints suffering in common with the rest of the part. Walking in the manner above described entails the relaxation of all the arch-raising muscles, with obvious results.

Faradic treatment given in the manner I have explained yields surprisingly rapid results in such cases. The nutrition of the whole foot is quickly improved, and in most cases metatarsalgia disappears. As a preliminary to voluntary exercise after surgical operation it is highly to be recommended. It is waste of time, and discouraging to the patient, to begin re-education before these muscles are in at least a fair state of nutrition, and I regard it, after seeing the surprisingly good results that it yields, as essential in the satisfactory treatment of flat-foot. It is often impossible or extremely difficult to develop the small muscles by voluntary exercise alone. This applies especially to those cases that have been repositioned by surgical methods, so that the muscles are relaxed after a long period of overstretching with the accompanying atony.

It is very important that the treatment should be given with care and intelligence, because the muscles are completely at the mercy of the operator, and treatment must progress by easy stages from a gentle beginning, otherwise the muscles will be over-fatigued and the condition aggravated. The contractions must be rhythmic, they must not last too long, and they must be divided by periods of complete relaxation. A Smart-Bristow coil is almost essential, as the best results cannot be obtained with the other coils in common use at the present time.

Memoranda:

MEDICAL, SURGICAL, OBSTETRICAL.

LABOUR IN A CASE OF ENCEPHALITIS LETHARGICA.

THE following case came under our care at the Aberdeen Maternity Hospital, and as the condition seems to be very rare, these notes may prove of interest.

Mrs. L., a primipara, was admitted to the Aberdeen Maternity Hospital on February 12th, 1921, with the history that she had been suffering from "sleepy sickness" for ten days. The patient was stated to be nearly at term.

She was very drowsy, but could be roused to answer questions sensibly. She had a dull, vacant, mask-like facies, no wrinkle being present on the brow or face. The eyelids drooped, and could not be raised to the full extent. Movements of the face and tongue were sluggish, but there was no limitation of ocular movements and no nystagmus. Reflexes were normal with the exception of the knee-jerks, which were exaggerated, and the abdominal reflexes, which were absent. The pupils responded sluggishly to light. The patient was very constipated and the mouth was very dirty. The child was presenting by the vertex, and the head was engaging the brim of the pelvis; the foetal heart sounds were heard distinctly in the middle line below the umbilicus, and the rate was normal.

On February 13th the patient became restless and seemed less lethargic; attempts to hear down were noted. Shortly after this the membranes ruptured and the os was found to be fully dilated. Bearing-down efforts were poor during the second stage and seemed to be sluggish, but the patient did not seem to appreciate much pain, though when questioned she stated she felt the pains. The head was delayed at the outlet, owing as it seemed to insufficient expulsive powers; delivery was therefore completed with forceps under a very light anaesthesia of chloroform and ether. The child weighed 9 lb. 9 oz. The placenta came away thirty-five minutes later, and during this time the patient became very lethargic; this condition continued for twenty-four hours, and it was with great difficulty that she could be roused at all. During this time it was noted that the left pupil was smaller than the right, and that there was a left external strabismus; there was incontinence of urine. On being questioned she would stop in the middle of her answer and apparently go to sleep. On February 17th she became less lethargic and took at times some interest in life, displaying interest in the baby when it was shown to her. When questioned regarding it, she had no recollection whatever of the labour. The baby was quite healthy and showed

no signs of drowsiness or oligopnoea at birth or after. On the tenth day of the puerperium the patient was transferred to the City Hospital, her condition being much improved.

It will be seen that in this case pregnancy seemed to be unaffected by the disease, but the lethargy was exaggerated for the first few days after labour, and especially for the first twenty-four hours. The patient slept through the first stage of labour without giving any sign that labour was in progress, and the end of the second stage was delayed on account of defective expulsive efforts. The third stage was normal in every respect and no excess of blood was lost. The puerperium, except for the conditions noted above, was uneventful and the uterus underwent normal involution.

We are indebted to Professor McKerron for permission to publish this case.

W. F. THEODORE HAULTAIN, O.B.E., M.C.,
M.B., B.Ch., Obstetric Physician, Maternity Hospital.
G. O. THORNTON,
House-Surg. on, Maternity Hospital.

Aberdeen.

HERPES AND VARICELLA.

THE following case illustrating the herpes-varicella association may be of interest to record for the following reasons: First, there seems no possible doubt as to the varicella infection having been passed on from the herpes case, as both patients were inmates of the same house, standing by itself right out in the country; moreover, during the possible incubation period of the varicella no visitors came to the house nor had any cases occurred in the neighbouring farms or villages as far as I could ascertain. Secondly, taking the incubation period of varicella as fourteen days it would appear that herpes can remain infectious for at least seven days from its eruption.

On January 27th I was called to see a girl aged 25 who was complaining of pain in the right iliac fossa, simulating appendicitis. On January 28th a few vesicles were noted in this area, and on the following two days a typical herpetic eruption came out over the right buttock, groin, vulva and inner side of thigh; there were no vesicles elsewhere on the body. Three weeks later, on February 18th, the patient's small brother, aged 4 years, developed the typical eruption of varicella; during the whole intervening period he had been in and out of his sister's room daily.

I might add that I was quite unable to elucidate the origin of the herpetic infection; the patient, however, worked in a clothing factory some four miles away from her home.

Desborough.

G. F. P. GIBBONS, O.B.E., M.B.Lond.

IN view of the recent reports of the apparent relationship between herpes and varicella, the following cases appear worthy of note: During the first week in January, 1921, I saw a girl, aged 9 years, who had a typical varicella rash. One week later a younger sister was brought to me complaining of pain in the fifth right intercostal space, and on the following day there appeared a herpetic eruption confined to this region.

Both children soon got well, but during their convalescence a third child in the same house had an attack of varicella. There were no other cases of varicella which I attended at the time, so I was led to suppose that the herpes in the second case acted as a link between the two cases of varicella.

Fochriw, Glam.

T. STENNER EVANS, M.B., B.S.Lond.

TREATMENT OF LOCAL LEISHMANIASIS.

THE note by Colonel Erskine Risk on the treatment of Baghdad boils by scraping (February 19th, p. 267) leads me to say that it is by far the most satisfactory method of treatment hitherto suggested.

During 1917 and 1918, while serving in Mesopotamia, large numbers of Indians suffering from these sores came under my care, and I had ample opportunity to observe the results of treatment. My routine treatment was to scrape the sores thoroughly with a sharp spoon, and then to cauterize the base with pure carbolic. I treated more than two hundred cases in this way, and the average length of time which elapsed before the sores were completely healed was seventeen days. I found that sores on the face healed more quickly than on any other part of the body after scraping.

As far as I could ascertain recurrences were very uncommon, and the scars left were far less obvious than when the sores had been treated by any other method. The secret of success lies in the thoroughness of the scraping, especially at the edges of the sore.

Newmarket. NORMAN GRAY, M.D., B.Ch.Cantab.

Reports of Societies.

CHEMICAL ESTIMATION OF GASTRIC FUNCTION.

At the meeting of the Medical Society of London on February 18th, Sir W. HALE-WHITE presiding, a discussion took place on the chemical estimation of gastric function.

Dr. J. H. RYFFEL, in opening, gave a summary of chemical work on the stomach, and dealt in particular with the two test meals most generally used—namely, that of Ewald (tea and toast) and that of Boas (oatmeal gruel). After showing a large number of gastric-analysis charts, with the curves for acidity and for free hydrochloric acid, Dr. Ryffel summarized the results of his observations by saying that in carcinoma ventriculi the only distinctive type was carcinoma of the pylorus, with no free HCl, high mineral chloride, lactic acid, and blood with the "coffee grounds" appearance. Cases of carcinoma in which there was no gross obstruction were far less distinctive. Lactic acid was usually absent, free HCl was absent, and the physiologically active HCl was low, but this held good of many other conditions as well. Mineral chloride was nearly always high, but it was occasionally high in other conditions with low HCl, such as pernicious anaemia. Occasionally in these cases the free and the active HCl were normal; the mineral chloride was high, but high mineral chloride might be found in ulcer of the body of the stomach, especially with regurgitation. The presence of blood would not distinguish from ulcer. Blood might be due to trauma during aspiration of the meal, and in this connexion he had found it necessary to insist on examination of the faeces for blood in every case. If blood in the gastric contents was due to slight trauma during aspiration, no blood would be found in the faeces; blood also might be found in the faeces when it was not appreciable in the gastric contents. Spectroscopic examination of the faecal extract for acid haematin and haematoporphyrin, in addition to the ordinary tests for blood, was very useful. In simple ulcer, especially ulcer of the body of the stomach, the HCl was not by any means always above normal, and here again the bleeding was capricious; blood might be absent from the stomach but present in the faeces, or absent from both. Whether the older form of test meal or the fractional meal were employed, cases needed to be further tested by the examination of the faeces for blood, and, of course, all such tests could only be usefully employed in conjunction with the clinical study of the case.

Dr. J. A. RYLE was specially interested in the diagnostic possibilities of the fractional method of gastric analysis, and thought it of first importance to keep the method as simple as possible. The fractional test meal might at a sitting definitely establish a diagnosis of pyloric stenosis. In active pyloric or duodenal ulceration a very striking curve was obtained. In all fractional tests it was of special importance that the resting juice of the stomach should be carefully examined.

Mr. E. C. DONNS said that valuable information might be obtained with regard to gastric secretion by taking the percentage or tension of the carbon dioxide in the alveolar air. He gave examples of the typical diphasic curve of tension of CO₂ obtained in taking the meal, and said that he believed the rise which was shown was gastric in origin, due to secretion of hydrochloric acid, and that the fall was due to gastro-intestinal secretion, probably pancreatic.

Dr. T. I. BENNETT urged that if any valuable estimate of gastric function was to be made, it must be made by some method which tested samples taken at every phase in the gastric scale. Any gastric test which was taken at a fixed point after the ingestion of a meal must be liable to grave fallacy, and in proof he showed curves illustrating the variation of gastric function at different times in normal persons.

Dr. R. L. MACKENZIE WALLIS also gave particulars of gastric tests and advocated the Ewald test meal, because it enabled a complete analysis to be made, not only of the total acidity and the free HCl, but of the mineral chlorides as well, and these mineral chlorides furnished a definite indication of regurgitation or neutralization such as was met with in carcinoma of the stomach.

Dr. G. GRAHAM wanted a more complete chemical analysis than was usual with the fractional test meal alone. One could not do a complete chemical analysis every quarter of an hour, but it should be possible to do a complete analysis at the end of the hour. If the test meal was going to be done it should not be started until it was certain that the patient was no longer constipated.

Dr. W. H. WILCOX also urged the need for chemical accuracy with the test meal. In the fractional test meal one worked with such small quantities that there was considerable danger of error in the acidity and hydrochloric acid determinations thereby made. He thought that the fractional test meal had not completely supplanted the older method of the hour test, which remained a very valuable means for eliciting the condition of the stomach.

Dr. RYFFEL, in reply, agreed with Dr. Wilcox that the old form of test meal was by no means outdone. Certainly it would be an improvement, if it were practicable, to combine the fractional method with the other. In answer to a question as to the usefulness of determining ferment activity, Dr. Ryffel said that he had done practically nothing in this line himself, being somewhat hesitant about accepting the idea that rennin determination would practically reflect pepsin.

HABITUAL DISLOCATIONS.

At the meeting of the Subsection of Orthopaedics of the Royal Society of Medicine on March 1st the subject of recurrent or habitual dislocations was introduced, and several cases were shown by Mr. O. L. ADDISON, Mr. H. A. T. FAIRBANK, and by others who took part in the subsequent discussion.

Mr. LAMING EVANS (the President) defined such dislocation as the condition of a joint which, after dislocation had occurred and had been reduced and had remained reduced, offered a subnormal resistance to redislocation, and in fact suffered repeated dislocations by slight force. The terms "recurrent dislocation" and "habitual dislocation" were accepted as synonymous, though the term "habitual dislocation" was the more accurate. Of these dislocations, that of the shoulder-joint was by far the most common, partly owing to the fact that 50 per cent. of all dislocations occurred at the shoulder, partly because of the methods of reduction in unskilled hands, partly because of defective after-treatment, and partly because of the pathological lesions inflicted by the original injury. Habitual dislocations might be due to osseous, capsular, ligamentous, tendinous, or muscular causes. The pathological lesions which might be present were most various, and this meant that on occasion different methods of treatment must be adopted. He divided the methods of treatment into five: (1) Palliative, by appliances of various material and design; (2) physiological, in the direction of increasing the tone of muscle, tendon, and ligament; (3) reefing operations upon the capsule, either by plication or by excision and overlapping; (4) repair of ruptured tendons and musculo-tendinous insertions; (5) muscle transplantation. A fair trial of mechanical support and physiological toning should be given in all cases before operative measures were adopted. Reefing operations had undoubtedly been followed by many successes and not a few failures. Muscle transplantation had been performed by detaching the posterior fibres of the deltoid passing them round the neck of the humerus, and fixing them in front, so that they offered support to that part of the capsule which was weakened both in subglenoid and subcoracoid dislocations. Opinions differed with regard to the fate of the transplanted muscle. Some held that it retained its contractile power, others that it underwent fibrous degeneration and acted as an additional extracapsular ligament. He gave an account of a case of his own in which Clairmont's operation was performed six months previously, so far with a satisfactory result, although the shoulder had been dislocated very easily, even by the act of sneezing.

Mr. T. H. OPENSHAW said that about fifteen years ago a patient was brought to him whose right shoulder had been dislocated fifty times. He tried various expedients, but got no satisfactory results until he divided the subscapularis, and since doing so there had been no further dislocation. He was convinced that the cause of the dislocation in this instance was over-action of the subscapularis. He had done the same operation since in about ten cases with perfect results.

Mr. A. H. TODD believed, as a result of electrical testing, that the piece of deltoid transferred retained its function; it least in some cases the transplant was not a dead mass. He instanced one case of his own in which Clairmont's operation had been done successfully: a woman who had had an innumerable series of shoulder dislocations, some of them induced by the act of sneezing, but comparatively painless, and capable of reduction without anaesthetic. No further dislocation had occurred during the four months since operation.

Mr. W. ROWLEY BRISTOW said that the use of the abduction splint had been urged in some quarters, but this was a very uncomfortable apparatus, and although there were occasions when it was absolutely necessary, it should be restricted, he thought, to such cases. As for the question of function of the transplanted portion of the deltoid muscle, the fact that in a particular case the transplanted portion responded to electrical stimulation was not proof. Such response would, he thought, occur in every case if a muscle were taken and a part of it divided. There was no time for the degeneration which would cut out the faradic response, and he would expect it to react to the faradic current for a period. Mr. Bristow went on to speak more particularly about recurrent dislocations of the patella. In the simplest of these cases a knee press or redevelopment of the internal vastus should be tried, and might suffice. There must be borderline cases, and one could imagine that the additional pull of a strong internal vastus might correct the tendency to outward displacement. A moderate ridge on the femoral condyle and a good vastus might suffice when a moderate ridge and a poor vastus would fail to prevent the patella riding out too far. The operative procedures were (1) the correction of knock-knee if present; (2) plecting of the capsule on the inner side, which he thought bound to fail; (3) shortening the quadriceps; (4) alteration of the line of pull of the quadriceps by transplanting half or the whole of the patella tendon to the inner side. He had adopted, in addition to the transplantation, a small bone graft after levering up the external ridge on the femur. He suggested that transplantation of the tubercle with a tendon attached was a better procedure than the transplantation of the tendon alone. He further suggested that the bringing forward of the external ridge in the outer condyle was a rational surgical procedure, and only added a few minutes to the time of operation, even when a small bone graft was driven into the femur.

TREATMENT OF STAMMERING.

At a meeting of the Edinburgh Medico-Chirurgical Society on March 2nd, Emeritus Professor F. M. CAIRD presiding, Dr. HAMILTON G. LANGWILL called attention to the valuable work on this subject by the late Professor John Wyllie, and to his classical book *The Disorders of Speech*. His own remarks were largely an exposition of the principles of Wyllie's treatment. But he suggested that the recent treatment of stammering as a war neurosis by psycho-therapeutic methods opened up a new line of treatment which might be useful. The condition was commonest in late childhood and early adolescence, and rarely developed after the age of 20; it was much commoner in boys than in girls, and imitation was sometimes a factor in causation. Wyllie described two main types—one a silent sticking at the utterance of particular sounds; and the other, and more frequent, where there was an audible check with the rapidly recurring utterance of a sound or letter. To the latter type the name "stuttering" was often given. Stammering nearly always disappeared in singing. There were three elements in speech—expiration, vocalization, and articulation—and the essence of stammering lay in an inco-ordination between the two latter, the fault generally lying in too much attention to articulation and in defective vocalization. It was all important that the patient should

understand this double nature of his impediment, and, to make this clear, Wyllie used the simile of a violin where great stress was laid on the string hand, while the bow hand was neglected. Another great aid in treatment was the adoption of intoning, or the adoption of a different accent or tone of speech. Instruction must then be given in the physiological alphabet. The individual letters were to be separately practised, the general rule followed throughout of stressing the vocal element and touching lightly the articulating element. The vowel sounds gave little difficulty, but y and w, which were stepping stones between vowels and consonants, might give trouble. Thus "will you" should be practised as *ōō-ill, ēē-ou*. In the consonants, the voiceless ones, such as p, f, were more difficult for stammerers than the voiced, such as b, v, etc.; and the broad principle governing the practice of all letters was to touch as lightly as possible the voiceless initials and to emphasize strongly the vocal elements in letters. Examples of sentences for practice were given, these being constructed to contain the letters that were stammered, and being diligently practised with the teacher. The patient should stand up during practice, and should use a musical tone of voice. Patience, perseverance, and determination were essential for success.

Dr. A. GOODALL said he had found the simile of a bicycle where there was disproportion between pedalling and guiding more easily understood than that of the violin. The distinction between stammering and stuttering was not important. Dr. MEIKLE spoke of the disappointing results obtained by special classes in schools, possibly due to faulty methods of teaching, but largely owing to lack of interest by the pupils. Dr. TRAQUAIR drew attention to a hereditary element sometimes strongly present. There was a natural tendency to cure, greatly assisted by the determination of the patient to cure himself, and also perhaps by the stimulus of ridicule. Professor G. M. ROBERTSON believed that psycho-analysis might reveal some anxiety or fear at the root of many cases, and that the discovery and removal of this would then be the best treatment. This aspect of the question was also dwelt on by Dr. MURRAY LYON and Dr. BRECK.

Cervical Ribs and Pressure Symptoms.

Dr. EDWIN BRAMWELL and Dr. H. P. DYKES read a paper on the pressure symptoms sometimes associated with cervical ribs, rudimentary first dorsal ribs, and associated anomalies of the brachial plexus. The subject had become of interest to clinicians in the past twenty-five years, though Sir David Wallace had shown a case to the Society in 1890. There were four groups of cases: visible cervical rib without pressure symptoms; visible cervical rib with pressure symptoms; pressure symptoms, and cervical rib demonstrated by x-ray; and pressure symptoms, with a negative x-ray examination, where, however, there might be a rudimentary first dorsal rib or some anomaly of the brachial plexus. The symptoms comprised supra-clavicular prominence and pulsation, scoliosis, evidence of pressure on the brachial plexus and subclavian artery in unilateral muscular wasting of the thenar eminence and abductor pollicis, pain, and occasional sensory disturbance and diminution of radial pulse. Oedema of arm and hand from venous pressure was very rare. Wood Jones believed the condition to be due to a fault or antagonism between the nervous elements and mesoblastic segments of the upper limb bud, and certainly pressure symptoms occurred without cervical rib. An x-ray finding of cervical rib, therefore, only corroborated the clinical evidence, and the diagnosis could not be based on the x-ray examination alone. The differential diagnosis from peripheral neuritis, progressive muscular atrophy, and syringomyelia was discussed. The condition was much commoner in women. As to treatment, many slight cases required no operative treatment; and rest of the arm and shoulder by sling, and counter-irritation over the brachial plexus were of value. Operation in selected and severe cases was very successful in the relief of pain and occasionally in improvement of muscular weakness.

Sir HAROLD STILES described the operation. He advised an L incision, the vertical limb along the anterior border of the trapezius, and the horizontal coming inwards along the clavicle; it should be free. Dissection of the parts then proceeded inwards. The greatest danger was injury of the roots of the nerve of Bell which pierce the scalenus

medius close to its insertion. These should be looked for, and the muscle then divided close to its rib insertion. Injury of the pleura was more easily avoided, and if it took place was not serious. He added to the symptomatology the occurrence of chilblains and of pain in the neck from pressure of braces and coats. He suggested that weakness of the trapezius was sometimes a factor in causing the condition.

THE INFLUENCE OF DIET ON THE TEETH.

At a meeting of the London Association of the Medical Women's Federation on February 15th, when Mrs. FLEMING, M.D., was in the chair, Dr. HANDLEY-READ read a paper on "The influence of diet on teeth during the pre-natal period, dental caries, and pyorrhoea alveolaris." She emphasized the importance of accessory food factors as essential to growth, and pointed out how it has been proved that the antirachitic fat-soluble A vitamine was a necessity in diet if the hardest tissue of the body and that requiring the best nourishment—namely, the enamel of the teeth—was to develop properly. The temporary teeth were fully formed in the jaws before birth, though calcification began in the sixteenth week and continued throughout their existence; hence it was evident that the mother's mode of living during pregnancy and lactation must influence the teeth of the child, and her diet must include liberal supplies of fat-soluble A and water-soluble B vitamins. Even at the worst war period the diet of the poorest working woman of this country had just sufficient essential vitamins to produce bone and tooth tissue fairly well calcified, and observations at baby clinics, etc., showed that the teeth of all babies erupted fully formed with apparently good enamel; but if the diet was poor in essential vitamine (antirachitic) the enamel was found carious within a few months.

The infant's diet after weaning, the transition from liquid to solid food, should not be via pap food, as this was bolted without proper mastication and insalivation. By 1½ years of age, with normal dentition a child should be able to masticate an apple, while from 2 to 5 years a child should be capable of masticating any hard food. The County Council classes in their syllabus advised a diet which was almost entirely of pap food, and yet insisted on the importance of mastication!

Pyorrhoea alveolaris was now rampant all over the world among white and coloured races, and was also common in animals kept in captivity. It seemed probable that excessive carbohydrate and deficient antiscorbutic diet largely accounted for this. In true scurvy acute periodontitis was a marked symptom, and the teeth dropped out if antiscorbutic treatment was delayed. Probably modern diet contained sufficient antiscorbutic to prevent actual acute scurvy, but not to prevent chronic periodontitis. We had pyorrhoea because in the mouth we had damaged tissue in the form of inflamed gums, due to pap food; bacteria were always present, and we had a diet deficient in antiscorbutic vitamine. That many vegetarians suffered from pyorrhoea was probably explained by the fact that they were mostly very large consumers of carbohydrates and that their vegetables or fruit were rarely eaten raw. In Asiatic races caries was rare, but the teeth dropped out at middle age in those parts of the country where the antiscorbutic factor was deficient in the diet. Dr. Handley-Read then described several cases in which she found acute pyorrhoea which had completely cleared up on a diet of raw vegetables, salads, fruit, eggs, and a little milk, with very limited carbohydrate. Such an intensive vitamine diet produced astonishingly good results. While firmly believing in the efficacy of such treatment for chronic periodontitis, local treatment by drugs, vaccines, and irrigation was not to be neglected.

A discussion followed the paper, in which Dr. LEWIS, Dr. HARE, Dr. HARDING, and Mrs. FLEMING took part.

At a meeting of the North of England Obstetrical and Gynaecological Society, held at Liverpool on February 18th, with the President, Mr. CARLTON OLDFIELD, in the chair, Drs. GEMMELL and LEYLAND ROBINSON (Liverpool) showed three specimens of uterine fibroids where other complications were present. In two of the specimens the fibroids coexisted with carcinoma of the body of the uterus. In the third specimen a left hincinosalpinx was present,

and was evidently produced by torsion, as evidence of ectopic pregnancy. Drs. WILLETT and HENDRY (Liverpool) showed a specimen of hydatidiform mole, with a well developed four and a half months foetus and placenta. They were of opinion that this was a case of twin pregnancy in which one ovum had undergone vesicular degeneration. Dr. W. W. KING (Sheffield) described a case in which acute symptoms arose during pregnancy from the rupture of a vein on the surface of a subperitoneal myoma of the uterus. At the operation a large quantity of free blood was found in the peritoneal cavity. The tumour was removed by myomectomy and the pregnancy left undisturbed. A discussion took place on Dr. Lacey's paper on induction of labour for moderate contraction of the pelvis, read at the last meeting of the society (BRITISH MEDICAL JOURNAL, February 5th, 1921, p. 195). The opinion of the majority of the speakers was that although excellent results could no doubt be obtained in hospital, as Dr. Lacey's figures showed, the method was extremely tedious in private practice, and apt to cause a good deal of anxiety to the patient and her attendant. Caesarean section should be the operation of choice where there was any reason to fear that delivery of a healthy full-term child by the natural passages was going to be impossible.

Reviews.

SURGICAL SHOCK.

PROFESSOR G. W. CRILE has rewritten his book on *Anoci-Association*, first published in 1914, but this time it appears under the less intriguing title of *Surgical Shock*.¹ As on the previous occasion, Professor Crile's name is bracketed on the title-page with that of his old and valued friend and assistant, Dr. W. E. Lower. This book, like all Crile's writings, is most stimulating, most provocative, and most speculative. It commences with a frank and interesting summary of the evolution in the Cleveland laboratories of the author's kinetic theory of shock. The many ingenious theories and experiments are here briefly reviewed, but, wide though their scope has been, they have led to negative more often than positive results. Crile has a wide vision, an all-embracing mind, but the issues which he raises, the problems which he has set himself to solve, are too vast for answer by one man. The marvel is that his imagination has been so fertile in suggesting new theories each time that he has had regretfully to abandon the old. In spite of the supreme difficulties of his task, Crile has succeeded beyond anyone else in suggesting methods of combating an entity which neither he nor others are able convincingly to explain. He is above all a man with a passionate belief in his cause. His intense enthusiasm has won him a host of converts and disciples. Yet those who hold themselves aloof from his influence will have little difficulty in finding faults in his work. His photographs, for instance, of exhausted tissue cells are either accepted as part of the faith or are gazed at with sceptical and agnostic eyes. "Where," the unbeliever asks, "are the detailed records of these countless experiments? How often has this particular experiment been performed? Is not such and such a histological appearance within the limits of the normal?" We are informed that upwards of 3,000 animals and men have been histologically examined. A life-work indeed!

Crile's detailed work is vulnerable, but his general kinetic theory of shock is extraordinarily ingenious and seductive. It has enabled him to elaborate and to perfect methods of preventing shock which will probably ensure the handing on of his name to posterity. With the knowledge that general inhalation anaesthesia does not prevent an animal from receiving subconscious painful impressions, and the knowledge that stimuli of sufficient number or intensity cause exhaustion and may cause death, Crile set himself to find a technique which would reduce the nervous impulses to a minimum. This technique he now calls "Anociation," a handier word than the former "Anoci-association." Crile's *er 7* is embodied in this passage:

"The one great exciting cause of surgical operation shock is the surmount every contact of his instrument with an unanaesthetized nerve-ending, nerve filament, or nerve fibre;

¹ *Surgical Shock and the Shockless Operation through Anoci-Association*. By G. W. Crile, M.D., and W. E. Lower, M.D. Second edition of *Anoci-Association*, thoroughly revised and rewritten. Edited by Amy F. Rowland, B.S. Philadelphia and London: W. B. Saunders Co. 1920. (Roy. 8vo, pp. 272; 75 figures. 28s. net.)

every drop of blood which he sheds; every moment he requires the continuation of inhalation anaesthesia; every moment he exposes sensitive tissue to the air; every interference with adequate ventilation of the lung; every thrill of fear he introduces into his patient—each of these is an exciting cause of shock, and the combined result of all may be death.¹

The "anociative" technique requires no special apparatus; it is within the power of all surgeons to apply. We venture to assert that few who do employ Crile's methods will fail to gain greatly for their patients and themselves. Something of value has been added to surgery, and we are Professor Crile's (and Dr. Lower's) debtors.

There are no radical changes in this second edition, but there is a general improvement in the chapters describing individual operations. We note that urea hydrochloride is now used very cautiously and only on special occasions.

Dr. Geoffrey Marshall, some of whose charts are reproduced, is incorrectly referred to as Dr. Gregory Marshall.

ANTISEPTIC AND ASEPTIC.

DR. CHARLES SINGER of Oxford, lecturer in the history of medicine at University College, London, is editing a set of volumes which, under the general title "Medical Classics Series," is to be published by Messrs. John Bale, Sons, and Danielsson. The object of the series is to reproduce some of the most epoch-making contributions to medical science. Each volume will be complete in itself, and each will contain a brief note on the author's life. The first volume² consists of *Six Papers by Lord Lister*, selected by Sir RICKMAN GODLEE, who has written a short biography and added a few explanatory notes to the papers. The biography, as was to be expected, is very well done; in the course of it Sir Rickman Godlee takes occasion to discuss what he rightly calls the thorny subject of aseptic surgery, as opposed to antiseptic surgery. He points out that aseptic surgery, as it is now understood, was almost from the first Lister's ideal; he tried to adopt it as early as 1868 and on other later occasions, but he did not persist in the attempt because he thought that antiseptic surgery was equally efficient and more easily carried out. It is pointed out that the principle underlying the two methods is identical, the object of both being to prevent the access to a wound of pathogenic micro-organisms in such a condition or in such numbers that they have a chance of living and of propagating themselves. In the earliest days Lister thought he had succeeded in keeping germs out of wounds altogether, but afterwards it was shown that complete exclusion was rarely attained, was sometimes impossible, and not really essential. In rendering their applications free from germs aseptic surgeons trust more to heat and less to chemical substances than Lister did, but since the importance of the skin as the source of wound infection has been realized, antiseptics have been used both for the skin at the site of operation and for the surgeon's hands.

The volume contains six essays; the first the paper on the early stages of inflammation, communicated by Lister to the Royal Society in 1857; the last the address on the present position of antiseptic surgery which he delivered before the International Medical Congress in Berlin in 1890. Among other essays is Lister's report of the demonstrations of antiseptic surgery he gave before the British Medical Association at its annual meeting in Edinburgh in 1875. The volume is illustrated by a reproduction of a well known photograph of Lister when about 60, and of an early photograph of Lister and his wife; there is also a facsimile reproduction of a letter by Lister written in 1861 to his father.

THE SPHYGMOMETER IN PRACTICAL MEDICINE.

PROFESSOR W. RUSSELL of Edinburgh, who has written much on arterial disease in his monograph *Arterial Sclerosis, Hypertonus, and Blood Pressure*, at present out of print, as well as in numerous papers, now publishes, under the title *The Sphygmometer: Its Value in Practical Medicine*,³ his George Alexander Gibson Memorial Lectures

for 1920, appropriately dealing with a subject in which his late colleague took so much interest, and also eight papers that appeared between the years 1908 and 1917. These pages contain a clear exposition of very definite opinions based on many years of clinical observation. The view that the sphygmometer gives the true brachial blood pressure, and that 5 mm. Hg only need be allowed for the vessel wall, whatever its condition, is strongly opposed by the author, who has always contended that thickening of the arterial wall from sclerosis, from hypertonus, or from hypertonus in a sclerosed artery, is the important factor in sphygmometer readings. The sphygmometer is of great value in demonstrating the relaxation and contraction, or the play of tonus, in thickened arteries, and sphygmometer readings should not be regarded as providing an assured record in terms of "blood pressure." Another point that is firmly emphasized is that sclerosed arteries are not necessarily or even usually atheromatous, and that the sclerosed artery seldom, if ever, becomes a rigid tube. Arterio-sclerosis is defined as a uniform thickening of the middle coat of the arteries in their whole length, whereas atheroma occurs in patches and, like calcareous infiltration, is comparatively rare in the radial artery even of old people. Hypertonus is described as occurring both as a prolonged and as an oft-recurring increase of the normal degree of contraction of the arterial muscular coat which is physiologically called tonus; further, hypertonus, though raising the sphygmometric reading, implies a diminished quantity of blood in the vessel and a fall of the blood pressure inside it. Cases showing the association of hypertonus with migraine, cardiac distress, anginoid symptoms, excess in tobacco, and epileptoid attacks are given. Disordered gastric function may cause hypertonus, which is removed by purgation, and the importance of gastro-intestinal disturbance in the production of arterio-sclerosis is emphasized. Dr. James MacDougall is quoted to the effect that enlargement of the prostate occurs only or mainly in persons with well-marked arterio-sclerosis, and it would be interesting to have heard some discussion on the question whether there is any real relation between these two changes so common in advanced life, or whether the association is analogous to that of baldness and arterio-sclerosis.

PHARMACOGNOSY.

THE second edition of Dr. KRAEMER'S *Scientific and Applied Pharmacognosy*⁴ follows the first after an interval of five years. The greater part of the book is devoted to descriptions of crude vegetable drugs arranged according to the natural relations of the plants from which they are derived, but a few of the more important animal products are also considered. The sources, constituents, and commoner impurities of each drug are fully treated and the literature is adequately cited. One of the more prominent features of the work, and especially of this edition, is the author's wide view of the scope of his subject. The implied definition of pharmacognosy as the study of raw materials and the products manufactured from them will be considered too inclusive by many, but the strongly expressed opinion that pharmacognosists must have at their command, and be able to apply practically, a number of widely different branches of science must be accepted. Not only is a sound general knowledge of such subjects as chemistry and botany needed; highly specialized departments of these also find application. Among the problems requiring the applications of plant physiology are the relations of soil and climatic conditions to the variations in the constituents of drugs, and we should be on firmer ground here if we knew more of the part played by alkaloids, glucosides, and the like in the economy of plants. In approaching the subject of the cultivation of medicinal plants we are confronted with the problems of hybridization and mutation. Systematic experiments in drug cultivation have received increased attention of late, especially in America, and the results so far obtained seem to show that soil and weather have relatively less influence upon the yield

² *Six Papers by Lord Lister. With a Short Biography and Explanatory Notes by Sir Rickman J. Godlee, Bt., K.C.V.O., M.S. Medical Classics Series. 1921. London: John Bale, Sons, and Danielsson, Ltd. (Crown 8vo, pp. vii+194. 10s. net.)*

³ *The Sphygmometer: Its Value in Practical Medicine. By William Russell, M.D., LL.D. London: Baillière, Tindall, and Cox. 1921. (Demy 8vo, pp. 157; 14 figures. 7s. 6d. net.)*

⁴ *Scientific and Applied Pharmacognosy. Intended for the Use of Students in Pharmacy, as a Handbook for Pharmacists, and as a Reference Book for Food and Drug Analysts and Pharmacologists. By Henry Kraemer, Ph.D., etc. Second edition. New York: John Wiley and Sons, Inc. London: Chapman and Hall, Limited, 1920. (Med. 8vo, pp. 748; over 300 plates, comprising about 1,000 figures. 35s. net.)*

of active principle than has the individuality of the plant; hence the best results have been obtained by seeking out the better individuals and propagating from these. By this method it has been found possible to increase considerably the yield of alkaloid given by such plants as belladonna. As a nation we cannot claim to have been particularly progressive in these matters, but the effort now being made to increase the area of cinchona plantation in India, with the object of rendering that country capable of supplying the whole of the British Empire with quinine, is a step in the right direction. We note that attempts are being made in America to standardize certain drugs by observing their toxic action on germinating seedlings.

Dr. Kraemer emphasizes the application of chemistry to micro-analysis and to the elucidation of the little understood fermentative and other changes which take place in the drying and maturing of drugs. Many new and important applications of physical and crystallographic methods are also cited. To the scientific equipment of the pharmacognosist as recommended by the author we would add a knowledge of zoology and animal physiology, in view of the increasing number of animal substances now being employed in medicine. The outcome may be that in pharmacognosy, as in many other subjects, the bulk of the advances of the future will result from the team work of specialists rather than the efforts of individual investigators. The volume before us is furnished with excellent and abundant illustrations, those dealing with microscopic structure being particularly good. The book is one of the best of its kind.

HUMAN ANATOMY.

New manuals of human anatomy are not uncommon, but Professor PITZMAN'S *Fundamentals of Human Anatomy*⁶ deals with the subject in a manner which is, in many ways, original and deserves serious consideration at the present time, when the reconstruction of the medical curriculum is giving rise to much discussion. It is possible that, in the near future, less time will be devoted to the study of human anatomy in the pre-clinical period, although this may be balanced by more extended courses of applied anatomy, running throughout the clinical period of study. Should such a change come about, it would be found that most of the existing textbooks contain much more detail than it would be advisable for the student to attempt to absorb in the time at his disposal, and that a manual on similar lines to Professor Pitzman's would be essential.

The author rightly emphasizes the very intimate relations which exist between anatomy, physiology, pathology, and the clinical subjects, and expresses the belief that anatomy can be taught most efficiently by constant references to its applications. It may be admitted that the author's aims are in every way praiseworthy and deserving of support, but approval cannot so readily be accorded to the manner in which these aims have been carried out. It ought to be possible in a book of this size to include all facts of human anatomy which are likely to prove of value to the average practitioner in his daily work, but much of this information has been excluded. Particularly is this true of the central and peripheral nervous systems. It is unfortunate that this defect is not compensated for by the soundness of the teaching in other respects. The movements of the knee-joint and the functions of its crucial ligaments are not described in accordance with English views, and such statements as "the clavicle is bound down firmly . . . by the coraco-clavicular ligament" convey a quite erroneous impression of the function of that ligament.

When we come to the choice of particular examples to illustrate the applications of anatomy to medicine and surgery, there must always be a difference of opinion as to relative values, and it would be unfair to cavil at the examples selected. Such instructions for dissectors as are included are very brief, and a student dissecting his first "part" would not find them very helpful. It would have been wiser to have omitted the instructions altogether than to have included them as they stand.

Despite such criticisms as have been offered, the fact remains that the book is an endeavour to show that

human anatomy, as taught in the pre-clinical period of medical study, can be made simpler, more generalized, and more helpful. At the same time, it must be remembered that such a method of teaching the subject can only prove satisfactory when it is supplemented by a series of courses on applied anatomy during the clinical period.

NOTES ON BOOKS.

THE late Sir CHARLES A. CAMERON, of whom an obituary notice appears this week at p. 405, was born as long ago as 1830. In his *Autobiography*,⁶ which appeared a short while ago, there are many interesting stories and reminiscences told in a genial and breezy style. His earliest recollection was that of a very old woman who, eighty-eight years before, had seen part of the battle of Culloden (1746). Though born in Dublin, he belonged to the Lochiel branch of the Clan Cameron, and there are several anecdotes of the amusing confusion that occasionally arose between him and his *alter ego*, as he called him, Dr. (now Sir) Charles Cameron, M.P. for the College Division of Glasgow. The author, after sixty-five years of dinner parties, formed the conclusion that such pleasant reunions were conducive to longevity. In 1852, when 22 years old, he became a professor of chemistry, ten years later he was elected public analyst, and in 1874 medical officer of health to the City of Dublin, a post that he held until his death. He had also been professor of chemistry to two other bodies in Dublin as well as for a time professor of anatomy to the Royal Hibernian Academy, of which he was an honorary member. The appreciation in which he was held is incidentally shown by the number of presentations made to him.

The first part of the *Kystoskopischer Atlas*,⁷ produced by Dr. med. ERICH WOSSIDLO, is devoted to a description of various forms of cystoscope; the author apparently favours the Nitze instrument, and for catheterization of the ureters the special instrument of Rieglieb; other forms are not discussed. Following this is a brief description of the technique of cystoscopy; the remainder of the text deals with the various abnormal conditions which may be found in the bladder, with brief notes on their pathological anatomy, their etiology, diagnosis, and methods of treatment. The chief value of the work lies in a series of coloured plates (thirty-eight in all), each plate containing some four or five cystoscopic views. These illustrations are, on the whole, of a high order and cover a very large range of subjects.

It is not surprising that a second edition of Dr. C. PRICE-JONES'S handy and clearly written introduction to clinical haematology entitled *Blood Pictures*,⁸ first published in 1917, has been called for. In a small space it gives the maximum amount of information for the interpretation of blood counts, and is accompanied by five admirable coloured plates, which should, together with the technical directions in the text, provide an invaluable guide to house-physicians and clinical clerks. The leucocytes are divided into the leucoid or granular, the lymphoid or non-granular, and abnormal cells, degenerated and immature, and there is a phylogenetic diagram of the blood cells facing a coloured plate of the marrow cells for comparison. Dr. Price Jones points out that, broadly speaking, a leucoid type of blood is associated with a coeptic infection, a lymphoid type of blood with a bacillary infection, and a lymphoid *plus* a large mononuclear type with a protozoal infection. Twenty blood counts are given, and their diagnostic significance are discussed in the light of an extensive experience. Arneith's count is not referred to by name, but the author remarks that a classification of the polymorphonuclear leucocytes based on the number of their nuclear divisions has little practical bearing. An appendix contains a summary of the author's recent work on the diurnal variations in the size of the red cells.

⁶ *Autobiography of Sir Charles A. Cameron*. With an Introduction by the Right Hon. Sir James H. M. Campbell, B.A., P.C., Lord High Chancellor of Ireland. Dublin: Hodges, Figgis and Co. (Ed. Ltd.), Mullin and Son, London; Simpkin, Marshall, Hamilton, Kent and Co., 1920. (Demy 8vo, pp. 177, 15 illustrations, 7, 6d.)

⁷ *Kystoskopischer Atlas*. Ein Lehrbuch für Studierende und Ärzte. Von Dr. med. E. Wossidlo. Leipzig: W. Engelmann, 1921. (Demy 8vo, pp. 80; 33 plates; 23 figures. M. 56.)

⁸ *Blood Pictures: An Introduction to Clinical Haematology*. By Cecil Price Jones, M.B. Lond. Second edition. London: John Wright and Sons, 1920. (Demy 8vo, pp. 67, 5 plates; 3 figures. 6s. ed. net.)

THE widow of Professor Cozzolino has recently presented to the oto-rhino-laryngological clinic of Naples the rich collection of anatomical and pathological specimens collected by her late husband.

⁵ *The Fundamentals of Human Anatomy*. By M. Pitzman, A.B., M.D. London: Henry Kimpton, 1920. (Med. 8vo, pp. 356; 101 figures, 24s. net.)

THE FUTURE OF RESEARCH IN TROPICAL MEDICINE.

SIR LEONARD ROGERS, C.I.E., M.D., F.R.S., delivered his presidential address before the Section of Tropical Diseases and Parasitology of the Royal Society of Medicine on February 24th. After referring to the organization of the new Section, and the choice of its title to prevent confusion with the earlier established Society of Tropical Medicine and Hygiene, and to the opportune bequest to the Royal Society of Medicine of the very valuable Chalmers library of tropical medicine, Sir Leonard Rogers said:

I wish to take advantage of the present opportunity to say a few words on the future of research in tropical medicine mainly from the point of view of what this country, and especially this, the wealthiest city of the world—much of whose prosperity is derived so largely from trade with tropical and sub-tropical countries—can and should do for the advancement of what may safely be called the most rapidly progressing and life-saving branch of medical science. We all know the great part the Schools of Tropical Medicine of London and Liverpool have played, both in training so many post-graduates and fitting them to undertake researches in various tropical countries with most beneficial results, as illustrated, for example, by the work of Castellani in Ceylon; and also in sending numerous research workers abroad for limited periods to tackle various problems, such as the pioneer work of Dutton and Todd from Liverpool in the dark continent of Africa; Manson-Bahr's all too short expeditions to study dysenteries in Fiji and sprue in Ceylon, and Leiper's brilliant solution of the life-history of bilharzial parasites in Egypt, both from the London School of Tropical Medicine, to mention only a very few.

While fully admitting the value of the work done by such brief expeditions of research workers to tropical countries, my own work not unnaturally leads me to consider whether the time has not come to modify to some extent the policy hitherto pursued by our English tropical schools, which is also that of the Tropical Diseases Committee of the Royal Society, so fully justified in the past by the brilliant researches of Sir David Bruce and his fellow workers at the very serious problem of the spread of sleeping sickness in Africa with the opening up of trade routes. Any value my own researches may have is solely due to my good fortune in being able to carry out long-continued and patient investigations in a tropical country in a laboratory in the closest possible association with a wealth of clinical material at the Calcutta Medical College Hospital with its 600 beds, for the last twenty years, with three intervals of a few months' leave home. I was thus led to the conclusion that Calcutta presents the finest opportunities for a great school and research laboratories of tropical medicine in the world, and I have devoted much time during the last ten years to organizing such an institution, which has already commenced research work, and will by next October be fully staffed for teaching as well. To this institution a hygiene section, for which the laboratory accommodation is already provided, will be added as soon as final sanction is obtained, when the services of ten Government professors will be available with about three-fourths of their time for research. Further, the response to an appeal I issued several years ago for funds to build a special hospital for 116 beds for tropical diseases and to support additional research workers has been so liberal that at the present time, at the official rate of exchange (which unfortunately is at present considerably over the market rate), over £100,000 has been subscribed, together with such large annual contributions that, after building and equipping the hospital, an income of £12,000 a year is already assured for research.

The largest contributions to the hospital have come from Indian rajahs and merchants, and those for research from English business men and firms, including very liberal support from Sir David Yule and Sir Dorab Tata. Seven whole-time research appointments, two of which are held by Indian research scholars, are being financed from this fund under a committee of medical men. As each worker has one or more qualified Indian assistants, the total staff will number forty-two, while the completed laboratories consist of four floors, with 220 ft. of north light, connected by a small foot-bridge with my former laboratory and museum, giving a total north front of 400 ft. I mention these facts to show what Calcutta has done for tropical medicine, and will only add that in my appeal I asked for money as a business proposition, and was able to persuade many of the donors that it would pay them to give money to investigate the tropical diseases such as

ankylostomiasis, which so severely handicapped their labour forces. Another school on similar lines has also been organized in Bombay by my friend Lieut.-Colonel Glen Liston, I.M.S., which, together with the four hill-top laboratories of the Bacteriological Department of the Indian Medical Service and the Pathological Laboratories of the Medical Colleges, will place India in the forefront of research in tropical medicine.

Having thus been privileged to have a share in the organization of medical research work in India on practical lines, with the closest possible relationship between clinical and pathological work—an important point which, I venture to think, is not always sufficiently borne in mind in this country—I cannot help inquiring whether sufficient provision for similar work has yet been made in other British tropical possessions, and, if not, what steps are necessary to remedy such a serious deficiency. Something has, of course, been done in the last two decades, with practical results which should surely lead to world-wide further efforts in this direction, such as the discovery of the cause and means of prevention of beri-beri in the Malay States, where the Kuala Lumpur laboratory has furnished such good work; the Wellcome Laboratory of Khartoum under Balfour, from which town Christopher-son's tartar emetic cure of bilharzial disease has emanated; the valuable work of the Queensland laboratory under Breinl, and that of Macfie in West Africa, where the Sir Alfred Jones Tropical Laboratory is being built at Sierra Leone. But what are they among so many, save as crying appeals to the wealthy to emulate the example of such practical philanthropists as Mr. Wellcome and Sir Alfred Jones? I understand that such an important colony as British East Africa (to mention only one striking example), where white men can flourish and many of our out-of-work soldiers might well find a livelihood with some initial help from Government, has neither laboratory nor research worker, although the neighbouring Uganda Protectorate is slightly better off.

A few months ago I received an invitation to join an influential Committee for the Prevention of Tropical Diseases, but on learning from their circular that they proposed to spend £50,000 on a single expedition to a very small and rather healthy (because malaria-free) West Indian island, I felt obliged to decline the invitation as I could not agree with such a policy. But I intimated that should they at any time alter their policy to one of organizing permanent research laboratories in various British tropical possessions I would gladly do anything I could to help them, and that is the policy I now desire to put forward for the consideration of those interested in the progress of tropical medicine. The Liverpool school have already given a lead in the right direction by establishing research laboratories at both Sierra Leone and at Manaos, in Brazil, and I trust that the much more wealthy City of London will not lag behind in such practical work, but will find liberal sums to enable the London School of Tropical Medicine, if they approve of the policy I suggest, to found research laboratories in British East Africa and other British tropical countries which are at present without such vitally important institutions. If money is forthcoming, and the support of the Colonial Office can be obtained, I would suggest that annual contributions towards the support of a research worker for a limited number of years should be offered to selected British colonies on condition that the local authorities supplied a small and unpretentious laboratory to start with immediately adjacent to the largest available hospital, and I have no doubt whatever that, after five years' experience of the benefits derived from it, they will be only too glad to grant it full permanent support, thus setting free the home grant for similar use in some other country. It should be a condition of the grant that the organizing committee should have a say in the appointment of the investigator, to ensure the right man being obtained for the critical first five years, which should, I suggest, be the shortest time any research worker should go abroad. This plan would in time assure all important British tropical possessions obtaining permanent laboratories and research workers, while it will still be possible, and occasionally advisable, to send temporary expeditions of specially qualified investigators to tackle some urgent problem due to an epidemic disease or an especially technical problem such as schistosomiasis was but a short time ago. The old policy of trusting entirely to temporary inquiries, with heavy costs for equipment and passages, and leaving no permanent organization behind the pioneers to carry on the work they have begun, should be abandoned as far as possible.

I trust I have made it quite clear that I am not criticizing the earlier policy, which was doubtless correct in the first stages of the evolution of our home schools of

tropical medicine, but I do wish to suggest, in the light of my long Indian experience, that the time has come for the further advance I have indicated. Indeed, I think this has been necessitated by the very success of recent researches in this field, including all the work done on dysenteries during the war, for now so many of the simpler problems have been solved the remaining problems of tropical medicine will require much more prolonged and detailed inquiries, including team work, such as is being provided for in the Calcutta school, the liberal public support, of which would serve as a stimulating example to London philanthropists, and especially to those whose firms or companies trade with tropical countries. Their young assistants have to live in such climates exposed to unnecessary dangers to their health from the lack of the safeguards provided by research laboratories, and I appeal to their employers for support for the proposals I have ventured to bring forward.

PREVENTION OF VENEREAL DISEASE.

At a conference on the prevention of venereal disease, under the chairmanship of Lord ASKWITH, on March 1st, Dr. MEARNS FRASER, M.O.H. for Portsmouth, proposed:

"That, in view of the terrible effects of venereal diseases on the health of the nation, and especially because of their effects upon women and children, there is urgent need for health authorities to institute active measures to protect the inhabitants of their districts against these diseases. Of these measures, by far the most important is education of the public as to the dangers of venereal diseases, as to the manner in which they are spread, and, above all, education in the methods of immediate self-disinfection, by which venereal diseases can be largely prevented."

He said that the Society for the Prevention of Venereal Disease was anxious to induce local authorities to make known the methods of self-disinfection to the public. He considered the time was ripe for local authorities to take action on the lines adopted by Portsmouth. The resolution was seconded by Dr. CHARLES SAUNDERS, M.O.H. for West Ham, who said that there were resolutions on the minutes of the West Ham Council approving of the education of the people in immediate self-disinfection.

Dr. E. W. HOPE, M.O.H. for Liverpool, stated that he was heartily in accord with the views expressed by Dr. Fraser, and gathered that, when emphasizing this aspect of the question, other aspects would not be lost sight of. He thought that those who raised objections from the moral standpoint seemed to forget that no obstacles were being placed in their way.

The MAYOR OF PORTSMOUTH said that the inhabitants of Portsmouth had all now come round to Dr. Fraser's way of thinking, and he had had all the support which any medical officer of health could wish for on this subject.

Dr. BOND, M.O.H. for Holborn, said that Holborn was the first London borough which had adopted the method advocated by the Society for the Prevention of Venereal Disease; he considered this method of education exceedingly simple and very inexpensive. Dr. HOLBOYD, M.O.H. for Chatham, said that when he brought the question of education and immediate self-disinfection before his Health Committee it was unanimously supported by them, and there was not a single dissident, nor were any dissentient opinions expressed in the town.

Mr. THOMPSON, Chairman of the Health Committee, Liverpool, said that during the past year they had had 78,000 attendances at the Liverpool venereal clinics, and emphasized the necessity for continuity of treatment. Mr. WILTWORTH, Chairman of the Bedfordshire Venereal Disease Committee, considered it necessary to amend the Venereal Disease Act, 1917, so as to enable anyone to go to a chemist and ask for what he wanted.

The resolution was supported also by Dr. J. B. HOWELL, M.O.H. for Hammersmith, and Dr. VEITCH CLARK, M.O.H. for Croydon.

The CHAIRMAN then submitted the following addendum to the resolution:

"Resolved further that this resolution and opinion be forwarded to health authorities throughout the United Kingdom, with the request that they take the subject at once into consideration."

With this addition the resolution was then put to the meeting and carried unanimously.

Lord WILLCUGHBY DE BROKE, President of the Society for the Prevention of Venereal Disease, moved a vote of thanks to Lord and Lady Askwith. Dr. WANSEY BAYLY, the Honorary Secretary, who seconded, said that he had just received a telegram from Dr. J. Priestley, M.O.H. for Lambeth, expressing cordial support of the resolution, and that Colonel F. E. Fremantle, M.P., President of the Society of Medical Officers of Health, had intended to be present, unless prevented by parliamentary duties.

OWING to the increase of poverty in Austria, an insurance society has been founded at Vienna for members of the middle classes under the name of the "Yellow Cross." Those insured have the right to choose their doctor, and in operation cases their surgeon, as well as their hospital or nursing home.

MOTOR NOTES FOR MEDICAL MEN.

BY H. MASSAC BUIST.

MINISTERIAL AND COMMERCIAL ASPECTS.

It is not good news that the Ministry of Transport, which has scarcely been got into working order, is to lose its head, Sir Eric Geddes, next summer. Whether the Ministry itself is to lapse is apparently still undecided. In all likelihood its functions will be absorbed by one of the older ministries. This at least is certain, that once a Government has regarded the question of internal transport as a national affair it will not be allowed to revert to the condition in which it was the sport of local authorities. All that motor owners and builders can do in the meantime is to be forewarned that a very sharp look-out will have to be kept on the money raised from them by way of taxation. Unless we see to it very carefully an increasing portion of the net sum raised from motor taxes will begin to be diverted to other ends. Already there are signs that at no distant date the bulk of the motorists' money spent on the roads will not be employed to give us twentieth-century highways and byways for twentieth-century traffic, but merely to patch up and keep going obsolete systems; in other words, to pursue the work of maintaining unsuitable road types which, among other things, are enormously wasteful when employed for latter-day traffic. In the current year far too small a proportion of the money is being spent on that work of permanent road improvement which should be the main objective of all endeavour. There are indications that that work may be so limited in ultimate scope that, in relatively a few years, all that will be held necessary will have been accomplished in that connexion; apparently the idea is that the total amount of funds then supplied yearly by motorists by way of taxation will be employed solely for maintaining the highways and not to remodel them. This should not be allowed. Among the points that concern motorists and are under consideration by the Government at the moment, is the question of the left-side drive. It has been condemned by many coroners throughout the country as being dangerous. It cannot be said that anything has happened this year which has not tended to confirm that danger, particularly as concerns the use of left-side driven vehicles wherein the driver is enclosed by coverd work. The draft of the promised new bill to deal with speed on the highroads and so on will either undergo modification before introduction to the House, or it will prove a very unpopular measure there.

PRICES.

The first motoring development of the year has been the inevitable and long-expected campaign of price-cutting, chiefly on the part of those who have produced car types which are little better than furnished up pre-war models. This move has been countered by those who produce cars for which there is a demand. Such firms have given undertakings to the effect that, should there be any fall in the price of their vehicles as between now and June or July, as the case may be, any buyers placing orders to-day will receive a rebate of any such difference in price. But it must be understood clearly that it is impossible for the cars which are in most demand to be sold at lower prices than are ruling. Already the price of many of them is too low from the point of view of the accountants of the manufacturers. Moreover, where genuine post-war designs are carried out with post-war material and by post-war manufacturing methods it is not possible to reduce prices, though these may appear dear. The reason is that such designs call for very expensive methods of production with the view to making motoring more economical. This was admirably illustrated last week when Vickers' motor manufacturing concern, the Wolseley Company, invited the Press to inspect its works after an interval of seven years. During that period the original shops at Adelerley Park, Birmingham, have been expanded to a floor space of thirty three acres, and entirely new works for the production of the 10-h.p. four-cylinder, overhead valve engine, three speed Wolseley (ex-Stellite) car have been set up with a floor space of sixty-six acres at Ward End, a couple of miles away from the parent shops. Though at the first glance the machines are apparently not cheap, a consideration of

the quality and features embodied in them reveals that they can compare favourably with the cheapest home or foreign-produced vehicle under the heading of bare cost at the end of two years. That is to say, real post-war designing ensures a big economy in running and maintenance costs.

REAL MOTORING ECONOMY.

In the case of the 10-h.p. car the tax is about £11 a year, yet each engine has to pass a bench test of 24.25 h.p., and with such a vehicle it is possible, without ever exceeding forty miles an hour, to average thirty-two miles an hour from point to point in long runs when driving in an ordinarily cautious way and without "hunting" the car. These engines are guaranteed to give thirty miles to the gallon of fuel, and I make bold to foretell that within six weeks the cars will be selling with a guarantee that the engine will accomplish forty miles to the gallon. Thus the owner saves both in petrol, which is costly, and in engine tax, which is a substitute for the petrol tax obtaining last year. How this is done may be illustrated by taking the mean effective pressure of this engine compared with the average of standardized type. The mean effective pressure means the motor fuel supplied to the engine and turned into horse-power. In the case of the popular American type of car a mean effective pressure figure of 78 is about the average, and 85 would be a fair figure for most British and Continental standard cars, whereas in the case of the Wolseley post-war engine it is 110, a figure better than was obtained with the former cars specially built for the Tourist Trophy Races before the war. It is, however, one thing to aim at employing a much better engine—in which connexion the firm has just standardized battery ignition sets for these types—and quite another matter to evolve such an entirely new chassis as shall represent a car which is 100 per cent. post-war design, instead of merely placing a post-war type of engine in a pre-war chassis. The Wolseley coachwork, as well as the chassis, is made on new lines. In this little car the back axle and the engine form in effect the frame of the vehicle. Another point about which the non-technical are often puzzled is how a machine having quarter elliptic front springs and no radius rods would fare in the event of the main leaf of a front spring breaking. A glance at the construction employed will reveal that there is a short dummy leaf with an eyelet hole underneath the main spring leaf. This dummy leaf does no work when the car is in normal condition. But the eyelet hole of this abbreviated dummy undermost leaf is attached to the shortest and uppermost spring leaf proper by a shackle. Thus it is possible to saw through the leaves of the spring—I doubt if they have ever been broken, for they are proportionately strong—and still drive at forty miles an hour with perfect safety with a spring thus artificially broken. This simple detail is the subject matter of a master patent, a fact of which some rival manufacturers appear to be unaware, in that they are standardizing this so simple and effective solution of a very difficult engineering problem.

THE SCIENTIFIC USE OF PLANT.

This car, together with the 15-h.p. £16 tax model, the engine of which is tested to give 45 to 46 h.p., is of particular interest to the medical man by reason of the low running costs. The springing system common to both results in a set of tyres being good for at least a year's work under average conditions. The economy, without sacrifice of the distinctive qualities of rapid acceleration and good hill-climbing, is accounted for mainly by a combination of three factors. The first is the even torque of the engine at all speeds and loads, for these are very high-grade engineering constructions; the second is the smoothness of the clutch and of the worm drive; and the third, of course, is the exploitation of the special form of springing which is perpetually plangent, and with which it is impossible to get a jar, the most that can be experienced being a plunge. The wheels follow the contour of the road, so do not jump and spin, with consequent grinding. Throughout the engine and the chassis of both types workmanship to exceedingly close limits is made possible by the war experience, which, in part, is continued by the Wolseley production of screw gauges, not merely for its own works but practically for the supply of the entire British industry and for export. Every one of those

gauges is made by a girl at a machine a little larger than a sewing machine, yet every gauge so produced has to pass the National Physical Laboratory tests, which require it to be accurate to within one ten-thousandth part of an inch in each of seven elements in which it is measured photographically. In short, there is here no manufacturing of cars by hand. Every part of the work is sectionized. There are two laboratories on the establishment, for, apart from that concerned with experimental work, every piece of raw material used is tested. Judged by the pre-war scale of British motor production the experimental department itself would be quite a considerable factory. Practically every make of car in a range between 8 h.p. and 50 h.p. is tested, so that the data obtained in connexion with it are available in comparative form.

100 PER CENT. EFFICIENCY.

The firm does its own stamping. In these vast factories there are made not merely the aluminium, but the steel castings for cylinders, and for every part of a car which is ordinarily bought from outside, including, for example, the back axle details. By the multi-jig principle it is possible to machine a couple of dozen crankshafts in synchronism to the gain of absolute standardization as well as of great economy, because by that means 100 per cent. cutter efficiency is obtained; that is to say, instead of only a twenty-fourth of the total movement, every inch of the travel of the machine under the tool produces cutting. In the huge pressing department approaching completion at a cost of £120,000 odd it will be possible to reduce by one-tenth the combined cost of materials and labour for a set of wings for a car. This plant, besides, will press under pans for chassis, body panels, and so forth. A track assembly system is available when wanted. But the firm has not yet accelerated to full time, though it is turning out 150 cars a week already, for every one of which a retail purchaser has been secured by one of the firm's agents. The delay in the production programme is due to the disastrous effects of the twenty-two weeks' moulders' strike, which cost a full year's output, because such a dislocation is always of much longer duration than the prime cause of it. The capacity of the Ward End works for turning out the 10-h.p. Wolseley car is 10,000 cars a year. If a night shift is put on in the machine shop, between the two factories it will be possible to turn out, among the three models, 24,000 cars a year; there is a 20-h.p. six-cylinder side-valve engine type. The normal day shift production of the two factories is 12,000 cars. The organization is such that output can be accelerated very rapidly now. On the other hand, it is not necessary to accelerate beyond the present output should the Government be able to do nothing in regard to the exchange situation, which is handicapping foreign trade.

The 10-h.p. model is made with a two-seater coupé body as a permanently closed car, which is, nevertheless, airy in warm weather. A two-seater model on the same type of chassis is furnished with Cape cart hood elaborated on such a scheme that, in bad weather, a doctor can make a completely and effectively rainproof motor-carriage of it. The firm announces that there can be no price reduction this year; but it undertakes to prove by figures that its car can compete favourably on combined purchase and running cost on a two years' running basis with any vehicles in the market. Of course, at the end of two years a machine made to such very fine limits of materials of such quality would be practically none the worse for wear; whereas the life of most cheap-for-their-size cars is brief. An interesting sidelight is furnished by the fact that one of the largest and foremost engineering houses in Japan has taken out a licence to make these cars, the patent laws of that country rendering that the only means of safeguarding such unique constitutional features.

As illustrating incidentally how closely the prices of the highest classes of small cars are coming to those of the best quality motor bicycle and side-car outfits attention may be drawn to the announcement that the Rover Company has reduced the price of the 8-h.p. twin-cylinder air-cooled Rover car complete from £300 to 250 guineas. This is a vehicle with motor cycle scale of tyre upkeep and fuel consumption, yet with the advantages of a car from the points of view of sitting accommodation, protection against the elements, the possession of three forward speeds, worm drive, plate clutch, and plangent quarter elliptic fore and aft springs.



The Royal Victoria Infirmary, Newcastle-upon-Tyne. (Photograph taken from the Leazes Park.)

EIGHTY-NINTH ANNUAL MEETING of the

British Medical Association, NEWCASTLE-UPON-TYNE, 1921.

SOME OF THE TOWN'S INSTITUTIONS.

UNIVERSITY OF DURHAM COLLEGE OF MEDICINE.

A SCHOOL of medicine has existed in Newcastle since 1832, when the Newcastle-on-Tyne School of Medicine and Surgery was formed by a few local medical men, with the brothers Fife as prime movers. There were at first only nine students, and the lectures were given in a room in Bell's Court, Pilgrim Street. After two years the founders, feeling the need of better accommodation, and emboldened by the success of their first two sessions, rented the Hall of the Worshipful Company of Barber-Surgeons together with Wax and Tallow Chandlers, in the Manors. The Hall itself was destined for the museum, and the space below was partitioned off and fitted up into a lecture room, a chemistry and materia medica room, and a dissecting room.

Down to 1851 the school grew and prospered; then, owing to violent dissensions among the staff, two rival schools were started. That of the majority in 1852 became associated with the University of Durham, and was known as "The Newcastle-on-Tyne College of Medicine in connexion with the University of Durham." Students were now enabled to proceed, first, to a licence in Medicine, and secondly, later, to the degrees of Bachelor and Doctor of Medicine. In the previous year the school had been recognized by the Society of Apothecaries of London and by the Royal College of Surgeons of England. By this time the old building at the Manors had to be demolished to make way for the extension of the North-Eastern Railway. New premises were built in the gardens of Westmorland House, near the Library of the Literary and Philosophical Society; this became known as the Orchard Street School of Medicine.

The minority of the lecturers formed a school entitled "The Newcastle-upon-Tyne College of Medicine and Practical Science," which was housed in the new Barber-Surgeons' Hall, still to be seen at the top of Westmorland Street. After working separately for some six years a reconciliation was brought about, and the two schools amalgamated to their mutual benefit. The incident of the disruption would probably have long been forgotten had the memory not been perpetuated in the humorously satirical ballad entitled, "The Knights of St. John and the Cross, or the Raid o' the Auld Musee," which records

in some fifty stanzas how the "minority" surreptitiously removed some of the best specimens from the stable in which the "majority" had temporarily housed the museum. In 1870 a still closer union was formed with the University, and the College has since been known as "The University of Durham College of Medicine."

Owing to the further exigencies of railway development, Orchard Street had to be vacated in 1889, and the present college in Northumberland Road, a photograph of which is here reproduced (p. 392), was opened.

In 1906 the building was greatly enlarged and improved by the addition of the Heath Wing, which was erected from funds left by Dr. George Ycoman Heath, who was President of the College from 1874 until his death in 1892. During the last twenty years the work of the College has greatly increased, and the number of students has gone up from an average of 200 to no less than 433 at the present time, and of this number seventy are women.

ARMSTRONG COLLEGE.

The subjects of chemistry, physics, and biology are taught at Armstrong College, which, with the College of Medicine, goes to form the "Newcastle Division" of the University of Durham. This institution was founded in 1871 as a science college, but its scope has been greatly extended, and it now includes faculties of arts and of commerce.

The work of the College is conducted in twenty-three teaching departments, of which perhaps pure Science, Mining, and Agriculture are the most important. In association with the latter is the experimental station at Cockle Park, and the practical Forestry Department at Chopwell Woods. As befits a shipbuilding district, the College contains an important department of Naval Architecture, one of the three which exist in the country. The Art Department is well attended, the work being carried on in the King Edward VII School of Art. The Department of Commerce is a comparatively recent addition, but is becoming increasingly important. In 1920 the number of students on the books of the College was 1,174, and many had to be refused admission. Unfortunately, both the University Colleges find themselves in sore need of additional funds, and they are at present appealing to the public for half a million pounds; of this sum about £150,000 has so far been subscribed or promised.

THE ROYAL VICTORIA INFIRMARY.

The Newcastle Infirmary was founded in 1751, being built in the period which saw the inception of so many of our provincial hospitals. When the project was first mooted it was taken up so enthusiastically that, rather than wait for the completion of the new building, a house in Gallowgate was used temporarily. The original infirmary, which was opened for patients in 1753, contained ninety beds and appears to have been a severely plain structure, with no needless ornamentation. With its additions of later years, the building still stands near the Central Railway Station:

Grim Lazaretto, deserted and still.
The birthplace and cradle of surgical skill!

The accommodation was fully utilized from the beginning, 500 to 600 patients being admitted each year, and there were frequent complaints of overcrowding. The original staff consisted of four physicians and two surgeons: the number of surgeons was increased to four in 1760 and to six in 1920.

In 1803 the building was reconstructed and enlarged to contain 100 beds. During 1801 the in-patients treated numbered 643

and by 1830 this number had increased to 1,000, so that the extension was not keeping pace with the needs of the district, and overcrowding was still prevalent; accordingly, 22 beds were added by the addition of a third story; the relief of pressure thus obtained was, however, of short duration, and in 1850 a new wing was begun to provide 144 more beds. Three years later epidemics of typhus and cholera broke out in Newcastle and the new wards were brought into use whilst the wing was still in an unfinished state. The in-patients rose to 1,679 annually, but the increase was greatest amongst "casuals"; their number rose to 16,000 in 1870. Fifty more beds were added in 1885, and about this date the constitution was altered in several ways. The Infirmary was made free—that is, letters of recommendation were no longer required for admission; the House Committee and medical staff were amalgamated, and workmen governors were appointed from those works which contributed to the funds.

In the last years of the last century it became obvious that the building was unable to cope with the needs of the district; overcrowding was often acute. Several plans were brought forward for a new building, and finally, in 1896, a public subscription was opened for this purpose to commemorate the Diamond Jubilee of Queen Victoria. Plans were prepared and a site selected after some delay, and with this public subscription, together with two munificent gifts of £100,000 each from the late Mr. John Ha'nd and Lord Armstrong, the present building was erected. The foundation stone was laid in 1900 by H.R.H. the Prince of Wales, and in 1906 the building was formally opened by him when King Edward VII. The hospital is on the pavilion system, with original accommodation for 400 patients. A central corridor traverses the building, which has the Nurses' Home (for 100 nurses) at its upper end and the out-patient department at its lower. Leading off this corridor are ten pavilions, of two stories, making twenty



The University of Durham College of Medicine, Northumberland Road, Newcastle-upon-Tyne.

wards, each a complete unit, with ward, kitchen, scullery, day room, linen room and sister's room. The administrative block is in the centre, and comprises entrance hall, library, board room, general offices and resident staff quarters. The out-patients' department consists of a central waiting hall, around which are consulting and examination rooms.

During the war additions were made, two surgical wards and a large skin department being provided—the accommodation was thus increased to 550 beds. The latest addition is the large Orthopaedic Hospital, which adjoins the Infirmary, and which at present, with huts, contains 500 beds more. This was built mainly by public subscription, but with assistance from grants from the Government, Red Cross Society, and relief funds for the treatment of "soldiers, pensioners, and civilians." It is at present under the charge of the Ministry of Pensions, but at the expiration of the Ministry's lease will revert to the Infirmary.

Again the Infirmary is proving far too small for the needs of the district. In 1919 the number of in-patients treated was 9,551 and 72,429 new out-patients were registered, with an aggregate of 160,151 attendances. The

waiting list, then over 1,300, is still growing, although the beds are being used to their utmost capacity.

Among the other medical institutions in the town are the Children's Hospital, the Lying-in Hospital, the Eye Infirmary, the Throat and Ear Hospital, the Skin Hospital, and the Dispensary.

LITERARY AND PHILOSOPHICAL SOCIETY.

This institution, familiarly known as the "Lit. and Phil.," appeals to a wide range of taste and attainment in matters

intellectual. Lectures by specialists are provided on all sorts of subjects, including some systematic educational courses. Occasionally lectures in French and German are given. But its crowning usefulness and popularity lies in its large library, which has been accumulating since its foundation, and which ranges from recondite volumes in literature and science to the most ephemeral fiction. Members roam at will among the hundreds of well-filled shelves and pick and choose whatever they wish to peruse in the comfortable reading room. The leading magazines and periodicals are also provided, and all may be borrowed under suitable regulations. The Society was founded in 1793, and the present buildings were opened in 1825. But previous to the definite foundation of this Society, there existed a society which may be looked on as a tentative effort towards the goal subsequently reached. The Philosophical Society, which was founded in 1775 and devoted itself to discussions, had but a brief existence. One of its members, Thomas Spence, was much in evidence in his day. He was a schoolmaster who advocated communal property in land, and invented a phonetic system of spelling, of which the following is a specimen:

"It may hile perpleks a karlls redir ov nu karaktirs too disifir the tru sens thereov: tho it shud be eze enuf too no it bi a lital aplekashin and praktis."

A fighting man was Spence, and having violently upbraided Thomas Bewick for not supporting him in a

debate, he received a good cudgelling from the famous engraver. He subsequently removed to London, where he was frequently in conflict with authority.

The idea of founding a medical school in Newcastle first originated with a distinguished member of the "Lit. and Phil," Dr. Greenhow, who endeavoured to arouse interest in the project by reading a paper before the Society dealing with the matter as early as 1831.

THE HANCOCK MUSEUM.

This museum, owned and maintained by the Natural History Society of Northumberland, Durham and Newcastle-upon-Tyne, is housed in an imposing building finely situated to the north of Barras Bridge, a centre with which the members attending the Annual Meeting will quickly become familiar. Of its contents, more particularly interesting are the Hancock collection of birds; Thomas Bold's Northumbrian insects; the herbarium of N. J. Winch; and collections of fossils from the local coal measures. The ethnological collection is notable not so much for its great extent as the unique interest of many of the objects, some of them brought back by Captain Cook's expeditions, and therefore before the age of faking and wholesale imitation. The Museum also contains a splendid collection of the original drawings and woodcuts of Thomas Bewick, the famous Newcastle engraver.

Those who are interested will find in the Free Library in New Bridge Street, and adjoining the Laing Art Gallery, a unique collection of Bewicksoniana known as the Pease bequest. The site of the house in which the engraver lived and worked is marked by a bust in the wall of Milburn House, adjoining the south side of St. Nicholas's Churchyard.

THE LAING ART GALLERY.

This gallery, in Higham Place, three minutes' walk from the College of Medicine, is a recent addition to the attractions of the city. Due to the munificence of the late Mr. Alexander Laing, it fills a want that had been long

experienced. The building, which is in the Renaissance style, reflects the greatest credit on the architects, but from the outside cannot be adequately appreciated owing to the narrowness of the street. The interior is appropriate to its purpose, and the visitor at once feels himself in the fitting atmosphere for a picture gallery. Already the permanent collection is quite considerable, and excellent examples of most of the leading modern painters are to be found on its walls. To mention a few—Edward Armitage, Frank Braugwyn, H. P. Briggs, A. K. Brown, George Clausen, H. H. Emerson, Stanhope A. Forbes, G. C. Haite, Chas. Napier Honey, Niel M. Lund, J. F. Lewis, H. H. La



Armstrong College, Newcastle-upon-Tyne

Thangue, George Wetherber, J. W. Waterhouse, Thomas Miles Richardson (senior and junior), Edward Richardson, Sir J. Noël Paton, J. W. Oakes, and A. Wakin Nicol are represented. There are always some pictures on loan from the National Gallery, and from time to time exhibitions of the work of local artists are held.

[The photographs are by Messrs. Jas. Baron and Sons, Newcastle-upon-Tyne.]



The Hancock Natural History Museum.

The provisional programme, so far as arrangements have already been made, for the Annual Meeting at Newcastle was published in the SUPPLEMENT of March 5th. The list of Officers of Sections was complete save for the Sections of Oto-Rhino-Laryngology and of Radiology and Electro-Therapeutics. The Officers of these

two Sections have now been appointed as follows:

Oto-Rhino-Laryngology.

President: G. WILLIAM HILL, M.D. *Vice-Presidents:* JAMES DON, M.D.; R. GORDON BELL, M.D.; DAN MCKENZIE, F.R.C.S. Edin. *Honorary Secretaries:* LIONEL COLDFE, F.R.C.S. (22, Queen Anne Street, London, W.1); W. FRANK WILSON, M.B., B.S. (97, Jesmond Road, Newcastle-upon-Tyne).

Radiology and Electro-Therapeutics.

President: WILLIAM IRONSIDE BRUCE, M.D. *Vice-Presidents:* W. HOPE FOWLER, F.R.C.S. Edin.; ROBERT EDWARD HOWELL, M.B., C.M. *Honorary Secretaries:* JAMES METCALFE, M.D. (123, Harley Street, London, W.1); THOMAS LOWE BUNTING, M.D. (6, Portland Terrace, Newcastle-upon-Tyne).

British Medical Journal.

SATURDAY, MARCH 12TH, 1921.

A PSYCHIATRIST'S REVIEW.

THE Physician-Superintendents of what is now known as the Royal Edinburgh Mental Hospital have accustomed us to expect that their annual reports shall partake rather of the nature of disquisitions on current psychiatric topics than detailed statistical statements. We propose here to make some comments on three topics, of interest alike to the profession and the public, dealt with by Dr. George Robertson in his report for 1920.

Some five-and-twenty years ago the late Sir Thomas Clouston, then physician-superintendent, induced the managers to build a hospital on a fine site in the outskirts of Edinburgh for the reception of private patients; the success of this hospital—Craig House—has surpassed the highest expectations of those who promoted it. Of the 126 patients admitted last year to Craig House no fewer than 66, or more than half, entered as voluntary patients. The procedure is simple: an application is made to the physician-superintendent in writing, who, if he thinks proper, admits the patient, and a similar application is sent to the Board of Control, which gives its sanction without further formality should the application be clear and unambiguous. The whole amounts to little more than notification. Dr. Robertson asks, "if the majority of patients of the richer classes are prepared to enter a mental hospital voluntarily for early treatment and without certification, and if their financial and other interests are sufficiently safeguarded by a formality which resembles notification," why should not similar facilities be available for the poor? At present the only course open, even in Scotland, to a person afflicted in mind, and not endowed with wealth, is to submit to certification as a lunatic and to be committed under an order granted by a sheriff. It is, Dr. Robertson says, useless in these circumstances to hope for the adoption of early treatment; he thinks that the Act of 1857 should be amended, and that the financial difficulty would be overcome were the Government grant in aid, given to assist in the maintenance of certified parochial patients, also given for voluntary parochial patients. Another but much more expensive plan by which early treatment can be obtained in Scotland is by temporary residence in a nursing home. This plan, it would appear, is approved by the Board of Control, for Dr. John Macpherson, one of the medical commissioners, in his address at the celebration of the centenary of the Dundee Royal Asylum, said: "We are inclined to think that adjunct houses, in which patients afflicted with certain forms of insanity could be received without the strict legal formalities at present recognized, would prove a beneficial modification of our asylums." The managers of the Edinburgh Mental Hospital are in sympathy with this proposal; they have already established two such houses or homes, and hope to open a third this year.

The second topic of general interest discussed in Dr. Robertson's report is the policy of the temperance party in Scotland in seeking to secure total prohibition of the sale of alcoholic beverages when the vote

under the Scottish Temperance Act was taken last year. As will be seen from the table reproduced on p. 401, the percentage of admissions to the Edinburgh Mental Hospital in which alcoholic excess is believed to have been the exciting cause has progressively declined in both sexes since the beginning of this century; alcoholism was less frequently assigned as a cause among women than among men, and the decline among them has been very remarkable. In the seven years before the war alcoholic excess was given as the exciting cause, on the average, in 9.6 per cent. of the cases in women; in the following seven years the average was 2.6; last year the percentage was only 1.0. It is pointed out that the number of cases of insanity alleged to be due to alcoholic excess is little more than a rough means of gauging the amount of excessive drinking in a community. "It only represents a fraction of the evil done to the nation by intemperate habits, just as the number of balls that find their way into the Swilcan Burn would represent a fraction of the bad play over St. Andrews Links." Still Dr. Robertson is not prepared to prescribe total prohibition for all, and in this he undoubtedly shares the opinion of his predecessor, Sir Thomas Clouston. "A simple and direct procedure like prohibition," he says, "may appear to be a very obvious remedy for the evil, but we have been well warned by Herbert Spencer that in a complex organization like civilized society such interference often brings with it consequences which are worse for the social body than the disease it is intended to remove." Owing to this attitude Dr. Robertson is regarded by the temperance party as a source of weakness, in spite of the views he has expressed on the subject of excess. His retort is—if that party had been content to advocate a reduction of licences they would probably have been rewarded with success.

Dr. Robertson, it will be remembered, is Professor of Psychiatry in the University of Edinburgh, and the third topic of general interest treated in this report is psycho-analysis. The theory of repression he regards as the main pillar of psycho-analysis, and that, he holds, leads inevitably to the conception of an unconscious, yet active, mind, for the repressed subject, "though forgotten, is not annihilated. It continues to exist unconsciously, and this not in a passive state, but as an active, though unsuspected, force." Freud's work, he considers, is continuous with that of two great teachers of the Edinburgh school; thus the unconscious mind is but an elaboration of the psychological aspect of Professor Laycock's famous hypothesis of "reflex, automatic, or unconscious cerebration," applied by him to account for the phenomena of delirium, dreams, and somnambulism. The idea of repression was grasped by Sir Thomas Clouston when he wrote in 1880: "The intense and complete outward repression and inhibition of certain physiological cravings required by our morals and our civilization causes, no doubt, a dangerous strain on the brain functions and a reaction in other directions, where there are hereditary neurotic weaknesses." And in another place he said: "The psychological analysis of what female modesty is, by a physiologist, reveals the transformation and apotheosis in the higher regions of the brain of reflex impressions from the reproductive organs into a high moral quality, not only beautiful, but absolutely essential to social life." Professor Robertson then goes on to point out how the theory of conscious and unconscious forms of mental action is in accord with the views enunciated many years ago by Hughlings Jackson, that

the higher nervous arrangements were evolved out of the lower, and kept down or repressed the lower, just as a Government evolved out of a nation controlled as well as directed that nation. In dreams, the conscious level, tired by the day's work, is put out of action during sleep, and the lower unconscious level runs riot in primitive and illogical dreams and nightmares. In insanity the higher or conscious level is usually put out of action to a greater or less degree by obscure poisons, by exhaustion, or by both, and the patient suffers from dreams by day, or at least from delusions and "such stuff as dreams are made of." Professor Robertson, therefore, is grateful to Freud for what he has done to bring the working of the sound and unsound mind into line with and closer to one another. People, Professor Robertson thinks, are furious with Freud because he endeavours to make them realize the kinships of their own highly cultured minds to those of beings of a primitive, coarser, or inferior type, whether these be children, savages or animals. This aspect of the matter is fully discussed in the remarkable book on *Instinct and the Unconscious* by Dr. Rivers, which was reviewed in our columns of February 26th, p. 305. The causes of such "fury" as has been displayed are other.

TRINITROTOLUENE POISONING.

THE modern high explosive trinitrotoluene or trinitrotoluol—commonly called T.N.T.—is a fine crystalline yellow powder sometimes used by the shell filler in the form of fused yellowish-brown lumps. It is obtained by nitrating toluene—a product of coal-tar distillation. Before the war it was generally believed to be much less toxic than trinitrobenzene, which had been manufactured in this country on a small scale for many years. Indeed, until towards the end of 1915 T.N.T. was looked on as an innocuous substance which had never been observed to set up illness. In November, 1915, toxic jaundice was added to the schedule of diseases that have to be notified to the Chief Inspector of Factories by a Home Office Order, but this was because of the toxic jaundice which had occurred in various aeroplane factories from the use of tetrachlorethane (a constituent of the dope or varnish applied to the canvas wings of aeroplanes), the cause of which was first discovered in this country in December, 1914. In the latter part of 1915 a few cases of toxic jaundice due to T.N.T. poisoning were reported, and in 1916 and 1917 a considerable number of cases of undoubted poisoning occurred. The question whether the poisonous effects were due to trinitrotoluene itself or to impurities or admixtures with it was fully considered; the conclusion reached was that T.N.T. alone was the causal factor.

An interesting Report¹ has now been issued by the Medical Research Council on T.N.T. poisoning and the fate of this substance in the animal body. Dr. W. J. O'Donovan gives an account of the clinical symptoms occurring amongst workers in munition factories where T.N.T. and preparations containing it were used. The clinical effects included anaemia, dermatitis, gastritis, and toxic jaundice. The severe types of anaemia were of the aplastic type and no parallelism existed between the occurrence of toxic jaundice and fatal anaemia. The occurrence of dermatitis was of interest since the conclusion to which the work of Professor Benjamin Moore pointed was that the skin was the main channel of absorption. No connexion was established between the occurrence

of dermatitis and the two fatal manifestations of T.N.T. poisoning, toxic jaundice and aplastic anaemia. During the later stages of the war trinitrotoluene was largely mixed with ammonium nitrate for purposes of shell filling, as much as 80 per cent. of the latter being used, and this from its hygroscopic nature appeared to play an important part in the occurrence of dermatitis.

Toxic gastritis is described as of frequent occurrence; its relationship to toxic jaundice is not emphasized, though, from analogy with the tetrachlorethane cases, it seems likely that it would be an important premonitory symptom. Toxic jaundice appeared to occur more frequently in young adults, who when attacked were very prone to die, and in consequence employment in T.N.T. work of persons below the age of 18 was prohibited. The jaundice was associated in its early stages with enlargement of the liver and later with shrinkage, and it is interesting to note that ascites was observed in one case in which considerable shrinkage of the liver was found. A very important observation was the long latent period that might supervene between exposure to T.N.T. and the development of toxic jaundice. Dr. T. M. Legge recorded a case in which the latent period was seven months, and Professor Glynn one in which it was nine months. These observations are at the present time receiving confirmation from the long latent period that may intervene before toxic jaundice follows the administration of preparations of arsenobenzol, which are too often used with complete disregard for their effect on the liver cells. There seems to be no doubt that toxic liver poisons cause damage leading to ultimate necrosis of the liver parenchyma, and that a long latent period may supervene before a toxic jaundice, often of fatal type, occurs.

The animal experiments carried out by Dr. G. A. Wyon did not throw much light on the effects of T.N.T. observed in human beings. After doses relatively very much larger than those to which workers would be exposed, hepatic degeneration was produced in cats, rabbits, rats, and monkeys, but chronic poisoning with small doses did not cause it. In rabbits the administration of large doses of T.N.T. caused blood changes resembling an early stage of aplastic anaemia. The conclusion drawn from the animal experiments was that an unknown second factor probably co-operates with T.N.T. in the production of fatal forms of poisoning in man.

An interesting account of the metabolism and excretion of T.N.T. is given by Mr. T. A. Webster, to whom is due the discovery of the test for the detection of T.N.T. derivatives in the urine. It appears that the reduction condensation compound, azoxy-di-nitrotoluene, is formed, which is excreted in the urine in conjugation with glycuronic acid, and it is this substance which is detected by the Webster test or its modification by Tutin. Dr. Barbara Crawford, at the suggestion of Dr. O'Donovan, tested the effect of the application to the skin of an ointment containing 12½ per cent. of T.N.T. upon one of the patients suffering from toxic jaundice, with the result that no T.N.T. reaction was given by the urine, whereas in a control test on a healthy adult a definite reaction was given. It appears that in severe cases of trinitrotoluene poisoning there may be a failure to excrete the T.N.T. derivative in the urine, and it is therefore possible, as Dr. H. H. Dale suggests, that the absence of Webster's reaction in a person exposed to T.N.T. should be regarded as a danger signal.

Dr. P. N. Panton carried out careful investigations into the pathological changes induced by

¹ No. 58, Special Report Series, 1921. Price 3s. net.

T.N.T. in the human body, and Dr. H. M. Turnbull made very complete histological studies of the changes in the organs from cases in man and animals. The jaundice appeared to be a true toxic jaundice due to destruction of liver by the poison and not to be of haemolytic origin. The aplastic anaemia—the rarest and most fatal of the complications—was found to be due to a direct action of the poison on the blood-forming cells which thus caused a great reduction of the blood-forming marrow. It was not due primarily to haemolysis, though this occurred in the late stages of the anaemia. The blood picture was that of a progressive primary anaemia with high colour index.

The interesting question was considered as to whether progressive changes in the liver were set up in T.N.T. workers after their removal from the influence of the poison. In the severe cases of liver poisoning there was clear evidence of the occurrence of fatal toxic jaundice many months after removal from the influence of the poison, pointing to progressive degeneration of the liver. Where only minor liver damage occurred such evidence as was available suggested that this was recoverable and not progressive.

S. WEIR MITCHELL.

AFTER his death in 1914 the College of Physicians of Philadelphia, for which the late Dr. Silas Weir Mitchell did more than any other man of his generation, founded in his name and memory a triennial oration to deal with "the life and work of Weir Mitchell in their various aspects, or the relation of the physician to public life, or the physician in science or letters, or broad considerations of psychiatry and neurology, or surgery and military surgery in relation to morbid conditions and wounds and injuries of the brain and nervous system, or of scientific research, or medical books and libraries, or medical history and biography, and shall be, as far as possible, of general as well as professional interest." This long list well epitomizes the many-sided activities of his remarkable personality. The first oration, delayed by the war until 1919, was happily entrusted to Dr. C. W. Burr,¹ who reveals a literary gift of a high order, tinged with an attractive turn of gentle satire for the passing foibles of the younger generation. To Weir Mitchell and Sir William Osler the orator gracefully acknowledges his debt for influencing his intellectual life, and for teaching him the paramount necessity for intellectual honesty; it is accordingly with a pupil's reverence that he devotes the first oration to a description of Weir Mitchell as the physician, the man of science, the man of letters, and the man of affairs. The son of a scientific physician, he grew up in a medical atmosphere; otherwise it is probable that his natural inclination would have made him purely a man of letters. His early professional life was a struggle, for financial success was slow in arriving, but he filled in this probationary period by scientific research and did pioneer work on snake venom. The civil war provided him with opportunities for an extensive study of nerve injuries, and his great work, *Gunshot Wounds and other Injuries of Nerves* (1864), gave him a lasting reputation. Among his minor discoveries were the cremasteric reflex and erythromelalgia. His name became widely known in connexion with the rest cure; but, as Dr. Burr points out, it became too popular, and incompetent practitioners adopted it for patients who really were in need of a work cure. The first of his fifteen novels, *Hephzibah Guinness*, did not appear until he was 50, in deference to Oliver Wendell Holmes's advice not to jeopardize his professional prospects; and on this incident the orator remarks that "little-minded people are of the

fixed opinion that no one can have mind enough to do more than one thing." The medical man and the neurologist show up but little in Weir Mitchell's novels, save for the accurate descriptions of really diseased characters, though some of his writings, such as those on dreams and double personality, form a connecting link between science and literature. Dr. Burr suggests that the reason why no medical man of letters has ever succeeded in depicting a doctor is that it is analogous to writing his autobiography or painting his own picture from a mirror; prejudice makes him see what he wants to see. He agrees with Weir Mitchell that George Eliot's Dr. Lydgate is the best description in modern English literature, and dismisses Dickens's doctors as either mere caricatures or silly, sentimental, goody-goody men; he does not mention Thackeray's Dr. Goodenough, generally regarded as a portrait of Elliotson, but perhaps this is too shadowy a sketch. As a poet Weir Mitchell was eminently successful for special occasions, and wrote charming verses on the country. Always interested in physico-therapy he advanced its applications and rescued it from the hands of charlatans; he also took an active part in instituting schools for training nurses and in numerous other public movements. He died in his 85th year when still at work, and almost had the boon that all men should pray for—namely, sudden death. Dr. Burr's tribute may recall Sir William Osler's obituary remarks,² in the course of which he applied to Weir Mitchell the remark made by Samuel Johnson about Mead: "No man ever lived more in the sunshine of life."

INVESTIGATIONS INTO YELLOW FEVER IN MEXICO.

IN continuation of the researches into the etiology of yellow fever in Guayaquil which have been noted in our pages from time to time, making it highly probable that the causal organism is *Leptospira icteroides* and allied to the *Leptospira icterohaemorrhagiae* responsible for the form of infectious jaundice formerly termed Weil's disease, Noguchi, now in collaboration with I. J. Kligler,³ has investigated the disease at Merida, the capital of Yucatan, Mexico. During the four years previous to 1919 a systematic anti-stegomyia campaign kept this city free from yellow fever, but in that year, as a result of an enormous crop of stegomyias, there was an epidemic of yellow fever from July to November, with 100 cases among newly arrived troops, and a death rate of about 50 per cent. Arriving in December, Noguchi and Kligler found opportunities, in one fatal case, a case that recovered, and in convalescent patients, for scientific investigation. Blood drawn from the vein of a patient on the second and third days of the disease, directly transmitted the disease to guinea-pigs, and there were indications of abortive or mild leptospira infection in guinea-pigs inoculated with blood drawn on the fifth day of the disease. Dark-field search for the leptospira in material from the fatal case was negative, but cultures of blood taken on the second day of the disease showed the leptospira. The morphological features and cultural properties of the strain of leptospira isolated from yellow fever in Merida were similar to those of the Guayaquil strains. By means of an anti-icteroid serum, prepared by repeatedly injecting a horse with different strains of *Leptospira icteroides* from Guayaquil, it was shown that the Merida strain belongs to the same group as the Guayaquil strain. Multivalent anti-icteroid immune serum prepared in the horse or univalent anti-icteroid immune serum prepared in the rabbit had a definite devitalizing action on the Merida strain, whereas antisera similarly prepared with strains of *Leptospira icterohaemorrhagiae* did not have any perceptible effect upon the Merida strain. This observation is important not only in showing the relation of the Guayaquil and Merida strains, but also

¹ The S. Weir Mitchell Oration, delivered before the College of Physicians of Philadelphia on November 19th, 1919, by Charles W. Burr, M.D.; pages 31. Published by the College, 1920.

² BRITISH MEDICAL JOURNAL, 1914, i, 120.

³ H. Noguchi and I. J. Kligler, *Journ. Exper. Med.*, Baltimore, 1920, xxxii, 601-637.

in answering the criticism that "the yellow fever" in Guayaquil was really an infection with *Leptospira icterohaemorrhagiae*. Anti-icteroides serum protected guinea-pigs against infection, 0.1 c.cm. preventing fatal infection against at least 5,000 minimum lethal doses of the Merida strain, when given during the incubation period or at an early stage of the disease (fever and commencing jaundice), but being almost without effect at a later stage when the jaundice is deep and the temperature falling. If man's susceptibility to *L. icteroides* is comparable to that of the guinea-pig it may reasonably be assumed that intravenous injection of the serum at an early stage would have a similarly beneficial effect. A man weighing 80 kg. would require about two hundred times the amount of serum that a guinea-pig weighing 400 grams would, or 20 c.cm., and, if necessary, the injection should be repeated at intervals of four hours.

CATACLYSMAL HAEMORRHAGE AFTER TONSILLECTOMY.

BLEEDING of great severity is fortunately rare after tonsillectomy, and overwhelming haemorrhage leading to the almost instant death of the patient is amongst the rarities of medicine. A brisk arterial spurting from the tonsil-bed is not very uncommon, particularly in those adults who have a sclerotic, buried, tonsil. In such cases the vessel involved is commonly believed to be the ascending pharyngeal, or more rarely one of the other arteries which supply the tonsil, but abnormally placed or abnormally large. There are, however, in the archives of medicine, records of cases in which the haemorrhage was so appalling that one or other of the carotid vessels was believed to have been injured, no other regional vessel being thought capable of such violent bleeding. Fear of a disaster of this nature was well known to our fathers, and forms the background to a story told of Nélaton. A friend met Nélaton at some distance from Paris, and asked him what brought him thither. "I have just done the operation," he replied, "which takes most out of me. I have removed two tonsils." With this anecdote M. Sebileau¹ closes an exceedingly interesting description of an overwhelming and immediately fatal haemorrhage following tonsillectomy. M. Sebileau was not himself the operator. It was his duty to perform a necropsy on the child in question with a view to the absolution or arraignment of the surgeon. All who prize good writing, and particularly dramatic writing, may be recommended to read M. Sebileau's account of the operation and its sequels. The possibility of wounding either of the carotids has been doubted by many, and M. Sebileau went to considerable pains to establish beyond doubt the source of the haemorrhage in this case. He injected the two carotids and the internal jugular severally with three different coloured media and was able to show beyond all question that a piece had been cut out of the wall of the internal carotid artery. Precisely how this had happened, how the surgeon went blindly after the upper pole of the tonsil which had escaped removal, and how, hampered by the child's struggles, he cut away the posterior faucial pillar instead, is vividly described. The paper is well documented and contains a useful description of the relationships of the various vessels to the tonsillar fossa. M. Sebileau searched the literature of the subject and has found some eight or more recorded examples. It is not certain that in all of these the carotid was the vessel injured, but the violence of the haemorrhage makes this probable. M. Sebileau has collected also six cases of injury to the carotid inflicted whilst incising a tonsillar abscess. These accidents, when they do occur, are amongst the most painful disasters that can befall a surgeon.

MOTOR FUEL ECONOMY TRIALS.

THE Royal Automobile Club has now issued the regulations to govern its fuel economy trials to take place on the afternoon of Saturday, May 7th, with the object of demonstrating the possibility of obtaining greater fuel economy in the use of cars than is now general. Many private motorists claim to have effected noteworthy economies in fuel consumption, and it is hoped that the trials will give wide publicity to such results and the means by which they are achieved. The Club realizes that the trial will also afford a good opportunity of testing the claims made for the very large number of appliances for reducing fuel consumption that are on the market and concerning which, as has often been pointed out in our motoring notes, the only way in which they can hope to deserve attention is to submit them to official tests. The public has been invited from time to time to spend large sums of money on devices which, it is claimed, effect fuel economy, but in connexion with which it is practically impossible to point to any official evidence in confirmation of the alleged gain. It is therefore noteworthy that one of the regulations wisely allows the judges, when making the awards in connexion with the forthcoming R.A.C. trial, to take into consideration the selling price of any fuel economy device submitted, on the principle that there is no economic advantage in spending £5 to save, possibly, £4 10s. The rules are of a simple character, designed with a view to encouraging the entry of private car owners, who have already shown a considerable interest in the trial and to whom it makes an obvious appeal. A measure of miles per gallon has been chosen as the basis of award for the reason that it is well understood by everyone. In effect, the result will be equivalent to saying that a car of a given make and horse-power, with a complement of passengers, is capable of running efficiently so many miles on one gallon of spirits. That is precisely what the public wants to know. The trial itself will consist of a series of runs from various centres throughout the country, and the date and time have been chosen so that the trial may appeal to a large number of motorists who will be free then. In each locality the course will be a short one. The three classes are for cars not exceeding 12 h.p.; exceeding 12 but not exceeding 20 h.p.; and for those exceeding 20 h.p. R.A.C. rating. These tests cannot be regarded as exhaustive or final. Rather would their usefulness seem to lie in their serving the purpose of eliminating trials of fuel economizers. We should learn which methods and devices are worthy of submission to really searching tests.

THE MEDICAL SOCIETY OF LONDON.

THE 148th anniversary dinner of the Medical Society of London was held at the Wharfedale Rooms on March 8th, with the President, Sir William Hale-White, in the chair. In proposing prosperity to the Society, the President traced the origins of medical societies, and remarked on the widespread desire that showed itself during the eighteenth century to form clubs and societies. Of the many medical societies founded in that century for the advancement of knowledge and the promotion of good fellowship, the Medical Society of London was one of the few that survived. Sir Anthony Bowby, President of the Royal College of Surgeons, in proposing the toast of the Imperial Forces of the Crown, confined himself to the work of the medical services, upon whose efficiency the moral and spirit of the nation and of the forces depend so much in time of war. He told the story of how interference with the French Service de Santé by politicians early in 1917 caused temporary demoralization of the French army and nation after the failure of General Nivelle's offensive. Just before the attack the Minister of War did away with the central authority of the medical service, and the consequent breakdown of the arrangements for disposal, transport, and treatment of the wounded gave the

¹ "Les artères carotides et les hémorragies cataclysmiques de l'amygdalectomie totale." P. Sebileau, *Bull. et Mém. de la Soc. de Chir.*, Paris, January, 1921, 109.

impression throughout France of appalling casualties; false tidings of disaster thus spread up and down the country. In responding to the toast Surgeon Vice-Admiral Sir Robert Hill, Medical Director-General, R.N., paid one more tribute to the services of his civilian colleagues in the Navy during the war, and echoed Sir Anthony Bowlby's hope that, when the time should come for the armed forces to prove themselves again, the medical lessons of the great war would be borne in mind, so that we might start where we left off and not where we began. Major-General M. H. G. Fell, Medical Administrator of the Royal Air Force, also briefly replied. The health of the visitors was proposed in very happy terms by Sir John Bland-Sutton, President of the Royal Society of Medicine, and in responding Lord Justice Atkin, President of the Medico-Legal Society, paid a sympathetic and discerning compliment to the medical profession. Dr. Russell Wells, Vice-Chancellor of the University of London, who also replied, spoke of the value of a university training in producing a good all-round man, as apart from a mere skilled technician, but expressed the view that the three earliest mediaeval universities—Salerno, Bologna, and Paris—all began as technical schools. In briefly proposing the health of the President, Sir D'Arcy Power described Sir William Hale-White as the embodiment of common-sense. A very successful evening ended with a toast to the energetic honorary secretaries, Dr. W. H. Willcox and Mr. H. W. Carson.

CONGRESS OF RADIOLOGY AND PHYSIOTHERAPY.

We may remind our readers that the Congress of Radiology and Physiotherapy, organized by the Electro-Therapeutic Section of the Royal Society of Medicine and the British Association of Radiology and Physiotherapy, will be held in London on April 14th, 15th, and 16th, 1921, under the presidency of Sir Humphry Rolleston, K.C.B. The work of the Congress will be divided into three sections—radiology, electrolgy, and physiotherapy—and at each session papers will be read by representatives of France, Belgium, and England. All communications may be made either in French or English. The subscription for English members is 2 guineas, that for French and Belgian members 40 francs. The Secretary-General is Dr. G. Harrison Orton. Subscriptions should be sent to the honorary treasurer, Dr. J. Metcalfe, at the Royal Society of Medicine, 1, Wimpole Street, W.1.

INTERNATIONAL TUBERCULOSIS CONFERENCE.

As we have already announced, the next Conference of the International Union against Tuberculosis will be held on Tuesday, Wednesday, and Thursday, July 26th, 27th, and 28th, at South Kensington, under the auspices of the National Association for the Prevention of Tuberculosis. The Conference will be open to members of the International Union against Tuberculosis and to delegates from countries within the League of Nations and from the United States. It will be presided over by Sir Robert Philip, M.D., Professor of Tuberculosis in the University of Edinburgh, and the opening address will, it is hoped, be given by M. Léon Bourgeois, the retiring President. A discussion on the modes of diffusion of tuberculosis throughout the races of the world will be opened by Professor Calmette. The other subject proposed for discussion is the rôle of the medical profession in the prevention of tuberculosis.

THE "LANGHAM" TELEPHONE EXCHANGE.

We announced at the end of November that preparations were in hand for the opening of a new telephone exchange in London to relieve the pressure on the existing Mayfair Exchange, and provide additional facilities in the area between Oxford Street and Regent's Park. The area to be served by the new "Langham Exchange" includes Harley Street and Wimpole Street, and therefore contains a large number of lines rented by members of the

medical profession. On Saturday last the new exchange was opened and the circuits concerned were transferred from the Mayfair exchange. We have received from the Controller of the London Telephone Service a list of telephone subscribers affected who, so far as can be ascertained, are members of the medical profession. The list includes some 450 entries; it can be consulted at the Library of the British Medical Association. The new numbers of all those subscribers whose circuits have been transferred from the Mayfair exchange will appear in the next issue of the *London Telephone Directory*, which is due to be published on April 1st next. In the meanwhile, however, special arrangements have been made by the telephone service both to advise callers of the changes and to divert calls to the new exchange.

At the meeting of the Royal Society on May 5th the Croonian Lecture will be delivered by Dr. Henry Head, F.R.S., on "Release of Function in the Nervous System."

Medical Notes in Parliament.

Dangerous Drugs Regulations.

SIR J. D. REES asked the Home Secretary, on March 3rd, why he would not receive a deputation from those primarily interested regarding the draft Regulations under the Dangerous Drugs Act, and whether he was aware of "the general consternation and alarm at the prospect of the regulation of the sale of drugs in the United Kingdom being dictated by gentlemen at Geneva, having no knowledge of the requirements of those needing and selling drugs in the United Kingdom." Mr. Shortt replied that he was perfectly willing to meet representatives of the different bodies interested and discuss the points they might raise on the draft Regulations. The Regulations had nothing to do with any gentlemen at Geneva; the Dangerous Drugs Act, under which they were framed, was passed in order to carry out our obligations under the treaty of Versailles and the International Opium Convention of 1912.

On a question by Major Barnett, on March 8th, whether the Home Secretary would consider the desirability of exempting duly qualified medical practitioners who dispensed their own prescriptions from Regulations which must necessarily prove irksome and oppressive, and involve an intolerable tax on their time, Mr. Shortt said he had received representations from the British Medical Association as to the records which would be required to be kept by medical practitioners who dispensed their own prescriptions, and he had communicated to them certain modifications which he should be prepared to make in the draft Regulations. The matter was still under consideration. Major Barnett further asked whether the draft Regulations provided that any package or bottle containing specified drugs should have plainly marked upon it the name of the drug and the amount it contained; whether the effect of this provision would be to give patients information which in many cases it was desirable they should not possess; and, if so, whether he would exempt from its operation the prescriptions of duly qualified practitioners. Mr. Shortt replied that he had received representations from the British Medical Association on this point, and had informed them that he was willing to agree to the exception suggested.

On a third question by Mr. Kiley as to the position of farmers, Mr. Shortt said that the whole question, including a suggestion as to the possibility of denaturing the drugs supplied for use by farmers, was under consideration, but he was not in a position to make any statement at present.

Proprietary Medicines Bill.

Captain Tndor Rees asked, on March 2nd, whether the attention of the Minister of Health had been called to the advertisement of alleged cures of cancer and other diseases, and whether he would introduce legislation to protect the public from the frauds and deceptions of advertisers. Dr. Addison replied that the Proprietary Medicines Bill, introduced last session, was intended to give effect to the recommendations of the Select Committee, which reported on this question in 1914. The bill was now being revised to meet certain objections of the commercial interests concerned, and he hoped it would be possible to reintroduce it during the present session, but he was unable at present to name any definite date.

Medical Record Cards.

Mr. Forrest asked, on March 2nd, whether the Minister of Health was still receiving any protests from panel doctors as to the work entailed by filling up the new forms of cards; and, seeing that the time so employed diminished the amount of attention that could be given to individual cases, whether he would inquire into the whole matter to see how the system was working. Dr. Addison replied that he could not accept the view that the keeping of records must detract from the time available for giving adequate medical treatment. In the majority of insurance practices the practitioner was responsible for less than one-fourth of the number of insured patients for which, in the view of the doctor's own representatives, an ordinary practitioner could safely assume responsibility. The number of objections from medical men and others concerned in working the system was insignificant. Out of some 150 Panel Committees, representing some 12,000 medical men on the panel, he had received protests from only nine, and those mostly on points of detail, although every effort had been made by certain persons to stir up discontent.

On further question on March 7th by Mr. Myers, Dr. Addison said that the number of complaints he had received about insurance medical records was quite insignificant, consisting of representations from five only out of 10,000 approved societies and branches, none from any of the Insurance Committees, and, as previously stated, nine, mainly on points of detail, out of 150 Panel Committees, representing medical men on the panel. The card was in substitution for two others used since the commencement of the Act, and had been designed mainly to give insured persons the advantages enjoyed by private patients in those practices where doctors kept records, and therefore were enabled to be guided in treating current symptoms by reference to the patient's previous medical history. Mr. Dennis Herbert asked whether it was not the case that one of these later cards was given up because it was practically impossible for doctors to complete it. Dr. Addison said that was quite true, and that was one reason why the revised card was designed. The new card certainly gave much less trouble than the old one. Mr. Herbert said he had studied the card with several doctors, who took a totally different view. Dr. Addison replied that the new card was designed by doctors, mainly by panel doctors, with a view to assisting them in their practice.

Industrial Fatigue Research Board.

Questioned by Captain Coote and Mr. Mills as to the reported decision of the Treasury to withdraw financial support from the Industrial Fatigue Board, Dr. Addison said that the expenditure on the Board was naturally being reviewed with all other public expenditure in the light of the imperative need for economy. The Board itself would be continued, and he thought he could safely promise that sufficient funds would be provided to secure its efficiency.

Security of Tenure for Public Medical Officers.

Sir Philip Magnus asked, on March 2nd, what progress had been made in giving effect to the promise contained in Dr. Addison's letter of May 31st, 1920, in pursuance of a previous promise of the Local Government Board to proceed with an order to give security of tenure to whole-time medical officers. Dr. Addison said he was advised that legislation would be required to afford this security of tenure to existing officers, and the Order which would shortly be issued must therefore be confined to new appointments.

Standardization of Serums, etc.—Sir J. D. Rees asked, on March 7th, whether the Minister of Health was devising a series of expensive measures relating to the control of serums and therapeutic substances, including a controlling authority, a big central laboratory and other machinery in consequence of a report of a recent departmental committee appointed to consider the subject. Dr. Addison said the question clearly referred to a report contained in a leading article in the *Times* of February 25th. There was no truth in the suggestion that he was devising any measures of the kind indicated. From 1909 onwards, suggestions had been made by the General Medical Council and other influential bodies for some method for securing a certain measure of standardization in serums and other potent drugs and substances which could not be tested by ordinary chemical means. In this desire the responsible drug manufacturers appeared to concur, and it should be remembered that some of these substances were made abroad as well as in this country. The Committee reported to him during January of this year, and the chairman (Sir Mackenzie Chalmers), on his own responsibility, suggested a draft bill. When the matter

came before him (Dr. Addison) in January, he took the view that action on the lines indicated by the proposed bill was not practicable. So far as he had examined the subject the Committee appeared to contemplate that the Medical Research Council, which already had laboratory equipment, should supervise the carrying out of whatever test proved to be required. No action whatever had been taken upon the report, nor any recommendation made to his colleagues. The intentions attributed to him were entirely fanciful.

Mortality from Tuberculosis.—In reply to Lieut.-Colonel Raw, Dr. Addison said, on March 3rd, that although the conditions of active service no doubt increased the mortality from tuberculosis in weakly men, and in those already suffering from tuberculosis, he was advised that there was no evidence to show that there had been any increase in mortality from this disease among men who were healthy upon entering on naval or military service. The latest statistics indicated that there was in 1919 a very large decrease in the number of deaths from tuberculosis in England and Wales, including both pulmonary and non-pulmonary forms; the figures for 1919 being 46,312, as compared with 58,073 in 1918, and 55,954 in 1917. The figures for 1920, so far as they were at present available, indicated another decrease.

Venereal Disease Report.—Lieut.-Colonel Fremantle asked, on March 2nd, whether the attention of the Minister of Health had been called to the report of the Special Committee on Venereal Disease, recently published, and to its recognition of the value of immediate self-disinfection; and what steps were proposed to be taken by his department in the matter. Dr. Addison replied that the subject was now under consideration. All the relevant documents and evidence, including the report mentioned, would be considered.

Disability Pensions.—Colonel Gibbs, on behalf of Mr. Macpherson, stated on March 3rd that the number of cases in which a pension had been refused to an ex-service man on the ground that the disability on which he claimed was not due to service, was 25,700. In the case of widows the records of the Ministry did not show refusals before April 1st, 1920; the number of rejections since that date was 6,900. In all cases of refusals, whether of men or of widows, there was a right of appeal. Colonel Gibbs added that a man had a right of appeal to a medical board on the question of assessment, and to an independent tribunal on the question of attributability. On further questions Colonel Gibbs stated that the appeal tribunals had heard and decided 1,978 appeals lodged by widows against decisions by the Ministry that the disease from which the husband died was not contracted in, nor aggravated by, his service. Of those appeals 523 were allowed and 1,253 rejected. The decisions of the tribunals were final. These appeal bodies consisted each of one doctor, one lawyer, and an ex-service man. Major Glyn asked, on March 3rd, whether the Minister of Pensions was aware that in the event of a dependant entering a rate-aided institution—for instance, a lunatic asylum—the pension to which such an individual was entitled was suspended during the period of detention, and whether the Minister would consider the desirability of paying it to the local authorities for the relief of the rates, until such time as the man emerged from the institution. Colonel Gibbs said the matter was under consideration.

Housing and Tuberculosis Bills.—On inquiry by Mr. Ormsby Gore, on March 3rd, Dr. Addison announced that he proposed to introduce the Housing Bill and the Tuberculosis Bill before Whitehall.

Food Values.—Captain Elliot asked, on February 25th, if the Minister of Health would consider whether information regarding nutritive and economical foods could be circulated to local authorities, education authorities, and the press, in view of the present distress and the great amount of manufactured and semi-manufactured food consumed by the people of this country. Dr. Addison replied he was considering whether it would be practicable to issue a pamphlet containing information on the lines suggested. It was difficult to make any general statements with regard to the values of food which were not liable to be misconstrued. He was having certain researches conducted on the subject in connexion with the Medical Research Council.

Maternity and Child Welfare Centres.—In answer to Sir Keith Fraser, on March 2nd, Dr. Addison said that according to the latest available information 43 persons (of whom 25 were men) were appointed during 1920, specifically as medical officers of maternity and child welfare centres, the annual rate of remuneration not exceeding £11s. 6d. per session, and amounting in the aggregate to about 43,660 per annum. In addition 36 persons (of whom 10 were men), were appointed by local authorities during this period, as whole- or part-time medical officers for maternity and child welfare work generally, at salaries varying from £150 to £750 per annum. These duties included in every case more or less direct supervision of the work of centres, but it was not possible to make any apportionment of the salaries for that purpose, or to estimate, even approximately, what proportion of annual cost of welfare work was attributable to this branch of the service. Milk and, in special circumstances, other food might be provided at less than cost for expectant and nursing mothers, and for children under five years of age, when such provision was certified by the medical officer of health for the centre or by the medical officer to be necessary and where the case was necessitous.

England and Wales.

THE LONDON COUNTY COUNCIL AND MEDICAL WOMEN.
The London County Council requires as a general rule the women in its service to resign their appointments on marriage, but the operation of this standing order was waived for a time in the case of the women doctors, pending a report on the subject; the Council employs 31 medical women, of whom 5 are married. The General Purposes Committee reported to the Council on March 1st that the policy to be adopted in connexion with the employment of married medical women was very difficult to formulate. The Public Health Committee's view was that it was undesirable that medical women should leave the Council's service on marriage, and the medical officer of health also considered that married women doctors were able to bring specially valuable experience to their work. On the other hand, absence from duty owing to domestic reasons may involve the employment of temporary doctors, with, probably, some loss to the efficiency of the Council's service. During the past five years there have been two cases of absence of married women doctors owing to confinement. The Council, after receiving the report, decided to continue the employment of married medical women for a further period of three years from October next, when the period covered by the former resolution comes to an end. It was stated that difficulty was experienced at present in obtaining medical women of suitable qualifications in view of the general shortage of medical practitioners resulting from the war. Since the end of the war there has been a large increase in the number of medical students, women as well as men, but such students will not be ready for qualification until 1923 onwards.

PRESENTATIONS TO DR. ADAM FULTON.

On March 2nd Dr. Adam Fulton, late of Basford, Nottingham, was the recipient of a presentation from his fellow practitioners in Nottingham and Notts, as an appreciation of his untiring devotion to the interests of his professional brethren, on the occasion of his leaving the district to become a divisional medical officer under the Ministry of Health. On behalf of the local profession, Dr. C. J. Palmer, chairman of the Nottingham Division of the British Medical Association, and Dr. O. Isard, chairman of the Nottingham Panel Committee, congratulated Dr. Fulton on his appointment and wished him the best of luck. The presentation of a high power binocular Leitz microscope was then made by Dr. J. F. Blurton, president of the Nottingham Medico-Chirurgical Society. The speakers reminded the meeting that no man had done more to further the interests of the medical profession in the district than Dr. Fulton ever since he came to practise among them, especially in the direction of improving the conditions of contract practice. Dr. Fulton had been chairman of the local Medico-Chirurgical Society, and was largely instrumental in securing the purchase of its headquarters in St. James's Street. He had been chairman of the Nottingham Division and also of the Midland Branch of the British Medical Association, had represented the Division at the Representative Meetings, and for many years had been a very active member of the Council of the Association. He was also the first chairman of the Nottingham Panel Committee, and his sound judgement and knowledge of the Insurance Act proved of the greatest help to his fellow practitioners. During the war Dr. Fulton was a member of the Central Medical War Committee, and he cheerfully undertook the duties of the secretary of the Nottingham Division of the British Medical Association during the latter's absence on war service. He was a member of the City Council of Nottingham and vice-chairman of the Health Committee of the Council, and the Minister of Health appointed him a member of the Consultative Council of the Ministry. He had now left Nottingham, having accepted a post under the Ministry of Health, with his headquarters at Southport. Dr. Fulton, in returning thanks after the presentation, recalled some of the more strenuous fights of bygone days, and traced the gradual growth of the power and organization of the British Medical Association. Dr. Fulton was also presented on the same day with a

handsome silver salver, suitably inscribed, by the Mayor of Nottingham on behalf of the City Council, in recognition of the valuable services he had rendered to the city as a councillor. The Mayor expressed the debt of gratitude the city owed to Dr. Fulton, not only on account of the benefit they had had from his medical knowledge, but also on account of his unusual business abilities. In the evening another presentation was made to Dr. and Mrs. Fulton as a token of the regard in which they are held by the residents of Basford. Alderman Pendleton referred to the happy relations which had existed for twenty-seven years between Dr. Fulton and the people of Basford, and on their behalf presented a massive oak bookcase and a Coalport china tea-service.

THE WARNEFORD HOSPITAL.

The annual Court of Governors of the Warneford General Hospital was held in the Town Hall, Leamington, on March 2nd, Dr. T. W. Thursfield taking the chair in the absence of Lord Algernon Percy. The annual report showed that 160 beds were available in the hospital, and the ordinary income had amounted in 1920 to £14,431, as against £12,826 in 1919; but the expenditure had exceeded income by £2,414, leaving a deficit balance of £2,294 to carry forward. A Ladies' Village Association had been started during the year in order to keep the villages of the area in touch with the requirements of the hospital. Dr. Thursfield said that it had been intended to carry out necessary improvements by building a new out-patient department and new nurses' quarters; but owing to the increased expense only the former could be done, and that through the liberality of the trustees, a timely legacy, and a gift from the Red Cross Society.

Scotland.

EDINBURGH STUDENTS IN PARIS.

Owing to the disproportion between the population of Edinburgh and the number of medical students in the city it is difficult to find a sufficient number of obstetric cases to comply with the regulations. A few months ago the Deau of the Medical Faculty suggested that an arrangement might possibly be made by which some of the students, men and women, should attend the requisite number of cases in Paris. Negotiations were opened up by Sir Halliday Croom, professor of midwifery in the university, and Dr. J. W. Ballantyne, lecturer on midwifery to women students in Edinburgh, with Professor Bar, the director of the Tarnier Hospital in Paris, who showed the utmost goodwill. All arrangements having been completed a party of thirty-five, consisting of fifteen men students and twenty women, left Edinburgh on March 4th, and on their arrival in Paris were met by some members of the Students' Association, who took the men of the party across Paris and entertained them at dinner. The ladies appear to have slipped away unnoticed.

THE ROYAL EDINBURGH MENTAL HOSPITAL.

The Royal Edinburgh Mental Hospital, known for so many years as Morningside Asylum, consists of two departments, the West House and Craig House, the latter erected five-and-twenty years ago for private patients paying the higher rates of board. The annual reports of the late Sir Thomas Clouston were never dull reading, and Dr. G. M. Robertson, his successor as physician-superintendent, has the same gift of interesting the public in the work of the institution. His report for 1920, the hundred and eighth annual report, shows that the number of patients in the West House was at the beginning of the year 731, and at the end 756, the corresponding numbers for Craig House being 262 and 274. The patients admitted during the year numbered 523 (West House 397, Craig House 126). This is the largest number admitted in any year since 1900, and more than half of the average number of patients resident, which was 1,001. Sir Thomas Clouston attributed the large number of admissions in 1900 to the excessive use of alcohol during a time of brisk trade and high wages. Dr. Robertson points out that the same explanation cannot apply to 1920, when the percentage of cases in which alcoholic excess was believed to

have been the cause was only 6.5 of the total admissions as compared with 23.5 in 1900. He gives the following table:

Percentage of Admissions Suffering from Insanity in which Alcoholic Excess was believed to have been the Exciting Cause during the Seven Years before and after the Outbreak of War.

	Male.	Female.		Male.	Female.
1907	13.6	9.2	1914	16.0	4.6
1908	15.0	7.5	1915	10.0	2.5
1909	16.4	9.8	1916	10.8	4.1
1910	13.9	11.2	1917	15.5	3.0
1911	28.9	9.7	1918	10.5	2.4
1912	14.0	8.6	1919	12.6	1.2
1913	12.5	11.5	1920	13.3	1.0

Seven-Year Averages.

	Male.	Female.
1900-6	30.4	14.4
1907-13	16.3	9.6
1914-20	12.6	2.6

Dr. Robertson does not ask the public to be satisfied with this improvement, but expresses the hope that the Legislature may devise some measure which at the present stage will create less bitterness and resentment in a large section of the people than total prohibition. The fact that the number of admissions was so high implies, as is pointed out, that the majority were in the early and acute stage of their illness, and therefore needed special medical attention and careful nursing. The institution thus partakes to a great extent of the nature of a reception hospital, and this fact entails the employment of a larger staff and a large expenditure. Constant removals were necessary to provide accommodation for so many new patients suffering from an illness like insanity, which, even when a good recovery takes place, usually lasts months. During the year 139 patients were discharged recovered and 119 so far recovered that they could be handed over to the care of their friends; 76 were transferred to other institutions, and 152 died. These features of the medical statistics are due to the fact that the institution is still carrying on war work, and will continue to do so until the Bangour Village Asylum is reopened for the admission of patients from Edinburgh. It will be remembered that Dr. Robertson is himself professor of psychiatry in the University of Edinburgh, and he notes that Dr. Yellowlees, senior assistant physician, and his colleague, Dr. W. McAlister, have now been appointed university assistants; they conduct tutorial classes, the former in psycho-pathology and psycho-therapy, and the latter in mental defects and mental tests. The requirements for the diploma in psychiatry have been revised, and Dr. James Drever, Coombe lecturer in psychiatry in the university, has established an optional course of lectures in psychiatry for medical students. Further reference to the report will be found at page 394.

ABERDEEN UNIVERSITY WAR RECORD.

The University of Aberdeen is preparing a record of the services of its members during the great war, and memorials to those of them who fell in action or went down with their ships, or died of wounds or disease. The record contains about 3,000 names of graduates, alumni, students and members of the staffs, with particulars of the service of each and of the distinctions he gained. It is to be preceded by brief biographies, with portraits of the 337 who laid down their lives for their country and its cause. A large part of the volume has gone to the press, and the rest is rapidly nearing completion. The memorials which have been planned consist of a stained glass window in the ante-chapel of the University Chapel, at King's College, with oak panels on the walls bearing the names of the 337; of another window in the chancel, and of a memorial porch in Marischal College. The total cost of these memorials has been estimated at between £9,000 and £10,000. So far £4,700 has been subscribed, but further subscriptions are necessary, and may be sent to the Principal or to the Honorary Treasurer, D. M. M. Milligin, Esq., 12, Dee Street, Aberdeen.

DUNDEE ROYAL INFIRMARY.

Mr. Richard Charles Alexander, M.A., M.B., F.R.C.S. Ed., has been appointed visiting surgeon to the Dundee Royal Infirmary in succession to the late Mr. W. L. Robertson. Mr. Alexander is at present Assistant in the Surgical Department of the University of Edinburgh, Tutor in Clinical Surgery at the Edinburgh Royal Infirmary, and Assistant Surgeon to the Chalmers Hospital, Edinburgh. He served in the R.A.M.C. during the war, attaining the rank of major, and was mentioned in despatches.

Correspondence.

SURGERY OF BREAST CANCER.

STR.—Mr. Sampson Handley's lecture and the correspondence it has elicited are of great interest to surgeons. For the past ten years I have made it the rule, unless there was some special contra-indication, to add the supra-clavicular region to my operations for cancer of the breast in all cases in which the primary growth was situated in the upper half of the breast, and in all cases, wherever the primary growth was situated, provided that palpable secondary glands were present in the axilla. My reasons for this extension of the operation have been two:

1. That supraclavicular recurrence appeared in a certain proportion of cases in which there was no clinical evidence of extension elsewhere.

2. On general grounds it appeared to be sound, in cases where the axillary glands showed evidence of enlargement, to remove the next group of glands *not* enlarged: for cancer cells are certainly present in glands long before the latter are palpable. Mr. Parry's microscopical evidence of the condition of the supraclavicular region is proof of this, if proof were wanting of so obvious a fact. Indeed, the rule to remove the next group of glands *not* enlarged is desirable wherever practicable in dealing with cancer. The clearing out of the supraclavicular region adds little to the operation, and does not appreciably increase the risk.

There is no time for dealing radically with cancer so favourable as the first time, and to anticipate supra-clavicular extension, even at a slightly increased risk, is far preferable to attacking it when present. The extension of the operation to the anterior mediastinum is not comparable in any way to the supraclavicular extension, as one is a simple business and the other is not.

It is to anticipate recurrence in the anterior mediastinum that I should be inclined in the future to follow Mr. Handley's advice to use buried radium in the upper inter-costal spaces. In endeavouring to deal radically with cancer, every means at our disposal which science or practice suggests should be roped in. The time limit is a delusion, as every surgeon who follows up his cases must admit. It was first fixed at three years and subsequently extended to five. Some cases are undoubtedly cured but there is no time limit.

Apart from the cures, the great gain that is evident from our extended operations and auxiliary means of combating this disease is that the period of recurrence is considerably extended as compared with twenty years ago. It is commonly five, six, or seven years, where it used to be one, two, or three; and though five, six, or seven years may seem of small account in the first half of life, in the last three decades they are appraised at their true value.—I am, etc.,

CHARLES P. CHILDE, B.A., F.R.C.S.

Portsmouth, March 7th.

X-RAY RADIATION AND CANCER.

STR.—In the literature devoted to *x*-irradiation of malignant diseases, the statement keeps constantly recurring that weak doses stimulate malignant growth, "thereby hastening the very end we are doing our best to avert."

During the past fifteen years I have treated very many cases of all sorts of malignant growths, and my experience does not bear this out. I have always found that the treatment, even when it did not cure, generally retarded the growth. The most interesting paper by Drs. Sydney Russ, Helen Chambers, Gladys M. Scott, and J. C. Mottram, on "Experimental Studies with Small Doses of X Rays" (*Lancet*, April 26th, 1919) would also seem to support my view. This paper ought to be read by every

surgeon, for it is full of suggestion, and should point out to them the importance of pre-operative treatment, especially of mammary carcinoma, which is so largely neglected by English surgeons as compared with American surgeons.

I have seen it too often to have any doubt on the subject, that operation for mammary carcinoma, of even the most favourable type and done in the most thorough manner by the most capable surgeons, is followed in a large percentage of cases by rapid dissemination, which I am sure could have been averted by pre-operative treatment; whether by direct action on the carcinomatous cells, by its constrictive action on the lymphatics, or, as suggested in the paper above referred to, by its action on the blood, matters not.

Returning again to the subject of small doses stimulating malignant growth, I am anxious to find out whether or not this is one of the "myths" that are constantly copied from one writer by another and so perpetuated in medical literature, and I should therefore be exceedingly grateful to any one who can give me any evidence, experimental or otherwise, to prove the statement.—I am, etc.,

Bradford, March 1st.

WILLIAM MITCHELL.

THE SEARCH FOR A SPECIFIC TREATMENT OF TUBERCULOSIS.

SIR,—In view of the article under the above heading in the BRITISH MEDICAL JOURNAL, February 26th, 1921, which appears to be, so far as I know, the first indication of the general nature of Mr. Henry Spahlinger's treatment, may I be allowed to point out that investigations on parallel lines, as it seems to me, have not been altogether neglected in this country?

It is stated that Mr. Spahlinger's injections consist of "a combination of tuberculous antigens and of ferments" combined with "auxiliary treatment composed of ferments associated with lipoids."

During the past few years my attention has been concerned with lipase,¹ the lipolytic or fat-splitting ferment, and from experimental work carried out in the physiological and bacteriological laboratories, King's College, I² have concluded that in induced tissue lipolysis an explanation is afforded in part of natural and therapeutic immunization—that is to say, the main idea or principle underlying treatment in bacterial disease is, as I have suggested, the production of the lipolytic or fat-splitting ferment in the tissues, which in tuberculosis acts on the fats and lipoids of the tubercle bacillus, and is injurious to it. As I have shown, there are a number of substances which have the power of increasing or stimulating such lipolytic or fat-splitting action *in vitro* and *in vivo*. This property is shared by serum proteins, various tissue extracts, sodium oleate and inorganic salts, such as the phosphates and salts of calcium.

The same principle in part underlies treatment by vaccines and tuberculins, in which activators or co-enzymes of the fat-splitting ferment are present in varying degree. The tubercle bacillus itself is known to contain proteins, lipoids, fatty acids, phosphates and calcium, in addition to a large amount of fats and waxes. I have preferred to adopt the nomenclature of activators or co-enzymes rather than "antigens," because the former more correctly indicate the part played in the production of the lipolytic ferment. But to which of such activators or co-enzymes a therapeutic effect may be due is uncertain.

In drawing attention to this interpretation of the action of vaccines and tuberculins, I³ suggested at the same time that "the products of ferment and bacterial digestion" might prove more serviceable than vaccines. In this connexion the serum of patients recovered from tuberculosis markedly accelerates or activates the fat-splitting action, compared with a decreased power in the acute stages. The former contains, as I concluded, the products of digested or partially digested tubercle bacilli, the result of the lipolytic or bactericidal action. Such products—namely, fatty acids or particular soaps derived or prepared from the action of the lipolytic ferment on the fats and lipoids of the tubercle bacilli—may not only be protective or

act as stimulants to lipolytic activity, but the initial action of the ferment may liberate other contained activators. The presence of proteins or lipo-proteins in the tubercle bacillus does not exclude the products of proteolytic action secondarily, as such induced tissue ferments cannot, in view of the fatty capsule of the bacillus, be expected to act primarily. Similar products conceivably result from the growth of the living bacteria in the tissues or in nutrient media, or as a result of autolysis.—I am, etc.,

J. A. SHAW-MACKENZIE, M.D. Lond.

London, March 1st.

THE RETARDED CINEMA AND CARDIAC ACTION.

SIR,—Referring to the interesting demonstration of the retarded cinema which Dr. Monod-Walter gave last week at the Royal Society of Medicine, your annotation (March 5th, p. 359) states that his second film, that of the isolated mammalian heart, showed "what most British students of to-day have seen in the laboratory." This is so as regards the film showing the normal rate of cardiac movement, but not, I think, as to what the retarded film showed. Someone had suggested that the films showed auricular fibrillation, possibly because the auricles exhibited little activity. The action of the heart was, however, regular, which is scarcely compatible with usual conceptions of auricular fibrillation. The auricles were, in fact, distended by the method used for maintaining the circulation.

The point, however, of most interest shown by the retarded cinema was a condition the existence of which is disputed by many, and which the film of the normal rate did not show—namely, a distinct hemisystolic action of the ventricles. Noting this at the first demonstration, I also attended the second, and was confirmed in my impression that contraction of the right ventricle preceded that of the left in the retarded film. A film, however, still more retarded would show the condition better. Should it be possible to photograph movements of the heart by the retarded cinema through the fluorescent screen the method might be of clinical interest, if not service. For, although in dissociated auriculo-ventricular action the greater rate of auricular over ventricular movement may be seen by the naked eye through the screen, a retarded picture would show this condition much more easily. This state, however, may be easily determined by other methods already in use. But the existence of ventricular hemisystole, in which from clinical observation I personally believe, would be more generally acknowledged were the retarded cinema found to show this state indubitably, as I think, with a little increased retardation, it would do. Nor would this be merely a matter of curiosity, for it would help to explain certain physical signs detected by auscultation.—I am, etc.,

London, March 7th.

ALEXANDER BLACKHALL-MORISON.

THE CURE OF HAEMORRHOIDS WITHOUT OPERATION.

SIR,—The article by Dr. Lyth and the letters which it has called forth appear to me to typify the attitude very often adopted by medical men in advising patients.

The number of conditions where the practitioner is justified in telling a patient that he *must* be operated on is relatively small; on the other hand, there is a multitude of disabilities where operation alone offers anything like a certainty of cure. I mean, of course, such diseases, to name but a few, as piles, chronic appendicitis, pyloric ulcer, gall stones, hernia, varix, prolapsus uteri, etc.

Surely the only course which an entirely unprejudiced doctor is justified in taking in such a case is to state the alternatives as clearly and fairly as possible to the patient and leave him to make the choice, instead of practically insisting upon his adopting whichever alternative appeals to the practitioner's predilections.

In a condition such as that described by Dr. Lyth I should be inclined to say to the patient: "You are suffering from engorged piles; the engorgement can be got rid of by medicine and local applications, after which you may, by carefully regulating your life, go along fairly comfortably, perhaps for many years; on the other hand, if you wish to be able to lead an entirely normal life and to be free from rectal discomfort, the only certain remedy I know is the removal of the diseased veins by surgical means."

¹ Proc. Roy. Soc. Med. (Therap. and Pharm. Section), V, 1912, p. 152; Internat. Congress Med., London (Therap. Sect.), 1913; Journal of Physiology, xlix, 1915, p. 216.

² Lancet, 1919, ii, p. 825; Med. Press and Circular, 1920, ii, pp. 122 and 460.

³ Med. Press and Circular, 1915, ii, p. 190.

Many patients will decide to lead a modified life rather than submit to operation, but many others (and we may surely rejoice that it is so) will act according to the Stevensonian axiom that "the love of living is stronger in an Alpine climber roping over a peril, or a hunter riding merrily at a stiff fence, than in a creature who lives upon a diet and walks a measured distance in the interests of his constitution," and will wish for curative rather than palliative treatment.

I am convinced that an enormous amount of defective health is the result of failure on the part of medical men and women to point out clearly the pros and cons of surgical treatment; that this is so is illustrated by the frequency with which patients whose lives have been made fuller and more comfortable by operation tell me that they would have had the operation done earlier had not their doctor definitely dissuaded them.—I am, etc.,

Bradford, March 6th.

JAMES PHILLIPS.

SIR,—I had anticipated that critics of the method which I advocated would not be wanting. I had, however, expected them to be found in the ranks of surgery rather than of medicine.

Dr. Copeman's letter amounts to a direct negative, unsupported by either theory or practice, which does not form a basis for discussion. He is welcome to his little joke; but if he reads my article again, he will see that I quite recognize that certain haemorrhoids cannot be replaced within the sphincter ani, and indeed, that it is preferable that no undue attempts should be made to treat them in this way. His sorrow and his hilarity will therefore be wasted in my case.

Dr. Morley's criticisms, on the other hand, strike at the basis of the treatment which I adopt, and if they were justified no lasting results could be obtained in this way. I do obtain such results, so I am constrained to examine his criticisms for the flaws which they must contain.

There are two main questions at issue: (1) Whether internal haemorrhoids can become external haemorrhoids; and (2) whether internal haemorrhoids cause severe symptoms without prolapsing.

In regard to the first question, which Dr. Morley answers with an emphatic negative, I am afraid he is assuming that the condition in which he finds the parts is that in which they have been more or less throughout the course of the disease, and in which they remain throughout the changing conditions of everyday life. I am aware that his view, while not definitely stated, is that tacitly assumed by most authors. Yet this is by no means entirely so; and although I am in the habit of preferring my own observation, when practicable, to that of others, I find that Walsham and Spencer (*Theory and Practice of Surgery*) describe three kinds of piles—the internal, covered with mucous membrane; the external, covered with skin; and others, "in many instances covered in part with skin and in part with mucous membrane," which they refer to as "mixed piles." This condition, I take it, is produced when "internal piles" have been outside long enough for the process of conversion to "external piles" to be taking place. Keen describes a fourth variety as "false piles," the tags of skin into which, in my view, the piles when cured become converted. We have thus the complete sequence I described. Moreover, all authorities agree in describing the etiology of internal and external piles as identical, and all agree that internal piles may become permanently prolapsed and yet may be spontaneously cured in that position. One cannot help wondering what an "internal pile" outside the anus, still covered with mucous membrane and yet cured, looks and feels like.

From the point of view of clinical experience my own observation leaves me not the slightest doubt that, as I stated in my article, the distinction between internal and external haemorrhoids is purely artificial. It may be that Dr. Morley has not been under the necessity of watching the course of an individual pile for several years, day in and day out. I have had that experience, and I assert that without a doubt it began by prolapsing occasionally, and ended as a tag of skin. From correspondence which I have had with other practitioners I know that I am not alone in this view; but even if I were, "seeing is believing." That there is nothing histologically unique in mucous membrane giving place

to skin when exposed to conditions outside the body will surely be admitted—for example, the glans penis after circumcision.

This assumption that the relation of the parts during examination is necessarily or even probably that existing during the whole twenty-four hours is evidenced even more markedly in Dr. Morley's second contention: that internal piles cause severe symptoms without prolapsing. If he had read my article a little more carefully he would have noticed that I stated that "so long as it is inside and remains inside—even during defaecation—it does little harm." He assumes, because he finds piles inside the anus causing haemorrhage, etc., that these symptoms occur while the piles are inside. In the same way, until comparatively recently the stomach was regarded as a "stomach-shaped" organ because its *post-mortem* appearance gives this definite shape. It is only since x-ray examinations with bismuth meals have shown that it is rather to be regarded as a muscular tube that a true conception of its condition in the living body, under the changing demands of digestion, has been arrived at. Likewise, Dr. Morley regards the anus as a canal having a certain lining; he does not appreciate the fact that this lining is normally protruded to a marked degree during defaecation. Yet a very little observation, of animals no less than of human beings, should have made him realize this. The erectile tissue remaining as a vestige of reptilian life lends itself to this, no less than the musculature and heavy pressure from above. Keen states, in regard to internal haemorrhoids, that "the physician will secure a demonstration of them by having the patient strain in the squatting posture after enema." Furthermore, how can a pile bleed externally (excepting the negligible quantity which is passed along with the motion) unless it is prolapsed? In point of fact the most severe haemorrhages take place after the motion, while the patient is still at stool, with the haemorrhoids prolapsed, the blood often squirting in all directions as from a cut artery. Yet after time has been allowed for their replacement—perhaps soon and automatically—such a patient may be examined without any prolapse being found or stated to have occurred. Such piles Dr. Morley would regard as having never prolapsed. Yet if the bleeding were to take place inside the anus and above the sphincter the experience would be that a quantity of blood would accumulate to be passed in front of the next motion; it would be dark and clotted. In point of fact the bleed comes after the motion, and is bright red and fluid. It is while such haemorrhoids are thus temporarily prolapsed, immediately after a motion, that it is possible to apply the treatment which I have advocated; and in my view, unless there is at least temporary prolapse, there are no serious symptoms.

So much for the pathology. In regard to treatment, Dr. Morley is guilty of distortion in assuming that I suggest that a patient who has undergone this treatment must afterwards wear a pad and powder the piles frequently. I said nothing of the kind. I advised that he should have a pad and calamine powder available. In point of fact, beyond the nocturnal defaecation, which I would in any case advise even after operation, I have not found that any further treatment, such as the application of the powder, is necessary, unless undue constipation or an attack of diarrhoea has been experienced. To point a comparison of this state of affairs with that after operation, I am at this time instituting treatment in the case of a lady who had her haemorrhoids removed by operation some five years ago.

I cannot discuss from experience Dr. Morley's treatment by injection; but I notice that even this treatment is not instantaneous nor very simple, as he says that the injections must be repeated at weekly intervals (for an indefinite period, which does not entitle him to the scorn with which he regards the six weeks I have specified as an average space of time. Moreover, I find that Warbasse (*Surgical Treatment*) regards injection with phenol as dangerous. He says, "Pyemia and hepatic abscess have followed this treatment," and that it is "justified only when the patient understands the risk, when an anaesthetic cannot be administered, and when a surgeon capable of performing a safer operation cannot be had." In the face of such a warning I prefer to go on curing my patients in my own way, which is safe, if not heroic.—I am, etc.,

York, March 5th.

J. C. LYTH, M.B., B.S.

PUERPERAL INFECTION.

SIR,—There have been many articles of late on this subject, but it seems to me that many of the writers do not fully realize the conditions under which the average practitioner has to work. The question of perfect asepsis is after all very largely one of expense. It is suggested that we should arrive at our cases armed with drums of sterile gowns, dressings, towels, gloves, and other impedimenta, as for a surgical operation in a fully equipped hospital. To use these properly we should require at least two capable trained nurses, and for most cases a qualified assistant. We should also have a room to work in suitable to accommodate all the impedimenta we brought with us.

The other side of the picture is provided by our actual experiences. Our equipment has to be of such dimensions as can be carried on a bicycle or motor cycle or in our hands; our only assistant is usually an untrained monthly nurse or a relative of the patient; there is frequently a lamentable deficiency of the ordinary articles of utility. The patient has almost invariably a fully loaded rectum, which empties itself during the passage of the head over the perineum, infecting everything within a radius of a yard or so. The doctor has to apply the forceps or do other operations and give the anaesthetic at the same time, because the extent of the money available is in the neighbourhood of £2 (to include attendance for ten days). To carry out the precautions necessary to ensure absolute asepsis—which most of us fortunately desire—would involve an expenditure of at least £10 to £15, and probably more.

Under present conditions the most careful practitioner cannot help getting a certain, though fortunately small, proportion of cases which get some degree of infection. Perhaps in the remote future confinements will be made compulsory in properly equipped State lying-in hospitals where expense will be no object, but until then we shall not reach our Mecca of perfection.—I am, etc.,

H. W. OGLE-SKAN, M.R.C.S., L.R.C.P.

Hendon, N.W., March 6th.

RISKS AFTER OPERATIONS ON TONSILS AND ADENOIDS IN OUTDOOR CLINICS.

SIR,—The recent correspondence on this subject has described nothing that was not known to us all, with the possible exception of one or two favoured individuals. We should all like these operations done under better conditions. Neither the general public, nor the subscribers, nor hospital boards of management are ignorant of the facts. The correspondence leads nowhere. Dr. Andrew Little says that his worst cases have been private cases carefully attended to in good nursing homes. Exactly so. It would be quite easy, on the other hand, to demonstrate surprisingly good results from the present system.

The only point that appears to have been really established is that an occasional case will give trouble or go wrong whatever the conditions may be. Within my experience there has been vast improvement, speaking generally, in the circumstances under which these operations are done. This improvement can continue, and no doubt will continue. Most people know that counsels of perfection are out of the question at present in most places.—I am, etc.,

London, W., March 2nd.

T. JEFFERSON FAULDER.

FATAL POISONING FROM ACID FUMES.

SIR.—I was greatly interested in Dr. T. Gillman Moorhead's communication in your issue of January 15th, under the heading of "Fatal poisoning from the inhalation of acid fumes in a laboratory." It is apparent from the very wording of this heading that Dr. Moorhead was unable to arrive at an exact diagnosis.

To my mind the course of events becomes very clear by a process of analysis and exclusion. In the first place, of the three compounds with which the unfortunate student was working, one only could give rise to fumes of such toxicity by the action of sulphuric acid—namely, the stibnite. If this were an impure sample, if there were any metal present, such as iron or zinc, forming hydrogen with this acid, or if such a metal had been wilfully introduced in the course of the experiment, it is highly probable that stibine, or antimoniated hydrogen, was evolved. This gas is intensely poisonous, and practically odourless.

On looking through Dr. Moorhead's notes of the case we find two separate sets of symptoms: the earlier consistent with direct irritation of the respiratory tract by the inhalation of the acid fumes—trivial in itself and of almost daily occurrence in a big chemical laboratory—and the later due to absorption of some poison into the system. And these later symptoms—namely, furred tongue, rapid feeble pulse, weakness and loss of weight, diarrhoea, albuminuria, icterus and hepatic enlargement (due, doubtless, to fatty degeneration)—are a perfect picture of antimony poisoning.

Was a *post-mortem* examination made? The presence of a sufficient quantity of antimony in the body to carry out Marsh's test would almost certainly have clinched the diagnosis. As regards prognosis, the case was probably hopeless from the outset owing to the difficulty of eliminating antimony absorbed in such a way.

As regards its importance to laboratory workers, I think the lesson to be learnt is that the fume chambers in this particular laboratory are not effectively ventilated for work with lethal gases.—I am, etc.,

WILLIAM CORBET, M.B.

Point Fortin, Trinidad, Feb. 10th.

PREVENTION OF VENEREAL DISEASE.

SIR,—I think some of the objections to the issue of prophylactics to the civil population are, briefly, as follows:

The issue of such preventives tends to undermine that reasonable and natural self-control which is the truest safeguard against disease. Self-disinfection increases the number of men who expose themselves to infection, is admittedly unreliable, and will eventually increase disease. It is useless and inconsistent to instruct the young on matters of sex, including the advantages of continence, and at the same time to countenance the issue of prophylactics. Early marriages reduce the prevalence of venereal disease. The encouragement of illicit intercourse means fewer marriages and less family life.

The issue of prophylactics is unscientific. It does not attack the real causes of the trouble. Such a policy tends to direct attention away from those social, economic, and hygienic reforms which have a real and lasting influence in reducing venereal disease.—I am, etc.,

Libodi, South Africa,
Feb. 6th.

L. C. ROWAN-ROBINSON, M.B.

Obituary.

SIR FELIX SEMON, K.C.V.O., M.D., F.R.C.P. LOND.,
Honorary Consulting Laryngologist, National Hospital for Paralysis;
late Physician Extraordinary to H.M. King Edward VII.

It is with deep regret that we record the death of Sir Felix Semon on March 1st at his residence, Rignalls, Great Missenden, at the age of 72 years.

Felix Semon was born at Danzig on December 8th, 1849, the son of a stockbroker, and began his medical studies in 1869 at Heidelberg. He served in the Franco-Prussian war of 1870 as a volunteer with the 2nd Uhlans of the Prussian Guard. After the war he returned to Berlin, and graduated M.D. in 1873. He then went to Vienna and Paris for post-graduate work, devoting his attention especially to diseases of the throat, a department of medicine then in its infancy, but destined to far-reaching developments, to which Semon in his lifetime contributed so largely.

Semon was appointed a clinical assistant at the Throat Hospital, Golden Square, London, in 1875, where his exceptional talents and capacity for scientific research were quickly recognized and led him to decide to settle in London. In 1876 Semon was admitted a Member of the Royal College of Physicians of London, and in 1885 became a Fellow of that College. He was elected in 1877 to the honorary staff of the Golden Square Hospital, and in 1882 physician in charge of the Throat Department of St. Thomas's Hospital, where he founded the special clinic to which his rapidly increasing reputation as a sound and reliable teacher and practitioner, attracted a great many students and practitioners. In 1888 he was appointed laryngologist to the National Hospital for the Paralysis and Epileptic, where he had opportunities for the special investigation of the neurological problems in laryngeal paralysis and other throat affections, to the elucidation of

which he had already devoted himself with signal success and, with his friend the late Sir Victor Horsley, entered on clinical and experimental researches which made for British laryngology a world-wide reputation.

The Laryngological Society of London was founded by Semon in 1893, and he was its President for three successive years, 1894-1896. When later the Royal Society of Medicine was incorporated, Semon took a leading part in bringing together the British Laryngological, Rhinological, and Otolological Societies, and the Laryngological Society of London. By their coalescence the Laryngological Section of the Royal Society of Medicine was constituted. He continued to devote his best energies to the meetings of the Section, and by his genial presence, enthusiasm, and scientific work he contributed greatly to its success. He was president of the Section of Laryngology at the annual meetings of the British Medical Association in Glasgow in 1888 and in London in 1895.

Semon's original contributions to his speciality were of great value, but far too numerous even to mention here in detail. Perhaps the more notable were those on laryngeal neurology and on malignant growths of the larynx, the series of articles on diseases of the pharynx, larynx, and trachea contributed to Allbutt's *System of Medicine* in collaboration with Watson-Williams, on malignant growths of the larynx in the *Encyclopaedia Medica*, and articles in Heath's *Dictionary of Surgery*, and in Heymann's *Handbuch der Laryngologie*. He was the founder and for twenty-five years the editor of the *Internationales Centralblatt für Laryngologie und Rhinologie*, while his own *Forschungen und Erfahrungen*, 1880-1910, is a work of great value and lasting interest.

In the early eighties his clinical investigations had led him to the conclusion that in all progressive organic lesions of the centres of trunks of the motor laryngeal nerves, the abductors of the vocal cords succumb much earlier than the adductors. He strengthened his deductions, based on clinical work by experimental research in conjunction with Sir Victor Horsley. After a long controversy with various noted laryngologists, who sought to explain the facts by other theories, Semon successfully upheld the accuracy of his observations, and succeeded in establishing his thesis as a clinical fact of considerable interest and import, which is known and recognized as "Semon's law." Semon's contributions to the early diagnosis and operative technique of malignant growths of the larynx, more especially the indications for thyrotomy in intrinsic laryngeal cancer, were notable. The successful results obtained from removal by laryngo-fissure in suitable cases by Butlin induced Semon to adopt that route at a time when the intralaryngeal method was practised and commended by some leading European authorities. But it was essentially Semon's elaborated and accurate methods of differential diagnosis, of such practical import for the early recognition of malignancy while still amenable to successful eradication by laryngo-fissure, that placed this operative measure in the unassailable position it has continued to occupy. In Semon's own hands a lasting cure was obtained in over 80 per cent. of the cases he operated on for malignant laryngeal growths, and through the adoption of his successful diagnostic and operative practice, by most laryngologists throughout the world, his work has proved of immense and lasting benefit to humanity. Furthermore, these methods of early diagnosis, by avoiding the necessity for more drastic and maiming operations, have been the means not only of saving many lives, but a large number of patients who have undergone a radical operation for laryngeal cancer are restored, without losing their voice, to a useful and happy life.

Semon's scientific mind could not tolerate inaccuracy, and he was relentless in pursuing what he deemed error in observation or statement in others. In his early days prejudice against specialism and specialism was in many quarters strong, and sometimes found intemperate expression. Semon was always ready to speak for the defence; he did not mince his words, and became engaged in several rather heated controversies. He was a regular attendant and frequent speaker at the meetings of the medical societies. His reputation as a consultant for diseases of the throat brought him a large laryngological practice, which he continued to enjoy till he retired in 1911 at the zenith of his career. Expression was given to the esteem in which he was held at the banquet organized to mark the occasion of his retirement, when the late Sir Henry

Butlin presided over a gathering comprising the great majority of British laryngologists, as well as many distinguished foreigners and a large number of musicians, artists, literary and other friends. A sum of £1,040, subscribed as a testimonial expressive of their warm regard for him and appreciation of his life's work, he presented to the University of London to establish a trust for the purpose of awarding a commemorative bronze medal for the best work in the treatment of diseases of the throat and nose and to found a lectureship to be called the "Semon Lectureship in Laryngology." Anxious as he ever was to promote the authoritative position of the Laryngological Section of the Royal Society of Medicine, it was by Semon's special request that two members of the board by which the lecturer is appointed are elected by this Section.

Semon was honoured by the confidence of H.M. Queen Victoria, who conferred the honour of knighthood upon him in 1897; later he was appointed Physician Extraordinary to H.M. King Edward VII and received the K.C.V.O. in 1905. In 1888 he had received the Order of the Red Eagle, and in 1894 the German Emperor conferred on him the title of Royal Prussian Professor. During his lifetime he was honoured by almost every laryngological society in Europe and America. He was an Honorary President of the Madrid Laryngological Society and Honorary Fellow of the Italian, Petrograd, and American Laryngological Associations. To no other laryngologist has fallen such a world-wide recognition as came to Felix Semon. With it all, there was never a kindlier and more considerate friend to younger practitioners, ever anxious to bring out and encourage the latent talent that he was often the first to discover and to promote.

We have but touched on the main features of Semon's life as a physician known for his work in laryngology, yet we cannot leave our tribute to his memory without reference to some of his other attributes. He was not only an accomplished pianist, but as a composer displayed talent of no mean order; as a raconteur he was delightful, as a friend he was ever true and steadfast, a thorough sportsman, a fearless rider and a keen deer stalker as the many heads adorning his mansion at Great Missenden testify.

Semon's geniality and courtesy, his vivacious conversation and generous hospitality, rendered him a conspicuous figure in society, but by his many friends he was loved for his warm heart and unswerving fidelity. Latterly increasing ill health compelled him to live a very quiet life, and almost entirely at Rignalls, which he had designed and built, devoting much of his time to literary pursuits and to his garden. A little more than a year ago he underwent a severe operation, and, though he recovered from this, he never regained his old energy, but his last illness, which so rapidly proved fatal, was quite unexpected.

To the last he never failed to maintain a keen interest in affairs, and particularly in the speciality he adorned, and all that concerned the progress and advancement of laryngology in this country. A recent example of this is furnished in connexion with the famous Onodi collection. "This country ought to possess the collection," said Semon to the writer on hearing from the late Professor Onodi's son that it was for disposal; and it was Semon's initiative that led to the collection being brought to London to that end, although after its arrival here, as is common knowledge, the credit of securing it for this country belongs entirely to two of his colleagues and to those who supported their successful effort.

He married in 1879 Louise Dorette Augusta, daughter of H. Redeker. To Lady Semon and their three sons we tender our deepest sympathy. His eldest son, Dr. Henry Semon, is practising as a dermatologist. In the late war Felix Semon himself repeatedly offered his services, but at his advanced age he had to be content with sending his three sons.

SIR CHARLES ALEXANDER CAMERON, C.B., M.D.,
Medical Officer of Health, Dublin.

We announced briefly in our last issue the death of Sir Charles Cameron, C.B., which occurred in Dublin on February 28th, in his 91st year. Born in Dublin on July 16th, 1830, the son of Captain Ewen Cameron, of Lochaber, Charles Alexander Cameron received his early education in Dublin, afterwards going to Germany, where he graduated Ph.D. in 1856. He obtained the L.R.C.P.I. in 1868, becoming a Fellow of the College in 1893, and he

became F.R.C.S.I. in 1874. He held the D.P.H. of Cambridge and of the Irish College of Surgeons, and was made an honorary M.D. of the Royal University of Ireland in 1896. In 1867 he was elected professor of hygiene in the Royal College of Surgeons of Ireland, and for more than half a century he had charge of the public health of the city of Dublin, where his greatest public services were rendered. Upon many occasions his opinion was invited by public bodies abroad as well as in Ireland, and he always readily placed his great experience at their disposal. As a sanitary scientist his name was known throughout Europe, and he was elected to the honorary membership of a number of foreign learned societies, including the Swedish Academy of Medicine and the Hygienic Associations of Paris and Bordeaux. He was a past-president of the Royal Institute of Public Health, of the Leinster Branch of the British Medical Association, and of the Irish Medical Schools' and Graduates' Association. In 1884 he was elected president of the Royal College of Surgeons of Ireland, and in the same year the honour of knighthood was conferred upon him by Queen Victoria "in recognition of his scientific researches and his efforts to improve the state of public health in Ireland." The distinction of a Companionship of the Bath was bestowed upon him in 1899, and in 1902 he was awarded the Harben gold medal by the Royal Institute of Public Health. The list of works from his pen is long, and includes volumes on the chemistry of agriculture, the chemistry of food and a manual of hygiene, but perhaps his chief works were *The History of the Royal College of Surgeons in Ireland* and *A History of Medicine in Ireland*. Sir Charles Cameron was a man of extraordinary energy and activity, but as he always worked in a most methodical manner he never seemed hurried. He found recreation in a change of occupation, and the holidays he allowed himself were spent chiefly in attending medical and other congresses. He held high office in Irish Freemasonry, and he was the founder of the Corinthian Club, a well-known social club in Dublin. He married in 1862, Lucie, daughter of the late Mr. John Macnamara, a noted Dublin solicitor; she died in 1883, and he is survived by a son and two daughters.

PHINEAS SIMON ABRAHAM, M.D.

Consulting Dermatologist to the West London Hospital,
Hammersmith.

WE have to record with regret the death, on February 23rd, of Dr. Phineas Simon Abraham in his 75th year. He had never quite recovered from the serious illness from which he suffered last year, and had been failing for some weeks before his death. He was born in Jamaica; intending to become a mining engineer, he entered University College, London, and took the B.Sc. degree of the University of London. He attended also the Royal College of Science, Dublin, where he was a royal exhibitor. Entering Trinity College, Dublin, he was first senior moderator in 1871, and gold medalist in natural science and scholar. He received the M.A. with distinction from the University of Dublin, and entered St. Bartholomew's Hospital with a science exhibition and scholarship in 1876. He took the diploma of F.R.C.S.I. in 1880, having in the previous year been appointed curator of the museums of the Royal College of Surgeons, Dublin. In 1885 he returned to London on appointment to be lecturer on physiology and histology at the Westminster Hospital Medical School. Shortly afterwards he was appointed dermatologist to the West London Hospital, and became a lecturer on that subject in the Post-Graduate College there. He was also at one time surgeon to the Hospital for Diseases of the Skin, Blackfriars. He was one of the principal founders of the Royal Academy of Medicine of Ireland and of the Dermatological Society of Great Britain and Ireland. He was president of the West London Medico-Chirurgical Society in 1910-11; he had also been president of the Irish Medical Schools' and Graduates' Association. During his term of office he founded and endowed the triennial gold medal awarded by the West London Medico-Chirurgical Society for distinguished services or for exceptional heroism in the discharge of medical duties. When the annual meeting of the British Medical Association was held in London in 1910 he was president of the Section of Dermatology. He was the author of many articles on dermatological subjects, among others those on leprosy and several other diseases of the skin in Sir Clifford

Allbutt's *System of Medicine*. He took a particular interest in leprosy, was medical secretary of the National Leprosy Fund in 1889, and represented this country at the International Lepra Conference in Berlin in 1897. He edited also the *Journal* of the Leprosy Investigation Committee. Dr. Abraham, whose genial disposition won him many friends, is survived by his widow and a daughter.

The Services.

R.A.M.C. ROLL OF HONOUR.

THE official Roll of the Officers of the Royal Army Medical Corps who laid down their lives in the great war is now published. The total number of names given is 709, divided as follows:

Old and New Armies.		Territorial Force.	
Major-Generals ...	1	Colonels ...	2
Colonels ...	8	Lieutenant-Colonels	13
Lieutenant-Colonels	17	Majors ...	16
Majors ...	25	Captains ...	77
Captains ...	360	Lieutenants ...	5
Lieutenants ...	185		
	596		113

The list includes 4 V.C.s and 23 D.S.O.s. There are also the names of Sir Victor Horsley and Sir Charles Ball, 5 recipients of the C.M.G., and 2 of the O.B.E.

The Officers' Roll, comprising over 40,000 names in all, may be purchased from His Majesty's Stationery Office through any bookseller.

NEW RATES OF PAY FOR R.A.M.C. OFFICERS IN INDIA.

The following revised rates of pay have been approved for officers of the R.A.M.C. in India. The new rates have effect from January 1st, 1920:

	Rs. per Mensem.
Lieutenant ...	650
Captain ...	800
Captain, after 6 years' total service ...	900
Captain, after 10 years' total service ...	950
Major ...	1,100
Major, after 15 years' total service ...	1,250
Major, after 18 years' total service ...	1,400
Lieut.-Colonel ...	1,550
Lieut.-Colonel, after 20 years' total service ...	1,650
Lieut.-Colonel, after 25 years' total service ...	1,850

Charge allowance for command of a British station hospital and specialist pay under para. 155 (d) iii and iv are admissible in addition.

DEATHS IN THE SERVICES.

COLONEL DAVID ERSKINE HUGHES, Bombay Medical Service (retired), died at Kensington on February 9th, aged 77. He was born on June 21st, 1843, the son of the late George Hughes, Writer to the Signet, Edinburgh; he was educated at Edinburgh, where he graduated M.D. in 1864, also taking the L.R.C.S. Edin. in the same year. He entered the I.M.S. on March 31st, 1866, became colonel on September 15th, 1892, and retired on September 15th, 1897. After sixteen years' military service he was appointed civil surgeon of Belgaum in 1882, and eight years later of Poona, the prize station of the Bombay Presidency. On promotion to the administrative grade he was posted as principal medical officer of the Bombay and Aden districts, retiring after his five years' tour of office in that part. Lieut.-Colonel George Wardlaw Milne, R.A.M.C., died at Nordrach-on-Dee on February 7th. He was educated at the Universities of Edinburgh and Glasgow, graduating M.B. and C.M. Glasg. in 1901, and M.D. in 1911. He served as a civil surgeon in the South African war, gaining the Queen's medal; and subsequently joined the West African Medical Staff as a district medical officer in Nigeria; while in Africa he served as surgeon to the Uri-Omonohaa Expedition. He took a temporary commission as lieutenant in the R.A.M.C. on October 12th, 1914, became captain after a year's service, and on December 23rd, 1918, was promoted to temporary lieutenant-colonel.

Universities and Colleges.

UNIVERSITY OF OXFORD.

At a Congregation held on March 3rd the degree of Bachelor of Medicine was conferred on Philip G. Doyne.

UNIVERSITY OF CAMBRIDGE.

At a Congregation held on March 5th the Board of Electors to the Sir William Dunn Professorship of Biochemistry was appointed as follows: Sir W. J. Pope, Mr. F. E. Blackman, Professor T. B. Wood, Mr. W. B. Hardy, and Professors W. M. Bayliss, J. N. Langley, J. Stanley Gardiner, and C. J. Martin.

The following medical degrees were conferred:

M.D.—E. J. Bradley.
M.B., B.Ch.—A. G. Shurlock, N. W. Jenkin, H. B. Yates.
M.B.—E. E. Llewellyn.
B.Ch.—F. N. Sidebotham.

UNIVERSITY OF LONDON.

THE following have been recognized as teachers of the University in the subjects and at the institutions indicated:

University College: Dr. G. Anrep (Physiology). *King's College:* Dr. James A. Hewitt (Physiology). *St. Thomas's Hospital Medical School:* Mr. B. C. Maybury, Mr. C. Max Page, and Mr. W. H. C. Remanis (Surgery). *Guy's Hospital Medical School:* Dr. N. Mutch (Pharmacology). *London Hospital Medical College:* Dr. C. B. Goulden (Ophthalmology). *Middlesex Hospital Medical School:* Dr. Eric L. Pearce Gould (Surgery), Dr. W. B. Tuck (Chemistry). *Royal London Ophthalmic Hospital:* Mr. B. T. Lang (Ophthalmology).

The Senate has resolved that in and after July, 1921, the first examination for medical degrees commence on the first Monday in July.

The regulations in the Faculty of Medicine for internal and external students (Red Book, 1920-21, pp. 268-9; Blue Book, September, 1920, p. 251) have been amended by the addition of the words "other than for Branch V" after the words "any candidate for the M.D. degree," and by the deletion of the words "in Branch V (State Medicine) of the thesis . . . written and of the practical portions of the examination."

Particulars regarding a further course of lectures on mental deficiency supplemented by a course of clinical instruction, arranged in co-operation with the Central Association for the Care of the Mentally Defective, to be held from May 23rd to June 4th, can be obtained on application to Miss Evelyn Fox, care of The University Extension Registrar, University of London.

Professor H. R. Kenwood has been appointed the representative of the University at the Congress of the Royal Sanitary Institute to be held at Folkestone in June. Dr. G. Newton Pitt has been reappointed to the Senate by the City and Guilds of London Institute for the period 1921-25. Professor Anne Louise McIlroy, O.B.E., has been admitted to the Faculty of Medicine.

Presentation Day will be held at the Albert Hall on May 5th instead of May 4th as formerly arranged.

Eight Beit fellowships for scientific research, of the annual value of £175, will be awarded in July. Forms of applications (which must be received by April 19th) and information can be obtained by letter only addressed to the Rector, Imperial College, South Kensington, S.W.7.

SOCIETY OF APOTHECARIES OF LONDON.

THE following candidates have passed in the subjects indicated:

- SURGERY.**—†W. A. Bryce, *A. R. Crane, †Z. Khaled, †G. G. Rigby, *†B. W. Roffey.
- MEDICINE.**—†W. A. Bryce, *†O. G. Fisk, *M. Foley, *B. W. Roffey, *†H. W. Swann, †J. Solomonoff, *†M. Tcherny.
- FORENSIC MEDICINE.**—W. A. Bryce, E. C. T. Clonston, O. G. Fisk, M. Foley.
- MIDWIFERY.**—A. G. L. Brown, R. E. Williams.

The Diploma of the Society has been granted to Messrs. Z. Khaled and H. W. Swann.

Medical News.

THE portrait of Sir Anthony Bowlby, by Sir William Llewellyn, R.A., will be presented to him in the Great Hall of St. Bartholomew's Hospital on Friday next, March 18th, at 3 o'clock. It will then be handed by Sir Anthony Bowlby to Viscount Sandhurst, the Treasurer, who will receive it on behalf of the governors.

WHEN the Prince of Wales attends the presentation ceremony at the University of London on May 5th to receive the honorary degrees of Master of Commerce and Doctor of Science a presentation will be made to him by graduates and teachers. It has been resolved that the presentation shall consist of an illuminated fourteenth-century manuscript containing a narrative in French verse of the life and exploits of Edward, Prince of Wales—the Black Prince. It contains a fine miniature of the Black Prince, with the motto, "Ich Dene." This spelling is of interest, as it shows the original form of the Prince's motto, which is characteristic of the Gelderland dialect, and not the high German form, "Ich Dien," which became customary later. The Principality of Gelderland was at the time linked to this country by a strong alliance. Subscriptions from graduates and teachers, ranging from two guineas to 10s. 6d., and from undergraduates, ranging from 10s. to 2s. 6d., are asked for to defray the cost of purchasing the manuscript; they should be sent to Dr. Walter W. Seton, at the University, South Kensington, S.W.

AN "At Home" was given by the Lady Emmott, J.P., Mrs. Anstruther, and Dr. Christine Murrell at the London (Royal Free Hospital) School of Medicine for Women on March 3rd, when the laboratories and lecture theatres were open to the guests; and short talks on the past, present, and future of the school and hospital were given by Lady Barrett, C.B.E., M.P., M.S., Dr. Louisa Garrett Anderson, C.B.E., Professor Winifred Cullis, O.B.E., and Dr. Dorothy Hare, C.B.E.

PROFESSOR LEO T. MCILROY, M.D., who has just been appointed by the Senate of the University of London Director of the Unit of Obstetrics and Gynaecology at the London School of Medicine for Women—the first of its kind organized in London—was present at the afternoon party given by their Majesties at Buckingham Palace on March 3rd.

DURING the celebration of foundation week at University College, London, Sir Francis Younghusband, K.C.S.I., will give the foundation oration before the Union Society on Thursday, March 17th, at 8.30 p.m.

SIR WILLIAM COLLINS has been appointed Chairman, and Sir Thomas Barlow Vice-Chairman, of the Central Council for District Nursing in London.

THE Commission appointed by the National Council for Combating Venereal Diseases and sent out to the Far Eastern Ports under the aegis of the Colonial Office has completed its itinerary and will arrive in England on March 14th. The medical member is Dr. Rupert Hallam of Sheffield.

DR. R. A. LYSTER, County Medical Officer for Hampshire, has been appointed a member of the Central Midwives Board on the nomination of the Society of Medical Officers of Health.

AT a meeting of the Illuminating Engineering Society in the house of the Royal Society of Arts, John Street, Adelphi, at 8 p.m. on Thursday, March 17th, there will be a discussion on motor-car headlights.

AT the York Assizes on March 3rd, Leonard Mayland, described as a herbalist, pleaded not guilty before Mr. Commissioner Hugo Young, K.C., to an indictment charging him with performing an illegal operation on a domestic servant on November 24th. The jury found the prisoner guilty and he was sentenced to one year's imprisonment.

Letters, Notes, and Answers.

As, owing to printing difficulties, the JOURNAL must be sent to press earlier than hitherto, it is essential that communications intended for the current issue should be received by the first post on Tuesday, and lengthy documents on Monday.

ORIGINAL ARTICLES and LETTERS forwarded for publication are understood to be offered to the BRITISH MEDICAL JOURNAL alone unless the contrary be stated.

CORRESPONDENTS who wish notice to be taken of their communications should authenticate them with their names—of course not necessarily for publication.

AUTHORS desiring reprints of their articles published in the BRITISH MEDICAL JOURNAL are requested to communicate with the Office, 429, Strand, W.C.2, on receipt of proof.

IN order to avoid delay, it is particularly requested that ALL letters on the editorial business of the JOURNAL be addressed to the Editor at the Office of the JOURNAL.

THE postal address of the BRITISH MEDICAL ASSOCIATION and BRITISH MEDICAL JOURNAL is 429, Strand, London, W.C.2. The telegraphic addresses are:

1. EDITOR of the BRITISH MEDICAL JOURNAL, *Aitology, Westrand, London*; telephone, 2650, Gerrard.
2. FINANCIAL SECRETARY and BUSINESS MANAGER (Advertisements, etc.), *Articulate, Westrand, London*; telephone, 2650, Gerrard.
3. MEDICAL SECRETARY, *Medisecra, Westrand, London*; telephone, 2650, Gerrard. The address of the Irish Office of the British Medical Association is 16, South Frederick Street, Dublin (telegrams: *Bacillus, Dublin*; telephone, 4757, Dublin), and of the Scottish Office, 6, Rutland Square, Edinburgh (telegrams: *Associate, Edinburgh*; telephone, 4361, Central).

QUERIES AND ANSWERS.

"J. T." asks for information as to the cause of cramp. What part is played respectively by the circulation, nerves, and muscles.

INCOME TAX.

"RESIDENT MEDICAL OFFICER" receives from his Board a monthly statement in the following terms:

	£	s.	d.
Salary for month	42	18	10
Less deduction for supplies	10	16	8
	32	2	2
Less superannuation	0	17	2
	31	5	0

The "deduction for supplies" represents the value of the board and lodging supplied; he asks whether he is assessable on the gross sum or on the net amount excluding the £10 16s. 8d. in question.

* Our correspondent does not state the terms of his appointment. If he was appointed at a salary of £375 with board and lodging provided, then the value of the latter is not chargeable to tax; if, however, he was appointed at a salary of, say, £500, on condition that he bore the reasonable cost of

his board, then the £500 is taxable. The point is that an emolument in kind is not within the liability, and the monthly valuation of that emolument does not seem to affect the question.

"J. B." states that during his absence on military service his "practice was run at a loss if the usual expenses are allowed." He asks whether he can claim repayment of tax in respect of the losses.

*. * Such claims are required to be made within the year following that in which the loss was incurred, though our correspondent might perhaps obtain some extension of that time limit in view of the cause of his absence. But we have some doubt as to whether "the usual expenses," including proportion of rent, rates, etc., could be claimed if the work of the practice was being performed by his colleagues as from other premises.

"S. H. S." inquires as to the method by which the allowance for the cost of renewal of a car is made.

*. * The cost is treated as a professional expense as for the year in which it is incurred; it is not dealt with as a deduction from the average of the three years, though that is the method of the "depreciation" allowance. Thus £250 expended in 1920 would not affect the 1920-21 assessment, which is based on the average profits of 1917, 1918, and 1919; if the three years' average system holds good for the future the allowance will work itself out accordingly, but whether that system will continue will presumably not be known until the Chancellor of the Exchequer makes his Budget statement.

LETTERS, NOTES, ETC.

AN ACID DENTIFRICE.

DR. W. J. HENSON (London, W.) writes: For some years past I have been annoyed by the fact that my children's teeth, in spite of heavy dentist's bills, have been rapidly and constantly decaying while their grandparents' teeth are still fairly sound. On inquiry I found that the latter from their youth used only a mixture of willow charcoal and salt while my children have spent many pounds in the largely advertised tooth creams and pastes, chiefly of American origin, that have become so popular. I have heard more than one of my patients say that dentists had complained that doctors took little account of the great prevalence of pyorrhoea and dental caries. I have, however, been diligently seeking the cause and a remedy for a number of years, but it was only on reading Dr. Sim Wallace's pioneer work and Professor Pickere's Cartwright Prize Essay of the Royal College of Surgeons on the subject, in which the latter emphasizes the fact that the prime cause of these diseases is the alkaline dentifrices which are still flooding the market under glowing colours, that I was put on the right track. I have tested every well-known tooth paste and powder, but I have not found a single preparation which was not powerfully alkaline, the only result being the retarding of the natural flow of the saliva, which is Nature's own preventive of decay. I also found that carbolic tooth powder, although a very pleasant and popular dentifrice, is another serious cause of dental troubles. Apparently the reason of the disuse of willow charcoal was that being insoluble it was apt to be brushed in between the teeth and gums and there leave a black line. Seeing a notice of "uoline" nitrate, a colourless salt prepared from willow charcoal, I tested it and found it apparently possessed all the preservative qualities of the charcoal itself. I combined this with fruit acids and a soluble antiseptic, with the result that a preparation has been produced and has proved highly efficacious to my patients and members of my own family. I have not yet seen a single case of recurring dental decay or pyorrhoea in any who have used it. Messrs. W. E. Lowe and Co., Ltd., of 8, Stafford Street, Bond Street, W., are now preparing this in paste form under the title of "Willocine" dentifrice.

THE DENTISTS BILL.

MR. J. MENZIES CAMPBELL, L.D.S., D.D.S. (Glasgow, W.), in the course of a letter on this subject, writes:

The Dentists Bill, 1920, which is the outcome of a report by a Departmental Committee appointed to inquire into the extent and gravity of the evils of dental practice by persons not registered under the Dentists Act, 1878, has now been presented to Parliament, but it is full of loopholes and treats symptoms only. Unqualified dental practice is not prohibited, and it seems grossly unfair that those who uphold the law are to be compelled to make very substantial sacrifices without any guarantee that the practice of dental surgery will only be carried on in the future by registered dentists. An Act was passed on July 22nd, 1878, prohibiting unqualified dental practice in the future, and the names of those in practice on that date were inserted in the *Dentists' Register*. If Parliament proposes to reopen the *Register*, the medical and dental professions are justified in demanding that the defects in the 1878 Act shall not be repeated. Untrained individuals pursue the calling in Great Britain to-day, and every medical and dental practitioner is aware of the irre-

parable damage that ensues. It is interesting to note that there are, amongst the unregistered dental practitioners in our cities, those who previously earned their livelihood as scene-shifters in theatres, drapers' and grocers' assistants, butchers and miners. This bill purposes placing on the *Dentists' Register* the names of all individuals who have been in practice for five years and conferring on them the title of "dentist" or "dental practitioner." If this should be done, an opportunity will not thereafter be afforded the public of discriminating between those who have undergone a four years' course of training and passed examinations, and those who have been presented with a title by an Act of Parliament. A very glaring omission from the bill is a clause constituting a tribunal to consider and investigate all claims for admission to the *Register*.

Another very objectionable feature in the bill is the retention of dental companies. The General Medical Council and the British Dental Association are both entirely opposed to these companies, and the latter suggests that the practice of dentistry by companies be entirely prohibited, with an equitable arrangement for present shareholders withdrawing their money from business. If this bill be passed, however, the public must be prepared for the rapid growth of such undesirable concerns all over the country. This is a serious matter for the general public, who expect to receive individual attention from licentiate dentists, and, further, no incentive will be offered to young men to follow the profession of dentistry, because these numerous trading companies would throttle private practice.

Every L.D.S. earnestly desires to see the profession augmented, but no one is prepared to allow it to be ruined in an attempt to provide an alleged cure for the irregularities existing at the present time. Surely justice would have been meted out to the present unregistered practitioners if those who had been in practice on their own behalf for a period of five years were admitted to a special list and given the description of "operating dental mechanic," while canvassing and advertising were prohibited; and those thus admitted would be encouraged to qualify for the dental diploma without the necessity of passing the preliminary examination. It might also be desirable to modify the professional studies for this body of men. Those who were not admitted to the special list could easily procure a living at their own trade of mechanical dentistry. There are many other objectionable features in the bill, which space does not here permit me to discuss, but every effort should be made to compel politicians to leave the dental profession under the guidance and control of the General Medical Council, which is the proper authority to suggest any modifications in the curriculum.

THE LATE MR. J. H. MCFADDEN.

DR. H. C. ROSS (London, W.) writes: A tribute is due to the memory of John Howard McFadden, who died at Philadelphia on February 16th, aged 70. He was one of those unostentatious philanthropists who help to make progress. Although he knew that he was attacking a problem which he could never hope to solve, he cheerfully started and entirely supported for six years a cancer research organization at the Lister Institute of Preventive Medicine in London. He gave *carte blanche*, and later on extended the investigations to other branches of medical research, even sending expeditions to investigate pellagra in the United States. The researches made in association with the Home Office into the cause of industrial cancer at the briquette works are to the credit of Mr. McFadden, who received the thanks of the Secretary of State for what he called his "spade work"; he never courted publicity. John H. McFadden was a remarkable personality. He was a judge of pictures, and collected a fine gallery of eighteenth-century English art.

"TWILIGHT SLEEP": CORRECTION.

WE regret that in the report of Dr. Haultain's paper on "Twilight Sleep" in our last issue a misprint occurred through damage to the type after it had left this office. In the 29th line, first column of page 341, the dose of hyoscine should, of course, be 1/150 grain and not 1/50.

VACANCIES.

NOTIFICATIONS of offices vacant in universities, medical colleges, and of vacant resident and other appointments at hospitals, will be found at pages 30, 31, 34, 35, and 36 of our advertisement columns, and advertisements as to partnerships, assistantships, and locum tenencies at pages 32, 33, and 34.

THE appointments of certifying factory surgeons at Clevedon (Somerset), Frome (Somerset), and Horsforth (Yorks West Riding) are vacant.

SCALE OF CHARGES FOR ADVERTISEMENTS IN THE BRITISH MEDICAL JOURNAL.

	£	s.	d.
Six lines and under	0 9 0
Each additional line	0 1 6
Whole single column (three columns to page)	7	10	0
Half single column	3 15 0
Half page	10 0 0
Whole page	20 0 0

An average line contains six words.

All remittances by Post Office Orders must be made payable to the British Medical Association at the General Post Office, London. No responsibility will be accepted for any such remittance not so safeguarded.

A British Medical Association Lecture

ON

SOME RECENT ADVANCES IN THE PHYSIOLOGY OF RESPIRATION, RENAL SECRETION, AND CIRCULATION.*

BY

J. S. HALDANE, M.D., F.R.S.,

OXFORD.

IN this lecture I shall endeavour to summarize the results of a number of recent investigations, with most of which I have been closely associated, on respiration, renal excretion, and circulation, and to point out, as far as I am able, their significance in helping us to understand the symptoms of disease and the real characters of that marvellous living body with which our profession has to deal. I will begin with respiration, as it was from the side of respiration that I myself, in conjunction with Professor Lorrain Smith, Professor Pembrey, Dr. Priestley, Professor Boycott, Dr. Douglas, and others who worked along with me, approached the subjects of this lecture.

REGULATION OF CO₂ PRESSURE IN ARTERIAL BLOOD.

The rate, depth, and regularity of breathing vary greatly at different times. A graphic record of my breathing while I am giving this lecture would, for instance, present an apparent picture of hopeless irregularity in every direction. If, however, we collect the expired air minute by minute we find that the samples obtained do not vary very much in composition. This suggests underlying regulation; and in order to test this more closely Priestley and I, about eighteen years ago, investigated the air present in the lung alveoli, of which we found that a sample can easily be obtained by catching the last parts of the air expired in a deep expiration. This investigation showed that whether the breathing was rapid or slow, provided only that there was no voluntary interference with its depth, the mean percentage of CO₂ in the alveolar air was maintained extraordinarily steady—far more steady than in the expired air, which is, of course, a variable mixture of the alveolar air with air contained in the air passages at the beginning of expiration.

Addition of moderate amounts of CO₂ to the inspired air, or moderate increases, owing to muscular exertion, of the amount of CO₂ produced in the body, hardly altered the alveolar CO₂ percentage except momentarily. The breathing was simply increased sufficiently to keep the alveolar CO₂ percentage almost exactly the same. Nor did great increases or moderate diminutions in the oxygen percentage of the inspired air alter the CO₂ percentage. By varying the barometric pressure we showed also that it is the partial pressure or concentration of CO₂ in a given volume of air that is kept so constant. At a barometric pressure of two atmospheres, for instance, the percentage of CO₂ which is maintained in the alveolar air is only half that at one atmosphere; but this means that the partial pressure or concentration of CO₂ is the same.

Now the arterial blood leaving the lungs is saturated with CO₂ at the same partial pressure as exists in the alveolar air; and this arterial blood in its turn saturates the respiratory centre at a similar partial pressure, and by so doing stimulates it to activity. The latter saturation, however, takes a little time, since the capacity of the body liquids for holding CO₂ in combination and simple solution is relatively large. The breathing, therefore, responds gradually and smoothly to any change in the alveolar CO₂ pressure, just as if the respiratory governor was associated with a fly-wheel; and at the same time the vagus reflex which governs the depth of breathing is accurately adjusted so that depth and frequency harmonize with one another. The response is extremely delicate. We found that in most persons there is about 5.6 per cent. of CO₂ in the alveolar air. If, by adding sufficient CO₂ to the inspired air, this percentage was raised by 0.2, the breathing during rest was doubled. If, on the other hand, the mean percentage was lowered by 0.2 by voluntary forced breathing, natural breathing ceased for the time, a temporary apnoea being produced.

* Delivered before the Edinburgh Branch of the British Medical Association, March 4th, 1921.

Calculation shows that the corresponding increase or diminution in the free CO₂ contained in the arterial blood was only two parts by weight in a million of blood. This at once affords an idea of the astounding delicacy of physiological regulation. Physiology is an exact quantitative science, and for the purpose of these investigations I had to improve the existing methods of gas analysis. But what we are really measuring in physiology is the accuracy of maintenance of organic regulation, and this is something very different from what the physicist or chemist is engaged in measuring.

REGULATION OF THE REACTION OF ARTERIAL BLOOD.

Now, when carbon dioxide goes into solution in water it acts as an acid, though a very weak or feebly ionized one. Hence its old name, carbonic acid. Since an investigation by Walter, from Schmiedeberg's laboratory, in 1877, it has been known that in poisoning by dilute acids the breathing is greatly increased, and that accompanying the increased breathing there is greatly increased excretion of ammonia in the urine. It appeared, also, that the increased formation of ammonia in the body was a compensatory process, tending to neutralize the acid. It was the presence of a great excess of ammonia in the urine in diabetic coma that caused von Jaksch to suspect that diabetic coma is a state of acid poisoning or acidosis, and so led to the discovery that aceto-acetic and oxybutyric acids are formed within the body in large amounts in diabetic coma. Shortly after Priestley and I published our work on the alveolar air Pembrey and Beddard found that in diabetic coma the alveolar CO₂ percentage falls to less than a third of normal, but returns towards normal when the symptoms are relieved by sodium bicarbonate. This and various other pieces of evidence led us to conclude that it is probably as an acid, and in conjunction with other acids, that CO₂ acts in the regulation of breathing. But this theory was first established on a quantitative basis by the investigations of Hasselbalch of Copenhagen. He found that by taking an alkali-forming or acid-forming diet he could alter distinctly the percentage of CO₂ to which the alveolar air is regulated during rest, but that the alteration was just such as to keep the reaction or hydrogen ion concentration of the arterial blood steady in so far as the available physical and chemical methods enable us to estimate the steadiness. Putting together Hasselbalch's results and our own, we were able to conclude that the reaction of the blood is regulated with a delicacy which is almost inconceivable, and which can only be followed very roughly by existing physical and chemical methods, though much more closely by the observation and interpretation of symptoms—by "diagnosis." Every normal response of the breathing to increased muscular exertion or other causes leading to increase in alveolar CO₂ percentage betokens a temporary acidosis or diminution in the blood's alkalinity. Calculation shows that a deficiency of one part by weight of ionized hydrogen in about one million million parts of blood suspends completely the activity of the respiratory centre.

Let us glance very shortly at the means by which the blood reaction is regulated. The first means is by regulation of the breathing so as to vary the amount of carbonic acid in the arterial blood. This process of regulation acts very rapidly, but, of course, cannot in the long run deal with the non-volatile acids in the blood. The temporary acidosis of muscular exertion, or the temporary alkalosis of forced breathing, is rapidly compensated approximately by variations in the breathing. Another interesting form of compensation has quite recently been demonstrated by Dodds.¹ When food is taken there is a rapid secretion of dilute HCl into the stomach, followed about an hour later by alkaline secretion into the small intestine. The gastric secretion of HCl leaves, of course, a temporary excess of alkali in the blood, and this promptly produces a quite marked compensatory rise in the alveolar CO₂ percentage, followed, about an hour later, by an equally marked fall while the alkaline secretion is being produced. A large dose of sodium bicarbonate will also produce a marked compensatory rise in the alveolar CO₂.

The second means of regulation is by varying the excretion of acid or alkali by the urine. Compared with variations in reaction of the blood, which is always slightly alkaline, the variations in reaction of normal urine are enormous. The acidity of average human urine

is mainly due to the presence in it of acid phosphate, and, as L. J. Henderson showed, large amounts of acid can be excreted as acid phosphate without the urine becoming more than slightly acid. The phosphate acts in this respect as a so-called "buffer" substance. In alkaline urine bicarbonate acts as a chief buffer substance, as was recently shown by Davies, J. B. S. Haldane, and Kennaway;³ and in the compensatory excretion of alkaline urine which occurs when a large dose of an alkaline substance is taken, or when forced breathing is continued for some time, very large amounts of bicarbonate are contained in the urine, so that it effervesces on addition of acid. They found also that when a man breathes air containing a good deal of CO₂ the urine becomes very acid and the ammonia in it increases. The same thing, as was recently shown in Professor Meakins's wards, occurs in asthma, since the obstructed breathing causes a rise in the alveolar CO₂ percentage.

The third means of regulation is by varying the amount of ammonia discharged into the blood; and this form of regulation is seen in all cases, so far as is known, where excretion of ammonia by the kidneys is occurring normally. When dilute acids are administered, even in large doses, to men or carnivorous animals, the compensation by increased formation of ammonia and increased excretion of acid is so perfect that compensation by increase of the breathing is difficult to demonstrate; hence the most prominent ordinary symptom of acidosis is lacking. It was recently shown by J. B. S. Haldane, however, that very marked symptoms of acidosis, with great increase of the breathing, can be produced by considerable doses of a quite neutral salt, ammonium chloride.⁴ The increased percentage of ammonia in the blood brings about reversal of the ordinary reaction by which, if the blood is insufficiently alkaline, ammonia is produced in the body at the expense of urea. As a result some of the ammonia of the ammonium chloride is converted into urea, leaving behind hydrochloric acid. The kidneys alone cannot deal with this acid at all completely, and soon the stock of phosphate which they require for excreting acid begins to run short. The respiratory centre is then called upon to redress the balance, and marked respiratory symptoms of acidosis are produced. This acidosis is relieved by administration of perfectly neutral sodium phosphate, which enables the kidneys to excrete much more acid. These experiments throw new light on renal acidosis, which may evidently be due partly to paralysis or impairment in the power of secreting acid urine and partly to impairment in the power of excreting ammonia, with consequent paralysis of the power of neutralizing acid with ammonia. If the diet is an acid-forming one, or if no food is taken, so that the body is living on its own tissues, there must, when the kidneys are disabled, be a tendency towards acidosis, with the well-known respiratory symptoms so often seen in Bright's disease.

REGULATION OF OXYGEN PRESSURE IN ARTERIAL BLOOD.

Respiration has another function to perform besides regulating the reaction of the body: it regulates the concentration of free oxygen. Recent investigations have tended to show more and more clearly that this regulation is no less exact than that of the reaction, and is of still more immediate importance. Under ordinary conditions regulation of the alveolar CO₂ percentage regulates also the alveolar oxygen percentage. But if under exceptional conditions the alveolar oxygen percentage or partial pressure falls abnormally, as when air poor in oxygen, or at a low atmospheric pressure, is respired, the breathing is increased. Evidently, however, the increased breathing will rapidly reduce the partial pressure of CO₂ in the blood, and this will in its turn reduce the breathing and so mask the respiratory effects of the want of oxygen. Want of oxygen, when produced gradually, has thus comparatively little effect on the breathing. We see this in the symptoms produced in airmen at very low atmospheric pressure, in carbon monoxide poisoning, and in gradual sinking from anoxaemia in phosgene poisoning, pneumonia, and various other clinical conditions. There is no marked struggle for breath. If, on the other hand, deficiency of oxygen in the arterial blood is produced so rapidly that there is not time for CO₂ to be washed out of the respiratory centre, the effects on the breathing may be very striking. Pembrey was the first to show that Cheyne-Stokes

breathing in a patient can be abolished by the administration of oxygen. Douglas and I then found that it can be produced in normal persons by conditions which permit of the comparatively rapid production of anoxaemia, followed by comparatively rapid relief. The respiratory centre is responding to the stimulus of want of oxygen; but as there is hardly any storage of free oxygen in the tissues, the fly-wheel action which exists when CO₂ is the stimulus no longer comes into play, and the respiratory centre "hunts," like an engine with a delicate governor but no fly-wheel. Cheyne-Stokes breathing is always a symptom of want of oxygen.

Since want of oxygen increases the breathing, it lowers abnormally the amount of free carbonic acid in the blood, and thus tends to produce a condition of alkalosis. This was shown recently in experiments at low atmospheric pressure in a steel chamber by Kellas, Kennaway, and myself.⁵ The urine became much less acid and the ammonia in it was greatly diminished. This implied that the alkali available in the body for combination with CO₂, or so-called "alkaline reserve," was being diminished in compensation for the deficiency in CO₂. The diminution in the "alkaline reserve" of the blood had previously been noticed, and had been attributed by myself and others to the development of an acidosis calculated to increase the breathing and thus relieve the want of oxygen. In reality there was no acidosis, but only the partial compensation by the kidneys and liver of a respiratory alkalosis. Yandell Henderson and Haggard had meanwhile made some striking experiments in which they showed that during forced artificial respiration, which produces a condition of extreme alkalosis, there occurs a great and rapid compensatory fall in the "alkaline reserve" of the blood, while during exposure to a very high percentage of CO₂ there occurs, conversely, a rapid compensatory rise in the "alkaline reserve."⁶ Diminished available alkali or "alkaline reserve" may thus be a sign of either alkalosis or acidosis. To interpret its actual meaning one must take into consideration all the physiological symptoms and conditions. Much confusion has arisen in recent medical and physiological literature through failure to interpret rightly a diminution in the so-called "alkaline reserve" of the blood. Diminution in "alkaline reserve" of the blood was quite wrongly identified with acidosis.

To understand physiological deficiency of oxygen or anoxaemia we must bear in mind that anoxaemia has no necessary connexion with the amount of oxygen which the blood is capable of liberating from its haemoglobin. What matters is the amount of free oxygen not combined with haemoglobin—in other words, the partial pressure of oxygen. The arterial blood of an anaemic patient, for instance, with only 40 per cent. of the normal haemoglobin, may be capable of liberating only half as much oxygen as the blood of a normal person who has been suddenly transported to a very high altitude, or who is suffering from dangerous want of oxygen during pneumonia. But the anaemic patient will probably have just as much free oxygen as usual in his arterial blood, and will thus, by bringing into play the circulatory regulation to which I shall presently refer, escape completely from anoxaemia during rest; while in the other cases the free oxygen in the arterial blood may be so seriously reduced that no circulatory compensation is possible and life is endangered.

The symptoms produced by even a comparatively slight amount of arterial anoxaemia are very serious. We can study them in their simplest form in mountain sickness. The extreme depression, nausea, headache, etc., are very striking. Accompanying these symptoms are slight cyanosis, Cheyne-Stokes breathing, and orthopnoea. Most attacks of mountain sickness as ordinarily met with in mountaineers can be recovered from without changing the altitude, since the body by increased active secretion of oxygen inwards, by compensation of the alkalosis, and by other means, ultimately triumphs over the disturbing conditions. But if the rarefaction of the air is too great the picture is a very different one: the central nervous system—in particular the respiratory centre—gradually fails, and death occurs gradually and quietly. A vicious circle has been produced and is never broken.

By accurate determinations of the percentage saturation of the haemoglobin in arterial blood, combined with close observation of symptoms and the effects of continuous addition of oxygen to the inspired air, Professor Meakins has recently thrown quite new light on

the pathology and treatment of pneumonia and other respiratory and circulatory affections? A continued deficiency of even one part by weight of free oxygen in a million of the blood present in capillaries may be very dangerous.

Anoxaemia may be caused in several different ways. Of these the simplest is that in which the concentration or partial pressure of oxygen in the alveolar air is insufficient to saturate the haemoglobin. This is the case in rarefied air or air very poor in oxygen. Another cause is thickening or clogging of the lung epithelium by exudation, so that oxygen cannot pass through it into the blood as readily as usual. A typical example of this is phlogene poisoning, and in such cases striking improvement is brought about by adding oxygen continuously to the inspired air so as to raise the diffusion pressure of the alveolar oxygen. Another, and probably much more important cause clinically, was discovered by Meakins, Priestley, and myself during the war. This is irregular distribution of air in the lung alveoli, owing either to shallow breathing or to irregular obstruction of bronchi. The consequence of this is that some alveoli are ventilated to an abnormal extent, while others are very imperfectly ventilated. Now the increased ventilation will remove a correspondingly increased proportion of CO₂ from the blood but cannot substantially increase the blood's charge of oxygen, since with ordinary ventilation the haemoglobin is nearly saturated. The diminished ventilation will correspondingly diminish not only the removal of CO₂ but also the absorption of oxygen. The net result is that the mixed arterial blood becomes insufficiently saturated with oxygen although its charge of CO₂ is no greater than normal. Symptoms of anoxaemia are thus produced. We found that in various forms of neurasthenia or exhaustion affecting the bulbar centres—a very common clinical condition—the depth of breathing becomes reflexly restricted with production of anoxaemia, which in acute attacks may be very severe, particularly in the recumbent position. The exaggeration of this condition in the recumbent position explains the common symptom orthopnoea. This anoxaemia can be identified clearly by the action of oxygen administration. The anoxaemia of pneumonia, bronchitis, emphysema, and ordinary cardiac cases appears to be mainly due to this irregular distribution of air in the lungs, and this accounts for the striking effects of continuous oxygen administration. It might at first sight seem that in ordinary lobar pneumonia, where the greater part of the lungs may be consolidated, arterial anoxaemia must result from a large amount of venous blood passing the lungs without being oxygenated. In reality the circulation in the consolidated parts is almost entirely blocked, as is strikingly shown in x-ray photographs prepared for Professor Meakins of injected lungs in pneumonia, and also by the fact that the arterial anoxaemia and accompanying symptoms disappear with oxygen administration, or as soon as the rapid shallow breathing ceases on the occurrence of the crisis, though the consolidation remains.

Beyond calling attention to the great interest and importance of the recent Edinburgh work, I shall not attempt to go into details on the subject of anoxaemia, particularly as I did so in a somewhat recent lecture published in the BRITISH MEDICAL JOURNAL.⁹ I must also pass over those wonderfully beautiful processes by which the haemoglobin of the red corpuscles assists in regulating both the concentration of free oxygen and the reaction of the blood in the capillaries.

RENAL SECRETION.

I shall now pass to the subject of renal excretion. The renal secretory structures consist essentially of the glomeruli, first part of the convoluted tubules, straight tubules, second part of the convoluted tubules, and collecting tubules. What happens in each of these parts I shall not attempt to discuss. The parts played in them by filtration, active excretion, and active re-absorption are still obscure. What I wish to speak of is the physiology of renal excretion as a whole; and recent investigation has shown that the kidneys, just like the lungs, regulate the composition of the blood, and indirectly of the whole body, with a delicacy of which in former times there was hardly even a suspicion. I have already referred to the extreme delicacy with which the kidneys help to regulate

the reaction of the blood; but this is no isolated phenomenon.

REGULATION OF DIFFUSION PRESSURE OF WATER IN THE BLOOD.

The main constituent of the blood is water. If we drink water by itself when the body is already fully supplied with water, the result is that the water is promptly excreted by the kidneys. If a very large quantity of water is drunk the diuresis is correspondingly great, and the urine excreted is almost pure water, since hardly any more sodium chloride, urea, and other constituents of the blood are excreted than would be normally. Priestley and I carefully observed the concentration of the blood during profuse water diuresis, but could detect no diminution in its haemoglobin percentage.¹⁰ It is thus evident that if there is any blood dilution due to the water, it is extremely small. By the extremely delicate electrical conductivity method, however, Priestley was able to detect a slight diminution in the concentration of salts, with a return to normal as the diuresis ceased. The slight diminution was, perhaps, partly due to passage of salts outwards from the blood into the pure water obtained at first in the gut. This would have the effect of slightly increasing the diffusion pressure of water in the blood, or, to use what seems to me a wrong, though still customary, expression, of slightly diminishing the osmotic pressure of the blood. Dr. E. F. Adolph has recently investigated in my laboratory the regulation of the normal water content of the body.¹¹ By water-starvation it is possible to reduce by several pounds the body weight, in spite of resistance to this by diminished excretion of urine. When water is again taken freely the body weight simply goes up to its normal amount, and when this point is reached any further water taken is promptly excreted. By various other experiments with diuretic substances he has shown how persistently and accurately the water content of the body is regulated by the kidneys during health.

REGULATION OF DIFFUSION PRESSURES OF SOLIDS IN THE BLOOD.

When we turn to the solids excreted by the kidneys we find a similar exact regulation. As Ambard has pointed out, however, we must distinguish between substances of which, as in the case of water, there is a normal threshold concentration or diffusion pressure in the blood, and substances which, so far as is yet known, are actively excreted even to their lowest concentrations in the blood. Urea, ammonia, and sulphates, for instance, seem to have either no threshold concentrations or very low ones. The blood and tissues contain usually about 0.025 per cent. of urea and 0.0005 per cent. of ammonia—about an eightieth of the percentage commonly concentrated into the urine. On the other hand, there are sharply defined normal thresholds for sodium chloride and sugar. When the percentage in the blood rises above these thresholds, even to a very minute extent, excretion by the kidneys begins, and becomes more and more vigorous the more the thresholds are exceeded; but when the percentage falls to the thresholds, excretion practically ceases. Similarly there is an amazingly sharp threshold of blood alkalinity. Below this threshold acid urine is excreted, while above it the urine is alkaline. The dividing line is defined with a delicacy of which physiologists, misled by gross mechanistic conceptions of physiological activity and by the absence of accurate measurements, had no clear conception till quite recently.

When we know what the normal kidney is continuously doing for the body we have the necessary groundwork for discovering what is happening in disease. A kidney disabled for the time by inflammation cannot perform the excretory functions just described, or can only do so feebly. The kidney may, for instance, be lamed as regards regulation of blood alkalinity or excretion of ammonia, with the result that if the diet is an average one, or if no food is taken, acidosis is produced. If the excretion of salts is interfered with and the diet is normally rich in salts, they accumulate in the blood. One result is that the diffusion pressure of water in the body is diminished; hence water, even though the kidneys are still capable of passing it, is retained in the body and dropsy is produced. Another possible result is poisoning due to abnormal proportions of salts or other substances. When we have

"diagnosed" exactly what is happening we can adopt dietetic and other measures to control the evil and tide the patient over till normal processes of recovery have had time to develop. Even though we do not yet know how each part of a normal or disabled kidney is acting, yet, if we can diagnose from the symptoms how the kidney as a whole is failing, we have sufficient data for prescribing rational treatment.

CIRCULATORY REGULATION OF BLOOD COMPOSITION.

Let me now turn to the physiology of the circulation. All that I have already said shows how exactly the composition of the arterial blood is regulated. But in passing round the circulation the composition and temperature of the blood are constantly and very rapidly altering. We may be certain, however, that it is not for nothing that the composition and temperature of the arterial blood are kept so astoundingly steady as they are.

The most rapid and prominent alteration is in the blood's charge of O_2 and CO_2 ; and the change in the colour of the blood as it loses oxygen makes this alteration grossly evident to our vision. I wish now to refer to recent evidence that not only is the composition of the arterial blood accurately regulated, but also the composition of the blood as it leaves the capillaries in the different parts of the body. Physiologists have devoted far too much attention to study of the mere physics of the circulation. What is more important is its physiology—its organic regulation.

Dr. Douglas and I have been engaged for some years in investigations—greatly delayed by the war and its aftermath—on the gases of the mixed venous blood returning to the heart in man.¹² We discovered a method of investigating these gases by determining the composition of the air with which they are in equilibrium when the lungs are artificially filled with such air. The first result of these observations was to show that during complete rest the mixed venous blood is not only very steady as regards its gas content, but is considerably less venous than has hitherto been supposed. The general circulation rate during rest is faster than was formerly calculated. In my own case, for instance, a volume of blood equal to that in the whole body passes through the heart about every thirty-five seconds—about eight litres, or 1.8 gallons, of blood passing in one minute. During muscular exertion the rate is further increased, but in Dr. Douglas and myself only about in proportion to the increase of pulse rate, although the rate of oxygen consumption may be increased eight or ten times. The mixed venous blood becomes, however, far more venous than during rest, so that it may have lost about two-thirds of its oxygen content. From this fact we cannot conclude, however, that in any part of the body the blood becomes at all markedly more venous during work than during rest. It was found many years ago by Leonard Hill, in experiments on animals, that the venous blood from muscles, whether during rest or during work, has lost by far the greater part of its oxygen, but that the venous blood from the brain has lost very little. The oxygen supply to the brain is thus far more free than that to a muscle. During work the blood supply to a muscle must be enormously increased—probably twenty or thirty times—in order to meet the increased consumption of oxygen. Consequently the mixed venous blood contains a far larger proportion of this very venous blood, and this accounts for its being more venous.

A flood of new light has recently been thrown on the regulation of local circulation by the investigations of Krogh of Copenhagen.¹³ It had been shown many years ago by Roy and your president, Dr. Graham Brown, that the capillary walls are contractile. Krogh found by microscopical observation of transparent muscular tissues that during rest nearly all of the capillaries are tightly closed, so that no blood, or even plasma, can pass through them. During activity, however, these closed capillaries relax and become permeable to blood, so that an enormously increased oxygen supply is at once rendered available. We can thus understand how, in spite of the increased oxygen consumption of a working muscle, its oxygen requirements can be met without appreciable lowering of the concentration of free oxygen, or alteration of the reaction, in the local blood supply.

The constancy of the oxygen and CO_2 content of the mixed venous blood during rest has the same significance as the similar constancy of the arterial blood. What it

points to is that the composition of the venous blood leaving particular organs is regulated just as much as that of the arterial blood. In other words, the blood flow is so regulated as to ensure this constancy. In the brain the required concentration of free oxygen is evidently very high, and this accounts for the fact that any failure, even slight, in the aeration of the arterial blood has such serious consequences in producing nervous symptoms. It accounts, also, for the striking anatomical fact that the blood vessels supplying the brain are very large, even though the white matter of the brain may have a relatively low oxygen consumption.

I have not time to discuss in detail how the bulbar centres which regulate the action of the heart and the calibre of the larger blood vessels, as well as the breathing, react directly or indirectly in response to the chemical or thermal stimuli which consist in slight variations in the gaseous and other composition, or temperature, of the blood. Nor have I time to discuss how local blood supply responds to the local chemical stimuli through which organic regulation of the blood composition in every part of the body is maintained. I should like, however, to refer, in conclusion, to certain broad principles which seem to emerge very clearly in connexion with the recent advances which I have been describing.

SIGNIFICANCE OF PHYSIOLOGICAL REGULATION.

First and foremost it seems evident that physiological regulation is not only something very real, but is also extremely delicate. It is only by exact quantitative observations that we can estimate the delicacy of regulation; but symptoms, if we interpret them rightly, give us an extremely sharp index of failure in normal regulation. I need hardly, however, speak to such an assembly as this of the paramount importance of the close observation and right interpretation of symptoms. Regulation to a normal during health implies that the living body actively maintains a normal of structure and activity in spite of ever-changing conditions of environment. From side to side of this normal the living body is constantly oscillating as the result of disturbance in the environment, and constantly tending to return as near as may be to the normal in spite of the disturbance. We can distinguish ordinary physiological disturbances, which the body can easily overcome, from the more serious disturbances which require medical or surgical treatment to assist the return to normal or something approximating to it; but apart from the fundamental assumption that it is, to use the old expression of Hippocrates, the "nature" of a living organism to maintain a normal, and to return towards it in spite of disturbance, physiology and medicine seem to me to be a mere chaos of unconnected empirical observations. It is the reality of organic regulation, and the necessity for the guiding conception of organic regulation, that stand out in the results of the investigations which I have tried to summarize. The aim of physiology, and of every branch of biology, is, as it seems to me, to render clear by experiment and observation what the normal activities and structure of a living organism are, what the deviations from them really consist in, and how the normal tends to be maintained or re-established in face of disturbance.

BIOLOGY NOT BIOPHYSICS AND BIOCHEMISTRY.

Another ideal for biology is to search out the mechanism—the physical and chemical causes—of all biological phenomena. This ideal aims at superseding the Hippocratic conception that it is the "nature" of a living organism to maintain a normal, and it represents biology as simply "biophysics" and "biochemistry." To this conception of biology the objection is that it does not enable us to understand and predict the facts. Why does the respiratory centre fail to react to increase in hydrogen ion concentration until a certain threshold value is reached, and yet react so vigorously as soon as this threshold value is exceeded to the minutest extent? Why do renal excretion and circulation behave in a similar manner? Why do reflexes adapt themselves to varying conditions, as in the case of the respiratory reflexes? Why does the body tend obstinately to maintain in every aspect of its structure and activity a certain normal? And why, from generation to generation, is this structure and activity so accurately reproduced? To these questions the mechanistic conception of life affords no answer. Yet

the phenomena which raise them are the characteristic phenomena of life. It is because of the necessity in any science of having working conceptions which correspond to observation that I must claim for biology her own working conception—that of the living organism as such. This was essentially the claim which Hippocrates was the first to put forward; and to me he appears as the father, not only of scientific medicine, but also of biology in general.

THE GREEK SCIENTIFIC TRADITION IN MEDICINE AND BIOLOGY.

It seems to me that the progress of biological investigation is and has been steadily in the direction of consolidating the Greek scientific conception which has been so closely associated with the development of medicine. The supposed mechanism of life has been steadily eluding our mental vision, while knowledge of organic regulation has been equally steadily advancing, as has been illustrated in this lecture. I have tried elsewhere to show that the mechanistic conception of life is based, not on biological observation, but on metaphysical assumptions for which there is no sound basis.¹ Without going into this controversy, however, I wish to point out that the Greek conception gives us a working hypothesis which knits existing physiological knowledge together in a way that the mechanistic theory is quite incapable of, and which suggests new and fruitful paths of investigation in every direction. It also seems to give us what may be called a working philosophy of practical medicine and surgery. We of the medical profession are not mere chemists and mechanicians. Our business is to understand organic regulation, and where necessary to assist it. We cannot pretend to understand, replace, or repair, a physical and chemical mechanism which is beyond our powers of conception, and which, in my own opinion at least, is simply not there any more than was the traditional black hat in the dark room. What we can do, and do more and more effectively the more we understand of organic regulation and the conditions which disturb it, is to assist in the maintenance or restoration of this regulation.

Is the Nature which we are concerned with nothing but that apparent world of matter and energy which the working conceptions of physics and chemistry present to us? If it is, then organic regulation is only an appearance which will some day be explained in physical and chemical terms. Those who have been carried away by the flood of popular materialism which has been passing over the world in recent times are ready to answer this question in the affirmative and to go back to the search for the black hat in the dark room. Well, I cannot go with them. It seems to me that there are unanswerable reasons for concluding that the black hat is not there, and that the world as interpreted by the physicists and chemists is not the objective or real world, but only an imperfect subjective interpretation of it. The aspect of Nature which Hippocrates saw in the living body, and which a doctor can hardly help seeing in his daily work, is to my mind much nearer to objective reality than the aspect which is depicted by the physical sciences. What I have been trying to show to you this evening is that deeper and truer aspect of Nature which is seen not only in Medicine, but also in every other branch of biological work.

REFERENCES.

- ¹ *Journ. of Physiol.*, xvi, 1915, p. 316. ² Recent communication to Physiological Society. ³ *Journ. of Physiol.*, li, 1920, p. 32. ⁴ Recent communication to Physiological Society. ⁵ *Journ. of Physiol.*, liii, 1919, p. 181. ⁶ *Journ. of Biol. Chem.*, xxviii, 1919, pp. 355, 355. ⁷ *Journ. of Pathol. and Bact.*, xxiv, 1921, p. 73. ⁸ *Journ. of Physiol.*, lii, 1919, p. 455. ⁹ BRITISH MEDICAL JOURNAL, July 19th, 1919, p. 65. ¹⁰ *Journ. of Physiol.*, l, 1916, pp. 296, 304. ¹¹ Recent communication to Physiological Society. ¹² Recent communications to Physiological Society. ¹³ *Journ. of Physiol.*, li, 1919, p. 457. ¹⁴ This matter is discussed in my book *Mechanism of Life and Personality*, second edition, 1921, and *The New Physiol.*, 1919.

A SECOND volume of *Studies in the History and Method of Science*, edited by Dr. Charles Singer, is about to be issued. The first volume appeared in 1917, with a preface by Sir William Osler. The second volume contains articles by Dr. E. T. Whittington, on the Asclepiadæ and the priests of Asclepius; by F. J. Cole, on the history of anatomical injections; by F. C. Conybeare, on four Armenian tracts on the structure of the human body; and by Mr. Arthur Platt on Aristotle on the heart. The editor contributes two articles, the one on Greek biology and its relation to the rise of modern biology, and the other on steps leading to the invention of the first optical apparatus.

PHYSIOLOGICAL PRINCIPLES IN MIDWIFERY PRACTICE.

BY

JOHN S. FAIRBAIRN, M.A., B.M., B.Ch. Oxon.,

F.R.C.P., F.R.C.S.,

OBSTETRIC PHYSICIAN, ST. THOMAS'S HOSPITAL.

THE reproductive cycle in its widest sense—from one generation to the maturity of the next—has somehow never received adequate attention from the physiologist or taken its proper place in the medical curriculum. From the purely biological aspect the only claim to the continuation of a species rests on its ability to perpetuate itself in the struggle with other species; from the medical standpoint, reproduction is as much an integral part of medicine as digestion, respiration, or the circulation. Owing, however, to the way in which medical practice and knowledge has developed, and not on logical grounds, much of what is included under the heading of the reproductive cycle has been separated off from medicine. Eugenics may be left out of account as too largely a sociological matter, but midwifery, in the modern interpretation of the term—that part of the cycle from conception to the care of the nursing mother and nursing—has been separated by practice; pediatrics and the importance of the developing child and adolescent have only recently been thrust into the foreground by a universal quickening of the consciousness of nations as to the necessity for the care of the rising generation. Perhaps as a result of the loss of its proper place in physiology and medicine the early part of the reproductive cycle—the part that counts most—has been later in acquiring the present-day tendency of medicine to study its problems from the point of view of physiology rather than pathology, and I wish to see what this may mean if applied to that portion of the reproductive cycle I have included under the term "midwifery."

I will begin by taking as an instance of what greater attention to physiological processes may do, the change in our practice as regards infant feeding, and afterwards try to apply these lessons to the management of the woman in labour. I do this because this change has influenced my own mental attitude towards labour more than anything else, and may have a like influence on others, and also because it forms an illustration of reformation along physiological lines already accomplished, and thus indicates what may be possible in the case of labour.

Formerly our attention was largely directed towards perfecting substitutes for the natural food of the baby, and great success has been obtained in adapting the milk of another mammal, so as to enable the human infant to thrive on food never intended for it. Our textbooks devoted no more than a line or two to breast-feeding. There was a pious statement that it was best for infant and mother; there was a list of contraindications and instructions as to how to disperse the milk when suckling was not carried out, and that was about all; whereas the preparation of substitutes and the modification of cow's milk and other possibilities took up pages, and even chapters, so that there is little wonder that the student, when he had blossomed out into a practitioner, was entirely ignorant of the physiology of lactation and the management of breast-feeding. No attention was given to the causes of failure to suckle and how they might be removed, or to the means of increasing mammary activity when inefficient, or to the investigation of the reasons why the baby did not thrive satisfactorily at the breast. I am indebted to Dr. Truby King—and many others with me—and to what is accomplished at the School of Mothercraft, of which he was Director during his stay in this country, for an entirely fresh idea of the possibilities of breast-feeding in difficult cases.

At any time in the school at Trebovir Road living evidence of what a few years ago would have been thought impossible may be seen in the shape of mothers who have failed in previous confinements, and mothers whose infants have been weaned for six weeks or more, successfully nursing a contented baby. The error was that our energies had been devoted to providing a substitute for the function we did not attempt to control. We were clearly on wrong

lines, for, however successful, such substitutes could never be as good as the real thing. We should rather have studied the function of lactation and how to improve it when defective—precisely what we are now learning to do.

I would apply this lesson to the management of labour in cases of deficient uterine action, for the analogy is a close one. Our attitude up to now has been largely that of perfecting the substitute for the maternal powers—namely, the brawniness of the attendant exerted through the midwifery forceps—and, as in the case of artificial feeding, we have attained great success, but also along wrong lines. If there is delay owing to deficient uterine action, the one idea of the attendant is to finish off the labour by instruments, just as the one idea in deficient mammary activity was to be off with the natural feeding and on with the artificial. Suppose, therefore, we adopt the same attitude towards parturition that we have adopted towards lactation, what will it mean?

It will mean a closer study of the normal functioning of the uterus, the factors that hinder it, and of how, by the removal of such factors, the natural powers can be made effective. We will first concentrate on eliminating the indications for the artificial termination of labour and reserve the forceps for those cases in which we fail to secure natural labour. It is no more than following the same line of thought towards management of sluggish uterine action, as towards sluggish intestinal action.

Putting aside cases of complicated labour and those in which some obstructive element is present, and confining our attention to simple delay, there are certain causes which can be readily detected and remedied, such as distension of the bowel or bladder, uterine obliquity, especially that associated with pendulous abdomen, and others, such as over-distension of the uterus and early rupture of the membranes, which may be easily recognized, but not so easily remedied, as there may be other complicating factors. The conditions chiefly contributing to failure of good uterine function in cases of otherwise normal labour may be grouped under the two headings of emotion and fatigue, and I would argue that it is their prevalence, particularly among the more leisured classes, that leads to the frequency of the artificial termination of labour, and I would therefore direct attention chiefly to a consideration of how these conditions can be removed.

Taking the emotional factor to begin with, it is likely to be operative in nervous, highly-strung women, particularly in their first labour. It will be increased by dread of the unknown, by what they have heard of the trials of their acquaintances in childbirth, by the constant suggestion of the necessity of artificial aid, by such circumstances as sympathetic mothers, husbands, and friends, and the concentration of their household on the event in which they, as patients, are playing the principal part. If, as so often happens, the anticipated date is past, they may have had several disturbed nights thinking about, and looking for, the expected pains that are to usher in their time of trial. Perhaps, also, there may be domestic and other worries to add to their mental distress. Thus the frame of mind in which labour begins is often highly unfavourable to physiological parturition, and is then aggravated by the wrong type of nurse and by the arrival of the medical attendant with a bottle of chloroform and a bag of clinking instruments, with their strong suggestion of a speedy ending without further effort.

The other factor, fatigue, requires perhaps even more management, for the uterus of an exhausted woman will not function efficiently. Loss of sleep, want of food, and, most of all, the fatigue that comes of long-continued pain, are among the common causes producing exhaustion.

The practical question is how far we can expect to make labour more natural by our endeavours to remove these causes of uterine inefficiency, and in regard to this I can only give suggestions, for the subject is too wide, and my intention is rather to indicate the lines of approach to the problem than to go into details.

In the first place, the study of the individual patient and an attempt to understand her temperament and attitude of mind towards labour is obviously important. The antenatal care and observation should not be such as to increase her fears and anxieties, but should rather be directed towards reassuring her and impressing her with the idea that she is a normal woman capable of bearing her child naturally. In the case of a woman in her first pregnancy

some time spent in discussing the course of labour, what is to be expected and what she can do to help herself, will not be wasted, and, should she consider herself above the usual age for a first baby and, as is often the case, have special fears, an endeavour should be made to reassure her. The choice of a nurse, too, is a matter of extreme importance; the ideal nurse is hard to find, but if discovered, is beyond price. The talkative and ignorant creature who scares her patients with stories of what has happened to other unfortunate mothers on whom she has been inflicted, or the nervous woman who is easily worried by any incident she thinks may indicate something abnormal, are especially to be avoided. Lack of confidence and over-anxiety are at once reflected in the patient, and a nervous nurse makes a nervous patient. The quiet, understanding woman who recognizes where her patient requires help, and gives a feeling of strength and confidence, will have many more cases of natural labour than the over-anxious and fussy type.

When it comes to the labour itself the advantage of institution management over home delivery is readily seen, and forms an additional argument to that advanced by Mr. Bonney in his paper on "The continued high maternal mortality of child-bearing," on account of its better provision for surgical technique, in that it avoids also many domestic annoyances and the presence of well-meaning but unneeded relations. In the conduct of the labour the object of the medical attendant should be rather that of supervision, and of a supervision that is kept as much in the background as possible. Satisfied that everything is normal, all that can must be done to suggest that the patient's powers will suffice, and that no active interference will be required. The less he is with the patient the better. But she must not be allowed to become played out. Should she bear pain badly, become restless, and lose self-control, relief must be obtained by means of morphine, or morphine and hyoscine, or other sedative, and to my mind, the great art in the management of labour is the knowledge of how and when to give relief to the exhaustion of the uterine pain. Every practitioner may have his favourite method—twilight sleep, so called, the old-fashioned opium or chloral and bromide—but everyone engaged in midwifery practice must study his patient and by careful observation watch for the indications of fatigue and endeavour to prevent its onset. The morphine-hyoscine narcosis has this great merit, that it greatly diminishes the emotional and fatigue effects, and though it may be argued that labour in which the patient is doped with toxic drugs is less physiological than one without drugs terminated by forceps, sedative drugs are too valuable under present conditions to be dismissed in this way. All drugs that have a sedative effect also interfere to some degree with the reflexes and with physiological action, and the problem, as it appears to me at the present time, is to decide how far the obvious disadvantages of their administration compensate for their equally obvious merits.

As a rough generalization I would advocate that preference be given to artificial delivery by the forceps when the failure of the natural powers is only the overcoming of the final obstacle, the muscular resistance at the vulval outlet; and, on the other hand, to place reliance on sedative treatment when deficiency in the expulsive powers is shown when the head is still some distance above the outlet. With increasing knowledge and experience of conducting labour on physiological lines there will gradually come fewer cases of failure to effect the final expulsion.

Returning to the analogy of successful breast-feeding, we cannot but be impressed by the importance of the "atmosphere" of the institution in which it is conducted and think how a like success might be attained in parturition. In the School for Mothercraft, for instance, the anxious mother, distraught by the care of an ailing baby, comes into an atmosphere of assured success with every suggestion of failure removed. The other patients are themselves a factor in her treatment; she hears of more obstinate cases than hers, and sees well-doing infants that were in a worse plight than hers, and the whole ritual impresses her as arranged to spell success. She, in hopes of a cure, is sent for her exercise in the open air with the woman who has been successful beyond her dreams and expatiates thereon. The sisters and nurses, full of confidence in the methods, impart a like confidence to the patients, and half the battle and more is won by the spirit

of the place. It is so striking that one feels that a similar "atmosphere" in the maternity home would also be victoriously gained. The patients would be carefully supervised during pregnancy, so that all cases likely to have obstructive or other abnormalities were kept apart, and the place labelled as a home or hostel for natural labour, and not called a hospital. The midwives and nurses, carefully chosen and inspired with the spirit of the place to see their patients through a natural labour, would be on their mettle to make the methods a success, and would provide the proper atmosphere in which all suggestion of failure is abolished. The medical supervision would be kept in the background, and care would only be required to see that the methods were not carried to the extreme of refusing to recognize failure and postponing forceps delivery to the detriment of mother and infant.

A scheme of this sort is merely applying lessons learnt elsewhere in medicine. It is Dr. Hurst's method at the Seale Hayne Hospital for shell shock and war neuroasthenia. The man struck dumb comes to be cured into a place where the chattering patient in the next bed was dumber than ever he was, and was miraculously restored to speech, as he will be, and so is the cure wrought.

This brings us to the final consideration as to what the future of medical practice in regard to maternity work will be, and, without wishing to attempt the dangerous art of prophesy, I would indicate merely possible changes. The duty of the doctor will be, much more than in the past, the supervision and "vetting" of pregnant women, and the picking out for special management of cases where trouble is likely. The ordinary cases will more and more be left to the charge of trained midwives, medical attention being required rather for unforeseen complications, for the prevention of fatigue, and for delivery in protracted cases. I suggest that once the primary object of the medical attendant is recognized to be the securing of a normal labour, his attendance in the lying-in room is not essential, and, at any rate, need only be occasional—when summoned by the midwife, or for visits of supervision. This is necessary to avoid the strong suggestion of artificial interference which his attendance means, and because among women delivered by midwives the percentage of instrumental deliveries is low, and the reverse for those attended by doctors. I would hope that every practitioner in family practice would have a list of competent midwives, who would be reserved for the duty of attendance on labour, and not merely employed as monthly nurses, and would carry out his methods in the spirit as well as the letter.

It is perhaps rather much to hope for in this world of erring mortals, but it is something to look forward to, and when one notes the reluctance of medical practitioners to take midwifery cases, and sees advertisements of practices made attractive by the announcement that there is little or no midwifery, and recognizes at the same time the primary importance to the nation of the maternity service, the advantage of securing the best medical supervision without taking up too much time and service in attendance on normal labour seems only possible if most of that attendance be given by trained midwives. This involves rather a shifting of the medical service from the part where least essential to those parts where it is most essential: the observation of pregnancy, the study of the individual characteristics of the woman, and the determination of the best methods of management; supervising her labour merely so far as to be assured of the absence of complications, and deciding what is advisable to maintain good uterine action and to avoid fatigue, and generally being ready to answer the summons of his midwife and to act on her reports; after the labour to give much more attention to the puerperium, to lactation, and the young infant, than has been the case in the past. Doubtless the public will have a big say in any change of method, but hitherto the medical services for maternity work have never been paid for adequately, and their shortcomings are, to my mind, largely ascribable to that fact. The public has expected an expenditure of time and skill for fees that are by no means equivalent, and the tendency of the profession has been to cut the loss by shortening the duration of the labour artificially.

Perhaps these speculations as to the lines on which the maternity service will develop are wide of the mark, but I feel sure that they will tend to approach nearer to physiology, and not away from it.

THE TREATMENT OF SYPHILIS.*

BY

HENRY McCORMAC, C.B.E., M.D., F.R.C.P.

URLOGIAN FOR DISEASES OF THE SKIN, MIDDLESEX HOSPITAL,

AND

E. L. KENNAWAY, D.M., D.Sc.

CHEMICAL PATHOLOGIST, BLAND-SUTTON INSTITUTION OF PATHOLOGY, MIDDLESEX HOSPITAL.

The records we publish are the results of some investigations carried out by us in an attempt to gain more definite knowledge of the exact manner in which salvarsan—or one of its substitutes—acts in syphilis. To attain this end we have taken samples of blood before each weekly injection, a method which has afforded us a number of facts from which we have drawn certain conclusions.

It is common knowledge that when salvarsan was first introduced it was thought that one injection would cure syphilis. Further experience soon showed that several injections were required and that mercury should also be given. Such is the position to-day, but although potent arsenical drugs have been in common use for ten years, there is no general agreement as to what amounts of these remedies should be employed or over what time the treatment should be continued.

Curiously enough the first patient treated with salvarsan in the skin department of Middlesex Hospital in 1910 was cured by one injection of 0.6 gram of the original preparation, although the form of malignant syphilis from which he suffered had resisted all other remedies. As he was kept under observation for four years the belief in the reality of his cure seems justified. But such a result is unique in our experience. Indeed, considerable amounts of an arsenical compound and mercury may be given and yet failure result. These failures have tended to throw some doubt upon the efficacy of this form of treatment; but one must bear in mind that failure may be due not only to a defect in a remedy, but also to the manner in which an effective remedy is used.

TABLE I.—Cases of Secondary Syphilis.

No.	Intravenous N.A.B. (No. of Injections).	Total Amount (Grams).	No. of Mercury Injections, each 1 Grain.	Wassermann Reaction.
No. 65 ...	6	2.7	17	Positive 13 months after end of course.
No. 68 ...	7	3.75	24	Positive 7 months after end of course.
No. 144 ...	12	10.2	13	Positive after 6 months.
No. 164 ...	10	6.0	14	Positive at end of course.
No. 190 ..	6	3.6	24	Positive after 1 year.
No. 32:				
Course 1	6	3.4	32	suspicious at end of course.
Course 2	6	5.4	29	Two months after this negative; 6 months later positive.

* Directly after Course 1, because of suspicious Wassermann reaction.

In Table I six such cases are shown. It should be noted that all were in the secondary stage—a peculiarly favourable period; that considerable amounts of novarsenobenzol and mercury had been given; and that in every case the Wassermann reaction ultimately became positive. In No. 32 actually two separate courses were undertaken. To save repetition it may be stated here that the arsenical preparation used in all cases reported in this paper was novarsenobenzol Billon (N.A.B.) administered by the intravenous route.

This type of treatment is thus open to criticism—although it is a form commonly followed—and should be replaced by some other. Either larger doses of N.A.B. should be used, or more numerous injections given, or both. These questions received consideration when Dr. Pringle took charge of the department in 1917, and he formulated a scheme which has been adopted. It is as follows: ten intravenous injections of N.A.B. are given at

An address to the Essex Branch of the British Medical Association on September 21st, 1920.

intervals of a week, the first of 0.6 gram, the remaining nine of 0.9 gram—in all 8.7 grams. With each an intramuscular injection of mercury is also given. While these doses may appear large they have but rarely been found excessive, and as they have now been used in a large number of cases, sufficient experience to form a judgement has been obtained. There are cases, but such are exceptional, where some modification is desirable, the reasons for which need not be particularized as they will be evident to any practitioner.

The results of such a series of injections on the Wassermann test from week to week is shown in the following tables (II, III and V), arranged in accordance with the stage of disease, primary, secondary, or tertiary. All cases shown in these series were males, as it is easier to obtain weekly samples of blood from them.

TABLE II.—Cases of Primary Syphilis.

Reference Number.	Spirochaetes.	COURSE WITH MERCURY—WEEKS:											
		1	2	3	4	5	6	7	8	9	10	11	12
904		++	++	++	±	++	+	o	o	±	-	-	-
956	Not found	++	++	+	+	-	-	-	-	-	-	-	-
998		++	o	++	++	A	+	o	A	-	A	A	-
1059	Present	++	++	++	++	o	++	o	o	+	-	-	-
922	Present	-	++	±	±	±	-	-	-	-	-	-	-
913		-	±	-	-	-	-	o	A	-	-	-	-
908	Present	-	o	-	±	-	-	-	-	-	-	-	-
981		-	o	++	o	+	-	-	-	-	-	-	-
1060	Present	-	-	-	-	o	-	o	-	-	-	-	-
1034	Present	-	-	-	-	-	A	-	-	-	-	-	-
		COURSE WITHOUT MERCURY.											
1061		++	++	++	o	++	o	++	+	-	-	-	-
1079		++	++	++	+	-	-	-	-	-	A	-	-
1070	Not found	-	++	o	-	-	o	o	A	-	-	-	-
1124	Not found	-	++	-	-	-	-	-	-	-	-	-	-
1133		-	+	±	-	-	-	-	-	-	-	-	-

The symbols used in this table and in Tables III and V are to be interpreted as follows:

- ++ = Wassermann reaction strongly positive.
- + = Wassermann reaction weakly positive.
- ± = Wassermann reaction suspicious.
- = Wassermann reaction negative.
- A = Absent from treatment.
- o = No sample of blood taken.

It is evident that the use of mercury simultaneously with the N.A.B. introduces a confusing element; we have therefore included a second series where no mercury was given during the ten injections, in order to obtain clearer evidence of the results of the salvarsan injections alone.

Examination of the above table shows, as is well known, that in primary syphilis the Wassermann reaction may be positive or negative. But it shows a further and important fact, that in the 9 cases where it was negative to begin with, in 7 of these it became positive or suspicious, although the patient was under treatment. Had not the weekly test been made, this would have escaped observation.

It is, of course, well known that the excision of the chancre does not prevent the subsequent progress of disease in untreated primary syphilis, but our investigations represent a different aspect of the problem. It has been held by many that, if treatment be immediately instituted in primary syphilis while the Wassermann reaction is negative, this prevents the development of a positive phase, and on this assumption it has been concluded that primary syphilis with negative Wassermann reaction is a much more favourable state than primary syphilis with positive reaction. The investigation of the disease week by week shows that despite treatment a positive reaction develops, therefore no distinction should be made between the two classes. Indeed, in two cases where the initial reaction was negative, the subsequent positive phase was discovered to persist longer than in a case where the initial reaction was positive—for example, 922 and 981, as compared with 956. It has been suggested by

a critic that some of the reactions correspond to a provocative response. These are, however, not cases of latent but of active syphilis, and therefore it would seem more correct to regard this appearance of a positive Wassermann reaction as evidence of progress of the disease.

There is a further point to which attention should be directed: in no case can the response to treatment be foretold from the type of chancre. Thus cases No. 1,059 and No. 1,060 were identical as regards date of infection and type of sore, and yet the reaction to treatment was completely different. Conversely, different types react as regards the Wassermann reaction in the same manner.

A comparison of the series treated with N.A.B. plus mercury with those treated by N.A.B. alone shows no marked difference. In the former, in two cases a negative response did not appear before the tenth week (904 and 1,059); in the latter the longest positive phase is represented by 1,061, the reaction remaining positive until the eighth week. The number of cases is not sufficiently large to admit of any dogmatic assertion, but so far as they go they show no distinct advantage in one method over the other.

The condition of the blood has been ascertained in six primary cases at periods of from six to eight months after commencement of treatment; all were negative.

TABLE III.—Cases of Secondary Syphilis.

Reference Number.	COURSE WITH MERCURY—WEEKS:															
	1	2	3	4	5	6	7	8	9	10	11	12	13	14	15	
777	++	++	+	++++	+	-	-	±	A	A	+	+				
793	++	++	++	++++	+	±	-	-	-	-	-	-	-	-	-	
794	++	++	++	++++	+	A	+++	++	+	-	A	++	+	+	+	
829	++	++	++	++++	++	A	±	±	-	-	-	-	-	-	-	
831	++	++	+	-	-	A	-	-	A	-	-	-	-	-	-	
833	++	A	A	++++	A	+++	++	++	++	A	++	±	-	-	-	
837	++	++	++	++++	++	++	±	-	+	-	-	-	-	-	-	
838	++	++	++	±	++	±	-	-	-	-	-	-	-	-	-	
856	++	o	A	++++	o	++	±	A	+	A	-	A	±	±	±	
1019	++	++	++	++	+	-	A	A	A	A	A	-	-	-	-	
854	-	o	++	±	-	-	-	-	-	-	-	-	-	-	-	
900	++	++	++	++	A	++	++	±	-	-	-	-	-	-	-	
959	++	++	++	o	++	++	±	-	-	-	-	-	-	-	-	
986	++	++	++	++++	++	±	±	±	-	-	-	-	-	-	-	
982	++	+	-	++	+	-	-	-	-	-	-	-	-	-	-	
992	++	++	A	++++	+++	±	-	-	-	-	-	-	-	-	-	
996	±	-	-	-	-	-	A	-	-	-	-	-	-	-	-	
1009	++	++	++	++++	++	±	-	-	-	-	-	-	-	-	-	
1024	++	++	+	±	-	-	-	o	-	-	-	-	-	-	-	
		COURSE WITHOUT MERCURY.														
1048	++	++	++	++++	++	o	++	-	-	-	-	-	-	-	-	
1067	++	o	++	++++	+	o	A	-	-	-	-	-	-	-	-	
1083	++	++	++	++++	++	+	+	A	-	-	-	-	-	-	-	
1087	++	++	++	++++	++	++	++	++	++	+	±	-	-	-	-	
1113	++	o	o	++	o	++	++	++	++	++	++	-	-	-	-	
1135	++	++	++	++++	++	++	++	++	++	++	-	-	-	-	-	
1148	++	++	o	o	o	-	-	-	-	-	-	-	-	-	-	
1119	++	++	++	++++	++	A	++	-	±	-	5	-	-	-	-	
1116	++	++	++	++++	++	+	A	-	-	A	A	-	-	-	-	
1157	++	++	++	+	-	-	-	-	-	-	-	-	-	-	-	

1 Wassermann reaction negative six months later.

2 Wassermann reaction negative eight months later.

3 Patient ceased to attend.

4 Patient absent for eight weeks at this stage.

5 Treatment with N.A.B. discontinued as precautionary measure in consequence of slight erythema.

Table III is compiled in a manner similar to Table II, but here all the cases represent the secondary stage. As in the previous group two series are included, one where mercury and N.A.B. were combined, and a second where

N.A.B. alone was given. A favourable response to treatment is still found. In three cases 12 injections were given, in one 11, in one 9, in one 8, and in two 7; the remainder received 10 injections. No. 831 is an example of severe and extensive involvement of skin and throat, where the negative reaction appeared after the third injection. Thus in the secondary, as in the primary phase, the clinical manifestations alone furnish no information as to the rate of progress under treatment as judged by the change in the Wassermann reaction.

A more general examination of this table shows that a favourable response occurs somewhat earlier in the first series. The actual findings are brought together in Table IV, which indicates that there is some slight advantage in the plan of administering mercury and salvarsan together.

TABLE IV.—Effect of Treatment in Cases of Secondary Syphilis.

In patients who received treatment by Arsenic and Mercury the Wassermann reaction first become negative as follows:

After 1 injection in ...	1 case
" 3 injections in ...	2 cases
" 4 " " " ...	2 "
" 5 " " " ...	1 case
" 6 " " " ...	3 cases
" 7 " " " ...	3 "
" 8 " " " ...	4 "
" 9 " " " ...	1 case
" 10 " " " ...	1 "

18

In patients treated by Arsenic only the Wassermann reaction first became negative as follows:

After 4 injections in ...	1 case
" 5 " " " ...	1 "
" 6 " " " ...	1 "
" 7 " " " ...	3 cases
" 8 " " " ...	1 case
" 9 " " " ...	1 "
" 11 " " " ...	2 cases

10

As compared with primary cases the negative reaction appears more slowly, but is still obtained. In Case No. 854 the Wassermann reaction was found to be negative at first, although a well-marked skin eruption was present. One other case, No. 829, demands comment. This is an example of a second infection occurring while the patient was still under treatment for a previous infection. He first came under our observation with a chancre on the abdomen and his progress during the series of N.A.B. injections is indicated in the table. Subsequent treatment with mercury was continued for one year when he again developed a chancre, this time on the penis. That this was not a relapse is shown by the following facts: The first chancre was upon the abdomen, the second on the penis, and there was a history of exposure four weeks prior to its appearance. Abundant spirochaetes were present in the second chancre. The Wassermann reaction was negative at periods of six and nine months after the first infection. It is interesting to observe that this man had remained under treatment up to the time of his second attack, and thus acquired syphilis while saturated with mercury, and that his Wassermann reaction became positive shortly after the appearance of the second chancre. It is impossible to say whether he would have developed secondary manifestations or not, as he was put under further treatment with N.A.B. immediately.

From the facts appearing in Table III certain deductions may be drawn. It is evident that an "intensive" course limited to six injections, especially where smaller doses are used, may be insufficient. Further evidence of this is found in the number of cases so treated coming to hospital with clinical or serum relapse. Five such cases are included among the above series. There would appear, on the other hand, to be good reason for adopting the "ten" series, provided the beneficial effect is maintained by continued mercurial treatment, the nature of which will be described later. This belief is confirmed by the subsequent behaviour of the secondary infections. Investigation was made in fourteen cases at periods of from six to twelve months after commencement of treatment; all were negative. In twenty other secondary cases treated in a similar fashion, nineteen were negative and one suspicious after six months. Such

evidence does not prove cure, but it demonstrates that a process of curing is taking place.

TABLE V.—Cases of "Tertiary" Syphilis.

Duration of Disease.	Reference Number.	COURSE WITH MERCURY—WEEKS:													
		1	2	3	4	5	6	7	8	9	10				
Leucoplakia 20 years	796	+	+	+	+	o	+	+	+	+	+	+	+	+	A
Tabes 10 years	801	+	+	o	+	—	—	+	—	±	+	+	+	+	+
18 years	802	+	+	+	+	+	+	+	+	+	+	+	+	+	+
3 years	828	+	+	+	+	+	+	+	+	+	+	+	+	+	+
8 years	853	+	+	+	+	+	+	+	+	+	A	+	+	+	+
20 years	872	+	+	o	+	+	+	+	+	+	+	+	+	+	+
9 years	925	+	+	+	+	+	+	+	+	+	+	+	+	+	+
30 years	905	—	o	—	—	o	—	—	—	—	—	—	—	—	—
Congenital	936	—	o	—	—	—	—	A	—	—	—	—	—	—	—
Tabes 15 years	954	—	—	—	—	—	—	—	—	—	—	—	—	—	—
22 years	969	+	+	+	+	+	+	+	+	+	+	+	+	+	+
7 years	1020	+	+	+	+	+	+	+	+	+	+	+	+	+	+
Congenital	1028	—	±	—	—	—	—	—	—	—	—	—	—	—	—

COURSE WITHOUT MERCURY.													
Duration of Disease.	Reference Number.	1	2	3	4	5	6	7	8	9	10		
7 years	1049	+	+	+	+	+	+	+	+	+	A	+	
32 years	1047	+	+	+	+	+	+	+	+	+	+	+	
Leucoplakia 20 years	1064	+	+	+	+	+	+	+	+	+	+	o	
Gummata 10 years	1093	+	+	+	+	+	+	+	+	+	+	A	+
Tabes	1094	+	+	+	+	+	+	+	+	+	+	+	+
Perforating ulcer 30 years	1118	+	+	+	+	+	+	+	+	+	+	+	+
Tabes	1121	—	—	—	—	—	—	—	—	—	—	—	—
20 years	1123	+	+	+	+	+	+	+	+	+	+	+	+

Before beginning a consideration of the series of tertiary cases we should explain that we employ this term—admittedly an unsatisfactory one—because it is useful as expressing a syphilitic state of some years' duration; it denotes the hypersensitive period. As in the tables of primary and secondary disease, two separate series are included. It is, however, unnecessary to consider them apart.

The characteristic feature of this series of cases is the unaltered state of the blood reaction. The initial positive or negative remains constant throughout. In every case shown in the table some active syphilitic manifestation existed. Thus, in No. 936, a man aged 34, interstitial keratitis and gummata of both legs were present; while the Wassermann reaction remained negative, the gummata healed rapidly under treatment. One other case may be noticed; in No. 801 a temporary negative phase occurred about the middle of the course of N.A.B. injections. Before coming under our care this man had received five injections, which may account for the unusual finding.

We have ascertained the later results in 10 cases. At periods of seven to nine months the Wassermann reaction was still positive despite the ten injections of N.A.B. and the further use of mercury up to the time the test was made.

The following general conclusion may be drawn in respect to old-standing disease. Although the symptoms which the patient presents may be relieved, treatment fails to influence the Wassermann reaction permanently. It is true that by prolonging the treatment over several years a negative Wassermann reaction may be sometimes brought about; but in our experience such an effect is not lasting.

GENERAL OBSERVATIONS.

Although it is not strictly within the scope of this paper, treatment is so intimately connected with diagnosis that some reference to the interpretation of the Wassermann reaction may not be untoward. It is becoming more and more common for patients to be referred by practitioners, or to come voluntarily, for a "blood test." Even the evidence of a single negative Wassermann reaction is sometimes accepted as conclusive. But the Wassermann

reaction is only one of the factors upon which diagnosis should be based. In all forms of syphilis, including the secondary, a negative Wassermann reaction may be met with. Nor is there anything in the nature of syphilis to prevent the person infected with it and having a positive Wassermann reaction from developing some other disorder—for example, psoriasis or scabies. Hence, if the syphilitic nature of any lesion of the skin or elsewhere be concluded or excluded solely on the result of a "blood test" many mistakes will be made. This consideration is not purely academic. Examples of error arising in this way have frequently come under our observation. Nor should the statement that treatment has an effect on the Wassermann reaction be allowed to pass unchallenged. Treatment has an effect upon the disease, and this is shown in the primary and secondary stages by the changing character of the reaction. In the later stages, on the other hand, treatment may alleviate or remove symptoms, but in the great majority of cases it does not cure the disease, and therefore fails to influence the reaction. These statements are borne out by the findings in the foregoing tables.

What is the meaning of such persistent positive Wassermann reactions? Are they merely the result of some habit of the tissues acquired as the result of previous infection? We believe this is not the case, but that they indicate the presence of spirochaetes. The best evidence for this belief is obtained from consideration of gummatous conditions of the skin. We know that treatment causes gummata to disappear, but we also know that the chance of subsequent relapse is considerable. But gummata are the consequence of local spirochaetosis. Here, then, the persistent Wassermann reaction is clearly associated with the continued presence of spirochaetes. In the case of disease of the skin the evidence is more obvious, because we can actually observe what happens, but consideration of facts goes to show that the above statement is equally applicable to old-standing disease of other parts of the body. The spirochaetes have acquired some property enabling them to withstand remedies capable of destroying them at an earlier period of infection. This indifference of chronic infection to remedy is common to infective processes in general, and in this syphilis only obeys a recognized pathological law.

Syphilis is but one process, whether it involve skin, mucous membrane, nerve, or other tissue, and the phenomena which go to make different diseases are largely the result of mechanical interference with function. The principles upon which treatment is based vary in accordance with the duration of infection. When infection is recent—that is, in primary and secondary syphilis—two objects are in view: cure of disease and prevention of communication to others, for at this period the disease is contagious. Therefore a severe and lengthy course of treatment should be undertaken. On the other hand, in old-standing disease only symptoms are treated, because the disease is now very difficult to cure and is no longer communicable. Therefore the form of treatment may be shorter, and repeated from time to time as circumstances demand.

In forming a comparative estimate of the value of salvarsan and mercury certain considerations should be borne in mind. In the early stages salvarsan should be used to bring the disease within the scope of mercury, which finishes the cure. Salvarsan rapidly brings about the negative phase, which is maintained by mercury. This may be interpreted as follows: Salvarsan destroys the majority of, sometimes all, the spirochaetes, and mercury kills any which may have chanced to escape. But the amount of salvarsan must be adequate. As is shown in Table III, six injections are often insufficient. Nor are small doses satisfactory; not only is the favourable effect on the Wassermann reaction often wanting under their use, but when they are employed the clinical manifestations after a period of improvement may become active again, even under treatment. The "ten" series seems largely free from these objections, and although lesser amounts have succeeded in many cases, the standard of treatment should depend upon what the average, not the favourable exception, requires.

In primary and secondary stages, then, treatment should commence with the series of ten intravenous injections of N.A.B. already outlined. There appears to be an advantage in giving mercury at the same time, but the evidence in favour of this is not conclusive (see Table IV). On the

other hand, if mercury be withheld during the period of arsenical medication, opportunity is afforded for improving the condition of the teeth and mouth and thereby diminishing the chance of subsequent mercurial gingivitis, a point of practical importance, since such an occurrence may seriously interfere with subsequent treatment.

When the salvarsan course is concluded mercury is administered by the intramuscular route for three months. The condition of the Wassermann reaction is then determined. If positive, the course is repeated from the beginning. If negative, mercury, either in the form of injections or pills, is continued until two years have been completed from the commencement of treatment with suitable rests, the Wassermann reaction being investigated every three months.

Such a course is doubtless severe and prolonged. But with ordinary care and modification, if any condition demanding this arise, it can be carried out without harming or even inconveniencing the patient. When the serious results of failure are put in the balance against it, it would appear to be entirely justified. Nor should the consequence of delaying cure be forgotten. As time passes the disease becomes more fixed; therefore, if failure result from any form of treatment, the time that has passed in carrying this out may have allowed the disease to merge into an incurable state.

In the late stages in our series ten intravenous injections of N.A.B. and then three months' intramuscular mercury were given. What may subsequently be done depends upon the clinical progress of the case. In this connexion it should be remembered that in disease of the nervous system there is often a considerable latent period, up to three or four months, before improvement becomes evident. Repetition of this course is generally necessary, and this would be expected from what has already been said in reference to the Wassermann reaction.

Finally it may be added, that even in late stages of the disease active forms of medication, such as salvarsan or mercury by inunction or injection, are preferable to other methods.

SUPRAPUBIC DRAINAGE OF THE BLADDER:

THE DE PEZZER TUBE.

BY

G. S. MOTHERSILL, AND CLIFFORD MORSON,

M.D., C.M.McGILL.

O.B.E., F.R.C.S.

ST. PETER'S HOSPITAL FOR URINARY DISEASES.

For a considerable period acute retention of urine has been relieved by puncturing the bladder with trocar and cannula. More recently a number of operations have been devised to facilitate suprapubic drainage and prevent any leakage into the pre-vesical space or upon the external abdominal wall. In certain suitable cases the insertion of the self-retaining tube invented by M. De Pezzer fulfils its purpose of draining the bladder from above the pubes without leakage or discomfort.

The bladder should be distended with at least 16 oz. of boric lotion at body temperature. An incision of about three-quarters of an inch is made just above the pubes. The sheath of the rectus is then cut; with the tip of the finger the fibres are separated and the bladder wall felt beneath. A trocar and cannula, the latter fitting a No. 28 De Pezzer tube, are then plunged through the bladder wall. The trocar is removed; the tube, guided by a stylette, is passed through the cannula into the bladder. The cannula is withdrawn and then the stylette, leaving the tube in the bladder. The end of the tube is mushroom-shaped and plugs the orifice securely, automatically flattening out with the rise of urine; moreover, the hole in the bladder is exactly equal to the size of tube, so that leakage is impossible.

After the wound has healed, usually about forty-eight hours later, a wooden stopper is inserted into the distal end of the tube and the patient is able to walk about in comfort without fear of wetting his clothes. A rubber garter round the thigh holds the tube in position. So simple and practical is this device that when the patient desires to micturate he can slip the tube from under the garter and remove the wooden stopper, thus relieving nature by the artificial means as easily as by the natural.

In order to keep the urine sweet and the tube free from mucus and phosphates, the patient should be provided with a glass syringe and instructed to wash out the bladder morning and evening with pot. permang. 1 in 8,000. Acid sodium phosphate gr. xv xxx four times daily should be given to keep the urine acid.

The tube should be removed about once a month and replaced by a new one. This is easily done with a stilette, which straightens out the proximal end, so that it can be inserted into the bladder.

This method of drainage can only be adopted when a good distension is to be obtained and no previous operation has been performed on the bladder; under such conditions there is no danger of wounding the peritoneum when handling the trocar and cannula. Haemorrhage from the bladder wall need not be feared owing to the pressure of the tube.

When haematuria is present the operation is contra-indicated because the De Pezzer tube is readily blocked by clots.

The operation is most successfully used for cases requiring suprapubic drainage of the bladder owing to deficient excretion of urea, prior to prostatectomy. As local anaesthesia is usually sufficient, the patient undergoes a minimum of shock. Well does the urologist know that the shock of a preliminary cystostomy in cases of threatened renal failure in consequence of an enlargement of the prostate will often cause death. So simple a procedure as the insertion of the De Pezzer tube reduces the shock, and, should the kidneys recover their full function, it permits the removal of the prostate without the difficulty caused by the scarring of the abdominal wall.

In cases of carcinoma of the prostate patients find the utmost relief from this method of bladder drainage; they carry on their work and experience no discomfort apart from washing out their bladders.

ANTIMONY IN LEPROSY.

BY

F. G. CAWSTON, M.D. CANTAB.,

DURBAN, NATAL.

THE beneficial effects of various preparations of antimony in the treatment of lepers show that they are not confined to the colloidal preparations of the drug. I have recently had the opportunity of seeing a number of leper patients who have been treated with intravenous injections of a 2 per cent. solution of tartar emetic, whilst others have received the antimony in the form of antimonial wine in a cough mixture. One patient who suffered from muscular contraction associated with anaesthetic leprosy experienced such relief from one intravenous injection of tartar emetic that he asked for more injections to be given him. A similar request was made by some female lepers whose legs were covered with extensive ulcers requiring constant dressings. Not only did the ulcers appear to be cleaning up as a result of the intravenous injection, but the patients had experienced relief. The cost of dressings at this leper institution, which contains about 750 lepers, is about £3,000 a year.

An even more striking effect of the drug was seen in a large number of leper patients requiring cough mixture. To the usual expectorant mixture containing squills was added *vin. antimonialis* *mxx* to *xxx*, t.d.s. This was used as the stock mixture for leper patients, and was rather pleasant to take. Several of the patients found such relief that they continued to take the mixture containing *vin. antimonialis* *mxx* for some time after the cough had disappeared. From what has been observed at this asylum it would appear that the use of antimony is particularly indicated in "chest" cases.

The sodium preparation of antimony would appear to give equally promising results. At the Campbell Medical School in Calcutta Dr. Upendra Nath Brahmachari reports that some cases of leprosy seem to have much benefited under treatment with antimony given in the form of tartar emetic in 2 to 5 c.cm. doses of a 2 per cent. solution twice a week. In one case the patient had ankle-drop with marked patches of anaesthesia and leprotic nodules.

Spontaneous disappearance of the active signs of leprosy occasionally occurs in leper patients. I have recently seen such an arrest in a patient who was a partial cripple; but as a rule these spontaneous improvements are gradual, the improvement taking several weeks before all signs of active disease disappear. In the case of Sital, reported in the *BRITISH MEDICAL JOURNAL* for December 4th, 1920, p. 855, all the ulcers dried up in nine days or after five intra-

muscular injections of Oppenheimer's colloidal preparation of antimony, and, although the patient has been kept under careful observation by his district surgeon since his discharge from hospital, there has been no recurrence of the active signs of leprosy for five months. One must bear in mind, however, that in view of the possible infectivity of insects with *Bacillus leprae*, exposure to fresh infection is not unlikely when leper patients are allowed to return to their homes. In their *Manual of Tropical Medicine*, 1919, p. 1650, Castellani and Chalmers state: "The difficulty of cultivating the germ on ordinary media is very suggestive of its being accustomed to live solely in animal tissues; while the abundance of the bacilli in the skin is also suggestive of that being the natural method of leaving the body."

It is to be regretted that a pathological laboratory is not attached to each leper asylum. Without such facilities at the institution itself, the means of ascertaining the cause of the spread of the infection and of determining the effect of treatment are very limited.

The healing of the ulcers under treatment with preparations of antimony is probably due to the bactericidal action of the drug; I have noticed a similar improvement in treating by intravenous injections of antimony patients who were suffering from a cloudy condition of the urine due to the presence of *B. coli* or the gonococcus. The immediate improvement that occurs after only one or more intravenous injections in such patients indicates a further way in which antimony may prove of value in the treatment of leper patients, many of whom develop a chronic cystitis, probably associated with paralysis of the bladder and *B. coli* infection. In such cases intramuscular injections of a colloidal preparation of manganese might well be combined with the antimony treatment, as I have sometimes recommended in the treatment of bilharzia cases.¹

In view of the gradual breaking down of the shells of the bilharzia ova during a course of treatment with antimony, the rapid improvement of leper patients may also be due to the action of the drug on the capsule of the bacillus. In the *Medical Journal of South Africa* for July, 1917, Drs. A. J. Orenstein and Watkins-Pitchford confirm the observations of Sir Leonard Rogers as to the value of intravenous injections of tartar emetic in the destruction of crescents in subtertian malaria. In their series of cases the danger of unskilled administration of tartar emetic injections is well emphasized.

Though several other preparations of antimony are much less toxic than tartar emetic and less liable to give rise to local reaction, oscol stibium, which is now being used in at least four different leper asylums in South Africa alone, must be used with as great caution as any other preparation of antimony. Injected into the muscle, this preparation gives rise to practically no local reaction or discomfort, unlike collosol antimonial (Crooke's), which often causes pyrexia and local swelling. Intravenously oscol stibium can be injected up to 12 c.cm. at least without toxic symptoms, provided the dose is gradually increased from an initial intravenous injection of 1 c.cm. In cases of leprosy oral administration of the drug may be combined with intramuscular injections, if so desired. Although I have not seen any very great advantage from intravenous injections of oscol stibium over the intramuscular injections, the best results would appear to have been obtained where the drug has been pushed until toxic symptoms, such as diarrhoea, have shown themselves. This is likely to occur after a total of 20 c.cm. has been given intramuscularly over a period of ten days.

If, however, the drug is injected outside the lumen of the vein selected for an intravenous injection or if it is injected into the deep tissues outside the muscle chosen for an intramuscular injection, a painful swelling gradually forms and a large abscess supervenes. Though one does not see the same painful swelling that occurs when a solution of tartar emetic is unskillfully injected, the abscess will have to be opened, and such mistakes should be most carefully avoided, especially in emaciated leper patients.

REFERENCE.
¹ *Lancet*, April 17th, 1920.

DR. E. SELLNACH, professor of physiology in the University of Vienna, has been invited to the University of Stockholm, where he will continue his researches on the interstitial glands.

ACUTE RETENTION OF URINE COMPLICATED BY PERFORATION OF A DUODENAL ULCER.

By G. A. EWART, F.R.C.S.

ASSISTANT SURGEON, ST. GEORGE'S HOSPITAL.

THE case described below presents several interesting points. It seems especially worthy of record because it affords an example of strain being the actual cause of rupture of a duodenal ulcer. An interesting question arises as to what is the best line of treatment of retention of urine under such circumstances. If I had again to deal with such complications, I would empty the bladder prior to opening the abdomen. This done, I would again do a suprapubic cystostomy on account of the general gravity of the condition and the marked urinary infection—providing ample prevesical drainage—rather than attempt any form of external urethrotomy.

Clinical History of the Case.

The patient was a man, 34 years of age, who for the past few years had had increasing difficulty in micturition, and for the past two months had noticed that his urine was very thick and offensive. There was also a history of somewhat indefinite indigestion, without, however, any vomiting, hæmatemesis, or melæna.

On March 25th, 1920, the patient, being unable to pass water, consulted a doctor. An attempt at catheterization proved unsuccessful, and, as it led to considerable hæmorrhage from the urethra, was abandoned. The patient was sent home and advised to take a hot bath, which failed to afford any relief.

At 12.30 a.m. on the morning of March 26th, when violently straining to pass water, the patient was seized with an agonizing pain in the upper abdomen which felt as if "something had given way." When eventually the patient was able to attract attention, and medical aid was summoned, the practitioner called in discovered the patient in a collapsed condition, and almost unable to give any account of himself. The abdomen was found to be rigid and tender all over. A hypodermic injection of morphine gr. 1.3 was given, which afforded some relief. On being called to see the patient I found him in great pain, but obviously somewhat recovered from his shock.

On examination it was found that the abdomen was distended, universally rigid, and tender, the liver dullness being absent. Palpation of the bladder was impossible owing to the rigidity of the overlying muscles, but on percussion it was estimated that it reached fully an inch above the umbilicus. On consideration I came to the conclusion that in addition to retention of urine the patient was suffering from the perforation of a gastric or duodenal ulcer. He was accordingly moved at once to a nursing home. On trying to pass a catheter an impermeable stricture was found lying immediately in front of the triangular ligament. Under these circumstances it was decided to open the abdomen at once, and to deal with the bladder condition at the end of the operation.

First Operation.

A general anaesthetic was given, and a small incision was made through the lower right rectus segment, with the idea of confirming the diagnosis, and for future drainage. On opening the abdomen, free gas and a fair amount of turbid fluid was discovered, the intestines were injected, and the bladder was seen to reach above the umbilicus. No attempt was made to find the appendix. The abdomen was next opened by a second incision over the right upper rectus segment. The stomach and intestines generally were found greatly distended and the latter loaded with faecal matter. On further investigation, gas and fluid were found welling up from the region of the second part of the duodenum, where an indurated perforated ulcer could be felt. At this juncture the condition of the patient was so bad, and the difficulties of manipulation caused by the distension of the intestines and bladder so great, that it was deemed inadvisable to make any prolonged attempt at closing the perforation—a proceeding which would have been difficult under the most favourable circumstances. A large drainage tube was therefore passed to the seat of perforation, and another through the lower incision into Douglas's pouch, and after a brief attempt to cleanse the peritoneum, the abdominal cavity was closed. A suprapubic incision was next made and the bladder opened. A drainage tube was introduced and fixed in the bladder by means of a soft catgut suture, and the suprapubic wound was partially closed. The urine was found to be phosphatic and very foul-smelling.

The patient, whose condition improved slightly when the abdomen was closed, was put back to bed in the Fowler position. Rectal salines and eserine sulphate gr. 1.50 were given every four hours. The morning after the operation the patient's condition was fair, considering the gravity of the case; but towards evening vomiting started, and for the next three days there was hicough, absolute constipation, and gradually increasing distension.

On the fourth day the bowels were eventually opened after the administration of eserine sulphate, calomel, pinitrin, and various enemata, and the condition of the patient greatly improved. All drainage tubes discharged freely, the urine being

collected from the suprapubic wound in a Hamilton-Irving apparatus. From this point onwards the abdominal condition progressed favourably, and the upper incision healed without the formation of a duodenal fistula. On the eleventh day after the operation the sutures were removed. This was at once followed by the opening up of the suprapubic wound, which discharged a large quantity of pus, the drainage of the pre-vesical space having evidently proved unsatisfactory. On account of the discomfort caused by the escape of urine over the excoriated skin it was decided to deal with the urethral stricture at once.

Second Operation.

Accordingly on the twelfth day after the first operation a general anaesthetic was again given. At this second operation a No. 2 (French size) bougie after considerable difficulty was passed into the bladder. This bougie was withdrawn, and an attempt made to pass the guide of Thomson Walker's urethrotome. This was, however, found impossible owing to the tip of the instrument always catching in a small crypt, or false passage. The bougie was again passed, and the guide of the urethrotome tied to it with a short length of silk. The distal end of the bougie was then caught with forceps in the bladder, through the suprapubic wound, and the guide pulled through into position. The urethrotome was attached, passed into the bladder, and the stricture divided. A No. 14 (English) metal sound was then passed, following this a No. 12 (English) gum-elastic catheter was tied into the urethra, and finally a large drainage tube was placed in the pre-vesical space.

The vesical condition gradually improved under treatment. Three weeks after the second operation, the suprapubic wound being dry and the urine free from gross infection, the patient was allowed to get up. Subsequently a No. 12 (English) sound was passed at intervals. It is gratifying to be able to add that the patient has had an uninterrupted convalescence.

Notes by E. B. TURNER, F.R.C.S.

On being called to this case, which I then saw for the first time, at 1.30 a.m., I found the patient exceedingly collapsed and suffering intense pain. The only history I could obtain at that time was one of retention of urine, becoming acute in the afternoon, and an attempt at catheterism, which failed. After this failure the patient was advised to return home and sit in a hot bath. This was done, without relief. Soon after, when straining hard, on attempting to pass water, he felt "something give way" in the abdomen, and was at once in acute agony. I found the bladder tense and distended, the abdominal walls retracted, tenderness in the epigastric region, a small weak and flickering pulse. The patient was sweating profusely, and his expression was "pinched" and anxious. I came to the conclusion that probably a duodenal ulcer had given way, and that operation as soon as possible was necessary. The bachelor flat in which the patient was living was quite unfitted for a laparotomy, and his collapsed condition precluded immediate removal. Under these circumstances I decided to break the rule which I have always observed, not to give morphine in early abdominal cases lest the symptoms be masked, and I injected that drug for two reasons: first, that by relieving the pain he might become less collapsed, and second, that if there were a perforation the paralysis of the intestinal muscles and consequent distension of the bowel might to some extent plug the perforation and hinder further leakage. At 7.30 a.m. I found him better and much less collapsed. No other change. I got Mr. Ewart to see the case, and the subsequent developments are recorded above.

Memoranda:

MEDICAL, SURGICAL, OBSTETRICAL.

CALCIUM IN THE TREATMENT OF PULMONARY TUBERCULOSIS.

For the last two years I have been giving calcium lactate to a majority of the 94 patients in the Ayrshire Sanatorium, and I am convinced of the benefit accruing. After considering certain facts as to calcium metabolism, and bearing in mind certain clinical manifestations of tuberculosis, I came to the conclusion that if calcium could be absorbed it might prove of great value in the treatment of tuberculosis.

The female loses a great deal of calcium with the menstrual blood; hence in cases of excessive ovarian activity calcium may become deficient. In many girls and young women, and in some women at the menopause

who are found to be also suffering from pulmonary tuberculosis, one of the distressing symptoms is menorrhagia; this condition can almost invariably be benefited by the administration of calcium. Calcium largely ceases to be excreted during pregnancy, the retained calcium being used up by the growing foetus; during lactation calcium is largely secreted in the milk, and this is probably the chief reason why lactation has such a prejudicial effect on tuberculous women. The high content of calcium in milk may be one of the reasons for milk holding such an important position in the dietary of the tuberculous; and therefore when milk is difficult to obtain it might be well to give children calcium. The reproductive organs seem largely responsible for calcium waste, and even in males sexual excesses are accompanied with calcium loss. I have found calcium useful in treating young adult males, and it would probably be useful in the treatment of neurasthenia.

The effects observed during the administration are as follows: Fall in temperature, cessation of night sweats (rare in a sanatorium), increase of energy, cessation of menorrhagia, retrogressive changes in the lesion, and benefit to anaemic conditions.

The drug has for the most part been given as a powder of 15 grains of the lactate every night during alternate weeks; it is quite easily taken in this way, though in a few cases it has been given in solution.

I should like to acknowledge the assistance I have received in this investigation from the works of Dr. W. Blair Bell of Liverpool.

EDWARD E. PREST, M.A., M.D.,
Medical Superintendent of the Ayrshire Sanatorium.

THE CEREBRO-SPINAL FLUID IN ENCEPHALITIS LETHARGICA.

DRS. DENYER and MORLEY (BRITISH MEDICAL JOURNAL, February 5th, 1921, p. 191) relate an interesting case of this disease, in which 10 grains of hexamine was administered intravenously. They remark: "The indications seem to point to hexamine being of value." The patient, however, died. The following case is almost identical with that related—with the exception of laryngeal spasm—and this case seemed to be so hopeless that no treatment whatever was adopted beyond cleansing the mouth and general attention. The patient, however, recovered.

C. M., aged 25 years, after a mild febrile malaise lasting five days, became drowsy and complained of headache. He was restless, refused food, and was somnolent. The following morning and throughout that day the condition remained the same, but the following night he became wildly delirious, and had to be forcibly restrained on several occasions. On the third morning he was completely unconscious; there was weakness of the right side of the face, but no definite paralysis. Both pupils were widely dilated but reacted to light, the left pupil being larger than the right. Occasionally spasmodic contractions of muscles occurred, but there was no definite rigidity, no head retraction, and all muscles were flaccid as a rule. No squint or ocular paralysis was present, no rash, cyanosis, or sweating. There was incontinence of urine and of faeces but no distension of the bladder. The urine was normal. Kuejerks were markedly increased; Kernig's sign was slightly positive, Babinski's absent, and there was no ankle-clonus; *tache cérébrale* and abdominal reflexes were present. The spinal fluid was reported on examination by a pathologist, to be in all respects normal (after thirty-six hours' unconsciousness).

For the three following days the patient remained completely unconscious. There was mild irregular fever, and on the sixth morning consciousness gradually returned and the patient regained all his normal functions. Recovery, which took place within the next few days, was uneventful.

The fact that the cerebro-spinal fluid was normal in the early stage seems to be in accordance with the explanation offered (JOURNAL, February 19th, 1921, p. 277) in the case of four fatal cases where the *post-mortem* examination showed no histological signs characteristic of encephalitis lethargica: "The probable explanation of the negative results of examination of the brains of the fatal cases is that the course of the disease was so rapid that there was not time for the characteristic changes to appear in the central nervous system." It is, however, a matter of surprise that not only were microscopic changes absent from the brain, but that the cerebro-spinal count should remain normal for at least thirty-six hours after the supervention of complete unconsciousness, and would suggest the correctness of the clinical diagnosis to be

doubtful. Since Professor MacIntosh produced a fatal lethargic illness in a monkey by means of intracerebral and intraperitoneal injection of a filtered emulsion of cerebral tissue, which did not show any histological changes but nevertheless came from a fatal case of encephalitis lethargica, the examination of the cerebro-spinal fluid in the early stages of the disease appears likely to be without any diagnostic utility.

Southsea.

R. HAMER HODGES, M.B.LOND.

TRANSVERSE CERVICAL LACERATION.

A CASE very similar to those recorded by V. Heiss, and reported in the BRITISH MEDICAL JOURNAL of February 19th, 1921, in the Obstetrics and Gynaecology section of the *Epitome of Current Medical Literature*, occurred in my own practice.

On June 11th, 1918, I was sent for by a midwife to render assistance owing to "delayed labour." On examination of the patient, who was a multipara, I found that there was an obstruction to the passage of the head along the vaginal canal, caused by the protrusion through a transverse laceration of the cervix of an elongated bag of waters. The os externum was fully dilated, and the bag of waters normally presenting there had already ruptured, but the secondary bag almost completely filled the vaginal canal, thus preventing the passage of the head. On puncturing this the head rapidly came down, and the child was born within a few minutes. The cord was divided, but when the placenta was expelled it came through the tear, so that the cord had to be returned to the cervical canal before it could be delivered. The tear was stitched up and healed completely.

S. CAPLAN, M.D.BRUX., M.R.C.S., L.R.C.P.

London, W.

Reports of Societies.

ERADICATION OF TUBERCULOSIS IN MAN AND ANIMALS.

A COMBINED meeting of the Royal Society of Medicine and the Central Branch of the National Veterinary Medical Association was held, under the chairmanship of Sir JOHN BLAND-SUTTON, on March 14th, to discuss "The eradication of tuberculosis in man and animals." The meeting was consequent upon a previous one held on February 3rd, when the more general subject of "Diseases of animals communicable to man" was the subject of an address by Professor Hobday (BRITISH MEDICAL JOURNAL, March 5th, 1921, page 351).

Bovine Tuberculosis.

Sir JOHN McFADYEAN, in opening, said that no one could accuse veterinary surgeons of neglecting the subject of communicable diseases. To a certain extent it had become almost threadbare, and some aspects were not always presented in quite the right perspective. It was true that the diseases of animals which were transmissible to man formed a considerable list, but, apart from tuberculosis, the cases of actual transmission of these diseases in this country were about as frequent as the occurrence of deaths from lightning in summer. If all the cases occurring in this country of transmitted disease were divided equally among all the veterinary surgeons, each surgeon would only have to do with one case in three years, or, in certain of the diseases, one in ten years. Where, then, was the proposed specialist in transmissible diseases to find his material? Tuberculosis, however, was in a different category altogether. It was a disease met with in all the domesticated species, mammalian and avian, though it was now generally agreed that the avian was a distinct disease, and was transmitted rarely, if ever, to human beings. For veterinary surgeons the question almost entirely was that of bovine tuberculosis; only a very small proportion of cases of tuberculosis met with in veterinary practice were distributed among other species. Bovine tuberculosis was an independent disease. The eradication of tuberculosis from the human race, and from all species of domesticated animals other than bovine, would, as far as one could see, still leave the incidence of bovine tuberculosis absolutely unaffected. On the other hand, the eradication of tuberculosis from cattle would

reduce almost to vanishing point the cases of tuberculosis met with in other domesticated species, and would appreciably reduce the incidence of tuberculosis in man. It was impossible to say what was the percentage of tuberculosis among young bovine animals up to the age of 2 years; slaughterhouse statistics and records of tuberculin testing on a sufficient scale were lacking. But there was evidence to show that the incidence was not high in young animals. It rose with age, and became serious only in animals over 2 years old. Among adult cattle the proportion affected was not less than 30 per cent.: he believed it to be higher. The eradication of tuberculosis from the cattle of this country was only possible if it could be carried out regardless of cost. It would involve the compulsory tuberculin testing of all cattle and the slaughter of the animals which reacted. That would mean the slaughter of from 750,000 to a million cows or heifers. No Government would find the money to compensate for such a slaughter, and even if it did take place the result would be so to reduce the milk supply as to drive up the price to an impossible figure. If instead of slaughtering all the affected animals they were placed in isolation such isolation would have to be permanent, otherwise the disease would not be eradicated, and it would extend from animals known to be affected to animals which had been put aside provisionally. But the owners of valuable pedigree herds might do a great deal towards the eradication of tuberculosis from the herd. Most of them were wealthy men, and had facilities which made eradication a possible policy. The Research Institute in Animal Pathology at the Royal Veterinary College had recently made an offer to the owners of any pedigree herds in this country to lend free assistance, including the supply of tuberculin, and some few very valuable herds had already been placed in the hands of the Institute. If wholesale measures of eradication were impossible, a more moderate measure to prevent the infection of human beings might be taken by reviving the Tuberculosis Order, which was introduced in 1913 and suspended on the outbreak of the war, to cut off the supply of milk from cows with tuberculosis of the udder and from other cows that presumably were passing tubercle bacilli. The infection through meat had no doubt been immensely exaggerated in the past; milk was the chief avenue of infection, and accordingly he proposed:

That the Fellows of the Royal Society of Medicine and the Central Branch of the National Veterinary Medical Association, assembled in joint meeting, are of opinion that the prevalence of tuberculosis among cattle in this country continues to be a serious menace to the health of human beings, and that to counteract this danger the reintroduction of the Tuberculosis Order, which was suspended in 1914, is urgently required.

The Milk Problem.

Professor LYLE CUMMINS (Cardiff), who seconded the motion, referred to the great amount of patient research being carried on by Dr. Stanley Griffiths and other workers, and he had no doubt that in the course of time much more would be known about the actual importance of bovine infection to man. It could be said for certain that bovine infection gave rise frequently, in children at any rate, to meningitis. A large amount of abdominal tuberculosis was due to the same cause. But, taking the whole pool of human tuberculosis in England, what really counted was phthisis, and in this connexion he recalled the interesting light thrown on phthisis by Dr. Brownlee in his recent statistical investigation, which showed that throughout Great Britain there were two types of mortality—a young adult type and a middle-aged type; and that while the young adult type led to a preponderance of deaths in certain areas, chiefly great scattered areas, it was the middle-aged type of death chiefly which obtained in London and other great aggregations of population. The young adult type appeared not to be correlated in any way with milk, whereas the distribution of infected milk appeared to be definitely linked up with the middle-aged type of death. This circumstance did suggest that, although death eventually occurred, the total period of the disease was prolonged in the class of cases in which milk infection might be concerned, so that there must be some influence as a whole favourable to the people where the tuberculosis terminated in the middle-aged type of mortality as compared with the people who died rapidly

of the young-adult type. Some of that prolongation of the effects of tuberculous infection might possibly be due to a partial vaccination by a bovine strain. He knew that this was dangerous ground, but such a vaccination was very plausible and seemed to cover a great many of the facts. On the other hand, he would regard the advocacy of such vaccination as entirely unjustifiable, because this vaccination, even if it existed, could not be controlled. He could not free his mind from feeling that it did exist, and played a very important part in the great diminution of fatal phthisis which had taken place in recent years; but to advocate it was a different thing, for the knowledge of it was not yet established, and, even if it were, it would have to be admitted that milk as a vaccine could not be controlled as regards dose. The only policy, therefore, was to better the milk supply and diminish infection. The means of transportation and distribution of milk were extremely uneconomic. This essential nutriment was sent over the country in very dilute form. The volume of milk in proportion to its nourishing qualities was large. It was a matter for the physiologist to tell them whether, without depriving children of necessary vitamins, the bulk of milk might be diminished by drying processes, and yet the risk of producing deficiency disease be negligible. This voluminous and difficult material was liable always to contamination by other germs in transit, and if it could be diminished in volume, without losing any physiological essential, a purer milk supply would be assured. Here again, however, our knowledge was not yet complete.

A Plea for Comparative Pathology.

Sir CLIFFORD ALBUTT said that he would be only wasting the time of the meeting if he were to enter upon the large field of tuberculosis in the endeavour to illustrate or enlarge that subject. Moreover, those present had heard technical addresses, and would hear yet others, dealing with these matters in an intimate way which he, on this occasion, did not propose to follow. He would take another line—a paradoxical line—by asking: What was the good which tuberculosis had done for the human race? Had not tuberculosis brought certain benefits to mankind? He remembered in his early days, when he began practice in Yorkshire, that the Yorkshire dales—those long valleys of the Wharfe and the Swale and the Don—were full of enteric fever, which was endemic in those places. It was looked upon either as a kind of visitation from God or as something in the atmosphere, in any case wholly outside human interference. So things went on until the appearance of the excellent work which was done upon the enteric bacillus, and thereby some notion of the way in which disease arrived and might be met got driven into the minds of the people. Before that time—and often, he regretted to say, since that time—the farmsteads in those valleys were centres of stench, and vermin, and disease, and one might as well have talked to one of his own bullocks as to the farmer on the way in which disease arose in those places and how it might be counteracted. The same was true of the squire; he was just as stubborn as the rest. And in that respect the enteric fever brought with it this benefit, that it did have the effect of informing the people as to the causation of disease. It was useful to consider in what respect tuberculosis had done something of the same kind. Koch's discovery of the tubercle bacillus in 1882 was like a stone cast into a stagnant pool. People began to realize in what way disease was bred amongst them—that it was due to a living virus which it was for them to discover and counteract. In that way a great piece of education was carried right among the people by tuberculosis. The thing was taught even to the babes and sucklings—to such innocents, for example, as the butcher and the milkman. Even these people were obliged to become, in a sense, scientific. Only recently, to take another example, the world had been made aware of the wonderful results obtained in the case of glanders by the veterinary schools in the war. Glanders was diminished—he might almost say obliterated—and the work with mallein was seen by every stable boy. That was the first lesson. These schoolmasters chastized us with scorpions, but they also instructed us. The second lesson was that if a successful campaign against these diseases was to be undertaken it must be a long and slow and laborious business. That was what the public even

now would not see. The public would bestow a relatively small sum for investigation and ask for results in three months. Tuberculosis was teaching the public, however, that the investigation of any one of these diseases, or even parts of any one of them, must be long, slow, and extremely expensive. In the growing of crops it was necessary first to clear the ground, and then to plough and harrow, which took a long time; and even after the seed had been cast it lay apparently dead for months before the blade appeared. Not less patient must be the investigation of disease. It was a long and costly process, and the public must learn that means had to be provided for its continuance, while the men who were engaged upon this enormously difficult question must also recognize that it would take a long time, and they must work with faith and hope, sure that the results would come some day, though they could not say when. The third lesson was this: that if these great questions were to be understood—and they were confining themselves to the question of immediate pathology, of tuberculosis among other diseases—there must be a combination of forces. The large principles of disease would never be determined until there was a system of comparative pathology, with establishments of various kinds for its study on a large and sufficient scale. At present the work was being done, though with very great success, in departments which were almost isolated. Good work had been done alike by the entomologists, and in the veterinary schools and in human medicine, but all were working in their independent ways. So far as he knew, pathology was the only subject which had hitherto declined to call—or at any rate had been supine in calling—the comparative method to its aid. Anatomy could not live without comparative anatomy. Law made use largely of comparative history; the study of religion, of philology—wherever one looked, the same comparative method was followed. None of these subjects could have attained its present position without comparative study. The establishment of the study of comparative pathology, and the linking together of the several departments, would greatly aid and encourage investigation, and would counteract the tendency to extreme specialism; there must be specialism, of course, but it need not involve isolation.

Sir Clifford Allbutt went on to say that he was sanguine enough to believe that, with the presence of distinguished veterinarians at the Royal Society of Medicine that evening, they had the beginning of a comparative pathology. They had heard what Sir John McFadyean had said; they had recently had placed in their hands a new edition of the work on pathology by Major-General Smith, and they knew the admirable work done by Professor Hobday and others, as exemplified in the *Journal of Comparative Pathology* and elsewhere. Mr. Scott of Bridgewater and others were working hard at the establishment of a systematic study of pathology, embracing more than their own subjects. On his (the medical) side he was afraid the links were few; one of the strongest was the chairman of the evening (Sir John Bland-Sutton). As Professor Stanley Gardiner had remarked the other day, millions of the best of our race owed their lives to the labours of forgotten men of science who laid the foundations of our knowledge of the generations of insects and flat worms, the modes of life of lice and ticks, and the physiology of such lowly creatures as the amoeba, leading up to the parasites of malaria, typhus, dysentery, and so on. All that knowledge thus acquired would bear its best fruit in the field of comparative pathology. Who was not astonished to read in the newspapers recently that even herrings depended on sun spots? The whole doctrine of evolution was comparatively recent and had not yet come into pathology as it ought to have done. He was thankful that the veterinary profession had come to their support that evening. While there could, of course, be no fusion, co-operation in common work was feasible, and this should obtain, not merely between human and veterinary medicine, but between entomologists also, and workers in the whole field of animals and plants. That must be largely the work of the universities. He was not entitled to speak for any other university than his own, but at Cambridge they would never think of establishing a veterinary school. The practical work must be learned in special large centres. He did not know what might be the position in the northern universities, but neither

Oxford nor Cambridge was so placed as to be able to have—even if it ought to have, which he did not believe—a veterinary school. It was, however, the business of the universities to establish schools of comparative pathology on those broader and more abstract lines, while the actual work for the professions might continue to be done in the large centres. Veterinarians had their own school, and had, and always would have, their one portal. But it was the business of the universities to link up, if possible, all these various practical fields, and to teach the application of certain broad scientific principles. It was these three lessons which he ventured to think, tuberculosis had helped to teach mankind, and to that extent it had benefited the race. He was very glad to hear the other day that a committee for comparative pathology had been started, and that Sir David Prain was to be the chairman. That showed, at any rate, a desire that it should be on the broadest lines of comparative work, which included work on plants, for they must remember that when they were speaking of the pathology of enteric fever and similar diseases they were speaking of plants and of unicellular plants, which had so vast an influence over the destinies of mankind.

Dr. A. C. ISMAN said that an immense amount of patient and careful work had been done since Koch's discovery to establish the extent to which the bovine type of bacillus infected man, and which type, human or bovine, was the more important in human disease. On taking cultures from all types of tuberculous disease in man it had been found that the bovine infections for all ages worked out at 18.7 per cent. of the total number of cases. But on analyzing these forms of tuberculous infection in man great differences were found. In phthisis, taking all ages, the percentage of bovine infection was only 1.4, while cultures made from tuberculous glands in the neck in young children during the first five years of life showed the bovine infection in 85.7 per cent., and between the ages of 5 and 10 in 65 per cent. The bovine infection, therefore, was a reality, and great precautions must be taken about the consumption of infected foodstuffs. Unhappily, in the case of tuberculous infection, there was not, as yet, any certain means of diagnosing the disease at an early stage. Some test was wanted whereby the disease could be diagnosed before bacilli appeared in the sputum.

Dr. HALLIDAY SUTHERLAND argued for agreement upon certain general principles. After Koch's discovery, right up to the present time, nine people out of ten when asked what was the cause of tuberculosis would reply, "The tubercle bacillus." Philosophically, that was wrong. Tuberculosis was the result of the bacillus on the one hand and of a lack of resistance of the body on the other. The fighting bulls of Spain were free from tuberculosis because they led a life in the open. Tuberculosis was an expression of an imperfect civilization. Apart from the discovery of a definite specific, like "606" for syphilis, all their efforts would be only partially successful until the resistance of the race was improved and man was made to lead a healthy life. The idea that any good would be got from tuberculous milk as a means of vaccination seemed dangerous. It might be uttered in a medical meeting without doing any injury, but it would be taken up by dairy farmers and agricultural papers and used as an argument against doing anything in the matter of tuberculous milk. If there was anything in this vaccination, let all children be vaccinated with cultures of tubercle bacilli, but first let the results of protective inoculation both of cattle and guinea-pigs be called for; so far these results had failed to warrant the application of that theory to man. He thought it dangerous to rely upon laboratory diagnosis in medicine. While nothing was perfect, they had at present in clinical methods of percussion and auscultation, verified by x-ray examination and the tuberculin test, a good working technique whereby tuberculosis might be diagnosed at least two years before the bacillus appeared in the sputum.

Professor F. HOBDAY said that workers in human and veterinary medicine covered much ground in common, and by working in unison better results would be obtained than if each side kept within a watertight compartment.

Sir JOHN McFADYEAN, in reply to the discussion, said that the incidence of tuberculosis at different ages in man could be explained without assuming that milk from tuberculous cows was an important factor at all. He denied

that Spanish bulls of the ring were free from tuberculosis, and he knew that tuberculosis might occur to a somewhat serious degree among ranch cattle which had never been under a roof.

The resolution calling for the reintroduction of the Tuberculosis Order was carried unanimously.

THE NON-OPERATIVE TREATMENT OF SURGICAL TUBERCULOSIS.

At the meeting of the Medical Society of London on March 14th, with Sir WILLIAM HALE-WHITE, the President, in the chair, a discussion took place on the non-operative treatment of surgical tuberculosis. The opening paper was read by Sir HENRY GAUVAIN, medical superintendent of the Lord Mayor Treloar Cripples' Hospital and College, Alton, Hants. He said that he would confine himself to tuberculous disease of the bones, joints, and glands, in which conditions non-operative treatment might now be usually adopted with confidence and a reasonable assurance of success. In certain other non-pulmonary tuberculous lesions—for instance of the kidney—operative interference still had an essential field, but in such situations as the meningitis of the brain treatment of any sort remained almost futile. Operative treatment of an active tuberculous lesion was based on a false pathology, except when the lesion occurred in a situation where its presence was incompatible with life. Lannelongue showed that the progressive extension of a tuberculous abscess towards the skin was not a mechanical phenomenon, but was the result of primary infection and subsequent excentric destruction of tissues by tuberculous elements advancing in the manner of a neoplasm. Hence was evolved a radical treatment which had arrived at the total extirpation of tuberculous tissues, but this practice, possible and efficacious with small tuberculous foci, exposed the patient to serious danger when applied to extensive bony lesions. The mortality, both immediate and indirect, after major operations was appallingly high, and in the survivors, especially growing children, the extensive mutilations gave deplorable orthopaedic results.

To the "tuberculome" theory the conservative surgeon opposed a theory based on the defensive resources of the patient. A tuberculous lesion provoked a reaction, there was the formation of a zone of resistance about the focus of the disease by the formation of fibrous tissue which encysted, limited, and tended to prevent the progress of invasion. Thus the issue was the result of two opposing forces—the disease which attacked the organism and the reaction which this attack provoked. It appeared reasonable to reinforce this natural defence and diminish the virulence of the attack of the bacillus, limiting in this way its progress. To this day there was too great a tendency to concentrate unduly on the local lesion, and to disregard the fact that the patient himself had contracted a general disease, of which any particular lesion or lesions were merely local manifestations.

The title "non-operative treatment" of surgical tuberculosis conveyed no suggestion as to what the treatment, if non-operative, might be. Treatment, where operation was avoided in these conditions, was usually termed conservative, but that term again was open to criticism. He defined conservative treatment in surgical tuberculosis as the adoption of all measures tending to improve the patient's general health, to increase his powers of resistance to tuberculous disease, and to preserve or restore the part or parts attacked, in contradistinction to radical treatment, which aimed at the cure of the disease by the removal of the local lesion. Such a definition was the very antithesis to lack of treatment; it necessitated very active, numerous, and complicated methods being employed, and implied that surgical procedures were by no means necessarily excluded. Chronic disease, which of necessity involved lengthy treatment, had for too long been regarded from the purely pathological point of view, the intellectual and industrial aspect of the problem having been ignored. This state of affairs should have been remedied long ago. All child patients should be educated, and manual instruction should play a large part in the scheme; adolescents should be trained in work suited to their limitations, and adults occupied. To assist in carrying out that part of the work, on the educational side fourteen trained teachers,

and on the technical five trained instructors, were employed at Alton. Sir Henry Gauvain advocated the establishment of properly equipped "preventoria" where such children could have preventive treatment under the best climatic, hygienic, dietetic, and educational conditions, and under skilled supervision. Such a preventorium was in contemplation at Alton.

A detailed description of conservative treatment would include consideration of general treatment, involving climatic, hygienic, dietetic, drug, educational, and other methods; and local treatment, which was concerned with the correction or prevention of deformity and was largely orthopaedic in character, but was subject to those limitations which the fact that the patient was tuberculous enjoined. Under the latter heading might also be included surgical measures, which had still a place, such as the aspiration of tuberculous abscesses of bony origin. Adjuvant methods of treatment, including heliotherapy, balneotherapy, chemotherapy, vaccine treatment, and the therapeutic employment of *x* rays and other electrical agents, represented perhaps the most interesting advances made in the non-operative treatment of surgical tuberculosis. Auxiliary methods were of importance for the patient's general well-being, and comprised attention to the teeth, skin, throat, nose, ears, and eyes. Included also under auxiliary methods was a branch institution where chronic cases not requiring any special treatment might be detained indefinitely, and thus give room at the hospital for more acute patients urgently needing specialized care. In regard to after-care, all patients who had suffered from surgical tuberculosis should have the continued advantage of occasional skilled supervision, and no special hospital for the treatment of these conditions could be considered complete unless it possessed an out-patient department where discharged patients might be periodically examined, advised, and assisted. Not only was medical help required, but advice in the choice of occupation and assistance in obtaining suitable employment should be forthcoming. Lastly, the speaker's own experience was that it was fallacious to suppose that adults did not respond well to conservative treatment, though operative aid might more often be called for in those cases.

Sir ANTHONY BOWLBY said that there was a period when the surgeon set out by operation to eradicate the tubercle bacillus; after a very considerable experience of surgery he thought he could say that this was a thing the surgeon was unable to do. Here and there a surgical lesion might be removed; but what was now appreciated was that whilst the surgeon could not kill the tubercle the patient could, only the patient required perseverance and encouragement. He had been convinced, as a result of *post-mortem* investigation, that it was of no use trying to eradicate tubercle by local operation, because, on examining patients after death, it was invariably found that they had tubercle in some other part of the body. The growth of tubercle in bone acted as a solvent on the bone salts, and as a consequence a very considerable amount of bone was gradually dissolved and the fibrous stroma of which the bone was composed was ultimately removed. The patient himself did what the surgeon had often tried to do, but whereas the patient actually did remove the tuberculous material, the surgeon by his intervention took away a good deal of bone which was quite capable of recovering. It was not sufficiently appreciated that a great amount of tuberculous bone could be removed without external operation at all. Nevertheless, the surgeon was not altogether out of court. He had to step in to remove the dead material. In a great many cases, when the process had ceased, there was left behind a good deal of material, either caseous or calcified material, or purulent fluid. The surgeon usually did not require to remove the former, but the latter he could remove by aspiration. Tuberculous disease of the knee was sometimes better treated by operation, whereas tuberculous disease of the hip was rarely well treated by operation, and when the two conditions were compared it was easy to realize that the surgeon might be able to remove the whole of the tuberculous tissues of a knee, whereas the so-called excision of a hip seldom removed the whole disease. At the present time it was not sufficiently appreciated how much was required for the treatment of this class of patient. People were content to say that the patient should be treated out of doors, and so on, but, as Sir Henry Gauvain had rightly

said, the question was not one of convalescence but of treatment. And it was of no use allowing a child with a tuberculous hip simply to lie outside in the sun without appliances or any other form of special treatment. A great deal of incomplete treatment was done in these cases. Sir Henry Gauvain had demonstrated at Alton how much more than merely passive treatment was necessary.

Mr. T. H. KELLOCK said that when surgeons used to operate in cases of tubercle, except in amputations possibly, all that they did was to remove the debris, the result of the disease, and they could not hope by any operation for tubercle to cure the child. Even locally the disease was too far spread for them to hope that by excising the hip-joint or the knee they were going to remove the whole of the tuberculosis. Mr. Kellock urged the value of iodine and its preparations, which killed tubercle if thoroughly brought into contact with the organism. The application might be constitutional through the agency of the blood, and local at the seat of the disease. If a patient were given sufficient potassium iodide the disease might be, if not cured, at least brought to a standstill. Given clean tubercle, without suppuration, potassium iodide should be pushed in very large doses over a long period. In local treatment the application of the iodine was even more important. In tuberculous abscess the iodine in liquid or gaseous form must be brought into close contact with the whole of the walls. An abscess should be aspirated, and the contents replaced by an equivalent, or almost equivalent, quantity of some germicide. Personally, he always used a strong solution of iodine and potassium iodide, and, by combining the local and the constitutional treatment, a very large proportion of clean tubercle could be satisfactorily dealt with.

Dr. GORDON PUGH described various methods of fixation in spinal disease of children, including a special appliance which he used at Carshalton. Mr. W. H. TRETOWAN referred to the peculiar difficulties of the out-patient department, and the necessity for standardized treatment in hospital. He praised plaster fixation, which he thought far superior to the Thomas splint. Mr. GIRLING BALL also spoke of the difficulty of out-patient treatment, and agreed with Mr. Trothowan in his criticism of the Thomas splint for spinal disease. In his experience it was very seldom that tuberculous disease of the hip-joint completely recovered. The cases were nearly always left with a certain amount of stiffness and deformity. Mr. P. B. ROHN said that in closed tuberculosis treated without operation, under proper conditions, and in good surroundings, the prognosis was excellent. He quoted statistics from an institution in Switzerland indicating that 80 or 90 per cent. of cases were curable, and in an average time of fifteen months. In open tuberculosis the prognosis was very doubtful.

Sir HENRY GAUVAIN was precluded by the lateness of the hour from replying, but he commented on the fact that every speaker, without exception, now approved the non-operative treatment of tuberculosis.

EXOPHTHALMIC GOITRE.

THE discussion on exophthalmic goitre, which had occupied the Clinical Section of the Royal Society of Medicine, combined with the Sections of Medicine and Surgery, for two evenings (BRITISH MEDICAL JOURNAL, February 19th and March 5th), was brought to a close on March 11th.

Mr. C. A. JOLL, in reopening the discussion, said that in the true disease the danger of the operation and the degree of benefit likely to follow depended very largely on the length of time during which the disease had been present. He advocated the ligation of the superior thyroid vessels in very mild early cases, which he had occasionally seen cured by this procedure, and as a preliminary step in grave and advanced cases. The operation was simple and very suitable for local anaesthesia, and a striking improvement often followed. It was generally necessary to resect a part of the gland three to six months later, and this could be done at that stage with less risk than would be involved in immediate resection. Mr. Joll confessed himself unable to understand those who claimed that it was necessary in operating for exophthalmic goitre to remove every scrap of gland tissue in the neighbourhood of the recurrent nerve. If a small

portion of the gland were left in this situation, cases of recurrent nerve paralysis did not occur, and he understood that the incidence of this disastrous complication was very high where this precaution had not been adopted. He had often examined this little piece of gland during secondary operations for the removal of a further portion of gland, and in no case had he seen any evidence of its hypertrophy. The solution to the problem of the treatment of the disease seemed to him to lie in earlier operation, more comprehensive resection, and avoidance of haemorrhage during operation.

Dr. LEONARD WILLIAMS stated his conviction that there was no more justification for operating on the thyroid gland than for operating on the kidneys in a case of diabetes. The worst symptoms of the disease—cardiac, and following upon that, mental and nervous—were due not to the thyroid, but to the thymus, which had been too little considered. The thymus gland was enlarged in over 85 per cent. of the cases. He was not in the least anxious to take from the thyroid the part of the villain of the piece and give it to the thymus, but if a gland was to be attacked at all it should be the thymus.

Dr. C. M. WILSON said that since 1912 there had been practically no advance on the subject, and medical men were as far from agreement now as they were then; and that seemed to him a remarkable state of affairs, the more so because it had arisen, not around some difficult question of causation, but around the question of results. The terms used when speaking of the disease did not succeed in conveying to others the type of case intended or its severity, and that difficulty might be overcome by expressing in figures or curves on charts the character of any one case at any one time. One of the reasons for their backwardness in solving the problem was because they had not all got the same standard. There were too many advocates of different procedures, making too many comparative statements.

Dr. KINNIER WILSON was disappointed that so little had been heard in the discussion about the pathology of a disease treated in so many different ways. He agreed with Dr. Leonard Williams that exophthalmic goitre was not a disease of the thyroid. He would regard it as essentially a neuro-glandular disease. It was impossible to dissociate the nervous aspect of exophthalmic goitre from any of its other aspects.

Dr. MARTIN BERRY gave an account of some cases in which x-ray treatment was successfully applied. He believed that in no case of exophthalmic goitre was x-ray treatment contraindicated, except, possibly, a case in which nervous dyspnoea was present due to actual pressure on the trachea.

Dr. HECTOR MACKENZIE, the original opener of the discussion, said that allusions had been made to his "conversion" to surgical treatment, but the fact was simply that in earlier years, although he had occasional good reports of operations, and had always been of opinion that surgical treatment in certain cases was probably the best treatment for the disease, he was disheartened by the total mortality; but since 1915, when he was first introduced to Mr. T. P. Dunhill's treatment with local anaesthesia, he had found the results of operation as good as they had formerly been had under a different procedure. Of the cases on which Mr. Dunhill had operated for him, not one had been lost, and all had benefited. The chief point which came out of the whole discussion was the surgical advance which had been made, and the fact that the operation now, by expert surgeons, was comparatively safe. He disagreed with those surgeons who had advocated strongly the ligation of the arteries. This operation might be looked upon as comparatively safe, but he had never seen any really satisfactory result from ligation of the arteries alone. If operation was going to be undertaken, it was not worth while wasting time tying arteries when far better results could be got by thyroidectomy. Dr. Mackenzie went on to analyse some of the statistics which had been presented by the x-ray advocates, and maintained that they were not as convincing as might appear at first sight; many of the cases reported to be benefited by x-rays were not marked cases of the disease. In conclusion, the outlook for patients with exophthalmic goitre was very much brighter now than at any previous time. Surgery practised on the lines of prudence would help to restore many to health, and would save an increasing number from drifting into a

state of chronic invalidism. Every effort should, however, be made to cure the disease by medical means, and if operation was undertaken medical treatment must be carried out after as well as before it.

Mr. T. P. DUNHILL, who also replied, said that in cases in which ligation of the arteries could be done easily it was not necessary, and in the cases in which it might be regarded as quite necessary it was dangerous. When it was necessary for this to be done it was almost as easy and safe to remove part of the lobe. The discussion had suggested to him that there should be only one person in charge of the case, and he the physician, and that so long as the physician was piloting the patient back to health there was no need to bring in the surgeon. But when the physician found that the case was not going as it should it became a matter for the exercise of a dual intelligence, and it must be left to the surgeon, of course, to decide as to the best time to operate, the nature of the anaesthesia, and the extent of the gland to be removed.

OCULAR PALSIES.

THE Sections of Neurology and Ophthalmology of the Royal Society of Medicine, Dr. JAMES TAYLOR presiding, combined in a discussion, on March 10th and 11th, on the subject of ocular palsies, accompanied by a demonstration of cases. The discussion suffered to some extent from the extreme complexity of the subject, and from the fact that most speakers went on lines of their own, each describing a different type of palsy.

The subject was introduced by Dr. GORDON HOLMES and Mr. LESLIE PATON. The former gave a careful exposition, fully illustrated, concerning mainly anatomical investigations into the nervous and muscular structure involved. Mr. Paton sketched the various categories into which oculomotor paralysis might be divided. His grouping was: (1) Paralysis of central and cerebral origin, comprising three subgroups: (a) supranuclear lesions, (b) infranuclear lesions, (c) nuclear and nerve-root lesions; (2) paralysis of extracerebral origin—that is, of nerve trunks—again comprising two groups: (a) intracranial and (b) intraorbital; (3) paralysis of muscular origin. Nuclear ophthalmoplegias or ophthalmoplegias proper could be subdivided into acute and chronic types. Good examples of the infective type of acute ophthalmoplegias were found in lethargic encephalitis, influenza, and syphilis, but in a very definite proportion of acute ophthalmoplegias no infective agent could be found. The most important form in chronic progressive ophthalmoplegia was that occurring in tabes and general paralysis of the insane. Besides these, there were certain ophthalmoplegias of congenital origin and others which were of a distinct familial type.

Mr. BISHOP HARMAN commented on the comparative rarity of these cases. In a consecutive series of 5,000 patients he found only 27 cases of ocular palsy, 17 of whom were males and 10 females. Paresis due to injury headed the list with 7 cases, syphilis came next with 5, and general vascular disease or degeneration with the same number. Two cases due to exposure were likely to be a bone of contention between the neurologist, who was not inclined to admit such a cause, and the ophthalmic surgeon, who credited it. In one of these there were undoubted manifestations of inflammation over the affected muscle, and both cases were cured with notable rapidity. He agreed that, apart from the cases of paralysis due to direct injury to the bones of the orbit and his two cases due to exposure, the occurrence of such a paralysis was a sign of serious general disease, but his cases afforded no evidence that life was thereby shortened.

Dr. KINNIER WILSON laid stress upon the difficulty of determining the exact aetiological factor, but thought that unilateral cranial polyneuritis had to be regarded as a distinct clinical possibility. Mr. J. GRAY CLEGG described a case of ophthalmoplegia in Graves's disease, and Mr. FOSTER MOORE also dealt with the condition in Graves's disease, and said that it seemed probable that when deficient movement of the eyes occurred in this disease it was due to impairment of the function of the muscles, while marked exophthalmos would introduce a mechanical factor contributing to the same result. Dr. JAMES COLLIER described a case in which there was bilateral palsy of the sixth nerve following spinal anaesthesia. Mr. M. L. HINE

spoke particularly of the group of chronic nuclear palsies and reviewed the literature. Dr. WILFRED HARRIS raised the question as to whether a rheumatic neuritis of the motor branches of the third or sixth nerve in the orbit could be fairly diagnosed. The PRESIDENT expressed his scepticism about paralysis of the ocular muscles of so-called rheumatic origin. He had been watching for a good many years cases of seventh-nerve paralysis and had never yet seen sixth-nerve paralysis associated with it.

Dr. GORDON HOLMES, in summing up the discussion, said that his experience of ocular palsies had been considerable, especially since he had been on the staff at Moorfields, and he was always conscious of the difficulty of deciding what any palsy might be due to. It was usually only by means of associated disease that a presumptive diagnosis could be made. In all groups of ocular palsies there was a considerable paucity of careful histological work. No doubt muscular weakness was due to muscular conditions in a certain number of cases, but his experience was that in a considerable proportion of patients with Graves's disease with ocular palsy there was relatively little proptosis.

PATHOLOGY OF INFLUENZA.

At a meeting of the Pathological Section of the Liverpool Medical Institution, held on February 10th, with the President, Dr. J. E. GEMMELL, in the chair, the adjourned discussion on Dr. Adami's paper on "The pathology of influenza" (BRITISH MEDICAL JOURNAL, January 8th, 1921, p. 48) was opened by Dr. R. J. M. BUCHANAN. Dr. Buchanan said that in the epidemic of 1918, from the U.S.A. troops about 450 cases of the disease were admitted to three of our auxiliary hospitals to which he was consulting physician. The outbreak was serious, and it soon became evident that the cases could be divided clinically into four groups: (1) The mild catarrhal type, (2) the pneumonic type, (3) cases with physical signs of bronchiolitis, (4) cases of profound toxæmia, with little or no respiratory phenomena, in whom coma vigil was the rule, and who, with few exceptions, died. His clinical observations led him to the conclusion that in that epidemic they had to deal with a triple or multiple infection process. He briefly described the history of the previous epidemics, and showed that the same division into groups was seen even in the 1889-92 epidemics. He thought this similarity in classification in different epidemics supported the theory of multiple infection, and in support of this he quoted Washbourne, Lister, Gochez, Gillespie, Cole, and Sutton and Sevier.

Professor ERNEST GLYNN quoted some experiences of the influenza epidemic among the American soldiers in Liverpool: direct films from the sputa of 13 cases showed pneumococci and influenza group in 5, influenza group in 2; blood cultures from 70 cases showed pneumococci in 9, pneumococci and streptococci in 2, influenza group in 2; 22 post-influenza eupyemias showed pneumococci in 9, streptococci in 8, pneumococci and streptococci in 1, pneumonia and *Staphylococcus aureus* in 2, streptococci group in 1, while 1 was sterile. He quoted several cases in which the bacilli of the influenza group were numerous in the trachea and bronchi, but pneumococci scanty, whereas in the pneumonic lung alveoli the reverse obtained. A mixed influenzal pneumococcal and streptococcal vaccine which he had made was extensively used for treatment of the American troops, but he had no reliable data as to its value. As "influenzal pneumonia" was often accompanied by septicaemia, vaccines seemed inadvisable on theoretical grounds.

Dr. E. CROXIN LOWE, by means of a series of lantern slides and sections, pointed out the well recognized importance of the post-nasal space and accessory sinuses as the focus of primary infection in influenza. He showed that while in the simple pyrexial cases the intensely influenzal mucosa of those areas gave rise to frequent epistaxis, etc., and was associated with a toxæmia, in other cases which developed later the severe fulminating type of influenza, the condition was due to a generalized bacteriæmia, originating in the infection of the congested pharyngeal veins and extravasated blood in the sub-mucosa of this region. This was carried probably often in the form of minute infective emboli, travelling by the normal anatomical route, and would be arrested in the terminal

arterioles of the pulmonary artery, which were situated around the terminal bronchioles. In this way he considered, as Dr. Herbert French had suggested elsewhere, that the rapid and earliest lung infection took place, giving rise to a peribronchiolitis of haemic origin, which would account for the pathological appearances so constantly found present in these more rapidly fatal cases. The protective functions of the ciliated lining epithelium having been thus damaged allowed of a later infection by direct extension from the upper air passages along the bronchial tract. He pointed out that from this point of view the three important factors in treatment were regular local hygiene of the post-nasal space, prophylactic vaccination against the three organisms principally concerned—namely, *B. influenzae*, streptococci, and pneumococci—while in the actual treatment of the septicaemic type of case the prompt, early, and adequate administration of curative streptococcal or pneumococcal serums should biologically be the right treatment; generally 50 to 100 c.c.m. of serum, given intravenously and twice daily, would be required.

Dr. A. GORDON GULLAN said that when on service with the British Expeditionary Force in the spring of 1916 he observed an outbreak of influenza of a mild type without any respiratory complications, which was chiefly classified as P.U.O., or trench fever. Early in 1917 he noted cases of influenza complicated with pneumonia and other respiratory affections, but in 1918, when officer in charge of the Military Hospital, Gibraltar, two severe outbreaks of influenza occurred; the first, in June, was in several cases accompanied by respiratory complications, but in no instance with a fatal termination; the second, in October, was much more virulent, and showed signs of marked toxæmia. In this latter epidemic the respiratory type was much more prevalent, especially in the form of lobar pneumonia, often accompanied by general bronchitis and most severe cyanosis. In 355 cases, 77 developed pulmonary complications, and of these 18 terminated fatally. It was noticeable that no soldier affected in June contracted the disease in October. In the sputa which were examined the bacillus of influenza and the pneumococcus were found.

At a meeting of the Sheffield Medico-Chirurgical Society, held on March 3rd, with the President, Dr. F. J. SADLER, in the chair, Sir D'ARCY POWER read a paper on the palliative treatment of aneurysms by wiring. He showed Colt's apparatus for the rapid and aseptic introduction of wire into aneurysms, and pointed out various points of practical importance in its use. He then gave details of the more recent cases of thoracic and abdominal aneurysm in which he had employed this method of treatment and the subsequent history of the patients whose cases had been recorded in the *Proceedings* of the Royal Society of Medicine in 1912. One of the cases was illustrated by a very complete series of x-ray photographs showing the wires in position and the changes undergone by the aneurysm during a period of two years. He arrived at the general conclusion that in the majority of cases there was evidence of cure, as the patients were alive and at work ten and more years after the wire had been introduced. He also appended an interesting table of cases compiled by Mr. G. H. Colt, showing the duration of life from the first recorded symptoms to the time of death in 133 men and 8 women suffering from thoracic or abdominal aneurysms. THE PRESIDENT, Professor A. J. HALL, Professor A. M. CONNELL, Dr. A. E. BARNES, and others took part in the discussion which followed.

The London County Council has decided to grant to the four whole-time London coroners who receive a gross salary of £1,500 a temporary addition of £300 a year, to continue until such time as the Council obtains parliamentary powers to pay coroners fixed salaries or until March 31st, 1922, whichever be the earlier date. The payment is to be conditional on each coroner submitting quarterly a certified statement as to his out-of-pocket disbursements. Out of his gross salary a coroner has to pay for the services of a deputy and of a clerical assistant, as well as for office accommodation and travelling. In the pre-war period such expenditure was computed at 25 per cent. of the total income. From figures which the coroners have recently furnished, their present out-of-pocket expenses average £400 a year.

Reviews.

"PHENOMENA OF MATERIALIZATION."

William Crookes, Oliver Lodge, Camille Flammarion, Charles Richet, Lombroso, Morselli, Flournoy, Zollner, Ostwald: such is the constellation of stars which shine in the firmament of spiritistic or mediumistic phenomena. Respect for the eminence of these men induces us to deal at some length with the volume entitled *Phenomena of Materialization*, a translation into English of a book written by Baron von SCHRENCK NOTZING, "practising physician" in Munich; it is a weighty tome of 340 pages, which by its endless repetitions produces a feeling akin to the hypnotic trance. Moreover, we regard it as a duty to examine and criticize the beliefs, observations, and theorizings of the human mind, so far as time and space allow: especially when a belief has reached such a stage that thousands of mankind are deriving consolation from their faith in it. When its professors allege a scientific basis for their faith, and physiology and psychology are dragged in to support it, the duty of the medical profession to inquire into the origin and methods of the cult becomes even more insistent.

The expression "materialization phenomena" is applied to the alleged production of forms and materials of organic or even inorganic matter by a so-called medium, who, it is assumed, has been deprived of the possibility of having concealed the materials about her person or in her surroundings. The manifestations are supposed to emanate from the medium from her skin, her eyes, her mouth, or other orifices of her body. The emanations may take the form of threads, white, grey, or black, of clouds or mists, of ill-defined solid masses, of materials resembling muslin, wool, paper, or other mundane substances; hands, arms, or heads may be produced, and occasionally fully formed phantoms of distinct character and definite features and forms. In mediumistic jargon such manifestations are described as "teleplastic phenomena," as distinguished from the "telekinetic" class, which comprises the spiritists' table-turnings, levitations, raps, and "direct" writing.

In his preface Baron von Schrenck Notzing confesses that hitherto the observations of mediumistic phenomena have not fulfilled the requirements of exact scientific method, but the translator asserts that in the present work the reader has "a full scientific account of a set of strange occurrences observed under the strictest conditions of control, and as yet quite unexplained." As we have not witnessed any of the sciences we do not presume to express an opinion on the reality or otherwise of the phenomena described. But the author and his translator lay claim to the adoption of an exact scientific method, and it is with this claim that we propose to deal. Let us take first the attitude of Baron von Schrenck Notzing towards his mediums and their friends.

The medium chiefly employed was called Eva C., who seems to have been 23 years of age when the sittings began in Paris in 1909, at the house of her "protectress," Mme. Bisson. The medium had had four or five years' previous experience in spiritualistic circles. At all the sittings recorded in the book Mme. Bisson appears to have been present: at several sittings Mme. Bisson was alone with the medium, and some of the most remarkable phenomena seem to have occurred for the first time at these *séances*. Our first criticism of the author as a scientific person is in this matter of Mme. Bisson. He is very angry with people who have hinted that possibly Mme. Bisson acted in collusion with the medium. "If some savants assert that Mme. Bisson's mere presence at the sittings constitutes a source of error, this shows a deplorable lack of understanding of the complicated mechanism of the mediumistic occurrences." He speaks of the "unjustifiable and insulting insinuation against this lady," and thinks that he has disposed of the criticism by stating that Mme. Bisson, "in the spirit of a purely scientific research, repeatedly allowed herself to be examined" by him. Yet on many occasions, and "during the frequent incidents of

¹ *Phenomena of Materialization*. A contribution to the investigation of Mediumistic Teleplasticity. By Baron von Schrenck Notzing, Practising Physician in Munich. Translated by E. E. Tomlinson & Albe. D. Sc. Lond. and E. M. Lond. in: Kegan Paul, Trench, Trubner, and Co., Ltd., New York, London, and Co., 1920. (Doubleday, and Co., pp. xii + 340, 12 shillings, 12s. net.)

the sittings which would leave any other experimenter helpless. Mme. Bisson always finds the right means to restore the disturbed psychical and physical equilibrium of the medium." The right means apparently do not exclude entrance into the cabinet occupied by the medium. He goes on to say: "Besides, with what motive could Mme. Bisson, living in Paris, try to deceive a foreign savant for four years?" Because Mme. Bisson housed and fed the medium for three and a half years, "there cannot be the slightest doubt that Mme. Bisson has conducted the four years' investigation out of a pure interest in the subject, in the scientific exploration of the mediumistic problem." The fact that the lady has published her own observations "vouches for the authoress's bona fides"; and, again, "The imputation of fraudulent assistance is thus deprived of any reasonable basis."

With regard to mediums, the Baron admits the possibility of fraud in certain manifestations. Thus he says that "the person under test may, if the effort does not succeed at once, or if the forces available do not suffice, easily be led to assist, to some extent unconsciously, with the muscles." In both Eusapia Paladino and in Eva C. the violent muscular action suggested the pains of childbirth, and are described as "mediumistic labour." "In combination with a vivid desire for success they easily lead to an unconscious mechanical execution of the task by the limbs." A medium named Mrs. d'Esperance was, the author says, regarded as an honest and credible person, and while she was believed to be sleeping in a cabinet her shadow friend "Yolande" was seized. On this Mrs. d'Esperance says: "The man who had seized her said it was I. This assertion appeared to me so extraordinary and incomprehensible that I could have laughed, if my utter helplessness and weakness had not rendered me incapable of thinking or even of moving." On this the Baron remarks: "In consequence of this shock this lady of unimpeachable character broke down completely and became seriously ill." This sympathetic attempt to defend the lady may be chivalrous, but is it scientific? In describing how the spirit "Mary," produced by Florence Cook, Sir William Crookes's medium, was seized and found to be the medium herself in a flannel dress and corsets, the Baron does not even consider the possibility of fraud. He suggests "transfiguration," "transmutation," or pseudo-materialization as the explanation. We believe we are correct in saying that the earlier manifestations by Eusapia Paladino were so palpably unreliable that the Society for Psychical Research refused to investigate them further. When, fifteen years later, the medium was examined again, a committee of the same society reported that, although some of the results were still as before, there were others that could not be explained. Would it, we may ask, be scientific to assert that, because some of the tricks of a conjurer are beyond our comprehension, these tricks cannot be due to deception of our senses? Surely the scientific inference is that all the effects may be produced in a like manner, but that the means at our disposal do not allow us in all cases to perceive the deception. The Baron, however, will have none of this explanation. Everything that he cannot see through must be produced by some power of which we know nothing. If it is pointed out to him that the curtains of the cabinet in which the medium has been concealed are studded with pinholes, it does not make him sceptical in the true sense of the word. He does not institute a scientific inquiry into the way in which the pinholes occurred; he sets about giving some ingenious explanation which is merely a figment of his imagination. The great difficulty experienced by our learned men with mediumistic leanings is that the mediums take care that the ordinary methods of scientific investigation shall not be applied to their performances. Thus the Baron is continually afraid that an attempt to remove a portion of the materialization in the case of Eva C. would lead to a serious effect on her health, or might even cause her death. So far as we can ascertain from the text, the only ground for his belief is that on one occasion an unsuccessful attempt to capture a portion of brown substance from the shoulder of the lady led to an outburst which would seem to have been of an hysterical character. We think he might have been reassured by the fact that the capture of Mrs. d'Esperance in the guise of "Yolande" did not lead to death, but merely to the discontinuance for a

long time of the sittings—not, perhaps, an undesirable result. As a matter of fact some men of science seem to throw away the whole of their scientific equipment and training when they become interested in spiritistic phenomena. The Baron urges the necessity for the combination of an extreme degree of scientific scepticism with personal benevolence to the medium. It seems to us that a benevolence which for four years tolerated what appear to be deceptions growing in audacity with practice up to the production of portraits which look to us like drawings on paper, must in the end have considerably diluted the spirit of scepticism. "If," says the Baron, "we consider it *a priori* impossible to protect ourselves against prestidigitation and other fraud practised by the mediums, we thereby declare the human senses to be incapable of scientific determinations of any kind." To which we reply that if *a priori* you assume the existence of "teleplasma," and then accept conditions of investigation which practically preclude you from checking the impression of one sense by the impressions of other senses, you have in effect rendered yourself incapable of any scientific determination at all. To sprinkle a book with apologies for the "martyrdom of the medium" because even some measure of control has been attempted surely prejudices the position, and must render nugatory any claim to the scientific spirit.

The Baron's attitude to the manifested material is curiously unscientific. Thus, in one place Eva's head is covered with a white cloth. "A critic," says the Baron, "would at once have the impression that Eva had put a handkerchief over her head, but . . ." and an irrelevant detail is dragged in with complete disregard to scientific investigation. The description of this sitting ends with the statement that "the medium was obviously anxious to mask herself with her teleplastic productions." Is it scientific to describe what might have been a handkerchief as a "teleplastic production"—at all events, until it has been proved not to be a handkerchief? We learn, however, that the interest of the highest possible advancement of the phenomenon is greater than the constant diversion of the medium's attention towards the control, *as such control hinders the rational development of the phenomena and reduces the efficiency!* This view of the pernicious effect of control doubtless accounts for the fact that the Baron made no strenuous efforts to clear up doubts which arose in his mind when he noticed on one occasion that a flat lifeless structure resembling a lady's glove had replaced the band of the medium which was supposed to be on her knee. When the medium had reached the stage of producing pictures of faces, the Baron argues that they could not have been ordinary photographs. He fails, however, to bring into juxtaposition with this inference the fact that Mme. Bisson had a studio and was something of a sculptor. With regard to one of the pictures which showed numerous rectangular creases, as of paper unfolded, the author remarks that "anyone who does not realize the rigorous precautions taken must necessarily assume that a packet was fraudulently introduced." But the Baron airily remarks: "So long as no such trick is actually performed under the same conditions . . . the discussion of the hypothesis 'of conjuring' seems superfluous." On another occasion the discovery on the floor of some small white particles, giving the impression of small balls of paper crushed with a shoe, is discussed as not seeming to have any connexion with the "phenomena." During most of the séances the medium is stated to have been in a hypnotic trance. This may be so; but it seems curious that while still in such a state of trance the medium should be able to come forward at the end of a séance, take off her tights, and ask for a "gynaecological" examination! However, this is a matter which we must leave to those experienced in hypnotism.

It seems to us that Baron von Schrenk Notzing effectually puts himself out of court as a scientific observer. Had he been content to refrain from all allusion to the martyrdom of mediums; had he not made clear from the outset his belief in teleplasma; had he merely recorded strictly the impression on his sense of vision of the manifestations even to the dreary length of this book; had he not tried to invent explanations for such things as the pinholes in the curtain and the paper-like apparitions; had he tried to

revise methods for discovering the origin of the pinholes and the paper creases—had all these things happened, it might have been possible to treat his book with some respect. As it is, the production is a reproach to any man calling himself a scientist, for it neglects every condition of true scientific investigation. Instead of inquiry we have assumption; instead of impartial statement of observation we have a prejudiced attempt to fit the phenomena into a belief. When one of the investigators present at some séances ventured to state that everything was trickery, the Baron tersely remarks, "On account of this negative attitude Dr. Specht was not invited to further sittings."

Our object in dealing at such length with this book is to protest against the assumption of scientific method when no real trace of such method exists. Baron von Schrenck Notzing compares the present position of mediumistic investigation with the position in the distant past of astrology in relation to astronomy and of alchemy in relation to chemistry. But he cannot have it both ways. Scientific method has advanced considerably since the days of astrology and of alchemy. If the Baron's science has not advanced beyond the stage of astrology and alchemy, he should not lay claim to scientific method, which is something far different from the method of the astrologer and the alchemist. We recall again the names of the eminent men of science with which we began. It is excusable that an imaginative novelist should permit himself to swallow any tale of the marvellous that may be presented to him. But that men of eminence in the scientific world should delude themselves into supposing that their observations of mediums resemble in the remotest degree the methods of science is deplorable. Whether mediumistic powers exist or not, the investigation of those pinholes in the black curtain should certainly precede the elaboration of "teleplastic hypotheses."

SURGERY.

HEY GROVES'S *Synopsis of Surgery*² is so well known that it needs no introduction when, as a new edition, it makes its bow for the fifth time. This alone is sufficient proof that there is a need for a book of the kind, and if one must have a "cram" book, then this is just about as good as it is possible to have. We believe its popularity to be deserved. The previous edition was reprinted three times during the war, and the author has taken advantage of a new edition to incorporate in the text some of the more important lessons the war taught. Knowing Mr. Hey Groves's predilections as we do, it does not surprise us that the chief additions have been made to the section on fractures. The section dealing with blood transfusion is good, the choice of donors and technique being well covered in a very condensed but lucid form. In a book of this type any surgeon particularly interested in a special subject will easily be able to find fault. It is not intended to be a book for specialists, but on the whole we believe that the information which it gives the student is sound. A few line drawings are added to the new edition, and the surface anatomy figures have been partly coloured.

Mr. IVOR BACK and Mr. TUDOR EDWARDS contribute the book on *Surgery*³ to the "Students' Synopsis Series" of Messrs. J. and A. Churchill. The work is intended to help the student to revise his work and not to supplant his textbook. It is addressed to the less industrious student, and it is possible that he may find it useful.

Dr. ARCHIBALD McDONALD, of the Johns Hopkins University, is to be congratulated on his *Essentials of Surgery*⁴—a volume intended for probationers and nurses, and in most respects a thoroughly good book. The whole ground is well covered, and the descriptions of the various diseases which come within the purview of the surgeon are clear and concise. The nurse whose privilege it is to listen to a course of lectures based on this manual will be fortunate. At the end of each chapter is a list of suggestions for

illustrating the chief points under discussion. They evidently do these things thoroughly in the United States, for we note that after the lecture on the abdominal cavity we are advised to demonstrate the mesentery, omentum, and serous layers "on anatomical chart or laboratory animal." The method of teaching of nurses by means of selected cases and case histories is admirable and should be employed widely. The only drawback to the book is its extremely "dry" appearance, due entirely to the arrangement of the type on the page and the kind of paper used. There is a valuable glossary at the end.

SYPHILIGOLOGY.

IN the second edition of Dr. LLOYD THOMPSON'S *Syphilis*,⁵ the subject has been brought thoroughly up to date. It has, moreover, been treated in a comprehensive manner, for, as the author states in his preface:

"Syphilis is no longer to be considered a genito-urinary disease, nor a dermatological disease, nor a disease belonging exclusively to any specialty, but is to be thought of as a disease requiring knowledge in all fields of medicine."

The question of visceral syphilis, which did not receive much notice in the previous edition, has been amplified, and an excellent bibliography of the literature of the subject is appended for the use of those requiring further information. In order to render the work as practicable as possible, special attention has been given to diagnosis and treatment. The chapter on laboratory diagnosis has been enlarged, for laboratory aid is more important for successful treatment in syphilis than in any other disease. We regret that the description of the technique employed in the examination of venereal sores for the presence of the *Treponema pallidum* has not been rendered still clearer by the addition of diagrams and micro-photographs. Although illustrations are given of the organism of syphilis demonstrated in the tissues by means of various staining methods, there are no plates to assist the reader in distinguishing the *Treponema pallidum* from similar organisms under dark-ground illumination. Chapter VII contains a full description of complement-fixation tests and other aids to diagnosis. Since writing his previous edition the author has apparently lost faith in the luetin reaction.

Chapter IX deals with the disease from the public health point of view. In the author's opinion education should not stop at the teaching of the dangers of venereal disease, but should include dissemination of knowledge of methods of personal prophylaxis.

"Free prophylactic stations for both men and women should be established and thoroughly advertised in all cities, where not only prophylactic remedies may be administered, but instruction in the methods of prophylaxis and prescriptions for the necessary materials be furnished."

With the objections of the moralists against such an arrangement he has little patience, believing that the fact that the disease is as likely to affect the innocent as the guilty is sufficient justification for adopting any methods of prevention likely to meet with success. Useful sections are included on the important subjects of standards of cure, and of syphilis and marriage. In the paragraph dealing with the latter the dictum is laid down that no permission to marry should be given unless the Wassermann reaction is negative. The complete absence of clinical symptoms over an extended period is, in the author's opinion, insufficient justification for marriage with a positive Wassermann reaction.

Dr. Thompson is an advocate of intrathecal medication in all cases of neuro-syphilis. The technique he employs is a modified Ogilvie method, the injections being given at intervals of seven to ten days.

"The intraspinal treatments should be continued until the spinal fluid becomes negative, or, in the case of paretics, for eight or ten injections if no objective or subjective improvement is noted. . . . If intraspinal treatments do not relieve cerebral symptoms, intracranial, either subdural or intraventricular injections, should be given a trial. No case of syphilis, from the chancre to paresis, should be given up until all means of treatment are exhausted."

²*A Synopsis of Surgery*. By E. W. Hey Groves, M.S., M.D., B.Sc. Lond., L.R.C.S. Eng. Fifth edition. Bristol: John Wright and Sons, Ltd. 1920. (Cr. 8vo, pp. 623; 13 plates, 21 figures, 17s. 6d. net.)

³*Surgery*. By Ivor Back, M.A., M.B., B.C. Camb., F.R.C.S. Eng., and Tudor Edwards, M.A., M.C. Camb., F.R.C.S. Eng. Students' Synopsis Series. London: J. and A. Churchill, 1921. (Cr. 8vo, pp. 488, 15s. net.)

⁴*Essentials of Surgery*. By Archibald McDonald, M.D. Philadelphia and London: J. B. Lippincott. (Pp. 265; 46 figures.)

⁵*Syphilis*. By Lloyd Thompson, Ph.D., M.D. Second edition, thoroughly revised. 1920. Philadelphia and New York: Lea and Febiger. (Med. 8vo, pp. 205; 81 figs., 7 plates.)

The book concludes with chapters on congenital syphilis. Altogether it is a remarkably complete work, and one in which practical matters, rather than points of academic or historical interest, have been emphasized.

NOTES ON BOOKS.

WILLIAM SUTHERLAND, whose interesting biography has been attractively sketched by the Professor of Physiology in the University of Melbourne, Dr. W. A. OSBORNE,⁶ was an independent worker in the realm of advanced physics and never held any professorial chair. The great majority of his sixty-nine contributions to scientific literature, given in an appendix, are on physical problems, and many of these appeared in the *Philosophical Magazine*; but there are some on physiological subjects, such as the rate of the propagation of the nerve impulse, the chemistry of globulin, and the heat coagulation of protein. In addition, he did much to popularize recent science by writing in the lay press, and thereby advocated wise reforms in many directions, such as education, the position of women, abatement of the dust and smoke nuisances, and the beautification of Melbourne and the Yarra. Unfortunately he did not live to see the electrification of Melbourne's big suburban traffic, of which scheme he has more claim than any politician to be called the father, nor the utilization for power of the huge deposits of Victorian brown coal which his mental vision clearly foresaw. Possessed of an encyclopaedic knowledge, he was characteristically modest and honest; thus he refused all honours, and when approached for his assent to be nominated for the Royal Society, he sent the rather disconcerting reply that the proceedings and transactions of the Society were available in Melbourne, and that he was unaware of any other advantage attaching to the Fellowship. In face he somewhat resembled Tyndall, and was usually much sunburnt from exposure in the bush, in which he delighted. He chose a small income and an independent position, and after his sudden death his biographer comes to this conclusion: "Among the saints of science high place will assuredly be found for William Sutherland."

Dr. R. S. CARROLL'S *The Soul in Suffering*⁷ contains five-and-twenty chapters written, as the author tells us in the preface, "with a constructively sympathetic understanding of the soul-need which comes to the suffering." Here the reader will find lay sermons, the commonplaces of consolation, set out with a magniloquence of philosophical and orotund verbiage, reinforced with quotation, analogy, and inextinguishable optimism. The book will doubtless find many readers, and should prove more helpful to sufferers than even the blessed word Mesopotamia.

⁶ *William Sutherland: A Biography*. By W. A. Osborne. Melbourne: Lothian Book Publishing Co. 1920. (Cr. 8vo, pp. 101; 4 illustrations. 7s. 6d.)

⁷ *The Soul in Suffering*. A Practical Application of Spiritual Truths. By Robert S. Carroll, M.D., Medical Director, Highland Hospital, Asheville, North Carolina. New York: The Macmillan Company. (Post 8vo, pp. 241. 8s. 6d. net.)

ASSOCIATION OF CERTIFYING FACTORY SURGEONS.

THE Council of the Association of Certifying Factory Surgeons has recently drawn the attention of the Chief Inspector of Factories to two matters which are considered to be of considerable importance to certifying surgeons.

The first is the circumstance that, in connexion with the two last annual reports, they have not been asked to include any particulars respecting the allowing of conditional employment (Section 64 (5) F. and W. Act, 1901), but have simply been required to give details respecting "rejections." Section 122 (6) F. and W. Act, 1901, requires a record of all young persons ascertained by medical examination to be physically defective, and of the action taken by the certifying surgeon with respect to such. The word "results" is used, and as this signifies more than rejections, it is held that a return confined to these cannot cover the obligation. The system of conditional certificates, in spite of its imperfections, is regarded as having greatly extended the usefulness of the certifying surgeon, and as being of proved benefit to large numbers of young people on commencing their industrial career. Apart, therefore, from the strict legal requirement, it is

considered of public interest that a full record of the "results" of factory medical examinations should be available. It has been pointed out that the action taken by the certifying surgeon, as a result of the defects found, depends, as a rule, more on the nature of the industry and its capacity for providing suitable alternative employment than on the nature of the bodily disease or infirmity *per se*, so that any particular defective may be totally rejected at one factory and certified conditionally at another; that the bulk of defectives may be regarded as of one class, dealt with in two different ways according to varying circumstances; that the incomplete return at present asked for cannot possibly give any idea of the discrimination exercised in dealing with these young people, and is therefore unfair to the surgeon as well as misleading to the public. Whilst the former publication in the Chief Inspector's annual reports of a complete summary of conditions attached to certificates of fitness is regarded as having undoubtedly served a useful educative purpose, in view of the labour entailed in compiling the table, the association does not press for its renewal. On the other hand, the Council suggests that a full classification of all those found affected with disease or bodily infirmity should be published under two divisions—namely, (1) rejections and (2) certified conditionally.

The second point is what the Association of Certifying Factory Surgeons considers to be the incomplete and unsatisfactory methods adopted in the effort to secure adequate first-aid treatment of the injured in those factories and workshops where provision for such is obligatory. The Council is convinced that no arrangements can be considered efficient unless placed under some system of regular medical supervision. It is the opinion that a satisfactory control of first-aid and ambulance arrangements could be readily obtained by making it an obligation upon the employer to obtain from the certifying surgeon—every three months in the case of works employing 500 hands or over, and every six months where under 500 are employed—a certificate to the effect that the provision made is suitable and sufficient. The Chief Inspector has been asked to consider the advisability of authorizing a medical representative of the department to discuss this matter with expert representatives of the association with a view to some practical scheme being evolved.

NOTE-TAKING IN GENERAL PRACTICE.

[FROM A CORRESPONDENT.]

IN reply to one who had expressed some dissatisfaction with the opportunities offered by general practice for the study of disease, and envy of the opportunities of the specialist, Sir William Gowers wrote:

"Cases which come under the notice of the physician and are instructive in detail are very few compared with the immense number which are seen only by practitioners, and the opportunities these present are wholly lost for want of a little careful note-taking and the knowledge of what to observe. Moreover, practitioners have the opportunity of doing what no one else can—following up cases and observing their course. This is of extreme importance after careful record."

This opinion is worth as much to-day as it was when given twenty-five years ago, for no one will dispute that careful note-taking is essential for both the science and the practice of medicine; it is valuable not only to help the attendant's memory, but to save his time. How much quicker to learn, how much more accurate, a patient's medical history that was recorded at the moment by the medical man in attendance at previous illnesses, than what can be dragged out or sifted from what pours out of a patient's memory of his past miseries.

And what is the time occupied in taking these notes? No more than that required to make the necessary careful inquiries; and the busier one is the more need is there to take notes, because with the rush of patients it is more difficult to remember the details of each case and because when one has previous notes to refer to less time need be taken in catechizing the patient. If there is not time to take notes, there is not time to see patients properly, and something is at fault either with the method or the means.

The Value of Records.

Any medical man who has kept the simplest notes of his cases must realize their value to himself, and conversely, how often must many have longed for such a record however brief!

It is suggested that notes such as the busy general practitioner can take will themselves be valueless, because it is not possible to name accurately most illnesses, that they will merely be notes of signs or symptoms and not interpretations of them, but surely this will be their true value. Clinical notes that are statements of fact must have greater scientific value than mere opinions: they will be of value not for adding up in rows, but for reference, research, and discussion. Even the interpretations of these signs and symptoms, under the heading diagnosis, will be of value if we realize that the term used represents not a disease but a condition.

It should be realized that the value of a clinical history often lies in the collection of many small details rather than in the record of any one big event; one small detail may be sufficient to make the evidence complete. Without the correction supplied by such records of fact, ill-founded opinions are apt to grow in a man's mind and to prejudice his views. The making of a note, however simple, if one has in mind at the time that the object of that note is future reference and help for one's self or someone else, must tend to make one think more and take more care; true it is often by no means an easy matter to find words in which to express symptoms and opinions, but the habit of doing it frequently and having to do it carefully should in time develop a better practice.

The special value of a general practitioner's record lies in the fact that he alone can see the whole of a disease from the very beginning, knows the conditions that existed before the beginning, and knows the life-history of the patient; he sees those beginnings of disease that, contrary to expectation, do not develop beyond a certain stage; he sees those diseases that are not fatal, though according to precedent they should be, and those conditions that develop into serious and fatal diseases when they are not expected to.

Note-taking and Research.

There are two types of clinical research, and the note-taking required for each is different. There is that advanced and detailed research such as is carried on at the St. Andrews Institute for Clinical Research under the direction of Sir James Mackenzie, which requires specially apt and trained observers. The other is that which may be conducted by the general practitioner.

In a report of the Medical Research Council (BRITISH MEDICAL JOURNAL, January 15th, 1921, p. 91) occur these words:

"There are many problems in medical science which can best be studied, and some indeed which can only be fully studied, the Council believes, by men engaged in professional practice, who are in a position to follow the signs and results of disease and the effects of given treatment in suitable cases from their earliest to their latest phases. Studies, however, of this kind can only be successful if the professional man has some leisure and if he has access at need to laboratory and other resources, like those of a well-equipped hospital."

If these words do not apply to the family doctor, I do not know to whom they can. True the last sentence is not appropriate to the average general practitioner of to-day, but the Ministry of Health, or at any rate its Medical Consultative Council, has by its interim report shown the way and the desire to provide this opportunity for the general practitioner.

However, though much investigation can only take place in the conditions pertaining to an institution, it is important that disease should be studied in what one may call its natural surroundings, otherwise we cannot estimate properly the influence of these surroundings, and unless we know how this influence affects cause and progress, we cannot hope to find the means for prevention and cure.

This general practitioner type of investigation is of great, though varying, value; a medical man must, from his training, be competent to take notes, but practice and experience, interest and appreciation, will increase the value of his work. Whatever he may have been taught in hospital by his clinical lecturers, he yet must learn for himself the methods best suited to his practice, and he may learn much by comparing, when opportunity offers, the methods adopted by others.

The last thing wanted is a stereotyped method; that system and method will be the best which has gradually developed by a process of evolution and selection. Though in note-taking all depends on the "how," it will always be of prime importance to select the essential and the potentially useful. Facts must always be of more value than opinions, though the latter will often be worth much; the difficulty is to differentiate the opinion that is the result of long and careful observation and deduction from that which is founded on prejudice, inaccurate observation, and insufficient knowledge.

A mere statement of an incapacitating cause such as will do for a certificate of inability to work is not likely by itself to be of much value as a clinical note: the ideal clinical note will, if possible, contain something to indicate the pathological condition, the part affected, and the cause. For instance, "indigestion" by itself will not be very valuable, but "epigastric pain two hours after food," may be useful. Compare "rheumatism" with "arthritis, left knee, traumatic," or "arthritis, right wrist, wasting muscles hand and forearm, carious teeth."

The note-taking habit will surely be an incentive to all sorts of investigations, and it is very likely to stimulate particular interest in one or more special subjects, leading the way to that ideal specialism which is the outcome of special aptitude, interest, and opportunity, in a practitioner experienced in all branches of his work. Those specially interested in any particular part or parts of their work might with advantage keep a small subject index.

Records for Investigation.

Records as to the results of some treatment would often do much to prove its use or uselessness and to prevent those generalizations which are so frequent and harmful, and exaggerated deductions from a few failures or a few successes. How useful, for instance, would be a record of every case of thyroid disease—the early history, heredity, water supply, progress and result of various treatments; every general practitioner in some neighbourhoods would in a few years have a wonderfully interesting collection, and if he and his neighbours would one day collate and compare these notes and deductions, they could hardly fail to draw up a valuable report. Or supposing that the carefully recorded life-histories of a large number of cases of cerebral haemorrhage were examined, how interesting and possibly surprising might be the findings as regards their relation to heredity, diet, dental defects, blood pressure, kidney disease, surroundings, and occupation. What opportunities there would be for learning more of the early history of phthisis, or the after-history of the so-called pre-tuberculous patient. Again, statistics of a sort might well be considered, such as the duration of incapacity from certain diseases and accidents, and the effect of surroundings on that duration of incapacity.

A medical man who notes the signs, symptoms, and treatment of his cases and their sequels at intervals during the patient's life, will accumulate a mass of facts for consideration and discussion with other men who have done the same, and with men who have made special study of particular diseases. It would not only add interest to work, but greatly increase its value, if this were done more or less systematically.

The members of a medical society or of a Division of the British Medical Association, might arrange a series of subjects of general interest which they would discuss at given dates—say in two, three, or four years' time, or even at longer intervals—one or two subjects being chosen for each year. Or such a scheme might be widened in its area and applied not to one or two medical societies only, but to the whole of England; and at suitable intervals, after consideration at various local meetings, these subjects might be discussed centrally at the Royal Society of Medicine, or the annual meeting of the British Medical Association.

There are all sorts of questions having local interest that might be considered, not only the life-history, causes and treatment of different diseases, but the incidence of disease as affected by occupation, general conditions, heredity, etc. Such consideration, based, of course, on the records made by those taking part, would take place first by individuals and then by groups. This would add much interest to the medical man's life, raising what may be mere drudgery to a delightful occupation; no doubt we might have to wash much gravel to find a few diamonds, but the reward is worth the work.

Sir John Lubbock wrote: "The most important secrets of Nature are often hidden away in unsuspected places; many valuable substances have been discovered in the refuse of manufactories." Twenty thousand medical men in daily practice; what an enormous amount of clinical evidence and experience they must have! We need give all our thought, not to preventing its preservation, but to devising means to make the best use of it.

At the Third International Labour Congress, to be held at Geneva in April, the following medical subjects will be discussed: Protection against accidents, sickness, and old age; disinfection of wool contaminated by anthrax bacilli; prohibition of the use of white lead in the painting industry; prohibition of the employment of persons under 18 as firemen or stokers, and obligatory medical examination of children working on board ship.

British Medical Journal.

SATURDAY, MARCH 19TH, 1921.

THE NEW EPIDEMIOLOGY.

We recently summarized the report of the Ministry of Health upon the pandemic of influenza, and it may interest some of our readers if we attempt to characterize certain ways of thinking which parts of the report illustrate.

A few years ago Dr. Hamer, more in anger perhaps than in sorrow, identified epidemiology with the Sleeping Beauty and bacteriologists with the authors of the spell. This, no doubt, was to go a little too far; the Sleeping Beauty has never been actually comatose; Dr. Charles Creighton was applying stimulants even before Dr. Hamer took the case into his very efficient hands. Yet it is at least certain that, down to a very recent date, the bacteriologist's views upon the etiology and prophylaxis of epidemic diseases were regarded in all the "best circles" as of much greater importance than the views of any other medical or non-medical investigators. Even now a considerable majority of medical men and nearly all laymen are realists. They demand to be shown something on a plate—a Petri plate—and to be told "this is the germ which causes the disease." The next step is either to exterminate the germ or devise an antidote. This step having been taken, the epidemic disease—by definition due to the germ—is, or ought to be, of only historical interest.

But orthodoxy has now to reckon with heretics. As generally happens, the heretics won their first successes through the mistakes of the orthodox and in virtue of their own audacity. On the one hand bacteriological realists drew too many bills on futurity which were not honoured on presentation, and again they did not always *seem* (as Dr. Hamer was never weary of pointing out) to agree perfectly one with another. On the other hand, they ruffled the feelings of a small but pugnacious group of statisticians, who, having acquired a technique at least as mysterious, and therefore awe-inspiring, as that of the immunologist, declined to be snubbed. The consequence is that a "new" epidemiology if still schismatic has at least some chance of acquiring orthodoxy. At first blush this new faith is not attractive; it is so easy to parody. The outraged realist proclaims that one of the "new" epidemiologists believes influenza to be not only influenza but everything else, and holds that a sufficient answer to criticism is to invoke the name of Sydenham with rapture; that another sees life as a monomolecular reaction and disease as terms of a Fourier expansion; while a third, emulating Hudibras and able to

"Resolve by sines and tangents straight,
If bread or butter wanted weight;
And wisely tell what hour o' th' day
The clock does strike, by Algebra,"

is still not quite sure that anything has been added to knowledge (except by statisticians) since Galen.

But it would not need the author of *The Elephant in the Moon* to handle the orthodox school at least as severely. While, as we have surmised, the opportunity of the "new" epidemiologists was afforded them by the over-confidence of the old epidemiologists, it is due to something more that they maintain, and

seem likely to extend, their ground. They all, whether they deal in terms of medical history, of physical chemistry, or of coefficients of correlation, agree in two fundamentals. The first is that it takes something more than a bacillus to bring into being an epidemic disease. The second is that those other factors, whether inherent in the structure of man or implicit in his environment, are capable of measurement and their conjoined effects capable of prediction. It is an easy thing to sneer at the man who loves to pore over the books of those who died in ignorance of our modern lights. It is easy to rail at the attempt to number and count the phenomena of life and to laugh at presumption which will essay to foretell the succession of diseases:

"How do they call him? The sagacious Swede
Who finds by figures how the chances prove,
Why one comes rather than another thing."

But it has been by these means that all other sciences have developed, and we cannot doubt that in this way also knowledge of epidemiology will pass from a crude empiricism into a branch of exact science. No grosser mistake can be made than to confuse the familiar with the known. The relation between poverty and disease is familiar, but it is not known. For these and many other reasons, the attempt of the "new" epidemiologists to collect materials for the compilation of an exact natural history of disease, not narrowly restricting their field nor inquiring too particularly as to the specific differentiae of the disease, is, we believe, well directed. To resume the task of Sydenham armed with the tools which more accurate means of collecting and analysing data provide, is not a work of supererogation.

FINE ADJUSTMENTS.

IN his Association lecture to the Edinburgh Branch, published this week, Dr. Haldane recurred to a doctrine a particular application of which he had briefly discussed in a lecture printed in our columns of July 19th, 1919. In that lecture, dealing with the causes, symptoms, consequences, and prevention of anoxaemia—a condition in which the supply of oxygen to the tissues is insufficient—he marvelled at the extraordinary fineness of the adjustment determining the degree of activity of the respiratory centre. As he then pointed out, the haemoglobin in human arterial blood is nearly saturated with oxygen; in addition to this chemically combined oxygen a very small amount is present in free solution in the blood, and as the blood passes round the circulation this free oxygen is continuously given up to the tissues and replenished at the expense of the oxyhaemoglobin, the latter recovering its full complement in the lungs. In order that the normal state shall be maintained, the respiratory centre must be in a state to respond to its normal stimuli, the breathing must produce sufficient ventilation of the lung, the alveolar epithelium must be in good order, the circulation must be effective, and the haemoglobin normal. Investigations made during the war showed that irregular distribution of air in the alveoli, owing either to shallow breathing or to irregular obstruction of bronchi, was an important cause of anoxaemia; though some alveoli are over-ventilated, others are under-ventilated, and the net result is that the mixed arterial blood is insufficiently saturated with oxygen. The anoxaemia, not only of bronchitis, of emphysema, and of cardiac disorders, but, it would appear, of pneumonia also, is mainly due to this irregular distribution of air in the lungs, a fact which accounts for the

striking effects of the continuous administration of oxygen in the manner described in the earlier lecture. It explains also how it comes about that on the occurrence of the crisis in pneumonia the rapid shallow breathing ceases, though the consolidation remains. It might have been supposed that arterial anoxaemia must result from a large amount of venous blood passing through the consolidated lung without being oxygenated, but, as the clinical observation last mentioned indicates, and as Professor Meakins has shown by x-ray photographs of injected lungs in pneumonia, the circulation in the consolidated parts is almost entirely blocked.

The main topic of Dr. Haldane's Edinburgh lecture, however, was, as has been said, the quite extraordinary accuracy of the adjustments in the living body. He illustrated this further by a relation of some recent observations on the regulation of the renal excretion. The kidneys like the lungs regulate the composition of the blood. When a large quantity of water is ingested the response of the kidneys is so immediate that if the body is already fully supplied with water, only an extremely small dilution of the blood is produced—a dilution so small that special methods of great delicacy must be used for its detection. By withholding water the excretion of urine is diminished, and the body weight may thus be reduced by several pounds; when water is again taken freely the body weight rises, but so soon as the normal is reached any more water ingested is promptly excreted. There is thus a well defined normal threshold for water in the blood beyond which it is excreted; the use of the word "threshold" to express the stage or level at which some change occurs is happy and its application to the ratio of water in the blood picturesque. A threshold may be raised or lowered by disease, and the modern treatment of diabetes depends largely upon the recognition of the fact that the threshold for sugar which has been lowered may, by suitable dietetic treatment, again be raised. So also in respect of the maintenance of the alkalinity of the blood there is a very well defined threshold below which acid urine is excreted, while above it the urine is alkaline. It is easy to see how ideas of this order will help to an understanding of what is happening in disease, and, it may be hoped, to more effective treatment.

Some of the observations on the regulation of blood composition related by Dr. Haldane have not hitherto been published, and they will, we believe, be read with great interest. He and Dr. Douglas devised a method of investigating the gases of the mixed venous blood returning to the heart in man; by its use they found that during complete rest mixed venous blood is not only very steady as regards its gas content, but considerably less venous than has hitherto been supposed. They found also that the rate of the general circulation is faster than formerly calculated, so that a volume of blood equal to that in the whole body passes through the heart about every thirty-five seconds, or nearly two gallons in a minute. The manner in which the amounts of oxygen and carbon dioxide present in the general venous blood are maintained at constant levels is another striking example of accurate regulation.

We are so familiar with the fact that it is the nature of a living organism when deranged to return to the normal that we have ceased to wonder. If we see it in the striking adjustment which immediately takes place on over-exertion we see its slower operation in disease; it is, in truth, the *vis medicatrix naturae*. The investigations Dr. Haldane describes help us to understand how this healing force acts, and therefore how Medicine can hope to remove

obstructions out of its way, but they do not explain what that force is. We cannot now attempt to follow Dr. Haldane in the speculations lightly referred to in his lecture and more fully set out in his recent book.

LORD MOULTON OF BANK.

LORD MOULTON, known far and wide when Mr. Fletcher Moulton as a great patent lawyer, died in his sleep after a busy day on March 8th, in his 77th year. He became a judge of the Court of Appeal in 1906, and Lord of Appeal in Ordinary in 1912, in which year he received a life peerage; for his services during the war he received the K.C.B. in 1915, and the G.B.E. in 1917. He was a Fellow of the Royal Society, and the distinction was not merely complimentary. We are indebted to Sir Walter Fletcher, F.R.S., Secretary of the Medical Research Council, for the following estimate of Lord Moulton's great service to science: The biographical notices of Lord Moulton of Bank which have recently appeared in the press have hardly done justice to his scientific abilities, and have almost wholly failed to recognize his personal contributions to the welfare and progress of medical science. No doubt this is to be explained in large part by his sudden and wholly unexpected death, which allowed little time to current journalism for the examination of the public and private work he did in scientific fields outside his long and distinguished professional career during peace, and apart from his special services to the country during the war as Director-General of Explosives Supply. Yet the lustre of his more familiar achievements at the Bar, on the Bench, and in the Ministry of Munitions, should not be allowed to obscure the brilliance of the service he gave at every opportunity to the best interests of British medical science. He followed with close interest all the chief developments in the growing branches of physiology and pathology that contribute to medicine, not in vague and desultory admiration, but in steady pursuit and appreciation by a mind subtle, highly trained, and well stored. For the intellectual pleasures thus received he repaid the general cause of medical research by numerous and willing services of his own. Any science must gain if it has the steady sympathy of a man filled with expert knowledge of its methods, its results and its needs, who occupies a high public position. Few public and powerful men have even elementary knowledge of any natural science, and fewer know the roads by which all sciences advance. Lord Moulton in unnumbered ways was able to help the medical sciences by his advocacy and his influence, and to enlarge the general appreciation of them. He gave direct help besides to many special medical causes. He was much concerned, for instance, in the development of the inoculation department at St. Mary's Hospital, and Sir Almroth Wright has acknowledged his debt to Lord Moulton for some at least of the "phylactic" terminology now current in the study of the protective responses of the body to invasion. In particular it will be remembered how valuable and widely effective was the evidence given by Lord Moulton before the Royal Commission upon animal experiments—perhaps one of his most brilliant pieces of pleading. In this he irresistibly exposed the essential cruelty of those who, by opposing animal experiments, were impeding the diminution of the total sum of animal and human suffering. It was largely in recognition of his many services to medical science that he received his honorary doctorate at Cambridge on the occasion of the opening of the new School of Physiology by H.R.H. Prince Arthur of Connaught in 1914. In 1913 Lord Moulton was appointed to be the first Chairman of the Medical Research Committee (now Council), and he held that office until 1916, when he was led to retire by his increased duties in the Ministry of Munitions. He maintained up to the last the keenest

personal interest in the work of the Council. During the first critical year of its existence the Committee held weekly meetings in his house, and under his guidance laid down the broad principles upon which that new venture in the relations of science to the State was to be guided. It is well known that he brought to this work by no means only the general authority and support of the lay chairmanship commonly expected from an eminent man set to preside over a committee of experts. His familiarity not only with the content of scientific knowledge, but also with the daily realities of the laboratory and of the ward, greatly enriched and steadily guided his influence. This may perhaps be traced especially in the success with which that early committee approached certain vital problems that seem now in retrospect to be less formidable, perhaps, than they were at that time and until the war had brought home to the country the place and power of which research work should have been possessed long before. Among these may be mentioned the problems of obtaining reasonable security of tenure for scientific workers, and Ministerial approval for it, when the only available funds had nominally only an annual sanction; or, again, of widening the scope of reference to "medical research" so as to include that work in primary sciences for which much of pathology waits in need, and from which strictly utilitarian results in the long run may be expected with more confidence than from direct frontal attacks upon particular morbid processes by *ad hoc* research. For all these services of his to medical science, though they were but the parerga of a crowded and laborious life, the medical profession must always lie in heavy debt to Lord Moulton. Personal dues of affection and regard are owed to him by many individual members of the profession and by many scientific workers, who drew encouragement and inspiration from the subtle play of his critical insight, given freely in private talk or emerging with easy opulence among the catholic charms of his remarkable conversational powers, never shown more effectively than in the circles he delighted in drawing together to enjoy his genial and unmeditated hospitality.

AIR AMBULANCES.

IN the JOURNAL of December 13th, 1919 (p. 785), we recorded the views of the famous French surgeon, M. Tuffier, on the value of aeroplanes in military surgery, arising from his experiences on a professional visit to see a wounded French general in Southern Morocco. The patient had been brought by aeroplane for surgical treatment from a distant outpost over the middle Atlas mountains and over regions occupied by hostile tribes to a hospital in a large military station. In the south of Algeria and Morocco and in the Sahara the French army, owing to the conditions of the country and the nature of the military operations, had been led to make considerable use of aeroplanes for the transport of the wounded also. M. Tuffier was shown a machine specially constructed for conveying two wounded men, but it was not found very satisfactory, owing chiefly to the difficulty of lifting the patients in and out of the fuselage. The French military authorities have been giving careful study to the designing of special aeroplanes for transporting wounded, which would be of particular value in such frontier operations as those in their African territories. The Canadian Army Medical Corps also made some experiments in designing a similar aeroplane, but we have not seen a report of their result. Nearly three years ago the Medical Department of the United States Army undertook to prepare plans for the construction of air ambulances. Messrs. Vickers, Ltd., have now, we learn, constructed an aeroplane ambulance, modified from the "Vickers Vimy Commercial" type of aeroplane, which seems to be a great advance on anything that has previously been achieved. This machine is capable of carrying a crew of two, two attendants (for

instance, one doctor and one nurse), and four stretcher cases or eight sitting cases, at a speed of 109 miles an hour for five hours, without a stop. Two Napier "Lion" engines of 450 horse-power each are installed, and all parts of the aeroplane, other than the fuselage, are interchangeable with the ordinary service type "Vimy." The two pilots are accommodated side by side in the pilots' cockpit in the nose of the aeroplane. The stretchers are fitted on one side of the cabin so that there is adequate clearance space, and the stretcher racks can be folded up out of the way when seating accommodation is required. Medical equipment up to 105 lb., stores to 200 lb., and a water tank for medical purposes holding 165 lb., are also carried, as well as the engine necessities. A wireless equipment is provided; there are special cooling arrangements for tropical climates, and adequate lavatory accommodation is provided. Under the pilot's seat in the front of the cabin there is a door which allows of the loading and unloading of the stretchers, so that the possibility of congestion, and turning of corners and similar rough treatment of the patients, is eliminated, while further door space is provided for rapid evacuation in case of emergency. The lessons of the "side-shows" of the great war must not be forgotten, and in the military reorganization of our African colonies, Mesopotamia, and India there is a wide field for the employment of ambulance aeroplanes, which could effect large economies by cutting down the number of outlying military hospitals at present necessary. The excellent photographs of the Vickers aeroplane ambulance that we have seen suggest that it provides a most comfortable, even luxurious, mode of transport for the wounded.

TRYPANOSOMIASIS RESEARCH.

DIFFERENCES of opinion which existed with regard to the means which could be taken to check the spread of trypanosomiasis in Africa led the Colonial Office to appoint a Departmental Committee, which reported in May, 1914. The Committee agreed that the proposed experiment of removing wild animals from a selected area might produce valuable information, both as regards the habits and the extent of the infectivity of the fly, and the degree of infection of man or stock derived from wild animals. The Committee, however, laid more stress on the need for further investigation. The outbreak of the war prevented any action being taken on this report, but the increase of sleeping sickness in certain of the French equatorial colonies and also in the Belgian Congo led the French Société de Pathologie Exotique to appoint a committee under the presidency of M. Laveran. The report of this committee, which was adopted by the French Colonial Minister, attached particular importance to the administration of atoxyl, with the object of destroying the flagellates in the blood of all infected cases. This, it was recognized, would involve a large personnel in all infested districts to detect and treat the infected. Though the extermination of glossina was regarded as impossible, it was thought that something could be done to remove the natives from areas chiefly frequented by the fly and to protect them against bites. At home the Secretary of State for the Colonies applied to the Imperial Bureau of Entomology, which appointed a special Glossina Subcommittee. The report of this committee begins by observing that the tsetse flies of the *Glossina morsitans* group range over very wide areas of tropical Africa. In Southern Rhodesia, where the fly-belts are comparatively small, their extent has been estimated at 9,000 square miles. In Northern Rhodesia it would, it is said, be difficult to find a continuous area of fifty square miles free from *G. morsitans*, except on the plateaus. Probably more than a fifth of Nyasaland is infested by tsetse flies, and the fly-belts cover nearly half Tanganyika territory. The need for more knowledge of the habits and life-histories of the flies and of the factors which favour their increase or inhibit their spread is insisted upon; even in

respect of *G. morsitans* there are many important gaps in knowledge, while practically nothing is known about *G. pallidipes* and *G. longipalpis*. Of the methods suggested for the eradication of the tsetse flies, the five principal are: wholesale destruction of the larger mammals; the clearing of all small trees and undergrowth; the continuous capture and destruction of the flies on a large scale; the eradication of natural breeding places, and the provision of artificial ones from which the pupae would be regularly collected, the flies emerging from them being killed and any parasites released in order that they might be bred on a large scale. All these proposals are condemned on the ground that it is impracticable to carry them out effectively over large stretches of country, though they might be effective in limited areas, as seems to be proved by experience in the island of Principe in the Gulf of Guinea. The report emphasizes the necessity for further study of the bionomics of the insects and more thorough surveys of the areas. The report was discussed at two meetings of the Royal Society of Tropical Medicine last autumn. Professor Warrington Yorke, who introduced the discussion, criticized it from several points of view: while he held as strongly as the subcommittee that further investigation was necessary, he pleaded for concentration of effort, urging that the work of entomological, medical, and veterinary research into the trypanosomiasis problem should be combined under one central organization in Africa, and be supported by contributions from all African states interested. Professor Yorke maintained that the personnel of an investigation commission should be large enough to ensure continuity of work, and that it should have sufficient funds to allow of the employment of adequate native labour for investigations on a sufficiently large scale, especially as to the dependence of fly and trypanosomiasis on game. Professor Yorke's views came in for a good deal of criticism during the discussion. Dr. Guy Marshall, one of the members of the subcommittee, maintained that it would be better to establish experiment stations in a number of different parts of Africa rather than to concentrate all efforts in one place; there were at least four species of flies of major importance, and the life-histories of each required further elucidation, as did also the influence of varying local conditions on them. Dr. Marshall also defended the committee for looking at the matter mainly from the entomological standard. The conclusion that the subject must be studied from every point of view, the medical being as important as the entomological, would seem to be the chief outcome of the discussion.

HYDROCEPHALUS IN ACHONDROPLASIA.

THE large head of the achondroplastic has been long recognized as characteristic, forming a vivid contrast with the short arms and legs and stunted stature which complete the picture. *Post-mortem* examinations of the skull have revealed a tri-basal synostosis, resulting in shortening of the cranial base, with consequent brachycephaly and recession of the bridge of the nose. This smallness of the cranial base does not in itself account for the largeness of the head. Dr. W. E. Dandy points out that the enlargement of the cranial capsule is not relative but absolute, the heads of these people being of the hydrocephalic type. He notes that whilst accounts of the architecture of the skull in these cases are not lacking, practically no attention has been paid to the condition of the enclosed brain. It has, however, been noted previously that the intellect of these persons is inversely proportional to the circumference of the skull. Jansen,² whose work on achondroplasia is well known in this country, has actually noted hydrocephalus in two cases. Dandy's interest in the subject was stimulated by a

¹ W. E. Dandy, Hydrocephalus in Chondrodystrophy, *Johns Hopkins Hosp. Bull.*, January 5th, 1921.

² Mark Jansen, *Achondroplasia—its Nature and its Causes*, London, 1912.

patient in the Johns Hopkins Hospital who presented the anomalous picture of a cranium larger than normal but a defective mentality. As almost the only thing which can cause the head to enlarge, and at the same time reduce the mental capacity, is hydrocephalus, Dandy set about obtaining a ventriculogram. He withdrew a quantity of cerebro-spinal fluid by a puncture of the posterior horn of the lateral ventricle, and injected an equal amount of air. Radiography demonstrated an enormously distended ventricle, the picture being one pathognomonic of hydrocephalus. Mental impairment is not universal in achondroplasia, at least in its earlier stages. It is difficult to understand precisely why hydrocephalus should develop in this affection. Dandy inclines to the view that the crowding of the base of the brain causes narrowing of the arachnoid cisternae, or that there may be a kinking of the iter. He admits that this is pure hypothesis, and we must await further investigations.

"AESTHESIOSCOPIA ABDOMINALIS.

A SCANDINAVIAN worker, Dr. T. B. Wernøe, has described a method for detecting areas of hyperaesthesia in the skin of the abdominal wall. The method depends on the observation that when warm skin is cooled it becomes paler owing to reflex vaso-constriction; in the presence of hyperaesthesia this reflex is exaggerated, and an area of hyperaesthesia exposed to the air becomes paler than the neighbouring parts. The difference is not very marked in bright illumination; but if the abdomen is turned away from the light and a little time is allowed for the reaction to develop and for the observer's eye to become accustomed to the dim illumination, the difference between hyperaesthetic and normal areas will be sharply defined. Compared with pinprick methods of testing for hyperaesthesia, this method has, it is said, the advantages of greater rapidity, accuracy, and objectivity. The author reproduces figures showing the shape, size, and distribution of the areas of hyperaesthesia mapped out by his method, and he regards it as applicable to intrathoracic conditions, such as pericarditis, as well as to abdominal and pelvic conditions. Hairy and pigmented skin does not show the reaction well, nor does skin which is much exposed to the air. The author records a fatal case of traumatic ileo-caecal invagination in which the site of the intestinal obstruction was clearly indicated by aesthesioscopia.

INDUSTRIAL WELFARE AND RESEARCH

A YEAR or two ago a number of business men, who were faced continually with the effects of growing unrest and discontent in industry, came to the conclusion that the prevailing spirit was due largely to the lack of the old personal touch between employer and worker. It seemed to them that the industrial welfare movement provided both a valuable means whereby this link of friendship could be restored and a method of removing many of the causes of the trouble by showing to employer and worker alike their many common interests. In order to extend this movement the Industrial Welfare Society was formed, and its policy has been warmly approved by many hundreds of firms in which a better feeling between the workers and employers has been created. The growth of this society has been continuous, but in order to obtain the larger financial support necessary an appeal had to be made to the wider public. A conference on industrial welfare was therefore held at the Mansion House on March 2nd, and speeches were made by the Duke of York, Sir Charles Wakefield, and others. Before, however, there could be recaptured for modern industrial concerns the spirit of co-operation and fellowship that existed in the days of the old craft guilds between master and apprentice, there must be properly conducted research into the practical application of science to the human

¹ *Uses of the Lungs*, November 14th, 1920.

conditions of modern industry. For this purpose has been founded a National Institute of Industrial Psychology, and the first meeting of its Council was held on March 3rd. The chairman, Mr. H. J. Welch, referred to the three branches of the proposed work of the institute—vocational guidance and selection, fatigue research, and movement study—the purpose of all three being the elimination of human waste and friction. The application of scientific knowledge to the human factor in work should not only increase production at low cost, but also add to the happiness and contentment of mankind. Mr. Welch explained that the main object of the new institute was to combine scientific research with practical work in commerce and industry; it was not established for profit, and all the fees received would be used to further these aims. Dr. C. S. Myers, F.R.S., Director of the Psychological Laboratory, Cambridge, who has been one of the moving spirits in the foundation of the institute, emphasized the necessity for careful research. An executive committee of the institute was thereafter formed, and also a scientific committee, including representative psychologists and physiologists. The office of the institute is at 329, High Holborn, W.C.

YELLOW FEVER IN NORTHERN PERU.

THE series of investigations into the etiology of yellow fever undertaken by Noguchi in South America, which has resulted in the description of *Leptospira icteroides* as the causal agent, has now been extended to Northern Peru by Noguchi and Kligler.¹ The *Leptospira icteroides* was first isolated by Noguchi from cases of yellow fever at Guayaquil in Ecuador, and subsequently from a case at Merida in Mexico; these strains were shown to be morphologically and serologically identical. Peru, which has suffered many visitations by yellow fever, was again invaded in June, 1919, and this outbreak had not disappeared entirely when Noguchi and Kligler arrived in March, 1920. The mortality was estimated at about 10 per cent., which is much lower than the 50 per cent. mortality in Guayaquil and Merida. Fourteen typical cases of yellow fever were studied in Northern Peru, nine in March, 1920, at Payta, where the laboratory facilities were very imperfect, and five in April and May at Morropou and Piura. A typical leptospira infection, together with the demonstration of the organism in experimentally infected guinea-pigs, was obtained in four, and in the majority of instances indications, such as fever, haemorrhagic areas in the lungs, and occasionally a suggestion of jaundice in the inoculated guinea-pigs, were observed; in a few cases only were the results entirely negative. The leptospira isolated from the Morropou cases of yellow fever was morphologically and culturally identical with the Guayaquil and Merida strains of *Leptospira icteroides*, and was shown by immunity tests to be indistinguishable from the Guayaquil strain. Study of the immunology of the Peruvian strains proved that the serum of patients convalescent from yellow fever at Payta, Morropou, and Piura gave a positive Pfeiffer reaction with leptospira strains isolated in Guayaquil and Merida, and in the majority of instances protected guinea-pigs from these strains. The virulence of the Morropou strains was approximately the same as that of those from Guayaquil and Merida. Suitable quantities of the anti-icteroid immune serum prepared with the Guayaquil strains administered to guinea-pigs inoculated with 2,000 to 20,000 minimal lethal doses of infective material prevented infection or death, according as the serum was given during the incubation period or after fever had appeared. Guinea-pigs from Payta were much more resistant to infection with leptospira than were guinea-pigs recently imported from New York. It was found that rabbit serum that had undergone long journeys in a tropical climate deteriorated as a culture medium for

Leptospira icteroides, and that failure to obtain a growth in such serum occurred, whereas a growth was obtained with fresh rabbit serum; but the Peruvian strains had a tendency to degenerate early in culture.

ARTIFICIAL LIMBS.

DR. GABRIEL BIDOU, who is known as an orthopaedic surgeon and an advocate of a system of artificial muscles for the instrumental treatment of paralysed and weakened limbs, has contributed a short paper to the Medical Society of the Paris Hospitals on the improvement of artificial limbs.¹ He complains that the limbs at present supplied are defective owing to their weight, the practical absence of support and of a proper seat for the tuberosity of the ischium. The result of the last two defects is that the stump is forced into the socket in an attempt to get support. Dr. Bidou does not say what the weight of any French limb is or should be, nor does he mention any average weight for any type of limb. It is therefore impossible to make comparisons between the limbs he criticizes and those of the Ministry of Pensions in this country. From such evidence as is available we are inclined to the opinion that our own official limbs are superior to the French, and probably to those of all the other belligerent nations. Although Dr. Bidou adversely criticizes willow-wood and raw hide sockets, he does not recommend any substitute, but he advocates the use of artificial muscles for the control of prostheses in a manner similar to that which he has recommended in his pamphlet on instrumental orthopaedics.

THE Senate of the University of London, on March 16th, adopted a resolution to continue the physiological laboratory at South Kensington until the end of the current triennium—that is, until the end of 1923.

A DINNER of congratulation to Professor Sherrington on his election to the presidency of the Royal Society was given by the Physiological Society on March 11th at the Café Royal, London. Professor Sir E. Sharpey-Schafer, who presided, proposed the toast of the guest, and his speech and Professor Sherrington's reply were the only speeches.

¹ *Bulletins et Mémoires de la Société Médicale des Hôpitaux de Paris* (Séance du 3 Décembre, 1920).

PRESENTATION TO DR. J. A. MACDONALD.

THE following further subscriptions have been received from February 6th to 28th, 1921, in response to the appeal published in the JOURNAL of July 24th, 1920 (p. 129), towards a presentation to Dr. J. A. Macdonald on the occasion of his retirement from the office of Chairman of Council of the British Medical Association which he had held for ten years. Subscriptions of any amount not exceeding five guineas should be made payable to "The Macdonald Presentation," and sent to the Medical Secretary, British Medical Association, 429, Strand, London, W.C.2.

FOURTEENTH LIST OF SUBSCRIBERS.

	£ s. d.		£ s. d.
Brought forward from last list of subscribers	894 166	Davis, Mr. E. D. D., London	2 2 0
Strover, Dr. H. C., Sandy Beds.	1 1 0	Per Dr. A. C. S. Waters (Hon. Sec. Isle of Ely Division)	
Macdonald, Dr. Geo., Ruabon	0 10 0	Lucas, Dr. G. H., Wisbech	0 5 0
Hirst, Dr. W. J., Birmingham	1 1 0	Harding, Dr. C. H., Whittlesea	0 5 0
Asten, Dr. Walter, Bournemouth	0 10 0	Clapham, Dr. H., Thorney	0 5 0
Certain members of South Essex Division, per Dr. J. F. Walker (Honorary Secretary)	4 5 0	Fain, Dr. A., Thorney	0 5 0
Alexander, Dr. David A., Bristol	2 2 0	Stephens, Dr. C. E. S., Doddington	0 5 0
Benson, Surg.-Gen. P. H., I.M.S.(ret.), St. Aubins, Jersey	1 1 0	Hendley, Dr. P. A., Littleport	0 5 0
		Wilson, Dr. J. W. A., Wisbech	0 5 0
			£99 3 6

¹ *Journ. Exper. Med.*, 1921, xxxiii, 239-260.

Medical Notes in Parliament.

Criminal Law Amendment: The Bishop of London's Bill.

IN the House of Lords, on March 9th, the Bishop of London moved the second reading of a Criminal Law Amendment Bill based on that which he introduced last year. The earlier measure, a bill brought forward by Earl Sandhurst for the Government, and another by Earl Beauchamp, were referred to a Joint Committee of Lords and Commons under the chairmanship of Lord Muir Mackenzie. The report of this Committee, which contained recommendations to the Government, was published during the recess. The Bishop of London's new bill contains six clauses. Clause 1 lays down that it shall be no defence to a charge of indecent assault on a child or young person under the age of 16 that he or she consented. Clause 2 proposes to raise the age, in the sections of the criminal law relating to carnal knowledge of a girl from 16 to 17, and to repeal the subsection which makes "reasonable cause to believe that a girl was 17 years of age" a defence. It further proposes that the period within which complaint may be made shall be extended from six months to twelve. Clause 4 would heavily increase the fines and terms of imprisonment for brothel keepers. To relieve the bill of controversial matters the bishop left out of it any proposals to deal with the communication of venereal disease, the compulsory detention of young girls in homes, the prevention of prostitution in flats, and the former clause for the protection of boys. He explained that the reason why he now asked for the age of consent to be raised only from 16 to 17, and not to 18, was that Lord Muir Mackenzie's committee did not favour raising the age. Moreover, he thought that raising the age one year, with repeal of the subsection allowing reasonable belief as a defence, would mark a great advance. The bishop quoted from a report as to the conditions of London not yet published by the County Council. This showed that in the clinics of London (and only about one-tenth of the cases went to these clinics) there were 27,364 new cases in 1919, and 298,066 attendances. In the London Hospital clinic the numbers had increased from 658 new patients in 1918 to 1,452 new cases in 1920. These medical authorities reported in their careful summary that a large percentage of the patients was quite young—from 16 to 20 years of age. They said that seduction and desertion operated powerfully as a cause of prostitution. Referring to the proposals put forward by the Society for the Prevention of Venereal Disease for the distribution of packets and allowing chemists to sell preventives, etc., the bishop said he agreed with the late Lord Downham when he said that if this sort of thing really came to England it would be the beginning of the end. Coming to the work of the National Council for Combating Venereal Diseases, the bishop thought that its progress must necessarily be very partial and slow. In answer to the argument for licensed houses, he commended for attention Flexner's work on *Prostitution in Europe*. It had been proved that in every capital in Europe venereal disease had increased in almost exact proportion to the extent that the system was introduced.

Lord Onslow (for the Government) stated that, in view of the differences of opinion in the Joint Committee on the Government's bill of last year, it would not be reintroduced. The bill now presented by the Bishop of London omitted the most highly controversial matters, and the Government regarded it sympathetically, and would, if it progressed without material change, consider whether time could be found for it in another place. As for the age of consent, the Government bill proposed to leave it at 16; but the Home Secretary considered that the balance of opinion, in view of the further arguments, was for raising the age to 17.

Lord Phillimore, after reminding the House that he had sixteen years' experience as a judge of assize, gave his reasons for holding that if the subsection as to reasonable cause to believe were taken away the age should not be raised to 17, but ought to be reduced to 15. If the subsection were retained, the age might, he thought, be raised to 17. The Earl of Malmesbury, speaking as a member of the Joint Committee, held that the age should, with the removal of the subsection, be kept at 16. Lord Coleridge, recalling, like Lord Phillimore, assize experience, thought that if the raising of the age to 17 were accompanied by removal of the reasonable belief ground of defence, Parliament would be going beyond public opinion. Viscount Cave said he would rather have the clean cut—retain the age of 16, and abolish the particular defence, than raise the age and leave the defence standing. He said this with twenty years' experience as chairman of quarter sessions, and from what he had learned from London magistrates when he was at the Home Office. Lord Gorrell supported the bill as it stood, emphasizing the amount of support it had behind it from organizations.

Lord Dawson of Penn concurred with other peers as to the gravity of the evils, but feared that in some respects the bill would not succeed in removing the evils they greatly desired to remove. He did not say that the bill was not a good one; but there were certain respects in which it was liable to do harm. As to Clause 1—consent no defence in indecent assault cases—it was, he thought, necessary to distinguish between the sexual instinct which was based on nature and the sexual instinct which was unnatural and perverted. He took it that this clause was mainly directed against the older offenders—men and women. Misdoings of that description could not be dropped on too heavily; but the clause seemed to him to include the possibility of bringing into its meshes the young, and possibly

the boy of 18 accused of an offence against a girl of 15 or 16. It seemed to him that such offences were on an entirely different footing. That was the natural instinct which overbowed at an age when restraint was deficient. Such young people did not require the dock. They rather required education, uplifting and moralisation. He suggested that some proviso should put them on a different footing from the older offenders. On the question of the age of consent for carnal knowledge from 16 to 17, Lord Dawson assumed that when the Legislature raised it to 16, the view was taken that the young person of 16 was too immature to be what he might call "a conscious sexual instigating agent." But after 16, the changes taking place in a girl were often very rapid, very capricious, and very marked. It was quite easy to select five or six girls at the age of 17 who could represent by appearance any age from 15 to 21. It was the fact, therefore, that after 16 the girl was apt to develop very quickly and with that development became a conscious sexual agent. That was where his difficulty lay in raising the age. He was anxious to give all the protection that could be granted; but the moment the girl became a conscious and often an intentional instigating agent it seemed to him extremely difficult to throw the whole blame for sexual misdoing upon the man. The girl became jointly to blame with the man with whom she offended. It was a curious fact that the large body of public opinion which was constantly maintaining that there should be an equal standard of responsibility for the two sexes, a view with which he had considerable sympathy, should now be willing to protect the girl at the expense of the man. Example after example could be quoted where the girl could be the prime offender, and vice versa. It did not seem right to him to throw the whole onus on the man. He wished it to be clearly understood, however, that he was not concerned with the older man. The older man of 25 had developed a certain amount of stability and was quite capable of forming just opinions. There was another point of view which made one hesitate about placing responsibility for sexual intercourse exclusively on the male. Certain physical realities of life seemed to have been almost entirely ignored by many earnest social reformers. Coming down to consider the elemental things of life, it would be agreed, as to the instincts that moved men and women in sex matters, that the first outstanding instinct of the male was pursuit. It might be checked in civilized society by moral and religious ideas; but it was elemental. The instinct of the female was resistance and reserve, followed, it was true, by surrender; but, broadly speaking, she had the reserve, the resistance. That physical instinct was the basis of woman's modesty. Of all the forces that existed anywhere for sexual morality the most potent individual force was woman's modesty. The second point he wished to bring out, viewing the matter from the point of view of physical realities, was that the desire of the woman was much more conditional than it was with the man. The average woman had to love before she had passion, or, at any rate, she had slowly to develop a strong liking for an individual before that passion was aroused. She had none of the promiscuous qualities of the male, and unconsciously or consciously her sexual instinct was associated with the conception of maternity. She was therefore much more protected by Nature than the male. The ordinary girl of between 16 and 17, if reasonably brought up, had a much greater natural defence than the male. That raised a doubt in his mind as to throwing the whole responsibility on the male. Either the age must be left as it was or both male and female must be made responsible before the law for illicit sexual intercourse. With regard to brothels, he entirely agreed that the heaviest possible penalties should be put on the proprietors of places where proprietors farmed the earnings of women who resorted to them or where such women lived or resorted. But he had an apprehension whether, if legislation were too repressive, so that small hotels conducted in an orderly manner were brought within the law, the base of promiscuous intercourse might not thereby be further widened—driven into the back rooms of restaurants, into tea-rooms, into dancing places, and even into the homes. For that reason caution was required. He should not like it to be thought he was taking up an attitude of no action. Many provisions in the bill could be supported with confidence. But he did not believe that the problem of promiscuous intercourse was going to be met by legislation. It was going to be met by social reform and betterment; by encouraging community life such as was exemplified in the idea of garden cities, larger recreation grounds for the people, and the better education of youth. These were the remedies, it seemed to him; facilities for earlier marriage, the return to the larger family, and the frank recognition that if people were going to marry they must have control over the output of their offspring.

Lord Muir Mackenzie said that the bill, as far as it went—coincided with the recommendations of the Joint Committee, except in raising the age of consent to 17. The Committee agreed on the age of 16 and to get rid of the defence of "reasonable cause."

The bill was read a second time.

The measure was taken in Committee in the House of Lords on March 15th. The Bishop of London announced that, having regard to the discussion on the second reading of the measure, he was willing to accept an amendment, standing in the name of Lord Muir Mackenzie, which would retain the age of 16, but provide that reasonable cause to believe that a girl was over 16 years of age should not constitute a defence. He believed that by getting rid of that ground of defence there would be a great gain of protection for young girls; and, if the

measure passed through their Chamber as an agreed bill, there would be a greater possibility of its being accepted in another place. Lord Mair Mackenzie afterwards moved to substitute for Clause 2:

"Reasonable cause to believe that a girl was of or above the age of 16 years shall not be a defence to a charge under sections 5 and 6 of the Criminal Law Amendment Act."

This was accepted. The Lord Chancellor moved a new clause repealing the present law under which proceedings under the Incest Act are held in camera. This also was agreed to.

The Increase of Cancer.—In reply to Mr. Gilbert, on March 9th, Dr. Addison said that an extensive research into the causes of cancer had for some time past been undertaken by the Imperial Cancer Research Fund, and the Medical Research Council was facilitating research into the possibilities of radiotherapy and had been the means of providing a substantial quantity of active radium salts for the purpose. Cancer research funds were relatively well supported from voluntary sources, and he did not think that the issues were sufficiently clear for him to recommend grants in aid of the cost of the treatment of this disease at the present time.

Malaria Cases in Great Britain.—Captain Elliot asked, on March 9th, whether, in consequence of the number of men in this country who still suffer from malaria contracted abroad during the war and of the abundance of mosquitos present in many parts of England, malaria was now occurring in the civil population. Dr. Addison replied that the action taken was fully described in two separately issued reports on malaria contracted in England relating to 1917 and 1918 respectively, and in the annual report of the chief medical officer for 1910-20. The policy of prevention was based primarily on securing the early detection of all cases and carriers of malaria and arranging that the cases were thoroughly treated with quinine, thus removing, or greatly lessening the risk of infection if they were bitten by mosquitos which could spread the infection. Efforts were made at the same time to protect all such cases and carriers against mosquito bites as far as possible. Special supervision for these purposes had been arranged in the Isle of Sheppey, where most of the infection arising in England had occurred. The measures taken had greatly lessened the risk of spread. The total number of locally contracted cases reported among the civil population in England was only 32 in 1920, as compared with 93 in the previous year.

Lunacy Act Terms.—Dr. Addison stated, on March 10th, that he was in sympathy with the spirit of the resolution passed by the Committee of Visitors to the Isle of Ely and Borough of Cambridge Mental Hospital, that the terms "pauper lunatic" and "pauper inlatic asylum" should be discontinued, and that the terms "patient" and "mental hospital" should be substituted. The change, however, would require considerable amendment of the Lunacy Act, and he feared that words substituted would tend to acquire the same associations.

The Dental Bill.—Dr. Addison stated, on March 10th, that he hoped to confer shortly with the various representative organizations concerned with a view to the introduction of the Dental Bill as an agreed measure, but he was not at present in a position to name any date for the introduction.

Tuberculosis Treatment.—Dr. Addison assured Sir Arthur Holbrook, on March 9th, that the question of adequate and permanent representation for the members of the Insurance Committees upon the new Committees to be appointed on the transfer of tuberculosis treatment to County and Borough Councils was being borne in mind by him in regard to coming legislation.

Ministry of Pensions Expenditure: The Medical Services.—In answer to Lieut. Commander Kenworthy, on March 7th, Mr. Macpherson replied that the expected total annual cost of administration of the Ministry of Pensions for the current year approximated to £6,500,000; of that amount £3,000,000 related to general administration, £2,300,000 to medical services, and £1,240,000 to local war pensions committees. The number of persons (excluding widows, children, and dependants) in receipt of pensions on August 1st, 1920, was 1,117,000, and on February 1st, 1921, it was 1,060,000, and the respective annual costs thereof £61,598,000 and £60,484,000. The annual expenditure incurred in respect of medical boards was £1,712,000, the cost in salaries and fees to medical officers being £994,000. There were 564 whole-time medical officers employed on August 1st, 1920 (215 being engaged in institutions), and 592 employed on February 1st, 1921, of whom 257 were engaged in institutions. The number of disabled men who were in receipt of pensions on August 1st, 1920, and had now ceased to draw pensions by reason of death, being settled by gratuity or a final weekly allowance in lieu of pensions, and of their disability having become less than 20 per cent., was 103,000. The number of 20 per cent. and 30 per cent. pensions in payment at February 1st, 1921, was 390,000 and 245,000 respectively. Lieut. Commander Kenworthy also inquired what parliamentary authority there was for the constitution of medical boards composed of three medical men. Mr. Macpherson, in reply, referred to the agitation which led to the formation of such boards.

Pensions Appeal Statistics.—Mr. Macpherson, at the instance of Mr. Cape, stated, on March 8th, that the number of appeals heard by the pensions appeal tribunals between February 28th, 1920, and February 28th, 1921, was 14,487; of this number 4,384 were allowed and 10,103 were rejected.

Health of Soldiers at Cologne.—Lieut. Colonel Buckley asked the Secretary for War, on March 8th, whether his attention had been called to the grave allegations concerning the Army of the Rhine made by the Rev. W. Talbot Hindley, a chaplain of the Territorial Force; and, in particular, whether there was anything to justify the statements that the conditions of life in Cologne made a death-trap for our soldiers, that 95 per cent. of one unit had been through hospital, and that there was a cemetery largely filled with suicides and victims of venereal disease. Sir J. Worthington-Evans said that the Army Council was in communication with the reverend gentleman concerning these. There was no justification whatever for the statements attributed to him. During the period from January 1st, 1920, to January 31st, 1921, the monthly average of admissions for venereal disease was 1.4 per cent. of the total strength; there were 85 deaths from all causes, but none from venereal disease; 5 were due to wounds self-inflicted.

Dangerous Drugs in India.—Mr. Montagu informed Mr. Gilbert, on March 9th, that in India the regulation of the traffic in and use of dangerous drugs is controlled by a variety of local and Imperial Acts. It is believed that the law and practice in India in respect of such drugs are entirely in accord with the provisions of the Hague Convention. Some time ago, however, the Government of India was requested to look into the matter and to effect such amendments, if any, as might be required.

Insurance Committees and Medical Record Cards.—Replying to Mr. Bartley Dennis, on March 9th, Dr. Addison said that he had received representations as to the new medical record cards from only four Insurance Committees. In three cases the representations were on matters of detail, and in the fourth the Committee had resolved that the keeping of the records was desirable for securing a proper medical service. The Chairman of the National Association of Insurance Committees had written that the Executive Committee of that body held that the keeping of the records was unquestionably in the interests of the insured persons.

Termination of Sanatorium Benefit.—Dr. Addison, in answer to Mr. Wignall, on March 8th, said that the date fixed for the termination of sanatorium benefit in England and Wales was April 30th next, and he was hoping to introduce shortly a bill dealing with the arrangements to be made for the treatment of tuberculosis after that date.

Wellhouse Hospital, Barnet.—In answer to Lieut. Colonel Fremantle, on March 9th, Dr. Addison stated that a loan of £40,000 was sanctioned for the erection of Wellhouse Infirmary, Barnet, and £38,505 were raised by the guardians. The infirmary was opened only recently, and no figures of the running costs, or of the amounts recovered from persons relieved in the infirmary, had yet been returned. The clerk to the guardians reported that the staff numbered 36, and there were also two consultants.

Whole-time Medical Officer for Bromley.—Asked by Lieut. Colonel James, on March 2nd, as to the proposed appointment of a whole-time instead of a part-time medical officer for Bromley, Dr. Addison said that the whole-time public health staff employed by the Bromley Borough Council consisted of two health visitors acting under the general supervision of the Medical Officer of Health. There were in addition certain officers employed on the school medical service. The appointment of a medical officer of health rested with the Borough Council, and the proposal to employ a whole-time medical officer of health came from them. In addition to performing the duties of medical officer of health, whoever was appointed would act as supervising school medical officer and be in charge of the maternity and child welfare of the borough. He was advised that the proposed arrangement would be economically useful, and did not see his way to withhold general approval of it.

Clinical Thermometers.—Mr. Kiley asked, on March 7th, whether a manufacturer of clinical thermometers was liable to be sent to prison in selling his products accompanied by a certificate that they had been tested unless the goods were sent to a Government department to be again tested. Sir P. Lloyd-Greame said that a seller had to comply with the Order in Council made during the war under the Defence of the Realm Act.

Glamorganshire County Asylums.—Dr. Addison, in reply to Mr. Stanton, on March 3rd, said he was advised by the Board of Control that an expression used by Mr. A. B. Marriott at the Merthyr Tydvil Board of Guardians on the previous Saturday, namely, that the patients at the Glamorganshire asylums were herded together, was not justified by the facts. The reports on the institutions which had been received did, however, indicate certain defects, and he was having the matter further investigated.

Answers in Brief.

The agreement for the supply by the Government of India of opium to the Government of Hong Kong has been renewed for a further period of five years, with certain modifications. Under the new agreement, which has effect from January 1st, Hong Kong will be supplied with ten chests of opium per month at a fixed price. No obligation rests on the Government of Hong Kong to take any prescribed minimum quantity.

Grants amounting approximately to £855,000 will be made during the current financial year towards the expenditure of local authorities on maternity and child welfare. The grants represent less than 1d. in the £ on the total sums voted by Parliament for the supply services of the country.

South Australia.

FROM OUR SPECIAL CORRESPONDENT.

MEDICAL LEGISLATION.

THE session of Parliament which has just closed has seen the enactment of several laws affecting, more or less, the medical profession. First and foremost the Venereal Diseases Act brings the State into line with the sister States of the Commonwealth. It provides for the treatment of patients either by a private practitioner or in a public institution until they have received a certificate of "cure" or of "freedom from venereal disease"; it prohibits any but medical practitioners treating such cases; it requires the practitioner to notify the Inspector-General of Hospitals of the case, without divulging the name or address unless the patient ceases to attend the doctor or institution, in which case his name and address is to be furnished. It provides for the education, by means of suitable literature, of the person infected, for the warning of the other party if marriage be contemplated, and it penalizes the individual who knowingly communicates any such diseases either in matrimonial or illicit intercourse. Another sweeping prohibition is that which forbids an infected person to work in any shop, factory, hotel or steamer, etc., in any capacity which involves the handling of food. There is a clause also which prohibits the obnoxious advertisements common even in respectable lay newspapers. Treatment is to be compulsory, and therefore, as a natural corollary, free treatment is to be provided; female sufferers may demand examination by a medical woman, if there be such a one, willing to act, and resident within twenty miles. The Act positively bristles with penalties, chiefly directed against medical practitioners, and ranging from a modest fine of £5 up to five years' imprisonment, with or without a mulct of £500. In considering the bill legislators seem to have been governed by the optimistic opinion of certain specialists, who asserted that these diseases might be exterminated; so they might, but we heard the same thing about tuberculosis five-and-twenty years ago. So far as the Act insists upon adequate treatment it is good, but the general opinion is that it will be found unworkable, and that it will be impossible to maintain the idea of secrecy; great and unnecessary hardships will, it is thought, be inflicted. What employer would take back the grocer's assistant or the restaurant waitress who has suddenly to vacate a position? It is asked whether the tests as to the existence of these diseases, and still more as to their cure, are absolutely trustworthy; whether, indeed, the correct principles of treatment of either syphilis or gonorrhoea are yet standardized. The almost universal prevalence of syphilis in some form was roundly asserted, and legislators were frightened by the statistics, and, withal, so innocent that one of them even thought that a doctor could determine freedom from venereal disease "in young girls" by a cursory examination consisting of lifting up an eyelid. Labour members especially were afraid that doctors would be bribed to give false certificates unless the fines were heavy.

THE OPTICIANS ACT.

The opticians have now obtained their wish. There is to be a "Board of Optical Registration"; it will consist of three competent opticians and two registered medical practitioners, and a majority of its members will be nominees of the Government. As, however, there is a suspicion that the Board may be boycotted by the doctors, provision is made for the whole Board to be composed of opticians. Paid examiners are to be appointed to examine budding opticians who aspire to practise optometry and to be registered as opticians. They are not to call themselves oculists, nor to use mydriatics, nor to prescribe for eye diseases. Another duty of the Board is to license spectacle sellers, but such vendors shall not aspire to practise optometry. Woo to the hawk who "peddles, barters," etc., spectacles. Master Moses Primrose will run no risk in future of being taken in by the itinerant vendor. The eye specialists opposed this Act on the grounds that the opticians who prescribe spectacles often overlook diseases of the fundus. Doubtless this is sometimes true, but the evil is probably exaggerated, and with the limitations prescribed by the Act it is difficult to see what

greater harm will be done by registering them; doubtless also a tendency will grow to create a close guild of opticians.

NURSES' REGISTRATION ACT.

The examination and registration of South Australian nurses has hitherto been conducted chiefly by the Australian Trained Nurses' Association, which has its headquarters in Sydney, but probably in future this function will be taken over by the newly-appointed Nurses' Board of South Australia. There are to be three classes: ordinary nurses, mental nurses, and midwives. With respect to the latter the Board has power, in order to prevent the spread of diseases, to inhibit a nurse, registered or unregistered, from practising as a midwife, and after the expiration of a year no woman will be allowed to act as a midwife who is unregistered, emergencies excepted, such as a confinement occurring more than five miles from the nearest doctor or midwife. The other provisions of the Act do not call for comment.

Scotland.

WINTER CLINICAL MEETING OF THE EDINBURGH BRANCH.

THE winter clinical meeting of the Edinburgh and some other Scottish Branches of the British Medical Association was held in the Royal Infirmary, Edinburgh, on March 4th, and was in every respect most successful. The museum of pathological and other specimens, which was open all day in the pathological department, was visited by a large number of members. From 10 a.m. until 3.15 p.m. a number of demonstrations were given in the wards and special departments on, for instance, "Modern methods of treatment of syphilis and gonorrhoea" by Mr. D. Lees; "The colloid gold test for cerebrospinal fluid in general paralysis of the insane and other disorders," by Miss Wilson; "The therapeutic uses of radium," by Dr. Dawson Turner; "Cases illustrating a new method of treatment by tuberculin," by Sir Robert Philip, and others by Dr. J. V. Paterson and Dr. A. H. H. Sinclair, Dr. Hope Fowler and Dr. A. McKendrick, Dr. Chambers Watson and Dr. Lipschitz, and Dr. Norman Walker. At the clinical demonstration in the evening the large surgical theatre of the infirmary was almost filled. Dr. J. J. Graham Brown, president of the Branch, was in the chair, and a large number of interesting cases were shown by members of the medical and surgical staffs of the Infirmary. At 5 p.m. an address was given by Dr. J. S. Haldane, F.R.S., of Oxford, on "Some recent advances in the physiology of respiration, circulation, and renal excretion," which was listened to with very evident appreciation; the address is published in this issue of the Journal (p. 409). In the evening a dinner was held in the Caledonian Station Hotel, which proved to be a most enjoyable function, although the number present was rather less than last year. Among the guests, besides the Chairman of the Scottish Committee and the Scottish Secretary of the Association, were Sir Robert Philip, President of the Royal College of Physicians of Edinburgh, Dr. George Mackay, President of the Royal College of Surgeons of Edinburgh, one of the Presidents of the Royal Medical Society, and one representative resident from the Royal Infirmary. The honorary secretary of the Edinburgh Branch, Dr. John Stevens, must be congratulated on the continued success of the annual winter clinical meeting.

Ireland.

THE DUBLIN ASSOCIATED HOSPITALS.

THE accounts of the fête held at Ballsbridge last October were presented to a council meeting of the Dublin Associated Hospitals Fund at the Royal College of Physicians on March 10th. The gross receipts amounted to £19,684 after paying expenses, the net balance was £15,655. The Lord Chancellor (Sir James Campbell, who presided, said that the result might be regarded as satisfactory, although some hospitals might have done better. Sir Patrick Dunn's Hospital headed the list with £2,305, the Meath Hospital came next with £1,986, Stevens's Hospital third with

£1,632, and the Royal City of Dublin Hospital fourth with £1,527. Changes had been made in the administration of the hospitals in Dublin which he hoped would relieve the public to a large extent of the perpetual appeals for assistance. Arrangements had been made for a better system for paying patients and for obtaining contributions from the poorest; in the future the county councils would bear a fair share of the expenses incurred by the hospitals in treating the inhabitants of their districts. Most of the county councils had admitted the claims of the hospitals in a generous spirit. Sir Henry McLaughlin, the honorary organizer of the fête, said that the general position of the Fund was unsatisfactory. The total amount of the collection over and above the balance from the fête was £19,200; of this about £10,000 had been raised in country districts; about £9,000 had been subscribed by Dublin citizens. Plans which they had for a winter campaign had to be given up owing to the curfew orders. Professor James Craig, President of the Royal College of Physicians, proposed the following resolution, which was carried: "That the effort being made to remove the debts from the Dublin hospitals is worthy of the consideration of the business and commercial interests of the city." He said that, if the hospitals were not supported, either the hospitals must close or they must come under State or municipal control, either jointly or separately. If the latter alternative came, it followed that the hospitals would probably be under different management. There would be democratic control, and democratic control, he believed, would in this case be a mistake. He hoped the business and commercial men would see to it that the Dublin hospitals did not come under either State or municipal control.

Correspondence.

X-RAY RADIATION AND CANCER.

SIR.—The letters of Dr. Hernaman-Johnson and Dr. Mitchell require an answer, as they preach a pernicious doctrine. They seek to substitute a new and untried method, claiming to be based on certain animal experiments, for a treatment that has been worked at for years, the limitations of which are known, a treatment which has given steadily improving results as the doses and the penetration of the rays have been increased. The Erlangen method is a development on lines along which I have been striving to advance for many years, but have been prevented by inadequate apparatus. Whether one treatment will ever be sufficient to destroy a carcinoma is doubtful. The Erlangen school use two in carcinoma of the cervix, only they say that one is for the cervix and the other for the parametrium. I have not yet had an opportunity of investigating this treatment on the spot, but the theory is sound, though it is almost certain that the results will not be as good as is claimed. The method is bound to be a dangerous one, as great accuracy is necessary in the directing of the beams of x rays.

I for one will assert that x -ray treatment of carcinoma of bone—though one rarely gets a chance of treating this condition—has immeasurably improved in the last few years, together with the radiation treatment of all other deep-seated malignant growths.

Why should the experiments be ignored which show that radiation of a malignant growth will, if sufficient, prevent its implantation into another animal, and, if enough, but not too much, radiation has been given, will immunize the animal in which it is implanted? The experiments mentioned in the paper by Professor Russ and his colleagues were irradiation of the whole animal at a considerable distance from the tube, so far that to get a similar result on the much bigger human being the x -ray source would have to be at the other end of a long room. It is even possible that our radiations of a local growth, with its consequent irradiation of a comparatively small section of the body, may have a similar effect to these doses on the whole body of the small and easily penetrated rat. The experimenters with small doses have never claimed more than that in a larger proportion of the irradiated animals than in the controls the growth did not "take." In a quite considerable percentage the growth did "take."

I see many cases where insufficient irradiation has failed or has even apparently stimulated a growth and yet

which, when large doses are employed, show marked and rapid improvement.

The treatment has its limitations; not all types of growth are suitable. At the same time it is not all growths which are stimulated by insufficient irradiation, but I have seen a few cases in which this has apparently occurred—only a few, as I take care to give large enough doses.

As to combining radiation treatment with surgery, the proper method is first of all to give a thorough irradiation to prevent implantation of cancer cells, taking care not to injure the skin; next to excise the growth as thoroughly as if no radiation had been used, and then to do prophylactic treatment.

I am convinced that the future in radiation treatment of malignant disease lies in more penetration and bigger doses.—I am, etc.,

London, W., March 14th.

N. S. FINZI.

SIR.—Dr. William Mitchell asks whether the statement so often made "that weak doses (of x rays) stimulate malignant growth" is one of the "myths" that are constantly copied from one writer by another or whether there is any evidence, experimental or otherwise, to prove it.

I think I may be in part responsible for the statement, for in my Hunterian Lecture¹ on x -ray cancer and the conditions that precede its onset, delivered in 1909, I brought forward the results of experiments on rats and rabbits that appeared to afford unmistakable evidence of the stimulating effect of small doses of x rays upon normal epithelial structures.

It obviously would be a matter of extreme difficulty to furnish experimental evidence of any value in regard to a similar effect upon malignant epithelium owing to the impossibility of setting up a fair standard of control. But it is noteworthy that the epitheliomas of the skin of x -ray operators, which constitute the only known examples of the experimental production of cancer in man, would appear in the majority of cases to have been occasioned by oft-repeated casual doses, resulting from lack of protection and not by a massive and at once injurious dose.

It is also, I think, worth remembering that the effective dosage delivered by any stream of x rays must at some point in its passage through the tissues become a small one, dependent, of course, upon the various technical details concerned in its production, and upon the degree of absorption by the tissues through which the stream is passing.—I am, etc.,

London, W., March 14th.

CECIL ROWNTREE.

SIR.—In the discussion of this important matter, it is necessary to avoid misconception. Dr. William Mitchell, in your issue of March 12th, makes the following statement: "I have seen it too often to have any doubt on the subject that operation for mammary carcinoma, of even the most favourable type, and done in the most thorough manner by the most capable surgeons, is followed in a large percentage of cases [the italics are mine] by rapid dissemination, which I am sure could have been averted by pre-operative treatment" (that is, x -ray radiation). Dr. Mitchell's experience must have been singularly unfortunate, and I venture to think unique. Every surgeon has probably met with early cases of cancer which appeared very favourable for radical operation; yet the operation proved a disappointment, and rapid dissemination supervened. But, apart from Dr. Mitchell's unfortunate experience, to imagine that this occurs in a large percentage of cases would surely be a gross misconception of fact. It is surely and fortunately quite a rare event. Whether in these cases a pre-operative course of x -ray radiation would have prevented its occurrence is difficult if not impossible to prove.

My objection to the pre-operative x -ray radiation of cancer is that it keeps the patient dallying with his disease, encouraging him in his natural desire to avoid operation by a seeming or real improvement in his condition, losing time which may mean him losing his life. When the certainty of cancer exists the sooner it is removed the better, and I should require much more convincing proof than the *ipse dixit* of the radiologist that he was sure that rapid dissemination could be prevented by a

¹ *Lancet*, March 20th, 1909.

course of pre-operative x-ray radiation before advising a patient to postpone operation for operable cancer a single day. On the other hand, I have for many years past advised my patients to undergo a course of post-operative x-ray radiation. There are these clinical facts about cancer: In some cases where the local origin is quite insignificant there is a great tendency to rapid and wide dissemination, and that quite apart from any operative procedure whatever. In other cases where the local origin is extensive the disease seems to expend itself locally, and the tendency to dissemination is much less. That is, so far as I know, one of the mysteries of this mysterious disease. That is why it is always worth while to remove cancer, however extensive, provided there is a reasonable chance of getting the palpable disease away. The most apparently hopeless case of carcinoma of the breast, from the point of view of prognosis, that I have ever operated upon—a young woman with a large and rapidly growing medullary carcinoma filling the breast, and secondary glands as large as walnuts in both the axillary and supraclavicular regions, advised, and apparently justifiably advised, against operation by a very eminent London surgeon—sent to me by Dr. H. W. Jeans of Portsmouth, is alive and well now, ten years after operation. In this case, wishing to give her every loophole possible in an apparently forlorn hope, I removed both her ovaries as well. Whether this had anything to do with the result of the operation I do not know. But the next case in which I tried it had a very rapid recurrence. The vagaries and uncertainties of this mysterious disease are untold, and conclusions and generalizations are apt to be consequently fallacious.—I am, etc.

CHARLES P. CHILDE, B.A., F.R.C.S.

Portsmouth, March 14th.

CHRONIC RETENTION OF URINE ARISING FROM PROSTATIC DISORDER.

Sir,—I doubt whether Mr. Herbert T. Herring has told quite the whole story in his interesting paper (March 12th, p. 376). How does he account for the increased frequency of micturition which is a marked symptom of enlarged prostate long before there is anything like 10 oz. of residual urine? I believe the symptom is common before there is any residual urine at all. A majority of men over 60 pass water two or three times each night, which means that they can only hold some 5 or 6 oz. with comfort. It is not overflow from a distended bladder, for a catheter shows little if any residual urine. He says "prostatic resistance is generally augmented by enlargement." Why, then, does the subject of commencing enlargement pass water more frequently? He ought to have to wait until the "tonal bladder pressure" is sufficient to overcome the increased prostatic resistance.

One practical question for the practitioner is, When ought he to insist on passing a catheter? Should he insist if the urine is normal but passed only 3 or 4 oz. at a time, or should he wait until there are some signs of retention? The passage of a catheter is not devoid of danger.

Mr. Herring's treatment seems to me a bit risky. It might be done in hospital, but it would be dangerous in private practice, and a terrible ordeal for both patient and medical attendant. If the catheter is left to the patient "a breakdown in the technique adopted with regard to the preparation and passing of the catheter" is almost certain. The timing of the catheter would be difficult, for the secretion of urine is extremely irregular. Some nights a patient will secrete 20 oz., and on others as little as 4 oz. Most patients would prefer an operation, even a dangerous and tedious one.

If the practitioner succeeds in so increasing the muscular strength of the bladder as to overcome the increased prostatic resistance, surely he is dangerously near the production of back-pressure with fatal results to the kidneys?—I am, etc.,

O. CLAYTON-JONES, M.B. Oxon.

Silverton, nr. Exeter, March 14th.

THE DROOPING SHOULDER SIGN OF PHTHISIS.

Sir,—Let me reply briefly to the little discussion of the paper entitled as above. The first participator says I mention Krönig, but not his "isthmus of resonance." Hardly necessary, perhaps, for that is by way of being a

classic sign, and every recent textbook, British or other, has it.

The second gives a British book in which, he states, the drooping shoulder phenomenon is fully described. I fear I cannot agree. There is no mention of *unilateral* drooping. What is described is sinking of both shoulders due to the long familiar fact that the *thorax paralyticus* has a position of expiration. Nothing is said of one scapula lying lower than its fellow, nothing of this asymmetry being probably due to the atrophic trapezius allowing it to sag; nothing of the probability of such atrophy being an end-stage of Pottenger's muscular spasm and subsequent pulpy degeneration; nothing of the smaller nipple on the affected side confirming the theory of nervous origin of the atrophy by pointing to a possible trophic influence. As there are four lines on lowering of the nipple I do not think the author can have read Krönig's untranslated little masterpiece in the *Deutsche Wochenschrift*, or his ready mind would have appreciated the precedence given there to the drooping scapula over the lowered nipple. In this exegesis I am confirmed by his own entry in the discussion. He talks only of lowering of the external end of the clavicle, which he now associates with advanced or extensive disease, citing Walshe to the same effect. Thus it might now possibly be unilateral, although we are left in the dark as to that; but there is nothing even implicit to be gathered as to a connexion with muscular atrophy. In truth, changes in thoracic conformation from advanced lung disease are another thing altogether: witness the frequency of shoulder drooping with clinically early lesions or with the hilus affection of children. Since the bibliography of his book has not a single reference to a German or Austrian paper in the original while, on the other hand, nearly a third of the articles in it are by Scotsmen, one of them mentioned repeatedly, my withers are not sore under his strictures as to authors and nationalities proper to quote. For my part, I cited the chief relevant writers—Krönig, whom we have heard about; Banelier and Roepke, the English translation of whose book is on every tuberculosis officer's shelf; Schröder and Blumenfeld, authors of the fullest work on phthisis-therapeutics in existence; and the American Pottenger, whom my third critic also cites. To *approfondir* a subject one must forget geography, and that mendacious goddess Politics.

The fourth one, I fear, with every wish for an amicable summing up, I must characterize as another confuser of *thorax paralyticus* with a unilateral phenomenon; as is surely plainly apparent. Even if he were not, two words are a smallish basis for a priority claim. We are not all as easily satisfied as M. Jourdain was when they told him "Bel Men" meant such a lot of things.

The "drooping shoulder" seems always to excite interest. Readers might therefore care to turn up *The Lancet* for July, 1920, where I have traced the analogy with muscular spasm and atrophy in osseo-articular tubercle, and in some cases of scrofula.—I am, etc.,

Barnsley, March 11th.

W. C. RIVERS.

THE CURE OF HAEMORRHOIDS WITHOUT OPERATION.

Sir,—I fear I must ask you to allow me to trespass upon your space again in order to reply to Dr. Lyth's letter in the *Journal* of March 12th. I do not know whether to take his opening remark, in which he accuses me of being a physician and not a surgeon, as a compliment or the reverse, but it is typical of the inaccuracy of observation which he shows all through his letter.

Dr. Lyth admits that my views as to the essential differences between external and internal haemorrhoids are assumed by most authors. But he goes on to quote from Walsham and Spencer's book on *Surgery* to prove that "most authors" are incorrect. This little student's book is hardly one to which to refer in a scientific discussion, and Dr. Lyth is forced to make a very "tall" assumption to support his theory that an internal pile may be converted into an external one. The quotation to which he refers is merely to the effect that some piles are "covered in part with skin and in part with mucous membrane." I cannot see why Dr. Lyth should assume from this that the authors meant to imply that internal piles may ever become completely covered with skin and shift their base from above the anal valves to

the skin outside the bowel, which is what he has to do to show that internal piles may become external. He goes on to mention that Keen describes skin-tags as "false piles," and asserts that these skin-tags are "cured" internal piles. I think that most authors—and certainly most authors of books on rectal surgery—are agreed that these skin-tags result (1) from thrombosed external piles, which have subsided, and (2) from the subsidence of oedematous folds of skin around the anus, which are so commonly associated with—but which are altogether separate from—strangulated prolapsed internal hæmorrhoids. Over and over again I have seen these oedematous skin folds appear after carelessly performed stretching of the anus, and also in cases of semi-strangulated prolapsed piles. These piles can be reduced in most cases, but after their reduction the swollen folds of skin remain, and, after the inflammation and oedema have subsided, they remain as skin-tags. The internal piles remain also (unless operated upon or otherwise treated), and it is obvious, therefore, that the tags are not the external "remains" of internal piles, because the internal piles are still there also.

I can assist Dr. Lyth when he wonders what an "internal pile outside the anus still covered with mucous membrane and yet cured, looks like and feels like." An internal pile cannot be outside the anus covered or not with mucous membrane and yet cured. Its cure can only be assumed when no pile can be seen *inside* or outside the anus on examination with the speculum and otherwise. The subject of his bewilderment is a confusion of ideas and a contradiction of terms.

It may be that Dr. Lyth has watched more cases of piles than I have, but in view of my three years' experience in the out-patient department of St. Mark's Hospital, and a private practice which has included a very large proportion of rectal cases—and especially of cases of hæmorrhoids—I am disposed to doubt it. I have seen skin-tags arise over and over again in the ways I have described above, and most writers on rectal surgery describe the same processes; but I have never seen an internal pile acquire a skin-covering and an external attachment, nor can I find any writer, other than Dr. Lyth, who has observed such an extraordinary process. When Dr. Lyth goes on to inform us that the glans penis in the uncircumcised is covered with mucous membrane, one realizes that his powers of observation are not very accurate!

I should not have thought it necessary to assert again that internal piles which have never prolapsed may give rise to serious symptoms, had not Dr. Lyth tried to prove the contrary. It is useless for him to repeat his statement that "so long as it is inside and remains inside—even during defæcation—it does little harm." I assume that internal piles inside the anus may bleed, because I have seen them, with the aid of a speculum, actually bleeding and the blood collecting inside the rectum—and this not seldom but very commonly. Such bleeding piles are often far too small to reach down as far as the anus, and when the patients assure me they have never prolapsed, I prefer to believe these patients and my own eyes rather than Dr. Lyth's very dogmatic contradictions.

I cannot follow Dr. Lyth's argument about the shape of the stomach as seen in *x*-ray examination, because I cannot see what it has to do with what Dr. Lyth assumes is the normal prolapse of the rectal mucosa during defæcation. I have sat behind a horse and am well aware that in that animal there is some prolapse of mucous membrane from the anus during defæcation: but the human rectum does not prolapse during defæcation in a normal individual, though of course piles often do prolapse during defæcation and become reduced spontaneously. In fact, I make a note in every case as to whether the piles are spontaneously reducible or have to be reduced digitally. It is unnecessary to give a patient an enema and to make him strain in the squatting position to demonstrate the presence of piles, if one possesses and knows how to use a good speculum. This process of enema and the squatting posture, suggested according to Dr. Lyth by Keen, has obvious disadvantages in private practice, especially if the patient is a lady. I fancy a speculum gives more accurate results and less offence to delicacy.

Dr. Lyth next asks how a pile can bleed externally in any quantity unless prolapsed. It cannot do so, but it

frequently does bleed into the rectum in large and even dangerous amounts. I have seen cases where the accumulated blood has acted as an enema and has been expelled suddenly together with faeces, leaving the patient almost pulseless. And yet in some of these cases the piles had never been down and could not be forced down by straining, even after the enema that was necessary to get rid of the remainder of the blood and faeces in the rectum, and so to inspect the piles *in situ*. Certainly in cases where the piles do prolapse and where bleeding takes place outside the anus, the blood is often small in amount and arterial in colour—in fact, the bleeding is nearly always from small arteries. Dr. Lyth will assuredly come across cases in which there has been no temporary prolapse and there has been serious bleeding nevertheless.

Dr. Lyth charges me with distortion in stating that a patient who has undergone his treatment must afterwards wear a pad and powder the piles frequently. I made no such statement. Quoting from his article, I said that on his own showing it will be some six weeks before the piles can be spontaneously reduced, and that—again according to Dr. Lyth—only then will he be in a fair way towards being "cured." I went on to write: "Meanwhile, and even afterwards, he has to wear a pad, to powder his piles frequently . . ." If Dr. Lyth will refer to his paper he will see that he wrote that it would take two or three weeks for the piles to be sufficiently shrunken to return inside the bowel during the night; after a further lapse of two or three weeks the prolapse is so readily reducible that he may dispense with the pad at night, and he is "then in a fair way to being cured . . ." and he is wise to have calamine and a pad available." I do not think that what I wrote is a distortion of this description, but I do think it is a distortion on Dr. Lyth's part to try to make me out as having said that the pad and calamine must be used after the end of the treatment—presumably ever after; I said no such thing, and therefore plead not guilty to the charge Dr. Lyth makes against me.

On the other hand, I for my part accuse Dr. Lyth of distortion of my description of the results of the treatment by injection when he says that I implied that the result as far as symptoms are concerned is not instantaneous. I wrote that in the very large majority of patients both bleeding and prolapse have disappeared from the moment of the first injection. My criterion of the *cure* of piles is not their disappearance from view into the rectum and the cessation of symptoms, but the complete absence of piles on inspection of the interior of the rectum with a speculum. To ensure this, an average of four injections at weekly intervals is necessary; sometimes one attains this result with two and sometimes as many as six are necessary. Dr. Lyth calls a *maximum* of six "injecting for an indefinite period," and tries to make out that the symptoms continue all that time, which, as I have said, is a distortion of what I wrote.

A very conservative estimate of the number of injections I gave at St. Mark's Hospital would be 1,500, and I suppose that I have treated not less than 1,000 cases in my private practice. Amongst these there have been no cases of pyæmia or of hepatic abscess, and I have not heard of any case of this sort in the practice of others. I have heard of pyæmia in cases treated by operation in the old septic days, and also of cases of abscess and pyæmia following upon sloughing of strangulated piles, left untreated or "treated" without reduction by so-called palliative measures. I can well imagine that if injections were given with septic instruments and without careful attention to details such complications might arise; but the same may be said of operative, palliative or any other treatment. I may add that I have many times treated patients by injection after several unsuccessful operations by other surgeons, and that some of these were included amongst the 83.4 per cent. successful injection cases of over three years' standing to which I referred in my former letter.

Let me ask Dr. Lyth to get a Kelly's speculum and examine some of his so-called cures with it in order to ascertain whether they still have piles or not. Let him also give us some figures as to the number of his cases and the percentages cured according to the criterion of whether they still have piles inside the rectum. This evidence is essential in order to form a judgement of the value of his treatment.—I am, etc.,

London, W.C., March 12th. ARTHUR S. MORLEY, F.R.C.S.

"CHANGE OF AIR."

SIR,—The very interesting article by Mr. Frank Coke in the JOURNAL of March 12th, and his demonstration that other things than air are involved in the therapeutic influence of what we call change of air, prompts me to recall a case I saw long ago. A lady under the care of Dr. George Hunter suffered from a chronic irritation on her hands which became intolerable but at once disappeared when he sent her away for change. She came home full of gratitude, but the rash began to develop itself again immediately. At this time *Prunella obconica* was discovered (by Dr. W. G. Sym, I think) to be a cause of skin irritation, and Dr. Hunter found she had it in her greenhouse. He banished it, and she was free of the rash ever after. This was years ago, but I have always felt since that the easy ascription of disease to climate was a mistake, and that it was not climate, but associated agencies, which caused the so-called "climatic diseases," and I fancy every one thinks so now. Mr. Coke's research gives prospect of cure to many sufferers.—I am, etc.,

Southsea, March 13th.

W. E. HOME, M.D.

RISKS AFTER OPERATIONS ON TONSILS AND
ADENOIDS IN OUTDOOR CLINICS.

SIR,—I have been so interested in the correspondence in the JOURNAL on this subject that I cannot refrain from giving my experience in the special department of a London general hospital—Charing Cross—where the number of beds is seriously limited.

The following routine is adopted: Printed directions for the preparation for operation and treatment are given, and, if that indispensable hospital officer the almshouse and her staff find that the patient's home is poor, unsuitable, and not within an easy journey to the hospital, admission is recommended. The operation is performed at 8.30 a.m., and while the child is being prepared the temperature is taken, and if it is above 99° F. operation is postponed. After operation the patient is kept warm and quiet until 12.30, and, if found well enough after inspection by the medical officer, a piece of gauze is fixed over the month and the patient sent home. In most cases the mother willingly spends a few shillings on a taxi. The use of an ambulance car was offered, but it was found to be impracticable, as the children lived at all points of the compass. A district nurse visits the patient next day when necessary.

We came to the conclusion that if these patients were to receive any benefit from admission, they must be kept in for at least three days, and it is better for the child to go home a few hours after operation than on the next day after it has had a restless night and the usual reaction with its accompanying temperature.

This routine has been carried out for fifteen years with such good results and without a single serious disadvantage that I am convinced that under the above conditions the hard-and-fast rule that all cases of this operation should be admitted is unsound and impracticable. The question of admission should be left to the discretion of the individual operator, who, with a little tact, can obtain any and every thing for his majesty the child.—I am, etc.,

London, W., March 11th.

EDWARD D. D. DAVIS.

THE FALL IN THE TUBERCULOSIS DEATH
RATE.

SIR,—It is to his little controversy with me that Dr. Davies's letter (February 26th, p. 322) refers. It is so earnest, and its fallacies so pathetic, that criticism may seem ungracious. But he will allow that truth is to be sought at all costs; and that a man may be seeking the same aims with himself who tries to find out what are the limits within which the State can do good, without which it must do harm.

He and I start from a common basis in regard to the effect on real wages of Insurance Acts and the like. As he implies, they lower them. But, he maintains, such measures may do much to stamp out phthisis.

It would be difficult to find a more crushing refutation of his position than has been afforded by the seven years 1913-1919. To begin with, destitution, on which he laid and lays much stress, was abolished during the war, and much diminished, as he said, before the war. The death

rate went up. State agencies were working at the minimum of impediment up to 1915. The death rate rose. After that they worked with a gradual increasing impediment up to the maximum in 1918. According to the Registrar-General, but for the influenza epidemic at the end of 1918, it would have been obvious that the rate was declining in 1918; the decline was patent in 1919.

Dr. Davies rather plumes himself on his prophecy, vague and faltering though, on his own showing, it was. Let me tell him what were the prophecies of men of my school. In 1912 we predicted a rise in 1915, due to the Insurance Act. That came true. In 1915, seeing how money wages were outstripping prices, and assuming, as we had learned to assume, that the war would last for so long, we predicted a fall in 1918. The Registrar-General cannot be accused of standing on the same platform with me, and he says that prophecy came true also. If history goes for anything, the momentum of that fall will last another year or two. But the question of wage rate is to-day extraordinarily complex. No one can predict its course with any confidence. Personally I believe that real wages are falling, and must fall considerably in the near future. If so, one fears that we have to look to a rise in the rate in 1923.

But in any case the fall in 1919 (which is partly unreal, for clearly many deaths occurred in the last quarter of 1918 which normally would have fallen in 1919) of phthisis mortality is short of that of 1913. It is humiliating to find that we have made no progress in six years; nay, if I take a single year—namely, 1918 (as he does)—none in twenty-six years. But my point was, and is, the slackening of the rate of fall from 1895, since statesmen discarded Gladstonian finance. If the Gladstonian rate of fall had been maintained, in 1919 the death rate would have been some 400. It was some 1,000; and that only after a little jugglery.

I submit that there is only one possible explanation of the facts of the war—namely, the raised standard of living among the largest section of the community, the borderland class. I am constantly seeing statistics that show that after the momentum of the rise due, finally, to the Insurance Act, had died down, the insurance class of patient died less fast than before, though in 1917 and 1918 conditions were at their worst. On the other hand, classes which had been well-to-do had their standard lowered, and died faster. It is highly significant, for example, that half the increase in deaths in 1918, were asylum deaths—that is, of people who would not feel the fluctuations in wages rate, but would be specially obnoxious to debilitating influences, such as inferior food, though again they would be exceptionally fortunate in the degree of official supervision they enjoyed.

If Dr. Davies is to prove his point, it is imperative that he should adduce instances of a fall in the rate after a fall in real wages. I have sought earnestly and cannot find one, though I can show scores where a fall in rate has been heralded by a rise in wages, or a rise in rate by a fall in wages. All the benefits he aims at obtaining for the poorer classes—with the exception of the army of officials—come automatically if the rate of wages rises. Indeed, he himself lays stress on a raised standard of living. It plainly cannot be raised unless wages are also raised. The official naturally sees the result for good on individuals of measures of the kind we were discussing; he ignores, because he does not see, the results for evil on the mass. But we, who go habitually and intimately among the poor, know that for one relieved twenty suffer.

The State has had to compete with private capital for labour, and so wages have been raised by help of loaned capital to an undreamed-of height. That cannot go on. But the process can be wholesomely imitated, and in one way only—the way of Mr. Gladstone and the Manchester School. Let the State and municipality stay their mischievous hand. I am, etc.,

Rayleigh, Essex, March 4th.

B. G. M. BASKETT.

THE PREVENTION OF VENEREAL DISEASE.

SIR,—In considering this problem we cannot disregard the facility with which brothels are established and conducted in London.

As a member for six years of the Legal and Parliamentary Committee of the Council for this borough realized (1) that this evil is extensive and carried on by

both women and men; (2) summonses, though supported by good evidence, were constantly dismissed by one magistrate, though the same class of evidence in another court secured conviction and a fine; (3) as a rule the punishment was inadequate—imprisonment was rarely inflicted, and only after a second conviction; (4) persons found guilty and evicted from one locality would later carry on the same vile occupation elsewhere; (5) many of the proprietors of such "disorderly houses" were aliens. Our council passed a resolution to the effect that increased penalties should be awarded for the offence, and that aliens found guilty should be imprisoned and subsequently deported. This resolution was sent to our senior M.P.

With regard to instruction of adolescents in this matter, as a mariner is not sent to navigate a dangerous coast without a chart so a warning should be given to the young at puberty of this peril in the voyage of life. A father cannot hurt his boy's sensibility by reading with his son the awful warning in Proverbs vii.—I am, etc.,

Paddington, W., March 5th. HENRY H. STURGE.

EPILEPSY CONSIDERED AS A SYMPTOM.

SIR,—In your issue of January 15th Dr. Alfred Carver relates two cases illustrating the psychic origin of some cases having the epileptiform convulsion as chief symptom. As a psychic origin would appear to be more common than was at one time believed, it is well that cases illustrating it should be recorded, and I add a few cases which have recently come under my observation in private.

Case 1.—A man, in easy financial circumstances, aged 32, married, with two children, was sent to me by his doctor. He complained of dizziness and "faints," with loss of consciousness or "fits" as his relations called them. He had been a lieutenant in a non-combatant corps; he had some months' service in France, and was "windy" more or less all the time, when a small piece of missile, hardly denting his "tin hat," supplied the final touch to his breakdown. In a hospital in France he, amongst other things, walked in his sleep, and he came to a neurological hospital in London while air raids were still common. Ultimately he rejoined his unit on home service and was in due course demobilized. After some time in civil life he began to have dizzy turns, and often, if he merely thought of getting a dizzy turn, he would get one, his face then becoming suffused. Periodically he would have what appeared to be a fit; he would fall down suddenly, sometimes without warning; this would be followed by amnesia for the whole affair and the events recurring thereafter. By the same methods as described by Dr. Carver, I found he had considerable amnesia for parts of his war experience, and in particular had repressed the memory of his "baptism of fire" and its "affect." This "affect" was liberated, not at the time of recovery from this amnesia, as one usually expects, but in a dream of the same experience, which I suggested he would have, that same night. Following that, he said he felt a different man, and so far as I know he has had no more fits, but should he have further secondary repressions they will have to be dealt with in the same way.

Case 2.—A machine gunner from a military family joined the army at the age of 16. He was an excellent fighter, covered with scars of wounds. At intervals, since he was discharged on account of wounds, he had had attacks which conform to most people's ideas of an ordinary epileptic convulsion with an aura; the fits occur at the same time of day as when he was wounded, just prior to his leaving the trenches for a rest, and the "aura"—a peculiar drumming noise in the head—is identical with the head noise which he experiences at the commencement of a fit. He was certified by a medical referee as suffering from epilepsy. Release of his repression, with an abreaction, has led to a cessation of his fits.

Case 3.—A young man, now aged 23, shy and reserved, during the stresses connected with puberty, about seven years ago, had what appeared to me to be an ordinary epileptic convulsion after an incident which strongly aroused his emotions. Since then he has had a number of such attacks at long intervals. He always gets them while at home, after emotional stress, such as a difference with his father, or the like. Although he has driven his father's cart through the streets for years, he has never had a fit under circumstances which would endanger his life. These facts would seem to point to a psychogenic origin of his fits, but I have had no opportunity of a psychological analysis.

Case 4.—A boy, now aged 6 years, an only child, very sensitive and with a strong imagination, was taken to a pantomime at the age of 3, and was frightened by an actor dressed up in a wild animal's skin. The following day he had a fit, in which he lost consciousness for a short time; his chin coming in contact with the table, was cut, necessitating a couple of stitches. He had many recurrences of these attacks resembling *petit mal*, during a year or more, the falls on the chin opening it several times. The parents, or rather neighbours, being restive, he was seen by a distinguished neurologist, and developed one of his attacks in the hall of this gentleman's house. He considered the attack to be, as I did, of the nature of *petit mal*, and prescribed a modern form of bromide medication, but after a couple of bottles the parents gave it up. I directed the

father to find out if possible any incidents which had made a strong impression on the child's mind and to allay any fears connected therewith. The pantomime incident cropped up, and the father did as directed; whether this was *post hoc* or *propter hoc* I cannot say. Soon after, the fits entirely ceased; but when I happened to see the mother recently she volunteered the information that in the following year after the fits began the boy had gone to the pantomime again, and had a fit the following day.

In this last case the second pantomime revived the emotion connected with the first, and the dissociation of consciousness led to a fit on the following day. The main point for patient and parents is that the patient has had no fits for more than a year.—I am, etc.,

W. CAMPBELL ANDERSON,
Physician, Neurological Clinic, Ministry of Pensions, Cardiff;
late M.O. Maghull Military Hospital.
Cardiff.

THE POSITION OF THE ARMS IN BREECH WITH EXTENDED LEGS.

SIR,—I have kept an account of my breech cases (hospital and private), 62 in number. Of these, 23 had extended legs, and in 15 of these the arms had to be brought down as they were extended also. In 11 the arms only were extended. I have found that there was no danger of the arms being extended by pulling on the breech, provided the pulling was done only during uterine contraction. I always verify the position of the arms when the umbilicus appears.

One interesting breech case with extended arms and legs had a spina bifida; first the legs and then the arms were brought down. There being no progress, the head was examined and found to be large. The cord had ceased to beat, and forceps applied to the after-coming head would not lock. In view of the probability of hydrocephalus, the spina bifida was opened, a catheter passed up, and the fluid from the head run out. The next uterine pain completed the birth without assistance.

Extended legs offer no difficulty, and need not be brought down in cases of sacro-posterior breech. I have watched four cases deliver themselves easily without help.—I am, etc.,

L. GORDON HOPKINS, M.D. Lond.
Westcliff-on-Sea, March 7th.

SIMPLE GOITRE IN SCHOOL CHILDREN.

SIR,—I agree with Dr. W. A. Lethem's statement (March 5th, p. 367) as to simple goitre in school children. For a number of years I have observed that a considerable number of children show evidence of slight deficiency of the thyroid secretion, either with or without coexistent enlargement of the thyroid gland. This enlargement when present is in many cases a compensatory one on the part of the gland to overtake its work, and subsides in many cases when tablets of thyroid extract are given.

Children Examined in Smethwick, 1920.

	Boys.	Girls.	Total.
Children examined	1,618	1,891	3,509
Enlarged thyroid gland	60	170	230
Showing symptoms of hypothyroidism without any definite enlargement of gland	13	24	37

In a junior technical school 260 boys between the ages of 13 and 16 were examined, and of these forty-eight showed enlargement of the thyroid gland and twelve had symptoms of hypothyroidism without enlargement of glands. It was noticeable that the majority of these cases were much undersized and invariably below the average in physique. As Dr. Lethem points out, the signs of mild hypothyroidism in children are difficult to detect unless they are looked for. If the diagnosis is correct these cases respond definitely and show improvement within three or four weeks on small doses of thyroid extract. I am accustomed to commence with the average child of 10 with gr. ½ three times a week, increasing as required. In these cases the mothers are urged to give the children plenty of vegetables and to steam them instead of boiling. In some cases where anaemia is marked or there is a scrofulous history, a few drops of tincture of iodine in milk is given.—I am, etc.,

J. BELL FERGUSON,
Smethwick, March 7th, Medical Officer of Health.

Obituary.

ERNEST HOOK BUCKELL, J.P., M.R.C.S., L.R.C.P.,
Consulting Physician, Royal West Sussex Hospital.

DR. E. H. BUCKELL, who died at his residence in the West Pallant, Chichester, in his 69th year, was the second son of the late Dr. Leonard Buckell, of the same city, and came from a generation of members of the medical profession. He was educated at Epsom College, after which he had a distinguished career at University College Hospital, and obtained the diplomas M.R.C.S., L.R.C.P. and L.S.A. in 1875. Thenceforward he practised in Chichester and the district, succeeding his father as medical officer of the Bishop Otter Memorial College and of the Chichester Poor Law Institution. He enjoyed also an extensive private practice. For over thirty years he was honorary physician to the Chichester Infirmary, now the Royal West Sussex Hospital. On his resignation, in 1919, he was appointed hon. consulting physician. He founded the x-ray department at that hospital, and its present state of efficiency is due to his work of some years ago.

Dr. Buckell was a great supporter of the British Medical Association, and in the year 1919 was President of the Chichester and Worthing Branch, and as such entertained the members at his house in July of that year. As a colleague he was exceptionally agreeable. His sympathies were always extended to the poor people of the city, and on this account he will be greatly missed. His personal relief to people in the district was extensive and his devotion to duty was great. Dr. Buckell took a keen interest in public affairs, and was for many years a member of the City Council and also a Justice of the Peace for the city. His spare time was given up to carpentering, in which art he was an expert. To mourn his loss he leaves a widow and four daughters (one of whom married Dr. Walter Dick, who succeeds to his practice) and two sons, Dr. Ernest Buckell, who practices at Newport, Isle of Wight, and Dr. Aston Buckell, who is assistant bacteriologist at Durham University.

DR. HUGH A. McCALLUM, Emeritus Dean of the Western University Medical School, London, Canada, died of pneumonia on January 25th after a brief illness. He was born near London, Ontario, in 1860, and was educated at the Collegiate Institute, St. Thomas, and at the Western University Medical School, from which institution he graduated in 1886, winning the gold medal. After acting as lecturer in biology for the session 1886-7, he proceeded to Johns Hopkins University, where he studied physiology under Newell Martin. On his return to his native town he was appointed professor of physiology, a position he held for the succeeding ten years. During this period he wrote extensively on physiological topics, his papers being marked by much originality and philosophic grasp. He was subsequently appointed to the chair of medicine and continued in that post until last year. In 1900 Dr. McCallum came to England and studied at various London hospitals, obtaining the membership of the Royal College of Physicians of London in the following year. In 1913 he was elected Dean of the Medical Faculty of the Western University, and under his influence the medical school entered on a new era of prosperity; full-time professors were secured for the laboratory departments, and the project for obtaining new buildings assumed definite form. The commodious and efficient medical laboratories now nearing completion represent the culmination of his efforts in behalf of medical education in Western Ontario. He was appointed emeritus dean in 1919. In 1901 he married Miss Mary Burnard; he is survived by his widow, three sons, and one daughter. The high regard in which Dr. McCallum was held, both professionally and personally, made him a great force, not only in his own community, but in Canada generally. His death was deeply mourned by people in all stations in life.

DR. DONALD JOSEPH MACAULAY of Halifax, who died on March 8th, received his medical education at the University and the school of the Royal College of Surgeons of Edinburgh. He took the triple Scottish qualification in 1890 and the M.D.Brux. in 1897. He was a native of the Outer

Hebrides, but had resided in Halifax for thirty years, where he had a large practice and was greatly esteemed by his patients. He took great interest in the work of the St. John Ambulance Association, of which he was a life member. He was a member of the British Medical Association and had held the office of President of the Halifax Division. One of Dr. Macaulay's chief hobbies was to collect Whistler's etchings, of which he had an excellent collection. He is survived by his widow, three sons, and two daughters.

WE regret to announce the death from pneumonia, at the age of 67, of Dr. JOSEPH ERNEST BULLOCK, of St. Leonards-on-Sea, which took place at Northampton on March 4th. Dr. Bullock was educated at University College Hospital; he qualified M.R.C.S. and L.S.A. in 1878, and obtained the M.D.Brux. in 1880. He was subsequently resident medical officer at the Western Medical Dispensary, London, and house-surgeon at St. Peter's Hospital. After practising for many years at Ladbroke Grove, W., he took up the special study of tuberculosis, and he was for some time on the staff of the Eversfield Chest Hospital, St. Leonards-on-Sea. During the later years of the war Dr. Bullock was employed as acting tuberculosis officer for the county of Northampton. He translated Cornet's *Skrofulose* with marked success, and he wrote numerous articles which were published in the medical journals. He was recognized by all who knew him as a man of the highest character, with a kindly nature, and a varied and extensive knowledge of medical work.

THE untimely death of Captain (temporary Major) EDWARD RANDOLPH ARMSTRONG at Quetta at the early age of 36 removes from the I.M.S. one of its most capable and popular officers, and one who—health permitting—would have undoubtedly gained high honours and rank. Armstrong had a brilliant academic career. He took the Liverpool University M.B., Ch.B. degrees with honours in 1907, and subsequently the M.D. while at home on sick leave. In 1909 he took the D.T.M.Liver. and in 1910 the D.P.H.Camb. with "distinction" in three of the four subjects. Joining the Indian Medical Service in July, 1911, he won all the prizes open in his term to the I.M.S. and the I.M.S. and R.A.M.C. combined. At the beginning of the war he was invalided to England on account of ill health. Having been passed fit for duty in India—but to his sorrow not for general service—he returned to India in 1916, and was appointed D.A.D.M.S. (Sanitary) at Army headquarters. The work entailed by this appointment he carried out in a highly efficient manner for nearly four years. After a few months spent in England he was appointed D.A.D.M.S. (Sanitary) of the 4th Quetta Division, and took up his duties in December, 1920. A colleague writes: "Though a rapid worker everything he touched showed meticulous care. Often in ill health, he never allowed personal affairs to interfere with the strenuous and responsible work he was called upon to do. He never worried—difficulties only added zest to his work. Kind-hearted, generous, and lovable, the many friends to whom he endeared himself will long remember him."

THE death has occurred at Bratton, Wilts, of Dr. CHARLES A. GATLEY, at the age of 31. The son of Dr. H. R. Gatley, of Kingston-on-Thames; he was educated at Marlborough and Guy's Hospital, where he held the post of house-surgeon. On the outbreak of war he went as house-surgeon in charge of Mrs. Hall-Walker's (now Lady Wavertree) hospital at Regent's Park, and a year later went to France, attached to the East Kent Regiment. It was while at Cherisy that, in 1917, he was very severely wounded, and the results brought about his early death. He was wounded while going up to the firing line, because the stretcher cases were not coming down quick enough. In April, 1919, he entered into partnership with Dr. Trevor Shorland, of Westbury. Dr. Gatley was only recently appointed medical officer for the Bratton district under the Westbury Guardians, and was a member of the Pensions Board for Wiltshire. The burial took place at Bratton, Dr. Bond of Trowbridge representing the Wiltshire Branch of the British Medical Association.

The death is announced at Ballarat, Australia, on January 24th, of Dr. WILLIAM MORRISON, youngest son of the late Mr. Donald Morrison, LL.D., a former Rector of Glasgow Academy. Dr. Morrison graduated in arts at Glasgow University in 1877, and in medicine in 1881, taking the degree of M.D. three years later. He was senior honorary physician of Ballarat Hospital, and physician accoucheur to Ballarat Female Home. He held the rank of major in the Australian Army Medical Corps.

DR. JAMES ARTHUR WILLIAM CULLEN died at the British Station Hospital, Jhansi, India, on January 16th. He was educated in Dublin, where he graduated B.A., M.B., B.Ch., and B.A.O., in 1917, and immediately took a commission in the Special Reserve of the R.A.M.C., being promoted to captain on October 10th, 1917. He had served in India. On being demobilized last year, he entered the service of the Great Indian Peninsular Railway, and at the time of his death was district medical officer at Bina.

Universities and Colleges.

ROYAL COLLEGE OF SURGEONS OF ENGLAND.

AN Ordinary Council was held on March 10th, with Sir Anthony Bowlby, President, in the chair. Diplomas of Fellowship were granted to nineteen candidates found qualified at the recent examination. Licences in Dental Surgery were granted to thirty-eight candidates found qualified at the recent examination. Mr. H. J. Waring was appointed Bradshaw lecturer for the ensuing year.

The Dentists Bill.

The following report of the Dentists Bill Committee was presented to the Council:

As requested by the Council on February 10th, 1921, the Committee has taken into consideration the bill to amend the Dentists Act, 1878, presented to Parliament by Dr. Addison, and has consulted the Dental Section of the Board of Examiners in Dental Surgery in reference thereto. So far as the Committee has been able to ascertain, the bill, as a whole, is approved by most members of the dental profession. There is, however, one provision in the bill which meets with some amount of opposition—namely, the provision to admit to the *Dentists' Register* without any kind of test persons who for five years immediately preceding the commencement of the Act have been engaged in the practice of dentistry. It is strongly felt by many that no one, who has not passed some sort of examination as a test of fitness, should be put on the *Dentists' Register* itself, and that vested interests would be sufficiently met by placing those who have been in practice for five years or more on a separate list, appended to the *Dentists' Register*, with the title of dental practitioner, and with the right to pass to the *Dentists' Register* if they submit themselves successfully to the prescribed examination. At the same time it is recognized that it might be undesirable to adopt this course unless those placed on the separate list could be made subject to the same control as those on the *Dentists' Register* itself. There are some provisions in the bill to which the Committee thinks it desirable to call the attention of the Council. In addition to the fee for original registration, the Board which it is proposed to set up will have power to charge an annual fee, not exceeding £5, for the retention of a name on the *Register*. Further, while the actual order for the erasure of a name from the *Dentists' Register* will be made by the General Medical Council on a report from the Board, the inquiry in connexion with the removal from or restoration to the *Dentists' Register* will be held by the Board. As any name erased from the *Dentists' Register* on account of crime or disgraceful conduct must also be erased from the list of licentiates in dental surgery or dentistry of the medical authority of which such person is a licentiate, it follows that a licentiate in dental surgery of the Royal College of Surgeons may be deprived of his licence after judgment by this Board on which the College is not represented. As regards the constitution of the Board, the Committee finds that, as at first constituted, 9 of its 12 members will be appointed by Government authorities, and that both in its initial and its permanent form no representation is given to the medical corporations, and not less than one-half of the seats on the Board are allotted to representatives of Scotland and Ireland. The want of proportion in this arrangement may be gathered by reference to the official statistics published in the *Dentists' Register* for 1920, which show that 80 per cent. of the persons

whose names are recorded in the *Dentists' Register* are graduates and licentiates in dental surgery of universities and colleges in the United Kingdom, and that of these approximately 50 per cent. have qualified in England, including 46 per cent. holding the licence in dental surgery of the Royal College of Surgeons of England, 21 per cent. have qualified in Scotland, holding, with two exceptions, the licence in dental surgery either of the Royal College of Surgeons of Edinburgh or of the Royal Faculty of Physicians and Surgeons of Glasgow, and 9 per cent. have qualified in Ireland, all but thirty holding the licence in dental surgery of the Royal College of Surgeons in Ireland. The Committee further note that the Board, both in its preliminary and its permanent form, is to contain three lay members, not being registered medical practitioners or registered dentists.

The Committee thought it desirable to call the attention of the Council to several points in connexion with the bill, but, while unable to regard it as entirely satisfactory, is not prepared to recommend the Council to endeavour to secure any amendments, in view of the general acceptance with which it appears to have been received by a majority of the members of the dental profession.

Election of Council.

A meeting of the Fellows will be held at the College on Thursday, July 7th, at 2.30 p.m., for the election of four Fellows into the Council in the vacancies occasioned by the retirement in rotation of Sir George H. Makins, G.C.M.G., C.B., Mr. J. Ernest Lane, Mr. H. J. Waring, and Mr. F. F. Burghard, C.B. Blank forms of the requisite notice from a candidate and of his nomination may be obtained on application to the Secretary, and the same must be received by him duly filled up not later than Monday, March 21st. A voting paper will be sent by post to each Fellow whose address is registered at the College, on April 5th. Fellows are requested to give notice, without delay, of any change of address, so that their voting papers may not miscarry. We are informed that Sir George Makins and Mr. Ernest Lane will not present themselves for re-election.

UNIVERSITY OF OXFORD.

Osler Memorial.—At a public meeting held in March, 1920, it was decided to raise a fund to establish a memorial to the late Sir William Osler, Bt., Regius Professor of Medicine in the University. The fund has now reached nearly £2,000, and a further list of subscribers will be published soon. Subscriptions may be sent to the Honorary Treasurer, Mr. A. P. Dodds-Parker, B.M., F.R.C.S., 2, Holywell, Oxford.

Diploma in Public Health.—The Board of the Faculty of Medicine gives notice that at the examinations for the diploma in public health in Michaelmas Term, 1921, and afterwards, the first part of the examination will comprise the application of chemistry and physics to general hygiene, and general pathology with special relation to infectious diseases. The second part will comprise practical pathology and bacteriology, general hygiene, the laws relating to public health, sanitary engineering, and vital statistics. The examination in Michaelmas Term, 1921, will be conducted in accordance with a time-table published in the University Gazette for March 9th, 1921 (Clarendon Press, Oxford, 3d.). The effect of this announcement is to remove from Part 2 to Part 1 the examination in systematic pathology and bacteriology, but to retain in Part 2 a practical and *vice versa* examination in those parts of the subject which are most closely related to public health.

Degree Days.—The following degree days are announced: Saturday, March 19th, at 10 a.m.; Thursday, April 28th, Saturday, May 21st, Thursday, June 16th, Thursday, June 23rd, and Saturday, July 9th, at 2.30 p.m.

ROYAL FACULTY OF PHYSICIANS AND SURGEONS OF GLASGOW.

The following have after examination been admitted as Fellows of the Faculty: S. S. Barton, R. T. Grant, N. Morris, J. Russell.

The Services.

THE following members of the Scottish Women's Hospitals for Home and Foreign Service have received the King's permission to wear decorations of the Order of St. Sava of the classes conferred upon them by the King of the Serbs, Croats, and Slovenes in recognition of their services to the Serbian sick and wounded in the late war:—*Fourth Class*: Miss Beatrice Anne McGregor, M.B., C.M. *Fifth Class*: Miss Lilian Mary Chesney, M.B., Ch.B., Miss Janet McVea, M.B., C.M., Miss Elizabeth Brook, M.B., Ch.B., Miss Catherine Louise Corbett, M.B., Ch.B., Miss Janet Stewart Laird, M.B., Ch.B.

DEATHS IN THE SERVICES.

LIEUT. COLONEL ROBERT COBB, Bengal Medical Service (retired), died at Lincoln on January 15th, aged 63. He was born on May 10th, 1852, the son of the late Rev. T. Cobb, of Stockbury, educated at University College, London, and took the diplomas of M.R.C.S. in 1874 and L.R.C.P. Lond. in 1875, and subsequently

the M.D. Brux, in 1886. Entering the I.M.S. on March 31st, 1876, he became surgeon-lieutenant-colonel after twenty years' service, and retired on October 10th, 1906. His whole service in India was spent in civil employ in Bengal, where he held two of the most important stations, Patna and Dabha, successively, and also acted as Surgeon Superintendent of the Presidency European General Hospital, Calcutta. Some years after he retired from the army he entered the service of the British North Borneo Company, under whom he served as Principal Medical Officer and Member of the Legislative Council at Sandakan, the capital of the Protectorate. He had only recently retired and returned home.

Dr. William Frederick Abbott died at Clifton on February 28th, aged 65. He was educated at the Ledwich School, Dublin, and took the L.A.H. Dubl. and the L.R.C.S. Ed. in 1884. Before the war he was in practice at Clapham; he took a temporary commission as lieutenant in the R.A.M.C. on April 7th, 1915, becoming captain after a year's service, and acting major on March 29th, 1918; he was medical officer to the Military Hospital, Lewisham, demobilized a year ago.

Medical News.

ON the recommendation of the Minister of Health, the King has been pleased to appoint Mr. C. L. Forestier-Walker, M.P., to be a Commissioner (unpaid) of the Board of Control, in the place of the Right Hon. Sir W. H. Dickinson, K.B.E.

WE are asked to state that hospitals in the county of London, or within nine miles of Charing Cross, desiring to participate in the grants made by King Edward's Hospital Fund for London for the year 1921, must make application before March 31st to the Honorary Secretaries, 7, Walbrook, E.C.4. Applications will also be considered from convalescent homes which are situated within the above boundaries, or which, being situated outside, take a large proportion of patients from London. Applications will also be considered from sanatoriums for consumption which take patients from London, or which are prepared to place beds at the disposal of the Fund for the use of patients from London hospitals.

A SPECIAL post-graduate course adapted to the needs of the medical man in active practice will be held at the Prince of Wales's General Hospital, N.15, from Monday, April 25th, to Saturday, May 7th. It will include each day demonstrations of clinical and laboratory methods in the morning, and in the afternoon demonstrations of groups of selected cases, and either a clinical lecture or clinical consultation. Demonstrations will also be given in associated special hospitals. A syllabus, to be issued in due course, will be sent on application to the dean.

THE annual conversazione of the Middlesex Hospital Medical Society will be held at the hospital on Monday next, March 21st, at 8.30 p.m. Dr. Charles Singer will deliver an address entitled "Medicine in Ancient Greece."

THE list of products covered by the Dyestuffs (Import Regulation) Act, which has been drawn up in consultation with the Dyestuffs Advisory Licensing Committee, is now available and may be obtained on application to the Board of Trade, Industries and Manufactures Department, Great George Street, Westminster, London, S.W.1.

THE annual meeting of members of the Royal Medical Benevolent Fund will be held at 11, Chandos Street, W.1, on Tuesday, April 5th, at 5.30 p.m.

A SPECIAL meeting of the Röntgen Society will be held at Manchester, on Friday, May 6th, 1921, at 8 p.m., at the University, when Professor W. J. Bragg will deliver a paper and Professor A. V. Hill will give a demonstration of some electro-physiological experiments. On the following day it is hoped to arrange visits to works of scientific interest in the district. As this will be the first meeting away from London, it is hoped that as many members as possible will attend in order to make the meeting a success. The gallery of the Royal Photographic Society of Great Britain has been placed at the disposal of the Röntgen Society during June, when it is hoped that a collection of radiographs, illustrating the different practical applications of x-rays, will be furnished by members of the Society.

THE Wellcome Historical Medical Museum will be closed for redecoration and cleaning from April 1st to the 30th, inclusive.

THE annual debate of the Chelsea Clinical Society, which had been fixed to take place this month, has been postponed till April 19th.

THE house and library of the Royal Society of Medicine will be closed from Thursday, March 24th, until Tuesday, March 29th, both days inclusive.

IN accordance with the terms of the will of the late Dr. Robert Thomas Nichols, the Royal Society of Medicine will offer every three years a prize of £250, open to any British subject, for the most valuable contribution towards the discovery of the causes and the prevention of death in childbirth from septicaemia. Work already published may be submitted provided that the date of publication is subsequent to June 30th, 1921. The first award will be made in 1924, and the application must reach the secretary of the Society not later than June 30th, 1924.

DR. H. E. DIXEY of Malvern, and Major J. R. Williams, T.D., have been appointed sheriffs for the counties of Worcester and Carnarvon respectively.

THE Colston University Society was founded twenty-two years ago, and on the incorporation of the University of Bristol in 1909 it was resolved to apply the funds of the Society to the support of research work within the University. In order to make it clear that the Society exists for the support of research work within the University, and that its funds are devoted wholly to this purpose, the title has now been changed to the Colston University Research Society.

DR. EDMUND BERANICK of Neuchâtel, Switzerland, well known for his work on tuberculin, has recently died.

Letters, Notes, and Answers.

As, owing to printing difficulties, the JOURNAL must be sent to press earlier than hitherto, it is essential that communications intended for the current issue should be received by the post on Tuesday, and lengthy documents on Monday.

ORIGINAL ARTICLES and LETTERS forwarded for publication are understood to be offered to the BRITISH MEDICAL JOURNAL *inve* unless the contrary be stated.

CORRESPONDENTS who wish notice to be taken of their communications should authenticate them with their names—of course not necessarily for publication.

AUTHORS desiring reprints of their articles published in the BRITISH MEDICAL JOURNAL are requested to communicate with the Office, 429, Strand, W.C.2, on receipt of proof.

In order to avoid delay, it is particularly requested that ALL letters on the editorial business of the JOURNAL be addressed to the Editor at the Office of the JOURNAL.

THE postal address of the BRITISH MEDICAL ASSOCIATION and BRITISH MEDICAL JOURNAL is 429, Strand, London, W.C.2. The telegraphic addresses are:

1. EDITOR of the BRITISH MEDICAL JOURNAL, *Ailclove, Westrand, London*; telephone, 2650, Gerrard.

2. FINANCIAL SECRETARY AND BUSINESS MANAGER (Advertisements, etc.), *Articulat, Westrand, London*; telephone, 2650, Gerrard.

3. MEDICAL SECRETARY, *Medisecra, Westrand, London*; telephone, 2650, Gerrard. The address of the Irish Office of the British Medical Association is 16, South Frederick Street, Dublin (telegrams: *Bacillus, Dublin*; telephone, 4737, Dublin), and of the Scottish Office, 6, Rutland Square, Edinburgh (telegrams: *Associate, Edinburgh*; telephone, 4361, Central).

QUERIES AND ANSWERS.

INCOME TAX.

"X. Y. Z." is a retired medical officer and possesses a house in Ireland. If he lets that house furnished for seven months of the year, or for the whole year, is he liable for income tax on his pension or colonial dividends, provided that he then lives outside the United Kingdom?

The facts are unusual, and the point arising does not seem to be precisely covered by a decided case. In our opinion "X. Y. Z." would be liable (a) in respect of income arising in the United Kingdom—for example, the profit on the furnished letting, and (b) on the amount of retired pay or colonial dividends remitted to the United Kingdom. Residence outside the United Kingdom, while another residence is not maintained there, would exempt our correspondent, but it is a settled principle of law that a man may have more than one residence simultaneously, and the possession and occasional use of a furnished house might constitute "residence" for the purpose of the Income Tax Acts.

SEA WATER FOR INTERNAL USE.

"MEDIC" writes: In answer to "Haloid's" query (March 5th, p. 369), there is a preparation of sea water, rendered isosmotic with the blood, which is sterilized and put up in sealed glass ampoules in various quantities. It is usually given intramuscularly, but can be taken by mouth, diluted with ordinary water. It is procured twenty miles from shore at a minimum depth of 30 ft. The sea water is sold by Messrs. A. Nelson and Co., 73, Duke Street, Grosvenor Square, W., and by Messrs. Sumner and Co., 40, Hanover Street, Liverpool. The former's supply comes from France and costs rather more.

LETTERS, NOTES, ETC.

We mentioned last year the foundation of the Southend Doctors' Cricket Club. Dr. A. W. Holtbusen, the honorary secretary, has sent us a report of the season, from which it appears that of the 5 matches played 3 were won. The programme for the coming season includes 10 fixtures.

HERPES AND VARICELLA.

"M.O.H." writes: The interesting correspondence as to the relation of these two diseases has not, so far as I remember, included a case where both affections appeared at the same time in one person. At the end of last summer I was asked to see a man with an eruption on his face which was supposed to simulate small-pox. He had arrived at the house sixteen days previously, and on the thirteenth day had a severe attack of shingles over the shoulder blade and extending around the armpit to the breast. The vesicles were already beginning to dry. On his shoulders, chest, legs, and arms were a very few typical chicken-pox vesicles: the eruption on the face, which was very thick, was just about to enter on the vesicular stage.

SUPERNUMERARY NIPPLES.

DR. EDGAR J. TYRRELL (London) writes: During the last twelve months in 1,000 consecutive examinations of adults I have noted six cases of supernumerary nipples. In one case there were two—one on either side. In the other five the occurrence was on the left side. I was struck by their appearing in men who were members of a small family, but whose parents, either one or both, were members of a large family (over five). I made the following notes:

P. F. T., aged 30. Only child of parents. Had two supernumerary nipples—one on either side.

A. H. M., aged 35. Had two brothers and one sister. Supernumerary nipple below left breast.

C. D., aged 39. Had one brother and one sister. Married nine years, no children. Father member of a large family, mother of a very large one. Had supernumerary nipple below left breast.

G. A. J. B., aged 37. One brother only. Father one of seven children, mother one of four. Supernumerary nipple below left breast.

W. H. B., aged 37. Had three brothers and four sisters. Both parents members of large families. Supernumerary nipple below left breast.

E. W. H., aged 32. Had three brothers. Father member of family of ten. Supernumerary nipple below left breast.

I was unable to ascertain whether there were any supernumerary nipples in parents. Most of my patients were unaware of the true nature of the occurrence, and thought they were moles. In every case they were quite rudimentary, but a typical small nipple was present, with a surrounding areola varying in size from a quarter to three-quarters of an inch in diameter.

I have evolved a theory in these cases which may be of interest. The grandparents had large families; this was borne out in all the cases which I investigated; in the first two cases I did not inquire. The parents had small families; this was apparent in five out of the six cases. The exception was in No. 5, in which case both parents were members of large families. It would seem as if Nature were making a special effort, in the third generation, to make up for the delinquencies of the second generation in the matter of procreation—by giving an accessory nipple to the male!

CEMENT AND CO.

DR. WALTER G. WALFORD (London, N.W.) writes: There is one thing that has occurred to me as regards the death of Mabel Weightman, recently found lying on some sacks of fresh cement in an unfinished house at Bushey, and where no apparent cause was discoverable. Many years ago a sack of fresh Portland cement was placed in a small outhouse in my premises. Next day I found a large healthy-looking cat coiled up, apparently asleep, on the top of the sack, but in reality dead. It at once occurred to me that as fatal results often follow, when people sleep in lime kilns, from the emanation of carbonic dioxide, that recent cement, which is largely a compound of lime, might give off small quantities of the same gas, and have asphyxiated the cat in its sleep. Now possibly the young girl may have gone into the probably unventilated room where the six sacks of cement were to wait for someone. If my supposition is correct, the CO₂ would make her drowsy. What, then, would be more natural than that she should lie down on the sacks and, finding her breathing difficult, loosen her corset? And this was how she was found. It would be interesting to know if cement does exhale CO₂, and if similar accidents have been noticed.

MEDICAL EXAMINATION OF RECRUITS.

DR. G. F. P. GIBBONS, O.B.E. (Desborough) writes: Now that the Government is making a special effort to secure recruits for the Territorial Army the question of remuneration for the examination of such men will be of importance to many practitioners. I was asked to deal with any possible recruits in my area and was offered the enticing fee of 2s. per man! The forms to be filled up in duplicate can quite successfully vie with these required for a life assurance proposal. Could not the Association take up this matter with the War Office with a view to fixing a reasonable fee for such examinations?

CHILD BIRTH AND LACTATION.

DR. JUSTIN OLDFIELD writes from Darlington, Jamaica: In this age, when women are so apt to wish to avoid "the pains and perils of childbirth," it is pleasant to record that here in Jamaica the advent of a baby is not preluded by anxiety nor accompanied by difficulties. The negro woman is strongly and stoutly built, her limbs are rounded, shapely, and symmetrical, her spine is straight, and her carriage erect. Negro women regularly walk distances of ten to thirty miles, carrying loads on their heads of from twenty to sixty pounds. Their total clothing is a loose cotton dress and a pair of cotton drawers, with a handkerchief round the head. Their diet is chiefly yams, sweet potato, sugar cane, banana, orange, bread-fruit, beans, and rice. It is important to note that on this dietary the nursing mother has always an ample supply of milk, and that artificial feeding of babies is almost unknown.

A MODERNIZED DRUG LIST.

MESSERS. ALLEN AND HANBRY have issued to the medical profession a well-produced little book entitled *Medicamenta Accurata* containing an alphabetical list of the articles manufactured by the firm, with particulars of their composition and dosage. An improvement from the point of view of utility might be to increase the number of cross-references, as the busy practitioner is apt to forget the trade-mark names of articles; for instance, we cannot trace the brand of hydrogen peroxide, which we know the firm manufactures, under either "hydrogen" or "peroxide," while suppositories also are hidden away under some other name.

A TALL TALISMAN.

WE have received from an I.M.S. officer a delightful business circular, issued in all seriousness by a native firm in Calcutta, advertising a "Talisman" which they manufacture. We quote from the circular: "By its use (by its use means simply wearing it round the neck, waist, or arms) one will be free from all disease, all will be blessed with success in every thing and in every act. It prevents untimely death and early decrepitude. A man is sure to get rich within the shortest possible time whether he is engaged in service, commerce, trade, arts, etc., if he prefers to wear one of the wonderful Talismans. It is sure to make him happy and blessed by surrounding him with a merry group of healthy children and beautiful and faithful wife." The testimonials printed are even more ingenuous than this exordium. In every case the full name and address of the writer is given. One gentleman writes: "Allow me to tender my heart-felt thanks for the good that your Talisman has done to me. I passed this year under great difficulties the U.L.I. examination." Another: "After the use of your Talisman my uncle, Mr. — of — Hospital, has received Honours from Government." An official: "On the very next day on wearing your Talisman my pay was increased by 100 rs. The effects are wonderful." Another official: "I cannot find words to express the efficacy of your Talisman. My circumstances in pecuniary matters were really bad, and there has been marked improvement." Health is improved as well as the pocket. One gentleman in an official position writes: "I derived much benefit from your Talisman, which cured insanity of my wife, who was suffering from it for the last 15 years. Send another!" Another official: "Your wonderful Talisman has completely cured my son from all diseases. He looks now in colour like lotus flower and strength like Rheema." This wonder-worker can be obtained at the low figure of one rupee four annas, or, in a gold cover, five rupees.

VACANCIES.

NOTIFICATIONS of offices vacant in universities, medical colleges, and of vacant resident and other appointments at hospitals, will be found at pages 30, 31, 34, 35, 36, and 37 of our advertisement columns, and advertisements as to partnerships, assistantships, and locum tenencies at pages 32, 33, and 34.

THE appointments of certifying factory surgeons at Mauchline (Ayrshire) and Oldham (Lancashire) are vacant.

SCALE OF CHARGES FOR ADVERTISEMENTS IN THE
BRITISH MEDICAL JOURNAL.

	£	s.	d.
Six lines and under	0 9 0
Each additional line	0 1 6
Whole single column (three columns to page)	7 10 0
Half single column	3 15 0
Half page	10 0 0
Whole page	20 0 0

An average line contains six words.

All remittances by Post Office Orders must be made payable to the British Medical Association at the General Post Office, London. No responsibility will be accepted for any such remittance not so safeguarded.

Advertisements should be delivered, addressed to the Manager, 429, Strand, London, not later than the first post on Tuesday morning preceding publication, and, if not paid for at the time, should be accompanied by a reference.

NOTE.—It is against the rules of the Post Office to receive *post restante* letters addressed either in initials or numbers.

THE IMPORTANCE OF THE INFINITELY LITTLE.

BEING THE MACKENZIE DAVIDSON MEMORIAL LECTURE.*

BY

W. D. HALLIBURTON, M.D., F.R.S.,

PROFESSOR OF PHYSIOLOGY IN KING'S COLLEGE, LONDON.

IN 1798 there died in Bologna one who was born and lived there. His name, which has reverberated down the ages, was Aloysius Galvani. Destined for the Church of Rome, but later expelled from that body, he happily turned to science, and became Professor of Anatomy and Physiology at the University of his native city in 1762. The story of his well-known discovery of what was later called galvanism is well known, and does not need recapitulation here. Helmholtz, writing nearly a hundred years later in an appreciation of Galvani's pioneer work, said:

"When Galvani touched the muscles of a frog with different metals and observed their contraction, who could have dreamt that all Europe would be traversed with wires flashing intelligence from Madrid to St. Petersburg with the speed of lightning? In the hand of Galvani, and first even in Volta's, electrical currents were phenomena capable of exciting only the feeblest force, and could not be detected except by the most delicate apparatus. Had they been neglected on the ground that the investigation of them promised no immediate results, we should now be ignorant of the most important and most interesting of the forces of nature."

Had Helmholtz been alive to-day, how greatly might he have expanded this theme; for even he did not foresee the possibilities of electricity and its ramification into every branch of our daily life, including its applications for the detection and alleviation of many of our ills. Animal electricity in its medical aspect is, it is true, as old as galvanism itself. In its early days thinkers imagined the secret of life had been found, and attempts were made to convert dead into living bodies by its means. It soon lent itself to the worst forms of charlatanism and quackery. But as knowledge progressed and ignorance was dispelled, it found its proper sphere, and the importance of the sphere is evidenced by the existence in our Royal Society of Medicine of a Section devoted to electro-therapeutics.

To trace even in outline the various steps which have led to the present proud position in which this branch of science stands to-day would be a task beyond my powers and beyond your powers of endurance, but I may take as my text to illustrate one feature in the advance (if not its mainspring) a reminiscence of my own.

In 1888 I attended at Bath a meeting of the British Association, and as it was almost the first I had been to I listened to the Presidential and other addresses with great attention and with becoming reverence. The President that year was the great engineer, the late Sir Frederick Bramwell, and well do I remember how he started his address. He began by alluding to a speech he had heard from the late Lord Iddesleigh, who charmed an audience for a whole evening by speaking on the very important subject, "Nothing." Sir Frederick said he would not try to copy this feat, but would do his best to speak on "Next to Nothing." By this neat phrase he meant those little things which are of supreme importance. He gave numerous examples from his own subject to show how it was that attention to details had converted crude machinery into effective and useful instruments, whether they were guns or bridges, engines or ships. Among other subjects he took to illustrate his theme I remember he singled out the telephone as a triumph of science which the "next to nothings" had done so much to perfect. At that time he was naturally not aware of how in later years red-tapeism (and the like) would have taken upon itself to neutralize some of the excellent qualities that science had bestowed upon it. At the conclusion he ventured to prophesy that it would not be long before men were able to fly.

But gifted as Sir Frederick Bramwell was with the prophetic instinct, he did not at that time, now thirty-three years ago, foretell the discovery of those vibrations

which it is now customary to term x rays, nor of those other kinds of radiant energy which the name of radium calls up. Still less could he have predicted the value of these discoveries to medicine and to surgery, and least of all would he have pictured even in imagination the coming of a man who so fully illustrated the importance of attention to details, to the "next to nothings," a personality whose name we are met together to commemorate this evening. Sir James Mackenzie Davidson, whose sterling and genial character we all remember with affection, was first and foremost one who never spared trouble; he was one whose numerous inventions, the result of his painstaking attention to apparently small and trivial things, succeeded in making the bare bones of his subject live, just as his skiagrams represented them in life-like perspective.

I wish that your Section could have selected someone more capable than myself of dealing with this subject from the technical point of view. But you could not have chosen one who has a greater admiration for the genius and ability of our lamented friend. Your choice has fallen on a physiologist whose labours have been more directed into chemical than physical channels, and I regard it not so much as a compliment to myself, as an honour to our band of quiet workers who are seeking out the ways of Nature by the way of experiment, and are doing their best to give to the art of medicine the sound basis of scientific knowledge. For too long the workers in the laboratory, and those by the bedside, have been groping out their own salvation in separate ways. Your request that a physiologist should address you to-night is evidence that the *entente* between us which is now happily glowing needs still further strengthening.

I feel, also, that it does us all good to get at times out of our own special ruts. I feel this evening renewed vigour as I come into the fresh air of electro-therapeutics; I can only trust the members of your Section may be able to return the compliment, and find something useful or even instructive in what I have still to say, even although it deals in the main with another corner of medical science than that they are accustomed to live in.

I am not here only to utter sentiments however heartfelt, or platitudes however true, still, before coming to what after all is my main subject, there is one general consideration which I should like to place before you.

The crowded condition of the medical curriculum, in which the poor unfortunate student is presented with an ever-growing number of subjects for study while the length of the day still remains at the usual standard of twenty-four hours, is producing just now one of those attempts which recur periodically to revise his scheme of study. We are told that there is no need for him to learn his anatomy so thoroughly, that his organic chemistry must be reduced to a minimum; and, last and worst, his physiology course must be drastically shortened, and this in spite of the fact that all these subjects are growing fast, and that medical men are seeing more and more the truth that physiology is the corner stone around which the superstructure of medical science is built. Although physiology still figures on paper as quantitatively large, the restriction suggested is in the kind of physiology to be taught, and the term applied physiology designates that what is wanted for the student is physiology in its direct bearing on medical practice. The frog, which has served for so long as the object lesson of so many physiological lessons, is to be deposed from its high position, and, so far as is possible, experiments on man himself are to be substituted.

In speaking of Galvani's work, I have already given one example of how a subject of purely scientific interest, studied with no ulterior or utilitarian motive, was found to be of inestimable value to mankind. Such instances could be multiplied indefinitely. How would Lister's work have been possible without the preliminary academic labours of the chemist Pasteur? When Miescher set out to investigate the chemistry of the roe of the salmon, did he think that it would be on that investigation that our knowledge of the pathology of gonorrhoea would be founded? When Bayliss applied himself to study colloids, he could not have dreamed that a powerful weapon against wound shock would be discovered in that by-path. But I need not weary you with other instances. When a scientific man studies Nature for the sake of pure knowledge, who can say to what practical use his followers may adapt it?

* Delivered before the Section of Electro-Therapeutics of the Royal Society of Medicine.

In deciding in my own mind whether I approve or disapprove of these attempts to reform or revolutionize medical training, I am torn by conflicting emotions. On the one hand, I sympathize deeply with the student, and realize the impossibility of getting a quart into a pint jug; on the other hand, there is my love of pure science, and the conviction that any and every truth must ultimately bear practical fruit. I am not conservative by nature, and welcome every true reform, and I have little sympathy with the legendary professor at one of our ancient seats of learning who, at the end of a life devoted to laborious research, thanked God he had never done anything that would be of the slightest use to anyone. One has in such an impasse to face facts and exercise one's common sense. A thorough grounding in general physiological knowledge must remain a *sine qua non*, but in the details of its many ramifications one must make a judicious selection, and the choice must naturally first fall on those parts of the subject in which the practical outcome is already realized rather than on those the application of which is still to seek. From the point of view of those in this Section, and of those who aspire to join its ranks later, one trusts that the electrical phenomena which are so easily demonstrated in all essentials on the muscles and nerves of frogs will not fall under the ban of those who are trying to limit the excursions of the student into the scientific aspects of the subject.

In speaking further, I thought the occasion might not be inopportune to say a few words on some of the modern problems of physiology, and tell you briefly of some of the progress we have made and are making at the present time. To attack all these questions in the space of a single address would be impossible. Again, one has to make a selection, and I intend to limit myself to three. I think it will be found that in these three cases the importance of the "next to nothing" principle will be abundantly illustrated. This is the day of great things, because we are realizing the importance of the infinitely little.

The invention of the word hormone dates from the discovery made by Bayliss and Starling of the chemical messenger which is elaborated in the intestine under the influence of the gastric acid, and which, after absorption, stimulates the pancreas to pour out its juice at the time when it is wanted to carry on to completion the digestive work begun in the mouth and stomach. Previous to this time we were imbued with the teaching that the harmonizing or, to use Sherrington's phrase, the integration of the bodily functions is due to the activity of that ruling system of the body known as the "nervous system." The nervous system is not displaced from its high estate, but for the first time in the history of our science we realized to the full the valuable help rendered to the telegraphic service of the body by humbler but none the less useful ministers to our comfort which Starling aptly compared to the postmen. Although the actual word hormone was not coined until secretin was discovered by Bayliss and Starling, the importance of chemical agents had been really recognized somewhat earlier, and more especially in relation to that group of formerly mysterious organs known then as the ductless glands, but now generally dubbed the endocrine organs; they are so called because they form an internal secretion, that is a secretion which leaves by no specific duct, but by the blood or lymph that streams from the organ in question. It was no wonder that ignorance prevailed for so long as to their function, seeing that the new chemical principle each forms is masked by the protein-rich fluid which it enters. But now, thanks to the overcoming of this and other difficulties, we know a good deal about the thyroid, the adrenal body, the pituitary gland, the islets of Langerhans, the corpus luteum, and others.

Many details have still to be worked out, and some of our ductless glands are territories almost as unknown as Central Africa was in our youthful days. The chemical messengers are all grouped together under the general name hormone, a term which immediately "caught on." Attempts have been made to distinguish classes among the chemical messengers to indicate that some stimulate, some depress, and so forth. But the terms introduced with this object by Sharpey Schafer, and more recently by Gley, have not yet at any rate passed into general usage. Speaking of our French colleague, Professor E. Gley, reminds me that the term "internal secretion" was

first employed by another great Frenchman, Claude Bernard, in relation to the liver's important work in pouring sugar into the blood stream at a steady pace. In most cases the index pointing the way to discovery has been the result of removing the organ and of injecting extracts of it into the blood and noting the results. Professor Gley has recently in one of his published discourses laid down the conditions which must be fulfilled in order that a gland may be admitted to the class of endocrine organs. He very properly decries trust being placed merely upon the results of ablation or the effects of injecting extracts. In addition there are three main conditions which must be conformed to in order that a gland may be enrolled within this category: first, the anatomical, that is, the absence of a duct; secondly, the chemical, the recognition in the venous blood of such organs of a specific chemical product; and thirdly, the physiological, the possession by the venous blood of specific physiological properties, and this last is of course the superlative test. He takes the work of Bayliss and Starling on secretin as an example; it was not until Fleig, and Enriquez, and Hallion actually worked with the venous blood coming from the duodenum that the probability of the truth of Bayliss and Starling's views founded upon the results of injection of duodenal extracts was rendered a certainty.

Professor Gley has done good service not only by his own experimental work, but in pointing out the way in which work on this subject must be continued. For we must confess that up till now our conclusions in reference to many of the endocrine glands do not rest on experiments which fulfil all of Gley's conditions. We must further recognize that it does not follow that because most of these ductless organs form internal secretions, all of them do so. Nature seldom works in one pattern, but her *modus operandi* varies. The parathyroids, for example, probably form no substance useful to the rest of the body's machinery, but probably act by removing or neutralizing harmful products formed elsewhere. Noël Paton and his colleagues have shown that the poison they detoxicate is a guanidine compound derived from muscular metabolism, and if this is not removed tetany is the result.

Restricting ourselves, however, to the truly endocrine glands, let us dwell for a moment, not on what we know, but on the gaps in our knowledge. The chemical constitution of that iodine complex which is secreted by the thyroid has been unravelled by Kendall in America. The constitution of adrenaline secreted by the suprarenal medulla is so well recognized that it has even been synthesized by laboratory processes. The composition of pituitrin secreted by the posterior lobe of the pituitary body looks as though it will be the next to yield to the chemist's manipulations. But what do we know of the internal secretion of the part of the pituitary which is probably most essential to life, or of that of the suprarenal cortex, which is certainly the most important portion of that gland, or the nature of the internal secretion of the pancreatic islets, or of the corpus luteum in the ovary, and even of secretin itself? I mention these few hiatuses in our knowledge to illustrate how much our wisdom is in its infancy, what fields are still to be tilled, and lest we swell with undue pride at our present accomplishments. But, whatever gland we think about, we may be sure that quite minute quantities of their various secretions are sufficient to do the necessary work, and that these infinitesimally small amounts are indispensable, not only for our well-being, but for life itself. This, at any rate, has been proven for those secretions which can be quantitatively examined. Even although our knowledge of pituitrin is still over the border, we know that extreme dilutions of pituitary extract can exert marked power in causing plain muscle to contract vigorously, and, in the case of adrenaline, one can demonstrate that the injection of a few cubic centimetres of a solution containing only one part in a million or more of neutral saline diluent will provoke marked physiological effects on heart and blood vessels.

Other examples of organic substances which call forth physiological effects in equally minute or even more attenuated concentrations might be given; there is, for instance, an acetyl derivative of choline, one of the constituents of our body, and the powerful amine known as histamine, which may be mentioned. In anaphylaxis, also, similar infinitesimal amounts of organic substances produce gigantic effects. Such minute doses make the doses of that product of a past generation known as

homeopathists seem enormous in proportion; a reflection which will awake an echo in the hearts of those who deal with radium emanations.

From the days when we learnt physics, we doubtless remember that important natural law which states that action and reaction are equal and opposite. The law holds in the opposing activities of our hormones, and an important branch of study has been to ascertain how such opposing actions are balanced so that they work together for good. The way in which the different organs, endocrine and otherwise, act and react upon each other has been one of the most instructive and interesting outcomes of the discovery of the internal secretions themselves. I do not think one could find any other subject which has in the present day so deeply influenced medicine as the hormone conception. Instead of remaining, as many physiological discoveries have remained, dormant as praiseworthy laboratory curiosities, the application to the practical study of disease has here been immediate, and medicine, surgery, gynaecology, and the numerous specialities of practice have all been profoundly influenced by the new doctrines. Among the specialities one must here particularly allude to the one represented here this evening. Those who, on the one hand, are employing in diagnosis and treatment various electrical forms of energy, and those who are similarly engaged in radiology, have recognized that they have the power of controlling and influencing the endocrine organs to form more or less of these internal secretions for the benefit of their patients. I wish I had the special knowledge to dwell for a moment on this aspect of the problem, but those who are listening to me will be able to fill in the details of this part of the picture. The discovery of radium has been one of the greatest feats of modern science, but I need not tell my hearers that this new power for good may, like the α rays, be also in unwise hands an equally powerful agent for evil. When the activity of its emanations on living cells were first demonstrated there was perhaps naturally too great confidence displayed in its ability to cure every ill, including those which, like cancer, had defied every previous effort to conquer them. That phase is now passed, and the proper place of radium in our armoury is being adjusted to the facts. History is always repeating itself, and the story of radium is a repetition of what has occurred before when startling new discoveries had been revealed to the world. In the old days of the alchemists, who sought by magic and by the help of astral and similar agencies to discover the philosopher's stone and the elixir of life, the disappointments and failures were as numerous as the attempts to discover the secret of vitality. When alchemy was replaced by more exact science, new revelations were wistfully and hopefully regarded as likely to yield the long-hidden secret; two of these epochs I have already alluded to to-night—one was the discovery of galvanism in the eighteenth century, the other of radium in the twentieth.

May I digress and linger a moment to mention one more which marked a similar epoch in the seventeenth century? I allude to the discovery of phosphorus. In the early years of that century a substance was prepared by heating heavy spar with combustible organic matter (egg white and charcoal) and this substance glowed in the dark, and for many years the name phosphorus, or light-bearer, was given to any substance which had the same property. The actual element we now call phosphorus was prepared by Brand about 1670, and was at first made in small quantities only from animal products—namely, urine and bones. Can it be wondered at, that in those days of superstition and mysticism the discovery in animal products of a substance which burnt and emitted light without ignition was hailed as a discovery which at last had hit upon the vital principle? Phosphorus played an important part in the development of the theory of phlogiston which soon afterwards dominated philosophic thought, but in time died like so many other theories before and since. The *furor* created by the discovery of phosphorus had been paralleled by the discovery of radium in recent years. Only let us congratulate ourselves that the 250 years which intervened between the two events have taught us more wisdom and we are not so likely to repeat the hysterical enthusiasm of our ancestors.

This, however, is a parenthesis which originated from my mention of the fact that hormones and all that they connote are not simply of chemical interest, but that their importance is recognized as a factor in electro-therapeutics as in other branches of medical science. I do not think I can say the same thing about the second subject I have selected to bring before you. My only excuse for so doing is that it is one on which I can venture to speak at first hand. It may not interest you as electro-therapists, though it is not devoid of importance to you as human beings, for to all living creatures the question of food is of superlative value. The particular portion of this wide problem I intend to say a few words about is one in which also the quantitatively little is qualitatively great. I allude to those substances in our diet which we term the vitamins. The word "vitamin" is not as old as the present century, and although it is not an ideal term it has come to stay, and is certainly less cumbersome than the phrase "accessory food factor" which is its synonym.

The lecturer then gave a brief summary of our knowledge of the vitamins, and alluded to the importance of the "next to nothing" principle there. Though accurate quantitative methods are still to be devised for their estimation, one thing is perfectly certain, and that is that the requisite amount is extremely minute, and this small amount is capable of converting a useless into a useful diet. He then continued:

Before I leave the subject of food may I unburden myself of a suggestion? Empiricism is not always to be condemned. What we call empiricism is frequently the result of past experience. As an example, take a prescription of cod-liver oil, or of butter and cream. A few years ago it would have been impossible to explain why these forms of fat are superior, we will say, to olive oil and vegetable margarine. The mere fact that they are better was empirical, and now the practitioner has been fully justified, and research at last has told us the explanation—namely, the existence in the fats, which are the more valuable for remedying malnutrition, of a health-giving vitamin.

May not this in the future be repeated? If you have high blood pressure why does your medical man tell you you may take fish and poultry and eggs, but that you must abstain from beef and mutton? I can picture a sceptical and argumentative physiologist saying, "Why? The materials you mention and I am advised to take or refrain from taking are all in the main composed of protein, and surely it is not physiological to give me such futile advice." My answer to this would be, "True, it is not explicable yet on physiological grounds. It is the mere result of empirical experience. But wait a few years, and it is quite on the cards that by that time science may have stepped in and explained the puzzle, just as a few years ago it was able to explain why cod-liver oil is better than olive oil." There is probably in the harmful meats some hitherto unrecognized principle, unrecognized because it is present in minute quantities; or it may be the absence of an indispensable material. It is one of the "next to nothings," but it makes all the difference. "There is one kind of flesh of men, another flesh of beasts, another of fishes, and another of birds." I wonder if St. Paul ever imagined these pregnant words contained more than what he intended to convey by them.

The third topic the lecturer selected to illustrate the importance of attention to apparently insignificant minutiae was that of the capillary circulation, a subject which rose into importance during the war in relation to "shock." Here, again, especially in some forms of secondary shock where actual haemorrhage may have been insignificant, but where crushed tissues were the usual accompaniment, it seems inevitable to accept the views urged by Dale and others, that it is a toxicæmic condition. The poison is produced from tissue breakdown, and operates by reducing capillary tone, so that the blood is stagnant and side-tracked in the capillary lake. Whether histamine, which certainly produces a shock like state in this way, is the actual poison in secondary traumatic shock, or the only poison, is a question still to be answered. But, whatever the poison is, it is one of which a very small quantity produces a very large result.

The lecturer concluded as follows: In conclusion, I must thank you for the patience you have exhibited in listening to me for so long. I wish I could have chosen a subject, or subjects, more akin to your own speciality. But if anything I have said in my disjointed remarks will help you to realize how widespread is the importance of the infinitely little my task will not have been in vain.

GLANDULAR FEVER.

BY

H. LETHEBY TIDY, M.D. OXON., F.R.C.P. LOND.,

ASSISTANT PHYSICIAN TO ST. THOMAS'S HOSPITAL AND PHYSICIAN
TO THE GREAT NORTHERN HOSPITAL,

AND

E. B. MORLEY, M.B., B.S. LOND.

GLANDULAR FEVER was first described by E. Pfeiffer in 1889 under the title "Drüsenfieber." It may be defined as an acute infectious disease principally of children, characterized by rapid enlargement of the cervical glands and by a less constant enlargement of the liver, spleen, axillary, inguinal and other glands. The disease is rare, but there is some reason to believe that a considerable number of cases are occurring at the present time.

The largest epidemics are those recorded by Park West, 96 cases; Botschkowsky, 54 cases; Byers, 33 cases; Stark, 30 cases; Tschajagjew, 24 cases. Korsakoff has reported 29 cases observed over a course of years.

Pfeiffer stated in his original article that the disease occurred in small epidemics, and especially in "house epidemics"; when one child of a family was affected the others rarely escaped. Subsequent observers have agreed that it is infectious. Fisher records 8 cases in one family, and Chapman 5 in his own household. Park West observed an epidemic in a country district in Ohio, and saw 96 cases in the course of three years, besides hearing accounts of at least 40 others. The 96 cases occurred in forty-three families, about 20 children in the affected families not being attacked. He states that the epidemic spread irregularly, the houses attacked not being in any special contiguity or social connexion with each other. Von Starck's 12 cases occurred in eleven families, Haas's 12 cases in ten families, and Schiller's 11 in nine families. Schäffer's 21 cases occurred in the space of four months in an institution for children, but there is no statement as to the total number of inmates. Numerous sporadic cases are also on record. Authorities agree that it is more common in the spring months.

CLINICAL FEATURES.

The incubation period has been noted by many observers and may be stated to be 5 to 10 days, most commonly 7 or 8 days. The extreme limit may be longer.

The disease is principally one of childhood. Botschkowsky had the experience, apparently unique, of observing an epidemic of 54 cases in a battalion of soldiers. Apart from this, it is probably correct to say that at least 80 per cent. of recorded cases were under the age of 12 years, and the majority between the ages of 5 and 9 years. Park West's youngest patient was 7 months and the eldest 13 years. He had no case in an adult. Robertson has reported a case in an infant of 6 months. The youngest of Schäffer's cases was 4 months old and the eldest 16 years.

Adults, however, are certainly not immune. In the series of 464 cases there are 20 adults (excluding Botschkowsky's epidemic), the majority being young mothers of affected children; three patients were over 40 years of age. In adults the condition tends to be very mild and malaise slight, though Korsakoff saw a severe case with nephritis. There is no record of its occurrence during the war. The condition is, however, easily overlooked and may be mistaken for aberrant mumps, though one of us (H. L. T.) spent eighteen months in a hospital for infectious diseases in France without recognizing its entity or calling to mind its existence.

The onset is sudden, with the usual symptoms of an acute pyrexial attack in children: restlessness, loss of appetite, constipation, furred tongue, rapid pulse, and occasionally vomiting. Abdominal pain is sometimes present, and may be severe.

Enlargement of the Lymphatic Glands.

This may be present with the earliest symptoms or develop rapidly within twelve to forty-eight hours. The glands constantly affected are the cervical glands, deep to the sterno-mastoid muscle about the middle of its length. The enlargement is marked, and produces a definite swelling of the neck. On palpation several discrete glands are felt, often the size of walnuts. Robertson records glands as

large as a hen's egg in an infant of 7 months, and states that they were painless. The skin is not reddened, and the tissues are not oedematous.

The cervical enlargement is commonly unilateral at the onset. The glands on the opposite side frequently, but by no means invariably, enlarge later, usually within two to four days of the onset, but occasionally not until the first side has subsided to a varying degree. In Schäffer's series of 21 cases the cervical enlargement was unilateral throughout in 11, bilateral from the onset in 3, and affected first one side and then the other in the remaining 7. Some authors state that the left side is much more commonly affected than the right, but there is no definite agreement on this point. Other glands in the neck may enlarge subsequently, but to a much less extent. The initial enlargement is below the level of the angle of the jaw, and the position and general condition of the swelling differs from that of glands secondary to infectious of the tonsils, teeth and nasopharynx.

The parotid and submaxillary glands are not affected. The submaxillary glands were enlarged in one case of Schäffer's and in one of Trautmann's, but not in others of their series. The parotid was enlarged in one case of Hirschmann's, but it is doubtful if this group was really glandular fever. Enlargement of the parotid, submaxillary, epitrochlear and many other glands is referred to by Haas, but without quoting instances. By no other writers are they stated to be enlarged; nearly all have specifically mentioned their absence, and it may be accepted that the parotid and submaxillary salivary glands are not affected. The submaxillary lymphatic glands and possibly the pre-auricular gland may, however, be enlarged.

Enlargement of the axillary and inguinal glands has been noticed by most observers. Park West states that they were palpable in 75 per cent. of his cases, and enlargement has been recorded by Trautmann, Bellotti, Korsakoff, Haas and many others. Pfeiffer, in 1889, said that they were not affected, but Von Starck had noticed them in his series of 12 cases in 1890. Schiller did not find them in his 11 cases, and a few recorders of individual cases noted their absence. It may, however, be accepted that they are palpable in the majority of cases, but never attain the size of the deep cervical glands.

Pain and tenderness of the cervical glands may be entirely absent; there is usually some pain on movement of the head, but palpation of the glands even in the acute stages may be painless. Some pain and difficulty in swallowing may be complained of, and is referred not to the fauces, but under the level of the isthmus of the thyroid.

Enlargement of the mesenteric glands has been much discussed, and involved with this is the occurrence of abdominal pain. Pfeiffer noted pain in the abdomen as one of the characteristics, and stated that it was localized exactly in the mid-line below the umbilicus. Others have not supported this exact localization, and it may evidently be more generalized, but its presence has been repeatedly recorded. Byers does not mention its presence or absence in his group of 33 cases, but with this exception it is referred to by all others who have observed many cases. Park West states that some degree of abdominal pain or tenderness occurred in about 75 per cent. of his 96 cases. The pain may be very severe, as in specific cases published by Dawson Williams, Rudolf, and others.

The mesenteric glands may be definitely palpable. Many writers have not referred to them, but Korsakoff, Haas, Bellotti, and others record their presence. Jones states that they are palpable in 40 per cent. of cases. Park West said that he felt them in 37 of his 96 cases, and believed that the number would be larger if he had examined the earlier patients more carefully.

There is some evidence that the *peribronchial glands* may be affected. Von Starck in 1890 recorded the occurrence of a paroxysmal cough resembling whooping-cough, but without the wheep, and suggested that this was due to the pressure of enlarged peribronchial glands. Similar paroxysmal coughs have been noted by several French writers (Moussous, Comby, and Labbé); on the other hand, nearly all the writers state that no cough occurred and that no abnormal signs were present in the lungs. It may be accepted that the lungs are unaffected.

The only recorded autopsy is Korsakoff's. There was definite enlargement of the axillary, inguinal, peribronchial and mesenteric glands, but in this case the cervical glands had suppurated.

OTHER SIGNS AND SYMPTOMS.

The condition of the tonsils and pharynx has been closely observed. Pfeiffer's attention appears to have been attracted to glandular fever owing to the disproportion between the size of the glands and the changes in the fauces. A slight reddening of the pharynx, he says, is the most that is present, and frequently there is no obvious change. Subsequent writers have fully confirmed his observation; thus Park West, Byers, Stark, Korsakoff and Schäffer record absence of tonsillitis in any of their cases, which make a total of 209. Stark's 30 cases occurred amongst children of the London area in whom diseased conditions of the tonsils and pharynx notoriously are very common. Park West states that in his series there were 29 cases with some reddening of the pharynx, and 4 had definite pharyngitis. It may be accepted that usually there is no obvious abnormality of the fauces, but that occasionally there is slight reddening of the pharynx, which bears no relation to the size of the glands.

No rash accompanies the condition; Heubner, who spoke at the same meeting as Pfeiffer in 1889, stated that in some similar cases he had seen urticaria was present. Korsakoff, in 1905, says that herpes labialis occurred often in his series, but the only other recorded case is one of Schäffer. Erythema multiforme is recorded in two cases by Tschaikowski; scarlatiniform eruptions occurred in one case of Botschkowski, and in one case of Horschelmann. Thornton published a case of glandular fever associated with erythema nodosum; this patient was a child of 5½ years, in whom a mitral systolic murmur was present on first coming under observation, and it is impossible to exclude the occurrence of rheumatic fever. There is no record of any other rashes, and these exceptions are obviously negligible in a series of 464 cases, mainly in children.

It may be accepted that there is no eruption associated with glandular fever.

Epistaxis may occur at the onset, which is not surprising if we are to regard glandular fever as an acute specific infection. It is, however, rare. The first instance was recorded by Chapin in 1897, among 5 cases in his own family, epistaxis occurring in 4. It also occurred in 2 cases of Trautmann's, in two of Schäffer's, and in 1 of Rudolf's. It is mentioned by Tschaijaw and Comby. There is no record of other cases. When it takes place it is apparently profuse.

Vomiting occurs occasionally at the onset.

The pulse may be rapid, while the temperature is high, but cardiac complications do not occur.

Constipation was mentioned by Pfeiffer as being severe. It may terminate with diarrhoea or with the discharge of slimy motions at the end of the first week. The early writers refer to this sequence as almost a characteristic symptom of glandular fever, and considered that convalescence commenced with the discharge of mucus. Constipation, while evidently common, is by no means invariable, and it is doubtful whether much stress should be laid on it.

The liver and spleen are enlarged in a considerable proportion of cases. Pfeiffer noticed that in the severer cases both were palpable, and the majority of subsequent writers have confirmed this. Park West noted that the spleen became palpable in 57 of his 96 cases, and that the liver was enlarged in 87. Korsakoff did not note any definite relation between the enlargement of the spleen and the severity and duration of the illness. There is some disagreement as to the frequency with which the spleen is palpable. Byers, recording 33 cases, does not mention the liver or spleen, and possibly may have overlooked them. Stark mentioned the spleen only once in 30 cases, nephritis being present in this instance. Schäffer states that the liver and spleen were not palpable in any one of his 21 cases. On the other hand, Jones, who refers to 20 cases, states that the spleen was palpable in 80 per cent. and the liver in 90 per cent., and Schiller felt the liver and spleen in each of his 11 cases. Such differences may be partly due to variations in different epidemics and series of cases. Probably it is partly due to individual observers, since it is well known that the recognition of the tip of the spleen is frequently a matter of difficulty and doubt.

From a general study of the literature it appears undeniable that the spleen is palpable in a considerable number of cases, which may be placed at about 50 per

cent. Pfeiffer states that it usually becomes palpable at about the fourth day, but there are no other observations for checking this opinion. In our case it was just felt on the third day and easily palpable on the fourth.

The temperature usually rises to 101° to 103°, occasionally it may be as high as 104°. It corresponds roughly with the size and duration of the marked glandular enlargement, usually being maximum on the third or fourth day, then falling rapidly and becoming normal early in the second week. When the onset is unilateral the temperature may fall as this side subsides, and then rise again as the opposite side enlarges or if it recurs on the same side. Schäffer noticed such relapses in 10 cases. In mild forms there may be no rise of temperature, as noted by Schäffer and others. In Botschkowsky's 54 cases in adults 10 were apyrexial. The fall may be so rapid as to suggest a crisis, as in some cases of Park West and Von Starck, but usually it is more gradual.

Bacteriological investigations have been principally directed to cultures from the fauces, and, as may be expected, they resulted in the growth of streptococci, staphylococci and pneumococci, with influenza bacilli in a certain number of cases. The earlier observers dealt very fully with these investigations, but little importance will now be attached to them.

Cultures from the glands themselves have been made only in a few cases in which suppuration occurred, and in these streptococci have always been present. In Korsakoff's fatal case streptococci were found in the heart blood and other sites in cultures taken twelve hours after death. The glands had suppurred and the child died with the symptoms of septicaemia. Tschaikowski claimed that in 3 cases he isolated influenza bacilli from the blood during life. As Schäffer points out, these results must be accepted with caution, as it is stated that the bacilli were isolated on a simple agar medium without blood, and subsequent subcultures were grown on the same medium. Schiller found influenza bacilli, together with streptococci and staphylococci, in the pus from a gland. Loude and Froin in one case isolated pneumococci from the blood. The patient's father had had lobar pneumonia three weeks previously, and they suggest that this was a direct infection.

A general review of the bacteriological investigations reveals nothing specific.

There are very few records of examination of the blood, and these are either scanty or made in cases in which suppuration of the glands had occurred. Jones gives the following results in two cases:

Case 1.—On sixth day, leucocytes 14,900 per c.mm.; on ninth day, leucocytes 8,900 per c.mm.; red cells 4,000,000 per c.m.m.; haemoglobin 90 per cent.

Case 2.—On eighth day, leucocytes 7,000 per c.m.m.

In one of Rudolf's cases the glands subsided but enlarged again a month later and suppurred. When it was suspected that pus was forming frequent blood counts were carried out, but "showed no leucocytosis."

Just before the operation the blood count was: Leucocytes, 7,000 per c.m.m.; red cells, 4,500,000; haemoglobin, 80 per cent.; polynuclear neutrophils, 60 per cent.; no abnormal cells. After the operation the number of leucocytes was "about doubled" for a few days.

These are the only instances in which definite blood counts are referred to, and no other details are given. Many observers mention the subsequent development of anaemia and its obstinate character.

Complications are rare. Nephritis is the most important. It was mentioned by Heubner in remarks made at the meeting at which Pfeiffer read his original article, and has been referred to by many subsequent writers. When it occurs it is frequently, usually in severe cases, stated to be a "haemorrhagic nephritis." The onset is at the commencement of the illness or within a few days. There is no record of the occurrence of oedema. All writers agree in stating that nephritis never becomes chronic, but the evidence is scanty and cannot be regarded as conclusive. The summary of the statistics given in articles in which both the total number of cases and the number of cases of nephritis is given shows 17 instances of nephritis in a total of 270 cases—an incidence of 6 per cent. There is no record of the occurrence of purpura or of any other form of haemorrhage except the initial epistaxis.

Suppuration of the glands is a very rare occurrence, indeed the earlier writers deny that it ever took place. Only 9 instances are recorded in the literature. One of these, Korsakoff's, was fatal. In all cases in which bacteriological investigations were made streptococci were present; staphylococci or other organisms are also mentioned occasionally. In Rudolf's case the glands subsided, but enlarged again one month later and then suppurated. In all recorded cases the suppuration was confined to the cervical glands.

Otitis media is recorded in 4 cases—in 2 of Schäffer's and in 2 of Durno's. In one of Schäffer's cases the glands had suppurated. There is no mention of otitis media elsewhere in the literature.

Pulmonary complications are confined to the observations of a paroxysmal cough referred to above. Coryza is mentioned by one or two writers, but most observers definitely refer to the absence of any catarrh. There is no record of the occurrence of orchitis, and the diagnosis of pancreatitis has never been made.

PROGNOSIS.

The prognosis is favourable. The enlargement of the glands usually reaches its maximum about the third or fourth day, and after a further two or three days the glands rapidly diminish in size. At the end of one to two weeks there is no visible swelling, the temperature is normal, and definite symptoms of malaise have passed away. Recurrences are not infrequent, and, as has been mentioned above, there may be either an enlargement of the glands on the opposite side to that originally affected or a return of swelling on the same side. Such recurrences are accompanied by pyrexia and prolong the acute stage.

The slowness of convalescence has attracted the notice of many observers. The glands, though no longer visible, often remain palpable for many weeks or even months. Anaemia is frequently referred to as developing during convalescence and persisting for a considerable time. The general health is poor during this period. Complete recovery finally takes place. No second attacks have been recorded.

Only four fatal cases are recorded in the literature. In Park West's fatal case the child had been previously in poor health. Bellotti had two fatal cases in children, aged 1½ and 3 years; both began with the ordinary symptoms and the glands subsided, but cachexia developed and was finally fatal. In Korsakoff's case the cervical glands suppurated.

This is the only instance in which an autopsy is recorded, and, unfortunately, findings are complicated by the probability that death was due to septicaemia. The cervical, peribronchial and mesenteric glands were greatly enlarged, and the axillary and inguinal glands slightly. Microscopic sections of the glands were said to show hyperplasia of the parenchyma, with signs of inflammation. There was no evidence of tuberculosis or lymphadenoma; ecchymoses were present on the pleura; in the left pleural cavity was 8 oz. of fluid. The spleen was enlarged. The kidneys were in a condition of glomerulonephritis. Streptococci were present in the pus of the cervical glands before death, and twelve hours after death were isolated from the axillary glands, liver, spleen, kidneys, bone marrow, and heart blood.

The following is the account of a case which has been under our observation:

C. G., male, aged 8 years. First seen on July 1st, 1920. Previous health very good. Measles in April, 1920. Had been somewhat irritable for three or four days previously. The parents noticed swellings in the neck on June 30th, and on July 1st the father noticed that the glands were enlarged "all over the body." Slight nausea on previous day, but no vomiting. The general condition was good. He had a good colour and no evidence of anaemia. There was no sore throat. On examination: The lymphatic glands in the neck were markedly enlarged. Deep to the sterno-mastoid and about the middle of its length on both sides were several glands about the size of walnuts, causing a definite prominence in the neck, especially on the right. There was no superficial oedema, and the glands on palpation were discrete, suggestive of the condition found in Hodgkin's disease. Palpation was almost painless. On the right side the superficial submaxillary

lymphatic gland was greatly enlarged and bulged away from the jaw. It could be distinguished from the deeper lying salivary gland. The other glands in the neck were also enlarged, but to a much less degree. The axillary glands were enlarged on both sides. In the groin there were two large glands on the right side and smaller ones on the left. In the abdomen two large mesenteric glands were easily palpable just to the right of the umbilicus and slightly below it, and they were somewhat tender. It was thought that the tip of the spleen could be felt. There was no purpura or haemorrhages. The tongue was slightly furred. The fauces showed no abnormality and the mouth was quite clean. The heart and lungs were normal. The urine contained no albumin or sugar, and remained normal throughout. There were no septic foci in the scalp, ears, or elsewhere except one curious molar on the left side, which was painless. The temperature was 103°. On July 3rd the temperature was 103°, but the general condition remained good, and the boy was hungry and wished to be allowed to get up. All the glands were larger and the spleen was now definitely palpable. On July 4th the temperature fell rapidly, almost suggesting a crisis. The glands in the neck were distinctly smaller, but the spleen was now nearly two finger-breaths below the costal margin. The other glands were unchanged. The bowels were opened freely on this day, constipation having been present previously. On July 5th the glands in the neck were again smaller and continued to diminish rapidly from this date. The remaining glands, however, diminished more slowly. By July 11th the patient felt perfectly well and was allowed up. The glands were still diminishing and the spleen was only just palpable. On July 18th the spleen was no longer felt. The glands in the groin appeared slightly larger and the other glands about the same as a week previously. The child appeared somewhat paler than before, and the mother said that he was easily tired.

Subsequently progress was uninterrupted, but the glands, even at the present time, remain palpable. The blood counts are recorded in tabular form. The percentage of lymphocytes is very striking. It rose to a maximum on July 5th and then probably commenced to diminish, at first rapidly and then more slowly, and it is now approaching normal. The large and small lymphocytes are classified together, but throughout large lymphocytes predominated, and on July 5th formed

72 per cent. of the total white cells. There were no abnormal leucocytes and no abnormal erythrocytes. Apparently there was a slight but persistent anaemia. The Wassermann reaction was negative.

Other children in the family were not affected, but the patient was isolated early in the attack.

It is probable that a patient under the care of one of us at the Great Northern Hospital was also an example of glandular fever.

Examination of Blood.

Date.	Erythrocytes.	Haemoglobin.	Leucocytes.	Polynuclear Neutrophils.	Eosinophile.	Lymphocytes.	Large Hyaline.	Small Cells.
		%		%	%	%	%	%
1920.								
July 1	...	—	15,000	23.0	1.0	74.5	1.0	0.5
July 3	...	4,800,000	90	14,400	19.0	0.8	77.4	2.4
July 5	...	4,850,000	—	—	12.2	0.8	84.6	2.0
July 11	...	4,850,000	—	9,000	24.6	1.4	71.0	2.2
July 18	...	5,200,000	—	7,800	36.0	1.0	58.0	4.5
July 25	...	4,800,000	90	8,100	35.5	1.5	59.5	2.5
Aug. 1	...	4,750,000	90	10,000	40.0	2.5	55.0	2.5
Sept. 15	...	5,100,000	100	—	43.4	1.6	50.4	4.2
1921.								
Jan. 8	...	5,300,000	100	15,000	57.8	1.4	38.2	2.0

Other children in the family were not affected, but the patient was isolated early in the attack.

It is probable that a patient under the care of one of us at the Great Northern Hospital was also an example of glandular fever.

This was a boy, aged 7 years, admitted on December 8th, 1920. Malaise had commenced twelve days previously, and after two days the glands in the neck were noticed to be enlarged. They subsided rapidly, and after a few days in bed he was allowed to get up, when it was noticed that the urine was "blood red," and also that the face was swollen. The red urine lasted about a week. On admission he looked pale and the glands in the neck were palpable. The fauces were clear. There were a few small glands in the axillae and groin. The

urine contained albumin and casts. The blood count on December 16th was as follows:

Leucocytes	15,500 per c.mm.
Polynuclear neutrophils	60 per cent.
Lymphocytes	35 "
Eosinophils	2 "
Large hyalines	5 "

A trace of albumin was still present on discharge on December 31st. There were six other children in the family, none of whom were affected.

A third case has also been under observation at St. Thomas's Hospital, but the glands had almost subsided when the patient was first seen. The blood and urine were normal. Another child in the family had been similarly attacked about a week previously.

ETIOLOGY AND PATHOLOGY.

The nosology of the disease presents several questions. Is it an acute infectious disease? If so, is it a specific disease or an aberrant form of some common fever?

The evidence that it is infectious is sufficient to be accepted as proof. Pfeiffer stated that it occurred in small, limited epidemics and in house epidemics, and while numerous sporadic cases have been recorded, there is sufficient evidence that his statements are correct. Fisher, in 1897, noted 8 cases and Chapman 5 cases in one family, and numerous instances are recorded in which several members of a household have been attacked. It has been observed frequently when this occurs that the interval between successive cases is about seven days, all the members not being attacked simultaneously. For example, this was the interval between the two cases in Rudolf's family, and Park West states that when two children of a family are affected, the second case most commonly commenced on the seventh day after the first.

Examples of more widespread epidemics have been given above, the largest being Park West's 96 cases in forty-three families widely scattered over a large area. Park West noticed that the infection spread irregularly.

The view that it is an acute infectious fever is consistent with the general course of the illness, with the occasional occurrence of epistaxis, with the occurrence of nephritis, and with the observation that treatment has no effect on the course of the acute stage.

Admitting that glandular fever is infectious, the question arises whether it is a specific disease or a variant of some common fever. The similarity to mumps is superficial rather than real. Evidence has been given above that the parotid and submaxillary salivary glands are not affected in glandular fever, and there is no recorded instance of orchitis. In mumps the swelling frequently commences behind the jaw just below the ear, but it is characteristic of glandular fever that the site of the enlarged glands is definitely lower than this—that is, about the middle of the length of the sterno-mastoid muscle. A decisive argument for the distinction of the two diseases is the number of instances in which children with glandular fever have previously or subsequently had an attack of mumps. This occurred in 54 of Park West's cases, and Byers also notes that several of his 33 cases had previously had mumps. With regard to exanthemata, rashes do not occur in glandular fever, and even in the larger epidemics no intermediate cases have been recorded.

The mode of spread in epidemics is sufficient to eliminate syphilis, although in the diagnosis of a sporadic case it might have to be considered. There is no record of any Wassermann reaction. The general type of the glandular affection is unlike syphilis, which does not tend to produce a very marked enlargement of the cervical glands. Again, the mode of spread is unlike tuberculosis. In Korsakoff's fatal case the glands examined showed no signs of tubercle. There is no other record of a microscopic examination of a gland.

Many of the earlier writers considered that glandular fever was a form of influenza. At the present time no one knows what influenza is, but it is noteworthy that the last article on glandular fever in the literature was published in 1914, and it is consequently justifiable to assume that it is not influenza as we have known it in recent years.

With regard to infection from the fauces—another suggested cause—it has been pointed out above how very little change is recognizable at this site. Tonsillitis is practically unknown. Pharyngitis is very uncommon and rarely exceeds slight reddening, yet several authorities have upheld the theory of pharyngeal infection. Trautmann argues on anatomical grounds that the glands

affected are those supplied by lymphatics from the pharyngeal tonsil. Most of these writers have ascribed the infection to streptococci on the strength of their presence in cultures from the nasopharynx. This cannot be accepted as an argument of any weight in view of the now known frequency with which streptococci occur in this position. The great enlargement of the cervical glands and the enlargement of the spleen and other glands, together with the rarity of suppuration and the very low mortality, is not consistent with a streptococcal origin. Even when some pharyngitis is present, it is characteristic of glandular fever that the size of the cervical glands is out of proportion to the symptoms and signs in the fauces.

Most French writers refuse to accept glandular fever as a disease *seu generis*. Thus Gallois regards it as only "a special form of influenza," and Labbé as a "cervical adenitis due to a naso-bucco-pharyngeal infection similar to any other acute adenitis." Combemale believed it to be Hodgkin's disease, but the subsequent history of the patients, which in some cases has been watched over prolonged periods, is against this view. Von Starek, noting the occurrence of constipation and of final diarrhoea, discusses the possibility of an auto-intoxication from the bowels. Subsequent writers have often quoted him as accepting this origin, but reference to his article shows that he rejected it.

It appears that glandular fever must be accepted as an acute infection and as a general and not merely a local infection. Further, there is no evidence to connect it with any of the better known acute infectious diseases, and we agree with those who regard it as a disease *seu generis*.

Various epidemics have been recorded which more or less resemble glandular fever. Breinl, Priestley and Fielding described in 1914 an endemic glandular fever which occurred in North Queensland, and was known locally as Mossman River fever. Many hundreds of cases have occurred since 1877. Adults are principally attacked, and it is rare in children. The onset is gradual, with pyrexia for ten or more days, the glands enlarge slowly, and the axillary and inguinal glands are mainly affected. At the onset the blood is normal, but about the end of the first week leucocytosis develops, the white cells being 12,000 to 15,000 per c.mm., with 45 per cent. of lymphocytes, and there is some degree of anaemia. The mortality is under 1 per cent. The glands show a simple adenitis. It is supposed that the infection is spread by mosquitos. It is evident that this is not glandular fever of the type which we are discussing.

Several writers have described outbreaks of epidemic cervical adenitis, especially Sharp, Pruett and Kirkland in 1913 and 1914. The changes in the fauces were marked, tonsillitis was common with exudation or even membrane formation, but diphtheria bacilli were not present. Tonsillar abscess was not infrequent. The cervical glands alone were affected and the spleen was not enlarged. Kirkland says that blood cultures, when positive, and swabs from the throat, showed streptococci. These epidemics would appear to be a definite infection of the tonsils with secondary enlargement of the cervical glands, and the clinical symptoms and course do not agree with glandular fever.

DIAGNOSIS.

Diagnosis has to be made from mumps, acute cervical adenitis secondary to septic foci, acute leukaemia, exanthemata, acute lymphadenoma, syphilis, tubercle, and possibly influenza.

From mumps, glandular fever is distinguished by the position of the initial and main enlargement of the glands being below the angle of the jaw, and by the freedom of the salivary glands, the parotid and submaxillary. The tissues of the neck are not oedematous, and much pain is rare. A previous attack of mumps may have occurred. It must be noted that, though the salivary glands invariably escape, certain lymphatic glands in proximity to them may be involved, producing the impression that the salivary glands are affected. Thus, in one of our cases, the superficial submaxillary lymphatic gland was greatly enlarged and produced a large prominence on the jaw, but examination easily proved that this was not the salivary gland. Possibly the pre-auricular lymphatic gland may sometimes be enlarged, and no doubt an erroneous diagnosis of mumps might be suggested.

Should a blood count be made, the combination may be present of enlarged cervical and other lymphatic glands, enlarged liver and spleen, together with a certain degree of leucocytosis and a greatly increased percentage of lymphocytes. Such a group of phenomena was actually present in one of our cases, and naturally suggested the possibility of acute leukaemia. It is not uncommon in the early stages of acute leukaemia, especially the lymphoid type, for the leucocytes to be only slightly or not at all increased in number. It was noteworthy that the severe symptoms associated with acute leukaemia were entirely absent. The general condition was good, the mooth was clean (oral sepsis is practically invariable in acute leukaemia), there was no vomiting, no purpura and no haemorrhages. Further, the degree of anaemia was very slight, and the stained red cells were normal, neither nucleated cells nor abnormal forms of any type being present, nor were any abnormal leucocytes recognized.

It is almost inconceivable that acute leukaemia could produce such a picture. It was our opinion from the first that this case was glandular fever, but as neither of us was aware of having seen an instance previously, and as we could find no information on the condition of the blood we hesitated to give a good prognosis for some days. There can be little doubt that similar cases sometimes have been regarded in the past as acute lymphoid leukaemia and probably have been recorded as cures. Many of those who have had much experience in diseases of the blood will be able to recall such events. It is well known that marked lymphocytosis also occurs in whooping-cough.

The distinction of glandular fever from acute cervical adenitis secondary to septic infection may be difficult, but there are numerous points of difference which, taken together, should lead to a correct diagnosis. Attention may be directed to the absence of septic foci in the fauces, scalp, ear and elsewhere in glandular fever, to the site of the main glandular enlargement, to the freedom of the skin and subcutaneous tissues, to the rapidity of diminution of the cervical glands and of the fall of temperature, to the rarity of suppuration, and also to the good general condition which may be combined with general glandular enlargement, a palpable spleen and a very high percentage of lymphocytes. The diagnosis from acute tuberculous adenitis might, presumably, have to await the progress of the case.

From scarlet fever and other exanthemata glandular fever is distinguishable by the large size of the cervical swelling, by the absence of changes in the tonsils and fauces, and of toxic symptoms, and by the absence of rash.

TREATMENT.

In the acute stages only symptomatic treatment is necessary. If the cervical glands are painful, compresses, hot or cold, may be applied, or glycerin of belladonna. Constipation should be treated by simple remedies, and there is no indication for the drastic methods recommended in the past.

As convalescence is often prolonged, as some degree of anaemia may develop and a poor state of health may persist for several months, care must be taken, especially with delicate children, and tonics of iron and cod-liver oil and malt should be administered. There is no reason to believe that nephritis becomes chronic, but our knowledge of this complication at present is scanty, and it is advisable to treat it with the same care as an ordinary nephritis.

Glandular fever must be regarded as infectious, and patients should be isolated. A period of fourteen days may be suggested for isolation and a similar period for quarantine.

BIBLIOGRAPHY.

Lists of references will be found in the articles by Schäffer, Trautmann, Korsakoff, and Dawson Williams. In conjunction with these, the following list forms a fairly complete bibliography of glandular fever, though many additional cases doubtless occur in the literature under titles of "acute leukaemia with recovery," "aberrant mumps," "infective mononucleosis, etc."

- Alerand: *Tuberc. inf.*, Paris, 1905, viii, 125.
 Baumann: *South African Med. Journ.*, 1913, xi, 303-306.
 Beale: *Texas State Journ. Med.*, 1911-12, vii, 222.
 Breinl, Priestley and Fielding: *Med. Journ. of Australia*, 1914, i, 391.
 Brelet: *Oaz. Méd. de Nantes*, 1913, xxxi, 761.
 Brown: *Med. Council*, Philadelphia, 1900, xv, 88.
 Butler: *Maritime Medical News*, Halifax, 1906, xx, 418.
 Burns: *Arch. Int. Med.*, 1909, iv, 118.

- Byers: *BRITISH MEDICAL JOURNAL*, 1904, i, 71.
 Campbell: *Montreal Medical Journal*, 1907, xxxvi, 325.
 Chierici: *Il Policlinico*, 1907, xiv, 337.
 Clemens: *British Journ. Dis. Children*, 1907, iv, 507.
 Crane: *Ohio Medical Journal*, 1908, iv, 143.
 Crawford: *Journal Iowa State Med. Soc.*, 1911, i, 205.
 Darcy: *Iowa Medical Journal*, 1911, xviii, 129.
 Davenport: *Lancet-Clinic*, Cincinnati, 1913, ex, 329.
 Davis: *Texas Medical News*, 1910, xv, 148.
 Deicourt: *Policlin.*, Brus., 1905, xiv, 108.
 Dercum: *Therap. Rev.*, Philadelphia, 1904, i, 204.
 Dolloway: *Am. M. Comp.*, Toledo, 1903, xix, 18.
 Domenici: *Riv. Med.*, Milan, 1910, xviii, 1.
 Garlock: *New York State Journal of Medicine*, 1909, ix, 256.
 Haas: *Amer. Journ. Obstet.*, 1912, lxxv, 355. *Amer. Journ. of Diseases of Children*, 1912, iii, 241.
 Hamill: *Musser and Kelly's Handbook of Treatment*, 1911, ii, 640.
 Hand: *Arch. of Pediatrics*, 1900, 754.
 Jackson: *Lancet*, 1897, ii, 979.
 Kirkland: *BRITISH MEDICAL JOURNAL*, 1914, i, 419.
 Korsakoff: *Arch. f. Kinderheilk.*, 1905, xli, 321.
 Kucera: *Lek. rozhledy, Praha*, 1906, xiv, 4.
 Kühner: *Kinder-Arzt*, Leipzig, 1908, xix, 121.
 Likes: *Med. Council*, Philadelphia, 1914, xix, 35.
 Lubinski: *Zeitsch. f. Klin. Med.*, 1907, lxxviii, 170.
 Marshall: *Maryland Journal*, 1906, xlix, 388.
 Matheson: *Lancet*, 1904, i, 204.
 Moebius: *Muench. med. Woch.*, 1905, liii, 1575.
 Morichau-Besuchant: *Pediatric prat.*, Lille, 1908, vi, 223.
 Pfeiffer: *Jahrb. f. Kinderheilk.*, 1889, xxix, 257. *Verhandl. d. Kongr. f. inn. Med.*, 1908, xxv, 539.
 Pfeue: *BRITISH MEDICAL JOURNAL*, 1914, i, 416.
Rassegna Med., Bologna, 1907, xv, 1.
 Robertson: *New Zealand Medical Journal*, 1909, viii, 1.
 Roux et Jossierand: *Rev. mens. des mal. de l'enfance*, 1903, 351.
 Rudolf: *BRITISH MEDICAL JOURNAL*, 1914, i, 84.
 Schäffer: *Hosp. Tid.*, Copenhagen, 1908, i, 1200. *Jahresb. f. Kinderheilk.*, 1908, lxi, 526.
 Schleissner: *Wiener klin. Woch.*, 1911, xxiv, 310.
 Soca: *La méd. infantile*, 1895, ii, 101.
 v. Starck: *Jahrb. f. Kinderheilk.*, 1890, xxxi, 454.
 Stark: *BRITISH MEDICAL JOURNAL*, 1914, i, 195.
 de Stella: *Belgique méd.*, 1906, xlii, 507. *Rev. hebdom. de Laryngol.*, 1906, i, 145. *Belgique méd.*, 1913, xx, 339.
 Stutsman: *Journ. Iowa State Med. Soc.*, 1911, i, 367.
 Terfinger: *Journ. Amer. Med. Assoc.*, 1908, 1, 755.
 Torrier: *Journ. de Méd. int.*, Paris, 1910, xiv, 201.
 Trautmann: *Jahrb. f. Kinderheilk.*, 1904, lx, 503. *Muench. med. Woch.*, 1905, p. 23.
 Vipond: *Arch. of Pediatrics*, 1906, xxiii, 11.
 West, Park: *Arch. of Pediatrics*, 189-, xiii, 889.
 Whitney: *Colorado Med.*, 1914, xi, 157.
 Williams, Dawson: *Lancet*, 1897, i, 150.

ON UNUNITED FRACTURES.

BY

G. W. BERESFORD, O.B.E., F.R.C.S.,
 SURGEON, RED CROSS HOSPITAL, BRIGHTON.

A FRACTURE which shows no evidence of bony union at the end of twelve months may be regarded as a case of non-union. To treat any disorder efficiently it is necessary to obtain a clear idea of the condition to be remedied and its cause, for the treatment will largely depend upon the removal of the cause.

The Condition to be Remedied.

Normal bone, like all other tissues, is constantly undergoing a steady process of absorption and reformation, the resulting structure accommodating itself to the function to be performed. The inflammatory process of bone is modified by the vessels being enclosed in rigid channels. This delays the formation of granulation tissue and also the removal of damaged tissues. To overcome this disability Nature appears to have provided a special mechanism for absorption—namely, osteoclastic. It would appear that the same processes which stimulate the osteoclastic element very often coincidentally stimulate the bone-forming process—that is, osteoblastic—into activity. Bone is only a specialized type of connective tissue, and osteoblasts in early stages are indistinguishable from fibroblasts; it is not surprising that fibrous union is not uncommon. It is well known that the pituitary and also thyroid gland secretions have an important influence upon bone formation. Pituitary secretion particularly produces a hypertrophy of interstitial growth of bone.

The chief features noted on examination of the ununited fractures are: atrophy of the bone; loss of vascular supply; sclerosis of surrounding soft tissues and the bone ends.

Causes of Non-union.

The causes of non-union may be conveniently divided into two main groups.

Group I.

- Some upset between the osteoclastic and osteoblastic elements possibly due to derangement or abnormal internal secretions.
- Diense.
- Defective blood supply.

Group II.

(a) Non-apposition of fractured ends from various causes—for example, interposition of soft structures; over-extension with weights; loss of bone.

(b) Movement between apposed ends.

(c) Prolonged severe infection.

With reference to Group I: Comparatively little is known about (a), but pituitary extract is certainly worth a trial; (b) is an important factor, and everything possible should be done to encourage use consistent with prevention of movements at the site of fracture. It is here that massage plays an important part. As regards (c) the blood supply may be injured originally or later cut off by formation of fibrous tissue, and either of these conditions certainly leads to very delayed union.

Under Group II are classed those causes of non-union which may be called lack of opportunity. The non-apposition of fractured ends is, I think, by far the greatest cause of non-union, and this is, in the great majority of cases, produced by the interposition of some soft structure.

The practice, as was advocated by Leriche, of wholesale removal of all bony fragments in compound comminuted fractures is to be condemned.

Movements between the fractured ends is, I believe, another very common cause of non-union or delayed union, and I venture to state that far more damage has been done by neglect of really adequate splinting than good has accrued by the much vaunted early movements, which have often been instituted regardless of all other considerations.

Treatment.

Due regard must be paid to the general condition of the patient. Inducing the patient to drink large quantities of milk and the giving of calcium salts I believe to have no beneficial effects. Doses of anterior lobe of pituitary, 10 grains daily, by mouth, of fresh gland, or subcutaneous injections of extract of anterior lobe, are well worth a trial, especially in those cases of delayed union which are particularly common in the tibia. During the administration of pituitary the urine must be examined for sugar, and the administration stopped or dose reduced if glycosuria becomes marked. I have not as yet got sufficient data to make any positive statements on the influence of pituitary extract.

The most important part of the treatment will be that directed to the local condition. Here massage and electrical treatment are important to improve and maintain nutrition and keep all the surrounding structures in good condition. Movement and use should be encouraged whenever possible—for example, the wrist and hand in cases of ununited humerus. Where infection is still present this must be cleared up, and an interval of at least three months allowed after healing; during this time special attention should be paid to all joints and soft structures, and use of the whole part encouraged, a temporary splint or support being used the while to allow of maximum use. Deformities should be corrected where present.

This delay for the clearing up of slightly infected cases is not always a necessity; it depends upon the type of operation contemplated. I have treated several cases of non-union of humerus in which there has been a sinus, and obtained excellent results by a step operation or dovetailing and providing drainage.

It is sometimes desirable to perform two operations. At the first scar tissue is excised and the sclerosed ends of bone removed; the wound is then completely sutured and the main operation done a month later. This preliminary operation is the more indicated in those cases where prolonged infection has been present and a bone graft is contemplated, for it will serve not only the purpose of eliminating unhealthy tissue, but also as an indicator that infection is absent.

Injured nerves are best dealt with after union has taken place and proper treatment can be devoted to the part; it is seldom possible adequately to treat the two conditions concurrently. Of course, nerves merely caught in between the bone ends and adherent must be freed, but, on the whole, I prefer to interfere with the nerve as little as possible at the time of operating on the fracture.

The operation consists in (1) attaining apposition; (2) retaining apposition without possibility of movement between the ends.

The fractured ends are exposed by the most convenient route consistent with minimum injury to muscles, nerves, and vessels. The ends are then freed from all fibrous tissue. Most or all of the sclerosed bone is removed and several holes made with a fine drill. The method of actually attaining apposition will depend upon the bone and the condition of the bone ends—for example, 3 in. shortening of a humerus is a trifling matter causing little disability, but it would be a most crippling

deformity in a tibia. The methods employed are (1) the "slot or dovetailing" method, (2) the "step" method, (3) the sliding bone graft, and (4) bone transplantation, the slot being filled with an accurately fitting piece of bone cut from some other bone, usually the tibia.

The last is the most successful type of bone transplantation to use. Intramedullary pegs of bone, where they are used to bridge a gap, are prone to fracture after a period of time. Sometimes it may be desirable to transplant a whole piece of bone—for example, a piece of fibula. Speed is of importance directly bone is exposed, as it dries very quickly, and to prevent this the parts must be kept bathed with warm normal saline. In every case the ends are securely bound together by drilling holes and using thick thirty-day chromic catgut. When this has been done quite good stability is obtained, and the operation cannot be regarded as satisfactory unless this is so, particularly in cases of bone graft.

It is to be noted that many patients have a rise of temperature for a few days after the operation, but this is not to be taken as an indication for opening up the wound unless the rise of temperature is maintained. In a few cases where there is extensive scarring, the skin may slough, and this condition is best treated with spirit dressings, thereby the necrosed area is kept sterile and in a short time an aseptic scab will be formed without infection of the deeper tissues of the wound.

The whole limb is then put up in plaster, paying particular attention to fixation of the joint above and below. On no account should plates, wires, screws or other non-absorbable substances be used—they are unnecessary and almost without exception injurious. A radiogram, through the plaster, may be taken in a day or so, to see that all is well.

In cases where dovetailing or step operation has been performed the plaster can be removed at the end of six to eight weeks and a radiogram taken, after which the plaster is reapplied. It is usual to find that there is sufficient union to permit of limited movements being instituted in one of the joints. At the end of three months the plaster can be replaced with a detachable support, applied to afford protection from severe strains, but allowing of free movements of all joints. During this period the patient is encouraged to use the limb, and massage and electrical treatment is applied.

After a bone graft or transplantation, it is wise not to remove the plaster before the end of three months, and it should then be reapplied for another three months and a protective splint used for a further period. The time in plaster will depend upon the condition found in the radiogram.

The length of time during which a bone has been ununited seems to have little influence upon the ultimate prognosis, and a period of years of non-union should not deter one from operating with a reasonable certainty of a good result.

BIBLIOGRAPHY.

Albee and Weigel: *Journ. Amer. Med. Assoc.*, vol. 74.
 Groves, E. W. H.: *Bristol Med.-Chir. Journ.*, December, 1919, *Lancet*, 1920, i, p. 1048.
 Estes, W. L.: *Amer. Surg.*, Phil., 1920.
 Gill, A. B.: *Transactions of Phil. Acad. of Surg.*, November, 1919.
 Dupuy de Fenelle: *Paris Chirurg.*, 1919, xi, 112 and 183.
 Leriche and Polleard: *Bull. et Mém. Soc. Anat. de Paris*, 1919, LXXXIX.
 Cushing: *The Pituitary Gland and its Disorders*, 1911.
 Blair Bell: *The Pituitary*, 1919.

THE TREATMENT OF HAEMORRHOIDS BY ELECTROLYSIS.

BY

J. CURTIS WEBB, M.A., M.B., B.Ch.

In the earlier part of 1914 I read a paper at the Royal Society of Medicine on the treatment of haemorrhoids by electrolysis, and I referred there to the very satisfactory results which I had obtained by this method. During a great portion of the four and a half years of the war, which I spent in Boulogne, I had many opportunities of carrying out this treatment, and the more I see of its results the more convinced I am that, in suitable cases, it is the method of election for this very troublesome complaint. For the sake of convenience haemorrhoids may be divided into three classes:

1. *External*, which occur at the mucocutaneous margin of the anus, and are due to varicosity of the inferior haemorrhoidal branches. These as a rule give no trouble unless they become

inflamed and thrombosed, and for such I believe the best treatment is an incision and removal of the clots.

2. *Internal*, which do not prolapse, and which give rise to symptoms of haemorrhage and a dragging pain. The operation for this condition is severe—though not usually accompanied by danger and painful, and I have found that the large majority of such cases can be cured by applications of the high frequency vacuum tubes, aided by suppositories containing adrenaline.

3. *Intero-external*, which prolapse and become "nipped" by the sphincter, giving rise to great pain, and, frequently, both haemorrhage and discharge. These, and true internal haemorrhoids, are usually dilatations at the junction of the superior and middle haemorrhoidal veins.

It is for the last named very common type of pile that patients usually apply for relief, and for which sedative and astringent ointments and suppositories afford little permanent benefit.

I am convinced that the treatment by electrolysis is the most certain and the least painful. No general anaesthetic is required, and the patient is not confined to bed, as a rule, for more than twenty-four hours at most. There is no pain on defaecation after the treatment, nor reflex difficulty in emptying the bladder, and the cure, as far as the haemorrhoid treated is concerned, is permanent. The prolapsed pile is treated in the manner to be described, and the patient then left alone for ten to fourteen days. If at the end of that time there is another haemorrhoid in evidence it can be treated in a similar manner, but I have never had to administer more than three treatments in any case, and this only on one occasion.

Method.

The patient, having had the bowels thoroughly cleared out by an aperient over night and a saline in the morning, is placed on the left side, and a large indifferent electrode, connected to the negative terminal of a source of constant current, is applied over the right buttock and hip, taking care that it is in close apposition with the skin. If the haemorrhoid is not fully prolapsed the patient is asked to strain to bring it down. The pile is now painted with a mixture of phenol gr. 30, menthol gr. 30, quinine hydrochlor. gr. 22, adrenaline gr. 1/100, which I have found to be the best "surface anaesthetic," and after a minute or two it will be found that a local anaesthetic can be injected into the tissue below the base of the haemorrhoid without pain, provided that a sharp fine needle be employed. I usually employ sol. urea and quin. hydrochlor. (Parke, Davis and Co.). After about ten minutes the pile is completely anaesthetic, though almost immediately after being painted it can be painlessly grasped with artery catch forceps to prevent its retraction. Two or three long zinc needles, or thin spears made from "slivers" of sheet zinc and soldered to flexible insulated wire, are thrust into the base of the pile parallel to its long axis, and several more into the substance of the pile. All these needles are connected to the positive pole of the source of current, and are packed round with oiled wool to prevent their causing blisters on the parts round the anus. The current is now slowly turned on till a strength equal to about 12 to 15 milliamperes per needle is reached, and is allowed to flow for ten or fifteen minutes and then gradually turned off. It will be found that the needles are quite difficult to withdraw owing to the firmness of the clot formed, and it is often well to reverse the current, making the needles negative, for a couple of minutes to facilitate withdrawal.

After the treatment the pile has changed from purple red to grey. It is covered with adrenaline and chloretone ointment and pushed well up into the rectum, and a suppository of chloretone gr. 5, morphine gr. 1/4, and novocain gr. 1/4 inserted. The patient is sent home with directions to go to bed for twenty-four hours, to take a dose of senna and sulphur the following night, and is also instructed that, should the pile prolapse, it must be replaced at once.

The process by which the haemorrhoid is cured is twofold. The vasa vasorum are obliterated, and thus the blood supply is cut off from the walls of the vein, and at the same time a firm, closely-adherent clot is formed in the lumen of the dilated portion.

Advantages of the Method.

1. It is practically painless at the time of treatment.
2. There is very little, if any, pain afterwards.
3. The patient is not kept away from his work.

4. There is no risk of separation of the clot as far as my experience goes, or in the experience of others who have used this treatment.

5. There is no necessity to dilate the sphincter.

I do not consider this treatment is indicated in cases where the piles do not protrude, nor when they are very large.

I do not propose to quote a series of cases, but two recent ones are typical:

A lady, 75 years old, had for two years suffered from small prolapsing haemorrhoids, constant discharge from the anus which stained her linen, and intense pruritus. Two treatments at an interval of ten days, which caused her absolutely no pain either at the time or afterwards, has effected a complete cure of the haemorrhoids, of the discharge, and of the pruritus.

A medical man in busy general practice who had had a prolapsing pile for eighteen months, and discharge and pruritus, was treated on a Saturday afternoon. He had some pain that night, but visited his patients on Sunday and every subsequent day. He has had no trouble since that one treatment.

These results are typical of what one may expect with careful technique in suitable cases.

TUBERCULIN IN EPILEPSY.

BY

JAMES CROCKET, M.D., Ch.B., D.P.H.,

LECTURER ON TUBERCULOSIS, GLASGOW UNIVERSITY; MEDICAL SUPERINTENDENT, CONSUMPTION SANATORIA OF SCOTLAND AND COLONY OF MERCY FOR EPILEPTICS, BRIDGE OF WEIR.

For many years we have administered tuberculin with excellent effects to at least two hundred patients each week. These patients chiefly suffer from chronic ulcerative pulmonary tuberculosis and tuberculous adenitis, and are resident in the Consumption Sanatoria of Scotland, the Colony of Mercy for Epileptics, and the Orphan Homes of Scotland, Bridge of Weir, Renfrewshire.

Two cases particularly are interesting, and deserve to be recorded. Some textbooks on the subject of tuberculin mention epilepsy as a contraindication to its administration. Our experience shows that, so far from that being so, it is a decided indication for its use, especially under two circumstances: (1) the presence of a tuberculous lesion, active or quiescent; (2) a family history of tuberculosis.

Six and a half years ago we began to give tuberculin to a patient A. D., who was 32 years of age, who had suffered from epilepsy of the major type since the age of 7, and who had a large mass of tuberculous glands below the right ear with several discharging sinuses; the mass was as large as a closed fist. There was a smaller mass supraclavicularly on the left side, and chronic pleurisy at the left base. No other change was made in the patient's life—the environment, work, and drug treatment were the same as had been the case for many years. We hoped by tuberculin to help the tuberculous condition, and had no thought of it benefiting the epilepsy. In the course of a year and a half the glands disappeared entirely and the pleurisy cleared up. *Pari passu* with the disappearance of the tuberculous lesions, the epileptic fits became fewer and after two and a half years ceased entirely, and the patient likewise improved mentally. When the fits had been absent for a period of three years the patient was discharged from the colony, and she took up work as a domestic servant. We have kept her under observation and under tuberculin treatment during the year, and she has remained perfectly well. For four years thus, apparently as the result of this one new factor—the administration of tuberculin—this patient has been free both from tuberculosis and from epilepsy.

Encouraged with the results of treatment in this case, about eighteen months ago we began to administer tuberculin to several other epileptics who had no clinically obvious or apparent tuberculosis, but gave a family history of tuberculosis. One of these (F. A.) has responded excellently. He was 14 years of age, and had had epilepsy for an indefinite period—the father could not tell how long. His mother had died of consumption. The fits were very severe in character, and one month no fewer than 338 were recorded—309 major and 29 minor. He was decidedly weak-minded, and was certified under the Mental Deficiency Act (1913) as a mental defective. Tuberculin was first given to him in November, 1919. For nearly fourteen months he has had no signs of epilepsy, and mentally he has also improved. The records of his case show that previously he was pugnacious and irresponsible, but during the past year he has been well behaved, and fairly industrious.

Five others, to whom tuberculin has been given for six to twelve months, show a diminution in the number and in the severity of their seizures. Three show no change. We have begun to give tuberculin to a hundred epileptic

patients, ignoring the presence either of a tuberculous lesion or of a hereditary strain. It is well-known that *post-mortem* results point to the vast majority of those who attain maturity presenting tuberculous lesions at some part. It will be interesting in course of time to note the results.

The action of the tuberculin in epilepsy as demonstrated in those cases is uncertain. It may be due to its specific effect on some tuberculous growth in the neighbourhood of the cortex. It may be that epilepsy that is tuberculous in origin is of the Jacksonian type. This drug certainly does lead to the resolution of masses and of adhesions which are palpable, and such masses or adhesions may reflexly lead to the onset of epileptoid seizures.

The tuberculin used was Burroughs, Wellcome and Co.'s B. E. and P. B. E. mixed in equal parts, and it was given in doses beginning at 0.00000001 c.c.m., gradually increased to 0.4 c.c.m. The injections were given at intervals of seven days to begin with, and later of fourteen days. The treatment has gone on without any intermission. General reactions have been avoided, but once or twice local reactions of a rather severe type occurred when large doses of bacillary emulsion were given. On two occasions cold abscesses formed, which had to be aspirated.

REFERENCE.

¹Tuberculin in Diagnosis and Treatment. Seventh edition, p. 233. (Händler and Roepke.)

Memoranda:

MEDICAL, SURGICAL, OBSTETRICAL.

SAPRAEMIC GLYCOSURIA.

I HAVE read Dr. C. G. Higginson's article on supraemic glycosuria (February 26th, 1921, p. 296) with interest, as I have at present under my care a patient who developed glycosuria shortly after a carbuncle appeared on his neck.

My patient, a stout and previously healthy man of 64, consulted me some three weeks ago for a large boil on the nape of his neck. His urine contained no trace of sugar. In spite of topical applications the carbuncle spread rapidly, and I made a deep crucial incision throughout its extent; it continued to spread until it extended almost from ear to ear, with a breadth of some 3½ in. He was seen by a surgeon, who excised the whole of the affected tissue, leaving a large gaping wound.

Previous to the operation I volunteered the information that there was no glycosuria. Two days later the patient complained of thirst; the temperature was subnormal throughout. I again examined the urine, and found that it contained 17 grains of sugar per ounce. A diabetic regimen reduced the sugar to 4 grains per ounce in twenty-four hours, and in forty-eight hours it had completely disappeared, and has not been present since. After a period on strict diet the patient returned to ordinary diet; in spite of this he has had no further glycosuria.

Some two years ago I saw another patient with a tiny black patch on his great toe; he had 54 grains of sugar per ounce in his urine. Gangrene set in with great rapidity in spite of strict diet, and soon involved the whole foot; he also began to exhibit symptoms of impending coma. He fasted completely for four days, when the amount of sugar became reduced to 4 grains per ounce. He was then put for a time on a diet, gradually increased, of eggs and French beans, and the sugar soon disappeared. I eventually amputated his foot. He did well, and now gets about with an artificial limb. With a diet containing no sugar, but with a moderate amount of bread and one potato daily, his urine remains sugar-free, but on one occasion when he exceeded his limit of starchy food, sugar reappeared freely, to disappear again on resumption of previous restrictions.

Some years ago I had a case of carbuncle in a diabetic which, in spite of dietetic restrictions current at the time, continued to spread, the patient eventually dying of diabetic coma.

There would appear to be two types of cases—one in which the carbuncle or gangrene is the sequel to the diabetes, and the other in which the carbuncle or gangrene is the causative agent of a supraemic glycosuria, or perhaps coincident with and due to an intermittent glycosuria.

I shall be interested later on in estimating the sugar tolerance of my present patient, but shall prefer to wait for his complete recovery. The success of the Allen treatment, as expounded by Dr. Leyton, in my case of gangrene has made me think that such treatment might be generally useful in cases of diabetic gangrene, whether the gangrene be cause or effect.

Old Hill, Staffs.

THOMAS E. MITCHELL, M.B.

IN the BRITISH MEDICAL JOURNAL of February 26th Dr. Charles Gaskell Higginson finishes his paper on supraemic glycosuria with the sentence:

"At present gangrene and carbuncle are the most striking and misleading agents in the causation of supraemic glycosuria, but further investigation will doubtless reveal a long series of such agents differing from each other very much in the power of causing supraemic glycosuria."

This prophecy has led me to record some observations which may throw a light upon the condition. The percentage of sugar in the blood of a healthy man six hours after food may be taken as 0.11, and although sugar may appear in the urine with this blood sugar, it is the exception rather than the rule; usually the blood sugar is above 0.18 per cent. in glycosurics. In pyrexia the blood sugar rises above the normal, and this is so well known that the appearance of glycosuria gives but little more anxiety than albuminuria in pyrexia.

Everyone who has had experience in the treatment of diabetes realizes that toxins produced by most infections modify metabolism sufficiently to lead to a return of sugar in the urine whilst the patient maintains the diet which was the optimum, and had permitted the blood sugar to fall to normal. The quantity of toxin may be small. I have seen the injection of one hundred million dead bacilli cause glycosuria in a woman who was upon a diet of only half her optimum. The reappearance of sugar in a diabetic child permitted of the correct prophecy, three days before their appearance, that she would develop the spots of elhicken-pox. (The sister was convalescent from that disease.)

The supraemia of pyorrhoea alveolaris is so common and important a factor in diabetes mellitus that extirpation of the infection has often led to the disappearance of glycosuria with but an insignificant modification in diet. The evidence upon which this is based is rather lengthy. The causes of glycosuria are so numerous that any tentative explanation offered is offered with all humility. It seems to me probable that one form of diabetes mellitus is due to a deterioration of the cells of the islands of Langerhans in the pancreas. This deterioration is sometimes due to a direct infection accompanied by a slight pyrexia for a few days. Some of the cells are destroyed, some impaired, and others left normal. The impaired cells have a reduced vitality and may be paralysed or destroyed by various toxins. Chloroform and ether often destroy them and turn a mild diabetes into a severe one. A mild toxin may lead to a temporary glycosuria from which recovery may be complete. I tend to the view that supraemic glycosuria and glycosuria due to non diabetic gangrene are simply two varieties of toxic glycosuria.

London, W. O. LEYTON, M.D., D.Sc., F.R.C.P.

NORMAL DELIVERY AFTER TRAUMATIC RUPTURE OF UTERUS.

IN view of the interest aroused by the discussion at the Royal Society of Medicine, in May of last year, on spontaneous rupture of the uterus during labour, following Caesarean section, I think the following case, unique I believe, will be of interest.

A married woman, aged 22, five months pregnant, fell from a railway platform on to the rails, rupturing the uterus. I examined her two, seven, and eleven hours after the accident, and the uterus appeared normal. As at the last examination she showed symptoms of internal haemorrhage, I diagnosed concealed haemorrhage, and, turning her on to the left lateral position, tried to rupture the membranes. As I was unsuccessful in this, I got Dr. Gordon Ley to see the case. He saw her fifteen hours after the accident, and decided to open the abdomen. When this was done, he found the uterus ruptured on its anterior surface for about 9 inches, and the foetus and membranes lying in the abdominal cavity. I believe the foetus had slipped out of the uterus, when I put the patient into the left lateral position, eleven hours after the accident. The foetus, placenta and membranes were removed, the uterus stitched up with two layers of No. 3 chromicized catgut, the abdominal cavity swabbed out, and the abdomen closed. Nineteen months later the patient became pregnant and was delivered after a normal labour at full time. The placenta was somewhat adherent

and she had fairly severe haemorrhage after its removal. This was controlled by an injection of pituitary. Otherwise the puerperium was normal.

I believe this is the first case of normal labour following traumatic rupture of the uterus to be reported.

Woking.

R. THORNE THORNE.

Reports of Societies.

CONGENITAL SYPHILIS.

THE discussion on congenital syphilis which was opened on February 25th in the Section for the Study of Disease in Children of the Royal Society of Medicine (BRITISH MEDICAL JOURNAL, March 5th, p. 342), was concluded at a further meeting on March 16th.

Dr. H. MORLEY FLETCHER remarked that in his experience of the last twenty-five years in London congenital syphilis appeared to have undergone considerable modification. The number of infants with frank manifestations of syphilis, such as skin eruptions and condylomata, was much less than it used to be, although this did not imply a diminution in case-frequency, only a change in type. He had not seen a single instance in which a positive Wassermann reaction had followed a provocative injection in a child, nor had he met a case with a positive reaction in the cerebro-spinal fluid in a child when the blood reaction was not also positive. In syphilitic children, especially during the first few years of life, the resistance to infection generally was lowered. The association of congenital syphilis with tuberculosis was not sufficiently appreciated. Lymphadenitis was the form of tuberculous disease he had seen most frequently in syphilitic children. In tuberculous cases in which there was any family history of syphilis, or in which any stigmata were present, the Wassermann test should be done. One of the most striking features of syphilis was the widespread nature of the lesions it caused. He dealt in particular with the morbid changes in syphilitic kidney, which in the stillborn foetus showed evidence of arrested development, and there was similar evidence in the infant, together with the beginning of sclerosis, which became more diffuse as the age advanced. Syphilis should always be borne in mind in cases of renal disease in children. He believed that larger doses of mercury, of which children were tolerant, should be given.

Dr. JOHN ADAMS gave some further particulars of his work in the clinic at Thavies Inn, to which many references have been made in this JOURNAL. During the last year, of the 37 pregnant women admitted with syphilis and treated, all gave birth to living children, 36 of whom showed a negative Wassermann reaction and one a positive. The treatment of congenital syphilis in older children was very unsatisfactory, but ante-natal and post-natal treatment was most encouraging. He had not seen a case of secondary syphilis in a child during the last two years in the clinic over which he presided, and if there were no manifestations of syphilis within the first twelve months one might be confident that there would be none afterwards. When a woman of seven months' pregnancy contracted syphilis, the child appeared to be born healthy without ante-natal treatment, and to remain negative to the Wassermann test, doubtless owing, as Dr. Amand Routh had suggested, to some ferment in the placenta which had the power of intercepting and destroying the syphilitic virus. Dr. Adams urged that lying-in centres should be established in every large town, with medical officers specially appointed to look after them.

Dr. R. C. JEWESBURY gave an account of the clinic at St. Thomas's Hospital, which was started rather more than a year ago for the treatment of children suffering from congenital syphilis. He reproduced a number of family histories, including the regular type—that is, a number of miscarriages followed by live births, and ultimately, perhaps, by the birth of healthy children—and the irregular types, which followed no such progress. These two types were about equal in frequency. In a number of cases—about 10 per cent. of those investigated—in which the mother was syphilitic before the birth of the child, the child was born apparently healthy and continued without the appearance of any signs which called for attention until perhaps the tenth year or later, when symptoms—chiefly mental, such as dullness—developed; these cases

were the hardest of all to treat. The total number of cases treated in the year was 145. The mothers of all these children were known to be syphilitic, but in 9 cases the infection occurred after the birth of the child, so that the syphilis in the child was acquired. Only 47 of the mothers had had any treatment before or during pregnancy, and in only 39 of these cases was this treatment at all systematic. The results were as follows:

	Mothers Untreated.	Mothers Treated.
Cases investigated	77	59
Total pregnancies	322	53
Miscarriages or stillbirths	97	1
Infants died	73	6
Children still alive at time of investigation ...	152	46
Mortality of children born alive	32.4%	11.5%

Mr. J. E. R. McDONAGH said that at the Lock Hospital it had been found that if a woman had contracted syphilis up to the fifth month of pregnancy the chances were that the child would be born syphilitic; if in the sixth or seventh month, the chances were about equally divided; and if in the eighth or ninth month, the chances were that the child would be born not syphilitic. Many of the children in this last category, however, acquired syphilis after birth as a result of suckling, and he thought it well to assume that every child of a syphilitic mother was syphilitic. He did not look forward hopefully to the results of subsequent pregnancies in the case of women who had been treated during one pregnancy. Once a woman was syphilitic, the chances were, however much treatment she might receive, that she would be syphilitic in subsequent pregnancies.

Mr. H. NEAME gave some particulars of the results of the treatment of interstitial keratitis with arsenic in addition to ordinary mercury. He spoke on the basis of 24 cases carefully tested at the London Hospital. It was doubtful whether, if a patient came up for treatment before both eyes were affected, the treatment could prevent the infection of the second eye. In five of his cases the second eye became infected after treatment. He thought it reasonable to assume that arsenical preparations, if given in large doses, could prevent complications such as choroido-retinitis, seeing that the choroid was a vascular structure. His doses were generally 50 per cent. above the recognized doses for the size and weight of the child. He believed that when the interstitial keratitis was actually established the treatment was of benefit in improving the visual acuity in a very large proportion of cases, and he was sure that prophylactic treatment would be of much benefit in preventing interstitial keratitis.

Mr. A. T. PITTS, discussing the teeth in congenital syphilis, mentioned that out of some thousands of cases he had never seen Hutchinson's teeth in the milk dentition, though cases had been recorded, and there was no reason why, if the infection began early enough in the foetus, these should not occur. He suggested *a priori* that syphilis should be regarded as one of the causes of hyperplasia of the milk teeth, and any well-marked cases should arouse suspicion sufficient to warrant further investigation.

Dr. RONALD CARTER, who spoke from the general practitioner's point of view, said that there was a good deal of nervousness and jumpiness with regard to congenital syphilis. His own strong impression, from twenty-five years of general practice, was that congenital syphilis was comparatively rare, but the statistics lately given by Dr. Helen Campbell of Bradford caused some amazement and misgiving. He did not think that such statistics should be accepted unquestioningly.

Dr. F. LANGMEAD, the President of the Section, in reviewing the discussion, said that its most important feature was the general consensus of opinion as to the extreme value of the treatment of pregnant syphilitic women.

Sir HUMPHRY ROLLESTON, in replying, said that the change in the type of congenital syphilis, to which Dr. Morley Fletcher had drawn attention, was possibly due to some alteration in the strain of the spirochaete, which, instead of being attracted towards the skin, sought the viscera and nervous system. One interesting fact brought

out in the discussion was that acute infectious might stir up syphilis in a frank form. With regard to treatment, he thought that they had perhaps been too much afraid to push mercury to the extent that was desirable. He congratulated Dr. Adams and other workers in ante-natal and post-natal treatment on their results.

INSTRUMENTAL ABORTION.

A MEETING of the West London Medico-Chirurgical Society was held at the West London Hospital on March 4th, with the President, Dr. F. J. McCANN, in the chair. A paper was read by Dr. BERNARD H. SPILSBURY on instrumental abortion. Observing that abortion was a practice by no means confined to civilized communities, he instanced some of the crude methods in use amongst primitive races—for example, pummelling the abdomen with stones. For the production of abortion the most effective methods were those in which violence or other physical agents were applied directly to the uterus. Success depended on the amount of the local disturbance, and to some extent on the readiness of the uterine reaction—a factor which varied in different individuals. The following were some of the commoner methods used:

1. Passing an instrument into the cervical canal or into the body of the uterus. In self-attempted abortion the favourite instrument was a hat-pin, crochet hook, or a skewer. Skilled abortionists resorted to more suitable instruments, such as catheters. Without the requisite anatomical knowledge a woman was most unlikely to pass an instrument into her own uterus unless prolapse was present.
2. Intra-vaginal injections of various fluids.
3. Intra-uterine injections of fluids, of which soap solution was a favourite. Even scalding water had been used.
4. Blowing air through a catheter passed into the uterus.
5. Manipulation of the external os uteri with the hand.
6. Packing the vagina.
7. Abdominal massage of the uterus.
8. Local application of electricity.
9. Dilatation of cervix and immediate removal of the products of conception—chiefly employed by medical practitioners.

The dangers of instrumental abortion were three—infection, haemorrhage, and shock. Infection was favoured by the large raw surface in the uterus and the proximity of large blood vessels to the placental site. Streptococci and the colon bacillus were the most frequent infecting agents. In fatal cases the course of infection varied greatly. At the one extreme was a rapidly fatal septicaemia with little or no local suppuration, and at the other was a prolonged septicaemia ending in pyaemia. Septic pulmonary infarcts were common. Massive embolism of the pulmonary artery might occur. Haemorrhage alone was occasionally responsible for death when the placental site was damaged or the uterus perforated, but it was more frequently associated with septic infection in fatal cases. Shock often occurred at the moment of passage of an instrument into the uterus and was usually transient, but occasionally instant death occurred. This might also result from the injection of fluid into the uterus.

The PRESIDENT referred particularly to treatment of cases of attempted abortion. Treatment must be prompt and first directed to a thorough cleansing of the whole genital passages. If this proved ineffective there should be no hesitation in opening the abdomen and if necessary removing the uterus.

Dr. LAPHORN SMITH endorsed the President's statements, and pointed out that the doctor's first duty was to save the patient, and not to act as a detective. It was always wise in these cases to call in the aid of another practitioner both for his medical assistance and to avoid any appearance of secrecy. After cleansing the passages he advised the free use of powdered boracic acid in the vagina.

Dr. W. H. WILCOX congratulated Dr. Spilsbury on his comprehensive paper, and referred to Dr. Spilsbury's unrivalled experience of these cases during the past fifteen years. He said that frequently instrumental abortion was aided by ecbolic drugs given either before or after the mechanical interference. He was glad that two important points had been emphasized. The first was that the mere passage of an instrument into the pregnant uterus might cause sudden death; several instances of this had occurred in recent years. The second point was the extreme rapidity with which septicaemia often occurred, since in many instances septic organisms were directly introduced into the peritoneal cavity.

Dr. A. KNYVETT GORDON said that from his experience in the treatment of many cases of puerperal septicaemia he had come to regard the administration of large doses of antistreptococcal or anticolon bacillus serum (according to the bacteriology of the case) as the most valuable constitutional remedy we had. At least 100 c.cm. should be given in two pints of saline into the subcutaneous tissues. He strongly deprecated the use of vaccines in acute cases; it was wrong in theory and disastrous in practice.

Dr. J. A. MANSELL MOULLEN agreed with what had been said regarding early treatment. Free drainage of the infected uterus was imperative, with laparotomy if necessary. Dr. F. G. LLOYD said that these cases were always unsatisfactory from the practitioner's standpoint. He strongly advocated sharing the responsibility with another practitioner in suspected cases of criminal abortion. Any deposition made by the patient could only be taken as evidence if the patient fully appreciated that she was beyond hope of recovery.

HAEMOCHROMATOSIS AND BRONZED DIABETES.

A MEETING of the Royal Medico-Chirurgical Society of Glasgow was held on February 18th, when Professor ROBERT MUIR gave a lecture and microscopic demonstration on haemochromatosis and bronzed diabetes. He pointed out that the essential pathological feature was the deposit of iron containing pigment in great amount and in unusual positions, this resulting in haemochromatosis. Diabetes resulted only when the lesion in the pancreas was of sufficient degree, there being cirrhosis in this organ as well as in the liver. Two cases were described in which both bronzing of the skin and diabetes were present, and reference was made to the estimations of iron carried out with Professor Shaw Dunn in one of these. An account was given of two cases at an early stage of the affection, and from these the inference was drawn that the earliest lesions were cirrhosis of the liver and pancreas, with deposits of haemosiderin in these organs and in the retro-peritoneal lymphatic glands. In the pancreas the changes occurred at an earlier period in the secreting epithelium than in the islands of Langerhans, but the results did not warrant a conclusion as to the relation of the lesions in these structures to the onset of diabetes. The lecturer contrasted the deposits of pigment with those occurring from abnormal haemolysis, and pointed out that they differed both in amount and in distribution, those in haemochromatosis being much greater and occurring in sites, such as thyroid, heart muscle, skin and stomach, in which haemosiderin resulting from haemolysis did not occur. From these facts and from the fact that in haemochromatosis there was no evidence of increased blood destruction or regeneration, it was not justifiable to conclude that the iron pigment was actually derived from haemoglobin. There might be an inability to use up again the iron derived from normal haemolysis, but in this case the peculiar distribution of the pigment could not be explained. The essential factor in haemochromatosis appeared to be a special affinity of the tissues and organs for iron, and the source of the stored iron must ultimately be the iron in the food, but whether or not it passed through the form of haemoglobin was not certain. The cirrhosis of the liver, and possibly of the pancreas, seemed in some way to be related to this abnormal metabolism of iron, but there must be some special factor, as in most cases of cirrhosis of the liver the accumulation of pigment was absent. The accumulation of iron must go on for a long period of time, sometimes for two or three years, even if all the iron in the food were retained.

DIATHERMY FOR INOPERABLE GROWTHS.

A MEETING was held at Liverpool of the Liverpool Medical Institution, conjointly with the Manchester Medical Society, on March 3rd, with Dr. J. E. GEMMELL in the chair. Sir WILLIAM MILLIGAN read a paper on the treatment of inoperable malignant growths of the pharyngeal and epiglottic regions by means of diathermy and radio-diathermy. He pointed out the type of case suitable for diathermy treatment and described the

rationale of the treatment. In cases in which diathermy was done close to large blood vessels great care had to be taken, as otherwise there was a risk of sloughing of arterial walls and severe secondary haemorrhage. In many cases it was advisable to tie the main blood vessels leading to the affected regions. Diathermy treatment had the advantage of sterilizing the tissues, blocking the lymphatics and small blood vessels, and of readily destroying malignant cells owing to their having in all probability a lower vitality than normal cells. Where the growth to be treated was situated in the immediate neighbourhood of the larynx, it was advisable to perform a preliminary tracheotomy. In small growths the best results appeared to follow the use of a current of from 500 to 900 milliamperes, let in large growths 1 to 2 ampères were necessary. Where there was much necrotic tissue it was a good plan to perform a preliminary scraping, great care being taken, however, to avoid any bleeding as far as possible. The pain produced was, as a rule, not great until about the eighth or tenth day, when it was considerable owing to the separation of the slough and the formation of a raw granulating surface. The presence of glands did not negative diathermy operations, and glands might be treated either by diathermy itself or by intensive x-ray treatment. Where intensive x-ray treatment was used it was advisable to desensitize the skin either by the application of pressure or by the subcutaneous injection of salt solution.

The advantages of diathermy were:

1. It might be employed when ordinary surgical procedures were impracticable.
2. It did not produce much, if any, shock.
3. With reasonable care it was a bloodless procedure.
4. It had the merit of sterilizing the tissues, blocking vascular and lymphatic vessels, and preventing the dissemination of the cancer cell.
5. It frequently afforded relief from painful symptoms and mechanical difficulties in cases surgically hopeless.
6. Septic and bronchopneumonia were much less frequent than after cutting operations.

Its disadvantages were:

1. It destroyed both healthy and diseased tissues.
2. The walls of adjacent blood vessels might become softened and secondary haemorrhage result.
3. Where the skin was involved keloid cicatrices might result.

He referred to a series of inoperable surgical cases where by means of diathermy life has been prolonged for from two and a half to three years with complete comfort.

Variations of the Normal Stomach.

Dr. A. E. BARTLEY discussed the variations of the normal stomach. He maintained that the old anatomical pictures were caricatures, and that the distortions were due to the action of formalin or other preservatives, coupled with the effect of rigor mortis. Essentially the stomach was a living muscular tube whose very varied alterations in appearance were largely due to alterations in muscular tone. The tonic action was a function of the living muscle, and could only be studied in life by means of x-rays. The main function of this tonic action was to stabilize the stomach so that it maintained the contents in tubular form in spite of gravity. When tone relaxed the contents descended to the lowest part of the stomach. He demonstrated models of normal empty and full stomachs, and also a series indicating the way in which its shape was changed by the alteration of posture. Tonic action was responsible for the maintenance of the shape of the normal stomach, and he insisted that transitory loss of tone and gastroptosis were simply variations of the normal. He then dealt with the musculature, and laid stress on the great importance of the innermost layer, the incomplete and powerful band of oblique fibres passing down on either side of the lesser curvature, and illustrated the band by a series of dissections by Jefferson. He pointed out that in atony this oblique band was apparently unaffected, while the rest of the muscle was thinned out. In gastroptosis, on the other hand, the oblique fibres were elongated proportionately with the other coats.

Professor E. S. REYNOLDS mentioned some points arising in connexion with vascular lesions of the brain, quoting illustrative cases. He referred particularly to meningeal haemorrhage occurring during birth, to emboli and their results, and compared these in their symptoms and course

with thrombi and haemorrhage. He alluded to the difficulty which often occurred in diagnosing whether a hemiplegia was due to thrombus or haemorrhage, and the consequent difficulty in treatment.

Sir WILLIAM THORNBURN gave an account of cases of posterior rhizotomy and of drainage of the spinal theca. He related several personal cases in which the operation of rhizotomy had been performed for gastric crises, and analysed the published records. With regard to rhizotomy for pain, he indicated, again from personal cases, why in many instances relief was not to be anticipated, and why the results were less satisfactory than in gastric crises. He did not recommend Foerster's operation for spastic paraplegia. He then referred to cases resembling transverse myelitis, in which drainage of the theca spinalis was followed by rapid recovery. He recalled the earlier work of Horsley on so-called chronic spinal meningitis, and strongly urged the exploration of any doubtful cases of this type; in practised hands the operation of laminectomy was as safe and reliable as laparotomy.

THE CIRCULATION IN ACUTE INFECTION.

At a meeting of the London Association of the Medical Women's Federation held on March 8th, with Mrs. FLEMING, M.D., in the chair, Dr. ESTHER HARDING read a paper on the circulation during and after acute infection. She pointed out that this problem involved a discussion of the conditions not only of the heart and myocardium, but also of the blood vessels, the nervous mechanism—central or peripheral—controlling blood vessels, and of the blood, as all these divisions of the circulatory mechanism were affected, primarily or secondarily, in acute infections. Her data were gathered chiefly from a study of diphtheria and influenza, but probably similar effects could be demonstrated in many other diseases—for instance, acute rheumatism, typhoid fever, pneumonia, and cholera. Diphtheria was, she said, particularly suitable for studying circulatory changes, because in this disease they were well marked and the complications of pyrexia were practically absent. Observations on the specific gravity of the blood in toxæmic cases showed that the slight general oedema—so called "lymph-logging"—was accompanied by a definite increase in the specific gravity of the blood, due to the loss of part of the fluid content, which led to a decreased volume of the blood in circulation. This fact suggested that the circulatory failure of diphtheria might be, in part at least, due to a condition resembling the oligæmic phenomenon described by Yandell Henderson in cases of shock. Recognizable dilatation of the heart was rare in fever hospitals, probably because of the complete rest enjoined on the patient, but very rapid dilatation might occur whenever exertion had been allowed at too early a stage of convalescence. Quickening of the heart, related either to myocardial insufficiency or to low peripheral blood pressure, occurred during most fevers. Slowing of the heart was the rule in certain fevers—for instance, typhoid fever—and it was very frequent in severe diphtheria and was usually of very grave significance. Of abnormal rhythms curtailed diastole frequently accompanied increased rate, sinus arrhythmia tended to disappear as the heart quickened. Sir James Mackenzie taught that its reappearance might be taken as a sign of the return to normal, but Dr. Harding found an irregularity which she had taken to be sinus arrhythmia practically always present in cases of diphtheria with slowed heart rate. Sir James Mackenzie, to whom she submitted tracings of the condition, suggested however that the condition was not of true sinus type and might be peculiar to diphtheria.

The late effects of infection might be grouped under two headings: myocardial weakness, and weakness of peripheral circulation, which might or might not be vasomotor in origin. The differential diagnosis between the two types was important from the point of view of treatment. In both the patient complained of feeling slack, there was some breathlessness and palpitation, fatigue from mental exertion, and irritability; in both there was an excitable heart, shortened diastole and poor exercise response. In the myocardial group the patient was at his best in the morning after a night's rest, and got more and more tired as the day went on; in the peripheral weakness group the patient was tired in the early part of the day,

but improved with exercise. The myocardial group were breathless all the time and the breathlessness was of the anoxaemic type, with curtailed expiratory pause; the peripheral type were breathless only after exertion. For the first group prolonged rest was necessary, and bromides and digitalis were very useful; in the second type strychnine, cold baths, and adrenaline by the mouth first thing in the morning were often very helpful. It was important, also, in dealing with long-continued debility following acute infection not to forget the possibility of functional weakness dependent on a psychological cause.

Reviews.

DISEASES OF THROAT, NOSE AND EAR.

THE task of producing a textbook on *Diseases of the Throat, Nose and Ear*¹ within a volume of reasonable size has severely taxed the powers of Dr. DAN MCKENZIE, and had the author concentrated himself on one or other of these subjects we believe that he would have succeeded in writing a book of more permanent value. While Dr. McKenzie writes with a freshness of style and originality of thought which makes the book eminently readable, he shows rather too pronounced a tendency to break away from accepted teaching. This would no doubt be admirable and justifiable in a monograph on some special subject, but in a textbook it is apt to give the student somewhat one-sided views. References are not given, though numerous writers are quoted. The author, however, does not always show a correct sense of proportion in giving prominence to the opinions quoted; sometimes he attaches great weight to a minor point, while at others he seems scarcely to give credit where credit is due. As an instance of this neither Sluder nor Whillis and Pybus are mentioned in connexion with tonsillectomy. Much as he has undertaken within the precise limits of the title, the writer has gone still further and introduced material not strictly cognate. A striking example of this is the part dealing with diseases of the thyroid gland, which is introduced in the chapter on diseases of the trachea. The thyroid gland, of course, falls to some extent within the province of the laryngologist as well as of the general surgeon, and the writer rather deprecatingly begins his description with the words "Only those diseases of the thyroid gland will be touched upon which have particular bearing upon laryngology." Yet he touches upon almost all of them. Thus exophthalmic goitre is included, though it presents a problem of general medicine, and has no special connexion with laryngology, as malignant disease may have. The author has devoted much space to operative surgery; this is, on the whole, very helpful, and brings the subject well abreast of the times, though here and there a somewhat unexpected vein of pessimism shows itself. In the section on the ear there are certain statements regarding the intracranial complications of middle-ear disease which demand notice. The author states that in uncomplicated cases of lateral sinus thrombosis optic neuritis is absent. Presumably he means in cases in which lateral sinus thrombosis is the only complication, but in actual fact optic neuritis is not infrequent in such cases apart from other complications. Again, ligation of the jugular vein in every case is strongly advised by Dr. McKenzie. The indications, however, both for and against this procedure were laid down definitely by Ballance many years ago, and nothing has since been added. In dealing with abscesses of the brain, whether cerebral or cerebellar, the author advises a preliminary lumbar puncture; but this is a procedure which has been condemned by good authorities, since the sudden alteration in intracranial pressure may cause the abscess to burst. Finally, it is strange that a description of otosclerosis should contain no reference to the classical researches of Albert Gray, although other authorities are mentioned. The book affords a fair and comprehensive survey of the latest work in the subjects indicated; its value is to be found in its breadth of outlook, while such defects as we have ventured to indicate seem to arise from the author having attempted to cast his net too wide.

Such matters will readily lend themselves to correction in a future edition. Dr. McKenzie has made a valuable contribution to laryngology and otology by treating his subject in an unconventional manner; such a book has the merit of stimulating the reader to think for himself.

The fact that a third edition of Dr. ROSS HALL SKILLERN'S book on the *Accessory Sinuses of the Nose*² has already been called for is striking evidence of its popularity, for the previous editions were produced as recently as 1913 and 1916. We venture to say that the author has well merited the success his volume has achieved. In all essentials, both in form and material, the book is unaltered from the previous editions, but the opportunity has been taken of introducing such additional information as was derived from experience in the war. Amongst other things it is interesting to note that the author attributes the comparative rarity of wounds of the frontal sinus, in comparison to those of the antrum of Highmore, to the use of steel helmets. In this edition there is an account of Mosher's method of exenteration of the ethmoid capsule, illustrated by an excellent series of drawings. Another interesting, though minor, addition is a short account of the experiments of Caldera, which prove that inhaled medicaments reach the mucosa of the sinuses. These naturally did not appear in the first edition. The book remains and is likely long to remain not only the most exhaustive and accurate exposition of the subject, but also one to which it is natural to turn in any case of doubt or difficulty for sound and practical advice. In this respect, the manner in which the vexed question of the treatment of the diseases of the frontal sinuses is approached displays the care and judgement of the writer, and the advice given is a model of wisdom and good counsel. No laryngologist can afford to be without the help of this book, and the only criticism we have to offer which bears on it particularly as a work of reference is that it deserves a better index.

THE SYMPATHETIC AND THE ENDOCRINE GLANDS.

THE ninth volume in order and the eighth to appear of the thirty-two promised parts of the *Traité de pathologie médicale et de thérapeutique appliquée*, edited by Émile Sergent, Ribadeau-Dumas and Babonneix, is that on *Sympathique et glandes endocrines*, by LEBROUILLER, HAVRIER, CARRION and GUILLAUME.³ Although clearly it is impossible to study one apart from the other, the idea of combining the accounts of the sympathetic with those of the glands of internal secretion in the same volume is both novel and convenient. The endocrine glands are first dealt with, and then, in the remaining third of the volume, the sympathetic system is described by A. C. Guillaume, who devotes sixty pages to the anatomy and physiology, and by P. Havrier, who summarizes the pathological aspects. The concluding chapter, on the therapeutical uses of the endocrine glands, has been entrusted to Carrion, who points out that there does not appear to be any general contraindications to the administration of organic extracts, and that so long as they are given by the mouth the question of anaphylaxis may be neglected. But in the case of each therapeutic product there are, of course, points of importance that must be taken into consideration. Formerly, when disturbances of a single gland, such as the thyroid in myxoedema or the adrenals in Addison's disease, formed the guiding principle in our conception of endocrine disorders, the problems of etiology and treatment were comparatively simple; but now that the functional correlation and interdependence of the glands of internal secretion have been established by experimental, physiological, and anatomical research, the more difficult subject of the pluriglandular syndromes—a term introduced by Claude and Gougeot in 1907—must be faced. As the physiology and anatomy of the endocrine glands do not

¹ *Diseases of the Throat, Nose and Ear*. By Dan McKenzie, M.D., F.R.C.S.E. London: W. Heinemann (Medical Books), Ltd., 1920. (Roy. 8vo, pp. 651; 199 figures, 2 plates. 42s. net.)

² *The Cystic and Suppurative Diseases of the Accessory Sinuses of the Nose*. By R. H. Skillern, M.D. Third edition, thoroughly revised and enlarged. Philadelphia and London: J. B. Lippincott Co., 1920. (Med. 8vo, pp. 412; 217 figures, 5 plates. 30s. net.)

³ *Sympathique et glandes endocrines*. Par P. Lebrouillet, Havrier, Carrion, et Guillaume. Tome IX. *Traité de pathologie médicale et de thérapeutique appliquée* (É. Sergent, Ribadeau-Dumas et Babonneix). Paris: A. Maloine et Fils, Éditeurs, 1921. (Dem. 8vo, pp. 557; 31 figures. 18 fr.)

justify a classification of pluriglandular disorders, a clinical method has been adopted, and on these lines three main groups are described: (1) Primary change in one gland with secondary disorders in one or more—for example, Graves's disease with ovarian insufficiency and amenorrhoea; (2) the association of two uniglandular syndromes—for example, myxoedema with acromegaly; (3) the association of several uniglandular syndromes without well-marked predominance of any one. The most potent causes of pluriglandular syndromes are syphilis, whether congenital or acquired, and tuberculosis, and one of the commonest forms is that due to insufficiency of the thyroid, testis, and adrenal.

In his general introduction Lereboullet, referring to the treatment of pluriglandular syndromes, states that in some cases the extracts of the affected glands should be given successively, whereas in other instances they should be given simultaneously; but his favourite preparation is a cachet containing extracts of thyroid, pituitary, ovary, and adrenal, and he finds that thyroid extract is better borne when combined with adrenaline or pituitary extract than alone. The whole subject matter is clearly and attractively described, and we get a good picture of contemporary French opinion.

ANXIETY HYSTERIA.

THE unpretentious little volume on *Anxiety Hysteria*,⁴ of which Dr. C. H. L. RIXON and Dr. D. MATTHEW are conjointly the authors, is one which it is definitely a pleasure to read. Many books have been written on the war neuroses, but we do not recall one which would appear so exactly to meet the needs of the busy practitioner as this. The subject is presented in clear, precise, and non-technical language. The psychology is sound though elementary, and it suffices to give the practitioner an understanding of the symptoms which are peculiar to these nervous cases. The chapter on treatment is practical and detailed, and it is evident that the authors' views are based upon a wide experience. The therapeutic measure utilized more especially is that of "free association," but the use of the term psycho-analysis is avoided on grounds which appear to be sound. This term has now come to be regarded as implying adherence to a particular view as to the origin of the neuroses, and in its place "Mental Exploration" is employed as a term which does no more than describe the method of treatment adopted.

Colonel Sir A. Lisle Webb, Director-General of Medical Services, Ministry of Pensions, contributes a sympathetic foreword to this volume, and with his views as to its value to those who are brought into contact with the problems of functional nervous disorder we are in complete agreement.

THE PHYSICAL BASIS OF HEREDITY.

JUST as the publication of the *Origin of Species* gave an enormous impetus to research in comparative anatomy, so the experimental work of Grigor Mendel has created an army of workers who have turned their attention to the problems of heredity. The results of their investigations have yielded a vast output of literature. One of the most recent books, dealing in a more or less comprehensive manner with the results so far obtained, is that by Professor T. H. MORGAN of Columbia University, entitled *The Physical Basis of Heredity*.⁵ It is one of the series of monographs on experimental biology now being published in America.

The subject of heredity is one of the utmost importance not merely from the purely scientific point of view, but also from its bearings on the health and social conditions of the community. Mendel obtained his facts by the careful record of results of experimental breeding and crossing of plants. For some years past this line of attack has been, and is still being, carried on and extended. This further work has, in the main, confirmed Mendel's conclusions. It was soon found, however, that

breeding experiments alone, whether in plants or animals, afforded no explanation of the facts. Consequently, a solution of the problem was sought by cytological investigation. This has yielded many facts and much theory. Professor Morgan has attempted to give a summary of both in his book, and has added a bibliography which extends to twenty-seven pages, but is yet by no means exhaustive.

Cytologists regard the chromosomes as the important if not the sole carriers of hereditary characters. Recent cytological researches have taught us, however, much with regard to protoplasmic inclusions and a knowledge of their behaviour in cell division. These, together with observations on maternal inheritance, afford much room for speculation as to the part played by the cytoplasm, if any, in the transmission of characters from parent to offspring. Several chapters are devoted to a discussion of these problems and to the observed facts upon which it depends.

Plough's interesting and important experiments on the influence of temperature on chromosomal "crossing over" are recounted, and in the author's opinion can be adduced as evidence against the "reduplication theory" of Bateson and Punnett.

It is impossible in a short space to deal adequately with the many aspects of so wide a field as are dealt with in the volume under consideration. The author's general attitude towards the problems of inheritance is set forth in the introduction, and he there states that one of the objects he had in view in writing the book was to show that objections to "particulate inheritance" have no real foundations in fact. Nevertheless, however intimate may be our knowledge as to the behaviour of the chromosomes during resting and mitotic phases, a perusal of the book shows that we are still a very long way from understanding the causation of such behaviour. The field for speculation seems almost illimitable.

Professor Morgan's work in this and in other fields is well known and appreciated by all biologists. Any book of which he is the author is sure to arouse interest. In this instance he has succeeded in placing before us a good account of the present position of the subject. He may well be congratulated on the result. It is "stiff reading," but the subject matter requires "stiff thinking."

THORPE'S DICTIONARY OF APPLIED CHEMISTRY.

THE interval between the publication of the last edition of Sir EDWARD THORPE'S *Dictionary of Applied Chemistry*⁶ and its immediate predecessor was twenty-two years. In the preface to the new edition, the first volume of which was published a few weeks ago, the editor considers it necessary to apologize for the fact that, owing to circumstances arising out of the war, it has not appeared earlier; yet the interval on this occasion is only nine years. We have heard much of the influence of applied chemistry on the operations of the war, but Sir Edward Thorpe maintains that it is equally true that the war exercised a great influence on applied chemistry, both in this country and abroad, leading to an enormous expansion, more or less permanent, of certain branches. New products have been made, new processes devised, and established methods improved and extended. The progress of manufacturing chemistry in this country and in other English-speaking countries has, he believes, been permanently affected for good. The entire work has been carefully revised, and for this purpose many new contributors have been found. The new edition, however, has one disadvantage—that it has been found necessary to increase the size. The last edition contained five volumes, its predecessor three; the new edition will contain at least six, possibly seven.

The first volume of the new edition carries the matter from A to C, the last article being a lengthy account of the uses of calcium and its salts. The article on alkaloïds is contributed jointly by Dr. George Barger, F.R.S., Professor of Chemistry in relation to Medicine in the University of Edinburgh, and Dr. F. L. Pyman, Professor of Technological Chemistry in the University of Manchester. Professor Barger has also written articles on several drugs,

⁴ *Anxiety Hysteria. Modern Views on some Neuroses.* By C. H. L. RIXON, M.D., M.R.C.S., and D. MATTHEW, M.C., M.B., Ch.B.; with a foreword by Colonel Sir A. Lisle Webb, K.C.B.E., C.B., C.M.G. London: H. K. Lewis and Co., Ltd. 1920. (Crown 8vo, pp. 136; 8 illustrations; 4s. 6d. net.)

⁵ *Physical Basis of Heredity.* By Thomas Hunt Morgan, Professor of Experimental Biology in Columbia University, Philadelphia and London: J. B. Lippincott Company. 1920. (Demy 8vo, pp. 305; 117 figures, 10s. 6d. net.)

⁶ *A Dictionary of Applied Chemistry.* By Sir Edward Thorpe, C.B.E., F.R.S., assisted by eminent contributors. Vol. i. Revised and enlarged edition. London and New York: Longmans, Green and Co. 1921. (Med. 8vo, pp. 752+x; illustrated. 60s. net.)

including that on aconitine and the aconite alkaloids, and on adrenaline. The latter contains an account of the physiological methods of estimating the substance and a list of substitutes. Professor Halliburton again contributes the articles on bile, blood, and bone. It has not been found necessary to make any considerable alterations in the article on bread, but it is noted that under war conditions arrangements were made in Germany to collect the germ of wheat from the mills and extract the 10 to 12 per cent. of oil which it contains, with the intention of using it for the production of margarine. The longest article in this volume is that on analysis, the first part written by Professor G. T. Morgan, of Birmingham, and the second, on electro-chemical analysis, by Dr. F. Mollwo Perkin.

Thorpe's *Dictionary* has long been an indispensable part of laboratory libraries, whether those of research institutes or of manufactories, and the new edition, judging by the first volume, will fully maintain its high reputation.

NOTES ON BOOKS.

MENTAL nurses will find in *Model Answers to Questions on Nursing*,⁷ by Mr. HECTOR MACPHAIL, a book which should prove of real assistance to them in preparing for their examinations. Many nurses with a good knowledge of their work have had little experience in putting their ideas on paper, and for such, a book of this kind is almost a necessity. Its answers contain a large amount of useful information which will serve to supplement and to express in a somewhat different form the contents of the ordinary nursing manuals. The answers are brief and to the point, and altogether as many as 240 questions are dealt with. The regulations for the nursing certificate of the Medico-Psychological Association have recently been altered, and, no doubt, Mr. Macphail will note this in any subsequent editions of his book. We observe in one question that manic-depressive insanity is spelt *manic-depressive*. We fear it is not a misprint and suspect that some examiner must be blamed for this rather than Mr. Macphail himself.

Dr. C. B. BURR, an American psychiatrist, has revised his book entitled *Practical Psychology and Psychiatry*,⁸ the fifth edition of which has recently been published. It is written for the use of nurses and attendants who are taking a course in mental nursing. Both the theoretical and practical parts are clearly written, but we are of the opinion that the chapter on "Symbolism in sanity and insanity" is most unsuitable in a textbook designed for mental nurses. It is almost incredible that these crudely sexual details and vulgarisms should be recounted for the instruction of young, immature, and often poorly educated girls, and it is most difficult to find any possible value to nurses in the information thus conveyed.

Sarah Battle, who is still something of an authority, held that in square games (she meant whist) "all that is possible to be attained in card games is accomplished." At any rate, if for whist we substitute its grandchild, Royal Auction Bridge, a great many doctors will be found to endorse Mrs. Battle's opinion. It needed little observation during the war to discover the popularity of auction among members of the medical profession. In every officers' mess it beguiled the tedium of inactive times, at home and abroad; it was played in sun-scorched tents, and in waterlogged dug-outs by the light of candles that flickered with each bursting shell; and the medical officers who served afloat found it a solace on every one of the seven seas. We may therefore be excused for noticing very briefly two little treatises on this game of cards that have been sent to us for review. The more important of the two is perhaps the new edition of *Royal Auction Bridge*⁹ by the well known writer "Bascule," who now includes a chapter on Contract Bridge for those who agree with him that that is "the game of the future." In other respects it differs little from the first edition, which went through many impressions. The other work is a second edition of Colonel HINGLEY'S *Hints on Royal Auction Bridge*.¹⁰ This, in a conversational way, sets out to guide the player

through some of the difficulties of declaring a suit and playing a hand. The author's method of instruction may be found helpful: "The truth is, a fearful lot of rubbish is written about bridge; the subject is very soon exhausted, and all any author can do is to point out some rules for guidance, nothing more. Some people prefer the very safe game, and some the forward game." In fact, the game of bridge is very like the game of life, save that it has rules framed by the Card Committee of the Portland Club, with the co-operation of a representative of each of five other clubs.

Medical chess players, of whom we believe there are a good number, may be glad to know of a little book, *The Pocket Guide to the Chess Openings*,¹¹ by Messrs. GRIFFITH and WHITE, the joint authors of a more comprehensive work on the same subject. Here will be found a selection of openings illustrating methods of play in the early stages of the game, drawn mainly from the practice of masters of to-day. For the guidance of less experienced players a summary is given of the laws of chess, together with a short definition of terms, a statement of the relative value of pieces, an introductory chapter on general principles in tactics and strategy, and a page of useful maxims which the beginner might well commit to memory.

¹¹ *The Pocket Guide to the Chess Openings*. By R. C. Griffith and J. H. White. London: G. Bell and Son, Limited. 1920. (3½ × 6½; pp. 116. 3s. 6d. net.)

APPLIANCES AND PREPARATIONS.

A Standardized Reverdin Needle and Holder.

MR. VICTOR BONNEY (London, W.) writes: A drawback to all the present patterns of Reverdin's needle is that, as the needle is attached to the holder by a square fitment, it is impossible to standardize them so that any needle will fit any holder of the same type. This objection applies even to the otherwise ideal pattern designed by my late assistant, Mr. Arthur Woo. The Genito-urinary Company have therefore constructed for me a new pattern similar to the Woo pattern, but having a round fitment, so that every needle fits the holder without special adjustment, and when new ones are required it is not necessary to send the holder back to the makers to fit them. This is a great improvement, especially for surgeons living in the country or abroad. The round fitment, moreover, has this further advantage that it allows of the needle being moved in the holder into any position the surgeon desires, so that, for instance, he can adjust it for passing it "back-handed" if he wishes to. The needle is held in the holder by a "locking lever," as in the Woo pattern, rendering changing of the needle a matter of a few seconds. The holder and needle can be obtained not only from the Genito-urinary Company who make it, but from Messrs. Allen and Hanburys as well.

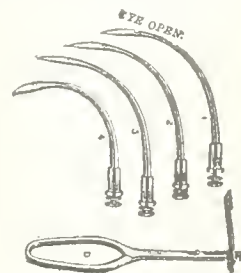

Portable Manometer for Intrapericardial Pressure.

Dr. G. ARBOUR STEPHENS (Swansea) has devised a portable manometer for estimating the intrapericardial pressure *post mortem*. He finds it useful as a ready test (even without opening the chest) of heart failure as a cause of death, for in all such cases the fluid does not move in the glass tube—that is, the intrapericardial pressure is atmospheric, whereas when the heart is normal the fluid is drawn up towards the bent top, T, of the tube to which the rubber tube is attached that is, there is a suction action due to the negative intrapericardial pressure which in health keeps the lubricating pericardial fluid at an equal thickness all round the heart. This fluid tends to vary in quantity and quality, and this variation has a marked effect on the movements of the heart. When the heart beats rapidly as the result of exercise, there is an increase of the area of cardiac dullness, due, in his opinion, to an increased secretion of the pericardial fluid necessary for lubricating the more rapidly moving organ, and the distress experienced before second-wind is established is, he thinks, due to the process of producing the right amount of that lubrication. In those cases in which objection is raised to a *post-mortem* examination the aspirating needle, N, can be inserted at the inner end of the fourth left intercostal space, and passed directly downwards towards the heart and through the anterior portion of the pericardium.

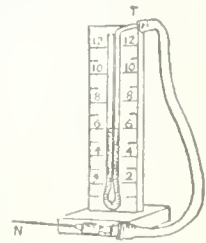

⁷ *Model Answers to Questions on Nursing set by the Medico-Psychological Association*, by Hector Macphail. Third edition. London: The Scientific Press, Ltd. 1920. (Cr. 8vo, pp. xv+240. 6s. net.)

⁸ *Practical Psychology and Psychiatry*. By C. B. Burr, M.D. Fifth edition. Philadelphia: F. A. Davis Company, 1921. (Post 8vo, pp. 269; 11 illustrations. 2 dols. net.)

⁹ *Royal Auction Bridge*. By "Bascule." New edition. London and New York: Longmans, Green and Co. 1920. (Fcap. 8vo, pp. 210. 5s. net.)

¹⁰ *Hints on Royal Auction Bridge*. By Lieut.-Colonel S. H. Hingley. Second edition, revised and enlarged. London: G. Bell and Sons. 1920. (Fcap. 8vo, pp. 116. 3s. 6d. net.)

THERAPEUTIC TENDENCIES.*

BY

CHARLES WINTBY, M.D.,

BATH.

IN an old book given to me by a patient, *Culpeper's Last Legacy*, the sixth edition, dated 1630, that famous seventeenth-century practitioner has set forth his "Choicest Secrets" for the benefit of posterity. For the most part it is an olla podrida of prescriptions for ailments of every kind culled from various authorities, many of an outrageous, disgusting or obviously superstitious nature, and some frankly ludicrous. One of Culpeper's remedies for epistaxis is to "put a piece of hot hog's turd as it comes from the hog up the nose!" Another, derived from Mizaldus, is to writhe *consummatum est* on the patient's forehead with his own blood. "If any be troubled with stomach worms," observes our good Nicholas, "let him hold a piece of a honey-comb in his mouth, and the worms will come out to the honey."

Still, Nicholas was no quack; no fool, either. Many of his suggestions are quite sound. He was, of course, a famous herbalist; he was also an anatomist, who made his own animal dissections, and had no scruples about giving Galen the lie direct when he found his descriptions inaccurate. In this last book, having previously dealt with simples on the same lines, he devoted several chapters to a synopsis of the compound remedies in general use in his day—and some of them are still far from obsolete—in which these are methodically tabulated according to their supposed general or local effects.

At no period has the practice of medicine been wholly empirical; and it certainly was not so in Culpeper's time. Among the great array of his remedies, genuine or supposititious, no choice could be made without guiding principles of some sort. We find these clearly indicated in Part III of his *Last Legacy*, entitled "Aphorisms." From this it appears that all medicines may be classified as heating, cooling, drying or moistening in effect; and that each of these qualities may be subdivided into four degrees. For example, a fluid which by outward application caused burns or blisters would be called heating in the fourth degree, and as such unfit for internal administration. Pathological conditions are similarly classified as hot, cold, dry or moist; and the general principle seems to have been that the kind and degree of pathological deviation, local or general, was a guide to the appropriate remedy. Thus, a condition of heat and dryness of the second degree would indicate a remedy cooling and moistening in the same degree. A moist remedy would be one which caused a flux of any kind—a purgative, diuretic or diaphoretic; a dry one would be a local or general astringent.

In addition to this primary classification, remedies are grouped in accordance with their topical affinities—what we should call their organotropisms. Part IV of the *Last Legacy* is devoted to aphorisms intended to guide the physician in the choice of drugs adapted to particular organs—for example, "cephalicks," "pectorals," "cordials" (that is, cardiac remedies), "renals," "hystericals" (that is, uterine agents), and so forth. Culpeper attached some importance to odour as a guide to remedies, particularly for those classified as "cephalicks," most of which are of a pleasant and aromatic or else of a decidedly nauseous odour. He thought that there was a special relation between the brain and the uterus, the joints and the stomach, so that all are similarly affected by the same drugs. He attached some importance to the doctrine of "signatures," that "yellow purges cholera, black melancholy, white flegm," and so forth. He was also a professed astrologer, who was careful to gather his herbs under favourable aspects. But his mysticism is tempered by common sense, just as his inert or crude drugs are prescribed with suitable adjuvants or correctives. Such, then, in brief outline, were Culpeper's guiding lights. It will be interesting to compare with them those which underlie distinctively modern methods.

Of these, let us consider first the group of remedies comprised under the term vaccine therapy, a method rescued from empiricism by Pasteur's epoch-making discovery of

the rôle of the yeast plant in fermentation, and Davaine's identification of the anthrax bacillus. Like all great discoveries, this was but the bringing into clear light of a principle already adumbrated in the consciousness of mankind. The practice of inoculation for small-pox was begun in the early part of the eighteenth century, the famous Lady Mary Wortley Montagu having played a pioneer part in its popularization. When, in 1798, Edward Jenner, after twenty-five years' research, published his *Inquiry into the Causes and Effects of the Variolae Vaccinae*, the cruder form of prophylaxis was for some of his medical opponents a lucrative speciality. Jenner himself was led to investigate the subject by his frequent failure to inoculate with small-pox those of his country patients who had suffered from "cow-pox," and the discovery of a vague opinion among dairy folk that this was a preventive. It is the great principle of attenuation which is the foundation stone of vaccine therapy; and this stone was laid by Edward Jenner. I have searched Culpeper's book in vain for any evidence of awareness among seventeenth-century practitioners of the true nature of infection. In a section devoted to the pestilence, he goes out of his way to combat the exaggerated terror of the disease, which in his day too often deprived sufferers of the services, not only of their neighbours, but even of a physician. He himself attributed the disease to a corrupted and unwholesome air caused by a malign conjunction of the superior planets. It is interesting, however, to find among Culpeper's prescriptions one recommending drachm doses of the desiccated and pulverized liver of a rabid dog as a remedy for the bite of such a dog. Also, there seems to be an anticipation of modern surgery in the strong recommendation of a linen cloth soaked in lime-water, prepared by pouring boiling water on quicklime in a clean new earthen vessel, as a dressing for wounds and ulcers. "This water," says Culpeper, "draws out the corruption of putrid sores. Mizaldus extols it to the skies."

The Jennerian method—that is to say, the introduction of pathogenic organisms in a living although attenuated state into the circulation—is not, of course, obsolete, but is, I think, in a fair way to become so. The awkward consequences that sometimes follow vaccination are, no doubt, in the majority of cases due to septic complications, but there must always be an element of uncertainty as to the behaviour of a living virus when introduced into a human organism. The modern tendency in vaccine therapy—a tendency accelerated, if not initiated, by the researches of Ehrlich and Almroth Wright—is to transform a biological and empirical into a chemical and truly rational method. These two distinguished men have approached the problem of the treatment of infective maladies the one from the chemical, the other from the biological point of view. Ehrlich's famous side-chain theory was an extension to the biological sphere of a hypothesis derived from the study of complex organic molecules, and was utilized by its inventor in an attempt to evolve an improved method of chemical treatment. Wright's opsonin theory was based on observation of the phenomena of infective and counter-infective processes, and is the basis of modern vaccine therapy. Yet the common aim of both investigations tends to a similar goal. In his recent investigations Wright has been drawn to inquire into the possibility of immunization *in vitro*, and deems it possible, "not only to test the efficiency of vaccines on normal blood *in vitro*, but also to determine upon the patient's blood *in vitro* what vaccine and what dose of that vaccine would give the desired effect." This clearly would be a close approximation to the ideal pharmacological method, especially in view of the fact that vaccines tend to conform to the chemical type of remedy, as isolated toxins of presumably definite and ascertainable composition. The term chemio-therapy calls to mind Ehrlich's epoch-making discovery of salvarsan (dioxidiamidarsenobenzol dichlorhydrate), but the objective of his *therapia sterilisans* is, of course, achieved in a different way. With vaccines it is always an active immunity, due to exploitation of the latent phylactic resources of the patient, that is aimed at. Salvarsan is, by reason of its direct attack upon the spirochaete, comparable to an antibacterial serum, such, for example, as Yersin's bactericidal plague serum. This fact constitutes at once the strength and weakness of the method: on the one hand, the benefit is prompt and independent of the constitutional response of the patient; on the other hand, it is a merely quantitative effect, the

* Read before the Clinical Society of Bath on December 3rd, 1920.

number of spirochaetes rendered *hors de combat* is necessarily limited by the amount of "606" that can be brought to bear on them. The defensive process initiated or augmented by a vaccine bears no necessary proportion to the dose introduced; the effect is, it seems to me, qualitative rather than quantitative. On the other hand, as Wright himself admits, vaccine therapy is permissible only when the body is not already making its maximum immunizing response, and is also generally unsuccessful in presence of pyrexia and severe constitutional disturbances, unopened abscesses, and foul, discharging or sloughing wounds. It gives less favourable results in long-standing than recent infections. As between the direct attack of antibacterial or antitoxic serums upon the pathogenic organism or its toxins and the evocative action of vaccines the present therapeutic tendency is decidedly favourable to the latter method—that of active in preference to passive immunization.

It is an interesting, albeit somewhat speculative, question to ask how our views of drug therapy in general are being or are likely to be modified by the dominant conception of immunity. To some extent one can recognize a similar duality in the use of drugs to that involved in the distinction between vaccines and serums, active and passive immunity. "The whole ground of Physic," says Culpeper, "is comprehended in these two words, *Sympathy* and *Antipathy*; the one cures by strengthening the part of the body afflicted, the other by resisting the malady afflicting." Here, surely, are foreshadowed the two points of view which were later to split the profession into conflicting schools of thought. There is, however, nothing really incompatible in these two points of view: belief in the efficacy of Behring's serum does not preclude faith in that of anti-enteric vaccine. In a lecture delivered last year Sir Almoth Wright described experiments proving that "in response to inoculations of a staphylococcal vaccine the blood serum and lymph acquire bactericidal powers for both staphylococci and streptococci." In fact, it would seem that immunity is not, as has hitherto been thought, merely specific; inoculation may produce collateral as well as direct immunity. This conclusion suggests the questions whether something comparable to immunity be attainable by ordinary drugs, and whether the leaning towards vaccines rather than antitoxins—towards what Culpeper calls the method of "sympathy," of "strengthening the part afflicted"—be discernible in the wider field of modern medicine.

If, as can scarcely be questioned, the legitimate resources of drug therapy include the administration for curative purposes in medicinal doses of remedies capable of producing symptoms resembling those of the malady under treatment, it seems that the conditions of success must be approximately the same as those experimentally established in and for vaccine therapy. Such a method might appropriately be termed *synergic*, in distinction from the more widely applicable *corrective* medication, of which, say, the administration of a purge on general principles, of a dose of sulphonal or barbitone for insomnia, or of a combination of alkalis for acidosis, are examples. I have more than once observed symptoms suggestive of anapylactic shock in endeavouring to push remedies like arsenic, and I am inclined to think that much better results might be obtained in drug treatment, and particularly with definitely organotropic remedies, by a modification of dosage and periodicity based on the assumption of the occurrence of a "negative phase" or period of diminished therapeutic susceptibility. It surely savours of crudity to jump straight to our maximum dose of such potent remedies as digitalis, nux vomica or strophanthus, and to give these for weeks together at intervals of three or four hours only, although when we push digitalis to clear up a dropsy we are after all using it correctively, not curatively.

Assuming that impaired nutrition is basic in most diseases, my suggestion is that a drug capable of acting as a physiological stimulus to a given organ will in smaller doses act as a *trophic* stimulus, and that such stimuli, if maintained long enough and never exceeded, will in some cases re-establish the normal nutrition and, consequently, the normal function. Further, that the maximum trophic effect will be produced by a dose just short of that productive of an appreciable physiological effect. This dose must not be regarded as a fixed quantity; as soon as tolerance of the original dose is established it should be

cautiously increased. As regards the spacing of doses no fixed rule can be laid down, but it should be long enough to preclude such heaping up of the trophic effect as would result in functional stimulation. Thus the medicine may be given night and morning, or, in some cases, once daily or less. The common observation that a remedy continued too long "loses its effect," the facts of drug and tobacco tolerance, and the enormous quantity of alcohol that some people can take with apparent impunity, all suggest that the principle of immunity has wider application than is yet commonly realized.

A closely related subject is that of toxic idiopathies, particularly those which manifest themselves in the form of coryza and bronchial asthma. Dr. John Freeman in a recent lecture showed that abnormal sensitivity to foreign proteins, such as grass pollens and animal emanations—for example, from the horse, cow, or, above all, the cat—can be detected by the production of conjunctival or cuti-reactions. In bronchial asthma, which he regards as the result of the endotoxin of the microbe causing the bronchitis, the skin reaction can be produced by using a solution of this microbe. Food idiosyncrasies can be tested for in the same way. Hypersensitiveness to foreign proteins is, he finds, commonly a family trait, but is apt to take diverse forms in its different members. I have myself often noted the occurrence of a liability to hay fever, asthma, or urticaria in members of the same family, and sometimes alternating in the same person. With regard to food idiosyncrasies, Dr. Freeman suggests that where mothers insist on faddy children finishing up their meals they are probably immunizing them against slight hypersensitiveness of this kind. In this, as in many other respects, modern mothers might with advantage revert to the sturdier methods of their Victorian forebears.

The department of modern medicine, comprised under the terms organotherapy, opotherapy, or endocrinology, may, I think, best be characterized as a realm of great expectations. We hope much of it, but, except in the treatment of such rare diseases as myxoedema, mongolism, or scleroderma, it is difficult to point to notable achievements. Although regarded as a distinctively modern method, its origin is deeply rooted in antiquity. "Dry a Bullock's, Sheep's, or Goat's bladder," writes Culpeper, "and beat it into powder, and give a drachm of it in water, vinegar, or any convenient liquor to such as cannot hold their water or use to piss abed and it will help them." In another section he affirms that the internal skin of a hen's gizzard "helpeth concoction"—that is, digestion—exceedingly; "nothing like it" if given after meals. Also he asserts that "the Brains of a Weazel dried and drunk in vinegar cures the Falling sickness." In a recent paper on the nervous system and the endocrine glands, Dr. Sybil Welsh suggests that below the level of the most simple type of nervous stimulus there is a set of systems of chemical control, aiding the co-ordination of the processes of nutrition, growth, and reproduction. In spite of the valuable work of Blair Bell and others, our knowledge of the mutual dependencies and reciprocal actions of the endocrine glands, and even of their individual effects, is still inadequate for confident generalization as to their therapeutic rôles. We are as yet mainly confined to the phase of empirical gleaning. The available secretions may be used in one of six ways: (1) diagnostically, to determine whether symptoms be due to excess or deficiency; (2) to compensate for a deficiency; (3) homo-stimulatively; (4) hetero-stimulatively—for example, in giving thyroid to promote ovarian secretion; (5) to inhibit excessive activity, as in the use of mammary extract to diminish ovarian activity; and (6) physiologically and occasionally, as in the use of adrenaline as a haemostatic or pituitrin to facilitate parturition. Of these six methods, by far the commonest and, so far, the most successful, are the second, of which thyroid feeding is a familiar example, and the last. It is in the exploitation of the homo- and hetero-stimulative and also of the inhibitory potentialities of endocrine remedies that the lack of adequate guidance is at present most evident. The treatment by pituitrin injections of uterine inertia, previously the commonest of indications for forceps delivery, is in my opinion the greatest advance made in obstetric practice for the past quarter of a century. I have been favourably impressed by the effects of parathyroid extract in cases of epilepsy. In one case of twenty-five years' standing the patient has been able to discontinue entirely the large doses of bromide she had been

taking for many years, and the seizures, although not entirely checked, are milder and followed by less mental disturbance. This drug is worth trying also in paralysis agitans, chorea, and the tremor of "shell-shock." Thyroid gland extract is indicated in cases of rachitis and infantile marasmus, and is said to have cured some cases of carcinoma. Pineal gland is recommended for children of backward mentality, also for premature mental failure. Cases of genital infantilism in girls and young women are benefited by ovarian feeding, also some cases of hysteria and painful menstruation. Extracts of the corpora lutea are said to alleviate the psycho-neurosis of the natural or artificial menopause, and of pregnancy, and to diminish the risk of abortion. Mammary gland extract is indicated in those forms of menorrhagia, metrorrhagia and hysteria which are attributable to excessive activity of the ovaries, and will sometimes check the growth of uterine fibromyomata.

One frequently sees cases in which girls and women show considerable enlargement of the thyroid gland without any of the recognized symptoms of cretinism on the one hand or of Graves's disease on the other. Whatever the explanation, such patients are often benefited by the cautious administration of thyroid extract. Some years ago Maranon published the observation that in 87 per cent. of cases of hyperthyroidism slight friction of the skin of the neck, near or over the gland, readily produces an erythema, sometimes accompanied by swelling. If this test be reliable, hyperthyroidism is the exception in the numerous cases of thyroid enlargement I have seen recently. It may well be that perverted rather than merely excessive or decreased activity is the commonest concomitant of such enlargement.

To sum up, it may be said that, while the note of mastery which distinguishes modern surgery is still to seek in medicine, there are signs of a growing intimacy of touch and sureness of method. The prognosis is good.

VOLUNTARY HOSPITAL FINANCE.

INTERIM REPORT OF THE MINISTRY OF HEALTH COMMITTEE.

The Committee appointed by the Minister of Health on January 25th, under the chairmanship of Viscount Cave, "to consider the present financial position of voluntary hospitals, and to make recommendations as to any action which should be taken to assist them," has made an interim report dated March 9th.

CONTRIBUTIONS BY APPROVED SOCIETIES.

The Committee states that the evidence already received has convinced it "that it is desirable, in the public interest, to maintain the voluntary system of hospital management, and also that—mainly owing to the large increase during and since the war of salaries and wages and the cost of provisions and materials—many of the hospitals are faced with a serious deficiency of income to meet necessary expenditure." The Committee intends in due course to make further recommendations, but its interim report is issued in order to deal with a pressing matter—namely, the propriety of the approved societies making contributions. The following is the text of the paragraphs dealing with this matter:

We understand that the quinquennial valuation of approved societies under the National Health Insurance Acts, which is now in hand, shows a considerable surplus over the amounts required for the purposes of the Acts. Excluding Ireland, the valuation of 4,926 societies and branches, containing 2,558,123 members (out of a total of approximately 10,000 societies and branches containing nearly 15,000,000 members), which had been completed on December 24th last, showed a total disposable surplus as at December 31st, 1918, of £2,171,576; and it is anticipated that when the valuation is completed the total disposable surplus of all the approved societies will not be less than £7,000,000. This result is attributed to a material extent to conditions arising out of the war, such as the reduction, owing to war conditions, of sickness, disablement, and maternity claims, and the release of reserves in respect of members killed on active service.

Under the provisions of the Acts the societies are empowered to submit to the Minister of Health for approval schemes for utilizing the disposable surplus in providing additional benefits during the next five years; and the list of additional benefits authorized by the Acts and

the Regulations made thereunder includes, besides such matters as increase of sickness, disablement, and maternity benefits, and the provision of dental treatment, the "payment of the whole or any part of the cost of the maintenance and treatment of members in a hospital or convalescent home."

We are strongly of opinion that, in the interests both of the hospitals and of the societies, the schemes to be approved should provide for the application of a substantial part of the disposable surplus in providing a contribution towards the cost of the maintenance of members in hospitals. It will not, we think, be denied that the work of the voluntary hospitals is of great value to the approved societies and their members. Of the patients treated at the hospitals a considerable portion, about 30 per cent. of the out-patients and a larger percentage of the in-patients, are insured persons, and the effect of hospital treatment is not only to relieve these patients from suffering, but also to reduce the periods during which they are a charge upon the insurance funds. The fact that while depleting the hospital funds the war has had the effect of greatly increasing the surplus available to the approved societies, seems to provide a special reason for the consideration by the societies of the claims of the hospitals. The power given to the societies by Section 21 of the 1911 Act to subscribe to hospitals has been little used, doubtless owing to the anxiety of those concerned in the management of societies that their resources shall be sufficient to meet all claims; but now that a surplus is in sight it seems probable that a different view will be taken.

The method which should be adopted in order to secure the above result requires some consideration. The contribution of an approved society might take the form either of a weekly payment towards the cost of the maintenance of any member of the society who might become an in-patient in a voluntary hospital, or of a quarterly or yearly subscription for the benefit of the hospital or hospitals concerned; but in the latter case some amendment of the regulations would appear to be required. In either case an arrangement might (if so desired) be made with the hospitals for relieving the members of the society from any obligation to make further payments in respect of their maintenance or treatment.

We have reason to believe that some of the largest approved societies would be glad to see these proposals generally accepted, and that the hospitals would welcome such a result.

We are aware that it is not the desire of the Ministry of Health to interfere unnecessarily with the schemes submitted by the different societies for the utilization of their surplus funds. But we are confident that if the proposals here made were brought to the notice of the members the general feeling would be in favour of providing this measure of assistance to the hospitals, and so of making some return for the great benefits which those institutions have so long and so generously conferred upon them.

We therefore recommend that the Ministry

- (1) should make any necessary amendment in the regulation;
- (2) should forthwith bring this matter to the notice of the societies concerned and advise them as to the amount of the contributions which might reasonably be made out of the available surplus; and
- (3) should not approve any scheme for the disposal of a surplus until the suggestion has received due consideration.

We should have preferred to include these recommendations in our general report, so that their relation to other parts of the report might be seen; but we understand that the matter is urgent, as some of the societies are now engaged in framing schemes under the Act.

The report is signed by all the members of the Committee—Viscount Cave, the Marquis of Linlithgow, Sir Clarendon Hyde, Sir W. B. Peat, Mr. Vernon Hartshorn, M.P., and Mr. R. C. Norman.

A SMALL epidemic of small-pox has recently occurred at Chicago, being apparently due to a case being mistaken for varicella. Up to December 116 cases had been notified.

The second International Congress of Eugenics will be held in New York from September 22nd to 28th. Further information can be obtained from the Secretary, Dr. C. Little, American Museum of Natural History, 77th Street, New York City.

THE mortality from tuberculosis in Austria has considerably increased during the last few years. Before the war it was on the decline, the number of deaths from this cause in Vienna among women being 2,635 in 1914. During the war this figure began to increase, and is now 5,018. The mortality is highest between 35 and 65.

British Medical Journal.

SATURDAY, MARCH 26TH, 1921.

MUNICIPAL MEDICINE.

It is generally recognized that the extension of plans for the municipal treatment of certain classes of patient and certain kinds of disease is a matter of serious moment to the private practitioner. We have seen the institution of medical inspection of school children, then of a tuberculosis medical service, followed by maternity and child welfare centres, and recently by venereal disease clinics. Still more recently proposals for the establishment of municipal hospitals, some of which have been carried out, have afforded further evidence of the trend of municipal enterprise and have convinced the general profession of the need of watching developments very closely.

All these matters have for some time past been under the consideration of various committees of the British Medical Association, and on March 16th a conference of these committees was held in order that the present situation might be discussed from all points of view. The conference was by invitation attended by some representatives of the medical officers of health. The hope that in this way some basis of understanding might be reached was not disappointed, and the conference at an early stage affirmed its desire to find some means of reconciling the difference between medical officers employed in municipal clinics and municipal hospitals on the one hand, and private practitioners in certain areas on the other. After this gratifying exhibition of professional solidarity the conference proceeded to the discussion of details, but though it sat for some four hours, it did not reach the hospital question. With regard to clinics, however, the ground was to some extent cleared. The desire of the representatives of clinical medicine in the committees of the British Medical Association was that the clinical work of clinics should be carried out by private practitioners. Many, perhaps the majority of medical officers of health, have preferred that clinics should be conducted by whole-time officers, who will be more directly under their personal control; and municipalities have been moved to take the same view on the ground of economy, since they believe that the whole-time officer would not cost so much as a rota of practitioners. A resolution, however, was adopted at the conference, moved by a member of the staff of a voluntary hospital, and seconded by the medical officer of health of a large urban district, to the effect that clinical work done for a public health authority should, wherever possible, be carried out through the agency of private practitioners, subject to conditions to be agreed upon.

The remainder of the time of the conference was mainly given to a discussion with regard to the medical inspection of school children. It was agreed that the wise and proper course for a local authority to take was to invite local practitioners to submit a scheme for giving advice and treatment at school clinics and also at maternity and infant welfare centres; it was agreed also that specialist treatment in such clinics should be given by part-time specialists. Both these recommendations were qualified by the phrase

"if possible." It is, of course, plain that the method is possible: it is followed in some other countries; the chief objection to it in this country would appear to be the risk of some extra expenditure. A further principle agreed upon was that those responsible for medical inspection ought not to refer a case to the clinic direct should the patient have a private practitioner or be willing to consult one. On the other hand, it was agreed that practitioners of the area ought to have the right themselves to refer cases to the school medical officer for treatment.

The near resemblance that may be traced between the recommendations of the Medical Consultative Council of the Ministry of Health with regard to clinics, and the decisions of the conference last week on the same subject, gives good ground for believing that they express the considered views of the profession. We shall hope for further guidance on the hospital question, for it is important that its professional aspects should be thoroughly considered and the opinion of the profession presented to the public, as far as may be possible, simultaneously with the final report of the Voluntary Hospitals Committee appointed by the Minister of Health under the chairmanship of Lord Cave. We give elsewhere the text of the operative clauses in the interim report of this Committee. It will be seen that the members reached the unanimous conclusion that it is desirable in the public interest to maintain the voluntary hospital system of management. In expressing this view the Committee is in agreement with the British Hospitals Association, with King Edward's Hospital Fund for London, and, we believe, with the majority of the medical profession.

While it is recognized that it is undesirable that general hospitals should be converted into municipal or state institutions, thereby losing the advantages of voluntary administration and control, the necessity for finding additional sources of income is equally generally admitted. Lord Cave's committee makes a definite recommendation—namely, that in the interest both of the hospitals and of the approved societies a substantial part of the large surplus funds held by those societies should be used to provide contributions towards the cost of the maintenance of their members when in hospital. The total disposable surplus of the approved societies at the end of 1918 will, it is believed, when the valuation is completed, prove to be not less than seven millions. The Committee estimates that of persons treated at the hospitals, about 30 per cent. of the out-patients and a larger percentage of the in-patients are insured persons; the effect of hospital treatment is not only to relieve the patients from suffering and disability, but also to reduce the periods during which they are charged upon the insurance funds. The war, while depleting the hospital funds, has had the effect of greatly increasing the surplus available to the approved societies, and this would seem a special reason why the societies should give consideration to the claims of the hospitals. Section 21 of the Insurance Act, 1911, gave power to an approved society to grant subscriptions or donations to hospitals; it appears that this power has been little used. Lord Cave's committee has reason to believe that some of the larger approved societies would be glad to help the hospitals, and mentions two alternative methods: either the approved society might make a weekly payment towards the cost of the maintenance of any member who is an in-patient, or it might make a quarterly or yearly subscription to the hospital. The choice of method will require careful consideration, and is a matter upon which the medical profession will undoubtedly wish its opinion to be heard.

SPLENECTOMY IN PERNICIOUS ANAEMIA.

AMONG the numerous methods of treatment proposed and practised for pernicious anaemia the most heroic is splenectomy. It was introduced about ten years ago, and, although never popular in this country, it has not entirely escaped attention, for in 1914 Thursfield and Gow,¹ in an analysis of 21 cases collected from the literature, 11 being from Mühsam's clinic, showed that the red blood count was increased in all; with full recognition of the natural tendency of the disease to show remissions, they conclude that the operation afforded a fair promise of prolonging life, and even of making possible an active existence, at any rate for a time. In 1917 L. B. Wilson and Giffin² reported 7 cases at the Mayo clinic with temporary improvement; and in 1917 Giffin,³ in bringing this number up to 31, stated that there was a well marked favourable reaction in 78 per cent. of the patients who recovered from the operation, the immediate mortality of which was very low; most of the cases were so recent that no conclusions as to the duration of post-operative survival could be then drawn.

Giffin and Szlapka⁴ have now published a report on 50 cases, including the 31 mentioned above, in which the operation had been performed more than three years previously. The immediate operative mortality was 3 (or 6 per cent.), and, though higher than in chronic splenomegalic haemolytic jaundice, was considerably lower than in chronic splenic anaemia. Out of the 47 patients 42 have now succumbed, but 10 survived for more than three years, and 5 of these were alive and well in November, 1920, with an average of six years' illness, and an average interval since operation of four and a half years; the average total duration of the disease in the 10 cases was four and a half years, or longer than the average expectation of life (two to three years) in pernicious anaemia, and hence it is concluded that splenectomy prolonged life in 20 per cent. of the 50 cases. Estimation of bile pigments in the duodenal contents by a modification of Schneider's method suggested that haemolysis is less after than before operation, and there was some reason to believe that after splenectomy the progress of spinal cord changes was less rapid than would have been anticipated. Splenectomy appears to stimulate the bone marrow, for large showers of nucleated red cells may appear in the blood; but this is not an infallible index of the patient's post-operative progress, for several of the most successful cases showed few nucleated reds and only slight leucocytosis. The cases were selected from patients between 35 and 45 years of age, with a history of a year or less of illness, a favourable blood picture, namely, a polymorphonuclear rather than a lymphocytic predominance, absence of well-marked leucopenia, and with little if any evidence of degeneration of the spinal cord. But the writers finally conclude that there are not any features of the disease that can be relied on to indicate a favourable result from splenectomy, though cases with signs of acute haemolysis show a more pronounced immediate improvement after operation.

In contrast to this surgical estimate of the effect of splenectomy Bloomfield's critical analysis of 57 cases of pernicious anaemia treated in various ways at the Johns Hopkins Hospital may be recalled⁵; he found no definite evidence that transfusion of blood (26

cases), splenectomy, or elimination of focal infections prolonged life. By that time (1918) splenectomy had been abandoned at the Johns Hopkins Hospital, 6 out of 8 cases having terminated fatally without clinical improvement or prolongation of life in any instance. In five of the cases transfusion of blood was performed after splenectomy, but there was not any proof that the transfusion "held" any better after removal of the spleen. Bloomfield's figures of splenectomy are much smaller than Giffin's, but they were controlled by other series of cases treated in other ways, and thus are valuable.

THE NEW TUBERCULOSIS BILL.

THE National Insurance Act, 1911, required Insurance Committees to make arrangements to the satisfaction of the Insurance Commissioners (now of the Ministry of Health) for providing treatment in sanatoriums or other institutions, for insured persons suffering from tuberculosis; and powers were given to the Committees to extend this benefit, if considered desirable, to the dependants of insured persons. The Act had not been in force very long before it became apparent that if the best results were to be obtained those persons who were not insured would also have to be considered. The Government accordingly undertook to provide out of national funds one-half of the net expenditure incurred by county councils and county borough councils in connexion with those tuberculosis schemes which included provisions making them available for the entire population; we believe we are right in stating that at the present time there are only two or three of these authorities whose schemes have not been approved, and that the Ministry of Health withholds approval from any scheme which does not provide for the non-insured equally with the insured. As there seemed no longer any justification for differentiating between insured persons and non-insured persons, opportunity was taken in the National Health Insurance Act, 1920, to provide that sanatorium benefit, except in the case of Ireland, should no longer be included in the benefits conferred by the National Insurance Act of 1911, and after April 30th next this special benefit to insured persons ceases. This means that insured persons who are tuberculous will be entitled to appropriate treatment not because they are insured but because they are tuberculous. In those districts in which satisfactory arrangements for treatment have not been made by the county council or county borough council the inhabitants, after April 30th, will be placed at a disadvantage compared with those living in other parts of the country where the local authorities have had a fuller sense of their responsibilities. With the object of removing this disability in England and Wales, Dr. Addison, on March 16th, introduced the Public Health (Tuberculosis) Bill into the House of Commons. This measure lays down that adequate arrangements for the treatment of tuberculosis shall be considered to have been made by a county council or county borough council if the scheme for carrying out such treatment has received the approval of the Local Government Board, the Minister of Health, or the Welsh Insurance Commissioners. But in those cases in which a council has failed to make adequate arrangements for such treatment the Minister of Health may do what is required, after giving the council in question an opportunity of being heard on the matter. The cost of establishing and carrying out a scheme of the Ministry of Health is to be borne by the council concerned. Although the main object of this bill is similar to that embodied in the bill presented by Dr. Addison in November, 1920, and subsequently withdrawn, it differs in some material respects. For example, the bill of 1920 empowered county councils, county borough councils, and the Metropolitan Asylums Board to provide and maintain

¹ Thursfield and Gow: *St. Bartholomew's Hosp. Rep.*, 1914, i, 26.

² Wilson and Giffin: *Ann. Surg.*, 1915, lxxii, 153.

³ Giffin: *Journ. Amer. Med. Assoc.*, Chicago, 1917, lxxviii, 429.

⁴ Giffin and Szlapka: *Journ. Amer. Med. Assoc.*, Chicago, 1921, lxxvi, 290.

⁵ See BRITISH MEDICAL JOURNAL, 1918, ii, 63.

village settlements. It also enabled county councils, county borough councils, and metropolitan borough councils to engage in propaganda work relating to the prevention and treatment of tuberculosis and to contribute to the expenses of voluntary bodies established for the purpose of assisting persons suffering from tuberculosis or their families. These enabling clauses are not in the present bill, but a new clause has been inserted empowering the Minister of Health to give conditional approval of an institution for the treatment of tuberculosis or to withdraw his approval altogether. A very useful provision in the new bill is that which enables county councils and county borough councils to delegate their powers in relation to the treatment of tuberculosis to a committee upon which there may be appointed, either by the council or by the committee itself, persons who are not members of the council but who are specially qualified by training or experience in matters relating to tuberculosis. Two-thirds of the members of the committee must, however, be members of the council. The National Insurance Act, 1911, in Section 64 (3) made provision for establishing through an Order of the Local Government Board a joint committee from county councils, county borough councils, and other local authorities, except Poor Law authorities, for the purpose of providing sanatoriums and other institutions. This subsection is repealed in the present Tuberculosis Bill, and there is substituted for it a clause through which such a joint committee can only be formed from county councils and county borough councils. There can therefore be no co-operation between any local authorities other than these bodies, and in some quarters this will be looked upon as a distinct defect in a measure which in other respects calls for no adverse criticism.

THE MANCHESTER RADIUM INSTITUTE.

THE annual report of the Manchester and District Radium Institute, compiled by Dr. Arthur Burrows, radiologist, states that the number of patients applying for treatment during 1920 was 834, or 157 more than in the previous year; of these patients, 552 were suffering from malignant disease. Sixty-five cases of carcinoma were rendered free from signs and symptoms of the disease during the year; the organs affected were: the breast in 7 cases, the cervix of the uterus in 32, the larynx in 1, the lip in 3, the mouth and tongue in 5, the nose in 2, and the skin in 15. The number of rodent ulcers treated was 100, and of these 45 were cured. The number of cases of carcinoma of the cervix of the uterus seen during the year was 128; 3 were found unsuitable for treatment, 1 died, 8 were not improved, 29 abandoned treatment too early, 51 were improved, and, as already stated, 32 were well at the end of the year. The total is made up by 4 cases submitted to prophylactic radiation. The question whether the use of radium can replace operation in the treatment of early carcinoma in this situation is not yet decided, but the future is considered to be promising. Although the methods employed in the early years of the Institute were not as efficient as at present, a number of cases regarded at the time as inoperable and treated by radium were alive and well five, four, and three years later. During 1920 six cases classified as improved were regarded as inoperable before radium treatment was applied; they have since been operated upon. Appended to the report is a reprint of an article communicated by Dr. Fletcher Shaw and Dr. Burrows to the Section of Gynaecology of the Royal Society of Medicine on the use of radium to render possible hysterectomy for advanced carcinoma of the cervix; an account of this article was published in our columns of June 12th last, p. 806, and it was noted that during the discussion which followed its reading the opinion was expressed that it might be proper to operate on the second day after the completion of the exposure to radium; that is to say, at a time when the destructive action of the emanation on the malignant

cells has been completed, and the hard fibrous tissue, which at operation later on may make dissection difficult, has not yet been formed. The report now before us states that recently some operable cases had been given doses of radium, and the uterus removed three days later, but we do not find that the final result is stated. Of 86 cases of cancer of the mouth and tongue which applied for treatment, 3 received prophylactic radiation only, 17 were found unsuitable for treatment and 15 abandoned it too early, 5 cases died, and 9 were not improved; 32 were improved and 5 were well at the end of the year. Among the cases returned as improved was a considerable number in which the primary growth of the mouth had disappeared, but secondary glands were still present in the neck. The problem of secondary deposits still remains, it is said, the most difficult factor in dealing with cases of carcinoma of the mouth. Among the patients suffering from non-malignant disease were 54 cases of exophthalmic goitre; of these, 3 were deemed unsuitable for radium treatment, 10 did not persevere with it, 2 were not improved, 1 died, 37 improved, and 1 was well at the end of the year. A long period must be allowed to elapse before any definite opinion can be expressed. In a paper read to the Electro-therapeutic Section of the Royal Society of Medicine by Dr. Burrows and Mr. Woodburn Morison in March, 1920, the opinion was expressed that no other treatment gave such safe, uniform, and promising results as irradiation of the thyroid gland. In view of the alarming accounts of grave anaemia resulting from the handling of radium for therapeutic purposes, Dr. G. E. Loveday made some examinations of members of the staff of the Manchester Institute; at present the results are incomplete, but the inquiry will be continued. A new building provided with beds will be taken into use by the Institute this year.

CONGRESS OF RADIOLOGY AND PHYSIOTHERAPY.

THE forthcoming Congress of Radiology and Physiotherapy, organized by the Electro-therapeutic Section of the Royal Society of Medicine and the British Association of Radiology and Physiotherapy, will be held in London on Thursday, Friday and Saturday, April 14, 15th, and 16th, 1921, under the presidency of Sir Humphry Rolleston, K.C.B. The Congress will open at 10 a.m. on April 14th at the Royal Society of Medicine. On each day there will be papers and discussions in each of the three Sections—A, Radiology; B, Electrolgy; and C, Physiotherapy. On the morning of April 14th, Section A will discuss diseases of bone, Section B the action of the direct (constant) current on the tissues in health and disease, and in Section C there will be addresses on physical training and on the Chartered Society of Massage and Medical Gymnastics. In the afternoon Section A will meet at St. Bartholomew's Hospital; papers will be read on the intraperitoneal injection of oxygen, and visits will be paid to radiographic departments of selected hospitals. Members of Section B will visit the electrical departments of selected hospitals, and Section C will discuss the treatment of cardiac disorders by physical means. On April 15th Section A will discuss the normal stomach, Section B the uses of electrical methods in the diagnosis and prognosis of paralysis, and Section C physical treatment as an aid to orthopaedic surgery. In the afternoon Section A will discuss the abnormal stomach, and Sections B and C will meet for a joint discussion on re-education of muscles. On April 16th Section A will discuss deep therapy and radium therapy, Section B the physiological action and therapeutic uses of high frequency currents, and Section C backache and referred pain. In connexion with the Congress there will be an exhibition of x-ray and electrical apparatus, a dinner, visits to the Universities of Oxford and Cambridge, and a demonstration of physical training, organized by the Ling Association, at the Royal Albert

Hall on April 16th, at 2.30 p.m. Representatives from France and Belgium will take part in the proceedings, and communications may be made in French or English. The Secretary-General is Dr. G. Harrison Orton, and the Honorary Treasurer, Dr. J. Metcalfe, to whom subscriptions (2 guineas for English members and 40 francs for French and Belgian members) should be forwarded at the Royal Society of Medicine (1, Wimpole Street, London, W. 1).

THE MEDICINE OF ANCIENT EGYPT.

PROFESSOR ELLIOT SMITH read an interesting paper on the ancient medicine of Egypt before the Section of the History of Medicine of the Royal Society of Medicine on March 16th. In the whole of its history, he said, medicine had been drawing upon knowledge not primarily acquired for the diagnosis and treatment of disease; and the further back into history inquiry was pushed, the more striking did this fact appear. Egypt occupied an important place in the beginnings of medicine. The elaborate methods followed for the preservation of bodies made it possible to ascertain the nature of some of the disorders from which the individuals had suffered during life. The practice of mummification itself had a far-reaching effect in acquainting men with the nature of materials that would preserve the body, and certain of these materials, such as balsams, were used later on as therapeutic agents. Among the numerous photographs exhibited was one of a fractured jaw revealing a blood stain after twenty centuries. So wonderful was the preservation of the bodies that even the contents of the alimentary canal could be examined. In the stomachs of small children the remains of a mouse were often found. The custom of giving a mouse as a remedy to children *in extremis* was mentioned by Pliny, and had its echo in our own time when, in some parts of the country, the mouse was thought to have healing properties—a striking instance of the persistence of custom through long ages. The idea of the mouse as a life-giver was probably associated with the fact that after the inundations of the Nile mice appeared in great numbers, and it was a belief firmly maintained by the Egyptians that they were formed of Nile mud, the substance of the life-giving god. The fundamental principle underlying the practice of medicine in Egypt was that illness was due to deficiency of vital substance, and that, therefore, the rational method was to give to the patient an additional dose of such substance. Blood was regarded as the substance of life, and if blood was not given in illness, red ochre or some red-coloured substance was substituted. Butter, which was often found in the mouths of mummies, was supposed to perpetuate existence by drawing upon the life-giving properties of the cow. Lotus flowers and other plants were used in the same way, and although the great majority possessed no therapeutic properties, some came to be used as drugs, and their use continued even into modern times. Professor Elliot Smith next showed photographs of splints of the pyramid age, and remarked that the same type existed in Abyssinia to-day. Sculptures had been discovered showing that the operation of circumcision or some simpler form of incision was practised in the earliest beginnings of Egyptian history. Other sculptures showed that patients were massaged, though with what object was not clear. The Egyptians never put the knowledge of dissection, acquired by embalming, to any practical use in medicine, but they made it possible for the Greek physicians of about 300 B.C. to practise dissection in Alexandria, a practice forbidden by popular prejudice in Greece itself. In the bodies of many persons of over 30 years of age found in pre-dynastic cemeteries there was evidence of arthritis in various stages. Several photographs showing extensive mastoid disease were exhibited. Another series showed tuberculous disease of the spine with unmistakable evidences of psoas abscess. At the time he began his investigations in Egypt certain

French observers had expressed the view that the appearances seen in bones from some pre-dynastic bodies were due to syphilis. His own examination of the specimens, however, showed that the damage to the bones had been inflicted by beetles after death. Altogether, with his collaborators, he had examined some 40,000 bodies in every part of the Nile valley belonging to every period of Egyptian history; in no single case was evidence of syphilis detected. He had found no evidence that trephining was practised in ancient Egypt, although the operation was performed in other parts of North Africa. The point was illustrated by a photograph showing a depressed fracture in the process of healing, which had erroneously been supposed to be an example of trephining. Skulls from the period when heavy full-bottomed wigs were worn showed characteristic thinning symmetrically disposed on the parietal bones. In the early Christian period one example of leprosy and one of gout had been found among aliens from Syria, but none of either disease at earlier dates. In concluding his lecture, Professor Elliot Smith recalled that Herodotus had stated that the bodies of women were not mummified immediately, as in the case of men, but were kept for a few days. This statement was confirmed by finding flies and larvae embedded in the resinous material used in the process of preservation.

BIRTHS, MARRIAGES, AND DEATHS.

THE Registrar-General's quarterly return for England and Wales shows that the births registered in the fourth quarter of 1920 numbered 208,380, being 21,500 fewer than in the preceding three months, and 15,200 fewer than in the corresponding quarter of 1919. The registered deaths were 115,603, being some 21,900 more than in the preceding three months, and 843 more than in the corresponding quarter of 1919. The births corresponded to an annual rate of 22 per 1,000 total population; the deaths to an annual rate of 12.5. Influenza was said to be either the primary or a contributory cause in 1,396 deaths, or 1.2 per cent. of the total deaths registered. There was no fatal case of small-pox. Infant mortality, measured by the proportion of deaths under 1 year to registered births, was equal to 85 per 1,000, being 19 per 1,000 below the average of the ten preceding fourth quarters. While the mean temperature for the quarter was above the normal in all districts, the total rainfall was everywhere below the normal, and throughout the greater part of the country the mean daily amount of sunshine was above the normal. As has already been indicated in the Registrar-General's provisional return, the numbers of births and marriages in England and Wales during 1920 were the highest ever recorded, while the number of deaths was the lowest since 1862, when the population was about 20 millions. The natural increase of population (by excess of births over deaths) was not far short of half a million in 1920, and this also was the greatest on record. To make a bumper year complete, the marriage rate was higher and the total death rate and the infant mortality were lower than in any other year on record. Even the birth rate had something to be proud of, being the highest since 1909.

CANCER AND THE PUBLIC.

WHEN the lay press takes to the discussion of medical problems, as it does from time to time, the journalistic efforts are generally ludicrous and often pathetic. Of all the problems there is none more appealing to the excitable young journalist than that of cancer. Here he can dwell on "the mysteries that baffle our greatest scientists," or animadvert on the conservatism or worse of our doctors, who are sitting with folded and nerveless hands, incompetent to stay the awful scourge. Unaware of what is known and what is being done, he too often assumes that the whole subject is hid in impenetrable darkness, and that it is his duty to stir up a lethargic profession. He may

even tell us sometimes how to set about the solution. From the foreign correspondents of the daily journals we learn, at one time, that some savant has found the cause of cancer; at another, that a second savant, of whose name and existence we were ignorant, had hit upon the cure. Some newspapers, indeed, leave the subject severely alone, but in these days, when the man in the street clamours for a simple exposition of Einstein's theory, and problems in biology are freely discussed, it is to be expected that the public may reasonably demand a stocktaking of the knowledge that has been gained in the study of malignant disease, for there can be few families in this country in which some member has not died of cancer. It is unfortunate, however, that the writers who talk it upon themselves to instruct the interested public are seldom in a position to know the facts of the case. Recently there has been something like an epidemic of "stunt" articles, and the alleged increase in cancer mortality in England and Wales as disclosed by the Registrar-General's report has formed the text for a mass of pseudo-scientific nonsense. It is admittedly difficult to treat the questions adequately in short compass or in popular language, and some of our laboratory experts object to having their plants so frequently pulled up to display the roots. Amongst these newspaper articles on cancer we have noticed one which should serve as a model to the journalist. The writer of an article in the *Evening Standard* of March 16th, discussing the question of the increase of cancer, gives ten facts known about malignant disease which it is of advantage to the public to know. Whoever the writer may be he knows the subject, and has the ability to put the position clearly in few words, and we gladly congratulate the newspaper on the article. *Si sic omnes!*

IMPORTED SMALL-POX.

WE are indebted to Dr. D. S. Davies, M.O.H. Bristol, for a copy of his report on a recent outbreak of small-pox in that city. As on several previous occasions during the last thirty years in Bristol, the first case was a man engaged in unloading ships. This man, a dock labourer, had been working in three ships at Avonmouth between November 16th and December 22nd. It seems probable that he contracted the disease from infected sacks, as one of the vessels came from an infected Rumanian port. Some time in December he apparently developed a mild attack of small-pox, which did not cause him to be absent from work for more than four days. He had been vaccinated in infancy and showed three marks. On January 22nd a medical examination revealed the presence under the thick skin of the sole of one undoubted deep-seated pustule. He communicated the disease to his wife and son, and, so far as is known, to them only. The wife, who had been vaccinated in infancy and showed four good scars, sickened on January 2nd, developed a modified discrete eruption on January 4th, and had secondary fever. The son, aged 5, unvaccinated, sickened on January 2nd, and had the eruption on January 4th; it was a semi-confluent attack, becoming haemorrhagic in the pustular stage, and the child died on January 12th. The other child of the family, a daughter aged 2, who had been vaccinated in 1920 in order to qualify for a baby show, though equally exposed to infection, has remained in perfect health. There had been no small-pox in Bristol since 1915, and the nature of these two cases was at first overlooked, and they were not notified until January 8th. Between January 2nd and January 8th twelve persons visited the house; one, a woman aged 36, who had been vaccinated in infancy, nursed the patients daily, and was revaccinated on January 9th; on January 17th she had fever, and an eruption on January 19th. Her daughter, a girl aged 8, unvaccinated, visited her mother on January 5th; she was vaccinated on January 9th, and had fever on January 16th, and the eruption on January 18th. A

domestic servant, aged 24, a sister of the woman who nursed the child that died, was another visitor; she had not been vaccinated in infancy but was vaccinated on January 10th; she had fever on January 17th and the eruption on January 19th. Another woman, aged 23, sister of the last named, unvaccinated in infancy and vaccinated on January 10th, also visited the cases; she developed fever on January 17th, and the eruption on January 20th. All these patients recovered. The eight other persons who visited the house escaped infection. In spite of the delay mentioned subsequent cases were, it will be noted, entirely limited to "home-contacts." The incident illustrates the value of informed supervision. In 1903 there were fifteen introductions of small-pox, and in nine of these no resulting case followed, nor in any instance did more than ten cases result. To maintain such control requires experience coupled with much work, the necessity for which might be avoided by the simple expedient of vaccination.

CONGRESS OF MILITARY MEDICINE.

WE announced some time ago that the Belgian Army Medical Service was organizing an international congress of military medicine and pharmacy. This will be held at Brussels from July 15th to the 20th next, under the presidency of Dr. Wibin, Inspector-General of the Belgian Army Medical Service. The following subjects will be under consideration: (1) The general organization of army medical services and their relations with Red Cross societies; (2) clinical and therapeutic study of poison gases used during the war by the Central Empires, the results of their action upon the body and their influence upon the pensioned soldier; (3) the antituberculosis and antiveneal campaigns in the army; (4) the lessons of the war in the treatment of fractures; (5) purification of water on campaign. All reports and communications on the above subjects should be addressed to the Secretary-General of the Congress, Military Hospital, Liège, Belgium, before May 1st.

DURING the annual meeting of the British Medical Association at Newcastle, the Popular Lecture will be delivered by Professor Arthur Keith, M.D., F.R.S., on Friday, July 22nd, at 7.30 p.m. The subject he has chosen for his lecture is "Evolutionary wounds, their healing, and the part they play in the evolution of the human body." The lecture will be illustrated by lantern slides.

At the next meeting of the British Association, to be held in Edinburgh under the presidency of Sir Edward Thorpe from September 7th to 14th, 1921, Sir Walter Fletcher will be President of the Section of Physiology, Professor C. Lloyd Morgan President of the Section of Psychology, and Sir James Frazer President of the Section of Anthropology. A joint sectional meeting will be held to discuss problems of biochemistry.

Medical Notes in Parliament.

Venereal Disease.

DISCUSSION IN THE LORDS.

LORD WILLOUGHBY DE BROKE moved in the House of Lords, on March 16th, that the report of the committee on venereal diseases, appointed by the National Birth Rate Commission, should be printed and issued as a Parliamentary paper. He recalled that the committee was presided over by the Bishop of Birmingham; that its membership included the heads of most of the religious denominations, and also women doctors and physicians and surgeons of the highest standing; further, that it was appointed with the approval of the Minister of Health.

Having, on behalf of the Society for the Prevention of Venereal Disease, expressed entire concurrence with the view that there should be a national effort to assert the moral obligation of chastity, Lord Willoughby de Broke dealt with a

passage about self-disinfection, in which the Committee held that no obstacle should be placed in the way of people obtaining the right disinfectants from chemists, and that, if necessary, the law should be altered to enable them to do so. In his opinion it was not really necessary to alter the Act of 1917, except perhaps in the way of making it clearer. In one section of the Act chemists were forbidden to expose or advertise or to recommend any drugs, medicaments, etc., or to hold out any of these things as cures or as preventing venereal disease. At the end of that section there was a paragraph to the effect that nothing in it should apply to what was sanctioned by the public health authority. To carry out the idea of self-disinfection which was visualized by the Committee it would be necessary only that the Ministry of Health should put that section into operation, and should, through the public health authorities, enable chemists to sell to people who asked for such things as were duly authorized. He and others who favoured the policy of self-disinfection did not shut their eyes to other means which might be adopted for combating the evil; but this policy had the advantage that it could be carried out immediately by the efforts of the Ministry of Health. Legislation to make communication of the disease a crime or for compulsory notification would, he reminded the House, in any case be difficult to carry. The official policy here had been to exhort people not to commit fornication, and to tell them if they did they should consult a doctor either before or immediately after symptoms arose. That policy had failed in its object.

The Bishop of London pleaded for a consideration by the Government of the report in its entirety. With regard to the policy of disinfection, he said it was impossible to imagine a greater contrast than was to be found between the evidence of Sir Archdall Reid and that of Colonel Harrison. What he gathered from his study of the report was that even in the army a system of disinfection was, except under skilled instruction, practically valueless, and that Colonel Harrison, who had hoped for much from the practice, had been grievously disappointed. If that were the case with the army, it would be almost impossible to apply the proposal in the case of civilians. It appeared also, according to his reading of the report, that the fancied security might give rise to greater licence to sin, with the result that the disease might possibly spread. From the moral point of view such a system, he considered, would debauch the conscience of the community. He did not say that any individual should not have the right to purchase disinfectant or cure for any disease from any chemist. He failed to understand, however, how a personal obligation could be enforced without penalties in case of refusal. He agreed broadly, however, that we had reached a stage when strong measures were needed to meet the situation; and it was for that reason he had introduced his bill.

Lord Sydenham, speaking for the National Council for Combating Venereal Diseases, reaffirmed his view that there was no reason to expect any material result if disinfection were tried among the civilian population. Lord Willoughby de Broke apparently wanted the Government to start a propaganda to enforce disinfection upon the population, and his society was making extensive efforts in this direction. Any chemist could, in fact, sell disinfectants now, though he might not advertise them as a specific against the disease. Lord Sydenham agreed that there was no reason why the nature and effects of disinfection, if properly carried out, should be kept secret. But the Government would be ill advised if it issued a statement which might be misunderstood with consequent increase of infection.

Lord Gorell explained why the National Council for Combating Venereal Diseases had been unable to take up an invitation for a joint conference upon the report with the other society and any other bodies desiring to join. The Council could do nothing in any important matter of policy before there had been a general meeting and the conclusions of that meeting had been confirmed by a second. The first meeting was fixed to take place on March 22nd. Points of policy had been, however, unanimously adopted by a representative executive meeting, and had received the full approval of the Ministry of Health. The report of the Bishop of Birmingham's committee, said Lord Gorell, was the work of a private body—a subcommittee of the National Birth Rate Commission—and could not be regarded as official. It was valuable, but not a document upon which lines of policy could be founded. He hoped that the points which his executive had agreed upon might be adopted by his society and prove acceptable to Lord Willoughby de Broke and his society, but it was impossible to prejudge that matter. On the question of immediate self-disinfection he thought that there could be no doubt that, with proper application, in the enormous majority of cases it would be a preventive; but on this subject he wished to quote a letter he had received from a member of the Bishop of Birmingham's committee who had been for twenty-five years a surgeon in the London Lock Hospitals and now controlled the venereal department of Charing Cross Hospital. This letter, he thought, showed the grave doubt as to the possibility of any authoritative pronouncement being made at the present time.

Viscount Knutsford, after giving figures with regard to new cases in the London Hospital, urged that it was time for vigorous action undeterred by mere speculative theories as to moral results. If he were Minister of Health he would institute a most energetic propaganda, preaching continence and chastity and pointing out the horrors of the disease in the most awful colours. He would insist on the necessity of self-disinfection; he would emphasize that even disinfection was by no means certain in its action; he would open more clinics. But the

great difficulty with regard to the last was that 40 per cent. of the people who came did not continue the treatment till cured; and that should be made an offence.

The Earl of Malmesbury agreed with Lord Gorell that to publish the evidence of a more or less private committee as a parliamentary paper would be entirely contrary to precedent. But, speaking as a member of the joint committee which investigated the several Criminal Law Amendment Bills, hearing much evidence, he entirely agreed with Lord Knutsford as to the call for action by the Ministry of Health. In Committee he was much more impressed by the evidence of Sir Archdall Reid than by that of Colonel Harrison.

Lord Askwith and the Earl of Clanwilliam supported the views of Lord Willoughby de Broke.

Viscount Peel, Under-Secretary for War, thought sufficient attention had not been paid in the discussion to the report of the Inter-Parliamentary Committee presided over by Lord Astor. That Committee reported unanimously against the advocacy of self-disinfection for the civilian population, and they came to that decision after considering the war experience of the various armies. In regard to promoting a policy for self-disinfection it was desirable, he thought, that they should arrive at some definiteness as to what medical opinion was; but it was very much divided, and action should only be based on some decided preponderance on one side or the other. Another danger very strongly pointed out by doctors was that disinfectants might be used in many cases as a substitute for the treatment of the disease. This would constitute a very grave and serious danger. Besides, there were the moral and social objections to be considered. He could offer no definite information on behalf of the Ministry of Health, but the question was at present receiving, or would shortly receive, the attention of the Cabinet. The report of the Bishop of Birmingham's committee not being official, he could not, on grounds of economy, agree to the request that the Government should publish it.

Lord Willoughby de Broke regarded the reply of Lord Peel as profoundly disappointing. He thought the Ministry of Health might do much to encourage self-disinfection without invoking penalty. As to medical opinion, he said without fear of contradiction that the vast mass of instructed medical opinion in the country was on his side in the matter, and that a preponderance could be claimed in favour of having a cautious, wise, and scientific system of self-disinfection laid down by the Government of the day, vouched for by the proper authority—namely, the Ministry of Health acting through the local health authorities.

The Archbishop of Canterbury hoped it would not be thought that they lacked belief that the subject would be handled in the best possible manner by the Ministry of Health if they did not support the proposal for publishing the report as a Parliamentary paper.

On a division, 9 voted for publication and 29 against.

Criminal Law Amendment Bill.

Upon report on the Criminal Law Amendment Bill in the House of Lords, on March 17th, Lord Dawson of Penn explained why he did not move an amendment which he had put down to qualify Clause 1. This clause reads:

"It shall be no defence to a charge or indictment for an indecent assault on a child or young person under the age of 16 to prove that he or she consented to the act of indecency."

Lord Dawson intended to move that the section should not apply where the child had attained the age of 13 unless the person charged had at the time of the offence attained the age of 18. His object in presenting this amendment was to secure different treatment for youths from that meted out to older offenders, his belief being that in dealing with the younger offenders the law was not dealing with a perverted instinct but rather with the overflow of a natural instinct at a time when restraint was imperfectly developed. He had, however, since framing the amendment had a conversation with representatives of the Home Office who had convinced him that in application the amendment would not have the object he had in view and that it would be more successfully achieved by administrative means. Great discretion was already exercised by chief constables and other authorities, and it was very rare for these young persons to be brought before a court and indicted as criminals. It was held also that the amendment might weaken administrative authority in those few cases amongst young persons which it was desirable should be brought before the justices; hence he did not pursue the matter.

Some drafting amendments have been made, but otherwise the bill passed the report stage as in committee.

Hospital Finance Committee's Report.

In reply to Sir Godfrey Collins, on March 17th, Dr. Addison said that the Committee on Hospital Finances, the substance of whose interim report is given on page 468, hoped to complete the hearing of evidence by the beginning of May, and to present their final report before the end of that month.

Dangerous Drugs Act Regulations.

The Departmental Committee set up by the Home Office to consider what regulations shall be made under the Dangerous Drugs Act has held several meetings under

the chairmanship of Mr. Chester Jones. A précis of the evidence given this week on behalf of the British Medical Association by Dr. Bone and Dr. Cox is printed in the SUPPLEMENT at page 82.

The Parliamentary Medical Committee.

The Parliamentary Medical Committee, which consists of medical members of the House of Commons and university representatives, met on March 21st. Lieut.-Colonel Nathan Raw presided. Captain Elliot is honorary secretary of the group. Sir Philip Magnus raised the question of the security of tenure of medical officers of health. He presented a draft bill, and it was agreed that this should be brought up to date and resubmitted at a subsequent meeting. It was further agreed that reports of the proceedings of the Committee should be communicated to the medical newspapers.

A deputation from the Medico-Political Union consisting of Dr. Weply, Dr. Gordon Ward, Dr. Greig and Dr. Peter Macdonald, submitted their views on two matters: (1) The new medical record cards, and (2) the new regulations on the transfer of practices and their bearings on the selling value of practices.

The Scottish Board of Health.—Major Glyn asked the Minister of Health, on March 15th, if all instructions drafted by the Ministry of Health regarding forms to be filled in, were invariably submitted to the Scottish Board of Health, or whether the Scottish Board of Health were brought into consultation when such forms were under consideration; and whether, should any difference of opinion arise, the Secretary for Scotland would decide if the desire of the Ministry of Health should apply to Scotland. Dr. Addison replied that the Ministry of Health were not concerned with forms applicable to Scotland except in the case of forms prepared by the Department, of building material supplied, in regard to which the Scottish Board of Health were consulted. The answer to the latter part of the question was in the affirmative.

Medical Staff of the Ministry of Health.—In answer to Sir T. Bennett, on March 16th, Dr. Addison said that the number of whole-time and pensionable medical men employed in the Ministry of Health and the Welsh Board of Health was 71.

State Contributions to Health Services.—Mr. T. Thomson asked, on March 16th, whether, in view of the results obtained from the activities of local authorities in the exercise of their powers for the amelioration of the health conditions of their areas, the Minister of Health would see that no curtailment took place in the grants made from the Exchequer in support of school clinics, maternity welfare centres, the care of tuberculous cases and similar work, when preparing his estimates for the coming financial year. Dr. Addison replied that the Minister for Education was responsible for the provision of school clinics. As regards the other services mentioned, the amounts inserted in his own estimates for the next financial year were such as were required to provide the State contribution towards existing services and commitments and also for such extension as could be shown to be necessary for immediate and urgent health requirements. Lieut.-Colonel Raw asked what grants were made by the Ministry of Health towards the cost of treatment of tuberculosis, and what proportion of the total expenditure was represented by those grants. Dr. Addison said that grants amounting approximately to £97,000 would be made during the current financial year towards the expenditure of local authorities on the treatment of tuberculosis. The grants represented less than a farthing in the pound on the total sums voted by Parliament for the supply services of the country. In addition to these maintenance grants, grants in aid of capital expenditure amounting to £36,000 would also be made.

Medical Record Cards.—Asked by Sir W. Davison, on March 16th, the precise composition of the committee set up to deal with medical record cards, Dr. Addison said it was under the chairmanship of Sir Humphry Rolleston, and was composed in all of seventeen persons, of whom fourteen were medical men. Of the fourteen medical men on the committee four were in insurance practice at the time, and the fifth had been in such practice until shortly before the committee's appointment. Mr. A. T. Davies asked the Minister of Health, on March 17th, whether large numbers of patients' record cards had been inaccurately filled up by medical men or others; whether the numbers had increased during the past three months; whether he was satisfied with the present method of inspection; and to what he attributed the growth of inaccuracy in these returns. Dr. Addison replied that in the filling up of 13,000,000 cards a certain number of inaccuracies was inevitable, but his information was that the tendency was all in the direction of improvement, and the last part of the question did not therefore arise. The answer to the third part of the question was in the affirmative.

The Bloomsbury Site for London University.—In reply to Sir J. D. Rees, Mr. Chamberlain, on March 16th, said that no decision had been taken on the question of the period during which the Bloomsbury site was to be kept for the new building for London University. The agreement with the vendor contained the clause under which, if before April 1st, 1926, the Government gave notice that they found it impossible to use the property for the purposes of the University, the vendor had an

option to repurchase it for the price given, and if he did not exercise the option the restriction of the use of the site for purposes of the University was removed. During the period of waiting the property would be administered in its existing form, and in the improbable event of the abandonment of the scheme it could be for the Government of the day to determine whether to dispose of the site, or to divert it to other purposes.

General Disease of the Rhine.—Captain Elliot asked, on March 16th, whether the Secretary for War was satisfied with the venereal disease admission rate of the army of the Rhine, which showed no reduction from the admission rate as stated by Mr. Churchill in May, 1920; whether this meant that in six years the admissions for venereal disease would have equalled the total strength of the force; and whether every possible effort was being made to reduce the rate, including the spread of information as to self-disinfection. Sir L. Worthington Evans said the incidence of the disease on the Rhine was not satisfactory, and had, indeed, been anxiously considered ever since the area was first occupied. The figures given by Mr. Churchill last May were approximate only. The corrected figures now available showed that during the first quarter of 1920 the ratio admitted to hospital for venereal disease was 45.81 per 1,000 of the strength. The ratio for the last quarter of 1920 was 40.22, and for the month of January last it was equal to a quarterly ratio of 37.80. These figures indicated a gradual improvement. The admission rate included every case admitted to hospital—relapses and readmissions for further treatment, as well as primary infections. Amongst the efforts being made to reduce the amount of disease was the spread of information about self-disinfection as followed in the United Kingdom, where the incidence was now, and was for the year 1920, at a lower level than at any other time in the history of the British Army.

Civil Policy as to Venereal Disease.—Viscountess Astor asked, on March 16th, whether the Minister of Health proposed to depart from the policy of dealing with venereal disease which was adopted by him on the unanimous recommendation of the Interdepartmental Committee which reported last spring after taking full evidence. Dr. Addison replied that the question whether any modification in policy was required was now under consideration, and he was not at present in a position to make a definite statement on the subject. Dr. Farquharson asked if Dr. Addison was aware that the great weight of evidence given before the Interdepartmental Committee and before the Birth Rate Commission was entirely against the idea that packets for self-disinfection were efficacious means for stopping or preventing venereal disease. Dr. Addison said he believed the statement to be correct, and also that it was supported by the experience of the various armies; but the whole matter was under consideration.

The Disability Pensions New Warrant.—On inquiry by Sir T. Bramson, Mr. Macpherson stated, on March 17th, that in the case of all soldiers whose claim to pensions or grants for services during the war had been dealt with under previous warrants, return to the previous warrant might, if more beneficial to them, be applied with retrospective effect as from September 3rd, 1919. Similar provision was made in the Order in Council dated June 11th, 1920, for seamen and marines. There had been delay in the issue of the Order, but this did not obstruct the process of award.

Neurosthenic Patients: Treatment. In reply to Sir Walter de Frece, on March 17th, Mr. Macpherson said that the facilities for the treatment of ex-service neurosthenic patients had already been greatly extended, and the arrangements made by the Ministry were still in process of development. It would need a prolonged investigation to ascertain the total number of men treated since the formation of the Ministry. The number of officers and men at present under treatment was 9,921.

Blind Welfare Advisory Committee.—Dr. Addison said, in reply to Mr. Myers on March 17th, that the term of service of the members of the advisory committee on the blind expired in December last; that he was proposing to set up a new advisory committee, and hoped to announce its composition very shortly.

Indian Medical Service: Travelling Facilities.—Lieut.-Colonel Raw asked, on March 16th, when the long promised concessions to officers in the I.M.S. with regard to passages to and from India on duty, would be brought into operation. Mr. Montagu replied that he was not clear as to the reference. Officers proceeding to and from India on duty were granted free passages; possibly Lieut.-Colonel Raw was thinking of officers proceeding on sick leave. In those cases grant of free passages was sanctioned in June last.

Medical Service on River Gumboats in China.—Commander Bellairs asked, on March 17th, whether there was a medical staff of a surgeon and a sick berth attendant to a remaining crew of twelve men in each of our river gumboats in China; whether the First Lord of the Admiralty was aware that the American and French gumboats did not carry doctors, and whether the Board would consider the economy that could be made by relying on the missionary doctors along the river. Sir James Craig replied that the Upper Yangtze had two gumboats with one medical officer and one sick-berth rating between them. The Lower Yangtze had eight gumboats with five medical officers and six sick-berth ratings. The West River had four gumboats with two medical officers and two sick-berth ratings. There was no information as to whether the American or

French gunboats carried medical officers. It was not considered desirable nor practicable to rely on the services of the missionary doctors. The complement of the vessels varied from twenty-five to fifty-three. Owing to the climate and the difficulty of obtaining good vegetables, sickness had to be provided against, as well as the possibility of casualties from local disturbances.

Naval Hospital at Yokohama.—Sir James Craig, in answer to Commander Bellairs, on March 17th, gave the following information as to the British Royal Naval Hospital at Yokohama: Accommodation, 87 patients; Staff, 1 surgeon commander, 4 sick-berth staff and 13 native employees; maximum number of patients under treatment last year 8, minimum number, nil.

Nurses' National Fund.—Mr. John Davison asked, on March 14th, whether the Government had any control over the administration of the Nation's fund for nurses, and whether it was a fact that although one of the main objects of the fund was to benefit nurses who were in precarious circumstances owing to after-war conditions, or were suffering ill health as a result of war strain, out of a total of nearly £150,000 only £2,144 had been applied to this purpose, while nearly £40,000 had been given to the College of Nursing. The Prime Minister replied that the Government had no control over the fund; and he had no knowledge how it was administered. He advised Mr. Davison to direct his inquiries to the Charity Commissioners.

Antimony Treatment for Ex-Service Men.—Captain Thorpe asked the Minister of Pensions, on Monday, whether in view of the successful treatment by antimony of ex-service men who contracted bilharziasis during the late war, he could hold out any hope of similar treatment being at public expense to pensioners who contracted the disease in the South African campaign and were still suffering. Mr. Macpherson replied that the matter was under consideration.

Food in War and Peace.—Mr. Sugden asked the Minister of Health, on March 21st, what steps he was taking to alter the food products instituted in war days as substitutes for a more nourishing type, to protect the physique of the people, especially that of industrial workers and their children, and what action he proposed to take to ensure that local authorities had these matters under close and practical scrutiny. Dr. Addison said he was not sure what particular classes of products Mr. Sugden had in mind. Substitutes such as margarine had generally been adopted by consumers for economic reasons, and so far as he was aware all staple articles of food were now freely available. Local authorities generally had resumed the active enforcement of the Food and Drugs Act, and the information obtained from their reports did not indicate that there was any increase in adulteration.

Artificial Limbs.—Mr. Macpherson informed Mr. Aubrey Herbert, on March 21st, that light metal limbs made by Desoutter were supplied by the Ministry of Pensions when specially recommended by a board of surgeons for reasons which made the supply of this particular limb essential. Where it was considered by the surgeons that another type of limb would be equally satisfactory, the issue of a Desoutter limb was refused on grounds of economy.

ROYAL MEDICAL BENEVOLENT FUND.

At the meeting of the Committee held on March 8th seventeen cases were considered, and £175 voted to fourteen applicants. The following is a summary of some of the cases relieved:

Widow, aged 60, of M.R.C.S. who died in February, 1921. Applicant's husband had been unable to practise for some time owing to failing eyesight and old age, and the small amount of £60 left at his death from the practice was much reduced by funeral expenses and debts. The widow's sole income is £37 10s., and at present her rent and rates amount to £32 per annum.

Daughter, aged 49, of M.R.C.S. who died in 1873. Applicant was operated on in June, 1920, and since has been living on her small savings and cannot possibly return to nursing, her profession, for some considerable time. She asks for temporary assistance whilst incapacitated.

Widow, aged 44, of L.R.C.P. and S.I. who died in 1918. Applicant was left with two children totally unprovided for, and asks assistance towards the education of the children. Her father-in-law makes her an allowance, but this help may cease at any time; she argues this by letting apartments. Help has been given by the Irish Medical Benevolent Fund and the Professional Classes War Relief Council. Her rent is £48 per annum.

Daughter, aged 65, of M.D. Lond. who died in 1885. Applicant has supported herself by needlework, but owing to advancing years and failing eyesight, cannot do the amount of work necessary to pay her way. The amount she now earns is about 18s. a week, and her rent is 4s. a week. The Fund rendered assistance to the applicant's sister some time ago, but she is now in the infirmary.

Daughter, aged 50, of M.R.C.S. who died in 1870. Three sisters live together in one room, one an invalid. Applicant made about £50 this year at nursing, but owing to ill health has applied to the Fund for assistance. The rent of the room is 16s. a week.

Subscriptions may be sent to the Honorary Treasurer, Sir Charters J. Symonds, K.B.E., C.B., F.R.C.S., at 11, Chandos Street, Cavendish Square, London, W.1.

The Royal Medical Benevolent Fund Guild is overwhelmed, in these days of exorbitant prices for clothing and household necessities, with applications for coats and

skirts for ladies and girls holding secretarial posts, and suits for working boys. The Guild appeals for second-hand clothes and household articles for the benefit of the widows and children who in happier times would not have needed assistance. The gifts should be sent to the Secretary of the Guild, 43, Bolsover Street, W.1.

THE PREVENTION OF VENEREAL DISEASE.

POLICY OF THE NATIONAL COUNCIL.

In view of recent events and controversies, the executive of the National Council for Combating Venereal Diseases has drawn up a statement of what it considers should be the general policy of the Council, and this was submitted to the full quarterly meeting of the Council on March 22nd.

It is declared, in the first place, that the public must be officially informed of the prevalence, causes, and consequences of venereal diseases. As by far the most important cause is promiscuous sexual intercourse, the question cannot be dealt with apart from social and moral factors, with regard to which all medical practitioners, parents, and teachers must feel their separate responsibility. Parents must instruct their children, not only in the facts of sex, but in the moral obligations thereby imposed. The action of public health authorities in dwelling in their publications on the medical prevention of these diseases, to the exclusion of moral considerations, is deprecated. The means used to prevent the spread of the diseases must not be such as to weaken the deterrents or have any appearance of condonation. At the same time, the executive recognizes that there are individuals who do not respond to the moral or social appeal, and who may not only contract the diseases themselves but may be a means of infection to others, often innocent persons. The development of disease in these irresponsible and immoral individuals must be prevented as far as this is possible without condonation. The public recommendation, by advertisement or otherwise, of protective disinfectants must result in giving increased notoriety to quack remedies, and is deprecated; while detailed official instructions as to the use of these disinfectants, issued with the sale, will have the appearance, not only of official condonation but of official guarantee to the purchaser against contracting the disease. Furthermore, such instructions, unless scrupulously followed after definite and personal tuition, may aggravate rather than diminish the incidence. The public should be warned against attempting self-treatment. On the constructive side, the executive urges that strict personal cleanliness, with information as to the part played by dirt and disease organisms in causing infection of the genital passages, should be inculcated as part of the instruction in sex hygiene. If an individual has incurred, or believes that he (or she) has incurred risk of infection, he must be brought to understand that it is his bounden duty to cleanse himself thoroughly and immediately; delay or inadequacy may lead to development of the disease. If any signs or symptoms, however slight, make their appearance it is his duty to attend promptly at a venereal diseases clinic. It should be officially stated that it is only by fulfilling these duties that the individual can make such amends as are possible for what is a social as well as a moral offence. The existing cleansing and disinfecting centres should be continued experimentally, subject to careful supervision, and any decision as to their extension should depend on the experience obtained. The Ministry of Health, finally, is asked to accept publicly this considered policy as one which is essential to the successful waging of warfare against these diseases in this country.

The statement of policy, of which the above is a summary, was adopted by the National Council.

DR. GEOFFREY LUCAS was entertained to dinner at the Palace Hotel, Aberdeen, on March 17th, by a large and representative gathering of the medical profession and residents of Aberdeen and district and Banchory, the occasion being his approaching departure from the district, consequent upon his resignation of the post of medical superintendent of the Nordrach-on-Dee Sanatorium, Banchory, with which institution Dr. Lucas has been associated for the past twelve years. Appreciative speeches were made by Professor Ashley W. Mackintosh of Aberdeen University, Lachlan Mackinnon, Esq., and Provost McIlardy of Banchory. The guest of the evening fittingly responded. On March 19th Dr. Lucas was the recipient of a handsome canteen of silver as a token of esteem and gratitude from his patients at Nordrach-on-Dee.

Scotland.

SCOTTISH BOARD OF HEALTH.

DR. NORMAN WALKER, Edinburgh, has been appointed chairman of the Scottish Board of Health Consultative Council on Medical and Allied Services, in succession to Principal Sir Donald MacAlister, K.C.B., and Dr. John Yule Mackay, Principal of University College, Dundee, has been appointed vice-chairman, in succession to Dr. Walker. While relinquishing the chairmanship of the council, Sir Donald MacAlister will continue to give his services as a member of the council.

THE CAMERON PRIZE.

At a meeting of the University Court of the University of Edinburgh on March 14th, with Principal Sir Alfred Ewing in the chair, it was reported that the Senatus had awarded the Cameron Prize for 1921 to M. Jules Jean Baptiste Vincent Bordet, Director of the Pasteur Institute, Brussels.

THE EDINBURGH TUBERCULOSIS TRUST.

The report presented to the annual general meeting of the Royal Victoria Tuberculosis Trust in Edinburgh stated that the work of establishing a sanatorium colony at Southfield, in the parish of Liberton, was making good progress. The site is within a short distance of Edinburgh and not far from the new chemical laboratories of the University. Sir Robert Philip expressed the hope that the new colony, while affording opportunities for controlling observation, investigation, and research, would result in important contributions to the knowledge of tuberculosis and the most effective means of treating it. Recently persons concerned in the treatment of tuberculosis had been bombarded by inquiries about the Spahlinger treatment, and he had himself received one night a long cablegram from a colonial Government asking what steps should be taken to obtain the benefits of the treatment for patients in the colony. Such an incident and the excitement generally meant hopeless ignorance as to tuberculosis; it was an infectious disease, which took a long time to come, a long time to go, and for which there was no magical cure. The Edinburgh Tuberculosis Trust sought to educate the public, and by establishing a chair of tuberculosis in the University of Edinburgh was endeavouring to ensure that every student of medicine received a thorough training in the subject. The search for a cure would continue, but the public should look with caution on novelties for which more was often claimed than could be fulfilled.

Ireland.

WOUNDED IN HOSPITAL.

In connexion with the representations recently forwarded to the President and Council of the Royal College of Surgeons in Ireland regarding fellows and licentiates of the Royal College and other members of the profession in Ireland affected by the military Order requiring them to furnish daily particulars of wounded persons under their care in hospital, Sir William Wheeler, Vice-President, in the absence, owing to illness, of the President, Mr. E. H. Taylor, has forwarded to the Irish Medical Secretary a copy of the following resolution adopted by the Council of the Royal College of Surgeons in Ireland:

The Council are of opinion that it is contrary to the public interest that medical men should break their professional tradition and, without the consent of their patients, disclose information which they have obtained in the discharge of their professional duties. If any instance is reported to the Council in which one of the fellows or licentiates of the College is pressed to break confidence, such specific case will be considered by the Council, and representations made to the authorities if such be thought necessary.

The pronouncement contained in this resolution will be much appreciated by the profession generally, as there were many professional objections against compliance with the military Order. If the Order were carried out by the profession in Ireland, it would mean that wounded members of the Irish republican army would be disposed rather to die from their wounds than seek medical aid,

when doing so meant for a certainty their trial at a later date by the military authority. This aspect of the working of the military Order caused medical men in Ireland much anxiety, as in practice it would mean the denial of medical aid to the wounded.

POOR LAW MEDICAL OFFICERS' SALARIES.

The Council of the Royal College of Surgeons in Ireland has also had under consideration the non-payment of the salaries of Poor Law medical officers in the circumstances stated in this column on February 26th, 1921 (p. 319). The Council appointed Sir William Wheeler, Vice-President of the College, to interview the Local Government Board (Ireland), with the result that he has received from the Vice-President (Sir Henry Robinson) of that body the following letter:

Dear Sir William Wheeler,

In accordance with my promise I write to let you know that the draft Order in Council, which I read to you when you called here yesterday, has been approved by the Privy Council and the order made.

The Order will empower the Local Government Board to authorize boards of guardians and district councils to pay interest on overdrafts which they may require to enable them to meet salaries of medical officers and other urgent payments until they obtain the requisite funds for the purpose from the county councils.

Yours sincerely,
(Sgd.) H. A. ROBINSON.

The Order referred to will not meet the case of the Poor Law medical officers including those retired on pension. The main obstacle to the payment of the salaries of Poor Law medical officers and the pensions of retired Poor Law medical officers is the Malicious Injuries Amendment Act, 1919, and the Restoration of Order in Ireland Act, 1920. These Acts provide that all grants for health and other local administration, as well as all moneys raised through the local rates, are to be set aside to meet awards made for malicious injuries, including those committed by the Crown forces. In connexion with these malicious injuries, Mr. Justice Pim, in his recent address to the Queen's County grand jury, said:

"As to the destruction of property by so-called reprisals, it was a matter for suggestion that it should not be put on the county, but where the destruction was caused by Irishmen it was right Irishmen should bear the burden. It would all end in no county being able to bear what the law would put on."

The last sentence quoted from Mr. Justice Pim's address describes what has happened in the majority of Irish counties; they are not able to meet the burden put on them by recent legislation. The entire machinery of local government administration in Ireland is at present employed, in the first instance, on the collection of the awards for malicious injuries. The result is that the health services are not administered; they are practically suspended, except so far as the local doctors in their charity afford gratuitous attendance to the necessitous poor. Numerous complaints are made that poor persons are dying from want of sufficient medical attendance and medicine. The local authorities, however, disclaim all responsibility; they point out that they have made provision in their rate estimates for this year for the carrying on of health administration and other essential services, but that all the efforts of the Government are directed to compelling the local authorities to continue to lodge their funds with banks as treasurers for the purpose of meeting the awards for malicious injuries by whomsoever committed. The complaint of the Poor Law medical officers and other medical officials, whose salaries are paid out of the rates and public grants, is that recent legislation, in connexion with the disturbed conditions in Ireland, should provide for the seizure of their well-earned salaries and their diversion to meet the awards for malicious injuries. Moreover, the amended statutes, which in their application have inflicted such hardships on the Poor Law medical officers and the necessitous poor for whose treatment they were responsible, made special provision that certain public funds set aside in aid of land purchase should be exempted and expended as heretofore. When this legislation was being enacted there were stronger reasons why the public grants and other moneys for Irish health services should be similarly safeguarded, if only in respect for the Red Cross. It is only right to state that the permanent officials of the Irish Local Government Board are not responsible for the present condition of the Irish health services. That Board

had no choice but to administer the local government statutes as they left Westminster. The Chief Secretary for Ireland is the President of the Irish Local Government Board as well as Minister of Health for Ireland. In his dual capacity the Irish medical profession have appealed to him, and based their case more on the grounds of suffering humanity than on their own personal interests. Notwithstanding this appeal the Chief Secretary's attitude is unaltered. The position is this, that fully 30 per cent. of the necessitous Irish people are left by the Government absolutely unprovided for as regards medical treatment and medicine. Such a state of affairs could not have arisen had a Ministry of Health been established in Ireland on the same lines as in England and Scotland.

Correspondence.

PAST APPEARANCES OF ENCEPHALITIS LETHARGICA.

SIR,—So much publicity has naturally been achieved by the recent memorandum of the Ministry of Health on "Encephalitis Lethargica" (Memo. 45 Med.), that it seems desirable that attention should be drawn to the extraordinary inaccuracy of the paragraph thereof which bears the above heading.

1. Willis died in 1675. The allusion, therefore, to a "strange fever" arising in 1685, and described by him, seems "obscure." In 1918 I identified Willis's "epidemic leavour" of 1661 as a myoclonic form of "encephalitis lethargica"; Dr. Hamer has identified the "strange fever" of 1658 (following the influenza of that year) as cerebro-spinal meningitis.

2. The "epidemic of somnolence with associated nervous symptoms" recorded by Camerarius in 1712, appears to relate to the account by R. J. Kammermeister of an epidemic febrile catarrh in 1712 that has been hitherto regarded as influenza by every epidemiographer, and which was influenza without doubt. As Kammermeister himself said, during this epidemic, he saw few people who were sleepy *unless they had opium*. It is to von Economo that must be attached the responsibility for the suggestion that in 1712 one Camerarius described what we now call encephalitis lethargica, as a clinical entity distinct from influenza. In 1729, however, Elias Kammermeister described admirably, as arising during an epidemic of what we now call influenza, an outbreak of myoclonic disease indistinguishable from what is now called encephalitis myoclonica.

3. It is difficult to say what epidemic is indicated by the reference to "Lepecq de la Clôture (1768)," but a careful perusal of the works of the author indicated has failed to satisfy me that, during the "grippe" observed by him in 1768, he noted cases that were "encephalitis lethargica" rather than cerebro-spinal meningitis.

4. By "Ozanam" the Ministry apparently intends reference to Ozanam, the celebrated French epidemiologist, who described much of our modern "influenza" as *fièvre catarrhale*, and so forth. The German prevalences of 1745, the Lyonnais prevalence of 1800, and the Milanese affair of 1802, are all accepted nowadays as parts of the "influenzas" of those years, which he recorded at second-hand.

These facts render even more strange than otherwise would be the case, the statement of the Ministry (loc. cit., p. 8) that no direct relation between encephalitis lethargica and influenza has been established, and the earlier statement of the Ministry's chief medical officer (Annual Report, 1919-20, p. 48) that the pandemic of influenza of 1918-19 was accompanied, *in point of time merely*, by encephalitis lethargica in various parts of the world. Since a relation in space is not denied, it is difficult to see what other relation than one in time could be expected. What relations other than those of space and time does the Ministry hope to establish by way of "epidemiological connexion"?

As a matter of fact, complete demonstration has been given by me that, during 450 years at least, outbreaks of "epidemic encephalo-myelitis" in many clinical and epidemiological forms have invariably appeared in definite relation to epidemics of influenza.

The demonstration of this fact constitutes practically the only recent advance in our comprehension of influenza; and it is of cardinal importance, for it affords us a means

of foreknowledge of the outbreak of influenza on the grand scale. This was first shown in the Chadwick Lectures for 1918, and later in a paper which was published in the *Proceedings of the Royal Society of Medicine* (Section of History of Medicine) during 1919, and has since been reprinted both at home and abroad and largely copied.

There is no excuse for the appearance in an official memorandum of the inaccurate and loose "historical" references to which I have alluded, for the real historical facts were given in this paper and could have been easily verified.—I am, etc.,

London, W., March 16th.

F. G. CROOKSHANK.

ASTHMA AND ANAPHYLAXIS.

SIR,—Before accepting Mr. Frank Coke's teaching on anaphylaxis as the explanation of asthma (*BRITISH MEDICAL JOURNAL*, March 12th, 1921, p. 372) we must ask if it accounts for all the facts and whether it does not suggest a less complex line of treatment. In the typical picture of anaphylaxis experimentally induced the animal "becomes restless, scratches its muzzle as if irritated; respiration is quickened, then difficult; vomiting takes place, especially in dogs; there is diarrhoea with discharge of blood; micturition occurs; tetanic spasms and somersaults give place to paralysis and collapse; cessation of breathing brings death. There is marked eosinophilia and other blood changes." Of this picture the vomiting and diarrhoea occasionally occur in asthma; the difficult respiration and eosinophilia are regular characteristics. Therefore for asthma anaphylaxis is of interest pathologically, and the results recorded by Mr. Coke show that there is value therapeutically. In short, there is clear evidence of an upset metabolism in asthma; this I have repeatedly tried to point out.

But cannot we go further back, and get to something simpler than anaphylaxis, and especially to something simpler in treatment? The extreme sensitiveness displayed by these patients to minute doses of hundreds of substances harmless to ordinary individuals indicates an extraordinarily unstable metabolism. How is this instability brought about? Is it not likely that it is brought about in a large number of the 50 per cent. who exhibit anaphylaxis in the same way as in the 50 per cent. asthmatics in whom Mr. Coke has been unable to demonstrate anaphylaxis? There is much clinical evidence, supported by therapeutic success, to show that excess of energy food in proportion to energy expended is at the bottom of the condition—be it symptom or disease—called asthma. The mucous membranes become water-laden, plethoric, so that there arise the catarrhal conditions so frequent in children, catarrh of the bronchial tree manifested as recurrent bronchitis; similarly arises catarrh of the skin—eczema. The carbohydrate excess seems to interfere with protein metabolism, and so toxæmia results; to this the intestinal condition contributes. By regulating diet and exercise on these lines we can get the patient cured—to stay cured—in about 70 per cent. of uncomplicated cases.

Again, asthmatic attacks are most frequent between 2 and 4 a.m., and in working men are remarkably common on Sundays and Mondays—week-end asthma. This periodicity there is no gainsaying; and if there is one striking feature about anaphylaxis it is not periodicity.

Yet again, take these five cases from a list of over 600. They are chosen merely because they are all the cases that have come to me since October from the demobilized army, and because the lesson to be drawn is so plain that any one may read.

A., aged 23 (seen in October). Asthma twenty years, except when in the army (three years) and prior to that when at an English boarding-school (two years) where the life was similar in respect of exercise and diet to that in the army. Asthma recurred some months after return to civil life, but has much improved on following proper lines as to diet and exercise.

B., aged 25 (seen August 8th, 1920). Asthma for lifetime, except in the army (four years), and prior to that in English boarding-school (four years). Demobilized eighteen months; first attack March, 1920, then almost weekly, at week-ends. Has remained well since treatment. (A cousin of this man, aged 28, had a very similar history, with the addition of paroxysmal sneezing, the attacks being latterly of markedly week-end type. She became well on turning postwoman during the war.)

C., aged 27 (seen in October, 1920). Asthma twenty-two years, except in the army while in the infantry. On getting a commission and a "soft job" he had recurrence. Reports now "very well, have had no attacks."

D., aged 24 seen in October, 1920). Asthma twenty-two years, except in the army three and a half years; and once just after armistice. Three months well after demobilization, then recurrence, chiefly at week-ends. Asthma now much better, but there are still occasional attacks.

E., aged 32 seen March 8th, 1921). Asthma six years that is, two years before entering army. None while in army (three years; fortnightly since mostly week-end; Mondays and Tuesdays off work).

These cases will all get well and remain well as long as they properly apportion diet and exercise, especially open-air exercise, and take care as to the cooking and eating of their food. If comment is necessary, it is contained in the story of the following case:

A Salvation Army officer, aged 47, was sent to me in July, 1916. Asthma thirty years, except seven out of eleven years in Canada. While there he visited an Indian location. An old squaw said to him, "You breathe heavy." "Yes; I have asthma." "Ah, you English eat too much." "What would you have me do?" She held up two fingers. "Two days no eating." As before his telling me this story I had advised a weekly fasting day, he was so struck by the advice that he followed it. He came to see me in June, 1920, and said, "I've not been out of bed one night for three years; for two years while in France I had no asthma, though I slept in the open in the wet and mud. I can bring on asthma by an indiscretion in diet, and as I'm travelling about the world living mostly in hotels I cannot control my diet, but just leave certain things alone"—mainly a matter of cookery—"but I fast on Fridays and stick to my weekly blue pill."

Similar cases, multiplied to weariness, could be adduced from civil life, all pointing the same lesson. What is wanted is research as to the metabolism in asthma, such research as has been carried out, especially in America, as regards kidney conditions and glycosuria, and probably no disease would prove more illuminating on many problems in metabolism.—I am, etc.,

JAMES ADAM, M.A., M.D.,

Surgeon for Diseases of Ear, Nose and Throat,
Royal Infirmary, Glasgow.

March 18th.

THE CURE OF HAEMORRHOIDS WITHOUT OPERATION.

SIR,—In the interesting correspondence on this subject I have as yet seen no mention of the curative properties of electricity. Many patients fear operation or cannot, for reasons of general health, undergo either operation or any procedure involving pain. Every electro-therapist sees so many patients who exclaim, "Why did no one tell me of this method of treatment years ago?" that they are only beginning to realize how little it is known by the profession at large.

Patients who have suffered for ten and sixteen years with constant bleeding, with pain which is rarely absent, are, after ten to twenty applications of the local high frequency current, relieved of pain and bleeding. Where pruritus and eczema accompany the haemorrhoids the relief in the majority of the cases is almost magical; a week of daily ten-minute treatments giving more progress than months—in some cases years—of ointments and lotions. At the same time the patient remarks that the treatment has a very tonic effect upon the general health, so that the termination of the period of treatment is regretted. Any remaining piles can be dealt with by electrolysis, which is painful, probably as much so as the method of injection.

I feel that an apology is due for taking up your valuable space by the mention of a matter so well known to all electro-therapists, but the fact that several practitioners have told me that they had never heard of this method of treatment must be my excuse.—I am, etc.,

London, W., March 12th.

AGNES SAVILL, M.D.

PUERPERAL INFECTION.

SIR,—I have been much interested and rather amused at the many articles on this subject wherein our learned professors give most elaborate advice, etc., as to the manner in which the medical man should clothe and disinfect himself when attending a midwifery case, but they fail to state that the majority of cases of puerperal infection are due to bad nursing and dirty habits on the part of certain so-called monthly nurses (Mother Gamps), and whom the medical attendant scarcely ever appears to trouble about after having performed what he considers to be his own part of the work, and leaving the house when everything appears to be satisfactory, not waiting to

see if the patient is properly washed and that all dirty clothing and slaps are at once removed from the bedroom.

How is it that some medical men have more cases of puerperal fever in their practices than others, although most careful about disinfecting themselves, etc.? I have ventured to supply the answer. I have seen nurses throw dirty diapers under the bed of the patient, also the chamber filled with discharges, etc., and who did not intend removing them for some hours after unless forced to do so. I have known a nurse, after disinfectants had been previously used, pour water into a lately used chamber pot in order to wash the patient's private parts, and when remonstrated with, reply, "Oh, I have been a nurse for many years, have attended the best families, and you are the only doctor who has ever told me it was wrong."

As a medical man who has attended many cases of midwifery, I would venture to suggest the following simple recommendations, but which, of course, would not be applicable to either trained nurses or those who understand the importance of sanitary conditions, namely:

1. Do not leave the patient for at least half an hour after the placenta has been removed, and see that the nurse uses a proper vessel containing the clean water with disinfectants to wash the perineum, etc.

2. If the nurse is a novice at the work, do it yourself and show her the correct way.

3. See that all soiled clothes, diapers, and slaps are immediately removed from the bedroom and do not allow them to be thrown under the bed, only to be removed later on (a very common occurrence). There is very little fear of puerperal fever if these instructions are thoroughly carried out and the medical attendant takes the necessary antiseptic precautions about himself.—I am, etc.,

Bristol, March 16th.

W. HOWARD CORY, M.R.C.S.Eng.

THE CONTROL OF BILHARZIA: DESTRUCTION OF MOLLUSCS.

SIR,—It has been suggested that wild birds should be employed to lessen the incidence of bilharzia infection, because they are known to feed on fresh-water snails. The Public Health Department was recently considering the desirability of introducing otters into the stream at Pine-town, Natal, for a similar reason. The destruction of these species of fresh-water snail which harbour schistosomes, more especially *Physopsis africana*, *Linnæa natalensis*, *Planorbis Pfeifferi*, *Isidora forskali*, *Isidora tropica*, *Isidora schackoi* and *Mulinæ capensis* should certainly be attempted in those places which show evidences of stream pollution; but to eradicate fresh water snails from any country would seriously disturb the balance of nature in many regions because of the number of organisms that depend upon the snail for food. Our attention should rather be directed to those places where artificial dams have tended to increase the number of fresh-water snails and other evidences of stream pollution. A few domesticated duck will soon rid such artificial collections of water from fresh-water snails. A pool at Sydenham, from which I used to collect hundreds of infested snails in 1919, has been kept free from them for twelve months, as a result of the Indian to whom the pool belongs introducing three domesticated ducks on my advice. Besides *S. bovis*, some of the schistosomes that infest these snails probably infest animals, and the introduction of water animals is only likely to increase the number of infested snails. Domesticated duck soon eat up all the snails without introducing others to take their place; but, in providing snails as food for wild-bird life, nature has safeguarded the extermination of the snails by providing that, when visiting a pool in search of snails for food, the wild birds should carry in the clay attached to their claws minute snails and snails' eggs. Wild birds thus assist in the spread of bilharzia infection.—I am, etc.,

Durban, Natal, Feb. 17th.

F. G. Cawston, M.D. Cantab.

BIBLIOGRAPHICAL REFERENCES.

SIR,—In the JOURNAL of March 19th Dr. W. C. Rivers criticizes my book on *Pulmonary Tuberculosis in General Practice* (Cassell and Co., 1916), on the ground that one-third of the bibliography refers to the writings of Scotsmen—an offence in itself—and that there are no references to original German or Austrian papers. In attributing these

blemishes to political and geographical prejudice he is right, but in ascribing these prejudices to me he is wrong. As stated in the preface, the book was written during 1914-15 in a warship. This ship was cruising between Sierra Leone and the mouth of the Amazon, and in that part of the South Atlantic Ocean there are no reference libraries, this being a deplorable fact for which I am in no way responsible. Had there been access to a library I would have quoted in certain instances the original German authorities. On the other hand, the book makes no pretence to be a compilation of the writings of others, and as there are only fifty-five references in a work of over 100,000 words, the proportion of Scotsmen quoted should cause no undue anxiety.—I am, etc.,

London, S.W., March 19th.

HALLIDAY SUTHERLAND.

IRRITABLE BLADDER.

SIR,—Many learned and interesting papers have appeared lately on retention of urine arising from prostatic hypertrophy with residual urine. But for every one such case that a practitioner is consulted about, there are at least twenty who ask his advice on irritable bladder where there is no question of residual urine, only a feeling that when the desire comes to micturate the patient must at once do so or wet himself, and then he passes about six ounces only. These cases are most troublesome at night, and afflict most men of over 60 or 65. Women are not exempt, as most old ladies say they have to get up at night two or three times. Cold, various beverages, such as tea and coffee, alcohol in all forms, but especially spirits, increase the discomfort. In the majority of cases I cannot find anything in the urine to account for the trouble.

I can find no help in treatment from the published textbooks; in fact, I cannot see anything new stated from what was taught half a century ago; therefore I appeal to specialists and fellow practitioners to aid me if they can.

I do not think the prostate has much to do with the trouble, otherwise why should females suffer? I inquired last week of an old patient who had had the prostate removed about ten years ago—a very successful operation, in so far that he can urinate freely and retain the urine about four hours in the daytime; but he informs me he has to get up to pass water two or three times a night.—I am, etc.,

London, S.W., March 20th.

JAMES HAMILTON, M.B.

ANGIO-NEUROTIC OEDEMA.

SIR,—I have read with great interest Dr. Truman's communication on angio-neurotic oedema, published in the BRITISH MEDICAL JOURNAL of January 15th, 1921.

In the JOURNAL of April 3rd, 1915, to which Dr. Truman refers, I gave notes of two cases of the disease, in one of which I was the sufferer. I have not been able to follow up the other case, as the patient left British Honduras for England soon after my article was published. I have, however, heard that he suffered from repeated attacks of the complaint, and that he was strongly advised by the doctors in England not to return to the colony. He subsequently died in England, but I have not been able to ascertain the cause of his death.

My own case, which was a very severe and typical attack, I have no doubt whatsoever was brought about by several factors, all acting together and at the same time. For two weeks I was camping in the forest exposed to rain and sun, with insufficient and poor food, and subjected to innumerable bites from mosquitos, ticks, sand-flies, and a species of the Tabanidae family, whose bite was particularly bad, producing great local inflammatory swelling and oedema. The climax, however, was reached in my return journey when I passed a night in a "bush" house. Here I was at the mercy of thousands of bed-bugs, and these pests attacked me so fiercely and in such numbers that sleep was absolutely out of the question. A few days after my return to comfort and civilization I experienced my first and only attack of angio-neurotic oedema.

I most sincerely hope that Dr. Truman may be mistaken in his view that the disease always returns. My one and only attack was in the year 1913, and up to the present

time I have been free. The disease is uncommon in the colony, and I have seen no other cases.—I am, etc.,

F. L. DAVIS, M.R.C.S.

Corozal, British Honduras, February 18th.

SPINA BIFIDA.

SIR,—Mr. Cokkinis, in your issue of March 12th, records an unusual case of myelocoele, and in the concluding paragraph of his communication states that an exceptionally busy practitioner has had but two cases of spina bifida in thirty years.

In these circumstances it may be of interest to record that between November 19th, 1919, and February 25th, 1921, I have had 4 cases of spina bifida occurring in about 100 midwifery cases; 3 of them were born dead, the other lived for two months.—I am, etc.,

R. P. SMALLWOOD, M.B., B.Ch., Cantab.

Little Waltham, Chelmsford, March 14th.

Universities and Colleges.

UNIVERSITY OF OXFORD.

Radcliffe Travelling Fellowship.—The Master and Fellows of University College announce that the Radcliffe Trustees have elected Tom Sydney Nelson, M.A., B.M., University College, to a Radcliffe Travelling Fellowship of £200 for three years.

Radcliffe Prize.—The Master and Fellows of University College have awarded a Radcliffe Prize of £50 to Edward Palmer Poulton, M.A., D.M., F.R.C.P., Balliol College, for his researches in Physiology and Pathology.

UNIVERSITY OF CAMBRIDGE.

The degree of Doctor of Laws *honoris causa* will be conferred upon H.R.H. the Prince of Wales on May 31st.

The election to the Sir William Dunn Professorship of Biochemistry will be held on April 19th.

The General Board of Studies has recommended the appointment for five years of a University Lecturer in Physics as applied to Medical Radiology in connexion with the Special Board for Medicine.

At a congregation held on March 11th the following medical degrees were conferred:

M.D.—Geoffrey Evans, R. R. Walker.

M.B., B.Ch.—E. P. Brockman.

M.B.—R. K. Merson.

Applications for the John Lucas Walker Studentship in Pathology must reach the Professor of Pathology, at the Pathological Laboratory, before April 5th.

UNIVERSITY OF LONDON.

The University of London Physiological Laboratory.

As announced last week, the Senate has reconsidered its decision of December 15th last to close the Physiological Laboratory of the University at the end of July. At the meeting of March 16th a resolution was adopted to continue the laboratory until the end of the current triennium—that is to say, until the end of 1923.

At a meeting on March 15th the Faculty of Medicine adopted two resolutions: the first stated the Faculty's opinion that the closure of the Physiological Laboratory, South Kensington, would be a grave injury to the advancement of science, and the second affirmed that it was highly desirable to continue the work of the Physiological Laboratory in its present situation on its pre-war condition until at least equivalent facilities can be provided elsewhere, as forming a valuable part of the work of the University.

QUEEN'S UNIVERSITY, BELFAST.

At the graduation ceremony held on March 19th the following degrees were conferred:

M.D.—J. Donnelly, F. Hopkins.

M.B., B.Ch., B.A.O.—J. A. Smyth, Eileen O. Bartley, S. A. Thompson, J. Black, S. M. Bolton, J. W. Bradbury, Henrietta Bradshaw, P. P. Connolly, M. Emery, J. English, J. Gaussen, E. M. Hadden, H. Harris, S. M. Kirk, D. Loughbridge, R. J. McMullan, B. McNeill, A. McSparran, E. C. Patterson, J. Patton, J. D. Reynolds, W. J. Simpson, A. C. Sinclair, Kathleen R. Snodgrass, J. Young.

D.P.H.—J. M. C'earkuin, J. H. Davison, J. W. Kernohan, Olga R. I. Love, J. A. Martin, G. Patton, W. Saunderson, R. L. Sinclair, S. J. Stewart.

* First-class honours. † Second-class honours.

ROYAL COLLEGE OF SURGEONS OF ENGLAND.

Nominations for Councillors.

Monday, March 21st, was the last day on which the names of candidates for the elections for members of Council on July 7th were to be received. No fewer than eleven nominations have been received. Of the four retiring candidates, Sir George Makins and Mr. Ernest Lane will not seek re-election. On the other hand, Mr. Waring, of St. Bartholomew's Hospital, Fellow 1891, Member 1890, and Mr. F. F. Burghard, C.B.,

Fellow 1889, Member 1886, will once more offer their services to the Council. The new applicants are: Mr. W. Thelwall Thomas, M.B.E., of Liverpool, Fellow 1890, Member 1886; Mr. A. H. Cheate of King's College Hospital, Fellow 1892, Member 1888; Mr. J. H. Fisher, St. Thomas's, Fellow 1893, Member 1891; Mr. W. Turner, Westminster, Fellow 1895, Member 1893; Mr. C. H. Fage, Guy's, Fellow 1893, Member 1896; Dr. Victor Bonney, Middlesex, Fellow 1899, Member 1895; Mr. L. Bathe Rawling, St. Bartholomew's, Fellow 1900, Member 1896; Mr. Donald J. Armour, C.M.G., West London Hospital, Fellow 1900, Member 1897; and Mr. Russell Howard, C.B.E., London Hospital, Member and Fellow in 1903.

Obituary.

WILLIAM IRONSIDE BRUCE, M.D. ABERD.,

Physician in Charge of the X-Ray Departments, Charing Cross Hospital and the Hospital for Sick Children.

WE regret to announce that Dr. William Ironside Bruce died at his residence in London on Monday, March 21st, after a severe and distressing illness of about two months' duration. His early death has cut short a career of good service and much usefulness, and his loss will be greatly felt by many members of the medical profession, and is especially lamented by Charing Cross Hospital and its Medical School.

William Ironside Bruce was the second son of the late Dr. William Bruce of Dingwall, and a nephew of Dr. J. Mitchell Bruce, Consulting Physician to Charing Cross Hospital. His mother, who survives, was a Miss Ironside, so that he was a cousin of Major-General Sir W. E. Ironside, now on service in Mesopotamia. His family had its origin in the upland Aberdeenshire parish of Keig, in the valley of the Don, which remained remote from outside influences till comparatively recently. The lads of promise passed from the parish schools of the district to the grammar schools in Aberdeen and to the University, and it is along this well-beaten road that men with names such as Bruce, Ironside, and Robertson Nicoll have proceeded to take their place in the nation's roll of honour.

William Ironside Bruce was born at Dingwall, and was educated at various schools in the north-east of Scotland. Entering the University of Aberdeen he obtained the degrees of M.B. and Ch.B. in 1900, and then he took service as civil surgeon in the South African Field Force. During his period of service he suffered from enteric fever, the consequences of which affected his health for some time. While in South Africa he took much interest in the early application of x rays for the diagnosis of war injuries. On his return to this country he obtained the diploma of Public Health, and proceeded to the degree of M.D. of his university. Shortly afterwards it became necessary to appoint an assistant to the late Sir J. Mackenzie Davidson at Charing Cross Hospital, and Ironside Bruce was selected for this post. He remained in the service of Charing Cross Hospital to the time of his death, and gradually built up an exceedingly complete and efficient x-ray department in the hospital.

Ironsides Bruce was intensely interested in his work, in the scientific developments of his subject, and especially in its practical application to the diagnosis and treatment of disease. The whole of his later work was built on a good foundation, as is evidenced by the publication in the early part of his career of his *System of Radiography with Atlas of the Normal*. He was a good teacher, and many now engaged in the practice of radiography owe much to his instruction. Perhaps Ironside Bruce's strongest point was his desire to be of service to his professional brethren in their practice. With a very complete knowledge of his subject he had a sound and increasing acquaintance with general medicine and surgery. Anyone who had the opportunity of consulting him, either in hospital or in private practice, gained not only such knowledge as was possible by radiographic means but much sound information both as to diagnosis and treatment. In this peculiar relationship Bruce's work was of the greatest value to all his friends. In process of time he became President of the Section of Radiology in the Royal Society of Medicine, and took much interest in the establishment of the special diploma in this subject, now given by the University of Cambridge. It is only a fortnight ago that we announced his appointment to be President of the Section of Radiology and Electro-therapeutics at the forthcoming Annual Meeting of the British Medical Association at Newcastle.

For some months his colleagues had been unhappy as to the condition of his health, but his energy would not be restrained. At the beginning of the year, however, he was persuaded to stop work and take a prolonged holiday. Shortly it was found that his illness was serious. Blood examination established the diagnosis of the severest type of aplastic anaemia, and from this disease he died. The evidence now accumulating that this condition can be caused by the effects produced on the blood-forming structures of the body by the more penetrating radiations both from x-ray tubes and from radium renders it almost certain that he succumbed as the result of his continuous and enthusiastic work in the subject of his choice.

THE LATE CAPTAIN E. R. ARMSTRONG.—Major-General Sir Patrick Hehir, I.M.S. (ret.), writes: I should deem it a privilege to be allowed to add a few remarks to those made in the issue of the BRITISH MEDICAL JOURNAL of March 19th, 1921, regarding the late Captain Edward Randolph Armstrong, I.M.S., whose untimely death has deprived the Indian Medical Service of one of its most brilliant and capable officers. I knew him chiefly at Army Headquarters in India, where he was attached to the D.M.S.'s office, and did most excellent work during the war. He was very loyal to his friends and those with whom he was officially connected. He had a lovable disposition, and I personally greatly enjoyed and benefited by his friendship. It was a source of pleasure to him to be of service to others. He was very hard working, and got through an extraordinary amount of work with exceptional ease. Nothing seemed to deprive him of his calm, quiet, and unruffled demeanour; he appeared to grasp intuitively the main points of any subject he was dealing with; one looked upon his power of penetration as a remarkable gift, and found him a quick and sound thinker and rapid worker. I was principally brought into contact with him in sanitary matters, and found that he had a natural talent to get down to the first principles of questions arising and apply the remedy. He was a good mathematician. One expected him to go far, but there was always doubt as to his being able to stand the strain of the high pressure at which he worked. One of his greatest griefs was that his state of health precluded his selection for field service during the great war.

Medical News.

AT the meeting of the Section of Tropical Diseases and Parasitology of the Royal Society of Medicine on Monday, April 4th, at 8.30 p.m., papers on malaria will be read by Dr. W. Broughton-Alecock and Dr. H. C. Lacey.

THE Tuberculosis Society proposes to arrange a post-graduate course in Paris towards the end of May if a sufficient number of applications are received by Dr. W. G. Dickenson, 1, Ridley Villas, Newcastle-on-Tyne.

A SERIES of meetings for graduates, with demonstration of cases, will be held by Dr. Dingwall Fordyce in Ward 4, the Royal Liverpool Children's Hospital, Myrtle Street, at 10 a.m. on the following Saturdays: April 2nd, baby feeding and the prevention of disease; May 7th, indigestion in infancy, the wasting baby; June 4th, diet of older children, indigestion; July 2nd, dietetic treatment in illness.

AT the meeting of the Harveian Society held at the Paddington Town Hall on March 17th the Harveian Lecture was delivered by Dr. Leonard Williams on "The thymus gland in everyday life." At the close of the lecture a vote of thanks was proposed by Dr. Wilcox and seconded by Dr. Wilson.

A VERY successful reunion dinner of No. 14 General Hospital, B.E.F. (Amereux), was held on March 16th at the V.A.D. Ladies' Club, 28, Cavendish Square. Lieutenant-General Sir John Goodwin, D.G.A.M.S., a former commanding officer of the hospital, was in the chair, and proposed the only toast, "Absent Friends." Apologies for absence were read from Colonel R. J. C. Thompson, Major Colin Mackenzie, and others, and a message was sent from the reunion to Miss Fox, matron during the greater part of the hospital's existence, who was now abroad. Among those present at the large gathering were Miss Barrett, R.R.C., Miss Morris, R.R.C., and other former nursing sisters; Lady Elizabeth Keppel, the Hon. Cecilia Lawley, Miss Sloggett, and many other former members of

the V.A.D. detachment; and Lord Dawson of Penn, Colonel A. Webb-Johnson, Colonel Francis Steward, Major Hugh Thursfield, Captain Sir Joseph Skevington, Captain Ridley Mackenzie, and other former medical officers.

THE twenty-fifth anniversary of the day on which Professor Röntgen made his first communication on the discovery of x rays to the Würzburg Medical Society was recently celebrated at the Physical Institute of Würzburg University.

THE personal estate in the United Kingdom of Lieut.-General Sir William Babbie, V.C., K.C.B., K.C.M.G., was £6,807.

TWO supplementary volumes of Keen's *Surgery*, which have been in preparation since the armistice, will shortly be published by Messrs. W. B. Saunders. The first six volumes recorded the progress of surgery down to 1913; the two new volumes bring it down to 1921.

THE annual meeting of the Société française d'oto-rhino-laryngologie will be held in Paris at the Hôtel des Sciences Savantes, 8, Rue Danton, on May 9th, 1921.

THE International Congress on the History of Medicine will be held in Paris at the Faculty of Medicine from July 1st to 5th, 1921. In connexion with the Congress, a historical exhibition is being organized. Communications should be addressed to the Secretary, Dr. Laignel-Lavastine, 10, Place de Laborde, Paris.

IN January 7 cases of rabies occurred in Holland—6 in the province of Groningen and 1 in the province of Drenthe.

THE fifth Sicilian Medical Congress, consisting of three sections devoted to medicine, surgery, and professional interests respectively, will be held next month at Palermo.

THE forty-fifth meeting of the German Society of Surgery will be held in the Langenbeck-Virchow House, Berlin, from March 30th to April 2nd.

Letters, Notes, and Answers.

As, owing to printing difficulties, the JOURNAL must be sent to press earlier than hitherto, it is essential that communications intended for the current issue should be received by the first post on Tuesday, and lengthy documents on Monday.

ORIGINAL ARTICLES and LETTERS forwarded for publication are understood to be offered to the BRITISH MEDICAL JOURNAL alone unless the contrary be stated.

CORRESPONDENTS who wish notice to be taken of their communications should authenticate them with their names—of course not necessarily for publication.

AUTHORS desiring reprints of their articles published in the BRITISH MEDICAL JOURNAL are requested to communicate with the Office, 429, Strand, W.C.2, on receipt of proof.

IN order to avoid delay, it is particularly requested that ALL letters on the editorial business of the JOURNAL be addressed to the Editor at the Office of the JOURNAL.

THE postal address of the BRITISH MEDICAL ASSOCIATION and BRITISH MEDICAL JOURNAL is 429, Strand, London, W.C.2. The telegraphic addresses are:

1. EDITOR of the BRITISH MEDICAL JOURNAL, *Aitology*, Westrand, London; telephone, 2630, Gerrard.
2. FINANCIAL SECRETARY AND BUSINESS MANAGER (Advertisements, etc.), *Articulate*, Westrand, London; telephone, 2630, Gerrard.
3. MEDICAL SECRETARY, *Medisera*, Westrand, London; telephone, 2630, Gerrard. The address of the Irish Office of the British Medical Association is 16, South Frederick Street, Dublin (telegrams: *Bacillus, Dublin*; telephone, 4737, Dublin), and of the Scottish Office, 6, Rutland Square, Edinburgh (telegrams: *Associate, Edinburgh*; telephone, 4361, Central).

QUERIES AND ANSWERS.

"J. T." asks for light on the nature of the aches commonly called rheumatism, chronic rheumatism, or muscular rheumatism, and often associated with a coming change in the weather.

PROLONGED ADMINISTRATION OF ARSENIC.

"L. H." asks whether there is any rule guiding the long administration of arsenic. Could the drug be safely given fairly regularly over a period of three years in a case of psoriasis, which it greatly benefits?

INCOME TAX.

"N. R. W.," who contemplates retiring to England from the Colonies, inquires what tax he would pay on "a private income of over £2,000"?

* * Our correspondent would pay as income tax nothing on £135 (or on £225 if married), 3s. on £225 and 6s. on the remainder—less appreciable allowances for children under 16 years of age and for payment of life assurance premiums. He would also be liable to pay supertax at 1s. 6d. in the £ on the excess of his income over £2,000.

"G. P." intends to relinquish his practice, owing to illness and to commence a small consulting practice in the neighbourhood. He asks, "If the expenses exceeded the gross earnings, could the loss be set against the private income?"

* * Yes; but if that is done the amount of the loss cannot be carried forward as a minus quantity for the average of future years. We may add that "G. P." might anticipate some difficulty with the authorities over his expenses—for example, the total cost of car and chauffeur might be objected to if infrequently used for the practice.

"ANOTHER R.M.O." receives "a salary of £350 plus £150 in lieu of board and lodging." He asks if the £150 is assessable.

* * Yes—as our correspondent does not receive "in kind" but in cash. The principle is that something received for services rendered is assessable if it is money or something capable of being converted into money.

"A. K." pays interest on a bank overdraft. He asks whether he can deduct the amount in arriving at his total income.

* * In our opinion, yes, provided of course that the amount has not been treated as a professional expense, in which case the deduction has already been effected in that the amount assessable has been reduced. Perhaps our correspondent can induce the inspector of taxes to quote the precise section of the 1920-21 Finance Act on which he relies for support in refusing the claim; we cannot identify it.

LETTERS, NOTES, ETC.

ADRENALINE IN RESUSCITATION.

Dr. A. E. YOUNG (Kuruman, Bechuanaland) writes: I read with interest Mr. J. P. Lockhart-Mummery's note in your issue of January 15th, p. 100, on adrenaline in resuscitation. It has left me rather confused, as I have been taught that adrenaline with chloroform forms a poisonous compound which is liable to cause—and has caused—fatalities, and that its use during or just after chloroform anaesthesia is contra-indicated. I should be glad to learn from any of your readers whether the facts are as I have stated, or that I am under a misapprehension.

A THREE-WHEELED RUNABOUT.

THE Cambro monocoar is a runabout produced by the Central Aircraft Company (60, Chancery Lane, W.C.2) with a view to combining the comfort and protection from weather of a three-wheeled car with the simplicity and economy of a motor tricycle. The body is something of the nature of a large side-car, with a hood and a small glass screen. Behind the body and above the driving wheel is a 2 h.p. horizontal engine with twin opposed cylinders. The transmission is direct from the engine through a counter-shaft to the back wheel by chains. The engine is started by means of a foot lever. The system of springing used on the machine is new, rubber cords as in aeroplanes being utilized for absorbing road shocks. Several of these monocoars are stated to have travelled over 6,000 miles; it is said that they will average sixteen miles an hour, can do twenty-six when required, will climb any ordinary hill, and will run 100 miles on a gallon of petrol. It would seem as an additional mode of locomotion in some rural and suburban practices. It is as cheap as a motor cycle, and affords a great deal more protection from weather.

VACANCIES.

NOTIFICATIONS of offices vacant in universities, medical colleges, and of vacant resident and other appointments at hospitals, will be found at pages 34, 35, 36, and 37 of our advertisement columns, and advertisements as to partnerships, assistantships, and locum tenencies at pages 32 and 33.

SCALE OF CHARGES FOR ADVERTISEMENTS IN THE BRITISH MEDICAL JOURNAL.

	£	s.	d.
Six lines and under	0 9 0
Each additional line	0 1 6
Whole single column (three columns to page)	7 10 0
Half single column	3 15 0
Half page	10 0 0
Whole page	20 0 0

An average line contains six words.

All remittances by Post Office Orders must be made payable to the British Medical Association at the General Post Office, London. No responsibility will be accepted for any such remittance not so safeguarded.

Advertisements should be delivered, addressed to the Manager, 429, Strand, London, not later than the first post on Tuesday morning preceding publication, and, if not paid for at the time, should be accompanied by a reference.

NOTE.—It is against the rules of the Post Office to receive posts *restante* letters addressed either in initials or numbers.

A British Medical Association Lecture ON THE TREATMENT OF FRACTURES.

BY
S. ALWYN SMITH, O.B.E., D.S.O., CH.M.EDIN.,
F.R.C.S.EDIN.

SURGEON, ROYAL HAMADRYAD STAMEN'S HOSPITAL AND PRINCE
OF WALES HOSPITAL, CARDIFF; CONSULTING SURGEON,
MINISTRY OF PENSIONS, WELSH REGION.

PRIOR to the war, of the three schools of thought as to the treatment of fractures each had adherents, but the school which advised and practised operative fixation appeared to be gaining favour at the expense of the less spectacular treatments of conservative immobilization and mobilization with massage. In certain cases results by either method left much to be desired.

The diversity of opinion, and oftentimes the poor results, led the British Medical Association to appoint a committee to report on the merits and demerits of treatment by operation or by splinting.¹ One of the conclusions reached by this committee was as follows:

"For surgeons and practitioners who are unable to avail themselves of the operative method the non-operative procedures are likely to remain for some time yet the more safe and serviceable."

This conclusion obviously favoured the operative method, and the general practitioner was left in doubt whether he was justified in treating his own fractures or whether he was to hand them over to the surgeon at the nearest hospital.

During the war most members of the profession had ample opportunity of treating compound fractures, or at any rate of seeing the results of such cases treated by conservative means where this treatment was standardized according to the ideas of the Liverpool orthopaedic school, with modifications such as are exemplified by the work of Pearson, Sinclair, and others. Conservative treatment by splinting has thus again come into its own purely on account of the excellent results gained by standardized methods in thousands of gunshot compound fractures obviously unsuitable for operative fixation of fragments.

In the early days of the war some surgeons tried the effect of plating septic compound fractures, in the hope that the good effect of immobilization of the broken ends would outweigh the ill effects of interference and the inclusion of foreign material. This effort was short-lived, and rightly so, as the results were universally bad.

I mention the various methods of treatment in order to emphasize the fact that in treating fractures in civil life, which are for the most part simple fractures, we should not be hidebound adherents of a single method. Where our experience tells us that we cannot get a good functional result by splinting alone we should be prepared to operate, provided we have experience in that method also. The main essential is that, following general principles guiding treatment, we shall pay the strictest attention to detail in whatever method we adopt. I was closely associated with Sir Robert Jones for seven years, and am imbued with his principles and follow his methods, therefore I am biased towards conservatism in treatment. The advent of radiography has educated the profession as to the shortcomings of accurate fragmental apposition in conservatism, but in addition it has falsely educated the laity. Patients see their x-ray plates showing firmly united fractures in good alignment, with good functional result, but because the fragments are not meticulously apposed they deem themselves the victims of malpraxis, and strained relations may ensue. The public will in time, no doubt, become educated to the axiom that it is not possible to either guarantee accurate anatomical reposition by mechanical means or perfect function by operative methods.

The principles laid down by H. O. Thomas and Sir Robert Jones in the mechanical treatment of fractures are important and have a direct bearing on successful outcome.

1. A fracture is a potential deformity and must be regarded as such. By treatment the potentiality must be prevented from becoming a reality.

2. Strong, steady, fixed extension, with corresponding counter-extension is required as distinguished from forcible intermittent pull succeeded by a period of muscular relaxation. This principle is applicable more especially to fractures of the lower extremity, particularly the shaft of the femur. It is held that a steady traction through a Thomas bed splint, with the counter-extension of the ring of the splint against the tuber ischii, is preferable to the inclined bed and weight-and-pulley method. The latter, though theoretically constant in pull, is practically intermittent when the patient moves up and down the bed, on account of the friction of the limb against the subjacent mattress.

3. Correct alignment in conjunction with obliteration of shortening. A reduction which is incomplete at the primary operation can easily be made complete within the next few days by merely continuing and increasing the extension. The correction is brought about by fixed extension combined with appropriately fixed pads to overcome lateral deviation. This combination may also require the lower end of the fragment to be approximated to the upper by altering the position of the limb.

4. Avoid rigid circular compression which tends to produce ischaemia. In this regard the use of plaster-of-Paris as a primary dressing is dangerous except in the hands of experts. Splints should be shaped to the contour of the limb. Concavo-convex metal splints are the most favoured. They can be bent or twisted at will to produce the desired effect. They must be of greater width than the limb to be immobilized so that the circulation shall not be impeded.

5. Union may be delayed; this is sometimes unavoidable, but there is a vast difference between delayed union and non-union. When union is slow, it is of great importance to leave the limb alone and not repeatedly to move the fragments to see how things are progressing. Thomas laid down the rule that the rest must be prolonged and absolute. Idle curiosity may be instrumental in converting a delayed union into a non-union.

6. Union of a fracture does not imply its consolidation. Bones which appear firm on palpation or manual pressure will, after many weeks, yield to the body weight.

MAL-UNION AND NON-UNION.

Both mal-union and non-union are common occurrences and are often related. Angular deformities should not occur; even if we cannot produce an end-to-end apposition by traction and splinting there should be no difficulty in securing correct alignment. This is of great importance in the lower limb.

The Commonest Types of Mal-union.

In fractures of the neck of the femur the angle between neck and shaft is reduced and a condition of coxa vara results. Where the fracture is in the upper third of the shaft the upper fragment is abducted, the lower fragment pulled up to the inner side of the upper one, and a shortened bowed femur results. In fractures of the middle of the shaft there is a concavity forwards instead of the normal convexity, and genu recurvatum is afterwards found to be present. The same thing happens where the injury is in the lower fourth of the shaft. Here the upper end of the lower fragment lies behind the lower end of the upper one, and the lower fragment may even point almost directly backwards.

Fractures in the upper third of the leg may lead to a high bow leg (Fig. 1). Fractures of the middle third may result in knock-knee with either inversion or eversion of the foot, and fractures of the lower third of both bones generally end with a valgoid deformity of the foot with an internal rotation. The deformity of a malunited Pott's fracture is familiar to us all, and it is very often a shock to the surgeon who treated the case, as the deformity may arise after the patient has left his care.

Deviation from correct alignment means, in accordance with Wolff's law, alteration in structures—that is to say,



FIG. 1 High bow leg after fracture of the upper third of the femur.

¹Delivered before the East Hertfordshire Division, December 15th, 1920.

the internal architecture of the bone changes in response to new forces of strain and muscular stress that the bone itself is called upon to stand. It also means that aberrant forces are thrown on to the joints above and below, and this, combined with deviated lines of muscle pull, will result in chronic pain and discomfort, and traumatic arthritis may result. This traumatic arthritis may be the forerunner of hypertrophic rheumatoid changes in the involved joints.

Even end-to-end apposition of fragments may result in malunion where slight lateral or antero-posterior deviation causes faulty deflection of body weight.

THE COMMONEST CAUSES OF MALUNION.

I. *Being too Sparing with Traction.*

It is useless to be ladylike with a fracture in a strong muscular man, especially of femur or tibia. Traction with a pulley should be begun before the splint is applied, and we should not be satisfied until the affected side is of equal length with the other, even if continued and ever-increasing traction in the splint for a few days is found to be necessary. If the bones are of equal length there cannot be much overlap and no lateral deviation. In recent fractures of the lower extremity pulleys are rarely needed except in the very muscular. Preliminary traction by means of a roller towel clove-hitched round the limb, counter-extension being obtained by another roller towel round the perineum and fixed to the leg of the table at the head end, is generally sufficient. In cases of older standing, not firmly united, a three-ply or five-ply pulley may be requisitioned. Here the counter extension must be of stronger material. To prepare for such cases ring bolts should be let into the wall at each end of the operating room at a height of about 3 ft. Where union is complete an oblique osteotomy is performed at the site of malunion, and I am accustomed to get primary extension by means of a steel drill through the lower end of the involved bone, sterilized steel wires are attached to it, and the other ends are looped through the pulley hook.

It is surprising what strain can be obtained by this means, and I have successfully reduced a shortening of 3 in. at one sitting without damage to soft parts where the fracture was of six months' standing.

2. *Inefficient Splinting.*

The splint should allow continuous extension in the correct line for the obviation of deformity, and it should control the joint above and below the fracture. Where bones are naturally curved, as the shaft of the tibia, this curve must be imitated in fractures of both bones of the leg by laterally pulling bandages and pads. If the leg is set absolutely straight, an everted ankle and a strained internal lateral ligament of the knee will result when the patient begins to walk.

3. *The Effect of Allowing Body Weight to Fall on Recovering Bone too soon.*

An apparently sound bone may bend when the patient begins to walk, because steps are not taken to prevent faulty deflection of body weight. Textbooks are too optimistic about the period of time requisite for complete consolidation to take place. This has been shown in a series of fractured femora measured at subsequent dates after the patient had been allowed to walk. In each case a certain amount of telescoping had occurred. It is also a fact that one can frequently refracture a bone by manual manipulation after eight to twelve weeks.

For the prevention of deformity during the period of after-treatment it is necessary to take a large amount of weight-bearing strain from the fracture. It is a good working rule to fit all fractures of the femur with walking callipers for at least eight weeks after the bone is considered sound enough to let the patient up. Corresponding fractures of the upper third of the tibia should be similarly treated. Patients who have had fractures of the middle and lower thirds of both bones and Pott's fractures should be allowed to walk with a light outside iron extending from the heel of the boot to two inches below the knee-joint, and the inner side of the sole and heel of the boot should be built up a third of an inch in order to prevent the valgoid deformity that is otherwise so apt to manifest itself.

NON-UNION.

Some fractures are slower than others in beginning to unite, and here the surgeon must possess his soul in patience and leave the fracture alone. Too much interference in the way of constantly taking splints off and moving the fragments to see if union is occurring is apt to end in non-union.

Treatment by what Thomas called damming and hammering is of assistance. Passive congestion by means of rubber tubes tied above and below the fracture, sufficiently tightly to impede venous return, should be carried out for increasing periods of time every day until two to three hours is borne without undue discomfort. The ends are hammered by a small leather-covered wooden mallet twice a week to produce subperiosteal stimulation, and thus acts in the same way as the method of rubbing the ununited ends of the bone. Where non-union is definitely established, and where conservative means as outlined above have failed, the question of operation arises. In fractures of the lower extremity operation should be postponed until the effect of the patient getting about with the aid of an appliance has been tried without success. The number of stubborn non-unions that respond to this simple procedure is surprising. The need for operation having arisen, the question whether this should consist of freshening the fractured ends and bone-plating or bone-grafting is one which depends on personal choice. For myself I invariably use a bone graft; it is preferable to get the graft from the tibia rather than to use a slide inlay of the involved bone, as this is invariably posed as a result of prolonged disuse. Plating is obviously preferable to wiring for immobilizing the freshened ends where bone-grafting is not resorted to, but a circular wire loop is often of advantage where the non-union is merely due to the interposition of muscle or fascia.

If comminuted fractures appear to require operative interference, it is advisable to leave all splintered bone in position, even in the presence of sepsis. This was impressed on us all during the war. The wholesale removal of bone fragments is apt to result in non-union.

The Signs of Faulty and Delayed Union.

If there be pain over the site of a fracture of old standing, especially on digital pressure, unsound union may be suspected, and if this pain be accompanied by an exuberant callus formation the diagnosis is absolute. If malunion be present in addition, manual manipulation with the aid of a wedge will be sufficient to correct the deformity, and the irritation so caused may expedite firm union; congestion and hammering may also be used with advantage.

Operation or Splinting.

The question what fractures should be treated at once by operation, and which by splinting, must be answered by each individual surgeon according to his mechanical or operative aptitude.

I generally operate on spiral fractures of the lower third of the leg by means of inlay grafts, but plating is equally satisfactory in skilled hands. Fractures of the patella in the transverse axis I treat by wiring, as also fractures of the olecranon, where there is a large gap with rotation of the fragment. I also operate on scaphoid fractures where the proximal fragment prevents full hyper-extension of the wrist and where there is palmar dislocation of the semilunar. Removal of the proximal portion of the scaphoid is generally sufficient.

All other fractures I endeavour to treat by means of splinting or posture, or both, combined in some cases with rigid extension and counter-extension.

FRACTURES OF THE LOWER EXTREMITY.

Fractures of the neck of the femur and of the upper fourth of the shaft are best treated in the double Thomas frame with extension straps on both legs, the affected limb being widely abducted. The groin strap round the groin on the sound side gives adequate counter-extension (Fig. 2).

The exception is in cases of old people, where prolonged recumbency is contra-indicated on account of the risk of pulmonary congestion. One must judge by general appearances; the plethoric type of old age fares badly on a

frame. In these cases it is advisable to fit a walking calliper made half an inch too long and allow the patient up on crutches. The American school uses a plaster spica in wide abduction—the so-called Whitman position—instead of the Thomas frame.



FIG. 2.—Double Thomas's frame for abduction of the affected limb in fracture of the neck and upper fourth of the femur.

The question of separating impacted fractures of the neck depends on the amount of deformity; unless there is extreme rotation outwards of the whole leg the condition is best left alone in old people.

Careful nursing is essential in cases treated on a frame; the back must be carefully rubbed with talcum powder twice daily, the flat of the hand being carefully interposed between the skin of the back and the pad of the frame. An alcohol rub twice weekly

is also necessary. With these rules strictly obeyed no skin trouble need be feared.

Fractures of the middle and lower portions of the shaft of the femur, fractures of condyles, and fractures of tibial tuberosities and shaft in the upper three-fourths, are all treated in the Thomas knee-bed splint. I have heard it said by men who are not conversant with this splint that pressure sores are common with it, and for that reason they carry on with the long Liston splint. With proper nursing precautions pressure sores under the ring of the splint should be unknown, despite the tremendous pressure to which the skin in the region of the tuber ischii is subjected when heavy traction is required. Here again the skin round and under the ring must be carefully rubbed with talcum several times a day; the patient usually does it himself under supervision; rubbings with alcohol are also required to harden the skin. The skin in the region is so movable, that a fresh area can be subjected to pressure by merely pulling or pushing it under the ring; the same effect can be produced by slightly altering the position of the limb into various degrees of flexion, abduction, and adduction. Where it is difficult during the first two or three days to reduce the shortening of the limb (the dangerous period for pressure necrosis of the skin under the ring), it is advisable to tilt the foot of the bed, and fasten the lower end of the splint to the lower bars of the bed. The body weight thus keeps up and tends to increase traction, and at the same time reduces pressure on the skin of the buttock.

I use adhesive straps made of coarse holland, which I find last longer than Sinclair's glue, and I do not bend the splint either at the knee or at the site of fracture in

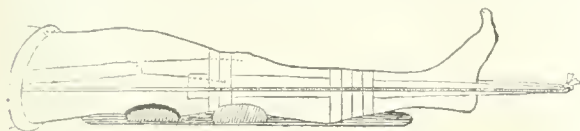

FIG. 3.—Use of malleable iron posterior splint in fracture of the middle third of the femur.

femoral cases. To preserve the antero-posterior convexity of the femur and to prevent hyperextension of the knee I use big pads interposed between the leg and the malleable iron splint which is slung beneath. This fracture-splint should run from a point two inches below the gluteal fold to the lower third of the leg (Fig. 3).

In fractures of the lower third of the femur a big pad is required beneath the site of fracture; if despite firm traction the backward distortion of the lower fragment remains, it may be necessary to divide the tendo Achillis; this, however, is very seldom required. Angulation is prevented by the application of laterally applied bandages fixed to the side bar of the bed-splint.

The use of callipers, ice tongs and Steinmann's pins to produce traction are complications which are only applicable in hospital and in the hands of experts, and in a large percentage of cases are unnecessary.

Fractures of the tibia, with the exception of Pott's fracture, are treated on the same lines, and fractures involving the knee-joint require adequate restoration of fragments by manual pressure combined with traction. The fragments are easily controlled by a broad ring of adhesive strapping around the leg.

The reduction of a Pott's fracture is of greater importance than the splinting. forcible traction with the foot in extreme extension combined with a downward pull on the leg and an upward pull on the heel to reduce the backward displacement of the foot should reduce the deformity, but occasionally it is necessary to divide the tendo Achillis. The foot is then forcibly inverted into an over-corrected position. Side splints of metal extending from the knee-joint, the outer one projecting three inches beyond the heel, are suitably padded to keep up the inversion and bandaged into position. The projecting portion of the outer splint is now bent inwards to meet the inferior extremity of the inner splint. A box is thus formed which, when duly bandaged, keeps the foot at a right angle and prevents the dropping back of the heel. In fractures of the tarsus, when reduction is complete, all that is necessary is for the foot to be kept at a right angle.

FRACTURES OF THE UPPER EXTREMITY.

Fractures of the humerus in the region of the shoulder-joint, if inefficiently treated may become malunited with, as a result, limitation of abduction and external rotation. Fractures in the region of the elbow-joint are apt to result in defects of flexion and supination. Supination is often deficient in fractures of both bones of the forearm, and the deformity of a malunited Colles's fracture, with limitation of wrist movement, of pronation and supination, and of finger flexion is well known.

Fractures of the anatomical neck of the humerus are best treated by a wrist sling which allows the weight of the arm to act as an extension—a pad in the axilla to produce slight abduction of the upper arm, and an encircling bandage round arm and trunk to fix the humerus.

Separation of the upper humeral epiphysis in childhood or adolescence may produce marked abduction and external rotation of the upper fragment, which, if unreduced, will result in inability to raise the arm above the head. In treating this condition it is advisable to abduct the arm to a right angle and to rotate it outwards till the hand is level with the mouth, and to immobilize the arm in this position either by one of the humerus abduction splints or in plaster (Fig. 4). Sometimes the amount of abduction and rotation are so extreme that it is necessary to fix the arm in plaster above the head in what may be termed the "Kamerad" position.

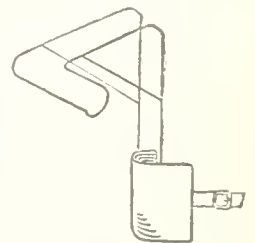

FIG. 4.—Humerus abduction splint.

Fractures of the surgical neck are often impacted, and the question of disimpaction depends on the abduction deformity of the upper extremity. Should it be found necessary, the method of Thomas (Fig. 5) is excellent. The patient is seated on a chair near the wall and a roller towel is passed under the axilla and fastened to a coat-hook or nail. A wrist sling is fastened round the neck and a clove hitch is made fast to the elbow with a long loop which comes to within a foot of the floor and which acts as a stirrup for the operator's foot. Extension is thus obtained, leaving both hands free for manipulation. The axis of the pull is brought to the abducted position, and when reduction appears complete the arm is forced upwards and reimpaeted. Treatment is now carried on as for fractures

of the anatomical neck except that a larger axillary pad is indicated.

Fractures of the shaft are treated by malleable iron fracture splints, which can be bent to cover in the shoulder-joint and thus produce fixation.

All fractures in the region of the elbow-joint, with the exception of the olecranon, are treated, after adequate and

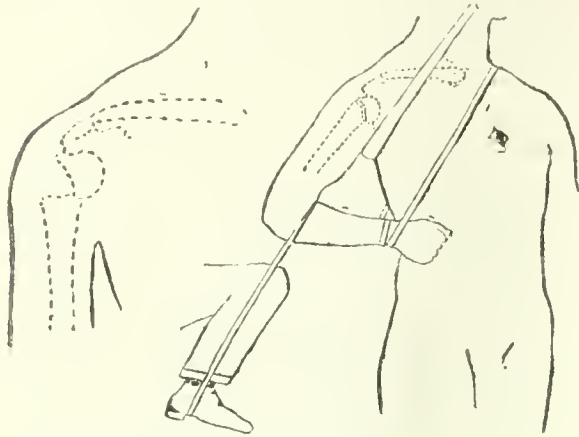

FIG. 5.—Thomas's method for reduction of impaction in fracture of the surgical neck of the humerus.

complete reduction, in the Jones or fully-flexed position. This position cannot be obtained unless reduction is complete. Whether the fracture is supracondylar, T-shaped, or intercondylar, one must reduce by traction-extension, supination, and hyperflexion, and, if the latter cannot be obtained, the routine must be repeated until it is, and the arm must then be kept in this position at rest for at least three to four weeks. A warning must be given against passive movements after the arm is being gradually brought down, otherwise traumatic arthritis and consequent stiffness of the elbow ensues. As an empiricism it is advisable to let the wrist sling down a little every week until the arm is at a right angle at the end of the sixth week. After the fourth week the patient can use the arm in the sling with moderation, and massage may be given as an adjunct to treatment, but forcible passive movement is absolutely contraindicated. For this type of fracture the rectangular internal splint should be abolished.

Fractures of the head and neck of the radius must be fixed in full supination, otherwise limitation of this movement will certainly result. Fractures of the shaft of both bones require consideration of two important points: first, the shaft of the ulna must be kept straight, and secondly, the curve of the radius must be conserved as the

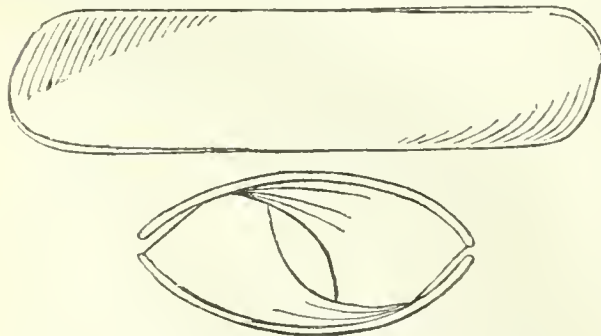

FIG. 6.—Splints twisted for the treatment of Colles's fracture.

whole length of the posterior border of the ulna is straight, and on this the curved radius rotates like a bucket handle. There must be no lateral pressure on the middle of the radius, otherwise synostosis may ensue. In the position of supination the bones are farthest from each other, and so we should treat all our shaft fractures in this position. Nearly all neglected fractures of the forearm show limitation of supination, whereas pronation is not defective.

Colles's fracture requires complete and adequate reduction before splinting takes place. The Jones method is preferable to the hand-shaking plan, because

the force is applied directly to the bone instead of working through the carpal bones. Twisted fracture splints (Fig. 6), adequately padded to keep the replaced fragments in an over-corrected position and the hand in ulnar deviation, are applied and remain for four weeks, movements of fingers and thumb being allowed from the first.

REFERENCE.

¹ BRITISH MEDICAL JOURNAL, 1912, ii, p. 1505.

Further Observations

ON

THE ETIOLOGY OF ECLAMPSIA AND THE PRE-ECLAMPTIC STATE.

BY

JAMES YOUNG, D.S.O., M.D., F.R.C.S.,

ASSISTANT PHYSICIAN, ROYAL MATERNITY HOSPITAL; TUTOR IN GYNAECOLOGY, UNIVERSITY OF EDINBURGH;

AND

DOUGLAS A. MILLER, M.B., CH.B.,

ASSISTANT TO THE PROFESSOR OF MIDWIFERY; RESEARCH SCHOLAR, UNIVERSITY OF EDINBURGH.

This paper* contains confirmation of an explanation of eclampsia which one of us published in 1914. It is based on a study, carried out at the Royal Maternity Hospital, Edinburgh, of 40 cases of toxæmia and associated conditions. The original investigations professed to show that the eclamptic and the pre-eclamptic toxæmia is dependent on a placental necrosis and they culminated in the experimental reproduction in animals of a disease closely simulating the classical picture of eclampsia. The first observations were concerned with a study of the pathology and with experiment. We propose now to give a third link of proof—the clinical.

Eclampsia and the pre-eclamptic state of toxæmia are due to the circulation in the mother's blood of a specific substance or specific substances, that have, as their dominating effects, (1) degenerative changes in the kidney and albuminuria, (2) characteristic necrotic lesions in the liver, and (3) convulsions. The symptom-pathological complex is found only in pregnancy, and it is therefore dependent, in some way or other, on the child or placenta or both, and its occurrence in cases of hydatid mole, where there is no foetus, points to the placental elements as the source of the poison.

Placental disease of the nature of infarction is common in eclampsia and pre-eclampsia. In fact, the typical case of long-standing albuminuria of pregnancy shows multiple pale areas of necrosis in the placenta. On the other hand, many cases of fulminating eclampsia show no obvious change in the placenta, and the natural inference for long was that, where infarction is present, it is only of secondary importance. If related to the toxæmic state at all—and related it must be, everyone who has studied the subject admits—it is considered as more the result of the toxæmia than the cause.

What first directed our attention to the subject was the discovery that, although obvious placental disease might be absent in the placenta of fulminating eclampsia, which ends in rapid labour or death, in the other, less virulent type, in which some days or even weeks elapse between the seizure and the birth of the placenta, there is always massive necrosis visible to the naked eye. We have seen no exception to this. Its recognition threw a flood of new light on the subject. It showed that the degenerative change is always present in the placenta, but that it requires some days before it evolves into the form of ordinary naked-eye infarction. As a matter of fact, the recognition of the real character of the change has made it possible of detection at an earlier period if it is looked for.

If these observations are correct they have a double significance. In the first place, they provide us with a tangible focus for the origin of a placental poison. If we except Veit's discarded theory of the deportation of chorionic villi into the blood stream, they offer such a focus for the first time. In the second place, they

*Read before the Section of Obstetrics and Gynaecology of the Royal Society of Medicine.

indicate that, if the necrotic areas are the source of the eclamptic poison, this poison is produced during the early autolysis of the disintegration process, and whilst the structure of the placenta shows no, or only few, visible signs of change. By the time the process has progressed to the stage of ordinary naked-eye infarction the damage has been done.

Gradual piecemeal involvement of the placenta may produce in the end an extensive infarction consisting of small isolated necrotic areas of differing ages and with no symptoms except a toxæmia, which may never at any one time be of a virulent nature, and may, in fact, escape notice. A sudden single massive placental death may, on the other hand, kill before there is even a trace of visible infarction.

At the time of our original investigations in 1914 the idea that products eliminated from the disintegration of tissues at such an early stage could be toxic was a new one in pathology. There were no analogies from other branches of medicine to guide and encourage us. That the impressions formed on the basis of our anatomical studies were, however, well founded was borne out in a very complete degree by the results of our experimental work. We showed that autolysis of the human placenta increased its toxicity to the lower animals, and, moreover, we demonstrated that the early autolytic materials are more toxic than those present later; it seemed as if the early toxic matter was labile, and, if left, became broken up into less noxious elements, perhaps as the result of the continued action of the cell-enzymes. We claimed at that time to have reproduced in the lower animals, by the injection of the early autolytic products of the placenta, a disease exhibiting the classical features of human eclampsia. At that time, as we have said, the conceptions underlying our belief were new in pathology. Since then, however, it has been recognized that similar factors operate in other diseased conditions, and so exactly have these new developments followed the lines laid down in our original investigations that they provide, by analogy, strong proof of our thesis.

We would specially direct attention to the investigations on the origin of shock (Quénu, Delbet, etc.), and more especially to the experimental reproduction of toxæmia by the injection of the products of damaged muscle. Delbet has demonstrated by an extensive and convincing series of experiments that the fission products of muscle are toxic even in the very earliest stages of disintegration. The results have been confirmed by others. A very interesting discovery made during these experiments was that the animal might die immediately or within a short time from an apparent intoxication of the nervous system. On the other hand, it might live for hours or a day or more, and then die from damage to the liver or suprarenal capsules. As Delbet says: "Ces morts retardées sont dues à des altérations du foie et des capsules surrénales." The application of these findings to eclampsia will become apparent in the latter part of this paper.

Our original investigations were arrested by the war. Since they were begun again, during the past year, we have confirmed our anatomical and experimental results. But here we desire more particularly to adduce another and different line of proof based on clinical observations. Before doing so perhaps it will be well to recapitulate briefly our previous observations on the pathology and etiology of placental infarction. Fortunately they are capable of easy demonstration.

Pathology of Infarction.

The pathological changes in an infarcted area of placenta are:

1. *Coagulation* in the intervillous spaces. This, as we shall see, is due to a blockage of the corresponding maternal vessels.

2. *Congestion* of the vessels in the foetal villi. This is early and characteristic. The expansion of the vessels causes a swelling of the villi, which become closely packed together to form a solid block resting against the decidual surface, and sharply differentiated from the surrounding spongy placental substance. This hepatization is not entirely due to the turgescence of the individual villi. It is due also, and probably largely, to the tension of the enviroing placenta which presses in on an area

in which the circulation is arrested. The infarcted block is thus really an area of collapsed placental tissue.

3. *Necrosis*.—During the necrosis the villi undergo disintegration of their cellular elements until in the end they are represented by mere ghost-like outlines. During the process the infarct passes through a series of colour changes. In the beginning it is purple or red, then it becomes chocolate-coloured, then brown, and, with the disappearance of the haemoglobin, the colour eventually of an old infarct is yellow or white. The entire evolution of change requires a considerable number of days.

The naked-eye recognition of infarction is easy when it is fully established; the pale infarct is so distinctive that it forms a prominent feature of the cut section of the placenta. The red or purple infarct is more likely to escape notice as its colour may not differ greatly from the surrounding placenta. Except in the early stages, however, it is solid, and is therefore sharply cut off from the surrounding soft and spongy placenta. In the intermediate stages an infarct may be red in one part and pale in another. In many of the early cases the infarction can only be recognized when the cut section is gently washed with running water. This rinses the intervillous blood out of the healthy parts of the placenta, which become pale, and thus bring into sharp relief the purple blocks of infarcted tissue, in which the blood is clotted and is therefore not removed by the washing.

Etiology of Infarction.

As we have shown in another communication, the underlying factor is an interference with the maternal blood supply. This may be due to simple mechanical factors—for example, *separation of the placenta from the uterus* by trauma or retroplacental bleeding. These are the circumstances that commonly accompany a case of accidental haemorrhage. Another common condition of a somewhat similar nature is *placenta praevia*, the bearing of which on the questions under discussion will be mentioned later.

In many instances there is no evidence of placental separation or of retroplacental bleeding, and the local impairment of the blood supply that ends in placental necrosis is due to *thrombosis*. We have noted this frequently, and we believe it to be an important cause of infarction.

Accidental Haemorrhage and Toxæmia.

Retroplacental haemorrhage is a common cause of placental degeneration, and it possesses a special interest for us on account of the frequency with which it is associated with toxæmia. The frequency of albuminuria in accidental haemorrhage is given by different authors in figures varying from 30 per cent. to 80 per cent. or over. Our own ratio is nineteen times in a series of twenty-one cases—that is, 90 per cent.

It is often urged that the toxæmia is the cause of the bleeding, and one can see how the discovery of the common association of the two conditions should have given rise to this belief. But we would direct notice to some considerations that bring the validity of the common interpretation under question.

I.

In the first place, accidental haemorrhage is relatively much rarer in primiparae than in multiparae, though toxæmia is specially prone to affect the former.

II.

In the second place, a study of the etiology of accidental haemorrhage shows that a severe strain or other mechanical factor may cause the condition in a woman who was apparently healthy up to that time. The importance of a purely mechanical factor is well brought out by the clinical study of our cases. In 4 out of a series of 21 cases the bleeding followed the performance of such severe exertion as the washing of clothes, or it succeeded an accident, such as falling downstairs. And in all these cases there was albuminuria. In two cases the albuminuria developed after bleeding; the importance of this will emerge later.

In most cases of accidental haemorrhage the bleeding occurs in the site of least resistance—namely, in the displacable retroplacental area. In other cases, however, the bleeding is widespread, and, coincident with the retro-

placental extravasation, there may be a deep infiltration of the muscular wall of the uterus and of the broad ligaments, a condition which has been called "diffuse utero-placental apoplexy." In our series there are two cases of this remarkable condition. In the one the extravasation involved the whole uterus and the broad ligaments on both sides. In the other the bleeding was localized chiefly at the right cornu and the adjacent part of the tube and broad ligament. The appearances are exactly those that would be produced by a sudden blockage of the right ovarian vein. The intense and sudden congestion of the uterus which is produced in these cases resembles the change induced in a pedunculated ovarian or fibromyomatous tumour by an acute torsion of its pedicle.

What is the cause of the sudden blockage of the veins in the pelvis that alone can account for a backward pressure sufficient to tear open the vessels of the uterine wall? Is it a thrombosis or a kinking, or is it due to a sudden increase of the intra-abdominal pressure?

III.

A study of the placenta in cases of accidental haemorrhage provides a third series of considerations in support of the theory which we are advocating.

Accidental haemorrhage may be divided into two classes: (a) those in which the placenta shows little or no evidence of degeneration, and (b) those in which the placenta exhibits degeneration of the detached area or areas.

(a) Here sufficient time has not been allowed for the full development of infarction. This category includes cases in which the birth of the placenta follows quickly on the onset of the bleeding, and in it are numbered most cases of external bleeding. Toxaemia is inconspicuous, and if present is represented by a slight transient albuminuria.

(b) Here the placenta throughout the detached area shows the signs of early infarction. The placenta has been retained in the uterus for some time, and, whilst the one part of the organ has remained intact and healthy, the other part has become transformed into a mass of degeneration. The degree of hepatization present is dependent on the interval that has elapsed between the local bleeding and the birth of the placenta. This observation is one which we have made so often that we have removed it from the category of the occasional or the accidental. It is invariable.

We have seen one case in which nearly half of the placenta was in a state of early purple infarction. In other cases the bleeding has taken place over small areas—the so-called "retroplacental haematomata"—and the infarcted regions are correspondingly small. Between these two extremes there are all grades in the extent of the retroplacental bleeding, and therefore in the size of the subtending areas of infarction.

Toxaemia is a dominating feature in this class of case. The most severe toxaemias in our series of retroplacental haemorrhage belong to this class. It includes five cases of eclampsia.

IV.

Finally, that the toxaemia is secondary is shown by the fact that we have actually demonstrated that it develops subsequent to the haemorrhage. In two of our cases an examination of the urine within a few hours of the bleeding was negative, whereas at a later examination an albuminuria was revealed. An albuminuria develops so rapidly after the separation of the placenta that it is usually present by the time the patient is admitted to hospital. In many cases, especially of external bleeding, the albumin may never be present except as a trace. It develops early, and in the great majority of instances it passes off early.

It will have become apparent that, if our observations are correct, in order that a toxaemia may develop it is necessary that the placenta must maintain its attachment to one part of the uterine wall. Only otherwise can it receive and pass into the maternal blood the products of the adjacent necrosis. The placenta is like a large bag, in which there is a free circulation of blood, and a necrotic area is thus like a poison-laden mass introduced directly into the maternal vessels.

A recognition of this fact accounts for the well known clinical observation that the toxaemia often ceases with the intrauterine death of the child and the complete separation of the placenta.

A suggestive analogy to the conditions which obtain in placental degeneration is supplied by the observations of Quénu in regard to shock. He showed that the application of a tourniquet to a shattered limb prevented the occurrence of shock by blocking off the source of the disintegration products, whereas the removal of the tourniquet by re-establishing a communication with the systemic circulation was followed by toxic symptoms. These observations are comparable to ours—toxaemia from the placenta can only arise and be maintained if and so long as part of the placental circulation persists.

Placenta Praevia and Toxaemia.

It sometimes happens that, in placenta praevia, the detachment of the placenta commences some time before the delivery of the uterine contents. If our thesis be correct such cases should be associated with a toxaemia. We therefore decided to conduct an investigation along these lines.

Albuminuria is the earliest definite sign of a toxaemia that we possess, and in this investigation, as in the similar investigation of cases of accidental haemorrhage, the presence of albumin in the urine was taken as the test. This sign is sufficient, but it is well known that a trace of albumin may be present without any other evidence whatever of a toxic process.

Toxaemia has, so far as we know, never been recognized as bearing any relation to placenta praevia, though a number of cases have been recorded in which low implantation of the placenta was combined with albuminuria. The concurrence has been, however, considered as a chance phenomenon. Recently Jardine and Kennedy reported a series of eleven cases of toxaemia so great as to lead to complete suppression of urine, and in two of these (that is, one in five and a half) there was placenta praevia. These conditions are each so rare that unless there is a possible mutual dependence they should occur together only once in several hundred thousand cases.

For this investigation, as for the similar investigation of the cases of accidental haemorrhage, a catheter specimen of urine was obtained as soon as possible after the admission of the patient to hospital, and also at subsequent intervals thereafter. In all the cases bleeding had commenced before their admission.

Our series consists of 7 cases of placenta praevia. Of these 2 had no albuminuria throughout. In 5 cases albuminuria was found. In 2 it increased from a trace at one examination to a heavy deposit at subsequent examinations. In 1 the albuminuria was absent at the first examinations and only developed later. In 3 of the patients the albuminuria was associated with other evidences of toxaemia, oedema of the face, headache, etc., whilst in one of these cases the toxic symptoms were so great that her condition caused considerable anxiety.

This record is striking, and it is, we believe, a powerful confirmation of the argument we are attempting to prove. The series is, however, too small to warrant any far-reaching conclusions, and we wish to avoid any such temptation. We would rather say that we welcome the opportunity of presenting this evidence, especially because it is of a nature that can be put to a ready test in any obstetric clinic. We shall be glad to hear the results of any others who make similar investigations.

The facts, however, raise a suspicion that in the past the toxaemia which apparently is liable to occur in placenta praevia has been overlooked and has been attributed to the collapse and the anaemia of haemorrhage. We may say that, as a control, we examined two cases of severe *post-partum* haemorrhage at intervals and in each case the urine gave negative findings. The changes in the detached praevia portion of the placenta are exactly those which we have described in the detached placenta of accidental haemorrhage. Where time has been allowed for their development the macroscopic and microscopic features of early infarction are found.

Other Causes of Placental Degeneration and Toxaemia.

In the preceding pages it has been shown that mechanical factors may cause a detachment of the placenta from the uterine wall, and, as in placenta praevia and in some cases of accidental haemorrhage, such a mechanical detachment is the cause of the degeneration that ends in toxaemia.

It often happens, however, that in cases of ordinary infarction of the placenta the exact cause of the impairment of the maternal blood supply is difficult or impossible to discover by an anatomical examination. In some such instances there is a thrombosis in the decidual vessels, and we believe that this factor probably operates in a number of cases. But it is impossible of proof, for one cannot tell from the microscopic appearances whether the thrombosis has preceded or followed the necrosis.

So, in many cases of eclampsia and albuminuria in which definite placental disease is present, the exact origin of the blockage of the maternal vessels may not be evident. We have shown, we believe conclusively, that such a blockage can alone account for the placental changes. How, then, are we to explain it in the absence of such simple factors as are present always in placenta praevia and often in accidental haemorrhage? Do mechanical influences operate in these cases as well?

In this connexion we would again direct attention to one of our cases in which the retroplacental bleeding was associated with a haemorrhage into the uterine wall, the tube, and the broad ligament in a way which we could only explain by invoking a sudden strangulation of the right ovarian vein. In the other case of "diffuse utero-placental apoplexy" the appearances again suggested a mechanical strangulation of the veins, but here of both ovarian and perhaps of the uterine veins as well. The conditions were similar but more extensive.

We have referred to the remarkable and suggestive similarity between uteri showing these evidences of strangulation and an ovarian tumour or a pedunculated fibromyomatous tumour with a twisted pedicle. The conditions are so alike that it is almost impossible to escape the conviction that similar causes are operating.

If there are intra-abdominal influences, perhaps of the form of heightened tension, which can in their extreme form culminate in such a dramatic vascular change, it is almost certain that these same pressure factors act at other times in a less marked degree. It is known that, especially in primiparae, there are evidences of increased intra-abdominal tension—for example, swelling of the feet and legs and distension of the right ureter. Is it possible that similar agencies tend to cause venous stasis? In their extreme form this would result in complete strangulation, whilst in its more mild degree it would result in thrombosis of the veins of the retro-placental area or of the uterine wall.

Localized degeneration in the placenta must be due to blockage of the corresponding vessels. Of this we can be certain, but the ultimate explanation must remain of a theoretical nature until we have a more intimate knowledge of the vascular conditions that obtain in the abdomen and pelvis during pregnancy. Paramore maintains that he has actually demonstrated the existence of a heightened intra-abdominal pressure during pregnancy. We have not had an opportunity of carrying out investigations along these lines, but we have a strong belief that it is by such a research that we shall eventually explain the local necrosis of the placenta which underlies some, if not all, of the toxæmias of the end period of pregnancy.

Sequence of Pathological Changes in Eclampsia : Post-partum Eclampsia.

In eclampsia there are widespread evidences of a toxic process throughout the body of the mother, the most prominent of which are the damage to the kidney and liver and nervous system, and the oedema of the subcutaneous tissues. Whether these diffuse changes occur simultaneously in gradually increasing intensity, or whether they follow a definite sequence in their development, we have so far no means of knowing.

In the majority of cases, where the complex of changes culminates in an eclamptic seizure, the clinical picture is completed before or during labour. In other instances, however, the end stages are only enacted after birth, and the convulsions, coma, etc., develop some hours after the escape of the uterine contents.

Post-partum eclampsia constitutes a difficulty that must be candidly faced by the research worker, and it has long been apparent to us that an understanding of this variant of the disease would probably throw new light on the ultimate nature and origins of the toxæmia. Anomalies

are often of greater value than the commonplace features in directing attention to the underlying facts of a disease.

In a preceding communication we tentatively suggested that a piece of dying placenta retained in the uterus might account for the puerperal seizures. This idea we no longer hold, and we are not in a position to offer any other explanation that we can support with proof. We would direct attention, however, to some interesting analogies which may throw some light on the cause of delay in the manifestation of the symptoms in a *post-partum* seizure.

There are not a few toxæmias in which a definite interval is known to exist between the introduction of the poison and the development of the symptoms. In chloroform poisoning the phenomena of toxæmia may not develop for a day or two. But a more interesting analogy is phosphorus poisoning. Here the introduction of a toxic dose may lead to immediate signs of irritation. These pass off, and not till forty-eight hours later do the major evidences of toxæmia develop amongst which convulsions may be present. The analogy between the effects of these chemical poisons and eclampsia is brought home in a striking manner by a study of the tissue changes. In both of the chemical poisons massive damage to the liver occurs, and, in delayed chloroform poisoning, the liver changes may closely simulate those present in eclampsia.

It is impossible to avoid the inference that the immediate cause of the symptoms in such cases is the flooding of the system with the breaking-down products of the liver cells (and perhaps of other organs as well), which were killed at the time of the introduction of the poison, and which in their turn, after a varying but considerable period, generate a new and different poison.

We hold that a conception of this sort is reasonable, and it suggests that eclampsia, as we know it, is possibly not the manifestation of the immediate results of the placental poison, but it is dependent on the flooding of the mother's system with the fission products of the cells of the liver (and perhaps of other organs). It is, as it were, a secondary toxæmia that requires some hours or even days for its culmination. If this explanation be correct, it accounts for the occasional delay of the end stages of the toxæmia till the *post partum* period.

The analogy of the toxic effects of damaged muscle, which we have referred to on a preceding page, is even more suggestive than that drawn from a study of the chemical poisons. The actual products eliminated from the dying tissues of the leg probably resemble those produced in the placenta. As the researches of Delbet and others show, the lethal result in the former case may be delayed for some time, and the animal eventually succumbs to the effects of the disintegration of the liver and suprarenal glands.

Treatment of Eclampsia and Albuminuria.

There are some suggestions with regard to the treatment of the toxæmias of pregnancy which emerge from this research.

1. Separation of the placenta and retroplacental thrombosis are in some cases, and perhaps in the majority of cases, the factors underlying placental degeneration. Mechanical influences, strain, undue exertion, etc., undoubtedly predispose to these occurrences. Rest should therefore form a cardinal part of the treatment of all such cases. In this way an albuminuria may subside because increasing degeneration of the placenta is avoided.

2. Immediate emptying of the uterus is, theoretically, the ideal line of treatment in severe albuminuria and in eclampsia. It is the ideal method, no matter what theory we adopt regarding their origin, for all are agreed that pregnancy is the ultimate cause. In view of the above theoretical considerations, however, it is possible that when major symptoms develop they owe their origin to a poison introduced into the system some considerable time before, and in the interval the placental danger has subsided or disappeared.

Considerations of this kind would account for the very varied results that follow evacuation of the uterus, and they make logical the attitude adopted by most obstetricians, that severe manipulative measures are apt to stir up the toxæmia to dangerous limits, especially by provoking convulsions, which are readily inaugurated by stimulation of the nervous system.

SUMMARY.

1. Eclampsia and pre-eclamptic toxæmia are due to the products of the early degeneration of a piece of placenta whose blood supply has been interfered with.

2. Infarction of the placenta may be due to mechanical detachment of the organ from the uterine wall—for example, in placenta prævia and in some cases of accidental hæmorrhage. In other cases it is due to thrombosis; this is the factor operating in most cases of eclampsia.

3. Where time is allowed for the elaboration of toxic elements from the detached placenta toxæmia develops. In concealed accidental hæmorrhage, therefore, toxæmia is conspicuous. Absorption of placental poisons only occurs if and whilst part of the placenta remains attached to the uterine wall.

4. Toxæmia occasionally accompanies placenta prævia for the same reasons.

5. The toxæmia develops after the hæmorrhage; it is therefore not the cause of the bleeding in accidental hæmorrhage.

6. The major symptoms of eclampsia are probably due to the flooding of the mother's system with the breaking-down products of liver cells (and perhaps of other tissues), which were killed some hours or days previously by the placental poison. Compare the interval that elapses before the development of symptoms in phosphorus poisoning, etc. A consideration of this sort accounts for the occasional occurrence of *post-partum* seizures.

7. Recent investigations on shock (Quénu, Delbet, etc.) support by analogy this conception of eclampsia. These observers have shown that the early disintegration products of muscle are toxic. The injection of these substances into an animal may kill at once. On the other hand, the lethal effect may be delayed for some time, in which case it is due to degeneration of the liver and suprarenal glands. The changes induced in the liver in such a toxæmia resemble those found in the liver in eclampsia.

This investigation was carried out at the instance of the Medical Research Council. It was conducted at the Royal College of Physicians' Laboratory, Edinburgh.

CARDIAC PERISTALSIS AND MITRAL STENOSIS.

BY

D. W. SAMWAYS, M.A., M.D., D.Sc., M.R.C.P.,

MENTONE, FRANCE.

IN an article entitled "Dilatation of the Heart," published in the *BRITISH MEDICAL JOURNAL* of February 5th, 1921, I showed that the pressure which the cardiac walls can, theoretically, exert on their contents varies inversely as the cube of the diameter of the enclosed chamber. Thus, when a chamber has by contracting reduced its diameter by one-half, its walls could, because of their physical advantages, exert eight times as great a pressure on the enclosed residual contents, and when the diameter has fallen to one-third they could exert twenty-seven times the pressure that was possible at first, the force of contraction being the same throughout.

Not that I imagine that the cardiac walls can fully effect this, as they are not perfect spheres, and they have deficient muscular areas at their valve orifices. They must, however, be physically capable of more or less following the physical laws which govern contracting hollow spheres, and of exerting enormously greater pressures on their residual than their full contents, or, expressed otherwise, of expelling their residual contents with much less effort than their first expelled contents.

The principle to which I am calling attention can be readily appreciated by the purchase of a big rubber air-balloon with thick walls, as sold to children, and of a similar small rubber balloon with thin walls. If these are mounted on a three-way glass tube and air blown in by the free orifice, only the big balloon will dilate; the small thin balloon will resist the air pressure which dilates the large thick one. If, now, the inflated big balloon be clamped off and the small one separately inflated, and both afterwards connected together, the

small thin balloon will blow its contents into the large thick-walled one and inflate it further.

I maintain that there are conditions in the working of the heart in which the thin-walled auricle can similarly force its contents into the thick-walled ventricle when the ventricle is contracting against it, and that the appreciation of this fact is essential to understanding much that is observable in cardiology.

It is universally admitted that the auricle begins its contraction before the ventricle. The auricle, therefore, is becoming a small chamber while the ventricle is becoming a large one, through receiving the auricular contents. Towards the end of its contraction the auricle has but a few units of area of blood to contract on, while the ventricle, being full at that time, has many. The auricle also by contraction has thickened, while the full ventricle is at its thinnest. Should the contractions overlap, and the ventricle begin its contraction before the auricle has finished, the supposition of so many writers that the ventricle must in that case overcome the auricle is not evident. In the Bramah press it is not the big piston which overcomes the little one, but the reverse; and the full ventricle is at a greater relative disadvantage than the big Bramah piston, having a minimum of contracting efficiency at the moment when the area of resistance is at its maximum.

Now it is commonly supposed that the contraction of the auricle is over before that of the ventricle begins. This view does not accord with that of many of the most noted earlier observers who specially investigated the subject. Thus Dr. Barclay wrote: "The fibres forming the auricle being intimately associated with those which surround the ventricle, the two cavities do not contract and dilate alternately, but the contraction of the one overlaps to some extent that of the other." He added, however: "When the mitral valve is much altered, the more powerful contraction of the ventricle must overcome that of the auricle if there exists anything like an opposition between them."

Professor Potain, the greatest French authority during the last half-century, maintained that, normally, the closure of the auricular-ventricular valves corresponded in time with the opening of the aortic valves, and that the contraction of the auricle lasted till that closure. Had he been able to conceive that the auricle could oppose the ventricle, if their contractions overlapped, he would not have been forced to place, as he was, the beginning of the ventricular contraction at the moment, or just before, the aortic valves opened.

Professor Potain heard the murmur of mitral stenosis (so-called "pre-systolic") during the apex beat, and, believing it to be due to the auricle, maintained that the ventricular contraction must begin later. Dr. Dickinson heard it also during the apex beat, and maintained that it must therefore be ventricular-systolic in origin. The trouble with these observers was that they could not imagine that the auricle could drive its blood on in spite of the ventricle if their contractions overlapped, whereas I have shown that the chance of the auricle being physically able to do this is greater than the chance of the ventricle being physically able to oppose it, especially when the auricle is hypertrophied.

In the classic investigations made by Professors Roy and Adami² graphic tracings are given showing the relation in time of the chief cardiac events. Roy and Adami actually placed tambours in the cardiac chambers so that the various pressure changes could be exactly recorded. The auricular contraction, as given by them, was at its maximum when the apex beat was at its maximum, and had not finished, in normal cases, when the aortic valves opened, thus showing a marked overlapping of the auricular and ventricular contractions.

Moreover, in harmony with this, Roy and Adami found that the papillary muscles did not contract to support the auricular-ventricular valves till the moment when the aortic valves opened. This strongly suggests that some other force was supporting these valves during the first part of the ventricular contraction. That force, fairly obviously, must have been the contracting auricle itself, which I maintain was physically competent to do it.¹

An overlapping of the systoles is probable *a priori*, for primitive cardiac contraction is peristaltic, and the essence of a peristaltic contraction is that each segment in sequence takes up the contraction and maintains it during the

expulsive period of its successor. In this way the great veins near the auricle contract and close first, and maintain their contraction during the expulsive period of the systole of the auricle. It would require an infinite force to open a fully-contracted vein, so that regurgitation from the auricle is amply prevented. A sphincter is as good as a valve to protect the veins. In birds the mitral valve itself is only a sphincter.

When the auricle contracts, it likewise appears to maintain its contraction, prolonging it into ventricular-systolic time, thus for a period supporting the auricular-ventricular valves. The ventricle also appears to maintain its contraction, as Roy and Adami's curves show, for an appreciable period after the outflow of blood into the aorta, thus for a time supporting the aortic valves.

In the case of mitral stenosis any overlapping of the contraction of the auricle on to that of the ventricle is obviously likely to be increased. It is difficult for the auricle, even if hypertrophied, fully to expel its contents through the stenosed mitral orifice before the advent of the ventricular contraction; and just as the contraction of a ventricle is normally longer than that of an auricle, because of the greater opposition its contraction experiences, so the resistance opposed to the auricle, when the mitral orifice is stenosed, is likely to prolong its contraction, and make it more ventricular in character.

Keyt of Cincinnati, as quoted by Professor Marey³ maintained that "one of the characteristics of aortic stenosis was the long duration of the ventricular systole." Dr. Hilton Fagge wrote: "If the mitral orifice be stenosed, the contraction of the auricle will be slower than normal, and the beat of the ventricle will thus be delayed." Dr. Galabin and Dr. Mahomed made very similar statements, after examining their graphic curves taken in cases of mitral stenosis. Dr. Sansom⁴ wrote: "It is obvious not only that the auricle (in mitral stenosis) contracts in a manner much more powerful and much more prolonged than under normal conditions, but also that it contributes in very marked degree to the general elevation (apex beat) which is completed by the systole of the ventricle." French writers, such as Dr. Constantin Paul, have advanced much the same opinions.

Observers such as these could not follow to a useful conclusion the evidence of their senses, because they believed that the power of the auricle did not count as compared with that of the ventricle, and that any overlapping of their contractions could have no physical utility.

As a matter of fact there is no obvious reason why, if the auricle has contracted to, say, half its diameter, in a case of mitral stenosis, before the contraction of the ventricle opposes it, the auricle should not continue to send on its residual contents into the full ventricle, the aortic valves opening, or the ventricle expanding to receive them. This is rendered the more possible by the fact that the walls of the ventricle, in well marked mitral stenosis, are thinner than normal, while those of the auricle are hypertrophied. I have seen an auricle with walls hypertrophied almost to the thickness of the ventricle. Dr. B. Foster and Dr. Sansom have reported auricles with walls measuring up to 6 mm. in thickness, exceeding, that is, the thickness of the right ventricle.

The ventricle can never exert its potential power of opposing the inflow of the residual blood from the auricle, because directly its contraction has raised the intra-ventricular blood pressure above that in the aorta its contents escape into the latter, and no further raising of blood pressure on its part is possible. The maximum resistance the auricle could, therefore, ever find opposed to it by the ventricle is determined by the pressure in the aorta, and an auricle towards the end of its contraction, especially if hypertrophied, could, theoretically, being small, exert a sufficient pressure on its residual contents to overcome this. Allen Burns described a case under his observation in which the ventricles became calcified, and the man lived for a long period with the auricles alone doing the whole work of the circulation.

It may be objected that in cases of mitral stenosis the auricle dilates as well as hypertrophies. I believe this to be one of the fictions of medicine. In a paper published in 1898⁵ I gave particulars of an analysis I made of all the *post-mortem* reports of Guy's Hospital during the ten years 1886-95. Out of a total of 4,791 necropsies during that period, there occurred 196 cases of stenosis of the mitral orifice. Of these cases, 23 came from the surgical wards,

and only one among them appeared to have died of asystole due to the stenosis, which was severe. If this case be excluded dilatation of the left auricle was only observed in 3 of the remaining 22 cases, where death occurred from accident or operation before the heart broke down. Dilatation, therefore, is not a feature of the disease during its course. I doubt if 3 in 22 be materially greater than the average for the heart generally at necropsies. The paper referred to established the fact, so far as statistics could establish it, that the characteristic change in the left auricle in mitral stenosis is hypertrophy, and that dilatation is a break-down phenomenon occurring late in the disease.

CONCLUSIONS.

1. There is considerable evidence to show that the contraction of the auricle normally overlaps that of the ventricle, lasting probably till the moment of opening of the aortic valves.
2. That in cases of mitral stenosis this overlapping tends to be still further prolonged, invading therefore the expulsive portion of the ventricular systole.
3. That the ventricle could not prevent the auricle sending its residual blood into it, if their contractions overlapped, because at that time the auricle, being small, would have few units of area of blood to contract on, and a thickened mass of muscle to exert the necessary pressure, whereas the ventricle would be in exactly the reverse position at the time.
4. In cases where the mitral was stenosed the auricle would be further helped by hypertrophy of its walls and thinning of those of the ventricle.
5. That the murmur of mitral stenosis ("presystolic") goes up to and into ventricular-systolic time because the blood flow does likewise.
6. That the murmur is "crescendo" in character because the auricle can exert an ever-increasing pressure on its contents as it contracts. Theoretically the pressure can increase inversely as the cube of the decrease in diameter.
7. That regurgitation through an incompetent mitral orifice is prevented, probably for years, by the contraction of the auricle behind that orifice during the expulsive portion of the ventricular systole.
8. That the presystolic murmur is replaced by a systolic murmur when the auricle cannot decrease its size in time to become a sufficiently small chamber to defeat the oncoming of the intraventricular resistance, but on the contrary is defeated by it. This will allow regurgitation, the auricle will speedily dilate, fibrillate, and compensation will break down.
9. Temporary recovery by rest or bleeding will probably mean that the auricle becomes again, for a short time, master of the situation.

REFERENCES.

- ¹ *Lancet*, March 16th, 1872. ² *Practitioner*, vol. 41. ³ *Circulation du sang*, p. 667. ⁴ *Albutt's System of Medicine*. ⁵ *BRITISH MEDICAL JOURNAL*, February 5th, 1898.

BILHARZIA DISEASE IN EGYPT.

BY

J. B. CHRISTOPHERSON, C.B.E., M.D.,
F.R.C.P., F.R.C.S.

TROPICAL DISTRICT CLINIC, MINISTRY OF PENSIONS; CHIEF DIRECTOR OF THE CIVIL HOSPITALS OF BEARTOWN AND OULDERMAN.

THE outstanding facts in Drs. Lasbrey and Coleman's article on 1,000 cases of bilharzia treated by antimony tartrate, in the issue of the *BRITISH MEDICAL JOURNAL* of February 26th, are, as it seems to me—

1. The prevalence of the disease in and around Cairo.
2. The applicability of the treatment of bilharzia—both complicated and uncomplicated cases—by intravenous injections of antimony on a large scale in Egypt; and, most striking of all.
3. That the prestige of the British doctors with the fellahs of Egypt, at the present period of national unrest, is proof against the prejudice aroused by religious and political mischief makers.

The cases were all voluntary, and, since the completion of this series of 1,000 cases in August, 1920, another 1,000 have been done in five months. The C.M.S. Hospital, Old

Cairo, is by no means the only hospital in Cairo where large numbers of bilharzia cases are coming for treatment; the Kasr-el-Aini Hospital, if my information is correct, has treated about 1,600 cases of bilharzia by the intravenous method during twelve months, and other hospitals and practitioners in Cairo are similarly treating numbers of patients, though naturally on a smaller scale; also the Government hospitals in the provinces, some of which have a still larger number of cases to their credit even than the Kasr-el-Aini, and other hospitals, are carrying out the treatment. The great number treated is striking, but bilharziasis is so deeply rooted and prevalent in Egypt that, in my judgement, hospital treatment alone, even on this large scale, will take a long time to make an impression on it as a national disease; the sources of reinfection, too, are many. It should be remembered, however, that each case, when cured by antimony tartrate, ceases to convey infection, owing to the fact that the ova deposited in the bladder and rectum are also killed by the remedy—in other words, the patient ceases to be a "carrier."

The report of the first 1,000 cases treated at the C.M.S. Hospital, and the lucid description of the simple technique employed, is testimony that antimony tartrate is efficient for dealing with bilharziasis on a large scale, and capable of being applied in Egypt. Antimony tartrate is cheap, the cost of the amount sufficient for the course of treatment for one case is 1s. It is stable, it is easily procurable, it is soluble, and solutions containing it can be sterilized by boiling as often as necessary before use. These facts are all advantageous for working in a sub-tropical country and in out-stations. Antimony tartrate, when given by the veins, is, in all probability, not so toxic to the patient or injurious to the tissues as is generally supposed.

The method of administration is simple of application, but, as Drs. Lasbrey and Coleman's article shows, it needs practice, and, if carried out on a large scale, the arrangements need considerable organization. There are many details of method to attend to. Finally, it is not a remedy to be placed in the hands of the careless and the inexperienced.

Bilharziasis is so prevalent in Egypt, and the sources of reinfection after treatment are so numerous, that this direct method is alone not sufficient for dealing with the disease nationally, and in this connexion there is a trait in the character of the Egyptian which militates against the success of simple hospital treatment. The course of treatment at present lasts at shortest seventeen days, and usually three weeks; it may take a month. The Egyptian fellahcen reserves to himself the right to determine when the cure is completed. When he is free from pain, when his urine looks normal, when the act of micturition is normal, then, according to his standard, he is cured. His decision is made often too early, as the doctor knows from microscopic investigation. However, the patient thinks he is cured, and he goes away and cannot be traced. This happens possibly in one-third of the cases treated in Egypt, and it was found advisable by Drs. Lasbrey and Coleman to let the patients bring their mats and sleeping paraphernalia and to accommodate them in the hospital grounds during the course. The only drawback I know to out-patient treatment is this liability of patients to cease attending before the course is completed; it is a serious one, however, and as patients with bilharzia are very numerous in Egypt, and as it is impossible to treat a whole nation in the wards of a hospital, treatment modified according to circumstances is necessary and advisable. Treat the patients as out-patients, but take the treatment to the villages of the people, would seem to be the solution.

Many of the cases—they are the worst from the point of view of spreading infection—are too mild for the sufferer to bother to see a doctor; others are too bad, and, believing there is no cure, die in their villages. Practically the majority of sufferers will not seek hospital relief of their own accord. Therefore the organization of small mobile out-patient hospitals is needed with mobile laboratory attached, and a staff chiefly or in some instances entirely composed of Egyptians; it would take up a position in or near a village and would, from the Omdar or Sheikh, get a list of sufferers; such a mobile hospital would particularly work through the schools—the young are the chief sufferers.

I am not so optimistic as to believe that a clean sweep of the bilharzia cases in any village would be made in the

first instance, or for some years, but if care were taken to send only experienced and careful workers (Egyptian for preference) whose judgement as regards the dose and whose skill in the technique of the operation, and whose care in the preparation of the paraphernalia can be relied on, confidence would be secured and sufferers would come forward voluntarily, and, after a short time, there would be less trouble in applying the injections than there is in doing vaccinations for small-pox. In a short time a travelling hospital, instead of sitting down near a village and treating only a percentage of the sufferers, would be welcomed and would remain until all the bilharzia cases in the vicinity suitable for treatment were dealt with. It would then move on to fresh ground. Cases which were unsuitable for out-patient treatment would be sent to a hospital—no doubt in the car attached to the mobile unit.

But the organization of mobile hospitals, together with the present general hospital treatment, extensive though it is, is in itself not sufficient to deal with so prevalent a disease as bilharzia in Egypt on a national basis.

Leiper's discovery of the life-history of the bilharzia schistosome—its extra-corporeal stages of development in the mollusc (*Bullinus* and *Planorbis* in Egypt)—placed Egypt in possession of information the practical value of which lies in the fact that it can be applied on an economic basis for the purpose of extermination of the mollusc, and so stamping out bilharzia. Without these molluscs bilharzia disease could not exist in Egypt. It is probably impossible to eliminate the molluscs completely, but an advance can be made in two directions in dealing with them. In the first place an attempt may be made to exterminate them, and, in the second, measures may be taken to try and prevent those which cannot be exterminated from becoming infected with bilharzia.

But bilharzia will not be eliminated as a national disease from Egypt by the application of the antimony tartrate remedy, although supplemented by the hygienic measures suggested by Leiper¹ for dealing with the all-important mollusc—sound and thorough though they undoubtedly are. In order to achieve the object in view the co-operation of the natives must also be sought. That they will co-operate in spite of religious prejudices, ignorance and primitive notions, is evidenced by the fact that so many as 1,000 cases of bilharzia in one year at one voluntary hospital and 1,000 at another voluntary hospital in the same town sought the treatment.

The Egyptian mind is receptive; education by lessons at the primary school, by instruction at hospitals, by instruction of the general public by propaganda work, lectures, magic lanterns, advertisement posters, cinematographs—in fact education by publicity is what it needs.

It must not be thought that nothing is now being done by the medical authorities in Egypt. The Egyptian Sanitary Department is fully alive to the importance of this great question of bilharziasis. It has arranged for treatment to be carried out in the Government hospitals, and is moving in the direction of education of the fellahcen by means of lantern slides and diagrams and lectures. Native unrest possibly has prevented more being done so far.

CONCLUSION.

In order to eliminate the scourge from Egypt, it might be dealt with systematically on a much larger scale, and steps might now be taken to get rid of it by supplementing the present stationary hospital arrangements—

- (1) By working through the country with mobile hospitals with laboratory attached;
- (2) By adopting measures for the destruction of molluscs, and for preventing those which cannot be destroyed becoming infected;
- (3) By education of the fellahcen in the causes, prevention, and cure of the disease, and acquainting them with the life-history of the parasite by means of lantern slides, pictures, posters, lectures, cinematographs. The mobile hospitals would with advantage have a cinematograph attached, and the three great helminthic diseases of Egypt—*Hymenolepis nana*, ankylostomiasis, and bilharziasis—"featured." There is no reason why the cinematograph should not be used in this important medical educational work, with very great advantage to Egypt.

REFERENCE.

- ¹ *Journal of the Royal Army Medical Corps*, 1915, vol. ii.

FIVE HUNDRED CASES OF MALARIA IN PENSIONERS.

BY
JENNER HOSKIN, M.R.C.P.,

HONORARY PHYSICIAN, QUEEN MARY'S HOSPITAL FOR THE EAST IND.

DURING the latter half of 1919 a very great number of demobilized and discharged soldiers appeared before the various pensions' boards throughout the United Kingdom, claiming for disabilities incurred during service in the late war.

The following table gives the correct figures for the months of October, November and December, 1919:

	Oct., 1919.	Nov., 1919.	Dec., 1919.	Total for 3 months.	Per-centage.
Total malarial cases ...	5,626	6,702	6,972	19,300	7.7
Total number of cases ...	77,308	86,461	84,518	248,217	100
Total wounds and injuries cases ...	2,4864	29,326	29,418	84,108	33.8
Total diseases cases ...	52,444	55,635	55,100	164,179	66.2

These numbers comprise all those men who have appeared before the pensions' boards during these three months. Of the total, 33.8 per cent. were claiming a pension for wounds and injuries, and the remaining 66.2 per cent. for various diseases. The malarial cases examined during this period were 19,300, or 7.7 per cent. of the total number of cases seen—that is, 1 in every 13 cases. Comparing the malarial cases with other diseases, the percentage is 11.6, or 1 in every 9 cases. Since obtaining these figures the proportion of malarial cases seen has increased.

From the United Kingdom 5,704,416 men were sent overseas, and of these roughly 400,000, or one-fourteenth, served in malarial countries.

Thus it can be realized that malaria has played a big part, not only amongst the casualty diseases during the late war, but is still continuing to cause a large amount of sickness and expense, both through loss of man power and pensioning at the present time. This shows that the incidence of malaria in those serving in countries where the disease is endemic is very high, and that the prognosis as regards complete recovery is bad.

The 500 cases to be described were examined consecutively at the Ministry of Pensions, and comprise 356 men who contracted malaria on the Salonica front, 62 from Egypt and Palestine, 45 from East Africa and 37 from other theatres of war, including a few recurrences of fever contracted during service in India prior to 1914.

I have endeavoured in these cases to compare the three main malarial theatres of war—that is, Salonica, Egypt and Palestine, and East Africa—and to show in what respects their immediate and later effects resemble and differ from each other.

1. *Discharged Medically Unfit.*—The following table gives the totals and the percentages:

	Total.	Percentage.
Salonica	45	12.6
East Africa	13	28.9
Egypt and Palestine	5	8.1
Miscellaneous	6	16.2
Total for all theatres	69	16.4

Thus over 16 per cent. of these collected cases had been discharged permanently unfit. This is a considerable proportion since it does not take into account the large number who have died from the disease. The other feature about the above table is the high percentage, 28.9, of the cases contracted in East Africa.

2. *Length of Service.*—There was also quite a marked difference in the average time spent in the malarial country before the soldier was transferred to a non-malarial theatre of war. The following table shows that the average time spent in East Africa was considerably less than that spent in Salonica and in Egypt and Palestine.

It is difficult to account for the difference, but it seems that the length of the lines of communication had a great deal to do with it. This was in a great measure responsible for the difficulties in bringing up supplies, in establishing hospitals with adequate accommodation and necessary comforts, and in setting up ordnance depôts where the men could be provided with fresh boots and clothing to replace those worn out or lost on the campaign.

Theatre of War.	Average Times in Months.
Salonica	24.23
East Africa	14.15
Egypt and Palestine	24.37

In all these three theatres of war, malignant tertian fever was common. Unfortunately, I was only able to get a record of the type of infection in a very limited number of cases. All these cases were sent for blood examination at the time of being boarded, but were in every case negative, save in two in which benign tertian trophozoites were found.

3. *Seasonal Prevalence.*—An examination of the seasonal prevalence on the three malarial fronts also showed certain differences.

In Salonica the malarial incidence rose in June and continued high through the summer months, reaching its maximum in September. October showed a slight decline, and the minimum was reached in January. In Palestine and Egypt the number of malarial cases rose in July, continued through the summer months, reached its maximum in October and November, and then dropped rapidly, reaching its minimum in March. In East Africa the seasonal prevalence was not marked, and showed only slight increases in January, March, April, and June.

The following table gives the numbers and percentages found:

	Salonica.		Palestine and Egypt.		East Africa.	
	No.	Percent.	No.	Percent.	No.	Percent.
May	18	6.1	2	3.7	3	7.7
June	42	14.3	3	5.6	5	12.8
July	33	11.2	7	12.9	3	7.7
August	43	14.6	6	11.1	3	7.7
September	58	19.7	7	12.9	3	7.7
October	36	12.2	12	22.2	3	7.7
November	23	7.7	11	20.4	2	5.1
December	8	2.7	2	3.7	2	5.1
January	2	0.7	1	1.4	4	10.3
February	6	2.0	1	1.4	2	5.1
March	12	4.0	0	0	4	10.3
April	15	4.8	2	3.7	5	12.8

The following suggestions are put forward to account in some measure for the seasonal differences.

1. *Climatic.*—Salonica, Egypt, and Palestine are non-tropical countries, and as such undergo marked variations in external temperature, depending on the time of year. In Salonica especially the winters are severe, and in Palestine and even Egypt the differences between the winter and summer temperatures are quite marked. East Africa, on the other hand, is tropical, the equator passing through British East Africa, and the theatre of war being situated directly south of this. For this reason there is very little difference in the winter and summer temperatures, and any coolness is dependent on the rains. These occur in the various parts of the country at different times of year. Thus, in the interior plains, the rains commence about October. In the highland plateau they are later, not appearing till December and lasting till the middle of April. On the coast the rains commence about June. Now, just as a certain temperature is essential for the breeding of mosquitos, so also is an adequate amount of water necessary for the depositing of the eggs. During the dry months the heat of the sun tends to dry up all collections of water, so preventing the eggs hatching. Also, the heavy rains are apt to wash away and destroy deposits of eggs, so that the mosquito has to wait till the end of the rainy season, when there is a plentiful supply of suitable water, before its eggs can be hatched out to the

best advantage. For this reason the seasonal prevalence of malaria alters for the various parts of the country, depending on the time of the rains.

2. *Conditional.*—By this is meant the alterations of service conditions in the increasing or mitigating the contraction of the disease. This especially applied to Palestine, where the rapid advance into the highly malarious country of the Jordan Valley in the summer of 1918, accounted for a very great number of the total malarial cases. Unlike Salonica, Egypt and Palestine were not wholly malarious; and, in Palestine, where the majority of cases occurred, the incidence seemed to depend on the movements of the troops from a camp where antimosquito measures had been effectively taken into a fresh unprotected and more highly malarious district.

Salonica itself is a highly malarious country, notably the Struma Valley, where many miles of marsh land render satisfactory antimalarial measures quite impossible owing to the enormity of the task. Another factor was that in this theatre of war the campaign was less progressive, so that the incidence depended for the most part on the climatic conditions. This is indicated in the following table, showing the number of cases and the percentages contracted on the three fronts during 1915 to 1919 inclusive. It will be noticed that the years 1916 and 1917 show the highest malarial incidence, which declined markedly in 1918. During the autumn of 1915 a few troops only were disembarked at Salonica, and no serious operations were attempted that year. The year 1916 shows increased activity. Large numbers of reinforcements arrived, and an advance was made into the Struma Valley. In this highly malarious part, the incidence during the summer and autumn months was very high. In 1917, more reinforcements arrived, and the advance, which had been held up for more than a year, recommenced. Monastir was recaptured, and fresh malarial country opened up. This year showed the maximum incidence. The incidence declined in 1918, when sanitary measures began to prevail, and more suitable country was occupied by the troops.

In East Africa the real offensive commenced with the arrival of General Smuts in the spring of 1916, and by the autumn of that same year the whole of German East Africa north of the central railway running from Dar-es-Salaam to Ujiji was freed from enemy forces. This part, though malarious, was not so highly infected as further south, where the next stage of the campaign was fought. This fresh country became the seat of operations in 1917, and the climatic conditions here, especially during the rains, could easily account for the marked increase of malarial cases. In fact, the climatic conditions were considered so deleterious that practically all European troops were replaced by Indian and East African native troops. This is probably the reason of the decrease in number for 1918, as only men from the British Isles are noted in these cases.

Palestine shows the most interesting figures. In 1916 the troops were advancing towards El Arish, in 1917 they were hung up before Gaza, and only in 1918 was made the big advance ending with the capture of Jerusalem and Damascus. It is generally observed that even in highly malarious countries stationary camps in time become fairly healthy, as modern sanitary methods have been found most efficient in combating the anopheles; stagnant water is either got rid of or treated, proper mosquito-proof beds and living rooms are constructed for the troops, and also the protective measures can be more easily enforced. The great advance took place early in 1918, and, once started, continued very rapidly. The troops had no time to take adequate protective measures against infection, suffering the more on this account. In addition, the country through which they were passing was highly malarious. Major Manson-Bahr, in describing the malarial incidence from *Laverania malariae* and *Plasmodium vivax*, shows that in the eastern sector from the Jordan Valley to Jerusalem, during the summer of 1918, the benign tertian epidemic commenced the beginning of June, and reached its maximum of 340 cases a week on July 13th. The malignant tertian epidemic commenced later and was very severe, reaching its maximum of 1,800 cases a week on October 12th. In the western sector from Jaffa to Ludd the benign tertian epidemic was the more severe, and reached its maximum of 850 cases a week on August 3rd.

It was followed by a less severe epidemic of malignant tertian, reaching its maximum of 600 cases a week on the same date as in the eastern sector.

	1915.		1916.		1917.		1918.		1919.	
	No.	%	No.	%	No.	%	No.	%	No.	%
Salonica	5	1.4	117	32.2	173	48.0	59	16.6	3	1.0
East Africa... ..	2	4.8	10	23.8	22	52.4	7	16.6	1	2.4
Palestine and Egypt	3	4.8	7	11.3	13	20.9	38	61.4	1	1.6

I have to thank Sir Lisle Webb, Chief Commissioner to the Ministry of Pensions, for his kindness in allowing me to publish these cases, and for some of the statistics supplied to me.

A NOTE ON THE SURGICAL USES OF THE FASCIA LATA.

BY
CYRIL H. CUFF, M.B., B.S. DURH., M.R.C.S.,
NEWCASTLE-ON-TYNE.

THE extraordinary variety of injuries to all parts of the body which occurred during the war afforded to surgeons concerned in their treatment vast opportunities for exercising their ingenuity and invention. The application of the fascia lata to the repair of many of these lesions certainly received a great stimulus, and the results were on the whole eminently satisfactory. As one who, during the last eighteen months, has utilized fascia lata fairly extensively in different conditions, I venture to indicate some of its more obvious applications.

I. In the repair of, or as a substitute for, tendons and ligaments:

- Injuries in which there is loss of tendon substance, recent or old standing.
- In lieu of dividing and transplanting a healthy tendon, in order to reinforce a paralysed one, connecting these two by a fascial intermediary tendon.
- As a substitute for intrinsic or extrinsic articular ligaments—for example, the crucial (Hey Groves) and the internal lateral ligaments of the knee.
- As an auxiliary ligament—for example, in lieu of tendon fixation for a "dropped" foot—a Y-shaped fascial ligament may be employed; or in recurrent dislocation of the shoulder a fascial "sling" passed through the quadrilateral space may be used, or it may be passed through a hole drilled in the head of the humerus and the acromion process.

II. For clothing an area which has been deprived of its normal covering tissue.

- After the excision of adherent scars.
- In the abdomen, after extensive resections of the colon, to aid in "peritonization."
- In arthroplasties, interposed between the two raw bony surfaces (Murphy).
- As a sheath to protect a nerve suture.
- In gunshot or other injuries of the skull, where there has been extensive loss of substance of bone and dura mater prior to bone grafting.

III. To reinforce defects in the parietes of the chest, the abdomen, and of vessels.

- To cover in a lateral defect in a vessel wall.
- In repair of the urethra, after excision of stricture.
- In closure of faecal fistulae and ventral hernia, where parietes are deficient.
- In reconstruction of an intercostal space in hernia of the lung.

There are doubtless many other purposes to which this valuable tissue can be applied, and the above list only aims at giving some concrete idea of its scope.

Among the many little details that count towards success are the following: first, that the graft should be of

ample proportion and should be treated with the same respect as a bone graft; secondly, when used as a new ligament, the greatest care should be taken to imitate the anatomical attachments of its predecessor; and thirdly, that when used as a ligament, tendon, or to reinforce parietes, there should be no "slack" after suture is completed.

Memoranda:

MEDICAL, SURGICAL, OBSTETRICAL.

INCUBATION PERIOD OF SCARLET FEVER.

In view of the fact that in accordance with "A Code of Rules for the Prevention of Infectious and Contagious Diseases in Schools," issued by the Medical Officers of Schools' Association, the incubation period of scarlet fever is given as "one to eight days, usually three to five days," I think, perhaps, the following instances in which the incubation period appears to have been ten days or more may be of interest. It may, of course, be said that they do not prove anything conclusively, but anyway they are in favour of the incubation period being longer than it is usually supposed to be.

1. Two children (M. and P.) travelled to a seaside convalescent home from London on February 9th with two other children who had recently been under treatment for scarlet fever. M. was taken ill with the disease on February 19th, and P. on February 24th. No other cases in the home on arrival.

2. Two children (T. and B.) travelled to a seaside convalescent home from London on February 2nd with a child who had recently recovered from scarlet fever. T. was taken ill on February 23rd, and B. on March 1st. Possible infection in the home.

3. Two children returned from their home to a private boarding school. The next day notice was received that a sister at home, with whom they had been in contact, had developed scarlet fever. The two children were immediately isolated, and developed scarlet fever, one nine days and the other ten days after returning to school.

4. A child was admitted to a private boarding school, and developed scarlet fever exactly ten days afterwards. So far as could be ascertained, there were no other cases in the school or neighbourhood.

5. In a convalescent home four cases of scarlet fever occurred under the following circumstances: F. C. arrived on January 27th, was taken ill on February 26th; E. D. arrived on February 3rd, was taken ill on February 22nd; F. C., an inmate, developed scarlet fever on February 26th; M. W. arrived on February 6th and was taken ill on March 12th.

6. In a convalescent home two children were taken ill with scarlet fever on July 31st; they arrived at the home, where there had been no other cases, on July 23rd; another child arrived on August 13th and was taken ill on August 22nd.

Broadstairs.

A. M. WATTS, M.D.

MEASLES, INTUSSUSCEPTION, AND APPENDIC-ECTOMY IN A BABY SEVEN MONTHS OLD.

A boy aged 7 months, breast-fed, was admitted into the Dorset County Hospital on November 29th, 1919. He had measles, but up to the previous day he had otherwise seemed well. On the 29th he passed a healthy motion early in the morning, and about 11 a.m. he seemed to be in pain. He vomited his feed at 1 p.m., and passed a green motion. He refused the breast during the remainder of the day, and had spasms of screaming and retching. At 7 p.m. he passed a blood-stained motion with mucus. Shortly afterwards he was admitted to the hospital.

On admission the patient was a well nourished child thickly covered with the rash of measles. A hard mass could readily be felt to the left of the umbilicus. Under an anaesthetic an incision 2 inches long was made over the swelling. A finger could follow the swelling towards the left iliac fossa, and after a little manipulation that portion of the descending colon containing the apex of the intussusception was delivered into the wound, and by gentle pressure below its lowest point the intussusception was reduced with surprising ease. As each portion of the bowel involved was dealt with it was returned into the abdominal cavity until the ileo-caecal valve was reached. The appendix, abnormally long, was for half its distal portion very dark in appearance—almost gangrenous—this apparently being due to its blood supply having been cut off. The appendix was removed. The caecum and ileo-caecal valve felt very thick and oedematous, and the peritoneal coat of the former was roughened. The child stood the operation well; there was no vomiting subsequent to the operation. He took his feeds well; these were restricted at first in amount and frequency. A small greenish stool was passed eight hours after the operation, and faecal matter began to appear in the stools in twelve hours.

The temperature, which was raised on admission, dropped to normal in a few days, and the wound healed by first intention. It was fortunate that the caecum and appendix could be pulled into a wound to the left of the umbilicus.

The combination of measles, appendicectomy, and a successful operation for intussusception of such a long portion of the bowel in a child of 7 months, makes the case perhaps worthy of record. I have seen the boy a short time ago, and he has been in perfect health since his operation.

B. W. GOWRING, M.D., M.R.C.S.,
Honorary Surgeon, Dorset County Hospital.

THE SARCOPTIC MANGE OF THE DOG IN MAN.
The lecture recently given by Professor Hobday before the combined meeting of the Royal Society of Medicine and the Central Veterinary Medical Society on the contagiousness of certain diseases of animals to man, recalls to my mind an instance five years ago when a pug dog, the subject of sarcoptic mange, transmitted the disease to a family of six people.

The little animal was a great pet, and became very badly infected before any treatment was adopted, the extent and nature of the disease not being realized. The dog used to lie against the people's legs in front of the fire, often for half an hour or more at a time, pressing himself against them, and each developed the infection, which was in the form of an extremely irritable rash, not unlike lichen planus in appearance. It lasted for about six or eight weeks, and did not disappear until after the skin disease on the dog had been taken in hand, treated and cured.

I am pleased to see that attention has been drawn in a medical gathering to the subject of the contagiousness of certain animal diseases to man, as I am quite sure that its importance ought to be more fully realized and lectured upon in the curriculum of the student.

W. H. COATES, M.B., M.R.C.S., L.R.C.P.,
M.O.H. Patrington, East Yorks.

Reports of Societies.

PUERPERAL SALPINGO-PERITONITIS.

At a meeting of the Section of Obstetrics and Gynaecology of the Royal Society of Medicine, on March 3rd, with the President, Professor HENRY BRIGGS, in the chair, Dr. ALECK W. BOURNE read a paper on "Acute puerperal salpingo-peritonitis." He justified his modification of the name of a common disease as it emphasized the fact that the condition was entirely different from acute non-puerperal salpingitis in morbid anatomy, physical signs, and treatment. The morbid anatomy was largely determined by the anatomical position of the involuting tube and uterus at the time when the inflammation occurred; suppuration thus tended to be primarily extra-pelvic and abdominal, causing abscesses above the brim of the pelvis. Further points were the early obliteration by adhesions of the pouch of Douglas, secondary ovarian infection, secondary cellulitis of the upper portion of the broad ligament, and the arrest of uterine involution so long as infection was unrelieved. The cause of puerperal salpingitis was, he stated, an organism (streptococcus in three of the tubes examined) which either ascended from the uterus, probably the commonest mode of infection, or which had existed dormant in the tube from pregnancy, as proved by a case of salpingitis following Caesarean hysterectomy where the tubes were absolutely normal, or which provoked an exacerbation of a pre-existing salpingitis during the puerperium. The symptoms were those usually found in acute peritonitis of the lower abdomen, and were not particularly noteworthy. The chief points were that the temperature and pulse tended to be high, more so, for instance, than in acute appendicitis; the lochia was usually unaltered; and retention of urine or painful micturition might denote an extensive secondary cellulitis. The physical signs required careful examination. On examination of the abdomen the initial tenderness was at a point just below and external to the umbilicus; the fundus uteri was at first median and rose about two inches above the

symphysis, and pressure on the fundus soon caused pain; there was pronounced tenderness above the inner part of Poupart's ligament, indicating secondary cellulitis; after an interval there was rigidity and tenderness of the lower abdomen; any hypogastric tumour, apart from the fundus uteri, was due to omentum and coils of adherent intestine; and, later, asymmetry of the fundus uteri was caused by secondary cellulitis. On vaginal examination there was an absence of physical signs except general tenderness, but later a mass could be felt high up in the postero-lateral fornix, due to the ovary surrounded by the adherent coils of intestine. By the rectum, the formation of a tube-peritoneal mass was more usually felt, and at an earlier date, than by the vagina. The treatment was early laparotomy. The chief reasons for early operation were the prevention of extending peritoneal abscesses; the anticipation of the formation of dense adhesion; prevention of infection of the ovary, which occurred early and was difficult to eradicate apart from oophorectomy; prevention of a spreading secondary cellulitis; and to enable the subinvolved uterus to undergo involution and thus prevent a chronic uterine hypertrophy.

Dr. GEOFFREY EVANS read a paper on "A study of the condition of the arteries in a uterus removed twenty-four days after delivery." He referred to the work of A. Helme, who showed in 1887 that fatty degeneration did not occur in the normal involution of the rabbit's uterus; but more recently James Goodall had established the opinion that fatty degeneration did occur in normal uterine involution. Dr. Evans's paper was founded on a specimen prepared by Gaskell's method and cut frozen, so that the cells retained more nearly their normal form, and any fat present was not dissolved out of the tissues. He found that the histological picture was that of normal arterial involution, as it occurred elsewhere in the body under physiological conditions; and there was no fatty degeneration of the muscle fibres in the medial coats of the arteries. His submission, therefore, was that the question of the presence or absence of fatty degeneration in the media of the vessels in the puerperal uterus was not as yet definitely settled.

Dr. RUSSELL ANDREWS, Dr. HERBERT SPENCER, Dr. HERBERT WILLIAMSON, and Dr. A. C. PALMER showed a series of pathological specimens.

TREATMENT OF UTERINE PROLAPSE.

At a meeting of the Edinburgh Obstetrical Society, held on March 9th, with Dr. WILLIAM FORDYCE, the President, in the chair, Dr. SAMUEL CAMERON (Glasgow) read a paper on the surgical treatment of uterine prolapse. He referred to the fact that the plastic operation had developed within the past twenty years. Nowadays he never used methods of abdominal fixation, and believed that adequate results could be obtained by plastic means. He employed three operations, the choice being mainly influenced by the age and by the physical condition of the patient, and also by the number of living children which she had. When the patient had several healthy children, and was about the menopause, the interposition operation was recommended; but if she was a young woman, Fothergill's modification of colpo-perineorrhaphy should be the operation of election. In frail elderly women he practised an operation which he had devised. Within the past five years he had operated on 292 cases of prolapse. The interposition operation he had performed 136 times and, so far as records showed, these cases had remained cured. In doing this operation on a patient before the menopause he always carried out sterilization. He recorded one case in whom this precaution was not taken, and who subsequently became pregnant. The gestation continued to full time, when Caesarean section was performed, with the birth of a healthy child weighing 9½ lb. The uterus had expanded entirely at the expense of the posterior wall. It was interesting to note that the bladder had been pushed to one side, rendering access to the uterus easy.

The operation which he performed in frail elderly women consisted in amputation of the cervix by a circular method after a flap of vaginal mucous membrane had been reflected up for a short distance. An incision was then made in the perineum as for ordinary perineorrhaphy, and the incision was deepened until the vaginal wall was liberated to a fair extent. The cervical stump was pulled downwards and moored by sutures in the raw tissues of the vaginal wall and perineum. Thereafter the perineum was closed up in the ordinary way.

He had performed this operation twenty-four times, and only one had failed, owing to non-union of the cervix with the vaginal flap and perineal tissue. The first case was operated on over four years ago. His fear when he first performed this operation was that the patients might develop pyometra, but so far this had not happened.

The PRESIDENT had never performed the interposition operation, which did not, to him, seem to possess any advantage. He believed that an extensive plastic operation was all that was required.

Dr. HAIG FERGUSON found that the extensive plastic operation as ordinarily practised gave excellent results, even with the worst cases of prolapse. He thought that Dr. Cameron's operation was associated with a distinct risk of pyometra, for one knew that even after ordinary cervical repair or amputation this result might follow.

Haemorrhage with Eclampsia.

Dr. FORDYCE and Dr. R. W. JOHNSTONE read a paper on a case of concealed accidental haemorrhage with eclampsia. The case was a primipara who had been well up till the eighth month of pregnancy, when without warning she was seized with pain in the abdomen and breathlessness. Soon afterwards vaginal haemorrhage appeared. On admission to hospital she was collapsed, there was considerable oedema of the trunk and lower limbs, and the urine was scanty and contained a large quantity of albumin. As the pulse rate increased, and toxic symptoms began to manifest themselves in a dimness of vision, sickness and a slowly increasing tendency to coma, Caesarean section was determined upon. At the operation the upper part of the uterus was deeply congested and haemorrhagic. It was most marked in the region of the right cornu, where the wall was deep purple. The same appearances were present in the adjacent broad ligament and Fallopian tube. The appearances suggested an obstruction of the right ovarian vein. The placenta was detached over its right half by a large retroplacental clot, whilst its left half was still attached to the posterior uterine wall. The child was dead. On subsequent examination the uterus showed the appearances associated with "diffuse utero-placental apoplexy." The muscular wall was ploughed up by haemorrhage, the muscular fibres showing a secondary degeneration. The placenta presented an interesting appearance. The detached portion had a deep purple colour and was distinctly marked off from the healthy area. Microscopically the separated area showed the signs of early infarction which have been described by Dr. Young, namely, coagulation in the intervillous spaces and congestion and crowding of the villi. The liver and kidneys showed the changes characteristic of eclampsia.

Dr. DOUGLAS MILLER read a report of a case of placenta praevia associated with *post-partum* eclampsia. The patient, a 6-para, had been bleeding intermittently for a month and more or less continuously for a week. She was almost moribund on admission. She was six and a half months pregnant. The urine contained a trace of albumin on admission. Delivery was carried out by version. Next day headache and epigastric pain developed, and there was a heavy deposit of albumin in the urine. Forty hours after labour she had a convulsion, followed by coma from which consciousness was not regained. *Post-mortem* examination of the liver and kidneys showed the changes characteristic of eclampsia. The praevia portion of the placenta was greatly congested, and microscopically exhibited the features of recent red infarction. This case was consistent with the view that the toxæmia was dependent upon an absorption of poisons from the disintegrated portion of the placenta.

The PRESIDENT said that these cases seemed to lend support to Dr. Young's explanation of eclampsia. If this theory were correct, however, he wondered why toxæmia did not occur oftener.

Dr. CAMERON could not understand why one should have to deal so often with cases where there was obviously a partial detachment of the placenta or ovum, and yet there was an entire absence of toxæmia.

Dr. LACKIE asked Dr. Young how he would explain those cases where the amount of albumin remained stationary.

Dr. Young referred to the work which had been done in other clinics, and which, along different lines, lent support to the view that a severe toxæmia might be dependent upon

the absorption of the earliest products of tissue degeneration, a view which he had advanced in 1914. He cited especially the work of two French observers, who found that animals in which the uterine veins were ligatured for ten minutes died after a period of thirty to forty hours with signs closely simulating those of eclampsia. The fundamental point in his interpretation was that the amount of toxæmia varied directly with the degree of placental involvement. In some cases the toxæmia was slight, whilst in other cases it was severe. Even if the patient's life were not endangered there might be permanent damage of the kidneys. In support of his view he instanced the fact that Dr. Miller had found toxæmia of varying degrees in 60 per cent. of cases of placenta prævia.

PSYCHOLOGY OF HOSPITAL PATIENTS.

A MEETING of the Ulster Medical Society was held in the Medical Institute, Belfast, on March 10th, with the President, Dr. THOMAS HURSTON, in the chair. Mr. FULLERTON showed a case of deformity in a young child, and skiagrams of the case were thrown on the screen; the left femur was absent and the left leg was much smaller than the right.

Dr. W. CALWELL read "Notes on the examination of the mentality of patients in a general hospital." He referred to the exceedingly brief account given in the ordinary medical textbooks of the psychology of patients; a systematic and scientific case-taking was undertaken in some of the textbooks of insanity but was absent in those of general medicine. He described the later advances in cerebral physiology by Head and others, and the changes in psychology dating from Freud. A brief history was given, ending with Rivers's attempt to correlate the results of these two investigations with the manifestations of the psychoneuroses, especially as seen in the war. War experience supported Freud's mechanisms but negated his sex-instinct predominance. Owing to the large amount of work in the practical application of psychology brought about by the war and to the general interest taken in it by the public, it was very advisable that medical men should know the principles. The lay psycho-analyst was already here, and would do more harm than the bonesetter, osteopath, spiritualist, and Christian scientist. Dr. Calwell gave a tentative scheme to enable students and medical men to make a psychological examination of a patient.

Dr. MCKISACK and Dr. MARSHALL emphasized the necessity of making greater provision for these cases.

Surgery of Bones and Joints.

Mr. S. T. IRWIN then read a paper on some problems of orthopaedic interest exemplified by the surgery of bones and joints. He commented on the relative scarcity of such cases in the wards of general hospitals prior to the war, their prevalence subsequently, and the increased interest in this speciality generated by the work done for the benefit of the wounded soldier. There was thus not only a great extension in the type and number of diseases and deformities coming within the purview of the orthopaedic surgeon, but also many orthopaedic problems presenting themselves from day to day before the general surgeon. While this justified the claim of Sir Robert Jones that every orthopaedic surgeon should have a preliminary training in general surgery, it demanded as well that if the general surgeon was to exist as such in the future he must possess a training in the general principles of orthopaedics. The first problem dealt with was that due to fracture of the long bones. Excluding those fractures which were suitable for treatment by splinting, there was a smaller proportion demanding treatment by open operation. These might be subdivided into two main classes—(1) those requiring plating after the method of Lane, and (2) those requiring bone-grafting. Of these, Lane's method was more suitable for recent simple fractures with special deformities—for instance, spiroid fractures of the femur and tibia where accurate anatomical restoration was difficult to obtain by means of splints, and for simple fractures showing non-union due to the interposition of soft tissue between the fragments. Bone grafting, on the other hand, was essential for gap fractures where other operation, such as the step operation, was deemed inadvisable. Bone grafting was

rendered scientifically possible by the experimental work of Macewen, who in 1880 got tibial grafts to grow in a flail humerus, but to-day it gained its main advocacy from America, owing to the work of Albee and his followers. A number of lantern slides of fractures treated by each of these methods was used to illustrate the importance of selecting a particular method of treatment for a particular condition of fracture. The paper was illustrated by a series of lantern slides.

Reviews.

THE HEALTH OF THE INDUSTRIAL WORKER. In *The Health of the Industrial Worker*,¹ Professor E. I. COLLIS and Dr. M. GREENWOOD deal with the medical aspect of industry. As is pointed out by Sir George Newman in an introduction he has written for the volume, the ill health from which the worker in almost all trades and in all districts suffers is due for the most part to preventable maladies, and these in turn are largely attributable to the neglect of hygiene. The loss of time and energy thereby induced, though less impressive than that due to accidents and special occupational diseases, represents a much larger drain on industry. The economic side of industry is closely bound up with the medical side, for the most economical production can be obtained by employing a man only when he is at his best in mind and body, and under circumstances in which he can yield his maximum output of both.

No men better suited than the authors to the task they have essayed could be found, for their training and experience have been thorough, both on the practical and the theoretical side. The result of their efforts forms a compendium of the present state of knowledge which will prove invaluable, not only to the factory doctor, but to the welfare worker, the factory inspector, and the enlightened factory manager.

The book opens with an interesting historical summary of industry, and one cannot read without a shudder of the terrible conditions under which many industrial workers were compelled to labour a century ago. Thanks to more enlightened ideas and to industrial legislation, these conditions are now a thing of the past, but it is probable that few realize how much still remains to be done. The Report of the Ministry of National Service, issued last year, gave an inkling of the truth when it stated that only a third of all the men of military age in Great Britain could be classed as Grade 1, that is, as perfectly fit and healthy. In some industries, such as that of mining, the proportion was as high as 73 per cent., but in sedentary occupations, for example, tailoring, it was miserably low. Improvement in the conditions of industry on the lines indicated by the authors cannot fail to have a favourable influence on the physique of the workers.

In later chapters the authors deal with statistical methods and the health of the worker as indicated by vital statistics. A particularly valuable chapter treats of tuberculosis and industry. The effect of environment is discussed at some length, and it is pointed out that, whilst at ages over 35 the town dwellers die of phthisis at a much greater rate than the rural dwellers, the excess is far greater amongst males than amongst females. This excess is most marked at the age periods at which the largest proportion of urban males are in industrially employed, and the smallest proportion of industrial females—the age of married life. The authors surmise that industrial employment is a great factor in producing the difference, but they give reasons for thinking that, as a rule, the deleterious influence of factory life acts through the home environment. Vitality is lowered by adverse factory conditions, and the men in consequence succumb to evils associated with the home; whilst the women, who have not been rendered specially susceptible, escape. The incidence of another disease, cancer, likewise appears to be related to industrial conditions. The authors point out that the

¹ *The Health of the Industrial Worker*, by E. I. Collis, B.Ch., M.A., M.D. Oxon., M.R.C.P. Lond., M.R.C.S. Eng., and M. Greenwood, M.R.C.P. Lond., M.R.C.S. Eng. (Containing a chapter on Reclamation of the Disabled, by A. Collis, M.A., M.D. Cantab., M.R.C.S. Eng., D.P.H. Durh.; with an introduction by Sir G. Newman, K.C.B., D.C.L., M.D., F.R.C.P., Lond. J., and A. Churchill, 1921. (Roy. 8vo, pp. 462; 3s. 6d. net.)

sudden change which has taken place in the conditions of life consequent on the development of modern industry has been associated with a rapid rise of cancer mortality, and this rise is greatest where modern industry is most developed.

The practical aspects of factory work are treated of in useful chapters dealing with industrial activity and fatigue, with the causation and prevention of accidents, the feeding of the worker, and the provision of washing accommodation and cloak-rooms. The importance of adequate ventilation and lighting in the workshops is discussed at length, and many improvements are suggested. The industrial employment of women is dealt with in detail. In discussing the many obstacles to employment which have been suggested, the authors conclude that anaemia is benefited by regular occupation, whilst menstruation is not adversely affected by moderate physical work.

The book is for the most part very readable, and is lightened by occasional quotations from early writers. At times, it must be admitted, it is rather stiff reading, which the non-mathematical reader will find a little indigestible; but this defect, if defect it be, is almost inherent in the nature of the evidence it is desired to adduce. Occasionally, also, masses of tabular matter are printed which seem redundant. Take, for instance, the inadequately explained tables on pp. 366-372, dealing with labour turnover. However, these are minor blemishes, which do very little to detract from the many excellences of the book.

SURGICAL ASPECTS OF DYSENTERY.

MR. ZACHARY COPE has republished his Hunterian lecture in an amplified and extended form in a volume with the title *Surgical Aspects of Dysentery, including Liver Abscess*.² He has been encouraged to do this, he tells us, by the fact that the literature of the surgical aspects of dysentery is scanty, scattered, and not readily available. The result is an excellent little book, which covers the whole field of dysenteric disease very thoroughly. Whilst it is addressed primarily to the surgeon, the physician, too, would profit by reading it. Mr. Cope has no special axe of his own to grind, and the man who operates on every lump in the abdomen at sight will do well to take counsel of Mr. Cope, who is a restrained, conservative, and wise adviser.

Dysentery and its results had before the war mainly an academic interest. So many thousands of Englishmen, now safely in their homes, have suffered from this disease during the past six years that it behoves all of us who did not gain a first-hand experience of the subject in the East to repair the gap in our knowledge. For dysentery is essentially a disease which is not over in a day. Infection lurks behind; the smouldering fire is apt to break into a blaze.

The difficulty of diagnosing between an attack of acute oedematous colitis and appendicitis is well discussed. It is important to make a correct diagnosis, since operation on this type of dysentery is fraught with danger. We note that Mr. Cope prefers valvular caecostomy in chronic dysentery to appendicostomy, and thinks that it has a definite place in the therapeutics of this disease. Occasionally an open caecostomy may be called for, and even an ileostomy. Cases are quoted to illustrate the indications for these operations, which are only to be undertaken in special circumstances. In the section on liver abscess we are on more familiar ground; it is well written, and is illustrated by two admirable colour plates and some black and white drawings. The technique of needling the liver and of transpleural exploration is well described. The book is pleasant to read and convenient to handle.

APPLIED EUGENICS.

MR. PAUL POPENHOE, the editor of the *Journal of Heredity*, and Professor R. H. JOHNSON have conjointly produced a volume on *Applied Eugenics*,³ which admirably presents the eugenicist position. The book is a veritable mine of

information: it contains twenty chapters and six appendices, and it is fully illustrated. The facts and theories upon which the eugenicist bases his programme for racial betterment are clearly set out, and the means by which a superior type might be developed are fully indicated. In the earlier chapters the authors examine the contentions that environmental influences are capable of changing inherent characteristics, and that such changes can be transmitted in the offspring. In criticizing these views, the work of Galton on twins and statistical studies by Karl Pearson and others are utilized, and a chapter is devoted to the question of the modification of the germ plasm. The Lamarckian doctrine is discussed in relation to mutilations, diseases, results of use and disuse, and physico-chemical effects of environment, special attention being given to the problem of the influence of alcohol in the production of racial degeneracy.

Having developed the view that differences between human beings are due to heredity rather than the result of environmental influences, the question of the inheritance of mental capacities is approached. Here the psychopathologist comes in for a good deal of criticism. While we feel that he would have more to say in defence of his views than the quotations in this volume would seem to imply, yet in some instances there is undoubtedly a tendency to stress unduly the influence of environment in the production of mental disorder and to over-emphasize the possibility of prevention from this point of view. This being so, a little criticism of the too optimistic psychopathologist will do no harm.

Chapters are devoted to the consideration of the laws of heredity and natural selection, followed by an account of the origin and growth of the eugenic movement. Evidence is then brought forward as to the desirability and possibility of enforcing certain restrictions on marriage and parenthood. The classes of the community which could properly fall within the scope of such treatment are indicated, these being the insane, feeble-minded, epileptic, and criminal. The suggested methods of restriction are critically examined, and that of segregation is favoured as, amongst the coercive measures, the most generally practicable. Attention is given to the possibility of improvement in sexual selection, and the directions indicated in which it might become practically realized. Amongst other subjects discussed are the birth rate, race suicide, miscegenation between white and black, immigration, the effects of war on the race, and the defects and uses of the science of genealogy. Some of these questions are, of course, of more vital significance to the American people than to the European races. The influence, beneficial or the reverse, of current social trends on the aims of eugenics is discussed in relation to taxation, "back to the farm" movement, democracy, child labour, compulsory education, vocational guidance, minimum wage, bonuses, mothers' pensions, sex hygiene movement, prohibition, and celibacy of teachers. The concluding chapters are concerned with "religion and eugenics" and "eugenics and eutherics."

From this brief survey it will be apparent that this volume includes within its covers discussion on a wide range of social problems. However opinions may differ as to the methods by which these vital problems are to be solved, no one can afford to ignore their existence. The question of racial progress or decline should be the concern of every thoughtful citizen. There is an obvious need for an increasing number of "eugenically superior or desirable" persons in the community. Persons who will be capable of reproducing a type with the following characteristics: "To live past maturity, to reproduce adequately, to live happily, and to make contributions to the productivity, happiness and progress of society." The eugenicist offers tentative suggestions as to the methods by which such a desirable end could be achieved; and an aim such as this is entitled to respectful consideration. In this volume the case for eugenics is scientifically developed and clearly and temperately stated. We can thus thoroughly recommend it to all those who are interested in the question of racial betterment.

CLINICAL RADIOLOGY OF THE HEART AND AORTA.

THE first edition of Professor VAQUEZ and Dr. E. BORDET's *Le Coeur et L'Aorte: Etudes de Radiologie clinique*, appeared in 1913, a second was called for five years later,

²*Surgical Aspects of Dysentery, including Liver Abscess.* By Zachary Cope, B.A., M.D. M.S.Lond., F.R.C.S. Eng. London: H. Frowde, and Hodder and Stoughton, 1920. (Demy 8vo. pp. 167; 15 figures, 2 plates, 12s. 6d. net.)

³*Applied Eugenics.* By Paul Popenhoe and Roswell Hill Johnson. New York: The Macmillan Company, 1921. (Post 8vo. pp. xiii. + 459; 46 figures, 14s. 6d. net.)

and a third edition⁴ with additions, especially on pathological and senile dilatation of the heart, bears the date of May, 1920. This work is on much the same lines as, and supplements, *Radiologie des vaisseaux de la base du cœur*, by the same authors, which was reviewed in our issue of December 11th last (p. 896), and here again the 183 figures are reproductions of orthodiograph screen tracings and not of skiagrams. The radiological methods employed in studying cardiac and aortic disease are first described with a comparison of orthodiagraphy and telerradiography. The shadow cast by the normal heart in the various positions is then fully considered and the measurements thus obtained are illustrated by a number of tables and drawings, including one of the authors' goniometer. The various pathological conditions are then systematically dealt with, beginning with valvular disease. The clinical difficulties in diagnosing pericardial effusion are greatly diminished by the assistance of radiology; but it is not infallible, for pericarditis with a small effusion and a large heart may imitate cardiac hypertrophy, and conversely a dilated heart, especially as the result of alcoholic myocarditis, may produce a picture suggesting effusion. The decision whether or not Brauer's operation of cardiolysis should be performed can only, in the author's opinion, be determined by radioscopic examination. It is shown that the conditions necessary for the production of Broadbent's sign—systolic retraction of the chest wall between the eleventh and twelfth ribs at the back on the left side—are not only pericardial adhesions to the heart and the diaphragm but also to the chest wall in front; it may also be noted that the authors have observed this sign with widespread pleuritic adhesions without adherent pericardium.

The special characters of the enlarged heart of the aged are detailed, and it is pointed out that this condition may be found in persons who are comparatively young in years though the subjects of arterio-sclerosis and cardiac debility. The detection of aortitis is materially assisted and, indeed, in many instances made possible only by means of radiology. In making the diagnosis the measurements of the aorta are carefully taken and its pulsations, depth of shadow, and its contour are estimated; in so doing the influence of age must be taken into account. Orthodiagraphy renders it possible to watch the progress of aortitis, and to give a prognosis with greater accuracy than can be attained by the ordinary methods of physical diagnosis—for example, in cases of aortitis without dilatation, but with calcification, parts of the vessel, such as the descending aorta, that are normally invisible become obvious. The differential diagnosis of aneurysms of the thoracic aorta from other conditions, such as skeletal deformities, pulmonary consolidations, cysts, and tumours, is considered. This work, which is the outcome of extensive personal observation, closes with a chapter on the localization of projectiles in the heart and pericardium.

NOTES ON BOOKS.

A BOOK intended for "the use of medical students and practitioners" in India, as RAI BAHADUR JAISING P. MODI'S *Elements of Hygiene and Public Health*⁵ professes on its title-page to be, ought to present a clear exposition of the general principles of sanitary science, and of the application of these to the circumstances of the country and people for whose benefit it has been composed and published. Judged by this criterion the work under notice, of which a second edition has been called for within a "short space of time," is admirably adapted to fulfil the office of an educational textbook and an instructive handbook for the guidance of all concerned in the adoption of measures for the preservation of health and prevention of disease and death. The general chapters are well arranged and written, and contain full and accurate information. The chapters relating to schools, hospitals, industrial occupations, meteorology and climate, food and infectious diseases, take into account Indian conditions, and more special chapters concern village sanitation, fairs, famine camps, and poor-houses. Practical instruction, founded on

a knowledge of the requirements of these various subjects, are laid down in full and feasible detail. Several appendices, including model by-laws, and directions relating to water supply conservancy and other sanitary measures, are added. Sixty-seven illustrations constitute a helpful feature of the book. The arrangement, printing, and indexing are worthy of commendation.

*The British Journal Photographic Almanac*⁶ for 1921 is well described in its subtitle as a photographer's daily companion. It contains a directory of photographic societies and similar bodies, but its special value to the practising photographer is the long epitome of progress written by the editor, Mr. George E. Brown, F.I.C. The material, which is arranged under a series of headings, including apparatus, printing processes, and colour photography, is handled in a masterly manner. Convenient features are the collection of formulae for the principal photographic processes in use, and the series of tables containing data to which the photographer often has occasion to refer. The price has been raised, but it is still very reasonable.

In *The World of Sound*⁷ Sir WILLIAM BRAGG has collected in book form the six lectures he gave to an audience of young people at the Royal Institution during the Christmas holidays two years ago. The volume includes many illustrations, diagrammatic and otherwise, explanatory of the text, and a number of dainty head- and tail-pieces and vignettes, allegorical in intention, from the pencil of Miss Audrey Weber. The lectures provide a very agreeable introduction to this branch of physics; the lecturer's scope and method may be gathered from his headings: "What is Sound?" "Sound in Music," "Sounds of the Town," "Sounds in the Country," "Sounds of the Sea," "Sounds in War." In publishing them Professor Bragg has done his duty by the many youngsters and grown-ups who were not fortunate enough to hear his words and see his fascinating experiments, and it is of interest to note that several of the experiments were repetitions, using the same apparatus, of those performed in the same room by Tyndall half a century ago. The last chapter shows how "almost everything we have discovered about sound has found some application in the war."

⁴ London: Henry Greenwood and Co., Ltd. Sixtieth issue. (2s. net).

⁵ *The World of Sound*. By Sir William Bragg, K.B.E., D.Sc., F.R.S. London: G. Bell and Sons, Ltd. 1920. (Cr. 8vo, pp. 196; 93 figures. 6s. net.)

IRISH MEDICAL SCHOOLS' AND GRADUATES' ASSOCIATION.

THE forty-third annual general meeting of this association was held on March 17th (St. Patrick's Day) at Pagan's Restaurant, when Dr. Bulger resigned the presidential chair to Major-General WALLACE KENNY, C.B., A.M.S. (R.), who presided over a large attendance of members. The Chairman of Council, Dr. W. J. CORBETT, presented the annual report, in which it was stated that during the past year no less than three ex-presidents had died, Sir Charles Cameron, C.B., Dr. Phineas Abraham, and Sir James Dick, K.C.B., formerly Director-General R.N.

The festival banquet took place the same evening, when upwards of 100 members and guests (including several ladies) sat down, with Major-General WALLACE KENNY in the chair. After the loyal toasts had been duly honoured (the whole company standing up while they sang "God save the King") the Arnott Gold Medal was presented to Sir Berkeley Moynihan for his great achievements in surgery. In reply to the toast, "Our Guests," Sir BERKELEY MOYNIHAN said that all medical men with laudable ambition desired three things—namely: (1) To make competent provision for themselves and their families in declining years; (2) to attain the good opinion of their *compères*; and (3) to train younger men to do better than themselves work to which they had devoted their own lives. Nothing gratified himself personally so much as the kindly appreciation of his efforts to attain the last-named object. Continuing, he said that he was proud to claim as his countrymen so many who for generations had been among the foremost in art, in science, in research and professional attainments, to say nothing of those leaders in war and politics whose names were in the months of everyone during such times of stress as we had recently been passing through.

Other toasts were proposed by Dr. JAMES A. MACDONALD (President-elect of the Association), Dr. W. DOUGLAS, and Dr. GIBBINS FITZGERALD. The proceedings were much enlivened by songs and piano sketches.

⁶ *Le Cœur et L'Aorte: Études de Radiologie clinique*. By H. Vaquez, Professeur à la Faculté de Paris, et E. Gordan, ancien chef de laboratoire au Point à la Faculté de Médecine de Paris. Troisième édition. Paris: J. P. Baillière et Fils. 1920. (Roy. 8vo, pp. 264; 188 figures. 20 francs.)

⁷ *Elements of Hygiene and Public Health*. For the use of Medical Students and Practitioners. By Rai Bahadur Jaising P. Modi, I.R.C.P., and S. Edlin, I.R.F.P.S.G.S.S. Second edition. Calcutta and London: Butterworth and Co. 1920. (Demy 8vo, pp. 597; 67 figures. 13s. net.)

British Medical Journal.

SATURDAY, APRIL 2ND, 1921.

RESEARCH IN RADIOLOGY.

IN recording last week the circumstances of the lamented death of Dr. Ironside Bruce reference was made to the fact that evidence has accumulated supporting the opinion that a severe type of aplastic anaemia may be caused by the effects on the blood-forming organs of the more penetrating radiations, both from the *x*-ray tubes and from radium; the suspicion attaches more particularly to the most penetrating—the gamma rays. Very many of the early workers with the *x* rays suffered from a peculiar form of chronic dermatitis which, in not a few instances, developed malignant characters; mutilating operations became necessary, and the sufferer's long martyrdom often ended in death. The measures devised for protecting the skin from the rays greatly diminished the risks of this nature, but the suspicion then arose that constant working with radium or *x* rays had an injurious influence on the general health. Dr. Mottram, Director of the Research Department of the Radium Institute in London, ascertained that after a certain time definite blood changes occurred, the number of red corpuscles diminishing and the white corpuscles falling well below 4,000 in the cubic millimetre. The last report of the Institute directs that no nurse or attendant who habitually applies apparatus should work continuously for more than three months, and that this period should be followed by a change of occupation or a rest for another three months. It advises also that all the workers should have at least two clear holidays a week to be spent in the open air. It would appear that precautions of the same nature should be taken in dealing with the *x* rays.

The position is obviously very unsatisfactory; the precautions suggested are confessions of ignorance. Inquiry into the physics of both radium and the *x* rays has gone a long way, but the nature of the action of the rays on living tissues, healthy or diseased, is still very much a matter of guesswork, and the technology of the whole subject is in a backward state. The applications of radiology outside medicine are of growing importance; the *x* rays were used during the war for detecting flaws in the workmanship of aeroplanes, and are being applied to the examination of the internal structure of metals. It was, indeed, suggested a year ago that the memory of Sir James Mackenzie Davidson, who had himself suffered from the ill effects of the rays, could not be better commemorated than by the establishment of an institute for research and teaching in radiology. A Mackenzie Davidson Memorial Fund was accordingly established, and an appeal, signed by, among others, Sir J. J. Thomson, then President of the Royal Society, Sir Clifford Allbutt, President of the British Medical Association, Sir Robert Hadfield, recently President of the Faraday Society, and Mr. Bonar Law, was issued. To establish such an institute fully equipped to meet the needs of the metallurgist and the engineer, as well as of medicine, is an ambitious undertaking, and the increasing use of high tension *x*-ray tubes in hospital and private installations makes it urgently necessary to ascertain what precautions

can immediately be put into practice. It is, we are informed, proposed at once to appoint a committee to make certain investigations. It is hoped that the Röntgen Society, which did useful work in devising methods of protection early in the war, will join with the Electro-therapeutic Section of the Royal Society of Medicine and the British Association of Radiology and Physiotherapy in the nomination of such a committee, consisting of expert physicists, physiologists, and radiologists.

Dr. Robert Knox, who is secretary of the committee which last year appealed for the establishment of an institute, now proposes that the new committee of investigation should report on the equipment of *x*-ray and electrical departments with a special view to the protective measures to be employed, and should make recommendations for the guidance of the assistants in such departments, dealing in particular with the hours of work and the need for fresh air and change. But his proposals are also of a much more general nature, for he would instruct the committee to investigate the properties of *x* rays and the best means of controlling their action, and also the changes produced in tissues by *x* rays, and particularly the blood changes. Such a programme is too wide for any committee, and Dr. Knox himself perceives this, for he says that what is really required is the provision of research facilities on a large scale, including the equipment of an institute, and the endowment of research into the physical, technical, and biological properties of radium and *x* rays. It is true that the elements of such an institute exist in London. We have in the first place the Radium Institute; we have at the Middlesex Hospital a radiological department under the direction of a professor of radiology, who works in close association with the professor of physics and his department; we have also the research department of the Cancer Hospital, recently reorganized and extended under the direction of Dr. Leitch. It may prove to be possible as a temporary measure pending the establishment of an institute to draw up a programme of work to be divided between several institutions.

Hitherto the medical use of *x* rays and of radium has been far too empirical; we want to get down to basic principles, through the application of which the therapeutic use of these powerful agents may be guided, and their injurious effects prevented.

THE TRANSMISSION OF MEASLES TO MONKEYS.

THE prevention of measles is still an unsolved problem, for attempts to attain this end by strict quarantine are commonly frustrated by the infectivity of patients in the prodromal stage of the disease. Prevention by prophylactic inoculation is a theoretical possibility, but obviously it must be preceded either by the isolation of the virus or the elaboration of a satisfactory method of obtaining it in a pure form, whether or not it is definitely identified microscopically and culturally. Efforts to obtain the virus by cultural methods have so far failed to give positive results; and, though much work has been done by Hektoen, J. F. Anderson and Goldberger, and Sellards on the transmission of measles from man to monkeys, the results have been inconclusive. Blake and Trask,¹ of the Hospital of the Rockefeller Institute for Medical Research, have therefore felt it desirable to carry out an extensive investigation to decide this question. They employed a method that promises the best

¹F. G. Blake and J. D. Trask, junior: *Journ. Exper. Med.*, Baltimore, 1921, xxxiii, 365-422.

opportunities for the successful transmission of the virus—namely, the introduction of a comparatively large amount of the material believed to contain the virus by the natural pathway of infection: accordingly unfiltered nasopharyngeal secretion from patients in the very early stage of the disease was injected intratracheally into monkeys (*Macacus rhesus*). The question whether the disease had been transmitted was decided, as in the clinical diagnosis of measles, by the appearance of the characteristic symptoms and lesions of the disease. Out of ten monkeys inoculated intratracheally eight developed symptoms closely resembling those of measles in man, after an incubation period of from six to ten days; this afforded presumptive evidence that the reaction in the monkeys was due to the virus of measles. That the reaction was not due to the common organisms of the mouth present in the unfiltered nasopharyngeal washings is shown by the occurrence of the same reaction after the inoculation of the fluid when freed from ordinary bacteria by filtration through a Berkefeld-N filter. The possibility that the reaction was due to filtrable toxic substances in the nasopharyngeal secretion of patients suffering from measles is also excluded by the successful transmission of the infection through six series of monkeys by means of emulsions obtained from the skin, buccal mucous membrane, and the viscera of these animals. Citrated whole blood from monkeys seven to thirteen days after intratracheal injection of the donor monkeys caused the symptoms of measles, but cultures of this blood made in various ways, aerobic and anaerobic, did not show any growth.

The incubation period in the experimental monkeys was usually seven days when the virus was introduced into the trachea, but after intravenous injection of citrated blood the interval was apparently shorter (four days); this difference, it is thought, may be explained by the elimination of the period that probably elapses between the introduction of the virus into the air passages and the invasion of the blood. The onset is attended by malaise, diminution in the leucocyte count, conjunctival injection, and by the appearance of small discrete hyperaemic macules on the labial mucosa and inside of the cheek, which eventually coalesce, and may or may not show the minute bluish-white centres characteristic of Koplik's spots. From one to several days, usually on the third or fourth day after the onset, a characteristic exanthem of maculo-papules appears on the skin, and as a rule first on the face; it is rarely as widespread or as thick as in man, but it runs a similar course; and by the sixth to the tenth day after the onset the animal is well. A careful microscopical examination of the skin, labial mucous membrane, and tongue showed an exact similarity between the changes in man and those in the experimental monkeys. The fact that the average duration of the incubation period in monkeys is three or four days shorter than in human measles may, it is thought, reasonably be explained by the large quantity of virus injected into the trachea.

The only conspicuous difference between the human and the experimentally produced measles is the absence of the respiratory complications in the experimental infection; the authors cannot at present explain this difference, but they argue that it should not be held to constitute a valid reason for rejecting the belief that the reaction observed in the monkeys is caused by the virus of measles. Further observations on the virus and on the problem of protective vaccination will no doubt follow from the Rockefeller Institute and its attached hospital.

BILHARZIA DISEASE.

We seem now to have the story of bilharzia disease complete, at least in its broad features: The adult worm comes to maturity in man; the intermediate host is a fresh-water mollusc; man is infested again through the skin and can be cured by antimony. The disease has been one of the scourges of Egypt for at least 3,000 years; the late Sir M. A. Ruffer, in a paper published in our columns of January 1st, 1910, described it from the kidney of a mummy of the twentieth dynasty (1250 to 1000 B.C.). The disease is known to exist to-day in most parts of Africa, especially Egypt and the Cape, in Madagascar, Mauritius, Cyprus, the West Indies, Guiana, and Brazil. It is due, as is well known, to infestation by a trematode, *Schistosoma haematobium*, discovered by Billharz in Cairo in 1851. The mature worm occurs in the portal system of man, and the usual course of events is that the male and female travel conjugated down the anterior mesenteric vein to the wall of the bladder, whence eggs find their way into the urine. Much more rarely the parasite attacks the kidney and the intestines. The egg, when it reaches the urine, already contains an active ciliated miracidium which, when the egg reaches water, is liberated. Leiper showed by systematic inquiry in Egypt during the war that the miracidia enter certain species of fresh-water molluscs (in Egypt *Bullinus* and *Planorbis*). They may be seen swarming round individuals of these species but avoiding other species; they quickly disappear into the snails and establish themselves in the liver; there they form sporocysts from which cercariae are eventually liberated and reach the water; they are free swimming bodies; they infect man through the skin or mucous membrane of the mouth and throat. Theoretically it would be possible to control bilharziasis by breaking the life-cycle at any point. Leiper suggested a campaign in the summer, when the canals and drains are low, against the mollusc intermediate host; this would call for operations on a large scale, and co-operation with the farmers and cultivators would be necessary. The suggestion made by Dr. Christopherson, in a paper published at p. 491, is that a great deal might be done not only to relieve suffering, but to prevent the extension of the disease, by placing facilities for treatment at the disposal of inhabitants of the country districts by travelling dispensaries. The value of treatment of the disease by intravenous injections of antimony tartrate is now well recognized by medical opinion, and the results are so excellent that in Egypt sufferers are spontaneously applying for treatment in large numbers. Drs. Lausbury and Coleman were able to report the results of 1,000 cases in our issue of February 26th, p. 299; they used injections of antimony tartrate given in the manner recommended by Dr. Christopherson a couple of years ago. It is very possible that other salts or preparations of antimony may prove more convenient, and Dr. Cawston is working on this and other aspects of the subject in Durban. Recently the Minister of Health for South Africa, Sir Thomas Watt, informed Dr. Christopherson that the authorities intend to bring the antimony treatment of bilharzia to the notice of all concerned.

THE NUTRITIVE VALUE OF LARD.

THE enormous quantities of pig fat converted into lard for human consumption may be judged from the fact that in 1912 the weight of lard exported from the United States alone was over 500 million lb. The importance of a knowledge of its nutritive value is obvious, and we need, therefore, make no apology for recurring to the subject. Since 1913, when McCollum and Davis started the examination of various fats for the presence of the accessory substance known as vitamin A, and found none in lard, it has been generally assumed that the pig, unlike other animals, is peculiar, and does not store this valuable

food factor in its fat. Osborne and Mendel, two years later, carried out a single experiment to ascertain whether this is due to the technical processes to which the pig's fat is subjected in preparation for the market, but found that their own product, "laboratory lard," was equally inadequate for growth. This experiment must be regarded as of little value, as no test with unheated pig's fat appears to have been made. The mystery why the pig should form an exception to other animals has now been finally cleared up by the work of Dr. J. C. Drummond and his colleagues. Their paper¹ contains much of technical interest in relation to lard manufacture, and, as we have previously pointed out, shows to what drastic treatment the fat is subjected in order to produce the white product which appeals to the purchaser. The experimental pigs were reared on various diets, some containing the fat-soluble vitamin and others destitute of it. The photographs of the carcasses when the animals were killed are striking and convincing. One remarkable feature in the pig is the considerable growth which takes place early, even on a diet destitute of the vitamin. This is to form the subject of further work. In all cases, however, growth ceases sooner or later, and thus the necessity for the vitamin is proved. It is well known that animals cannot synthesize it for themselves, but rely on the plant world for its presence, and the green portions of vegetables form the main source of supply. The pig is usually reared on toppings (wheat pollards) and whey, which are cheap, being waste products; both are practically destitute of the vitamin; their fat, even without treatment, contains none. But if they are grass-fed in addition, then they store the vitamin in their body fat. The low nutritive value of lard is therefore due to two causes: first, the erroneous feeding of the pig; and secondly, the destruction of any vitamin which might be present in the natural fat owing to its exposure to oxidation at high temperatures during its subsequent treatment. Reform is therefore called for in two directions: first, the farmer must be instructed to feed his pigs on a more natural diet; and secondly, the public must not insist on a product which appeals merely to the eye. The so-called refining of foods may often refine away a valuable ingredient. A striking illustration of this has been recently shown to occur by Dr. Zilva in reference to the fat richest of all others in vitamin A—namely, cod-liver oil. The discovery that this vitamin is destroyed by oxygen at elevated temperatures renders necessary a reinvestigation of the question whether vegetable oils are really destitute of the vitamin. Those on the market are; but here again processes of refining may be in part responsible for the result.

MALARIA IN ENGLAND.

The malaria problem in England is interesting not only from the practical but from the historical point of view, and further light may be thrown upon it by a study of the part played by meteorology. This point was emphasized by Angus Macdonald,² who has published detailed temperature statistics for 1858-1860, the last occasion on which malaria is known to have prevailed extensively in England. The year 1858 was noteworthy for an exceptionally long and hot summer, the Registrar-General reporting: "The heat in June was so great that there was no instance since 1771 in which the mean temperature for that month had been exceeded." Malaria is indigenous in certain parts of England, and of the three English anophelines *A. maculipennis*, which is known to be present in nearly every rural district and in or near almost every town in England, is believed to be responsible for nearly all the cases of the disease. Since the war the interest in malaria in this country has naturally greatly increased, as many practitioners have had a large experience of the treatment of the disease both abroad and at home, and also because the

danger of contracting it from the presence of relapsing cases among soldiers returned from the East caused the disease to be made notifiable. Statistics, moreover, show that no fewer than one army pensioner in every thirteen is being pensioned because of malaria. The influence of temperature and humidity on malaria in England forms the subject of a valuable paper by Brevet Lieut.-Colonel C. A. Gill, I.M.S., in the *Journal of Hygiene* of January last, following his investigations on the same subject in regard to India. He considers that relative humidity, being at all times favourable, plays little or no part in determining the seasonal incidence of malarial infection in England; but the temperature factor plays an important part, since it limits the period during which malaria may ordinarily be acquired in the United Kingdom to the months of July and August. To test the accuracy of this view Colonel Gill prepared a map of England, differentiating the areas having mean temperatures during July and August of (1) 62° F. or over, (2) 61-62° F., (3) 60-61° F., and (4) under 60° F. The distribution of temperature during the hottest months of the year, as measured by monthly mean temperature, was found to be in some respects peculiar, and differed from the distribution which on general grounds might have been anticipated. The area showing a mean temperature during July and August of 62° F. or over is extremely small, and comprises a strip of country in Essex and Kent on each side of the estuary of the Thames and the lower portion of the Thames valley. Included also is a strip of country in the south of Hampshire, near the New Forest, together with the eastern portion of the Isle of Wight. The towns of Brighton and Clifton also belong to this area. Area 2, which is much larger, extends on the south from near Dover to the west of Bournemouth, while the northern boundary runs obliquely across England from a point on the east coast of Norfolk to the Bristol Channel near Cardiff. The western boundary runs due north from near Bournemouth, then turns west and runs parallel to the Bristol Channel, and ends in the neighbourhood of Ilfracombe. Belonging to this area are small districts surrounding Torquay, Teignmouth, and Plymouth. Area 3 consists of a strip of country lying to the north of and parallel to Area 2 except in the east, where the northern boundary diverges so as to include an area in the south of Yorkshire. The estuary of the Dee and a small district along the north coast of Wales also belong to this area, while a district around Shrewsbury, the south coast of Devon, and three small coastal districts in Cornwall are included. Area 4 comprises the remainder of England and Wales with the exception of Manchester and Aberdovey, and the whole of Scotland and the whole of Ireland with the exception of the city of Dublin. In this area the mean monthly temperature during July and August—the hottest months—never normally reaches 60° F. During the period 1917-1919, 404 indigenous cases of malaria were discovered in thirty-nine different localities in the United Kingdom, according to the statistics of the Local Government Board and the Ministry of Health. On allotting to their respective areas the localities and the number of cases occurring in each, it is found that 40 per cent. of the endemic localities and no fewer than 86.6 per cent. of the cases are included in the extremely small zone of Area 1, while 40 per cent. of the localities and 10.4 per cent. of the cases are scattered throughout the larger Area 2. There are eight localities, or about 20 per cent., and 12 cases in Area 3, while no endemic localities and no cases exist in the rest of the United Kingdom. Of the thirty-nine endemic localities, seventeen are situated on the coast, and if those are included which are less than 100 feet above sea level and are at the same time in close proximity to the coast, no less than 65 per cent. of the endemic localities exhibit the climatic conditions prevailing in coastal regions during the summer. All the remaining inland endemic centres are in low-lying situations close to

¹ *Biochemical Journal*, 1920, xiv, p. 742.

² *War Office Observations on Malaria*. December, 1919.

river valleys or marshland, such as the Fen district. Colonel Gill suggests, therefore, that the precise location of the endemic centres of malaria in England within the area of favourable mean temperature may be partly explained by relative humidity. It has been shown by James that in a number of places in England which harboured many carriers and numerous anophelines no new case of malaria arose ("paludism sine malaria"), and also that some of the new cases recorded arose in areas which harboured only one to two carriers and exceedingly few anophelines ("malaria sine paludism"). Colonel Gill thinks that the explanation of these two conditions may be found in the part ascribed to the temperature and humidity factors, as it is clear that in England, if the temperature during July and August is unfavourable to the transmission of malaria, the local incidence of the disease will not be affected by the presence of many human carriers and numerous anophelines; while, on the other hand, in areas where the temperature and humidity factors are favourable, the transmission of infection will be apt to occur, provided one or two carriers are present together with relatively few anophelines.

ALEXIS SOYER.

UNDER the title "Alexis Soyer, a Chivalrous Chef," Captain J. S. Taylor,¹ Medical Corps, United States Navy, gives a full and interesting account of the self-sacrificing efforts of the leading chef in London, who had presided for ten years over the kitchens of the Reform Club when, in February, 1855, he volunteered to go gratuitously to organize the feeding of the patients at Scutari. This was not the first occasion on which he had shown his public spirit, for during the Irish famine of 1846 he conducted an open-air kitchen outside the Dublin barracks, where between four and five thousand people were fed daily at a nominal charge, and facilities were available for double that number in his kitchen near the South Union Workhouse. His name was familiar on account of his popular shilling cookery book, his *Modern Housewife*, and the "relish" he invented. When he got to the Crimean war zone, with his staff of eight assistants, he worked wonders, for not only were the diets transformed, but far-reaching economies were effected. He was the originator also of the Soyer stove, a common object in every military camp at the present day. Miss Nightingale, to whom he was devoted, subsequently wrote: "His death is a great disaster. Others have studied cookery for the purpose of gormandizing, some for show, but none but he for the purpose of cooking large quantities of food in the most nutritious manner for great numbers of men. He has no successor. My only comfort is that you were imbued before his death with his doctrines and that the Barracks Commission will now take up the matter for itself." At the conclusion of the war, before leaving the Crimea, he bought the wicker carriage which had been constructed for the use of Miss Florence Nightingale in her ceaseless errands of mercy throughout the widespread area occupied by the besiegers of Sebastopol and brought it to England, where it is still preserved. The "Great Soyer," as he was commonly known in the Crimea, must have presented a remarkable appearance in the costume he adopted; in a dialogue between the *Times* correspondent and John Bull, who was supposed to have visited the camp, the question was asked, "Who is that foreign officer in white bournous and attended by a brilliant staff of generals—him with the blue and silver stripes down his trousers, I mean, and gold braid on his waistcoat and a red and white cap? It must be Pelissier?" The answer follows: "That! Why, that's Monsieur Soyer, chef de nos batteries do cuisine." Thackeray is supposed to have portrayed him in *Pendennis* (1850) as Alcide Mirobolant, who conveyed his love messages to his employer's

daughter, Miss Blanche Amory, in the language of culinary creations, but this would appear to have been a gross caricature of a noble personality.

OPHTHALMIC WORK IN EGYPT.

THE seventh annual report, for 1919, of the Ophthalmic Section, Department of Public Health, Ministry of the Interior, Egypt,¹ shows that the new patients numbered 76,525; nearly 50,000 operations were performed, and the total attendances of out-patients were 906,961. As the staff were short-handed during the year owing to the war, the work must have been very arduous, and the director, Dr. A. F. MacCallan, and his assistants are to be congratulated on the results of the year's working. The seasonal variations of the different organisms did not differ much from what has been observed and recorded in former reports; during the summer a vastly greater number of patients present themselves for treatment than in the winter. This is mainly due to the increased amount of acute conjunctivitis present in the summer; but neither atmospheric humidity nor differences in the level of the Nile seem to bear any relation to the increased incidence of conjunctivitis. Dr. MacCallan believes that flies do not play a great part in the transmission of eye diseases; he acknowledges that more light needs to be thrown on the habits of the flies of Egypt, and notes that an entomological investigation of these points is now being carried on there. The gonococcus is the main cause of the increase of acute cases of conjunctivitis, but it is curious that the upward trend of the gonococcal curve continues longer than that of the temperature; the maximum temperature is in July, while the summit of the gonococcal curve occurs in October. It is interesting to observe the marked differences between the gonococcal conjunctivitis of Egypt and that of Europe; in the latter the contagion is usually venereal in origin, but in Egypt it is acquired from eye to eye. In Egypt it is often met with in a subacute or chronic form, and the disease appears to be less destructive to the eye than is the case in England. Can these differences, the Director asks, be due to the fact that the organism of Egypt is not the gonococcus at all, or is it less virulent than the British gonococcus? An investigation of this question has been begun at Giza, and it is to be hoped that it may be continued. More than 12,000 patients examined during the year were found to be blind in one or both eyes, and 4,000 of these were completely blind. Signs of simple glaucoma were found in 2 per cent. of all cases seen during the year, the number of operations performed for this disease amounting to 749. Of senile cataract, nearly 1,500 cases were seen, but as so many of these eyes had been previously spoilt by the complications of trachoma and acute conjunctivitis, the number of extractions performed only reached the "modest" total of 364. Lastly, we may note that, as should be expected from the wealth of clinical material at its members' disposal, the Ophthalmological Society of Egypt is in a flourishing condition, and it has been affiliated to the Ophthalmological Society of the United Kingdom.

INTERNATIONAL RED CROSS CONGRESS.

THE tenth International Red Cross Congress was opened at Geneva on the afternoon of March 30th; the number of subjects set down for discussion is so large that it will be continued until April 8th. Reports on certain funds and on the allocation of the Nightingale medal will be presented by the International Red Cross Committee, which has arranged the order of business. Various questions arising out of the experiences during the recent war will be debated, in particular the insufficiency of existing conventions concerning prisoners of war (military and civil). Other subjects for discussion come under the general

¹ The Seventh Annual Report of the Ophthalmic Section, 1919. By the Director of Ophthalmic Hospitals. Cairo: Government Press, 1920.

¹ *United States Naval Medical Bulletin*, 1921, xv, No. 1.

heading of the relations of the various international Red Cross organizations to each other and to other philanthropic associations in peace as well as in war. The establishment of training schools for nurses and the organization of district nursing in peace will be discussed. A proposal will be made to revise the Geneva Convention in order to add to it a series of articles defining the status of ambulance aeroplanes and airships, and the protection which should be accorded to them when engaged in the transport of sick and wounded in time of war.

MATERNITY AND CHILD WELFARE CENTRES AND DAY NURSERIES.

IN view of inquiries from local authorities and others interested, the Ministry of Health has issued a revised list,¹ with index, of maternity and child welfare centres in England and Wales, including, for the first time, a list of day nurseries. The list contains the names and addresses of 735 centres and 140 day nurseries conducted by voluntary societies, and of 1,188 centres and 44 day nurseries conducted by local authorities. At about 150 of the centres special dental treatment is provided, while others have special arrangements for eye and ear treatment. The centres in the first part of the statement are primarily consultation centres for nursing mothers and children under 5, but some are fully equipped for ante-natal consultations. There are now separate lists for residential and non-residential institutions. The Ministry of Health advises that consultation centres should be reserved for healthy women and children, and that, where possible, treatment should be given at special treatment centres, which may be established at a hospital or combined with a school clinic, and may take cases from a number of consultation centres.

WE publish a Current Note in the SUPPLEMENT this week giving the dates on which the several two-day and one-day Scientific Sections will meet at the forthcoming Annual Meeting of the British Medical Association at Newcastle-on-Tyne.

WE regret to announce the death of Mr. R. J. Pye-Smith, F.R.C.S., Consulting Surgeon to the Sheffield Royal Hospital and Emeritus Professor of Surgery in the University of Sheffield.

WE have to announce also the death of Dr. R. Murray Leslie, physician to the Royal Hospital for Diseases of the Chest, which took place in London on March 29th.

Medical Notes in Parliament.

Maternity Welfare Administration.

Statement by the Minister of Health.

IN the course of the debate on the Consolidated Fund Bill, on March 22nd, Dr. Addison took up questions as to the position of the Government in regard to recommendations of the Washington Convention as affecting maternity welfare. Under Article 405 the authority to determine whether legislation should be initiated was the Crown and its executive. If the matter did not rest thus it would mean that a body meeting in Washington could compel the British Government to submit legislative proposals to Parliament against its desire. If the Government submitted proposals, the action must carry the assumption that the Government approved of it. On the other hand, members were aware that an opportunity would arise, and had practically arisen, for attention to be called to the decision of the Government. The proposals of the Washington Convention were that the Government should pro-

vide for the six weeks preceding and the six weeks following confinement; that during the first-named six weeks the woman should be compelled to be absent from work, and that during the six weeks following confinement, and while she was absent from work, the woman should be paid out of the public funds, or by a system of insurance benefits should be paid sufficient to provide for full maintenance, free attendance, and for a doctor or a certified midwife. These were the recommendations relating to employed women. There was in our own country a system doubly capable of dealing with these questions. They had an Insurance Act which provided maternity benefit for women who were themselves workers or the wives of employed contributors. They had parallel with that, and administered by local authorities, a system for giving assistance, advice, and so forth in connexion with maternity and child welfare generally. The Washington recommendation would cut right across that system, which had been gradually built up in this country far in advance of what had been done in any other country. That was one reason for not adopting the recommendations. The British Government had acted in advance of these recommendations with singular success and with much greater economy than such proposals would permit. In this country there would be 400,000 women who would be eligible for these benefits. The British system provided that not only the women employed, but the wives of employed contributors, although not themselves employed, should benefit. The Washington recommendations would automatically exclude 3,540,000 women who were the wives of insured persons but not themselves employed contributors. The recommendations would be applicable to only about one-ninth of the married women of a particular class in our country. The Government had done something for the remaining eight-ninths. If the recommendations were adopted and applied to the employed women only they would cost about £1,700,000 a year. A system of this kind could not conceivably be limited to this small section of women of the industrial classes. It could not properly be limited to employed women only, and this was of an impracticable character. So soon as the system was in operation the working man whose wife did not go out to work would say, "My wife is as much entitled to this benefit." That would apply to eight-ninths of the married women of this country, and would cost an additional 15 millions sterling. He did not think, in view of our other services, the country required an expenditure to anything like such an amount. A table which he had supplied to Captain Elliot showed that the average expenditure for maternity and child welfare was rather less than a penny in the rates, and the total provision out of the Exchequer was rather less than 1s. 5d. in the £. The total from the Exchequer was about £900,000, and the total for all authorities a little less. There was now established a great system of maternity and child welfare centres throughout this country—nearly two thousand of them, with about 3,500 trained nurses and visitors. They had established a large number of maternity beds in houses where women who lived under bad conditions could be properly attended to on payment of a nominal fee. It was a system which had developed on lines quite different from those of the Washington Convention. The results were brilliant; no other word was adequate to describe them. During the past two or three years there had been a conspicuous absence of a bad epidemic; people had been better fed than before, and since the war there had been a greatly awakened conscience on these matters. He asked the House to note the child death rate for London. In 1913 it was 106; in 1917 it was 104; in 1918 it was 108. In 1919 the rate fell to 85 and in 1920 to 75. The child death rate for the greatest city in the world had been brought down in that remarkable way.

Mortality from Tuberculosis.

Dr. Addison, on March 23rd, informed Captain Elliot that the total deaths during the past six years (from 1915-1920 inclusive) from all forms of tuberculosis were as follows: 54,295, 53,858, 55,934, 58,073, 46,312, 42,545. The death rate per hundred thousand of the population for the same years were as follows: 151.5, 152.9, 162.4, 169.4, 125.8, 112.8. The figures for the last two years were the most encouraging we have had since the inception of the national scheme for the treatment of tuberculosis.

University of London Site.—Sir W. Davison asked, on March 24th, whether the agreement by the Government to purchase from the Duke of Bedford some eleven acres at the rear of the

¹Obtainable from H.M. Stationery Office or through any bookseller. Price 2s. net.

British Museum was made by the duke conditional on the land being used for the erection of new buildings by the University of London; whether there was a clause that, in the event of such buildings not being erected by April, 1926, the duke should have an opportunity of repurchasing the property at the price which had been paid for it by the Government; whether the Government were consequently precluded from using the site for any other purpose than for the erection of university buildings; whether the site had been definitely purchased by the Government subject to the above-mentioned restrictive covenant; and whether a copy of the agreement would be laid on the table of the House of Commons. Mr. Baldwin replied that the agreement contained a clause under which, if before April 1st, 1926, the Government gave notice that they found it impossible to use the property, the vendor would have an option to repurchase it for the price given, and if he did not exercise the option, the restriction of the use of the site for the purpose of the university would be removed. It was therefore not the fact that the Government would be precluded from using the site for any purpose other than that of university buildings. Mr. Baldwin promised to inquire whether the duke's trustees would have any objection to the presentation of the agreement. Sir W. Davison asked if it were not a fact that the Government was precluded from using the site for other than university purposes seeing that the duke had an option for repurchase if it were to be used for other than university purposes. He repeated the question whether the site had been actually purchased. Mr. Baldwin said he thought that it had been purchased. If the duke repurchased, the question of use for other than university purposes would not arise. If he did not repurchase the Government would not be precluded. In the improbable event of the abandonment of the scheme it would be for the Government of the day to determine whether to dispose of the site or to devote it to other purposes. Sir W. Davison asked whether the Minister of Education was aware that in his letter to Lord Rosebery the statement was definitely made in urging the university to give an early reply that in the event of the university not requiring the site it was required for other purposes, would it be stated for what other purpose the Government required a site of eleven acres? No reply was given.

Propaganda to Check Venereal Disease.—Dr. Addison, replying to Captain Elliot, on March 23rd, said that in accordance with the recommendation of the Royal Commission on Venereal Diseases, the National Council for Combating Venereal Diseases had been recognized by the Government since 1916 as the authoritative body for the purpose of spreading knowledge and giving advice in regard to the question of venereal diseases in its varied aspects. During the years ended March 31st, 1919, and March 31st, 1920, grants were made to the National Council from the Exchequer amounting to £13,000 and £15,000 respectively, and the grant up to date during the current financial year amounted to £13,750. These grants had been paid in respect of expenditure incurred by the National Council in connexion with a campaign of publicity and education, by means of lectures, meetings, exhibitions, and press advertisements, and by pamphlets, posters, and other literature. The grants for the current financial year included a proportionate sum for administrative expenditure. No grants were made direct by local authorities to the National Council; but some of these authorities had made contributions to the local branches of the Council in aid of propaganda and educational work undertaken by those branches. Captain Elliot asked whether, in view of the recent recommendations of the Birth Rate Commission, the Minister of Health would see that steps were taken to persuade the two societies engaged in the campaign against venereal disease to co-operate instead of pulling in different directions. Sir J. D. Rees: Will the right hon. gentleman in this matter regard with suspicion the reports of a profession which has reported that victorious England has a 63 population? Dr. Addison could not agree with the generalizations. He had done everything he could to get the two different bodies to work together, and was continuing to do so.

The Waiting Work of Appeal Tribunals.—The Attorney-General, on a question by Lieut.-Colonel Sir F. Hall, on March 21st, said that pensions appeal tribunals were distributed in various large centres in England and Wales (including London) according to the number of cases to be dealt with in such centres, this number varying from month to month. Since February 28th six tribunals had been sitting in London. Approximately 3,000 cases await hearing in London; of these 1,565 have been received by the tribunals during the last month. Up to the present time the average period elapsing between the date on which an appeal was received by the tribunal and the date on which it was listed for hearing had been (he understood) six weeks. Steps for setting up additional tribunals were under consideration.

Appeal Tribunal Cases.—Sir Gordon Hewart stated on March 22nd, in reply to Mr. Gwynne, that the total number of cases awaiting hearing by the pensions appeal tribunals for England and Wales was 7,850, of which approximately 600 were cases in which the appellants had already been afforded one or more opportunities of having their cases heard but had failed to attend. The tribunals for England and Wales were hearing cases which reached them at the end of January and in the early part of February last. Two extra tribunals had recently been set up, and owing to the continued large increase in the number of cases received, the appointment of further tribunals was under consideration.

Coroners' Remuneration Bill. Mr. Lloyd George, on March 24th, informed Major Steel that the Government did not oppose the second reading of this bill, but it must take its chance with other private bills.

Ex-Servicemen in Lunatic Asylums.—On an inquiry raised by Mr. Raper, on March 23rd, as to the detention of an ex-service man in Claybury Asylum, Dr. Addison said that the patient was interviewed by a medical commissioner of the Board of Control and a medical officer of the Ministry of Pensions, and it was decided by the Ministry of Pensions after the fullest consideration that the man had not yet sufficiently recovered for removal to a neurological hospital. There were about 4,673 ex-service patients in asylums in England and Wales, and their mental condition was constantly under review. Mr. Raper put it to Dr. Addison that as recently as December 3rd he had informed the House that so far as he could find out there was no definite information as to any ex-service men suffering from shell shock being kept in pauper lunatic asylums. Dr. Addison believed the statement was still correct, but shell shock did not include all forms of mental disability. It might be that this man was originally sent to the asylum as suffering from shell shock.

Blind Persons Act.—Mr. G. Edwards asked, on March 24th, whether instructions had been given by the Customs and Inland Revenue to pension officers to oppose the grant of any pension in the absence of a certificate of blindness from an institution for the blind or other similar body; whether, in fact, any certificate from a medical man or other satisfactory evidence was not sufficient to justify the grant of a pension; whether the attention of the Ministry of Health was called to this matter by the Norfolk Local Pensions Committee in November last, with special reference to cases where medical certificates had been obtained stating that the claimants were too blind to do any work for which eyesight was essential; but nevertheless the pension officer had opposed the grant of a pension. Dr. Addison said that it was in pursuance of regulations made under Section 10 of the Old Age Pensions Act that the instructions for carrying out the Old Age Pensions Act were framed. These instructions required the pensions officer, in the absence of a certificate from an institution for the blind or similar body, to appeal against the allowance of any claim unless he was personally satisfied that the claimant was totally blind. Arrangements had been made in the Ministry of Health for assessing any medical evidence which was produced by the claimant, and, where such evidence was lacking or inconclusive, for medical examination of the claimant. He had received representations from the Norfolk Pensions Committee such as was indicated in the question and was looking into the whole matter.

Optical Glass Industry.—The position of the optical glass industry has been the subject of careful consideration in connexion with the proposed bill in the safeguarding of certain industries. This was stated by Sir Philip Lloyd Greamé on an appeal that the trade should be made "a key industry."

Opium Cultivation in China.—Replying to Sir J. D. Rees, on March 23rd, Mr. Montagu said it was not proposed to make any change in the opium policy of the Government of India as a result of the recrudescence of poppy cultivation in China. The matter was now governed by the Hague Convention, under which as China had prohibited the import of opium, India was bound to prevent the export of Indian opium to China. Sir John Rees put it that the prohibition by China of the import of opium was merely an empty form. Mr. Montagu said the matter would be discussed by the Opium Advisory Committee of the League of Nations at the forthcoming Congress in Geneva.

Condensed Milk: Draft Regulations.—Dr. Addison said, on March 24th, in reply to Mr. Doyle, he understood that the standards recommended by the Committee were not substantially different from those which were advocated by the majority of trade witnesses, except in the case of full-cream unsweetened, where a somewhat lower standard had been adopted. He was prepared to publish the Committee's report if there was any general desire for it.

Grants for Health Services.—The grants paid to local authorities in London during the last completed year in respect of health services were as under: Tuberculosis, £49,195; maternity and child welfare, £39,763; venereal disease, £35,543; total, £124,501. The total expenditure in all these services combined was 2½d. out of an average rate for London of 14s. 5d. for the year.

The Easter Recess.—The House of Commons was adjourned until Monday, April 4th.

The annual meeting of subscribers of the Cremation Society of England will be held at the new address of the offices of the society, 52, New Cavendish Street, W., on Wednesday, April 13th, at 3 p.m., to consider the annual report of the Council and elect office-bearers for the ensuing year. The valuable work of the Cremation Society was noted in our issue of February 12th. Among the distinguished personages reported by the Council to have been cremated during the past year were Sir William Osler, Sir Robert Morant, Dr. Cecil Lyster, Sir Henry Burdett, Sir Charles Matthews, Admiral Lord Fisher, and Lord Glenconner.

England and Wales.

A SURVEY OF SURGERY.

IN an address to the students of the Leeds Medical School, on March 15th, Sir Berkeley Moynihan sketched the romance of the art of surgery from 2000 B.C. down to the present day. There was evidence, he pointed out, that such operations as circumcision and trepanning were practised more than two thousand years before Christ. Beyond these, however, nothing of any consequence was done surgically until the time of Hippocrates, who was born 460 B.C. After Hippocrates there was a big gap before any other notable figure appeared, and then there was Celsus, a dilettante patrician, who probably therefore did not practise medicine, but was merely a recorder of the work of others. Galen was the next great figure, and for nearly 1,500 years after him practically no progress was made. Then came the period of the anatomists; the real father of anatomy in modern times was Mondino, who lectured in Padua in 1315. Then there was Sylvius who inspired Andreas Vesalius, the greatest anatomist of all time. Another big gap in the progress of surgery followed, because nobody knew anything about pathology. The man who laid the foundation of modern surgery, himself the greatest of surgeons, was "that cantankerous, red-headed little Scotchman" John Hunter. He and Morgagni built the solid foundation of pathology on which the modern edifice of British surgery had been erected. But the world waited for something to make surgery safe, and it came with Pasteur. The revolution that had been wrought in modern surgery was due to Lord Lister, and to him alone. Lister had saved more lives than all the wars of all the ages had thrown away. All the modern operations owed their existence to the work which Lister did. There had been greater surgeons during the last thirty years than in all the centuries which preceded that period, and that was all due to Lister. In conclusion, Sir Berkeley Moynihan said that to-day the view prevailed that surgery had reached her destiny, and was now almost a finished art. He believed it was true. He did not believe that the mortality percentage would ever be much smaller than it now was, but he regarded that not as an end, but as a beginning. The surgery of to-day must not be considered as bearing only upon the art of surgery; it was an art which allowed for the discovery of the reasons why, in the whole science of medicine. They could look on it now as the key which had been made to unlock a great many closed doors. It was only just beginning its true function.

LEEDS UNIVERSITY.

The University Council has appointed Mr. R. J. Stewart McDowall, M.B., Ch.B., Edin., to the post of lecturer in experimental physiology and experimental pharmacology. During the war Mr. McDowall served overseas with the R.A.M.C. for nearly four years, of which two and a half were spent in the Sinai desert. Since demobilization he has been working under Sir E. Sharpey Schafer in the Physiology Department of the University of Edinburgh, and is lecturer in that department and clinical tutor in medicine at the Edinburgh Royal Infirmary.

FAREWELL DINNER TO DR. ALEXANDER STOOKES.

A representative gathering of Liverpool obstetricians and gynaecologists, with Professor Henry Briggs in the chair, entertained as their guest Dr. Alexander Stookes at dinner at the University Club on March 19th, on the eve of his departure from Liverpool to reside in Devonshire. Under the age limit Dr. Stookes has this year retired from active public professional service, which began in 1895 at the Maternity Hospital and in 1899 at the Samaritan Hospital for Women. In both hospitals as a surgeon he has done admirable work. After dinner appreciative references to Dr. Stookes and his work were made by Mr. Adam G. Rankine, Dr. T. R. Bradshaw, Dr. Glyn Whittle, Professor Wilberforce, Dr. Frances Ivens, Mr. T. H. Bickerton, Dr. Blair Bell, and others. The Chairman, on behalf of those present and of friends in Manchester, Leeds, and Sheffield, who subscribed to the gift, presented Dr. Alexander Stookes with a cheque. Dr. Stookes, in expressing his grateful thanks, spoke with confidence of the

younger generation, whose advancement should be assisted by the retirement of the seniors in due season. He had passed through many happy days in Liverpool, and he looked forward to many more in Devonshire. It was a source of delight to know that he took with him the good wishes of so many friends. At the close of the happy evening Miss Ivens proposed the health of the Chairman. The secretarial duties of the dinner were ably carried out by Dr. Norman B. Capon.

INSTITUTIONAL TREATMENT OF TUBERCULOSIS.

The Public Health Committee submitted to the last meeting of the London County Council a report on the treatment of tuberculosis in London, particularly with regard to the method of selection of patients for institutional treatment, the grading of the institutional accommodation available, and after-care. It has been found desirable that all patients recommended for institutional treatment, whether insured or uninsured, should if possible first pass through a period of observation in hospital beds, and the reservation of 250 such beds at the Brompton Hospital and of 75 at the City of London Chest Hospital has been arranged. The patients occupying these beds will be watched by the tuberculosis officers of the staff of the county medical officer. The average duration of stay in the observation beds will be from two to four weeks. The value of the observation bed is stated to have been confirmed by an observation of 158 cases sent for diagnostic purposes during 1920 to the hospitals just named. Of this number, 124 (78 per cent.) were reported as not suffering from tuberculosis, and of the 34 cases diagnosed as tuberculosis 10 were considered to be arrested cases not requiring active treatment. The total provision of institutional accommodation, including these observation beds, is for 2,550 beds—1,800 for adults and 750 for children. The 1,800 adult beds are graded into observation and emergency beds, beds for early cases, for moderately advanced cases, for far-advanced cases, for surgical cases and for training. The number of beds for early cases (300) is reduced in conformity with the stricter definition proposed by the Ministry of Health of what should be regarded as a true sanatorium case; the moderately advanced cases (500 beds) are selected patients who have been found by careful observation to be likely to gain material benefit from institutional treatment; the provision for far-advanced cases (400 beds) is subject to alterations made by boards of guardians and the Metropolitan Asylums Board; the 100 training beds are at farm colonies and similar institutions, and are provided only for ex-service patients. The estimated expenditure on the tuberculosis service for 1920-21 is £632,970, of which rather more than one-third is borne by the rates. Representations are to be made to the Ministry of Health as to the desirability of instituting an inquiry into the steps which should be taken to provide suitable employment for tuberculous members of urban populations, and as to the importance of an early decision upon the constitution and functions of care committees. It may be noted that the Greenwich Borough Council proposes to establish, under the medical supervision of the tuberculosis officer of the local dispensary, a centre for the training and employment of tuberculous patients in suitable occupations.

SOUTH-WESTERN OPHTHALMOLOGICAL SOCIETY.

A meeting of the South-Western Ophthalmological Society took place at Bristol on March 9th, and was fairly well attended. In spite of the large area covered by the society members were present from Plymouth, Newport, Weston-super-Mare, and other districts. Cases were shown at the Bristol Eye Hospital in the morning, and after lunch Mr. R. J. Coulter opened a very interesting and rather heterodox discussion on "Some squint problems." He made a demand for a simpler operation than is at present customary. The honorary secretary of the society is Mr. E. H. E. Staek of Bristol.

VENEREAL CLINICS ARRANGEMENTS FOR LONDON.

At the meeting of the London County Council preceding the Easter recess sanction was given to a renewal of the arrangements for the diagnosis and treatment of venereal diseases in London. For the last four years the Council has joined with certain neighbouring county and county

borough councils for the common utilization of the facilities afforded by a number of the London hospitals. The scheme has been found to work well, but the Council now desires to make modifications in it without the delay incurred in obtaining the consent of all the participating authorities. During the past year the number of patients' attendances has been 430,000, a considerable increase on previous figures. A venereal clinic has been opened at the Royal London Ophthalmic Hospital, the first to be established at an ophthalmic hospital in London. The estimated expenditure of the Council and all the participating authorities for the coming year is £126,583, of which three-fourths are met by Government grant. No increase is proposed in the amounts—£3,500 and £5,000 respectively—allocated for publicity arrangements and for drugs. A joint inspection of the clinics has recently been undertaken by Dr. F. N. K. Menzies and Brevet-Colonel L. W. Harrison, and a report is to be made to the Council at an early date on the extension of the facilities and increase of efficiency of the clinics.

Scotland.

TUBERCULOSIS SCHEMES IN EDINBURGH.

At a meeting of the Edinburgh Town Council last week a long discussion took place on a recommendation of the Public Health Committee to terminate the arrangement as to consultations with Sir Robert Philip and Dr. James in connexion with the city's tuberculosis scheme. A letter was read from the secretary of the university protesting against any undue haste in deciding a matter which might affect the interests of the university. It appears that the agreement made in 1914 provided that, in the event of the university establishing a chair of tuberculosis, the city corporation would give all reasonable facilities for teaching in connexion with the work carried on in the corporation's hospital, dispensary, and farm colony, and for the purpose of research. The university did establish a chair of tuberculosis and Sir Robert Philip was appointed professor. The Public Health Committee would appear to have been moved to terminate the agreement with Sir Robert Philip to act as consulting officer by the fact that experience showed that the occasions for making use of his services were few or none. A letter was also received from the Royal Victoria Hospital Trust asking that more time might be allowed for consideration, and this view was supported by the Lord Provost. Eventually, however, the recommendation of the Public Health Committee was adopted by 22 votes to 14. As the matter stands at present it would seem that the corporation and the Edinburgh Insurance Committee, which contributed to the cost, will cease to have the advantage of the services of Sir Robert Philip and Dr. James as consulting experts, but that the professor of tuberculosis in the university will continue to enjoy facilities for teaching and research at the institutions maintained by the corporation for tuberculosis.

MEAT INSPECTION IN SCOTLAND.

A report by Lieut.-Colonel Leighton, Medical Officer (Foods) Scottish Board of Health, on the subject of a uniform system and standard of meat inspection in Scotland has been now issued.¹ This report (which also embodies the reports of three committees of experts appointed by the board to assist Colonel Leighton in his inquiry) is of importance to public health officials and others interested in the subject of meat inspection and its bearing upon the health of the people. A survey is made of the conditions obtaining throughout Scotland in connexion with the administration of slaughterhouses and the inspection of carcasses, and these conditions are subjected to critical examination. The reports of the three committees deal respectively with (a) problems of general administration, (b) difficulties peculiar to rural areas, and (c) proposals calculated to secure uniformity in methods of inspection and in standards of judgement. The latter contains a complete scheme of instructions to meat inspectors as to the method of procedure to be followed in the examination

of carcasses and the standards to be observed in the passing or condemnation of the meat. This is the first scheme of the kind that has been drawn up and published in the United Kingdom.

POST-GRADUATE MEDICAL TEACHING IN GLASGOW.

For many years post-graduate instruction in medicine has been given in several of the hospitals in Glasgow, but it was only in the early part of 1914 that a special endeavour was made to bring together all the institutions and hospitals for the purpose of organizing a permanent comprehensive scheme of post-graduate teaching for Glasgow as a whole. Owing to the intervention of the war little progress was made until 1919, when an emergency post-graduate course was organized and carried on in the summer and autumn. The course was highly successful and the committee in charge felt justified in recommending that a permanent scheme should be instituted. Such a scheme was adopted on March 2nd, 1920, at a joint meeting of the Faculty of Medicine of the University of Glasgow and the General Committee for Post-Graduate Medical Teaching which had been appointed in 1914. The various teaching institutions and teachers taking part in the scheme constitute an association the business of which is managed by a board elected periodically by them. The chairman of the board is Principal Sir Donald MacAlister, K.C.B., M.D., and the vice-chairman Sir Hector C. Cameron, C.B.E., M.D. To inaugurate the scheme the board arranged a series of weekly demonstrations for practitioners extending from November last till May of this year; the number of practitioners taking advantage of the series is satisfactory. For the ensuing summer and autumn the board has arranged a comprehensive course of instruction for medical practitioners extending from May till October. Most of the hospitals in Glasgow are taking part in it, and the classes as far as possible have been arranged so that a practitioner, if he so desires, may occupy the greater part of each day in attending classes. The classes are open to all qualified medical practitioners, and will be conducted independently of the undergraduate courses. A practitioner may enrol for one or several classes, and may attend for one or more months as desired. These classes have been specially designed to meet the needs of general practitioners, but the board has also had in view the provision of facilities for young graduates and others who may wish to obtain a closer acquaintance with hospital work in one or other of its branches and who are prepared to give the necessary time. Arrangements have been made whereby a limited number may become attached to wards or out-patient departments as clinical assistants for definite periods in children's diseases, mental diseases, tuberculosis, or venereal diseases. They would work under the direct supervision of the physician or surgeon in charge and carry out such detailed investigations as directed. It has long been felt that Glasgow, in the midst of such a vast industrial population, with its abundance of clinical opportunities, should become one of the leading centres of post-graduate medical teaching. The Board of the Glasgow Post-Graduate Medical Association presents to the medical profession this year its first organized scheme of teaching. Syllabuses giving full information concerning the classes and clinical assistantships may be had on written application to Dr. A. M. Kennedy, Secretary, Post-Graduate Medical Association, University, Glasgow, or by applying personally at the various hospitals which are taking part in the scheme.

GLASGOW CANCER HOSPITAL.

At the annual general meeting of the Glasgow Royal Cancer Hospital on March 23rd, Sir George T. Beatson, senior surgeon to the hospital, presided. After referring to the decision of the directors to reopen the chemical branch of the research department, which was closed during the war, and pointing out that the funds of the research department were kept separate, he strongly appealed to the public for financial support. Like other voluntary hospitals, they had suffered from the stress of war conditions. The annual report stated that during the year the directors had seen their way to reopen the research department on a working basis again, but the work to be carried on would be confined to the chemical department of research. In

¹ To be obtained direct from H.M. Stationery Office, 25, Firth Street, Edinburgh, or through any bookseller, price 4s.

connexion with the biochemistry of cancer, they had appointed Mr. A. N. Currie to carry on certain investigations. At present this was the only branch of research that funds allowed of restarting, but it was a very important department. Of the 128 cases treated in 1920, 57 were males and 71 females. During 1920 there were 66 deaths in the hospital—31 males and 35 females. The majority of the 128 cases were inoperable, but for some of them surgical operative measures were possible and of a hopeful nature. In the treatment of the inoperable group radiation had been the procedure mainly relied on, and this had been carried out by α rays rather than by those of radium, whose field of application was being more narrowed down as experience was gained in its use. The hospital was indebted to the West of Scotland Radium Committee for a supply of radium emanations for treatment.

MATERNITY AND CHILD WELFARE.

At the annual meeting of the Lauriston Home for Maternity Rescue Work, Edinburgh, held on March 15th, the annual report was presented by Dr. J. Haig Ferguson. Sheriff Crole, K.C., who took the chair after discussing the need for such a home, remarked that the Carnegie Trustees had some time ago offered to establish a centre for child welfare and maternity work. Nothing had yet been done, but the offer was still open, and some of those who were interested in the matter were prepared to formulate a scheme for submission to the trustees. In giving an outline of the proposals, the chairman said that the Lauriston Home would form an integral part of the scheme, and he suggested that something might be done under the joint auspices of the University of Edinburgh, the Town Council, the Royal Infirmary, and the Royal Maternity Hospital. A better maternity hospital was needed, and the present building might be made use of in connexion with the proposed child welfare scheme.

Correspondence.

THE MINISTRY OF HEALTH MEMORANDUM ON ENCEPHALITIS LETHARGICA.

SIR,—I fear that a slip in proof reading, for which I accept responsibility, led to the date 1658 appearing in this memorandum with its last two figures transposed, and also to the name of Ozanam being printed as Ozanann. I should be glad for space to thank Dr. F. G. Crookshank for both corrections and for his historical notes.

Dr. Crookshank's other criticisms of the memorandum are governed by his opinion of the stress which should be laid on the association of encephalitis lethargica with influenza. In objecting to the statement that "no direct relation has been established" between these two diseases, he seems, however, to read more into the words quoted than the ordinary reader would be disposed to do. Typhus and relapsing fever—to take an instance where the facts are much better known and proved—are both spread by the same agency of infection, while epidemics of the one are often most closely associated, both in time and in locality affected, with epidemics of the other. This does not, however, make it incorrect to say that no direct relation exists between typhus and relapsing fever; they are distinct pathological processes, and either disease can occur independently as an epidemic.—I am, etc.,

Whitehall, S.W., March 26th.

G. S. BUCHANAN.

SIR,—It appears, on further inquiry, that the paragraph of the Ministry of Health's recent memorandum lately criticized by me in your columns (March 26th, p. 478) is really the *imago* of a paragraph to be found in Dr. Bassoe's paper on "Epidemic encephalitis," printed in the *Journal of the American Medical Association* for April 5th, 1919.

Dr. Bassoe, who makes no claim to historical authority, derived his information from an intermediate source, and selected his references, not so much with a view to proving the anterior occurrence of encephalitis lethargica, as to showing the epidemiological relation between prevalences of encephalitis and of influenza.

It is therefore the more surprising that the Ministry, while copying Dr. Bassoe's paragraph and adopting literal

inaccuracies therein, should have added the grossly incorrect allusion to Willis and suppressed Dr. Bassoe's pointed and valuable references to "grip" and "fièvre catarrhale."

Had these references been not suppressed, the paragraph would have been far less exposed to criticism. But then the tenure of the official attitude concerning influenza and epidemic encephalomyelitis would have required no little dexterity.

It is, I think, in the true interests of epidemiological research that attention should be drawn to the manner in which this recent memorandum of the Ministry has been prepared, for much in it is open to substantial criticism besides the points to which I have alluded.—I am, etc.,

London, W., March 23rd.

F. G. CROOKSHANK.

ACIDOSIS AND ALKALOSIS.

SIR,—Dr. J. S. Haldane's review on the physiology of respiration, renal secretion, and circulation is of great interest; but I do not think he quite does justice to many workers in this field when he charges them with "failing to interpret rightly a diminution in the so-called 'alkaline reserve' of the blood," and, further, states that they had quite wrongly identified diminution in "alkaline reserve" with acidosis. No worker, so far as I know, has really confused the alkaline reserve of the blood with its hydrogen ion concentration. The confusion, if such exists, is purely a question of terminology.

Naunyn introduced the term "acidosis" for the formation in metabolism of large amounts of non-oxidizable organic acids (I quote from Magnus Levy's article in Von Noorden, *Path. des Stoffwechsels*, 1906, i, p. 189). Oxybutyric acid formed the most notable example, but the excretion of lactic acid in diseases of the liver was considered one of several other examples. In this use of the word there was no suggestion that oxybutyric acid necessarily acted by making the blood acid; in fact, controversy raged for many years as to whether cema was produced in this way, or whether the acids were poisonous in themselves. It is fairly certain now that the latter is the correct alternative, aceto-acetic acid being the poisonous substance.

Barcroft was, I think, the first to give a more precise meaning to the term acidosis, being one of the earliest, if not the first worker, to investigate physiological conditions where it was necessary to draw a distinction between the alkaline reserve of the blood and its hydrogen ion concentration. He states (*Respiratory Function of the Blood*, 1914, p. 227):

Here let me explain my use of the word "acidosis" in reference to the blood. In the following pages it will signify the appearance of acids (exclusive of CO_2) abnormal in kind or perhaps only in quantity in the blood, or even a decrease in the bases present. By acidosis, then, I mean an increase of acid relative to basic radicals in the blood, CO_2 not being considered. By the term acidosis I will signify nothing concerning the final reaction of the blood, which is largely regulated by the amount of CO_2 present.

This was a natural extension of the meaning of a word which had been in general use for years previously. This definition was quoted in full and accepted by Hasselbalch (1916) and by Peabody in America in an early review of the subject, and it has been generally adopted up to the present time. The more explanatory, but at the same time more cumbersome, phrase, "diminished alkaline reserve," was introduced by Van Slyke and Cullen in 1917.

Recently, Dr. J. S. Haldane and Professor Benjamin Moore have used acidosis as signifying increased hydrogen ion concentration, and alkalosis as diminished hydrogen ion concentration of the blood.

Such a variation in the definition of a term is of no importance to a man working at the subject, as he soon realizes in which particular sense an author is using it; but it is very confusing to others, and it was in the hope of simplifying the position that, at the last meeting of the Physiological and Pharmacological Section of the British Medical Association at Cambridge, the suggestion was made, and was favourably received, that increased and diminished hydrogen ion concentration should be known as "acidaemia" and "alkalaemia" respectively, and that diminished and increased alkaline reserve should be known as "acidosis" and "alkalosis."

The point I would urge is that the actual nomenclature is of no importance, but let us all use the same one. If we

use "acidosis" and "alkalosis" in Dr. Haldane's sense, can be supply us with a short expression for "diminished alkaline reserve"? It would be as well if some authoritative body gave us a lead. I am sure we should all be prepared to follow it.—I am, etc.,

Woldingham, Surrey, March 19th,

E. P. POUTON.

GLANDULAR FEVER.

Sir,—Drs. Lethby Tidy and Morley are to be congratulated on the timely appearance of their article on this disease. I think it will be found to appeal to a large number of practitioners in this district (West Riding), and possibly in many other places, by enabling them to label definitely what I think has been a large—possibly very large—number of examples of the disease.

In consulting practice naturally one does not see many of these cases, but I have been interested in them for the past two years, during which period I have seen at least a dozen, mostly the children of doctors or cases in which, from the characteristic debility and tardiness of convalescence, the slow involution of the (often considerable) glandular enlargement, and the marked tendency to relapse, the question of tuberculous adenitis has been raised. But I have made a point of comparing notes with a large number of practitioners, from which I derive the impression, amounting to a practical certainty, that we have had in the towns of this district not inconsiderable epidemics of the disease. I hope very much that some of those who have had this experience will send a brief note to the JOURNAL, for only in this way can we get a really complete view of the disease. General practitioners are as a rule too busy to make many contributions to medical literature (to our great loss), but I shall be very much surprised if many do not confirm what I have stated, and say that an "unusual epidemic of sore throat with tedious and considerable glandular enlargement" has been a recent feature of their practice.

I am personally satisfied that the disease is one *sui generis*, and, in typical cases, presents no difficulty in diagnosis. I should be inclined to emphasize the frequency of some complaint of "sore throat," referred either to tonsils or pharynx, but in which the loca changes, as revealed by inspection, are slight. The proportional affection of adults is also another interesting point.—I am, etc.,

Leeds, March 26th.

W. H. MAXWELL TELLING.

Sir,—I was very interested to read in the JOURNAL of March 26th the article on glandular fever by Drs. Tidy and Morley. The authors state that there is some reason to believe that a considerable number of cases are occurring at the present time, so it may be of interest to state that recently (from mid-February to mid-March) I have seen in this district nine cases of this nature. All of these patients were between the ages of 4 and 13 years; seven were in separate houses (most of them were isolated at once), and the remaining two were in the same house, one of these occurring six days after the first. I heard later that the mother in this house was ill nine days after the commencement of the first child's illness, and was in bed for two days with feverishness and swellings behind her ears. Seven of the cases were mild and the remaining two severe; one of the latter was complicated by nephritis, and there was definite oedema of ankles (Drs. Tidy and Morley state that there is no previous record of the occurrence of oedema). In this case all signs of nephritis had disappeared twenty-five days after the onset of the disease. The glands affected were the cervical beneath the sterno-mastoid muscles, and I found no other glandular enlargement. In eight of the nine cases the enlargement was bilateral; the glandular swelling was generally rather larger than a walnut, and there was comparatively slight tenderness. In every case the throat appeared normal. In one case a slight macular eruption appeared on the trunk on the sixth day; it caused some irritation and lasted two days. The temperature in no case exceeded 103° F.—I am, etc.,

R. D. AYLWARD, M.R.C.S.

Tunbridge Wells, March 26th.

X-RAY RADIATIONS AND CANCER.

Sir,—X-rays and radium are undoubtedly powerful therapeutic agents, but at present we fail to make full use of them, owing to the fact that we are as yet not masters of the technique necessary to get their full beneficial effect. Consequently most of our failures may be said to be due not so much to the fault of the agent as to the fault of the technique.

Our results are bound to be erratic until we know what are the conditions and dose necessary to produce a lethal effect on pathological cells, and at present they are to a great extent dependent on luck—that is, whether the particular dose administered happens to be the most effective one; and, secondly, on the practical experience of the radiologist himself. It ought to be possible not only to administer x-ray radiations with the same degree of accuracy as drugs, but to have some idea as to what prescription is required for the case in hand.

Dr. Reginald Morton has recently described a Continental method for deep therapy, and I have lately heard of yet another. Many of us can recall similar reports which before the war periodically found their way to this country from the same source, each in turn giving way to some newer idea. Consequently radiologists have become cautious about accepting without careful investigations these methods of "mushroom" growth. We must know on what foundation they are based—for instance, there is nothing to be gained by inventing ingenious apparatus for the production of large quantities of very penetrating rays unless we have some sound reason for thinking that this is the type of ray required.

Radiologists are divided into two schools—one striving for full cell absorption and the other for extreme penetration. The second class are endeavouring to obtain x rays as penetrating as radium, but I have yet to be persuaded that radium is of a greater therapeutic value than x rays properly applied, except, of course, in inaccessible positions; and I suggest the possibility that the therapeutic effect of radium may be due to something besides penetration. If we set out to produce skin reaction we use a medium or low type of ray without a filter, as this gives the greatest skin absorption in the shortest time. It is possible to get the reaction, however, even if we use a high-penetrating type of ray through a thick filter, but the exposure will be unnecessarily prolonged and nothing will be gained.

The same argument may be logically applied to deep-seated tissues—that to get our effect full cell absorption is necessary, and that by over-filtration we probably cut out the very rays that would have been absorbed by the pathological cells, and although to a certain extent this can be made up by prolonged exposure, the net result is the same. Until physicists alter their dictum that "x rays have no effect upon the medium unless absorbed by the medium," and this is backed up by the effect on the skin, it is wiser, I think, to work on the cell-absorption basis.

A large percentage of the cases of mammary carcinoma that pass through the x-ray department of the London Hospital die from metastases in the thorax or elsewhere in the body, while subcutaneous recurrences are controlled.

I have devised the duplex method of treatment installed in temporary quarters at the London Hospital with the idea of controlling general metastases in the same way as the more superficial. Any method devised for this purpose must fulfil two conditions: (1) It must be possible to administer a lethal dose to the pathological cells lying at various depths and in un'own positions; (2) the irradiated area must be large.

The duplex method consists of two separate installations—one operating a tube in front and the other a tube at the back of the patient, both running at the same time. After the first full dose has been given, the direction is changed so that the radiation is now from side to side, the arms being forward and raised. In this way the deepest parts of the body are subjected to radiations from four points of the compass, and the resulting cell absorption must be much greater than with our present method. A large radiation field is used, including practically the whole trunk, this being attained by using the standard lead glass shield reversed. The duplex method, therefore, may be described as an elaborated method of cross-firing, differing, however, in two essentials from our present idea: (1) Both tubes are working at the same time from both sides of the body; (2) a very large area is covered.

These are the bare outlines of the method, which may be of value to those working on the absorption basis. From the statements made by some writers on the harmful effects of large doses of x rays, one may expect certain phenomena which are at present being watched for, but I feel certain that these can be avoided as long as the treatment is kept within certain limits, for I believe it is possible to give an overdose to the deeper structures in the same way as we can to the skin.—I am, etc.,

London, W., March 22nd.

S. GILBERT SCOTT.

SIR,—If, in my letter published a fortnight ago, I gave the impression that my technique in pre- and post-operative x ray treatment was originally based upon the results of animal experiments, I did not intend to do so. The method rests upon the clinical experience of ten years—an experience, I hasten to admit, more largely concerned with breast cancer than with any other, although I have also treated a considerable number of cases of malignant disease of the uterus. What I meant to imply was that the experiments at the Rockefeller Institute, and those made by Professor Russ in this country, furnished an explanation for the success of a dosage which is certainly insufficient to "kill" a growth by direct action upon the cells.

I have been familiar with the laboratory results referred to only for about three years, and I have not in any way altered my technique because of them. They are, however, of great interest to me as tending to confirm views which I had formed as a result of clinical observation. But it is not too much to hope that in the future the laboratory may enable us, by repeated examination of the blood, to graduate our x -ray dosage according to the response on the part of the patient.

Dr. Finzi says he has seen a few cases in which small doses apparently stimulated a growth; I have seen a few cases in which very large doses apparently produced a catastrophe—that is, there was a *post hoc* relation.

I have been careful not to apply opprobrious terms to the Erlangen method, for I have found it a good rule to believe that whenever an earnest and intelligent body of men consistently advocate a particular method, there is something, and usually a good deal, in it. I have also learnt not to condemn a drug or therapeutic procedure solely because the theory on which its use was based, or by which its action has been customarily explained, is eventually shown to be false. I commend these rules to Dr. Finzi.

With regard to British apparatus, the 24 in. coil has been long available, and I have myself, as an experiment, run x -ray tubes in an oil bath up to a 16 in. equivalent gap.

As is very often the case in controversies, the two schools are not nearly so far apart as might at first sight appear. Thanks in no small degree to the pioneer work of Dr. Finzi ten years and more ago, every one admits now that a tube with an equivalent spark gap of between 10 and 12 inches is desirable. Owing to lack of standardization of spark gap terminals, exact comparison is not easy. A 16-inch gap may be even better, but this does not necessarily follow, any more than it follows that increasing frequency of sound vibrations will indefinitely cause greater shrillness of note; a point comes when the effect on the ear begins to diminish. It may even be, as Knox has suggested, that each particular tumour has its own "note."

Then, as to dosage, we are all agreed that x rays must not be administered consecutively for long periods. When two or three large doses are given, the total period occupied may be nearly as long as when twelve or fifteen smaller doses are administered. The difference is thus narrowed down until it is, in practice, chiefly a question as to how to divide up a certain total of x -ray energy. About two years ago Professor Russ recorded a case of multiple carcinomata of the skin in which some of the nodules were subjected to single large doses; others to the same dose in fractions spread over several days. In each case the nodules disappeared, but in the former case with much, at any rate temporary, injury to the skin; in the latter with no such disturbance. Now, on the face of it, the divided dose seems the better here, but only a study of results over many years can in reality settle such a question. If, however, in the above instance, one had decided to cut out

the nodules surgically, I think there can be no doubt as to the advantage of the divided dose for pre- and post-operative treatment.

One has to remember that when a patient is operated on for cancer he has a surgical risk to face; and he may be cured whether any x -ray treatment is given or not. The big dose method is admittedly dangerous. If it is used as an alternative to surgery its risks may legitimately be faced; but why should we submit to fresh dangers a patient who has successfully come through an operation? Only the most positive proof that the divided dose is useless as well as harmless could lead us to abandon it, whereas a vast body of clinical and experimental evidence points to its value.

With theoretical considerations we need not concern ourselves overmuch. The advocates of the divided dose have never denied the value of x rays as destructive agents in localized cancer masses; but they claim that, even locally, the response of surrounding healthy tissues has as much to do with a good result as direct depression of malignant cells. That an excessive local dose may render the patient an easy victim to distant metastasis is now only too certain, but this danger has been recognized only comparatively recently, together with the fact that, by suitable dosage, the body resistance may be improved. The interaction of constitutional and local factors is so complex that it is doubtful if any conceivable technique can secure, coincidentally, the maximum help from each. In practice we shall obviously stress the one or the other, according as we have our attention specially directed to the main growth or to possible metastases.

Mr. Cecil Rowntree's reference to x -ray cancer in man needs a word of comment. Such cancer was produced by years of daily exposure to unfiltered rays, generally very soft. This is a very different matter from the use of hard filtered rays in courses which never extend over two months at a time, and are not repeated until an interval of three to six months has elapsed.

Mr. Childe is against delaying operation for a single day; but this is surely an *ipse dixit* on his part—a thing which he depreciates in the radiologist. Whatever differences as to details may split the x -ray camp, he will find it now universally agreed that pre-operative radiation is desirable. The reason is obvious. The surgeon cannot guarantee that no cancer cells will be disseminated by the knife. If, therefore, any method is known by which either the cells of the primary mass can be made less active, or the tissues as a whole more resistant, or (better still) both of these desirable ends be accomplished, surely it should be used.—I am, etc.,

London, W., March 18th.

F. HERNAMAN-JOHNSON.

TUBERCULOSIS MORTALITY.

SIR,—We are still very much in the dark about the relation of health and disease to wages and prices; but all who value impartial inquiry, honest interpretation, and clear statement are in the debt of the author of the chart published by the *Times* on January 1st, 1921. Thanks to him, the main outline of the facts can be bought for a few pence. The information given in the chart that is relative to the problem set by variations in the rate of mortality from tuberculosis may be summarized thus:

1. From about 1857 to 1900 real wages in this country nearly exactly doubled. Total incomes from profit of various kinds increased during that period nearly as far and as fast. The rise in wages was due in part to nominal additions to their rate, but a nearly steady fall in prices kept raising real wages faster than nominal wages. That fall in prices stopped in 1895, but rises in nominal wages rather more than kept step with the rise in prices from 1895 to 1900. During that period (1857-1895) mortality from tuberculosis diminished, as we all know, steadily and rapidly.

2. From 1900 to 1914 nominal wages kept rising, but prices rose faster. Real wages accordingly fell and were, by 1914, about 10 per cent. under 1900. As we all know, the mortality from tuberculosis diminished more slowly during that period than while real wages were rising.

3. During the first three years of war prices rose far faster than wages, so that in 1917 the average wage-earner was no better off than in 1870. During that period the mortality from tuberculosis at first tended to rise, and then actually rose.

4. From 1917 to 1920 nominal wages rose faster than prices until, in mid-1920, real wages had risen nearly to the level of 1900. They were then, in fact, exactly as high, when measured in terms of commodities, as they had been in the years 1896-7-8. And, as we know, tuberculosis mortality is falling once more.

These facts come from an impartial source and are no doubt accurate. But we sorely need a fuller and more detailed statement. Will not Dr. Brownlee give us data, published in the JOURNAL, to show us what relation, if any, exists between consumption of food and consumption of alcohol in the country and mortality from tuberculosis? Is it possible to work out the average consumption of fats during the critical years?

Such data would be of the greatest value in other connexions. If, as the figures quoted above suggest, the wage earners as a class have been worse off during the past ten years than a generation ago, it is surely both unjust and unwise to encourage them to contribute largely to hospitals. During the period 1900-20 incomes from profits rose steadily irrespective of movements of prices. Profits and wages, which kept step while prices were falling, parted company so soon as prices began to rise. Both doubled in the earlier period. Profits alone increased in the later period. Surely it is to their owners rather than to wage earners that those who support the voluntary principle for the upkeep of hospitals should look for what larger expenditure the rise in prices has rendered necessary.—I am, etc.,

Brailsford, near Derby, March 21st.

NORMAN LEYS.

IRRITABLE BLADDER.

SIR,—I have read with interest Dr. Hamilton's letter in your issue of March 26th on this subject. Such cases very frequently present themselves for treatment in Bath, and are cleared up by a course of drinking the mineral water.

If he will have a quantitative analysis made he will find that in all cases there is an abnormal amount of uric acid in the urine, and that frequently the specific gravity is low. I have come to regard such cases as due to the irritation caused by the excess of uric acid in crystalline form.

Speaking from twenty years' specializing in spa practice in Bath, I agree with him that both sexes suffer equally. I find in the urine of such patients anywhere from 0.5 to 1 grain per ounce of uric acid, and when cure has resulted the uric acid and the specific gravity have gone back to the normal. Sharp attacks of haemorrhage have also not infrequently been reported in the histories.—I am, etc.,

Bath, March 27th.

CHAS. BEGG, M.B., C.M.Edin.

ASTHMA AND ANAPHYLAXIS.

SIR,—Mr. Frank Coke's important and interesting paper on asthma and anaphylaxis suggests new lines of thought in this direction.

For some years the relationship of asthma to tuberculosis has interested me, and I had concluded on clinical grounds that tuberculosis may be in some cases the cause and in others the effect of asthma. In other words, asthma may predispose to tuberculosis by causing a local lowering of resistance; or, on the other hand, the onset of pulmonary tuberculosis may give rise to asthma in patients with an asthmatic diathesis.

This might account for some of the 50 per cent. of cases which he finds do not react to other proteins. Conceivably the exciting agent in the tubercle bacillus may be some portion of it other than tuberculin. No doubt Mr. Coke could devise a means of testing this.—I am, etc.,

Paignton, Devon, March 23rd.

E. WARD.

SIR,—In the interesting account given by Mr. Frank Coke, F.R.C.S., in the BRITISH MEDICAL JOURNAL of March 12th, a very vivid and striking picture is given of anaphylaxis.

I have used serums in the same persons in such a way that I think anaphylaxis might have occurred, and yet nothing but good has happened. And I venture to ask if anaphylaxis has ever been known to occur when serums are given by the mouth.

All the records of anaphylaxis seem to have followed the injection of serums; and if it could be proved experimentally that serum when given by the mouth implies immunity from the tragic syndrome of anaphylaxis, it would be a boon of the highest order.

Personally, I have never injected a case of diphtheria, but always for thirty years have given the antidote by the mouth, and its strikingly beneficial results, without any

of the drawbacks of injection, have been very gratifying. From 2,000 to 6,000 units can easily be given in a little chloroform water. And if this method confers immunity from anaphylaxis, it should, I think, be universally adopted in preference to injection.—I am, etc.,

Newcastle-upon-Tyne, March 20th.

T. M. ALLISON, M.D.

SAPRAEMIC GLYCOSURIA.

SIR,—It has been known for many years that reducing substances are apt to appear in the urine in toxic conditions and various infectious diseases. As far back as 1878 Prevost, in a treatise on intermittent glycosuria, laid particular stress on its association with suppuration, and subsequently Redard and others have emphasized the connexion. In none of the cases so far published, however, has the exact nature of the reducing substance been established, and unfortunately this point has also been overlooked by recent contributors to your columns.

My own experience has been that glycuronic acid, pseudo-laevulose, and more rarely true laevulose and pentose, either alone or with dextrose, occur more commonly in toxic conditions than pure dextrosuria. When the latter has been met with, examinations of the blood after a test meal have shown that the patient's carbohydrate tolerance was lowered, and that, although some improvement might take place under treatment, complete recovery did not occur. It seems probable, therefore, that there are two conditions, one a "pseudo-glycosuria," from which the patient completely recovers; and the other a true, or mixed, glycosuria, which improves when the source of the toxæmia is removed, but leaves the patient at least a potential diabetic.

Whether the lowered carbohydrate tolerance in the latter is antecedent to, and a predisposing cause of, the infection, or is entirely an after-effect, is a matter of opinion, but personally I am inclined to think it is the primary condition in all cases where dextrose is excreted. My chief reason for saying so is that I have never yet met with a case of furunculosis where the blood sugar was not abnormally high, in spite of the fact that in some there was no sugar in the urine and glycosuria never developed. A short time ago, for example, I saw a patient in consultation who had a large boil on his back and had been operated on for another on the buttock a few weeks previously. Although his urine gave no reaction for sugar, examination of his blood showed 0.24 per cent. three hours after a test meal, compared with 0.16 per cent. to 0.17 per cent. in a normal person.

With regard to the disappearance of sugar from the urine after the removal of a septic focus, it must be borne in mind that, just as a high blood sugar does not necessarily result in glycosuria, so the disappearance of sugar from the urine may be due to other causes than improved carbohydrate metabolism. The pseudo-glycosurias are no doubt part of a protective mechanism, and probably arise from defects in the functions of the liver consequent on the toxæmia, so that one would expect them to clear up when the source of the toxin is removed. A true dextrosuria is a different matter, and although some improvement in tolerance may take place so that sugar is only present in the urine intermittently, and when carefully looked for by delicate tests, complete cure does not occur, and examination of the blood will often show a high sugar content.

This week I have seen a patient whose urine was examined in the first instance owing to repeated attacks of boils; it was then found to contain a large amount of sugar. Under treatment the sugar disappeared, and when I saw him he was stated to be sugar-free. Examination of his blood showed 0.30 per cent. of sugar, however, and he had another boil forming on the back of his neck.—I am, etc.,

London, W., March 26th.

P. J. CAMMIDGE.

THE DENTISTS BILL.

SIR,—Mr. Campbell's letter, published in your issue of March 12th, p. 408, is so entirely inaccurate and misleading that it must not be allowed to pass unchallenged. Mr. Campbell states that the Dentists Act of 1878 prohibited unqualified dental practice, and that the Dentists Bill of 1920 does not. Exactly the opposite is the case.

The 1878 Act prohibited title only, and it was precisely because this course completely failed to safeguard the public that the 1920 bill was introduced, containing, as its essential feature, the strictest prohibition of unregistered practice in all its forms. As a corollary to this, in consideration of the vested interest of the present unregistered practitioners, it proposes to admit to the *Register*, under the control of the General Medical Council, all those who have been in bona fide practice for five years and are of good character. To this the British Dental Association, and the dental profession generally, strongly object, and they will use every endeavour to obtain a provision whereby the great majority of such practitioners shall not be placed on the *Register*, but upon a roll, under the control of the General Medical Council, entitling them to continue in practice, with the privilege of full registration on passing an examination of a practical character within a specified time.

Again, Mr. Campbell says, "A very glaring omission from the bill is a clause constituting a tribunal to investigate all claims for admission to the *Register*." But, Sir, Clause 2 is wholly concerned with the constitution of a board for this very purpose, and generally for the regulation of the dental profession, a board under the General Medical Council consisting of representatives of the Privy Council, the General Medical Council, the Ministry of Health, and the dental profession in Great Britain and Ireland. Surely he cannot have read the bill he is criticizing so severely!

The retention of company practice may be regretted, though it is really of little importance, as the main object of dental company practice—namely, the evasion of the law—is defeated by the provision that all the directors, managers, and operating staff must be registered dentists, and, as such, amenable individually to the jurisdiction of the General Medical Council, an exception being made in the case of directors and managers, not operators, who have acted in this capacity for a period of five years before the passing of the Act. Having no longer a reason for existence, dental companies will probably soon die out. The bill, on the whole, is a good bill. With the modifications suggested above and some others of a minor nature, it will have the support of the General Medical Council and the British Dental Association, and, if it becomes law, will be of the greatest benefit to the health of the nation and the advancement of dentistry.—I am, etc.,

London, W., March 18th.

J. H. BADCOCK.

COMMITTEE FOR THE PREVENTION OF TROPICAL DISEASES.

SIR.—In your issue of March 12th you report, under the heading, "The Future of Research in Tropical Medicine," Sir Leonard Rogers's presidential address delivered before the Section of Tropical Diseases and Parasitology of the Royal Society of Medicine on February 24th last. In this report he is quoted as saying:

"A few months ago I received an invitation to join an influential Committee for the Prevention of Tropical Diseases, but on learning from their circular that they proposed to spend £30,000 on a single expedition to a very small and rather healthy (because malaria-free) West Indian island, I felt obliged to decline the invitation, as I could not agree with such a policy. . . ."

Now, there is nothing in the circular in question which would lead anyone who reads it with ordinary attention to suppose that the policy of the committee is as stated by Sir Leonard Rogers, and it is not now, nor has it ever been, the policy of the committee to spend £30,000 "on a single expedition to a small and rather healthy . . . West Indian island." On the contrary, to quote the words of the circular, "the committee . . . proposes to begin operations by carrying out a thorough medical survey of the Lesser Antilles," and "it is expected that the survey of this group of islands will take about three years . . ."

Sir Leonard Rogers has not only misstated the objects and policy of the committee, but, not having attended any of the committee's meetings—at which his presence would have been most welcome—he has not, in fact, any accurate knowledge of what is in the minds of the members of the committee on this subject, and he has publicly criticized and stated his objection to a policy which has never been in contemplation by those concerned.

In the course of his speech Sir Leonard Rogers went on to refer to the benefits to be derived by the establishment of laboratories in various British tropical possessions, and many discussions have taken place as to what may ultimately be done in this respect. With this we are *ad idem* with him, but it is the view of the committee that (except as regards the travelling laboratories which necessarily accompany every expedition) the expedition should precede the permanent laboratory, and that this opinion has been justified in the past—as for example by the remarkable successes of the expeditions which have investigated malaria, plague, sleeping sickness, and other tropical diseases. The knowledge gained by these expeditions has been worked out at a later stage in permanent laboratories, which are in themselves, when suitably located, necessary, if expensive, institutions. That this policy has found favour in other quarters is evidenced by the previous missions (followed, it may be, by permanent laboratories) which have been sent out by the Rockefeller Foundation, as well as that now commissioned by the London School of Tropical Medicine, to carry out part of the identical West Indian scheme adumbrated by this committee and which Sir Leonard Rogers appears to condemn.

These pamphlets were sent to members of the medical profession and others likely to be interested. They were marked "Proof." It was evident, therefore, that they were not yet intended for public circulation, nor, one would have thought, were they fair matter for public criticism.—I am, etc.,

E. T. JENSEN,

Honorary Secretary, The Tropical Disease
Prevention Committee.

London, W.1, March 23rd.

CONSULTANTS' LETTERS.

SIR.—It has unfortunately become the custom of certain medical practitioners, when one of their patients has visited a consultant, to give to the patient the letter received from the consultant respecting diagnosis, prognosis, and treatment. In recent years, when a patient has consulted me a second time, I have not infrequently been surprised by his presenting me with the letter I had written to his medical attendant after the first consultation. On inquiry, I have generally found, in such cases, that my letter had been given to the patient soon after the first consultation, and, of course, carefully read by him. No doubt patients often desire to read consultants' letters, but only a minority of practitioners would give such letters to the patients.

Whatever views may be held, it is clear that if this custom increases it will be desirable that consultants in their letters to practitioners should avoid giving their diagnosis in the case of certain diseases, and avoid expressing any prognosis unless favourable. In writing such letters I try to bear in mind that the letter may possibly be read by the patient, and therefore omit much I should otherwise have said. I think it is desirable that attention should be drawn to this subject, as in the past most consultants have been in the habit of freely expressing their opinion as to diagnosis and prognosis in their letters to practitioners, and have not expected that such letters would be given to the patients.—I am, etc.,

March 18th.

PHYSICIAN.

THE LATE DR. NEWTON OF STOKE-ON-TRENT.

SIR.—Dr. Francis Morley Newton, medical officer of the Stoke-on-Trent Union Hospital, died on February 15th, 1920, leaving a widow and four children (aged, 8, 7, 6, and 1½ years). Dr. Newton was educated at Epsom and St. Bartholomew's. He suffered from asthma and diabetes and was unable to insure his life or to make provision in any other way for his family, so that their present financial position and future prospects are precarious.

A fund in aid of the widow and children has been opened under a committee having for chairman Mr. R. H. Dickson, F.R.C.S.I., Newcastle-under-Lyme (Chairman of the North Staffordshire Division of the British Medical Association, and President of the North Staffordshire Medical Society), and Mr. W. Webster, Newcastle-under-Lyme, as Secretary. The committee feels that friends or fellow-students of the late Dr. Newton might wish to contribute to the fund, and

takes the opportunity of the publicity offered by your columns to reach them. Contributions will be gratefully received and acknowledged by the Chairman or Secretary.—I am, etc.,

WM. WEBSTER,
Secretary to the Fund.

64, King Street, Newcastle, Staffordshire, March 28th.

Obituary.

LAWRENCE DREW SHAW, D.S.O., M.B., CH.B. GLAS.,
Pathologist to the London Lock Hospital.

WE regret to record the sudden death, in London on March 17th, of Dr. Lawrence Drew Shaw, D.S.O., late temporary Lieutenant-Colonel R.A.M.C., who served with great distinction in the war. He was born in 1881 and passed from the Dollar Academy to the University of Glasgow, where he graduated M.B. and Ch.B. in 1904. As a medical student he served in the South African war of 1899-1902, receiving the Queen's Medal. After qualifying he went to the Far East and settled in practice at Tientsin. On the outbreak of hostilities in 1914 he served against the Germans in North China, taking part in the siege and capture of the German fortress of Kiauchau. He then returned to Europe and took a temporary commission as lieutenant in the R.A.M.C. on March 15th, 1915, becoming captain a year later. After serving in Gallipoli he went to France in 1916, and was promoted acting lieutenant-colonel on January 29th, 1917. Colonel Shaw was awarded the D.S.O. on June 4th of that year, and fourteen months later he received a bar to the D.S.O. The official record of the second award ran as follows:

"He was placed in charge of the forward division of the combined field ambulances. Although constantly exposed to heavy shell and machine-gun fire, he organized the system of evacuation and extended it to neighbouring divisional units. By his inspiring example and disregard of danger he ensured a complete and successful evacuation of the wounded."

In June, 1919, he received the French Croix de Guerre. After demobilization he came to London and had done good work as pathologist to the London Lock Hospital.

A colleague who served with him in a field ambulance on the Somme in 1916 writes: "Lawrence Drew Shaw was an exceedingly brave man of outstanding character and ability. The war gave him the opportunity to show his mettle, and he seized it with both hands. Fearless and high-spirited, of magnificent build and physique and abounding energy, he was a born leader of men. Those who made his acquaintance early in the war knew that if his life were spared he would win high honours for courage and leadership in the field. When things were going wrong Shaw's commanding presence would steady the position. He delighted in action, and inspired others to do better than their best. He had a sound working knowledge of his profession, which he put to good use amidst the difficulties and makeshifts of practice on active service. What particularly struck many of us was his instant grasp of the medical needs of a military situation. Just as in danger he cheered up his colleagues and his men, so in dull times he was the best of companions. The epithet 'lion-hearted' seemed to fit Lawrence Drew Shaw better than any man I ever knew."

DR. THOMAS FORT, who died at Oldham on March 13th in his 68th year, received his medical education at St. Thomas's Hospital and took the diplomas of L.R.C.P. and L.M. Edin. and M.R.C.S. Eng. in 1877. He was a native of Preston and went to Oldham as a young man, where he built up a large practice and became very popular among a large circle of friends. He held the posts of certifying factory surgeon and police surgeon for about forty years, and about fifteen years ago was appointed surgeon to the post office. For many years he was associated with the volunteer movement, receiving the Volunteer Decoration for twenty-three years' service before the formation of the Territorial Force. He retired on account of advancing years shortly before the outbreak of the recent war, with the rank of honorary surgeon-colonel. He was a member of the Oldham Division of the British Medical Association, and is survived by his widow, a daughter, and two sons, both of whom are members of the medical profession.

DR. JOHN DROUGHT KENNY, whose death occurred on March 9th at his residence, The Grange, Wickersley, near Rotherham, was a native of Ireland, and obtained his medical education at Queen's College, Galway, and at the Ledwich School and Adelaide Hospital, Dublin. In 1884 he graduated M.D., M.Ch., R.U.I., and L.M. Rotunda, and in 1887 went to Yorkshire, where, after an assistant-ship, he settled down in practice in the village of Treeton, remaining there for the next twenty-five years. He built up a large and busy practice, and gained the esteem and affection of all classes by his cheery good-nature and unsparring devotion to his work. The poor and needy ever found him a ready and generous friend, and it will long live in the memory of the villagers how he helped them with money and provisions during a long and serious coal strike. His patients and friends showed their appreciation by presenting him with a handsome motor car when he left them, in 1912, to take up practice in Wickersley. He held numerous appointments under the Guardians, the Yorkshire Coalowners' Indemnity Company and various colliery companies, and he also took much interest in ambulance work. He was a staunch and sincere churchman and rendered many valuable services to the Church of England. His death, which occurred from pneumonia after a few days' illness, came as a great shock to his many friends. He is survived by his widow, with whom much sympathy has been expressed.

DR. HARRY HOLLIS died on March 12th, aged 54, at Redenhall, Norfolk, where he had gone on retiring from practice at Wellingborough last summer. He was born in Derbyshire, and studied medicine at St. George's Hospital and the University of Cambridge. He graduated B.A. in 1890, M.B., B.Ch. in 1893, and M.D. in 1898. After holding house appointments at St. George's Hospital and the Derbyshire Hospital, he became house-surgeon to the Northampton General Hospital, and ultimately removed to Wellingborough, where he joined Dr. Audland in partnership. Dr. Hollis had been a member of the old school board, a governor of Wellingborough School, and was one of the founders of the local Children's Welfare Centre. He was never very robust in health, and two years ago had an illness which led to his retirement. As a mark of esteem in which he was held, the townspeople of Wellingborough raised £200 as a testimonial to Dr. Hollis's work in the district. Whilst in active practice he was a member of the Northamptonshire Division of the British Medical Association. He is survived by his widow, two daughters, and a son.

THE death took place, at a nursing home in Edinburgh, on March 12th of Dr. ALEXANDER VEITCH, a well-known medical practitioner of Edinburgh. Educated at Edinburgh University, where he graduated M.B., C.M. in 1890, he subsequently acquired a large general practice in the city. Latterly he acted as a medical referee in workmen's compensation cases, and his pronouncements in these made him widely known. Dr. Veitch had more than the usual general practitioner's skill in surgical operative work, and he had also an extensive panel practice, being one of the first practitioners to take service under the Insurance Act. Of a kindly and philanthropic disposition, a lover of nature and a student of literature, he was widely esteemed. He took a keen interest in motoring in the early days of the industry, and was one of the first to make use of a motor car in his professional work.

THE death is announced of Mr. DAVID MORGAN BEDDOE of Cairo. He was born in December, 1869, and received his medical education at Guy's Hospital. He took the diplomas of M.R.C.S., L.R.C.P. Lond. in 1893, and that of F.R.C.S. Eng. two years later. After serving as house-surgeon at Guy's Hospital and at the Newport Infirmary he went to Egypt for the benefit of his health and soon established a successful practice in Cairo, where he became surgeon to the Anglo-American Hospital. Mr. Beddoe's literary tastes were well known; he was the author of several works of fiction, and of *A War Surgeon at the Red Cross Hospital, Cairo*, describing some of his experiences during the war.

THE LATE DR. W. IRONSIDE BRUCE.

AN old friend and colleague sends an appreciation of Dr. Ironside Bruce, of whom an obituary notice appeared in our last issue: When many years ago the writer first met Ironside Bruce it was as his chief clinical assistant at Charing Cross Hospital. At that time the picture was that of a young man remarkable for his quickness of action and manner, with rapid and incisive speech, and with just a piquant flavour of Scotland on his tongue. Endowed with marvellous energy, he was wonderfully patient with others and kind and considerate to his subordinates. To his clinical assistants Bruce was invariably helpful, always at their back, yet urging them on to work out things for themselves, and this, not from any inclination to shirk work, but because he appreciated the fact that the only way to teach people was to let them find their own legs. The wealth of Bruce's knowledge in his own sphere of work was shown in the excellence of his lectures and demonstrations to men who were working for the diploma in medical radiology of Cambridge University. On the subject of the necessity for comprehensive teaching of the radiologists of the future, there was no greater enthusiast than Bruce; only a week ago the writer received a message from him that he hoped he might be able to give some lectures in the ensuing term. How far the strenuous work done by Ironside Bruce during the war helped to lower his vitality the writer can only surmise; he does, however, know that from the enormous x-ray department of the King George (Military) Hospital, with but short and infrequent rests, Bruce was never absent on one of his appointed days. To the writer Bruce has never appeared to have been quite the same man since that time of terrible stress. Ironside Bruce was a clever man, a man of shrewd judgement, and withal a man of the most winning personality. Had he been spared there is no knowing what valuable records he might have left behind him. The stress of busy practice left him no time to give to the world what he could have given, and what, as he told the writer, he hoped to give. That he died a martyr to the science he loved is a truism; that a life so full of great possibilities should have been sacrificed is nothing short of a calamity. It is for us to do what we can to lessen, if possible, this sacrifice of life among x-ray workers.

The following message from His Majesty has been received by the Earl of Lonsdale, Treasurer of Charing Cross Hospital: "The King has learnt with much regret of the tragic death of Dr. Ironside Bruce, radiologist to the Charing Cross Hospital, and I am commanded to convey to you and the hospital staff His Majesty's sincere sympathy in the loss of so brilliant a physician, who sacrificed his life in the cause of science and humanity."

The post-graduates attending the courses in radiology for the Cambridge diploma at the Fellowship of Medicine and Post-Graduate Medical Association adopted, on March 23rd, a resolution expressing their sympathy with the widow, and putting on record their admiration of Dr. Ironside Bruce, "whose genial good-nature, ability as a teacher, and self-sacrificing devotion to his work endeared him to all with whom he came in contact."

THE death is announced of Mr. C. A. NANJAPA, I.M.S. Colonel J. Smyth, I.M.S., retired, formerly senior surgeon and sanitary commissioner, Mysore, writes:

C. A. Nanjapa, I.M.S., M.R.C.S., L.R.C.P., senior surgeon to the government of His Highness the Maharaja of Mysore, passed away on February 19th, 1921. He had just been promoted to the highest position in His Highness's medical service, yet a young man full of zeal and energy and high determination in regard to the duties that now devolved upon him. He spent a week with us here last year. He was obviously then much out of health, and was full of appreciation of the kindness of the profession in London to him in connexion with his disability. The loss of his only son and child on the way to England was a severe blow to both parents. And now the end has come. Of a very bright optimistic disposition, yet never anxious to appear much in public, he seldom published his work. It sufficed for him that he did his work conscientiously and well. In the hospital his cheery hearty manner contributed much to the contentment and comfort of the patients. He did not grow rich; to have a competence suited him. A gentleman in all respects, he left good impressions wherever he went. Educated in Madras, London and New York, and specializing in electro-therapeutics, his knowledge of men was as wide as his knowledge of medicine. He was absolutely free from suspicion or mistrust in Englishmen. He gave us credit for entire sincerity and a desire to be true to our salt. He was therefore a personal friend of many Englishmen, whose hearts were won by the straightforward manly spirit he always evinced.

Universities and Colleges.

UNIVERSITY OF CAMBRIDGE.

Diploma of Psychological Medicine.

A FIVE weeks' revision course for the Diploma examination will be held in Cambridge from July 18th to August 20th. The course will include lectures and laboratory work on the Anatomy and Physiology of the Central Nervous System (Dr. Thacker and on Psychology (Dr. Lowson) for Part I of the examination, and lectures and clinical work on Psychopathology (Dr. Myers and Dr. Prideaux) and on Mental Diseases (Dr. Archdale) for Part II.

The fee for the whole course is 12 guineas. That for the course for Part I or Part II alone is 6 guineas. The examination for Part I (Anatomy and Physiology of the Nervous System, and Psychology) is held in October and that for Part II (Neurology and Psychiatry) in December. Further information may be obtained from the Secretary to the D.P.M. Committee, Psychological Laboratory, Downing Street, Cambridge.

UNIVERSITY OF DURHAM.

THE following candidates have been approved at the examination indicated:

THIRD M.B., B.S. (*Materia Medica, Pharmacology and Pharmacy; Public Health; Medical Jurisprudence; Pathology and Elementary Bacteriology*).—J. N. Alexander, Florence Bentham, R. W. Locke, G. C. E. Reffell, C. A. Wilson, Eleanor H. Wylam, Ella L. Young.

UNIVERSITY OF LIVERPOOL.

THE following candidates have been approved at the examinations indicated:

M.D.—Amy Hodgson, N. W. Walmsley.
FINAL M.B., CH.B.—Class II.—J. G. L. Jones, Part III. Eileen Dowling, F. H. Edwards, S. Farris, W. S. Gilmour, H. T. Hughes, R. M. Jones, Florence M. Lampert, R. F. J. Martio, F. G. Pailthorpe, J. H. Pottinger, A. McK. Reid, J. C. Twomey, Part II. G. C. Bhatia, Eleanor E. Briant, H. R. Chibber, C. Cookson, Part I. Ethel Ashton, H. R. Chibber, G. Clark, H. M. Cohen, R. W. Cowie, J. Elsohn, I. S. Fox, H. S. Gordon, R. C. Gubbins, W. D. Jeaus, T. Knowles, Mary E. Nosworthy, G. Sanders, S. G. Sheir, Mary D. H. Sheridan, W. T. de V. Thomson, Mary G. T. Williams, D. A. Woodson.
D.P.H.—A. J. Hawes, J. O. Murray, L. B. Stott.
D.T.M.—R. Nixon, A. S. Richmond, J. M. Skinner, R. B. Stewart, Marion Thomson.
D.M.R. AND E.—C. C. Anderson, J. H. Mather, R. E. Roberts, R. I. C. Rodgers.

* Honours in Obstetrics.

† Honours in Forensic Medicine and Toxicology.

UNIVERSITY OF MANCHESTER.

THE following candidates have been approved at the examinations indicated:

THIRD M.B. AND CH.B. (*General Pathology and Morbid Anatomy*).—Elsie C. Begg, L. Boyars, F. W. W. Fox, E. S. Frischmann, R. Handley, Mary Kent, C. B. Kirkbride, G. A. Lord, Greta Lowe, G. L. Meachim, A. A. Pomfret, Eleanor P. Smith, J. H. Struthers, C. B. V. Walker.
D.P.H.—Marion Draper, J. H. Sheldon.

UNIVERSITY OF EDINBURGH.

AT the graduation ceremonial held in the McEwan Hall on March 24th the degrees of M.B., Ch.B., were conferred in *absentia* upon Bernard Friedman.

UNIVERSITY OF ABERDEEN.

THE following have passed the final professional examination in medicine:

C. D. Allan, J. J. H. Anderson, N. C. Bodenstein, C. K. Chen, *J. Craig, Lilian F. Gall, R. K. Grant, G. W. Hay, *Eleonora M. P. Law, Margaret Lipp, D. G. MacDonald, A. MacKay, Elsie Mackie, Katherine C. Van de Merwe, Mary G. Milne, Dorothy Mitchell, John I. Moir, Marion E. Mowat, J. M. H. Murray, Janet C. Nicol, *Mary M. Pyper, A. E. Reid, E. N. D. Repper, *J. P. G. Rossouw, G. Saint, N. C. Simpson, G. V. G. Smith, I. R. Stark, *A. L. G. Thomson Butterworth, I. S. Thomson, A. B. Wood.

* With distinction.

ROYAL COLLEGE OF PHYSICIANS OF LONDON.

An extraordinary Comitia of the Royal College of Physicians of London was held on Monday, March 21st, at 5 p.m., with the President, Sir Norman Moore, Bt., in the chair.

The annual address was delivered by the President, who referred eloquently to the seven Fellows who had died during the past year—Dr. M. Handfield Jones, Dr. Philip John Hensley, Dr. David Lloyd Roberts, Dr. William Murray, Sir Frederick Taylor, Dr. William Odling, and Sir Felix Semon.

The Comitia then proceeded to the election of the President, and Sir Norman Moore was re-elected.

Licence to practise was granted to Evelyn Francis Bebbington, of Liverpool University. The President then dissolved the Comitia.

ROYAL COLLEGE OF SURGEONS OF ENGLAND.
APPROACHING ELECTION OF COUNCIL.

FOUR vacancies on the Council of the Royal College of Surgeons will be filled on Thursday, July 7th. The outgoing members are Sir George Makins and Mr. Ernest Lane, who do not seek re-election, and Mr. Waring and Mr. Burghard, who are coming forward again.

The constitution of the Council at present is as follows:

President.—Sir Anthony Bowlby, K.C.B., K.C.M.G., K.C.V.O., C. (1) 1904, (2) 1912, (3) 1920. Pres. 1920.

Vice-Presidents.—Sir Charles A. Ballance, K.C.M.G., C.B., M.V.O., C. (1) 1910, (2) 1914. Sir John Bland-Sutton, C. (1) 1910, (2) 1918.

Other Members of Council.—Sir George H. Makins, G.C.M.G., C.B., C. (1) 1903, (2) 1911, Pres. 1917; Sir Charters J. Symonds, K.B.E., C.B., C. (1) 1907, (2) 1915; Mr. W. F. Haslam, C. (1) 1908, (2) 1916; Sir D'Arcy Power, K.B.E., C. (1) 1912, (2) 1920; Sir Berkeley G. A. Moynihan, K.C.M.G., C.B., C. (1) 1912 (substitute), (2) 1919; Mr. James Ernest Lane, C. 1913; Mr. H. J. Waring, C. 1913; Sir William Thorburn, K.B.E., C.B., C.M.G., C. 1914; Mr. W. McAdam Eccles, C. 1914; Sir Charles Ryall, C.B.E., C. (1) 1914 (substitute), (2) 1915; Mr. Walter G. Spencer, O.B.E., C. (1) 1915 (substitute), (2) 1918; Mr. F. F. Burghard, C.B., C. 1915 (as substitute till 1921); Sir Herbert P. Waterhouse, C. 1915; Mr. T. H. Openshaw, C.B., C.M.G., C. 1916; Mr. Raymond Johnson, O.B.E., C. 1915; Mr. V. Warren Low, C.B., C. (1) 1916 (substitute), (2) 1917; Mr. J. Sherren, C.B.E., C. 1917; Sir John Lynn-Thomas, K.B.E., C.B., C.M.G., C. 1918 (substitute till 1925); Mr. Ernest W. Hey Groves, C. 1918; Sir Cuthbert S. Wallace, K.C.M.G., C.B., C. 1919; Mr. F. J. Steward, C. 1920.

The medical schools, etc., are represented as follows:

<i>London:</i>	
St. Bartholomew's	4
Charing Cross	1
Guy's	2
King's College	2
London	1
Middlesex	2
St. Mary's	3
St. Thomas's	3
University College	1
Westminster	1
Special London Hospital	1
Total London... ..	19
<i>Provincial:</i>	
Birmingham	1
Bristol	1
Cardiff	1
Leeds	1
Manchester	1
Total Provincial	5
Total Council... ..	24

The Services.

ADDITIONAL PAY FOR OFFICERS ON COMMITTEES.

AN Army Order provides that a field officer on full pay who is appointed to serve on a committee, or to act as its secretary, in virtue of possessing special scientific knowledge not acquired as part of his normal military duties, will receive 15s. additional pay for each day on which such committee sits. A captain or subaltern serving in similar circumstances will have additional pay of 10s. a day.

R.N. MEDICAL CLUB DINNER.

THE annual dinner of the Royal Navy Medical Club will take place at the Hotel Cecil, London, on Thursday, April 14th, 1921, at 7.30 for 8 p.m. Members who wish to be present are asked to inform the Honorary Secretary, Royal Navy Medical Club, 1, Lake Buildings, St. James's Park, S.W.1, not later than seven clear days before that date.

HONOURS.

FOREIGN DECORATIONS.

THE following are among the decorations and medals awarded by the Allied Powers for distinguished services rendered during the war 1914-19:

By the King of the Belgians.
Ordre de Léopold—Officier: Lieut.-Colonel John Kyffin, T.D., R.A.M.C.(T.F.). *Ordre de la Couronne*—Officier: Temporary (honorary) Lieut.-Colonel Edward Stewart, R.A.M.C.; Colonel Sir John Hewat, Assistant Director of Medical Services, South African Defence Force.

By the President of the French Republic.
Médaille des Epidémies—en argent: Temporary Major (acting Lieut.-Colonel) George D. Gray, O.B.E., R.A.M.C.; en bronze: Temporary Captains Clement A. Hughes, Charles F. Strange, and Herbert Tomlin, R.A.M.C. *Palme Académie*—Officier: Captain William Adams Smith, C.A.M.C.

By the King of Italy.
Order of the Crown of Italy—Officer: Brevet Lieut.-Colonel Frederick S. Breveton, C.B.E., R.A.M.C. *Chevalier*: Captain Hugh Richard Phillips (late Surgeon R.N.), and Captain R.A.M.C.I.

Medical News.

AT a representative council meeting of the National Council for Combating Venereal Diseases, held on March 23rd, at the Royal Society of Medicine, Lord Gorell, President of the Council, made a full statement as to the relations now subsisting between the National Council and the Society for the Prevention of Venereal Disease. A memorandum (summarized in our last issue at p. 476) defining the policy of the National Council, which had been submitted to and received the approval of the Minister of Health, was considered in view of the report of the Special Committee of the National Birth Rate Commission. After discussion and the moving of an amendment, which was rejected by 41 votes to 8, the memorandum was adopted. Reports were received of the valuable work carried out under the aegis of the Colonial Office by the three Commissions of the National Council which visited Shanghai, Hong Kong, Singapore, Ceylon, Malta, Gibraltar, Jamaica, Barbados, Grenada, Trinidad, Demerara, and Bermuda.

THE King, with the advice of his Privy Council, has nominated Sir Francis Champneys, Bt., M.D., to be, for a further term of five years from May 23rd, 1921, a member of the General Medical Council.

A COURSE of twelve practical demonstrations, on the management and feeding of infants and young children, for medical practitioners will be given at the St. Marylebone General Dispensary, Welbeck Street, W.1, by Dr. Eric Pritchard, on Tuesdays and Thursdays, at 10.30 a.m. and 3 p.m. respectively, commencing on April 5th. The fee for the course is two guineas, and opportunities will be afforded to students of visiting on Saturday afternoons the Nursery Training School, 1, Wellgarth Road, Golder's Green, and seeing there the methods employed in dealing with infants.

AT the annual meeting of the Society for the Study of Inebriety, to be held at the rooms of the Medical Society of London, 11, Chandos Street, W., on Tuesday, April 12th, at 4 p.m., Dr. H. H. Dale, F.R.S., will open a discussion on the use of alcohol in medicine.

A SPECIAL post-graduate course will be held at the North-East London Post-graduate College from Monday, April 25th, to Saturday, May 7th, inclusive. At 10.30 a.m. and at 11.45 a.m. each day practical demonstrations will be given on clinical and laboratory methods applicable in medical practice. At 2 p.m. demonstrations will be given on groups of cases illustrating special subjects, and at 3 p.m. on selected cases in various departments of practice. At 4.30 p.m. there will be either a clinical lecture (by Sir William Hale-White, Sir Thomas Oliver, Sir Henry Gauvain, Mr. H. D. Gillies, Dr. P. Manson-Bahr, Dr. Frederic Thomson, and others), or clinical consultations on obscure medical and surgical cases. On Saturdays demonstrations will be given on the early diagnosis of the infectious fevers at the North-Eastern Fever Hospital, St. Ann's Road, London, N., and on cases of insanity associated with epilepsy at the L.C.C. Mental Hospital, New Southgate, London, N. Luncheon will be obtainable in the neighbourhood and tea will be provided each day at 4 p.m. The fee for the course is 3 guineas or 2 guineas for either week. The lectures at 4.30 p.m. will be free to qualified medical practitioners. Further information may be obtained from the Dean of the College at the Prince of Wales's General Hospital, Tottenham, N.15.

WE are asked to state that the meeting of the Section of Psychiatry of the Royal Society of Medicine arranged for April 12th will not be held.

DR. ARTHUR ALFONSO MILLER has received the Cross of Chevalier of the Legion of Honour conferred upon him by the President of the French Republic in recognition of his services to the French sick and wounded in the late war.

DR. ROBERT SHAND TURNER, who is leaving Keith, where he has practised for over fifty years, to reside in Edinburgh, has been presented by his friends and patients with a cheque of £360, and Mrs. Turner with an inscribed silver casket, as a mark of their esteem and regard.

DR. T. HENRY JONES, on the occasion of his retirement from the office of County M.O.H. for Surrey, has been presented by the members of the County Council and committees thereof with two Persian rugs and an illuminated address, and Mrs. Jones with a silver kettle and hot-water jug, as a mark of esteem.

THE annual general meeting of the London and Counties Medical Protection Society will be held at the offices of the Society, 32, Craven Street, Strand, W.C.2, on Wednesday, April 6th, at 4 p.m.

DR. F. E. WYNNE, on the occasion of his relinquishing the medical officership of health for the county borough of Wigan to become medical officer of health for Sheffield, has been presented by the various staffs of the Wigan Health Department with a silver tea service as a mark of appreciation and esteem.

The second annual reunion of the Workers for Serbia will take the form of a dinner and dance to be held at the Wharnciffe Rooms, Hotel Great Central, on Tuesday, April 19th, at 7 p.m. Colonel Sir Courtauld Thomson, K.B.E., Chief Commissioner of the British Red Cross for Malta and the Near East, 1915-1919, will be in the chair, and a large gathering of the medical men and women who served with the medical missions or with the R.A.M.C. units attached to the Royal Serbian Army is hoped for. Tickets, price one guinea each, may be obtained from the honorary secretary, Miss Marx, 24, Melcombe Court, Dorset Square, N.W.1.

Letters, Notes, and Answers.

As, owing to printing difficulties, the JOURNAL must be sent to press earlier than hitherto, it is essential that communications intended for the current issue should be received by the first post on Tuesday, and lengthy documents on Monday.

ORIGINAL ARTICLES and LETTERS forwarded for publication are understood to be offered to the BRITISH MEDICAL JOURNAL alone unless the contrary be stated.

CORRESPONDENTS who wish notice to be taken of their communications should authenticate them with their names—of course not necessarily for publication.

AUTHORS desiring reprints of their articles published in the BRITISH MEDICAL JOURNAL are requested to communicate with the Office, 429, Strand, W.C.2, on receipt of proof.

In order to avoid delay, it is particularly requested that ALL letters on the editorial business of the JOURNAL be addressed to the Editor at the Office of the JOURNAL.

THE postal address of the BRITISH MEDICAL ASSOCIATION and BRITISH MEDICAL JOURNAL is 429, Strand, London, W.C.2. The telegraphic addresses are:

1. EDITOR OF THE BRITISH MEDICAL JOURNAL, *Aitology, Westrand, London*; telephone, 2630, Gerrard.

2. FINANCIAL SECRETARY AND BUSINESS MANAGER (Advertisements, etc.), *Articulate, Westrand, London*; telephone, 2630, Gerrard.

3. MEDICAL SECRETARY, *Medisecra, Westrand, London*; telephone, 2630, Gerrard. The address of the Irish Office of the British Medical Association is 16, South Frederick Street, Dublin (telegrams: *Bacillus, Dublin*; telephone, 4737, Dublin), and of the Scottish Office, 6, Rutland Square, Edinburgh (telegrams: *Associate, Edinburgh*; telephone, 4361, Central).

QUERIES AND ANSWERS.

TRUSS FITTING.

DR. J. J. E. BIGGS, O.B.E. (Cardiff) writes: Can any of your readers give me any information as to how to get a patient measured for a truss? The patient is a female, aged, feeble and emaciated, with an old-standing spinal curvature; there is a femoral and an indirect inguinal hernia in the right side. Most of the instrument makers I have tried have attempted to make the patient fit their pre-conceived notion of a truss instead of trying to make the truss fit the patient. It is impossible for the patient to travel to London for fitting. Before the war one firm, I remember, supplied me with a soft metal piece of wire, marked in inches, which could be firmly and accurately modelled on the patient and removed without altering the contour.

(1) It is doubtful whether an aged, feeble, scoliotic patient with a hernia is a suitable case for any spring-truss. (2) When fitting at or by the maker is impossible, it is a good plan to make use of the soft metal graduated cyrtometer, listed in all surgical instrument catalogues. The cyrtometer can be folded and sent to the maker in a box, or its curvature, when fitted, can be traced on paper and so reach the truss-maker. (3) If the truss when received does not fit exactly, the medical man can generally do what the maker would do—bend the spring appropriately with his hands, perhaps with the aid of a vice or improvised equivalent. The resources of a "car" are nearly always adequate, for the "temper" of the spring is not as a rule very high. (4) When a spring-truss is unsuitable it is sometimes easy to attain the desired support by using a more or less triangular pad, held in place by webbing and elastic straps attached to the three corners, in the manner adopted by one of the well known patent "cures." (5) In the presence of emaciation it may be found most satisfactory to use a spica bandage of crêpe over an appropriate pad. (6) Makers certainly sometimes expect patients to be content with unsuccessful efforts, but when they do not see the patient they may fairly expect the doctor to do something towards fitting the truss after receipt.

INCOME TAX.

"S. H. S." inquires whether it is correct for the earnings of his partner and himself to be assessed in one sum, less the aggregate allowances for both.

The assessment must be made in one sum on the profits of a partnership practice, but the local inspector will usually supply on request such supplementary particulars as are necessary to enable the net duty payable to be correctly apportioned between the partners. The abolition of this inconvenient system of assessment was urged by the British Medical Association representative before the Royal Commission on Income Tax, and the suggestion was favourably received.

"M.D. EDIN." bought a car in 1910 for £250, and sold it for that sum in 1920, buying a new one for £500. He asks if he can deduct the £350 as an expense.

An official witness before the Royal Commission on Income Tax stated that, provided an improvement was not effected, the actual cost of the replacement of a machine would be allowed. Assuming that the new car is not of superior power or quality, "M.D. Edin." appears to be entitled to deduct the £350.

LETTERS, NOTES, ETC.

THE STETHOSCOPE IN FRANCE.

INASMUCH as the stethoscope is a French invention it is always something of a surprise to the British or American medical traveller in France to find that the binaural stethoscope is virtually unknown there, and the use of even the single wooden implement is restricted to investigation of difficult heart sounds. There are, of course, physicians in this country, especially of the older generation, who prefer to use the wooden stethoscope, particularly in the examination of the heart, but they are the exceptions. French doctors defend their neglect of the binaural stethoscope on the ground that the respiratory and other sounds are changed and distorted by passage through the tubing. To this it may be replied that, although the sounds are indeed modified, so is the voice of a friend heard through the telephone; yet this fact does not prevent our recognizing his voice, detecting his emotions, and understanding his speech. Moreover, no great amount of practice is needed to learn to distinguish extraneous or fortuitous sounds heard through the stethoscope. But the binaural instrument has certain positive advantages. Thus, it greatly facilitates examination, since one can "run over" the chest in a very short space of time; again, in hospital practice—particularly in French hospitals, where it is not the custom to give patients a bath on admission—the flexible pattern enables the physician or student to keep at arm's length from his patient, and his attention is less distracted by the noises around him. There are advantages, too, from the patient's point of view, for it is common experience in French hospitals to see a man seriously ill from typhoid fever or heart disease compelled to sit up in bed in order to permit of auscultation of the base of the lung, whereas when the binaural stethoscope is used it suffices to turn him on his side. Furthermore, the flexible stethoscope can be applied to the chest with a lighter touch than the rigid pattern. We have heard it said that our French colleagues' disregard for the binaural stethoscope must be due to a *mot d'ordre*; for it is to be observed in all hospitals controlled by French medical men, from Paris to Algiers, from Lille to Bordeaux, and even students cannot be induced to give the instrument a trial, so strong is the force of the example set by their chiefs.

VACANCIES.

NOTIFICATIONS of offices vacant in universities, medical colleges, and of vacant resident and other appointments at hospitals, will be found at pages 33, 36, 37, 38, 39, and 40 of our advertisement columns, and advertisements as to partnerships, assistantships, and locum tenencies at pages 34 and 35.

THE appointments of certifying factory surgeons at Canterbury (Kent) and West Bromwich (Stafford) are vacant.

SCALE OF CHARGES FOR ADVERTISEMENTS IN THE BRITISH MEDICAL JOURNAL.

	£	s.	d.
Six lines and under	0 9 0
Each additional line	0 1 6
Whole single column (three columns to page) ...	7	10	0
Half single column ...	3	15	0
Half page ...	10	0	0
Whole page ...	20	0	0

An average line contains six words.

All remittances by Post Office Orders must be made payable to the British Medical Association at the General Post Office, London. No responsibility will be accepted for any such remittance not so safeguarded.

Advertisements should be delivered, addressed to the Manager, 429, Strand, London, not later than the first post on Tuesday morning preceding publication, and, if not paid for at the time, should be accompanied by a reference.

NOTE.—It is against the rules of the Post Office to receive *poste restante* letters addressed either in initials or numbers.

A Clinical Lecture ON THE ORTHOPAEDIC TREATMENT OF POLIOMYELITIS.*

BY

H. A. T. FAIRBANK, D.S.O., O.B.E., M.S., ETC.,
SENIOR ORTHOPAEDIC SURGEON TO KING'S COLLEGE HOSPITAL;
SURGEON TO THE HOSPITAL FOR SICK CHILDREN,
GREAT ORMOND STREET.

The surgical treatment of poliomyelitis includes a great deal which can be carried out by any practitioner, whether physician, surgeon, or both.

It is customary for purposes of treatment to divide the course of a case into three stages: the early, acute stage, which lasts while there is pain and tenderness in the muscles; the second or convalescent stage, during which the recovery of power is taking place—it lasts to the end of the first and sometimes the end of the second year; and the third stage, which begins after the lapse of two years: until this stage all reconstructive surgery is delayed.

FIRST STAGE.

During the first stage the spinal cord is the seat of a haemorrhagic inflammation, which is gradually subsiding. Those anterior horn cells which have been only temporarily thrown out of action gradually return to health and perform their normal functions, while others which have been damaged too severely to recover degenerate. The flaccid paralysis affects a more or less wide range of muscles—very often a much wider range than would be suspected from an examination of the patient a few months later.

Unfortunately we cannot tell at first which muscles will recover rapidly, which will recover more or less completely though slowly, and which will remain completely paralysed. Therefore we must treat all the muscles alike until such time as recovery indicates which require special care.

The first essential of treatment is rest, both for the spinal cord and the affected muscles. All patients are best kept in bed for a time; Batten¹ insisted on three weeks, even in mild cases. Steps should be taken to provide absolute rest for all the affected muscles, and this involves rest for all their opponents as well should these not be paralysed. There seems to be a great tendency to delay doing anything, particularly in a bad case, until the acute stage has passed off. This is, I think, a mistake. Splints or other fixation apparatus should be applied at the earliest possible moment, the limbs being fixed in the neutral position. Without fixation deformities are certain to occur. The apophthegm, "Prevention is better than cure," applies with as much force in this instance as in any other. The neutral position is one in which, as far as possible, no one muscle or group of muscles around a joint is favoured to the detriment of others. Thus the foot is put at a right angle, the knees are straight, the hips are straight and the spine flat. The position of the hip and knee joints can be assured by rest on a flat bed, with a towel and a couple of sandbags to keep the knee from flexing, but the feet require some simple splint of tin, wood or plaster-of-Paris to hold them at the right angle. As regards the arm, the best position is one of abduction of the shoulder, flexion of the elbow to a right angle, supination of the forearm and dorsiflexion of the wrist. This position is not entirely governed by a desire to find the neutral position, but partly with an eye to favouring those muscles which we know recover with difficulty, and of which the recovery is more important than that of their opponents; for instance, the deltoid, biceps, etc. This position can be retained by sandbags while the patient is lying flat, but a splint is necessary as soon as he sits or stands. The simplest splint is one made of tin. Such splints serve a double purpose—to give rest and to prevent deformity.

As regards the correction of deformity at this stage, it will be found easy to stretch contracted muscles. When the muscles are still tender, except in cases where this tenderness is unduly prolonged, very gentle persuasive

manipulations with fixation on a splint which is slightly altered in shape each day will achieve correction of the deformity. The stretching is painful, and must be done with the greatest gentleness; if the foot is fixed in the position which is the best possible one day, it will usually be found possible to improve this slightly the next.

Lovett and Richardson,² in 604 cases, found that in 49 per cent. the pain and tenderness had disappeared by the end of the second week, and in a further 13 per cent. by the end of the fourth week, and that it was quite exceptional to find any tenderness after the second month.

Massage should be carried out with the greatest gentleness, and one must be guided by its effect in each case. If the patient cannot stand even gentle massage, it must be discontinued. Lovett³ considers it harmful, as since it is painful it irritates an already inflamed cord, and he forbids it absolutely while there is tenderness. In the majority of cases, if done properly, it should not be painful and can do no harm, and it unquestionably prevents some of the wasting of the muscles. Electricity is useless at this stage.

A word of caution seems to be called for with regard to the spinal muscles. There are undoubtedly cases which develop a spinal curve while still lying flat on the back, the position they have been in since the onset of the disease; there are others in which the onset of lateral curvature has been less rapid, but in which a distinct cause is present in the unequal affection or recovery of the muscles of the two sides of the body, or of the two legs, etc.; but there are some cases of scoliosis seen at a later stage which make one wonder whether they ought not to have been prevented. In such cases a special cause for the deformity is absent, all portions of the erector spinae acting well. One cannot exclude unequal power in the two erectors spinae as the cause, but this could equally well have resulted from the stretching of the muscles on the convex side of the curve and relaxation of those on the concave side—that is, it is the result and not the cause of the curvature. A case in which the spinal muscles, though slightly affected at first, have recovered, but still remain weak when the child first begins to sit up, is just the subject for scoliosis. I would urge the advisability of raising the child to a sitting position slowly and gradually by means of a bed rest and pillows. The spinal muscles should be massaged, and any paresis and tendency to curvature looked for.

The possible causes of scoliosis in poliomyelitis cases are:

1. Paralysis or weakness of (a) the spinal muscles on one side; (b) the abdominal muscles in one loin, and of the intercostals on one side; (c) of one psoas (as first suggested by Elmslie).
2. General weakness of all the spinal and accessory muscles.
3. Contracture of one hip.
4. Shortness of one leg.
5. Paralysis of one shoulder.

SECOND STAGE.

There is no question that signs of recovery may appear in muscles previously paralysed up to the end of the first year. In a case treated well throughout, a muscle which is absolutely paralysed after twelve months must be regarded as hopeless (Jones).⁴ During the second year further recovery may take place in all those which have to some extent recovered, but a muscle which remains paralysed for many months before showing any return of power will never be of much use to the patient.

The treatment during the second stage comprises the following: Keeping the part warm, relaxation of the paralysed or weak muscles, massage and re-education of muscles, to which must be added "correction of deformity," if such has been allowed to occur. Additional covering for a paralysed limb is essential even in the summer months. The difference in power of a cold and a warm muscle is surprising.

The next point is, in my opinion, the most important. Without adequate support recovery is bound to be far from complete, and will be coupled with deformity. Unfortunately the efficient use of splints is a factor in treatment most often neglected. It is not at all uncommon to find a patient in whom scoliosis has occurred provided with beautiful walking apparatus, but the use of night splints has been neglected. Splints are more efficient correctors of a tendency to deformity than any walking

* Delivered at the Hospital for Sick Children, Great Ormond Street, on October 28th, 1920.

apparatus. Thanks largely to Sir Robert Jones's repeated utterances on this subject, it is now generally agreed that avoidance of over-stretching of a paralysed muscle, particularly in the early stages of its recovery, is essential for good recovery. The wisdom or necessity of carrying this to the extent of never for an instant allowing any paralysed or weak muscle to be stretched even to a moderate degree, has been questioned by Langley.⁵ Whether this prevention of over-stretching should be carried to the extent of absolute relaxation—or, in other words, whether the neutral position is sufficient—or whether the limb should be put in a position to relax the paralysed muscles at the expense of their unparalysed opponents, is still an open question. If all the muscles of a limb are paralysed, the neutral position is, of course, the correct one; but supposing the anterior tibial group paralysed, and the tendo Achillis muscles acting, there is a strong tendency to equinus, and I think the best position is one of slight calcaneus, for a certain amount of slipping of bandages can then occur without the foot dropping beyond a right angle. Moreover, we not only want to see power returning in the anterior muscles, but we want to see equilibrium established between the anterior and posterior muscles at the earliest possible moment, so that apparatus may be gradually discarded. Some weakening by over-stretching of the opponents, therefore, is not altogether a bad thing in such a case.

One word of warning must be given as to the bandages or straps used to hold a limb in a splint. In the case of the leg these should encircle the foot and ankle and, at most, the lower third of the leg; the muscles themselves should be free of all pressure.

The splints must be left on day and night, and removed only for washing, massage, etc., when the position of the limb should be maintained by the hand of the attendant so long as any marked degree of weakness persists. The different methods of fixation for different parts of the body will be referred to later. As soon as recovery has progressed sufficiently walking should be encouraged, suitable apparatus being employed. So important do I consider the fixation of the part and the relaxation of the paralysed muscles that in certain difficult cases where the supervision of splints, etc., has been most inadequate I have applied an irremovable plaster-of-Paris case, with gratifying results; on removal of the plaster a month or two later, a muscle which had previously shown no flicker of voluntary power has been found acting strongly. This method may be used with advantage in cases other than poliomyelitis, where one muscle or group of muscles has been weakened or paralysed by persistent over stretching.

Re-education of Muscles.

This is a term of which we have heard much in recent years, but it means nothing more than exercises carried out with a minute regard for the development of individual muscles. Enormous improvements have taken place in this branch of treatment recently as the result of medical men giving careful attention to the subject instead of leaving the cases to masseuses. W. Colin Mackenzie's⁶ name will always be associated with this work. Mackay⁷ recently published an excellent paper on infantile paralysis, from the point of view particularly of splinting and re-education. There is no doubt that active exercises are the best means of increasing the power of a weak muscle, provided that muscle has recovered sufficiently to contract voluntarily. Massage may improve nutrition, and more particularly check malnutrition, but it cannot cause a muscle to hypertrophy; alternate contraction and relaxation repeated over and over again can alone accomplish this. Normal voluntary contraction is always to be preferred, though electrical stimulation, when applicable, comes next in usefulness because it produces contraction.

A very important point always to keep in mind in the re-education of muscle is to make the load proportionate to the power of the muscle. It is worse than useless to try and make a partially recovered but very weak muscle produce a movement against the force of gravity. To put gravity out of court the limb is placed so that the muscles to be exercised move the part in a horizontal plane. To make it easier for this movement to be performed with the limb resting, the latter is often placed on a board sprinkled with powder to make it slippery. By this and other means the patient is induced to contract even the weakest muscles

over which he has any control. Fatigue is to be avoided at all costs, therefore constant skilled attention during the performance of exercises is essential.

Recovery can take place, particularly when the damage is slight, without any special treatment in the way of re-education, and this without deformity, provided splints have been employed, but without splints anything approaching perfection is impossible.

Massage should be continued with slightly greater vigour, but it is always well to keep in mind, as Sir Robert Jones⁸ has pointed out, that a paralysed muscle may be damaged by heavy manipulation. If a tendency to deformity in any one direction is present, the foot should be manipulated in the opposite direction so as to prevent the occurrence of contractures. This is a most important detail, and should be carried out morning and evening by the nurse or attendant. It is often asked after one, two, or more years have passed since the onset of the disease, "Is it any good going on with massage?" My reply is, "The more that limb is massaged, the more it is exercised, and the greater the care taken in keeping it warm, the less will it lag behind its fellow in growth, and the smaller will be the increase in the 'shortening' as the child grows up."

As regards electrical treatment, we must remember that there is a great deal of difference between a child with poliomyelitis and an adult with, say, a musculo-spiral paresis. In the latter it is easy to pick out individual muscles, and, moreover, the patient will readily stand the discomfort of the treatment, whereas in a child a stronger current is necessary to penetrate the relatively thicker layer of skin and fat overlying the shrunken muscles, so that a stimulus sufficient to cause contraction is too painful to be borne by the child; as Batten⁹ insisted, such a current usually causes contraction of the healthy opponents, and results in stretching rather than in active shortening of the muscles we are attempting to treat. In older children—and children vary considerably in how much they feel the faradic current—this method should be employed when practicable. In the majority of cases it will be found more worry than it is worth. This holds good for both the galvanic and the faradic currents. As regards other forms of electrical treatment, I must confess myself sceptical. Whether an electric bath with a uniform current passing through it does more than stimulate the skin I am very doubtful. As a means of diagnosis the faradic current is useful; it confirms our clinical diagnosis as to which muscles are really paralysed.

DEFORMITIES.

The causes of deformity are gravity and the inability of a weak or paralysed group of muscles to elongate their opponents after the latter have contracted. These two causes may work together or separately. A deformity becomes fixed, that is, incorrectible by ordinary manipulation, as the result of contracture of unparalysed or stronger muscles; after a time there will be in addition accommodative changes in the ligaments, bones, etc. Contracture of the muscle is due to the shrinking of the areolar fibrous tissue which binds the fasciculi together into an anatomical muscle. If this is not stretched in the normal way by contraction of opponents or by daily manipulations, it becomes permanently short and elongation is impossible.

It is, perhaps, not generally recognized that a totally paralysed muscle in poliomyelitis cannot become contracted, and that contracture of a muscle is proof of some, though perhaps not very obvious, recovery of tone in that muscle. As an example, equinus does not result when all the muscles below the knee are paralysed, even though the foot has been unsupported by a splint; in such a case flail ankle results. If any shortening of the tendo Achillis muscles is present there must be some return of power in the calf which should be capable of further development, though possibly not to the extent of being useful to the patient.

It sometimes happens that one muscle around a joint will recover sufficiently to be a strong factor towards the development of deformity, but being alone, or at the most having one adjacent muscle acting, it is impossible to make use of that power for the good of the patient. In other words, that muscle is a good deal more worry than it is worth. In such a case we may be driven to throwing the muscle out of action altogether by excision of a large piece of its tendon. The only other alternative is to transplant the tendon to a position where its power will be

harmless even if not particularly useful. As an example we may take the case of the biceps femoris surrounded by paralysed muscles and causing the triple deformity of flexion, valgum, and external rotation at the knee-joint. The tendon may be transferred to the front of the joint to take the place of the quadriceps, but I have yet to see the case where it has become an efficient extensor of the knee.

As already stated, operative treatment during the second stage should be confined to the correction of deformities; they are bound to get worse if untreated, and so long as they are present, muscles which may have a potential power of recovery are being ruined by overstretching.

The operative procedures are practically limited to tenotomies, fasciotomies, wrenching and tendon lengthenings. The latter is preferable in the bigger tendons; in the tendo Achillis, for instance, the Z method should be employed, and it matters little whether this is done by the open or the subcutaneous procedure. Sufficient lengthening of the tendon will be obtained, without undue elongation and resulting loss of power, if the tendon is allowed to unite with the foot at a right angle. I prefer the open method, particularly when the recovery is fairly evenly distributed in the muscles below the knee; it is more accurate, and the ends of the tendon can be sutured so as just to allow the foot to be brought to the right angle before the calf muscles are pulled on. The foot should then be dropped a little and held in this position for a few days, then gradually brought to a right angle and kept there. Walking should not be permitted for six weeks.

Having corrected deformities, the parts should be retained in the over-corrected position so as to relax as much as possible the weak muscles and stretch the strong, while re-education, massage, etc., are carried on vigorously.

Genu Valgum.

A not uncommon deformity at the knee, already referred to, due to the pull of the biceps muscle which has alone recovered, or has recovered to a greater extent than the rest of the muscles about the joint, is a triple one—a combination of genu valgum, flexion of the knee, and external rotation of the tibia. The biceps may or may not require lengthening, but in all cases correction must be gradual. I have found a jointed apparatus in which by means of a key the relative position of the two halves of the splint can be altered, of great service. Plaster is applied to the thigh and leg, the apparatus is adjusted to the same angle as the deformity, applied to the plaster, and more plaster bandages added to fix the thigh and leg pieces respectively. By means of the key daily improvement in the position of the joint can be brought about. Osteotomy is not required.

Splints.

For the foot I like a "tin shoe" which is made specially to meet the requirements of the particular deformity present. If the tendency is towards equino-varus, for instance, the sole plate should be above the right angle, should be everted, and should be curved, concave outwards, so that the foot when fixed to it will be in a position of calcaneo-valgus, with the fore part of the foot abducted. A quadrant and screw with a hinge at the ankle may be added when full correction is impossible at first, so that alterations in the splint may be made as the patient improves.

For the knee either a tin shoe with the calf-piece carried up to the buttock or a celluloid splint may be used.

In the hip we usually have to contend against flexion deformity; it is best dealt with by making the child sleep on a double inclined plane bed. This is easily made by putting a firm bolster cross-wise beneath the centre of the mattress. Towels and sandbags to keep the knees down will ensure a hyperextended position of the hip-joints, provided these joints are kept at the highest point of the bed. Jones points out that some internal rotation is necessary to ensure stretching of all tissues. If full extension of the joint is impossible, a sandbag may be placed across the lower end of the femur for an hour or two twice a day, while ordinary weight extension is applied to the leg.

For the arm the particular splint used must depend on the distribution of the paralysis, but in many cases the birth palsy splint shown or some modification of it will be found suitable.

For difficult cases, or where economy is necessary, although adequate supervision is available, removable

plaster of Paris shoes or other splints are useful. Celluloid, which was introduced in the treatment of these cases by the late Dr. Batten,¹⁰ is excellent for some cases, but I think there has been a tendency to use it in unsuitable cases. As usually made for the legs, celluloid splints are most inefficient as holders of the foot and preventers of deformity, though they answer admirably in cases of paralysis about the knee-joint. Personally I use them only in severe cases—that is, where the whole limb is paralysed more or less completely, and where the tendency to deformity of the foot must of necessity be comparatively weak. Experience teaches me that one or two points should be mentioned. Complete correction of deformity is essential before the use of these splints. It is not uncommon to see a celluloid splint made to fit a knee with a definite genu valgum. Secondly, in taking the model, plaster bandages must be carried right up to the top of the thigh or even further, and right to the tip of the toes; it is not uncommon to see the splint reaching only two-thirds of the way up the thigh and ending behind the ball of the foot. Thirdly, the foot must be at a right angle, and kept in this position during the whole of the period of the taking of the cast.

It is impossible to describe in detail walking apparatus for use by day, but a few points may be mentioned. One question that arises in every case with a tendency to drop-foot is whether a toe-elevating spring should be used or only a right angle "back-stop," which means that the joint opposite the ankle is so constructed that dorsiflexion is free, but plantar flexion cannot proceed beyond a right angle. I am inclined to favour the latter, for a spring is either so strong that the calf muscles cannot overcome it at all, and the patient walks on the heel, or the calf muscles are made unduly strong by having to overcome the pull of the spring. This is an undesirable result, as it is equilibrium between the opposing groups of muscles that we are so anxious to obtain.

In paralysis of the glutei muscles it is necessary to have an accumulator acting behind the hip-joint of the iron, to replace the paralysed muscles and retain the patient in an erect position. To get a firm attachment for the accumulator it is necessary to have a celluloid spinal jacket made, and it is also an advantage to have celluloid sheathing pieces for the thighs riveted to the "irons." The jacket can be cut away freely in front and be little more than a back plate, provided that there is no scoliosis.

THIRD STAGE.

We now have to consider the various problems which confront us when further recovery of muscle power is impossible.

Tendon Transplantation.

Orthopaedic surgeons are fairly well agreed upon the general principles which should govern the surgeon in carrying out tendon transplantation. An operation of this description should never be done until at least two years have elapsed since the onset of the disease, and never till any deformity present has been fully over-corrected. To shift a tendon and expect its muscle to correct deformity is bound to lead to disappointment. What we hope to achieve by tendon transplantation is to restore or increase the power of movement in a certain direction, to give stability to the part, and to check a tendency to deformity, and thus to make possible a reduction in the amount of apparatus worn by the patient. Sir Robert Jones,¹¹ to whom one naturally turns for help in this as in every branch of orthopaedic work, has insisted on the importance of selecting for transplantation tendons of which the muscles have shown definite evidence of very considerable recovery. Transplantation of a muscle which is only just acting is worse than useless.

The transplanted tendon should always be attached subperiosteally or even in a tunnel in the bone whenever this is possible, rather than simply sewn to another tendon. It is not advisable as a rule to shift the attachment of a tendon half way round the circumference of a limb; particularly is this so when the muscle has a pure action. For instance, good results are not usually obtained by trying to make a pure flexor into an extensor. An operation commonly practised is that of shifting the biceps femoris tendon and inserting it into the patella. I am open to conviction, but I have still to see such a shifted biceps contract alone at will, and produce extension of the

knee-joint. I have seen it contract with the flexors and interfere with the action of its fellows, but this is a very different thing from this muscle producing extension of the knee-joint at the will of the patient. On the other hand, the tibialis anticus is a dorsiflexor of the foot as well as an inverter, and when shifted to the outer side of the foot still acts as a dorsiflexor, and comes into action as such at the will of the patient, but its new attachment makes it combine dorsiflexion with eversion instead of inversion. In such a transplantation we do not rely on re-education of higher centres; hence the success which follows such an operation.

One of the most satisfactory transplantations is insertion of the extensor longus hallucis tendon into the head of the first metatarsal for those cases with a tendency for the ball of the big toe to drop, and for the big and other toes to cock up in the hammer position; more or less valgus is a common accompaniment; the tibialis anticus is usually paralysed, though not always. The line of action of the transplanted tendon is not appreciably altered, and being meant for an elevator of the fore part of the foot, it achieves this object with ease. There is one small addition to the operation as usually performed that I have found useful. The operation is followed by flexion of the terminal phalanx of the big toe, a condition which may be distinctly annoying to the patient, particularly when putting the foot into a boot. To avoid this, I sew the distal end of the extensor proprius tendon to the slip from the extensor brevis to the big toe, the terminal joint of the big toe being fully extended. The distal portion of this tendon now acts as a ligament, and prevents the dropping of the terminal phalanx.

Transplantations for paralysis of the upper limb are much less commonly performed. The war provided us with a useful experience in transplantations about the wrist-joint. In the forearm we have a very different problem from that encountered in the foot. In the hand and wrist deliberate, exact, and even fine movements are necessary, whereas in the foot mere stability is necessary, together with the gross movements of dorsiflexion and plantar flexion of the foot. Fortunately the synergic action of muscles about the wrist enables us to select tendons for transplantation which are normally called into action by forced contraction of the muscles which have become paralysed and which we wish to replace; as a result, anything in the way of re-education of higher centres, if this be possible at all, is not required. If the dressings are removed three weeks after operation, the desired movements of the fingers and the thumb can be performed readily, and with suitable treatment these movements rapidly become brisk and strong. Such a result unfortunately is not invariable, and for two reasons: either the muscles selected for operation are not the best, owing to an error of judgement on the part of the surgeon, or because the paralysis has limited the choice, or the technique of the operation is imperfect, the error usually being on the side of laxity of the transplanted and paralysed tendons.

This brings us to the important point of the strain that should be put on a transplanted tendon before it is attached to a bone or other tendon. There are two schools of thought on this subject: one says that the tension of the transplanted muscle should be no more than the normal tension of that muscle when the joint upon which it normally actuates is in the neutral position; whereas the other school says that the graft should be carried out with the tendons as tight as possible. When operating for the relief of peripheral nerve injuries, in which cases the muscles selected for transplantation are healthy, and have as a rule never been paralysed, there is no question that tightness of the tendons at the moment when the sutures are being inserted can alone give satisfactory results. In poliomyelitis, however, the problem is not quite the same; the muscle selected for grafting has almost certainly been paralysed at some time previously, and cannot therefore be expected to stand stretching in the way that a healthy adult muscle can. However, I am now transplanting tendons in cases of poliomyelitis with a much greater strain upon them than I did before the war, and I am convinced that the results are thereby improved.

One more point must be referred to, and that is the necessity for protecting the grafted muscle from undue strain for several months after the operation. This is

particularly necessary in the foot, where body weight and gravity play such important parts in the production of deformity. Exercises to develop power in the transplanted muscles should, of course, be carried out after sufficient time has elapsed for firm union of the transplanted tendon to occur at its new insertion.

ARTHRODESIS.

Arthrodesis should never be performed before about nine years of age, and gives better results if even further delayed.

In the shoulder there are two necessary conditions—fair power in the muscles fixing and moving the scapula, and sufficient recovery in the forearm and hand to warrant the operation. The elbow may be kept at a right angle by removal of skin from the front of it.

Arthrodesis of the hip-joint for poliomyelitis seems to me to be very rarely justifiable. The same may be said of the knee-joint. The chance of breaking the leg with the bones imperfectly developed, as they must be in a grossly paralysed limb, must be great; moreover, I think it only fair that the patient should be left to judge for himself whether he would sooner wear apparatus for the rest of his life and be able to bend his knee to sit down, or whether he would prefer a rigid straight leg.

In the ankle arthrodesis gives an excellent result in some cases, but not in all; the result apparently depends on the stability of the subastragaloid and other joints of the foot. If the mid-tarsal joint (Jones)¹² or the subastragaloid joints are fixed in addition, the results are much improved. Whitman's¹³ operation, which involves removal of the astragalus and shifting backwards of the foot so that the tibio-fibular mortice embraces the anterior end of the os calcis, gives excellent results in those almost completely paralysed legs. This is a particularly useful operation when calcaneus or calcaneo-valgus is present and tendon transplantation is impracticable or is considered insufficient by itself. The peronei, if acting, should be attached to the os calcis or tendo Achillis, as practised by Whitman.

The results of the insertion of silk to act as ligaments are, I think it may be fairly stated, very uncertain, and the improvement cannot be relied upon to last. As in every branch of surgery, particularly orthopaedic surgery, those who are keenest on, and employ to the greatest extent, a particular method of treatment are those who will get the best results therefrom; but my own experience of this method is that it cannot be relied upon to prevent a relapse of the deformity. The same may be said of tendon fixation, though I am not prepared to deny that both these methods may be of use when combined with tendon transplantation in selected cases. If a hole is bored through an atrophic bone—the tibia, for instance—and through it is passed a strand of silk, the opposite end of which is attached to a bone in the foot and the thread tightened, the weight of the foot, with or without the assistance of the calf muscles, will cause gradual absorption of the hole in the bone under the constant pressure of the silk, so that sooner or later the tightness of the thread eases off and the foot is no longer held in the desired position.

As regards the spine, poliomyelitis provides us with some of the most difficult cases to treat. As Lovett¹⁴ has pointed out, the deformity can begin while the patient is still in bed. In such cases I have found it advisable to use corrective slings pulling horizontally in opposite directions, made of towels or broad strips of flannel and tied to the sides of the bed. In the usual child's cot it is possible to apply these slings without compressing the chest and the abdomen by attaching the two ends of a sling to the upper and lower bars of the side rails respectively.

Tilting of the pelvis may be corrected by a perineal band pulling obliquely upwards on one side, while a weight extension on one leg pulls downwards on the other. Later a plaster bed, moulded to the patient in the slightly over-corrected position, if this position is possible, may be used for sleeping or resting in; while if walking is possible a celluloid jacket, holding the spine in the over-corrected position, may be used. Correction can also gradually be achieved by the use of a plaster bed with pieces of broad webbing stretched across so as to bring pressure to bear on certain spots—for example, the prominent ribs on the convex side of a curve, as first suggested, I believe, by Mr. Openshaw.¹⁵ I prefer to use felt pads in the floor of the bed to serve the same purpose.

In recent years, with the increase of bone grafting, particularly as the result of the pioneer work of Albee, grafts and other methods of bony fixation have been employed for the fixation and prevention of deformity of the spine in these cases. Unquestionably this is a justifiable procedure in selected cases, but many cases are not severe enough, while others are so severe and intractable, or are so hopelessly crippled generally, that the operation is unjustifiable. A case with obliquity of the pelvis and lumbar curve due to paralysis of the psoas or abdominal and lumbar muscles on one side, seems to me one in which operative fixation of the spine is worthy of serious consideration in the absence of any contraindications. Again, some severe "C" curves which are seen before fixation of the deformity to any great extent has occurred should also be treated by gradual correction as far as possible, with a view to eventual fixation by a bone graft. More is being done along these lines in America than in this country, by Albee¹⁶ and Mackenzie Forbes¹⁷ among others.

REFERENCES.

¹ *Acute Poliomyelitis*, Lumbleian Lectures, 1916, Bale, Sons and Danielsson, London. ² *Lancet*, May 3rd, 1915. ³ *Amer. Journ. of Diseases of Children*, December, 1911. ⁴ *BRITISH MEDICAL JOURNAL*, 1914, i, 1165. ⁵ *Ibid.*, 1918, i, 141. ⁶ *The Action of Muscles*, L. W. Lewis, London, 1918; *BRITISH MEDICAL JOURNAL*, 1917, i, 249; *Ibid.*, 1915, i, 60; *Aust. Med. Journ.*, June, 1911, and January, 1915. ⁷ *BRITISH MEDICAL JOURNAL*, 1920, ii, 513. ⁸ *Loc. cit.* ⁹ *Op. cit.*, p. 96. ¹⁰ *Lancet*, 1912, ii, 80, and 1914, ii, 216. ¹¹ *Loc. cit.* ¹² *Loc. cit.* ¹³ *Annals of Surgery*, 1908, ii, 64. ¹⁴ *The Treatment of Infantile Paralysis*, Heinemann, 1917, p. 57. ¹⁵ *Proc. Roy. Soc. Med. Clinical Section*, April 10th, 1908. ¹⁶ *Pennsylvania Med. Journ.*, 1915, xviii, 335. ¹⁷ *Journ. Orthop. Surg.*, June, 1920, ii, 6.

MITRAL STENOSIS, AURICULAR FIBRILLATION, AND THE ACTION OF DIGITALIS.

BY

C. H. CATTLE, M.D., F.R.C.P. LOND.,

HONORARY CONSULTING PHYSICIAN, NOTTINGHAM GENERAL HOSPITAL.

A WRITER in this JOURNAL¹ recently made the statement: "A clear conception of auricular fibrillation is essential to the management of heart disease." The commonest antecedents of this disorder are mitral stenosis and myocardial degeneration; it also occurs in connexion with arteriosclerosis, aortic and mitral incompetence, and certain acute diseases, as rheumatic fever, pneumonia, diphtheria, and infective endocarditis.

Whatever the cause of the fibrillation it can be most profitably studied in relation with mitral stenosis. If we wish to understand mitral stenosis, as we commonly see it in young adults, we must go back to the rheumatic heart affections of childhood. Our conceptions of rheumatism are apt to be dominated by the occurrence of arthritis. In adults arthritis is the prominent symptom; the heart affection is incidental. In children, on the other hand, the joint signs are often transient, insignificant, or absent, while carditis is very common. I use the word "carditis" advisedly, because pericarditis and endocarditis never occur without myocarditis. It is in children especially that this liability to pan-carditis exists. Murmurs and friction are well known and common signs, but the most striking sign of all, to my mind, indicating involvement of the myocardium, is the accelerated cardiac action which may continue for weeks or months following an attack of rheumatic fever or chorea. These cases need prolonged rest if the cardiac condition is to have time to quiet down. Valvular and muscular lesions are incurable, and the only chance of averting or mitigating their effects is to encourage resolution of the infective process by means of rest.

The structure of the rheumatic nodules on the valves and in the wall of the heart is similar to that of the subcutaneous fibrous nodules occasionally met with. The effect of the nodules on the valves may be rapidly destructive, causing, in the case of the mitral, more or less regurgitation; these cases may end in mitral stenosis from subsequent contraction of the fibrous ring to which the valve segments are attached. But a more common origin of stenosis is the presence in the valve of islets of infection, which lead to a chronic process of sclerosis extending over

years. Rheumatism is proverbially relapsing, and knowing its nature we can have no doubt that from time to time extensions of the infection in the heart take place, not necessarily accompanied by arthritis, but gradually leading to a tighter and tighter narrowing of the mitral orifice. Mitral stenosis is commoner in women than in men; chorea is commoner in girls than in boys. Acute observers like Barlow have suggested that the partiality of chorea for the female sex may to some extent explain the frequency of mitral stenosis in women. Chorea, like rheumatism, is notoriously apt to relapse; sometimes a murmur can be heard during an attack, sometimes not. I believe that most, if not all, cases of mitral stenosis are due to sclerosing valvulitis, whether choreic, rheumatic, or merely latent; its destructive effects are slow and insidious; the mitral curtains become thickened, indurated, and adherent at their margins, and it is not realized till years have elapsed that an irremediable narrowing has occurred. This sclerosing process may cause no alteration of the heart sounds till it has been at work a considerable time.

The symptoms and signs of mitral stenosis may be divided into (1) the incipient stage; (2) the stage of full development; (3) the stage of auricular fibrillation. In the first two stages the pulse is regular; in the last it is grossly irregular.

Mitral Stenosis: Early Signs.

The first stage causes no symptoms, hence it will not be recognized unless looked for. Children of known rheumatic history ought to have their hearts examined from time to time, especially at the time of choosing a career. Every patient ought to be examined both in the standing and the recumbent position; a presystolic murmur, not heard in the standing position, will sometimes be brought out if the patient does a little exercise and then lies down. An important early sign is an apparent reduplication of the second sound at the apex. It is not a true reduplication, as the second part of the sound is produced at the mitral and not at the semilunar valves. A real reduplication, heard at the base, is due to asynchronous closure of the sigmoid valves, but is of no importance as an early sign. An apparent doubling of the first sound at the apex may be due to a short and ill-developed presystolic murmur. An instructive case of this kind lately came before our special neurological board for army pensioners:

He was a man, aged 25, who complained of muscular pains and occasional swelling of the ankle-joints. I noticed slight, irregular, jerky movements of the right arm and leg, but as tremors and spasms are very common in this class of case, the significance of the symptom did not at first occur to me. In both standing and lying positions the heart's impulse was slightly forcible, though there was no obvious enlargement; the first sound was rather loud and accompanied by a systolic murmur; the second sound at the apex was reduplicated. At this moment one of my colleagues happened to come into the room and I asked him to confirm the signs. While he was listening he exclaimed: "Why, the man's got chorea!" and so he had plainly enough.

Here we had the three parts of the rheumatic picture pieced together—namely, the muscular and arthritic pains, the heart lesion, and the chorea. These early signs indicate heart disease of at least three years' standing, and the fully developed signs of mitral stenosis indicate disease of five or more years' standing. This man was working as a coal-miner, and illustrates the point of unsuitability of occupation. He was advised first to have treatment from his insurance doctor, and then to change his occupation if possible.

Intermittent and Later Signs.

The fully developed signs of mitral stenosis are so well known that I need only refer briefly to them. A presystolic thrill felt at the apex and terminating with the impulse is almost pathognomonic. The rough presystolic murmur of crescendo character, terminating in a short snapping first sound, and the accentuated pulmonary sound are well known and typical signs. It must be remembered that the murmur is heard over a very limited area—that is, the immediate neighbourhood of the apex; neglect of this fact has sometimes led to failure in diagnosis. The short first sound resembles the second sound in quality, and as the second sound often cannot be heard at the apex care must be taken not to mistake the presystolic murmur for a systolic one, and the first sound for the second. This mistake can be avoided by timing the

¹ A paper read before the Nottingham Medico-Chirurgical Society, February 16th, 1921.

² Review of *The Mechanism and Graphic Registration of the Heart-beat*. By Dr. T. Lewis. Vol. ii, 1920, p. 166.

murmur with the finger on the carotid pulse. The peculiar sharp first sound can often be heard several inches, even a foot or more, from the patient without the intervention of a stethoscope. The presystolic murmur may totally disappear, but the snap sound will probably remain. I went into the country lately to see a woman, aged 38, whom I had known for years as having a well-marked presystolic murmur. On this occasion the heart was regular and slightly rapid; there was neither murmur nor thrill, but the snap sound was definite and audible without contact with the patient at a distance of two inches. As the left auricle becomes dilated and hypertrophied and the stenosis narrows, the murmur often occupies the whole of the diastole, commencing with an accent shortly after the second sound, then diminishing, and again intensifying in the presystolic period. After auricular fibrillation has set in the diastolic portion of the murmur remains and the presystolic disappears.

This stage may last a varying number of years, the condition may appear to be stationary, and some people would say the valvular lesion was compensated. If the stenosis remain moderate life may be prolonged many years, but the tendency is for the narrowing to increase and for breakdown of one kind or another to occur. A large proportion of persons with mitral stenosis seldom feel well; they are soon fatigued and out of breath; there is generally slight cyanosis; they complain of cold extremities because the warming blood cannot reach these parts in sufficient quantity; they suffer from occasional epistaxis, from bronchitis, dyspepsia, and passive congestion of the viscera. My object is to follow out the effect of mitral stenosis on the heart, and only passing mention can be made of such accidental complications as haemoptysis, infarction of the lungs, embolism of cerebral or other arteries.

Auricular Fibrillation.

In a case of mitral stenosis the auricles may assume a condition of fibrillation in consequence of the natural progress of the disease, or of some sudden violent effort. The auricles have now lost the function of contraction by which they normally drive the blood into the ventricles. By fibrillation is meant an inco-ordinated, tremulous and flickering movement of the muscular wall of the auricles, which is in a state of continual agitation. If I may use an illustration of my own, I should compare the fibrillating auricles to the weak fibrillary twitchings which occur in the muscles of the body when they are undergoing paralysis and atrophy. In both cases weak and isolated contractions are taking place, and in neither case is there any resulting, purposive movement. The ventricles normally receive their contractile impulse from the auricles by means of the auriculo-ventricular bundle of fibres; the weak, rapid and irregular impulses arising in the auricles are reflected in the weak, rapid and irregular pulse—the well-known mitral pulse. This has been called “the perpetually irregular pulse,” since it remains irregular as long as the auricles continue to fibrillate. Most other forms of irregularity (for example, that due to premature beats) are either temporary or alternate with periods in which the pulse is regular. The fibrillations of the auricles may amount to as many as 500 a minute; the ventricular rate may be 120, 140, or even 200 in rare cases, so that it is obvious that many of the impulses fail to excite any ventricular contraction. It would not be correct to describe this condition as one of paralysis of the auricles. Indeed, if the auricles were paralysed and merely passive the heart would be better able to carry on its work. The ventricles are worried by the ceaseless stream of weak, rapid and irregular impulses proceeding from the auricles; their contractions are consequently irregular and inefficient, and their period of repose is shortened. This irregular action, combined with structural changes in the muscular wall, is a common cause of heart failure, as we see it manifested by dilatation of the heart, venous engorgement, passive congestion, and oedema. Many of the weak heart-beats cannot be felt by the finger on the pulse, and the only method of correctly ascertaining the real ventricular rate is by auscultation. This rule of auscultation applies to all forms of pulse irregularity, which by this means can often be differentiated from one another. The perpetually irregular pulse is in itself an important sign of auricular fibrillation, but there are also other signs in mitral stenosis

cases. The murmur loses its rasping character, becoming softer; it is often purely diastolic, not running up to the first sound when the pauses between the beats are long, but occupying the whole interval when the pauses are short. This diastolic murmur has been mistaken by competent observers for the murmur of aortic incompetence; Mackenzie, to whom we owe the foundation of our modern knowledge of heart disease, was the first to explain the true meaning of the murmur. The first sound often loses its sharp snap and becomes more of a tapping character. The onset of auricular fibrillation may in some cases cause but little discomfort; in others it may give rise to increasing cardiac failure from the first. Sir James Mackenzie states that he has seen many individuals with auricular fibrillation who have led strenuous lives, engaged in hard manual labour, and infers that in them the muscle of the ventricles had not been seriously damaged.

I have stated that in auricular fibrillation the ventricles beat rapidly and irregularly. This is true for the great majority of cases. Occasionally the contractions are slow and regular; this occurs when myocardial disease involves the auriculo-ventricular bundle, causing heart block, and thus interrupting the passage of impulses from auricle to ventricle.

Proof of the Occurrence of Auricular Fibrillation.

Mackenzie has said that “the discovery of this disorder is the most important yet made in the functional pathology of the heart.” Of the many hypotheses put forward to explain the perpetually irregular mitral pulse this is the only clear and unassailable interpretation. After Mackenzie had been engaged for some years in studying tracings from the venous pulse in the neck he noticed fine fibrillary waves in the tracing in certain cases where the wave caused by normal auricular contraction was absent. It is now known that these fine waves are caused by the fibrillating auricles. Dr. Thomas Lewis was the first to demonstrate the occurrence of fibrillation by pointing out the similarity between clinical electro-cardiograms, and similar records taken from animals in which fibrillation had been experimentally induced. Spontaneous fibrillation sometimes occurs in horses, and it was from observation on a horse that Dr. Lewis obtained final proof of the occurrence of this disorder. The animal was rendered unconscious, and in the exposed heart the fibrillating movements were clearly seen. It is thus obvious that the conception of fibrillation is no mere theory devised to explain the irregularity; but that the actual occurrence of this disorder has been definitely proved both by observation and experiment.

The Action of Digitalis.

It has long been known that digitalis slows the heart by prolonging diastole—that is, increasing the resting period. It is the discovery of fibrillation that gives the clue to the reason why digitalis acts so remarkably in some cases, and in others appears to fail. It has a twofold action, slowing the whole heart by stimulating the vagus nerve, and, by a specific influence on the auriculo-ventricular bundle, blocking some of the impulses proceeding from auricles to ventricles. It is thus clear why in many cases where the rhythm is normal and regular but little good results from digitalis, and that a great deal of the benefit derived in auricular fibrillation is due to the blocking of many of the disorderly impulses proceeding from the auricles. In this affection the heart is more susceptible to its influence, and there are times when it acts like a specific. It is more successful in rheumatic than in degenerative cases. Many cases of mitral stenosis, when the pulse is regular, do not require digitalis and are better without it. It should, however, be used whenever there is dilatation, except in acute febrile conditions. After irregularity has set in, whether in the early stages, or in the later ones characterized by oedema and other signs of heart failure, the results are often brilliant.

There are many ways of giving digitalis, but for ordinary purposes the *B.P.* tincture is reliable. It is said to lose its potency when dispensed with water, but I have not found this to be a common occurrence. In auricular fibrillation one drachm of the tincture—that is, mxx every four hours, or mxxv every six hours—should be given daily, carefully watching the effect by counting the pulse twice a day by auscultation. After four or five days the heart's rate will begin to fall; in another day or two it will be

between 70 and 80, and then the drug must be left off for a few days. When the heart's beats occur in couples, as is sometimes the case, the drug should be immediately omitted for a few days. Other signs of sufficiency are severe headache, nausea, vomiting, and diarrhoea. Any of these call for suspension of the drug. After a physiological reaction of this description has been obtained, an attempt should be made to find the daily quantity of digitalis which will keep the heart about the normal rate. Patients can take small tonic doses for months without bad effect if they are instructed to omit the medicine for a few days occasionally. The patient's sensations are a good guide as to whether more or less of the drug is required, and some feel best when the heart's rate is kept as low as 50.

In heart failure from purely degenerative changes, in which the pulse frequently remains quite regular, the effects of digitalis are not so good. In these conditions digitalis should be given in the same doses with the same precautions as I have already advised. Mackenzie states³ that he has many times attempted to reduce the increased rate of the heart when the rhythm was normal, and invariably failed. This observation certainly applies to all febrile and toxic states. Here the heart muscle is poisoned by the bacillary or other toxin, and digitalis can have no good effect while this condition remains. It may be useful for the resulting heart weakness after elimination of the toxin. Sutherland⁴ obtained reduction of the pulse rate after the temperature had subsided in rheumatic fever. Speaking generally, more good may be anticipated when digitalis slows the heart's action; a longer period of repose is followed by a stronger beat. Cases have been reported in which good resulted although no reduction in rate was obtained.

For pulse irregularities due to premature beats, which commonly cause intermission of the pulse, digitalis should not be given. The drug itself will occasion premature beats, and would certainly aggravate the condition where the tendency already exists. It is not a safe conclusion that because a heart intermits occasionally it is necessarily a weak heart. Digitalis is often wrongly given for supposed "weak heart." Our ideas are certainly clearer than they were ten years ago as to the cases digitalis is likely to relieve and those which it is not.

The paper was illustrated by lantern slides. For some of the subjects I am indebted to Sir James Mackenzie, Dr. Lewis, Dr. Price, and Messrs. Shaw and Sons.

BIBLIOGRAPHY.

- Allbutt's *System of Medicine*, vol. vi, 1909.
 Brahmam: Auricular Fibrillation, *Lancet*, February 19th, 1921.
 Broadbent: *Heart Disease*, 1900.
 Lewis: *Clinical Disorders of the Heart Beat*, 1912. *Mechanism of the Heart Beat*, 1920. *The Soldier's Heart*, 1918.
 Mackenzie: *Diseases of the Heart*, 1915. On Digitalis, *Heart*, 1910-11; and other papers.
 Roynton: The Nature and Symptoms of Cardiac Infection in Childhood, *BRITISH MEDICAL JOURNAL*, 1918. On the Study of Heart Disease, *Ibid.*, vol. ii, 1920. Acute Rheumatism in Children, *Lancet*, vol. ii, 1920.
 Price: *Diseases of the Heart*.

THE TREATMENT OF SCIATICA BY GALVANIC ACUPUNCTURE.

BY

E. A. GOULDEN, M.D.,
LLANDRINDOD WELLS.

The treatment of sciatica may be comparatively simple or very troublesome. Some mild cases, with rest in bed and sedatives, recover, but in others the whole Pharmacopoeia has no effect, for no known drug has any effect on neuritis or on the absorption of the exudation. Neuritis is usually divided into two types—the parenchymatous and interstitial—no local treatment can have any effect on the former; it is with the interstitial type associated with inflammatory changes in the sheath and connective tissue, and accompanied by exudation of cells, that we are concerned. There is reason for believing that this exudation is distributed not continuously along a nerve but in patches revealed by tender areas or by use of the faradic current. Treatment by acupuncture is particularly serviceable in these cases of nodular fibrositis.

Dr. Davis, formerly of Llandrindod Wells, first introduced and described this method in the *Bristol Medico-Chirurgical Journal* in June 1915, but it has been in use for twenty years in hundreds of cases of sciatica and other forms of neuritis.

It is not my intention here to enumerate the different causes of sciatica. I exclude all cases due to pelvic growth, bone disease, spinal cord disease (as locomotor ataxia), diabetes, venereal disease, etc. These have their own special form of treatment, and must be managed on constitutional lines. A definite diagnosis is as important in the treatment of sciatica as in any other ailment, for local treatment of sciatica when there is grave constitutional disturbance is bound to end in failure.

The aim of all the various forms of treatment devised for sciatica is to induce hyperaemia of the nerve. In the Scotch douche and radiant heat an endeavour is made to secure this by the varying stimuli of hot and cold water, or by exposing the whole limb to high temperature. A general hyperaemia of the skin and underlying tissues of the whole of the lower extremity may be obtained, but there is no guarantee that the nerve shares in this hyperaemia—often it does not; at any rate the method is empirical.

By acupuncture the hyperaemia occurs just where it is required, and it can be given in definite doses varying according to the response of the nerve. Again, when an electric current is passed through the tissues sodium hydrate is formed at the negative electrode, which in this case is the needle passed down to the tender spot on the nerve. This sodium hydrate has a caustic action on the tissues. In acupuncture only a small amount of current is used (5 to 6 milliampères) whereas in destruction of a naevus 20 milliampères or more are used. In the case of the naevus a large area has to be destroyed, but in the case of exudation in the nerve sheath the area is very small and the effect should be limited to the exudation. The effect of ionic movement in the tissues is involved also.

From one or all of the above effects it is maintained that by this treatment there is complete relief of pain, but the wasting of muscles with weakness of limb and lameness requires appropriate treatment.

Electrical acupuncture, if carried out according to instructions, is harmless. It must not, of course, be used recklessly with any strength of current, nor must the needle be plunged into any part of the body without consideration of the underlying parts.

Method of Application.

The equipment necessary is:

1. Pantostat or other universal apparatus.
2. Insulated needles of various lengths with platinum points.
3. Holder for needles.
4. Button electrode.
5. Hypodermic syringe and 2 per cent. solution of novocain.
6. Sterilizer.

The sensitive spots along the course of the nerve must be found by means of the faradic current and each one separately treated. An indifferent electrode attached to the positive pole of the faradic current is placed below the knee or on the back. The negative pole is attached to a moistened wash-leather button electrode mounted on a handle.

The buttock is first tested; after turning on the current until the patient just feels it, the button is moved over the surface of the skin until a sensitive spot is touched; this is marked. Two or more of these spots may be found, and the most sensitive is first treated. The easiest way to find the most painful spot is to reduce the current until one or other of the spots is not felt. In neurotic cases it is a good plan to approach the spots from different areas to be quite sure it is properly localized.

The galvanic current is now used. An insulated needle, about 4 in. long, sterilized and attached to a holder, is connected up to the negative pole. The same indifferent electrode is used, now transferred to galvanic current instead of faradic. The skin over the area is painted with iodine and anesthetized with novocain (2 per cent.). The needle is applied to the chosen spot and the current quietly turned on. I usually begin with about 2 milliampères. The needle is now passed through the skin and deeper tissues and more current applied. It is necessary for the patient to feel something, but it is unnecessary to produce pain. Good results can be obtained in some cases by using 2 milliampères; in other cases 5 or 6 milliampères may be required. If the patient complains of pain, then the strength

* BRITISH MEDICAL JOURNAL, January 29th, 1921, p. 152.

† *Ibid.*, vol. ii, 1919, p. 50.

of current must be reduced. A reliable guide as to when the needle is in the right place is that the patient states that he experiences the same kind of pain as that of which he complains; the position is then correct and the treatment continued for ten minutes. If not found at first, then the needle must be moved about under the skin until it is. During this ten minutes it may be necessary to increase or diminish the current according to the patient's sensations. After the current has been passing a few minutes the pain often diminishes and the current can be increased. After ten minutes the current is slowly turned off, the needle removed, and the puncture sealed with collodion. No after-treatment is necessary. The spots are treated on alternate days.

It is not possible to say beforehand what strength of current may be required, but the treatment should not be painful. If too much current is used, then considerable pain may be produced and a great deal of reaction follow; the more tender the spot, the less the current. The nerves in different parts of the body vary considerably in the amount of current they take; thus, the nerves of the scalp readily take up to 5 or 6 milliampères and the sciatic and its branches are nearly as tolerant.

The number of spots to be treated in any given case of sciatica varies. There may be only one or two or there may be as many as seven, eight, or nine. The average is about five, but no case must be considered cured until every spot has been treated. This must be done systematically, beginning with the buttock and

following down the thigh, front or back, according to the distribution of the pain. Pain around the knee-joint is often troublesome, and spots for this are found about 3 or 4 inches above the patella on one or both sides of the quadriceps extensor tendon. For the pain below the knee, spots are sought for in the calf or front of the leg, also in the latter area for sensory disturbances over the dorsum of the foot.

Acupuncture will not cure the wasting that frequently accompanies long-standing sciatica, and it is important to warn patients of this. The treatment is introduced solely for the relief of pain. For the lameness, and wasting of muscles, the patient must be taught to walk correctly, and massage and electricity are used.

All the failures I have had have been in cases of very long standing in which probably the exudation has become organized or the nerve has been damaged by pressure beyond recovery. It is not possible to recognize these cases beforehand, for many cases of very long standing recover; one case I recall was that of a man of 50, who obtained complete relief of pain, although the nerve was so damaged that his patellar reflex on that side was absent.

The line of treatment described is applicable to any other accessible nerve with suitable modifications. The sciatic nerve is taken as an illustration only; equally successful results can be obtained in any other part of the body.

LIGHT METAL LIMBS IN ABOVE-KNEE AMPUTATIONS.

BY

EDRED M. CORNER, M.C., F.R.C.S.,

MAJOR R.A.M.C.(T.F.),

SURGEON TO ST. THOMAS'S HOSPITAL; CONSULTING SURGEON, QUEEN MARY'S AUXILIARY HOSPITAL, ROEHAMPTON.

The wooden walls of Old England in their day did excellent service; they were replaced by metal because of its greater efficiency. So it will be with wooden limbs; they will only exist for particular purposes. Among artificial arms that made of duralumin for lightness more than holds its own. For amputations of the thigh above the

knee lightness of the artificial limb is essential, for the muscles of the stump are parallel with the bone, and the other muscles which activate it, the ilio-psoas and the glutei, are attached to the end of the femur. Hence the longer the thigh stump the greater the leverage against these muscles, and the shorter the thigh stump the less the leverage. The medium length thigh stumps, 8 to 9 in., are best off. This is seen from Fig. 1. Above this point the gluteal group of muscles begin to abduct the bone, making the man walk badly, often with lurching and the circumduction associated with progression on a peg leg (Fig. 2). This comes on progressively as the muscles are strengthened by exercise and after the fitting of the first limb. These are the two chief points in the mechanism of an artificial limb for the thigh



FIG. 1.—With the amputation at 1 there is little bony leverage to help the muscles. With the amputation at 3 there is much bony leverage against the muscles (like a high-g geared machine going uphill). With the amputation at 2 the above two factors are more nearly balanced and the patient is best off.

—leverage and abduction.

At a discussion on the subject of re-education of the limbless, admirably introduced by Mr. Muirhead Little, at the Medical Society in March, 1920, the President, Mr. Warren Low, referred to the mental and moral deteriorations which follow the loss of a limb. These are sometimes great and sometimes small, but almost always present in some degree. The nearer to the trunk the amputation is, the greater would seem to be the change. This change is accentuated by the man's temperament and surroundings, being the greater with the larger mentality. To weight and handicap men who have gone through much with a limb which feels "too heavy" and,

though their capabilities may be great, exhausts them, is wrong. It is not clear whether these conditions result from the degenerative changes which occur in the central nervous system in association with the loss of the educative value of the limb. To remedy this the amputated man requires the lightest limb, a minimum of hospital life, and a rapid return to work and bright surroundings. At present this can only be obtained by the use of a light metal limb with quick fit, quick instruction and after-care. At present all these factors are lacking. Metal is chosen because in light limbs of wood the wood is so thin that it cracks and constant repairs militate against the original cheapness of the limb. A well-made metal limb needs a minimum of repairs, and thereby soon repays the initial outlay.

Owing to assistance given by the Red Cross and Sir Arthur Stanley, and to the kindness of Colonel Sir Lisle Webb and Sir Charles Kenderdine of the Ministry of Pensions, it has been possible to make experiments at St. Thomas's Hospital on these lines, and it is desirable that the results should be made as widely known as possible, since they bear out in practice all that has been prefaced in theory, and offer considerable hope of improvement to 90-95 per cent. of cases of amputation of the thigh. They are based upon observations made on over one hundred light metal limbs. The results of my experiences are shown in the following extracts.

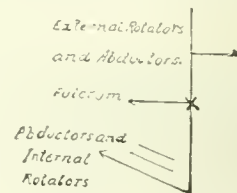

FIG. 2.—As the amputation is done higher and higher up the femur more and more adductors and internal rotators are cut off. The adductors and external rotators are strengthened by the exercise of wearing the artificial limb, and hence its non-fit after a few months' wear. This is more felt by those men of greater mentality. It occurs in the use of both wood and metal limbs and is often shown by the roll of flesh on the inner side of the bucket top.

Reports to Sir Arthur Stanley.

The first point to come out was that, although the (metal) artificial limb gave the amputé satisfaction, the metal limb was only a few ounces lighter than specially constructed wooden limbs. The satisfaction could hardly, then, be in the weight. (Light wooden limbs weigh about 5½ lb.; light metal ones 4½ to 5¼ lb.) About 90 to 95 per cent. of men suffering from above-knee amputations are greatly benefited by these limbs.

- (a) The universal statement is that they can do more work with a fraction of the fatigue.
- (b) Men supplied with light metal limbs can learn quicker and more than can men with wooden limbs.

- (c) The special light wooden limbs supplied by the Ministry of Pensions are a distinct improvement on the older type, but break and split more quickly, having reached the limits of what wood is capable. The hybrid limb of wood and metal supplied by the Ministry bids fair to be satisfactory. But it is too early to say much about it.
- (d) When conscription was introduced into the army all kinds of men were taken into it and some lost their legs. There is no doubt that men fitted with light metal limbs are happier, more useful men, who more easily learn and amongst whom there is a more generally high percentage of physical fitness than there is amongst the wearers of the wooden limbs. They cannot make C3 men A1 men!

Light metal limbs should not at present be given to all, but those to whom they are *not* given should be carefully selected. At least two refused to exchange their wooden limb for a metal one. At least one who has had a light metal limb prefers his wooden one. (He is stated to have had inadequate length of instruction.) Apparently the heavier wooden limbs are more apt to cause pain and necessitate operations than light metal ones, especially when the fit is imperfect.

Apparently the repairs necessary in metal artificial limbs are less frequent—but more difficult and costly—than they are in wooden limbs. This would be lessened in manufacture on a larger scale and would help to compensate for the larger initial outlay.

It is at present doubtful if there is advantage in having the artificial limb less than 4 to 5 lb. in weight, as the lighter the limb the more uncontrollable it becomes. This is not the theoretical statement it is often said to be.

It should be added that one insufficiently instructed man for urgent reasons was allowed to take away a metal limb in the rough, and it gave him so much trouble that he inquired of the Ministry who was responsible for its repairs. Both man and limb were half-fledged.

So much for the theory, the practice, and the immediate results. To ascertain the later results all officers were written to and replies were obtained from a large number. These replies have shown four chief points:

1. Those who had been given and had done well on a heavier wooden limb did most obviously better with metal. They had already shown that they could help themselves, and, supplied with lighter limbs, could do more.
2. A light metal limb should be fitted first of all, so avoiding the delay and learning to use the heavier wooden limb.
3. All men who had previously got about on a heavier wooden limb were for varying times "at sea" with the light metal one before they settled down to steady improvement.
4. The heavier wooden limbs caused far more trouble in painful breaking down and difficult stumps than did light metal ones.

In connexion with 4 it is necessary to say something about the pathology of the stump. The keynote to all the pathology of stumps that are painful and easily break down is the presence of infective inflammation in the tissues. All tissues can be affected. We can see the results in skiagraphs in new-formed bone, and if infective inflammation is found to be present in the bone its presence may be inferred in other structures—nerves, for example. In an amputation nerves must be divided, and being divided they must regenerate. In regenerating it has been shown that they carry down with them the infective inflammation in them, re-infecting and making painful a perhaps merely uneasy stump and producing the late onset of pain. Dr. Urquhart helped much in the bacteriology of these stumps and Colonel Sir Archibald Reid in the skiagraphs. The importance of skiagraphing many stumps that have worn one of the heavier wooden limbs before ordering a second is apparent. Skiagraphy is, in fact, one of the most valuable means there is of examining a stump.

In the concluding part of this paper I will quote what three of these officers say for themselves. There are many more replies which show—

1. That at times the light metal limb is badly made and fitted, requiring repairs (even then less so than wood).
2. Light metal limbs are an inestimable boon to many of those who have had thigh amputations.

CASE I.—II.

Daily Work.—The increased ease with which one gets through one's daily work is maintained.

General Condition.—Continues improved.

Athletic Value.—I am markedly able to get about with greater comfort and speed. I have recently been able to take part in boating, fishing, and shooting, all of which entailed considerable activity, and I was pleased with the way in which the light leg responded.

Stiff Ankle.—This slight obstruction is wearing off, and I hardly notice it as a hindrance now. It is preferable to a movable ankle, saves weight, and gives a bit of a spring off the foot.

CASE II.—I.

I am quite delighted with my light metal limb, and am much better in every respect. You will remember how my stump continually broke down with my heavier wooden, now I can say I have completely got over all that trouble, which has been a constant source of worry to me. I am getting about much better now, and do not know what it is like to be exhausted. This had a great effect on me generally. My health has improved and my work is more of a pleasure and consequently better, and I am hoping to take up tennis again this summer.

In the early days—I mean 1915-16—when the heavier wooden legs were good and well made, I had a comfortable leg, and got on extremely well and was satisfied as far as heavy legs were concerned, but I must say, with my short experience of a light leg, I wish I had gone in for one at first. It would have saved me a tremendous lot. I am quite convinced that light legs are the thing. I could do most things on a wooden one—dance, tennis, climb about rocks, etc., but at what an expense of energy, and I did too much and got overtired.

This officer hits the nail on the head by writing: "The whole secret of the light leg is the conservation of energy, and when one is exhausted one's brain is exhausted as well."

CASE III.—A.

I have had the light metal limb now for over four weeks, and cannot praise it too highly. Candidly, I never before imagined that an artificial limb could be so useful. My first leg was a wooden one, and, in fairness to Messrs. —, I liked their limb and its movement, and did very well with it.

As regards distance walking, one evening in London I walked on my wooden leg just over five miles—a good distance on a limb weighing over 9 lb. (including shoe), but during the last two miles I was decidedly tired and found my foot scraping the ground very often. With my metal limb I have not tried a long distance walk, but feel sure that this distance could be doubled with less fatigue. A brief outline of my day's work will support this. I walk to the office in the morning (one mile). From 9.30 till 5.30 I am on my feet practically all the time; walk home in the evening, and very often later on I walk again perhaps for two, three, or four miles before bedtime. This does not fatigue me in the very least, and I come home feeling I have enjoyed an outing and could have done miles more.

As regards walking quickly I could do this on my wooden limb, but there was a great strain on the shoulders as the knee was controlled therefrom. The metal one has no shoulder control, and to my mind this is not necessary, as by a slight extra jerk of the stump forward speed can be increased at will. Timing myself in the ward when I had my light metal limb in the rough, I found that I did 136 paces to the minute, which, as infantrymen will know, is a very quick march. Walking uphill with the light leg differs very little from walking on the level. With the heavy leg there is a great difference, and it is very fatiguing and slow work. As regards loss of control in strong wind, in my experience the heavy limb is affected to the same degree as the light, and loss of control varies with length of stump. Personally I have had no trouble and have been in some very strong winds during the last few weeks.

To sum up, I think the light metal limb is far and away superior to the heavy, and I consider myself fortunate in possessing one; and I hope the time will come when I can forget that my heavy limb ever existed.

Light metal limbs having succeeded so well in some 90 to 95 per cent. of thigh amputations it was reasonable to try them on below-knee amputations, and this has now been done successfully. The percentage of those improved will be smaller, and it is possible that a better artificial limb may be made for a Syme amputation. It may be to the advantage of the amputated man to have a hybrid limb (wooden socket and metal shin, as tried by the Ministry; at present it is too early to say, but as most serious repairs are required to the sockets it may be doubted if wood should be used there).

He was sent on from Dover House to St. Thomas's because of this.

At a meeting, on April 1st, of the West London Medico-Chirurgical Society, with the President, Dr. F. J. McCann, in the chair, a discussion took place on the diagnosis and treatment of colitis, in which were emphasized the importance of sigmoidoscopic examination, the influence of diet as a cause and in the treatment of the condition, bacteriological examination of the faeces and treatment by vaccines, and the influence of climate. Previous to this discussion a number of clinical cases were shown by Mr. Aslett Baldwin, Mr. B. Sangster Summonds, Mr. Neil Sinclair, Dr. W. N. Goldsmith, Dr. Clifford Ellingworth, and Dr. W. R. Marshall.

THE PRESSURE IN THE RENAL, PORTAL AND GLOMERULAR CAPILLARIES OF THE FROG'S KIDNEY.

BY
LEONARD HILL, M.B., F.R.S.

(From the National Institute for Medical Research.)

(Preliminary Note.)

By making an incision through the skin and abdominal wall in the lumbar region of a urethanized frog and removing the ileum on the same side the kidney is exposed. The cantery is used to stop all haemorrhage. A ligature is tied round the membrane attached to the outer edge of the kidney. By very gentle traction the kidney is then drawn on to the transparent peritoneal membrane which covers a small brass chamber with a glass floor, similar to that used by Roy and Graham Brown in their measurement of capillary pressure in the frog's web. A glass cover is then brought down on to the upper surface of the kidney so that it can be squeezed between the membrane and glass cover when air is blown into the chamber. A water manometer indicates the pressure used for compression. The kidney is examined under the microscope, using a magnification of one hundred times. The kidney appears closely covered with a network of branches of the renal portal vein, through which blood flows slowly in copious streams. On compressing with a pressure of about 2 centimetres of water these vessels are squeezed empty, and the tubules and, in successful preparations, the glomeruli then come into view; the arterial blood is seen rapidly circulating through the glomeruli. The Bowman capsules can be seen surrounding some of the glomeruli, and the glomeruli hanging in a clear space within these. In some glomeruli the afferent and efferent vessels are clearly seen, and the blood corpuscles can be watched racing through the afferent vessel, whirling round the twisted capillaries of the glomerulus and out through the efferent vessel. On the inner edge in one preparation a row of glomeruli were seen fed by the branches of one of the renal arteries.

The pressure required to stop the renal artery and the flow in the glomeruli is of the same order as that in the arteries of the web of the frog's foot—for example, when there has been little loss of blood and the circulation is vigorous, 30 to 40 cm. of water. A pressure of 7 to 9 cm. of water in this case sufficed to modify the flow in the glomerular capillaries, making it a little slower. By increasing the compression the corpuscles in the glomeruli could be driven out, the flow reversing through the afferent vessel. In a kidney in which the blood flow had stopped a pressure of 7 cm. of water sufficed to squeeze blood from the larger vessels through the glomeruli and produce a rapid flow. This preparation of the living frog's kidney seems likely to afford a valuable additional means of studying the renal secretion under various conditions.

A CASE OF COMPLETE PNEUMOTHORAX IN AN INFANT, DUE TO PULMONARY TUBERCULOSIS.

BY
GEOFFREY BOURNE, M.D.,

PHYSICIAN TO THE EAST LONDON HOSPITAL FOR CHILDREN,
SHADWELL.

This case is published for two reasons: First, the condition is extremely uncommon. Secondly, some light is shed as to the probable mode of transmission of the tubercle bacillus to the lungs in childhood in certain cases of pulmonary tuberculosis.

The patient, a boy aged 18 months, was admitted with cyanosis, cough, and dyspnoea, to the wards of the East London Hospital on May 11th, 1920. The history was that he had been in his usual health until three months before, when he contracted measles. Since then he had been in poor health, the chief symptoms being lack of appetite, constipation, wasting, and slight cough. For the last three weeks the cough was decidedly worse; food had frequently been vomited in association with it. The

acuteness of symptoms during this latter period had been distinctly accentuated. He had become bluer during the last few days.

Condition on Examination.

On admission the temperature was 102 F., the pulse rate 142, and the respiration rate 40. The child appeared to be extremely ill. Cyanosis was very marked, being especially obvious in the lips and finger-nails.

Examination of the chest gave the following physical signs: Respiratory movement was slightly diminished on the left side, the intercostal spaces on this side appeared to be fuller. Cardiac movements were visible in the fourth space to the right of the sternum. Cytometric examination showed the left side of the chest to be the larger by a quarter of an inch. By percussion the heart was found to be displaced two inches to the right. The whole of the left side was hyper-resonant. Over the right side the note was less resonant than normal, the impairment was particularly intense at the right base and less so in the right axilla. The respiratory murmur was very much diminished all over the left side, both back and front. Expiration was prolonged over the right lung in front; in the right axilla the breath sounds were bronchovesicular. Numerous fine râles were present over the right lung, back and front, especially at the base. No cardiac murmurs were heard.

The liver and spleen were both easily palpable, otherwise no abnormality was discovered in the abdomen. Clubbing of the fingers was not present.

A condition of complete pneumothorax of the left side, associated with bronchopneumonia of the right lung, was diagnosed.

The temperature fell to 98°, the pulse rate rose to 180, and the respiration rate to 70, within the next twelve hours, and the child died.

Post-mortem Examination.

The child appeared to be well nourished. Cyanosis was extreme; the nails of the hands and feet were light blue in colour. Hypostasis was well marked. The brain was congested, and the subarachnoid in the basal region had a milky appearance; no gross tubercles, however, were seen.

Thorax.—The heart was normal. No pericardial tubercles were found. The left lung was collapsed down upon its root, except at the apex, where it remained adherent to the parietal pleura. The left parietal pleura was studded with miliary tubercles; none were seen on the right side. No excess of pleural fluid was found. The left lung was a solid mass of yellow tubercles. It sank in water. At the apex, where it was adherent to the pleura, a cavity the size of a hazel nut was present. The walls of this were formed by greyish ragged granulation tissue; it was surrounded by an area of extreme caseous change, and its interior communicated by means of a small rent with the left pleural cavity. The right lung was not solid, except in a few small areas. It contained many miliary tubercles. The glands at the hilum of both lungs were slightly enlarged, hyperæmic, but definitely not caseous anywhere.

Abdomen.—No free fluid was present. The liver was seen three inches below the costal margin, and the spleen was also visible. Both were studded with miliary tubercles. Section of the liver showed the presence in its substance of miliary tubercles, some of which were bile-stained. The spleen was adherent to the tender surface of the diaphragm; it, too, had many miliary tubercles within it. Both kidneys showed subcapsular tubercles. A few subperitoneal tubercles were found on the walls of the small intestine. The testes were normal. The parietal peritoneum had escaped except where it came into contact with the hepatic and splenic surfaces.

The right knee-joint was normal.

Bibliography.

Cruchet¹ states that of the causes of pneumothorax in children tuberculosis is the least common. He quotes, in addition to his own experience, Lenz, who found tuberculosis in 40 per cent. of his fourteen cases, and Chrysanowska, whose figure is 38 per cent. of twelve cases. He states that in the tuberculous cases tuberculous bronchopneumonia was the commonest cause, but that the opening

into the pleural cavity was very rarely observed. Further that the base of the lung was the commonest site of the lesion.

Bovaird² collected 18 cases, 4 of which recovered. Particulars of 12 of these cases are available; 5 were associated with bronchopneumonia, and 4 of these with measles in addition; 2 with miliary tuberculosis; 2 with diphtheria and emphysema; 2 with pulmonary abscess; 1 with trauma.

I have found in the literature no other case of complete pneumothorax due to tuberculosis in a child of 18 months.

Pathology.

The probable course run by the disease in the case under survey is well marked out by the *post-mortem* findings. The oldest tuberculous focus found was the collection of very large mesenteric glands, the most recent was represented by the general miliary tuberculosis. Another point shedding great light on the direction of spread was that the left pleural cavity—the one corresponding to the lesion of the pneumothorax—was studded with miliary tubercles, whereas the right cavity was entirely free from them.

The tuberculous disease of the left apex, although fairly recent, was probably of considerably shorter duration than that present in the mesentery, for no caseation was found in the hilum glands of either lung, and the extent of the apical lesion was less than a square inch.

The following reconstruction of the spread of the disease is here tendered:

The exciting cause of active tuberculosis was the attack of measles, and the primary focus of disease was the mesenteric glands. From this origin tubercle bacilli reached the blood stream by way of the abdominal lymphatics, and were carried through the right side of the heart, eventually reaching among other places the apex of the left lung. Those that reached this position flourished and ultimately produced a rapidly caseating area whose territories spread till the left pleural surface was reached. Adhesions were formed here below the two layers of the pleura. During some violent effort of coughing the portion of diseased tissue between a bronchus and the left pleural cavity gave way. The history places this occurrence at three weeks before death. The pleura was severely infected with tuberculous material and became studded with miliary tubercles. As the direct result of this sudden massive infection of a serous surface generalized miliary tuberculosis arose and provided the final scene.

The absence of disease of the pulmonary hilum glands is interesting in view of Canti's observations³ upon the pulmonary lesions of tuberculosis in children, which suggest that the lung is frequently affected before the glands at its hilum. It seems clear, however, that in this case infection was alimentary and haematogenous, not inspiratory. Unfortunately cultures were not made to prove the class, whether human or bovine, to which the organism present belonged.

REFERENCES.

¹Cruchet, La pneumothorax tuberculeuse chez l'enfant. *Cong. intern. de la tuberc.*, Paris, 1905, ii, 238. ²Bovaird, Pneumothorax in children. *Arch. Ped.*, New York, 1933. ³Canti, *Quart. Journ. Med.*, vol. xiii, Oct., 1919.

Memoranda:

MEDICAL, SURGICAL, OBSTETRICAL.

MELAENA NEONATORUM TREATED BY BLOOD TRANSFUSION.

On February 12th, 1921, I delivered a primipara of an apparently healthy female child weighing 6 lb. During the night the child vomited dark fluid and passed what I supposed to be meconium three times. On the following day the child was very restless and cried considerably. The bowels acted once, the motion still being like meconium. At 1.30 a.m. on February 14th, the baby vomited dark blood, and shortly afterwards passed a large quantity of black, foul-smelling blood from the bowel. Fluids given by the mouth were vomited immediately, and the child appeared to be very ill. At intervals of about two hours alarming quantities of blood were passed from the bowel, and at the same time the child had all the symptoms of a severe haemorrhage; the skin and lips were almost white,

the heart beats were too rapid and weak to count, the respirations were sighing, and the eyes half-closed. From the symptoms I concluded that the child would die shortly unless blood transfusion could be performed.

As I myself belong to Group IV (universal donors), I drew from a vein in my left arm 20 c.cm. of blood with an exploring syringe into which I had already drawn 5 grains of sodium citrate in sterile solution. I then exposed a vein in the baby's arm by an incision, and exchanging the large exploring needle of the syringe for a fine hypodermic needle injected the blood into the vein of the baby. It was a matter of extreme difficulty to strike the lumen of so small a vein in a collapsed condition, but I was fortunate in injecting the blood without wasting any. The improvement in the child was immediate and striking. The colour returned to the lips, the respirations slowed down, and the pulse at the groin became palpable. During the next twenty-four hours the bowels acted four times, dark blood being still passed, but in diminishing quantities. On the following day the baby took the breast well and the stools gradually became normal. Since then progress has been uninterrupted and the child is now healthy and with a good colour.

R. DOUGLAS LAURIE, O.B.E., M.B.,
Honorary Assistant Surgeon, Derbyshire
Royal Infirmary.

DIPHThERIA AND FOLLICULAR TONSILLITIS.

DURING the last ten years in a general practice I have been accustomed to divide all cases of sore throat with exudates into three clinical groups: (1) Those which are plainly diphtheria, with an exudate present on other parts as well as on the tonsils. (2) Those which are plainly follicular tonsillitis. (3) Cases which are doubtful but are probably diphtheria; swabs from these cases yielded practically in all instances the Klebs-Loeffler bacillus.

The number of cases in the last group was small in proportion to the other two, about 5 per cent. of the total. I have observed normal convalescence in the follicular group; that there were only four "dissents" in ten years from the fever hospitals regarding the first group was reassuring. During the later period of the last epidemic, however, I was puzzled by two cases of definite follicular tonsillitis which did not lose the exudate after four or five days, and in each case a swab taken showed, on examination by a pathologist, the Klebs-Loeffler bacillus present. On account of this, swabs were taken from the next ten cases of exudative tonsillitis. In six cases, clinically follicular, the exudate was yellow, soft, pultaceous, in separate patches which did not coalesce and did not spread over the tonsillar boundary; there were no signs of haemorrhage on removing the exudate. In each case there was marked general malaise, a high temperature (102 or more), and pain on swallowing. In four of these six cases the Klebs-Loeffler bacillus was present, which to me was a startling result.

The other four cases were suspiciously like diphtheria: in them the patches of exudate coalesced, and the spread suggested that the exudate would pass beyond the tonsillar boundary. Of these cases, however, three were negative as regards the Klebs-Loeffler bacillus, and one, the worst, was a case of Vincent's angina.

These results raise in my mind one or two questions. Do epidemics of diphtheria differ as to their clinical manifestations? If not, why were the clinical tests I have been accustomed to apply in former years useless in these cases? Is it not extremely likely that the epidemics are caused by cases so plainly follicular, as far as clinical examination can go, that no swab is ever taken? In the face of the facts given above, is it safe for the general practitioner ever to rely on the clinical signs, however definite, in cases of sore throats with exudates, to give an answer to the question of whether a case is diphtheria or not? I for one, after this experience, will never feel that I can rely on the differential diagnosis by clinical signs.

London, S.W.

W. H. PALMER, M.B., B.S. Lond.

BRADYCARDIA.

THE following case may be of interest on account of its long duration. We first saw W. W., the patient, fifteen years ago, when he was 70 years of age and was employed as a blacksmith. He complained of attacks of unconsciousness suddenly coming on while at work. These

attacks lasted for about five minutes, and occurred several times during the course of a day. The patient's pulse rate was then 37 a minute, and the attacks were evidently an instance of the Stokes-Adams syndrome. As a result of prolonged rest gradual improvement took place in his general health, and the attacks became much less frequent and finally ceased. During the whole period, however, the pulse rate gradually slowed down to about 25. The previous medical history reveals no illnesses. The patient's general health is now good, but a double senile cataract prevents him from walking much out of doors. In regard to his cardio-vascular system the pulse rate is 25 per minute at the radial artery and at the apex, and the pulse is quite regular. The arteries are extremely calcareous. The apex beat is in the fifth space, $\frac{1}{2}$ -inch outside the nipple line. There is no enlargement of the heart to the right. Harsh systolic murmurs are heard at the apex and the base of the heart. There is no oedema. The other systems show no evident abnormality. We have been unable to have a polygraphic tracing taken, but we consider the case to be one of heart-block.

H. C. WOODHOUSE, M.B.,
F. CARLTON JONES, M.B., M.R.C.S.

Dawley, Salop.

TREATMENT OF LOCAL LEISHMANIASIS.

I was interested to note the short paragraph by Dr. Norman Gray (March 12th, page 382).

As bacteriologist to one of the large British hospitals in Basra I had an opportunity of studying hundreds of cases of "Baghdad boils." I entirely disagree with the statement that scraping is the best treatment for the infection.

We had tried every possible form of treatment, including scraping, with varying success, but found that the only satisfactory treatment was a full pastille dose of *x* rays. Previous *x*-ray treatment had always been disappointing, because, as was pointed out by Major Norman in a War Office Memo. in 1918, the rays had been given in successive small doses. After a full dose rarely was a second dose after four weeks necessary. Healing took place within ten days, and—more important still—one did not have the prominent "bluish" cicatrization which is a feature of all other forms of treatment.

G. F. MITCHELL, M.B.,

London. Late Pathologist 40th British General Hospital.

Reports of Societies.

EXAMINATION BEFORE ANAESTHETIZATION.

At a meeting of the Section of Anaesthetics of the Royal Society of Medicine on March 5th, with Dr. H. J. SHIRLEY, President, in the chair, Dr. R. W. APPERLEY read a paper on the importance of the examination of patients by the anaesthetist previous to the administration of anaesthetics. He pointed out that improvements in anaesthesia during the last fifteen years had been not in the increased number of drugs at our disposal but in the variety of more scientific methods of administering them. This placed on the anaesthetist an increased responsibility in his choice of method. There was still room for improvement both in diminishing fatalities and in reducing after-effects, and one step towards this lay in thorough examination of patients some time before operation. The condition of the cardio-vascular, respiratory, and nervous systems could only be ascertained in this way, as well as the efficiency or otherwise of the kidneys. Previous examination gave the anaesthetist time to think out the line of action best suited to the individual. Moreover, cumbersome or elaborate apparatus might be required which would not be present unless the need for it had been appreciated beforehand. The examination was an advantage to the patient, who felt that nothing was being left to chance; to the anaesthetist, who might glean important facts for his guidance; and to the surgeon, who was able to rely on the anaesthetist's guidance as to the patient's ability to stand a prolonged operation. The physician, who seldom saw an operation, was not so well qualified a guide. The risks which a patient ran were not confined to serious operations. For minor ones they were often grave, just because the slightness of the operation led to neglect of necessary precautions regarding the anaesthetic. In private practice

patients in nursing homes were at hand and could be seen on the day before operation. In hospital practice there was routine examination by house officers, and the anaesthetist was supplied with the information acquired. One class of patient which was admitted to the cancer department of the Middlesex Hospital had especially emphasized the importance of a preliminary examination—cachectic debilitated persons, often with secondary growths in the mediastinum or pleura and obstructed air passages. These cases made one extremely cautious in examination before deciding to give an anaesthetic.

Dr. W. J. McCARDIE read a paper on "Explosion of ether vapour during laryngoscopy":

A man of 56 was given open ether to induce anaesthesia for laryngoscopy and removal of a piece of the vocal cord. For some minutes before the laryngoscope was introduced ether with oxygen was given through a nasal catheter in addition to ether from the mask. The mouth being opened, ether and oxygen still passing in through the nose, Mr. Woodman began to introduce Hill's electric laryngoscope. It had not entered more than an inch when there occurred two or three loud reports like small pistol shots, and flames issued from the patient's mouth. These were five or six inches high, and like those seen if a bottle of ether were set on fire. The nasal tube was at once pulled out and the flames quickly died. Anaesthesia was continued with chloroform and oxygen without trouble. There was no obvious burning—merely reddening of the mouth and pharynx—and the patient recovered normally and had no after-cough. At the time of the explosion the room (temperature 65° F.) was lit by two $\frac{1}{2}$ -watt bulbs and one Osram bulb under a shade $2\frac{1}{2}$ feet away almost directly over the patient's head. The bulb of the laryngoscope light did not fuse and the light appeared in order and there was no evidence of short-circuiting.

Commenting on this case, Dr. McCARDIE said that no heat could be felt by the hand when the light was first switched on. The warm room, warm mouth, warm electric light, warm ether and oxygen, would all help towards the explosion. Ether vapour would take fire at a considerable distance from the source of heat. Dr. Squibb had seen ether take fire at a measured distance of 15 feet between the source of escaping vapour and the source of fire. Considering the absolute coincidence of the explosion with the introduction of the lamp, the cause must be found in the electric bulb of the laryngoscope. Dr. McCARDIE related the only other recorded case of ignition of ether vapour in the presence of a closed electric light, and other members of the Section brought forward instances of ether vapour ignition under various circumstances.

FAECES IN ALIMENTARY DISORDERS.

At a meeting of the Pathological Section of the Liverpool Medical Institution, held on March 17th, with Dr. R. W. MACKENNA, Vice-President, in the chair, Dr. ROBERT COOPE read a paper on the faeces in alimentary disorders. He outlined the normal characters of the faeces and emphasized the almost complete absence of food residues in the normal stool. If food residues were found in the stools in any notable amount there was (a) some failure of digestion, or (b) failure of absorption, or (c) hurrying on of the food—that is, diarrhoea. He was convinced that, though specialized chemical operations were sometimes necessary, in most cases a comparatively simple technique was adequate for all clinical purposes. It was essential to control the diet if valid deductions were to be drawn, and drugs should be withheld for some days before examination, especially oily bodies like olive oil and liquid paraffin, and purgatives, which might cause irritation of the gut or interfere with normal digestion. He divided the examination of stools into macroscopic, microscopic, and chemical, demonstrating the methods employed. Macroscopically, the most important abnormalities to be looked for were connective tissue, mucous flakes, and parasites. Slides demonstrated the microscopic appearances of normal and abnormal muscle fibre remnants, fats, starch granules, vegetable debris, etc. The chemical tests for stercobilin, blood, and soluble albumin were outlined, and the value of examining both chemically and cytologically. The value of a saline lavage of the large bowel was emphasized.

Two kinds of abnormalities were distinguished—(a) absence of normal constituents, and (b) presence of abnormal constituents. In the first category was stercobilin, derived from bile pigment by the reducing action of the intestinal bacteria, absence of which indicated that bile was not reaching the intestine. In the second

category were certain food residues, blood, soluble albumin and mucus. The appearance of connective tissue in any notable amount in the stools proved that there was failure of gastric digestion. The significance of imperfectly digested voluntary muscle fibre was discussed and two types of associated digestive trouble were mentioned—(1) those associated with definite pancreatic insufficiency, and (2) those in which there was no satisfactory evidence of pancreatic trouble. In both cases there might be excessive protein putrefaction in the large intestine, with indoxyluria, colitis, and sometimes general toxicæmic symptoms. The abnormal presence of starch grains often indicated nothing more than a diarrhoea, sometimes the condition of so-called "carbohydrate dyspepsia," which was due either to excess of carbohydrate food or to some infection or catarrh of the small intestine. He did not regard it as indicative of pancreatic disease. As regards fat, Dr. Coope thought there were two fundamental questions to ask: (1) Was there excess of any type of fat in the stool? (2) If so, was it an excess of split or unsplit fat? In his experience microscopic examination was usually quite adequate for clinical purposes. As the important point in the latter question was to learn whether the neutral fat of the food had been split into glycerin and fatty acid to the usual extent, no clinical purpose was served by distinguishing between the two types of split fat—namely, free fatty acids and soaps. Absolute excess of unsplit fat indicated pancreatic insufficiency, or a rapid passage of food through the intestine (for example, gastro-colic fistula). Absolute excess of split fat might indicate (a) marked diarrhoea, or (b) pancreatic insufficiency where means other than the pancreatic juice had split the fat, or (c) lack of absorption due to absence of bile or to disease of the gut wall (for example, sprue, amyloid disease). The significance of blood and soluble albumin were then discussed. Mucus was normally unrecognizable, but might occur abnormally as flakes intimately mixed with the faeces, incorporated in the small intestine or in the initial portion of the large bowel, where the faeces were still fluid. In such cases the cause was probably irritation, bacterial or chemical, of the gut wall, or possibly diarrhoea. Again, it might occur as mucus surrounding the formed faeces, produced in the terminal portion of the large bowel. Here it was usually due to constipation. In putrid fluid faeces, as in typhoid, the abnormal mucus might be digested and not appear in the stools at all. Dr. Coope then cited various cases illustrating the value or otherwise of various findings in the stools.

PUBLIC HEALTH LABORATORIES AND PREVENTIVE MEDICINE.

At a meeting of the Society of Medical Officers of Health, held on March 18th, with the President, Lieut.-Colonel F. E. FREMANTLE, M.P., in the chair, Dr. A. T. NANKIVELL opened a discussion upon "The relation of the laboratory to preventive medicine." After referring to existing county and county borough laboratories, he said it was doubtful if it was desirable to multiply the number of small laboratories; though where the medical officer of health was sufficiently qualified, a small laboratory properly staffed might be most useful, especially in speedily dealing with diphtheria specimens. He advocated wholesale swabbing of school children in face of an outbreak of diphtheria, and deprecated the practice adopted in some of the hospitals of the Metropolitan Asylums Board of discharging diphtheria patients without previously taking swabs of them. He urged every medical officer of health who had a laboratory to undertake some research work.

Dr. E. W. GOODALL said that he had given up the routine practice of requiring two negative swabs before discharging a patient from hospital, and he found that his results were quite as good, if not better, than in those hospitals where swabbing was resorted to. Surgeon Rear Admiral BASSETT-SMITH, Dr. MONKTON COPEMAN, and other speakers insisted that the virulence test must be applied when deciding whether a positive result was really dangerous. The PRESIDENT said that the war had opened our eyes to the fact that the laboratory had a wider view than that of the prevention of diphtheria. In

Mesopotamia plague could not have been kept down without the assistance of the laboratory, where rats could be quickly examined and the affected bazaar located. He disapproved of the setting up of small laboratories.

Reviews.

CEREBRAL DEVELOPMENT AND FUNCTION.

IN 1894 Dr. PAUL FLECHSIG delivered his memorable address at the University of Leipzig, afterwards (1896) published in the book entitled *Gehirn und Seele*. His pioneer researches were of epoch-making importance, for he showed that there was a time correspondence in the myelination of neuronic systems, during the development of the central nervous system and their manifestation of function. Although the hopes that were entertained by Flechsig and his followers regarding the possibility of an anatomical explanation of cerebral function have not been fulfilled, yet certain fundamental principles have been established.

The method of study which he employed was a systematic examination of sections of the brains of a number of foetuses, of newborn infants, and of infants of various ages after birth stained by the Weigert-Pal method. He was able to determine the successive stages in the myelination of neuronic systems and the times in which these appeared. The inference that myelination is indicative of preparedness for function is the fundamental principle, and in the main Flechsig's investigations are in accordance with the psycho-physiological evolution of the child.

The structures at the base of the brain, for the most part, and the cerebellum were found to be myelinated before birth; whereas in the newborn infant the cerebrum only exhibited isolated regions of myelination around the primary fissures—namely, the central, calcarine, and the Sylvian; these are the regions of the primary projection centres of movement and of the special senses. The remainder of the cortex is not myelinated, and constitutes the association centres, as yet unprepared for function. Upon anatomical grounds, therefore, it may be postulated that a child at birth may have a simple sensation. Since after birth every visual or auditory sensation tends to activation, especially to exploratory tactile-motor reactions, simple sensations give place *gradatim* to more and more complex perceptions and memories of the associated experiences; correspondingly there is more extensive myelination indicative of preparedness for these increasingly complex functions of perception and memory.

Flechsig's new book¹ is a continuation and extension of these studies. He divided the cortex according to myelogenesis but without regard to the anatomical point of view into primordial, intermediary, and terminal areas. The plates, twenty-five in number, are extremely well executed, and exhibit in a striking manner the successive stages of prenatal myelination, commencing with the brains of foetuses of 32 to 43 cm. long; they show also post-natal myelination of premature and normal newborn infants that had lived days, weeks, and months—the oldest being 9 months—and lastly the brain of an adult aged 40 years. Whether all the intermediary and terminal areas of myelination described by Flechsig can be supported by these investigations or not, they show clearly that there exist three areas of successive myelination—namely, (1) primary sensory-motor, adjacent to primary fissures; (2) psycho-sensory-motor cortical areas, adjacent to the primary sensory-motor areas; and (3) terminal associational, in the frontal, temporal and parietal lobes. This myelogenic evolution, indicative of preparedness for function, in a broad way conforms to the phylogenesis of the cortex. In the primordial region we find interposed in the normal cell lamination neurones which serve as the arrival and departure platforms of sensory-motor impulses. In the adjacent psycho-sensory-motor areas (intermediary areas of myelination) there is a characteristic cell lamination, and it may be postulated that these areas are concerned with elaboration of the sensory-motor functions of the primordial

¹ *Anatomie des Menschlichen Gehirns und Rückenmarks auf Myeloanatomischer Grundlage*. By Paul Flechsig. Leipzig: Georg Thieme, 1920. (Demy 8vo, pp. 121; 25 plates, 8 5/8 in. 41 ss. 3 s.)

regions, whereas the terminal areas of the frontal, parietal, and temporal lobes are especially concerned with the integration of the primordial and intermediate areas. The first evidence of association is in the corpus callosum, which associates the sensory-motor functions of the two hemispheres. Myelination can be seen commencing in this structure in the newborn full-term infant. When there is evidence of complete myelination the whole cortex is prepared for function, and there is a psychic unity whereby the whole seat of consciousness is involved in even the simplest action.

The more important conclusions stated by Flechsig in this volume may be stated as follows: With full term birth cortex fibre myelination is divided into two approximately equal phases of four months each. In the prenatal period sixteen primordial areas of myelination can be differentiated, ten of them being sensorial areas and six of them autonomous fields of unknown significance. After birth the fibres medullated are at first related to those already functioning. But later on two new groups mature, the one consisting of projection systems related to the primordial areas and in anatomical juxtaposition to them; the second group of terminal areas has representatives centrally situated in the frontal, parietal, and temporal lobes respectively, and their function is to co-ordinate all the projection systems around.

In all, Professor Flechsig differentiated forty-five areas of myelination in the cerebral cortex, and his studies also mark off certain very definite tracts in the white matter. He proceeds to correlate these findings with those from pathological secondary degenerations obtained by other observers, and he considers that the following deductions can be drawn:

In the first place, those areas whose destruction causes sensory or motor loss coincide with his primary sensorial areas. Secondly, one primary sensorial area is not directly connected with others, nor is it in promiscuous relationship with the whole of the remaining cerebral cortex. The only exception which appears likely concerns smell and taste, whose areas are in intimate interrelationship. A developmental study of the fasciculus longitudinalis inferior shows that it consists of smaller units, and Professor Flechsig protests against findings in the lower mammals being hastily assumed to hold good for man. Between two primary sensorial areas intervene at least two bordering zones, and, in addition, perhaps a terminal area.

He thinks it probable that the study of aphasia will demonstrate that memory pictures of sensations are preserved in the intermediate areas bordering on the sensorial, but whether the terminal areas are to be regarded simply as organs for associated memory traces must be left for future investigation to determine. It may also show that the cortex can be regarded functionally as divisible into territories, related each to a sensorial area, and concerned in the elaboration of one kind of sensory data.

The study of myelination throws an interesting light on the composition of the corpus callosum, which develops *pari passu* with the cerebral cortex. This study has important bearings on macroscopical brain anatomy also. For example, the Rolandic fissure separates the frontal and parietal lobes, and yet it is placed in the centre of a small area which has a distinctive development of its own. Again, other sulci are in juxtaposition to several areas of widely different development. Sulci in relation to the primary sensory areas, such as the Rolandic or calcarine fissures, are constant; those of later development vary widely in situation. The first temporal convolution is always related to auditory sensations, but, on the other hand, the third frontal convolution includes three areas differing in myelogenesis.

Professor Flechsig finds that his frontal and parietal terminal areas correspond exactly to the frontal and parietal eminences, and he holds that within narrow limits, and more especially in the child, the extent of development of these areas affects the shape of the skull.

This book can be commended, not only for the account of the valuable researches it contains, but also for the excellent way in which it is illustrated by coloured plates with descriptive text.

FREDK. W. MOTT.

NERVE INJURIES.

THE volume, *Injuries of the Peripheral Nerves*,² is in many respects a challenging book, in many respects an admirable one. We can imagine that some who have saturated themselves in the subject of nerve injuries will disagree with a number of things to which Mr. SOUTTAR commits himself without a tremor or a hint that any other manoeuvre might be tried in its place. But since very few are in agreement on certain aspects of this vexed subject, this is not an essentially important point. Unanimity of opinion is not yet to be found, particularly as regards the results of various kinds of operations. This book must be taken as giving us the views of Mr. SOUTTAR and Mr. TWINING on nerve injuries. No one reading it will be in any doubt as to what the authors' views are. They are clearly and dogmatically expressed, so that those who have only an elementary knowledge of nerve injuries can pick the book up and quickly render themselves much wiser men.

The arrangement of the chapters is excellent, and the authors have been well advised in keeping them on the short side. No lack of continuity has resulted from this, and it makes the book vastly easier to read. The changes in the nerve itself following injury are lucidly described, and a chapter is given to that vital point—changes in the surrounding and distal tissues and the influence of such changes on the final result obtained. Then follows a short account of the methods of examination of these cases in general and of the various nerves in particular, illuminated from time to time by short histories of cases. These have been well chosen, and include civilian injuries as well as war wounds, thus rounding the tale to its great benefit.

Descriptions of the technique of operations of various kinds occupies a great part of the book. Exception must be taken to the drawing tight of the tension suture in end-to-end junction of the divided nerve. Indeed, individual operators will find in the pages hereabouts a great deal with which they may disagree. Particularly is this the case with the "bulb-flap" operation figured on pp. 76 and 77, a proceeding physiologically unsound, although the author claims a success for it in Case 14. A similar objection will be raised with regard to the anastomosis or shunting of the distal end of a divided nerve into the side of a nerve previously sound. The authors state that the operation can be carried out without any permanent injury to the contributory nerve. They state that one-third of any ordinary nerve may be divided without any permanent loss of function. This is tantamount to saying that any nerve injury which involves not more than one-third of its fibres will lead to no disability of moment. We should have imagined that their experience with nerve injuries would have taught them that this is too sweeping a statement altogether. In spite of these objections Mr. Souttar and Mr. Twining are to be congratulated on a good piece of work. They have made the subject easy, indeed too easy. For after reading this book the uninitiated will believe that nerve injuries are rather simple things with which to deal.

We will not close this notice without a few words of congratulation to Messrs. John Wright, the publishers. They have produced a book which, in these degenerate days of printing and binding, it is a pleasure to handle.

PSYCHOLOGY AND PSYCHOTHERAPY.

DR. WILLIAM BROWN has published a number of articles on the psychological principles which underlie the modern theory and practice of psychotherapy, and in his book entitled *Psychology and Psychotherapy* he evidently intends to develop his views in more systematic form. This aim has not been quite successfully accomplished, and it would probably have been more satisfactory if Dr. Brown had decided to publish his book merely as a collection of essays on psychological topics. As it is, there are abrupt changes of theme, a number of repetitions, and a relative absence of a progressive development of any particular line of thought; all this rather tends to bewilder the reader.

² *Injuries of the Peripheral Nerves*. By H. Souttar, C.B.E., F.R.C.S., M.Ch. Oxon., and E. W. Twining, M.R.C.S., L.R.C.P. Bristol: John Wright and Sons, Ltd. London: Simpkin, Marshall, Hamilton, Kent and Co., Ltd. 1920. (Roy. 8vo, pp. 162; 30 figures. 18s. 6d. net.)
³ *Psychology and Psychotherapy*. By William Brown, M.A., M.D. Oxon., D.Sc. Lond. With a foreword by William Aldren Turner, C.B., M.D. London: Edward Arnold. 1921. (Cr. 8vo, pp. xi+196, 8s. 6d. net.)

Much attention is given to Freud's views, and a number of critical comments are made in respect to them. Dr. Brown does not accept the theory that the psychoneuroses are invariably the expression of maladaptation in the sexual sphere, but he has found the psycho-analytic method a valuable therapeutic measure. He does not, however, employ this method in its pure form, but relies largely on what he terms autognosis for the treatment of his cases. While "free association" forms part of his treatment, he utilizes explanatory, persuasive and suggestive methods as well. We believe that Dr. Brown is perfectly right in stating that suggestion plays a large part in the psycho-analytic method. It certainly does if we can go by the published accounts. It is frequently stated in authoritative psycho-analytic journals that the analyst points out to the patient the sexual symbolic meaning of the manifest content of his dream. This is, of course, direct suggestion, but, as the author observes, it is impossible to exclude unconscious suggestion however carefully the psycho-analytic technique is carried out. He expresses the view that there are four fundamental and relatively independent psychic factors at work in the cure of mental illness, namely, psycho-synthesis, psycho-catharsis, autognosis, and the personal influence of the physician.

In the sphere of purely academic psychology Dr. Brown contributes an interesting chapter on the theories as to the relation of mind and brain. He gives an account of Bergson's interaction theory, and himself favours the views expressed in *Matter and Memory* rather than the parallelistic hypotheses. It would have been of service if the author had developed these questions rather more fully, but he has suggested points of view which are of definite value. We note with a certain amount of surprise that Dr. Brown refers to telepathy almost as if it were a subject which had reached a stage of proof and was no longer debatable.

Though certain criticisms of this book have suggested themselves, it contains, as might be expected in view of the wide knowledge of the author, many features of interest to the psychopathologist.

DISEASES OF INFANTS AND CHILDREN.

PROFESSOR CROZER GRIFFITH, of Philadelphia, has written a comprehensive book on *The Diseases of Infants and Children*.⁴ It is founded on a long experience of hospital and private practice, and of teaching. The arrangement of the volume follows the usual plan, beginning with the anatomy and physiology of child life, infant feeding and relative food data, passing to infectious and general diseases, and then dealing with diseases of the various systems. The number of illustrations, both photographs and clinical charts, is large, and the short reports of cases appended increase the clinical character and practical value of the book, and can, indeed, be studied independently of the text. The coloured plates are also to be commended, especially those of the infant's normal and abnormal stools. The numerous references to medical literature include not only current, but also historical literature. Indeed, they are so numerous as sometimes to overload the text and obscure the author's own individual experience.

The book is as nearly encyclopaedic as it is possible for the book of one man to be, yet the treatment of some important aspects of disease in children is curiously slight. In dealing with rickets and scurvy, recent important work upon vitamins is merely mentioned. Also, America has in the last five years produced many careful and illuminating investigations upon clinical types of anaphylaxis and their diagnosis by the specific protein tests, yet this subject is only glanced at. The large subject of mental defect and imbecility is compressed into ten pages. These, however, are small defects in comparison with the great merits of the book. Above all other things, it bears the stamp of long and sound clinical experience—nearly forty years of practice and teaching; and the author's very numerous contributions to medical literature have already made his name familiar to practitioners on this side of the Atlantic. The book will be valuable not only to the specialist in the subject, but also to the practitioner in his daily dealings with sick children.

⁴ *The Diseases of Infants and Children*. By J. P. Crozer Griffith, M.D., Ph.D. Philadelphia and London: W. B. Saunders Co. (Double roy. 16mo; 2 vols., pp. 885 and 657; with 435 illustrations, including 20 coloured plates. 72s. net.)

DISEASES OF THE NEWBORN.

WHEN, in 1914, Dr. RITTER VON REUSS's work on the diseases of the newborn appeared in Austria, it was reviewed at some length in the pages of this JOURNAL (1914, vol. i, p. 918); and the opinion was expressed that it constituted a safe and reliable guide in dealing with the diseases of early life. A great deal has been written about neonatal diseases since 1914, and the whole subject has been greatly advanced; in particular, a resolute effort has been made to understand better and to treat more effectively the maladies of the first month of life, bearing in mind that at no other time is mortality so high. The English translation, published under the title *The Diseases of the Newborn*,⁵ is therefore welcome. There are one or two slightly mysterious features about the volume. The title-page, (which bears the date 1920) shows no name of a translator, although, let it be said at once, the rendering is admirable. On the paper cover, however, Dr. JOHN D. ROLLESTON is described as the reviser of the translation. Further, there is no preface or prefatorial paragraph explaining the purpose or the occasion of the translation. Curiosity regarding these matters remains unsatisfied. The reader will, none the less, be glad to have Dr. von Reuss's work in its English dress. There is a very long bibliography of some fifty pages, but it is weak in its references to British contributions to neonatal pathology and medicine: for instance, Ashby and Wright only appear in a secondary fashion as quoted by another author, and not a few of the original titles of English articles are lacking, being represented by what seem to be headings from foreign literature lists. The publishers, however, have turned out the work sumptuously, and deserve a word of praise.

NOTES ON BOOKS.

MR. PAUL BOUSEFIELD feels that there is no book on psycho-analysis which exactly meets the needs of the practitioner unversed in the technicalities of psychology and psychotherapy, and his book on *The Elements of Practical Psycho-Analysis*⁶ aims at remedying this deficiency. In view of the enormous output of literature dealing with this subject it would seem that there must already be plenty of books from which the practitioner might make a selection, and it is thus somewhat difficult to support the author's contention. In any case the influence which Mr. Bousefield anticipates the new psychology will have on future social customs is so unattractive that many readers will be tempted to wish a speedy end to the whole movement as he presents it.

In his book on *Psychoanalysis: its History, Theory, and Practice*,⁷ Mr. ANDRÉ TRIDON endeavours to present an unpartisan treatment of his subject. He deplores the antagonism between the leaders of the various schools of thought, and attributes this mainly to personal animus among them. The author covers a wide range of problems which he seeks to interpret in accordance with the theories of Jung, Freud, and Adler. The same author is responsible for another book on similar lines entitled *Psychoanalysis and Behaviour*.⁸ Here he shows himself strongly influenced by the work of Dr. Edward J. Kempf, and he gives a useful outline of his theories of behaviour. There is little doubt that Dr. Kempf's physiological interpretations of human reactions are of considerable significance, and they may do much to replace the metaphysical formulations of Freud and Jung, though his actual views are inspired by Freud to a large extent.

The issue of *Medical Science, Abstracts and Reviews* for April is the first number of a new volume—the fourth. It contains, among other reviews, one on alimentary diseases, with a copious bibliography, and another on non-tuberculous juvenile coxalgia. Two indexes to Volume III are supplied, the one of subjects and the other of authors.

⁵ *The Diseases of the Newborn*. By August Ritter von Reuss, Director of the Department for the Newborn at the First University Women's Clinic in Vienna. Translation revised by John D. Rolleston, M.D., B.Ch., M.A. (Oxon.), assistant medical officer, Grove Hospital, Tooting. London: John Bale, Sons, and Danielsson, Limited. 1921. (Roy. 8vo, pp. 638, 30 figures. 52s. net.)

⁶ *The Elements of Practical Psycho-Analysis*. By Paul Bousefield, M.R.C.S., L.R.C.P. London: Hegan Paul, Trench, Trubner and Co., Ltd. 1920. (Demy 8vo, pp. viii + 276. 10s. 6d. net.)

⁷ *Psychoanalysis: its History, Theory, and Practice*. By André Tridon. London: Hegan Paul, Trench, Trubner and Co., Ltd. 1920. (Cr. 8vo, pp. 272. 10s. 6d. net.)

⁸ *Psychoanalysis and Behaviour*. By André Tridon. London: Hegan Paul, Trench, Trubner and Co., Ltd. 1921. (Cr. 8vo, pp. 354. 10s. 6d. net.)

EIGHT of the principal publishing houses in Paris which issue medical and scientific books have combined in the production of a *Bibliographie des Livres Français de Médecine et de Sciences*. It is a joint catalogue of books published by the eight firms in the years 1908-20. The books are classified according to subject and particulars as to size and price are given. The volume is provided with an index of authors' names and with a list of periodical publications. It is a new departure very much to be commended and one worthy of imitation. Copies can, we understand, be obtained on application to the Section de Médecine du Syndicat des Éditeurs, Hôtel du Cercle de la Librairie, Boulevard Saint-Germain, 117, Paris (VI).

MEDICINE IN PUBLIC LIFE.

MEDICAL DINNER AT EXETER.

THE Minister of Health, Dr. Addison, was the chief guest at a dinner given by the Mayor of Exeter (Mr. Arthur C. Roper, F.R.C.S. Edin.) to the members of the medical profession at the Guildhall, Exeter, on March 30th.

Proposing the health of Dr. Addison, Dr. ROPER said no function during his term of office, so far, had given him greater pleasure than that of entertaining a large number of his professional friends, old and young. Some, but not many, were his seniors; a good many were his contemporaries; others were his juniors, and some of them he knew very well and intimately. Referring to the presence of the Minister of Health, the Mayor said that Dr. Addison occupied a unique position in the medical profession. He was looked upon from widely divergent points of view, but, whatever the view, they must all recognize him as one of themselves—(Hear, hear)—as one who, equally with themselves, was doing his best to serve and to benefit the health of the nation. In asking the company to drink Dr. Addison's health, Dr. Roper wished him every success in piloting the ship that bore a precious cargo safe to the haven where he would receive the gratitude of a benefited and healthy nation. (Applause.)

SPEECH BY THE MINISTER OF HEALTH.

Rising to respond, Dr. ADDISON received an ovation. He said the man who deserted a professional career and entered upon the uncertain path of a political life was looked upon somewhat as a suspect by the average professional man. He was glad that, at all events, the citizens of Exeter had recognized that medical men in their city council could and ought to render service. And what was true of the city of Exeter he thought ought to be true in the councils of the State. It always seemed to him to be a singular drawback to their profession that, immersed as most of them were in attendance upon the individual, they were apt to overlook, or perhaps they had not time to think about, the community of which that individual formed but a single part. They did not require to think far before coming to recognize that there were some things which as professional men they knew should be done, and could be done, but which could not be accomplished under any circumstances by individual effort. They could only be brought about in some measure by the collective action of instruments of government in some form or another. He believed that a good many medical men regarded the medical politician as a suspect because they did not quite see what he was getting at. The reason for that, he thought, was because their profession was so interesting and their work so absorbing that they had neither the time nor the disposition to study health questions from the State point of view. Whether or not that was the explanation, he recognized the fact and endured it with all the fortitude he could. While there had grown up in this country a collection of responsibilities, powers, and duties, scattered about through various departments of the State, concerned more or less with promoting, preserving, or protecting the life and health of the individual citizen, they had never been brought together, organized collectively, and directed as one so far as was possible. The Ministry had not yet been at work very long; it had had a good many teething troubles—(laughter)—while they were not without their critics—(renewed laughter)—especially in certain sections of the Press, who were much interested in the promotion of a "stunt," as they called it, or in ventilating a personal grudge sometimes against a Minister of Health—he being, for the moment, a useful vehicle—but who were not so

anxious perhaps at all times to state or consider the facts of the case on their merits, and so it came about that there were many things which had never been stated or even understood.

Housing as a Preventive Health Service.

In the first place he thought that the organization of the health services of the State and their development ought to be with the Government the motive for increasing the value and efficiency of the services for the prevention of sickness and disease. No subject undertaken at the Ministry of Health had brought them more ridicule, should he say, than that of housing, but he put housing first as a preventive health service. A start had been made, and they at least knew where they were going. For the first time a duty had been cast—and he did not apologize for its being a duty—upon local authorities to make a return as to what were the needs of the community in terms of houses. According to the 1911 standard two million people were said to be living under insanitary conditions. Well, he wanted to alter that standard. It was useless to talk of stamping out tubercle when so many people were compelled to live in houses condemned as unfit for human habitation. It might well be that it would take twenty years to get the rehousing of this country on a well established basis; but that was a matter of no consequence. What mattered was that they had obtained a minimum standard based upon the health requirements of the nation affecting the lives of the people two-thirds of the hours they lived. The measure was more essential, he believed, to improving the health and well-being of the child and other population than any other one measure that could have been taken up. (Applause.) It was true they had been beset with all manner of difficulties, but they had ploughed their way through some of them. No enterprise had ever succeeded without difficulties, and they would be overcome in time. Soon they would be coming to the second stage—the allocation to every city and town within the limits of finance available a sum to help in dealing with the insanitary dwellings in their midst, and he believed the views of the medical profession thereupon would be unanimous. (Applause.)

Medical Guidance in Public Affairs.

Proceeding, Dr. Addison said there could be no doubt that the medical profession would, more and more, be forced into public affairs. Public opinion and the spread of education would do it. It was one of the first requirements of their profession that there should be bodies of men in the different districts, and some bodies central, who were accustomed to meet together to consider and discuss public questions in which professional knowledge or interests were concerned, so as to obtain from time to time as required, and to be able to give, responsible and considered professional advice. Public bodies and also the State, he thought, had often gone wrong, or missed an opportunity because it had not had the guidance and advice from those, and those only, who knew—advice which it might have been possible to obtain. So it had come about that they had had difficulties owing to the lack of such advice, and he repeated what he had already said in London a short time ago—the request to his professional brethren to get busy on this matter.

Going on to refer to the question of hospitals, the speaker said the great masses of the people were needing more expeditious hospital treatment and that the accommodation available for them in the voluntary institutions at the present was insufficient. Side by side with this was the mass of empty accommodation, and it was impossible to think that they could go on for ever like that. There was the demand on the one side and the supply on the other; but the two never met, and because the Ministry were venturing to think a little in advance they got into trouble; still they were going on with it all the same. (Applause.) With regard to the cancer problem, Dr. Addison said he should like to see a more comprehensive attempt made to tackle it. Looking at the results from such knowledge as could be gleaned, it did not seem to him that they were much further ahead as yet. The tale of death was still as great, if not greater, and he thought there was a big opportunity for a wise expenditure of money in the interests of

economy. (Hear, hear.) Statistics showed that in 1918 58,000 died of tuberculosis in this country, the previous lowest year being 1913, when there were 49,000 deaths. In 1919 the number fell to 46,000, and last year it dropped to 42,000. As to the cost of the whole tuberculosis service, taking the country as a whole, it worked out at rather less than a penny rate in regard to expenditure of local authorities, and a farthing out of every £ in regard to the Exchequer. With regard to infant mortality, the death-rate in London fell to 85 in 1919, and last year was down to 75. He understood it was still going down, but it could go down to 50 if only they did the job properly.

In conclusion, Dr. Addison said that preventive medicine was the cheapest investment for the State. Well-considered and well-directed health efforts were cheap and paid, and they were only just beginning to see it in this country. But as they came to see it, the medical profession would be dragged right into it; of that there was no question, and therefore he had no manner of doubt that, as on every other occasion which had called for their response, they would rise to it quite easily in their singularly characteristic British fashion. But he was quite sure that the time was at hand, and great would be their opportunity. (Applause.)

INDUSTRIAL FATIGUE AND VENTILATION.

THE latest report of the Industrial Fatigue Research Board consists of a volume of preliminary notes on atmospheric conditions in boot and shoe factories. The first report of this series, which was mainly introductory, gave a short history of the industry and a condensed description of the processes carried on, and also certain information relating to individual differences in output.

The present report, which deals with the practical use of the katab-thermometer as an indicator of atmospheric conditions from a physiological aspect, is based upon observations made in a number of boot and shoe factories under varying conditions, and also, for purposes of comparison, in an aircraft doping room. The katab-thermometer, it will be remembered, was devised by Dr. Leonard Hill in the course of his researches into the subject of ventilation. It is designed to measure its own rate of cooling at a temperature approximately that of the human body, and has an alcohol reservoir in the form of a cylindrical bulb, a stem graduated in tenths of a degree from 95° F. to 100° F., and at the top a small bulb, which acts as a safety overflow when the thermometer is heated, and readings are taken with the "katab" used both as a dry bulb and as a wet bulb thermometer. Hitherto no systematic attempt has been made to investigate on a large scale the particular aspect of ventilation which determines the physiological state of the person exposed to it—that is, the cooling power of the air—in order to correlate it with fatigue and production. A means of measuring this effect is now, however, afforded by the katab-thermometer, and it was accordingly decided to start a series of observations in boot and shoe factories with the object of studying the importance of this factor of the workers' environment.

The inquiry has not yet progressed far enough to justify any definite conclusions as to the relation of atmospheric conditions to fatigue and efficiency, but, having regard to the novelty of the method of observation involved, there is a certain advantage to be gained by the publication of this preliminary report indicating the conditions actually existing in different departments. The katab-thermometer deals only with the physiological effect of ventilation, as measured by the cooling power of the air. It takes no count of other aspects of ventilation such as the avoidance of infection and the rate of change of the air in the room—that is to say, the replacement of stale air by fresh. This instrument, moreover, is much more susceptible to local conditions than is the thermometer, so that any given reading can only be taken as applying to the point of observation. It is designed to measure rates of cooling that are dependent on temperatures, humidities, and velocities of air currents, and rates of cooling give information with regard to standards of comfort and efficiency.

As the result of the investigations, which were carried out first under the direction of Professor T. Loveday, M.A.,

and later of Professor E. T. Collis, M.D., the report points out that an atmosphere which will help to sustain physical energy should be cool rather than hot, dry rather than damp, and there should be brisk air movement. Neglect of these conditions may cause physical disability and inefficiency.

There is some evidence to show that atmospheric conditions deteriorate from morning to evening in the workshop, and also that this makes additional demands on the workers' energy. Examination of summer and winter records taken at several factories suggests that systems of ventilation which are adequate in winter cannot always ensure desirable physical conditions under adverse outdoor conditions in summer. Machinery in motion has an appreciable effect on atmospheric movement, and careful consideration should be given to the ventilation in small rooms used for special processes which are shut off from main air currents. Consideration of ventilation in single and multi-storied buildings indicates that the latter structures have slightly higher rates of cooling, a narrower range from winter to summer atmospheres, and a greater air velocity. Experiments carried on in an aircraft doping room showed the high rates of cooling obtained by frequent air change at high velocity, and the application of the doping-room system of ventilation to boot and shoe factories was considered. A study of the atmospheric conditions in the principal departments suggests that rates of cooling and atmospheres were not adapted to the nature of occupations. For instance, there was some indication that "clicking" rooms were too cold in winter and too hot in summer; that the air velocities in each department were greater in summer than in winter; and that the summer rates of cooling in press rooms were below the standards recommended. In other departments, such as lasting and finishing rooms, where heavy manual work was in progress, rates of cooling and atmospheres for both summer and winter were found to be unsatisfactory.

An interesting section of the report shows the effect of clothing on skin temperatures, and the principle is illustrated that comfort during working hours could be enhanced by a more careful choice of clothing. Conversations with operatives showed that the heavy worker too often has the idea that profuse perspiration is a necessary consequence of his occupation, and he guards against chill by wearing heavy woollen garments which absorb moisture; but light clothing would be preferable because of its effect in allowing the free circulation of air between the garments and the skin.

This report is a further example of the useful work that is being carried on by the Industrial Fatigue Research Board, and gives one more reason—if that were needed—why this work ought to be continued for the benefit of the nation as a whole.

PRESENTATION TO DR. J. A. MACDONALD.

THE following further subscriptions have been received from March 1st to April 4th, 1921, in response to the appeal published in the JOURNAL of July 24th, 1920 (p. 129), towards a presentation to Dr. J. A. Macdonald on the occasion of his retirement from the office of Chairman of Council of the British Medical Association which he had held for ten years. Subscriptions of any amount not exceeding five guineas should be made payable to "The Macdonald Presentation," and sent to the Medical Secretary, British Medical Association, 429, Strand, London, W.C.2.

FIFTEENTH LIST OF SUBSCRIBERS.

	£	s.	d.		£	s.	d.
Brought forward from last list of subscribers	50	3	6	Per Dr. J. Hume (Honorary Secretary Perth Branch)			
Bigger, Sir E. C., Dublin	1	1	0	Per Dr. J. MacInnes (Honorary Secretary Stockton Division)			
Bone, Dr. J. W., Luton	2	2	0	Kirk, Dr. T. J., Norton-on-Tees	2	2	0
Palmer, Dr. W. M., Linton, Cambs.	0	10	6	MacInnes, Dr. J., Norton-on-Tees	1	1	0
Per Dr. J. Melvin (Honorary Secretary, Rochdale Division)				Ross, Dr. A. N., Stockton	1	1	0
Wilson, Dr. S., Rochdale	1	1	0	MacBean, Dr. D. S., Stockton	0	10	6
Carse, Dr. W. H., Rochdale	1	1	0	Per Dr. T. Ferguson (Honorary Secretary, Otago Division, New Zealand Branch)	10	10	0
Melvin, Dr. J., Rochdale	1	1	0				
Mackintosh, Dr. F. W., Rochdale	1	1	0				
Per Dr. T. Ferguson (Honorary Secretary, Otago Division, New Zealand Branch)							
	935	17	0				

British Medical Journal.

SATURDAY, APRIL 9TH, 1921.

THE SCIENCE OF ETIOLOGY.

IN the mid-Victorian period the students of infectious disease had practically only two weapons, the clinical and the statistical. The former gave us such fundamental observations as the discrimination between typhus and typhoid fever, the latter a long series of fruitful generalizations, particularly as to water-borne disease, associated in this country especially with the names of Simon, Radcliffe, Buchanan, and Power. This was succeeded by a period during which thought was dominated by the astonishing achievements of the bacteriologists with regard to etiology, which the more sanguine spirits hoped would prove to be at once directly applicable for prevention. A great deal was accomplished, but not all that was hoped or even promised, and an inevitable reaction ensued, which was presently reinforced by the appearance of a new school of statistical epidemiologists provided with mathematical methods unknown to its Victorian predecessors. If to the plain man bacteriologists seem to have gone too far in apparently ignoring all but the bacterium, the new statistical etiologists seem to have proceeded to the verge of the absurd.

It was such considerations that induced us to publish, in our issue of March 19th (p. 432), an article entitled "The New Epidemiology." In it we endeavoured to point out that to ensure its future progress epidemiology must make use of two different implements, the bacteriological and the statistical, the underlying assumption being, of course, that both must rely for their fundamental data on clinical medicine. That both methods, bacteriological and statistical, must be used in the study of etiology might seem to be a truism, but we were quite prepared to incur a charge from either side of obscurantism, although pains were taken to avoid affording any justification for it. The accusation has come from the bacteriological side, and we take pleasure in publishing—for the subject is of immense importance—the following criticisms from the pen of a distinguished bacteriologist, written, as we understand, in consultation with a no less distinguished clinician.

"If Medicine," they write, "is not yet an exact science, it is doubtless because our experiences of disease, and our efforts to control it, yield exceedingly difficult material upon which to base sound conclusions. But the complexity of the processes involved, and the gaps in our knowledge, must not blind us to the greatness of the achievements of research. And since most of the advances in Medicine of recent years have been made possible by progress in our knowledge of causation, the growing science of etiology may be regarded as a sure measure of progress. An exact knowledge of causes is one of the most difficult and elusive of all quests in Medicine. In the case of the infective diseases, where some of the chief progress has been made, the problem is complicated by the circumstance that two of the factors involved are living organisms of independent vitality, of complex physiology, and each imbued with a tendency to vary. The causes of these variations

both of microbe and host have still to be adequately determined."

"It would appear," they continue, "that there are at least two procedures for advancing the science of etiology. The first, which is the method of the vast majority of research workers to-day, may be described as follows: By persistent endeavour; by a patient and accurate collection of facts; by well-controlled and repeated observation; by appropriate and 'light-giving' experiment; by withholding conclusions until the ascertained data are adequate; and, finally, by considering all the evidence with due regard to each portion of it, to arrive slowly perhaps, but nevertheless surely, at certain knowledge. The method of the newer science of epidemiology is distinct from this. Instead of accumulating facts in laborious fashion, it aims at a solution of the problem by postulating causes and apparently by eliminating the principle of specificity. It may readily happen that a plausible explanation of any set of phenomena can be found which may satisfy the imagination for the time being. The ultimate value, however, of such a hypothesis depends not only upon its ability to account for a certain set of observed data, but upon its fate when tested by the stern reality of experience in the widest sense. Not the least valuable of the services rendered by bacteriology was the prompt dispersal which it effected of the dim mists of 'miasmology.' It is possible that the practical physician who finds that small-pox is derived from small-pox, measles from measles, and tuberculosis from tubercle, will be more inclined to believe in the strict specificity of such diseases, and in accumulated experience, than in a conception, however elastic and 'gap-filling'—such as that put forward by some of the exponents of the newest statistical epidemiology.

We venture only one comment, which is that it would be a mistake to limit the term "research" to experiments in bacteriological and chemical laboratories; we feel sure that our correspondents did not intend so to limit it, but on a hasty perusal it might seem as though they did.

RECURRENCE OF BILIARY CALCULI.

IT is well established that calculi may re-form in the gall bladder after the operation of cholecystostomy and removal of what foreign contents there may have been within. This is, in fact, one of the chief arguments put forward in favour of cholecystectomy as against mere drainage. It is, however, known that trouble may sometimes recur after removal of the gall bladder entire, that such removal is not an absolute insurance against further biliary trouble. Some persistent discomfort in the right hypochondrium may be due to infective cholangitis or lymphangitis within the liver itself—a gall-stone cirrhosis. This complication is usually of a low grade and of far from outspoken symptomatology, and yet commoner, perhaps, than we realize.¹ But the chief and disturbing trouble which is liable to cause distress to the patient and discomfort to the surgeon is the recurrence of biliary colic after cholecystectomy has been well and truly performed.

Undoubtedly the most fertile source of after-trouble is the incomplete removal of stones at the primary operation. Notwithstanding that the surgeon to-day explores the biliary tract with care, every now and then a stone or stones are left behind. Sometimes there is a recurrence of symptoms in patients in whom the bile passages are known to have been cleared

¹ Peterman, Friest, and Graham: "The Association of Hepatitis with Experimental Cholecystitis," *Arch. of Surgery*, January, 1921, 92.

previously. Such cases always raise the question as to whether a stone can form anew, from nothing as it were, within the common and hepatic ducts. In many recurrences the possibility cannot be excluded that a stone may have wandered up into the intra-hepatic pathways and so been overlooked. But when, after the finding and removal of such a calculus, symptoms of cholelithiasis come back again and yet again, the idea arises that the stones have been recreated in the bile ducts. It is known that these last are not pre-eminently the birthplaces of stones, which as a rule form within the gall bladder, and there are those in whom this belief is so strong that they would deny that a biliary calculus can arise elsewhere. It must be admitted that the most skilled surgeon after an exemplary search may fail to discover a calculus lodged within a small branch of the duct system within the liver substance, and that this calculus may later wander into a large duct and then be obvious to all.

This problem has been discussed by Deaver,² by Judd,³ by Eisendrath,⁴ and quite recently by Emerson Brewer.⁵ Judd's figures from the Mayo clinic include 219 secondary operations on gall-stone cases. Eighty per cent. of these were for removal of a previously drained gall bladder. In six cases stones had to be removed from the common duct after a precedent cholecystectomy. In one case Judd removed a large stone from the common duct on three separate occasions, the gall bladder having been excised at the first sitting. Brewer's cases are of great interest. A woman had a cholecystostomy performed in 1911. Eighteen months later stones were removed from the common duct and the gall bladder excised. After a similar period of time trouble recurred and several large dark brown stones were found in the common duct. The duct system was explored by finger and probe well within the liver substance and left clear. Eight months later a fourth operation was undertaken and seven stones were scooped out, three high up in the hepatic ducts, well within the liver. One and a half years later a fifth operation was done and two or three stones removed. Experiences such as these point strongly towards the new formation of duct calculi. Unfortunately, Brewer does not give an account of the minute structure of the stones. Pigment calculi are the most likely to form without the agency of the gall bladder mucosa.

Lastly, in connexion with this subject reference must be made to Lewisohn's⁶ interesting case of intra-hepatic cholelithiasis. Here stones within the liver parenchyma perforated through it and caused local peritonitis. Again, stricture of the duct and periductal adhesions are causes of persistent trouble which must not be forgotten.

THE FIRST MINISTER OF HEALTH.

DR. CHRISTOPHER ADDISON will always be remembered in the history of health and public health in this country if only because, as President of the Local Government Board, he carried through the bill by which the Ministry of Health was established. The bill, in its general structure, was well conceived, and met the wishes expressed by the British Medical Association and other medical organizations. It was in accordance with expectation that Dr. Addison

became the first Minister of Health. The Ministry came into existence on July 1st, 1919: to it were transferred all the powers and duties of the Local Government Board, together with those of the Insurance Commissioners for England and Wales. Other powers were to be transferred to it, but, as things stood, the task before the new Ministry was gigantic; it had to satisfy the expectations for better health conditions of the medical profession and the public generally, and, in particular, it had to attempt to make good the serious deficiency in housing, a deficiency which had been considerable before the war and had been greatly increased by the almost complete suspension of building during its progress. Obviously housing is of first importance in all health questions, but it is unfortunate that so much of the energy of the Minister had to be given up to this one subject, that so many obstacles—some of them unnecessary—were thrown in his way, and that he so early lost the services of Sir John Anderson, who had been specially selected to be second secretary of the Ministry in charge of housing. It is unfortunate also that the Ministry so early lost the services of a great public servant—one intimately acquainted with the more strictly medical side of its work and eager for its extension—by the death of Sir Robert Morant in March, 1920. At the beginning of that month Dr. Addison, in a review of the administrative action of the Ministry, gave some account of what had been undertaken in matters directly affecting health. He referred in particular to the strengthening of the powers of port sanitary authorities and to the multiplication of child welfare and midwifery centres, and mentioned some of the improvements it was intended to introduce into the insurance service. During last session the bill to remove sanatorium benefits from the National Insurance scheme and to place the treatment, other than domiciliary, of tuberculosis within the province of the local authorities was passed.

Commenting on the situation at the end of last May we observed that the hardest worked of all Government departments was the Ministry of Health, and asked for the sympathy and encouragement which its energetic efforts deserved. The subsequent history of the Ministry was not fortunate, and we cannot doubt that, as we pointed out at the time, Dr. Addison's position was seriously compromised by the introduction into an omnibus bill last autumn of legislation profoundly affecting the constitution of general hospitals. The mistake was seized upon by a certain section of the press, anxious, as we must suppose, to attack Mr. Lloyd George through his consistent supporter, Dr. Addison. Dr. Addison remains a Cabinet Minister, but we should have preferred to see him still at the Ministry of Health. It was a very great advantage in the early days of that Ministry to have a man who was by his training well aware of the professional outlook and ready, as on several occasions he showed, to attach due weight to the advice and criticisms of the profession. It would have been an advantage had he continued to be head of the Ministry now that some of the difficulties we had almost said the artificial difficulties—the Ministry has encountered have been got out of the way.

THE ANNUAL MEETING AT NEWCASTLE.

THE details of the programme for the Annual Meeting at Newcastle-upon-Tyne are being gradually settled. The Representative Meeting will begin on Friday, July 15th, at 10 a.m., and will be continued on Saturday, Monday and Tuesday. On the latter day the statutory Annual General Meeting will be opened at 2 p.m., and will be resumed at

² Deaver: "Resurrence of Gall Stones," *Surg., Gynec., and Obstet.*, 25, 1917.

³ Judd: "Recurrence of Symptoms following Operations on the Biliary Tract," *Ann. Surg.*, April, 1918.

⁴ Eisendrath: "Recurrence after Operations on the Biliary Passages," *Journ. Amer. Med. Assoc.*, 1917, lix, p. 1752.

⁵ Brewer: "Recurrence of Calculi in Common and Hepatic Duct after Cholecystectomy," *Arch. of Surg.*, January, 1921, p. 145.

⁶ Lewisohn: "Intrahepatic Cholelithiasis," *Ann. Surg.*, May, 1916.

8 p.m., when the incoming President, Professor David Drummond, C.B.E., will give his address; it will be followed by a reception in the Grand Assembly Rooms at 10 p.m., with the President and Mrs. Drummond as hosts. The Sectional Meetings begin on Wednesday, July 20th. The scientific work is to be dealt with in seventeen sections, of which five meet on each of the three days. Proctology and Urology are separate units this year, and each will hold a one-day session; this is a new departure which, it is hoped, will give an opportunity for useful discussion along special lines. The dates on which the several two-day and one-day sections will meet were announced in a Current Note in last week's SUPPLEMENT. The names of the officers of the various sections were announced in the SUPPLEMENT of March 5th, and those desirous of taking part in the work of any special section are invited to communicate direct with the honorary secretaries, whose addresses were there given. A special effort is being made to encourage interest in the afternoon demonstrations, which were very numerous attended at Cambridge last year. They are more informal than the morning sessions, and actual cases, specimens, apparatus, etc., are shown and discussed. At 8 p.m. on Wednesday, July 20th, there will be a Special Address in Industrial Medicine, by Sir Thomas Oliver, and on Friday, July 22nd, at 7.30 p.m., Professor Arthur Keith will deliver the popular lecture in the King's Hall of Armstrong College on "Evolutionary wounds, their healing, and the part they play in the evolution of the human body." The social arrangements already planned include, in addition to the President's reception, a garden party in Jesmond Dene, when the Association will be the guests of the Lord Mayor, an evening reception by the Branch Council, to be followed by a dance; and other evening parties at which dances have also been arranged.

R.A.M.C. WAR MEMORIAL.

SUBSCRIPTIONS in response to the appeal for funds to establish a war memorial to the officers and men of the R.A.M.C. who lost their lives in the war amount to about £19,500. Of this, £1,500 was ear-marked by the donors for the benefit of families and dependants, and at a meeting of the general committee, held recently under the chairmanship of Sir Alfred Keogh, it was decided that it should be divided between the R.A.M.C. Regular and Auxiliary Funds in proportions to be decided after the wishes of the committees at Portsmouth and Netley had been ascertained. The amount available for the purposes of the memorial itself will, it is anticipated, be, in round figures, £18,000. The proposal made to the meeting and eventually adopted by it unanimously was of a novel character, and will, we believe, commend itself to the Corps and to the medical profession generally. It has three parts: the first is to erect in Westminster Abbey, on the wall in a suitable position near the grave of the Unknown Warrior, a tablet commemorating the memory of the officers and men of the R.A.M.C., Regular, Territorial, and Temporary, who fell or died in the war; the second is that a list of their names should be inscribed on a "Golden Book" kept permanently in the Chapter House of the Abbey; and the third that a contribution should be made to the fund for the restoration of the Abbey. It was at first suggested that some definite concrete part of the restoration, such as the embellishment of a chapel, should be undertaken, but the Dean and Chapter, after consideration, found that the nature of the work being done was such that it was difficult, and in fact impossible, to set apart any particular section; it was accordingly decided to give the sum of £10,000 to the Abbey Restoration Fund and that the gift should be recorded on the memorial tablet. The Dean and Chapter entered cordially into the project for the permanent preservation of the "Golden Book" and for the erection of the tablet. The Director-General, vice-

chairman of the committee, read the correspondence he had had with the Dean, and stated that when the proposal was placed before the Colonel-in-Chief of the Corps, Field Marshal the Duke of Connaught, he had shown himself most sympathetic and appreciative. The proposal, which it was understood originated with Colonel C. R. Tyrrell, C.B., C.B.E., R.A.M.C.(ret.), was commended by Sir Norman Moore, President of the Royal College of Physicians, by Sir Arthur Sloggett, and Sir Launcelotte Gubbins. Sir Anthony Bowlby, President of the Royal College of Surgeons of England, who was unable to be present at the meeting, has also expressed his entire approval. It was decided that photographs of the tablet, together with a plan of the Abbey showing its position, should be sent to the relatives of each person mentioned in the Golden Book, and that replicas of the memorial tablet should be given to Edinburgh and Dublin. The production of the book would, it is estimated, cost between £3,000 and £4,000. The tablet, with replicas, will cost a considerable sum, but it is not yet possible to specify the exact amount. An Executive Committee to carry out the proposals was appointed, consisting of the Director-General (chairman), Sir Norman Moore, Bt., Major-General Sir W. G. Macpherson, Sir Launcelotte Gubbins, Staff Sergeant Walton (members), and Colonel Tyrrell and Major E. B. Waggett, D.S.O., R.A.M.C.(T.F.), (joint secretaries).

RESEARCH IN RADIOLOGY.

LAST week (p. 500) the necessity for the provision of research facilities on a large scale into the properties of radium and x rays was discussed, and the present opportunities for research such as are afforded at the Radium Institute and the Middlesex Hospital were mentioned. Much of the increased opportunity for research work in radio-therapy that exists at present has arisen through the Medical Research Council, which has obtained from the Disposal Board of the Ministry of Munitions the use for a period of years of a large quantity of active radium salt for research purposes. The radium was collected from various parts of a great variety of war implements, and is of the estimated value of £72,500. The Council has prepared a scheme for the assignment of various fractions of this radium to selected centres of work where the results of its use can be adequately studied. Hitherto the opportunities of inquiry have been limited by the high cost of radium, and there has been little systematic and comprehensive study of its curative properties. There is evidence, the Council observes in its annual report for 1920, that radium used ignorantly or in improper exposures—whether too large or too small—may accelerate death instead of preventing or delaying it, and that in particular the onset of secondary malignant growths may be hastened or actually caused by unsuitable radium treatment of the primary growth. Without close study, and without the collection of adequate contemporary and later records, for which at many of the centres of work sufficient opportunity has not hitherto been found, it is impossible for these grave dangers to be detected or avoided. The Council has assigned radium fractions to a number of centres: in London, to University College Hospital, St. Bartholomew's Hospital, the Middlesex Hospital, King's College Hospital, and the Radium Institute; in Birmingham, to the General Hospital; in Dublin, to the Council for Public Health for Ireland; negotiations with other centres have been opened. Much of the research carried on during 1919 under the auspices of the Medical Research Council was conducted at the Middlesex Hospital, where elaborate precautions were taken to protect laboratory workers and nurses from the physiological effects of so large a quantity of radium; the radium, which was in the form of the bromide, was contained in eighteen tubes, which were kept in a circular brass box placed in the centre of a cubical box of lead, each edge of which measured 20 in. This leaden cube, weighing one

ton and a half, was enclosed within an iron safe as far away as possible from rooms in daily occupation. The radium box itself was never directly handled, but was moved from place to place as required by means of a "long arm" and a special lead-protected trolley; the treatment of patients was carried out in a separate room, with the aid of lead-screened apparatus. All this special apparatus was provided by the Medical Research Council. During this early stage of the investigation over one hundred patients were treated. Of these the great majority were inoperable, but prophylactic doses were given in four cases of operable carcinoma before operation. Four cases of cancer of the breast, inoperable before massive radium treatment, were subsequently considered by the surgeon to have become operable, and underwent a "complete" operation. No conclusions could be drawn from these early cases, but a remarkable diminution in the size of the tumour in cases of lymphosarcoma and lymphadenoma was observed. Microscopical examination of bone marrow in rabbits submitted to radiation, carried out by Dr. Price Jones in Professor Boycott's laboratory at University College Hospital Medical School, showed that the behaviour of lymphosarcoma was closely paralleled by the destruction of leucocytes in the blood, spleen, and lymphatic glands of animals. The experiments on rabbits and other animals exhibited in a striking way the selective action of the rays upon particular organs of the body or particular parts. The whole of the material from the animal and human cases has not yet been examined, but microscopical examination of the brains of the animals is being made by Sir Frederick Mott in his laboratory at the Maudsley Hospital. Investigations with x rays have an immediate bearing upon problems of radium treatment, and the experiments regarding the general effects of small doses of x rays upon animals have been continued on behalf of the Council by Professor S. Russ and his colleagues at the Middlesex Hospital. Facilities were given also to Professor Sir William Bragg, of University College, for experiments in the direction of standardizing the radium radiation against that of a Coolidge tube running under known conditions. All these investigations must have a fundamental value in guiding administrations of x rays to patients.

ROYAL NAVAL DENTAL SERVICE.

THE new regulations governing entry into the Royal Naval Dental Service, which have just been issued, suggest that the Admiralty desires to place this newly formed branch of the service upon a sound basis. The neglect of the teeth of the personnel of the navy has been at least as bad as the neglect of the teeth among the population in general. It was only in 1892 that the first attempt was made, at Haslar, to pay any attention whatever to dentistry in the navy, and it was not until the second year of the war that the first naval dentists were commissioned as officers of the R.N.V.R. After the war was over, the nucleus of a permanent dental service for the navy was formed, and its future now depends upon the response made to the invitation conveyed in the new regulations by the young qualified dentists of the country. The qualifications for admission to the dental service are very similar to those for the medical service of the navy: A candidate must be of British birth, of sound physique, ready to engage for general service at home or abroad, and be registered under the Dentists Act. The dean, or other responsible authority, of his dental school will be requested to render a confidential report on his character and professional ability, and, after an entrance examination, which will be held twice a year, successful candidates will enter the service arranged in order of merit. Should it at any time be considered expedient to grant commissions beyond those periodically competed for, the Admiralty takes power to admit annually two candidates specially recommended by the governing bodies of such

Dominion or Colonial dental centres as may be selected, on condition that they pass a qualifying test. Before a successful candidate is given a commission as Surgeon Lieutenant (D) in the Royal Navy he will be required to pass through a course of one month as decided upon by the Admiralty, and his commission will be confirmed on passing the qualifying examination at the end of this course. The subjects for the entrance examination will embrace dental surgery, including dental pathology and therapeutics, oral hygiene and oral prosthetics; candidates must obtain at least 50 per cent. of marks in each subject. A post-graduate course of three months' duration will be allowed to Surgeon Lieutenant Commanders (D) of over two years' seniority, and the officers going through this course will be accommodated at the Royal Naval College, Greenwich. This post-graduate course is designed to afford senior officers the opportunity of refreshing their general knowledge of dental surgery and making themselves familiar with modern advances. Their status in the navy is designed to be good, and "dental officers will select their cabins (all ward-room officers make such selection in order) according to their rank and seniority." The dental officer on a ship will be responsible directly to the captain. Surgeon Lieutenants (D) will receive as pay from £401 to £492; Surgeon Lieutenant Commanders (D), £593 to £730; and a Surgeon Commander (D), £775 to £912. There are to be forty-eight officers of the Royal Naval Dental Service, but of these only one can hold the rank of Surgeon Commander (D). As the service is only now at its beginning it is clearly very possible that the first officer to hold the rank of surgeon commander may retain his post for many years, thus blocking promotion absolutely. If the work of the dental service is to be carried out in the manner that everyone hopes, it is sufficiently important for an officer of the rank of surgeon commander to be stationed at each of the larger naval depôts, and at Haslar. In this way the risk of the service becoming rather a blind alley form of employment would be avoided.

INTERNATIONAL RED CROSS CONFERENCE.

THE first session of the tenth International Red Cross Conference, which assembled in Geneva on March 30th, was occupied in listening to an interesting address by the president, M. Ador, and in the appointment of committees. It was decided that, following the precedent of the League of Nations, the Red Cross Society of a British Dominion should be admitted to the conference on an equal footing with those of other countries, and that similar recognition should be accorded to the Red Cross Society of the Netherlands Indies. Including those of Canada, South Africa, Australia, New Zealand, India and the Netherlands Indies, thirty-six Red Cross societies were represented; among them were the Red Cross societies of Germany and Austria, and the Red Crescent of Turkey; representatives of the Papal Government, of the League of Nations, of the International Labour Office, and certain societies, including the newly formed International Union for helping children, were also present. Neither the French nor the Belgian Red Cross was represented, because there are questions still open between the Governments of these two countries and Germany, and because both France and Belgium desire an assurance, described by the President of the Conference as very legitimate, that doctrines which during the war led to systematic violations of the Geneva Convention, would be disavowed. The French Red Cross, however, sent reports to this conference and expressed the hope that it might be able to be represented at the eleventh, as it had been at the ninth, held in Washington in 1912. At the second full session it was decided, on the motion of Mr. R. B. Bennett, K.C., representative of the Canadian Red Cross Society, to appoint a committee to report on the violations of the Geneva Convention committed during the war, in order that those guilty of such violations should be arraigned at the bar of

public opinion. Other commissions were appointed to prepare reports on the revision of the Geneva Convention, on the position of the Red Cross in civil war, and on the relation of Red Cross societies to Governments and to philanthropic associations. It will be remembered that a League of Red Cross Societies was organized in May, 1919, and that shortly afterwards its headquarters were established in Geneva, with Lieutenant-General Sir David Henderson as Director-General. The president of the international conference was able to announce at its third meeting, on April 1st, that he and Sir David Henderson had come to an understanding with regard to the work of the International Committee of Red Cross Societies and the League of Red Cross Societies, and that this understanding had been ratified by both bodies. The Italian representative moved a resolution to issue an appeal to all the nations, calling upon them to combat the war spirit which still persists throughout the world. The resolution was supported by Dr. Livingstone Farrand, the representative of the United States, and by the representatives of Greece and Persia; it was carried unanimously. Throughout the discussions in the conference many references were made to the work which Red Cross societies can do during peace. Most of the detailed work of the conference was done by the special committees appointed, and the reports of these will not as a rule be available for some time. It is to be noted, however, that the committee on the limitation of war early arrived at certain resolutions forbidding the bombardment of open undefended towns, the deportation of the civil population, and the use of poison gases. An exhibition held during the conference included displays by the Red Cross societies of Italy, America, Sweden and Norway, and also by the Turkish and German societies.

HYGIENE OF SEAMEN.

DR. G. S. BUCHANAN, in his address on the International Health Organization to be established at Geneva in connexion with the League of Nations,¹ expressed the hope that the organization would provide a means by which competent sanitarians would take their proper part in the international regulations of matters like ship ventilation, the construction of crews' quarters, and facilities for cleansing, and also as to rations—subjects to which the International Labour Office has begun to give attention. The Town Council of Newport, Monmouthshire, in its capacity as a port sanitary authority, has issued a report, in which it expresses the opinion that the British regulations for the hygiene of crews' quarters stand in need of immediate revision. During the war the agreements between the Controller of Shipping and those interested in the provision of better accommodation for the Merchant Service led to considerable improvements in standard ships; the report alleges that the improvements were not general and that they have not been maintained in recent vessels built for British firms. The conditions of living on vessels registered under the American flag are said to be so much better that many of the best British sailors and firemen are seeking service in American in preference to British merchant vessels. While it is admitted that many British shipowners have provided greatly improved accommodation in recent years, it is alleged that others have failed to do so. Valuable opportunities of effecting improvements in the large number of new vessels built during the last three years have been lost, and the suggestion is made that a committee should be appointed to advise the British Government as to the changes that should be made in the regulations so that this country may go to an international congress with clean hands. The proposed committee, it is thought, should contain representatives of the Board

of Trade, the Ministry of Health, shipowners, shipbuilders, officers and men of the Merchant Service, port sanitary authorities, and the Admiralty. The question of accommodation for crews on board ship is beset with many difficulties, and can only be settled in a satisfactory manner by the frank recognition of certain basic principles which govern those conditions on board merchant ships. Sanitary methods suitable for houses on shore are not directly applicable to ships. Limitation of space in a ship must in the end influence all questions of hygiene at sea. A ship is the result of innumerable compromises between all the departments of the vessel, and any serious encroachment on space in favour of one particular department may increase expenditure to an extent the industry will be unable to bear. As it is, it is not easy to run a passenger ship at a profit, and drastic legislation may easily result in a large number of ships being laid up. Such statistics as are available do not point to any serious ill health on board ship. The rate of mortality from disease of European seamen on board steamships is 3.5 per 1,000 and that for lascars 5.4 per 1,000; these figures are below those in industrial life on shore for the same ages. As to the incidence of disease, no statistics have ever been published, and the only records available exist in the archives of those companies that have paid attention to the subject. It can, however, be stated that these records do not reveal any startling incidence of disease. It is undoubtedly desirable to ascertain the experience of medical officers of the various port sanitary authorities, but it should not be forgotten that they for the most part see only one side of the question—namely, that concerned with infectious disease—and it is to be hoped that in any attempt to grapple with this question use will be made of the experience of those who have been responsible for the health of seamen employed by the various companies. The subject has an international side; a large number of vessels change their nationality in course of time, many of them soon after completion, and an international standard of hygiene is therefore necessary. It is, of course, recognized that international agreement is necessary in dealing with the possible importation of exotic diseases, such as cholera, yellow fever, and plague. It is important, however, that international arrangements should be susceptible of revision without long delay such as ordinary Foreign Office methods usually entail. Dr. Buchanan's suggestions for short-circuiting the chancelleries—that is to say, the Foreign Offices of this and other countries—appear to us to be among the most valuable yet made.

LABELLING OF SKIMMED CONDENSED MILK.

THE Food and Drugs Act, 1899, imposes a heavy penalty upon the importation of condensed separated or skimmed milk except in tins or other receptacles which are specifically labelled and the words "separated" or "skimmed" printed in large and legible type. A fine may also be imposed upon a tradesman who sells such milk which is not so labelled. It is to be regretted that the qualification "large and legible" is so indefinite that it may be interpreted according to the desires of the interpreter. Even though there might be some difficulty in following the Margarine Act and defining the actual size of the type to be used, it would be quite simple to require that the type employed for the particular word or phrase should not be smaller than that used in any other part of the label. It is not so much the actual but the relative size of the type that is of importance. We have been led to refer to this matter as we have reason to believe that there are some brands of skimmed condensed milk the tins of which are so labelled as to mislead the purchaser although the law may be strictly carried out. A mother, therefore, may be giving her child milk which she believes to be unskimmed but which has had abstracted from it all but about 0.2 per cent. of its fat. At the instigation of Dr. Walter Bassett.

¹BRITISH MEDICAL JOURNAL, March 5th, 1921, p. 331.

this question has, we learn, been under the consideration of the Health Committee of the Newport (Mon.) Corporation, and the seriousness of the position has been brought to the notice of the Ministry of Health.

SPELLING OF CHEMICAL TERMS.

THE progress of chemical inquiry, which is constantly bringing to knowledge new substances and new theories as to the constitution and relations of various classes of substances, is apt to cause confusion in nomenclature, especially in spelling. The Chemical Society, which publishes abstracts of chemical papers published elsewhere than in its *Transactions*, and is therefore among the first to feel the inconveniences which arise, issued a short time ago instructions to abstractors, which included directions with regard to spelling of certain classes of chemical compounds. It is directed that basic substances should invariably be indicated by names ending in *ine*—as aniline, not anilin. This is in accordance with the practice of the *British Pharmacopoeia*, where alkaloids have a final "e," as morphine, strychnine. The Chemical Society directs that the termination *in* should be restricted to certain neutral compounds, such as glycerides, glucosides, bitter principles, and proteins—as, for example, palmitin, amygdalin, albumin. This rule applies to vitamin, which should be so spelt—that is, without the terminal "e." It is further directed that compounds of basic substances with hydrogen chloride, bromide, or iodide should always receive names ending in *ide* and not *ate*, as morphine hydrochloride and not morphine hydrochlorate. This rule is, we believe, now generally followed in medical writings. Another rule relates to hydroxyl derivatives of hydrocarbons, which should be designated by names ending in *ol*. Alcohols should be spoken of as mono-, di-, tri-, or n-hydric, according to the number of OH groups. Compounds which are not alcohols, but for which names ending in *ol* have been used, are to be represented by names ending in *ole*, if a systematic name cannot be given—thus, anisole not anisol, indole not indol.

MINERS' HOUSING.

THE National Housing and Town Planning Council issues a weekly record for the benefit of the Housing Committees of local authorities. The current issue, describing the garden suburb now being developed by the Bristol City Council at Sea Mills, and the scheme of the London County Council for a new town at Beacontree in Essex, makes timely allusion to the housing of miners. With the recrudescence of difficulties in the mining industry, it says, deep interest will be taken in the view expressed by many responsible and unbiassed public men to the effect that a substantial part of the unrest to be found in mining districts—and more especially in the coal valleys of South Wales—is due to the absence of proper conditions of social life and of suitable housing conditions. "At its best, the mining village or town is not a thing of beauty. At its worst, the colliery slum, with its well-nigh primitive sanitary conditions and rows of back-to-back houses, can 'give points' to many of the worst slums of great industrial centres." It is alleged that the number of employers willing or able to take remedial action is small. One or two examples are then quoted to show that here and there the right kind of action is being taken; these, however, are said to be exceptional cases. "It is recognized by employers and colliery workmen alike that the task of providing homes for miners under happier conditions can only be adequately fulfilled by local authorities acting in co-operation with the State." Even now, however, nearly 100,000 houses are included in the building programmes of the local authorities for the various mining areas of England, Wales, and Scotland. It is said that the idea is rapidly growing amongst employers and workmen that it is not good

for those engaged in the mining industry to be segregated in villages and towns given over entirely to the housing of workmen engaged in coal mining. The Committee of the South Wales Regional Survey is understood to favour the development of fifteen new towns in the colliery valleys of South Wales, under such conditions that the miners may partake of the amenities of civilized life and live in closer touch with other members of the community. There is a great deal of truth and a certain amount of exaggeration in all this. In any large area where the greater part of the coal raised is exported to foreign countries, or even sent to other parts of our own country—and this is the case in large areas of the South Wales coal fields—it would be difficult to form communities containing any large proportion of persons engaged in other industries than the raising of coal. Nor are we at all sure that the task of providing homes for miners under happier conditions can only be adequately fulfilled through State help, or that the majority of employers are indifferent. It is perhaps not generally known that large anthracite areas are being taken up in South Wales. A cursory observation of the new towns erected or planned shows that they are free from the gross defects of the aggregates of houses that choke the valleys of the Rhondda district. The risk of such utterances as those of the Housing and Town Planning Council is that they may encourage both mine owners and miners to believe that it is hopeless to make a mining town or village a reasonably agreeable place to live in unless other industries than the raising of coal are there carried on.

TREATMENT OF TUBERCULOSIS.

IN accordance with that section of the National Health Insurance Act, 1920, which provides that sanatorium benefit shall cease to be included among the benefits of the National Insurance Act, 1911, after April 30th next, county and county borough councils have now received a circular letter from the Ministry of Health. It is pointed out that it will rest with these councils to provide institutional treatment for insured persons as well as for other members of the community, as Insurance Committees will after that date no longer have the duty of providing such treatment for insured persons suffering from tuberculosis. In practically every county and county borough a scheme for the institutional treatment of tuberculosis, comprising both dispensaries and residential institutions, is already in preparation or in course of development, and is available for the treatment of the whole population of the area. In the large majority of the areas agreements are also in operation by which the councils provide institutional treatment for insured persons suffering from tuberculosis in consideration of payments by the Insurance Committees. These agreements will come to an end when sanatorium benefit is discontinued, but in those areas in which the council has already undertaken by agreement with the Insurance Committee to provide institutional treatment for insured persons, no difficulty should arise in continuing provision by the council of the institutional treatment needed by such persons. In the remaining areas it will be necessary for the council to supplement the provision already made, either by taking over the arrangements made by the Insurance Committee for the provision of residential treatment, or by making other arrangements for that purpose under which an equivalent amount of residential treatment will be provided; there must of course be no interruption of the course of treatment provided by an Insurance Committee for any insured person. A separate memorandum has been issued dealing with the special arrangements which should be made by a council for the treatment of ex-service men suffering from tuberculosis. Provision is made for repayment to the council of the cost of residential treatment provided for ex-service men; the special services tuberculosis officers should render in relation to pension

administration are set out, and a new method of payment by the Ministry is formulated. By the National Insurance Act, sanatorium benefit of seamen and other persons employed in the mercantile marine suffering from tuberculosis was administered by the Seamen's National Insurance Society instead of by an Insurance Committee. A sum equivalent to the annual amount at present available for providing institutional treatment by that society will be distributed among the councils of those areas in which the society's members are located, and it is necessary that, as the majority of seamen have no permanent place of residence, cases of tuberculosis should be dealt with by the councils as a matter of urgency. As insured persons will no longer be in a position to apply to their Insurance Committees for sanatorium benefit after April 30th, cases of such persons and of other members of the community suffering from tuberculosis should be brought to the notice of the local tuberculosis officer at the earliest possible date, and it is suggested that councils should again circularize the medical practitioners practising in their areas drawing attention to the importance of utilizing freely the services of the local tuberculosis officers.

SIR WILLIAM THORBURN.

THOUGH Sir William Thorburn retired at the end of last year from the active surgical staff of the Manchester Royal Infirmary rather before the date required by the age limit rule, and in consequence ceased to be professor of surgery in the Manchester University, he has not given up teaching nor the practice of his profession. Since his election to be consulting surgeon he has been appointed to give lectures on the surgery of the nervous system at the Manchester Royal Infirmary: the first series will be given there during June next. Sir William Thorburn is at present in Rome, whither he went as president of the British Chirurgical Club, which exists to enable its members to study surgical methods of other schools and other countries. Sir William Thorburn's reputation as a surgeon is particularly high in the department concerned with the treatment of diseases and injuries of the nerves, and the profession, especially in the north of England, will be glad to know that it is not to be deprived of his experience and skill.

DR. THOMAS LEWIS, F.R.S., will deliver the Oliver-Sharpay lectures before the Royal College of Physicians of London, at 5 p.m., on Tuesday, April 12th, and Thursday, April 14th, at the College, Pall Mall East. The subject is: "Observations upon the nature of auricular flutter and fibrillation."

THE Right Hon. Evelyn Cecil, M.P., has retired from the office of Secretary-General of the Order of St. John of Jerusalem, and has been succeeded by Lord Stanmore. Mr. Cecil had held this, the chief executive office of the Order of St. John, since 1915. He became a member of the Joint War Committee of the British Red Cross Society and the Order of St. John five years ago, and has been vice-chairman of the Joint War Council for the last two years.

ON Friday, April 15th, at 5 o'clock, in the Museum of the Royal College of Surgeons of England, Professor Arthur Keith will demonstrate specimens illustrating the comparative anatomy of the caecum, appendix, and great bowel.

AT a meeting of the Central Midwives Board for England and Wales held on March 23rd, with Sir Francis Champneys presiding, one midwife was struck off the roll, one severely censured, two put on probation for reports in three and six months, and one case was dismissed, the midwife being cautioned to obey the rules strictly. Various appointments were made to fill vacancies caused by the resignation of examiners, and lists of examiners, lecturers, and institutions, homes, and midwives, at which and under whom pupil midwives may be trained, were approved.

Medical Notes in Parliament.

[FROM OUR PARLIAMENTARY CORRESPONDENT.]

The Ministerial Changes.

THE reconstruction of the Ministry, which has followed upon the retirement of Mr. Bonar Law and upon the occurrence of other vacancies, has brought numerous changes in the placing of members of the Government, and a small and valuable infusion of fresh blood. The list has been made familiar through the daily papers, and need not be referred to in detail here, except as regards the departure of Dr. Addison from the Ministry of Health and the selection of Sir Alfred Mond to fill that office. The fact that Dr. Addison remains a member of the Cabinet as a Minister without portfolio—that is to say, in a consultative and influential capacity—shows that he enjoys in a high degree the confidence of the Prime Minister; and inasmuch as under the Coalition arrangement the Cabinet appointments are—figuratively speaking—countersigned by Mr. Austen Chamberlain as leader of the Unionist party, there is evidence that Dr. Addison is also held in appreciation by the Unionist chief.

It may be assumed that the selection of Sir Alfred Mond is due mainly to the desire of the Prime Minister to have at the Board of Health a commercial man with better business qualifications than Dr. Addison, in the nature of his career, could possess for dealing with the housing problem, which is causing so much anxiety at the present time. Sir Alfred Mond had much experience during the war, as First Commissioner of Works, in arranging for the accommodation of emergency war services, and even in the ordinary way the position he has now given up to become Minister of Health afforded him special knowledge in this connexion. His wide responsibilities in chemical manufactures before he entered the Government trained him, moreover, to think largely and to estimate closely on these subjects. His capacity for handling big figures was shown also during fiscal controversies in pre-war days.

Happily there is no reason to fear that because Mr. Lloyd George's choice has been determined principally by the housing situation Sir Alfred Mond will be lacking in concern to take up health questions, or will fail in capacity or vigour in handling them. At the works of Messrs. Brunner, Mond at Droltwich and elsewhere keen anxiety has been manifested to recognize the importance of hygiene. Indeed, the nature of some of the undertakings has called for much care, and the directorate are proud of the scientific administration which has given such good results in the physical condition of the employees. With this record at the back of his mind, Sir Alfred Mond will, it is anticipated, desire to continue and promote a forward movement at the Ministry of Health in all things affecting the well-being of the people, and be sympathetic to the medical profession.

The new Ministers are generally considered to have been well chosen. There is satisfaction that at last the Air Ministry obtains a directly responsible head; to this work Captain Guest will bring energy and enterprise. Commander Hilton Young, who succeeds Mr. Baldwin as Secretary to the Treasury, has amongst private members shown himself far and away the ablest debater on financial subjects that recent years have produced. He doubtless gained some strength from experience earlier as the city editor of a London journal. Sir Robert Sanders, who was the right hand of Lord Edmund Talbot in the Whip's office, should prove highly capable as Under-Secretary for War; he is none the less efficient because he has shunned the limelight of politics. Major the Hon. E. F. L. Woods, the eldest son of Lord Halifax, has distinguished himself as a thoughtful and careful speaker, and his broad interests will find opportunity for service in the Under-Secretaryship for the Colonies. Altogether the juniors look likely to justify their selection.

The Bradford Municipal Hospital.—Mr. George Thorne asked the Minister of Health, on April 5th, whether he could state the present position in regard to the acquisition of a Poor Law infirmary by the Bradford Corporation, to which he had at one time given his sanction, which, as Mr. Thorne understood, was afterwards withdrawn. Sir Alfred Mond replied that provisional sanction was given to the scheme in June last, and this had never been withdrawn. But before giving a final decision the Minister of Health had urged on the Council the importance of full consultation with the medical profession in Bradford. As the result of this, a local advisory medical committee was appointed, and this committee had put forward certain suggestions which were being considered by the City Council, from whom a communication was expected to be received soon.

England and Wales.

SUPPLY OF MILK TO NURSING MOTHERS.

A CIRCULAR has been addressed to local authorities by direction of the Minister of Health stating that, in the supply of milk for expectant and nursing mothers and children under five years of age, many local authorities have incurred expenditure very greatly exceeding what is either necessary or desirable. This conclusion has been reached after a careful review of the cost of the schemes adopted throughout the country by local authorities with comparable needs. The Minister has accordingly reconsidered the arrangements to be observed as a condition of his sanction to schemes, and it appears to him that the necessities of those whom the service was designed to benefit could be met by a much lower rate of expenditure than that now being incurred. The Milk (Mothers and Children) Order, 1919, made by the Food Controller and the local authorities, and the Milk (Mothers and Children) Order, 1919, made by the Minister of Health, have therefore been revoked, and local authorities must in future obtain the sanction of the Minister of Health under the Maternity and Child Welfare Act, 1918, to schemes for the supply of milk to expectant and nursing mothers and children under five years. Milk may be supplied at less than cost price in necessitous cases only to (a) nursing mothers; (b) expectant mothers in the last three months of pregnancy; (c) children up to three years of age, and exceptionally to children between three and five years of age. The quantity of milk supplied at less than cost price must not ordinarily exceed one pint a day for each person, but in exceptional cases one and a half pints may be supplied for infants from three to eighteen months. Milk should be given only where the medical officer of health is satisfied that it is essential on grounds of health, and for exceptional cases a medical certificate will be required. A special committee should be appointed locally to lay down the procedure for dealing with applications for milk and to review all authorizations for supply. Reasonable steps must be taken by local authorities to verify the particulars of income given by applicants, and to prevent overlapping with other bodies concerned. Where dried milk or preparations of milk are used the quantity should be such as would, when reconstructed, approximate to the usual supply of fresh milk.

JOINT MEDICAL MEETING AT SHEFFIELD.

A joint meeting of the Sheffield Medico-Chirurgical Society and the British Medical Association was held on March 24th in the Firth Hall of Sheffield University, and the chair was taken by Dr. F. J. Sadler. Dr. Rupert Hallam gave a short account of his journey round the world as the medical member of a Commission which was dispatched to the Far East by the National Council for Combating Venereal Diseases with the approval of the Colonial Office. The Commission first visited New York, arriving there early in November, 1920, where Dr. Hallam had the opportunity of seeing several of the well known skin and venereal clinics. The majority of patients there pay for their treatment, but necessitous patients are able to obtain free treatment. Compulsory notification and treatment of venereal disease has been in force for more than a year, and the consensus of opinion is that this has not acted as a deterrent to patients to seek treatment. He next visited the New York State Laboratory at Albany, which is a large and well-equipped building. The Commission journeyed across Canada, making brief stays at Toronto, Winnipeg, Regina and Victoria, where meetings were held under the auspices of the Canadian Council for Combating Venereal Disease. In Japan useful information was obtained from the officials of the Government Health Department, and visits were paid in two hospitals in Tokio. At the invitation of the Shanghai Municipal Council the Commission conducted a campaign of public enlightenment in that city, and Dr. Hallam gave a series of lectures and demonstrations to the medical practitioners there in the diagnosis and treatment of venereal disease. The incidence of both syphilis and gonorrhoea among the Chinese in the seaport towns is very high, and before the visit of the Commission there was no treatment by modern methods available for them. The Commission conducted a

similar campaign at Hong Kong, Singapore and Colombo, and in each of these ports recommended that the free diagnosis and treatment of venereal disease should be provided.

Ireland.

THE LATE DR. J. A. HANRAHAN.

WE have received the following appeal, signed by Dr. James W. O'Connor, Professor of Physiology, University College, Dublin, and Mr. W. Doolin, M.B., F.R.C.S.I., Honorary Secretary of the Leinster Division of the British Medical Association, who write from 50, Fitzwilliam Square, Dublin:

"We ask the liberty of appealing through your columns on behalf of the widow and children of the late Jas. A. Hanrahan, M.B., a recent Dublin graduate. Dr. Hanrahan graduated in the Royal University in 1909; shortly after he went abroad to take up practice in Australia, from which country he returned home last year, to die of inoperable rectal cancer at the early age of 34. Unhappily he was too short a while in practice to make any effective provision for his family. His unhappy widow, herself seriously handicapped by reason of deafness, is now left with four young children to maintain. In these circumstances we would now appeal to your members and readers for any measure of assistance, however small, that they can afford. Subscriptions, which will be duly acknowledged, may be sent to either of us."

Scotland.

VITAL STATISTICS FOR 1920.

THE outstanding statistical facts derived from an examination of the annual report for 1920 of the Registrar-General for Scotland are high birth and marriage rates and a low death rate. The marriage rate, 9.6 per 1,000, is the highest Scottish marriage rate yet recorded, while the death rate, 14.0, is the lowest. The birth rate was 28.1, and is higher than that of all years since 1906. Deaths from tuberculous disease show a satisfactory decline. Deaths from whooping-cough were fewer than in any previous year, and those from measles also declined. Births registered in Scotland during the year numbered 136,535; this was 30,267 more than in the previous year, 31,258 more than the mean of the numbers of the preceding five years, and 22,599 more than the mean of those of the preceding ten years. It is the largest number of births registered in Scotland in any one year, the previous largest number being in 1903. The increase was due to large numbers in the first two quarters of the year only, there being no marked excess over pre-war averages in those of the latter two quarters. Deaths registered numbered 68,179, or 6,970 less than in the previous year, 6,876 less than the mean of those of the five preceding years, and 5,643 less than the mean of the ten preceding years. It is less than the number registered in any year subsequent to 1862. The natural increase of the population of Scotland during the year (the excess of births over deaths) was 68,556, a number greater than in any previous year since the institution of national registration—that is, since 1855. The birth rate was 28.1 per 1,000; it was 6.4 higher than that of the previous year, and higher than the rate of all years subsequent to 1906. The annual death rate was 14 per 1,000; it was 1.4 less than that of the previous year, and 1.5 less than the mean of those of the preceding ten years. It is the lowest annual Scottish death rate yet recorded. The deaths of children of less than 1 year old numbered 12,565, equal to an infant mortality of 92 per 1,000 registered births. This rate is 10 less than in the previous year, 15 less than the mean of the preceding five years, and is the lowest annual Scottish infantile mortality rate yet recorded. The death rate due to the principal epidemic diseases was 0.78 per 1,000. This is 0.14 less than in the previous year. The death rate from all forms of tuberculous disease was 124 per 100,000, and from phthisis 86. Both of these rates were the lowest yet recorded. Deaths from small-pox registered during the year numbered 152, which is the largest number in any year since 1904. Deaths from measles were fewer than

in any year since 1894, while from whooping-cough they are fewer than in any previous year. Deaths from cancer were more numerous than in any previous year; they outnumbered those attributed to phthisis by 1,563, or fully 37 per cent.

END OF GLASGOW SMALL-POX EPIDEMIC.

The last case of small-pox in Glasgow has now been discharged from hospital, and the city for the first time in twelve months is free from this disease. The epidemic started in March of last year, and altogether the Public Health Department dealt with 576 Glasgow cases and 26 cases from Rutherglen burgh and the County of Lanark. Of the total cases 119 proved fatal, the deaths without exception occurring among patients who had never been vaccinated or who had not been vaccinated for a considerable number of years. The disease was at its height towards the end of May, when there were 157 cases in hospital at the same time. About a quarter of a million persons were vaccinated by the officials of the Health Department, assisted by a large number of medical students, and the education authority carried out a systematic campaign of vaccination in the schools.

Correspondence.

ACIDOSIS AND ALKALOSIS.

SIR,—In his letter in the BRITISH MEDICAL JOURNAL of April 2nd Dr. Poulton suggests that what is known as diminished or increased "alkaline reserve" of the blood should be called "acidosis" or "alkalosis," regardless of whether the actual reaction of the blood is altered in the acid or alkaline direction. I feel sure that nothing but confusion could result if such a nomenclature were adopted; and mistakes have actually arisen in the past through taking variations in the "alkaline reserve" as in themselves an index of whether the blood is altered towards the acid or alkaline side. I need only instance the case of treatment of lung-irritant gas-poisoning by administration of alkalis, in disregard of the urgent danger from anoxaemia.

It is now clearly established that, as was illustrated in my lecture, the "alkaline reserve" may be, and often is, diminished in cases where the blood is abnormally alkaline; and conversely that the "alkaline reserve" may be increased where the blood is deficient in alkalinity. The expression "alkaline reserve" is an unfortunate one, in so far as it suggests the existence of a reserve of alkali beyond what is required to maintain a normal reaction. In actual fact the whole of the normal "alkaline reserve" of the blood is required to balance the carbonic acid normally present. When less or more carbonic acid than usual is present the "alkaline reserve" is gradually diminished or increased to such an extent as nearly to restore, if possible, the normal reaction. Conversely, if the "alkaline reserve" is increased or diminished the carbonic acid in the blood is, by diminution or increase of the breathing, so increased or diminished as, if possible, nearly to restore the reaction.

An instance of diminution in the carbonic acid of the blood, with consequent diminution in its "alkaline reserve," is furnished wherever increased breathing is caused by anoxaemia. An instance of diminution in "alkaline reserve," with consequent increased breathing and diminution in the carbonic acid in the blood, is afforded by any case in which acids accumulate abnormally in the blood. This occurs to an extreme extent in diabetic coma, of which the phenomena seem to me to point very clearly to a condition of extreme acidosis, along with secondary damage where the condition has lasted for some time, just as there is secondary damage when anoxaemia has lasted for some time.

For "alkaline reserve" one might substitute some such expression as "CO₂-combining capacity"; but probably the more picturesque expression "alkaline reserve" will survive, as it is now so extensively used. To define acidosis or alkalosis as diminution or increase in "alkaline reserve" is, however, so definitely misleading that I feel sure that such a definition ought to be avoided. Acidosis and alkalosis are extremely small, but also extremely important, deviations from normal in the hydrogen ion concentration within the body. The available direct physical and chemical methods are still too rough to

enable us to follow these deviations closely; but we can do so by the far more delicate method of observing the accompanying changes in breathing and in the excretion of acid or alkali and ammonia by the kidneys.—I am, etc.,
Oxford, April 3rd.

J. S. HALDANE.

CARDIAC PERISTALSIS AND MITRAL STENOSIS.

SIR,—In his thoughtful paper on "Cardiac peristalsis and mitral stenosis" Dr. Samways brings out an important fact in connexion with the mechanism of the heart beat—namely, that during the initial phase of closure the semilunar valves are supported by contracted ventricular muscle, and the auriculo-ventricular valves by contracted auricular muscle.

Some years ago I drew attention to the incompetence of the aortic semilunar valves to support the aortic blood pressure, emphasizing this incompetence by asking what would happen if a portion of the aortic wall were replaced by semilunar membrane. Obviously rupture would speedily ensue. I suggested that during the early phase of semilunar closure the ventricular wall adjacent to the valves remains contracted, thus affording the closed valves the needful support until such time as the rising intra-ventricular pressure is adequate for the purpose. This explanation has since been established as a fact. Presumably the same line of argument applies to the auriculo-ventricular valves, though the conditions in their case are somewhat different.

Curious that so glaring a fact as the incompetence of semilunar tissue to sustain for a century or more rhythmical pulsations of 100 Hg pressure should have escaped the physiologists. Modern textbooks on physiology still overlook it. Other essential truths in connexion with the circulation are similarly neglected. Indeed, I make bold to assert (what may perhaps shock, but I trust will not offend, the professed physiologist) that it is not possible to get a proper insight into the physiology of the circulation from any modern students' textbook of physiology—at least not from any I have consulted.

Here, for example, are a few among several fundamental points wholly ignored in these works, although an understanding of them is essential for a proper understanding of the circulation: the meaning of the great excess of the aortic over the pulmonary blood pressure (how comes it, for example, that the aortic pressure of the mouse is greater than the pulmonary pressure of the horse?); the object of the muscle tissue in the aorta and other large blood vessels and in the veins; its abundance in the veins of the lower limbs; its scantiness in the veins of the neck and its entire absence in the intracranial, interosseous, and intraocular veins.—I am, etc.,

London, April 3rd.

HARRY CAMPBELL.

THE FUTURE OF RESEARCH IN TROPICAL MEDICINE.

SIR,—I much regret if in my recent address I have done any injustice to the Committee for the Prevention of Tropical Diseases through inadvertently using the word "island" in the singular instead of the plural, although it in no way affects the principle for which I was contending—namely, that the time has come for a further advance in the way of establishing more permanent research laboratories in British tropical possessions rather than in sending out further expensive temporary expeditions.

I am surprised at Dr. Jensen's statement that I should have been welcomed at his committee's meetings, considering I received no notice of them, and in view of the fact that I have waited in vain for six months for any reply to my letter to him setting forth the views I expressed in my recent address and offering to join the committee if at any time they adopted the policy I advocated. As a matter of fact, one of the two copies of the circular he sent me was not marked "proof" or in any way as confidential, while judging from the long list of members of the committee, scattered all over the world, to whom it had presumably been sent, it never occurred to me that the committee did not think it wise to allow their policy to see the light of day. The decision as to which is now the better policy may safely be left to the real arbiters—the holders of the purse-strings.—I am, etc.,

London, W., April 4th

LEONARD ROGERS.

THE COLLECTIVE OPINION OF THE PROFESSION.

SIR,—I should like to support the letter of Dr. Fothergill in this matter (*BRITISH MEDICAL JOURNAL*, March 5th, p. 362), and hope that the Council will accept and act upon the suggestion of a questionnaire. I especially want to see the formation of a committee of medical men who should represent the views of the medical profession and the medical profession alone, and one which should not profess to promote the interests of the community rather than those of the medical practitioners engaged in active practice. If the large number of medical men at present outside the British Medical Association could only be convinced that these two objects could be attained, I feel sure that the Association would soon be invincible and absolutely beyond the caprice of bureaucracy.—I am, etc.,

S. NOY SCOTT.

Plymstock, S. Devon, March 28th.

EVOLUTION IN RELATION TO DISEASE.

SIR,—Your first leader in the issue of the *BRITISH MEDICAL JOURNAL* of March 19th, on the new epidemiology, induces me to write the following remarks. In a contribution to the Epidemiological Society of London on March 16th, 1906, on the above subject, I opened with the statement that

"there are times when it is essential for real progressive knowledge that we should pause and contemplate the discoveries already made and the knowledge already achieved. The pure scientist is by nature cautious—so cautious, indeed, that if he alone were to deal with the problems of science progress would naturally be slow. Many a biologist has looked at but not recognized under his microscope some organism of high importance which later has been readily perceived by a more philosophical observer who has allowed analogy and deduction to influence his researches."

When I read a paper on "The evolution of disease and disease germs" at a Public Health Congress at Eastbourne in July, 1901, a well-known medical officer of health—who subsequently achieved the highest distinction—denounced my deductions as "dangerous." (His latest writings reveal that he is a convert.) Another well-known medical officer of health stigmatized my suggestions as "absurd." At that time I advanced my arguments as the results of my own bacteriological observations and cogitations thereon when demonstrator of bacteriology at King's College, University of London, and was unaware of any previous philosophical reasoning on the subject. But I shortly afterwards learned that I was in good company—both as regards the thesis I advanced and the sarcasm and antagonism with which it was received—in the person of Sir William Collins, who had enunciated similar views in a letter to the *Lancet* of May 14th, 1881, which had been ridiculed even by the medical press. My contribution to the Epidemiological Society in 1906 met with a kinder reception, and gave rise to a valuable discussion opened by the late Dr. Payne, whose reputation as a scientific pathologist was well founded. Those interested in evolutionary pathology will find in his remarks a most entertaining and picturesque application of the Darwinian system to disease processes.¹ Only so recently as last year Sir William Collins contributed a historical retrospect on "Specificity and evolution in disease," dating back to his original letter of May 14th, 1881.²

In the course of the discussion on my paper in 1906 Dr. W. H. Hamer, remarking that, while my views were somewhat unorthodox, I had submitted my thesis to a tribunal likely to give it careful and sympathetic consideration, did great service in reviewing previous evidence of interest on the part of members of the Epidemiological Society on the relationship between scarlet fever and diphtheria, such interest dating back to remarks by Dr. Burdon-Sanderson in 1858-59, when a Diphtheria Subcommittee was appointed. A point specially considered by this committee was the extent to which epidemics of diphtheria had been coincident in place and time with epidemics of scarlet fever. Dr. Ransome, in 1875, attached importance to two points as showing that diphtheria and scarlet fever were not identical—one of his objections was that, whereas scarlet fever was milk-borne, diphtheria was not; the other was that diphtheria was commonly spread by

sewer air, not so scarlet fever. Both objections are now anachronisms.

In my paper I devoted especial attention to the bacteriological side of the problem, commenting on the frequent association of streptococci, Hoffmann's bacilli, and Klebs-Loeffler bacilli in the swabbings of throats from both scarlet fever and diphtheria patients, and I still hold the view, as suggested in the *BRITISH MEDICAL JOURNAL*, 1902, vol. i, p. 56, that these organisms, thought by many to be well-defined "species," are interchangeable varieties in the life-history of a common saprophytic organism which has passed through evolutionary phases on different lines, giving rise under certain conditions to an organism which, in susceptible persons, brings about reactions recognizable in the form of a clinical entity known as scarlet fever; while under other evolutionary conditions the organism becomes what is known as Klebs-Loeffler bacillus, with reactions in susceptible persons inducing a clinical entity recognizable as diphtheria. But betwixt definite scarlet fever and definite diphtheria are many less definite clinical conditions; many of these are associated with what is known as Hoffmann's bacillus. In the later stages of both scarlet fever and of diphtheria Hoffmann's bacillus is frequently found as the principal organism in throat swabs. I have observed elements in a chain of streptococci assuming bacillary forms. Once again I repeat what I said in 1902: "True scientific instinct should bear in mind the perturbing influences of evolutionary factors in disease." I cannot here more than mention the probabilities of a common ancestral stock for puerperal fever, erysipelas, rheumatic fever, scarlet fever, and diphtheria; or of a similar common ancestral saprophytic original organism for the various typho-coli races of bacteria and their resulting fevers; or of another for measles, small-pox, alastrim, varicella, and vaccinia.

In addition to the bacteriological side there are sides of the problem both important and interesting, such as the epidemiological relationship which Dr. Longstaffe pointed out between seasons of drought and scarlet fever, diphtheria, etc. It is now known that both diseases may be spread by milk and school attendance, and in both diseases "return" cases are not infrequent.

In my reply to the discussion on my paper in 1906 I laid stress on the importance of symbiotic relationship in individual throats; in some favourable, in others inimical to the evolution of function and even of morphology. Such can be studied only by sustained observation of cultures made from *daily* swabs of the particular throat in question. This was my special method of observation, having a fever hospital and bacteriological laboratory at command. The only likely method of demonstrating such observations to others would be by calling in the aid of photomicrography.

Now that evolutionary pathology appears to be coming into its kingdom it is appropriate once again to draw attention to the monumental and hitherto unaccepted scientific work of the late Dr. Charlton Bastian dealing with archebiosis and heterogenesis. It is highly probable that all bacteria are merely stages in the extremely complicated cycle of low forms of life.

How history repeats itself, even in the advancement of human knowledge, may be realized by a careful re-perusal of Darwin's historical sketch of the progress of opinion on the origin of species previously to the publication of the first edition of his celebrated work. Thus we may go back a hundred years to find the real pioneers of evolutionary pathology, and to learn that even then thoughtful men had been forced to the conclusion that "species are only a higher and more permanent (or stable) class of varieties." How seldom can lowly bacteria achieve and maintain such permanency! How extremely probable that therefore there should be such variation in disease—sometimes malignant, at others so mild as to create doubt whether the epidemic illness prevalent is to be called scarlet fever, or influenza, or Dunn's disease, or "fourth disease," or "new disease."

The publication of my book on *Evolution and Disease* brought me copies of interesting and instructive papers by distinguished American authors. Among others, one on variation in type of infectious disease as shown by the history of small-pox in the United States, 1895-1912, by Charles V. Chapin.³ The evidence pointed to the existence

¹ *Transactions of the Epidemiological Society of London*, vol. xxv, 1905-1906, p. 251.

² *Lancet*, 1920, i, p. 1059.

³ *Journal of Infectious Diseases*, September, 1913.

in North America during this period of two distinct strains of small-pox, both tending to breed true, though it was possible that a few outbreaks of the severe type may have developed from the mild type which received a great variety of names—Cuban itch, army itch, bean itch, rhobie itch, cedar itch, African itch, Spanish measles, Japanese measles, bean-pox, water-pox, etc. A similar mild type of small-pox in England occurred in 1919. Of a more speculative nature is the highly interesting presidential address to the Connecticut State Medical Society, delivered by Dr. Stephen J. Maher in May, 1915.—I am, etc.,

Norwich, March 31st.

J. T. C. NASH.

BOVINE TUBERCULOSIS.

SIR,—At a recent discussion of the Royal Society of Medicine on the "Eradication of tuberculosis in man and animals," Professor Lyle Cummins is reported to have said he could not free his mind from feeling that it (partial vaccination by a bovine strain and prolongation of the disease in the class of case in which milk might be concerned, the middle-aged type, did exist, although he would regard the advocacy of such vaccination as entirely unjustifiable.

He would therefore, I imagine, believe that for this end to be attained bovine tuberculosis must have been on the increase during the past fifty years, the period in which human tuberculosis has shown such a marked decline. The opponents of the immunity theory would probably consider that bovine tuberculosis had also declined during this period, a supposition which seems just as probable as the other.

Are there any statistics in existence relating to the incidence of bovine tuberculosis during the past fifty years? I imagine not. If there were, they would be interesting with reference to the question of immunity. Infancy and childhood are the periods of life in which the largest quantities of milk are consumed, but until the present century these were the age periods in which, to quote the report of the Registrar-General, "the fall of mortality amongst young children has previously lagged somewhat behind those at most, and for females at all ages."

Childhood and the earlier adult years of life are also those in which the infectious illnesses mostly occur, and during these illnesses increased quantities of milk are taken. In these age periods also the non-pulmonary and bovine forms of tubercle are most prevalent.

The dose of bacilli in milk at any time must be x , but this being understood the following questions may be put. If this partial immunity exists, when does it begin to develop, when is it most potent, and when does it begin to decline? Surely it ought to be most potent in childhood and gradually become less dominant, yet Professor Lyle Cummins suggests that it has most influence in the middle-age type of disease, and not with the young adult type.

Whatever views may be held as to the benefit or danger of the consumption of tuberculous milk by children, I have never yet met anyone who suggested that the drinking of such milk by adults was an advantage to the consumer. If it were so, in the opinion of those who believe in partial immunity, it would be an argument against attempting to diminish the incidence of bovine tuberculosis.—I am, etc.,

Guernsey, March 29th.

H. D. BISHOP.

ADRENALINE IN RESUSCITATION.

SIR,—The valuable letter of Mr. Lockhart-Mummery on p. 190 of the JOURNAL on January 15th may appeal to more of us than he seems to think.

Surely he makes too much of his dilution of adrenaline to 1 in 50,000 before administration. Experimental physiologists have long recognized with regard to intravenous administration that dilution of drugs with the blood can be secured to any extent by slowness of injection. That Mr. Lockhart-Mummery found by his observations that 1 in 50,000 was the optimum dilution of adrenaline means no more than that it was the optimum at the rate at which he injected; no two operators would inject at the same rate and so secure the same dilution in the general circulation, however constant the contents of their syringes were.

The "person skilled in the use of adrenaline transfusion," the necessity for whose presence Mr. Lockhart-Mummery considers such a grave limitation of the scope of the procedure he advocates, need be no other than any one of us who is accustomed to using a 10 or 20 c.cm. syringe for intravenous medication.

It is this recognition that the blood is the best diluent that has changed the intravenous administration of quinine—for example, from being a procedure for those "skilled in transfusion" to being a matter of an intravenous injection easily within the competence of any tropical practitioner. Provided he takes the precaution of adding $m\gamma$ of liquor adrenalinii to his solution, and of injecting slowly, he can avoid the one danger of intravenous injection of quinine—that of a drop in the blood pressure. The tetanus spore, the bogey of the intramuscular method, he may leave to be dealt with by the leucocytes; and his patients never remind him of his intravenous injections of quinine as they did of his intramuscular ones, followed so often by painful lumps dotted about just the parts of the body they wanted to lie on.

Intravenous medication is still in its infancy. Used with discretion it has a great future before it; and it is a distinct encouragement to its use, when indicated, that it is the one way of giving medicine which demands no accuracy of dilution in dispensing. The practitioner has only to judge, say, how many grains of quinine or urotropin or how many minims of tincture of iodine he wishes to administer; he gives this in the nearest available syringe, without regard as to whether it be a 5 or a 10 c.cm. one, and in injecting he presses the piston very slowly, thus further diluting his drug with the most abundant, handy, cheap, and surely sterile saline solution he could use.

If Mr. Lockhart-Mummery, out of his experience, will tell us what is the dose of liq. adrenalinii hyd. (B.P.) to use in order to have the best chance of restarting a human heart that has stopped beating, we can do the rest.—I am, etc.,

J. L. MAJORIBANES, M.D., D.P.H.,
Lieut.-Colonel I.M.S.

Athen, March 15th.

IRRITABLE BLADDER.

SIR,—Dr. Hamilton, in the JOURNAL of March 26th, p. 480, asks for information with regard to modern methods of treatment of irritable bladder. In true "irritable bladder," which is associated with frequent micturition, pain, normal urine, painless and elastic bladder walls, faradism, as advocated by my father, the late Dr. Samuel Sloan of Glasgow, gives most satisfactory results.

I have employed this treatment according to my father's directions. "An intraterine bipolar electrode is introduced into the bladder with the usual antiseptic precautions. The current is taken from the secondary coil, the sedative form of current being thus employed." A dose of 2 to 3 milliampères for fifteen minutes, given on alternate days for ten or twelve treatments, will suffice for cases of irritable bladder, but a second course of treatment may be necessary in those cases associated with injury to the bladder from pressure during parturition, with paresis of the sphincter.—I am, etc.,

London, W., April 4th. ELIZABETH SLOAN CHESSEY, M.D.

CHRONIC RETENTION OF URINE ARISING FROM PROSTATIC DISORDER.

SIR,—In reply to Mr. Clayton-Jones (March 19th, p. 441), may I point out that my paper of March 12th dealt with the treatment of only one of the symptoms of prostatic disorder—namely, that of retention—and not of others which may arise from the same cause—for instance, nocturnal vesical irritation? In this case the affected glands within the prostate are so situated that they stimulate the area of reflex, thereby giving rise to a more frequent desire to micturate, though they are not as yet large enough to produce increased resistance in the prostatic urethra.

Nocturnal vesical irritation is often the forerunner of retention, though it is by no means a sure sign of its oncoming, for most men after middle life are more or less thus troubled, but, if tested, have no residual urine. Further, the symptom may, and often does, continue after retention has occurred. The desire to micturate is more

marked at night owing, I believe, to the fact that during the day, while volition is present, the slight irritation is either disregarded or inhibited, but when volition is withdrawn during sleep, or as sleep approaches, the excitant is exaggerated and is then sufficient to make the act imperative. Again, if the diseased glands do not interfere with the area of reflex a condition is produced which has been aptly described by Thomson Walker as "the silent prostate." The patient has few complaints and hardly any symptoms, but on investigation prostatic resistance is found to be increased, and there are many ounces of residual urine.

Nocturnal vesical irritation, although commonly associated with retention, does not necessarily imply that it exists; nor does the presence of this irritation negative the contention that "prostatic resistance is generally augmented by enlargement."

A patient complaining of nocturnal frequency and other defects, such as dribbling stream, urgency, and hesitancy, should be subjected to a systematic examination to ascertain the cause of the trouble. The only way of determining the presence of residual urine is by introducing a catheter immediately after the patient has passed all he can by his own efforts. The treatment afterwards is based on the condition found. With adequate precautions the risk of infection is exceedingly small; neither do I agree that a "breakdown" must almost certainly follow instrumentation performed by the patient himself for the purpose of treatment. It will not occur if he is taught to use the instrument properly, and is instructed in the details of an efficient and easy method of sterilization.

Finally, inducing the desire to micturate while the catheter is *in situ* will not produce any back pressure on the kidneys, mainly because the ureteric openings are firmly closed during vesical contraction, unless the disease is advanced and serious structural changes have already taken place, when the treatment would be worse than useless; and secondly, because the presence of the instrument reduces the prostatic resistance sufficiently to enable the muscle to deal with a normal load in a natural way, and at the same time prevents any undue pressure being put on the bladder.—I am, etc.,

London, W., March 30th.

HERBERT T. HERRING.

PROSTATIC SYMPTOMS AND THEIR CAUSES.

SIR,—I have been reading with much interest the recent contributions that have appeared in the *JOURNAL* on the troubles and symptoms of the enlarged prostate, and my interest is largely personal, as I have been for several years a sufferer from these myself. One's attention is naturally specially drawn to one's self when suffering, and occasionally new light may be shed and benefit derived by acting on the knowledge gained by introspection—*γνώθι σεαυτόν*. I am therefore glad to submit a few particulars of my own case.

I am 63, wiry, active, and, apart from bladder trouble, enjoying good health. But for ten or more years I have had symptoms usually regarded as entirely due to prostatic enlargement—mild at first, afterwards more pronounced. My prostate is moderately enlarged and elastic to touch. The capacity of the bladder is still up to 10 oz. The symptoms of my trouble are or were: Frequency of micturition, sudden urgency going on to incontinence if opportunity of relieving myself was not available. The stream was usually small and hesitancy in starting it not unusual—that is, some retention. I felt I would have greater relief if I could pass more urine after the flow had ceased. I often had pain at the end of the penis and in the perineum, radiating to adjacent parts of the thighs. Further, I was troubled with a very unusual symptom—namely, priapism. This came on generally during sleep as the bladder filled up, but subsided at once when the bladder was emptied.

Careful consideration of these symptoms has enabled me to realize that the prostatic enlargement, although a contributing factor, was not their main cause. The trouble I found was largely due to avoidable cause or causes, and after these were recognized and corrected I have felt better in every way, although I fear that as they have been operating to my detriment for a number of years unrecognized, permanent harm has resulted. Still, I am very much improved; of that there is no doubt. The

reaction of my urine, now normal, had been generally alkaline for a number of years, and this, in conjunction with the symptoms, I regarded as due to residual retention from prostatic enlargement. But now I know this was not the cause of the alkalinity. To explain: I may say I have been troubled with constipation for many years, and, like many others, got into the habit of obtaining relief by taking salines two or three times a week—generally seidlitz powders—with the result that the urine was markedly affected thereby, and became almost constantly alkaline in reaction. These salines, of course, give up their citrates or tartrates and become carbonates and phosphates. I find "phosphaturia" always appears after taking these salines. When such aperients are taken only occasionally no harm is done, as the effect soon passes away, but when taken habitually two or three times a week, as I used to, a marked effect is produced. The sensitive lining of the urinary passages, which in normal conditions is in contact with slightly acid urine, has to submit to the presence of a fluid of unnatural reaction and of irritating character, resulting in a slow inflammatory process, with thickening of the mucous membrane and subjacent tissues, including the prostate, which hypertrophies. Hence the explanation of most of my symptoms—the pain, sudden call, small stream, etc. The lumen of the passage of the urethra is small owing to tumefied mucous membrane and subjacent changes. I may add I have often seen stricture of the urethra, especially near the meatus, in elderly people with prostatic symptoms. As to the priapism, this is not so easily explained. It only appears when cerebral control is cut off, and only then when the bladder is distended. Priapism is seen occasionally in the newly born child and may last for weeks, causing distress to mother as well as child, and afterwards cease to trouble. Where death of the infant has occurred from other causes and a *post-mortem* examination made the only pathological finding in the genito-urinary system has been a deposit of uric acid concretions on the apices of the pyramids of the kidney—the so-called infarcts. What the association of these is with priapism, if any, I will not attempt to say. As to the causation of the symptom in my case it may be reasonable to infer that some similar process has been at work; it may be that deposits of uric acid or of alkaline salts, or both of these, was the cause of the trouble, but this is mere surmise. I should say I have no symptoms of tabes or other spinal cord disease.

I have been anxious to give the history of my troubles to your readers after reading the articles you have recently published, as it is likely that many other sufferers from what is usually regarded as simple prostatic enlargement are unconsciously responsible for their production.—I am, etc.,

March 27th.

SENECTUS.

ANGIO-NEUROTIC OEDEMA.

SIR,—Dr. Davis (p. 480) thinks me unduly pessimistic with regard to prognosis, but the impression I wished to give was that the tendency always remains, and that therefore recurrences are the rule, but they are apt to assume an attenuated form, so that to this extent Dr. Davis may take heart. In my experience, in the large majority of cases, the first series of invasions are the most severe, and of the most serious variety; for instance, those few cases I have seen in which the larynx has been involved have invariably occurred in the period of first invasion, recurrences of the disorder having been distributed in the superficial loose cellular tissues. The same remark applies to affection of the tongue. The first attack was by far the worst, subsequent attacks involving small areas only. Extremely uncomfortable, not to say painful, symptoms accompany the disease in its internal manifestations. A surgeon once told me that twice he began to operate upon patients for acute appendicitis only to find that angio-neurotic oedema of the gut was entirely responsible for the symptoms. When the oesophagus is implicated the condition is one of the utmost discomfort, and is apt to create alarm. It is remarkable that sometimes a series of cases occurs in which the mouth and throat are almost exclusively involved, and another series in which the subcutaneous tissue is attacked. There appears to be no reason for this beyond the relative

susceptibility of the patient. In those liable to angio-neurotic oedema the presence of a fly, or even of a particle of dust, in the eye will at once bring on the trouble.

If Dr. Davis will read Dr. Francis Hare's article upon the "Paroxysmal neuroses," in the February number of the *Practitioner*, 1906, he will probably find much help in its application to this condition. Dr. Edgeworth of Bristol has also contributed an interesting paper upon the subject (*Quarterly Journal of Medicine*, January, 1909, vol. 2, No. 6), and in a memorandum to the *Lancet*, June 2nd, 1906, I have tried to point out how Dr. Hare's remarks apply to the disorder, and, in view of my subsequent experience, I am more than ever convinced that the failure of the decarbonizing functions is chiefly responsible. Many incomplete cases occur, and are apt to be overlooked, so that, possibly, the disease is not so rare as is generally supposed.

I believe it is a well-known fact that an access of pyrexia banishes epileptic fits for a time. I have observed precisely the same incident in the course of angio-neurotic oedema. This may point to a relation between the two, or simply to a common origin in variations in carbonaceous income and expenditure with differing results. If, however, both diseases were found to be more closely related than is apparent, we might have to modify our point of view in the treatment of the major disease.—I am, etc.,

Exeter, March 29th.

CLAUDE A. P. TRUMAN.

GLANDULAR FEVER.

SIR,—The account of glandular fever in your issue of March 26th, p. 452, is interesting. It seems to be a very definite disease with well-marked clinical features. I have lately had a case in my own family.

The patient, a boy aged 4½ years, was strong and healthy up to a little time before Christmas, 1920, when he began to look pale and appeared out of sorts, and complained of easily getting tired. About January 16th he looked flushed in the evening, but no temperature developed. The same thing occurred the next evening. On the next morning his temperature was 100.4, and he had some headache and he remained in bed. Next day the temperature rose to 101.4°, when a swelling was noticed under the middle of the right sterno-mastoid muscle, and he complained of pain on moving his neck. A patchy erythematous rash developed, chiefly over the shins, and one or two patches on the arms, face and body. This lasted three or four days. The nose bled rather profusely once. The glands on the left side under the sterno-mastoid then swelled up, but not so markedly as on the right side. The temperature ranged between 101° and 103°, but came down fairly rapidly to normal about the tenth day. During the illness constipation was rather marked. The pulse seemed quick, out of all proportion to the temperature, going up to 150 at the height of the fever, and being very irregular in force and rhythm, and the child looked and seemed very ill. Examination of the throat showed redness of the fauces but no enlargement of the tonsils. Unfortunately a swab was not obtainable, as the child resented having his mouth opened. The swelling of the glands lasted about ten days.

After the temperature had come down to normal the child was kept in bed a further ten days and on a sofa for a further fortnight, until the heart had settled down. Examination of the heart did not show any signs of dilatation, so the rapid pulse was probably due to a toxæmia.

Treatment consisted of glycerin and belladonna to the glands and a febrifuge mixture at first, followed by quinine and small doses of digitalis and strychnine. During convalescence cod-liver oil and malt and Parrish's food were given.

The child now looks well, but care is still exercised that he does not do too much. His brother, aged 6½ years, was in and out of his room during the illness, but did not develop anything, so possibly the disease is not very infectious.

For some time before the illness I had attended several cases of adenitis in children, but they were of the ordinary type, with sore throats and infection of the glands of the anterior triangle.

The theory that the infection may be a type of influenza may have something in it, for shortly after his illness a very widespread outbreak of influenza, beginning amongst the elementary school children, developed here and is still going on, and a large number of cases of bronchopneumonia have occurred.—I am, etc.,

Chichester, March 28th.

WALTER DICK.

THE Swedish Government has allotted 5,000 crowns to the Swedish Medical Association to help in the printing of the three scientific journals published by the association.

Universities and Colleges.

UNIVERSITY OF LONDON.

A MEETING of the Senate was held on March 16th.

The title of Professor of Surgery of the University was conferred upon Mr. G. E. Gask (St. Bartholomew's Hospital) and the status and designation of appointed teacher were conferred upon Dr. T. R. Elliott, Professor of Medicine in the University. Dr. John A. Ryle was recognized as a teacher of medicine at Guy's Hospital Medical School.

The Royal Dental Hospital and London School of Dental Surgery and the National Dental Hospital and College, forming a department of University College Hospital Medical School, were continued as schools of the University (in dentistry only) for a period of one year, from January, 1921.

Professor A. D. Waller, F.R.S., was reappointed Director, and Dr. T. D. Lister, C.B.E., Treasurer of the Physiological Laboratory until the end of the session 1920-21.

It was resolved that the revised syllabus in pharmacology of the second examination for medical degrees, Part II (Red Book, 1920-21, pp. 247-9, and Blue Book, September, 1920, pp. 229-31) be operative in and after the year 1923.

The following were appointed to act as additional examiners in obstetric medicine at the M.B., B.S. examination in May, 1921: Dr. J. S. Fairbairn (St. Thomas's Hospital), Dr. T. G. Stevens (St. Mary's Hospital), or, failing either of these, Dr. E. Holland (London Hospital) or Lady Barrett, C.B.E. (Royal Free Hospital).

Mr. H. J. Waring has been reappointed by the Faculty of Medicine a member of the Senate for 1921-25.

Applications for the Jodrell Chair of Zoology and Comparative Anatomy tenable at University College (salary £800 a year) and the Chair of Anatomy tenable at St. Bartholomew's Hospital (salary £900 a year) must be received by the Academic Registrar by April 25th and April 14th respectively. Applications for a University Studentship in Physiology (£50 for one year) must be received by the Principal Officer, from whom full particulars can be obtained, by May 31st.

Course in Mental Deficiency.

A course of lectures on mental deficiency, arranged by the University Extension Board in co-operation with the Central Association for the Care of the Mentally Defective, will begin at the University of London, South Kensington, on Monday, May 23rd, and terminate on June 4th. It meets the requirements of the syllabus for the diploma of the University in psychological medicine. The course will consist of eleven lectures, with clinical demonstrations, on mental deficiency by Dr. A. F. Tredgold and five by Dr. F. C. Shrubbsall on administrative procedure in the ascertainment and treatment of the mentally defective, supplemented by lectures on the psychology of mentally defectives by Mr. Cyril Burt; on methods of training mentally defective children by Miss Lucy Fildes, on psychoneuroses in relation to mental deficiency by Dr. Eric Prideaux, and on the relation between crime and mental defect by Dr. W. C. Sullivan, medical superintendent of the Criminal Lunatic Asylum, Broadmoor. Further particulars can be obtained on application to Miss Evelyn Fox, at the University of London, Imperial Institute Road, South Kensington, S.W.7.

GUY'S HOSPITAL.

Dental Research Fellowship.

A Dental Research Fellowship Fund has been instituted, consisting of a sum of money not exceeding £300 per annum, awarded wholly or in part. Applicants, whether graduates or undergraduates, must have studied in the Medical School or Dental School of Guy's Hospital, unless the advisory body decides that the circumstances are exceptional. Holders of grants from the fund may, at the discretion of the advisory body, be part-time research workers. All research work undertaken with the aid of the fund must be entirely carried out in Guy's Hospital or the schools attached thereto, unless the advisory body agrees that, from the nature of the work, some portion of the study might with advantage be pursued elsewhere. Applications for grants from the fund should be made to the Clinical Research Committee of Guy's Hospital, London Bridge, S.E.1.

UNIVERSITY OF DURHAM.

At the Convocation held on March 26th the following degrees were conferred:

M.D. (for Practitioners of Fifteen Years' Standing).—C. Corfield,

R. J. C. Thompson.

M.S.—J. A. Berry, W. A. Hewitson, N. Hodgson.

M.B., B.S.—J. S. Clark, R. C. Davison, T. W. K. Duncombe, Norah

H. Hamilton, R. T. E. Naismith, J. D. Silverston, T. S. Severs.

H. Toma, R. P. Wanless.

B.S.—Margaret B. Herbst.

B.Hy. AND D.P.H.—W. L. Glegg.

UNIVERSITY OF EDINBURGH.

Department of Physiology.

THERE is a vacancy for an assistant in this department. Applications, with full information as to qualifications and previous work, should be addressed to Professor Sir E. Sharpey Schafer, from whom particulars of salary, nature of work, etc., may be obtained.

UNIVERSITY OF ABERDEEN.

A GRADUATION ceremony was held on March 31st, when the following medical degrees were conferred:

- M.D.—J. B. Milne.
 M.B., CH.B.—J. Craig, Eleanora M. P. Law, D. R. Macdonald, Mary M. Pyper, I. R. Spark, C. D. Allan, J. J. H. Anderson, N. C. Bodenstein, F. K. Chen, Lillian F. Gall, R. K. Grant, G. G. W. Hay, Margaret Lipp, M. H. Logg, A. MacKay, Elsie Mackie, Katharina F. E. van der Merwe, Mary G. Milne, Dorothy Mitchell, J. I. Moir, Marion E. Mowat, Isabella M. H. Murray, Janet C. Nicol, A. E. Reid, E. N. D. Repper, J. P. J. Rossonw, G. Saint, N. C. Simpson, Ethel V. G. Smith, A. L. G. Thomson, J. S. Thomson, A. R. Wood.
 D.P.H.—D. W. Berry, A. M. Dugan, F. A. Innes, H. R. Neilson, W. W. Nicol, J. A. Sellar, Agnes L. Semple.

* Passed Final Medical Professional Examination with distinction.
 † With second-class honours.

UNIVERSITY OF GLASGOW.

THE following candidates have been approved at the examinations indicated:

- M.B., CH.B. (*Medical Jurisprudence and Public Health*).—M. Brown, J. I. Cameron, J. A. Cameron, A. J. G. Caporn, W. Houston, T. J. Jones, D. Lamont, A. Logan, G. H. Macartney, W. M. McCash, J. W. McConville, F. McElwee, C. F. H. McFadyen, J. J. McGhee, T. J. McKail, E. J. MacPhail, W. B. McQueen, R. S. V. Marsball, W. Muir, A. Snaddon, J. Sneddon, W. A. McE. Stewart, H. V. Sweeney, D. M. Thompson, E. J. T. Thompson, A. F. White, A. Wilson, Marion C. Foyd, Mary D. A. Boyd, Jemina G. Brodie, Margaret G. Carrick, Katharine L. Couper, Elizabeth Compand, Isabella C. Darling, Martha D. Devon, Jean M. Gilechrist, Mary D. Gilmour, Annie W. Humble, Frances B. C. Livingston, Joan A. MacColl, Henrietta L. Paterson, Joanna T. Rae, Jessie G. Service, Jeanie M. Strathie, Eleanor M. Torrance, Adeline G. Vallance. *Old Regulations*: Francisco Ribeiro.

* With distinction.

UNIVERSITY OF DUBLIN.

TRINITY COLLEGE.

THE following candidates have been approved at the examinations indicated:

- FINAL M.B.: PART I.—*Materia Medica and Therapeutics, Jurisprudence and Hygiene, Pathology and Bacteriology*: L. Staznisky, A. E. Drotske, F. C. B. L. B. Crawford, D. S. Spence, J. V. Carroll, R. A. O'Meara, Minnie Alper, R. Seal, Charlotte A. Stuart, J. D. Watson, F. B. D'Arcy, Ruth Lenon, C. W. R. McCaldin, F. Malone-Barrett, P. H. S. Fonce, J. E. Deane, J. O'Connor, H. J. L. Morphy, M. Sayers, J. G. Russell, D. H. Saayman, Dorothy C. H. Dorman, Muriel V. Odlum, Mary H. Harcourt, L. Phillips, I. F. Myers, J. C. Byrne. *Materia Medica and Therapeutics, Jurisprudence and Hygiene*: H. Hall, W. T. Hogan. *Jurisprudence and Hygiene, Pathology and Bacteriology*: R. N. Perrott. *Pathology and Bacteriology*: A. G. Bewley, N. McI. Falkiner, A. E. Phillips, G. S. Moran, H. L. Hauna, H. C. Dundon, J. J. P. Kelly, J. Devane.

- PART II.—*Medicine*: J. A. Smith, D. J. Browne, R. H. J. M. Corbet, T. F. L. Cary, Elinor D. Stoford, H. C. C. Deane, Edith F. Willock, F. Y. Pratt, R. H. Satchwell, Dorothy A. Daly, C. S. Wilson, E. S. Horgan, Ruth F. Flavell, D. V. Latham, R. S. Chapman, J. A. Acheson, P. M. J. Bobbett, R. W. Power, T. W. Panter, J. D. Leahy, J. C. Davis, A. D. Ward, P. J. Healy, G. C. B. Robinson. *Surgery*: E. C. Smith, D. de Bruijn, R. V. Dowse, J. D. Leahy, H. C. C. Deane, W. H. Smith, Margareta T. Stevenson, Dorothy A. Daly, L. Herzenberg, R. S. Chapman, P. I. Levitt, G. C. Malherbe, P. J. Healy, C. W. Parr, J. A. Acheson, J. C. Brennan, F. M. Hilliard, Alida C. Burt, E. G. Campbell, Mary Horan, R. H. Satchwell. *Midwifery*: A. D. Ward, E. R. Murray, R. H. J. M. Corbet, M. R. Cooleican, Nannette Norris, A. H. N. Todd, L. Herzenberg, W. A. Murphy, R. Forner, J. D. Thompson, T. G. Warhain, Alida C. Burt, R. S. Chapman, Rita Dillon-Leetch, E. S. Horgan.

- D.P.H.: PART I.—*Chemistry, Bacteriology, Physics, and Meteorology*: T. J. KilBride, T. P. Chapman, T. D. Gordon, H. Muller. PART II.—*Sanitary Engineering, Sanitary Inspection and Report, Hygiene, Epidemiology, Vital Statistics, and Public Health Law*: T. J. KilBride, H. Muller, T. P. Chapman, T. D. Gordon, Anna M. K. O'Halloran.

Passed with high marks.

ROYAL COLLEGE OF PHYSICIANS OF IRELAND.

At a meeting of the President and Fellows, held on April 1st, the following candidates for the Fellowship of the College, who had been nominated on January 7th, 1921, were duly elected Fellows: Thomas Mather Thomson, Harold Pringle, M.D.

At the same meeting the successful candidates at the recent final examinations under the Conjoint Scheme of the Royal Colleges of Physicians and Surgeons, Ireland, were admitted Licentiate in Medicine and Midwifery of the College as follows: Mary Boland, Lucretia H. H. Byrne, T. Cooney, B. J. Coyne, J. A. Cusack, Edith M. L. Doid, A. C. Esmonde, P. Gaffney, S. A. Gailey, J. W. E. Graham, S. J. Halpin, T. J. Kerr, J. J. McHenry, P. Moylan, J. J. O'Sullivan, J. Tehan (with honours).

DR. CHACÓN, an eminent Spanish toxicologist and professor of obstetrics at the University of Madrid, has recently died.

In 1919-20 there were 14,088 medical students in the United States; this was an increase of 1,036 over the number in 1918. The number of students who became qualified in 1919-20 was 3,047.

Obituary.

RUTHERFOORD JOHN PYE-SMITH, CH.M., F.R.C.S.,
 Emeritus Professor of Surgery, University of Sheffield.

THE death of Mr. Rutherford Pye-Smith, which we announced briefly last week, will be felt as a personal loss, not only by the large circle of his friends, but by numbers of people of all ranks of society in Sheffield and district who have benefited by his professional skill or personal acts of kindness and sympathy. He was a worthy representative of a notable Sheffield family. His grandfather, John Pye-Smith, D.D., F.R.S., the eminent divine and geologist, left his native town in 1801 to settle in London; his father, Ebenezer Pye-Smith, F.R.C.S., was an honoured member of the medical profession, and it was in London that Rutherford John Pye-Smith was born in 1848. He and his elder brother, Philip Henry Pye-Smith, were educated at Guy's Hospital. The latter was the well known physician of Guy's, and editor of the first (posthumous) edition of Hilton Fagge's *Textbook of Medicine*, and editor and author of the subsequent edition.

Rutherford Pye-Smith took the diploma of M.R.C.S. in 1871 and that of L.R.C.P. in 1872; he became F.R.C.S. in 1875, and started practice in Sheffield in 1876. He was elected surgeon to the Sheffield Royal Hospital in 1877, and he devoted himself to the interests of that institution heart and soul. Although hampered by buildings and equipment that were then out of date and inadequate, he introduced Listerian surgery, and gradually effected a great improvement in the efficiency of the hospital on its surgical side. Though utterly incapable of advertising himself, and of a retiring and rather shy temperament, such abilities as his could not long remain unrecognized. He gradually won his way and took rank as one of the leading surgeons of the district. As an operator he was safe rather than brilliant. His technique was exceedingly careful and thorough, and his operative results were very good. As a clinician the accuracy of his observation and soundness of judgement were rarely at fault. He always kept in touch with the developments of surgery. One of the secrets of the success of his surgical work was that he was always hopeful and resourceful, however grave the case might appear. The amount of work he accomplished was extraordinary. His whole days were an unremitting round of toil, and a large part of the nights was spent in correspondence and literary labours. Everything he undertook was accomplished with untiring attention to the minutest detail. His activities included not only professional matters but various forms of social service, philanthropic and Church work, and in these he was much helped by the devoted assistance of his wife. He was never a rapid worker, and it was only by constant effort and exacting toil that he was able to get through the day's work and to satisfy his passion for accuracy and thoroughness.

After his retirement from the Royal Hospital staff in 1908, at the age of 60, he retained a large surgical consulting practice. He had been President of the Yorkshire Branch of the British Medical Association, and his Address in Surgery at the annual meeting of the Association in Sheffield in 1908 will be remembered by those who heard it as full of shrewd observation, mature wisdom, and humour. From the University of Sheffield he received the degree of Ch.M. in 1908; he was professor of surgery in that university, and represented it on the General Medical Council from 1911 to 1919.

In the strenuous days of the war his knowledge and skill were needed for the treatment of the sick and wounded. Though almost worn out by thirty-five years of incessant work and in poor health, he responded to the call and joined the staff of the Wharfedale War Hospital. The younger surgeons who were his colleagues at that hospital know well the value of the work he did there, as did his patients, by whom he was known as the saviour of limbs. But the strain proved too much for his years and a constitution never robust, and, though he continued to do valuable service until the end of the war, he was forced to yield to the remonstrances of his friends and to restrict the range of his activities.

When the strain of the war was over there was no hiding the fact that his health was very seriously under-

mined, though he would never consider himself an invalid. The restful life of his country home at Ampthill did something to restore his health; but the weakness remained, and he succumbed to heart failure following influenza after a brief illness of two days. His name must be added to the long list of veterans who sacrificed their lives by devotion to duty during the war.

His most striking characteristics, which endeared him to a large circle of friends, were a transparent sincerity in all he did and said, and a beautiful serenity of disposition. No one ever saw him ruffled or impatient. In all difficulties or controversies he was ready to act as mediator or to effect a compromise.

No notice of Rutherford Pyc-Smith can be complete without reference to his religion. His piety was entirely without aggressiveness, but no one who came in contact with him could doubt its sincerity and the influence exerted by religion on his every act and thought. It was manifest in his consideration for others, his modesty, his kindness and in his large-minded and large-hearted charity. His patients all loved him, and to few can it be given to inspire such entire confidence as he did. His memory will be gratefully cherished by numbers of people of all conditions.

ROBERT MURRAY LESLIE, M.A., M.D. EDIN.,
M.R.C.P. LOND.,

Physician to the Prince of Wales's Hospital, Tottenham, and the
Royal Hospital for Diseases of the Chest.

THE death, announced in our last issue, at the comparatively early age of 55, of Dr. R. Murray Leslie, will be keenly regretted by a wide circle of friends, medical and lay. It was unexpected, though for the past few months he had been in failing health.

Robert Murray Leslie came of an old Scottish Highland family, being the son of the late Alexander Leslie, J.P., of Suddie, Munloch, Ross-shire, and one of six brothers, four of whom became members of the medical profession. He received his schooling at George Watson's College, from which he passed to the University of Edinburgh, where he graduated M.A. in 1888, B.Sc. in 1889, and M.B. and C.M. in 1892—all with first-class honours. In science and in medicine he was the most distinguished graduate of his year, being awarded the Baxter and the Ettles Scholarships in these faculties respectively, and the University medal in medicine and obstetric medicine. After graduation he became house-physician to the late Sir Thomas Grainger Stewart at the Edinburgh Royal Infirmary, and, while Stark Scholar in clinical medicine, worked in the laboratory of the late Professor Greenfield, to whom he for a short time acted as assistant in the pathological department of the university. Soon afterwards he came to London, where he held many hospital and other medical posts, including a house-physicianship at Brompton and the senior medical registrarship at King's College Hospital. He became a member of the Royal College of Physicians of London in 1893, and in the following year was appointed assistant physician to the Royal Hospital for Diseases of the Chest. During his long connexion with the Prince of Wales's General Hospital at Tottenham he served also as lecturer in medicine at the North-East London Post-graduate College. His other activities included the chairmanship of Council of the Women's Imperial Health Association of Great Britain; he was an officer of the French Academy.

A colleague—"W. E. C. D."—writes: "At the time of his death Dr. Murray Leslie was senior physician to the Prince of Wales's Hospital, and had just resigned a similar position at the Royal Chest Hospital, City Road, the amalgamation of which with another hospital and the consequent loss of its traditions and identity as the oldest hospital for diseases of the chest in the world he keenly regretted. In the course of his career he made many contributions to medical literature, and had just completed a volume on *Pneumonia and its Modern Treatment* for Oxford Medical Press. He was widely recognized as a consultant upon diseases of the chest, and patients were sent to him for advice from all parts of the kingdom. Many of his brother practitioners and their patients and all of his hospital colleagues will miss his kindly, loyal, and generous personality. His services were ever freely at their disposal, as well as at that of members of the nursing profession, in the welfare of which he took a deep

and active interest. A few years ago Dr. Murray Leslie founded a medal in Edinburgh University, in honour of his mother, the idea being suggested by the fact that, of four of her sons who were members of the medical profession, three were graduates in medicine of the university."

Only last year Dr. Murray Leslie married Gwladys Olive, daughter of Captain Knox Keith, R.N., with whom deep sympathy is felt.

WE regret to record the death of Dr. GEORGE PHILLIP FRANCIS of Brecon, which took place on February 28th, after a protracted illness, at the age of 65 years. The son of the late Mr. Charles Francis of Venny-Fach, near Brecon, he was educated at St. Thomas's Hospital, and after qualifying in 1879 held a resident appointment at the City of London Hospital for Diseases of the Chest. He then went into private practice in Boston, Dorset, where he remained for some seven years, and in 1886 he bought an old-established practice in Brecon, South Wales, where he subsequently led a busy and successful life. He was honorary surgeon to the Brecon Infirmary, and held many other medical posts in the district. A member of the Brecon Town Council for some years he twice served as mayor, and, like his father before him, he was a justice of the peace for the borough and county. He was an ardent Freemason, a stalwart Conservative, and a keen member of the British Medical Association, having attended the annual meetings ever since he qualified. Dr. Francis was a man of varied interests, perhaps more fond of a good horse than of anything else, and he was well known as a breeder and exhibitor of Welsh cobs and hackneys. On many occasions he won first prizes at the principal horse shows in England and Wales, including a first at the London Hackney Show, for the best pair in a class open to the world, with the celebrated "Lady Dandy" and "Royalty." The strain of the extra work which he undertook during the war brought on acute dilatation of the heart early in 1919, and, although he resumed work some months later, he never quite recovered. He is survived by three sons, the second of whom, Captain Cyril Francis, R.A.M.C., is at present serving with the Army of Occupation in Germany.

Dr. CHARLES WEBB ILIFFE, coroner for Coventry and North Warwickshire, died on March 1st in his 77th year. He received his early education at the old Grammar School at Coventry, and subsequently studied for the medical profession at Middlesex Hospital. He took the diplomas of L.R.C.P. Edin. and M.R.C.S. Eng. in 1865. He was appointed coroner in 1879. For sixteen years he was surgeon to the Coventry and Warwickshire Hospital, afterwards becoming honorary consulting surgeon. Last year he was appointed a Justice of the Peace for the City of Coventry.

The Services.

HONOURS.

TERRITORIAL DECORATION.

THE KING has conferred the Territorial Decoration upon the following medical officers:—*Army Medical Service*: Colonel Alexander D. Sharp, C.B., C.M.G. *Royal Army Medical Corps*: Lieut.-Colonel Thomas Donovan, 1st Welsh Field Ambulance; Lieut.-Colonel Alexander Callan, D.S.O., 2nd East Lancashire Field Ambulance; Lieut.-Colonel Richard W. Brimacombe, Home Counties (Casualty Clearing Station (ret.)); Major Leonard A. Avery, D.S.O., D.A.D.M.S., 54th (East Anglian) Division; Major John Owen, attached Lancashire Fortress R.E.; Major George Mackie, D.S.O., 1st South Midland Field Ambulance; Major Walter G. Paget, attached 4th Battalion The Queen's Regiment; Major Charles A. Spooner, 2nd London Sanitary Company.

DEATHS IN THE SERVICES.

DEPUTY INSPECTOR-GENERAL NICHOLAS THOMAS CONNOLLY, LL.D., R.N. (retired), died at St. Jean de Luz, France, on February 10th, aged 82. He took the L.R.C.S.I. in 1860, and, entering the navy soon after, became fleet surgeon on September 25th, 1883, and retired with the honorary rank of D.I.G. on February 11th, 1894. He served in East Africa in the campaign at Vitu in 1890, receiving the medal with a clasp. Lieut.-Colonel Edgar Beer Russell, Bengal Medical Service (retired), died on November 8th, the day after attaining the age of 72. He was the son of the late Rev. Edward Russell Wesleyan Church, of Bloxwich, Staffordshire, was educated at

Guy's, and took the diplomas of L.S.A. in 1870 and M.R.C.S. in 1872, also graduating as B.Sc. with honours, and M.B., in 1872, at London University. Entering the L.M.S. as assistant surgeon on March 30th, 1872, he became surgeon lieutenant-colonel after twenty years' service, and retired on August 27th, 1900. Almost the whole of his service was spent in civil employment, first in Assam and afterwards in Bengal, where, after various less important civil surgercies, he held the same post successively at Patna, 1890-92, Darjiling, 1892-94, and Dabha, 1894-96. In September, 1896, he was appointed professor of materia medica in the Calcutta Medical College, and second physician to the college hospital, holding the chair till his retirement. He was the author of a work on *Malaria and the Spleen*, published in 1880.

Medical News.

THE annual general meeting and dinner of the Cambridge Graduates' Medical Club will be held on Thursday, April 21st, at the Imperial Restaurant (Oddenino's), Regent Street, London, W., at 7.30 o'clock, with the President, Sir Humphry Rolleston, K.C.B., in the chair. Price of dinner, 12s. 6d., exclusive of wine. The honorary secretaries are Mr. R. Davies-Colley, C.M.G., 10, Devonshire Place, W.1, and Mr. W. H. C. Romanis, 8, Harley Street, W.1.

A MEETING of the Society of Medical Officers of Maternity and Child Welfare Centres will be held on Friday, April 15th, at 5.30 p.m., in the Central Committee Room, University College, Gower Street, London, W.C. when a paper will be read by Dr. Marion Cockerell entitled "Infant feeding after the ninth month." A discussion will follow. Members are invited to bring friends, provided that they are medical officers of centres.

MEMBERS of the medical boards, the medical referees and the medical staff of the Ministry of Pensions in the Ireland South Region, entertained Dr. D. A. Carruthers at Incheon on the occasion of his departure from the Region. He has held the position of Commissioner of Medical Services for the past two years. About forty members of the medical profession engaged in the various branches of work in the Ministry of Pensions in the Region were present. Drs. C. R. Kilkelly (in the chair), T. E. Rainsford, H. B. Beatty and R. J. Rowlette each expressed the esteem in which Dr. Carruthers was held by the various departments over whose work he has presided, and referred to the invariable courtesy and consideration displayed by him towards all sections of the medical profession who came into contact with him. A presentation and address subscribed by seventy medical men was made in token of the universal regret felt on the departure of Dr. Carruthers from Ireland, and of the good wishes for his future prosperity in his new sphere of work in England. A presentation has also been made to Dr. Carruthers on behalf of the clerical staff of the Medical Services Branch.

A MEETING of the Harveian Society will be held at the Town Hall, Harrow Road, Paddington, on Thursday, April 14th, at 8.30 p.m., when Mr. Duncan Fitzwilliams, F.R.C.S., will read a paper on "The naevi of children and their treatment."

A SPECIAL course of instruction in venereal diseases for post-graduates and students will be given at the London Lock Hospitals commencing on April 18th and terminating on May 10th. The course consists of clinics daily and twenty-five lectures, three of which will be given at the Female Hospital, Harrow Road, and the remainder at the Male Hospital, Dean Street, W. The fee for the complete course is 4 guineas. Applications for tickets should be made to the Secretary at the Hospital, 283, Harrow Road, W.9.

ON March 29th Dr. John Jeffrey of Jedburgh was presented by his patients and friends with an illuminated address and three valuable pieces of Georgian silver on the occasion of his leaving the town to take up an appointment at Aberdeen under the Ministry of Health.

THE annual meeting of the Chartered Society of Massage and Medical Gymnastics will be held on Saturday, April 16th, at 3 p.m., at the Armitage Hall, 224, Great Portland Street, W.1. The chair will be taken by Sir E. Cooper Perry, M.D.

A POST-GRADUATE course in hydrology, radiology, and physical therapy lasting for two months will be held in the course of the year at Naples. Particulars may be obtained from Professor Pio Marfori, Sant' Andrea delle Dame 21, Naples.

THE late Sir John W. Byers, Professor of Midwifery in Queen's University, Belfast, left £51,068.

DR. A. F. NANKIVELL, on his retirement from the posts of medical officer of health and school medical officer for Poole, has been presented by the staffs of the health and education departments and of the Alderney Isolation Hospital with an inscribed clock, as a mark of their esteem and respect.

AT the meeting of the Medico-Legal Society, to be held at 11, Chandos Street, W.1, on Tuesday, April 19th, at 8.30 p.m., a paper will be read by Mr. W. G. H. Cook, LL.D., on "The liability of the insane in respect of civil wrongs."

THE King has appointed Colonel Sir Edward Scott Worthington, K.C.V.O., C.B., C.M.G., to be a Companion of the Order of the Indian Empire, for services rendered in connexion with the visit of H.R.H. the Duke of Connaught to India.

A SPECIAL course on the pathology and clinical aspects of tuberculosis will be held at Genoa from April 18th to May 21st. Admission to the course can be obtained on application to the Secretary of the Medical Clinic, Via Bailla 5, Genoa.

THE Coroner for the City of London, Dr. F. J. Waldo, held, during the year 1920, 599 inquiries in the City of London, including H.M. Prison at Holloway and the borough of Southwark. With the exception of a few natural deaths juries were summoned in all cases, Dr. Waldo holding that an intelligent jury, directed by a coroner, is a more satisfactory tribunal for the elucidation of truth than a coroner sitting alone. An inquest was held on the body of only one infant accidentally suffocated whilst in bed with its parents—the lowest figure ever recorded. The marked general decrease throughout England and Wales during the past few years in this class of preventable death is, Dr. Waldo thinks, due chiefly to the more general use of cots and cradles, and the holding of more autopsies by which the actual cause of death is ascertained. Inquests were held in only eight cases in which sudden death was accelerated by the administration of anaesthetics for surgical operations. Of this number, three died in the City and five in Southwark.

Letters, Notes, and Answers.

As, owing to printing difficulties, the JOURNAL must be sent to press earlier than hitherto, it is essential that communications intended for the current issue should be received by the post on Tuesday, and lengthy documents on Monday.

ORIGINAL ARTICLES and LETTERS forwarded for publication are understood to be offered to the BRITISH MEDICAL JOURNAL alone unless the contrary be stated.

CORRESPONDENTS who wish notice to be taken of their communications should authenticate them with their names—of course not necessarily for publication.

AUTHORS desiring reprints of their articles published in the BRITISH MEDICAL JOURNAL are requested to communicate with the Office, 429, Strand, W.C.2, on receipt of proof.

In order to avoid delay, it is particularly requested that ALL letters on the editorial business of the JOURNAL be addressed to the Editor at the Office of the JOURNAL.

THE postal address of the BRITISH MEDICAL ASSOCIATION and BRITISH MEDICAL JOURNAL is 429, Strand, London, W.C.2. The telegraphic addresses are:

1. EDITOR of the BRITISH MEDICAL JOURNAL, *Ailology*, Westrand, London; telephone, 2630, Gerrard.
2. FINANCIAL SECRETARY AND BUSINESS MANAGER (Advertisements, etc.), *Articulate*, Westrand, London; telephone, 2630, Gerrard.
3. MEDICAL SECRETARY, *McLisecra*, Westrand, London; telephone, 2630, Gerrard. The address of the Irish Office of the British Medical Association is 16, South Frederick Street, Dublin (telegrams: *Bacillus, Dublin*); telephone, 4737, Dublin, and of the Scottish Office, 6, Rutland Square, Edinburgh (telegrams: *Associate, Edinburgh*); telephone, 4361, Central.

QUERIES AND ANSWERS.

INCOME TAX.

"X" asks: Should a medical man who retired from practice in September, 1917, be assessed on a three years' average for 1920-21, seeing that since retiring he has done only a little locumtenent work?

No. If "X" had retired from medical work altogether he would not have been assessable at all for 1918-19 or following years. If he sold his practice his successor was liable to account for tax on the full profits of the tax from September, 1917, onwards, and no doubt did so. In any case, however, it seems clear that from that time our correspondent's income tax liability ceased to have any reference to the profits of his former practice, and that a new basis of liability was set up when he commenced locumtenent work.

"COLONIAL" inquires as to deductions for (1) "the primary cost of necessary instruments, etc." and (2) "part of the rent of a house a room of which is occasionally used for work."

(1) The cost of the primary or original equipment cannot be deducted; that cost represents an outlay of capital and only expenditure incurred to maintain the equipment is deductible. (2) "Colonial" can deduct a reasonable proportion of the rent he pays; what that proportion would be would, of course, depend on the particular circumstances.

"T. M. P." is selling a 1919 Ford car and a 1920 motor cycle for £275 and purchasing a new car for £600. He inquires whether he can claim an allowance of the difference.

As an expense of renewing his means of locomotion our correspondent is entitled to a deduction equivalent to the excess over £275 of the cost price, as on the day he purchased the £600 car, of a 1919 Ford and a 1920 motor cycle of similar make and power.

"BASUTOLAND" inquires what would be the position if his wife came to reside in England.

She would be liable to account for tax—after deduction of £225 and the allowances for children—on (a) her own income and (b) such portion of our correspondent's income from property (not from earnings) as he remitted to this country. In any financial year in which he is in this country, he would have to account for tax on one-third of the amount of the remittances made by him from earnings in the previous three years. The rates of tax are 3s. in the £ on the first £225 of taxable income and 6s. in the £ on the balance.

PAIN IN THE SHINS.

"W. M. J." desires suggestions for the diagnosis and treatment of a case under his care. The patient is a man of 55, who has suffered on and off for some twenty years past from aching pain in the shins at the junction of the tendinous and muscular portions of the exterior muscles of the leg. The pain usually comes on in one leg or the other after three or four hours in bed and awakens him from sleep. The skin over the affected area is cold to the touch. The patient is sparely built, but appears healthy and complains of nothing else. He takes a fair amount of walking exercise, wearing heavy boots and leggings. There is unquestionably no history of syphilis. I supposed that the condition was due to digestive disturbances and particularly to the use of acid fruit, etc., but am not clear if this is the case.

LETTERS, NOTES, ETC.

TRANSFIXION OF THE BODY.

DR. S. D. CLIPPINGDALE (London, W.) writes: The remarkable case now in Charing Cross Hospital—a man whose body was transfixied by a long metal rod (cleverly removed with the help of Mr. Venables, the hospital engineer)—is not without historic precedent. In the *London Hospital Gazette* for March, 1913, in a memoir of Sir William Blizard, I referred to a similar case which occurred about a century ago. A gentleman drove in a one-horse chaise from his office in the city to his home in Stratford. On arriving he found his groom absent, and had to unharness the horse himself. The horse, resenting the attention of a person to whose services he was not accustomed, became restive and impaled his owner to the stable door by driving one shaft of the chaise right through the chest. The local doctor, Mr. William Maiden, M.R.C.S., called in, sent for Sir William Blizard. Sir William, who practised long before the days of antiseptic surgery, was well aware of the danger of admitting atmospheric air into wounds, and advised the local surgeon to content himself with sawing off the projecting ends of the impaled shaft, and not attempt to remove it. This was done. The patient lived twelve years, and in gratitude for the action, or rather inaction, of his surgeon bequeathed his thorax with the shaft in it to the Museum of the Royal College of Surgeons. In the library of the college is a full account of the case by Mr. Maiden.

PUERPERAL INFECTION.

"M.D." (Lancs.) writes: It is a remarkable fact that when I get infection in any of my cases a certified midwife has invariably been in attendance; when the case has been attended by a woman neighbour the cases do well. Why is this? A midwife makes at least one examination, if not more; a neighbour does not make any. I find also that it is common for midwives to have patients with mild degrees of septicaemia, who recover without medical assistance. They hesitate to call in a doctor for two reasons: (1) It might convey to the minds of the relatives the midwife's incompetence, and (2) they dread a notification of puerperal fever. If the inspector of midwives would pay surprise visits and take the temperatures of all cases on the list of a midwife he or she would sometimes receive a shock.

ERADICATION OF TUBERCULOSIS IN MAN AND ANIMALS.

DR. A. A. WARREN (Paris), in the course of a letter on the report of the combined meeting of the Royal Society of Medicine and the Central Branch of the National Veterinary

Medical Association published in our issue of March 19th, writes: From Sir John McFadyean's remarks (p. 422) I gather that the eradication of tuberculosis from cattle would reduce to a vanishing point tuberculosis in other domesticated species, and appreciably reduce the incidence of tuberculosis in man, seeing that (Dr. A. C. Inman, p. 423) 18.7 per cent. of all cases are bovine infections and 85.7 per cent. of cases in children under five are of bovine origin. Sir John goes on to say that the eradication of tuberculosis would involve the slaughter of 750,000 cows or heifers, and that no Government would find the money to compensate for such a slaughter and the consequent diminution of the supply of (tuberculous?) milk. Rounding off the above figures a little, we may say, without undue exaggeration, that 25 per cent. of the tuberculosis in Great Britain is due to tuberculous cows and could be eradicated by their slaughter. Averaging the tuberculous cow or heifer at £10, we may conclude that, for lack of £7,500,000, one-quarter of that section of our population now doomed to tubercle, some 25,000 lives, mostly of infants, must be sacrificed, will be sacrificed this year, next year, every year. Easily satisfied, indeed, must we be if we accept Sir Clifford Allbutt's cold and paradoxical comfort that, after all, tuberculosis has brought us benefits in its train, and that our hope must lie in team work with comparative pathologists, and resign ourselves to his assurance that, in such a struggle, the public would bestow a relatively small sum for investigation and expect results in three months.

SIMULIUM REPTANS IN IRELAND.

DR. NINIAN M. FALKNER, Vice-President R.C.P.I. (Dublin), writes: Some time since I received from the late Dr. Cecil Digby of Knockane (on the banks of the river Laune), co. Kerry, a fly for identification, whose bite, he stated, produced severe inflammatory reactions in man and in animals. I forwarded the insect to Mr. J. H. Halbert, of the entomological department of the National Museum, who identified it as a specimen of *Simulium reptans*, described by Mr. Austen as one of the most dreaded of the blood-sucking Diptera. As the existence of this fly has only been recorded from a few Irish localities, some of which need verification, the foregoing may be of interest to your readers.

AN ACID DENTIFRICE.

DR. H. W. COLLIER (London, E.C.) writes to express his agreement with Dr. W. J. Henson's letter in the *JOURNAL* of March 12th, p. 403, regarding the injurious effects of the various alkaline dentifrices now in the market and the advantages of a fruit-acid toothpaste.

A DISCLAIMER.

We have received a note from Dr. R. L. Mackenzie Wallis and Dr. C. Langton Hower stating that articles which have recently appeared in the lay press, purporting to be abstracts of a paper recently read by them at the Royal Society of Medicine on a new anaesthetic, were published entirely without their knowledge and permission.

VACANCIES.

NOTIFICATIONS of offices vacant in universities, medical colleges, and of vacant resident and other appointments at hospitals, will be found at pages 31, 34, 35, 36, and 37 of our advertisement columns, and advertisements as to partnerships, assistantships, and locum tenencies at pages 32 and 33.

THE following vacant appointments of certifying factory surgeons are announced: Catwick (York, East Riding), Duntocher (Dumbarton), Eastbourne (Sussex), Sedgely (Stafford), Sherborne (Dorset), Stanford le Hope (Essex).

WE have received from Messrs. Watson and Sons (Electro-Medical, Limited), the latest issue of their *Sanic Record*, which contains a useful chart and table of spark-gap voltages, and also a bulletin on the use of duplitized film—that is, an x-ray film which has an emulsion coated on both sides and its manner of development. This firm has lately placed on the market a new x-ray plate in which an intensifying-screen material is combined with the emulsion so as greatly to reduce exposures.

SCALE OF CHARGES FOR ADVERTISEMENTS IN THE BRITISH MEDICAL JOURNAL.

	£	s.	d.
Six lines and under	0	9	0
Each additional line	0	1	6
Whole single column (three columns to page)	7	10	0
Half single column	3	15	0
Half page	10	0	0
Whole page	20	0	0

An average line contains six words.

All remittances by Post Office Orders must be made payable to the British Medical Association at the General Post Office, London. No responsibility will be accepted for any such remittance not so safeguarded.

Advertisements should be delivered, addressed to the Manager, 429, Strand, London, not later than the first post on Tuesday morning preceding publication, and, if not paid for at the time, should be accompanied by a reference.

NOTE.—It is against the rules of the Post Office to receive postage *retro-* letters addressed either in initials or numbers.

Oliver-Sharpes Lectures

ON THE NATURE OF FLUTTER AND FIBRILLATION OF THE AURICLE.

BY THOMAS LEWIS, M.D., F.R.C.P., F.R.S.

PHYSICIAN OF THE STAFF OF THE MEDICAL RESEARCH COUNCIL; PHYSICIAN TO UNIVERSITY COLLEGE HOSPITAL, LONDON; HONORARY CONSULTING PHYSICIAN TO THE MINISTRY OF PENSIONS.

LECTURE I.—AURICULAR FLUTTER.

MR. PRESIDENT,—May I first thank you, Sir, and the College which you represent for the honour you do me in appointing me to this lectureship—a lectureship founded to promote physiological research by observation and experiment and to encourage the application of physiological knowledge to the prevention and cure of disease; a lectureship founded to commemorate a great physiologist, and founded by a physician whose work in this very field is known to and admired by all of us.

The request which you have made, and which I have gratefully accepted, has come at a moment which to me is opportune. This lectureship carries with it a responsibility of no little weight; no lectureship could possess a more serious or far-seeing purpose than the welding together of Physiology and Experimental Medicine. I have said that for me the moment is opportune, for it comes at a time when observations in which I have been deeply interested for many years have grown to a state of some maturity. The observations of which I shall speak are essentially of a physiological kind; the investigations are reaching a point when their applicability to the practice of medicine cannot long remain in doubt. The subject chosen is the only subject which I could choose for these lectures: the work upon which my collaborators and myself have now been engaged for many years, a subject upon which we have been almost exclusively engaged during the past two years. These researches have comprised an attempt to solve the meaning of certain grave disturbances of the human heart beat, and it is my good fortune to be able to say to-day that we are at the end of this task. It is a long story, and, if it is to be told intelligibly in these two lectures, it must be told connectedly. With your permission I will try and place before you the leading facts

and arguments; I will narrate these, not in their historical order, but in the order most suited to my purpose, namely, to show you where our knowledge of auricular flutter and auricular fibrillation now stands. If I am to do this in the time at our disposal I shall be unable to bring before you anything but a small part of the evidence upon which our conclusions rest. Assuring you now that I shall draw no conclusion lightly nor without most closely weighing all the evidence, I must, from the force of circumstances, ask you to take much for granted. In another direction, also, and for similar reasons, I crave indulgence. It will be impossible for me suitably to bring into the compass of these lectures the names of many contributors to this field of knowledge. This historical aspect has been dealt with recently and fully in another place. In so far as I have myself contributed during the last two years, I have contributed with my immediate collaborators; we have worked as a team under the auspices of the Medical Research Council; the names of my co-workers are

Dr. Thomas Cotton and Dr. A. N. Inry of this country; Dr. H. S. Feil, Dr. W. D. Stroud, and Dr. H. A. Bulger of the United States, and Dr. C. C. Hiescu of Bucharest. From these introductory remarks I may proceed to my subject.

SOME NORMAL FEATURES OF THE CONTRACTION PROCESS.

Let me first briefly describe the relevant events when normal heart muscle contracts in response to a natural or artificial stimulus. The first event of which we possess knowledge is that it passes into what is termed the state of excitation. By this we mean that the muscle develops a charge, just as a battery develops a charge, and that currents flow through it and the surrounding tissues. The charge is such that the active muscle becomes relatively negative to that which is still inactive, in the sense that the sub-terminal of a copper-zinc battery is negative to the copper. These electrical changes, associated with muscular activity, are of sufficient magnitude to be recorded by means of sensitive instruments, and they yield the pictures now spoken of as electrocardiograms. The electrical change in the muscle is the immediate precursor of contraction: first the muscle becomes excited (or charged), secondly it contracts. The two events are separated in the mammalian auricle by a small time interval of three-hundredths of a second or less.

Now the process of excitation is not simultaneous in all parts of the muscle: it begins at the point first stimulated

*That the electrical change precedes the contraction is at the moment the accepted view, though the interval is acknowledged to be very short.

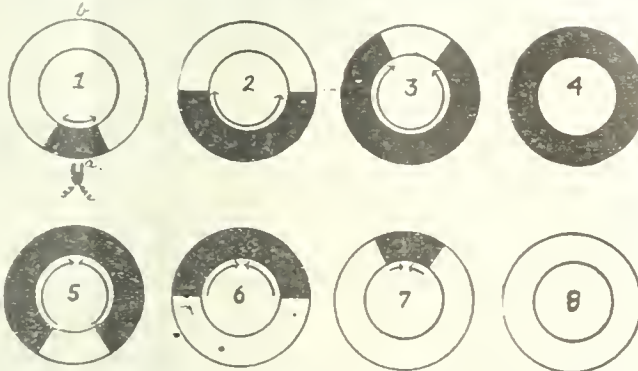

FIG. I.—A diagram illustrating the progress of a single wave passing through a ring of muscle as a result of stimulating it at a. The black portion of the ring represents the refractory state, and the figure shows its progress through the ring till it involves the whole (4); later the figure shows its subsidence.

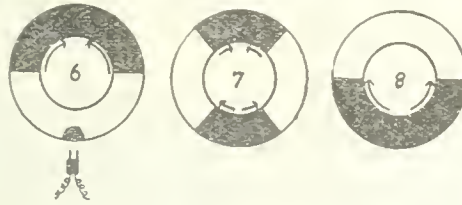

FIG. II.—A second stimulus enters the ring while it is in the condition shown in Fig. I. b. While the first wave is subsiding the second wave spreads.

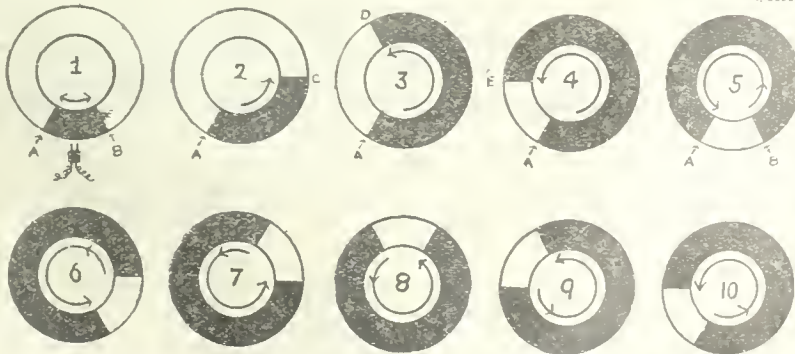

FIG. III.—A diagram to illustrate the establishment of a circus movement in a ring of muscle. The ring is stimulated in its lower quadrant, and the wave spreads to A and B. At A it is blocked, but from B it continues around the ring. When it arrives at B the refractory state at A is passing, and so the wave continues to travel around the circle C-D.

and spreads from this point. Stimulate a point in the centre of a sheet of muscle and the wave spreads concentrically, as does the ripple on the surface of a pond into which a pebble is thrown. It is conducted from one muscle element to the next as a wave, which is termed the *wave of excitation*. Similarly with the contraction process itself; this also spreads as a wave which accurately follows the course travelled by the wave of excitation. It may be likened to the second ripple on the pond. For our present purposes and to simplify the conception, we may regard these waves as one, signalling itself as it proceeds, first electrically (first ripple), then mechanically (second ripple). When, therefore, I speak of the wave of excitation in the auricle and of the course it takes, you may picture in your minds the wave of contraction without fear of serious misconception. Nevertheless, I should, perhaps, be guilty of inaccuracy if I spoke of the wave of contraction, because our studies have been mainly, though not exclusively, directed to the wave of excitation; for movements of the latter are to be recorded with far greater accuracy than movements of the former.

Movement of the excitation wave is recorded by connecting a sensitive galvanometer directly to the surface of the muscle. As the wave passes the chosen point, the galvanometer yields a sharp deflection, and this may be photographed and accurately timed against the events in some other region of the muscle. I do not propose in the present lectures to enter upon a detailed description of this delicate method, but am content to declare that we can time the arrival of this excitation wave at any point of the muscle surface with such accuracy that the error is no more, usually it is less, than one thousandth of a second; that by using two or more recording instruments simultaneously we can trace out the paths taken by waves of excitation as they travel through the muscle; and that we can estimate very accurately the time lost in the passage from point to point in different circumstances.

The wave of excitation, the first of the contraction process, travels until it involves the whole surface of the muscle; it travels in every available direction until it has exhausted all tracts of responsive muscle. Starting in the centre it travels until it comes to the boundaries; there it ends, for at the boundary it finds no further tracts of responsive muscle through which to pass. Appropriately you may liken the spread of the excitation wave to the flame of a prairie fire. It spreads concentrically wherever it finds inflammable material; it cannot return over its scorched wake, neither can it proceed when it reaches the bounds of the dried acres. The wave of excitation leaves the muscle over which it passes in a non-inflammable, or, as it is termed, *refractory state*, and that muscle is incapable of carrying a second wave of excitation until its original inflammable state is restored. The period during which this restoration is effected is

called the *refractory period* of the muscle; in the natural beating auricle of the dog it lasts from a fifth to a tenth of a second; its duration is approximately the same as the duration of the contracted state of the muscle.

From these preliminary observations I pass to what may be termed the "ring experiment."

THE RING EXPERIMENT.

The ring experiment was first performed by Mayer in 1908; he used the contractile bell of the jelly-fish and subsequently he utilized rings of muscle cut from the ventricles of turtles. His experiments were repeated and amplified by Mines in 1913 upon rings of muscle cut from the auricles of teleostean fishes. In 1914 both Mines and Garrey reported that they had obtained similar effects in rings of muscle cut from the dog's ventricle.

The experiment from our present standpoint is fundamental; I shall describe it, therefore, in some detail.

Suppose that we stimulate a ring of muscle, such as is depicted in Fig. 1, at a the centre point of its lowest quadrant.

At the instant of a single shock a wave of excitation. This wave, as soon as it has involved the whole cross section of the ring, develops two crests, which travel rapidly along the two limbs of the circle until, as shown in the serial diagrams (Fig. 1, 1-4), they meet at point *b*, the centre point of the highest quadrant. At the instant the crests meet the whole ring has become involved by the wave; the whole has passed into a state of excitation; it has all become "refractory." When, therefore, the two crests meet at point *b*, movement is

brought to an end; like two waves of flame, two waves of excitation meeting do not overlap, each crest forms an impassable barrier to the other. The ring of muscle remains in this state of excitation for a period and then recovers. It recovers in the order in which it has become involved, it begins to be "responsive" in its lowest quadrant (at *a*) first of all. The

wave of "responsiveness" travels similarly as two crests along the two limbs of the ring (Fig. 1, 5-8) until they also meet and coalesce at *b*, the centre of the highest quadrant. The ring of muscle has now returned to its original condition; it is once again wholly in the responsive state.

Such is the series of events when the muscle of the ring responds to a single stimulus. If the ring is stimulated by means of slow rhythmic shocks, each shock awakens a like series of events, providing that the intervals between the shocks are amply sufficient to permit recovery. Each stimulus yields a double-crested wave of response, which ultimately involves the whole ring. It will be evident that, if in rhythmic stimulation the second shock falls upon the ring while it is in the condition represented by Fig. 1, *a*, a fresh wave may be propagated at *a* before the response to the first shock has subsided at *b*. In such circumstances two waves will

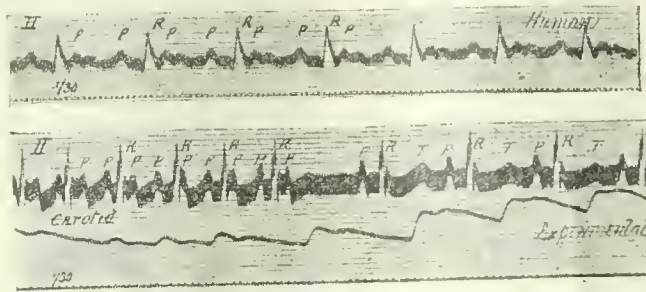

FIG. IV.—Examples of auricular flutter, clinical and experimental. The upper or clinical curve was taken from a patient in whom flutter was continuous. The auricle (P) is beating at a rate of 228 per minute and regularly; the ventricle (R) at half that rate. The ventricle responds to alternate beats of the auricle; the beat of the auricle to which there is no response falls with the beat of the ventricle. The lower or experimental curve shows the end of a period of flutter and the return of the normal rhythm. The first half of this curve is to be compared with the upper curve. During the period of flutter the auricle (P) is beating rapidly and regularly; the ventricle (R) at half the rate. The ventricle responds to alternate beats of the auricle; the beat of the auricle to which there is no response falls with the beat of the ventricle.

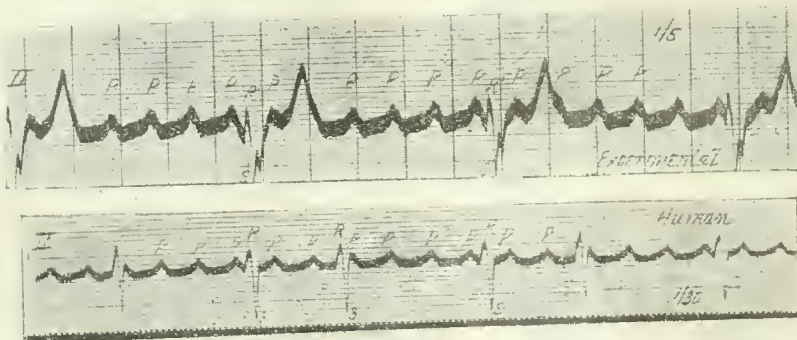

FIG. V.—Examples of auricular flutter, clinical and experimental. The upper or experimental curve was taken from a long period of experimental flutter. The auricle (P) is beating regularly and continuously at a rate of about 350 per minute; the ventricle (R S) is beating much more slowly. The lower curve is from a patient in whom flutter had persisted for many months. The auricle (P) is beating regularly and continuously at a rate of about 270 per minute; the ventricle (R S) is beating much more slowly.

be moving through the ring at one time, as depicted in Fig. II, 6-8.

We come now to a different form of reaction; it is that which especially concerns us. It happens when the rate of rhythmic stimulation is raised to a critical point—namely, when the intervals between the shocks are such that each falls on the muscle at a time when responsiveness in this muscle has not wholly recovered. In such circumstances the wave propagated by stimulation may be unable to travel with its usual freedom in all directions. From time to time it is found that a wave propagated from the point of stimulation can pass in one direction only. It starts well enough, perhaps, and reaches two points of the ring *A* and *B* (Fig. III); but at *A* it finds the muscle still insufficiently responsive, while at *B* recovery is more advanced. At *A* progress comes to an end, while at *B* the crest continues to move. Suppose that at this instant stimuli are withdrawn; the conditions are peculiar. Instead of two crests, advancing to meet and interfere,

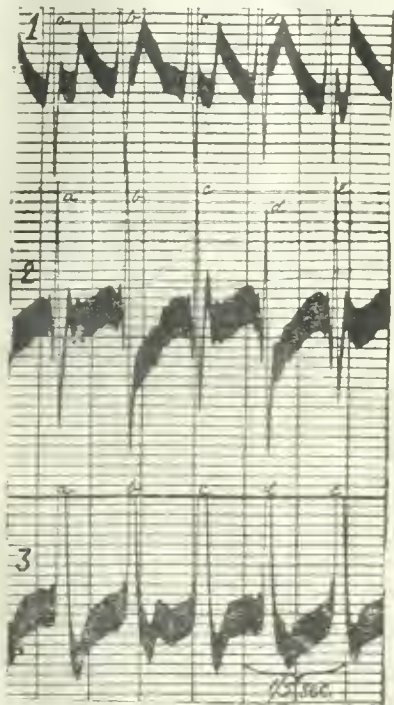

FIG. VI.—Three electrograms recorded simultaneously from the taenia terminalis of a dog while the auricle was fluttering. The top curve (1) was taken from the inferior caval, the bottom curve (3) from the superior caval, and the centre curve (2) from the mid region of the taenia. The record corresponds to five cycles of flutter (a-e). As each excitation wave passes, it signals itself by means of a sharp upward movement of the three recorders. Recorder 1 moves first, recorder 2 a fraction of a second later, and recorder 3 a fraction of a second later still. The order of excitation is 1, 2, and 3; the wave is passing up the taenia.

there is now but one, and it is free to circulate, for as it comes to each new segment (*C, D, E*) of the ring it finds this segment excitable (Fig. III, 2 to 4). The single excited wave consequently progresses around the whole ring, and, coming back to its starting point, finds that this muscle also has recovered (Fig. III, 5); it proceeds so long as the conditions remain unaltered; it continues its course as a circulating wave which has no ending (Fig. III, 6 to 10). Thus it has been shown that, the conditions being nicely controlled, the last stimulus of a series may originate, not a single response of the ring, but an unlimited series of responses. Mines saw the wave continue to circulate for minutes, Mayer saw it continue for very many hours; this is what is meant by circus movement; it is constituted by a wave of response which travels continuously along a re-entrant path of muscle.

AURICULAR FLUTTER.

We may now examine a condition of the mammalian auricle, to-day called auricular flutter. Flutter as we now understand it was first clearly described in a patient by Hertz and Goodhart in 1909; they studied their case by means of venous curves, showing the auricle to be beating continuously and regularly at a rate of 234 per minute.

Their description was quickly followed by the more ample records of Jolly and Ritchie, and of other writers. The rate of the auricular beating in flutter is from 230 to 350 per minute; the action of this chamber is remarkable, not only for its high rate, but for its regularity. It is to be recognized with the greatest certainty in electrocardiograms, of which examples are shown in Figs. IV and V. The condition is also remarkable because it continues uninterrupted for long periods of time. Sometimes it may occur in short paroxysms, more usually it comes to stay for months or years. Its nature until quite recently has remained altogether mysterious, though very numerous observations have indicated its close affinity to the condition called fibrillation. Thus flutter is often converted into fibrillation by the administration of digitalis. There have been few satisfactory records of a similar experimental condition. The term "flutter" was used by McWilliam as early as 1887; that was in the days when the two conditions flutter and fibrillation were not definitely

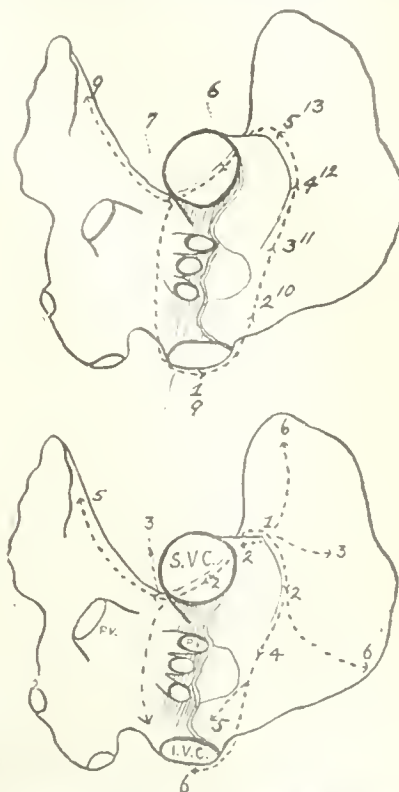

FIG. VII.—A natural outline of a dog's auricle, showing the paths of the excitation wave (broken lines) with the heart beat naturally (lower diagram) and during flutter (upper diagram). The numbers indicate the approximate area or point in which various parts of the musculature received the excitation wave.

distinguished. The first electrocardiograms of experimental flutter—and these curves are alone really distinctive—have been obtained during the past few years. We are now certain that a condition identical with that found clinically may be produced experimentally in the dog's auricle; this we have been taught by clinical and experimental electrocardiography.

In investigating disease there is one well known and most fruitful method of approach: it is to produce in animals a condition identical with that seen in the patient. When this has been accomplished it becomes possible to inquire into the precise nature of the disturbance. If and when that knowledge is obtained, we are in a position to consider rational plans of treatment. As I have related, in the case of flutter of the auricle, the first step has been taken. A continuous and rapid action of the dog's auricle can be produced in several ways, notably by rhythmically stimulating the organ with induction shocks at a rate of 300 to 600 per minute. The auricle is driven rhythmically and rapidly for a few seconds, and the stimuli are then abruptly withdrawn. In a certain proportion of such experiments a rapid action of the auricle continues after stimulation has ceased. The rate of action is not usually that of the rhythmic shocks which provoked

it; it is usually less. For the moment our chief concern is not the method of producing this rapid and continuous action, but its nature. Its nature is variable, but amongst the after-effects of stimulation a condition identical with clinical flutter is seen from time to time. It is not every auricle which is predisposed to flutter; it is not every stimulation which will invoke flutter in the predisposed organ. That, however, is immaterial, providing that we can produce it, and can be certain when it is produced that it is identical with the clinical condition. The electrical curves, clinical and experimental (Figs. IV and V) leave us with no doubt on this subject; these curves, so delicately analytical, place the conclusion beyond question.

Having produced experimental flutter, we proceed to investigate its nature. The method of investigation consists of mapping out the path taken by the excitation wave while flutter is in progress. A single illustration of method will perhaps suffice. The auricle of a dog has been forced into a state of flutter, as ascertained by electrocardiograms taken by methods comparable to those used clinically. The flutter continues uninterruptedly. Three points are now chosen in the line of the taenia terminalis, and to each of these a sensitive galvanometric recorder is connected. The curves of these recorders write simultaneously (Fig. VI). As the excitation waves flow through the muscle they pass beneath the several contact points, and at each the passage is signalled. The curves, considered together, show that each wave is passing regularly up the taenia from the region of the inferior to the region of the superior cava, and we are able to measure the rate at which it is travelling. This record is published to illustrate the orderly character of the events as the cycles are repeated, and to indicate with what certainty the direction taken by the excitation may be ascertained. Actually a slightly different plan of campaign to that described is usually adopted. It consists of maintaining one lead as a standard and moving a second to various points of the auricle, timing the arrival of the excitation wave at its several parts relative to the standard lead, and finally of its arrival at the several parts relative to each other. To exemplify in a simplified fashion a complete experiment I may use Fig. VII. This figure shows the natural outline of the auricle as it is seen from above. The two appendices project upwards in the diagram; the superior and inferior venae cavae are represented as transected. The figures 1, 2 and 4 in the lower diagram lie on the taenia terminalis. The order of excitation displayed by this animal while the heart beats normally is indicated in the lower diagram by the figures 1, 2, 3, 4, etc. The excitation wave, as is usual when the heart beats normally, starts in the region of 1, the point at which the sino-auricular node or "pacemaker" lies. A little later it is to be found simultaneously at the points marked 2. Follow the numerals and you perceive the course which it takes. It flows simultaneously along the muscular paths which radiate from the region of the node. Thus, it flows down the taenia to the inferior cava; it flows from the base to the tip of the right appendix; it flows through the intra-auricular band to the left auricle, and, still flying from its point of origin, traverses the left appendix from its base to its tip. The wave is not visible as a wave; it travels too fast for that; the whole process of spread occupies the twentieth part of a second.

In the top diagram of the figure is the essential part of the map for the same auricle in a state of rapid flutter. The order of excitation is quite different. The wave is first traced at the inferior vena cava (1) and it passes up the whole length of the taenia (2, 3, 4, and 5). Reaching the top of the taenia it moves around the superior cava and flows through the intra-auricular band (6 and 7) to reach the left auricle. It reaches the left appendix (9), and at the same instant a wave is timed to emerge from the inferior vena cava (9). The question which at once arises is whether this second wave, emerging from the inferior cava and repeating the course (10, 11, 12, 13, etc.) of the first wave, is a new wave or whether it is the continuation of the old one. Is there a succession of regular waves, each arising *de novo* in the inferior cava, or is there a single circulating wave? This question is answered by two considerations. If we propagate a wave artificially from the inferior cava, this spreads equal distances in equal times; it arrives at the two points 4 and 7 simultaneously. That is not the case in flutter; here it passes through

point 4 to reach point 7. But the decisive argument is found in the time relation of the wave; knowing the rate at which it travels along its path (1, 2, 3, 4, 5, 6, and 7) we can calculate how long it should take to move from 7 to 9, and can compare this calculated time interval with the actual interval observed; these are found to be the same within an inconspicuous margin of error. There can be no doubt, then, that we are dealing with a wave which circulates. It circulates in this experiment around a natural ring of muscle formed by the orifices of the two venae cavae. Looked at from above, the movement is in the opposite direction to the hands of a clock. In this instance it completed one circuit in 0.16 of a second; it completed therefore 380 circuits in one minute, and that was the rate at which the auricle beat.

The experiment which I have described is one of several, but it will suffice to illustrate the kind of evidence we possess of circus movement in the auricle. Flutter consists essentially of a continuously circulating wave. The path which this central or re-entrant wave usually takes is the one I have described, but that is not invariable. Sometimes in flutter the course is different; thus, the flow may be clockwise over the same route. In other cases only one cava is encircled; the path is shorter, and the circuits are more quickly completed consequently. In other cases, though these are not so clearly evidenced, the circus movement is around other natural orifices, such as the mitral orifice. These variations are chiefly of consequence because they render the experimental work more difficult; the important conclusion is that the wave can be shown to circulate when the auricle flutters. The proof of circus movement in the auricle is not confined to the class of experiment which I have cited; there is much more evidence that I can now give you; taken as a whole I believe it to be quite conclusive.

Now the wave as a whole is not, of course, confined to the central or re-entrant path; as it passes along this path offshoots are sent through the appendices to their tips, and into all other regions of the auricular muscle. Thus the movements of the whole auricular tissue is controlled by the circulating wave. There is the central or mother-wave, and there are its centrifugal offshoots into the remaining tissue.

Such is flutter as it occurs in the dog; such, therefore, is flutter as it occurs in man. In the dog we may see flutter last for hours; in man it may last, not for hours, but for years. I have known it to continue unceasingly for as long a period as seven years; for all we know it may continue even longer. A single wave continuously circulating for seven years; that, perhaps, may seem to be a remarkable conclusion; nevertheless, it is one we are now bound to accept.

THE FACTORS CONTROLLING FLUTTER.

We have seen that a condition comparable to clinical flutter may be produced in experiment; we have seen that when this experimental flutter is investigated it proves to consist essentially of a circulating wave. We may next consider the precise factors which maintain this circus movement. Refer back to the diagrams of the ring experiment and it will be clear that three factors are involved. They are:

1. The length of the central path.
2. The rate at which the wave travels.
3. The duration of the effective refractory period.

It must be evident that if the wave is to continue circulating a gap must exist between the crest of its advance and the wake of its retreat. As the crest travels it must always find the muscle which it enters in the responsive state. If for any reason the gap becomes closed, the wave will proceed no longer and the rapid action of the auricle will cease. The three factors named, and these alone, control the length of the gap. The duration of the refractory period at any given point must always be less than the time spent by the travelling wave in completing its circuit; this circulation time depends on the length of the path and the rate of travel. Now the rate of travel from point to point in the dog's auricle beating normally is approximately 1,000 mm. per second and the length of the refractory period at normal heart rates is approximately 0.15 to 0.2 of a second. In 0.15 to 0.2 of a second the wave will travel through 150 to 200 millimetres of muscle. On the basis of

these values a circus movement could not establish itself in a ring of muscle of less than 150 to 200 millimetres circumference. But it is known that much smaller circuits than these become established. What is the reason? The reason is that when the auricle flutters, the refractory period is reduced; also the rate of travel is usually reduced. These reductions both occur in response to an increased rate of beating such as prevails in flutter. Both changes facilitate the establishment of relatively short circus movements. The precise relations of the three controlling factors have now received close investigation. They are variable in different circumstances, but may be illustrated by a type experiment. A dog's auricle is fluttering at a rate of 500 per minute. Each circuit is completed in 0.12 of a second. The circuit has a length of 60 millimetres. The rate of travel is not 1,000 millimetres per second, but 500 millimetres per second. The rate of travel is but one-half the natural rate; that is so because the rate of beating is so high that the muscle is hard put to it to conduct the impulses. The length of the effective refractory period is not 0.20 but 0.10 of a second; it has become reduced with the rise of heart rate. The cycle is divided into two parts, a refractory phase of a tenth of a second, a responsive phase of a fiftieth of a second. The crest of the wave is constantly but a fiftieth of a second behind its own wake; it travels behind it at a distance of only 10 millimetres. We have direct and conclusive evidence that these figures may be taken as usually representative of the gap which exists; it is a minute gap, yet upon its existence the continued progress of the wave absolutely depends. To the question of this all-important gap I shall return at a later stage; it is a gap which will command the attention of many workers in the near future, for upon our power to influence its length, our success in treating flutter and, as we shall see, the closely allied condition fibrillation, will very largely depend. If by any means we could close that gap we could bring flutter to an abrupt termination.

CARCINOMA OF THE LARGE INTESTINE.

BY

J. LIONEL STRETTON, M.R.C.S.,

SENIOR SURGEON, KIDDERMINSTER INFIRMARY AND CHILDREN'S HOSPITAL.

THE treatment of cases of carcinoma of the large intestine is difficult. Most patients are fond of procrastination, especially in conditions where an operation enters into consideration. Time is lost with all sorts of examinations and investigations. X-ray photographs after bismuth meals, examinations and analyses of faeces, of vomit and of urine, and inspection with sigmoidoscopes often fail to reveal the early stages of carcinoma of the large intestine, which could be found if an exploratory examination were performed. I do not deprecate these examinations. They are all links in the chain, but they should neither be spread over too long a period nor have too much weight attached to them. Multitudinous drugs are swallowed; some of them give relief by their soporific action, thereby masking symptoms and assisting the disease to progress unrecognized. Strange diets are tried, and a varied assortment of patent foods is consumed. Spas are visited, baths, massage, and electrical treatment are indulged in; the abdomen is sometimes rubbed with bags of shot; enemata are resorted to; sometimes a course at Plombières. All is of no avail. The progress of the disease continues until the chances of cure by a radical operation are gone.

If abdominal pain with irregularity of the bowels, which is persistent for more than twelve months, were looked upon as sufficient to justify an exploratory operation many of these conditions would be disclosed before it is too late to eradicate them. It is very important to bear in mind that these carcinomata of the large intestine are not so likely to recur after operation as is carcinoma in other situations of the body. Provided that you can remove them during the first year or two the outlook is hopeful. I know a man working in this town now whose caecum I removed for carcinoma on February 7th, 1911, nearly ten years ago. He is well and strong and informs me that he

can carry 2 cwt. At the time of his operation he was only 28 years of age. Professor Leith, who examined a section of the growth, reported it to be "a cubical-celled carcinoma with a few columnar cells." I hope particular notice will be taken of this man's age, because I know that cases are overlooked because they are "too young to have carcinoma."

Then there is the question of haemorrhage. Many of these malignant cases do not show this symptom, yet it is present in many innocent conditions. There may be occult blood in the faeces, and so there may be in innocent conditions. Ballooning of the rectum is another condition which may be present in either malignant or innocent affections. These are links in the chain of evidence, but they are not strong enough to carry conviction.

The treatment I advocate for these cases is to operate early and freely. If there is a chance to perform a radical operation for the complete removal of the growth, by all means do so. It may not be wise to do it all at one sitting. This must depend upon the case. Take, for instance, Case IV, noted below. He was sodden with toxins, and would not have stood any lengthy operation. The obvious need was to relieve his obstruction, to free him of the poisonous matter he was absorbing. The next day I was able to perform a short-circuiting operation. Had the patient been in a good condition I should have excised the growth in the first instance.

The excision should be a free one. At least 4 in. of healthy bowel on each side of the growth, together with the mesentery and lymphatic glands, should be removed. There is some difference of opinion as to the best method to be adopted after excising the growth. Some surgeons close the ends and then perform a lateral anastomosis. I prefer an end-to-end junction. It is true that the calibres of the cut portions of bowel may be different, but that difficulty can easily be surmounted by careful suturing. The end-to-end junction is the nearest approach to Nature's arrangement, and this, I consider, should always be our aim. I prefer simple suture to any mechanical appliances, and I use linen thread, which is always reliable in my hands.

Between September 28th and October 16th last I operated upon five cases of carcinoma of the large intestine, two of them on one afternoon. When I say the large intestine I do not include the rectum. The disease is not common, and it is therefore remarkable that these five cases should have presented themselves to me within eighteen days. The following are brief histories of each of these patients:

CASE I.

W. O., a male, aged 54, had suffered from pain in the right side of his abdomen for twelve months. The pain was more acute at times, but the patient could not associate this with anything which might account for it. He had lost flesh, and was anaemic. An examination of the abdomen revealed a tense globular swelling, about three inches in diameter, in the right hypochondriac region. It was dull on percussion, and appeared to be attached to the liver. I could not separate it from the liver. There was a right inguinal hernia, which was easily reducible. It was thought that the swelling might be a distended gall bladder, and an exploratory operation was advised. On September 28th, 1920, under chloroform and ether, a vertical incision was made through the right rectus. The appendix was found to be thickened and inflamed, and was removed. A mass of hard carcinomatous growth was found in the hepatic flexure of the colon. It was delivered with difficulty and excised, with about four inches of the ascending colon and four of the transverse colon on either side. An end-to-end junction was made by simple suture with linen thread. Enlarged glands were removed with the mesentery of the colon. The patient made an uninterrupted recovery, and was discharged on October 23rd. His bowels act regularly, and he has no pain.

CASE II.

E. T., a female, aged 45, had suffered from pain in the right hypochondriac region for more than a year. The pain was worse at times, and went through to her back. She thought she had gall stones. On examination of the abdomen there was tenderness and rigidity in the right iliac region. The patient would not allow a full examination. It was thought she might have chronic appendicitis. On September 28th, 1920, under chloroform and ether, I could feel a hard, irregular mass in the right iliac region, which I thought was a carcinoma of the caecum. A vertical incision was made through the right rectus. The carcinoma of the caecum was delivered and excised, together with the enlarged glands in the mesentery, 4 in. of ileum, and 4 in. of ascending colon. End-to-end junction was made with linen thread. I show you the specimen removed. You will notice that the growth is confined to the caecum; the appendix was not affected. The patient made an uninterrupted recovery, and was discharged on November 1st. Her bowels act regularly, and she has no pain.

* Read before the Kidderminster Medical Society on December 3rd, 1920.

CASE III.

G. B., a male, aged 55, had suffered from pain in his right iliac region for several months, probably more than a year. He had had difficulty in getting his bowels moved, and had lost weight. On examination of his abdomen a hard, irregular mass could be felt in the right iliac region. It was freely movable and was not tender. It was thought to be a carcinoma of the caecum. On October 5th, 1920, under chloroform and ether, the abdomen was opened by a vertical incision through the right rectus. The caecum, which was invaded by a carcinomatous growth, was removed with its mesentery, containing enlarged lymphatic glands. About 4 in. of the ileum and 4 in. of the ascending colon were removed. An end-to-end junction was made by simple suture with linen thread. I show the specimen removed, and you will notice that in this case also the growth was confined to the caecum, the appendix not being involved. The patient's after-progress was at first satisfactory. The sutures were removed from the abdomen on October 14th, when the wound was healed, with the exception of a sinus where the tube had been inserted. Three days later he began to fail, and he died of exhaustion on October 20th.

CASE IV.

R. P., a male, aged 68, had suffered from partial obstruction of the bowels for six weeks. The obstruction had been complete for a week. He had been vomiting for two days. The abdomen was tense and distended. Nothing could be felt. On October 11th, 1920, under chloroform and ether, a vertical incision was made through the left rectus muscle. On introducing the hand, a mass of new growth (carcinoma) was felt in the caecum. A Paul's tube was tied into the lower end of the ileum and about 50 oz. of foul-smelling intestinal contents drained off. The loop of intestine was fixed on the abdominal surface. The following day the patient was much improved, another 50 oz. of intestinal contents having drained away during the night. Chloroform and ether was again administered. About 12 in. of the small intestine was resected (including the aperture of the Paul's tube). The distal end was closed and returned to the abdomen; the proximal end was sewn into the transverse colon by simple suture with linen thread. I was unable to bring out the descending colon easily. The patient progressed satisfactorily for three days and then became weaker. His breathing was laboured, and he died on October 16th, at 11.45 p.m. There was no peritonitis and his abdomen was flaccid.

CASE V.

K. P., a female, aged 62, had had complete obstruction of the bowel for three days. The abdomen was distended. She had not vomited. On October 16th, 1920, under chloroform and ether, a vertical incision was made through the left rectus. On introducing the hand, a hard, annular stricture was found in the pelvic colon. It could not be brought outside the abdomen. A preliminary colotomy was performed on the descending colon and the bowel was opened immediately to give relief. On the 19th the patient was again placed under an anaesthetic and the colostomy was completed by division of the bowel. The result is satisfactory.

You will notice that four of these cases were of the columnar type and only one of the sclerosing form. In my experience the latter is more common. Three of the cases occurred in the caecum, one in the hepatic flexure, and one in the pelvic colon. In my experience the last named is more common, and it is usually of the sclerosing type. In some cases symptoms of sufficient importance are not noticed until obstruction occurs; even then the discomfort may not be great and it is often difficult to make the patient realize the danger he is in.

I have had the opportunity of observing several cases of this condition where operation had been refused or decided against. In each instance there was a perforation in about six weeks' time, accompanied by agonizing pain. One of the patients then begged me to perform an operation, which she had often refused previously. I washed out her peritoneum, stayed her agony, and enabled her to die in comfort. Another case I immediately relieved with an anaesthetic until the morphine had taken effect. All of these cases ruptured in the caecum.

In Case I there was a mass to be felt which appeared to be attached to his liver. His attendant, Dr. H. Miles, informed me after I had examined the case that he massaged this mass and it entirely disappeared. Perhaps if I had paid more attention to this information I might have suspected a collection in the bowel, which had been forced onwards. In Case II it was the tenderness and rigidity in her right iliac region which caused the patient to seek advice. It was a question between appendix trouble and gall stones. She was too rigid to allow of a proper examination, but when she was under the anaesthetic I had no difficulty in feeling a hard mass, which I diagnosed as a carcinoma of the caecum. In Case III there was a definite hard tumour to be felt in the iliac region. It was sufficiently well defined to allow of a

correct diagnosis, but the man was too far gone for cure to be possible. In Case IV a complete obstruction for a week, with its attendant toxæmia, suggested that the obstruction was in the proximal end of the large intestine, while in Case V the picture pointed to a stricture in the distal portion.

The operation is a serious one and its mortality rate is high, but the alternative is either death or an artificial anus. Every case must be decided according to circumstances. I can imagine that the continuation of life for a brief period may be so imperative that a colotomy should be chosen in preference to an enterectomy. Even then the major operation might be performed at a later date. Some people, I know, would prefer death to either a colotomy or a colostomy, and there is much to be said for their view. If the growth is too extensive for removal it may be possible to perform a short-circuiting operation. This will give immediate relief without the horrors connected with an artificial anus.

I think that if the facts are put fairly before patients they will, in the vast majority of instances, accept the operation which will remove their disease, no matter what the risk. Of course, a surgeon is often placed in the position of making the decision himself. In the first two cases noted above I did not suspect the real condition, and it was not until after the patients were under the influence of the anaesthetic that I was aware of it. In neither case had I any hesitation in resecting the bowel, and both of them have made satisfactory recoveries. Perhaps they may be as fortunate as the man upon whom I operated in 1911. It depends largely upon the duration of their disease. If we are to obtain good results, we must get the cases sufficiently early.

I have already said that the onset of the disease is insidious, and that the symptoms may be slight, but I have also said:

"If abdominal pain with irregularity of the bowels, which is persistent for more than twelve months, were looked upon as sufficient to justify an exploratory operation many of these conditions would be disclosed before it is too late to eradicate them."

This is a question which is in the hands of the general practitioner rather than of the surgeon. It is he who has to watch the onset, and if he can realize the truth of my assertion he will be in a position to put before his patients the advantage which may result from an exploratory operation performed before they have drifted into a condition which is beyond the stage of cure, if not of alleviation.

GUNSHOT INJURY TO THE BRAIN INVOLVING BOTH CORTICAL AND SUBCORTICAL TISSUE.

By JUDSON S. BURY, M.D., LOND., F.R.C.P.,

VISITING PHYSICIAN TO THE NEUROLOGICAL HOSPITAL FOR PENSIONERS AT BRINNINGTON; CONSULTING PHYSICIAN TO THE MANCHESTER ROYAL INFIRMARY.

THE medical profession is greatly indebted to Henry Head for his contributions to the symptomatology of disease. In his very able and philosophic writings on sensation, the outcome of many years' painstaking investigations, he has furnished us with criteria by means of which we can locate a lesion implicating any part of the afferent system, whether this be in the peripheral nerves, the spinal cord, the brain stem, the optic thalamus, the internal capsule, its afferent fibres, or the cortex. Obviously the practical value of such criteria is very great, for they enable us to determine the situation of a lesion which, from a consideration of the motor and other symptoms of a case, we may not be able to do with certainty.

In some cases, however, when more than one part of the sensory system is affected, it may be difficult to decide from an examination of sensation which part is mainly involved. Thus, in the following case I have found it difficult to determine the extent to which the sensory disturbance is due to cortical or to subcortical destruction:

Private N., aged 52, was admitted to Brinnington Hospital on June 12th, 1920. At 9 a.m. on March 10th, 1915, he was shot in the head by a rifle bullet; he felt as if his head had been hit with a stick. He fell down, fancying "he saw little devils and that bells were ringing." He does not think he completely lost

consciousness, because he heard someone shout "stretcher-bearers." He was not, however, removed from the trench where he was shot till 7 p.m.; then he was fully conscious. He says that his right leg was crossed over the left, that both legs were useless, though he could move them very slightly. He could move his right arm a little, but was unable to move his left. The same night he was trephined; he does not know whether the bullet was found. His speech was impaired for about two months, and he had special difficulties with the letter "l." His right arm remained weak for about a month; his legs gradually regained some power, and by Christmas, 1916, he could feebly hobble about with the help of sticks. From March to June, 1916, he was in King's College Hospital, and later in King George's Hospital, where his head was x-rayed, but "nothing was found." He has been subject to attacks occurring every few weeks, which begin with a "filling-up sensation on the left side of the windpipe," then the left side of the mouth is puckered up and firmly closed; there is also slight twitching of the left side of the face; the mouth waters and he cannot speak for a few seconds; he does not feel confused. He says an attack lasts less than a minute; no attack has been seen since he came into the hospital.

Present State.

His present condition, six years after the injury, is as follows: His mental state, his speech, special senses, pupils, and the movements of his eyes are normal. The wound is represented by a lanceolate depression, 5 cm. in length and from 2 to 3 cm.

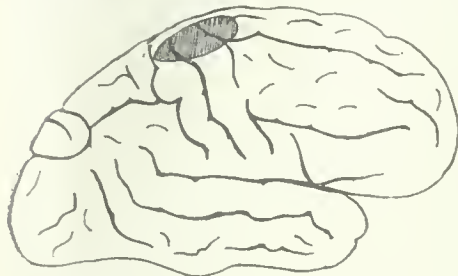

to the right of the middle line; its anterior end is 16 cm. from the nasion, its posterior 19 cm. from theinion. The deepest part of the depression, which is near the anterior end, admits the tip of a finger, and the pulsation

of the brain can be felt. In the accompanying diagram, kindly made for me by Professor Stopford, the probable position of the lesion is shown.

Motion.—The right arm and hand are normal. Some of the movements of the right foot are weak, and there is left hemiplegia. The weakness of the left side of the face is very slight. There is much rigidity of the left arm; the movements at the elbow and shoulder are strong, but weaker and stiffer than those of the right arm. The wrist is semiflexed, and his power to bend it more or to extend it is of the slightest. The hand is rigidly pronated, and he is unable to supinate it. The fingers, touching one another, are flexed at the two proximal joints and extended at the distal; the first joint of the thumb is slightly flexed, the second is extended, and the palmar surface of the end rests on the base of the terminal phalanx of the index finger. His attempts to move the digits are very feeble. The movements at the left hip and knee are good, but slightly weaker than those on the right side. Dorsiflexion of both feet is much impaired; that of the left foot is almost completely paralysed, that of the right foot is limited to a feeble inversion movement.

Reflexes.—Both knee-jerks are exaggerated, the left jerk more than the right. There is ankle clonus, most marked on the left side. Both plantar reflexes give an extensor response. The abdominal reflexes are feebler on the left than on the right side.

Sensation.—This is normal on the right side. On the left side gentle stroking with a wisp of cotton-wool is felt, but to a less degree than on the right side. The difference is scarcely appreciable on the face and trunk; sometimes he is uncertain, but his answers are usually in favour of the sensation being less plain on the left side. The difference, though still slight, is more distinct on the arms and legs, and is considerable when the fingers are tested. The ends of the fingers are most affected, and their palmar surface more than the dorsal, but his answers are inconstant; sometimes he feels gentle stroking, sometimes firmer stroking elicits no response. Tactile sensibility gradually improves in passing from the ends of the fingers to the wrist. Pressure touch over the fingers also seems to be diminished.

Localisation. tested with a screen and observer's hand, is probably impaired, but the patient's indications are uncertain; sometimes they are correct, sometimes not—thus he may point to the fourth finger when either the second or the third is touched.

The appreciation of roughness appears to be normal, different grades being promptly recognized.

The vibrations of a tuning-fork are felt, but to a less degree than on the right side; they are felt two seconds longer on the joints of the right fingers, seven seconds over the styloid processes, and four or five seconds longer over the olecranon than over these prominences on the left side.

Compasses.—The threshold for recognizing two simultaneous contacts is probably raised on the left side: thus over the tips of the fingers it is 4 mm. on the right side and 5 mm. on the left; over the back of the forearm and the dorsum of the foot it is

2 to 3 cm. higher on the left side than the right. But the answers to this test are also uncertain; occasionally, indeed, a higher threshold is obtained on the right side.

Pain.—The prick of a pin is felt on the left side, but is less sharp than on the right side.

Pressure Pain.—The threshold, as measured with the algometer, is higher on the left side, the amount of pressure to evoke pain being ten on the left palm and seven on the right.

Thermal sensibility is not affected; he can distinguish cold from hot and also intermediate temperatures.

Position.—With eyes closed he cannot tell the position into which his arm is placed. In trying to touch the tip of one of his left fingers the normal finger goes usually to the ulnar side of the hand and sometimes to the base of the fingers and then gropes its way to the tip; occasionally it gets nearly to the tip at the first trial. The position of the fingers is often correctly imitated by the right fingers, but sometimes when the fingers, especially the second and third, are flexed, he thinks they are extended. He is apt to make mistakes as to the fingers moved; thus he may say it is the second finger when the third or the fourth has been moved. Slight passive movements of the fingers are not recognized, and large ranges of movement often elicit incorrect or uncertain answers.

The appreciation of weight is much impaired; with the right hand he recognizes that one ounce is heavier than half an ounce, with the left hand he does not appreciate any difference between one ounce and four ounces. The impairment is perhaps greater when the hand is supported than when unsupported. Curiously enough, he sometimes thinks the heavier weight is the lighter of two successive applications.

The appreciation of size, shape, and form is lost, and he is unable to name any common object, such as a knife, key, or coin, placed in the affected hand. He knows that something is in his hand, but cannot tell what it is. He does not feel any difference between a large watch and a florin, or between half a crown and a sixpence.

Texture is not appreciated; he does not feel any difference between silk, velvet and flannel.

The main features of this case—namely, the hemiplegia and the hemianesthesia—indicate a subcortical rather than a cortical lesion, whilst the paralysis of certain movements of the right foot shows that the lesion is not limited to the right cerebral hemisphere, but crosses the middle line to implicate the top of the left precontrol convolution or more probably the fibres proceeding from it.

The changes in sensation on the left side cannot, however, be wholly explained by a subcortical lesion. The uncertainty in the patient's responses to tactile impressions, to localization, and sometimes to the compass test suggests interference with the sensory activity of the cortex, which is still further indicated by the inability to recognize objects placed in his hand, combined with a loss of appreciation of weight. The loss of recognition of the posture of the affected arm—a striking feature of the case—may occur in subcortical as well as in cortical lesions, but in the former condition, Henry Head says, "the patient remains conscious of the existence of his limbs, though he does not know where they lie, whilst with lesions of the cortex he may lose all consciousness of the existence of the affected parts." I have found it difficult to make my patient appreciate the distinction. He says that on waking from sleep he does not know where his left arm is, but cannot say whether or not he is conscious of the existence of the limb.

THE SURGICAL TREATMENT OF CHRONIC SCIATICA.

17

J. MILL RENTON, M.B., Ch.B., F.R.C.S. EDIN.,

ASSISTANT SURGEON, WESTERN INFIRMARY, SURGEON, OUT-PATIENTS, ROYAL HOSPITAL FOR SICK CHILDREN, GLASGOW.

WHILE the majority of cases of sciatica can be cured by medical means there are still a certain number in which medical treatment fails. In these cases the patients are usually almost completely incapacitated by their pain and, if it is not relieved, they tend to drift into a condition of chronic invalidism. I am satisfied that, in a considerable proportion of these cases, a rapid and complete recovery can be obtained by operation. The benefits of surgical treatment have not been as widely recognized as they might, on account, I think, of two reasons: (1) a lack of appreciation of the type of case suitable for operation, and (2) the performance of an unsatisfactory operation—namely, nerve stretching. If the correct type of case is

Read at a meeting of the Royal Medico-Chirurgical Society of Glasgow, March 18th, 1921.

selected and the operation of nerve-freeing performed, a cure can be obtained in practically every instance.

The term "sciatica" is often used to cover pain in the sciatic nerve arising from very different causes, so that, in the first instance, it is necessary to be particular regarding the diagnosis. A considerable number of diseases may cause referred pain in the sciatic nerve, such as hip-joint affections, tumours or inflammatory conditions in the pelvis, exostosis, and nervous conditions both organic and functional. It is therefore essential to exclude all such causes of sciatic pain by a careful examination before one assumes one is dealing with a lesion of the nerve itself. The term "sciatica" should be confined to pain arising from inflammation or the effects of inflammation of the sciatic nerve.

It is only in chronic cases that have failed to recover under medical treatment that there is any question of surgical interference. Further, not all of those chronic cases are suitable for operation, so that it is necessary to differentiate them carefully by the symptoms to which they give rise. I have roughly classified them into three groups:

1. Cases in which the patient is quite free from pain while at rest but begins to have pain on exercise or on assuming some special position.
2. Cases in which there is a certain amount of pain while at rest, but where it becomes really intense on exercise or on the assumption of a particular position.
3. Cases in which the pain is of an indefinite character, present at rest off and on, and sometimes improving to a certain extent on exercise.

In the first type the pathology of the condition seems quite clear. The inflammation of the nerve has subsided, but adhesions have been left round the nerve as a result of the inflammation. These vary from fine adhesions to definite bands of fibrous tissue. Their mode of action seems clear, as it is only on movement that they drag on the nerve and set up pain. This type is pre-eminently the one suited for surgical treatment, and in cases of this nature one can be certain of a rapid and perfect recovery by operation.

In the second type one has the same condition of adhesions round the nerve, but, in addition, one presumes there is a varying amount of inflammation of the nerve itself still present. In some instances it is possible this may be kept up by the pull of the adhesions, especially where the patient has been making great efforts to go about. The majority of cases of this nature can also be cured by operation. In this class of case the pain sometimes takes longer to disappear completely.

In the third type the pathology is not so clear, but it would seem likely that here one has a neuritis without the presence of adhesions round the nerve. In the only case of this kind where I have operated no adhesions were found. This type appears to be unsuitable for surgical treatment.

Treatment.

The surgical treatment of sciatica was first placed on a satisfactory basis by Crawford Renton,¹ who in 1897 published an account of his operation and of the cases where it was indicated. The operation is extremely simple, and consists essentially in the freeing of the sciatic nerve from adhesions. This is done by exposing the nerve below the gluteus maximus by a four to five inch longitudinal incision, hooking it up, and then carefully removing all adhesions from the sacro-sciatic notch to about the middle of the thigh. The adhesions may be fine and readily separated by the finger, or they may consist of strong bands that have to be divided. All tags and loose ends of adhesions should be dissected away. The branches to the hamstrings which come off just below the lower border of the gluteus maximus should be preserved. The nerve is then dropped back into the wound and the skin sutured. No splint is applied, but the patient is kept in bed for ten days and then allowed up.

In performing this operation one does to a certain extent pull on the nerve, but the essential feature is the removal of the adhesions. It is quite easy to demonstrate that no reasonable amount of nerve stretching will separate all the adhesions. Further, cases have been cured by this operation which had previously had nerve stretching performed without benefit. As a general rule patients are free from pain as soon as they get up, but sometimes a few weeks elapse before the pain completely disappears. The

results of this simple operation have been most satisfactory, and patients who had been more or less confined to bed for periods of six months to two years have been able to take up active occupations in a short time.

It is not possible to give records of a very large series of cases, as the operation is only indicated in a limited number of patients. Crawford Renton² has recorded thirty-two cases of operation extending over a period of thirteen years, and all of these were cured or rendered well enough to return to active life. I personally have operated on ten cases; six of these were of Type I, and all of them recovered completely; three were of Type II, and of these two made a complete recovery, but the third, although greatly improved and able to return to active work, still complained of some pain and numbness of his foot a year later. One case was of Type III; no adhesions were found, and no benefit followed the operation.

Illustrative Cases.

Type I.—I. R., a woman aged 33, a patient of Dr. MacLennan, Govan. She had been almost entirely confined to bed for nine months with a left-sided sciatica. Under medical treatment the acute pain had passed off and she was now quite comfortable when lying in bed. On attempting to walk the pain came on severely, and she particularly complained of being unable to sit for more than a few minutes without the pain becoming so severe that she had to lie down. There was practically no tenderness on pressure over the nerve, but stretching it was painful. There was some atrophy of the thigh and the Achilles reflex was diminished. At operation definite adhesions were found round the sciatic nerve, and these were freed. A fortnight afterwards she could walk and sit without pain, and five months later she remained perfectly well.

Type II.—W. M., a sailor aged 29. He had been completely incapacitated with pain in his right sciatic nerve for six months. He complained of a certain amount of pain even when resting, but especially of inability to walk any distance without the pain becoming so severe that he had to stop. There was some tenderness over the nerve, and it was painful on stretching. There was some atrophy of the thigh and the Achilles jerk could not be elicited. His sciatic nerve was freed from adhesions and a few weeks later he was quite comfortable and able to walk without pain. When seen nine months later he was still perfectly well.

R. D., a man aged 53, a patient of Dr. Gibson Graham, had had pain in his left sciatic nerve for eighteen months. In spite of medical and electrical treatment it did not improve. He complained of pain and numbness in his leg and foot even when at rest. Exercise greatly increased the pain, and he could only walk a short distance. There was tenderness over the nerve and pain on stretching it. There was atrophy of his thigh and leg muscles, and the Achilles reflex was gone. The sciatic nerve was exposed, and a considerable number of adhesions separated. A month after operation he could walk much better, although he still complained of some pain. He improved steadily, and was able to return to active work three months later. At the present time—a year after operation—he is doing active work, but states that he still has some pain and numbness of his foot at times. His Achilles jerk is still absent.

Type III.—J. S., a man aged 50. He gave a history of sciatic pain on the left side of two years' duration, which had persisted in spite of medical treatment. He complained of irregular attacks of pain often coming on while at rest. The pain was sometimes severe in the morning, and improved when he had been going about for a little. There was tenderness over the nerve and pain on stretching it, as well as considerable atrophy of the thigh and gluteal muscles. The Achilles reflex was absent. At operation practically no adhesions were found, and no improvement followed.

Conclusions.

1. Cases of sciatica which are free from pain while at rest but in which the pain commences on exercise can be cured by operation.
2. Cases in which there is a certain amount of pain while at rest but where it becomes much more severe on exercise can usually be cured, or at any rate greatly improved, by operation.
3. The operation consists in the freeing of the sciatic nerve from adhesions and not merely in nerve stretching.

REFERENCES.

- ¹ Crawford Renton: The Surgical Treatment of Sciatica. *Scottish Med. and Surg. Journ.*, 1897. ² Crawford Renton: Sciatica and its Surgical Treatment, *Proceedings of the Royal Society of Medicine*, Surg. Section, May, 1908.

IN A paper read at a meeting of the Society of Public Analysts, on April 6th, Dr. J. C. Thresh stated that the conflicting views held with reference to the action of water on lead had induced him to reinvestigate the matter. He found that if water were free from dissolved oxygen it had no action on lead, but that if free oxygen were present action began instantly and continued until all the oxygen was used up.

SURVIVAL AFTER OPERATION FOR ANNULAR MALIGNANT DISEASE OF THE LARGE BOWEL.

BY

JOHN D. MALCOLM, F.R.C.S. EDIN.,

CONSULTING SURGEON, SAMARITAN FREE HOSPITAL, LONDON.

THE CASES here recorded encourage a resort to surgical treatment:

CASE I.—Lived Seven and a Half Years with a Fistula.

A man, aged 78, of powerful physique, seen with Dr. Andrew Elliot and Dr. R. P. Cockburn, had suffered for many months from an increasing intestinal obstruction located in the transverse colon. Operative treatment was recommended, but no guarantee could be given that the formation of a fistula would be avoidable, and nothing was done until a bout of vomiting with increasing abdominal distension seemed likely to terminate in death. During this attack, on June 15th, 1913, I opened the abdomen in the middle line above the umbilicus, and felt an annular constriction of the transverse colon near the splenic flexure. A lateral fistula was made in the presenting portion of the enormously dilated large bowel, which was afterwards identified as ascending colon. Further treatment was considered unwise at that time.

The patient bore the operation well, and recovered satisfactorily with hardly any vascular or other disturbance. From the first he was subject to attacks due to accumulations in the transverse colon which were accompanied by pain, discomfort and high temperature, until an offensive discharge took place through the fistula. Dr. Cockburn kindly informs me that after about four years these attacks began to be associated with escapes of irritating matter, mainly mucus, through the anus, by which small quantities of faeces were passed at intervals to the last. Between the attacks the patient was wonderfully well and able to go out until the end of October, 1920, about which time secondary nodules were discovered, first in the hepatic flexure, and later throughout the abdomen. The patient died on January 6th, 1921, more than seven and a half years after the operation.

It was proposed to short-circuit this patient's ileum into his sigmoid flexure and, if possible, to remove the strictured bowel when he recovered from the fistula formation. Elderly people of strong physique, especially those with powerful hearts, bear operations well, and this patient appeared to be capable of undergoing successfully the necessary interference, but he refused further surgical treatment. His record shows that an annular malignant stricture of the colon may long remain local, and clearly the full advantages which surgery may give were not obtained in this case. After a successful second operation the man might have been quite well now, but such results cannot be secured without risk.

CASE II.—Apparently well 23 Months after Hysterectomy and Proctectomy.

A woman, aged 44, married five years but never pregnant, was sent to the Samaritan Free Hospital under my care by Dr. Reginald Clark. An abdominal tumour apparently existed before her marriage and greatly increased in size in the last few months, during which the patient rapidly lost weight until emaciation, anaemia, and feebleness were extreme. There was no intra-abdominal pain or tenderness, but vaginismus prevented a satisfactory examination. On March 28th, 1919, under anaesthesia, an oval tumour was defined rising to the ribs from low in the pelvis, and so fixed by its size that its origin could not be ascertained. A uterine sound was not used. In the rectum, three inches from the anus, an ulcerating growth completely encircled the bowel, but caused no constriction and little discharge. A piece of this, removed for examination, showed the structure of a carcinoma. The rectum moved freely behind the large tumour, which was thought to be ovarian and probably malignant.

The proper treatment was to operate if the rectal condition had not existed, and the rectal growth, apart from the other, appeared to be removable. The propriety of interference with these doubtful conditions had to be the more seriously considered because of the feeble condition of the patient. She, however, expressed a very strong desire to take any risk on the chance of getting relief from her discomfort and sense of weakness. It was therefore decided to explore the abdomen, the patient being told that if the large tumour could be removed it would be wise to treat the rectum by a second operation later.

First Operation.—On April 1st, 1919, an incision exposed a large fibromyomatous uterus, with its base deeply buried in very oedematous broad ligaments. The oedema seemed to be due to pressure. The whole uterus and the left ovary and tube were removed. Before closing the abdomen the rectal growth was examined and no sign of its extension beyond the bowel was found. The liver also seemed normal. The patient, although somewhat collapsed for a few days, recovered well.

The highest temperature was 100.4 F., the highest pulse 110. The tumour contained many cysts full of degenerating fluid, but no malignant growth was found in it.

Second Operation. Five weeks later, on May 6th, 1919, the patient's condition being much improved, the abdomen was again opened. After freely separating the rectum from its connexions, an attempt was made to bring the upper end of the divided sigmoid flexure down to be joined to the bowel close to the anus. This was impossible without either undue tension or division of a large vessel which nourished the greater part of the sigmoid. The attempt to make an end-to-end anastomosis had therefore to be abandoned, and the divided upper end of the sigmoid flexure was brought out on the groin as a fistula. After removal of the rectum and the anal mucous membrane down to the external sphincter, the pelvic floor was closed with difficulty, because of the absence of the uterus. The right ovary and tube helped to fill the gap, but a very large cavity remained and was packed with gauze round a drainage tube introduced through the anal wound. The abdominal incision was then closed.

After-History. The patient was much more feeble after this operation than after the first, and a great deal of discharge escaped from the anal opening, but it gradually ceased. The temperature rose to 103 F. on the third day, the pulse to 120. Both then fell until the fourteenth day, after which they were normal and the patient went home, almost healed, fifty-one days after the second operation. A month later (July, 1919) she weighed 6 st. 7 lb. On December 21st, 1920, she weighed 11 st. 13 lb. and had every appearance of robust health. The pelvic parts were all soft and the fistula acted well.

Dr. W. H. Baker tells me that her condition is still quite satisfactory. Of course, within two years of an operation for cancer a patient's future must be considered uncertain, but the first of these histories shows that a bowel cancer may be localized for a long time. In the second it seemed certain that a wide removal of the disease had been effected, and in any case the result to the patient has already amply justified the operative interference.

THE HOSPITAL TREATMENT OF FRACTURES:

A SUGGESTION FOR CENTRALIZATION.

BY

ROBERT OLLERENSHAW, F.R.C.S. ENG.,

HONORARY SURGEON IN CHARGE OF ORTHOPAEDIC DEPARTMENT, SALFORD ROYAL HOSPITAL.

IN 1908, in an address before the Medical Society of London, on the "After-effects of injuries," the late Mr. Clinton Dent made some statements as to the results of fractures amongst members of the Metropolitan Police Force. These men, who, before their injuries, were physically almost perfect, were treated in various metropolitan hospitals, and Mr. Dent, as consulting surgeon to the police, had to pass judgement on the final result and estimate the functional recovery. He stated that the results were much less favourable than was generally imagined, and he made a strong plea for the better care of fractures. He particularly pleaded that early fixation in plaster-of-Paris for a period judged to be long enough to ensure sound union should not be adopted as a routine line of treatment. He found that, after fractures of the lower limb, 30 per cent. failed permanently to get full functional recovery, and very few had fully recovered in six months from the time of the injury. It is probable that this figure represents fairly accurately the state of affairs to-day.

In 1908, and since that time, the fractures admitted to most of our general hospitals went to the wards which happened to be receiving urgent cases, quite regardless of whether the surgeon in charge of those wards had any special interest in the treatment of fractures or not. In most busy general surgical units a serious fracture is not looked upon as a welcome visitor. It is a case which is certain to hold up a bed for a long period, and which will interfere with the admission of more interesting general surgical cases. In the present state of busy wards and long waiting lists, it becomes almost the first business, therefore, to get the fractures disposed of as quickly as possible. Two chief methods offer themselves: First, transfer to a Poor Law hospital with its multitudinous beds, or, secondly, discharge to the patient's home after fixation on some form of splint which cannot be interfered with, such as plaster-of-Paris.

When one remembers that an inferior result after a fracture of the lower extremity may permanently reduce

the capacity of a young and strong workman from full hard work to light work, or "no ladder work," or some seriously limited occupation, it is obvious that the very best effort should be put forward to procure the most perfect functional result which is possible. In order to ensure this result it is very desirable that the same surgeon should supervise the case from start to finish. He should be entirely responsible for the case whilst in the wards; he should supervise its manipulation and splinting, its early massage, and, on discharge, its progress through the out-patient department and physio-therapeutic department. He should control the entire physio-therapeutic treatment.

Many of our general hospitals now have orthopaedic departments. In these hospitals the fractures naturally go to the wards associated with this department. The work of an orthopaedic surgeon differs in one very important respect from that of the general surgeon in that the former frequently has to undertake much more prolonged after-treatment of his patients. The operative measures employed, though essential and highly important, may be a mere incident in the course of the whole treatment. Weeks or months of patient physio-therapeutic measures, accompanied by the constant supervision and adjustment of mechanical appliances, may be required in order that the value of the operation may not be lost.

Similarly in the case of fractures, supervision of the whole of the after-treatment is of the very highest importance. In hospitals which have no special department for orthopaedics, a member of the surgical staff should be selected to take charge of the fractures. He should naturally be one with some leaning towards orthopaedics, who would be able to devote the necessary time to the work, which would, in this case, be in addition to his general surgical duties. He should be allotted a sufficient number of additional beds for fractures. This number will be arrived at from a survey of the in-patient records. It will be found to work out, in the average general hospital, at 6 per cent. of the total surgical beds. In areas which are almost entirely industrial this figure may be a little higher.

Under a system of centralization such as this the surgeon in charge becomes more expert in his methods, the house-surgeon of the unit receives real thorough instruction and practice in his art, the nursing staff becomes extremely skilled in the handling and adjustment of splints and the nursing of patients in fracture apparatus, and the general wards are relieved of cases which are somewhat alien to them. At Salford Royal Hospital, where an orthopaedic department was opened in 1918, the system has worked extremely well and with the greatest advantage to all concerned.

NOTES ON A GIANT.

BY

WILLIAM ROBINSON, M.S., F.R.C.S.ENG.,
SENIOR SURGEON, ROYAL INFIRMARY, SUNDERLAND.

SINCE Ord described "the cretinoid state in adult women," and surgeons showed that complete removal of the thyroid gland brought about myxoedema, the functions of the ductless glands have been constantly investigated. Before that time we knew only that the complete removal of the sexual glands in man, sheep, cattle, horses, and other animals not only prevented reproduction, but made them docile and fat, thus affecting character as well as growth. Afterwards Marie, in 1885, showed that growths and hypertrophy of the pituitary gland caused acromegaly, and since then it has been slowly established by surgeons that the anterior lobe of the pituitary gland presides over the growth of the body. This discovery led Professor D. J. Cunningham to slip his finger through the foramen magnum of the skull of Hunter's costly giant, Byrne, in the Hunterian Museum, and to discover its expanded and shallow pituitary fossa; and Professor Arthur Keith later to cut a window in the cranial vault, and so render the enlarged fossa visible to the eye. (John Hunter is said to have paid the watchers of Byrne's corpse £500 to allow the body to be kidnapped.)

Recently E. Uhlenroth, of the Rockefeller Institute, has produced experimental giantism—that is, growth beyond the normal size of the species—in salamanders by feeding them on the anterior lobe of the pituitary gland. The function of the posterior lobe is unknown, and when given as food not only was growth not stimulated, but actually retarded. It is the intermediate part of the gland that supplies the extracts which excite unstriated muscle, raise blood pressure, and produce diuresis.

The effect produced depends on the developmental stage of the salamander; no effect is produced on the larvae. At the stage when growth ceases or is normally much lessened, cell proliferation can be enforced by the specific substance in the anterior lobe of the hypophysis.*

The giant "F." consulted me six or seven years ago. He was then 20 years of age, his height was 7 ft. 8 in., he

was still growing, and he weighed over 22 st. Although so tall he was fairly proportionate, except that his hands, feet, skull, and lower jaw were perhaps unduly large. His hands were long and shapely, and differed from the short, broad, spade-like hands and sausage-like fingers of the acromegalic, the age of onset accounting for the difference. When the disease is congenital or begins during the growing period of youth, giantism results; if after 25, acromegaly is produced. When "F." stretched out his arm at right angles to his body, the writer (height 5 ft. 11 in.) could walk comfortably under it. "F." knew that giants died young, and his ambition was to live long enough to outgrow the Chinese giant, who, he said, was 8 ft. 4 in. in height. So far he had had no serious illness. His sexual organs were normal. He had no pressure symptoms in his brain, and these were not to be expected, as an x-ray photograph showed a pituitary fossa quite normal in shape. All his bones were overgrown in breadth as well as in length, and the soft structures of the body were similarly affected; nor is this surprising as far as the muscles are concerned, when it is remembered that biologically bone is secondary to muscle and not muscle to bone. Three excellent skiagrams were taken for me by Dr. A. C. Norman, and I append a description of each:



Giant "F." with a man of ordinary height standing beside him.

1. *Skull*.—The sella turcica—like a capital U in shape—admits two-thirds of a skilling in the antero-posterior plane, whilst that of an ordinary skull will admit only a threepenny piece. The greatest length from chin to occiput is 12½ in. From forehead to occiput measures 9½ in. The thickness of the skull in many places measures ½ in., and at the external occipital protuberance ¾ in. The air-containing sinuses are very large, especially the frontal, which measures 7 in. antero-posteriorly. The lower jaw is huge.

2. *Forearm and Wrist*.—The inferior extremities of the radius and ulna are not yet joined to their respective shafts as they should be at the age of 20. His limbs are, therefore, still growing.

3. *Hand and Wrist*.—From the wrist-joint to the tip of the middle finger measures 11½ in. The greatest breadth of the hand at rest at the head of the first metacarpal bone measures 6 in. The parts of the hand are proportionate. His thumbnail is 1½ in., and that of his middle finger 1 in. in length. Ossification: (a) The heads of the inner four metacarpals are joined to their respective shafts, and so is the base of the thumb metacarpal to its shaft, as they all should be at the age of 20. (b) The bases of the first and second rows of the phalanges are not yet united to their shafts as they should be at 20; but those of

the third row are as they should be at his age. The fingers and the thumb are evidently still growing.

"P." had an average intelligence and was not ungainly, though most giants are said to have been dull, feeble, ungainly, and short-lived. Magrath, 7 ft. 5 in., died in 1760 at the age of 24. Chang, the Chinese giant, was an exception, and so was the Russian, Machnow, who at 23 measured 9 ft. 3 in., and was well proportioned. He was, perhaps, the biggest of modern giants. Byrne measured 8 ft. 4 in. after his death, which took place at 22. Og, the king of Basan, was handsome (Josephus), and his iron bedstead was 13 ft. 6 in. by 6 ft. Goliath of Gath was 9 ft. 6 in., or according to Josephus 8 ft. 9 in., and his hand was big, for "the staff of his spear was like a weaver's beam." Classical evidence of giants measuring 46 and even 60 cubits is mythical and untrustworthy. The Scriptural evidence of races of giants does not amount to much. The two Hebrew words translated "giants" in the Authorized Version and "nephelim" and "mighty men" in the Revised Version did not apparently apply to giants in our sense of the word.

Even the celebrated naturalists Curvier and Buffon fell into the popular delusion of there being "giants in those days" by figuring the fossil bones of elephants, rhinoceroses, mastodons, etc., as remains of human giants. Nevertheless human skeletons of extraordinary size have been found in the caves in the "Red Rocks" of Mentone, where they measured 6 ft. 6 in. in length, and showed evidences of powerful muscular development; and in Scotland, where five such skeletons were found together at Logie Pert, Forfarshire. We must therefore admit that giantism may be racial as well as the result of disease. The tallest men now living in the British Isles are said to be the villagers of Balmaclellan, in Galloway, whose average height is 5 ft. 10.46 in. (Dr. Beddoe). The average height of the Tehuelches of Patagonia is only 5 ft. 10 in.

INVOLVEMENT OF THE ORBIT IN DISEASE OF THE NASAL ACCESSORY SINUSES.

BY

ROBERT E. WRIGHT, M.B., MAJOR I.M.S.

ACTING SUPERINTENDENT, GOVERNMENT OPHTHALMIC HOSPITAL, MADRAS.

It is not so very long ago that most cases of orbital cellulitis applying for relief at large ophthalmic clinics were regarded as of unknown origin. Even now the most diligent inquiry often fails to explain the mode of onset in certain cases. It should, however, always be remembered that until the ophthalmic surgeon can prove the accessory sinuses of the nose healthy, he is not justified in looking for a more obscure seat of origin elsewhere. The intimate relation between the orbit and the nasal accessory sinuses is familiar to all. To those who dip slightly deeper, and familiarize themselves with illustrations of the work of Onodi or of others who have for a considerable time drawn attention to this important matter, it must appear strange that extension from infected sinuses to the cellular tissues of the orbit is not more frequent. Probably mild degrees of periostitis are much more frequent and much more serious than is commonly thought. If ophthalmologists have been to blame in the past for accepting orbital cellulitis as a clinical entity, this cannot be said of those rhinologists who of recent years have devoted so much time and labour to the nasal accessory sinuses. Owing chiefly to their researches, it is now a recognized fact that cellulitis of the orbit is nearly always due to accessory sinus disease.

In a large out-patient department like that of the Government Ophthalmic Hospital, Madras, a considerable number of such cases report for treatment. More than half of the cases are children, in whom it is often very difficult to locate the sinus trouble; fortunately in adults it is simpler. In either case the nose should be carefully examined by the usual inspection methods; transillumination should be performed, and, if possible, a good x-ray photograph obtained. In children the sinus disease is more often of a primary acute nature, whilst in adults it is more frequent to meet with an exacerbation of a chronic

condition. It is remarkable how often orbital cellulitis clears up by mere drainage, but it is to be remembered that a certain number of patients come back later with optic atrophy. This note is intended, however, to record the comparative frequency with which one of these sinuses was responsible for cases of orbital trouble reporting to this hospital during the last quarter of 1920. Six cases in all were met with. This is greatly in excess of the average rate at which orbital complications are met with in frontal sinus disease in Madras. The case notes are as follows:

CASE I.

R. P., Hindu male, aged 27, presented himself on September 19th, 1920, complaining of swelling of the left upper lid of three months' duration. His sight was not affected, but he had been troubled with nasal discharge. There was a small, rounded, firm swelling below the middle of the superior orbital rim and marked ptosis. While examining the cyst-like tumour the patient volunteered the information that he could empty it, and proceeded to do so by squeezing firmly upon it and evacuating the contents (about a drachm of mucus) upon the floor. There was tenderness on pressure against the floor of the sinus. The left nasal fossa showed hyperaemia, swelling of the middle turbinate, with polypi and pus in the middle meatus. A frontal sinus probe could not be passed; transillumination was negative. An x-ray photograph showed small symmetrical frontal air sinuses without marked septa. A certain amount of foggy opacity on the left was the only indication of disease. There was no history of syphilis, and the Wassermann reaction was negative. Both fundi were normal.

Drainage by the intranasal route was adopted. The anterior part of the middle turbinate was removed with scissors and snare, and the ethmoidal cells broken down. A large escape of pus occurred on opening the agger cells. As the ostium of the frontal sinus was cleared and enlarged, pus flowed freely into the middle meatus. Drainage was established by enlarging the fronto-basal canal and ostium. Irrigation was subsequently carried out for a short time. The patient left hospital on October 28th, 1920, free from swelling, ptosis or tenderness, and without discharge from the frontal sinus.

CASE II.

R., Hindu male, aged 30, came to hospital on September 20th, 1920, complaining of dull vision on the right side and discharge from the upper lid. R. eye, V. P. at 2½ metres due to old leucoma; fundus normal. L. eye normal. The lid disease commenced three and a half years ago with unilateral headache and offensive nasal discharge. He had interrupted attacks of pain during this time. During one of these, five months ago, a swelling appeared below the brow. He had it opened, and as it would not heal he came to hospital. The sinus led to necrotic bone in the roof of the orbit. Examination of the nose showed polypi and pus in the middle meatus. A frontal sinus cannula could be passed on the left but not on the right. Transillumination was negative. An x-ray photograph showed very extensive frontal sinuses on either side, divided into locally well-marked septa. There were large orbito-ethmoidal cells. The Wassermann reaction was negative, and there was no clinical evidence of syphilis.

The external route was chosen for operation. A Killian's incision was made and the frontal sinus opened at its inner end. The mesial septum between the sinuses was eroded, and a probe could be freely passed through to the temporal region of the left. The left ostium communicated freely with the nose, that on the right was effectively blocked. There was crepitation of the floor of the right sinus and subperiosteal pus over the os planum and lacrimal bone. The orbito-ethmoidal cell was opened and both it and the frontal sinus were put in free communication with the middle meatus. The necrotic inner wall of the orbit was removed. The wound was partially closed, drainage being established from its inner end through the free opening into the nasal fossa. For some time gauze wicks were renewed daily, then irrigation with a frontal sinus cannula was carried out. Clear fluid returned from both sinuses after about five weeks, and he was discharged almost well on November 11th, 1920. In this case the Killian type of operation was adopted, and the trochlea was saved by leaving a bridge. The lacrimal sac had to be removed. The important points in such cases are to establish good intranasal drainage without doing muscular damage, and avoid deformity due to subsequent contraction of scar tissue.

CASE III.

K. M., Hindu male, aged 40, reported on October 16th, 1920, complaining of swelling and pain of the left eye. R. eye, V. 6/18, fundus normal. He gave an unreliable history of the swelling starting one and a half months before. He had no nasal discharge. He denied syphilis, but his wife had a suspicious record. The Wassermann reaction was positive. His right eye was much proptosed, there was extensive swelling of the lid, brow, and root of the nose. There was a pulsating swelling about the size of half an eyeball an inch above the inner end of the right brow. On firm pressure this disappeared and a circular loss of bone could be felt. This gave the patient acute pain, and caused the swelling of the lid to increase. The nasal fossa was so swollen and oedematous that nothing could be made out, even after thorough packing with cocaine and adrenaline. There was obvious bony deformity, and exposed

bone could be felt high up with a soft blunt probe. An x-ray photograph showed large frontal sinuses divided into loculi with a fairly sharp outline on either side. There was a definite general haze round the glabella, but no indication of an opening in the anterior wall of the left sinus. The antra were clear on transillumination.

On October 18th, 1920, the pulsating swelling was opened by a vertical incision and a large quantity of glairy muco-pus escaped. Through this opening the sinuses were explored and were found to reach 2 in. above the orbital rim, and to the external angular processes. The nasal fossa was easily entered with a blunt probe on the right but not on the left. A Killian incision was made. This disclosed a complete absence of the roof of the orbit and extensive caries with the dura exposed above. The nasal fossa was now easily entered on the left. The carious ethmoidal cells were curetted away and a large drainage orifice made into the nose. Gauze wicks were led through from the upper incision and the inner extremity of the lower incision to the nose, and from the body of the sinus to the outer angle of the wound. In spite of careful drainage and vigorous antisiphilitic treatment it became obvious after some time that it was essential to remove the anterior wall of the left sinus and let the skin fall in. This was done on January 7th, 1921, good drainage was established right and left, and after careful curetting the wound was lightly packed. The patient made an uninterrupted recovery. The deformity was, of course, considerable.

CASE IV.

A. C., Anglo-Indian, aged 51, was admitted on October 22nd, 1920, with proptosis of the right eye, with swelling and oedema of the lid and brow, and acute pain. There was no impairment of vision. The first symptoms he noticed were bulging of the eye and double vision. A month previous to this he got a knock on the brow, and a week before exposed himself by sitting up shooting. Shortly after this severe pain started. When seen at hospital he presented a typical picture of orbital cellulitis. An incision was made in the superior fornix and pus evacuated, but this did not relieve the condition, and a fluctuating swelling appeared over the outer third of the eyebrow. Nasal examination revealed oedema of the middle turbinate and pus coming from the frontal sinus. No x-ray photograph was obtained. On November 13th, 1920, the frontal sinus was opened by the intranasal route. This did not relieve the condition, and a week later the external operation was done. There was caries of the orbital rim and a large pocket of pus under the periosteum of the orbital roof, which was perforated and opened into the frontal sinus. The latter was small and communicated with the superior meatus with a very angular fronto-nasal duct. Free drainage was established into the middle meatus, and gauze drains led through. About a month later a large sequestrum was removed from the outer part of the orbital rim. The patient frequently complained of severe neuralgic pain. In spite of a negative history of syphilis and a negative Wassermann reaction he was put on mercury and iodides. He improved steadily, but still complained of supraorbital pain. He was discharged at his own request, without diplopia, and with diminished proptosis, but there was considerable interference with the movement of the upper lid due to adhesions to the periosteum at the orbital rim.

CASE V.

This was a case of very extensive ulceration of the orbit and frontal sinuses, due to gummatous disease, superimposed upon which was myiasis. This case has already been fully recorded, as it was of interest also from an entomological point of view, the adult flies having been hatched out from the maggots.¹

CASE VI.

M. R., European, aged 42, was admitted on December 31st, 1920, complaining of acute supraorbital pain on the left side, which had prevented him from sleeping for some time. He had very slight swelling of the lid and thickening of the supra-orbital nerve. There was pain on pressure against the orbital rim and the nerve was excessively tender. The vision was 6/5 for both eyes and the fundi were normal. There was a negative history of syphilis, no clinical signs, but a positive Wassermann reaction. An x-ray photograph was not obtained. Transillumination was negative. He gave a history of a very severe fall from a motor bicycle five months before, with temporary unconsciousness and bleeding from the ear. The exact location of the latter was somewhat uncertain, and he had a perfectly normal drum. There was no history of influenza or acute catarrh. The nasal fossa looked healthy, but on passing a cannula into the fronto-nasal duct a small quantity of muco-pus was evacuated. He was given an injection of novocain, followed by alcohol, into the supraorbital nerve, which relieved his pain. On December 31st, 1920, the anterior end of the middle turbinate was removed with scissors and snare and the ostium of the frontal sinus enlarged. The anterior ethmoidal cells were also broken down. He developed a third nerve paralysis three days after operation. He was put on injections of mercuric cream and novarsenobillon on alternate weeks and rapidly got better. On January 21st, 1921, the paralysis had almost gone and there was no diplopia. He had no pain and his nasal fossa and sinus were apparently healthy.

REFERENCE.

¹ *Indian Medical Gazette*, February, 1921, p. 58.

THE ISOLATION OF DIPHTHERIA BACILLI.

BY

DENYS R. WOOD, F.I.C.,

PUBLIC ANALYST AND BACTERIOLOGIST, SOMERSET COUNTY COUNCIL.

It is sometimes necessary to obtain the diphtheria bacillus in pure culture in order to test its pathogenicity, as, for instance, when found in swabs taken from lesions other than the throat and nose, such as the ear, the eye, and sores on other parts of the body, and occasionally from the throat and nose also in the case of very persistent carriers.

A useful medium for this purpose is described in Browning's *Applied Bacteriology* as follows:

Sheep serum, sterilized by heating on several occasions for one hour at 57° C.	5 c.cm.
1 per cent. telluric acid in distilled water	0.9 c.cm.
Peptone water agar (roughly neutral to litmus) to	100 c.cm.

The serum and telluric acid solution are added to the melted agar at 50° to 55° C. before pouring into Petri dishes.

In my experience sheep serum, when the blood is obtained from the abattoir, is seldom sterile when heated at 57° C. for one hour on seven or eight consecutive days, and the ether and chloroform methods of sterilization are equally unreliable, in fact, the only reliable method appears to be filtration through a Chamberland filter. It is therefore a great advantage to be able to dispense with this constituent.

Diphtheria bacilli grow exceedingly well on Gordon and Hine's legumin tryptagar,¹ and when this medium is used no sterile serum is necessary. The addition of 0.3 c.cm. of sterile 1 per cent. telluric acid to 10 c.cm. of this agar gives a very satisfactory medium. Plates of this medium are poured, and when set brushed with a dilute emulsion of the growth containing the diphtheria bacilli and incubated at 37° C. for forty-eight hours, by which time the characteristic appearance of the colonies of the different organisms is most distinct.

The majority of organisms other than the diphtheroids reduce the telluric acid and produce blackish colonies; this is very marked with the staphylococci. The streptococci do not reduce the telluric acid, their colonies are characteristically greyish-white, small (usually less than 1 mm. diameter), very flat and very translucent. The colonies of the diphtheroids are greyish-white, semi-translucent, slightly convex, about 1 mm. in diameter, with a slightly darkened central spot. By the use of this medium I have selected as many as five colonies of *B. diphtheriae* in succession from a plate containing numerous colonies of other organisms.

The morphology of the diphtheria bacillus when grown on legumin tryptagar differs from its morphology when grown on Loeffler's serum; the bacillus stains more uniformly, the characteristic beads are not evident, and club-shaped forms are common. With a little practice, however, it can readily be recognized and distinguished from Hoffmann's bacillus grown on the same medium. It is unfortunately not possible to distinguish between the colonies of Hoffmann's bacillus and those of true diphtheria bacilli. Douglas's trypsin broth² with the addition of pea-flour extract and 0.5 per cent. Witte's peptone (to help toxin production), is very suitable for the cultivation of *B. diphtheriae* for animal inoculation. Almost invariably a good growth is obtained—an essential condition of the experiment—while with ordinary broth this is far from being the case, the growth more often being only scanty. Glucose litmus legumin trypsin broth is very suitable for the observation of acid productions from this sugar.

REFERENCE.

¹ Vide BRITISH MEDICAL JOURNAL, November 18th, 1916; also Reports of the Medical Research Council, Special Report Series No. 19. ² Loc. cit.

A SMALL Italian surgical hospital with an out-patient department has been opened at Aleppo by the National Italian Association.

THE sixteenth Congress of the German Orthopaedic Society will be held in Berlin from May 18th to 20th, when the principal subjects for discussion will be bone and joint tuberculosis and rickets.

Memoranda:

MEDICAL, SURGICAL, OBSTETRICAL.

PREVENTION OF INTESTINAL OBSTRUCTION AFTER VENTROFIXATION.

In the *Epitome of Current Medical Literature* of the *Journal of February 12th* there occurs a paragraph (No. 216) on "Intestinal Obstruction after Ventrofixation of the Uterus," by Hastrup, from *Ugeskrift for Læger* of December 30th, 1920. After losing a patient, on whom I had operated, owing to obstruction of an intestinal loop, I have always closed the space between the retroflexed

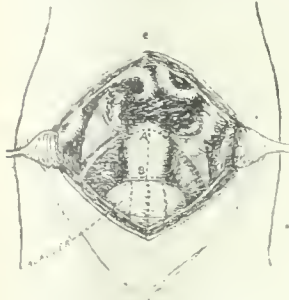

FIG. 1. The vertical dotted line A is on the uterus, with flaps at A and B to show flaps of peritoneum reflected. Curves and knots above show the lines of suture of uterus to bladder and abdominal wall (cautery). Two or three strong silk-worm-gut sutures fix fundus above A to wall.

uterus and the bladder before fixing the uterus, in the following way: The whole of the bladder surface of the body of the uterus, from the fundus down to the line of reflexion of the bladder, is bared of its peritoneal covering by dissecting back two flaps as in the figure. At first I dissected similar flaps on the bladder, but this part was more difficult and is not necessary. The bared uterus is next united to the bladder and peritoneum above by central catgut sutures. These are of fine gut, and care must be taken not to put the bladder sutures too deep. A continuous catgut suture

next unites the dissected flaps all round from bladder reflexion on one side to the other over the fundus. The rest of the operation is done in the usual way.

I have had only one opportunity of seeing the late result, and there instead of the usual band there was a broad ligament supporting the uterus. There has been no return of prolapse, though usually no vaginal operation has been done, and several have borne children with no difficulty, and no return of the prolapse. I have no doubt others will have done the same operation, but from the abstract in the *Epitome* the method does not seem to be well known. It can, of course, be combined with operative treatment on the round ligaments, but I have not considered both necessary.

Aberdeen.

ALEXANDER DON, C.M., F.R.C.S.Ed.

AMOEBIĆ DYSENTERY COMPLICATING MALIGNANT DISEASE OF THE LOWER BOWEL.

The following case is of some interest from the fact that *Entamoeba histolytica* was found microscopically four months prior to death from carcinoma of the pelvic colon.

C. L., a ship's painter, aged 41, who had never been in the tropics, was admitted to Queen Mary's Hospital for the East End on October 10th, 1920, suffering from diarrhoea with blood and mucus. He first had diarrhoea and colicky pains four months previously, but he continued work down to three weeks before admission. His physique was good, but he appeared slightly anaemic; the tongue was slightly furred; he had an upper denture, the lower teeth were good, and he had no lead line on the gums. The heart and lungs were normal. The abdomen was rather full and tympanitic, with tenderness in the left iliac fossa. The liver and spleen were not enlarged nor tender; there was no pain on micturition. Urine, specific gravity 1022, acid, and free from albumin. The stools were pale and watery, containing large jelly-like masses and shreds of blood-stained tissue. Temperature 98.6, rising to 99.2 in the evening. The bacteriologist reported the presence of free amoebae of *E. histolytica* type. Plates were negative for *B. dysenteriae*. Sigmoidoscopic examination showed the mucous membrane pale, but no ulceration or inflammation of bowel within 9 m. of anus.

Emetine bismuth iodide, grains 3, was prescribed; twelve doses were taken from October 18th to October 30th; the lower bowel was irrigated with ensool, half-strength, daily. The condition did not materially improve, and two courses of emetine hydrochloride injections, gr. 13, were given in November and December. On December 12th the bacteriologist reported that the stools were very fluid, without blood or mucus; no amoebae or cysts were found, and there was no cellular exudate.

The diarrhoea persisted with occasional mucus and blood, and the patient was losing weight and becoming cachectic, de Morgan spots were seen on the body, the skin was atrophic, and the tongue furred. Rectal examination showed ballooning, but no growth could be felt. The abdomen, when examined on January 12th, 1921, was soft and flabby with wasted muscles; a firm nodular tumour the size of a Tangerine orange, slightly movable, but adherent to the pelvic structures, was palpable just above the pubis. The lower edge could not be reached. Laparotomy was performed by Mr. Cousins on January 14th. A large malignant mass was found in the lower abdomen involving the descending and pelvic colon, a loop of small intestine, and the base of the bladder. An anastomosis of the small gut into the transverse colon was performed and the abdomen closed. Later there was some amelioration of the symptoms, but death occurred on February 16th.

The autopsy revealed a large malignant growth encircling the bowel about ten inches from the anus, extending upwards and involving about four inches of large bowel. The primary growth showed necrotic changes, and numerous elongated shreds of growth, with which was mixed dark clotted blood. No mucus was discovered. A coil of small intestine three feet above the caecum had become invaded by growth and its lumen almost occluded. The primary growth encircling the large bowel had not caused obstruction. The growth was adherent to the bladder but had not ulcerated through. Secondary deposits were found in the mesentery of the small bowel but not in the liver. The anastomosis was soundly healed and functioning. The liver showed fatty changes and was very bile-stained. There was no jaundice.

I consider that the malignant disease was not of recent origin, and that it was present at the time he had his first symptoms, seven months before death. The amoebic dysentery was merely a complication, and probably had no bearing on the causation of the growth. However, the fact that *Entamoeba histolytica* was found four months before death made the case unusual and obscured the real diagnosis. I have to thank Dr. Troup, under whom the patient first was, and Mr. Cousins, for their kindness in allowing me to publish this case.

JENNER HOSKIN, M.R.C.P.,
Hospital Physician, Queen Mary's
Hospital for the East End.

Reports of Societies.

DIGESTION OF THE OESOPHAGUS.

At a meeting on March 18th of the Royal Medico-Chirurgical Society of Glasgow a communication was made on "Digestion of the oesophagus as a cause of post-operative and other forms of haematemesis," by Mr. J. HOGARTH PRINGLE, Dr. LAURENCE T. STEWART, and Professor J. H. TEACHER. Post-operative haematemesis, they said, was a symptom of great importance to the practical surgeon, and associated with serious danger to the patient. In recorded cases various explanations were given, but digestion of the oesophagus was not mentioned. A few cases of *intra vitam* oesophagomalacia and ulcer a digestion had been recorded, and in July, 1914, Glynn demonstrated to the Pathological Society of Great Britain and Ireland sections of the oesophagus which showed ulceration and inflammatory reaction.

Prior to January, 1914, one of the authors had seen two cases of destruction of the lower part of the oesophagus which looked as if this might have commenced during life. Then a case occurred, under the care of Mr. Pringle, in which vomiting of brown material was observed after operation and about thirty-six hours before death. There was also complaint of pain behind the sternum. No cause of these symptoms except digestion of the oesophagus (which had not gone the length of perforation) could be made out, and the observation then ceased to be a pathological curiosity and became a matter of practical importance. In 1919 the authors made a communication to the *British Journal of Surgery* (vol. vi, No. 24, p. 523) on this subject in which they described a number of cases in which digestion of the oesophagus appeared to have been the cause of haematemesis or vomiting of brown or black material and in some cases the cause of death. Several of the cases in the series were not surgical but medical cases—for instance, anthrax, pneumoemia, puerperal eclampsia. On clinical and morbid anatomical grounds the digestion of the oesophagus was regarded as a vital phenomenon. Sections from a number of these cases were shown to the Pathological Society at the meeting in Leeds in January,

1921, and full publication would later be made in the *Journal of Pathology and Bacteriology*.

Intra vitam digestion of the oesophagus was supposed to arise in the following manner. Vomiting of active gastric juice occurred, but the oesophagus failed to clear itself and some of the fluid remained in it, accumulating particularly just above the cardiac sphincter, in which region the injury to the tube was usually most advanced. In post-operative haematemesis the fluid ejected was usually extremely acid, and those patients who were sufficiently conscious to be able to express themselves frequently complained of the scalding effect which it had upon the throat and lips. The lesions produced before death by gastric juice which has escaped into and lain in the oesophagus were apt to be more or less obliterated by changes due to continuation of the digestion after death. In twelve of the fifteen cases which were described in 1919, and in four new ones, however, microscopic examination had revealed unmistakable signs of vital reaction, in the form of abundant leucocytic infiltration of the mucous membrane and other tissues, congestion of blood vessels, accumulation of leucocytes in the vessels, thrombosis, and inflammatory oedema. The picture was that of an acute ulceration. It was easier to recognize these changes than to assess the extent to which they might have been obscured or obliterated by continuation of digestion, or to decide the relative amounts in which that digestion was a continuation of the lesion which developed during life or a *post-mortem* change. Probably these cases had been observed, but the lesions had been put down as merely *post-mortem* digestion, from which, however, it was not now difficult to distinguish them. It was therefore clear that digestion of the oesophagus during life did occur; that it might be the cause of death; that it occurred in other than operation cases, and that it might be arrested and healing take place. Its occurrence was shown by haematemesis, and in some cases by pain behind the sternum. It was therefore open to diagnosis and in some cases at any rate must be amenable to treatment. The commencement of healing had been recognized in two specimens.

In most of the cases recorded in the *Journal of Surgery* the digestion probably began not more than thirty-six hours before the death of the patient; in some cases the duration was much less, reckoning from the occurrence of the haematemesis. The morbid anatomy of the cases showed great variation—from a slight condition in which the phenomena were superficial erosion of the mucous membrane, with haemorrhages into the affected tissue and black fluid in the oesophagus, to cases in which perforation or extreme maceration of the lower third of the oesophagus and extensive digestion of the adjacent surfaces of the lungs had taken place. Nine examples of the most advanced type, five severe but not perforated, and five slighter lesions had been observed—seventeen of them since January, 1914. A most important diagnostic feature available at autopsy was the relatively slight change in the stomach, which might show only slight *post-mortem* digestion or a total absence of that condition, contrasting with advanced digestion of the oesophagus immediately above the cardiac ring. In most cases, at least of the severer types, there was a well marked zone of deep ulceration immediately above the cardiac ring. At a varying distance above this the changes were less of the nature of destruction, the predominant features being superficial erosion and haemorrhages into the mucous membrane, such as were seen in the slight cases. Signs of reaction might be unrecognizable or very slight in the lower parts, but well marked in sections prepared from the upper parts of the damaged oesophagus.

The communication was illustrated by specimens, sections, and lantern slides.

Mr. J. MILL RENTON read a paper on "The surgical treatment of sciatica," which is published in full in our issue of this week, at page 557.

Mr. G. H. EDINGTON read a short account of two cases in which the thoracic duct was wounded in the operation for removal of tuberculous cervical glands:

Case 1.—Early in 1911 he operated on a boy, aged 7, for tuberculous cervical glands involving an extensive dissection on the left side of the neck. The thoracic duct was not seen, and there was nothing unusual in the appearance of the wound at the conclusion of the operation. There was post-operative rise of

temperature to over 100 F., and in thirty-six hours the dressing began to be soaked with watery discharge. On the fourth day the wound was opened and fluid sponged out, and the welling of fluid had ceased, but the internal jugular vein was found to be very fragile. There was no pus in the wound, and the muscles were peculiarly clean and bare. Death took place on the night of the sixth day, with a copious flow of blood from the wound.

Case 2.—In the summer of 1920 he operated on a lady aged 28. Extensive dissection on the left side of the neck was required, but the thoracic duct was not identified. The following day there was copious watery discharge, and two days later there was ballooning of the lower part of the neck, and through the lower incision there spouted fluid like whey of a pale greenish colour. The temperature rose to 101° F., and as milky fluid continued to pour out, the cavity in the posterior triangle was packed with gauze. The tissues in this case also were macerated. After the firm packing of the posterior triangle the milky discharge became gradually less, and the wound healed without further event.

In the discussion that followed, Mr. ARCHIBALD YOUNG recorded a third case of a man, aged 52, whom he operated on in 1910 for a very extensive tuberculous involvement of the cervical glands on the left side.

Dissection of the glands was carried out laboriously and with much difficulty, and the sterno-mastoid muscle, part of the parotid gland and part of the internal jugular vein were removed in course of the operation. During the operation Mr. Young became aware, through soaking of his gown and the sheets on the operating table with a glairy, sticky fluid, that injury of the thoracic duct had taken place. An attempt was made to find the injured duct, but without success, and in the end recourse was had to packing with iodoform gauze. From the time of the operation there was no further escape of chyle, and on the removal of the packing, which was not disturbed for several days, it was found to be soaked with serum only. The recovery was uneventful.

INDICATIONS FOR BLOOD TRANSFUSION.

At a meeting of the Liverpool Medical Institution held on March 31st, with the Vice-President, Mr. THURSTAN HOLLAND, in the chair, Mr. W. BLAIR BELL discussed the indications for blood transfusion, giving illustrative cases. He divided the conditions for which blood transfusion is required into three main groups with subdivisions.

Group A contains those cases in which there is loss of all the constituents of the blood from an acute large haemorrhage, or the loss of the solid constituents which occurs in chronic limited haemorrhages, or in which there is considerable loss of fluid associated with shock. *Group B* contains those cases in which there is absent from the blood some constituent present in normal circumstances, or one usually formed in response to specific stimulation. In this group are such conditions as haemophilia, in which disease operations may safely be performed immediately after blood transfusion. Included also are cases of eclampsia, in the blood of which a chemical antibody to placental toxin is believed to be absent, and acute and chronic infections in which the patient's own bacterial antibodies are insufficient. *Group C* contains those diseases in which there is blood destruction. Although good results are claimed for the treatment by blood transfusion of pernicious anaemia, it is probable that the result is only temporary and that transfusion must often be repeated.

A short account was given of the blood grouping of donors of blood and of the problems which may be connected with the grouping, such as the heteroplastic grafting of tissues and selective sterility. Mr. Blair Bell discussed finally the various methods of blood transfusion, and emphasized the fact that the citrated blood method is the only generally applicable and safe procedure. He then described his own apparatus by means of which the blood of the donors is automatically citrated as it leaves the vein, and all the fluids are kept at body temperature during the necessary steps in the operation. He demonstrated this apparatus to the meeting.

Dr. JOHN HAY read a paper dealing with the prognosis in patients presenting a rapid heart action. Patients with rapid action of the heart could be classed in two groups: (1) those in whom the rhythm was physiological, and (2) those in whom it was pathological. In the first group the rapid action was secondary to such causes as emotion, effort, toxins, etc., and the prognosis depended on an accurate recognition of the primary cause. Special reference was made to the rapid action in patients suffering from aortic regurgitation and also to the apyretic tachycardia of early tuberculosis. The combination of

functional and organic diseases of the heart was discussed. In the second group three conditions were briefly discussed: paroxysmal tachycardia, auricular flutter, and auricular fibrillation, and typical cases were described. The prognosis, both immediate and remote, was carefully considered in each patient and the general principles defined on which prognosis depended.

A NEW ANAESTHETIC.

At a meeting of the Section of Anaesthetics of the Royal Society of Medicine, held on April 1st, with Dr. H. J. SHIRLEY, C.M.G., President, in the chair, Dr. R. L. MACKENZIE WALLIS and Dr. C. LANGTON HEWER read a paper on a new general anaesthetic, its theory and practice. Dr. Wallis described the impurities of ordinary ether and previous efforts at the production of ether free from impurities to which harmful effects may be attributed. He alluded to the work of Cotton and to the uselessness of absolutely pure ether as an anaesthetic. The ether which he has prepared, after many different processes had been tried, is distinguished by being free from mercaptans, while it contains the higher ketones, some carbon dioxide, and some ethylene, perfectly pure ether being the vehicle. In the production of this pure ether, permanganate and copper sulphate are employed. The new ether keeps better than the ordinary liquid. The carbon dioxide appears to exercise a stabilizing influence.

Dr. HEWER said that the new agent was less irritating than ordinary ether and stimulated the respiratory system less. He had used it on the patients suffering from bronchitis, none of whom suffered any aggravation of their symptoms. The blood pressure effects were between those of chloroform and of ether. The drop after operation and before consciousness was less than with ether. It had been used successfully on patients with diseased hearts. No ill effects had followed its use with three diabetic patients and with a child who was passing large amounts of acetone. There was absence of taste and smell afterwards and much less liability to vomit. The methods employed had been those usual with ether. Mostly he had used the new agent in connexion with continuous gas and oxygen. It is made by Savory and Moore under the name "ethanesal." Subsequent speakers bore testimony to the satisfactory anaesthesia and freedom from after-effects which they had experienced with ethanesal. It had been used in about 250 cases.

At a meeting of the Laryngological Section of the Royal Society of Medicine on April 1st, with Dr. JOHNSON HORNE in the chair, Mr. ARCHER RYLAND gave an epidiascopic demonstration illustrating a case of pharyngeal pouch dated 1760. Some members doubted whether it was a true pharyngeal pouch, as it was covered by muscular fibres, so that it might more accurately be regarded as a dilatation of the lower part of the deep pharynx. Mr. G. W. DAWSON showed a case of large dental cyst. In the discussion, Mr. STUART LOW doubted if it would heal up without further treatment, and suggested painting the cavity with strong zinc chloride. Dr. DAN MCKENZIE thought that a plastic operation would be necessary. Mr. DAWSON also showed a girl with a retention cyst of the floor of the left nostril. Mr. C. W. M. HOPE showed a patient with a tumour growing from the right supratonsillar fossa. It was agreed that this was probably composed of ordinary tonsillar tissue, and several similar cases were cited. Dr. DAN MCKENZIE showed a case of scarring of the pharynx following scarlet fever many years before, the uvula being moved by contraction to the right side of the palate. Mr. M. VLASTO showed a case of bilateral abductor paresis of the vocal cords. Several members advocated tracheotomy, and Mr. F. HOBDAY, as a result of his veterinary experience, suggested an operation similar to the ventricle stripping performed on "roaring" horses. Mr. PHILIP FRANKLIN showed a case of demicyclops, or lateral nasal proboscis, in a male infant 7 weeks old, and demonstrated the embryological abnormality that had probably occurred to account for the condition. The main points that he called attention to in the case were the absence of the premaxilla, the movement of the appendage, the perforation of the free end, and the secretion of salty fluid. Mr. JEFFERSON FAULDER showed two laryngeal cases for diagnosis, in both of which there was a tumour springing from the region of the ventricular band. They were thought, after some discussion, to be non-malignant.

Reviews.

THE PHYSIOLOGY OF BONE.

IN his treatise on *Bone Formation*¹ which Dr. MURR JANSEN of Leyden has done us the compliment to write in English, he advances very convincing evidence that tension does not exert any trophic influence on bone. His contention is the result of a careful and extensive study of sections, taken in various planes, of normal and abnormal bones, and his interpretation of the conditions observed prove that he has a very keen appreciation of the close affinity between structure and function.

It is shown, from a study of the neck of the femur in coxa vara, that there is a contrast between the effect of pressure which leads to thickening of the bone elements and tension which produces a thinning of the same elements. A similar contrast is demonstrated in normal bones from several parts of the body and in other pathological conditions. Dr. Jansen explains how previous workers in this field have erroneously ascribed the formation of bone to tension stresses, without taking into account dynamic stresses evoked by muscular action, and cites several examples which show that tension has been assumed in parts of bones exposed to pressure from muscular action.

After surveying the relation of function to the structure of the cancellous tissue in various parts, the author concludes that it is composed of bone elements which coincide with pressure stresses caused directly by muscular action and body weight: and he brings forward evidence to prove that wherever pressure is displaced by tension, atrophy of the cancellous tissue is found. Throughout the book just and arresting criticism, supported by original observations, is levelled at the assumption that tension may promote bone formation. It appears clear that too great emphasis has been laid in the past upon the effect of the purely mechanical forces acting upon bone, and Dr. Jansen undoubtedly brings us back to the living bone and its function: for this reason a study of *Bone Formation* is both refreshing and stimulating, and its facts and arguments will prove of great interest and importance to a wide circle of readers. It is a book from which all anatomists, physiologists, and surgeons may gain inspiration, and even if only a proportion of its readers are prepared fully to accept the doctrine that "to pressure only a trophic effect on bone tissue has been assigned," all will find themselves influenced by the striking and significant observations made, and be stimulated to look a little deeper into the orthodox teaching on this subject. The book is well and freely illustrated, and a credit to the publishers.

DISEASES OF CHILDREN.

IN the third edition of his well known book, *The Clinical Study and Treatment of Sick Children*, Dr. JOHN THOMSON has taken the opportunity of rewriting the whole and of reviewing all that is best in paediatric literature during the last ten or twelve years. It is quite evident that Dr. Thomson has read very extensively, and that nothing of value has escaped his notice. There may be other books published in this country which make reference in more or less detail to the great and increasing literature—British, Continental, and American—of this department of medicine, but there is no other that provides the reader with the opportunity of seeing it passed in review by a teacher so experienced and of such ripe judgement. For example, Chapter XXII, entitled "On Spasmophilia," gives an admirable account of a condition which, for want of separate consideration has been somewhat obscured in textbooks published in this country. The contents of Chapter IX, "On Food Disorders," are subdivided as follows: "Work of Czermy and Keller, and of Finkelstein; Finkelstein's classification: stages of disturbance of equilibrium, dyspepsia, decomposition and intoxication. Causes, symptoms, treat-

¹ *On Bone Formation: Its Relation to Tension and Pressure.* By Dr. Murr Jansen, O.B.E., Lecturer on Orthopaedic Surgery, University of Leyden (Holland). Manchester: The University Press, 1920. (Roy. 8vo, pp. 114; 54 figures, 20s. net.)

² *The Clinical Study and Treatment of Sick Children.* By John Thomson, M.D., F.R.C.P., Edin. Third edition, rewritten and greatly enlarged. Edinburgh and London: Oliver and Boyd, 1921. (Med. 8vo, pp. 507; 249 figures, 32s. 6d. net.)

ment. Digestive disturbances from other causes. Diarrhoea from defective nursing; from infection, enteral and parenteral (causes, diagnosis, treatment). "Idiosyncrasy for cow's milk." This cosmopolitan outlook is a feature of the book which is very welcome.

Dr. Thomson's sober review of these matters will help to break a way through the strange barrier which seems to exist between the literature of this country and that of others in the subject of paediatrics. In its treatment of the great volume of recent work by English authors the book is no less satisfactory. Chapter XXIV, "On the Heart and Circulation," admirably combines the new learning and the old. References to original papers are provided throughout (in footnotes). The value of the book, however, is much greater than that of a review, however judicious, of current literature. It bears the impress on every page of the author's long experience and great powers of observation. Moreover, Dr. Thomson has succeeded in presenting his material in a form which differs from that which has become stereotyped by its adoption in a long succession of textbooks. While it contains all that a student or practitioner may expect to find in it, the book is truly, as its title indicates, a series of clinical studies.

A lifelong study of the ailments of children enables the author to use very clear and convincing language upon many matters which have not before been made plain. Thus it is usually taught that asthma is not a common disease in early childhood. Upon page 54 is a diagram showing the age of onset in 100 cases. In 60 per cent. the onset was within the first four years of life, in 86 per cent. within the first seven years, in 12 per cent. the disease was already established within the first year. Again, the author makes plain the very great improvement which may be looked for in many cases of spastic diplegia due to cerebral birth injury—cases in which the stiff expressionless face, the speech defect, and the constant dribbling of saliva have given rise to an exaggerated estimate of the degree of mental impairment present. With both of these statements we are in hearty agreement. We believe that it might reasonably be argued that in asthma we have, in most cases, a perpetuation of an infantile neuro-muscular inco-ordination, the disappearance or persistence of which is in great measure determined by the success or failure of the disciplinary and moral education of the child, and that the cerebral damage which gave rise to the spastic diplegia, in many cases, produces only a motor defect, leaving the receptive side of the brain unimpaired, although for long unstimulated because of the motor abnormality.

In a book so full of clear and precise, though guarded, statement there is little which invites criticism. We doubt if it is true that "a child should not usually be allowed to bathe in the sea until he is six or eight years old"; but perhaps Dr. Thomson has in mind the frigid seas of his own east coast of Scotland. We think that the short paragraph entitled "Practical Details regarding Breast Nursing" might profitably have been expanded into the most important chapter in the book. The numerous illustrations are excellent. Such plates as those illustrating "The facies in pleuropneumonia before and after the crisis" (p. 7), "Chorea at the onset and in convalescence" (p. 590), and "Nodules in the scalp in rheumatic fever" (p. 735), are an advance upon what is commonly achieved.

Dr. Thomson's book will be of real service to the practitioner and to the student of medicine. So long as the subject of paediatrics is crowded out of the medical curriculum, we must look to books such as this to repair the damage, and, so far as may be possible, to keep alive interest in and to spread understanding of a subject of unequalled importance to the community and the race.

TREATMENT OF VENEREAL DISEASE.

The fourth edition of Marshall's *Syphilis and Venereal Disease*³ appears under the joint authorship of C. F. MARSHALL and E. G. FRENCH. The book has been thoroughly revised throughout and much new matter

added, especially in the sections dealing with treatment. New plates have been inserted and the work is well illustrated, although we should have welcomed a few more illustrations in the chapters devoted to syphilis of the eye and of other special regions of the body. In discussing treatment the authors make a special plea for the internal administration of mercury, a method that has been disparagingly referred to by some writers as the "pill treatment." They point out, in support of their views, that:

The two syphilologists who have probably treated the greatest number of cases—Sir Jonathan Hutchinson and Professor Alfred Fournier—employed this method in the great majority of their cases. Further, as these two syphilologists have enjoyed an unusual span of active professional life, they have been able to follow up their cases to an extent which is denied to most of us and have shown that the proportion of tertiary syphilis occurring among their cases after prolonged internal treatment is small, and compares favourably with that of other methods. In fact, the most reliable statistics we have concerning the frequency of tertiary syphilis (those of Fournier) are based on cases which were, for the most part, treated by ingestion. Hence the incidence of tertiary syphilis appears to depend less on the method than on the duration of mercurial treatment.

In the section describing exfoliative dermatitis resulting from arsenical preparations the authors consider cold or exposure an important etiological factor. During several years' experience in India and London only four cases of severe dermatitis were observed, but during service in France some twenty cases came under observation. The authors suggest that the majority of these cases were due to exposure to cold. They do not, however, give details as to the amount and intensity of the treatment to which these patients had been subjected. Intramine is recommended as the best remedy available for such cases. In the chapter on inherited syphilis several of the illustrations are reproduced from Findlay's excellent little work on *Syphilis in Childhood*. A chapter is devoted to the subject of chancre. In the difficult matter of treatment the authors recommend the method of Goubeau. This form of treatment was extensively carried out in the French army and apparently with success. It consists of carefully cleaning the surface of the chancre with a swab soaked in ether and of afterwards applying by means of a brush or a wooden probe wrapped in wool a 1 in 50 alcoholic solution of sodium arsenate.

In the chapter on gonorrhoea the illustrations are mainly taken from Luys's well-known work on that subject. The important question of tests for cure scarcely receives the attention it deserves, only a few lines being devoted to a subject which is surely one of the most vital in the whole of venereal disease.

In the final chapter, on venereal disease and public health, the authors come to the conclusion that among the measures calculated to reduce the incidence of venereal disease in the community prophylaxis is of primary importance.

THE QUANTITATIVE STUDY OF METABOLISM.

ALTHOUGH long before the war the quantitative study of metabolism had been enriched by the contributions of many physiologists, it is certain that the war-time stringency of food conditions encouraged many to undertake this kind of research who were previously deterred both by the apparent difficulty of the technique and the improbability of attaining any results of dramatic interest. But the researches of Haldane, Pembrey, and Douglas had placed at the disposal of the investigator a method which did not involve the provision of a large quantity of expensive apparatus, and which could be accurately employed by any person who had had a general scientific training and a few months' special instruction. The system to be recommended was succinctly described by Cathcart in a paper which appeared in the *Journal of the Royal Army Medical Corps*, November, 1918, and several English workers reported observations upon the metabolism of healthy adults under varying conditions. For the most part, the circumstances in which these observations were made precluded accurate study of the basal rate, a function which has been elaborately measured by American physiologists, although Cathcart and Orr were able to report upon the post-absorptive rates of a sample of healthy adults. It was obvious that variations of the basal rate in health and disease would repay further investigation, and Drs. BOOTHEY

³ *Syphilis and Venereal Diseases*. For Students and Practitioners. Being the fourth edition of *Syphilology and Venereal Disease*. By C. F. Marshall, M.D., M.Sc., F.R.C.S., and E. G. French, M.D., Ch.B., F.R.C.S. Edin. London: Baillière, Tindall, and Cox. 1921. (Demy 8vo, pp. 446; 90 figures, 9 plates. 25s. net.)

and SANDIFORD⁴ have been well advised to issue a manual for the service of those who wish to introduce calorimetry into the sphere of clinical research.

The authors have had wide experience of clinical calorimetry at the Mayo Clinic, and remark that: "In the treatment of the large number of thyroid cases seen at the clinic our results have definitely shown how essential is the knowledge of the basal metabolic rate in pathologic conditions of the thyroid. It is as essential as a knowledge of the temperature in febrile cases." The volume is avowedly a laboratory manual, and does not deal with the clinical interpretation of results. The technique described and advocated is essentially the same as that of Haldane and Douglas, of Cathcart and Orr, and of other recent English workers, with the modifications imposed by its application to persons at rest in bed. The only substantial change is the employment of a gasometer for measuring the volume of expired air, instead of the rougher and handier method of expressing the contents of a bag through a meter. Whether the gain in precision more than compensates the loss of simplicity must be decided by future experience. The authors describe each step of the routine clearly and fully, and provide tables which will be found very useful by the computer.

We think it well to conclude upon a note of warning. There is an old legal motto that he who seeks equity must do equity, which has an application here. Those who desire to ground clinical or physiological inferences upon quantitative measurements must give heed to the determination and limits of accuracy of their "normal" standards. Quite recently Harris and Benedict called attention to the weakness of some arithmetical arguments which have passed current in physiological circles. Perhaps the criticisms of the last-mentioned authors were in some particulars over-emphasized, but of the importance of the principle for which they contended we entertain no doubt. We do not believe that this method will be of value as a routine procedure until the discussion of the statistical significance of normal variations of basal metabolism initiated by Benedict and Harris has been carried a good deal further.

A TEXTBOOK OF DERMATOLOGY.

DR. MACLEOD'S *Diseases of the Skin*⁵ is one of the most important works on dermatology produced in this country in recent years. During the period that Dr. MacLeod has worked at his subject he has not neglected to study the writings of his colleagues and contemporaries; to this the present volume bears ample witness. References will be found therein to almost all the principal modern contributions to dermatology, although the author states that owing to the exigencies of space the bibliographies have been restricted. This textbook is, however, by no means a mere compilation, for although the author has done full justice to the work of others his own individuality and personal standpoint are visible from start to finish.

The book is singularly complete, for after a fairly exhaustive examination we have not detected any really important omission; another merit is that the amount of space allotted to the various subjects is very well adjusted to their relative degrees of importance. Dermatology is notoriously a subject overlaid with masses of detail, and to a large extent consists of the record of isolated facts which as yet do not admit of satisfactory classification. But while as a collector of facts and descriptions Dr. MacLeod need fear no comparison even with the Teuton, he has not allowed them to obscure his clarity of thought, and he has been able to maintain a unified conception of the whole field of his art. We would particularly commend to the student a perusal of the chapters comprising Part I, which includes the sections on general pathology, diagnosis, and treatment, both internal and local. They are full of sound principle and reasonable advice. Consideration of them will tend to steady the therapeutic head and prevent over-confidence in the claims of so-called "specifics" which from time to time become prominent in the dermato-

logical world. But, in classifying local medicaments into therapeutic groups, Dr. MacLeod should give more prominence to the protectives group, for these, which consist (as he states) of bland powders, thick ointments, and occlusive dressings, are the most important class of local therapeutic agents for application to the skin. The skin itself has for its chief function the protection of the underlying structures, and when it becomes inflamed it needs above all things protection itself in order to give the physiological rest which is the first rule in the treatment of inflamed organs. In the list of local medicaments in common use in dermatological practice there is, too, one curious omission, namely, zinc. Is it possible to practise the treatment of skin diseases at the present time without employing that metal either as an ointment, lotion, or powder?

No satisfactory classification of diseases of the skin has yet been devised. In this volume the etiological system is followed as far as possible, but when that has been pushed to its utmost limit there remain a host of conditions as to the causation of which nothing is known, and a place has to be found for them. Dr. MacLeod has grouped them to some extent regionally in chapters on affections of the hair, of the nails, of the lips, etc. He has also three very excellent chapters on neoplasms—one on benign neoplasms, another on malignant neoplasms, and a third on pseudo-neoplasms, under which term he groups the various forms of xanthoma, scleroderma, and calcareous deposits. These three chapters may be especially recommended to the attention of young surgeons and pathologists. They are well illustrated by drawings made by the author's pencil from his own sections. As one of the few British dermatologists who has made his mark in pathology he perhaps shines more particularly in this branch of the subject. Finally, there is a chapter devoted to tropical affections of the skin; this includes a miscellaneous collection of conditions which have in common simply the fact that they occur in warm climates. Many of these might well have been grouped more scientifically, for their etiology is well known; this is true, for example, of oriental sore, framboesia and others. A minor fault in the classification is the inclusion of Schamberg's disease under congenital abnormalities. Not many dermatologists will admit that this is a correct view of that singular condition.

Illustrations form an important part of any textbook of dermatology, and they have been lavishly provided in the present instance. Curiously enough, the monochrome photographs, on the whole, are of a far higher standard and give a much better idea of the conditions they depict than do the coloured plates, which have apparently been made from drawings, not from photographs. Too much stress is laid upon the necessity of having books on dermatology illustrated in colour; very often the coloured illustrations fail to give a better idea of the lesions described than ordinary photographs, and sometimes they are positively fallacious. To be really useful they must be made either from the very best photo-transparencies, preferably Lumiere autochromes, or from coloured drawings executed with a very great deal of labour by a highly skilled artist who has more time to give to the task than is usually available.

The literary style of the book is good; it is very readable, and the descriptions are often very happy. The author is to be congratulated on his work, which is a credit to British dermatology.

HYPNOTISM.

IN *An Introduction to the Study of Hypnotism, Experimental and Therapeutic*,⁶ by Dr. H. E. WINGFIELD, the practitioner who wishes to utilize this form of treatment will find a useful guide. The book is clearly written and essentially practical. The earlier chapters are devoted to definitions, the conception of the subconscious, the methods of inducing hypnosis, and the various phenomena of the hypnotic state. These more theoretical matters are followed by a long chapter in which the question of treatment by hypnotic suggestion is discussed. While the author has found hypnotism to be a valuable therapeutic agent in a number of nervous conditions, he is fully alive

⁴ *Laboratory Manual of the Technic of Basal Metabolic Rate Determinations*. By Walter M. Boothby, A.M., M.D., and Irene Sandiford, Ph.D. Philadelphia and London: W. B. Saunders Company, 1920. (Med. 8vo, pp. 117; 13 figures, 2s. net.)

⁵ *Diseases of the Skin*. A Textbook for Students and Practitioners. By J. M. H. MacLeod, M.D., F.R.C.P. London: H. K. Lewis and Co., Ltd., 1920. (Roy. 8vo, pp. 1327; 24 colour plates, 435 figures in black and white. £3 10s. net.)

⁶ *An Introduction to the Study of Hypnotism, Experimental and Therapeutic*. By H. E. Wingfield, M.A., M.D., B.Ch. Cantab. Second edition. London: Baillière, Tindall, and Cox, 1920. (Crown 8vo, pp. viii + 195. 7s. 6d. net.)

to its limitations, and writes with balance and restraint. Especially does he lay stress on the thesis that, though hypnotism may do much to begin a cure, the ultimate result must depend upon the personality factor. He shows that many nervous conditions are the product of an unhealthy manner of life, that the patient must himself strive to overcome his tendencies to indolence and self-indulgence, and that only by an endeavour to face the realities of life will he succeed in contributing his share to the welfare of the community.

PREVENTION OF COMMUNICABLE DISEASES.

MANY authors have written upon preventable diseases, but hardly one has dealt with the subject in such a thorough and comprehensive manner as Dr. FRANCIS M. MUNSON in his *Hygiene of Communicable Diseases*.⁷ It deals not only with such infectious diseases as measles and scarlet fever, but with many other ailments which are best described as communicable. Its scope is further shown by the author's statement that successful defence against infection is much more a personal affair than it was formerly considered, and that individuals can and must protect themselves. "If," he writes, "people practised reasonable cleanliness and put nothing in their mouths except what belonged there, most communicable diseases would be avoided." Cleanliness and disinfection are so nearly allied that we turn with interest to the chapter in which Dr. Munson deals with the latter. He describes the ordinary methods of disinfection, but considers that disinfection after a case of measles, diphtheria or scarlet fever is largely unnecessary, and that it is a waste of time, energy and money to attempt to disinfect the air of a sick-room while it is in occupation.

The chapter upon railway sanitation deals with the American Interstate Quarantine Regulations, which are so crowded with detailed instructions to railway employes and passengers that their very multiplicity seems calculated to defeat the object for which they were made. The all-embracing nature of these regulations may be gathered from the inclusion in them of sections dealing with the disinfection of shaving brushes as a safeguard against anthrax.

A very useful chapter is that concerned with the sanitary measures to be taken after great disasters such as floods, fires, and earthquakes. Very practical and well considered advice is given as to the improvization of water supplies, the emergency removal of refuse, and the promulgation of sanitary regulations in the event of the occurrence of such disasters. The author enumerates several measures which in his opinion are among those essential for the prevention of venereal diseases. These include education in matters of sexual hygiene, provision for accurate and early diagnosis and treatment, repression of prostitution by the police, restriction of the sale of alcoholic beverages, abandonment of the use of common towels in public places, and personal prophylaxis by those who expose themselves to the risk of infection. On the debatable question of compulsory notification of cases to the sanitary authority he is silent. Although obviously written for American readers the book will be of value to public health officers on this side of the Atlantic, if only because it will enable them to compare American administrative procedure with British, and not always to the advantage of the latter.

NOTES ON BOOKS.

THE fortieth volume of the *Transactions of the Ophthalmological Society of the United Kingdom*⁸ contains the proceedings of the Society during the session 1919-20, and those also of certain other bodies affiliated with it. In addition to individual papers the two discussions held by the Society are reported at length—the one on diabetes in relation to diseases of the eye, and the other on the prevention and treatment of ophthalmia neonatorum. It may be remembered that at the end of this discussion the Society adopted a resolution asking the Metropolitan

⁷ *Hygiene of Communicable Diseases*. A Handbook for Sanitarians, Medical Officers of the Army and Navy, and General Practitioners. By FRANCIS M. MUNSON, M.D. New York: Paul B. Hoeber, 1920. (Post 8vo, pp. 807; 36 figures, 5.50 dollars.)

⁸ *Transactions of the Ophthalmological Society*, Vol. xl. Session 1920; with list of officers, members, etc. London: J. and A. Churchill. (3s. net.)

Asylums Board, in view of the large number of cases of ophthalmia neonatorum congregated at St. Margaret's Hospital, to afford facilities at that hospital for teaching medical students, midwives, and district nurses the natural history and treatment of the disease. The report of the council of the Society calls attention to the increased cost of publishing and printing; in consequence the annual subscription has been increased to 3Is. 6d., and a reserve fund for publication, to which gifts are invited, has been established. Of the affiliated societies whose proceedings are embodied in the volume the first is the Oxford Ophthalmological Congress of 1920. The material published from this congress includes the Doynce memorial lecture on the nerve paths and centres concerned with sight, delivered by Mr. Richardson Cross of Bristol. The other societies whose proceedings are reported are the Midland, the North of England, the Irish, and the Egyptian Ophthalmological Societies. The last fifty-six pages of the volume are occupied by a general index to the *Transactions of the Ophthalmological Society for the ten years 1911-20*. The preparation of this index has, it is stated, led to some delay in the publication of the volume.

The eleventh edition of the well-known ambulance handbook, by Drs. WARWICK and TUNSTALL, entitled *First Aid to the Injured and Sick*,⁹ brings this little volume into its 150th thousand. The text and illustrations have been revised, and the new edition should maintain the popularity which this work has earned during the twenty years it has been before the public.

A small manual, *Serbo-Croatian Self-taught*,¹⁰ by Mr. JOHN O'BEIRNE, has now been included in the Marlborough Series. Serbo-Croatian is the language of the kingdoms of Serbia and Montenegro, of Bosnia and Herzegovina, of Dalmatia, Croatia, and Slavonia, and of certain parts of the south of Hungary; it is spoken by some nine millions of people. The main distinction between Serbian and Croatian lies in the different alphabets employed. The only other differences between the two are trifling details of dialect and pronunciation. Serbo-Croatian is thus one language with two alphabets. Both renderings are given in this little volume, but all the words are transcribed phonetically.

⁹ *First Aid to the Injured and Sick*. By R. J. WARWICK, B.A., M.B., and A. C. TUNSTALL, M.D., C.M., F.R.C.S. Eleventh edition, revised. Bristol: John Wright and Sons, Ltd.; London: Simpkin, Marshall, Hamilton, Kent and Co., Ltd. 1920. (Fcap. 8vo, pp. 260; 301 figures. Paper covers, 2s. 6d. net; leather, 5s. net.)

¹⁰ *Serbo-Croatian Self-taught, by the Natural Method*. By J. J. R. O'BEIRNE. Marlborough Self-taught Series. London: E. Marlborough and Co. 1921. (Cr. 8vo, pp. 111. Wrapper, 3s. net; cloth, 4s. net.)

APPLIANCES AND PREPARATIONS.

Two Instruments for Genito-urinary Surgery.

MR. JAMES MACMUNN (London) writes: The upper figure in the diagram below represents the combined massage and douching instrument for the prostate recommended by me in the correspondence columns of the *BRITISH MEDICAL JOURNAL* of January 22nd, 1921, page 142. The large massaging bulb—as large as the anal canal will admit with comfort—presses the secretions from the prostatic ducts, and at the same time aids the circulation of the haemorrhoidal plexus and the prostate, and higher up, the circulation of the vesico-prostatic plexus, which the finger cannot do. With this massage there is combined a strong stream of hot saline water, followed if desired by cold, upon the surface of the prostate. Thus, we have a means of alleviating congestion, resolving the inflamed tissue, and increasing muscular tone. The second figure represents a useful addition to prostatic massage, which must be used only by the surgeon. It is a long flat sound, as broad as the urethra will admit (I use three sizes), ending in a large bulb. The prostate is massaged against the convexity of the instrument. Hitherto Kollman's dilators were supposed to afford the best means of opening and emptying the ducts of the urethra, which is the chief consideration in the treatment of gleet, but, while this dilator can open follicles, it certainly cannot empty them, nor can suction. In my opinion, the only way to empty follicles is to massage them over flat sounds, preferably by means of a rubber roller. The instruments are made for me by the Holborn Instrument Company.

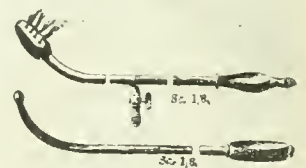

An Appendix Clamp.

MR. W. K. IRWIN, F.R.C.S.Ed. (London, W.), writes: In appendicectomy the usual routine is to apply two pairs of forceps and divide the appendix between them. By this procedure appendix contents are forced into the part between the

two pairs of forceps, and to prevent the spread of infection the surgeon is compelled to resort to the inevitable "drop of pure carbolic." To avoid this trouble I have devised the instrument depicted, which is as easy to apply as any pair of forceps. The clamping part of the instrument is wide enough (9 mm.) to allow the base of the appendix to be ligatured and divided in the part crushed, the peritoneal surfaces of which are brought

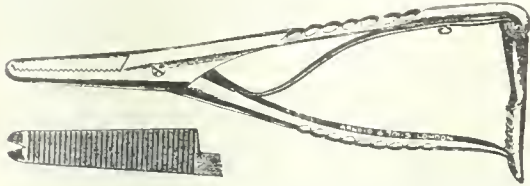

into apposition so that the appendix contents are forced away from the region of ligature and division. The crushing surfaces of the clamp bear transverse serrations, which fix the appendix transversely. To avoid any risk of injuring the peritoneum the serrations, while strong enough to effect their purpose, are very fine, and have their ends carefully rounded off. In my opinion clamps with smooth unserrated surfaces which act equally in all directions, unless they are narrow like Mr. Donald Armour's ingenious instrument, tend to produce a longitudinal rupture of the appendix. The ratchet catch and spring are similar to those used in various forms of needle holders, and are locked and unlocked with the greatest ease. The clamp has been made in accordance with my suggestions by Messrs. Arnold and Sons.

Catheter Holder for Intrauterine Treatment of Gonorrhoea.

Dr. REMINGTON HOBBS, Medical Superintendent, Kensington Infirmary, writes: Since my article on the treatment of gonorrhoea in women appeared in the *Practitioner* last January I have had many more cases under treatment. In order to facilitate the introduction of the catheter into the fundus uteri I have devised a catheter holder, as illustrated. It is a light,



handy instrument for introducing a small terminal-eyed catheter into the uterus. It has the advantage that, owing to its size and to the bend in the shank, the line of vision of the catheter is not obscured. When the catheter has been inserted the lumen of the tube is not obliterated, so that the fluid can be syringed through whilst the tube is retained *in situ* by the holder. The instrument has been made for me by J. H. Montague, 69, New Bond Street, W.1.

INTERNATIONAL RED CROSS CONFERENCE.

THE tenth International Red Cross Conference at Geneva was closed on April 7th; it accomplished a great deal of work, but the practical results will only be seen after the various national societies have had time to consider and act upon the recommendations made.

The conference unanimously adopted resolutions inviting national governments to make additions to the Hague Convention absolutely forbidding the use of poison gases, whether as drift gases or in projectiles, and limiting war in the air to strictly military objects, so that the civil population may be as far as possible protected from this new weapon, and useless destruction avoided. A resolution, proposed by Mr. Frank Hastings, asking the governments to take steps to add to the International Convention rules governing the protection of aeroplane ambulances and air ships used for the carriage of sick or wounded, was adopted.

A recommendation, asking that a clause should be added to the Hague Convention forbidding the bombardment of undefended places, led to a good deal of discussion; it was finally adopted, as was also the suggestion from the Swedish and Danish Red Cross Societies that the rules should permit supplies to pass through a blockade to sick persons, old people, and children, although the difficulties in the way of carrying out this recommendation were recognized.

Among the resolutions adopted with regard to Red Cross work in peace was one to the effect that Red Cross societies should organize help for persons crippled in civil life, and that such help should include the establishment of special hospitals providing prosthetic apparatus and instruction in

suitable trades. A resolution proposed by Sir John Lynn-Thomas, who had read a paper on the subject describing what had been done at the Prince of Wales's Hospital, Cardiff, for Wales, was approved by the appropriate committee and adopted at a meeting of the full conference. It set out that Red Cross societies should deal with the pressing problem of civilians who have lost a limb, in order to extend to them the benefits of the organized treatment which was for the first time established during the war to meet the needs of crippled soldiers and sailors.

A committee was appointed to consider the part the Red Cross should take in civil war; it recommended that the Red Cross Society of the country in which civil war prevailed should not be authorized to ask directly for help from the Red Cross societies of other countries, but only through the International Red Cross Committee. Discussion arose on several occasions during the course of the conference with regard to the present position in Russia. The International Red Cross Committee had been prepared to recognize the Russian Soviet Red Cross Society, but the president of that society made difficulties in attending and did not attend. Representatives of the old Russian Red Cross were present. Eventually resolutions were adopted by the conference calling the attention of the people of all countries to the fact that a state of civil war does not justify the violation of ordinary human rights, and protesting against the system of taking political hostages from among the families of accused persons, as also against the cruelties inflicted upon prisoners and upon persons interned during the civil war in Russia. The committee appointed to deal with matters affecting prisoners of war found the number and complexity of the questions raised too great for its resources; and M. Dinichert, representative of the Swiss Government, informed the conference that he had reason to hope that the Swiss Federal Government would take steps to bring about a diplomatic conference on the subject.

Before separating, the conference expressed the hope that the International Red Cross Committee would receive sufficient pecuniary support from the various countries, and that in future international congresses would be held at shorter intervals.

The Red Cross societies of the following countries were represented at the conference: America, Argentina, Australia, Austria, Brazil, Bulgaria, Canada, Chili, China, Denmark, Esthonia, Great Britain, Greece, Germany, Hungary, Holland, India (British), India (Netherlands), Italy, Japan, Latvia, Luxembourg, Mexico, New Zealand, Norway, Poland, Portugal, Rumania, Serbia, Siam, Sweden, South Africa, Spain, Sweden, Switzerland, Czecho-Slovakia, Venezuela, Turkey. An asterisk indicates that the Government of the country was also represented. In addition the following Governments were represented: Columbia, Ecuador, Haiti, Peru, Persia, Uruguay. The Papal Nuncio was present in a consultative capacity, as were also representatives of the Red Cross Societies of Rumania, Lithuania, and Ukraine, the International Labour Bureau, the American Relief Administration, and the Save the Children Fund.

As already stated, an agreement defining their respective spheres of work has been reached between the International Red Cross Committee and the League of Red Cross Societies. The latter was represented at the conference by the Director-General (Sir David Henderson), the Medical Director-General (Professor C. E. A. Winslow), and other officers.

A BRITISH home for necessitous Austrian children is being established on the estate of Klessheim, granted at what is described as a nominal rent by the provincial government of Salzburg. The home contains thirty children, but could accommodate five hundred were equipment and funds available. There is a British director, with a staff of trained nurses and other helpers. The parents are asked to contribute to the cost, and the American relief administration gives one meal a day. In this connexion it may be noticed that the American Relief Fund has sent Professor Pirquet 10,000 dollars to purchase food for the families of the lecturers in medicine at Vienna. The sum has been divided among two hundred families, who have consented to adopt Professor Pirquet's dietetic method described in our columns of October 30th, 1920.

British Medical Journal.

SATURDAY, APRIL 16TH, 1921.

THE EPIDEMIOLOGY OF TUBERCULOSIS.

As we have frequently pointed out, opinion respecting the epidemiology of tuberculous diseases has changed enormously within the last decade; no better illustration could be afforded than by the recently published work of Colonel Bushnell, a distinguished officer in the United States Army Medical Corps.¹ Though he modestly disclaims any authority conferred by the prosecution of original research, his essay is not the less valuable as a clearly written and even weighty contribution to the literature.

His main argument will not be novel to readers of Professor Calmette's papers and was restated with additional evidence by Colonel Lyle Cummins a few months ago. But Colonel Bushnell has covered a wider literary field, and his familiarity with American military and other official reports enables him to furnish information which is not available to most English readers. Expressed in a few sentences, his argument runs as follows: There is a fundamental distinction between the epidemiological behaviour of tuberculosis in races recently exposed to infection and amongst populations wherein the disease has prevailed for generations. Amongst the former alone do epidemics comparable to those of zymotics occur, and amongst them variations of climatic or hygienic conditions are factors of but minor importance. On the other hand, amongst acclimatized races the mortality of tuberculosis varies with the hygienic conditions and therefore, to a large extent, with social status. Not to speak of examples, such as that of the Kalmucks, which have frequently been quoted before, the contrast between the experience of the American negro and the American Indian is a striking illustration of the author's argument.

Colonel Bushnell is led to conclude that any attempt to eliminate sources of infection in settled countries would, if successful, be positively injurious. "Supposing," he writes, "that with extraordinary energy and sagacity we banish all tuberculosis from our town and rear an absolutely uninfected group of children. Having passed a childhood under the irksome restrictions that would be necessary, the time must come when they shall be permitted to enter the outside world, for the fear of disease cannot remain the paramount consideration during life. As soon as, now adults or adolescents, they leave the sheltering confines of their native town they will be exposed to the dangers of primary tuberculous infection, and that at an age when the world beckons most invitingly, and when prudence is least developed! In fact, they would be in a hardly less dangerous situation than the tropical native when he first enters a civilized community. Prophylaxis has simply resulted in exchanging the danger of a chronic and usually relatively benign infection for the danger of an acutely fatal infection." Colonel Bushnell thinks, in fact, that we should strive to substitute "an

artificial premeditated infection for the present infection by chance," but he perceives that we have not as yet nearly sufficient knowledge to justify any such proceeding. We need, he thinks, to study the later history of those who were positive to the von Pirquet reaction, and compare it with the fate of those not responsive to the test in successive years of age. He would have a careful record kept by name of all the children that have been tested, and the history—particularly, of course, the tuberculosis history—of each child should be followed at least up to the 30th year. "It being ascertained," he says, "that a given child has recently become infected, proper steps can be taken to ensure the best possible care for it, to the end that the infection may remain latent. There can be no doubt that the first half-year after infection is a critical time for the child. Proper attention at this time would do more to lower the morbidity and mortality from tuberculosis than anything except preventing the infant from coming into contact with the consumptive. The work would be of great value if limited to the acquisition of data to be utilized only for the prophylactic care of recently infected children. We should, however, aspire to more. What an enormous mass of valuable data is lost because acquired a little at a time by many individuals, and never collated!"

Colonel Bushnell's opinions respecting the dangers incurred and the precautions to be taken when uncivilized races are brought into contact with the civilized, especially his strictures upon the impolicy of introducing consumptives from an old country into the midst of a virgin race, will command universal assent, but his observations upon the present and future of antituberculosis measures in an industrial population will not be so generally approved. It will, for instance, be argued that the danger of massive infections in adult life has not been sufficiently considered. In England and Wales (1910-12) the standardized mortality from tuberculosis of shoemakers was 456 per cent. of that of clergy; printers and bookbinders were nearly as bad; bricklayers had only 273 per cent. and coal-miners only 163 per cent. of the best attainable rate. It is not possible to argue that the domestic standard of life amongst bricklayers and coal-miners is far superior to that of printers and shoemakers, or that in childhood prophylaxis has been more efficiently carried out by "nature" for the children who are to become bricklayers than for those who will develop into printers. Hence we must suppose that either (a) physical occupational selection, (b) the hygienic conditions of labour, in Dr. Leonard Hill's sense, or (c) opportunities for massive infection, or all three factors combined, are enormously important factors of etiology.

The ultimate solution of the tuberculosis problem is not likely to be found in an expedient theoretically so simple as the deliberate immunization of the whole race during childhood.

Colonel Bushnell considers that one of the most dangerous doctrines relating to prophylaxis is that good health prevents tuberculous infection. He admits that good health will prevent tuberculous infection from becoming tuberculous disease, but denies that good health has anything to do with the reception of the tubercle bacillus into the body. This is, we think, literally true, and an important warning when the contact of virgin races with the civilized is in question. But it must not be misinterpreted into a suggestion that within a civilized community any measures whatever can be of higher importance than those destined to secure a high standard of physical and mental efficiency in the popular sense.

¹ *A Study in the Epidemiology of Tuberculosis, with Especial Reference to the Tuberculosis of the Tropics and of the Negro Race.* By George F. Bushnell, I.H.D., M.D. London: Bale, Sons and Danielsson, Ltd. 1920. (Pp. 221. 20s. net.)

As we said at the outset, Colonel Bushnell's work expounds a philosophy of tuberculosis very different from that which flourished but a few years since; it is, we think, a truer philosophy, but there is still need of a wider basis and a risk lest the new doctrine should tend to a particularism, a narrowness, which was the fate of its predecessor.

THE PHYSIOLOGY OF PAIN.

UNTIL comparatively recent times the problem of pain has been a subject of philosophic speculation rather than of physiological study. The philosopher has usually approached the question under the conviction that pain must necessarily and, however indirectly, have value and meaning for mankind. A recent review¹ observes that philosophical methods and conclusions are unsatisfying to the biologist, who is met at the outset by the fact that there is an enormous discrepancy between the amount of experienced pain in the world and any observed physical, mental, or moral benefit that ensues to the sufferers. It has often been assumed that, within limits, sensitiveness and liability to pain constitute conditions tending to favour survival. These assumptions cannot be unreservedly accepted. It is not correct, for instance, to regard pain as invariably related, as to its origin and continuance, with some definite underlying abnormality of which it is a mere or less precise expression and measure.

Certain peculiarities in the status of pain are not difficult to detect, and they may be indicated in three broadly defined groups. The first of these peculiarities is the frequency of pain. It is the commonest disturbance of well-being to which man is subject. Even the healthiest of us will find that, quite apart from injury, scarcely a day passes without some transient twinge or stab or ache that easily lapses from a healthy memory because it is unaccompanied by any other evidence of abnormality.

The second is the relation of pain to its bodily cause. Pain is of all symptoms the one most likely to be persistent and inveterate. The longer it persists the more difficult it is to relieve, though the originating lesion has ceased to exist. It seems almost as if when pain has been present for a long time it became as it were ingrained in the very substance of the nervous system, and rendered truly ineradicable.

The third peculiarity concerns its functional value. Within the comparatively narrow limits of recoverable injury pain furnishes the patient with guidance whereby life or activity may be preserved. We see proof of this in the damage that may ensue when the sensibility to pain is lost, in such diseases as tabes and syringomyelia. But it soon becomes obvious that a sharp distinction must be drawn between pain in relation to disease and pain in relation to injury. In the majority of diseases it is no more than an arbitrary and superadded affliction. Certain diseases consist, as it were, entirely of pain: in trigeminal neuralgia and the pain that sometimes follows amputation the one symptom constitutes the whole disease. Such cases exemplify the very acme of the functional uselessness of pain. A superficial examination of the symptom as met with in practical medicine furnishes a fair body of evidence that it occupies a remarkable, an even unique position.

The study of pain in the normally innervated skin has yielded certain definite and well established facts which justify the general statements that the

peripheral pain mechanism is excitable by a number of different stimuli which have no single physical character in common. While the stimulus required is relatively intense, the consequent reaction is relatively excessive. The most remarkable feature, however, is anatomical: the peripheral pain end-organ differs from all other end-organs in being a mere tree and naked terminal arborization. A specialized end-organ is to be regarded as at the same time increasing accessibility to one specific stimulus and diminishing it to all others. Of the other specific sensory spots in the skin each is accessible to one stimulus alone. The touch spot responds to movement, the heat spot to transference of heat to the skin, the cold spot to transference of heat from the skin. But the pain spot is accessible to stimulation by all of these, with the reservation that the mechanical stimulus that would excite a touch or thermal spot has to be increased in intensity in order to stimulate a pain spot. That is to say, the threshold of the pain spots is relatively high, and when the threshold is reached the sensation "pain" seems suddenly to burst upon the sensorium with a veritable explosion of reactive energy. This explosive quality of the sensation of pain constitutes one of the chief features distinguishing it from other sensations, which in the main possess mere "recognition" qualities.

After simple division of a nerve, as in amputation, an outgrowth of axis-cylinders occurs from the central end into the surrounding tissues. The nervous elements seem to seek to invade, the connective tissue elements to restrict the invasion, and each seems to be excited to activity by the other. The invading axis-cylinders fail to obtain the requisite insulation which appears essential to all peripheral nerves, they fail to find a termination in appropriate end-organs, and remain to all intents free and naked arborizations of neural tissue in somatic tissue, and come to resemble in that respect "pain" end-organs. Thus they become exposed to constant subliminal excitation, and this fact perhaps explains that intensification of sensibility met with in recovering areas which makes all forms of stimuli result in sensations akin to pain. All other end-organs than those of pain have their terminal fibrils shut in by a well-marked encapsulating formation. This completeness of insulation may be a means of damping down the general excitability of such nerves so that the sensations they originate shall be without urgency and explosiveness, and permit of that quiet sensory atmosphere in which alone deliberation and discrimination are possible.

The review concludes with an attempt to trace out the way in which the evolution of common sensation has proceeded. The germ of a nervous system is a group of cells capable of irritating and being irritated by the other cells of the body. The essential hostility of neural and non neural tissues gives us, perhaps, a hint of the physiological significance of the ectodermal origin of the nervous system, and of its being formed at the surface and then sinking *cell by cell* into the substance of the embryo. The opportunities for contact between the two tissues require limiting and regulating. As we should begin in the animal scale we find an extended series of increases in the centralization and insulation of the nervous system, centralization rendering the insulation easier until we see in the human nervous system how very elaborate and complete the mechanisms securing this condition have become.

In animals with a diffuse nervous system response to stimulation seems to be for the most part immediate and urgent, so that what sensation there is in such animals is all of the quality which survives in

¹ *Medical Science, Abstracts and Reviews*, 1921, iv, 43.

man only as pain. Delay between stimulus and response is possible when improved insulation has damped down the urgency of incoming sensation; as soon as delay is possible deliberation and discrimination appear. Sensibility to pain, it is suggested, is the survival of the primordial mode of sensation. Its urgency and tendency to evoke immediate motor response is the reproduction of the normal experience of the lower invertebrates. From it the discriminative forms of sensibility have been differentiated by the progressive increase of insulation. Regeneration of a nerve by exposing a greatly increased number of nerve fibres to somatic contact and irritation throws back all forms of sensibility more or less into the primitive type and provides an explanation of the characteristically variable phenomena of recovery after suture. If we view pain as an exaggerated response by a physiologically irritated nerve, it is possible to get some conception why pain is the commonest of symptoms, and why it is apt to become inveterate. Pain is, as it were, physiologically just not present in us all, and what appears to be a very slight disturbance pathologically may prove an effective and incurable excitant of it.

THE EVEREST EXPEDITION.

For the past few months preparations have been in active progress for the expedition, organized jointly by the Royal Geographical Society and the Alpine Club, to explore Mount Everest, the highest peak in the world. The preliminary survey and the subsequent ascent have been made possible by the permission of the Tibetan Government for the expedition to enter Tibet. Hitherto no mountaineer has reached within about sixty miles of Mount Everest, and the northern approaches to this and the neighbouring Himalayan peaks have never been surveyed; the advance through Tibet will therefore break wholly new ground. Apart from the difficulties of travel in remote and unexplored mountainous districts, the two chief problems appear to be the maintenance of supplies and the preservation of health and vigour at great altitudes. Recent work in physiology suggests that the key to success is an adequate supply of oxygen and of foods rich in vitamins, but the transport of oxygen in bulk over mountainous passes would be a formidable undertaking. It is estimated that on the summit of Mount Everest the rarefied air contains only one-third of the usual amount of oxygen. As the President of the Alpine Club, Professor J. N. Collie, F.R.S., has pointed out, in those accustomed to high altitudes this suffices to support life, but the human engine obviously cannot do much work with so limited a supply of oxygen. The body, however, makes efforts to adapt itself to high altitudes, chiefly by a rapid increase in the number of red blood corpuscles. People living on the Pamirs—the extensive plateau known as “The Roof of the World,” from which diverge the principal mountain chains of Asia—have an average count of over 8 million red cells per cubic millimetre. Trained mountaineers have proved their ability to live and at the same time do a certain amount of work at an altitude of nearly 25,000 feet, and Professor Collie believes that the extra 4,000 feet necessary to climb Everest should not prove entirely prohibitive. The main objects of the survey party will be to reconnoitre the northern slopes of Mount Everest, with a view to finding a possible way up the peak itself, and to establish an advanced base for the party that later essays the final ascent. The leader of the present expedition is Lieut.-Colonel Howard Bury. The mountaineering party consists of Mr. H. Raeburn, with Messrs. G. Mallory and Bullock, members of the Alpine Club. The medical officer and naturalist is Dr. A. F. R. Wollaston; the chemist is Dr. A. M. Kellas, lecturer on chemistry in the Middlesex

Hospital Medical School; and two members of the Indian Survey—Major Morshead and Captain Wheeler—are attached to the expedition. The survey party propose to leave Darjeeling on May 14th, travelling towards Tibet through the Chumbi Valley.

EPIDEMIC HICCOUGH AND ENCEPHALITIS LETHARGICA.

A CONTRIBUTION of considerable value in regard to the association of epidemic hiccough with encephalitis lethargica was made by Dr. William Boyd, professor of pathology in the university of Manitoba, Winnipeg, in two papers published last year.¹ Encephalitis lethargica reached Winnipeg in the last week of October, 1919, and gave rise to a somewhat extensive epidemic. Of the 75 cases with which Dr. Boyd had personal acquaintance 29 died, and complete necropsies were made by him in 19 cases; in two other fatal cases, in which a complete examination could not be made, the kidney was removed for pathological examination. Professor Boyd gives a careful and well illustrated summary of the history, symptomatology, and pathology of the disease, and comes to the conclusion that the relation of encephalitis to influenza is more apparent than real, as twelve months separated the outbreak of the former from the latter, and most of the patients who suffered from encephalitis had never had influenza; similarly, his opinion is that the condition is quite distinct from poliomyelitis. There was a most remarkable epidemic of persistent hiccough in Winnipeg and the neighbouring towns in the early part of November, 1919—at a time, Dr. Boyd states, when it had not been reported from any other cities, and a few days after the first cases of encephalitis had appeared in the city. A very large number of cases occurred. The patients included several doctors, one of whom kept hiccoughing continuously at intervals of about a minute for five days; the usual duration of an attack was from twenty-four to forty-eight hours. The condition yielded readily to a single injection of morphine. If the two epidemics bore no relation to each other, Dr. Boyd suggests that the coincidence is at any rate remarkable. The myoclonic contractions of the abdominal muscles observed in lethargic encephalitis and the contraction of the diaphragm in hiccough were very much alike. Could it be, he asks, that the virus of the disease might spare the brain in mild cases but irritate the cervical origin of the phrenic nerve?

RESEARCH DEFENCE.

THE Research Defence Society has done a great amount of useful work during the thirteen years of its existence. It is something of a reproach to the intelligence of the nation that it should have to exist at all, but unhappily the opponents of experimental medicine—and in that we would include physiology as well as pathology—are among the most active of those who seek to obstruct the advance of science. It is a national society of men and women united to promote national health and efficiency, to bring about a better understanding of the value of medical and surgical studies, and to expose the false statements made against them. Before the war it had about 5,000 members and associates; it has not so many now, and this is a pity, for all of us enjoy the benefits which result from the studies the Society exists to defend. It was founded in 1908. Among those present at the foundation meeting was the late Lord Moulton, though, as one of His Majesty's judges, he did not think it proper to become a member. In the last number (April) of a little quarterly journal the Society issues, we are reminded of the very valuable evidence Lord Moulton gave before the Royal Commission in July, 1907. In the course of his evidence, copies of which the Society can, we understand, still supply, Lord Moulton said: “The advance of science

¹The Canadian Medical Association Journal (February, 1920) and *Annals of Medicine* (Vol. 1, No. 2, July, 1920).

takes the workers in science more and more beyond the ken of the ordinary public, and their work grows to be a little understood, and much misunderstood; and I have felt that the need would come for interpreters between those who are carrying on scientific research and the public in order to explain and justify their work." It is for this reason that the Society's motto is *Interpres Interpretum*. Men and women of science are interpreters of Nature, and therefore the society which popularizes their work is an interpreter of interpreters. The Society will arrange addresses and lantern lectures and is prepared to supply literature to applicants, but it wants more members. The subscription, which is only 6s. a year, to include the Society's publication, may be sent to the Secretary at 11, Chandos Street, London, W.1. The president of the Society is Lord Lamington, the chairman Viscount Knutsford, the vice-chairman Mr. Stephen Paget, F.R.C.S., long its honorary secretary; its present honorary secretary is Lady Horsley, its parliamentary honorary secretary Captain Walter E. Elliot, M.P., and its honorary treasurer Sir David Ferrier, F.R.S. The last copy of the Society's quarterly, *The Fight Against Disease*,¹ contains a series of notes on various subjects, including the recent work of Calmette on tuberculosis, described in the BRITISH MEDICAL JOURNAL of December 11th, 1920. The very smallness of the subscription stands in the Society's way; it seems too much trouble to get a postal order for 6s., but we hope many of our readers will take that trouble nevertheless.

THE DISCOVERER OF BRIGHT'S DISEASE.

The first volume of the new series of the *Guy's Hospital Reports*, edited by Dr. A. F. Hurst, with assistance in the various special departments, has somewhat altered its outward aspect, and is now to appear quarterly; but its contents are as attractive as ever, and among them the first is appropriately that on "Richard Bright and the discovery of the disease bearing his name," by Sir William Hale-White,² who dutifully speaks of his hero as certainly among the first five or six geniuses in our profession. Historical memoirs and obituaries rightly form part of the subject matter of hospital reports, and in the past the *Guy's Reports* have been noticeable in this respect; it is therefore satisfactory to learn that Sir William Hale-White will supplement his present interesting article by one on "Bright's contributions to medicine apart from kidney disease," and that Dr. John Fawcett will write on "Addison and Addison's anaemia." The life-history and pathological activities of Thomas Hodgkin should also find a similar biographer, for he did much, and yet is chiefly remembered on account of the late Sir Samuel Wilks's self-denying loyalty in calling what is now more commonly known as lymphadenoma, Hodgkin's disease. In addition to a marvellous ability for making accurate observations, Bright had the much rarer gift of correlating and synthesizing data; he was a pioneer in cerebral localization, and one of the earliest describers in this country of acute yellow atrophy of the liver, of malarial pigmentation of the brain, of pulmonary collapse in whooping-cough, and the mitral murmur in chorea. But the causal relation of kidney disease to albuminuria and dropsy will always stand out along with Laënnec's work on thoracic disease (on which Sir William Hale-White is also to contribute a memoir) as the outstanding discoveries in medicine in the early part of last century; Bright's conclusions were solidly based on extensive observations at Guy's Hospital, and were published in 1827, 1833, and 1836, the last paper being entitled "A tabular view of the morbid appearances in one hundred cases of albuminous

urine." Sir William Hale-White describes this series of papers as one of the most wonderful in medical literature, and points out that except for retinal changes and blood pressure estimations every ordinary clinical manifestation is mentioned; Bright did indeed refer to the occasional occurrence of impaired vision and a hard pulse. So careful and complete were his observations that comparatively little has been added since he proved that the renal change is the primary factor. It is, of course, true that the association of albuminuria with general dropsy had been previously established in 1806 by William Charles Wells, the author of the famous "Essay on Dew," who, while giving the credit for the detection of albuminuria to Cruickshank in 1798, believed that all the abdominal organs, including the kidneys, were inflamed. Dr. John Blackall of Exeter, in his "Observations on the Nature and Cure of Dropsies," elaborated Wells's observations on albuminuria, and appears to have suspected that the kidneys were affected; but though these physicians may have prepared the way for Bright's great discovery they in no way anticipated it.

LIGATIONS OF THE LEFT SUBCLAVIAN ARTERY.

The twenty-first volume of the *Johns Hopkins Hospital Reports* (fasciculus 1) is entirely devoted to an exhaustive and interesting analysis by Professor Halsted of ligatures of the first portion of the left subclavian artery. The total number of cases in which this difficult operation has been performed are few, only 21 in all being recorded in the literature. This is partly due to the fact that the older surgeons forswore the operation, declaring that it was "bad in principle" and "most unfortunate in practice." The first part of the subclavian is, on the left side, very deeply placed, and in the presence of an aneurysmal sac of any size the field of operation is so cramped that the surgeon needs an eagle's eye, a lion's heart, and a lady's hand, as Thomas Fuller said, to carry the undertaking to a successful conclusion. Professor Halsted's monograph opens with a delightful and characteristic quotation from Osler tracing the history of the surgery of aneurysm, and proceeds to the description of successful ligature for a huge subclavian aneurysm. How large this was, and how formidable was the task of tying the vessel, may be readily appreciated from some excellent photographs of the patient. Halsted resected the left sterno-clavicular joint and the left two-thirds of the manubrium. Later he had to sacrifice the first costal cartilage and the adjacent part of the sternum. The arch of the aorta and its descending part were then clearly seen and the left auricle of the heart could be palpated with the finger. At length the left subclavian artery was identified lying close to the vertebral column. Two pieces of linen tape were threaded round the vessel and tied with force sufficient to close completely the lumen without crushing the vessel wall. Recovery was uneventful, and the aneurysmal sac shrank greatly. Two years later it was seen to be again increasing in size. Professor Halsted then excised the whole sac after resecting the middle of the clavicle. The success of this case is a just and fitting tribute to the distinguished operator, for he it was who, in 1892, performed the first successful ligature of the first part of the left subclavian. The paper is in many ways full of interest and of scholarship. It contains an instructive discussion of the value of simultaneous ligature of the vein when dealing with the vessels at the root of a limb and in the popliteal space. Professor Halsted pays homage to Sir George Makins on this question, and gives a full translation of the classic case of Von Opperl and Korotkov, which illuminates the subject in an inimitable manner. It would appear that the only British surgeons who have tied the first part of the left subclavian artery are Stonham, Sir William Banks, C. G. Browne, Newbolt, Sinclair White, and Sir Charles Ballance. It must be admitted that this is a very

¹ Macmillan. Price 6s.

² *Guy's Hospital Reports, 1921*, vol. lxxi (vol. i, fourth series), No. 1, pp. 1-20. Issued quarterly. London: Henry Frowde, Oxford University Press. Subscription, 2 guineas, post free for volume of four numbers; single number, 12s. 6d.

fair proportion for one country out of 21 recorded cases, but it is possible that others may have performed the operation without recording the fact in print.

THE OPTOPHONE.

DR. ARCHIBALD BARR, Emeritus Professor of Engineering in the University of Glasgow, on April 6th demonstrated before the Royal Society of Arts the improved optophone, the instrument invented by Dr. Fournier d'Albe for enabling the blind to read ordinary print. This instrument was first shown in this country by the inventor in 1912, before the Optical Convention, but at that time the stage of its development was such that a blind person could by its use only distinguish bright lights. A year later, when it was exhibited to the British Association in Birmingham, it had been improved so that printed letters could be recognized. The war retarded further development, but since the war Dr. Barr, having the resources of the engineering firm of Messrs. Barr and Son behind him, has, with the co-operation of Dr. Fournier d'Albe, so perfected the mechanism of the invention that with its aid ordinary letter-press can be read by a blind person after comparatively little practice. The instrument depends for its action on the fact that the conductivity of electricity by metallic selenium is increased by light. Above an electric filament lamp revolves a disc with five rings of perforations around its circumference. The light flashing through the perforations in the disc is led by a series of lenses to two selenium detectors which are interposed in a circuit with a battery and a telephone, and the flashes of light are transformed by the selenium detectors into sounds in the telephone. When the amount of light is modified by the interposition of any object, the sound in the telephone is modified accordingly, and this happens when the figure of a black letter of the alphabet, moved across a slot, is reflected into the line of the light from the lamp. The notes which are given out differ with each letter, so that letters, and eventually words, can be recognized by their distinctive notes. Even the audience at Dr. Barr's demonstration was able, under his tuition, to recognize certain large capital letters in a few moments. A blind lady who had had, it was stated, only some thirty hours' practice, was able before the audience to take up a book, place it in position on the instrument, and after a little difficulty in finding where the print commenced, read out several lines quickly without any mistake. Such languages as Hebrew, Arabic, and Chinese, with their distinctive calligraphy, would be even easier to read in this way than Roman letters, and Dr. Fournier d'Albe, who was present at the demonstration, claimed that with its aid the literature of the whole world is opened to the blind.

HOSPITAL ALMONERS.

The report of the Hospital Almoners' Council for 1920 shows the increasing value of the work undertaken by this organization. It is important that almoners should be carefully trained and should have special qualifications for the post, and it is to these matters that the Council mainly devotes its attention. The view is now generally held that an almoner's duty does not merely consist in checking abuse of the out-patient department of hospitals. This officer, who is usually a woman, should acquire a knowledge of the patient's home conditions for the use of the hospital staff, and should co-operate with other charitable agencies in order to aid in carrying out the prescribed treatment in the most thorough manner. She should have a complete knowledge of the municipal and State activities which may have an influence upon the health and social conditions of the patient, and should organize the "after-care" of patients on discharge from hospital. If an almoner is to carry out such important work properly a thorough training, both general and technical, is necessary, and this training the Council is

providing. It extends over two years; part of this time is spent in general instruction in economic social theory at the University of London and in practical work with the Charity Organization Society. The remainder of the period is spent under the direction of an almoner at a hospital training centre in gaining a knowledge of an almoner's duties not only in the hospital, but in health visiting, infant welfare centres, rescue homes, and tuberculosis clinics. Certificates are granted by the Council to almoners who have gone through the recognized training; the offices of the Council are at Denison House, 296, Vauxhall Bridge Road, S.W.

CALCUTTA SCHOOL OF TROPICAL MEDICINE.

AN appeal to the Government of Bengal for an annual grant has been made by the Calcutta School of Tropical Medicine and Hygiene and the Carmichael Hospital for Asiatic Diseases. The financial statement issued with the note shows that down to the end of February Rs.20,77,904 had been subscribed, and that out of this the buildings and equipment had been provided, and an endowment fund of Rs.3,55,000 created. The estimate of recurring annual expenditure amounts to Rs.5,20,228, leaving a balance of Rs.3,92,000, which the Government of Bengal is now asked to provide. The appeal points out that the scheme has two sides, research and teaching—both essential for fighting disease—and that it is the teaching side the Government of Bengal is especially invited to support. The buildings, erected and equipped with the funds raised by Sir Leonard Rogers, provide not only for research work, which is already in part endowed, but also for post-graduate teaching of tropical medicine and hygiene.

PHOTOGRAPHS OF CRETINS.

WHEN the British Medical Association met at Carlisle in 1896, Dr. W. Rushton Parker of Kendal exhibited photographs of over fifty cases of sporadic cretinism which he had succeeded in collecting from many sources. This collection of photographs—one of the largest yet made—has been presented by Dr. Parker to the Royal College of Surgeons of England, where it may be seen and studied by all interested in cretinism.

THE Earl of Onslow, formerly Parliamentary Secretary to the Ministry of Agriculture, has been appointed Parliamentary Secretary to the Ministry of Health, in succession to Viscount Astor, whose resignation on the ground of ill health was announced a month or two ago. Sir Alfred Mond, Minister of Health, has appointed Sir H. Kingsley Wood, M.P., to be his parliamentary private secretary.

WE regret to announce the death, on April 12th, of Dr. Henry Barnes, O.B.E., of Carlisle, who was President of the British Medical Association in 1896-97. We hope to publish a memoir in an early issue.

Medical Notes in Parliament.

[FROM OUR PARLIAMENTARY CORRESPONDENT.]

Public Health and Local Rating.

WITH the revival of the rights of private members to bring up subjects on a limited number of evenings, Colonel Bowles, on April 6th, moved for the appointment of a Select Committee to inquire into the incidence of local rating by public authorities. He argued that these bodies had grievances in the burdens put upon them. He quoted the recommendation of the Royal Commission of which Lord Balfour of Burleigh was chairman, in 1904, that asylums for pauper lunatics should be made a national service, and pointed out that since then expenses for National Insurance, for tuberculosis sanatoriums, provision for medical inspection of schools, asylum officers' super-annuation, and the working of the Mental Deficiency Act and of the Venereal Diseases Act had severally, in part or wholly, been placed on local rates.

Sir Arthur Warren, seconding the motion, reminded the House that under the Tuberculosis Bill now before Parliament there was an estimate that additional services would cost £40,000, and of this half was to be provided from the rates.

Sir Alfred Mond, the new Minister of Health, in the course of his reply, recalled that the cost of the fresh work which had been imposed upon local authorities by health developments—in regard to tuberculosis, venereal disease, maternity and child welfare—did not amount to more than a 2½d. rate through the country. He did not wish to indicate that he felt that new services should be lightly thrust upon local authorities at the present time. On the contrary, he took this first opportunity of stating to the House that it was his firm intention to endeavour to avoid all unnecessary expenditure in the very difficult financial condition in which the country was placed. While, however, it was important not to incur unnecessary new expenditure, it was, he said, even more important to see that full value was got for old expenditure. The fact that money was being spent on a service was by no means necessarily evidence that the best result was being obtained. Large expenditure did not necessarily show great zeal; often better results could be got by careful administration. He intended to devote his attention strictly to this side of the work. In this connexion he referred to a request made to him to introduce fresh legislation for the superannuation of Government officials, which would have put an increased burden on the rates.

Major Prescott, interrupting, asked whether the Minister was not aware that the recommendations of the Departmental Committee would not involve any charge on the rates.

Sir Alfred Mond replied that he was informed that was not the case.

Major Prescott rejoined that the report recommended a contributory scheme, which would not involve any charge on the rates whatever.

Sir Alfred Mond said that any way a contributory scheme would mean a contribution from the State. As to the comparative burdens of rates, Sir Alfred asked the House to remember that since the Balfour of Burleigh report the rates had been relieved as regards police and education charges, and also as to road maintenance. To transform local authorities into mere agents for spending other taxpayers' money would throw upon them a great temptation to incur local popularity at the cost of other people. He had a case of that sort recently brought under his notice in connexion with the infant welfare centres. That temptation could only be guarded against if the responsibility for expenditure was brought directly home. Sir Alfred Mond concluded by asking the House to be satisfied that a strong Cabinet Committee had been appointed to go into the whole question of local administration with a view to some legislation next session.

Captain Elliot, taking up a sharp criticism by Mr. A. Hopkinson of the administration of the late Minister of Health, said it should be put on record that there had never before been such an improvement in the vital statistics of the country as there had been during the administration of Dr. Addison, who was entitled to the credit of that achievement.

The motion was defeated by only a single vote, despite the fact that the Government Whips told against it. The figures were: Ayes, 48; Noes, 49.

Dr. Addison.

None are better able to judge of the value of Dr. Addison's services during his period of office as Minister of Health than the medical members of Parliament. The following resolution was unanimously adopted at a meeting on April 11th:

That the medical members of the House of Commons express a cordial appreciation of the services of the Right Hon. Christopher Addison, M.P., as Minister of Health, and congratulate him on the excellent work he has done in the face of many difficulties. They wish to place on record their admiration for his zeal and devotion to duty, and his untiring work in the interests of public health.

Civil Service Estimates.

The estimates for Civil Services for the year ending March 31st, 1922, have been issued in a series of White Papers.

Ministry of Pensions.—For the Ministry of Pensions the total estimate is £111,556,666, which represents a net decrease of £11,678,334. The cost of the medical services amounts to £11,153,000, made up as follows: Salaries, wages and allowances

of medical staff, including fees to members of medical boards, medical referees, etc., £2,277,000—an increase of £451,000; travelling and incidental expenses of medical staffs, medical boards, etc., £51,000—an increase of £26,000; travelling and incidental expenses of disabled officers, nurses and men attending medical boards, etc., £890,000—an increase of £24,000; medical treatment of disabled officers, nurses and men who have left the service, £6,508,000—a decrease of £1,402,000; expenditure in connexion with the provision of artificial appliances for disabled officers, nurses and men, £900,000—an increase of £374,000. In the sum already mentioned for salaries, wages and allowance of medical staff appear among many others the following particulars: Director-General of Medical Services £1,800, Deputy Director-General £1,500, Principal Medical Officer, £1,300, Chief Commissioner of Medical Services £1,350. Sixteen principal medical officers (at £1,200), £20,000. Three hundred and nineteen medical officers (at salaries varying from £750 to £1,100), £287,900. Fees to medical board, medical referees, part-time medical officers, etc., £1,450,000, as compared with £1,250,000 for the previous year. All the salaries and fees named above are inclusive.

Ministry of Health. For the Ministry of Health the estimates show a total of £24,345,098, being a net decrease of £3,342,099; the sum allotted to part-time medical referee consultants is £40,000—a decrease of £20,000; and the sum allotted for medical referee service, fees for nurses, etc., is £31,850—a decrease of £2,000. The miscellaneous grants include: Maternity and child welfare, £1,100,000—an increase of £323,000; treatment of tuberculosis, £1,210,000—an increase of £510,000; treatment of venereal disease, £420,000—an increase of £137,000; grants for the welfare of the blind, £100,000—a decrease of £9,000; grants to voluntary hospitals in respect of spirit duty, £3,500. In the total figures already given of £1,959,076 for salaries, wages, etc., for the Ministry of Health the amount for the medical staff is relatively small. The principal figures are: Chief medical officer, £2,000; six senior medical officers (at salaries ranging from £1,200 to £1,400), £7,899; fifty medical officers (at salaries varying from £600 to £1,100), £39,457; four divisional medical officers, £6,400; thirty regional medical officers (at salaries varying from £1,000 to £1,400), £37,024. Other figures include the remuneration of part-time medical referees and consultants, £40,000 as against £60,000 last year.

Scottish Board of Health.—The estimate for the Scottish Board of Health amounts to £3,375,999, being a net decrease of £573,290. Salaries, wages, and allowances are put at £240,390—an increase of £65,765; part-time medical referee consultants at £9,400, an increase of £5,000; the miscellaneous grants include maternity and child welfare, £180,000—an increase of £105,000; treatment of tuberculosis, £400,000—an increase of £194,000; treatment of venereal disease, £56,000—a decrease of £500; welfare of the blind, £20,000—an increase of £1,500; grants to voluntary hospitals in respect to duty on spirits, £650—a decrease of £100; Highlands and Islands (Medical Services) grant (grant in aid), £42,000. In the total figures already given for salaries for the Scottish Board of Health there are three entries for the cost of the medical department: Nine medical officers (at salaries from £500 to £800) £6,204; two medical referees (at salaries from £1,000 rising to £1,400 inclusive), and three medical referees (at salaries from £1,000 rising to £1,200), the five making a total cost of £5,400. The part-time medical referee consultants, etc., will cost £9,400, of which £3,259 will go in fees to local part-time referees and £4,000 in allowances for specialists.

National Insurance, Ireland.—The Civil Service estimate under this heading is for £618,785, or a net increase of £87,215 on the estimate for the previous year. Salaries include those of two medical officers at £700 a year, and one assistant medical officer at £350—these being unchanged. The main enlargement of expense is for grants in aid of sickness, disablement, and maternity benefit £230,600, and additional benefits £23,000: the two sums standing against £189,800, the amount of the estimate for the previous year.

Board of Education.—The total estimate for the medical department of the Board of Education is £17,441, as compared with £16,373 for the previous year. The present holder of the position of Chief Medical Officer, being also Principal Medical Officer of the Ministry of Health (in which capacity he receives a salary of £2,000 a year), has from the Board of Education only £100 a year. The total staff otherwise is nineteen, comprehending a chief medical inspector, a medical staff officer, six medical officers, and eleven inspectors.

Grants to Universities and Colleges. The estimates of grants to universities and colleges of the United Kingdom is for a total sum of £1,416,000, which, with additional grants of £84,000 to the Irish universities, will bring up the total to be paid for the maintenance of university institutions in the United Kingdom to a million and a half sterling. This is in accordance with a pledge given last October by the Chancellor of the Exchequer, and represents an increase of half a million. The figures for England embrace allowances in respect of clinical units at four hospital medical schools in London. The grant to the London Hospital Medical School will thus be £13,000, as against £6,000 in the previous year; that to St. Bartholomew's Hospital Medical School £12,000, as against £5,000; that to St. Thomas's Hospital Medical School £10,050, as against £4,500; and that to University College Hospital Medical School £10,500, as against £4,000. The Universities of Oxford and Cambridge are each to receive £30,000.

The Parliamentary Medical Committee.

At the meeting of the medical members of the House of Commons on April 11th the Public Health Officers (Security of Tenure) Bill was discussed, and the Committee decided to lend it their support. The Coroners Bill was considered, and it was decided that when this bill reached Committee a new clause should be moved to increase the fees paid for *post-mortem* examination and medical evidence. The Dogs Bill was discussed, and it was agreed unanimously to oppose it. The Tuberculosis Bill and the Health Estimates were also considered.

Termination of the War.—In reply to questions on April 4th by Mr. Lyle-Samuel, Lieutenant Commander Kenworthy, and Sir Frederick Banbury, the Prime Minister explained the position as to the statutory termination of the war. The Act of 1918 provides that the date shall be as nearly as possible the date of the deposit of ratifications of the last Treaty of Peace. Mr. Lloyd George reckons that there must be some settlement at an early date between Turkey and Greece and all the other Powers, but also acknowledges that the matter of ratification cannot be left open indefinitely. The Turkish delegates have promised on their return to place the terms offered before the Assembly and to reply to the Allies within five or six weeks. That leaves another three or four weeks before the Turkish position is known.

Local Government Officers' Superannuation.—Sir Alfred Mond (Minister of Health), replying to Mr. Arthur Henderson on April 5th, repeated what Dr. Addison said some time ago, that no legislation on the subject of the superannuation of local government officers can be introduced this session owing to the expense that would be involved.

Public Health (Officers) Bill.—The first reading was given on April 11th to a private member's bill, introduced by Sir Philip Magnus, supported by Sir Henry Craik, Lieut.-Colonel Raw, Sir James Remnant, and Mr. Myers, "to amend the law relating to tenure of office of medical officers of health, sanitary inspectors, and inspectors of nuisances."

County Councils and Tuberculosis Treatment.—In reply to Mr. T. Thomson, Sir Alfred Mond stated, on April 11th, that 143 of the 145 county and county borough councils in England and Wales have made arrangements for the institutional treatment of non-insured tuberculous persons, but in one case the provision so far made extends only to dispensary treatment. The schemes of twenty-seven county and borough councils for the appointment of committees for the after-care of insured and non-insured tuberculous persons in their areas have been approved by the Ministry of Health or its predecessors.

Definitions in Lunacy Acts.—Captain Bowyer asked, on April 6th, whether the Minister of Health would amend the wording of the Lunacy Acts in order to substitute the terms "patients" and "mental hospital" for "pauper lunatic" and "pauper lunatic asylum." Sir Alfred Mond replied that he had nothing to add to the answer given by his predecessor to a similar question.

Pensions Grant for Heart Disease.—Mr. Raper asked, on April 7th, if the sum of £46,000 had been saved in pensions and grants to discharged soldiers suffering from heart disease; and what was the nature of the medical discovery by means of which this saving was effected. Mr. Macpherson said he had no knowledge of the figure referred to. A sum of nearly £4,000,000 a year was at present being paid to men who were pensioned for heart disease. Every effort was being made by the establishment of cardiological clinics with improved methods of diagnosis and treatment to restore the health of men who suffered from this complaint.

Approved Societies and Hospitals.—Colonel Mildmay asked the Minister of Health, on April 6th, whether he was taking any action in accordance with the recommendations of the interim report of Lord Cave's Committee with reference to the disposal, in the interests of hospitals, of the surpluses of approved societies. Sir Alfred Mond replied that a copy of the report had been sent to every approved society with a covering letter, in which the society was urged to give its serious consideration to the question of using part of its disposable surplus (if any) in making payments towards the cost of its patients in hospitals. This was only one of many additional benefits which it was open to societies to provide.

Pensions' Medical Treatment for Tropical Diseases.—Mr. Macpherson, answering Mr. W. Graham on April 7th, said that the Ministry of Pensions made no provision for the medical treatment of men disabled in former wars, and only in exceptional cases would a man need treatment now for a disability incurred so long ago; the question had, however, recently been raised in connexion with certain tropical diseases and was now under consideration.

The Naval Hospital at Yokohama.—In reply to Commander Bellairs, who asked whether the Admiralty could take steps to abolish the Royal Naval Hospital at Yokohama, Mr. Amery said, on April 6th, that the institution was required to receive convalescent cases from Hong Kong during the period of hot and damp weather experienced there. Its abolition would result in a larger number of cases being invalided home from the China station, with consequent inconvenience and expense. Commander Bellairs asked whether the Minister was aware that, although the hospital had some 80 or 90 beds, not a single patient was accommodated during the year 1920, and the

maximum was only 8 in recent years. Mr. Amery said he understood that last year the hospital was not open at the time that the patients from Hong Kong were usually sent, but he would inquire further into the matter and see if any economy could be effected.

Unsweetened Condensed Milk.—Mr. Doyle asked the President of the Board of Trade, on April 7th, whether he was aware of the proposed standard for unsweetened condensed milk being about 12½ per cent. below the minimum cream contents recommended by the great weight of evidence heard by the Committee appointed by the Minister of Health; whether this was against trade interests in this country—the standards proposed by the condensed milk industry, manufacturers, importers, and the trade in this country were based upon the description officially given to this article in the Public Chemists' Report for many years; and whether he would use his influence with the Minister of Health to fix a reasonable standard which could be met by producers in this country, and which importers should be required to reach if they desired to trade here. Sir P. Lloyd Graeme said he was aware that the proposed standard was lower than was recommended by English makers, but he could not accept the various suggestions made by Mr. Doyle. In determining the standard, consideration had to be given, not only to the interest of British manufacturers, but to those of other sections of the trade, and still more to the necessity of maintaining at competitive prices adequate supplies for the requirements of this country.

The Coroners' Remuneration Bill was read a second time on April 6th.

With the dissolution of the Ministry of Food the powers and duties of Food Controller as regards the output of intoxicating liquor were transferred to the Board of Trade. The Government are considering whether any, and if so what, restrictions on the quantity of beer should be maintained.

LONDON AND COUNTIES MEDICAL PROTECTION SOCIETY.

The annual general meeting of the London and Counties Medical Protection Society, Limited, was held at 32, Craven Street, London, W.C., on April 6th. Sir JOHN ROSE BRADFORD, the President, was in the chair, and in moving the adoption of the annual report of the council he referred to the society's continued prosperity. During the year 733 new members had been elected, a net gain of nearly 500, bringing the membership up to well over 6,000. Almost alone amongst societies, this body had not found it necessary to raise the annual subscription above pre-war level. A great depreciation had to be recouped in the value of the securities held, but, inasmuch as these were—at least it was hoped—a permanent investment, the fact of depreciation was not so formidable as might appear. The credit balance on the actual working of the society during the year amounted to £1,755. He added that the results of lawsuits had been in the main favourable, but many cases had been satisfactorily settled out of court. The changing conditions of medical and dental practice had given rise to new dangers and difficulties, which meant increased work for the society in time to come.

Dr. C. M. FEGEN, the treasurer and chairman of council, said that the invested funds of the society amounted to some £30,000, which meant that if the society went into voluntary liquidation—a thing it had no intention of doing—every member would be entitled to take out £5, the equivalent of five years' subscription.

Dr. C. O. HAWTHORNE, while praising the report in general, criticized an item of 15 guineas which had been paid as subscription to the Federation of Medical and Allied Societies. He submitted that the subscription paid by members to their society was for a very narrow and specific purpose, which did not include medical politics. He moved an amendment asking the council to reconsider its decision. Sir JOHN ROSE BRADFORD said in reply that the matter had been considered very fully by the council, which had proceeded under an article definitely empowering it to take such action. Dr. FEGEN also defended the action of the council. Politics, he said, were entirely absent from its deliberations, and the action was taken because it was believed that the Federation could speak for a large number, if not the greater number, of members of the medical profession. The appointment of representatives to the Federation did not necessarily mean that the society endorsed the Federation's policy. The report of the council was then adopted.

Sir John Rose Bradford was re-elected president by acclamation. The vice-presidents, retiring members of council, the treasurer, and the general and financial secretaries (Dr. Hugh Woods and Mr. A. G. R. Foulerton) were all re-elected, with expressions of appreciation for their past services.



The Elswick Works at Elswick, Newcastle-upon-Tyne. (Photograph kindly lent by Sir W. G. Armstrong, Whitworth, and Co.)

EIGHTY-NINTH ANNUAL MEETING

of the

British Medical Association,

NEWCASTLE-UPON-TYNE, 1921.

LOCAL INDUSTRIES.

COAL MINING.

NORTHUMBERLAND and Durham have long been known as the mining district of the North, and Newcastle-upon-Tyne and Coal are inseparably associated. There is evidence that the existence of coal in the district was known to the Romans, and that they used it for domestic purposes, but coal mining as an industry probably dates from the reign of Henry III. This monarch "by his letters patents . . . thought it fit to give them licence to dig coals . . . and to draw and convert them to their own profit. . . ." The industry has steadily developed from that time onwards, and has long been the mainstay of the north-east coast, for, as always happens when coal is plentiful, manufacturers of every kind sprang up and ever expanded in the district. A good idea of the extent of the industry can be gathered from a few facts concerning the Ashington group of collieries, the most important in the district and one of the largest in the world.

Our second illustration is of Ellington Colliery, one of the group, and typical of the very many collieries scattered about the Northumberland coalfield. There are seven shafts in this group, varying in depth from about 35 to 90 fathoms, and an average of about 9,000 tons of coal come to the surface each day. The work employs over 9,000 men and boys, and the collieries support a local population of about 30,000 people.

Much of the labour of "coal getting" is still done by hand with the pickaxe, aided by the use of explosives, but coal-cutting machines of various types, either driven electrically or by compressed air, are coming more and more into use. For bringing the coal from the workings to the shaft ponies and horses are still largely used, and at Ashington nearly 1,300 of these useful animals are employed. Accidents in coal mining are most often due to falls of stone, and to prevent this the roof is supported by timbering. It gives a good idea of the amount of work underground to mention that over 15,000 pieces of timber are used on an average every day.

The ancillary works connected with these collieries are enormous, and include a power plant with an aggregate of forty-seven Lancashire boilers and an electric plant generating current of 5,350 horse-power. Screening the coal is an important process conducted at the bank by

mechanical means, but employing large numbers of boys and older men. The upkeep of the collieries requires staffs of workmen, such as masons, joiners, engineers, and officials of all kinds, while the transit of the coal from the pits calls for the use of extensive railways and rolling stock. A small proportion of the coal is used for domestic purposes, much is exported, but most is employed in local manufactories.

Some of the coalfields in this district have been fully developed and the best seams exhausted, but the advent of mechanical methods and of electricity have rendered it possible to utilize the smaller seams. Coal from this district in the form of coke is the principal fuel used for smelting the ironstone of the North Riding of Yorkshire. It was found that the type of coal was too soft and wasteful to use in its new state for blast furnaces. For years the coking process was carried out by beehive ovens, when any benefit from the waste heat and gases was lost. Means were devised by which the waste heat could be used for boilers, and this was followed by special by-product ovens of various types, which were designed for the separation of gas, benzol, tar, and ammonia. These processes have greatly increased the value of the industry, so that the by-products are now as important as the coke itself. In 1913 the two counties of Northumberland and Durham produced fifty-six million tons of coal, which constitutes a fifth of the total output of the United Kingdom.

Iron and Steel.

The iron and steel industry of this district is also known to have had its origin in Roman times. The ore was probably smelted by the aid of bellows made of bullocks' skins, and large masses of partly melted ore have been found, notably in 1909, at Corstopitum, near Corbridge. There are reasons for assigning to this collection a date approximating to A.D. 350-380. Relatively very little progress was made in the manufacture of iron until 1735, when Abraham Darby succeeded in bringing to the notice of the ironmasters the enormous advantages of coke. From this time onwards we find the County of Durham assuming an important position among British iron producers on account of the fact that the Durham coals are exceptionally well adapted to the production of coke of the best quality. At the present date there are numerous blast furnaces and rolling mills all

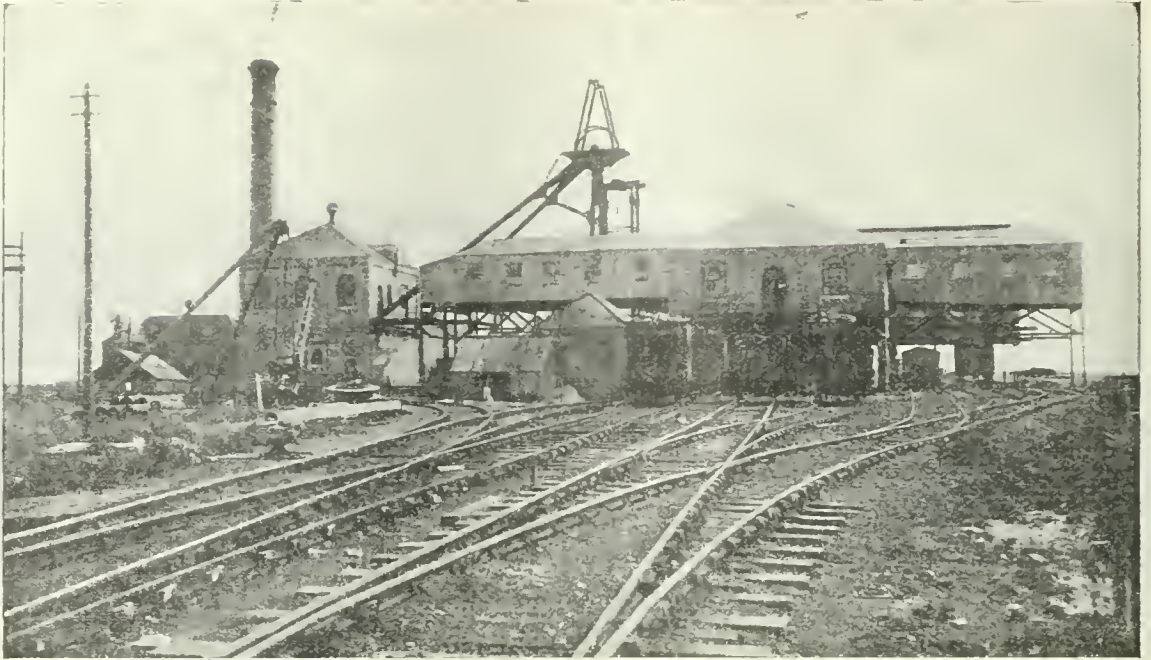

Ellington Colliery, typical of the Northumberland Coalfield. (Block kindly lent by Ashington Coal Co., Ltd.)

over Durham and a few in Northumberland, the ore being mostly obtained from abroad or from the Cleveland district of Yorkshire. These two northern counties yielded about one-seventh of the total British open-hearth steel output in 1913.

There are two firms on Tyne-side that regularly work electric furnaces, whilst two others smelt electrically some of the ferro-alloys employed in the manufacture of high-speed tool steel and other special steels of the highest class.

Ship-building and Marine Engineering.

Another of the great industries is that of ship-building. As far back as 1642 Newcastle was known as the nursery for shipping, and many of the "hearts of oak" that beat the seas in those days were cradled at the Tyne yards. By the nineteenth century, with the introduction of iron for ship-building, the Tyne rose to a position of still higher importance in the industry because of its inexhaustible wealth of iron and coal. The first iron ship to be built on the Tyne was the *Prince Albert*, launched in 1842 from Coutt's yard, now part of the extensive works of Swan Hunter and Wigham Richardson, Ltd. In 1844 Palmer's, of Jarrow, brought out the water tank system for ballast in place of the old system of sand and chalk, and since that day the characteristic "ballast-hills" of Tyneside have steadily disappeared. The development of armoured warships was largely due to the initiative of the Tyne ship builders. This led to the construction, in 1856, of H.M.S. *Terror*, the first armoured ship in the world. The modern cruiser owes its existence to the first Lord Armstrong, of Elswick Works (see illustration, page 577). The first ship of this type was built there in 1884.

Of the naval works on the Tyne, special mention should be made of Armstrong's and Palmer's works. In 1897 Sir Charles Parsons introduced the steam turbine for marine purposes, and it is now used in many forms of

ship. The list of warships built on the Tyne propelled by steam engines is a very long one, and to the various types already mentioned may be added destroyers, submarines, and monitors of several different designs. In recent years oil has to a large extent superseded coal as fuel.

The construction of merchant ships has for long made the north-east coast famous. Some builders have specialized in general cargo boats, whilst others have won fame by building passenger ships and boats for special purposes, such as colliers, trawlers, oil tankers, and other types. The best known passenger and mail steamship of recent years is the Cunard Company's express mail steamship *Mauretania*, built in 1907 by Swan, Hunter, and Wigham Richardson's, and a sister ship to the ill-fated *Lusitania*. Parsons's steam turbines drive her four propellers, and it is a tribute to Sir Charles Parsons's genius that in less than ten years after the appearance of his little ship, the *Turbinia*, it was decided to install turbines of his design in ships which at the time surpassed all others in size.

In conjunction with ship-building, ship repairing has always been an important industry on the north-east coast. Many notable cases of ship surgery have been successfully taken in hand. Floating docks of all sizes have been constructed and exported to all parts of the world. The general equipment of the shipyards on the Tyne is well abreast of the time, and the enormous floating and stationary cranes are famous the world over. The



The County of Northumberland Agricultural Experiment Station, Cockle Park.

tonnage launched from the Tyne and the Wear for twenty years previous to 1914 was rather more than half the total of the United Kingdom.

Marine engineering is also an important industry on the Tyne. This is essentially a modern development, its entire history dating from not more than 100 years ago, but it is of paramount importance where shipbuilding is concerned.

Other Industries.

Electrical industries are also well to the fore: it was on the Tyne in 1879 that the incandescent lamp was produced in a practical form. During the century perhaps the most remarkable industrial development in the district has been the production of electricity on a large scale, both for lighting and as a means of power. In many of the collieries and shipyards it has taken the place of steam, and is becoming more used every year. For considerably more than a century the manufacture of lead has been an important industry in Newcastle, lead ore being extensively mined in Tynedale, Allendale, and Alston, and smelted in the neighbourhood. The local production of the ore now is far from sufficient for the requirements of the lead manufacturers, who import the greater part of their supplies from Spain, Greece, Mexico, and Australia. Quarrying is a very minor industry. The product is limestone, mostly used as a flux in blast furnaces; rather more than three million tons were produced in the two counties in 1913.

Agriculture in Northumberland.

But though the Tyne and its banks together with the south-eastern corner of the county represent a mining and manufacturing district known the world over, the greater part of Northumberland is agricultural. Arable farming, dairy farming, and sheep rearing are each extensively practised, the latter especially among the sequestered hills and valleys of the Cheviot Range:

Where the curlew screams in its wild retreat,
And the fleet hare bounds from its lowly seat;
Where the moor fowl crouch on the heather bed,
And the restless plover wails overhead.

The importance attached to agriculture is reflected at the Cockle Park Experimental Station, where most valuable research work has been carried on since 1896. The tower at Cockle Park Farm (shown in the third illustration) is a reminder of the troublous times when the farmhouses were fortified against the attacks of the dwellers in the "debatable land."

England and Wales.

THE FUTURE OF BRISTOL UNIVERSITY.

At a luncheon which took place at the Royal Hotel, Bristol, on April 7th, Sir Isambard Owen, M.D., Vice-Chancellor, made a speech on the future of the University of Bristol. He asked why the communities of the South-West should not re-establish their former position of leadership in the new era of progress. The important question for industry was, How long would the empire of coal over industry last? It was already threatened by oil, and geologists and chemists were endeavouring to find other substitutes. All round the coast of the West of England were reservoirs of power that needed only to be harnessed to be placed at the disposal of man. A proposal to that end was under consideration, and, if carried out, it would cause a great alteration in existing conditions. The West of England was ready for whatever might happen. A great service had been rendered by the establishment of technical colleges and the advantage of technical knowledge had been proved in recent years.

Having given a description of some of the features of the university buildings, Sir Isambard Owen said that unfortunately the cost of the new developments had increased enormously since the war. Only one-third of the cost of maintenance could be covered by the fees. The Government was doing what it could to add to the resources; the Corporation of Bristol had nearly doubled its grant, whilst the committees of Gloucester and Somerset and the cities

of Bath and Gloucester had undertaken to contribute. The time had come when Bristol University must complete its equipment and make ample provision for its future working. If the universities of England were to preserve their freedom of action, the means must be supplied. A university dependent upon the Government was not free, and when a university lost its sense of freedom it lost in its usefulness, and its output of original work was lessened. Hence an appeal was being made to the public of the entire district that Bristol University was designed to serve.

KING EDWARD'S HOSPITAL FUND FOR LONDON.

The annual meeting of the President and General Council of King Edward's Hospital Fund for London, to receive the accounts and the report for 1920, was held at St. James's Palace on April 12th, with H.R.H. the Prince of Wales in the chair. The total receipts for the year were £480,431, of which £255,365 was the sum received from the Joint Committee of the British Red Cross Society and Order of St. John of Jerusalem. The amount distributed was £700,000; of this the distribution of surplus Red Cross funds in aid of schemes of extension and improvement accounted for £250,000, the emergency distribution £250,000, and the ordinary distribution £200,000. The amount of the emergency distribution was taken from reserve funds held in cash or short-dated securities, as also was the sum needed to maintain the ordinary distribution at its previous figure. The effect of this was to reduce the reserves by about one-fourth, and the income from invested funds by about £16,000. The Council made this sacrifice in the hope that, with the aid of others interested, time might by this means be secured for the reorganization of hospital finances. They consider, however, that any repetition of such a drain on the invested funds and on permanent income would be disastrous to the Fund and to the hospitals. The Council pay a warm tribute to Sir John Tweedy, F.R.C.S., on his retirement from the chairmanship of the Distribution Committee, in which post he has been succeeded by Sir Cooper Perry, M.D. The problem of hospital finance was continuously before the Finance Committee of the Fund throughout the year, and the report ends by calling upon all who believe in the voluntary system to make a special effort to support the hospitals during the present crisis, and to ensure that voluntary contributions form at least a substantial part of their income in the future. The Prince of Wales in his short address voiced the general feeling of the Council when he said: "I think we are all very glad that Lord Cave's committee have reported so decidedly in favour of the voluntary system of hospital management."

THE GREAT NORTHERN HOSPITAL.

The Committee of Management of the Great Northern Central Hospital, Holloway, having considered a report of the Conference on National Health convened by the Faculty of Insurance, has expressed the following opinion for transmission to the British Hospitals Association and the press:

(a) Insured persons treated both as in- and out-patients should be paid for in full by approved societies.

(b) Payment should be made to the hospitals by the societies concerned by means of capitation grants, and not by the handing over of lump sums.

(c) In view of the general public's limited opportunities of gaining knowledge of voluntary hospital questions, an effort should be made to form a Volunteer Hospitals Publicity and Propaganda Committee, towards the funds of which all hospitals should be invited to subscribe according to their number of beds and out-patients.

(d) Such a Committee should consist of hospital representatives with some of the best publicity experts. It should endeavour to promote the interests of voluntary hospitals generally, and leave it to individual institutions to make known their particular needs.

ANTHRAX IN SHAVING BRUSHES.

Dr. William J. Howarth, Medical Officer of Health for the City of London, in his last monthly report refers to the circular letter by the Ministry of Health indicating the action to be taken in connexion with cases of anthrax attributed to the use of infected shaving brushes, an account of which was given in the *BRITISH MEDICAL JOURNAL* of February 5th, 1921, p. 207. A method of partial disinfection of all brushes was described in the

circular, but, as Dr. Howarth points out, complete sterilization of the brushes is impracticable, and while the formalin method may be relied upon to free the exposed part of the hair from infection, it does not affect spores embedded in the handle of the brush. He records that in the City of London he received every assistance from the various city traders who had been affected by the discovery of anthrax in Japanese shaving brushes. They all, without exception, readily complied with any suggestions made by him, and many of them voluntarily asked him to undertake the destruction of their stock of suspected brushes rather than incur the risk that would attach to their sale. A table is given in the report showing the numbers of each pattern of brush that had been destroyed up to March 12th, 1921. In all, 13,224 brushes were destroyed, and one box of bristles. In each case a certificate of destruction was issued to the owners.

Scotland.

CONFERENCE OF SCHOOL MEDICAL OFFICERS.

THE Association of School Medical Officers of Scotland held a conference in Edinburgh on April 7th and 8th, with Dr. A. E. Kidd as president. At the opening session Dr. John Macpherson said that it was an extraordinary thing how little attention had been directed to the great promise for the future that the medical examination of school children held out. Apart from its remedial and preventive functions, it should eventually introduce a general survey of the population whereby the utility of each citizen would be known and placed at the service of the State. Defects which the recruiting for the army had shown up might have been avoided if the system had been in existence thirty years ago. Dr. F. C. Shrubbsall, medical officer of the London County Council, spoke on the subject of mental deficiency. He pointed out that the individual must be treated as a whole, and that it was not sufficient to say because a boy failed to pass nine out of ten tests that he was defective; it depended on a study of the history, the physical examination, and the clinical examination of the individual. Family history also was of importance, but it must not be overweighted. In mental testing it was usual to assess general intelligence by one or other of the graduated series of tests, but it was important that these tests should not lay too much stress on verbal imagery. In assessing the individual the certifying officer ought to feel sure that with a similar upbringing and in similar conditions he himself would have acted differently.

At the second session, which was presided over by Professor A. Darroch, chairman of the Edinburgh Education Authority, Dr. Norman Walker spoke on skin diseases in school. He said that pride of place among skin diseases in schools must be given to scabies. In every war scabies had been one of the chief causes of incapacity, and after every war the facts regarding it had been carefully collected, carefully printed in reports, carefully bound—and carefully put away. If a tenth of the skill that was put into tracing small-pox contacts were devoted to scabies it could very soon be absolutely stamped out. A more difficult problem was that of ringworm. It would be of enormous value in the campaign for the removal of that disease to know the actual number of children who were absent from school on a given day on account of ringworm. In the towns it would be found to be a number which would be rather surprising. At the afternoon session, with Dr. J. Mattie in the chair, Dr. Angus MacGillivray, reader in Ophthalmology at St. Andrews University, spoke on "The educationally blind child." He said that the rational treatment of short sight should be based on an accurate knowledge of the causes of the condition, such as holding a book too near the eyes and stooping over the work, especially in bad light and bad hygienic conditions. Proper posture while at work should, therefore, be insisted upon. The children at the Myope School were educated without any books, the teacher at the blackboard being the book. The chief feature of the teaching at the Blind School was that the pupils were taught to do their work sitting erect, stooping being prohibited, and after a few weeks the child was quite

independent of his eyes for near work, learning to read his Braille type by touch.

On the following day the conference was resumed by a lecture by Professor Georges Dreyer of Oxford University, on "The assessment of physical fitness," with Sir Leslie Mackenzie, of the Scottish Board of Health, which had arranged the lecture, in the chair. Professor Dreyer said that those who were concerned with the question of physical fitness were often faced with the difficulty of making up their minds definitely whether they were face to face with people who were of a lower kind of physique than they should be. In the past investigators had had to rely largely on their impressions, helped by certain measurements. Most of the existing tables dealing with the size of the normal human body were based on the theory that definite relationships existed between the age, height, and weight of the individual. His own conclusions were that there was no definite relationship between age, height, and weight which could compare in accuracy with the relationship which did definitely exist between weight, trunk length, and the circumference of the chest—relationships which were unaffected within wide limits by age. Recreation, occupation, and disease affected very considerably the development of the legs, so that the height was an uncertain and unsatisfactory measure to use in relation to weight. After the lecture a demonstration of the apparatus and methods of measurement was given by Dr. F. G. Hobson of Oxford University. At the afternoon session, which took the form of a joint meeting with the Scottish League of Organizers and Teachers of Physical Training, the subject of discussion was "Physical education," Mr. James Malloch being in the chair. The discussion was led by Dr. Alister Mackenzie, Principal of the Dumfermline Training College, who appealed for co-operation between the physical training expert and the school medical officer.

GYNÆCOLOGY AT THE EDINBURGH ROYAL INFIRMARY.

At a meeting of the managers of the Edinburgh Royal Infirmary, on April 4th, reference was made to the expiration of Dr. A. H. Freeland Barbour's term of service as gynaecologist to the Royal Infirmary. The managers placed on record their recognition of the skill and attention he had brought to bear on the duties of his office during the thirty-five years of his connexion with the department, and of the sympathy and tender care patients had received at his hands. In consideration of his valuable services he was unanimously appointed consulting gynaecologist to the institution. At the same meeting regret was expressed at the loss of the services of Dr. N. T. Brewis, who was appointed assistant physician in 1901, and in 1906 took charge of one of the gynaecological wards. The managers placed on record their sense of his eminence as a clinician, which, along with his sympathetic manner, not only endeared him to his patients and colleagues, but secured for him the esteem of the profession generally. It was agreed to ask him to accept the post of consulting gynaecologist.

HOUSING IN SCOTLAND.

The annual Scottish National Housing and Town Planning Congress will take place in the City Chambers, Edinburgh, on April 19th and 20th, with Sir Henry Ballantyne, Chairman of the Royal Commission on Housing in Scotland, in the chair. The Congress will be attended by representatives of county councils, town councils, architectural and technical associations, and associations of employers and workers, and will consider various housing and town-planning questions, more especially those of an urgent character, such as the need for the adherence of the Government to the programme for which legislative provision was made by the various Acts of 1919. The fixing of rents, housing finance, the management of housing estates, standards of construction and design, and the preparation of schemes for carrying into effect the recommendations of the Royal Commission on Housing in Scotland, will also be under the consideration of this Congress.

PROFESSOR LUIGI CAROZZI, medical inspector of industry and labour in Italy, has been nominated head of the Service of Hygiene at the International Bureau of Labour in Geneva.

Correspondence.

THE SCIENCE OF ETIOLOGY, OR THE NEW EPIDEMIOLOGY.

SIR,—Your "distinguished bacteriologist" says that the method of the newer epidemiology, "instead of accumulating facts in laborious fashion, aims at a solution of the problem by postulating causes, and apparently by eliminating the principle of specificity."

What "new" epidemiologists renounce the laborious accumulation of facts? Is it Dr. Brownlee, whose conclusions are based upon many years of clinical experience as well as upon the statistical records of generations? Is the Medical Officer of the County of London really an epidemiological Lady of Shalott isolating herself from the laboriously accumulated facts of disease?

Because there is a whole group of etiological momenta common to the enteric group of diseases, another group common to the venereal diseases, many epidemiological affinities between scarlet fever and diphtheria, and so forth, and because epidemiologists, whether "new" or old, subject these factors to statistical or historical examination, is there any sense in accusing them of eliminating the "principle of specificity"? One may recognize something without perpetually chattering about it.

If any "new" epidemiologist supposes that the whole problem of etiology can be solved by doing sums or by reading the collected works of Sydenham, he must be a very foolish man. If any bacteriologist thinks that the elimination of, say, epidemic disease of the typhoid group can be secured by immunizing the population first against *B. typhosus*, then against paratyphoid A, paratyphoid B, paratyphoid C, and so on to the end of the alphabet, all other things remaining constant, he must be rather naïf. I have not myself met an epidemiologist of the former or a bacteriologist of the latter class, and surmise that the names of such persons are John Doe and Richard Roe.

I do not believe that anything is gained by setting up these scarecrows; your distinguished correspondents can surely do something better than that.—I am, etc.,

Loughton, April 10th.

MAJOR GREENWOOD.

TRANSFIXION OF THE BODY.

SIR,—In your issue of April 9th Dr. S. D. Clippingdale has referred (p. 550) to the specimen of the gig shaft now preserved in the Museum of the Royal College of Surgeons, London, but with such lamentable surgical inaccuracy that I feel it incumbent to put the real facts of the case before your readers. I may cite, with omissions, from the account as given in the last edition of the *College Catalogue*, 1915, drawn up by Mr. C. F. Beadles and myself. Besides the gig shaft (No. 2241.2), which is perfectly entire, the Museum contains part of the anterior wall of the thorax (2215.2), through which the shaft was driven ten years before death. The shaft entered on the left side, between 3 in. and 4 in. from the sternum, was driven across the mediastinum, and passed out of the thorax about 3 in. from the right side of the sternum, between the second and third ribs; the tug iron of the shaft penetrated the chest and the lung rather lower down on the left side, between the third and fourth ribs. The patient, in the circumstances cited by Dr. Clippingdale, felt the end of the shaft perforate his side under the left arm, which was raised high up, and as the horse continued plunging he felt it pass from under his right arm. The patient's cries very shortly brought assistance, and the horse having been put back, he, with the aid of those who had come to him, drew himself off the shaft on which he was impaled. On the ninth day it was first thought prudent to move the patient sufficiently for completely undressing him and examining the wound; from this time he gradually recovered.

Placed immediately before this there is also in the College Museum (No. 2215.1) the pivot of a try-sail mast which passed completely through the body of a sailor, traversing the chest and upper part of the abdomen; complete recovery ensued. An excellent water-colour drawing of the patient made by Cliff, the first conservator, is exhibited by its side; the drawing shows the healed entry and exit. The pivot, after passing obliquely through the body, penetrated the

deck. The mast was 39 ft. long and about 600 lb. in weight. The man was carried to the London Hospital, where, under the care of Mr. John Goldwyer Andrews, he recovered in five months so as to be able to walk. He ultimately returned to his duty as a seaman.—I am, etc.,

S. G. SHATTOCK, F.R.S., F.R.C.S.,
Pathological Curator, Royal College of Surgeons
of England.

April 15th, 1921.

ASTHMA AND ANAPHYLAXIS.

SIR,—In response to Dr. James Adam's letter of March 26th and other letters, for which I beg to thank the writers, commenting on my article of March 12th, I should like to make the following observations:

We may liken the solving of the asthma problem to doing a difficult jigsaw puzzle. The first thing to do is to display all the pieces, if none are missing; the second to fit them in to each other; we may then admire the completed picture. Now I only claim that anaphylaxis is an important "piece" and that it can be shown to fit many other pieces, but it is not the whole picture, nor do I think it any simplification to say, as Dr. Adam does, "The extreme sensitiveness displayed by these patients to minute doses of hundreds of substances, harmless to ordinary individuals, indicates an extraordinary unstable metabolism." I think it indicates anaphylaxis, or, at any rate, it is simpler to say so.

On the other hand, I know Dr. Adam's most excellent book almost by heart, and have been able to cure many patients simply by conforming rigorously to the early evening meal, the weekly starvation, and purge.

But again this is only a piece of the puzzle and not the whole picture; nevertheless it very nearly fits the anaphylactic pieces. In this late meal, overfeeding, week-end, type of case, complete digestion and the breaking down of proteins to peptones and amino-acids is interfered with. The stomach is given more than it can deal with, or the starches, fats, and proteins may be so intimately mixed in the cooking that the proper digestive fluid and service for each is unable to reach them. Un-broken-down proteins may then pass through the intestinal wall, whence, unless stopped by the liver, they will enter the general circulation, initiate a "hémoclasique crisis" followed by an attack of asthma some hours later, that is, in the middle of the night.

Surely the essential condition in the lung is a spasm of the bronchiole muscle, which has been abundantly demonstrated in sensitized animals. The lungs of a sensitized animal are removed from the body and alternately expanded and deflated with an air pump, they are then perfused with a fluid to which the animal is sensitive; the bronchiole muscle at once shuts down and the typical picture of asthma occurs. I do not find the week-end type as common as Dr. Adam does, and there would be no difficulty in parading a dozen asthmatics who started their asthma during the war under those ideal conditions which one knows stopped not only asthma but migraines and many other of these chronic complaints.

Dr. Adam finds a flaw in the anaphylactic theory of asthma because of the periodicity of the asthmatic attacks, which periodicity is absent in anaphylaxis. My argument is that asthma is an anaphylactic phenomenon and will occur each time an exciting dose of the protein enters the patient who is sensitive to it, whether it be in the Christmas holidays every time the small boy empties a plate of nuts, or three times a week during the hunting season, or every week-end when Demos fills himself up to the neck. It is not a periodicity of the asthma but of the cause of this anaphylactic symptom.

I join most heartily with Dr. Adam in his call for research, for which asthma and these allied complaints offer an immense field. Who will tell us what the eosinophilia means? Or why, when I obtain a skin reaction to oats as big as a halfpenny, does the child not become covered with urticaria after a plate of porridge, but instead has an attack of asthma?

The inter-relationship of asthma or sensitization and tuberculosis is too complicated to touch on in a short letter, but extremely important. With regard to giving serums by the mouth, others are better qualified than I am to answer this. New French work suggests that mixture of sodium hyposulphite with the serum will obviate anaphylactic symptoms. I have not the paper by me, but will

send the reference to Dr. Allison. But in no case should horse serum be given to asthmatics—so many of them are sensitive to horse, so that the first dose is poisonous. Most of the deaths that have occurred after horse serum have been in these horse asthmatics.—I am, etc.,

London, W.I, April 11th.

FRANK COKE.

ADRENALINE IN RESUSCITATION.

SIR,—I have read the letter of Lieut.-Colonel Marjoribanks, in your issue of April 9th, in which he asks me one or two questions.

I agree with him that dilution of drugs with the blood can be secured to any extent, and that the rate of injection of an intravenous solution is quite as important as the strength of the solution.

There is one point, however, which he misses in relation to resuscitation. A person who has been drowned, or is in a state of what we may call temporary death, is necessarily a person whose circulation has stopped. Under such circumstances it is quite useless to inject any drug into the blood, as it cannot have any effect owing to the absence of circulation to carry it on to those parts of the body where it can act. Adrenaline acts upon the peripheral vessels of the circulation, chiefly upon the peripheral arterioles, and in order to get it there when we are using adrenaline for the purpose of resuscitating any body, it is necessary to temporarily establish an artificial circulation in order to carry the drug to the periphery. For this reason the intravenous infusion of saline solution, or gum solution, is necessary in a quantity of two pints, or even more. Adrenaline must, I think, be introduced in this solution in a dilution of about 1 in 50,000, or a small quantity of liquor adrenalini hyd. (B.P.) must be injected into the circulation while the infusion is in progress. It would, in my opinion, not be safe to give a 10-minim dose of adrenaline and follow this with the saline infusion, as too big a dose of adrenaline would reach the peripheral circulation at one time. For this reason I advocate the use in such cases of diluted adrenaline solution in the infusion fluid.

It is just here that the necessity comes in for a person skilled in adrenaline transfusion being present, as it is impossible, so far as I am aware, to lay down an exact rule with regard to the dose of adrenaline that will have to be administered. Infusion should be stopped as soon as the heart starts and the circulation is re-established, and then resumed in small quantities if the circulation shows further signs of failing. The action of adrenaline is violent, even in minute doses, and also very transitory, its effects disappearing in about two to three minutes.

I am afraid I cannot answer Colonel Marjoribanks's last question more accurately than to say that I believe that where the circulation has stopped it will be necessary to give an intravenous infusion of water, or better still salt solution, containing adrenaline in the dilution of about 1 in 50,000, up to from two to three pints, and that when this has been administered the heart will probably restart, either by itself, or with a very slight stimulus, such as the prick of a needle, or pressure from without through the chest wall.—I am, etc.,

J. P. LOCKHART-MUMMERY, F.R.C.S.

London, W., April 9th.

IRRITABLE BLADDER.

SIR,—The condition described by Dr. James Hamilton (March 26th, p. 480) seems to me to be especially dependent on the loss of normal contractility of the perineal portion of the urethra. This portion has the thinnest and most easily dilated walls, and in these cases it is always possible, after the bladder has been emptied, to squeeze from it a few drops of urine.

These patients are always told to empty the bladder and even to "milk" the prostate; the real object, however, should be to empty that part of the urethra thoroughly. If this is not done the small quantity of urine retained becomes, I believe, inspissated by absorption of its water, and so more irritant. The more irritant the urine in the first place, the more irritant is the inspissation, and hence one cause of occasional excess of irritability.

The emptying of this part of the urethra should be done by pressure with the fingers from the anus to the front of the perineum, repeated fifteen to twenty times after micturition, the anterior portion being also carefully

emptied until no further drop can be squeezed from the fossa navicularis. Any retained urine tends to be passed down to the fossa, so that an examination fifteen or twenty minutes after micturition will show whether the process has been successful, and any residue should be got rid of. If this is thoroughly carried out the intervals between micturition are at once lengthened. The rigour of treatment may be relaxed after a time, but vigilance is always necessary.

The theory of inspissation has not been verified, but the success of the treatment is a practical fact.—I am, etc.,

April 5th.

OCTOGENARIAN M.D.

SALVARSAN AND THE WASSERMANN TEST.

SIR,—In the issue of the JOURNAL dated March 19th, 1921, is published a paper on the treatment of syphilis by salvarsan. In that paper it is laid down that (1) salvarsan exercises a direct lethal action on the *Spirochaeta pallida*, and that (2) the Wassermann test indicates the presence of living spirochaetes.

Are we to conclude that this teaching is now accepted generally by the profession, and, if so, is it then the duty of those who undertake the treatment of syphilis to persevere with salvarsan until the reaction is negative, and is one to look upon all who exhibit a positive Wassermann reaction as requiring salvarsan treatment?

On the same morning lately I saw two patients. One was a woman with untreated syphilis of five years' standing and undoubtedly ill. Her reaction was negative, but became positive after a dose of salvarsan. The other was a man of 65, who admitted to gonorrhoea forty years ago but was positive he never had syphilis. Being a seafaring man he was naturally expert in the diagnosis of syphilis, and I believed his statement. He had none of the stigmata of congenital syphilis, and no signs of parasyphilis. His reaction was strongly positive. The tests were carried out by Professor Beattie of Liverpool—a sufficient guarantee of their accuracy.

Such experiences are not uncommon in venereal work, but they do not seem capable of explanation by the generally held views.

Is it not possible that salvarsan, instead of directly killing the spirochaetes, stimulates the body to do so by affecting its particular mechanism of defence against syphilis, and that it is the activity or lack of activity of this mechanism of defence which is demonstrated by the Wassermann reaction?

In the *Medical Century* (1914) is reported an experiment conducted by a Dr. Mellon of America, who administered to healthy students large quantities of a drug known as *Baptisia tinctoria*, causing the production in their blood of an agglutinin which would agglutinate typhoid bacilli, and proving thereby that a drug could be as successful an antigen as the disease toxin, and could influence the serum reaction in the same way as the disease.

In the light of this view the phenomenon of a positive reaction after a provocative dose of salvarsan is explained by the stimulation and resuscitation of a temporarily overwhelmed resistance. Looked at from the more generally accepted point of view it is difficult to explain, as, if salvarsan kills spirochaetes and the positive Wassermann is a proof of living spirochaetes, the chances of a negative reaction after the provocative dose ought to be greater than before it was given.

If salvarsan does act by stimulating the body's mechanism of defence against syphilis, may it not overstimulate it, paralyse it, destroy it? The negative Wassermann reaction, after a course of treatment, may mean a paralysed defence, with its increased liability to reinfection, relapse, or an earlier advent of the parasyphilides.

If this is so, then damage is being done every day with conscientious thoroughness.—I am, etc.,

Liverpool, April 5th.

F. B. JULIAN, M.B.

GLANDULAR FEVER.

SIR,—During the eleven years that I was school medical inspector to the West Riding County Council I had the opportunity of seeing a very large number of children suffering from the condition which Drs. Letheby Tidy and Morley call glandular fever. The symptoms were always the same—slight malaise and pyrexia, and com-

plaint of sore throat and difficulty of swallowing out of all proportion to the very slight objective changes that were observed in the fauces. The characteristic symptom, however, was the enormous enlargement of the sub-maxillary and peritonsillar lymphatic glands. This enlargement started on the second day of the disease, and continued to increase for about a fortnight, then remained stationary for some weeks and very gradually subsided. In many cases the condition of the glands suggested that they were going on to abscess formation or had become tuberculous, but I can say definitely that in no case did either abscess or tubercle develop.

The disease was met with always in epidemic form. I was able to fix the incubation period at three days. The epidemics were usually somewhat extensive, in many cases involving 25 to 40 per cent. of the children attending the same school. The last epidemic that I remember was at Adel School, near Leeds, in, I think, 1917. Epidemics of this disease were extremely frequent on the South Yorkshire coalfield, and in the neighbourhood of Leeds. The public invariably called the condition mumps. I have never seen the disease outside the West Riding of Yorkshire.

My attention was first called to the condition from noting how very frequently epidemics of mumps were recorded in the schools in the West Riding. During some years I kept a record of the cases I had seen. They numbered several hundreds, but I regret that at the present moment I cannot put my hand upon my records.—I am, etc.,

DUNSTAN BREWER,
Medical Officer of Health.

Swindon, April 9th.

SCURVY IN A BREAST-FED INFANT.

SIR.—In the review of Professor A. F. Hess's *Scurvy Past and Present* (BRITISH MEDICAL JOURNAL, January 15th, p. 85) he is said to make a statement to the effect that "infants brought up on natural milk do not contract scurvy." Some four or five years ago a strong, stout, healthy country woman whom I had confined, brought her child, only a few months old, to me, very bad indeed with scurvy. After examining the child I said, "If you lived in London, I would say your child had scurvy," and added that I had not seen a case for over fifteen years. Luckily I finally decided that it was scurvy in spite of the fact that the child was purely breast-fed, and I ordered orange juice, etc. On questioning the mother I found that she had been practically living on pickles, vinegar, and bread. The child was purely breast-fed, and on altering the mother's diet, etc., the child rapidly recovered.—I am, etc.,

A. NORRIS WILKINSON,
M.R.C.S., L.R.C.P.

Inglewood, Vic., Australia,
February 26th.

MEDICAL REGISTRATION.

SIR.—In view of recent legislation and prospective regulations, I am directed to remind you that a medical practitioner, no matter what qualifications he may possess, is not "legally qualified" or "duly qualified" unless he is registered; and that the *Medical Register* is alone evidence upon this point "until the contrary is made to appear." There is no other book of reference which takes its place.

I am always pleased to answer inquiries by telephone (Langham 2500), or, better still, by letter, and to give all the information I possess in regard to practitioners. For those who specially require them, lists are prepared each month giving the names of all those registered during the month, and also of those who have died or whose names have been removed from the *Register* for any other reason.—I am, etc.,

NORMAN C. KING,
Registrar.

General Medical Council,
44, Hatfield Street, London, W.1,
April 7th.

THE Government of Panama have assigned ten million dollars for the erection of an institute for tropical diseases in memory of the late Surgeon-General Gorgas.

THE second congress for Italian sanitary industries will be held at Parma in June, a little more than a year after the first congress, which was held at Milan. There will be an exhibition of medicinal plants and pharmaceutical apparatus and accessories.

Obituary.

PETER THOMAS DUNCAN, M.D.

Consulting Physician, Croydon General Hospital.

WE regret to report the death, which occurred with tragic suddenness on Wednesday, April 6th, of Dr. Peter Thomas Duncan, of Croydon, in his 73rd year. He was acknowledged in the town as *facile princeps* in diagnostic skill. When in doubt or difficulty his aid was frequently sought by his brethren, and readily given to the last, for he died in harness, as he wished. His early life was a constant struggle against difficulty, but his indomitable pertinacity overcame all, and his career was distinguished. He received his medical education at University College Hospital, and in 1874 graduated M.B. with honours and B.S. with gold medal in surgery in the University of London. He took the M.D. in 1876, when he qualified for the gold medal. He held the office, then called physician's assistant, now known as house-physician, and was a Fellow of University College.

He settled in Croydon and became physician to the Croydon General Hospital. From 1885 to 1893 Duncan was secretary of the East Surrey District of the British Medical Association, and in 1897 was president of the South-Eastern Branch.

The tributes we are able to publish from Sir Rickman Godlee and from Sir James Purves Stewart will explain Dr. Duncan's qualities as a practitioner of medicine. He was also remarkable for his sound judgement and wise forethought in business affairs. He was from an early date head of a large partnership in Croydon, and in recent years had organized it thoroughly on the team system. The aim he had was to ensure continuity of treatment to the patient, an opportunity to each partner to follow his particular bent in practice, while ensuring to all greater stability and security. Dr. Duncan leaves a widow, a son, and three daughters, who with a large circle of patients and friends, mourn his loss. He was a cousin of the late Dr. Matthews Duncan, and a brother of the late Dr. William Duncan, gynaecologist to the Middlesex Hospital.

Sir RICKMAN GODLEE, Bt., who was a fellow student, writes: My feeling on hearing of Peter Duncan's death was that another familiar friend had gone; yet we had seldom met in past years, and probably should not have met again, for I, like so many others, had deserted my post, while he remained at his to the end. The real familiar days were long ago at University College in the seventies. There I remember him as a merry, hard-working student, who took many honours, held a resident appointment, was hail fellow well met with every one, and was liked and respected by us all. Then came the striving and penurious days of junior staff appointments, when I heard almost with jealousy of Duncan doing a large practice, but did not see much of him till I was old enough to be called into consultation. After that came many pleasant meetings scattered over many years. I looked forward to his genial welcome and his breezy manner and the pleasant chat over former days. But chiefly I was struck by his skilful and careful methods of diagnosis, his medical instinct, and his wisdom. He was one of those general practitioners from whom consultants, if they are wise, can learn much. There is no other way of picking up a very essential part of their knowledge, and few were so well able as he, though quite unconsciously, to impart it. And he was the leader and inspirer of a very vigorous band of colleagues; it is no small thing to be not merely one but the acknowledged head of such a distinguished body of men.

Sir JAMES PURVES STEWART writes: The news of Dr. Peter Duncan's death will be heard with sorrow by a wide circle of professional colleagues and friends. Starting his professional life with academic distinctions of the highest order, Dr. Duncan, in the course of a long and honourable career, accumulated a wide and deep knowledge of his profession and a shrewd judgement of men and affairs. Throughout a busy life his knowledge and experience were always freely at the disposal of his colleagues, many of whom, in moments of difficulty, turned to him for counsel and support, which were always freely forthcoming. A man of singular modesty and charm, his code of honour was a lofty one, and he was incapable of an ungenerous

thought or action. His friends, colleagues and patients, not only in Croydon but throughout the country, will condole with his widow and bright young family in their irreparable loss. He leaves behind him the memory of an upright man, a loyal friend, and an able physician—a heritage even more to be desired than the eminent position to which he deservedly attained.

J. HOPKINS WALTERS, M.R.C.S.,

Consulting Surgeon, Royal Berkshire Hospital, Reading.

With the death of Dr. James Hopkins Walters of Reading, at the age of 76, there passed away a notable character. Dr. Walters, who was a student at Guy's Hospital, took the diploma of M.R.C.S. in 1865, and he practised during his earlier days at Faringdon, Berks. In 1878 he moved to Reading, where he soon became one of the leading practitioners in the town, a position which he held until his retirement in 1913. He was on the active surgical staff of the Royal Berkshire Hospital from 1879 to 1904, and was then appointed consulting surgeon. He was president of the Reading Pathological Society for two years.

In his younger days Dr. Walters was a keen sportsman and an excellent shot; he also took a great interest in the Volunteers, in which for many years he was a surgeon-captain. In local politics he was a force with which to reckon, and he sat for a considerable period on the Reading Town Council. Always a fighter he had no hesitation in calling a spade a spade, and he stated his views, often original and always distinguished for sound common sense, in vigorous and picturesque language. He was a versatile writer, both in the medical press and in the lay journals. Although of the older school of medical men he was always receptive of new ideas. Even after relinquishing active practice in Reading he made a voyage half way round the world as a ship's surgeon. On the outbreak of war he volunteered for various posts which the authorities, on account of his age, were unable to grant him, and eventually he acted as medical officer to the regiment quartered in the town and to two V.A.D. hospitals.

On the eve of his death he had seemed in better health than usual, and had indeed played a game of billiards with keen interest at his club. Death occurred on March 4th suddenly in his sleep, as he had always desired—he was ever impatient of illness in himself.

JOHN WILLIAM FRY, M.R.C.S., L.S.A.,

Maidstone.

MAIDSTONE has recently lost the doyen of the local profession in the person of Mr. John William Fry, who died shortly after entering upon his 90th year.

Born at Greenwich in 1832, he was educated privately, and was in 1849 apprenticed to his uncle, Frederick Fry, F.R.C.S., surgeon to the West Kent Hospital, Maidstone, a gentleman of irascible temperament, who in the High Street once horsewhipped a fellow practitioner, and on another occasion hurled a row of filled medicine bottles at his unfortunate nephew's head. Harsh as were the conditions, Mr. Fry gained valuable experience, including that of cholera, an epidemic breaking out amongst immigrant hop-pickers at East Farleigh, attended with great mortality, the victims being buried in a common grave.

Leaving Maidstone, Mr. Fry entered at King's College Hospital, where he studied under Partridge and Ferguson. In 1855 he obtained the diploma of M.R.C.S. Eng., and became ship's surgeon to Messrs. Green and Co., sailing first to Australia and next to India in the *Nile* troopship, which reached Madras Roads a month after the outbreak of the Indian Mutiny, the troops being landed at once and rushed up to the relief of Lucknow. Returning to London Mr. Fry took the L.S.A. in 1859 and entered into general practice at Thaxted, Essex, where he again encountered a cholera epidemic at Great Sampford, taking up his residence in the stricken village and receiving the thanks of the Privy Council for his devoted services. In 1868 he moved to Watlington, Kent, where he practised for twenty-nine years, retiring to Maidstone in 1897, but again putting on harness to assist his fellow-townsmen in the typhoid epidemic which visited the town in 1898.

From his long connexion with Maidstone Mr. Fry was well known and much respected, and although he reached an advanced age, his interests remained many and his faculties unimpaired. He was an old member of the British Medical Association, and the oldest member of the Kent Medical Benevolent Society at the time of his death. He leaves three sons (all in the medical profession) and one daughter.

DR. CHARLES ALBERT HINGSTON of Plymouth died on April 5th, aged 78. He was educated at St. Bartholomew's Hospital and the University of Edinburgh, and graduated M.B. Lond. in 1864 and M.D. and B.Sc. in 1865. He took great interest in the Young Men's Christian Association, and was the moving spirit of the Western Counties division of that organization, to whose funds he generously contributed. For twenty-five years he was a director of the Devon and Cornwall Banking Company, now amalgamated with Lloyd's Bank. He was consulting physician to the Devon and Cornwall Ear and Throat Hospital and to the Plymouth Public Dispensary. Besides building a convalescent home, he established a deaf and dumb institute, and defrayed the cost of erecting a crypt at St. Augustine's Church. He was a member of the Plymouth Division of the British Medical Association.

The sudden death of Dr. WM. MOIR of Darwen is recorded. He graduated M.B. C.M. Aberd. in 1892, and M.D. in 1897, took the D.P.H. Camb. in 1903, the B.Sc. (Public Health) Victoria University in 1908, and became barrister-at-law, Gray's Inn, in 1913. Before going to Darwen to succeed the late Dr. Armitage in practice he was medical superintendent of the Dunston Lodge Asylum, Gateshead-on-Tyne. He was one of the regional medical officers of the Ministry of Health under the National Health Insurance Acts for the North-Eastern Division of England. He was an ex-president of the Blackburn Division of the British Medical Association, and a member of the Society of Medical Officers of Health. He is survived by his widow and two children.

The Services.

R.A.M.C. AUXILIARY FUNDS.

THE annual meeting of the subscribers to the Auxiliary Royal Army Medical Corps Funds will be held at 11, Chandos Street, W.1, on Friday, April 29th, at 4 p.m.

HONOURS.

FOREIGN DECORATIONS.

THE President of the French Republic has conferred the Cross of Chevalier of the Legion of Honour upon the following in recognition of their services to the French sick and wounded at Hôpital Bénévole, No. 115 bis, at Villeneuve-sur-Lot during the late war: Dr. W. R. Dakin, Dr. F. M. Graham and Dr. A. Kirkpatrick Henry.

DEATHS IN THE SERVICES.

SURGEON-COLONEL GEORGE CUMBERLAND ROSS, Bengal Medical Service (retired), died at Milan on February 21st, aged 78. He was born on December 21st, 1842. The eldest son of the late Dr. Charles Amilius Ross, of Castleconner, co. Kilkenny, he was educated in Dublin, taking the L.R.C.S.I. in 1864, and the L.R.Q.C.P. in 1865. He entered the I.M.S. as assistant surgeon on October 1st, 1865, became full colonel on January 1st, 1894, and retired on October 1st, 1897. Most of his service was spent in civil employ in the Punjab, where he was for many years civil surgeon of the important stations of Delhi and Rawal Pindi in succession. On reaching the administrative grade, he filled the post of inspector-general of civil hospitals in the Central Provinces for a year, and afterwards the same post in Bengal. His son, Staff Surgeon G. C. C. Ross, R.N., lost his life early in the war in H.M.S. *Hawk* torpedoed in the North-Sea on October 15th, 1914.

Brigade-Surgeon John Trehaue May Symons, R.A.M.C. (retired), died at Cheltenham on March 11th, aged 87. He was born at Tintagel, Cornwall, on September 1st, 1833, took the L.F.P.S.G., the L.S.A. and the M.D. of Giessen University in 1855, and entered the army as assistant surgeon on December 8th, 1857, more than sixty years ago. In the regimental days he served in the Royal Artillery. He attained the rank of brigade-surgeon in 1883, and retired on September 1st, 1888.

Colonel C. H. Melville, C.M.G., A.M.S. (ret.), will give a lecture on "Some Lessons of the War," at the Royal Sanitary Institute, 90, Buckingham Palace Road, S.W.1, on Wednesday, April 27th, at 5.30 p.m. The chair will be taken by the Earl of Plymouth.

Medical News.

THE Royal Institute of Public Health will hold a series of conferences in London at the end of the first week in June. On Thursday, June 2nd, there will be discussions in the morning on municipal hygiene and its suggested connexion with the administration of the Poor Law and the future of voluntary hospitals, and in the afternoon on the housing problem. On Friday morning there will be a discussion on the prevention of ill health in industry, and in the afternoon on venereal diseases and the additional measures necessary for their prevention; on Saturday morning the discussion will be on the present machinery for dealing with tuberculosis. Further particulars can be obtained from the honorary secretaries, 37, Russell Square, London, W.C.1.

SIR LEONARD ROGERS has been appointed extra physician for clinical research and lecturer, and Lieut.-Colonel W. Clemesha lecturer on hygiene of the tropics, at the Hospital for Tropical Diseases and the London School of Tropical Medicine.

A THREE months' course of lectures and demonstrations in hospital administration for the diploma in public health is being given at the Western Hospital, Seagrave Road, Fulham, by Dr. R. M. Bruce, medical superintendent, on Tuesdays and Fridays, at 5 p.m. Applications should be made to the Clerk to the Metropolitan Asylums Board, Embankment, E.C.4, giving full name and address.

ON the recommendation of the Minister of Health, the King has been pleased to appoint Miss Ruth Darwin to be a Commissioner (unpaid) of the Board of Control.

THE inaugural meeting of the Institute of Physics will take place on Wednesday, April 27th, at 6 p.m., in the hall of the Institution of Civil Engineers, Great George Street, Westminster. Sir Richard Glazebrook, K.C.B., President, will preside, and Sir J. J. Thomson, O.M., will deliver an address. Mr. A. J. Balfour is expected to be present and extend a welcome to the institute. Non-members of the institute or of the societies associated with it may obtain tickets of admission on application to the Secretary, 10, Essex Street, Strand, W.C.2.

A COURSE of ten lectures on ante-natal and post natal child physiology will be given by Dr. W. M. Feldman, in the physiological theatre of the London Hospital Medical College, on Mondays, at 5 p.m., beginning on April 25th, and Dr. Millais Culpin will deliver a course of fourteen lectures on psychoneuroses in the clinical theatre of the hospital on Tuesdays and Fridays, at 5.15 p.m., commencing on May 3rd. Further particulars can be obtained on application to the dean of the college.

A POST-GRADUATE course of lectures and demonstrations will begin at the National Hospital for the Paralyzed and Epileptic, Queen Square, on May 2nd, and will be continued on each Monday, Tuesday, Thursday, and Friday till June 24th. Mr. Leslie Paton will give a series of six lectures and demonstrations in neurological ophthalmia, beginning on May 11th, and Dr. Greenfield a course in pathology if sufficient entries are received. Mr. Armour and Mr. Sargent will operate on Tuesday and Friday mornings, or at such other times as may be announced. The fee for the post-graduate course is seven guineas; for the course in ophthalmology, if taken with it, two guineas, and for the course in pathology three guineas. The Fellowship of Medicine's ticket will not admit to these courses.

THE Leicester Medical Society has arranged a course of post-graduate lectures to be given at the Royal Infirmary, Leicester, at 4.45, on Wednesdays, from April 20th to May 18th. Dr. Arthur Hurst will lecture on gastric and intestinal diseases on April 18th and May 4th, Dr. G. F. Still on urinary disorders in childhood and on dietetic causes of disease in infancy and childhood on May 11th and 18th, and Mr. R. C. Elmslie on manipulative surgery on April 27th.

AT a meeting of the Executive Council of the Federation of Medical and Allied Societies on April 5th it was announced that its incorporation had been satisfactorily completed. Sir Berkeley Moynihan, K.C.M.G., C.B., M.S., of Leeds, was elected president, and Sir Malcolm Morris, K.C.V.O., F.R.C.S.E., the Chairman of Council, was elected vice-president. The Federation now has (1) a medical council, (2) a council of allied professions, and (3) a citizens council. Each society is to have a representative on the council appropriate to its professional interests. The British Association of Radiology and Physiotherapy was elected to membership.

DR. DAN MCKENZIE has been elected a Corresponding Fellow of the American Laryngological Association.

A MEETING of the Röntgen Society will be held on Thursday, April 21st, at 8.15 p.m., in the Physics Lecture Theatre, University College, Gower Street, when a paper on a new form of stereo-fluoroscope will be read by Professor A. M. Tyndall and Mr. E. G. Hill, and descriptions and demonstrations will be given of new apparatus. A meeting of the Society is to be held at Manchester on May 6th, when Professor W. L. Bragg will read a paper and Professor A. V. Hill will demonstrate some physiological experiments.

DR. E. RIST has arranged a ten days' advanced course on tuberculosis in Paris for the latter part of May; the subjects to be treated will include artificial pneumothorax, experimental reinfection, the extent to which x-ray work has affected ideas regarding the pathology and diagnosis of lung tubercle, etc. One day will be spent at the hospital for surgical tuberculosis at Berck-sur-Mer, and a visit has been arranged to Bligny Sanatorium; visits will be paid also to the Rockefeller Dispensaries, Pasteur Institute, Laënnec Hospital, and other institutions. Further particulars can be had from Dr. W. H. Dickinson, 91, New Bridge Street, Newcastle-upon-Tyne.

ACCORDING to a recent census, the total population of Russia has been reduced by about 10 per cent. The diminution amounts to 45 per cent. in Moscow and 71 per cent. in Petrograd, and is very pronounced in all the cities. In the country districts, on the other hand, it is very slight.

THE King's Fund Policy Committee has just issued an interim report, dated April 4th, 1921, on the policy to be recommended for the preservation of the voluntary system of hospital management and control. Copies of this interim report and of the thirteen resolutions passed by the President and General Council on January 26th last may be obtained from King Edward's Hospital Fund for London, 7, Walbrook, E.C.4.

Letters, Notes, and Answers.

As, owing to printing difficulties, the JOURNAL must be sent to press earlier than hitherto, it is essential that communications intended for the current issue should be received by the first post on Tuesday, and lengthy documents on Monday.

ORIGINAL ARTICLES and LETTERS forwarded for publication are understood to be offered to the BRITISH MEDICAL JOURNAL alone unless the contrary be stated.

CORRESPONDENTS who wish notice to be taken of their communications should authenticate them with their names—of course not necessarily for publication.

AUTHORS desiring reprints of their articles published in the BRITISH MEDICAL JOURNAL are requested to communicate with the Office, 429, Strand, W.C.2, on receipt of proof.

In order to avoid delay, it is particularly requested that ALL letters on the editorial business of the JOURNAL be addressed to the Editor at the Office of the JOURNAL.

The postal address of the BRITISH MEDICAL ASSOCIATION and BRITISH MEDICAL JOURNAL is 429, Strand, London, W.C.2. The telegraphic addresses are:

1. EDITOR OF THE BRITISH MEDICAL JOURNAL, *Aitology, Westminster, London*; telephone, 2630, Gerrard.
2. FINANCIAL SECRETARY AND BUSINESS MANAGER (Advertisements, etc.), *Articulate, Westminster, London*; telephone, 2630, Gerrard.
3. MEDICAL SECRETARY, *Malisecra, Westminster, London*; telephone, 2630, Gerrard. The address of the Irish Office of the British Medical Association is 16, South Frederick Street, Dublin (telegrams: *Bacillus, Dublin*; telephone, 4737, Dublin), and of the Scottish Office, 6, Rutland Square, Edinburgh (telegrams: *Associate, Edinburgh*; telephone, 4361, Central).

QUERIES AND ANSWERS.

"W. A. R." who is treating a woman of 55 suffering from severe rheumatoid arthritis of one knee, believes that if the joint could be fixed she could get about without pain. Would fixation in plaster, he asks, be of any use in producing ankylosis, or is excision of the joint ever justifiable in such a case? No other joint is affected.

INCOME TAX.

"T. M. C." asks for further advice as to liability in respect of cash coming to him 3 months after he has sold his share in the practice. His previous answer was published on March 5th, 1921.

We are clearly of opinion that he is not liable, and suggest that the inspector of taxes, whose letter he has forwarded, does not appreciate the point. Simply stated, this is that when "T. M. C." ceases to do professional work his income ceases also; what he receives is in respect of past earnings, and he has paid tax on those earnings. Of course, not specifically on those receipts, but on other receipts which

were taken as equivalent thereto. The revenue authorities refuse to assess a commencing practice—or incoming practitioner—on the basis of cash receipts, holding, reasonably enough, that in the early years these do not provide a sufficient index to the earnings of the practice. The obvious corollary to that proposition is that cash received when the earning has ceased represents the recovery of fees which have already paid tax.

"J. J. M." is an assistant medical officer at an asylum receiving a salary plus emoluments, "not negotiable for cash," valued at £120. He inquires whether he is liable to pay tax thereon.

* No; the case is covered by a decision of the House of Lords in *Smith v. Tennant*.

LETTERS, NOTES, ETC.

DR. FREDERIC VICARS writes: Apropos of your interesting article on Alexis Soyer, the celebrated chef, the following note is worth recording: Though his wife was a person of violent temper and gave him many a *mauvais quart d'heure*, Soyer was devoted to her. On meeting a celebrated member of the Reform Club just after her death, the disconsolate Soyer asked him to suggest an epitaph for her tombstone. "Soyer tranquil," was the prompt reply.

MILK REGULATIONS.

REGULATIONS recently issued by the Food Controller and the Minister of Health continue in force the provisions which are already contained in the Orders of the Food Controller regarding the control of the quality of milk. Licences for the sale of Grade A and Grade A (Certified) milk will in future be issued by the Ministry of Health instead of by the Food Controller, and local authorities will be able to take steps to prevent milk being sold in any area under any of these designations, or "milk" which has been made up from dried milk or condensed milk, without such a licence. Similarly, no milk or cream to which any colouring matter or water has been added must be offered for sale. The licensing of wholesale dealers in milk and the registration of retail dealers will be continued for the present by the Board of Trade as the successor of the Food Controller.

EMETINE IN BILHARZIASIS.

"B. H." writes: Dr. Harkness, in the *BRITISH MEDICAL JOURNAL* of December 11th, 1920, page 890, writes on the superiority of sodium antimonium tartrate over emetine in the treatment of bilharziasis, mentioning that he was taking, or being given, emetine gr. $\frac{1}{2}$, and that no improvement was noticed. The doses, however, advocated from Egypt have been gr. $\frac{1}{2}$ every third day or so, and the smallness of Dr. Harkness's dose will no doubt account for the apparent failure. In my own hands emetine doses of gr. $\frac{1}{2}$ every third day has given the best pleasing results; and usually only four have been required—anaemia, urine and general debility quickly clearing up. The immediate after-effects of such a large dose of emetine is sometimes a feeling of nausea and even vomiting, but usually no discomfort is felt in adults; a child of 10 years will easily stand gr. 2 $\frac{1}{2}$. These remarks are not meant to advocate the use of emetine in place of antimony, which latter has proved its worth in bilharziasis. Certainly one great virtue in emetine is the simplicity of administration—intramuscular into the deltoid and lumbar region.

THE TREATMENT OF PNEUMONIA.

WE have received from Dr. R. W. Burkitt, F.R.C.S.I. (Nairobi), a communication in the course of which he says: For some years past I have treated acute pneumonic fever on the following general principles, and I have now successfully treated 250 cases in this way, chiefly Europeans, but including Asiatics and a few natives of Africa. I have not only never lost one who came under treatment early, but, provided I saw my patient within the first twenty-four hours of his fever, I have had no anxiety as to his recovery. I should not advise anyone to adopt the method of treatment unless he means to be thorough—half measures are of little value. Briefly, my principles of treatment are in this order: (1) The temperature is kept under 101°; (2) severe purgation is employed during the first twelve to twenty-four hours, afterwards a daily motion; (3) acidosis is avoided by giving potassium citrate; (4) enormous quantities of water are drunk; (5) absolutely no nourishment of any kind whatever is allowed until the fever is over, the tongue clean, and the patient hungry; (6) no stimulants of any kind are allowed. The keeping of the temperature under control, in this country where we have a big evaporation, is effected by the patient being at once put on a waterproof sheet, absolutely naked except his feet, the whole body being kept continuously wet and placed in a draught so as to get the maximum evaporation. The feet are kept warm with socks and a hot bottle; this makes the patient comparatively comfortable. Patients only complain of the treatment at first; in a few hours they get to see the value of it. There must be no half measures here—thoroughness always saves life. When the temperature is 100° the patient is allowed a sheet, as it tends to make him sleep, but if his temperature goes up much it is taken away. Sometimes with a sheet the temperature may run up 1° to 2°. When it goes below 100° he is allowed further clothing, but he is

treated according to the temperature at the time. As to purging, there must be degrees of severity according to the illbloodedness of the patient and the amount of toxæmia present. In a fullblooded toxæmic person, near the beginning, I help the purging by at once bleeding to the extent of a pint or so. This gives immediate relief to the right heart and to the whole system in a lessening of toxins. If done late bleeding does harm, the reason probably being that the antitoxins then made are bled out. In a case not seen until late on, heavily intoxicated and blue, I think the best thing is to purge severely, but not to bleed. I purge with calomel and Epsom salts for the first twelve to twenty-four hours only, and afterwards I secure a liquid motion daily with a light saline.

Acidosis is common in pneumonia, and, therefore, all my patients receive a teaspoonful of potassium citrate three times a day, although some require far more. It is impressed on every patient that his life depends on the amount of cold water he drinks; he is kept frequently urinating. I have found that the giving of any food during any fever (even a little diluted milk) is definitely prejudicial until the fever is finished, the tongue clean, and he is hungry. I have kept a fever patient as long as six weeks on pure water with none but the happiest results.

CLIMATE OF THE RIVIERA.

DR. JULIAN TAPLIN writes with reference to two topics touching the climate of the Riviera. He has been residing at Saint Raphael, on the main boulevard, and complains that, though it is the main route to the Eastern Riviera, the road is not kept cleansed and watered, so that there is a great deal of dust. The other point is that he desires to hear of some place within easy reach of the Riviera, which would be suitable for a case of chronic pulmonary tuberculosis during the summer.

THE RUPEE EXCHANGE.

"HAKIM" writes: The rupee, which was worth two shillings and elevenpence a year ago, is worth only one shilling and threepence to-day, and its value is falling steadily. No prospects of granting of exchange compensation are held out, and twenty rupees may soon be equivalent to one pound sterling. Passages to and from India are all quoted in sterling, and as the rupee falls in value so does the cost of passages in rupees rise. A second class return passage from India now costs just over two thousand rupees. It is possible for a bachelor to save enough from his salary to pay for his return passage, but it will use up all his savings. With the rupee at sixteen to the pound and likely to go to twenty, any man who contemplates matrimony must reconcile himself to perpetual exile.

AN ELECTRIC THERMOSTAT.

THE Wild-Barfield electric thermostat appears to be constructed on a new plan; a capsule filled with a volatile fluid is made, by its expansion, to switch off a part of the heating element as soon as the full temperature is reached. Afterwards the full current is switched on and off intermittently, so that a temperature is maintained steadily at the desired height. The device, which can be set for temperatures up to 400° F., is made by Automatic and Electric Furnaces, Ltd., 281, Gray's Inn Road, W.C.1.

VACANCIES.

NOTIFICATIONS of offices vacant in universities, medical colleges, and of vacant resident and other appointments at hospitals, will be found at pages 31, 34, 35, 36, 37, and 38 of our advertisement columns, and advertisements as to partnerships, assistantships, and locum tenencies at pages 32 and 33.

THE appointment of certifying factory surgeon at Burton-upon-Trent (Stafford) is vacant.

"CAPT. R.A.M.C." has omitted to enclose his name and address.

REDUCTIONS of approximately 20 per cent. in the price of motor covers and of 15 per cent. in that of inner tubes are announced by the Stepney Company.

SCALE OF CHARGES FOR ADVERTISEMENTS IN THE BRITISH MEDICAL JOURNAL.

	£	s.	d.
Six lines and under	0 9 0
Each additional line...	0 1 6
Whole single column (three columns to page)	7	10	0
Half single column	3 15 0
Half page	10 0 0
Whole page	20 0 0

An average line contains six words.

All remittances by Post Office Orders must be made payable to the British Medical Association at the General Post Office, London. No responsibility will be accepted for any such remittance not so safeguarded.

Advertisements should be delivered, addressed to the Manager, 429, Strand, London, not later than the first post on Tuesday morning; preceding publication, and, if not paid for at the time, should be accompanied by a reference.

NOTE.—It is against the rules of the Post Office to receive *posts restante* letters addressed either in initials or numbers.

Remarks

ON

POSTURAL OR SO-CALLED STATIC
DEFORMITIES.

BY

A. S. BLUNDELL BANKART, M.Ch.CANTAB.,
F.R.C.S. Eng.ORTHOPAEDIC SURGEON, MIDDLESEX HOSPITAL; SURGEON, ROYAL
NATIONAL ORTHOPAEDIC HOSPITAL AND HOSPITAL FOR EPILEPSY
AND PARALYSIS, MAIDA VALL.

I.

Static deformities have been defined as those which are due in the main to the action of gravity. But, as everyone is subject to the action of gravity, it is clear that this is not enough in itself to account for deformity in an otherwise normal person. It would be more correct to say that static deformities are due to default of the normal mechanism for counteracting the influence of gravity and maintaining the body in the upright position. This mechanism is a nervous mechanism, for it has been shown by Sherrington¹ that the upright attitude or posture of the body is maintained by continuous reflex muscular activity (postural activity). For this reason I prefer to speak of these deformities as postural rather than static. The word static implies something almost wholly mechanical, whereas I believe that many of these deformities are really nervous in origin.

I must say, however, that by postural deformity is meant not merely a faulty posture as such, but also the deformity that may develop from it. This is important, because many writers have tried to draw a distinction between postural deformity and structural deformity, holding that a deformity is no longer postural when structural changes have taken place in it. Such a distinction is wholly artificial and misleading. A rachitic deformity is still a rachitic deformity after the active rickets has subsided. A paralytic deformity is a paralytic deformity even though the paralysis has recovered. Similarly, a postural deformity is one that begins as a faulty posture and passes through all degrees up to severe structural alteration.

GENERAL CONSIDERATIONS.

In the skeletal muscles we meet with two kinds of muscular activity. The one is phasic—quick and transitory and concerned with the execution of movement; the other is tonic—relatively slow and prolonged and concerned with the maintenance of posture. These two kinds of activity are quite distinct. Indeed, in certain invertebrates there are separate muscles, differing in structure and in appearance, for the execution of movement and for the maintenance of posture respectively. In vertebrates the same muscle is utilized for both purposes, but there is reason to believe that different parts of the muscle fibres are concerned in these two functions. It has been suggested by Bottazzi² and others that the sarcostyles constitute the contractile or movement mechanism, and the sarcoplasm the tonic or posture mechanism. Further, there is some evidence that these two mechanisms have independent nerve supplies, and that the sympathetic may be concerned in the tonic or postural contraction of voluntary muscle. Perroncito³ and Boeke⁴ have described accessory (sympathetic) nerve endings in voluntary muscles. These consist of fine non-medullated nerve fibres connected with the perivascular sympathetic nerve plexus and terminating in the sarcoplasm independently of the motor end plate. De Boer⁵ was able to abolish the tonic or postural contraction in the hind limbs of the frog and cat by section of the rami communicantes of the sympathetic.

This question is not yet settled, but it is particularly interesting in view of the close similarity between postural contraction in skeletal muscle and contraction in the smooth unstriated muscle of the hollow viscera and blood vessels. Indeed, Sherrington maintains that postural activity is the mechanism whereby these hollow viscera (stomach, bladder, etc.) and blood vessels normally adapt themselves to variations in the volume of their contents.

In the skeletal system postural activity occurs only in the antigravity muscles—that is, those which constantly resist and counteract the influence of gravity. This does not mean that no other muscles under any circumstances are capable of acting posturally, but that the normal postural or standing reflex involves contraction of the antigravity muscles only, their antagonists being inhibited.

Sherrington pointed out that the failure of many of the earlier experimenters to demonstrate tonus in skeletal muscle was due to their failure to appreciate this fact. Many of the observations were made on the gastrocnemius of the frog, which is an extensor muscle. But the habitual posture of the frog is squatting, not standing, and in this attitude the hind limbs are held in nearly full flexion. Accordingly, reflex postural activity is found in the flexor muscles of the hind limbs of the frog, and not in the extensors. In Broudegeest's classical experiment demonstrating reflex tonus in the hind limbs of the frog it was the flexor muscles which exhibited the tonus. On the other hand, in the cat, dog, and monkey (and man), it is the extensors which exhibit the tonic or postural activity.

Postural activity in man is essentially a continuous act of extension—extension of the head and neck, the spine, the hips, and the knees—with adduction and inversion of the feet.

The chief characteristics of postural activity as summarized by Sherrington are: (1) the low degree of tension it usually develops; (2) the long periods for which it can be maintained without fatigue; (3) the difficulty of obtaining by artificial—for example, electrical stimulation reflex contraction at all closely resembling the postural contraction produced by natural stimuli; (4) the relative ease with which reflex inhibition interrupts the postural contraction; and (5) and (6) the "lengthening" and "shortening" reactions obtainable from muscles exhibiting postural contraction.

The tension developed is usually quite mild, but it may be considerable. Usually it is just enough to maintain ordinary postures, and when greater tension than that is required it is obtained by the same kind of contraction as that employed for movements. But this latter kind of contraction cannot be long maintained owing to fatigue.

A remarkable feature of postural activity is its insusceptibility to fatigue. It is well known that phasic or voluntary muscular contraction cannot be maintained for long owing to fatigue. But postural activity can be maintained for long periods—hours or even days—without appreciable signs of fatigue. It has been shown that the energy-cost of a posturally acting muscle is extraordinarily low as compared with voluntary contraction. Indeed, the contrast is so striking as to suggest that these two forms of muscular activity are fundamentally different.

But perhaps the most characteristic feature of postural activity is what Sherrington⁶ has called the "lengthening" and the "shortening" reactions. By this is meant the property which a postural muscle has of adapting itself to different lengths without change of tension. The lengthening and shortening reactions are best seen in cases of decerebrate rigidity, in which postural activity is free from the control of the higher centres. For example, if the extended knee be passively flexed, the limb remains fixed in the position to which it was moved. By this movement the quadriceps muscles, of course, are lengthened. But there is no increase of tension in the muscle. For, if the tension is measured by the weight which the muscle will just counteract, it is found that the weight is exactly the same whether the muscle is in the longer or the shorter state. In other words, the quadriceps adapts itself to and maintains the increased length with exactly the same tension that it possessed before it was lengthened. Similarly, when the flexed knee is extended the quadriceps adapts itself to the shorter length without change of tension. And in whatever way changes of posture are brought about—whether passively or by reflex or by voluntary muscular actions—these lengthening and shortening reactions are appended to the phasic contractions, so that different postures are maintained with the minimum expenditure of energy.

The afferent impulses which give rise to the postural reflex originate in the posturally acting muscles themselves—that is, it is a proprioceptive reflex, and the principal nerve centres concerned are situated in the paracerebellar nuclei. The higher parts of the brain, though not essential to the crude postural reflex, yet normally

exert a reinforcing and modifying influence upon it. In this way posture is influenced by the labyrinths, the cerebellum and the cortex cerebri.

Postural activity is acquired in early life. A newborn child cannot hold up its head, still less can it support its body in the upright position. This is not because the muscles are too weak, but because the nervous mechanism for these actions is not yet developed. In due course, by constantly repeated voluntary effort, the child learns to hold up its head, then to sit, to stand, and finally to walk. The upright attitude thus acquired laboriously by voluntary effort, then becomes habitual and subconscious, and is maintained by reflex tonic muscular activity (postural activity).

When the child begins to stand, the feet are flattened and everted by the body weight; this, again, is not because the muscles are weak, but because postural activity is not yet fully developed. When the child learns to walk, postural activity becomes established, and the feet are adducted and inverted—that is, the tendency to passive abduction and eversion is from that time onwards constantly resisted by reflex tonic muscular activity (postural activity).

Postural activity, then, being the normal mechanism by which the upright position of the body (including the normal attitude of the feet) is maintained, it is to postural activity and its modifications that we should first turn for an explanation when we meet with abnormal departures from the upright position.

SCOLIOSIS.

One of the commonest "static" deformities is scoliosis or lateral curvature of the spine, and gravity is, no doubt, an important factor in its development. The influence of gravity on an initial curve of the spine is to tend to increase it and to bring about those rotatory changes in the vertebrae which are so characteristic a feature of the established deformity.

But gravity by itself is responsible for scoliosis to a limited extent only. In its purest form gravity scoliosis is seen in those cases which arise directly as the result of some occupation, such as carrying heavy weights on one shoulder. In such cases a moderate amount of scoliosis may develop very slowly in the course of years. It is a true adaptation deformity. It cannot be corrected, and it shows little tendency to increase spontaneously.

When the bones are softened by disease the force of gravity may produce severe deformity, as is seen in rachitic scoliosis, though it may be noted that in rickets loss of tone is as marked a feature as bone softening. Again, when the spinal muscles are paralysed, gravity produces deformity, but in this case for a long time the structural changes are slight compared with the extent of the curvature. It is true that severe fixed deformity often occurs in paralytic cases, but, if such a case is compared with a case of postural scoliosis of the same degree, it is remarkable how flexible the paralytic deformity remains, and to what an extent it can be corrected, at least for a very considerable time.

The commonest variety of scoliosis—namely, postural scoliosis—differs in origin, course and development from all these other varieties. It is essentially a progressive deformity, and its progress is often rapid and out of all proportion to the mechanical factors involved.

It has been customary to include in the etiology of this deformity all sorts of conditions which may cause more or less constant curves in the spine. Thus, scoliosis has been attributed to faulty attitudes assumed by children at school, to inequality in the length of the lower extremities, to weak muscles, etc. But nearly every child sits with a crooked back when writing at a desk or table, yet few develop scoliosis. Boys sit just as badly as girls—or worse, yet scoliosis is far less common in boys than in girls. Inequality in the length of the lower extremities is much more common without scoliosis than with it. We all know many cases of short leg from one cause or another, in which there is a constant curve in the spine on standing, but they have not developed scoliosis. Some such cases, it is true, develop a certain amount of curvature which hardly alters at all in the course of many years. It is an adaptation deformity and quite different from the ordinary postural scoliosis.

General debility and muscular weakness is so common apart from scoliosis that it cannot alone be considered as a

cause of the deformity. In cases of actual paralysis of the spinal muscles—which may be taken as the extreme of muscular weakness—the deformity is almost entirely mechanical, and it differs in many ways from postural scoliosis. There is no greater mistake than to suppose that scoliosis is a deformity of weedy girls who are not strong enough to hold themselves up. Most of the cases seen in practice are of quite average muscular development.

It has been said that the ultimate cause of scoliosis is "spinal insufficiency"—one of those clever-sounding phrases which seem to mean a great deal, but which really mean nothing at all. Those who use the expression say that spinal insufficiency is a want of proportion between the weight which the spine has to carry and the "resistance" or carrying power of the spine. They do not say what the resistance is, nor in what way it is "insufficient."

Now, we have seen that the upright position of the body is maintained by continuous reflex muscular activity; that this postural activity is of a special kind, capable of being sustained for long periods without fatigue; and that it is controlled by a special nervous mechanism of its own. A faulty posture therefore suggests, in the first place, a faulty nervous mechanism or an abnormal nervous influence brought to bear upon that mechanism.

It has been mentioned that the labyrinths normally influence postural activity. The natural stimulation of the labyrinths arises from their position in space, and it has been shown experimentally by Magnus and de Kleijn⁷ that postural activity is influenced reflexly by the position in which the head is held. When the head is bent forwards postural activity is inhibited, not only in the extensor muscles of the head and neck, but throughout the length of the spine and in the lower extremities. Conversely, when the head is extended, postural activity is increased. In lateral flexion there is a corresponding adjustment of postural activity on the two sides.

These observations forcibly recall certain attitudes frequently associated with deformities, as, for example, the bent head familiar in cases of adenoids, myopia, neurasthenia, paralysis agitans, old age, and other conditions which are often accompanied by kyphosis. When the head is held erect the spine is usually straight and the lumbar lordosis well developed. Lateral flexion of the head may, I think, find a place in the etiology of scoliosis, either as a contributory causative factor or as determining the localization of the principal curvature.

The cerebral cortex exerts a modifying influence on postural activity, either directly or through the medium of the cerebellum. The hypotonia of cerebellar deficiency and the characteristic posture assumed in some cases of cerebellar disease are familiar to neurologists. It is an everyday observation that, other things being equal, the upright figure and the bent figure reflect two very different types of *mind*. The difference between the attitude of a street loafer and that of a trained soldier is not merely physical—it is far more mental. In the "setting up" of a raw recruit discipline, drilling, and so-called physical exercises, produce a mental change. By their means a habit is formed, at first conscious and with effort, but finally subconscious and ingrained.

These are variations of posture within normal limits. But I would put forward the view that abnormal postures also are primarily nervous or mental in origin—that postural scoliosis, in fact, originates as a functional nervous disorder. Mental fatigue or inertia—in fact, neurasthenia—leads to deficient postural activity, even though the muscles are well developed and voluntary muscular power is unimpaired. When postural activity is deficient the erect posture is imperfectly maintained, and under the influence of gravity the spine or part of it becomes curved. At first the spine can be straightened by voluntary effort, but, as we have seen, this form of activity cannot be sustained on account of fatigue. Postural activity is essential for sustained muscular action.

The dissociation of phasic and tonic or postural muscular activity is seen in an aggravated form in certain nervous diseases, as, for example, in myasthenia gravis. In this condition the patient is able to perform a voluntary movement, but the tonic or postural activity is absent from the affected muscles, so that the attitude assumed by the voluntary contraction cannot be sustained. Thus, the patient can raise the eyelids voluntarily, but cannot keep

them raised. The muscles voluntarily contracted rapidly tire, and the movement can only be repeated after an interval for their recovery. Normally, a postural contraction would be appended to the voluntary contraction, and the patient would be able to keep the eyes open without effort or fatigue.

The same phenomenon can be demonstrated by electrical (faradic) stimulation of the muscles, and gives rise to a characteristic reaction—the myasthenic reaction. If the muscle is stimulated repeatedly at short intervals with the faradic current, it gives at first a brisk response, but the succeeding contractions become weaker and weaker until at last no response is obtained with the strongest current. Or, if the faradic current is applied continuously, the muscle at first gives a brisk contraction which gradually fades away and disappears, although the current is still passing. After a short interval the muscle recovers its excitability, which, however, again disappears on repeated or continuous faradic stimulation. The galvanic reactions of the muscles are not affected.

I have found the myasthenic reaction to be present in cases of postural scoliosis. Naturally, one would not expect it to be so well marked as it is in myasthenia gravis, though in that condition it is, as a matter of fact, variable. But it has been demonstrable in many cases which I have examined for it, and I think it clearly indicates that deficient postural activity, and not muscular weakness, is the immediate underlying cause of postural scoliosis.

The frequent association of scoliosis with neurasthenia, and with a neuropathic family history, was noted twenty years ago by Oppenheim,⁶ and I have frequently noted the same among my own patients. Again and again I have seen scoliosis coming on apparently without cause in girls who were perfectly well developed, who went to good schools, and who lived apparently in the best conditions. Sometimes in such cases one would obtain a history of overwork—particularly, working for an examination. Sometimes a neurotic tendency or peculiar temperament would be noted in the patient herself. But most common of all, I think, is a history of neurosis of some sort or other in the parents or their immediate relatives. I have convinced myself that the mental condition is of the greatest significance in these patients—often far more so than the physical aspect of the deformity.

But while the functional origin of scoliosis may thus be accounted for, the development of the deformity requires further consideration. Gravity, no doubt, plays a part, but, as I have already said, the progress and fixation of postural scoliosis is often rapid and out of all proportion to the mechanical factors involved. The early fixation of a postural curvature is due to contracture of the soft parts in relation to the vertebrae, and I would suggest that this, in the first place, is of the nature of a functional contracture.

Some light may be thrown on the question of functional contracture by considering the occurrence of contracture in paralysed muscles and in their non-paralysed antagonists respectively. Structural fixation, as has been said, occurs slowly in paralytic as compared with postural scoliosis, and this is in accord with our experience of paralytic and non-paralytic contractures generally. In a case of drop-foot, when all the muscles of the leg are paralysed, shortening of the calf muscles occurs slowly, and for some time after it has begun it can easily be corrected by simply stretching the contracted muscles. But, in a case of drop-foot in which only the dorsiflexor muscles are paralysed, contracture occurs with great rapidity if the foot is not supported, and it firmly resists correction by mechanical means.

The two processes are quite distinct. Contracture in a paralysed muscle is due to loss of elasticity consequent on fibrosis in the degenerating muscle. In the case of non-paralysed muscle, physiologists are generally agreed that lengthening is as much an active process as shortening or contraction. When a muscle has contracted in response to a nervous impulse it requires another nervous impulse to initiate the process of lengthening. The natural impulse for lengthening a muscle is the direct outcome of the impulse for causing contraction of its antagonist. Therefore a break in the arc of reciprocal innervation has a twofold effect. Not only is the paralysed muscle unable to receive impulses to make it contract, but its non-paralysed antagonist is unable to receive the impulses necessary to make it lengthen. The latter, therefore,

having once shortened, remains shortened, and very soon its power of elongation is permanently lost.

In postural scoliosis we have a condition in which postural activity is deficient. The spine is curved to one side, and the law of reciprocal innervation holds good for the erector spinae muscles on either side of the curvature. In order to straighten the spine, the muscles on the convex side must be made to shorten, while at the same time those on the concave side must be made to lengthen. In early cases this can be done to some extent by voluntary action, but, as we have seen, this is quite different from postural activity. The nervous impulses necessary to bring about postural readjustment are not forthcoming. The muscles on the concave side, therefore, remain shortened, and, just as in the case of the non-paralysed antagonists of paralysed muscles, their power of elongation is soon permanently lost. The analogy holds good except for the fact that in the paralytic case the faulty innervation is due to an organic lesion, whereas in postural scoliosis it is functional—that is to say, the brain is unable to initiate the process of postural readjustment.

I would suggest that progressive functional contracture on the concave side of the curvature is the cause of the rapid fixation which occurs in so many cases of postural scoliosis. One is tempted further to speculate whether the structural changes both in the soft parts and in the bones are in any way connected with the sympathetic innervation of these parts. During recent years we have become so familiar with physical effects of functional nervous disorders—for example, cold and blue limbs, congestion, sweating, oedema, atrophy, contracture, peri-articular fibrosis, etc.—effects which are nutritional and therefore under control of the sympathetic, that it is no longer justifiable to assume, as once was done, that because a change is structural, therefore it cannot be functional in origin. I shall, however, return to this question in the second part of this article.

TREATMENT OF SCOLIOSIS.

If the foregoing inferences are correct it is obvious that they must have an important bearing on the treatment of scoliosis. How often does one see scoliosis appraised and treated almost entirely from behind the patient's back? If you want to know whether a patient has got scoliosis, look at her back. If you want to know why she has got it, and how to treat it, look at her face. The face is said to be the mirror of the mind, and you will find there and in her neurological history information of at least equal importance to any that can be obtained from examination of the back.

The principal cause of deficient postural activity is mental fatigue or inertia. Temperament, environment, occupation, and the general state of health are important factors. The child who sits badly at school and develops scoliosis is the child not with weak muscles, but with the overtaxed brain. It may be remarked that this depends more on the mental capacity of the individual than on the actual amount of work done. A clever child may be tempted to compete with older children, while a dull child may be overworked in merely trying to reach an average or a low standard. In such cases it is useless merely to introduce a course of exercises into the ordinary school routine. Either the routine should be radically altered or the child should be taken away from school.

Patients with scoliosis can be divided roughly into three classes—(1) an active type, apparently active in mind and body, and generally well developed; (2) a listless apathetic type, disinclined for exertion, poorly developed or flabby, and lacking interest in her surroundings; and (3) an obstinate type—lazy, careless of appearances, and difficult to influence. Each of these requires different treatment. The active type requires rest or at least curtailment of excessive activity—usually mental; the apathetic type requires stimulation, persuasion and re-education; the obstinate type requires vigorous stimulation, discipline and work.

It need hardly be said that the patient's general condition should be treated. As in neurasthenia generally, change of environment and occupation is often the ideal, but is not often attainable. Anæmia, constipation, adenoids, etc., should be treated if necessary. Strychnine augments the postural reflex, and is the basis of most "tonics," so it may often be given with benefit.

With regard to so-called physical exercises, postural scoliosis is due, not to muscular weakness, but to deficiency of the habitual subconscious state of reflex activity which normally maintains the upright attitude. The object of treatment, therefore, is not to strengthen or develop particular muscles or groups of muscles, but to redevelop a habit—the postural reflex. This may be done now in the same way as originally in early childhood—namely, by voluntary muscular effort constantly repeated until it becomes involuntary, subconscious and habitual—in other words, by exercises.

Exercises are only one of the means to this end. They should be designed to correct faulty postures as such, and not with the idea of developing particular muscles. Intermittent exercises are of little use in themselves. The patient must be got to strive for a constant effect. Her co-operation is essential, and to this end the personality of her instructor is of far more importance than the particular exercises done.

Restoration of the postural reflex is the basis of all curative treatment of scoliosis. If a curvature is flexible, so that it can be straightened by active or passive movement, it will be kept straight when the postural reflex is re-established, and the patient will be cured.

A curvature that is partly fixed by structural changes can be corrected only so far as it can be made flexible. The flexibility of a structural curve can often be materially increased by active and passive corrective movements, but rarely, if ever, can a structural curve be made completely flexible and therefore curable by these means. A moderate amount of fixed residual curvature may be held in check indefinitely, if the postural reflex is re-established. Such a curve, however, tends slowly to increase mechanically under the influence of gravity; just as an occupational or adaptation curvature does, and many such cases eventually show a poor return for the time, labour, and money that has been expended on their active treatment. Therefore, if a curvature is not held in check by a reasonable amount of active treatment, it should be given mechanical support.

With regard to forcible correction and the application of plaster jackets in scoliosis, it is known that, apart from its effect on the distortion of the ribs, this method, like others, depends for its success upon flexibility of the spine. Most orthopaedic surgeons will agree with the finding of the Scoliosis Committee of the American Orthopaedic Association (1916) that no case of fixed scoliosis has yet been shown to have been corrected in the anatomical sense by any method. At best, forcible correction is but a preliminary measure, and if it is not followed by re-education of the postural reflex or by efficient mechanical support, it is both useless and harmful.

The day has passed when it was customary to hang a so-called spinal support on every crooked back. Nearly everyone now treats scoliosis by exercises, and I think that exercises are indicated in the majority of cases. But I would plead for discrimination in their use, as in that of any other therapeutic measure. Some people have made almost a fetish of exercises. One sees cases so treated, literally for years, without any appreciable benefit, and a spinal support is often ordered only as a last resort. Some cases are quite unsuitable for treatment by exercises from the beginning. Exercises in many cases are given without appreciation of their real purpose. They are only one of the means to an end—namely, restoration of the postural reflex, and to attain this end it is the patient, and not merely her spinal column, that requires treatment.

REFERENCES.

- ¹ *Brain*, 1915, vol. xxxviii, p. 191. ² *Journ. of Physiol.*, 1897, vol. xxi, p. 1. ³ *Arch. di Fisiologia*, 1904, vol. ii, p. 132. ⁴ *Anat. Anzeiger*, 1910, Bd. xxxv, S. 481. ⁵ *Acta Neurobiologica*, 1914, Bd. vii, S. 378 and 837. ⁶ *Quart. Journ. of Exp. Physiol.*, 1909, vol. ii, p. 109, and *Proc. Roy. Soc.*, 1908, B, vol. lxxx, p. 552. ⁷ *Pflüger's Archiv*, 1912, Bd. cxlv, S. 455 et seq. ⁸ *Deutsche Ärztesetzung*, 1900.

(To be continued.)

THE Department of Social Hygiene in the League of Red Cross Societies, whose headquarters are at Geneva, will in future be known as the Department for Combating Venereal Diseases. Mr. Walter Clarke has been appointed Chief of this Department and Lieut.-Colonel Ritchie, Assistant Chief. The League has published in English, French, German, Italian, and Spanish two pamphlets concerning the fight against venereal diseases, entitled respectively "The venereal diseases survey" and "Venereal diseases—a challenge to the Red Cross."

Olliver-Sharpey Lectures

ON
THE NATURE OF FLUTTER AND
FIBRILLATION OF THE
AURICLE.

BY

THOMAS LEWIS, M.D., F.R.C.P., F.R.S.,

PHYSICIAN OF THE STAFF OF THE MEDICAL RESEARCH COUNCIL;
PHYSICIAN TO UNIVERSITY COLLEGE HOSPITAL, LONDON; HONORARY
CONSULTING PHYSICIAN TO THE MINISTRY OF PENSIONS.

LECTURE II.—AURICULAR FIBRILLATION.*

IN the first of these lectures I have endeavoured to put before you the chief conclusions which we are able to form respecting that rather rare condition auricular flutter, and have stated that flutter as it occurs in man is due to a single wave circulating continuously. In this lecture I propose to deal with the much commoner and therefore more important disorder, auricular fibrillation. Now these two conditions are very closely related, as has been recognized for some years; they are known to be related, not only because of several resemblances, but because the one not infrequently passes into the other. Thus flutter of the auricle, as I pointed out some years ago, may usually be converted into fibrillation by the administration of heavy doses of digitalis; a conversion which is made use of in the present-day therapy of flutter. We shall see presently how the two states are related, and that circus movement underlies both. To explain the interrelation it is necessary for me to expand what I have already touched upon—namely, certain reactions of the auricular muscle to increased rate of beating. We must study in more detail the change which occurs in the length of the refractory period and in the rate at which the waves travel, as the rate of beating rises.

INFLUENCE OF HEART RATE ON THE REFRACTORY
PHASE, ETC.

The changes are somewhat complex, and may be illustrated most clearly by means of the accompanying diagram (Fig. 1). To the left of the diagram is a double-headed arrow, which represents the length of the auricular cycle when the heart is beating at a normal rate. This cycle is divisible into two parts, as indicated by the two double-headed arrows which stand just to the right of the first; it is divisible into the *refractory period*, during which the auricular muscle is in the excited or contracted state, and into the *responsive period*, during which the muscle is inactive or resting. I represent the refractory period in black and the responsive period in white, and the remainder of the diagram shows, on the basis of direct observation, how these two periods are proportioned to each other as the heart rate is raised. As the heart rate rises by equal increments—say from 100 to 150 to 200 to 250, etc.—so the length of the cycle shortens. If the lengths of the cycles, as these shorten, are charted vertically upon a horizontal base line (as in the figure), their ends join up to form a curve, the steepness of which gradually decreases. The curve of the end of the cycle approaches the base line, at first rapidly, but gradually less rapidly. The two lines will meet at infinity. The end of the refractory period also forms a curve which moves towards the base line (it is represented by the top edge of the black portion of the figure). Briefly, the refractory period of the muscle shortens as does the length of the contraction when the heart rate is raised. But the refractory period does not shorten to the same extent as does the length of the cycle; consequently the *responsive period* dwindles when the rate is advanced. It dwindles until, eventually and at a very high rate of beating, it disappears altogether. When this happens the muscle will not respond to every impulse reaching it; it breaks into what has been termed 2:1 (or half) response—that is to say, it responds only to alternate impulses entering it. That is but natural, seeing that only alternate impulses will fall during the responsive period of preceding cycles.

Now the precise manner in which this alternating response is foreshadowed in the mammalian auricle is

* Delivered before the Royal College of Physicians of London, April 14th, 1921.

peculiar, and considerably important, it is necessary thoroughly to understand it. As the rate of beating rises, and the period of responsiveness shortens, a time comes when the muscle develops what is spoken of as a *partially refractory period*. It is a phase of the cycle, during which the muscle as a whole may or may not respond to stimulation. When this partially refractory phase first develops the cycle seems to be divisible into three parts:

at the beginning is the absolutely refractory phase; this is succeeded by a partially refractory phase; a short phase remains at the very end of the cycle, during which the muscle is always responsive to stimulation. But the end of the partially refractory phase is not sharply defined: it fades imperceptibly into the phase of responsiveness. If you will, the matter may be expressed somewhat differently. During the early and greater part of the cycle the muscle is quite refractory, but the end of this phase is no longer clean cut and determinate; if at one instant the muscle is wholly refractory, at the next instant it is not wholly responsive; the refractoriness fades away gradually (through the partially refractory period) and responsiveness gradually develops. The state of refractoriness is found to be denser as it is traced backwards through the cycle until at last it becomes absolute. The development of the partially refractory phase, which is a phenomenon of high rates of beating, expedites the closure of the gap between the end of the absolute refractory period and the end of the cycle. The precise instant at which the state of partial refractoriness ends is not measurable, but it is certain that, as the rate of beating advances, it soon bridges the gap completely. When this stage is reached the cycle is divisible into two—namely, a phase of absolute refractoriness and a phase of partial refractoriness; there is no true or wholly responsive phase. This state of the muscle is represented in a small diagram above the main figure.

The meaning of the change which I have described is not obscure; it is this: when the rate is sufficiently raised, the muscle fibres do not all contract during each cycle, some contract in alternate cycles only, and the critical rate at which regular response fails is not the same for all the muscle fibres; some fail to respond earlier than do others. During the phase of absolute refractoriness all the fibres are refractory to stimulation, during the remainder of the cycle the fibres one after another recover their excitability, the muscle as a whole becomes more and more responsive therefore, but up to the very end of the cycle some fibres still remain refractory.

I have dealt with this question of partial refractoriness at some length because it is essential that it be comprehended fully and clearly. It is a phenomenon which has fundamental influences upon the action of the auricle beating at very advanced rates. What I especially desire to emphasize is that, at these advanced rates of beating, each excitation wave entering the muscle finds that muscle imperfectly recovered from the passage of its predecessor.

Let us apply the small diagram in the upper part of Fig. I to our picture of a circulating wave. In the diagrams of the ring experiment shown in the last lecture I represented the circulating wave in its most simple form. The relations there shown between the advancing crest of the wave and its wake of retreat represent what is occasionally found in actual experiment. More usually, however, the relation in flutter is a little more complex. The gap between the crest and wake does not consist of wholly responsive but of partially refractory muscle (see Fig. II). The on-moving crest encounters many fibres which are responsive; it finds

some which are still refractory. These refractory fibres form minute barriers to its progress: it wends its way from side to side, passing only where it finds channels open and ready to receive it. It is as though a second prairie fire followed a first, but followed it at a time when the vegetation formerly burnt had not fully returned to its old condition; there would be places where the cinders of the first fire still blackened the earth, and the second flame in passing would creep around the edge of these before it could go forward. These barriers, by deflecting it, render the onrushing wave sinuous in its course, and delay its progress from point to point.

I said in my first lecture that in flutter the rate at which the wave is transmitted is not usually normal, but that it is slower than normal. We have proof that this delay is not due to change in the rate of fibre conduction, but to small barriers of unrecovered or refractory fibres. This observation is one of no little consequence, since it much simplifies our conception of those factors which are responsible for the maintenance

of circulating waves. The factors are three—namely, the length of the muscle path, the rate of propagation from point to point, and the duration of the effective refractory period. We now see that the second factor is controlled by the third. In large measure the length of the path is also controlled by the refractory phase; for, where several channels are open to the crest of the circulating wave it will take the shortest, and that is the path along which it most closely follows its own wake.

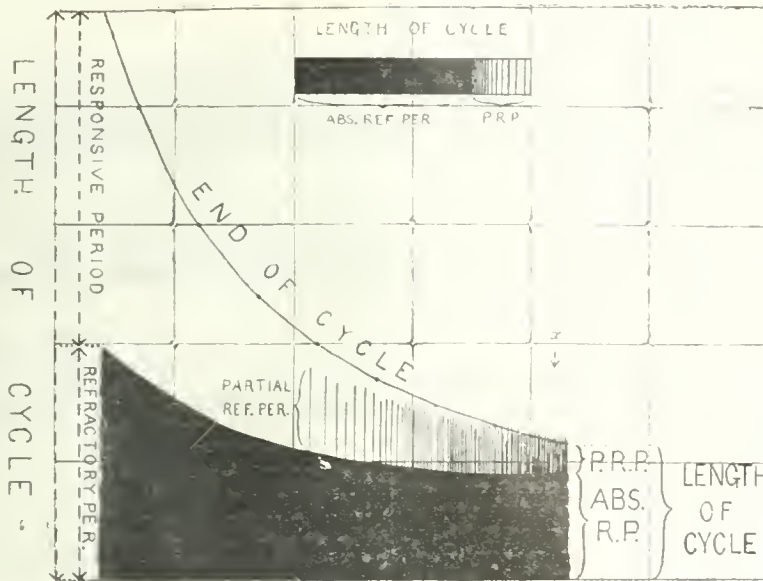

FIG. I.—The main diagram illustrates the relation of the refractory period to the length of the cycles when the auricular rate is raised by equal increments from its normal rate to a high level. The black portion of the diagram represents the absolute refractory period, which shortens as the rate is raised (that is, reading from left to right); a curved line indicates the shortening of the cycle itself. P.R.P.—period of partial refractoriness. ABS. R.P.—period of absolute refractoriness.



FIG. II.—A schematic representation of the excitation wave which circulates in flutter. The blackened portions of the ring represent those portions of the muscle which are refractory at a given instant. The crest of the wave travels constantly through the muscle in a partially refractory state. The border of the advancing wave is finely serrated.

FIG. III.—A similar representation of the excitation wave which circulates in fibrillation. The advancing border and retreating wake are deeply serrated, and these serrations overlap. The wave is constantly advancing through small and irregular channels of responsive tissue as these open up to receive it.

In studies of flutter, and in those of fibrillation, refractory period becomes of prime importance. Its length, and especially the length and character of its partial phase, are responsible not only for the maintenance of circulating waves, but, as we shall see, for the particular form of disordered movement which the auricle assumes.

THE PRODUCTION OF EXPERIMENTAL FIBRILLATION.

It has been stated previously that a frequent first step towards knowledge comes when we produce, by experimenting upon animals, a condition identical with that seen in our patients. In so far as fibrillation of the auricle is concerned that step was taken eleven years ago. At that time a condition termed fibrillation of the auricles was well known to experimenters, and a common form of disordered heart action was recognized in patients; but neither the experimental nor the clinical condition had been examined sufficiently closely to make it clear that the two states are one and the same. This identity was proved when the electrocardiograms of the experimental and clinical conditions were submitted to close comparison by Rothberger and Winterberg and myself in 1909, and when a little later I sought and obtained the opportunity of exposing to view the heart of a horse suffering from the same malady as do our patients.

Since the time of these demonstrations the term fibrillation of the auricle has come to be used universally in describing this particular disorder of the human heart. In Fig. IV I show again electrocardiograms of the experimental and clinical conditions. Treated pictorially the curves of auricular fibrillations are, within certain limits, variable; but exactly comparable variations are to be seen in man and animal. The variability of the picture is in large part governed by the action of the ventricles. As you are aware, the rate of the ventricular action is not always the same, neither is the degree of its irregularity in different samples of fibrillation. It is not difficult to choose from a collection of clinical curves on the one hand and experimental curves on the other hand, examples in which the resemblance is so close as to be convincing. With the details of the curves I need not now detain you, but would remind you of their most constant features. The ventricular representatives (*R* and *T*) are frequent and irregularly placed; the auricular representatives comprise a series of oscillations, of irregular form and somewhat irregular incidence and amplitude. The auricular representatives in flutter are united end to end; the action is quite regular and continuous, and its mean rate is approximately 300 per minute. The auricular representatives in

fibrillation are not very dissimilar to these; they are also joined end to end; and the action is again continuous. The auricular action in flutter and fibrillation differs, however, in important respects; thus, in fibrillation it is 50 per cent. faster, the oscillations having a mean rate of about 450 per minute; another difference is that in fibrillation the cycles are not accurately repeated; sometimes over short stretches of curve there may be at least a suggestion of repetition (as in the last record of Fig. IV), but close measurement will show that it is not precise; moreover, it is not long maintained. Change is the rule.

THE NATURE OF FIBRILLATION AND ITS RELATION TO FLUTTER.

I have pointed out that the first step in this inquiry was taken eleven years ago, when it was ascertained that the clinical disorder is identical with one which can be produced experimentally; but it is to be understood that we then obtained no close insight into fibrillation *qui fibrillation*. We had obtained knowledge of a disorder of the human heart, and, more important, the means of further investigating it. It is in

respect of these further investigations that I shall now speak. The method of research has been very similar to that employed in the case of flutter. We produce fibrillation of the auricles in an animal by suitable stimulation, and proceed to examine the paths taken by the excitation waves through the muscle while this fibrillation continues. It would be impossible for me to place before you in this lecture the details of this analysis; I can only attempt to acquaint you with the chief conclusions at which we arrive after fully considering

the evidence derived from all sources. The main conclusion is that fibrillation, like flutter, is maintained by a circulating wave. As in flutter, the central circulating wave is a single wave, but the circuit is completed in a shorter time; the auricular cycles, therefore, follow each other more quickly. To what is this quicker movement due ultimately? It is almost certainly due to the path of the circus movement being somewhat shorter than is the case in flutter. Why should the path be shorter? Probably

because in auricles predisposed to fibrillation the effective refractory period is shorter than in those predisposed to flutter. The crest of the circulating wave in both conditions tends to follow close upon its own wake. The refractory muscle forms a ring broken by a small gap; this broken ring, regarded as a whole, revolves. Now the length of refractory tissue in this ring at any given instant is obviously controlled by the duration of the refractory period. A decrease in the refractory period shortens the length of the tissue involved in this

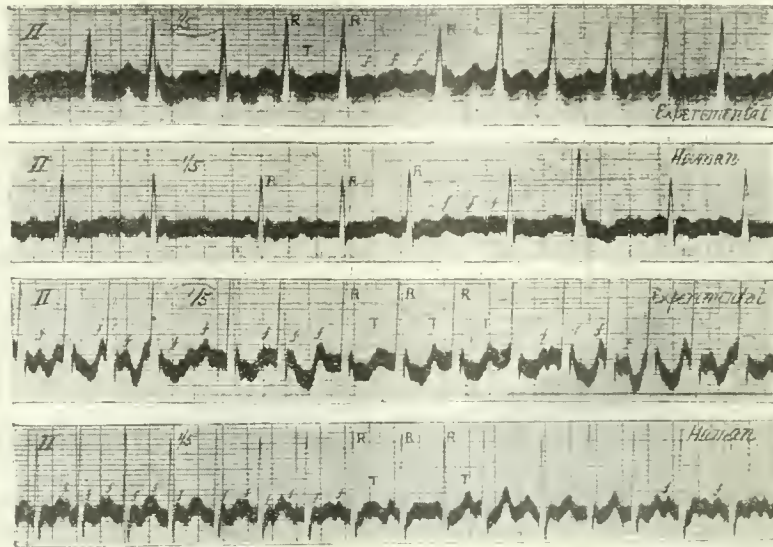

FIG. IV.—Four electrocardiograms (lead II) illustrating fibrillation of the auricles in man and the dog. The first and third curves are from dogs, and have been taken from recent experiments in which fibrillation of the auricles has been analysed. These two curves should be compared with the second and fourth respectively; these last are examples of clinical fibrillation. *R* and *T* are ventricular deflections; *f* are the oscillations arising from the fibrillating auricles.

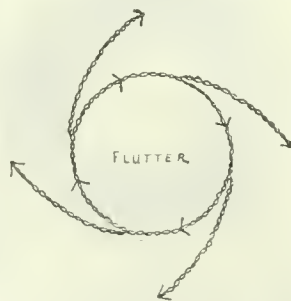

FIG. V.—A diagram illustrating the successive paths followed by the excitation wave in flutter. The path is finely sinuous, but is in general accurately repeated from cycle to cycle.



FIG. VI.—A similar diagram of the successive paths taken in fibrillation. The path is coarsely sinuous and ever-varying, though it continues to progress in a clockwise fashion around a central area.

state at any given moment; consequently, if the gap remains unaltered, the diameter of the ring must shorten. If a snake glides along the path taken by its own tail, the size of the circle which it inscribes will be controlled by the length of the snake.

We believe that in fibrillation the circuit is smaller in diameter than in flutter. We cannot yet describe with confidence the precise paths which are followed; but there is some direct evidence to suggest that the mouth of the superior cava is one of the circuits which the central wave favours. Where precisely the circuit is situated is of little moment. To recognize that a single circuit exists should suffice.

The difference between fibrillation and flutter is in part one of rate; but that is not the sole difference or even the most important difference. It has been shown to be the rule that in flutter the crest of the circulating wave is constantly passing through tissue in a partially refractory state. The wave as it progresses strikes upon small barriers which render its course finely sinuous. In fibrillation this interference is much exaggerated; the barriers are larger and the crest travels along paths coarsely sinuous. Seemingly, the crest has not a straight or simply curved border of advance; it is deeply and irregularly crenated. Its wake is similarly crenated and the crenations of the one and the other overlap and intertwine; this relation is shown diagrammatically in Fig. III. The crest of advance moves through muscle apparently in a denser state of partial refractoriness than is the case in flutter.

Picture the path travelled by the wave after it has circulated several times in flutter (Fig. V). There is the track of the central re-entering wave; the path taken is finely sinuous, but apart from these very minor variations it is constant. As this mother wave circulates in the main channel it throws off centrifugal waves at each revolution, and these proceed into outlying areas of the muscle, such as the appendices and the sleeves of muscle on the cavae; along these outlying channels the path is also finely sinuous, but in general constant. The whole muscle of the auricle is involved in each cycle. With each revolution the events are repeated; the waves are signalled with almost perfect regularity in every part of the musculature; at each revolution a wave passes to the region of the A-F node, the responses of the ventricle are, therefore, of an orderly character.

Picture similarly the path which the wave has followed after it has circulated several times in fibrillation (Fig. VI). Everywhere the track is coarsely sinuous. There are the central tracks, spread over a wider band of tissue than in flutter, because the path varies. Speaking very broadly, the same central path is trodden over and over again, but in detail there is no constancy. The wave may, and apparently does, encircle the same central area repeatedly if not continuously, but it staggers along its course; it is a road of many and serious obstacles. For that reason it does not return to its starting point after constant intervals of time; for that reason and because of change in the actual path pursued, the oscillations in the electrocardiograms are of irregular incidence and form. The paths through the outlying muscle also vary. Place contacts on any region of the auricular muscle, and the waves are not signalled regularly as in flutter, but irregularly; a few even fail to arrive at their proper destinations. With each irregular revolution, or at least with most, a wave passes to the region of the A-F node. These waves arrive at the node more frequently than they do in flutter, for the general movement is somewhat faster; but because the path travelled is coarsely sinuous and variable they arrive at the node irregularly. The responses of the ventricle are therefore irregular.

THE ACTUAL CIRCUITS IN FLUTTER AND FIBRILLATION.

A single circulating wave is responsible both for flutter and for fibrillation of the auricle; in both conditions it follows the re-entrant path repeatedly, though in flutter this repetition is far more exact than it is in fibrillation. We

¹ Though the band of tissue involved in successive circuits is wider, the average circle is probably of lesser diameter, as already stated. The shorter diameter is not represented in the accompanying diagram.

² The waves which reach the A-F node are approximately one-tenth less numerous than those which flow along the central path. In the average they number, therefore, about 400 per minute in human fibrillation.

possess some definite knowledge of the actual paths followed by the wave in the fluttering auricle of the dog. The wave may encircle the mouth of the superior cava and include a variable amount of tissue lying between this vessel and the inferior cava; or it may encircle together the mouths of both superior and inferior venae cavae; it is probable, though it is not proven, that circuits are formed in some instances around the auriculo-ventricular orifices.

In man the rates in flutter are from 240 to 350 per minute; in the dog the rates are 345 to 580 per minute. In other words, the rates in the dog are approximately 50 per cent. faster. Difference in the size of the organ in man is sufficient to explain this difference of rate, if we assume the rate of transmission in the human and canine auricles to be equal. We may arrive at a general, if we cannot arrive at a precise, idea of the ring's circumference in the human subject. Thus, if the rate of a human flutter is 240 per minute, the duration of each cycle is 0.25 of a second; if the rate is 350 per minute, the duration of each cycle is 0.17 of a second. Assume that the transmission rate in flutter is 500 millimetres per second, then the length of the path will be 125 millimetres in the one case and 85 millimetres in the other, and the diameters of the corresponding circles will be 4 and 2.7 centimetres respectively. Thus, if our assumed transmission rate is correct, the circular paths in flutter are of diameters somewhat exceeding the diameters of the chief orifices of the auricle. It is these natural orifices to which we look especially in attempting to locate the actual paths of the waves.

In human fibrillation the rate of movement is faster; it lies usually in the neighbourhood of 450 per minute, the cycle having a duration of 0.13 of a second. If we assume the same transmission rate, then the length of the path would be 66 mm., and the diameter of the circle would be a little more than 2 cm. It will be evident that if this estimate is approximately correct, and if we suppose the chief orifices of the auricle to be those encircled by the waves in fibrillation, that in this last condition the encirclement must be a very close one. The factor which remains in doubt is, of course, the rate of transmission.

These remarks, Sir, bring me almost to the end of what I propose to record in the present lectures. I may have been tempted to speak of possible remedies for the state of affairs which I have described, but the subject is still unripe for discussion; perhaps I have said enough in indicating what seems to me one of the chief lines which investigation should take: it is an investigation of the refractory period of heart muscle, a search for remedies which will influence the duration of this refractory state, and which, by prolonging it, will help us to close the gap between the crest and wake of the circulating wave; for this gap is essential to the maintenance of the circulating wave, whether the circulating wave is responsible for flutter or for fibrillation.

Finally, the lecturer proceeded to demonstrate shortly his recent experiments with Dr. Drury and Dr. Hiescu upon the movements of the electrical axis of the auricle in clinical flutter and fibrillation. If suitable planes are chosen it can be shown, in both these conditions, that the electrical axis changes its direction in a definite and striking manner; it revolves through a definite auricular cycle is completed. As the electrical axis is broken as an index of the general direction of the wave as it is travelling, these observations, however made in flutter and fibrillation, the way may be followed in a similar fashion through the auricle. Taken together with the experimental evidence they furnish a good example of simple circus movements in the human auricle affected by these two disorders.

Note. Further details of the experiments with the watch will be found in the *Journal of the Royal Society of Medicine*, vols. vi and vii.

ON the occasion of the 50th anniversary of the discovery of the Roentgen rays a monument will be inaugurated at Petrograd to Professor Roentgen and a street will be named after him.

THE fifth meeting of the German Urological Society will be held at Vienna from September 29th to October 1st, when the following subjects will be discussed, (1) Pathology and treatment of hydronephrosis, (2) surgical anatomy of the bladder and ureters in relation to extensive resections.

THE ETIOLOGY OF RICKETS:

AN EXPERIMENTAL INVESTIGATION.

BY

D. NOËL PATON, M.D., F.R.S.

REGIUS PROFESSOR OF PHYSIOLOGY IN THE UNIVERSITY OF GLASGOW;
AND

A. WATSON.

(From the Institute of Physiology, University of Glasgow.)

(Abstract.)

SINCE 1907 investigations upon experimental rickets in dogs have been carried on in this laboratory, first by Leonard Findlay,¹ then by Renton and Madge Robertson,² and subsequently by Noël Paton, Findlay, and Watson.³

These last experiments showed that while all the pups of two litters kept in the laboratory upon an abundant supply of whole milk and oatmeal porridge developed rickets, two pups from each of the litters kept in the country on skimmed milk and oatmeal remained free of the disease.

The present series of observations shows that pups kept in the laboratory develop rickets even on an abundant supply of milk fat (as much as 7.5 or even 11 grams per kilo) and oatmeal porridge, but that those on the same amount of separated milk (0.2 to 0.7 gram of milk fat) and porridge develop the disease more rapidly. The energy value of the separated milk diet was necessarily lower than that of the full milk diet (207 to 267 calories as against 270 to 437 calories), and hence it is possible, as is suggested by the observations on infants by Hess and Unger,⁴ that a low energy intake may predispose to the disease, although it is not a causal factor.

To test this the next experiment was arranged so that pups of three litters, which were available at the time, should have the diet increased proportionately to their increase in weight, and that the energy intake should be kept ample throughout the period of growth, but that, while one series of pups should have the energy supplied largely from whole milk—fresh and dried—with bread, another should have it from dried separated milk and bread, another from lard, which the Vitamin Committee⁵ of the Medical Research Council class as a fat free of their anti-rachitic vitamin, and the last series from dried separated milk and bread. Scrupulous care as to cleanliness was observed throughout this experiment.

The result was that all the pups, with one exception, reached fifteen to eighteen weeks free of rickets, although those upon the separated milk and bread diet had only 0.3 to 0.6 gram of milk fat per kilogram per day.

The basis of Mellanby's⁶ experimental work is that separated milk up to 250 to 350 c.cm. and white bread, even with linseed oil, yeast, and orange juice, will not prevent the onset of rickets in pups between six and twelve weeks of age, while whole milk will prevent it, and upon this is based the practical recommendation of the Vitamin Committee,⁵ p. 99, that full cream milk should be used by children for the prevention of the disease.

Butter is placed with cod-liver oil (p. 102) as the substance richest in "fat-soluble A or anti-rachitic factor," but both of the two pups in our series to which butter was administered in large quantities developed rickets, while its administration failed to cure or to prevent the advance of the disease in another.

Our experience indicates that by attention to strict cleanliness it is possible to rear pups free from rickets in a laboratory. It is easy to rear them in the open air, even on a diet poor in milk fat. The work of Morpurgo on white rats, and the study of an epidemic of rickets among foxhounds in Adelaide by Bull,⁷ taken along with our results, point to the probability that a bacterial infection of the same non-specific character as that which the investigations of McCarrison have shown to be the causal factor in goitre, plays an important part in the etiology of the disease.

A point of considerable interest demonstrated in our observations is the more rapid growth of the pups kept in the open air.

A detailed account of the experiments is published in the April number of the *British Journal of Experimental Pathology*. The expenses of the investigation were defrayed by the Medical Research Council.

CONCLUSIONS.

1. In young dogs, under ordinary laboratory conditions, a liberal allowance of milk fat up to even 14 grams per kilo of body weight neither prevents the onset of rickets nor cures it when it has developed.

2. Pups kept largely in the open air may escape the development of rickets on an intake of less than 1 gram of milk fat per kilo body weight.

3. With scrupulous care as to cleanliness it is possible to rear pups free of rickets in the laboratory on an intake of only about 0.5 gram of milk fat per kilo of body weight, along with bread, provided that the diet affords an adequate supply of energy.

4. The energy value of the diet, however supplied, quite apart from the presence of any hypothetical anti-rachitic factor in milk fat, would seem to play a part in controlling the development of rickets, but that it is only a contributory part is shown by the development of rickets in pups with a high energy intake when they are confined in the laboratory without scrupulous care as to cleanliness.

5. Milk fat may be reduced to about 0.3 gram per kilo of body weight, if its place is taken by an equal amount of lard, without the onset of rickets.

6. The results of these observations do not support the conclusion of the Accessory Food Factors Committee of the Medical Research Council that rickets is a deficiency disease due to lack of an anti-rachitic factor associated with milk fat.

REFERENCES.

- ¹ L. Findlay, *BRITISH MEDICAL JOURNAL*, 1908, ii, 13. ² J. M. Renton and Madge B. Robertson, *Journ. Pathol. and Bact.*, 1916-17, xxi, 1. ³ D. Noël Paton, L. Findlay, and A. Watson, *BRITISH MEDICAL JOURNAL*, 1918, ii, 625. ⁴ A. F. Hess and L. J. Unger *Journ. Amer. Med. Assoc.*, 1920, 74, 217. ⁵ Report on the Present State of Knowledge concerning Accessory Food Factors (Vitamins), compiled by a Committee appointed by the Lister Institute and the Medical Research Council, *Med. Res. Com. Spec. Rep. Series*, No. 38, London, 1919 (H.M. Stationery Office). ⁶ E. Mellanby, *Lancet*, 1919, i, 407. ⁷ Bull, *Journ. Compar. Pathol. and Therap.*, 1918, xxi, 193.

A TUBERCULOSIS IMMUNIZING VACCINE.

BY

NATHAN RAW, C.M.G., M.D., M.R.C.P., M.P.,

PRESIDENT, TUBERCULOSIS SOCIETY OF GREAT BRITAIN.

OF all the serious infections of the human body tuberculosis is the most hopeful, both as regards its prevention and also its cure, provided that treatment can be commenced early enough and continued long enough to give the affected tissues time for repair.

In spite of an enormous amount of research, continued in all parts of the world, we have reluctantly to admit that we have not yet obtained a specific remedy which will effectively destroy tubercle bacilli in the body. We must therefore rely on producing a sufficient immunity in the tissues to resist the attack by virulent tubercle bacilli. This immunity can be obtained:

1. By increasing the natural resistance by means of increased nutrition and sound hygienic conditions.
2. By producing an artificial active immunity in the tissues to the tubercle bacillus itself.

Increased care in infant welfare, better wages to the industrial classes, good nourishing food, a pure milk supply, the prevention of overcrowding, and, above all, good housing conditions and the segregation, of open cases of pulmonary tuberculosis, will obviate to an increasing extent the possibility of direct infection; but all this will take many years to accomplish. In the meantime I feel strongly, from my experience of treating many thousands of cases of tuberculosis in hospital, that we have at our disposal a scientific means by which we can secure some immunity to the bacillus, and certainly of preventing the extension of the disease in the human body when once introduced. Fortunately for civilization, the tubercle bacillus is a parasite and not a saprophyte. It has no existence outside the living body, otherwise the whole community would be endangered.

In the *BRITISH MEDICAL JOURNAL* of 1903 I published a preliminary note, the gist of which was that human and bovine tuberculosis were separate and distinct infections, producing a different set of symptoms in the human body. The lesions caused by the human bacillus (direct infection)

are pulmonary tuberculosis, tuberculous laryngitis, secondary intestinal ulceration, and, in some cases, lupus. The lesions due to the bovine bacillus, and generally caused by infected milk in the early years of life, are tuberculous glands, mesenteric tuberculosis, surgical tuberculosis of bones and joints (frequently), tuberculous meningitis, and some cases of lupus.

I still hold to this classification and differentiation of the effects of the two forms of bacilli, and, in addition, I firmly believe that the one form confers an immunity in the body to the other. In fact, the two varieties of bacilli will not exist together in the body at the same time.

To some extent this is of great importance in treating the disease, as we are only able to produce immunity in animals by using human bacilli of ordinary virulence, or by attenuating the bovine bacillus to such an extent that it is non-pathogenic.

After treating over 2,000 cases of tuberculosis in hospital with Koch's tuberculin, prepared from virulent cultures, I came to the conclusion that, although a certain amount of success was obtained, the results were not on the whole satisfactory. The uncertain action of the tuberculin and the alarming reactions sometimes produced were very disconcerting, and there is no doubt that in some cases quiescent tubercle was stirred to acute activity.

For this reason I came to the conclusion that it was essential to use cultures of very low virulence, and to avoid, if possible, general febrile reactions. The only certain way of permanently attenuating virulent cultures of tubercle bacilli is by long-continued and systematic subculturing spread over a number of years. In 1906 Professor Koch gave me in Berlin a pure culture on glycerin agar of human bacilli from the sputum of an advanced case of pulmonary tuberculosis. Professor Calmette supplied me with a pure culture of bovine tuberculosis obtained from the mesenteric glands of a cow, and Professor Bang of Copenhagen gave me a pure culture of avian bacilli from the liver of a chicken.

These cultures have been subcultured on glycerin potato and then transferred to glycerin agar, every month for fourteen years in my laboratory, and the present growths represent the 184th generation. The growths are still profuse and true to type, but they are quite non-tuberculinogenic and completely non-pathogenic to animals. Every year since 1906 I have injected these bacilli into animals with a view to testing their pathogenicity. Until the year 1912, that is, the 94th generation of subcultures, I noticed no change in their virulence. After that time attenuation became marked, and in a series of animal inoculations of these bacilli in 1913 and 1914 they were observed to be avirulent.

The war interfered seriously with my experiments, but I took the cultures to France and continued the work there for four years, inoculating hares, rabbits, and guinea-pigs in 1916 and 1917. The cultures were in all cases non-pathogenic. In 1919 I inoculated more animals at the Lister Institute, and although large doses were given, no infection whatever was conveyed, and the animals remained alive and well for four months.

These experiments, which have occupied me for fourteen years, conclusively prove that virulent tubercle bacilli can be attenuated to such a degree as to be avirulent and non-pathogenic to highly susceptible animals, and in my opinion we have in our hands a remedy against tuberculosis which will be of the greatest value, not only in the cure of the disease, but what is of still greater importance, in its prevention, by protecting the human body against attack.

Natural attenuation, while removing the virulence and toxicity of the organism, enhances the value of the vaccine in the treatment of disease. In the case of small-pox the immunity derived from an inoculation of the virus from the pustules of vaccinia is considerably greater than that which results from an attack of variola, because the defensive elements in the body have not been weakened in overcoming the virulence of the toxin.

Treatment of disease by vaccines prepared from organisms attenuated naturally means that the production of antibodies will take place rapidly without any preliminary shock to the system such as invariably follows the injection of a vaccine prepared from a virulent strain of bacteria. Hitherto it has not been possible to test this in

tuberculosis, owing to the length of time necessary to produce a non-pathogenic strain of the tubercle bacillus.

The results of my work on animals conclusively prove that immunity against infection is produced by the injection of attenuated bacilli, and it is reasonable to suppose that the same thing will hold good in the human. Cattle can be rendered immune to virulent bovine bacilli by previous inoculation with virulent human bacilli; and I am convinced that there is a marked antagonism in the human body between human and bovine infections. It is an indisputable fact that these two organisms cannot flourish in the body at the same time. A child who develops primary abdominal tuberculosis with involvement of the mesenteric glands, or an infection of the neck glands, which are usually caused by the bovine bacillus conveyed in tuberculous milk, is immune to infection by the human bacillus for the remainder of life, and young adults attacked by the human bacillus, producing primary pulmonary tuberculosis, are immune to bovine infections for the rest of life.

The scientific means at our disposal at present for the accurate differentiation of human and bovine infections in the body are not sufficiently accurate to be decisive. There are atypical strains of bacilli which cannot be classed with certainty in either group, and the varying virulence of these bacilli and their effect on susceptible animals is still a matter of some uncertainty in a fair number of cases.

With a view to elucidating this doubtful point as to the real amount of tuberculosis in man caused by these two types of bacilli, and also as to the immunity produced by one infection towards the other—in other words, in order to obtain an answer to the question whether the disease caused by the human bacillus is antagonistic to that caused by the bovine bacillus and vice versa—I instituted clinical observation on a large scale in a Liverpool hospital containing 900 beds, of which I had sole charge for eighteen years. During that time I had the opportunity of treating over 10,400 persons suffering from tuberculosis in all its various forms.

Two hundred beds were devoted to tubercle. Half of these were cases of primary pulmonary tuberculosis; the other half of surgical tuberculosis—glands, bones, joints and lupus. During a period of thirteen years 4,800 cases of phthisis passed through the human wards and 1,820 cases of surgical tuberculosis passed through the bovine wards—a total of 6,620 patients.

The object of the observation was to see what other lesions, if any, were developed in the patients suffering from pulmonary tuberculosis, and how many of the surgical cases developed lesions in the lungs. I was assisted in this work by many excellent house-physicians and nurses, and the results were very striking and important.

In no case of primary pulmonary tuberculosis did we observe during the course of illness tuberculosis of bones, joints, glands, or skin, nor any instance of meningitis. Several cases developed brain symptoms in the last stages of the disease, but they were due to insanity, toxæmia, or exhaustion, and of the cases with meningeal symptoms, those examined *post mortem* were found to be cases of pneumococcal meningitis.

Amongst the surgical cases of tuberculosis 28 developed lung symptoms, and these were all examined by laboratory methods and animal inoculation; 25 died and were carefully investigated *post mortem*. In all cases the infection of the lung was either by direct extension from cervical glands to the apex of the lung, or from a primary focus in the abdomen extending upwards through the diaphragm to the bronchial glands and lungs.

This large clinical experiment convinced me that the human body is attacked by two quite distinct forms of tuberculosis—the one conveyed from person to person by direct infection and attacking chiefly the lungs, or so-called consumption, and the other conveyed by milk from tuberculous cows, and developed in the first few years of life.

These two diseases are caused by different types of tubercle bacilli which will not live in the body at the same time, and, what is of the highest importance, one disease produces immunity to the other.

I have emphasized this point of antagonism between the two infections to show my reason for always using a vaccine prepared from bovine cultures in the treatment of the human infections and vice versa.

The varying degree of virulence of the attacking organism is of supreme importance. The great majority of cases of tuberculosis are fortunately of low virulence, and, given suitable conditions, are favourable for treatment; but in some cases the virulence is so high as to destroy the person in a few weeks or months, and these are the cases popularly known as galloping consumption.

From my own observation I am inclined to think that in this country the virulence of the tubercle bacillus is less than it was thirty years ago. The number of deaths in England and Wales from tuberculosis in 1920 was 12,000 less than in 1919, a most gratifying record of progress in dealing with this terrible disease, which destroys 60,000 lives each year in England alone.

A large percentage of the population receive at some period of their lives a mild infection of tubercle which, in many cases, produces no definite symptoms. These persons recover, and are to some extent immunized against a further and more severe infection.

If we can induce some immunity by artificial means in children whose parents or relatives are tuberculous, and who by constant association with them are very liable to infection, we will have gone a long way towards stamping out tuberculosis. As Roemer says, "The most important problem in the prophylaxis of consumption is the saving of children in phthisical homes from severe tuberculous infection."

The vaccine which I have had prepared from these attenuated cultures is a bacillary emulsion of the bacilli, and contains all the products of the bacillus. It is non-toxic and avirulent, and produces no reaction even in large doses.

For purposes of immunization in susceptible children six injections are given at weekly intervals, and repeated in three months. The doses recommended are 0.001, 0.002, 0.003, 0.004, 0.005, and 0.006 mg. No symptoms whatever have been observed to follow these injections.

In the treatment of the active disease the doses used are much larger than have been possible hitherto; it is recommended that the treatment should consist of at least twelve injections given in increasing doses at intervals of seven days. The doses commence at 0.001 and increase to a maximum dose of 0.025 mg. The vaccine should be freshly prepared from the cultures, and should not be used after one month.

Our chief object in the treatment of active tuberculosis is to limit the spread of the disease in the organs. If we can locate a recent deposit in the apex of a lung, and prevent its extension throughout one or two lobes, the patient will have a good chance of recovery, and I maintain that we can only do this if we can provide his blood with some active immunity with which to resist the infection.

This vaccine, prepared as it is from avirulent cultures, can be used with complete safety in any stage of the disease, and even in advanced cases I have observed great relief from night sweats, toxic symptoms, and erratic temperatures. I have treated 118 cases of tuberculosis with various forms of the products of these attenuated bacilli, but I have decided that the bacillary emulsion is the best preparation.

The results in suitable cases are excellent, but it would require at least two years to gauge accurately the effect of the vaccine for purposes of immunization.

I have succeeded in completely immunizing highly susceptible animals against tuberculosis by the use of attenuated cultures which have required fourteen years' subculturing in the laboratory, and I firmly believe that if all children with a tuberculous history could be safely vaccinated in the manner I have described they would be placed in a better position to resist infection at home.

Prevention is better than cure: and if we are to eradicate consumption, as I firmly believe we will, it can only be by preventing infection of healthy people, and especially children, rather than by devoting all our energies to the cure of those already infected.

The amount of tuberculosis conveyed to infants and young children in milk derived from dairy cows suffering from tubercle is enormous. It is estimated that over one million dairy cows in this country alone are tuberculous, and there seems to be no improvement in this disgraceful state of affairs. The simple process of raising the temperature of the milk to 190° F. makes it perfectly safe,

and does not in the slightest degree impair its nutritive value. Sterilized and proprietary milks are quite safe, and free from tubercle, and should be used in preference to unboiled cow's milk.

THE SURGERY OF THE PERIPHERAL NERVE INJURIES OF WARFARE.*

BY

HARRY PLATT, M.S. LOND., F.R.C.S. ENG.,

SURGEON, AND SURGEON-IN-CHARGE OF ORTHOPAEDIC SERVICE, ANCOATS
HOSPITAL, MANCHESTER; SURGEON-IN-CHIEF, GRANGE THORPE
ORTHOPAEDIC HOSPITAL (MINISTRY OF PENSIONS),
MANCHESTER.

ANALYSIS OF A PERSONAL SERIES OF OPERATIONS.

General Survey.

An analysis of the total operations performed in my services in the period from March, 1915, to December, 1920, is given in Table I. The figures may be taken as representative of an average individual operative experience, and it is therefore safe to refer briefly to certain general information that the statistics themselves afford.

The frequency with which the ulnar nerve called for treatment, the infrequency of operations on the brachial plexus, and the complete absence of any operation on either the musculocutaneous or circumflex nerves in the upper limb, or the anterior crural nerve in the lower limb, are facts to be noted.

In the various types of operation the phases through which the operator passed are illustrated in the large number of operations of the bridge type, and those in which repair was abandoned.

Analysis of Results.

Of the operations in this series it has been possible to investigate the early and later results over periods extending from six months or more in 248 only.

It must be admitted at the outset that this study includes few if any true end-results. The most reliable records in our possession are those of the operations performed since 1917, when the advantages of a more efficient segregation of the patients, and the inauguration of the follow-up system were available. But though the conditions were such as in civil surgery might be considered ideal, the greater number of the patients could be kept in hospital for short periods only, and were then distributed in various parts of the country. This difficulty, which has been experienced by all surgeons, explains the comparative paucity of the operation statistics hitherto available.

TABLE I.—Total Operations.

	Suture.	Neurolysis.	Bridge.	Repair Abandoned.	Partial Suture.	Exploration: No Lesion.	Exploration: Nerve left in situ.	Injection.	Exploration: First Stage.	Total.
Brachial plexus ...	5	4	—	—	—	2	—	—	—	11
Musculo-spiral ...	51	15	5	14	—	1	—	—	—	87
Median ...	70	45	6	—	5	2	3	1	1	132
Ulnar ...	115	49	12	—	—	1	5	—	—	182
Posterior interosseous	1	—	1	—	—	—	—	—	—	2
Sciatic ...	51	9	3	—	2	1	—	—	4	70
External popliteal ...	14	2	—	6	—	—	—	—	—	22
Internal popliteal ...	—	2	—	—	—	—	—	—	—	2
Posterior tibial ...	—	1	1	—	—	—	—	—	—	2
Total ...	307	127	28	20	7	7	8	1	5	510

Operations for severe causalgia, 25—

Median 14

Sciatic 10

Internal popliteal 1

Operations in which end-to-end suture failed, 53.

Successful suture at second attempt, 1.

Failure of suture at second attempt, 3.

* Part of a Hunterian Lecture on The Results of Operations for the Repair of Nerve Injuries, delivered before the Royal College of Surgeons of England.

In this post-operative study the presence or absence of signs of recovery have been recorded after personal examinations only. Whilst many patients living at a distance have from time to time replied to inquiries as to their progress, suggestions in their reply indicating recovery or otherwise have always been ignored. It is perhaps unnecessary to lay stress on the fallacies of conclusions drawn from such impersonal investigations; my excuse is that one has occasionally seen in the possession of out-patients forms which were to be filled up recording the impressions of the man himself on the alterations in the sensory and general functional condition of his limb.

The 248 operations from which information as to results have been available include 150 cases of end-to-end suture, 80 of neurolysis, and 18 of bridge operations.

RESULTS OF END-TO-END SUTURE: 150 OPERATIONS.

In a preliminary report based on a study of 271 suture operations, issued a year ago by my colleague Stopford,¹ the bulk of my own operations up to date were included. The experience of a further period of twelve months has made it possible to collect additional evidence concerning the fate of a considerable number of the patients with whom we have been in touch.

TABLE II. End-to-end Sutures: Total, 150.

	Total.	Proximal Muscles only.	Proximal and Distal (incomplete).	Proximal and Distal (total).	Distal alone.	Associated Sensory Recovery.	Sensory Recovery alone.	Number of Recoveries.	Failures.
Musculo-spiral ...	35	10	11	5	—	all	—	26	9
Median:									
Upper arm ...	10	7	3	—	—	in 5	—	10	nil
Forearm ...	20	3	—	—	6	in 6	8	17	3
Ulnar:									
Upper arm ...	27	19	3	—	1	in 14	1	24	3
Forearm ...	20	—	—	—	10	in 14	7	17	3
Sciatic: Trunk ...	21	16	nil	nil	—	in all	—	16	5
Segmental ...	4	2	nil	nil	—	in all	—	2	2
External popliteal ...	9	4	nil	—	—	in all	—	4	5
Posterior interosseous	1	—	—	—	—	—	—	nil	1
Plexus ...	3	2	—	—	—	2	—	2	1

Recovery, 118 = 79 per cent.; failure, 32.

The frequency and type of recovery after nerve suture are illustrated by the statistics in the tables. The facts as to the recovery of motor function are arranged under the headings of the proximal and distal muscle groups, a classification which is found to be convenient, particularly for the upper limb. In the whole series there are no examples of absolutely complete and perfect recovery, excepting possibly in 5 of the cases of musculo-spiral and 2 of those of external popliteal suture.

The operations in which the existence of recovery is charted include every variety and type of incomplete restoration of conduction in the sutured nerve. It is not considered a logical procedure to classify such recoveries into further arbitrary special divisions, such as "slight," "marked," and so on, for the simple reason that the periods of post-operative observation are not constant for any one group of allied operations. Given long periods of time, many of the imperfect recoveries of to-day will progress, or have already progressed, towards the stage of complete recovery. The standard of failure adopted in my analysis is the complete and stationary absence of recovery after a year or more, in some cases confirmed by evidence obtained on re-exploration.

With regard to sensory recovery, in very few cases has there been more than a slight recession of analgesia or an incomplete restoration of protopathic sensibility.

The information and conclusions as to the late results of suture may best be embodied in a consideration of the main factors which have determined, delayed, or entirely prevented success.

1. The Period of Delay between the Original Injury and the Performance of the Operation.

In my own series the influence of the time factor has been definitely proved. As a general rule sutures performed within a period of eighteen months show little appreciable differences in the time of the onset of recovery, or the rate and ultimate completeness of the recovery. After a delay of two years recovery is often tardy or incomplete: in some cases it fails completely. This truth has long been established as a fundamental factor in prognosis in the older nerve surgery (Kennedy).²

My records confirm what has been pointed out in Stracker's careful analysis of the operations performed in the clinic of Hans Spitzky of Vienna—that the degree of delay within the safe period does not influence the percentage of cases showing recovery, and does seem to prejudice the ultimate quality and type of the regeneration. In complete failure the time factor, quite apart from other influences, plays an important part. It is assumed that this is dependent on the development of permanent retrogressive changes in the spinal cells, and to a much less degree to peripheral degenerative changes in the muscles. On the other hand, it would appear from the analysis of the operation results in the service of Sir Harold Stiles of Edinburgh that this factor exerted a negligible influence (Forrester Brown).

2. The Recrudescence of Septic Infection in the Limb.

Recrudescence of infection at a period after the suture was seen in a number of cases in my series; where this arose spontaneously it does not appear always to have affected the regenerative process, but it has been my fate to see a definite recession in the regeneration which had already begun, after the exploration of an associated ununited fracture, followed by infection. This unfortunate sequela is one which could have been avoided, and perhaps is hardly to be cited as a fair test of the resistance or lack of resistance to sepsis of the regenerating nerve. In the recovery stage of a number of cases of suture of the sciatic nerve the trophic ulceration seen under the base of the fifth metatarsal, or in the terminal phalanx of the great toe, where definite necrosis has resulted, provides a continued source of infection, which might conceivably be absorbed and travel upwards towards the area of suture. Delay or cessation in recovery has been invariably associated with this complication, and I would suggest that it is in some way connected with the absorption by the regenerating nerve of distal sepsis.

3. Anatomical Situation of the Suture.

The distance of the line of suture from the spinal centres, or conversely from the distal extremity of the limb, is seen to be an important factor in determining the fate of the regenerative process. This is illustrated by a study of the time of onset of the appearance of recovery in the muscles supplied at successive levels, and in a comparison between the results of suture in the proximal and distal parts of the limb respectively. The times of the appearance of recovery in the chief muscle groups have been carefully charted in Stopford's recent contribution, and are seen also in the monograph of Stracker already referred to.

Recovery in the proximal muscles begins at an earlier or later date according to the proximity of the suture to the spinal cord, and occurs in regular descending fashion in accordance with the anatomical origin and distribution of the motor branches. Thus, for example, after suture of the musculo-spiral nerve in the upper, middle, and lower third of the arm, return of power is manifest in the supinator longus at about the seventh, sixth, and fourth months respectively. Distal recovery also shows these differences in time relation. In Stracker's figures no recovery was seen before one year after suture in the distal muscles of the musculo-spiral, median or ulnar supply, and this irrespective of the level of the suture. On the whole this is borne out by the records of my own operations. Thus the time taken in neurotization of the distal muscles is not entirely dependent on the distance which down-growing axons have to travel. It has been concluded from this that the results of suture are better in the proximal part of the limb than in the distal. Stracker states that, in general, sutures below the origin of the proximal muscle branches give bad results. This would appear to be correct as a broad statement, but on careful

examination requires certain qualifications. If the results of suture of the median and ulnar nerves in the upper arm and forearm are compared as regards distal recovery alone, both motor and sensory function combined, which means that a period of twelve months at least must have elapsed, the quantitative recovery appears to be roughly equal in each group.

4. Influence of Topography.

The inaccuracies of regeneration due to the shunting of motor fibres along sensory channels and vice versa are undoubtedly one of the causes of imperfection in the recoveries, and may be of such a degree as to determine complete failure. It has been impossible in a close perusal of one's operation records to correlate in each case the potential influence of this factor with the type of recovery seen. In the sciatic nerve sutures it has been easy to retain an accurate topography, whilst in the musculo-spiral the comparatively scanty sensory bundles, even when misdirected, have not prevented the transmission of a large proportion of motor fibrils along appropriate channels. The exact rôle of topographical errors, as applied to the individual operations, cannot be settled until it is possible to examine a large number of successful sutures of the median and ulnar nerves after a period of three years or more. In certain situations—for example, in the lower half of the forearm—where suture of either the ulnar or median nerves has been achieved with what might be claimed as faultless topography, little direct proof of its beneficial effect is obtained.

Topographical failure is best illustrated by the suture of a nerve of smaller calibre to a larger trunk, as in the case of suture of the posterior interosseous to the musculo-spiral, and of the anterior tibial and musculo-cutaneous to the external popliteal—operations which account for 8 cases traceable in my series, and in all of which complete failure resulted. The topographical factor in regeneration is, however, usually cited as an illustration of the apparent superiority of the results of suture of the musculo-spiral nerve over those of the median and ulnar nerves, and of the delay or absence of recovery in the distal muscles.

5. The Influence of Perineural Surroundings— The Nerve Bed.

It does not appear from my own observations that the perineural surroundings have influenced the occurrence of recovery after nerve suture in any way, except in a few cases where the nerve trunk has been subjected to the friction of a bony groove, as in the case of the ulnar at the elbow, or has been left in close relation to bare tendons—for example, median suture at the wrist. The deleterious effects of a nerve bed of this type have contributed to the complete failure of one case of ulnar and one of median suture, but such failures are to be regarded as preventable.

6. The Influence of Complications.

(a) *Vascular.*—In a number of upper arm sutures of the median or ulnar nerves or both, where ligation of the brachial artery has been performed in the early days of the injury, there has been little appreciable effect on the rate and degree of recovery. Where contractures and other signs of ischaemia have coexisted and the total mechanical disability is naturally great, the clinical evidences of the recovery of the nerve have often been masked.

(b) *Non-union of Fractures.*—The continued existence of non-union of a fracture without active inflammatory signs in the neighbourhood of the recovering nerve has retarded or prevented recovery in two musculo-spiral sutures in my series; one showed a failure of distal regeneration after four years, and the other a total absence of any sign of recovery. These failures are to be attributed to the effect of tension and friction.

7. The Continuance of Active Interstitial Neuritis in the Proximal Nerve.

This is a potent cause of delay or failure, which theoretically is avoidable by a free resection preparatory to suture. But it is certain that histological evidence of interstitial change may often be present in the proximal part of the nerve trunk when there is little or no macroscopical sign of its existence. Where there has been a long delay owing to the presence of inveterate sepsis in the limb, the interstitial neuritis finds its maximum

development. In my own operations complete failure or imperfections in recovery have been dependent on this factor, and particularly in the sciatic nerve, where the ill effects are manifested during the stage of tardy recovery by the development of the signs of irritation. In three cases, after a period of more than two years, the pain in the internal popliteal distribution is a most serious handicap to the patient and continues to defy every form of treatment. On the other hand, in one of the complete recoveries after musculo-spiral suture definite evidence of interstitial neuritis was seen in the proximal part of the nerve trunk at the time of operation, and, owing to the size of the gap, the suture was performed at a level which was considered far from ideal.

Qualitative Results of Nerve Suture.

It remains now to judge the results of these nerve sutures from a qualitative standpoint. In this estimation it is necessary first of all to eliminate from the total disability of the limb the contribution of the coexisting injuries of other tissues. But function dependent on a restoration of nerve conductivity alone is itself essentially complex. Success depends not merely on the simple restoration of adequate motor and sensory conduction, but on the development of co-ordination in the particular movements in which the efferent and afferent supply of the sutured nerves are concerned.

In the musculo-spiral sutures where full conductivity has been restored, and where recovered muscle groups have achieved considerable power, there has been as yet no perfect individual extension of the fingers, no synergic function in the extensor muscles of the wrist, and there is on the whole an imperfect control over the extensor muscles of the thumb.

In the median nerve poor function has been the rule, chiefly owing to the very limited sensory recovery. The helpless anaesthetic index finger, which is characteristic of most of these cases long after the operation, is a striking illustration of the importance in function of a restoration of the median sensory mechanism.

In the ulnar nerve, where there is often a mobile hand without contractures, the gross function is little diminished even in the presence of a complete syndrome of interruption, and full restoration is of little moment except for the skilled worker. To many of these hands the addition of conductivity in the ulnar nerve has made little or no difference in function.

The full sciatic syndrome in itself does not cause gross loss of function in the lower limb as regards the act of walking. It is difficult to estimate the increased value of the motor recovery, which at the best has been moderate power in the calf and a less complete and powerful action in certain muscles of the extensor group.

RESULTS OF THE OPERATION OF NEUROLYSIS.

Whilst it is possible to study the results of end-to-end sutures in a truly mathematical fashion, a scrutiny of the results of the operation of neurolysis is beset with many difficulties. It will be sufficient to reiterate and amplify from a consideration of the results in 80 cases what is regarded in my opinion as the legitimate scope of this operation.

In the results are seen both recoveries, partial and complete, and complete failures. There have been no rapid recoveries within the period of nerve regeneration, for the type of lesion in which this might have occurred has not been explored. Where recovery has been seen it has been on the conventional lines of the ordinary regeneration as regards time and general progress. A certain number of operations have been premature explorations for lesions of a low grade, in which spontaneous regeneration was at the time proceeding. Where failure of recovery has occurred the intraneural changes have been of such a nature and extent as to inhibit the down growth of regenerating axons, and the extraneural operation has failed to alter the intraneural conditions. Whilst improvement has occurred in the neurological syndrome after the operation of neurolysis in 75 per cent. of cases, it has been impossible to prove that the operation itself alone has determined this.

For these reasons I would urge that the limitations of the operation of neurolysis as a definitive factor in the surgical treatment of the warfare lesions of nerves are to be fully realized.

RESULTS OF OPERATIONS FOR CAUSALGIA.

My series includes 25 operations performed for severe causalgic manifestations, 14 on the median nerve, 10 on the sciatic nerve, and 1 on the internal popliteal nerve.

1. The median operations consisted of (a) resection and suture on eleven occasions (twice on the same nerve); (b) neurolysis on two occasions, and (c) one intraneural injection of quinine and urea. Of the resection and suture operations complete relief of pain followed immediately in nine; the pain was lessened but persisted indefinitely in the two resections performed in the same nerve in one patient. In this case there existed a grave contracture and a useless congealed hand when the man was first seen: ultimately the limb came to amputation. The cause of failure was the persistence of intraneural fibrosis in the nerve trunk, and its upward spread for many inches proximal to the line of suture.

Both neurolysis operations failed to produce relief and early re-exploration was necessary: in each, resection and suture was carried out with complete success.

The one intraneural injection for a mild case of causalgia produced a moderate degree of relief, and the pain showed signs of diminution with ultimate disappearance in a few months.

2. The results of resection and suture of the sciatic nerve were as satisfactory as in the case of the median, judging by the immediate relief afforded, but during the recovery stage, in three cases, the return of severe irritation has been a disappointing experience. The cause of this is also to be attributed to the progressive intraneural fibrosis.

3. The one neurolysis operation performed on the internal popliteal nerve, for what appeared to be a true severe causalgia, was followed by immediate cessation of the pain. In this particular case a strong functional element was present, and it is not certain that true causalgia existed, although the symptoms were mimicked very closely.

In the exploration of a nerve which exhibits a condition of profound irritation, the hyper-excitability of the nerve trunk and the muscles supplied by it, both above and below the lesion, is a striking phenomenon.

The efficacy of the operation of early resection and suture for severe causalgia is beyond criticism. It would appear to be a more exact procedure than the equally or even more destructive method of alcohol injection. It has not been my experience to meet the type of case in which still more drastic procedures have been inevitable, such as section of the posterior roots.

The operation of Leriche, stripping of the periarthral sheath, is founded on an erroneous conception of the anatomical situation of the vasomotor fibres of the limb, and is to be mentioned merely for the sake of completeness.

GENERAL CONCLUSIONS ON THE LATE RESULTS OF NERVE OPERATIONS.

References have been made from time to time to the results quoted in other contributions to the literature of the peripheral nerve surgery of the war. From this literature, already vast, it has been impossible to collect and compare on any recognized standards the total statistics as to the late or end results of the various forms of operations. From a wide study of this literature, and an intensive study of my own material, it is possible merely to enunciate broad generalizations influenced in particular by the consideration of the causes of failure and success.

During the past year it has become increasingly difficult in this country, at any rate, to keep in touch with the patients who have been operated upon, even during the last two years. The chances of acquiring further comprehensive knowledge regarding true end-results would therefore seem to be slender. This is a bitter disappointment after the labours of a number of years. But, for some little time, a small stream of patients with nerve injuries still unoperated on, or showing failure after previous operation, will continue to flow into the surgical centres of the Pensions Ministry. Such patients, on the whole, are now undesirous of submitting to operative procedures. But the surgical lessons gained from the amount of experience behind us are yet to be applied for the benefit of a few. And it is of great economic importance that clear indications as to the advisability at this date of the exploration or re-exploration of the injured nerves should be laid down.

Every lesion will date back at least two years, so that the optimum period for the surgical repair of the nerve is now past. But for perhaps a year longer it will be worth while advising operation in selected cases. Before doing so, the economic value of the restoration of nerve conduction to the future capacity of the limb must be gauged. In many limbs an operation is now a waste of time. From a serious consideration of the problem as it presents itself at the time, it is suggested that the exploration or re-exploration should be considered under the following conditions:

1. In complete lesions of the median or ulnar nerves in the upper arm restoration of function in the proximal muscles is to be expected, even after long periods of delay, but distal recovery may probably not take place. For lesions of these nerves, in which conduction is already present as far as the proximal branches, with the total failure of distal regeneration, exploration is on the whole advisable; but suture and resection and suture, which may be unjustifiable, nothing can be done.

2. In complete lesions of the median and ulnar nerves in the forearm the potential restoration of sensation in the median is of such great importance as to warrant making every effort to ensure its occurrence. In lesions of the median in which partial sensory conduction is present, but with complete motor loss, resection and suture at this date should be strongly condemned. For the ulnar, where the intrinsic muscles are alone inactive, resection is always worth while.

3. In all complete sciatic lesions where end-to-end suture can be reasonably expected.

4. In musculo-spiral lesions exploration of the nerve should precede the performance of tendon transplantation.

ALTERNATIVE OPERATIONS.

Although a technical consideration of those alternative operations for the restoration of function where nerve repair has been deliberately abandoned, or has failed to ensure conduction or function, is outside the scope of the present study the question of the appropriate time and indications for their exhibition is one which is intimately concerned with the observations on the failures and successes of the suture operations.

Where the nerve lesion is declared to be irreparable after an exploratory operation, the indication for the performance of an alternative operation is clear. But in the case of imperfect function following the incomplete restoration of conduction the rôle of the alternative operation cannot be so readily defined. Many of the operations performed under the latter heading have been premature, and have been done early in the reconstructive surgery of the war when the normal prolonged stage of recovery of the injured or repaired nerve was not fully realized. The capacity for regeneration and ultimate function of the nerve after repair is apt to be minimized. Every surgeon who has lived close to this problem must have felt at times despondent. The immediate failures, or late failures, are easily explained, and many of the causes can be avoided. It is likely from what we have seen of the behaviour of the regenerating nerve that after long periods of time in a considerable number of instances there will be well marked recovery of function. It is to be admitted, on the other hand, that to wait for a future recovery of uncertain value is likely to be unsound. Again, the alternative operation itself may in no way jeopardize the recovery of the nerve, and therefore little harm can be done by its early performance. Few of the alternative operations have entered permanently into one's surgical repertoire. In the upper limb these are above all the now classical operation of tendon transplantation for irreparable musculo-spiral injuries, the results of which are extremely gratifying; the simple tendon transplantations for restoration of flexion of the fingers or thumb in median and ulnar injuries; and, in the lower limb, the destructive operation of tenodesis of the ankle as an alternative to the lifelong wearing of apparatus.

Recently a new procedure has been added to the alternative operations which belongs to peripheral nerve surgery itself. This is the implantation of the proximal end of the radial nerve into the median nerve at the wrist—an attempt to restore that lost sensory function in the median area which produces such a grave incapacity. This operation was introduced by Harris of Toronto, and is

supported by the report of one successful case. For the few irreparable lesions of the median nerve in the forearm this operation may be worth a trial.

REFERENCES.

- ¹ Stopford, *Brain*, May, 1920. ² Kennedy, *Lancet*, July 5th, 1919. ³ Leriche, *Presse Médicale*, April 20th, 1916. ⁴ Harris, *Journ. Orthop. Surg.*, September, 1920.

HERPES AND VARICELLA.

BY

E. H. R. HARRIES, M.D., B.S.LOND., D.P.H.,
MEDICAL SUPERINTENDENT, BIRMINGHAM CITY
HOSPITAL, LITTLE BROMWICH,

AND

EVELYN DUNDERDALE, M.B., CH.B. EDIN.,
ASSISTANT MEDICAL OFFICER, BIRMINGHAM CITY HOSPITAL,
LITTLE BROMWICH.

The following account of an outbreak of varicella in a ward, apparently originating in a case of herpes zoster, seems of sufficient interest to record.

W. G., female, aged 8 years, was admitted to a diphtheria ward on November 16th, 1920, suffering from a severe attack of that disease. Unfortunately she developed scarlet fever from another case admitted with diphtheria, who was also incubating scarlet fever. W. G. was transferred to a small ward, X, on the same day. Here were three other children, M. T., A. F., and L. Y. For administrative reasons these four children were moved on January 27th to a large ward, F., containing twenty-five beds and cots.

On February 4th, a week after transfer, W. G. developed what appeared to be a typical herpes zoster over the area supplied by the twelfth dorsal and first lumbar nerves on the left side. The distribution extended completely round the left side of the trunk, within the area indicated—that is to say, from the mid-line in front to the mid-line behind. The lesions were closely set and went through the usual changes of herpes zoster. As the question of the relationship of herpes and varicella was in our minds for investigation when opportunity should arise, a careful examination was made for scattered lesions elsewhere on the body, and none were found. The point that we should like to mention particularly is the fact that the child had absolutely no pain, either before or during the persistence of the lesions. Herpes zoster, of course, is commonly a painful affection. W. G. had no previous history of varicella and presented no scars of a former attack.

On February 17th—that is, thirteen days after—three children in the ward developed varicella; on the following day, the 18th, four more showed the typical lesions, and by February 27th another child had incubated the disease. The position of the children in the ward, their respective ages in years, and date of onset of varicella, were as follows:

South Side of Ward.		North Side of Ward.	
No. of Bed.		No. of Bed.	
1.	Died. S.F. and Diph.	14.	X. Aged 5.
2.	V.P. Aged 6.	15.	X. Aged 3½.
3.	V.P. Aged 5½.	16.	M. T. V. Aged 4.
4.	X. Aged 6.	17.	X. Aged 5.
5.	W. G. Aged 8. Herpes zoster.	18.	X. Aged 4.
	February 4th.	19.	A. F. V.P. Aged 6.
6.	L. Y. X. Aged 7.	20.	V. Aged 2½. February 17th.
7.	V.P. Aged 9.	21.	V. Aged 4. February 17th.
8.	V. Aged 7. February 27th.	22.	V. Aged 2. February 18th.
9.	V.P. Aged 7.	23.	V. Aged 5. February 18th.
10.	X. Aged 12.	24.	V.P. Aged 7.
11.	X. Aged 6.	25.	X. Aged 8.
12.	V. Aged 5. February 18th.		
13.	V. Aged 6. February 17th.		

V.P. = Varicella previously. X. = Exposed to infection.
V. = Exposed to infection and developed typical varicella.
L. Y., M. T., A. F. = three patients from Ward X.

No case of varicella had occurred in the hospital for some weeks previously, and certainly the case of herpes has not been exposed, as far as is known, to any risk of varicella infection. When W. G. developed herpes she had been in hospital about eleven weeks. There had not been a previous case of herpes zoster in the hospital for some months, and then it occurred in a ward far removed from W. G.'s, and, it should be noted, was not followed by varicella. W. G.'s herpes arose *de novo*. Did she originate the outbreak of varicella, or was there a missed case presenting only one or two lesions, the time relation ship being merely a coincidence?

Morphologically, W. G.'s lesions were typical of herpes zoster. She had no previous history of varicella, nor scars of a former attack, neither has she since developed varicella as a result of contact. The complete absence of pain or even of appreciable malaise are noteworthy. The incuba-

tion period of thirteen days is on the short side as compared with previous ward outbreaks of varicella in this hospital in the earlier part of last year. Previous outbreaks have had an incubation period of from seventeen to twenty-one days. The incubation period of varicella is of course very variable, and the present outbreak may be due to another strain of the virus. Varicella in this country is practically never fatal. The experience of one of us (E.H.R.H.) at a military infectious diseases hospital in Mesopotamia was that varicella in Indian troops and followers was very common and frequently severe, death from pulmonary complications being by no means unknown. Careful pathological investigation of such cases might lead to important information upon the etiology of the disease.

CHRONIC SUPPURATIVE OTITIS MEDIA:

FOLLOWED BY LEFT TEMPORO-SPHENOIDAL
ABSCESS AND MENINGITIS.

BY

F. HOLT DIGGLE, F.R.C.S.,

SURGEON-IN-CHARGE, AURAL SERVICE, ANCOATS HOSPITAL,
MANCHESTER.

The following case deserves recording by reason of (1) the presence of pus cells and bacteria in the cerebro-spinal fluid, and (2) the reaccumulation of pus in the brain after having been once successfully evacuated, with extensive paralysis and ultimate perfect recovery.

L. P., female, aged 23 years, was admitted to hospital on October 27th, 1920, in a drowsy condition, with a temperature of 101.6, pulse 82, respirations 20.

History.

The history was only obtainable from the patient, as she had no relatives or friends. When roused she stated that she had had ear trouble (doubtful on which side) since Christmas, 1919, the cause unknown. She had severe pain in the left side of the forehead and left temporal region in Whit week 1920, and visited a hospital in the district, obtaining some relief. The headache had been worse for the last three weeks.

Condition on Admission.

She was drowsy, but could be roused to answer questions. She was slightly aphasic, complained of headache on the left side of the head. She had vomited twice since admission.

Nervous System.—(a) Motor: There was slight weakness in the grip of the right hand, no other paresis or paralysis. The sphincters were normal. There was some rigidity of the neck muscles. (b) Sensory: There was nothing abnormal as far as one could ascertain in her drowsy state. (c) Reflexes: There was slight increase of the right knee-jerk. The right superficial abdominal reflex was brisk. No ankle clonus or Babinski reflex was present. (d) Eyes: The pupils were dilated, equal, reacting to light. The discs were not examined. There was no nystagmus, no photophobia. There was marked loss of the naming centre.

Ears.—The right membrane had a small central perforation with a viscid purulent discharge. The left had marked meatal stenosis, a large vascular polypus obstructing the already narrow meatus. There was no visible otorrhoea. There was no tenderness or oedema over the mastoid processes, no pain on percussion of the cranium. The tissues of the neck were normal.

Lumbar Puncture.—There was positive pressure and a cloudy cerebro-spinal fluid. (See pathologist's report below.)

Operation (October 27th, 1920).

A radical mastoid operation was performed on the left side. The mastoid antrum was full of pus under great pressure, and very foul. The dura mater of the middle fossa, exposed by disease, was covered with granulations bulging and pulsating, and the middle ear was full of granulations. The lateral sinus and dura mater of the posterior fossa, exposed by chisel, were found to be healthy. The remains of the tegmen tympani with a portion of the squamous portion of the temporal bone were removed, and the left temporal lobe was explored. A large abscess containing very foul pus was evacuated and drained by two rubber tubes side by side (diameter ½ inch). The auricle was stitched forward and a buttress built around the margin of the wound with gauze so as to avoid pressure on the tubes.

Pathologist's Report (Dr. Renshaw).

Cerebro-spinal fluid: Pus cells were present. A large number of Gram-negative diplococci were in the film (*Diplococcus mucosus*), present in culture, also in agar, in large numbers.

Pus from brain abscess: Staphylococci and streptococci were present in pus in large numbers, and some long thin curved Gram-negative bacilli (anaerobes). Necrotic debris was present, but very few pus cells. Later, *Diplococcus mucosus* was found in a culture of the brain pus.

After-History and Treatment.

Urotropin gr. x four-hourly was given for the first forty-eight hours, and then three times a day. The outer dressing was changed daily after twenty-four hours and the mastoid cavity irrigated, the brain cavity draining fairly well.

November 2nd, 1920. Mentally the patient was greatly improved, temperature 99.6, pulse 110, respirations 22. The wound was very foul. Tubes were removed, followed by a copious discharge of pus. The abscess cavity was gently irrigated, and the tubes replaced.

November 6th, 1920. Mentally the patient was good, taking her food well. Temperature and pulse were normal. The wound was cleaner, and the tubes being naturally expelled, were shortened.

November 11th, 1920. The patient's temperature was 101, pulse 100, respirations 18. The wound was looking very clean. The patient appeared very well and had no complaint. The tubes had been expelled two days ago. There was an oedematous-looking bulging of the brain, into which sinus forceps were gently inserted, but only a few drops of a clear fluid were evacuated. In the evening the patient suddenly became unconscious and completely paralysed on the right side, with severe headache (band to left side of head), temperature 101, pulse 116, respirations 18, pupils dilated, the right side of the face immobile, and the face cyanotic. The sinus forceps were inserted into the brain cavity, and at first clotted blood was evacuated, but at a depth of 2½ in. (upwards, forwards, and slightly inwards from the tegmen atri) a copious discharge of pus and gas was evacuated. A tube would not remain *in situ*, so the oedematous hernia cerebri was excised flush with the tegmen, and the cavity was lightly packed with gauze.

The patient made a slow uninterrupted recovery. The temperature gradually subsided after reaching 103.8 on November 15th, and was normal by November 21st, remaining so. An extensive hernia cerebri, dressed with green protective, drained well and gradually subsided without any lumbar puncture being performed. The paralysis gradually improved. On February 11th, 1921, the patient walked normally, there was no sign of any paresis, the wound was healed, the ear dry, and she was mentally well. On being seen on March 6th, 1921, the patient was very well and mentally sound.

In conclusion, I wish to draw attention to the following:

(1) No tenderness, pain, or oedema over the mastoid, by no means uncommon. (2) Exposed dura mater was pulsating well (a pre-operative lumbar puncture performed). (3) Lumbar puncture was never employed therapeutically throughout the course of the disease.

As an explanation of the sudden onset of coma on November 11th, 1920, I would suggest that the septic focus still present in the brain had ulcerated through a blood vessel, producing a sudden haemorrhage with compression and hemiplegia (clot was first evacuated from the second brain abscess cavity). Naturally my first impression was that the abscess had ruptured into the lateral cerebral ventricle, a supposition which is, I think, untenable having regard to the subsequent progress of the case.

Memoranda:**MEDICAL, SURGICAL, OBSTETRICAL.****ENCEPHALITIS LETHARGICA TREATED WITH INFLUENZA BACILLUS ANTIGEN.**

In the BRITISH MEDICAL JOURNAL of March 27th, 1920, one of us (W. M. C.) related the histories of four cases of lethargy treated successfully with pure influenza antigen (vaccine). The paper has apparently received little attention, since recent literature reveals no ideas as to the nature of the infection, much less does it reveal any successful line of treatment. We think it, therefore, desirable to relate the following case, the treatment of which with pure influenza antigen was just as dramatically successful as that of No. III of the other cases previously recorded.

The patient, a girl aged 5 years, living in the South of Ireland, was taken ill on February 18th, 1921, with slurring, drowsiness and headache most intense behind her eyes. She was seen by D. C. on February 21st, when her temperature was 102.6 F., the pulse 120. She was asleep, and could only be roused with difficulty; when the eyes were open the conjunctivae were seen to be injected—the typical pink eye of influenza. She was very constipated, necessitating enema, but she had not incontinence of urine. There was a watery discharge from the nose. She had muscle twitchings—very marked in the eyelids. When roused she answered questions slowly but intelligently, but was profoundly asleep again within a few minutes. Her temperature fell to 99 F. and her pulse to 95 by February 24th, but the lethargy seemed to increase, the patient only being awake when roused

to take food. W. M. C. was then consulted, and 1½ million *I. influenzae* antigen were given on the morning of March 2nd under the skin of the hip; her temperature was then 99 and the pulse 95. She was asleep again a short time after the injection. At the end of six hours she woke up quite bright and cheerful; the temperature had fallen to 97.4 and the pulse to 76. She remained awake four hours. On March 4th she remained awake from 9 a.m. to 6 p.m. The drowsiness then gradually increased again until, on March 10th, she was given 2½ million. She slept for three hours and woke up bright and gay. Next day, however (March 11th), a reaction appeared. She slept a good deal. She complained of headache. The temperature rose to 99.4 F., the pulse to 115. The discharge from the nose came on again, and the conjunctivae were injected. These symptoms had passed away by the next day, and she has remained normal in every way ever since. She has been given a few more increasing doses of antigen.

The rapid relief after the first dose, just as significant diagnostically as the focal and general reaction after the second dose, makes it certain to our minds that the influenza bacillus was the causative microbe. Unfortunately, owing to the distance from a laboratory, no satisfactory bacteriological examination of the nasal discharge could be made, and it was not attempted.

The antigen used was made from a recent growth on human blood agar and was not killed by heat, so that nothing was done which would in any way reduce its toxicity, and therefore its potency as an antigen.

W. M. CROFTON, M.D.

D. COSTELLO, M.B.

Dublin.

ARTIFICIAL RESPIRATION IN THE NEWBORN.

THE method of artificial respiration here described has, in my experience, proved more certain and effective than any method now in vogue. It is, as will readily be understood, only applicable in the case of infants. I was led to elaborate it by noticing that a child who had inhaled liquor amnii, and was held head downwards in order to free the respiratory passages, emitted a sigh when the abdominal contents pressed on the diaphragm. This led me to reverse the position of the infant to allow the lungs to expand.

The infant is held in the following way: The back of the neck lies on the palmar surface of the left hand, the occiput being supported in the hollow between the thumb and forefinger which grasp the mastoids. The right hand holds firmly both ankles of the infant from behind, so that the ulnar side is on the calves, the radial side at the heels. The infant is held with its long axis nearly vertical, at an angle of about 15 degrees, head upwards, and is then allowed to move quickly downwards by its own weight some two feet. The abdominal viscera fall towards the pelvis, the diaphragm is depressed at inspiration initiated. The infant is now lifted, feet first, to the right of the operator, so that it is now held downwards at an angle of 15 degrees to the vertical. It is again moved smartly downwards, head first, about two feet. The abdominal viscera, falling against the diaphragm, expel air from the lungs equivalent to expiration. This movement, at least to some extent, must also act as massage of the heart and so be a direct stimulant. The whole cycle is repeated about fifteen times to the minute, and the first movement will often elicit a sigh if not a more pronounced response. Needless to say all semblance of violence must be avoided.

Harrogate.

W. OSFOURNE GREENWOOD, M.D., B.S.

OLIVE OIL, SOFT SOAP AS A SHAMPOO IN PITYRIASIS CAPITIS.

THE exceedingly common affection called pityriasis capitis or dandruff is often unsuccessfully treated by the general practitioner owing to neglect of the great essential of systematic shampooing at regular intervals, and with the much advertised use of "shampoo powders" this disease is aggravated, especially in childhood, whereas if the scalp disease was cured in early life there would be no kindred eruptions of the face and trunk in adult life. The great advantage of olive oil soft soap as a shampoo is, first, that it acts as an antiseptic, thereby rendering the organism, which is confined to the superficial layers of the epidermis, and which is responsible for the disease, inactive; secondly, the solvent and stimulating action is less irritating than that of ordinary soft soap. The scalp should be shampooed regularly once a week in bad cases.

The soap is dissolved in hot water till a thick lather is obtained, with which the scalp is thoroughly rubbed. After shampooing rinse with plain warm water.

London, S.W.11.

K. WORSLEY POOLF, M.D.

CONGENITAL DEFICIENCY OF THE DIAPHRAGM.

THE following case seems worthy of record inasmuch as congenital muscular deficiency accounts only for some 10 per cent. of diaphragmatic herniae, and in this case the strangulation was not in the original sac, but in a diverticulum from it.

A child, aged 8 months, had been perfectly healthy until three days before admission to the Preston Royal Infirmary, when it commenced to vomit and the abdomen became gradually distended. There had been absolute constipation.

On examination after admission, the pulse was rapid and feeble, the lips were cyanosed, and the abdomen was very considerably distended, hard and drumlike, but nothing was palpable. *Per rectum*, the abdominal contents were bulging with the anterior rectal wall, otherwise there was nothing of note.

Laparotomy was immediately performed and the small bowel and ascending colon were found to be distended, while the descending colon was collapsed. The stomach was lying well up in the left side of the thorax, where there was apparent absence of the left dome of the diaphragm. The transverse colon had passed up beyond the stomach into a further sac and had become obstructed. The large bowel was reduced by the division of the constricting band, and the abdominal cavity was rapidly closed. Unfortunately, the patient, who was in a condition of profound toxæmia, survived the operation by a few minutes only.

On *post-mortem* examination there was found congenital deficiency of the left dome of the diaphragm; the left crus was present, and from it a few fibres passed round the left side of the oesophagus to join the anterior parietes slightly to the left of the middle line. Through the deficiency the peritoneum bulged into the thorax, where it was in direct contact with the basal pleura, the cardiac portion of the stomach reaching as high as the third costal interspace. At the apex of this sac the pleuro-peritoneal lining had given way to form a further sac in which the transverse colon had become strangulated. The heart was found lying completely to the right of the middle line. The left lung was collapsed and had apparently never functioned; it sank on being placed in water.

When the mother was questioned she recalled that there had been at times a bulging of the lower part of the left side of the thorax after feeds. I am indebted to Dr. Healey, honorary visiting surgeon, for permission to publish these notes.

GEORGE S. BARNETT, M.B., Ch.B. Edin.,
House Physician.

Preston Royal Infirmary.

Reports of Societies.

PRURITUS ANI.

At a meeting of the Subsection of Proctology of the Royal Society of Medicine on April 13th, with the President, Mr. W. E. MILES, in the chair, a discussion took place on pruritus ani, its causation and treatment.

Mr. J. P. LOCKHART-MUMMERY distinguished five groups of pruritus ani: (1) due to a general condition, such as glycosuria; (2) due to parasites; (3) secondary to some lesion of the anal region; (4) of old standing, with no local lesion discoverable; (5) paroxysmal pruritus. When a definite cause for the pruritus was discovered it was generally found to be one which produced a certain amount of moisture of a septic character, such as an ulcer. The removal of this, if the itching was of recent onset, gave permanent relief. Cases with a history dating back for more than two years were very difficult to cure, and even when a local lesion was discovered its removal seldom stopped the itching. He believed the change which took place in such long-standing cases to be fibrosis of the deeper layer of the skin, involving the nerve endings, and that it was brought about by a constant scratching and rubbing of the part. In 1912 Dwight Murray in America put forward the theory of a chronic streptococcal infection of the anal region, and the speaker believed this theory to be properly established. The first point in local treatment was strict attention to cleanliness and dryness. Powders

were better than ointments or greasy applications. If a local lesion—such as piles or ulcer—was discovered, it should be removed, and if such a lesion was not discovered the patient should be put under an anaesthetic and a complete examination made. X rays, applied with suitable screens, would cure about 20 per cent. of the bad cases, and the cure was generally permanent; two or three applications were usually sufficient. He had seen some very bad burns, and in one case an epithelioma of the anus, result from X-ray treatment. When further measures were necessary there remained the operation first described by Sir Charles Ball in the BRITISH MEDICAL JOURNAL of January 21st, 1905. Ball's operation proved most satisfactory, but it was essential that the whole of the irritable area of the skin should be anaesthetized; the failures attributed to the operation were often due to missing some of the nerves. In performing the operation care must be taken to free the lining of the anal canal. The operation gave immediate relief and left no disability. Normal sensation returned completely within about six weeks. He had performed this operation in 59 cases. There had been a slight recurrence of itching in seven; in four of these this was cured by simple applications, and in the other three the operation was repeated, with complete success.

DR. ARTHUR WHITFIELD said that a very large number of cases in adults—even middle-aged adults—were due to the oxyuris. The profession as a whole was not alive to the fact that threadworms were really very common. In one case, made temporarily quiet two years ago by X rays, the patient recently returned with a recurrence, and before recommencing treatment, he insisted that the patient should have thymol; on this being given, a large number of threadworms were produced. Cases almost always relapsed after X-ray treatment, and repeated doses lost their beneficial effect. When an obvious lesion was found and removed, a single dose of X rays might be useful. He believed that a great many burns and atrophies resulted from X rays. The most extravagant atrophy could be produced two years after the last dose had been given, even though no one of the doses had produced the smallest erythema or dermatitis. Among local applications greases should be avoided; lanoline was the worst grease that could be used, on account of its extreme tenacity and stickiness. He added that in a number of cases he had got the streptococcus from the anal tissue.

DR. J. M. H. MACLEOD said that there were mild cases of pruritus ani which lasted a considerable time, and were due to causes of less importance than polypi or the presence of oxyuris in the rectum. Pruritus of a very troublesome character could be caused by congestion in the liver. A good many cases were due to general cutaneous affections. One case sent to him as pruritus ani proved, on examination, to be a case of psoriasis, with psoriatic patches on the knees and scalp. Another cause not to be lost sight of was ringworm, which was extremely common about the anal region. He had seen a couple of cases within the last year, sent to him as pruritus ani, which had the ringworm fungus. The rubbing and scratching caused secondary changes, sometimes a very marked thickening of the epidermis, and possibly the thickened epidermis pressed on the nerve endings and caused the spasms of pain which were so often found. He was not entirely favourable to X rays, but he had had a certain number of cases which did excellently, without recurrence so far as he knew. He gave usually three half-pastille doses, well spaced out.

SIR CHARTERS SYMONDS said that, local complications apart, the real basis of the trouble was a septic condition, and therefore he insisted on the utmost cleanliness and dryness after defaecation, and also wearing of some absorbent wool—salicylic wool had a special virtue—which must be frequently changed to prevent friction and diminish the evil effects of moisture. He thought the best remedies to be silver preparations, not nitrate of silver, but argyrol and protargol in 10 or 20 per cent. solutions.

DR. N. S. FINZI said that before the cases came to the radiologist they should be investigated by a competent proctologist. Unless the cause was removed, the symptoms were bound to recur. When the cause had been removed or no definite cause had been found and the irritation continued, he thought that the theory of infection of the skin with the *Streptococcus faecalis* was very likely to hold good in such cases, and that here the treatment by

local measures such as x rays would be a sound proceeding. His experience was that cases were nearly always relieved by x rays at the commencement, but x rays could not be continued indefinitely. His results with radium had been rather more permanent than with x rays, although very similar otherwise. He had only used screened radium rays. If he was given the choice, and the irritation was not over too wide an area, he would prefer radium. He gave his doses of radium at intervals of six weeks, and he liked to give one further application after the disease had disappeared. There was still another procedure available for obstinate cases, supposing the patient refused to submit to Ball's operation, and that was the use of high frequency, applied with a vacuum electrode; in some cases this had a remarkable effect.

Sir CHARLES GORDON-WATSON said that there was one type of pruritus ani which he was inclined to regard not as surgical but as medical, like the pruritus associated with general constitutional diseases—namely, the pruritus occurring in the neurasthenic type of person. In such cases there seemed to be a strong hereditary tendency. In one case of father and son, both of whom were suffering from pruritus ani, he examined the son and found the dermatitis negligible and the anal canal perfectly healthy, with none of the fissures, ulcers, and haemorrhoids familiar in surgical cases. The surgical cases, he thought, ought to be divided into those which had an actual cause in the anus and those which had no marked disease or disturbance of the anus. When the cause was removed, if the pruritus had been only of short standing, the case could be cured for a certainty. In such cases ionization was of service, provided that all the elasticity of the skin had not disappeared. If the skin had not been changed into a kind of fibrous tissue but was still pliable, the cases responded well to ionization. In 28 cases treated by ionization (mostly zinc, but occasionally copper as well) every one experienced very great relief after the first treatment, and some needed no further treatment, though others went on to six or seven applications. Cases of paroxysmal pruritus were often to be referred to the neurasthenic class, but others were undoubtedly due to hypertrophied papillae. He had records at St. Bartholomew's Hospital extending over eighteen months of 86 cases of pruritus ani, in 53 of which there was one or more visible papillae. In the cases in which nothing was found but papillae the cautery was used, and in the majority a cure was obtained, in some cases certainly permanent after one application.

Mr. ASLETT BALDWIN said that when local conditions had all been excluded, the bowel should be examined by the sigmoidoscope. Many of these cases had a catarrhal condition of the bowel, and that was the cause of the chronic dampness of the anus. He had seen many cases relieved by ionization with zinc sulphate. Dr. W. M. FELDMAN also suggested a catarrhal condition of the bowel as the cause. The condition appeared to be hereditary; at least he had one patient whose father suffered from pruritus ani in a mild degree and whose maternal grandmother had pruritus vulvae in a severe degree.

Dr. FRANK COKE referred to work on protein sensitization, and said that in recent American literature he found two cases tested by skin tests, one giving a big reaction to potato and the other to pork, and on removing these articles from the diet or returning the patient to it, the condition disappeared or reappeared accordingly.

The PRESIDENT (Mr. Miles) thought that the term "pruritus ani" was unfortunate, because it signified nothing beyond the fact of itching. They should discriminate between a purely local condition—that is, a local dermatitis—and a dermatitis which, although it might occur in the perineal region, was part of another disease, such as psoriasis or eczema. He had always considered the chief cause of pruritus to be dampness of the perineal region and this he attributed to the hypertrophied glandular elements in the skin of that region. An analogous condition was hyperidrosis of the feet, which set up into digital itching. The treatment was careful drying. Dampness by macerating the skin gave opportunity for bacterial absorption. Hypertrophied papillae existed in the majority of cases of pruritus ani. One of the most productive causes of the condition was rectal constipation; when the faecal material was passing through the anal canal these hypertrophied papillae produced a spasm which cut off the act of defaecation and

left a certain amount in the bowel. A very large proportion of cases could be cured by (1) drying the anal region with suitable powders, (2) ensuring that when the patient went to bed he did not go with a full rectum.

Mr. LOCKHART-MUMMERY, in reply, agreed that the anal papillae were often the cause of the trouble. As for sex incidence, the condition was rather more prevalent in men, but there was no great difference. He had tried vaccines, both autogenous and stock, and found them of no use.

ALTERATION OF PRESENTATION AND POSITIONS IN LABOUR.

The Glasgow Obstetrical Society met on March 16th, when Dr. ROBERT JARDINE gave a dissertation on "Methods of altering the presentation and positions before and during labour."

The operations were, he said, most frequently performed in the interests of the child, but were also often applied to facilitate labour and to spare the mother. He advocated examination a few days before labour to determine the position, which was then, as a rule, the same as that assumed during labour, if secondary face cases were excluded. Spontaneous alteration of position was very unusual at that late stage of the pregnancy, although not unknown. A transverse position found at such an examination should always be turned by external manipulations into a vertex or breech. In a primipara the external version should always be to a vertex, and this should be practised when a breech was found in a primipara. He had never tried to alter an occipito-posterior position to an occipito-anterior by external manipulations prior to the onset of labour, although this was possible. He made a plea for the more extensive use of abdominal palpation.

In occipito-posterior positions he did not approve of the rotation of the head by forceps, as he contended that the head was twisted on the neck while the shoulders were not turned. The treatment he advocated was manual rotation, aided by the external hand pushing the shoulder across, or, if this did not avail, the fingers of the vaginal hand were extended past the head, and the shoulder having been gripped, rotation was accomplished in this way. Rotation completed, he felt that it was advisable to apply forceps forthwith. Such cases ought not to be allowed to continue too long in labour. If the head was well flexed Milne Murray's straight axis-traction forceps, twice applied, were often satisfactory. In persistent occipito-posterior positions he advised attempt at rotation, trying first to one side, then to the other, on failure of which forceps delivery with the face to the pubis should be attempted despite the possibilities of perineal lacerations.

In face presentations it was advisable to leave all mento-anterior positions, except in cases where the head was very large, where it was advisable to convert to a vertex, at the same time rotating the occiput anteriorly. In all mento-posterior cases he thought that interference was justified. With a fully dilated os and unruptured membranes it was advisable to flex the head by manipulation *per vaginam*, and in cases with ruptured membranes manual dilatation of the os and flexion of the head was desirable before the face could become impacted. He advised immediate delivery with forceps after this manoeuvre. All these he had found easy to perform except in primary face presentations, in which he considered version the line of treatment to be adopted. Persistent mento-posterior positions could only be delivered as such if the child was very small. Attempts could be made to push the head up in these cases and perform flexion, but failing this craniotomy was to be recommended.

The typical parietal presentations of flat pelvis were interesting. The anterior parietal positions he left to mould, and then delivered with axis-traction forceps in Walcher's hanging leg position. The posterior parietal positions, fortunately the less common, presented a greater difficulty. These could be converted to anterior parietal presentations if got early and before moulding, but were difficult to maintain in the new position. Delivery by forceps immediately on correction, if possible, was the best method of treatment. If the correction could not be maintained he advised version.

Transverse presentations with ruptured membranes were treated, with fully dilated os, by performing podalic

version; in back anterior cases the lower leg was taken, while in back posterior cases the leg to be taken was the higher one, thus bringing the dorsum anterior for the completion of the delivery. In cases attended by retraction and impaction decapitation was the correct treatment.

In cases of breech presentations with extended legs he felt that the delay was due not to the splint-like action, but to the presence of a retraction ring. The hand was to be forced gently past this, a leg swept inwards, and the child delivered by the application of *vis a tergo*.

At the conclusion of Dr. Jardine's address Dr. W. D. MACFARLANE read a communication on "Caesarean section as a method of treatment in central placenta praevia."

CAESAREAN SECTION.

At the meeting of this Society on March 23rd Professor J. M. MUNRO KERR introduced a discussion on "The indications, limitations, and technique of Caesarean section."

A marked disproportion between head and pelvis and pelvic obstruction due to fibromyomatous or other tumour were, he stated, accepted as definite indications for Caesarean section. The advisability of its application in placenta praevia, eclampsia, toxæmia of the late months, cicatricial conditions of the vagina, congenital narrowing thereof, and delayed labour in elderly primiparæ, was a debatable question until such time as surgical science could guarantee a sound uterine scar. The enlightened obstetrician would not be satisfied by sterilizing his patient, but would aim at the perfection of the scar, and to succeed in this he would have to give more careful consideration to such details as the suturing of the uterine wound, suture material, and, above all, the choice of a site in the uterine wall where the scar would be subjected to a minimum of strain. He referred to Dr. Eardley Holland's communication to the Royal Society of Medicine, and mentioned as of special interest the figures then submitted by Drs. Lindsay and Hewitt of the Glasgow Royal Maternity Hospital. From a review of ninety-four cases of Caesarean section, all unsterilized, they concluded that the liability to rupture in a succeeding pregnancy was 5.5 per cent., and that rupture occurred in 1.8 per cent.

The percentage of ruptures in a succeeding pregnancy could be reduced, he thought, but not in cases where the usual longitudinal incision was used. His reasons for not trusting to this incision were, first, that it was impossible to guarantee absolute asepsis; second, that during the puerperium the uterine muscle was in a state of autolysis, and thus interfered with healing; third, that the rough surface of the incised uterus did not approximate well, and permitted the collection of blood in small pockets thus formed; fourth, that the continual contraction and retraction of the uterus stretched the stitches, again permitting this pocket formation and blood collection. The necessity for the uterine sutures acting both as coaptors and haemostatic agents was another unsatisfactory state of affairs; they did not act efficiently in the latter capacity, failed to produce haemostasis, and healing was consequently imperfect. Above all, he attributed the weakness of the scar to the necessity to negotiate, at the first operation, a placenta placed anteriorly. In this condition the tissues were friable and over-vascular, the coaptation of the edges was particularly difficult, and blood collected between the stitch edges, with the result that a gutter formed on the inner surface of the uterus. In a subsequent pregnancy the membranes bulged into this gutter, formed a hernia, and ultimately led to rupture. These factors, he submitted, militated against the production of a reliable uterine cicatrix. He felt that the usual uterine scar could be improved; this could be done by such measures as practising prevention of sepsis, delivery of placenta *per vaginam*, to prevent the cervical portion of the membranes causing contamination; the operation should be performed at the most favourable time—for instance, at fairly full dilatation of the os in cases of contracted pelvis, or before labour in obstructive tumours; careful uterine suturing should be carried out, preferably in layers, catgut under the surface, fine silk or linen for the bulk of the muscle, and continuous catgut for the peritoneal surface, suturing during retraction, not contraction; there should be minimal massage of the uterus, and Fowler's position should be

employed during the puerperium, as recommended by Martin of Glasgow.

An alternative method of Caesarean section, giving, in his opinion, a more satisfactory scar, was the lower uterine segment operation. In this procedure the abdomen was opened in the mid-line and the uterus exposed, a transverse incision was made through the uterine peritoneum just above the bladder, which was then pushed down. A transverse incision was made in the lower uterine segment, stay sutures inserted at each end of it, and the child delivered. The wound was then closed, with catgut suturing for the mucous membrane, linen for the muscle, and catgut for tacking back the bladder. The cicatrix resulting was, he maintained, less liable to rupture. The advantages of this method were that, cutting through a less vascular area the haemorrhage was less, the cut surfaces were thin, and therefore more easily approximated with accuracy; these parts were at rest during the early days of the puerperium, and thus healing was facilitated; finally, the scar was not subjected to strain until the labour was far advanced. He noted also the infrequency with which one encountered the placenta in this area. In conclusion, Professor Munro Kerr submitted that this method was a promising one for the formation of a more reliable scar, and said he felt hopeful that it would ultimately produce a cicatrix which could be thoroughly relied upon to resist the strain of a subsequent pregnancy and labour. Already in four cases the scar had stood this test.

Dr. DAVID SHANNON expressed the opinion that conservative Caesarean section was performed too frequently and without due consideration to the weakened uterus which resulted therefrom. The lower uterine segment method offered a means of producing a safer scar. He had had the opportunity of examining the lower uterine segment after a normal delivery succeeding this operation, performed some time previously by Dr. Kerr, and had found no trace of scar. He himself had performed the operation on twelve occasions with very satisfactory results; five of these cases had been extensively and frequently examined before admission to hospital. He felt that there was scope for the operation in those cases which were suspected of being infected, which were, as a rule, terminated by that deplorable operation, craniotomy on a living child, with its attendant grave maternal mortality and morbidity. He had not experienced any difficulty in the operation, and had in one of his cases delivered a 10 lb. child.

Dr. J. NIGEL STARK explained that his experience of Caesarean section was confined to the conservative operation, and the results, immediate and remote, had been satisfactory. There were objections to the lower uterine segment operation, on account of the tendency to tear laterally in the case of a large child or a malposition, and on the score of the proximity of the uterine wound to the infected vaginal canal and cervix. A placenta encountered during this operation would be a serious difficulty.

Dr. DOUGLAS M. LINDSAY had assisted at several lower uterine segment operations, and only once had he noted difficulty. In this case no stay sutures were inserted at the lateral extremities of the uterine wound, and a tear into the right side of the cervix resulted with haemorrhage difficult to control. The investigation made by him in conjunction with Dr. Hewitt had proved that on occasion a thoroughly sound scar could follow the conservative operation. In that investigation there were examples of normal deliveries, forceps deliveries, and craniotomies in pregnancies following Caesarean section.

Dr. HEWITT referred to one particular case of that series. The patient's first child had been delivered by Caesarean section, her second was a seven months child delivered by forceps, her third was a breech delivery at term, complicated by extended legs, and when she again reached term she was delivered again by Caesarean section. He alluded to the variation in the thickness of the scar noted at the second operation and to the presence of adhesions. In one case he had had to cut a thick vascular band binding the uterus to the anterior abdominal wall.

Dr. R. A. LENNIE mentioned repeated Caesarean sections, some of which exhibited no sign of scar and some the guttering described by Dr. Kerr. He would fear trouble in cases of large children being delivered through the limited incision possible in the lower uterine segment. Referring to suture material, he quoted two cases in which a stitch sinus had followed two years after Caesarean section. In both cases the material had been

silk, and in a third case he had removed seven inches of silk *per vaginam* eighteen months after Caesarean section. He preferred three silk sutures with a deep and superficial catgut.

Dr. HENDRY had realized the advisability of allowing labour to proceed far in order to have the lower uterine segment well developed. This made the operation more an emergency one than the conservative method, and solved the difficulty of the delivery of a large head. In one case he encountered a breech and his difficulty had been in deciding upon the size of incision to be made. It was advisable to deliver the uterus entirely from the abdomen to permit a hand being placed on the posterior cervical wall to aid the delivery of the head.

Dr. W. D. MACFARLANE expected that in "clean" cases the results following conservative Caesarean section would be as satisfactory as with the lower uterine segment method, while in "suspect" cases he thought the latter operation less satisfactory than Caesarean hysterectomy. As chairman he thanked Professor Kerr for his excellent and suggestive paper, and expressed the hope that at some future date further records of the new method would be submitted.

NAEVI IN CHILDREN.

At the meeting of the Harveian Society on April 14th a lecture was given by Mr. DUNCAN FITZWILLIAMS on "Naevi in children, and their treatment," illustrated by many photographs and sketches.

Mr. Fitzwilliams said that he had careful notes of 700 cases, and that he must have seen 300 other cases of which he had no notes or only fragmentary ones. He defined a naevus as a blood-vessel tumour—just as much a tumour as a chondroma—which spread by the capillaries. Of his recorded cases, 56 per cent. were superficial, 35 per cent. transitional, and 8 or 9 per cent. subcutaneous. The number of deep naevi was, of course, difficult to estimate, for they were found in the viscera and in organs, where they must remain undiscovered during life. Naevi occurred twice as frequently in girls as in boys. It might be thought that the relatively high female incidence in the cases coming for treatment was due to the greater solicitude of the parents for appearance in the case of a girl, but he did not believe that such solicitude had any sex distinction in the case of infants so young. It was said that naevi were either present at birth or appeared during the first year of life; his experience, based on 645 cases, was that naevi were present at birth in 83 per cent., appeared in the first six months in 13 per cent., and appeared at a later date in 4 per cent. Very often when it was said that a naevus only appeared after birth, the fact was that it had not been mentioned by the nurse and had escaped the attention of the mother until she herself came to tend her offspring. Naevi occurred on the head and neck in 49 per cent. of his cases; on the trunk in 29 per cent., and on the limbs in 21 per cent. The long axis of the naevus was found always to lie in the same direction as the nerve supplying the part.

If naevi were left to themselves he believed that some disappeared. In certain cases they would disappear by ulceration, while others ulcerated but did not quite disappear, leaving a spreading line of red capillaries. The cutaneous naevus should be treated without delay as soon as it was seen. If purely in the skin, it might be destroyed by CO₂ (carbon dioxide snow), being washed first with a little ether or iodine, and then subjected to the pressure of the snow pencil for thirty or forty seconds. If it was too big to be thus treated in one application the snow must be applied at more than one point, but care must be taken that the freezing areas did not overlap, and that they had unfrozen areas between them, if undue inflammation and scarring were to be avoided. Excision was of equal value to CO₂. An elliptical incision was made at right angles to the skin and into the subcutaneous tissue; the knife should never touch the naevoid tissue itself, or the bleeding, coming from spaces and not from vessels, would be difficult to control. Electricity was not very suitable for these cutaneous cases, and left more scarring than was necessary. In the transitional and subcutaneous type excision was the best method to adopt wherever possible, permitting removal of the tumour in one operation. The next best method was the use of the cautery, care being taken to destroy the growing edge of the naevus in

the first place. The destruction of naevi by electrolysis was slow and to some extent unreliable. Both poles should be inserted in the naevus, not one pole at another part of the body. The lecturer closed with a reference to naevoid marks, port-wine stains, and congenital dilatation of the capillaries, which were not true tumours. For these CO₂ or electrolysis might be tried, the latter method being carried out with only the negative pole under the skin and the positive pole, a flat disc soaked in brine, applied quite near. In some cases a long tenotome or very thin knife might be inserted and the skin carefully undercut.

A number of questions were asked at the close, and Mr. Fitzwilliams, in replying, remarked on the curious fact that children with naevi were mostly healthy children; in fact, he had never seen these children very ill with anything else. With regard to the possibility of vaccinating over the naevus, he had always understood that it defeated the object of vaccination if there was much bleeding; but he had vaccinated near the naevus, and when there was a good inflammatory result, a small naevus would disappear. He did not believe that a hereditary disposition to naevus had been established, though occasionally two or more members of a family were found to be affected.

Rebielus.

THE INTERPRETATION OF SYMPTOMS.

SINCE the first edition, in 1909, of his *Symptoms and their Interpretation*, Sir JAMES MACKENZIE has steadily continued his investigations into the mechanism and significance of the manifestations of disease, and accordingly this fourth edition, though arranged on the original plan and only thirty pages longer than the first, presents the results of his further studies, especially those from the St. Andrews Institute for Clinical Research, of which he is the director. The volume appears to have been passed for press last October, but it includes as an appendix, placed after the index, the author's paper on "The theory of disturbed reflexes in the production of disease," published in our issue of January 29th last, to which further reference will be made.

Sir James Mackenzie is a stern critic of loose thought, and in following his writings, as every practitioner of medicine should, the reader is apt to be haunted with the feeling that at any moment a cap may be presented that, unlikely as it might seem, exactly fits his head. Sir James's clear insight into the weak spots in the present state of medicine makes his message a wholesome if disturbing tonic to those who rest satisfied with its progress; for he insists that, though there is much laborious research and fresh symptoms are constantly being announced, the real need is for sound basic principles and the establishment of the laws governing the production of symptoms. Further, it often happens that what is supposed to be well known and commonplace is in reality so imperfectly understood that its true significance has been entirely missed. This applies particularly to the proper recognition of the mechanism of symptoms, in connexion with which "the laws of associated phenomena" should be given due weight, for in an illness there are various manifestations due to the causal agent disturbing many reflexes, and too often the most prominent of these symptoms is erroneously labelled as the primary morbid condition—for example, "the soldier's heart," or neurasthenia, is but one aspect of a diminished resistance to stimulation brought about by infection. A clearer knowledge of the mechanism of the less obtrusive symptoms would therefore facilitate the detection of the causal agent.

The study of symptoms is so ancient and familiar that it may appear a hard saying that at present symptomatology is in the same state of confusion as chemistry was before Dalton brought out the atomic theory, and that there is an urgent need for a classification of symptoms based on some law of nature that reveals the mechanism of their production. As the result of the recent conferences and work at the St. Andrews Institute, the conclusion—already foreshadowed in the early part of the volume—has

¹ *Symptoms and their Interpretation*. By Sir James Mackenzie, M.D., LL.D., F.R.S. Fourth edition. London: Shaw and Sons, 1920. (Demy 8vo, pp. 319; 8 figures, 15s.)

been reached that the vast majority of the symptoms of disease are disturbances of normal reflexes; thus the muscular rigidity in abdominal disease is an exaggeration of the normal reflex which maintains the tone in these muscles. The two main reflexes due to cardiac failure are breathlessness due to insufficient blood supply to the respiratory system, and pain from exhaustion of the myocardium; in some conditions these may occur together, in others one only is prominent; thus in auricular fibrillation the respiratory reflex is readily produced, whereas pain is rare. In angina pectoris there are multiple reflexes—namely, sensory, in which pain and hyperalgesia affect the chest, arms, head, and neck; motor, secretory and respiratory. The pain is a viscerosensory reflex, due to a summation of stimuli; the sense of constriction is caused by spasm of the intercostal muscles, a visceromotor reflex, analogous to muscular rigidity in abdominal disease, best seen in the elderly.

This new "law" of the disturbance of normal reflexes may appear simple, but at this stage it is difficult to estimate its future influence on medicine. Sir James Mackenzie has done so much for the advance of medicine that his assurance that its application in practice and in research has already shown it to be of service must carry great weight.

MANSON'S TROPICAL DISEASES.

The establishment of the study of tropical diseases as a settled part of medical discipline may properly be held to date from the publication in 1898 of a textbook on the subject by Dr. Patrick Manson.² It was reprinted three times within a year of its first appearance; a new edition was published in 1900; and a third edition, revised by the author, who had in the interval become Sir Patrick Manson, appeared in 1903. The work has maintained its position as the best general textbook on the subject, and the familiar dumpy volume has been the companion of English-speaking doctors in all parts of the tropics. The new, seventh, edition shows many changes: a larger page is used, so that, though the new edition contains no greater number of pages than the sixth, it nevertheless contains a good deal more matter. It is edited by Dr. PHILIP H. MANSON-BAHR, who has introduced much new material; in its selection he has had the advantage of the help and advice of Sir Patrick Manson himself, so that the transition from the original author to the new editor is made in the best circumstances.

The contents of this new edition are well arranged. Section I deals with the fevers; Section II with general diseases of undetermined nature; Section III with abdominal diseases; Section IV with the infective granulomata; Section V with animal parasites and associated diseases; Section VI with diseases due to poisons, including snake-bite; Section VII with tropical skin diseases; and Section VIII with local diseases of uncertain nature. There are three appendices, dealing with medical protozoology, medical helminthology and entomology, and laboratory methods as applied to clinical medicine in the tropics. The separation of the purely technical descriptions of the protozoa, helminths, and insects from the clinical part of the subject is convenient, as it avoids fatiguing the reader when he is studying the first part of the book. After completing this, he can then go to the appendices for details. All the articles have been brought up to date and are clearly written. Special mention may be made of the account given of the new work on the etiology of yellow fever, of the new chapters on infectious jaundice, and of that on typhus. The highly interesting discussion upon the diagnosis of fevers in the tropics indicates how much the modern doctor must now know in the way of laboratory tests for the diagnosis of disease, and with what care he must approach the subject if he is to form a correct estimate of the condition he is called upon to treat. The chapter on schistosomiasis is excellent, as are also those on dysentery; modern methods, of course, permit the differentiation of the different forms of this disease with an accuracy unknown even a few years ago.

² *Manson's Tropical Diseases*. Edited by P. H. Manson-Bahr, D.S.O., M.A., M.D. (D.T.M. and H.) Cantab., M.R.C.P. Lond. Seventh edition, revised and enlarged. London and New York: Cassell and Co., Ltd. 1921. (Demy 8vo, pp. 976; 401 figures, 27 plates. 30s. net.)

The criterion of a work on tropical medicine at the present day must be judged by the extent to which it will prove of value to the student as a textbook, because the standard of the examinations for the various diplomas in tropical medicine is now very high, and calls for a thorough, accurate and up-to-date knowledge of all the scientific matters included in this branch of medicine. Having read the work with great care, we may state that it fulfils this criterion satisfactorily; it may therefore be recommended to the student working for his examination as well as to the tropical practitioner.

In a work containing so many details some errors are inevitable, but in this book they are few. Maurer's dots are not the same as basophilic granules, and it is more correct to talk of tertian fever as occurring every third day than every second. Such slips as these can easily be corrected in subsequent editions. This edition is illustrated by many excellent diagrams, drawings and coloured plates. There are ten new plates in colour and upwards of 150 new figures in black and white. The wise liberality of the publishers in this respect adds very much to the value of the book. It is an excellent work in every way, and may be confidently recommended to all interested in tropical medicine.

THE LIPOIDS IN INFECTION AND IMMUNITY.

A CRITICAL review of the present state of knowledge concerning the part played by lipoids in infection and immunity is contained in a recent monograph by Dr. G. LINOSSIER of Lyons,³ presented to the fourteenth French Congress of Medicine held at Brussels in May, 1920. As a result of his investigation of the literature, Dr. Linossier holds that it has still to be established that pure lipoids can act as antigens—that is, can give rise to specific antibodies; and also that the part they play in the defence has still to be adequately defined. This notwithstanding, it must be admitted that there is a strong probability that lipoids play a far more important part in both processes than is yet realized, and those who wish for a critical summary of the evidence at present available on this matter will do well to possess themselves of Dr. Linossier's suggestive little monograph.

ORTHOPAEDIC APPARATUS.

IN *Gli Apparecchi Ortopedici*⁴ Professor DELITALA has produced a handbook on orthopaedic instruments which should prove useful to Italian-speaking students and practitioners. Professor Putti of Bologna, who has furnished a preface, says that in Italy the study of orthopaedic surgery, despite the good work due to it in the war, is in a backward condition. There are few universities where it is taught and few hospitals where it is practised. Textbooks on the subject in the Italian tongue are wanting. (Professor Curcio's book on the same subject was published only this year.) The production of the excellent journal *La Chirurgia degli Organi di Movimento*, under Professor Putti's direction, has done much to raise the credit of Italian orthopaedics, and this is to be followed up by a series of monographs emanating from the Rizzoli Institute at Bologna, of which that now under notice is the first to appear. Professor Delitala is well known as an orthopaedic surgeon, and in this small book he has produced a useful guide in which he lays down the principles upon which all sorts of orthopaedic appliances should be made, describes the mechanism of the best known forms, and gives directions for manufacture. As might be expected, not only are steel and leather appliances described, but those of celluloid and other materials such as plaster-of-Paris, of which the technique is well set forth.

It is refreshing to find a book published on the continent of Europe in which a good deal of importance is given to the hip and knee splints of H. O. Thomas. It has been the custom of French and German writers to ignore these exceedingly valuable appliances, to the use of which so much of the successful treatment of fractures in the British and American forces in the late war was due. Perhaps the best things in the book are the articles on celluloid corsets and splints stiffened with light steels;

³ *Les Lipoides dans l'Infection et dans l'Immunité*. Par le Docteur G. Linossier. Paris: Baillière et Fils. 1920. (Pp. 108. 10 francs.)

⁴ *Gli Apparecchi Ortopedici*. By F. Delitala. Bologna: L. Capelli. 1921. (Cr. 8vo, pp. 296 + xii; 248 figures. 4L.)

a novelty is the use made of vulcanized rubber for splints for pseudarthrosis and flail-joint and other disabilities of the upper extremity. In this connexion Professor Delitala makes the interesting statement that, although caoutchouc will adhere closely to only one metal—namely, 18 carat gold—he has found that it will hold closely enough to aluminium, and that this metal, when entirely enclosed in vulcanized rubber, forms the best means of reinforcement. For the lower extremity celluloid and steel are preferred. In an appendix an interesting illustrated account is given of the workshops of the Rizzeli Institute, which cover a space of 1,500 square metres, a little distance from the main buildings.

It cannot be said that Professor Delitala's monograph is of equal value to the excellent little book of Dr. Dueroquet, *La Prothèse Fonctionnelle des Blessés de Guerre* (reviewed in our columns June 28th, 1919, p. 800), but it approaches to it, and supplies in the Italian language a want which has not yet been adequately met in the English.

"THE EXTRA PHARMACOPOEIA."

The first volume of the new edition of *The Extra Pharmacopoeia*⁵ appeared last June, and was reviewed in this JOURNAL on July 17th, p. 78. The second volume of the new edition, which is about to appear, is considerably larger than the corresponding volume of the last edition, but though it contains over 700 pages, yet it is of convenient size, and the increase in bulk is in part due to the inclusion of a complete index for both volumes. In the last edition the first volume contained the index for both parts, but the new arrangement of adding an index to each volume is a great convenience in a work of this nature, which is specially intended for rapid reference.

The first third of the volume deals with the chemistry of drugs, and contains information about tests for purity, methods of preparation, and tests for activity of drugs, together with tables of organic analysis. Analytical methods of special interest in public health are described in another part of the book, and descriptions are given of the methods of analysis of water, milk, and butter. The antiseptic power of disinfectants and the methods by which comparative figures are obtained are also described; under the heading "Nutrimenta" the bleaching and the adulteration of flour is described.

The sections of chief interest to medical men are those dealing with special methods of treatment and the descriptions of the chemical and bacteriological methods used in practice. All the latest methods of analysis of the blood, urine, faeces, and stomach contents are described, and full information is given concerning the preparation of dyes and culture media and the identification of micro-organisms.

The different portions of the volume are of special interest to different classes of medical men, but the following subjects may be specially mentioned because they are of general interest, and the recent information concerning them is given very fully: the therapeutic action of x rays, electric currents, and ultra-violet light; the physical chemistry and therapeutic action of radium, and radioactive salts; the various chemical and physiological methods for the standardization of digitalis; the tests for renal function; and the determination of the reaction of the blood.

The book also contains a variety of other information which it is difficult to classify—such information as proprietary medicines and the composition of mineral waters, a list of British health resorts, and glossaries of medical terms in eight foreign languages. Moreover, abundant references are given to clinical and also to scientific literature.

Enough has been said to show how wide is the range of subjects covered in this volume. The authors have succeeded in compressing into one volume an excellent summary of all the clinical methods in general use, including all the most recent advances, and therefore their work is of particular value to those who desire concise information concerning these methods.

The special advantage of the book is that it contains

⁵ *The Extra Pharmacopoeia*. By W. Harrison Martindale, Ph.D., Ph.C., F.C.S., and W. Wynn Westcott, M.B.Lond., D.P.H., Vol. II. Seventeenth edition. London: H. K. Lewis and Co., Ltd., 1921. (Fcap. 8vo, pp. 6-8 + 32. 17s. 6d. net; 18s. post free throughout the world.)

easily accessible information about most of the laboratory tests used in clinical practice. The chief improvement that we can suggest is that the sections might be arranged in a somewhat more logical sequence; for example, the methods of analysis of blood, urine and faeces are given together, but the analysis of gastric contents is dealt with elsewhere; again, the analysis of water is separated from that of butter and milk by a description of the contents of mineral waters and a list of health resorts. The index is, however, very full, and therefore these irregularities in arrangement are not of any great importance.

NOTES ON BOOKS.

THE address which the Hon. JOHN W. DAVIS, the late Ambassador of the United States, gave last January at University College, London, on *The Constitution of the United States*, has now been published from the University of London Press.⁶ In this discourse is traced the history, modification, and development from its British sources of the American Constitution—"the most wonderful work ever struck off at a given time by the brain and purpose of man," as Gladstone described it.

In the seventy-four short poems brought together as *Thoughts of a Nature Lover* Dr. KENNETH ROGERS shows a talent for verse that he has hitherto hidden from the world at large and a certain touch of pathos and meditative reflection on the fleeting years since he was at Temple Grove, Marlborough, and St. Bartholomew's Hospital. This is especially seen in the lines "To Savernake Forest," which he naturally regards "with a love unchanging from a vanished day," in the biographical "Retrospective," and in "Farewell to an old friend." In addition to the main theme, the joy of Nature, there are verses on various aspects of human nature, on the events of the war, and translations from the French and Italian. In "The captured German guns in the Mall" there is a pretty conception of these "spectres from an evil dream" which

"... children now, with laughing Joys,
Delight in them as wondrous Toys."

⁶ *The Constitution of the United States*. By the Hon. John W. Davis. 1921. London: Hodder and Stoughton. (Demy 8vo, pp. 36. 1s. 6d. net.)

⁷ *Thoughts of a Nature Lover*. By Kenneth Rogers, O.B.E., M.D. London: Holden and Hardingham, Ltd. 1921. (Cr. 8vo, pp. 125. 5s. net.)

THE VOLUNTARY PRINCIPLE IN LONDON.

INTERIM REPORT OF THE KING'S FUND POLICY COMMITTEE.

IN an article in the JOURNAL of February 5th last we gave a full account of the report by the Executive Committee of King Edward's Hospital Fund for London upon the policy to be recommended for the preservation of the voluntary system of hospital management and control. In accordance with that report the President and General Council of the King's Fund, on January 26th, passed a series of resolutions and appointed a special Policy Committee with the instruction to work out details of the policy and to take steps to recommend it to the Government, to Lord Cave's Committee of Inquiry, to the hospitals, and to the public. The Committee consists of Lord Stuart of Wortley (Chairman), Sir Cooper Perry, Viscount Burnham, Lord Somerleyton, Sir Frederick Fry, and Sir Alan Anderson.

At the last meeting of the President and General Council, held on April 12th, the Policy Committee presented an interim report, dated April 4th, which has now been issued. This states that written and oral evidence was submitted to Lord Cave's Committee in amplification and support of the statements contained in the Executive Committee's report and the resolutions of Council,¹ together with a further analysis of the figures supplied to the Fund by the hospitals in January.

Financial Position at the end of 1920.

While the income of the London hospitals had steadily risen since 1913, due mainly to the growth of voluntary contributions, the expenditure increased at a far greater pace. Thus the aggregate income from normal sources in 1920 was £2,447,000, while the expenditure was £2,841,000, leaving a deficit of £394,000, or about 14 per cent., on the

¹ Copies of the Policy Committee's Interim Report and of the thirteen resolutions passed by the General Council can be obtained from King Edward's Hospital Fund for London, 7, Walbrook, E.C.

working of the year. Emergency grants from the King's Fund and the National Relief Fund almost exactly wiped out that deficit, but these sources of income are non-recurrent. Accumulated bank loans amounted to £544,000 on December 31st, 1920. The individual differences between income and expenditure varied widely, of course, and from its study of these the Committee infers that the problem, though serious enough at the hospitals which have large deficits, ought not to prove insoluble.

Alternative Remedies.

Accepting the decision of the Council that voluntary contributions would need to be supplemented, at all events temporarily, by some other sources of revenue, the Committee has considered the various alternatives put forward. No final conclusions have been reached, but a solution is at present being sought along the following lines:

"The supplementary income must be adequate to meet the present deficits at hospitals that have deficits, without piling up surpluses at some hospitals and leaving others in difficulties; it must be capable of expanding to meet the cost of necessary extensions and developments; and it must not endanger voluntary management or the interests of the sick poor."

The choice could be narrowed down to two alternatives: (a) Payment in some form or other for specific work (which might include payment by means of voluntary or compulsory insurance); or (b) assistance from public funds proportioned in some way to voluntary contributions.

On the subject of payment by a method of voluntary insurance the Committee makes the following reference to the Sussex scheme, of which an account was given in our issue of January 22nd, 1921, p. 129:

"It is obvious that many patients who cannot pay during illness could, nevertheless, afford to make provision for hospital treatment by some form of voluntary insurance. A comprehensive scheme, associated with the name of Dr. Dill, has begun to be put into operation in Sussex; and a Committee of the British Medical Association has recommended its adoption, with modifications, by the hospitals of London. We are not at present prepared to endorse this scheme, especially as it has not yet been considered by the Hospital Saturday Fund."

After discussing the first alternative (a) in some detail, the Committee considers that both forms of insurance—voluntary and compulsory—should be thoroughly explored, in order to see whether the problem could be solved if the voluntary subscriptions of the charitable public were supplemented by a graduated system of patients' payments from those able to pay at the time of illness, and by insurance on the part of those who are unable to do so; the hospitals agreeing to limit free treatment, except in emergencies, to those unable either to pay or to insure.

The Committee has not as yet given consideration to the second alternative (b) of State or municipal assistance to encourage voluntary contributions. It thinks, however, that the principle of aid proportioned to voluntary contributions might have the advantage that it could be put into operation rapidly. Hence the possibilities of this alternative, either as a temporary expedient or as a permanent way of encouraging the maintenance of the voluntary system, should be investigated.

Emergency Assistance.

In view of the likelihood of a repetition of last year's crisis in hospital finance, the Committee notes that but for the emergency distribution of a quarter of a million by the King's Fund, some important London hospitals might have been obliged to close down or come on public funds. Should emergency aid again become necessary, it strongly deprecates any further depletion of the reserves of the King's Fund, except possibly by an advance with repayment guaranteed. Some other method, it is considered, would have to be found. One way would be by Government aid in some form wholly outside the sphere of permanent remedies; for instance, a payment towards the loss borne by the voluntary system in the treatment of service patients during the war. Another way would be by Government aid as an instalment of, or as an advance in anticipation of, some permanent remedy adopted by the time the crisis arose, but not yet worked out in detail or not yet put into full operation. Or, again, the recommendation already made by Lord Cave's Committee regarding surpluses now in the hands of the approved societies under the National Insurance Acts might possibly yield enough money in time to avoid any immediate collapse.

THE USE OF ALCOHOL IN MEDICINE.

At the annual meeting of the Society for the Study of Inebriety on April 12th, Sir ALFRED PEARCE GOULD presiding, a discussion took place on the use of alcohol in medicine.

Dr. H. H. DALE, F.R.S., in an opening address, said that it was difficult in any discussion concerning alcohol to preserve a perfectly objective and scientific attitude, but he thought they could agree that their views on the social significance of alcohol had no bearing on its status as a remedy. It ought to be possible to hold the opinion that alcohol in daily life was harmful and at the same time feel no obligation to discredit alcohol as a drug when properly prescribed. A great deal of unnecessary heat had been wasted over the question whether or not alcohol was a food. The question was primarily one of nomenclature. If by food was meant a substance which by its combustion in the body could liberate energy, the claim of alcohol to rank as a food in that sense was beyond dispute. But that did not in the least imply that alcohol was a proper or desirable food for a healthy man; that must be determined on other grounds, and he doubted whether anyone would now be found to advocate the replacement of so much carbohydrate or fat in the normal diet by alcohol. But in the case of the sick the conditions were different. It became in that case relevant to remember that alcohol differed from all the other constituents of diet, save glucose, in that it was ready for absorption and use without preliminary digestion. In severe febrile and acutely toxic conditions in which the secretion of the digestive ferments was more or less in abeyance, it did seem that alcohol might have some advantages as an emergency food; and the effect of alcohol on the brain and central nervous system, which forbade its use as a proper substitute for other foods in health, did not in his opinion contraindicate its use in the case of the sick. Its action in weakening the critical judgement and blunting the fine edge of sensibility, however much this might lead to the lowering of efficiency in the ordinary business of life, might be and in many cases was all to the good when dealing with a restless, anxious, and fever-stricken patient. The sedative effect of alcohol might be as important as its food value in such cases. In one other direction alcohol might be regarded as an abnormal food—namely, in the preliminary period of starvation in the modern treatment of diabetes, when it was very necessary not to give the patient anything which he could possibly convert into sugar. The one source of energy which could be given without vitiating the treatment was alcohol. Dr. Mellanby had told him of one business man who had had to give up his work on account of diabetes because a diet low enough to keep his urine free from sugar was insufficient for the energy needs of an active life; but that patient was able to resume his work and again lead a normal existence as the result of adding to his diet a measured, properly prescribed ration of alcohol, which, alone of all possible foodstuffs, supplied the missing units of energy without leading to renewed excretion of sugar. But such cases had nothing whatever to do with the old port wine tradition. The prescription of alcohol for convalescent or weakly patients who were able to take ordinary foods was a very much more doubtful and difficult subject. From the experimental point of view he found it hard to believe that alcohol had any special value in such conditions, except in so far as by making the patient more comfortable, and rendering him less sensitive to the tedium of convalescence, it might indirectly improve his appetite, and thereby improve his digestion and assimilation. He had been told that the cases in which the giving of alcohol during convalescence had led to the alcohol habit were few or unknown, but that was only a small aspect of the subject; it was a much more serious danger that the casual recommendation of stout or port wine in such circumstances, on the basis of a not yet extinct faith in its efficacy for building up the system, might reinforce with the weight of medical opinion the natural desire of the laity to believe that what they liked was good for them.

As for the supposed value of alcohol as a stimulant, the verdict of experimental pharmacology had for some years been clear. He believed that the basis for the idea that alcohol was a cardiac and respiratory stimulant was the reflex effects of its action on the buccal and oesophageal

mucous membrane, an action which it shared with ammonia, for instance, in smelling salts. This action accounted for the great preference which people had for brandy over other forms of alcohol, and old brandy in particular. He believed, however, that there was room for a systematic investigation into the action of alcohol in abnormal conditions in which the heart was weak and the blood pressure low, in order to settle the question whether there was anything, after all, in the claim that alcohol had a stimulant action on the circulation. The experiments which seemed to negative a stimulant action on the heart and respiration had been carried out on normal animals and man, and the possibility remained that it might have some stimulant action on functions abnormally depressed, which those experiments had missed altogether. If such an effect existed, there was at present no evidence to warrant them in assuming its existence. As for the value of alcohol in promoting digestion, while there was experimental evidence that alcohol would cause a rather profuse outbreak of gastric juice, the juice in question was not the normal juice, but a fluid low in acidity, and very poor in gastric ferment. Any effect which alcohol might have in promoting digestion must be due to its action in relieving anxiety or the effects of pain or fatigue.

Dr. Dale concluded by deprecating two attitudes towards the therapeutic use of alcohol: one, that alcohol was a mysterious fortifying substance which would build up the constitution, and could be prescribed without danger and with probable advantage; the other, that because it was a dangerous thing for the public to use, its rational use in medicine was to be avoided.

Dr. O. LEYTON described some experiences with alcohol in the early stages of the starvation treatment of diabetes. It appeared that, after some period of semi-starvation, patients managed to adapt themselves to the limited diet, even though alcohol was not continued; either the body acclimatized itself to the small supply of food, or else the patients learned to utilize cellulose. He had not sufficient evidence to show that it was necessary for alcohol to be continued indefinitely in this treatment of diabetes. He believed with Dr. Dale that the only way in which alcohol could improve digestion was by altering the state of mind, not by any direct action on the stomach.

Sir ROBERT ARMSTRONG-JONES said that he had found alcohol to have a definite hypnotic effect in some cases of acute mania, and in that condition it was eliminated from the skin better and more quickly than in melancholia. In juvenile melancholia and senile depression the prescription of alcohol was inadmissible. He had had 330 cases of general paralysis of the insane under his care while resident at Claybury, and he had seen a number of private cases, and he had to record no good effect from the administration of alcohol. In cases of acute delirious mania, puerperal insanity with rapid exhaustion, the free administration of alcohol was often the only thing that would save life. He had tried various stimulating diets, but dry wine in the shape of dry sherry or moselle had saved lives when nothing else had availed.

Professor RANSON said that experimental evidence proved that when the respiratory centre was depressed the effect of alcohol was to depress it still further. Alcohol was not a stimulant to respiratory action, unless reflexly from the mouth.

Mr. ARTHUR EVANS said that during the last two years at the London Temperance Hospital he had done 254 operations, with 12 deaths. The deaths were practically inevitable from the nature of the cases. Alcohol was given in no instance. He claimed that the statistics of 44,000 patients admitted since the foundation of the hospital—to only 135 of whom, mostly cases of pneumonia, was alcohol given—compared well with those of other institutions.

Sir A. PEARCE GUILD, from the chair, in closing the discussion, remarked that the withholding of alcohol in the cancer wards of the Middlesex Hospital and the administration of morphine with a much more sparing than formerly had added greatly to the patients' comfort.

A NEW medical faculty has recently been established at Recife, in the government of Pernambuco, so that there are now seven medical faculties in Brazil. As the country possesses 35,000,000 inhabitants, this number of medical schools is considered to be hardly sufficient.

THERAPEUTICS OF RADIUM.

ANNUAL REPORT OF THE LONDON RADIUM INSTITUTE.

THE annual report of the London Radium Institute for 1920 is constructed on a different plan from its predecessors. The details of cases are confined to a table, and Mr. Hayward Pinch, F.R.C.S., who has been its medical superintendent since the Institute was founded ten years ago, devotes the body of the report, which fills nearly thirty pages, to a discussion of general questions which will be of direct value to others who are doing clinical work with radium or desire to form their own opinion of its value.

After a short account of the physics of radium rays he discusses their action on normal tissues, and from a brief review of the pathology of the diseases treated passes to a consideration of the reasons which should determine the selection of the class of irradiation to be employed and the length of exposure to be given to produce a destructive or stimulant effect, as may be necessary. A statement as to the absorption of beta and gamma rays prepares the way for particulars of the screening to be used to obtain rays of different qualities. The screens used for therapeutic purposes are of a thickness which does not absorb more than a small percentage of the gamma rays, but stops a percentage of the beta rays ranging from practically all to only 3.7 per cent.

In practice the use of radium is governed by the knowledge that has been acquired as to the action of the several sorts of rays on the elements of healthy tissues and of diseased structures. The alpha rays are particulate, travel relatively slowly, and are so little penetrating as to possess no therapeutic value. The beta rays, negative electrons travelling with a velocity of the order of that of light, are of the type of β rays and, like them, present a considerable range of penetration, so as to be divisible into "soft" beta rays, stopped by 0.2 mm. of aluminium; "medium," which pass through this thickness of aluminium but are stopped by 0.2 mm. of silver; and "hard," which pass through this thickness of silver. The gamma rays, of the same type as the most penetrating or hardest β rays, are only slightly diminished by the most absorptive screens used for therapeutic purposes; they easily penetrate the skin and reach the internal organ. The beta rays do not penetrate far, the hard being reduced to about 6 per cent. by 1 cm. of body tissue. Beta rays unshielded are used in the treatment of epitheliomata which tend to fungate and not to invade the tissues; for those that so tend the soft rays are cut out and medium and hard rays only used.

As a general principle it may be assumed that radium rays stimulate growing cells, the effect being the greater the more rapidly the cell is growing, until stimulus is replaced by destruction: in lympho-sarcoma the destruction may be so rapid that the patient suffers from well-marked symptoms of toxæmia with rise of temperature to 101° to 102°. On the other hand, cells of fibrous tissue may be just sufficiently stimulated to form bands or tracts of such tissue, and in this way continuance or spread of the malignant cellular growth may be hindered. Growths of mesoblastic origin are more susceptible than those of hypoblastic or epiblastic origin: between the two last named certain differences are to be observed, the former being more readily influenced by short exposures to large quantities of radium salts, the latter by long exposures to small amounts.

The Skin.

The effects produced in some normal tissues and organs by exposure to beta and gamma rays are reviewed. In the skin the first effects are proliferation and then enfoliation of the epidermis, congestion of the dermis with degeneration of hair follicles and sebaceous glands, multiplication of the connective tissue cells, forming a plexus which almost obliterates the normal fibrous and elastic tissue, and proliferation of the lining cells of the blood vessels (embryonic regression). Eventually the fibroblasts become arranged in parallel layers containing a relatively large number of elastic fibres, so that the scar is soft and supple. Regeneration of the hair follicles and sebaceous glands takes place also. The proliferation of the cells of the blood vessels is followed, if the radiation be prolonged and intense, by degeneration and leucocytic infiltration. Milder radiation for short periods at long intervals, leads to fibrosis of the walls: it is in this way that the cure of angiomas is induced.

The Blood.

Periodical examinations have been made of the blood of nurses and laboratory workers at the Radium Institute, who are subject to frequent short exposures to the gamma radiation. Dr. J. C. Mottram, Director of the Research Department, has observed at first a slight diminution in the number of red cells, accompanied by a rise in the colour index. If exposure to radium continues, the increase is succeeded by a decrease both in the number of red cells and in the haemoglobin until both have fallen to 50 per cent. or lower. The more important effect is on the white cells. Leucopenia invariably occurs; the white cells, Mr. Pinch states, are frequently reduced to half the normal proportion, the reduction falling chiefly on the polynuclear leucocytes and the lymphocytes. The effect is slowly produced, but is very persistent, and it may be many months after complete withdrawal from radium work before the percentage again becomes normal. In a paper published last December,¹ Dr. Mottram described three deaths among radium workers, two in England and one in France; in all three aplastic pernicious anaemia was present and in two death was ascribed to this condition; in the third there were signs also of infective endocarditis.

The association of mild anaemia of the pernicious type as above mentioned with these three cases of profound aplastic pernicious anaemia led to the conclusion that the important etiological factor was exposure to radium and indicates a direct action of the gamma rays on the bone marrow. This suggestion was tested by exposing rats to varying amounts of gamma radiation; when their bone marrow was compared with that of normal animals the number of mitoses in the radiated animals was found to be smaller, indicating a decreased output of blood cells. During 1920 the workers at the Institute were better protected, and by February, 1921, the blood condition had reverted to the normal.

Radium rays quickly produce a profound effect on the spleen; the connective tissue increases, the cellular elements diminish, and there is an almost complete disappearance of lymphocytes; concurrently the proportion of polynuclear and large mononuclear cells in the blood is greatly decreased, and there is an accumulation of red corpuscles in the bone marrow and many small haemorrhages into its substance.

Dosage.

Mr. Pinch devotes rather more than half of the space his report occupies to consideration of the mode of applying radium in the treatment of various forms of disease in which the method has proved of value. The question of dosage is, of course, of very great importance; for, if the dose be too weak, the pathological cells, instead of being checked or destroyed, may be stimulated to increased activity, whereas if the dose be excessive, destruction not only of the morbid, but also of the normal cells occurs, resulting in great loss of tissue and the formation of an intractable ulcer or fistula. For full details the report itself must be consulted; we can only summarize the recommendations and indicate their general nature.

Reference has already been made to the treatment of epitheliomata, but it may be added that tubular epitheliomata characterized by long, finger-like columns of cells running at right angles to the skin surfaces and permeating the subcutaneous tissues should, it is advised, be treated almost entirely by gamma radiation, since 94 per cent. of the beta radiation is absorbed by one centimetre of tissue, and these growths often extend much more deeply. Cross-fire radiation—the apparatus being so applied that the focus of their combined radiation corresponds with the centre of the growth—should be adopted. The exposure should be prolonged in a series for twenty-four to thirty hours, and the series repeated at intervals of not less than four weeks. A screen of two millimetres of lead, which cuts off practically all the beta rays, should be used.

Spheroidal-celled carcinomata, the most common and typical form being cancer of the breast, may be beneficially affected, especially in spare women who have passed the menopause. In such a patient, possessing a fair inherent power of resistance, the growth in its earliest stage shows on microscopic section all transitions from a dense central scirrhous focus to a comparatively medullary condition at the periphery. In the former there are but few cells and

much connective tissue; in the latter connective tissue fibres are scanty and malignant cells predominate. The object of treatment by radium is to reinforce Nature's attempt at the arrest of the disease. Prolonged gamma radiation diminishes the vitality and arrests the proliferation of the malignant cells, but stimulates the multiplication of the fibroblasts. It is not sufficient to radiate the primary growth, equal attention must be paid to the surrounding lymphatic areas.

Columnar-celled carcinomata, the most common site for which is the intestinal canal, are difficult to treat with radium, both on mechanical grounds and because they originate in a mucous membrane with a submucosa abundantly provided with lymphatics, so that infiltration speedily occurs. Gamma radiations from screened applicators have been used for carcinoma of the stomach, small intestines, and colon, but little real benefit has been observed. In the rectum, however, direct application is possible; if the tumour be small and exuberant a screened emanation tube may be inserted into its substance. If the growth be annular, the introduction within the lumen of a powerful tube of 150 or 200 mg., screened with 2 mm. of lead, for eighteen hours may diminish the rate of growth and lead to healing of the ulceration, lessen the existing circumjacent infiltration, and render the condition operable.

Sarcomata are best treated by gamma irradiation; large quantities of radium should be used and the applicators disposed so as to secure equal intensity of radiation in all parts of the growth; often this is best accomplished by burying one or more radium tubes, screened with 1 mm. of silver, in the centre of the mass. Powerful applicators, screened with 2 mm. of lead, should be applied over and around its circumference. The reaction that may be produced owing to the rapid destruction of the sarcomatous cells has already been mentioned.

In *melanoma* (melanotic sarcoma), which is believed to arise from the pigment cells of the corium, and to be, therefore, of epiblastic rather than mesoblastic origin, beta rays may be used to produce an intensely destructive reaction. In such cases the lymph channels leading from the primary focus should at the same time receive prolonged gamma radiation, in order to destroy any foci that may be present.

Rodent ulcer is, for clinical purposes, recognized to occur in two forms: in the first, of a hypertrophic and exuberant type, with slight superficial ulceration and a distinct rolled edge, the prognosis is good. Unscreened apparatus emitting beta rays is used for one to three hours, according to the density of the lesion. The rolled edge is evidence of a considerable degree of resistance to the disease, and the irradiation recommended produces degenerative necrosis of all the malignant tissue and possibly of a small layer of the normal tissue. The stimulant action of the gamma rays induces rapid multiplication of the fibroblasts, and the resulting scar, though slowly produced, is smooth, soft, and supple. Growths of the excavating type, with thin overhanging edges and a soft gelatinous base, form the second class. The absence of a rolled edge shows that the defensive powers are deficient and the prognosis is not so good. A smaller dose must be used, and it must extend beyond the visible margin in order to deal with outlying invasive columns of cells. Recurrence is, however, very frequent. In long-standing cases, with great destruction of the tissue and invasion of the mucous, cartilaginous or bony tissues, the beta rays should be cut off. Radium irradiation of any kind is powerless to cure rodent ulcer of bony tissues, and has little influence on that of cartilage. Affected portions of these tissues should, therefore, be removed before radium treatment is begun. Gamma irradiation applied to the borders of the growth and its deeper processes will often arrest the progress of the disease, diminish the pain, and induce some slight degree of repair.

Endotheliomata, met with most commonly in connexion with the parotid gland, but sometimes observed in the submaxillary gland and ear-tid body, can often be usefully treated by gamma rays. If the growth be inoperable it should be treated by cross-fire, using heavily screened external applicators emitting gamma rays only, supplemented by the insertion of a radium tube screened with 1 mm. of silver into the centre of the growth for twenty to thirty hours.

In *uterine fibro-myomata* radiation may be used when

¹ Archives of Radiology and Electrotherapeutics.

the patient objects to surgical operation. When hæmorrhage is the principal symptom relief may confidently be anticipated from the introduction of a 100 mg. tube, screened with 2 mm. of lead and rubber, into the uterine cavity, supported by a plate of equal strength, screened in a similar fashion and applied externally over the fundus. Exposure of twenty-four hours should be given, to be repeated, if necessary, after three months. The treatment causes exfoliation of the hypertrophied and congested uterine mucous membrane, which is afterwards replaced by healthy cells, together with proliferation of the endothelial cells of the enlarged uterine blood vessels and perivascular fibrosis, leading eventually to endarteritis obliterans. Treatment cannot be counted upon to diminish the size of the tumour unless it be of the soft myomatous vascular type. In a patient nearing the climacteric it may be proper, with her consent, to attempt to produce premature menopause by supplementing irradiation of the uterine cavity by prolonged irradiation of both ovaries with powerful screened applicators.

Spleno-medullary leucocytæmia in the early stage may be greatly benefited by gamma rays, using flat applicators containing from 200 to 500 mg. screened with 2 mm. of lead, for twenty to thirty hours. This is usually followed by a reduction of 50 per cent. or more in the white blood cells and a decrease in the size of the spleen. If extensive fibrosis of the interstitial tissue of the spleen has already taken place, as may happen after much treatment with x-rays, no great decrease in the size of the organ can be expected, but the number of white blood cells may be considerably reduced. The treatment may have to be repeated in two or three months.

Lymphatic leucocytæmia is often benefited by irradiation with gamma rays for periods of from twenty to thirty hours. A decrease in the number and percentage proportion of the leucocytes occurs, and may persist for two months or more, but the ultimate prognosis is bad.

Brophthalmic goitre may be materially benefited by exposures to about 200 mg. of radium, screened with 2 mm. of lead, for a total period of twenty-four to thirty hours; temporary exacerbation follows, but is succeeded by improvement associated with fibrosis of the connective tissue of the thyroid.

Tubercle bacilli in cultures are not killed by an exposure of less than at least 100 hours to radium rays, but shorter radiation is believed to diminish their vitality, and it is thought that the beneficial effect observed in lupus is brought about in this way. If ulceration has not occurred, applicators screened with one-tenth of a millimetre of lead, which cuts off three-fourths of the beta rays, may be used for two or three hours, and repeated at intervals of about six weeks; no breach in the skin is produced, the congestion and induration are much lessened, and after repeated exposures the skin becomes apparently normal. If the patch of lupus is ulcerated but superficial, with little accompanying induration, an unscreened exposure of an hour or an hour and a half, utilizing practically all the beta rays, produces a destructive reaction of moderate degree, which is followed by the formation of a smooth and supple scar. In lupus of long standing with extensive ulceration and destruction, screening with 2 mm. of lead, yielding the gamma rays only, for a total exposure of twenty to thirty hours is preferable. In tuberculous adenitis cross-fire irradiation may be of use if caseation has not taken place.

In *capillary naevi*, whether "spider" naevi or port wine stain, screening with 0.1 mm. of lead, which allows the hard beta rays as well as the gamma rays to pass, should be used to produce proliferation of the endothelial lining of the vessels; their slow constriction follows the gradual development of fibrous tissue from newly formed fibroblasts. The treatment of cavernous naevi by radium is commonly very successful, and should be undertaken as early as possible, even in infancy.

CHEMICO-PHYSICAL LABORATORY.

Mr. W. L. S. Alton, F.I.C., Director of the Chémico-Physical Laboratory of the Institute, gives an account of the method in use for separating radium emanation in a condensed form for therapeutic purposes.

Dr. Mottram reports that the Medical Research Council has lent 220 mg. of radium to the Research Department.

ROYAL MEDICAL BENEVOLENT FUND.

ANNUAL MEETING.

THE annual meeting of the Royal Medical Benevolent Fund was held on April 5th, when Sir Thomas Barlow, Bt., President, was in the chair.

The annual report showed an increase of £530 in donations and subscriptions over the previous year, while the amount distributed in grants and gifts was £4,021, as against £3,897 in 1920. Attention is called to the fact that the annual grants which the committee can allocate depend upon the amount of donations and subscriptions received, and all friends of the Fund are urged to make its wants more widely known, preferably by personal canvass. Owing to the diminished purchasing power of money, it is essential that the average grants should be considerably increased. The annuitants numbered 178.

The War Emergency Fund had made grants amounting to £5,926, and had thus rendered invaluable assistance to a large number of medical practitioners who on demobilization had found themselves on return to practice unable to carry on without such help. The committee had already agreed to bear the cost of the education of twenty-five boys and girls at public schools, and they would welcome applications for such purpose on behalf of any who are eligible for help from the fund. The total sum received for the fund was £34,818, and the amount expended was £18,920.

The committee express their thanks to the editors of the BRITISH MEDICAL JOURNAL and the *Lancet* for their great assistance in publishing reports, and to the Medical Insurance Agency for its gift of £375 towards the general expenses.

The following officers were re-elected: *President*, Sir Thomas Barlow, Bt.; *Treasurer*, Sir Charters Symonds; *Honorary Secretary*, Dr. Newton Pitt.

COMMITTEE MEETING.

At the meeting of the Committee held on April 12th twenty-nine cases were considered, and £397 voted to twenty-six applicants. The following is a summary of some of the cases relieved:

Widow, aged 67, of M.D. Dub. who died in 1918. Applicant was left entirely without means. She has five grown-up children, but none of them are able to help her. Since the death of her husband she has paid rent—15s. a week—by selling her furniture. Two sisters, now dead, used to clothe and help to support her. Voted £12 in twelve instalments.

Widow, aged 61, of M.R.C.S. Eng. who died in 1915. Applicant asks help from the Fund owing to the recent death of her eldest daughter, who was her chief support. Her only income is derived from letting rooms. Son only receives 9s. a week as an engineer's apprentice, and has still another eighteen months to serve. Voted £10.

Widow, aged 87, of L.F.P.S. Glas. who died February, 1921. Applicant's husband was granted £30 in six instalments from the Fund. Applicant is now left with only the old age pension, and her rent is 7s. a week. Voted £26 in twelve instalments.

Daughter, aged 54, of M.R.C.S. Eng. who died in 1873. Owing to ill health and an operation in November last she is now incapacitated and is dependent upon her sister who cares for her living as a dressmaker. Applicant is entirely without means. Voted £18 in two instalments.

Daughter, aged 59, of M.R.C.S. Eng. who died in 1892. Applicant worked for nineteen years as a church worker in Wales, but owing to partial blindness and ill health has had to give it up. The Royal United Beneficent Association allows her £25 per annum. She also receives a little help from the Guild and a grant from the Fund for the last ten years. Relieved ten times, £135. Voted £18 in twelve instalments.

Subscriptions may be sent to the Honorary Treasurer, Sir Charters J. Symonds, K.B.E., C.B., F.R.C.S., at 11, Chandos Street, Cavendish Square, London, W.1.

The Royal Medical Benevolent Fund Guild is overwhelmed, in these days of exorbitant prices for clothing and household necessaries, with applications for coats and skirts for ladies and girls holding secretarial posts, and suits for working boys. The Guild appeals for second-hand clothes and household articles for the benefit of the widows and children who in happier times would not have needed assistance. The gifts should be sent to the Secretary of the Guild, 43, Bolsover Street, W.1.

A CERTAIN amount of confusion exists with regard to the date of the first use of ether for producing surgical anaesthesia. Dr. W. W. Keen was made recently to say that it was first employed for this purpose on September 30th, 1846. The story was correctly reported in the BRITISH MEDICAL JOURNAL of October 17th, 1895. On the date mentioned Dr. T. G. Morton, a dentist, used it with complete success for the extraction of a tooth. Ether was first used for a surgical operation on October 16th, 1846, when Morton gave ether for Dr. John C. Warren in the Massachusetts General Hospital; the operation was for a congenital vascular tumour of the neck.

British Medical Journal.

SATURDAY, APRIL 23RD, 1921.

AURICULAR FIBRILLATION AND FLUTTER.

In the Oliver-Sharpey lectures, of which the report is completed in this issue, Dr. Thomas Lewis has described an attempt to ascertain the nature of certain grave disturbances of the human heart beat. The attempt has succeeded, and the solution is presented in the lucid manner characteristic of the lecturer. After years of patient investigation, aided by able and painstaking assistants, he is now confident that he has at last solved the riddle of the disorderly action of auricular fibrillation and the rapid and varying ventricular rate in auricular flutter. That this is of very great practical importance is obvious in view of the fact that auricular fibrillation is the most common cause and frequently the immediate cause of cardiac failure.

Fibrillation of the auricle was first recognized as a clinical entity by Sir James Mackenzie in 1890. It was he who appreciated the specific nature of its disorderly action and how it differed from the other arrhythmias, but he was not then in a position to state the essential nature of the happenings in the auricles. At first he was inclined to the view that the auricles were simply distended and paralysed. Later he held that the auricles and ventricles contracted simultaneously in response to an irregular stimulation originating in the auriculo-ventricular node; the term nodal rhythm was employed to indicate this form of arrhythmia. This view in turn had to be abandoned when, in 1910, it was demonstrated by means of the electrocardiograph that the state of the auricles in these patients was identical with a condition produced experimentally even so far back as 1887, and termed auricular fibrillation. In Dr. Lewis's two lectures we have the final explanation of this important cardiac disorder.

Normally, the contraction of the auricles is a coordinated movement, occurring regularly. The stimulus originates in the sino-auricular node or pacemaker, and initiates a response in the auricles. Dr. Lewis shows that the action of the auricles is fundamentally different when flutter and when fibrillation occurs. The normal pacemaker is side-tracked, and a peculiar "circus movement" begins. In this movement the wave of contraction travels in a circular path, and constantly passes over the same ground. In order to form a clear conception of this mode of auricular activity it is essential to remember that, following every contraction of the auricular wall, the myocardium becomes refractory. This refractory stage persists for a varying time, and when it finally passes off the fibres are sensitive and responsive. When circus movement is present a wave of contraction is continuously circulating. The crest of this wave is always chasing its own wake across a gap of responsive tissue, and so long as there is this area of responsive muscle fibre in front of the advancing wave it continues to progress. It is obvious that this gap, both in its extent and also in the degree to which it has recovered its responsiveness, is of extreme importance. As Dr. Lewis indicates, if that gap could be closed, the circulating wave would come to an

abrupt termination and permit the normal pacemaker to resume control of the heart.

Auricular flutter and fibrillation are both shown to be due to the same type of abnormal contraction of the auricles—namely, circus movement. There are, however, certain important differences in the action of the auricles in these two conditions. In fibrillation the rate is about 50 per cent. higher than in flutter, and the action is not regular.

The explanation of these differences is the most fascinating section of the lectures. It is shown that the higher rate in fibrillation is due to the fact that the path of the circulating wave is shorter than in flutter. In many cases of flutter the "mother wave" encircles both venae cavae, while in fibrillation the ring of muscle fibres around the opening of the superior vena cava alone may be involved.

The reason for the irregular action in fibrillation is to be found in the condition of the responsive gap already mentioned. With the very rapid rates of contraction in flutter and fibrillation there is a decrease in the duration and quality of the responsive phase, and a condition of partial refractoriness develops; this interferes with the progress of the advancing wave of contraction. In fibrillation this barrier becomes pronounced, and the rate of the onward movement of the wave varies, producing the disorderly rhythm of the ventricles so characteristic of fibrillation of the auricle.

Prolongation of the refractory state produces a corresponding reduction of the gap. This indicates the lines along which further investigations must take place, and we may look forward to the time when we shall be in possession of remedies which, by increasing the refractory period and closing the gap, will break the vicious circle underlying both flutter and fibrillation. The foundations for such further investigations have been well and truly laid.

THE PREPARATION OF SCIENTIFIC PAPERS.

ONE of the crosses the medical journalist has to bear is the curious disregard of the literary amenities displayed by a large number of the members of the medical profession who send communications for publication. Perhaps the majority have now become aware that when writing for the printer only one side of the paper should be used: but many have not advanced to this stage. It is common for a surgeon to send in a bundle of sheets of paper of various sizes, fixed together with a safety-pin and containing, mixed up with the text, rough diagrams and bedside charts perhaps sprinkled with notes and defaced by blots and corrections. Such slovenliness is, of course, inexcusable. But writers who are prepared to take more trouble may still be guilty of the most unscientific lack of attention to details. To have a manuscript typewritten, and then to send it for publication without revision is a crime comparable to operating with unwashed hands: yet the Medical Research Council finds it necessary to insert a warning on this head among the "Notes upon the preparation of monographs and reports for publication" which it has recently issued. A comparable fault is failure to write proper names and technical terms legibly. It was said of Lord Brougham that he had three distinct handwritings—one that the majority of people could read, one that his clerk could read for a fee, and a third that had to be sent to the printer—and, undoubtedly, an experienced compositor acquires an extraordinary skill in deciphering careless writing. But he ought not to be put to the test: if the author's manuscript has been

typewritten and is uncorrected, or the correction is illegible, the skill and experience of the compositor is of no avail.

The next point made by the Medical Research Council is that footnotes as a general rule are not desirable; with this we agree; a footnote generally means that the author has not sufficiently digested his matter. It used to be a fashion with historians to print copious notes, and remonstrance was met by reference to the practice of Gibbon; but his notes, when more than references to his authorities, usually contained matter which he judged it becoming to veil in the decent obscurity of a dead language.

Another point is one to which we have several times called attention. "The decimal point," the Council says, "should never be placed at the beginning of a number, as when so placed it may well be overlooked by the compositor; for example, the form 0.5 should be used, not .5." Then, again, much trouble would be saved if authors would remember that "tables should be prepared on separate sheets and numbered consecutively in the order in which they are to be used in the text." Instructions to the printer as to where the tables may best be inserted should be given at the proper place in the text. Such instructions cannot always be carried out in the case either of tables or diagrams, owing to the size and shape of the page; therefore, when referring in the text to tables, the number of the table should be quoted, and such phrases as "the following table" avoided. Next, with regard to illustrations, diagrams, or charts, the Medical Research Council points out that they should never be drawn on the manuscript or typescript, for they have to be sent to the engravers. "Underlines," legends or descriptions, however, are sent to the printer, so that each drawing or diagram should be numbered. A drawing should be made in Indian ink on stout paper (Bristol board); in order to save time and diminish correspondence an underline bearing the same number should be attached to it or written on the back, and complete lists of all drawings, arranged in numerical order, with copies of the underlines should be appended to the manuscript or typescript. The Medical Research Council, while stating that it will, "of course, exercise its discretion as to the number and cost of illustrations," lays it down that their number should be reduced to the minimum necessary for the elucidation of the text, and that line drawings should be employed in preference to wash drawings or photographs, as the cost of line blocks is about half that of half-tone blocks, which, moreover, must usually be printed separately on special paper, multiplying the total cost by five or six. Coloured illustrations should be avoided, their cost is prohibitive in these times; yet we have known authors send in a chart in three colours, a chart which, in the case of the BRITISH MEDICAL JOURNAL, would probably have cost at least £100 to print, whereas the same effect and contrast could be obtained in black and white. Photographs are, as a rule, the least desirable methods of illustrating a scientific paper; from 15 to 25 per cent. of detail is inevitably lost in the process of reproduction, and the inclusion of inessential details in the background leads to confusion. Line drawings, as has been said, are far better; they should be drawn on a large scale, and can then be reduced during the process of reproduction to a convenient size; the author, however, must remember that any reference letters or numbers will be correspondingly reduced, and therefore should be drawn large. The author should not insert any words in ink on drawings, diagrams or charts; such indications should be put in very lightly in pencil,

allowing a skilled draughtsman to give them their final form.

The concluding section of the Notes deals with scientific names of animals and plants. These names, as is well known, are formed according to the binominal or Linnaean system; for the manner of their use international rules exist, and it is illiterate not to abide by them. The specific name must be written with a small initial letter: thus, *Bacillus typhosus*, not *Bacillus Typhosus*; further, "Specific names should not be employed alone, but should always be preceded by the full name or initial capital letter of the genus to which they belong; for example, write *Bacillus coli* or *B. coli*, not *coli*." This touches on the use of laboratory slang; it may be all very convenient in a laboratory, but it has no general sanction, and may easily be misunderstood by workers in another laboratory, or by those whose laboratory experience has been left some years in the past. In zoological nomenclature specific names should be written with a small initial letter, even when they are formed from names of persons or places—thus, we should write *Trypanosoma brucei*, not *Trypanosoma Brucei*. Unfortunately, the botanist uses an initial capital letter when the specific name is derived from that of a person: for example, he would say *Phlox Drummondii*, not *Phlox drummondii*. Since bacteria are included in the vegetable kingdom, the same convention might be applied to them, but the Medical Research Council expresses the opinion that the specific names of micro-organisms should be written with a small initial letter; for example, *B. welchii*, not *B. Welchii*. Finally, we would quote, since it can neither be improved nor abridged, the concluding paragraph of the Notes: "Generic names are frequently used as common English nouns denoting classes. In such cases the name should be written in roman and not italic type, without an initial capital; for example, 'large numbers of bacilli and amoebae were found in the specimen,' not '... of *Bacilli* and *Amoebae*...' (The latter statement would mean that many different species belonging to the genera *Bacillus* and *Amoeba* were found.)"

PERSISTENCE OF GASTRIC ULCERS AFTER PERFORATION.

It is very generally held that a gastric or duodenal ulcer which has perforated will after operation give rise to no further trouble. The common practice of simple suture of such a perforation is based on this belief. A minority is of the opinion that perforations of duodenal and gastric ulcers do better if a gastro-enterostomy is made at the same time. There can be no denial of the fact that the satisfactory infolding of a perforated ulcer, typically a small perforation in the centre of a relatively large indurated area, leads to a very definite deformity. The wonder is that so many cases should apparently suffer so little physiological upset and actual obstruction following the operation. A certain proportion—and just what that proportion is it would be interesting to know—do suffer from persistent dyspepsia after closure of their perforations. (Two out of Farr's¹ twenty-one patients who recovered after perforation came to gastro-enterostomy for pyloric stenosis.) Lewisohn² discusses this interesting question, and records four cases, seen within two years, in which re-operation became necessary owing to recurrence of symptoms. Of these, two were duodenal, one gastric, the site of the fourth not being ascertainable owing to adhesions. The absence of cure after perforation is well shown by another case, in which an ulcer that had perforated and been sutured gave way a second time,

¹ Farr, C.: *Ann. Surg.*, p. 591.

² Lewisohn, R.: *ibid.*, November, 1920, 595.

necessitating immediate operation. It may be argued that these cases are rare, that the usual post-perforation course is generally much happier and more benign. Lewisohn believes that a gastro-enterostomy at the time of suture obviates these ill results, whilst not in any way reducing the percentage of recoveries. The author has carried out this practice in 8 cases without a death, and refers to Deaver's larger series (25 cases with one death). The surgeon will obviously have to use his judgement in selecting cases suitable for immediate gastro-enterostomy. In cases of perforation seen late, in large perforations with extensive peritoneal soiling, in cases in poor general condition, the old saying of "Quick in and quicker out" is the only possible advice. But in early perforations with limited extravasation of gastric and duodenal contents it will often be well to do a gastro-enterostomy as soon as the perforation has been satisfactorily closed and the ulcer buried. This method of treatment finds its happiest field of application with duodenal and juxta-pyloric ulcers. It is now recognized that ulcers of the stomach at a distance from the pylorus cannot be infallibly cured by gastro-enterostomy. Partial gastrectomy and pylorotomy are the operations of choice here. But he would be a bold man who would perform the last two operations upon patients with perforated ulcers. Such bold men do, however, exist, for Gauthier³ has performed pylorotomy with posterior gastro-enterostomy and jejuno-jejunostomy on a man 56 years old suffering from a perforation, six hours old, of a callous ulcer of the stomach.

THE NEW SERIES OF THE "INDEX MEDICUS."

WITH the appearance of the first quarterly part of the first volume of its third series the *Index Medicus* breaks away from tradition in several respects. Instead of being a monthly *catalogue raisonné* of medical works (books, articles in journals, pamphlets, etc.) with an annual alphabetical index of its own contents, it becomes a quarterly alphabetical list without an annual index, each part being, so to say, its own index. This is the change stated generally, and it would seem, therefore, as if once more the alphabetical index has defeated the *catalogue raisonné*, and remains in possession of the field; but this is not completely so—traces of the subject-arranged system remain, at any rate, for a time. For instance, Dr. Fielding H. Garrison, one of the two editors, in order to orient the reader who is used to the older arrangement, gives a grouping of the various subject-rubrics under such headings as Anthropology, Bacteriology, Biology, Climatology, Dermatology, and so on. This list, which occupies the first two or three pages of the quarterly part, will, it would seem, appear at least for a while, until custom has familiarized the new plan of consultation. In this small alphabetically arranged *catalogue raisonné* there is a sort of rudimentary survival of the prevailing plan with which so many were familiar in the first and second series of the *Index Medicus*. Under "Hygiene," for example, in this small preliminary grouping, there are found the following headings, any one of which may be found in other parts in its alphabetical place: Abattoirs, air, dust, factory workers, flour, food, habitations, health insurance, heating, hygiene (industrial), hospitals, marriage, meat, etc. The editor has thus shown his real desire to prevent any serious jar in the change of gearing in his bibliographical automobile. Further, at the conclusion of each year (four parts), an alphabetically arranged index of authors is to be supplied. Three changes on the title-page accompany these internal rearrangements—the word "quarterly" takes the place of "monthly"—namely, *Index Medicus: A Quarterly Classified Record of the Current Medical Literature of the World*; a joint editor's name appears—namely, Albert Allemann, M.D.; and "third" is found instead of "second" series. Of the change in system J. W. B. sends us some comments

which may be summarized as follows: "The alphabetical system of arranging the subject-rubrics now adopted is not free from inconvenience. Closely related matters are separated sometimes by the whole length of the alphabet, and a remarkably active intelligence is necessary to exhaust all the possible headings under which a reference may reasonably be expected to appear. Then, again, comparatively unimportant subjects have the same largeness of type and amount of space allotted to them as many much more outstanding matters. Some rubrics are almost useless as they stand, such as *Girls (Defective)*, under which one finds a reference to a paper on 'Girl Guides and the Welfare of the Defective Girl'; the mysterious *Orbitopagus* has the same typographical rank assigned to it as, say, *Ointments*; and a paper on *Digestion* is not likely to be looked for under the rubric *Onions*. Every new drug that the chemist finds a name for and that the enthusiastic practitioner gives a trial to at once springs into prominence by the system adopted here. The fact is that modern medicine is a very difficult subject to index, and whilst the method now employed may do away with some of the inconveniences of the former plan, it will introduce others of a new kind. At the same time it makes for rapidity of consultation with perhaps a slight lessening of exhaustiveness in the result obtained; the balance is therefore, perhaps, rather in favour than against the change. There is one distinct advantage: the systems in use in the *Index Catalogue* and in the *Index Medicus* are thus unified. Of these two publications the latter is in a sense the more important, for it gives access to the most recent additions to that storehouse of medical literature. America, the Carnegie Institution of Washington, and the editors deserve well of all English-speaking peoples for providing guides so trustworthy to the literary contributions constantly being made in all lands to the art and science of medicine. To the medical teacher, to the research worker, to the writer of book or article, to the specialist, and to the practitioner who wishes to keep abreast of the times, the *Index Medicus* is the only absolutely complete *vade mecum* to the literature of his subject. By its means, and with access to a good medical library, he may at first hand consult the original papers on any matter which may be exercising his mind. It gives him the titles, and much may be learned even from a title." In this connexion it will not be without profit to quote what Dr. Garrison says about titles. He says, re-echoing a remark made by Dr. Fletcher, at one time editor of the second series, "there are titles which may be unassignable under a strict classification"; and he continues: "this is especially true of titles which have no true centre of gravity—for example, those in which two or more ideas are exploited with equal weight, or in which two or more disparate diseases are brought into causal or other relations, or in which the true intention is not apparent, even from the text of the book or article itself." Editors of medical periodicals know only too well such obscurely named articles, and not a few really important discoveries have been lost to view through such faults in terminology. Dr. Garrison closes his prefatorial notes with a sentence of good advice: "the simple rule of Billings (the first editor of the *Index Catalogue* and *Index*), 'Give the paper a proper title,' commends itself equally to medical authors, editors, and publishers."

THE COCKROACH.

THE latest addition to the series of economic pamphlets issued by the Trustees of the British Museum is that on *The Cockroach*,¹ by Mr. Frederick Laing, Assistant in the Department of Entomology. This disgusting creature, which, as every schoolboy knows, is neither black nor a beetle, and neither cock nor roach, has often been under

¹ *The Cockroach: Its Life-History and How to Deal with It.* By Frederick Laing, M.A., B.Sc. London: Printed by order of the Trustees of the British Museum, and sold at the British Museum and by B. Quaritch, Ltd., and Dulau and Co., Ltd. 1921. (Demy 8vo, pp. 18; 2 figures, 6d.)

³ Gauthier; *Bull. Mém. Soc. Chir. Paris*, October, 1920, 1115.

suspicion as a carrier of disease, but the verdict hitherto has been "not proven," save in so far as it acts as a secondary host to a nematode, *Spiroptera neoplastica*, which in certain circumstances can produce cancer in rats. With this part of the story of the cockroach, which was very fully related in our columns, Mr. Laing does not seem to have made himself sufficiently acquainted. Possibly, however, future research may incriminate the cockroach further, and it seems reasonable to suppose that the creature may infect food over which it crawls. Its only useful functions are that it removes dead animal matter and that it eats bed-bugs. Mr. Laing writes most attractively, and within the compass of 18 pages describes the habits and life-history of the common cockroach, of the misnamed German cockroach, and of the two other species—the American and the Australian—occasionally found in warehouses and hot-houses in this country. The most effective methods of getting rid of these domestic pests are set out in a practical manner in the concluding section. The illustrations could scarcely be bettered.

ABLATION OF OVARIES IN MAMMARY CANCER.

From time to time cases have been reported in which a remarkable retrogression of cancer of the breast has been observed after removal of the ovaries. The earliest cases, so far as we know, were two reported to the Edinburgh Medico-Chirurgical Society by Sir George Beatson in 1896, and recorded in our columns on June 6th of that year. The most recent of the kind seems to be one reported to the Académie de Médecine on March 2nd by Dr. Henry Reynès of Marseilles. He had had a case in which the same treatment was tried in 1904. His new case is that of a woman aged 45, in whom the menopause had not occurred. She was suffering from very advanced cancer of the breast; it was ulcerated and adherent to the chest; there were numerous enlarged glands in the axilla, and great oedema of the left upper limb. The local condition was quite inoperable. The ovaries were removed on October 1st, 1920; improvement immediately began, the ulceration healed, the breast became movable and the axillary glands, as well as the oedema of the arm, disappeared. The general condition, which had been very bad, cachexia being marked, greatly improved. A local operation for the removal of the tumour could have been performed, but the patient is very satisfied with her condition. In his comments Dr. Reynès suggested that in such a case arrest of the ovarian function might be brought about without operation by exposure to x rays.

THE GORGAS MEMORIAL.

SURGEON-GENERAL WILLIAM C. GORGAS, of the United States Army, died at the Queen Alexandra Military Hospital in London on July 4th, 1920. He had been taken ill while passing through this country on his way to the West Coast of Africa to investigate the prevalence there of yellow fever, a disease with which his name will ever be associated. The funeral service was held with full military honours in St. Paul's Cathedral; the body was then conveyed by an American warship to the United States and buried at Arlington, near Washington. In October last we stated that as a memorial to General Gorgas it had been proposed to establish in Panama an international institute for research in tropical diseases. It has now been announced by Rear Admiral Braisted, of the United States Navy, that plans are afoot to broaden the scope of the Gorgas Memorial Institute at Panama, so that it may be a research and teaching institute of international scope. According to our contemporary, the *Journal of the American Medical Association*, three American medical men are about to proceed to Panama to put the plan into effect as soon as the preliminary organization work is complete. The intention is that they shall begin research work in tropical medicine under

the superintendent of the hospital. Later the institute will have its own building adjoining the hospital, in front of which will be erected a statue of General Gorgas. Among the other institutions engaged in teaching and research in tropical medicine which have expressed their willingness to co-operate in furthering the aims of the Gorgas Memorial are Harvard and Johns Hopkins Universities, the Rockefeller Foundation, the University of California, the London School of Tropical Medicine, and the Liverpool School of Tropical Medicine. A more appropriate memorial could scarcely be conceived for the medical administrator who abolished yellow fever and malaria from the Panama Canal zone, and so made possible the construction of the great inter-oceanic waterway.

THE CHINESE RED CROSS SOCIETY.

Among the reports on national Red Cross societies presented to the recent International Conference at Geneva was one on the Chinese Red Cross Society. It is from the pen of Dr. B. Y. Wong, of the medical department of the Central Committee at Peking. It deals with the history of the society during the last ten years. During the first revolutionary outbreak in 1911 funds were raised in Shanghai, and Red Cross detachments were sent to Hankow under the direction of Dr. S. M. Cox, with Dr. B. Y. Wong as his adjutant, and also other centres of revolutionary activity. Another detachment was sent from Peking, under the leadership of Dr. J. C. Ferguson and Dr. Gibb, of Peking Union Medical College. In addition to attending to the wounded and rescuing the inmates of a blind asylum, the detachment raised burial corps, which were of great service. Much Red Cross work was done also at Nanking under the direction of Dr. Osgood. The society was again active during the civil war of 1913; it also came to the rescue of the population during a series of floods, the first due to the overflow of the river Wye, the second of the river Yu, and a third to a very serious inundation of the province of Fengtien. During the great war the society had few opportunities of being useful, but it gave aid during the Japanese operations against the Germans, and also at Vladivostok, where a hospital was established and nearly 17,000 patients treated. In 1918 Admiral Tsai was appointed vice-president, and the reorganization of the society was undertaken, but was interrupted by the call for help during the recent great famine in five densely populated north-western provinces. The society has three hospitals at Shanghai. One of these is the General Hospital, conducted in association with the American missions. It is a substantial building of red brick with stone foundations, on a site about two miles from the business centre of Shanghai. Cases are transported to it in motor ambulances; it is intended for the reception of serious cases, both surgical and medical, and is provided with a good operating theatre. The other two hospitals are on a smaller scale, but between them provide accommodation for over 300 cases. The society also has a small infectious hospital, which is open during the summer when cholera and intestinal disorders are prevalent.

AN ASTHMA CLINIC.

THE report of the Medical Board of the New York Hospital for 1920 states that in March of that year a special out-patient clinic for the study and treatment of asthma and hay fever was opened under the charge of Dr. Robert A. Cooke. This class, which is held twice weekly, has rapidly grown, so that from sixty to eighty patients are now treated at each session, and there is difficulty in providing adequate quarters in the limited space at the disposal of the out-patient department. The permanent value of this work cannot as yet be estimated, but the results so far attained are regarded as most encouraging and in striking contrast to those of former methods of treatment. Working on the assumption that such

conditions as asthma and hay fever are usually manifestations of a peculiar idiosyncrasy or hypersensitiveness on the part of the individual to certain substances taken into the body by inhalation or as food, the first stage in the treatment is the identification of the special substance or substances to which each patient is sensitive. This is accomplished by observing the local effects of the injection of extracts of a great variety of these substances into the patient's skin, in the manner described by Mr. Frank Coke in our issue of March 12th, 1921. If and when the offending agent is identified an effort is made to protect the patient from further exposure to it, or, should this not be possible, to immunize him against it by repeated subcutaneous injections of minute doses of its extract. Nine months' experience at the New York Hospital asthma clinic suggests that in the majority of asthmatic patients the trouble is due to the inhalation of the dandruff from the fur, feather, or hair of domestic animals. The growing work of this clinic has made heavy demands upon the subdepartment of immunology of the Pathological Department for the preparation of extracts of the various substances used in the diagnostic tests. As many as 130 substances are employed, and much skill and ingenuity have been needed to prepare extracts which are not only potent, but sterile and safe for inoculation. The importance attached to environment in the causation of many cases of asthma has led to the appointment of a social service worker to visit the homes and workshops of the patients and aid in carrying out the therapeutic measures advised at the clinic.

THE RÖNTGEN SOCIETY.

THE Silvanus Thompson Memorial Lecture of the Röntgen Society is to be delivered by Dr. A. V. Hill, Professor of Physiology in the University of Manchester, at the annual meeting of the Röntgen Society on May 19th; the subject of the lecture will be "Electrical instruments and phenomena in physiology." The society will hold its first meeting out of London at Manchester on Friday, May 6th, at 8 p.m., when, as already announced, Professor W. J. Bragg, Langworthy Professor of Physics in the University of Manchester, will read a paper, and Professor A. V. Hill will give a demonstration. On the following day visits will be paid to works in the district. The society's annual exhibition will be held at the house of the Royal Photographic Society, 35, Russell Square, during June. Dr. Robert Knox, the president of the society, offers silver and bronze plaques as prizes for the best and second-best collection of four prints, the work of an assistant employed at a hospital or working for a qualified radiologist. This section will be open to persons who are not members of the Röntgen Society. The inaugural meeting of the Institute of Physics, which members of the Röntgen Society are invited to attend, will take place at the Institute of Civil Engineers, Great George Street, Westminster, on April 27th, at 6 p.m. The President, Sir Richard Glazebrook, K.C.B., formerly Director of the National Physical Laboratory, will be in the chair, and Sir J. J. Thomson, O.M., will deliver an address. It is hoped that Mr. A. J. Balfour will be present and take part in the proceedings.

PATHOLOGICAL RESEARCH APPLIED TO MEDICINE.

It has been arranged to give during the summer session a course of lectures at the Institute of Pathology and Research, St. Mary's Hospital, London, on pathological research in its relation to medicine. The first lecture will be given by the Principal, Sir Albroth Wright, M.D., F.R.S., on Thursday next, April 28th, at 4.30 p.m.; subsequent lectures will be given on the same day of the week and at the same hour. Among the distinguished men of science who have promised to take part in the course are Sir James Mackenzie, M.D., F.R.S., Professor W. Bulloch, M.D., F.R.S., Professor G. Dreyer, M.D., F.R.S.,

Dr. Leonard Hill, F.R.S., Dr. H. H. Dale, F.R.S., and Dr. J. A. Murray, Director of the Imperial Cancer Research Laboratories. The course will be open to all members of the profession and students. The full programme giving the subjects of each lecture will be published shortly.

EMERGENCY AMBULANCE PLANS.

IN view of the recent threat of a strike of railway men and transport workers the Home Service Ambulance Committee of the Joint Council of the British Red Cross Society and the Order of St. John instructed the county directors that the fullest use should be made of the ambulances, both for the assistance of the authorities in dealing with casualties and for the maintenance of hospital supplies in the event of the failure of other transport facilities. In the instructions issued as regards the use of the ambulances in connexion with any disturbances, it was requested that regard should be had to the maintenance of the ordinary work of the vehicles, and that such arrangements should be made for co-ordination between adjacent ambulance stations that the least possible inconvenience should ensue to the hospitals and patients of the areas served. It was stipulated, with the concurrence of the military authorities, that the ambulances must remain entirely under the control of the county directors and must not be driven by enlisted men.

DR. HENRY HEAD will deliver the Croonian Lecture before the Royal Society on Thursday, May 5th. The subject is "Release of Function in the Nervous System."

PROFESSOR FREDERICK GOWLAND HOPKINS, M.B., F.R.C.P., F.R.S., who has been professor of biochemistry in the University of Cambridge since 1914, has been appointed to the newly-founded Sir William Dunn chair in that subject. The total amount of Sir William Dunn's benefaction for the establishment of an institute of chemistry was £165,000; of this, £25,000 was set apart for the endowment of the chair, and £10,000 to provide a salary for the second in command; £60,000 was to be spent on the erection of suitable laboratories, leaving, it was hoped, an income of about £3,000 a year for research and upkeep.

OWING to the threatened railway strike the Congress of Radiology and Physiotherapy, which had been arranged for April 14th, 15th and 16th, could not be held. At a meeting of the Executive, held on April 20th, it was decided to postpone the congress until next spring.

Medical Notes in Parliament.

FROM OUR PARLIAMENTARY CORRESPONDENT.

Post-Graduate Instruction.

THE Committee appointed by the Ministry of Health, with the Earl of Athlone as chairman, to consider the question of post-graduate instruction in medicine, has held a number of meetings and is approaching the completion of its work. It is not expected, however, that the report will be ready before next month.

Tuberculosis Bill.

Second Reading in the Commons.

SIR A. MOND, on April 15th, moved the second reading of the Public Health (Tuberculosis) Bill, the object of which is to enable the county and county borough councils to take up, as from April 30th, responsibilities for sanatorium treatment for tuberculosis, this being the date on which the duties of the Insurance Committees in this matter under the National Insurance Act of 1920 are ended.

Minister's Statement.

The Minister reminded the House that the county and borough councils had already been responsible for a large number of tuberculosis cases, and had treated many insured

and non-insured cases within their areas. It was the scheme proposed in the bill that these authorities should act in respect of both insured and non-insured. Arrangements have been made in accordance with schemes or agreements approved by the Minister of Health or his predecessors, and Clause 1 of the bill provided that such arrangements should for its purpose be deemed adequate. Of the 145 county and borough councils in England and Wales 124 have acted, and the bill placed no fresh obligations upon them. Of the remaining 21, all but one had made some provision for the treatment of tuberculosis, but in two or three cases the provision extended only to dispensaries, and in others the arrangements of the councils for treatment in sanatoriums or hospitals did not provide fully for insured persons. In these cases the Insurance Committee at present met directly the needs of insured persons. He understood that the small number of councils who had not yet fallen into line were ready to do so if they understood that the obligations were statutory. In order to prevent the possibility of any local authority failing in its duty, there was a power in Subsection 2 of Clause 1 by which the Minister in such event might make adequate arrangements and charge the authority with it. This power was really a precaution.

Touching on finance, Sir A. Mond said he knew that some doubt had been felt whether the powers given under Clause 2, Subsection 1, might not be used in such a way that if at any time the Exchequer contributions diminished the Minister might impose great burdens upon the local authorities. That was not intended, and if so desired he should be pleased to consider an amendment to remove that doubt. Power was to be given to local authorities to co-opt on their committees members from the Insurance Committees which had been doing such good work. To compel this course to be taken would, he thought, very much defeat the object in view, but he looked forward to invitations being given and to harmonious co-operation. He read a letter he had received from the Association of Municipal Corporations. A subcommittee who had considered the bill accepted the co-option provision only because it was optional. They would, it was stated, strongly object to this provision being made compulsory. Sir Alfred added that some doubt was manifested whether the position of the Welsh National Memorial Association was met under the bill. He was assured that it was, but would be ready to insert any further amendment to make the matter absolutely certain.

Mr. Ormsby Gore, in welcoming the measure, believed that the county and borough councils were willing co-operators but bad servants if the Ministry attempted to drive them. The campaign against tuberculosis required strategy. One of the lacunae was that tuberculosis was notifiable since 1912 to the district medical officer, but he had to pass on his information to the county medical officer, and he had to treat it as confidential. Thus his action was frequently restricted, although he was more responsible than anyone else for administration. It was very desirable to get over this administrative difficulty. After-care also wanted far more attention. The Government would, he was sure, be well advised to encourage the county councils administering the bill and the medical officers of health to stimulate in every way research and reports upon their experience, both scientific and administrative, so as to get every one keen on stamping out a disease of this kind. It was most important that officers who had been engaged in administering sanatorium benefit, with seven or eight years' personal experience of the working of it—medical and lay—should not be suddenly turned off into other occupations. He thought that some indication should have been given in the bill that there would be some continuity of employment, as far as possible, for officers who had administered the benefit in the past.

Debate.

Mr. R. Richardson, on behalf of the Labour Party, also welcomed the bill. As to the scheme generally, he held that matters should not be left so much to the local authorities. This was a national question, and the expense ought not to be thrown on the local authorities. It was broadly correct to say that the poorer the area the more prevalent was this disease and the less able were the people there to cope with it owing to their financial position. The greatest defect of the bill was as regards after-treatment. It ought to be an instruction to every local authority that it must have an After-care Committee. That committee should include upon it the medical officer of the local authority or some such person. Every local authority ought also to provide an open-air school for all children suffering from the disease, where pure milk could be provided.

Lieut.-Colonel Hargrave commended the bill for several reasons, but for two in particular. One was that tuberculosis was preventable and should not exist in any civilized country, and the second was that it was curable. At present there were in England over 600,000 persons attacked by tuberculosis. England alone suffered in deaths between 50,000 and 60,000 persons per year from tuberculosis. He was certain that the health authorities were most anxious not only to give the very best treatment to those suffering from tuberculosis, but to take every possible means, backed up by the Minister of Health, to prevent it spreading. He agreed that the clause to enable members of Insurance Committees to be co-opted should be mandatory and not permissive. Local committees should have the power to appoint an After-care Committee—a statutory committee to see that the patient was enabled to carry on, in some degree, the sanatorium treatment. He suggested that the most important problem was the wage-earning power of the man or woman afflicted. A man attacked by this disease was, in the best of circumstances, only a 50 per cent. man in wage-earning

capacity. Means must be devised by which suitable occupation could be found for those men and women who had to some extent recovered, whereby they could earn a proper livelihood. Another important question was the isolation of advanced cases. One of the chief means by which a reduction of tuberculosis had been brought about was the fact that the Poor Law infirmaries isolated an enormous number of advanced cases. The infirmaries should be encouraged to continue this humane and necessary system of giving comfort and shelter to these afflicted people. There was also the question of sailors; wherever they landed the local authority should have power to give them whatever treatment they might require.

Mr. Trevelyan Thomson hoped that in Committee Clause 1 would be strengthened, for as it was drafted it meant that no matter how inefficient or incomplete an existing scheme might be it was to be deemed adequate after the passing of the bill. Coming to his own experience of work on an Insurance Committee at Middlesbrough, Mr. Thomson said that their funds being so limited they concentrated entirely on early cases, and it was found that 60 per cent. of the patients who had been dealt with were able to resume active work and take their places as physically fit. The advanced cases, notwithstanding that they were ignored, had not increased in number. They found that so far as their limited funds operated, the value of the money spent worked out in these proportions: For every £1 spent on after-care, £2 was spent in the dispensary and £8 upon sanatoriums; in fact, eight times as much value was got for the money spent on after-care as upon other forms of treatment. He appealed to the Minister to extend recognition to convalescent homes, which might not occupy palatial buildings and have a full staff of medical officers and nurses, but which were yielding an excellent return. He hoped, too, that more financial assistance might be given to the local authorities.

Captain Elliot recalled that Scotland had provided the precedent for this scheme—a precedent which had been working for a long time. Quoting the comparative statistics of deaths from tuberculosis and consumption in this country, he thought that a certain amount of the decrease of the last two years was undoubtedly due to the remedial measures introduced by the then Minister of Health, but a large amount of it was due to good trade. He warned all sections of the House—and was sure that every medical man would join in that warning—against the almost inevitable disturbance in our vital statistics which the present industrial crisis would bring about. Our vital statistics were very much better than those of any other country in Europe, and better almost than those of any other country in the world. In 1919 our death rate was 125.8, and in 1920 it was 112.8. In Prague, where the conditions were fairly comparable with those in our own country, the death rate was 386, in the city of Warsaw it was 591, in Vienna 490, and in Cracow 616. We had no special immunity against disease in this country. If we had a starving population, diseases, of which tuberculosis was one, would follow as surely as the rising and setting of the sun. He thought that the scheme of the bill afforded the best method of dealing with the matter. This was by a system of local administration with a grant in aid from a central authority, and it had proved its value in other affairs of public health in the country, as, for instance, in reducing the mortality of children. There was a splendid chance now of dealing with this evil. Influenza had swept out a large number of people who would probably have become acute cases of tuberculosis. Consequently they had a very low number of people in the country to-day actually in acute stages of tuberculosis; they could get it on the run if they could drive the attack home. In regard to after-care, he thought the experience of the Ministry of Labour should be of the utmost value. What was wanted was a sort of disabled men's roll—some sort of national scheme for the reservation of a proportion of places in industry. In this connexion he made a special appeal to the Labour representatives. He suggested also that there should be some sort of a clearing-house system before men were definitely marked off for sanatorium treatment; this would enable the whole medical science to be concentrated on a particular case, and then it could be determined definitely, after some residence in hospital, whether a person needed to start the treatment.

Major Molson hoped that the bill would be passed promptly, and that any great expense in the way of building would be avoided. He was not in favour of elaborate buildings, but of pushing forward to fulfil the pledge given so long ago for the efficient treatment of the great mass of people who needed it.

Major David Davies regretted that there was no financial clause in the bill. He thought it was intended that the financial arrangements which would come up in the Estimates for the Ministry of Health were to be based on the present arrangement. The local authorities paid 50 per cent., or half the deficit, and the remaining half was to come from the Treasury. He urged that the Treasury contribution should be two-thirds.

Major Newman agreed that the measure was necessary, but asked what it was going to cost the tax- and rate-payer.

Dr. Farquharson welcomed the bill, which he took as dealing solely with the question of institutional treatment for tuberculosis. As he read the finance of the bill something more than £400,000 would be available for the purpose. In his view sanatorium treatment at present was nothing more than an experiment. In his opinion the spending of large sums of money on institutional treatment was neither wise nor justified by the results of the past; it was only one of the whole gamut of methods of treatment; it was only one little stage of treatment which often came in, unfortunately, when treatment of any kind was more or less useless. He regarded the sanatorium

as an element of an educational agency, which the Ministry of Health now had at command. The Ministry had a duty more important than merely creating bureaucrats to dispense large sums of money. One fault he found with institutional treatment was that it induced a certain degree of passivity on the part of the patient. The After-care Association encouraged that passivity, when often all that was wanted was to rouse the patient to the knowledge that he was his own keeper, and that by simple attention to hygienic rules he could cease to be a burden upon his fellow men. Referring to the financial statistics of the bill, Dr. Farquharson pointed out that it transferred the onus of the incidence of payment for benefit given. Under the National Insurance Act the benefits derived from institutional treatment were paid for by the employers, by the State, and by the insured person himself, a portion of the contributions being allocated. Under this bill by a stroke of the pen the onus referred to was transferred to the local ratepayer and the income tax payer, the money previously applied for this purpose being absorbed in general insurance benefits. He thought that such financial readjustments should not appear as a side issue. He was opposed to the suggested amendment to compel county councils to co-opt members of committees; that this should be permissive was right and proper. Subject to these criticisms he welcomed the bill as filling up a gap left by the bill of 1920.

Mr. Lane-Fox, Sir W. Joyson-Hicks, Sir F. Blake, Sir F. Banbury, Lieutenant Commander Kenworthy, and Mr. Myers continued the discussion.

Sir A. Mond, in replying on the whole debate, said the total expense of the treatment of tuberculosis was estimated at £2,300,000, of which the Exchequer was bearing £1,300,000 and the local authorities were bearing £1,000,000. Another £100,000 had to be added to the Exchequer expenditure because that was the sum which would come on the Exchequer which was now being borne by the insurance vote. What was now being discussed was £300,000, which was not a fixed amount but an approximate amount. It was the contribution which would have been received from the Insurance Committees by the local authorities. The local authorities were actually receiving from the Exchequer the full equivalent of the amount available in 1920. The sum of £300,000 was to be taken as an estimate. The proper time for discussing the financial aspects of the bill would be on the Estimates. Lieut.-Colonel Fremantle inquired if the proposals of the bill of last year dealing with sanatoriums for soldiers in village settlements would be included in this bill. Sir A. Mond said they certainly would not.

The bill was then given a second reading.

The Dogs Bill.

One effect of the preoccupation of parliamentary minds with the coal crisis was that, the business of the House of Commons being taken as usual, there was a chance that the bills of private members on the agenda for April 15th must be passed at a rapid rate and without much attention being given to them. The medical group, however, kept a vigilant eye for the Dogs Bill introduced by Sir Frederick Banbury, which was down for second reading as a late order. The withdrawal of various members from the debating chamber at one o'clock ensured a count and an adjournment until half-past three. Then the House received the important statement by the Prime Minister regarding the coal conference and no further business was taken.

The Medical Staff of the Ministry of Health.—Sir A. Mond, in answer to Sir T. Fraser, said, on April 13th, that the total number of medical men on the staff of the department (including two part-time specialist officers) was one hundred—namely, sixty-three at headquarters and thirty-seven in regional offices; the salaries of the headquarters on March 31st, 1921, amounted to £51,549 3s., and the war bonus to £31,681, a total cost of £83,230 3s. per annum. The salaries of the regional medical officers, as on March 31st, 1921, amounted to £47,400. The salaries of these officers were inclusive of war bonus. The number of medical men employed by the Local Government Board in 1914 was thirty-one, and their actual salaries in that year amounted to £20,571 15s. 9d. For purposes of comparison, however, the medical staff of the National Health Insurance Commissions (England and Wales) must be added to this, as their functions are now performed by medical officers of the Ministry. In 1914 this staff numbered eight (including the deputy-chairmen in England and Wales), and their salaries totalled £6,500. The total number of medical men in the two departments in 1914 was, therefore, thirty-nine, and the cost £26,871 15s. 9d. Sir W. Joyson-Hicks asked if there was any intention to reduce what was apparently an over-weighted staff to the pre-war number. Lieut.-Colonel Fremantle inquired whether it was not the fact that this staff had always been insufficient for protecting the health of the nation. Sir A. Mond replied that he had not had an opportunity of going into the question, and could not therefore offer any opinion in regard to it.

Superannuation of Islington's Medical Officer.—Lieut.-Colonel Fremantle asked, on April 13th, whether the Islington Borough Council was proposing to superannuate their medical officer of health after thirty-nine years' efficient and energetic service (twenty-nine at Islington, at a rate not fixed by scale

and far below that usually granted to executive officers. He put it to the Minister that the Superannuation (Metropolitan) Act, 1866, provided for the payment of superannuation at the rate of one-sixtieth of salary for every year of service, and that the Islington Council had adopted the act for superannuating roadmen, scavengers and other labourers. Sir A. Mond said he was making inquiries into the case.

Public Health Officers (No. 2) Bill.—This measure was read a second time on April 14th and committed to a Standing Committee. This is the bill introduced by Sir Philip Magnus at the request of the British Medical Association, and is designed to give all medical officers of health and sanitary inspectors security in their tenure of office similar to that enjoyed by Poor Law medical officers, metropolitan medical officers of health, and medical officers of health appointed by county councils.

Criminal Law Amendment Bill.—Mr. Chamberlain, replying to Lady Astor on April 12th, said that if he found that the Criminal Law Amendment Bill could be treated as a non-controversial measure the Government would endeavour to facilitate the passage towards the end of the session.

Encephalitis Lethargica.—Sir A. Mond, on April 13th, informed Mr. Gilbert that 1,572 cases of encephalitis lethargica had been reported in England and Wales, between April 1st, 1920, and March 31st, 1921. The deaths from this disease during the same period, so far as was known at present, amounted to 495. The disease was made compulsorily notifiable on January 1st, 1919, and since then special reports had been received from medical officers of health on practically all the cases which had been notified, while special inquiries had been made and advice had been given by medical officers of the Ministry in suitable cases. Simultaneously the pathology of the disease was being studied in association with the Medical Research Council.

Admiralty Surgeons' Fees.—Mr. Amery informed Captain Elliot that the revised scales of fees for Admiralty surgeons had now been promulgated in a Fleet Order, with the exception of those for medical examinations.

Bellahouston Hospital, Glasgow.—In reply to questions by Mr. Maclean, on April 14th, as to allegations against the administration of Bellahouston Hospital, near Glasgow, the Minister of Pensions said that he had called for an immediate report, and that unless the report satisfied him that the allegations were unfounded, he would hold an inquiry into the administration of the hospital forthwith.

Medical Officers' Pay in India.—In answer to Lieut.-Colonel Guinness, on April 14th, Mr. Montagu said that the pay of R.A.M.C. officers in India was increased in March, 1920, with effect from July 1st, 1919. Consequent on an increase of pay granted to officers of the Indian Medical Service, with effect from January 1st, 1920, a further increase had been granted to R.A.M.C. officers, with effect from the same date.

Nurses' Registration Acts.—Mr. T. Griffiths asked, on April 13th, whether the General Nursing Council for Scotland had so far refused to consult with the English Council before making rules with respect to conditions of admission to the register, as required by the Scottish Act, Section 3, Subsection (3); and, if so, whether he would insist on such a consultation so that the English Council may be in a position to present its rules for his approval, and to open the register under conditions securing a uniform standard of qualification in all parts of the United Kingdom, as provided in the Nurses' Registration Acts. Sir A. Mond replied that he understood that the Scottish Nursing Council had not refused to consult with the English Council; but that, in view of the small number of outstanding points on the rules for the admission of existing nurses to the register, had suggested that the conference should be deferred until the draft rules for the admission of future nurses were ready for discussion. In any case he had no jurisdiction over the Scottish Council, though he agreed that it was important to secure a uniform standard of registration in all parts of the United Kingdom.

The Dentists Bill.—Mr. Raffan asked, on April 13th, if it was still the intention of the Government to introduce a measure this session to carry out the recommendations of the Departmental Committee on the Dentists Act. Sir A. Mond said he was afraid that, owing to the congestion of the Government's business, legislation on this subject would not be practicable during the present session. Mr. Raffan recalled that Dr. Addison had promised that a bill should be introduced if there were general agreement, and he asked whether on such assurance the present Minister of Health would reconsider the matter. Sir A. Mond said he had no intention to introduce a bill this session. The programme of legislation was very much upset already, and he was informed there was very little chance of any agreement. He would, of course, be glad to look into the matter again, but he did not know how any group of members could give him an assurance of an agreement, and he was sure that the House did not want an autumn session. He would be pleased, however, to receive representations from members of Parliament regarding the position. Arrangements have been made for a meeting one day next week of the Parliamentary Medical Group and of members of the Incorporated Dental Society to consider what steps can be taken to assist the progress of the bill. Captain Elliot and Mr. Raffan are making the arrangements.

THE MALE VENEREAL CLINIC AT THE ROYAL INFIRMARY, LEICESTER.

AN ACCOUNT OF ITS ORIGIN, DEVELOPMENT, AND WORK.

BY

HENRY J. BLAKESLEY, F.R.C.S.,
MAJOR R.A.M.C.T.

HONORARY CONSULTING SURGEON, LEICESTER ROYAL INFIRMARY;
MEDICAL OFFICER IN CHARGE OF THE MALE VENEREAL CLINIC, LEICESTER ROYAL INFIRMARY.

The clinic for diagnosis and treatment of venereal diseases in the male was opened at the Royal Infirmary, Leicester, on March 2nd, 1917. A portion of the out-patient department was set apart by the board of governors of the infirmary. Certain fixed days and hours were allotted, at which times no other out-patients attended, ensuring as far as possible privacy for patients suffering from or seeking advice regarding venereal diseases. A consulting room, two examination rooms, and an irrigation room fitted with sterilizer, hot and cold water, sink, etc., were available.

As the out-patient department is congested with general medical, surgical, and special work no further time can be allotted for extending the number of hours of the venereal clinics. Plans have been prepared and a new building exclusively reserved for the treatment of venereal diseases will shortly be erected. Complete privacy will be secured and all facilities afforded for the carrying out of all ordinary and special treatment under the most favourable conditions.

About the end of 1917 two small wards, accommodating four in-patients, were provided and equipped by the infirmary authorities for men, completely isolated from the general hospital, and they have been in constant occupation up to the present time.

Two clinics of two to three hours each in duration were held weekly during the year 1917. On January 1st, 1918, three clinics a week were deemed necessary, one of which was reserved exclusively for the treatment of gonorrhoea; and on November 1st, 1919, it was found that the holding of a fourth clinic per week was essential in order to cope with the number of patients applying for treatment, this being more than double that of the preceding year.

During the first year the staff consisted of the medical officer in charge—who personally carried out the whole of the treatment, both general and technical—assisted by an inadequately trained male nurse. About the middle of 1918 one of the resident house-surgeons of the infirmary was allowed to assist at two clinics per week, and his services were utilized to carry out the technical treatment of gonorrhoea. This arrangement obtained until July, 1919, when the largely increased number of patients attending rendered it necessary that the house-surgeon should attend all the clinics. After a few months it was found that his attendance at all clinics so materially interfered with his ordinary duties as house-surgeon that the board of governors, with the approval of the Ministry of Health and the City and County Councils, appointed a fully qualified medical man as part-time assistant medical officer to the Male Venereal Department.

The two medical officers carry out the whole of the work of the department, assisted by a highly efficient male nurse and a well trained hospital porter. In addition to his duties at the clinics the male nurse is in nursing charge of the male venereal wards, and he is on duty from 8 a.m. to 8 p.m. for the carrying out of measures (for the prevention of venereal disease) and the giving of irrigations to such cases of gonorrhoea as apply in the intervals between the hours of the recognized clinics.

Summary of Work Done.

The work done in the three years and four months from March 1st, 1917, to June 30th, 1920, comprises:

1,885 new patients, 628 of whom were suffering from syphilis and 1,052 from gonorrhoea; 205 were found after clinical and bacteriological examinations not to be suffering from venereal disease, and 86 were proved to be suffering from both diseases.

Renewed attendances numbered: In 1917, 2,583; in 1918, 5,021; in 1919, 9,315; and in 1920 (six months), 5,942.

During the ten months of 1917, 287 new patients applied for treatment at the clinic, 97 proving to be suffering from syphilis and 161 from gonorrhoea.

During the year 1918, 360 new patients applied, 121 suffering from syphilis and 210 from gonorrhoea.

During the year 1919, 852 new patients applied, 266 suffering from syphilis and 495 from gonorrhoea.

During the first six months of 1920, 386 new patients applied, 144 suffering from syphilis and 186 from gonorrhoea.

In about 10 per cent. of the totals venereal disease was not proven, and some 5 per cent. were proved to have both syphilis and gonorrhoea.

The marked increase of new patients during 1919 may be attributed to the fact that in that year large numbers of men were demobilized, many of whom contracted venereal disease shortly after resuming civil life, and a considerable number were cases contracted whilst on active service which had been treated but still showed definite signs of active disease. The renewed attendances of patients coming for treatment have increased practically in proportion to the number of new patients.

Throughout the clinic the strictest antiseptic precautions are observed. All patients are enjoined to observe the following general rules of life during treatment:

No alcohol: total abstinence from coitus or sexual excitement: care and discretion in dietary: careful attention to action of bowels to ensure free daily evacuation; outdoor and healthy exercise, with specified limitations; avoidance of over-heated and overcrowded places (cinemas, music halls, billiard rooms, etc.); early hours to ensure sufficient rest; general bodily cleanliness and sufficient and warm clothing.

Specimens, such as smears, blood for Wassermann test, serum for examination, spirochaetes, etc., are taken from all patients on admission, and are repeated at short intervals during the course of treatment. All specimens are submitted to the pathologist attached to the infirmary for examination and report, and the clinical treatment is controlled and modified in detail by such pathological report.

Treatment of Syphilis.

The treatment of syphilis, as carried out in the clinic, consists of weekly injections, intravenous injections of salvarsan substitute alternating with intramuscular injections of metallic mercury.

Neo-kharsivan is the substitute now exclusively given, others having been tried and discarded as not proving so satisfactory, and the mercury is given in the form of Lambkin's cream. Ten injections of each constitutes a course. The usual doses given are neo-kharsivan 0.6 gram (making 6 grams in all for a course) for an adult patient of average weight and condition. Smaller doses are given in cases of youth, under weight, old age, deterioration of arteries, and in the constitutionally feeble. Larger doses, namely, 0.75 gram, and 0.9 gram, are administered to others of more than average weight, height, and robust constitution; and metallic mercury 2 grains, making 20 grains for the course.

In addition to the above, mercury is given internally by the mouth in the form of pil. hyd. creta grains 2 twice a day.

The gravity method is employed for the administration of salvarsan substitutes, the apparatus consisting of a simple glass container, rubber tubing with glass window, and Bailey's holder and needle. The vein of choice is the median cephalic; Lambkin's cream is given with a Record syringe with a steel intramuscular needle of at least one and a half inches in length. This is given in the buttock, the site chosen being the intercellular tissue between the glutei muscles.

All apparatus employed is sterilized by boiling, a fresh needle which has been immersed in spirit after boiling being used for each injection. The skin is rendered aseptic by tincture of iodine or 2 per cent. watery solution of picric acid. The efficiency of the antiseptic precautions observed is proved by the fact that in 6,236 injections not a trace of sepsis has occurred.

Treatment after Course.—At the end of the course as described all treatment is suspended for five weeks, and at the end of that time the blood is taken and a Wassermann test is done. If the result be negative, pil. hyd. creta grains 2 is given twice daily for one month, and then stopped for one month, at the end of which a second Wassermann test is done. If this also prove negative the pills are repeated for one month, stopped for two months, and a third Wassermann done. Should this also prove negative, the pills are repeated for one month, stopped for two months, again repeated for one month, again stopped for two months, and a fourth Wassermann test is done. Should the patient's blood still remain negative no further treatment is given, but Wassermann tests are performed at intervals of three to six months until after two years from the termination of treatment by injection. If the result of any Wassermann test after the first course of treatment prove positive the patient is given pil. hyd. creta grains 2 twice a day, and after an interval of two months from the last injection of salvarsan substitute a second course is administered, the dosage being the same, but the number of doses varying according to whether the Wassermann reaction shows a low or high degree of positivity. At the end of the second course the same procedure is followed as after the first. Should any further positive Wassermann occur a third and, if necessary, a fourth course is given.

Tests of Cure.—The standard test of cure for syphilis adopted in the clinic is: In cases that commence treatment within two months of the appearance of the primary sore, negative Wassermann tests repeated at intervals, extending to two years from cessation of treatment with the absence of all objective symptoms. In cases commencing treatment after a

longer period than two months from the appearance of sore. negative Wassermann tests repeated at intervals for three or even four years after cessation of all treatment.

Treatment of Gonorrhoea.

The methods adopted for treatment of gonorrhoea comprise irrigations, instrumentation, massage, etc., at the clinics, carried out entirely by the medical officer, and home treatment in the intervals of attendance at the clinics by the patient himself, as instructed by the medical officer, together with the administration of suitable internal medication. Every facility and encouragement is given for gonorrhoea patients to attend daily for irrigations, but as practically all patients continue in full work during their course of treatment it is in most cases impossible for them to attend more than once or twice a week, and home treatment by syringe is ordered: all patients are individually instructed in the method to be carried out.

Each patient is provided with a half-ounce glass syringe and a bottle of solution of potassium permanganate, which, when mixed as directed, equals 1 in 4,000. This he is instructed to use in the following manner:

Wash hands; wash penis; pass urine; mix lotion; fill syringe; inject half a syringeful into urethra and retain half minute; inject remaining half syringeful, and again retain half minute. This method of using syringe is repeated thrice, resulting in 2 drachms of the lotion being injected into the urethra (six times at each sitting).

The whole of the above formula is to be carried out three times a day. The patient is further advised to wash the penis with soap and water four or five times a day. In addition he is advised to drink three pints of water daily; abstain from horse riding, cycling, motor cycling, football, and all violent exercise during the acute and subacute stages; observe great care by washing of the hands after each manipulation of the penis, to prevent infection of his own eyes; and take all precautions against conveyance of the disease to others by using separate towels, etc.

During the period March 1917 to June 1920, 14,311 irrigations were given for gonorrhoea, of which approximately 20 per cent. were irrigations of the anterior urethra only, and 80 per cent. irrigations of the anterior and posterior urethra. In addition to irrigation, further methods of treatment in the form of penile and prostatic massage, passage of metal sounds, instillations of solutions of silver compounds, etc., were given when indicated by the objective symptoms in each individual case. Urethroscopic inspection and dilatation with Kollmann's dilator has been practised in a comparatively small number of cases, but owing to the limited periods during which the out-patient department is available, it has been found impossible to apply these methods of treatment to many cases for which it would probably have been beneficial. Autogenous vaccines have been prepared and administered in a few selected cases of chronic gonorrhoea without evident benefit.

Irrigating Solutions.—The solutions used for irrigations were pot. permang. in strengths of 1 in 6000 for acute to 1 in 2000 for chronic cases. Solution of oxycyanide of mercury, strength 1 in 2000, and hypertonic saline solutions were also used for chronic cases. All solutions were freshly made and were maintained at a temperature of about 104 F., a thermometer being used to check this.

Standard of Cure.—The standard of cure adopted in the clinic for gonorrhoea is: Three negative smears in which neither gonococci nor pus cells can be found, taken at intervals of a month after all treatment has been discontinued, with an absence of all objective symptoms for three months. Such smears having been taken after thoroughly cleansing the glans, prepuce and meatus with spirit, and thorough and careful massage of the prostate for two minutes. The patient is instructed to hold his urine for at least four hours before presenting himself for test.

Clinical Effects during Treatment of Syphilis.

In 762 cases diagnosed as true syphilis, 7 cases of dermatitis, 8 cases of jaundice, and 1 of haemoptysis occurred. Of these, 4 cases were admitted to the wards, 2 being cases of jaundice in a severe degree and 2 of general and severe dermatitis. All have recovered. The two cases of dermatitis have given negative Wassermann reactions up to the present date. The remaining cases were trivial, not entailing discontinuance of their employment. They quickly recovered under suitable medical treatment.

Complications of Gonorrhoea.

The following complications of gonorrhoea were observed in patients applying for treatment:

Epididymitis, 5; rheumatism, 4; stricture, 4; paraphimosis, 4; acute prostatitis, 2; perineal abscess, 2; warts, 2—total, 23.

The following complications arose during treatment:

Epididymitis, 10; retention of urine, 1.

These figures summarized show that all complications arising both before and during treatment amounted to 3.23 per cent. of cases of gonorrhoea: that the percentage of cases of epididymitis occurring in treated and untreated cases of gonorrhoea amounts to 1.45, whilst cases of epididymitis occurring after treatment had been commenced amount to 0.95 per cent.*

Comparison of Civil with Military Practice.

Patients under discipline and control are confined to hospital, and to bed if necessary, thus avoiding the conditions and actions detrimental to recovery, such as alcohol, sexual indulgence, violent exercise, unhealthy surroundings, etc. Nearly all civil patients are compelled by force of circumstances to continue their employment, whether detrimental or otherwise to the course of their disease. Furthermore, whilst military patients are compelled to continue treatment until discharged, out of 1,913 civil patients treated at the Royal Infirmary, no less than 1,035 discontinued treatment voluntarily, and out of this latter number, 303 made less than four attendances at the clinic.

The incidence of attendance is made more difficult in the provincial towns as compared with metropolitan areas by reason of the fact that the workers live and work in close relation with each other, and are known to each other to a much larger extent than in London, where a very large proportion live at a considerable distance from their work, and consequently can attend the provided clinics with greater privacy.

It will be observed that in the foregoing account of the work carried out at the Male Venereal Clinic of the Leicester Royal Infirmary no attempt has been made to show results from the standpoint of cure. This is intentional for the following reasons:

1. The increased and increasing knowledge of these diseases has proved their intractability, and consequently the period of three and a half years is too short to enable one to be dogmatic.
2. Large numbers of patients voluntarily ceased attendance, and it may be presumed that the greater proportion of these did so because all signs and symptoms of their disease had disappeared, though no opportunity was given for further bacteriological examination to verify the fact of recovery or otherwise.
3. The adoption during the past eighteen months of many methods of treatment which have now become recognized as routine practice, which in the early days of the clinic were in a more or less experimental stage, will undoubtedly tend to produce effective results in the near future, but they have not been in operation long enough to warrant definitely reliable statistics.
4. In civil life no means exist of ensuring regular and constant attendance for treatment and examination; by this alone can cure be reasonably expected in the majority of cases.

An extremely gratifying feature of the clinic is the large voluntary attendance of old cases for regular treatment, an attendance which is increasing month by month. Many of the men come long distances, even as much as fifteen to twenty miles, at considerable expense to themselves, both in money for train fares and time for treatment once a week, and in many cases still more often; whilst large numbers of the cases resident in the town attend every day the clinic is open.

The men rapidly show a very marked improvement in general health, and the clinical and bacteriological signs show very encouraging results, although not yet definite enough to give statistics. The appointment twelve months ago of a permanent assistant medical officer, who is devoting his whole time to venereal work, has been followed by very happy results. As stated above, his services at the clinic are utilized chiefly in the treatment of gonorrhoea, and since his appointment all technical treatment for this disease has been personally carried out by him or by myself. The men attending show their appreciation of our efforts, and the congenial tone which pervades the clinic has been considerably promoted and sustained by the loyal support I have received from Dr. Atkinson, my assistant medical officer, and the lay assistants. I am also greatly indebted to Dr. Atkinson for the collating of detailed figures and other work in the compiling of this paper. If these clinics are to be successful in attracting the continued attendance of patients until they become non-infectious, it will be due to the painstaking application by the medical officers of all technical treatment prescribed and the development of a tone of confidence and privacy.

* In an analysis of 50,000 cases of gonorrhoea published in Dr. Lumb's recent work the total number of all complications was 7 per cent. approximately; of cases of epididymitis, 5.5 per cent.; and of epididymitis after treatment commenced, less than 2 per cent. (1.83).

England and Wales.

STREET ACCIDENTS IN LONDON.

THE usual quarterly return has been issued by the Home Office showing the number of accidents to persons or property known to the police to have been caused by vehicles or horses in the streets in the metropolitan area during the year 1920, and stating the number of persons killed. The figures are analysed according to the type of vehicle causing the accident, and the respective quarter in which they occurred. During the year 657 persons were killed, of whom 564 were killed by mechanically-propelled vehicles, 72 by horse-drawn vehicles or horses, and 19 by pedal cycles. Mechanically-propelled vehicles used for trade and commercial purposes were responsible for 216 deaths, private motor cars for 166, omnibuses and trams for 120, motor cycles for 33 and motor cabs for 27. The total number of accidents to persons or property during the year was 49,824. Of these more than 18,000 were caused by trade and commercial vehicles of one kind or another and 9,683 by private motor cars. The last quarter of the year was the least fruitful in accidents, fatal or otherwise. The horse, unaccompanied by any vehicle, was implicated in 151 accidents to persons or property, with a toll of three deaths. The traction engine was even less destructive, producing only forty-three accidents and two deaths. Horse-drawn omnibuses and trams have blank entries in every column from which it may be inferred that they are now extinct in the metropolitan area; but the horse drawn cab is debited with eighty-one non-fatal accidents, and the brougham with 376 accidents and one death.

LIVERPOOL HOSPITAL FOR CHILDREN.

The report for 1920 of the Liverpool Hospital for Children at Leasowe gives some interesting statistics of results. A criticism which is often passed upon statistics from such a hospital is that they are of little value unless followed by others showing the condition after a considerable period of time of those cases which have been discharged under the heading of "disease arrested." Dr. Hartley Martin, senior medical officer of the hospital, undertook, therefore, to follow up the Liverpool cases after discharge, and in order to do this an after-care clinic, held once a week, was established. Of 84 cases discharged "disease arrested" in 1919, 80 were traced, and of the 5 in January, 1921, 75 were well and 5 had shown recurrence of the disease. Of the 75 cases, which comprised cases of tuberculosis of the spine, hip, knee, and tuberculous osteitis, adenitis, and peritonitis, all but one were either attending school or in healthy employment, none of them being in special homes or workshops for the crippled. Such figures are distinctly encouraging in the treatment of surgical tuberculosis.

LEICESTER ROYAL INFIRMARY.

This year is the one hundred and fiftieth anniversary of the foundation of Leicester Royal Infirmary, and in the annual report for 1920 the rapid progress of the hospital during the last two decades is surveyed. This year the building of a new wing of the hospital with accommodation for 93 in-patients has been begun; when this is completed the available accommodation will be approximately 400 beds; to accommodate the necessary number of additional nurses a new wing is being added to the nurses' home, containing 66 bedrooms. During 1920 a special orthopaedic department and a new pathological department were opened, so that it is evident that the administration of the Leicester Royal Infirmary is both energetic and enterprising, and has brought the institution well into the front rank of modern hospitals. The report points out how admirably Leicestershire is situated to inaugurate a scheme of medical service such as was foreshadowed in the report of Lord Dawson's committee. The populous centres of the county are, generally speaking, about equidistant from Leicester, and a satisfactory motor ambulance service would quickly link up the county institutions with the county hospital. The board indicates its readiness to

consider this important question if the county areas appear to consider the co-ordinated service would be a benefit to the community. In regard to the finances of the year the large part that is played in regard to the financial side of the Leicester Royal Infirmary by its Hospital Saturday Fund is well known, and the report draws attention to the fact that whereas last year this Fund amounted to over £20,000, this year it reaches the total of no less than £32,666. In view of the many difficulties of these times the Board of the Leicester Royal Infirmary must be congratulated on being able to present a satisfactory account of its finances, with no diminution, but rather an increase, of its activities.

POST-GRADUATE STUDY IN BRISTOL.

In connexion with the University of Bristol post-graduate studies a series of weekly clinical demonstrations will take place, during May and June, at the Bristol Royal Infirmary and General Hospital alternately on Wednesdays from 2.30 to 3.30 p.m. The demonstrations will include medical, surgical, eye, and skin cases, and the fee is two guineas, which will include admission for instruction for one month to all the departments of the clinical institutes included in the University. In addition, other post-graduate facilities are available in Bristol, since qualified medical practitioners may be appointed as clinical assistants in all branches of hospital practice for a period of one or more months, at a fee of three guineas a month; where the practitioners are unable to attend daily for a month they may extend the thirty attendances over any period up to six months. Inquiries and applications for admission should be addressed to the Director of Post-Graduate Studies (Clinical Section), Pathological Department, University of Bristol.

Scotland.

STUDENTS' FEES AT GLASGOW.

THE report of the Business Committee of the General Council of Glasgow University, which will be presented to the half-yearly meeting next week, makes special reference to the question of raising the class fees of students. As already announced in this column, the University Courts have agreed that the increases shall, as far as practicable, be uniform in the four Scottish universities, and notice has been given that the new scale of fees will come into operation at the beginning of the October session. The adjustment of the scale of increases in the University of Glasgow is at present under consideration by a committee of the Court. The coming into operation of the new scale will, it is said, raise a serious problem in connexion with the grants made by the Carnegie Trustees towards the payment of students' class fees. "The conclusion can hardly be avoided that there are students taking advantage of the Trust whose circumstances do not warrant assistance being given." The suggestion is made that it might be well to revise the basis of the grants in each faculty, and "unless very strong reason can be given, the benefit of the Trust should not be given to anyone who has not gained the leaving certificate or passed the preliminary examination." At the beginning of the academic year 1920-21 the Business Committee reduced by £1 in each faculty the scale of allocation.

FERGUSON CHEMICAL LIBRARY.

On the recommendation of the Library Committee, the University Court of Glasgow has decided to acquire the valuable chemical library of the late Professor John Ferguson, who for more than forty years held the chair of chemistry in the university. The chemical section of the library contains, in round figures, 9,300 volumes, 1,400 pamphlets, and 300 manuscripts. In addition to the great number of volumes on alchemy, chemistry, astrology, folklore, etc., and on technical processes, there are works on early medicine and pharmacy, and on spas and mineral waters. Lastly, it should be noted that the library contains some 130 copies of books printed in the fifteenth century.

Correspondence.

THE SCIENCE OF ETIOLOGY, OR THE NEW EPIDEMIOLOGY.

SIR,—Since "not inquiring too strictly into the specific differentiae of disease" means nothing more than the study of etiological momenta common to disease groups, Dr. Greenwood is to be congratulated on having cleared up a misunderstanding. As regards the final paragraph of his letter in your issue of April 16th, I would venture to remind him that the problem of causation is assuredly not of less interest to the clinician and to the bacteriologist than to the investigator, however hard-working, who devotes himself to the study of epidemics. Preventive medicine is the pride and aim of us all, and contributions to the growing science of etiology, upon which it is based, cannot be too closely scrutinized.—I am, etc.,

April 17th.

THE BACTERIOLOGIST IN QUESTION.

"ETHANESAL" OR ETHER.

SIR,—I used this new anaesthetic, "ethanesal" (BRITISH MEDICAL JOURNAL, April 16th, 1921, p. 565), recently in a case of hysterectomy. The patient was a nullipara and a good subject for the anaesthesia, which was preceded by a hypodermic injection of morphine gr. 16, with atropine gr. 1/50, forty-five minutes before the operation was timed to begin. Anaesthesia was begun with a mixture of chloroform and ordinary ether in equal parts for three minutes and continued with ethanesal on an open mask covered with eight layers of gauze kept covered with a twofold towel. She was ready for the surgeon in seven minutes: the operation did not, however, begin for another five minutes, so that when he began she had been having the anaesthetic for fifteen minutes and was apparently deeply under. During the opening of the abdomen the anaesthesia was satisfactory, but from then onwards I found it very difficult to keep her in a state of real surgical anaesthesia; even by using 1 oz. every five minutes I could not secure quiet breathing and full muscular relaxation, so that after fifteen minutes I changed to ordinary ether, when both these conditions were easily realized and kept for the rest of the operation. My first impression, therefore, of the choice of ethanesal or ordinary ether is that I shall prefer the latter for the following reasons: (a) Ethanesal anaesthesia would be too light for abdominal and rectal anaesthesia; (b) it would be nearly twice as costly as ether; and (c) post-operative vomiting is rarely troublesome with open ether anaesthesia.—I am, etc.,

C. CHARNOCK SMITH, M.R.C.S., L.R.C.P.

Hastings, April 18th.

EVOLUTION AND DISEASE.

SIR,—Dr. J. T. C. Nash's letter on Evolution and Disease, in the BRITISH MEDICAL JOURNAL for April 9th, is an opportune appeal to biologists, and more particularly to bacteriologists, for greater tolerance towards those who make what Tyndall would have termed a scientific use of the imagination in their dealings with the problems of science.

Intolerance and bigotry are out of place in any department of science, but especially in medical science, whose workers are, or should be, familiar with, and therefore sympathetic towards, the little weaknesses of human nature. Certainly as a class scientific men are less bigoted and more tolerant than any other class, despite the tendency of specialization to produce that type of mind that cannot see the wood for the trees, but now and again they allow the cloven hoof of bigotry and intolerance to appear. Two notable and very relevant examples of this deplorable phase of mind may be recalled. When Professor Tyndall, in his lectures on "Dust and Disease," suggested that atmospheric micro-organisms might be agencies in the production of disease, he excited the wrath and jealousy of medical men, who apparently resented the incursion of the pure physicist into the realms of medicine. In a leading article in the *Lancet* a writer thus fanned his displeasure:

"It is lamentable that an eminent public teacher, when speaking on a subject of which he can know next to nothing, should place his opinion in opposition to that entertained by all those who are most capable of judging."

Again, when Charlton Bastian, himself a distinguished Fellow of the Royal Society, submitted to the society a paper dealing with abiogenesis, not only was the paper declined but the particular member of the committee responsible for its rejection flatly refused to look at the specimens Dr. Bastian had brought.

I quite agree with Dr. Nash's general contentions concerning a probable relationship between certain diseases and a faculty of involution and evolution on the part of the causative micro-organisms. In the BRITISH MEDICAL JOURNAL for October 14th, 1905, I published the case of a robust and temperate young sailor who sustained a severe blow over the left side of his chest, and who on the following day fell ill with, and subsequently exhibited all the classic signs and symptoms of, acute pneumonia of the left lung. In this case the coincidence between traumatism and pneumococcal infection was so striking that I ventured the following suggestions, the italics being now inserted:

"In cases of this nature I incline to the assumption that an *involution form* of the specific pneumococcus finding itself, if I may be allowed the expression, in a favourable environment, to wit, damaged lung tissue, *undergoes a rapid evolution into the higher and more virulent variety* associated with acute pneumonia. This latter variety subsequently either *reverts to the lower and more primitive saprophytic type*, should the host die of the disease, or it succumbs to phagocytosis during recovery (of the host)."

In the following number of the JOURNAL Dr. Frederick C. Forster stated that he had, in the previous seven years, treated five precisely similar cases. Apart from the well-known capacity of certain bacteria to undergo evolution and involution, is it not more than probable that the sudden appearance of new diseases in the past may ultimately be proved to be due to a mutation of some harmless saprophytic bacterium into the parasitic type? Seeing that mutations do occur in the plant and animal world, as amply proved by De Vries in the case of the evening primrose, *Oenothera*, and by Morgan in the case of the fly *Drosophila*, we may reasonably expect them to occur in the bacterial world which was the forerunner of both.—I am, etc.,

C. MARSH BEADNELL, R.N.

R.N. Hospital, Chatham, April 11th.

Surgeon Captain R.N.

AN OPERATION PERFORMED UNDER DIFFICULTIES.

SIR,—The difficulties besetting an operator, apart from those of a physical or anatomical nature, are usually determined by the time the emergency arises and the place where it occurs. A sudden emergency demands prompt action, and a remote situation precludes any hope of obtaining help or instruments. Two emergencies placed me in the position of having to determine on prompt action without much prospect of success, and an even stronger prospect of a dire result should no action at all be taken.

The first emergency was the movement of troops to a remote place in the Northern Territories of the Gold Coast, in lat. 11.50 N. and long. 0.40 W. The patient was a native clerk's wife, who had accompanied the troops, and not only were the surgical instruments available few in number, but also they were not applicable to the case in question—an incomplete abortion with severe hæmorrhage. It was impossible to send for instruments from the nearest station where they were available in time to be of any service, and something must be done. The two emergencies—troops recently moved, with a limited surgical equipment, and the wholly unexpected occurrence of a gynaecological case in that situation—were perhaps unique, and certainly embarrassing.

From the first day I set foot on the Gold Coast I made a point of carrying such tools as a country life had taught me to regard as an irreducible minimum to secure the comforts of life at home, and be independent of the assistance of artisans except on great occasions. Many a time these instruments were of signal service in mending a broken hammock or saddle in the bush, or repairing a leaky bath, or the mainspring of a watch, or gramophone, or even in constructing something entirely new from improvised materials when the necessity arose. It was therefore quite natural to think of making a set of instruments for this emergency, the only serious difficulty being the question of raw or improvised material. At this juncture I had recourse to the assistance of my friend Captain Henry, of the West African Frontier Force, who was then in

command of the troops. He was making his evening tour of the lines, and, on being asked what old metal in his armoury he had likely to be of service, he made a minute search, and I regretted to find everything in such perfect order that the only thing he could produce as "unserviceable" was a piece of very hard steel rod about a quarter of an inch in diameter, which had been part of a Maxim-gun extractor. The armourer was not on duty, so I took away the metal almost convinced that the last ray of hope was now extinct.

Outside the door of my mud hut I stumbled on an empty "sparklet" bulb C size, and picking it up, saw in it the outline of a serviceable curette. Everything was plain sailing after that. The sun was approaching the horizon, but I set to work in good spirits, and soon fitted the bulb to the steel rod, making them fast by drilling through the neck of the bulb and the steel rod which was adamant, and riveting the two together with part of a French nail got out of the lid of a packing case. The sun set and the stable lantern was brought in. Its wire handle seemed full of promise, and was easily detached, straightened out, filed down at one end into a fine sharp point, and finally rebent into the shape of a somewhat unorthodox but thoroughly useful tenaculum, to replace the more elegant vulsellum used in such cases. A Sim's speculum was the next desideratum, and a real double-ended one was evolved from what had once been a biscuit tin. It may have been rude, but at all events its angularities were all beaten off and carefully smoothed with emery paper, while rigidity was secured by judicious soldering. A "Primus" stove here proved invaluable in heating the plumber's bolt. The emergency was not so very urgent as to forbid the furnishing of a flexible uterine sound of approved style, so this was made from three strands of copper wire twisted together, soldered for greater security, and graduated in the conventional manner.

Nature now demanded sleep, and daylight was necessary for further search afield to secure wood for the handle of the curette and provide dilators, which were to be made of wood also. A start was made early next morning, and the dilators were made from branches of requisite thickness cut from a hardwood tree. It was thought that these would not swell much or alter in shape during the process of sterilization. This proved correct, and the complete set of double-ended Hegar's dilators was soon ready. The handle of the curette was made of soft wood from a baobab tree, which happens to be one of the few soft woods in that region, and is quite a feature of the landscape, from its immense size and remarkable shape.

The instruments being now all ready and sterilized, an anaesthetist had to be found, "and hastening slowly" to make more sure of success, one had the good fortune to secure the services of Captain Henry, who again came gallantly to the rescue, and proved as good as an expert on that occasion. The only other assistant was one Adamu Wongara, seconded for hospital duties from the Company, whose virtues had blossomed some time previously, first having come to notice when I was put out of action by illness, and on recovering discovered that he had silently imbibed the principles of wound dressing, without any attempt ever having been made seriously to teach him. His previously recognized value, which recommended him for hospital duties, was his capacity as an interpreter, for he could speak seven languages.

The operation was successful, and I had news about a year later that the patient's next pregnancy was happily consummated by the birth of a son, who must now be about ten years old. The original curette and copies of all the other instruments are to be seen in the Wellcome Museum of Medical History in London. I have gratefully to acknowledge the kind permission of the Under Secretary of State for the Colonies to publish this note, and likewise of the Commissioner of Medical Services, Ministry of Pensions, West Midland Region.—I am, etc.

Birmingham, March 21-6.

ALEX. LINDIE.

JOHN EVELYN AND MEDICINE.

SIR.—It is refreshing to notice that some of your readers are able to find time from the cares of panel practice to dip into John Evelyn's *Diary*. There was a reference recently in your pages to the conversation he

had on December 4th, 1661, with the Duke of York, who affirmed of a woman who swallowed a whole ear of barley, which worked out at her side. The diarist, under date March 24th, 1671, mentions another item of medical interest:

"I saw the chirurgion cut off ye leg of a wounded sailor, the stout and gallant man enduring it with incredible patience, without being bound to his chaire as usual on such painfull occasions. I had hardly courage enough to be present. Not being cut off high enough, the gangreen prevailed, and the second operation cost the poore creature his life."

It is to be hoped there are many lovers of Evelyn in the medical profession. His courage and humanity in caring for the wounded and sick sailors committed to his charge are astonishing in that indifferent age.—I am, etc.,

Falkirk, April 11th.

GEORGE C. STEWART.

PROSTATIC SYMPTOMS AND THEIR CAUSES.

SIR.—Being an early sufferer myself, I have read with much interest the correspondence on prostatic symptoms, especially the letter from "Senectus." I have exactly the same symptoms he has described—namely, frequency of micturition, sudden urgency, stream small, hesitancy in starting, and in addition I also get priapism at night, subsiding when the bladder is emptied. "Senectus" states that he is much better since he took certain measures. I, and I am sure others, would be grateful if he would state these measures in detail.

As regards causes, for some time I was wrongly fitted with presbyopic glasses, and my bladder symptoms have improved since correct glasses have been given. Even now I think my bladder symptoms are worse when I have to read and write much in the evening by artificial light. It seems to me as if errors of refraction, not properly corrected, and eye-strain, may be aggravating causes.—I am, etc.

April 11th.

E.F. 53.

THE HARLEQUIN FOETUS.

SIR.—The interesting notes and photographs of this rare condition recently published in the *JOURNAL* remind me that the harlequin foetus has hitherto been one of the riddles of pathology. The following theory may, however, be of service in solving the problem.

The harlequin foetus is atavistic. Its curious collodion-like envelope is due to the persistence of the epithelium, a membrane which, it will be remembered, normally clothes the embryo from the middle of the third to the beginning of the eighth month of intrauterine life. At eight months this layer breaks down and mingles with the sebium to form the vernix caseosa, and in premature children can often be recognized as desquamating, crinkly wisps loosely adherent to the infant's body. Its function is mechanically protective, preventing maceration in the liquor amnii by swaddling the foetus in a confined waterproof sheet. It is generally displaced by the hair and sebium accumulating beneath it, the sebium eventually usurping its waterproof function. Complete persistence of the envelope causes harlequin foetus, partial persistence means ichthyosis.

Now a persistent epithelium is normal to many animals, especially to those whose aquatic habits predispose to maceration of the epidermis—frogs and salamanders, for example. Even among mammals (sloths, certain hogs, probably horses also) it persists till birth, while in cats, bears, sheep, oxen, and deer it is only partially shed. Todd has recorded a fox with dermal scales; Leibreich (Dissert., Halle, 1853) has described a calf with "foetal ichthyosis." So strong, indeed, is this tendency to retain the epithelium that its occasional occurrence in man is only to be expected.

This theory not only explains the covering of the harlequin foetus, but also the irregular cracks and fissures which traverse it, due to torsion and suggesting the irregular cuticular exfoliation periodically occurring in lizards. It explains also the uniformly negative *post mortem* results; this is not surprising, for there has probably never been anything to find, the fault being purely local, involving the skin only. The commoner atavisms are always with us—cleft palate (persistent buccal vault of amphibia), hare lip

(persistent oral cleft of selachian fishes), hypo- and epispadias (persistent reptilian urethra). To these is now added that riddle of dermatology—the harlequin foetus.—I am, etc.,

Manchester, April 13th.

GRAHAM RENSHAW.

BREECH PRESENTATION WITH EXTENDED ARMS.

SIR,—Having read with interest the recent correspondence in the JOURNAL on "Breech presentation with extended legs," it has occurred to me that the following case might be of interest to some of your readers:

At 8 a.m. on April 16th, 1921, I was sent for by a nurse to a case of transverse presentation. The patient, aged 39, was a tall, stout woman, eight and a half months pregnant. She informed me that she had only been pregnant once before, fourteen years ago, when labour was normal in every respect. On examining the abdomen it seemed to me that, although I could not locate the foetal head owing to the large amount of adipose tissue present, the long axis of the child was certainly lying in the axis of the uterus. I was therefore surprised to find on vaginal examination the left hand of the foetus presenting in an os the size of a shilling. There was no doubt about it being a hand. I felt it distinctly grip my index finger, and the nurse had also felt it—hence her diagnosis. The presenting part was so high up that I was unable to identify any other part of the foetus without passing the whole of my hand into the vagina. As the pains were not frequent, I left the patient until 12 noon, when, as only slight progress had been made, I arranged with a colleague to give an anaesthetic at 2.30 p.m., so that I could examine more thoroughly. However, at 1 p.m. the child was born without assistance, the breech being delivered first with both arms extended down the sides of the trunk, the thighs and knees being flexed.

The mother was very big; the pelvis was very roomy and the child was very small, 4½ lb. so I suppose that these three circumstances combined to cause delivery in this uncommon position. I confess that after my vaginal examination I was inclined to agree with the nurse, and thought that delivery would have to be carried out by internal version.—I am, etc.,

H. GOOD, M.B., B.S.Lond.

Brentwood, Essex, April 18th.

Obituary.

HENRY BARNES, O.B.E., LL.D. MCGILL, M.D., F.R.S.E.,
Consulting Physician to the Cumberland Infirmary, and
ex-President of the British Medical Association.

THE death on April 11th, at his house in Carlisle, of Dr. Henry Barnes was briefly announced in our last issue. He was born in 1842 near Wigton in Cumberland, and his life was a long record of distinguished service to his profession and in public life. He graduated with honours at the University of Edinburgh in 1864, and settled in Carlisle in 1866; his first public appointment was that of physician to the Carlisle Dispensary, which he held until, in 1873, he was appointed honorary physician to the Cumberland Infirmary. Other appointments and honours too numerous to mention in detail included the presidency of the British Medical Association in 1896, and at the termination of his year of office he was elected vice-president. Perhaps his almost life-long association with the Cumberland Infirmary as physician, member of and chairman of committee, and finally as its president was the chief element in his fine reputation for energy and single-minded devotion. The writer of these few notes of appreciation, inspired by a long and grateful recognition of Dr. Barnes's services, finds it far from easy to speak in moderate terms of his achievements for this institution. His untiring and unswerving devotion for nearly fifty years to the general and financial advancement of the hospital will live perpetually in the minds of his colleagues, friends, and fellow-townsmen. Dr. Barnes's organizing ability was freely expended in collecting funds for the extension and improvement of the building, and his unfailing charm and kindness of manner, coupled with sound common sense, made him beloved and respected by all with whom he came in contact. Of his work during the war as honorary secretary and treasurer to the Cumberland branch of the British Red Cross Society, which he had been largely instrumental in establishing, it is impossible to speak too gratefully. His unostentatious and quiet manner and unfailing tact at all times marked him as a discerning administrator. It was a matter of pride to his fellow

workers that his services should have been recognized in the bestowal by the King of the O.B.E.

Dr. Barnes's public-spiritedness also found scope in his work as magistrate for Cumberland; he was called to the bench in 1889, and was chairman of the Cumberland Ward Justices from 1904. Dr. Barnes was no mean antiquarian and archaeologist; his antiquarian researches were greatly concerned with the Roman Wall of Hadrian. His presidential address to the British Medical Association, "The medical history of Carlisle," together with numerous other writings on medical and archaeological subjects, contain much of historical interest generally and locally. His contributions to scientific literature comprised papers on Roman medicine and practitioners, Roman medical inscriptions in Britain.

Dr. Barnes's retirement from practice by no means curtailed his efforts for the public good; he was of too earnest and sympathetic a heart for his grasp of affairs to slacken, and the time thus gained he unsparingly devoted to the various institutions of whose administrative bodies he was member. In Carlisle, where his life's work was done, and throughout Cumberland his name will ever be pronounced with respect and affection, and his personality sympathetically remembered and honoured as one whose gifts have truly served his country.

His interest in the British Medical Association was lifelong, and he was a member of its central council from 1868 to 1900. He was a Fellow of the Royal Society of Edinburgh, and received the honorary degree of LL.D. from the McGill University when he visited Montreal as retiring President in 1897.

Dr. Barnes married in 1873 Miss Emily Mary Barnes, and is survived by his wife and a son and daughter.

The funeral took place on April 15th; the mourners, in addition to members of the family, included many members of the medical profession in Carlisle, Cumberland, and the Border counties. Dr. Livingstone of Dumfries represented the British Medical Association and the Border Counties Branch. The city officials also attended, and the Mayor, speaking for the Bench afterwards, said that during the thirty-four years Dr. Barnes was a magistrate he had been a constant attender at the court, and his judgement and advice were highly valued. A tribute to his memory was paid also by Mr. John Graham on behalf of the solicitors practising in the courts.

SURGEON-LIEUT.-COLONEL L. MANCHÉ, M.D.,

Malta.

SURGEON-LIEUT.-COLONEL L. MANCHÉ, M.D., late of the Royal Malta Artillery, died at Valletta, Malta, on February 16th, at the age of 75 years. The late Colonel Manché had been the founder of the Malta and Mediterranean Branch of the British Medical Association, and acted as Honorary Secretary from its formation in 1888 to 1902. He was several times President of the Branch, and at the time of his death he was Vice-President both of the Malta Branch of the Association and of the Malta Medical Association. Up till the end of his life he maintained the keen interest he had always shown in the organization of the local medical body, and in bringing together the naval, military, and civil members of the profession on the island, amongst all of whom he was deservedly popular.

Colonel Manché was the first holder of the Chair of Ophthalmology in the Malta University, and he performed pioneer work in developing the teaching and the practice of the speciality. He established and maintained at his own expense an ophthalmic clinic for poor patients. His great professional ability, his unselfish interest in all matters that affected the welfare of the medical profession and of the general public, and his courteous and charitable disposition were greatly appreciated by all sections of the community, and his death has caused the most widespread regret.

THE LATE DR. PETER DUNCAN OF CROYDON.

Sir Thomas Barlow, Bt., writes: Peter Duncan was a first-rate student, alert, accurate and thorough in both theory and practice. The same qualities characterized his career as a singularly well-informed and thoroughly equipped practitioner. It was the rarest thing in a consultation for Duncan to have missed anything, and if he had pride in his professional work it was that he took cognizance of the whole man. He never spared himself in

his solicitude for the welfare of his patients, and they knew and appreciated it. Duncan was a loyal colleague and a staunch friend. He never "wore his heart on his sleeve," and, indeed, he had a certain reserve; but now and again his friends were struck by the evidences in quiet ways of his keen and abiding remembrance and of his warm regard. Requiescat in pace!

Dr. Percy J. Duncan writes: In your appreciative memoir of the late Dr. Peter Thomas Duncan you have written that he was a cousin of the late Dr. Matthews Duncan. May I correct that statement and add that the family was an Irish one dwelling in the neighbourhood of Kilkenny. Three sons became members of the medical profession in London—Dr. William Duncan, Dr. Peter Charles Duncan, and Dr. B. Archdekin Duncan—and the subject of your memoir and his younger brother, Dr. William Duncan, were the sons of the first named. There is a cousin still in Ireland, the Rev. Peter Charles Duncan of Kildonagh, the son of the eldest brother of the family. The writer is the second son of the Dr. Peter Charles Duncan referred to above.

Dr. THOMAS LETTIS of Great Yarmouth died on April 9th as the result of injuries sustained three days before, when he was knocked down by a motor car while endeavouring to board a tramcar. Dr. Lettis, who was a member of an old Yarmouth family, was born in 1845. He received his medical education at University College Hospital, and took the diplomas of M.R.C.S. in 1866 and L.S.A. in 1877, graduating M.D. Durh. in 1899. After holding the post of assistant house-surgeon at University College Hospital he returned to his native town to practise. At the time of his death he was consulting honorary medical officer to the Great Yarmouth Hospital and a member of the Great Yarmouth Division of the British Medical Association.

Dr. ARTHUR DENNISON died at Burley, Leeds, on April 6th, aged 52. He was educated at Edinburgh, where, after taking the Scottish triple qualification in 1891, he graduated M.B. and Ch.B. in 1893, and M.D. in 1895. He then went into practice at Burley, Leeds, where he was medical officer and public vaccinator to No. 4 district of the Leeds Union. He took a temporary commission as lieutenant in the R.A.M.C. on October 15th, 1915, and was promoted to captain after a year's service. He saw service in Malta and Salonica as sanitary section staff captain; at the former place illness necessitated his admission to a tuberculosis sanatorium, from whence he only returned to England last Christmas. He took great interest in local affairs, and was the representative of the West Ward on the Leeds City Council for nine years, prior to which he also represented the Headingley Ward on the same body. He was also a former chairman of the corporation sanitary committee. The funeral, which took place on April 9th, was attended by many friends, including members of the health staffs of the Leeds corporation.

The Services.

INDIAN MEDICAL SERVICE. CIVIL EMPLOYMENT PAY.

The following communiqué has been received from the India Office. It is not dated, but was sent to us on April 18th:

1. With effect from January 1st, 1920, the new scales of pay for officers of the Indian Medical Service in civil employment are as follows:

(a) The rates of pay for officers of the Indian Medical Service in civil employment, who hold one of the following appointments, are as specified below:

- Director-General, Indian Medical Service, Rs. 3,500.
- Surgeon-General, Rs. 3,000.
- Inspectors-General of Civil Hospitals, Rs. 2,750.
- Sanitary Commissioner with the Government of India, Rs. 2,500, rising by annual increments of Rs. 100 to Rs. 3,000.
- Inspectors-General of Prisons, Rs. 2,300, rising by annual increments of Rs. 50 to Rs. 2,500.
- Sanitary Commissioners, Bengal, Bihar, and Orissa, United Provinces, Punjab, Madras, Burma, Bombay, and Central Provinces, Rs. 2,100, rising by annual increments of Rs. 60 to Rs. 2,400.
- Sanitary Commissioner, Assam, Rs. 1,950, rising by annual increments of Rs. 50 to Rs. 2,300.
- Principal, Medical College, Calcutta, Rs. 2,350.
- Superintendent, Campbell Medical School, Calcutta, Rs. 2,350 for a Lieutenant Colonel and Rs. 1,950 for a Major.
- Senior Medical Officer, Port Blair, Rs. 1,950.
- Surgeon Superintendent, Presidency General Hospital, Calcutta, Rs. 2,350.
- Surgeon Superintendent, St. George's Hospital, Bombay, Rs. 2,350.
- Superintendent, General Hospital, Rangoon, Rs. 2,150.

(b) The rates of pay of officers of the Indian Medical Service in civil employment, who do not hold any of the appointments specified in the other clauses of this paragraph, are shown in the following statement:

(1)	(2)	(3)	(4)	(5)
Rank and Service.		Pay (Rs. per Month).	Overseas Pay (Rs. per Month).	Total Pay (Rs. per Month).
Lieutenant	...	500	150	650
Captain:				
(i)	During the first 3 years' service as Captain	650	150	800
(ii)	With more than 3 and less than 6 years' service as Captain	720	200	920
(iii)	With more than 6 years' service as Captain	850	200	1,050
Major:				
(i)	During the first 3 years' service as Major	950	250	1,200
(ii)	With more than 3 and less than 6 years' service as Major	1,100	250	1,350
(iii)	With more than 6 years' service as Major	1,250	250	1,500
Lieutenant Colonel:				
(i)	Until completion of 23 years' total service	1,500	250	1,750
(ii)	During the 24th and 25th years of service	1,600	250	1,850
(iii)	After completion of 25 years' total service	1,700	250	1,950
(iv)	When selected for increased pay	1,850	250	2,100

(c) The rates of pay in columns (3) and (5) of the statement in clause (b) are increased by Rs. 250 a month for all officers of the Indian Medical Service who hold one of the following appointments:

- (i) Professorial appointments, Bengal, Punjab, United Provinces, Madras, and Bombay;
- (ii) Principal, Lahore Medical College;
- (iii) Principal, Lucknow Medical College;
- (iv) Surgeon to Gokuldas Tejpal Hospital, Bombay;
- (v) Imperial Serologist;
- (vi) appointments in the Bacteriological Department;
- (vii) Chemical Examiners;
- (viii) Deputy Sanitary Commissioners;
- (ix) Port Health Officers at Bombay, Calcutta, Rangoon, and Aden;
- (x) Health Officers, Simla, Imperial Delhi, and Delhi Municipality;
- (xi) Plague Medical Officers;
- (xii) Deputy Director-General, Indian Medical Service;
- (xiii) Assistant Directors-General, Indian Medical Service (Sanitary) and (Stores);
- (xiv) Surgeon to His Excellency the Viceroy;
- (xv) Police Surgeon, Rangoon;
- (xvi) Superintendent, Central Lunatic Asylum;
- (xvii) Superintendent, Army Institute;
- (xviii) Superintendent, Royal Botanical Gardens, Calcutta.

(d) The rates of pay in columns (3) and (5) of the statement in clause (b) are increased by Rs. 200 a month for all officers of the Indian Medical Service who hold one of the following appointments:

- (i) First and second Resident Surgeons, Presidency General Hospital, Calcutta;
- (ii) Resident Surgeon, St. George's Hospital, Bombay;
- (iii) Surgeons to Their Excellencies the Governors of Bombay, Madras, and Bengal.

(e) For Superintendents of 1st class Central Gaols and the second Medical Officer, Port Blair, the rates of pay in columns (3) and (5) of the statement in clause (b) are increased by Rs. 150 a month.

(f) For Personal Assistants to Surgeons-General the rates of pay in columns (3) and (5) of the statement in clause (b) are increased by Rs. 100 a month.

(g) For Superintendents, 2nd class Central Gaols, the rates of pay in columns (3) and (5) of the statement in clause (b) are increased by Rs. 50 a month.

(h) In addition to the above rates of pay, officers of the Indian Medical Service who hold one of the following appointments draw in addition the duty allowances mentioned:

- (i) Officers of the Bacteriological Department who are Directors of 1st class Central and Provincial Laboratories, Rs. 250 a month;
- (ii) Officers of the Bacteriological Department, who are Directors of Pasteur Institutes, Rs. 100 a month;
- (iii) Deputy Director-General, Indian Medical Service, Rs. 400 a month, subject to a maximum of Rs. 2,500 a month for the total pay and duty allowance combined;
- (iv) Assistant Directors-General, Indian Medical Service (Sanitary) and (Stores), Rs. 250 a month, subject to a maximum of Rs. 2,500 a month for the total pay and duty allowance combined.

Note. The appointment of Additional Assistant Director-General, Indian Medical Service, will, for the present, continue to grade for the purposes of pay as a Deputy Assistant Director, Medical Services, Army Headquarters.

2. The rates of overseas pay specified in paragraph 1, clause (b), apply only to the officers of the Indian Medical Service in civil employment who fall under paragraph 1, clauses (a) to (h). This overseas pay will be drawn by all such officers who were in permanent service on the 1st December, 1918, and by all such British officers who have joined or may join the service after that date. Such Indian officers who have joined or may join the permanent service after the 1st December, 1918, will not be allowed to draw this overseas pay, unless they are already drawing pay at a higher rate than is admissible without overseas pay, in which case they will continue to enjoy the benefit of that high rate for so long as they would otherwise have done; but they will not receive any further increment until it is due to them under the scales now sanctioned.

3. Exchange compensation allowance is withdrawn with effect from the 1st January, 1920.

4. In bringing officers at present in service on to the revised rates of pay, Articles 156 to 158 of the Civil Service Regulations

will not apply. A personal allowance is, however, sanctioned for all existing incumbents of offices who are drawing a salary greater than that admissible under the scales now sanctioned, so as to bring their emoluments up to the amount now enjoyed. These personal allowances will be absorbed as increments are earned.

5. Subject to the provision in paragraph 4 the initial pay of the scales now sanctioned in the case of an officer who holds an appointment on a time-scale of pay specified in paragraph 1, clause (a), will be regulated according to the number of years he has held the appointment permanently, and the broken period of a year of service, which such an officer has put in before January 1st, 1920, will remain at his credit for the next increment.

Note.—The rates of pay in paragraph 1, clause (b), apply to all appointments held by officers of the Indian Medical Service in civil employ, which are not specified in the remaining clauses of that paragraph. These include, amongst others, the following appointments:—Civil Surgeons; Agency Surgeons; Presidency Surgeons, 1st and 2nd Districts, Bombay; Police Surgeon, Calcutta; Senior Surgeon and *ex officio* Sanitary Commissioner, Mysore Darbar; Medical Officer, Kathiawar, Political Agency; Ophthalmic Surgeon, General Hospital, Rangoon; Medical Officer, Seistan; Director, Medical Department, Bikanir; Medical Officer, Mewar Bhil Corps, Kherwara; Superintendent of Mahabeshwar; Superintendent of Matheran; Resident Surgeon, Medical College, Calcutta; Resident Physician, Medical College, Calcutta; Resident Surgeon, Eden Hospital, Calcutta; Resident Medical Officer, General Hospital, Madras; and Assistant Superintendent, Government Maternity Hospital, Madras.

ROYAL AIR FORCE NURSING SERVICE.

REGULATIONS regarding conditions of service in the Royal Air Force Nursing Service, which was established by Royal Warrant on January 27th, 1921, have now been issued by the Air Ministry. The service consists of a matron-in-chief, matrons, senior sisters, sisters, and staff nurses. Candidates are required to join as staff nurses, and appointments, which are subject to a probationary period of six months, are given to approved persons of British parentage, over 25 and under 35 years of age, who possess a certificate of training for at least three years at a large civil hospital in the United Kingdom. Full particulars of the service and forms of application for appointment may be obtained from the Matron-in-Chief, Air Ministry, Kingsway, London, W.C. 2.

DEATHS IN THE SERVICES.

Deputy Surgeon-General Oliver Codrington, R.A.M.C. (ret.), who died recently at the age of 82, was educated at the London Hospital, and took the M.R.C.S. in 1853, the L.S.A. in 1859, and the M.D. of St. Andrews twenty years later, in 1878. Entering the army as assistant surgeon on June 13th, 1859, he became brigade surgeon on August 19th, 1885, and retired, with a step of honorary rank, on March 27th, 1886. He served in the New Zealand war of 1864-66, receiving the medal.

Major John FitzGerald Burke, R.A.M.C. (ret.), died recently at Pembroke. He was born at New Quay, County Clare, on June 14th, 1857, took the L.R.C.P. and S.E.D. in 1882, and entered the army as surgeon on August 1st, 1885, attaining the rank of major after twelve years' service, and retired on October 29th, 1902. After his retirement he was employed at Lancaster from 1902 to 1911, and subsequently at Penally; and also during the recent war. He had a long list of war service. He served as a civil surgeon in the Egyptian war of 1882, before entering the army, receiving the medal with the Khedive's bronze star; Burmah, 1885-87, medal with clasp; Ashanti, 1895-96, star; West Africa, Lagos, 1897-98, Sierra Leone, 1898-99; Protectorate Expedition, medal with clasp; and South Africa, 1900, Queen's medal with clasp.

Major William Barbour A. K. Cullen, I.M.S., died of pneumonia at Meerut on March 29th. He was the younger son of the late Deputy Surgeon-General Cullen, A.M.S., born on March 11th, 1881, and was educated at Edinburgh, where he graduated M.B. and Ch.B. in 1903. After filling the posts of assistant house-surgeon at the Chesterfield Hospital and at the County Hospital, Taunton, he entered the I.M.S. as lieutenant on February 1st, 1906, attaining the rank of major on August 1st, 1917. He had a varied experience of the different theatres of war in the past seven years, accompanied the original Indian force to Europe in November, 1914, and served in France and Belgium till November, 1915; in Mesopotamia from December, 1915, to March, 1916; in the Mahsud operations on the North-West frontier of India from May to August, 1917; with the Egyptian expeditionary force in June and July, 1918; and with the Aden field force from July to October, 1918; and was mentioned in dispatches in the *London Gazette* of June 15th, 1916.

Captain Robert Scott Cumming, R.A.M.C., S.R., died in the 3rd British General Hospital at Basra on March 14th. He was the eldest son of the late Robert Cumming, advocate, of Aberdeen, and was educated at the university in that city, where he graduated M.B. and Ch.B. in 1915. Immediately afterwards he took a commission as lieutenant in the Special Reserve of the R.A.M.C. on July 24th, 1915, and was promoted to captain after six months' service. He received the Military Cross on July 26th, 1917.

The King of the Belgians has conferred the decoration of Officer of the Order of the Crown of Belgium upon Wing-Commander Lewis Leister Greig, M.V.O., M.B., R.A.F., in recognition of valuable services rendered in connexion with the war.

Universities and Colleges.

ROYAL COLLEGE OF SURGEONS OF ENGLAND.

A QUARTERLY council was held on April 14th, when Sir Anthony Bowlby, President, was in the chair.

The following prizes were awarded: *Jacksonian Prize*: to Mr. Harold Burrows (Southsea) for his essay on the results and treatment of gunshot injuries of the blood vessels. *John Tomes Prize*: to Dr. James Sim Wallace for his work in connexion with the prevention of dental caries. *Cartwright Medal and Prize*: to Mr. W. Kelsey Fry, M.C. (Guy's Hospital), for his essay on the treatment of injuries of the jaws, and the restoration by mechanical means of parts of the jaws lost as the result of injury or removal on account of disease.

The subject selected for the Jacksonian prize for the year 1921 is the effects produced by radium upon living tissues, with special reference to its use in the treatment of malignant disease.

The subject for the next Cartwright prize for 1921-25 is: Variations in the form of the jaws, with special reference to their etiology and their relation to the occlusion of the dental arches.

Mr. Kenneth Owen Parsons was appointed Bigley student for the ensuing three years.

Professor Charles Scott Sherrington, P.R.S., and Sir S. Squire Sprigge, members of twenty years' standing, were elected to the Fellowship.

Mr. Raymond Johnson was elected to represent the College in the University of London.

CONJOINT BOARD IN SCOTLAND.

THE following candidates have been approved at the examination indicated:

FINAL EXAMINATION.—*Medicine*: A. Shakur, J. L. Lloyd-Jones, V. H. L. Anthonisz, W. B. Stott, W. Campbell, R. N. Nanda, A. Y. Khan. *Surgery*: J. S. A. Rogers, O. P. Fox, W. B. Stott, R. N. Nanda. *Midwifery*: A. Shakur, J. L. Lloyd-Jones, J. R. Williams, O. P. Fox, J. Pedris, E. P. Dewar, A. Y. Khan. *Medical Jurisprudence*: Enid A. Williams, T. T. Hoskins, G. H. Dobbin, M. S. Hassen, P. G. Bainbridge, D. R. Nicol, J. L. Lloyd-Jones, Rachel Caplan.

The following, having passed the Final Examination, were admitted L.R.C.P.E., L.R.C.S.E., L.F.P.S.Glas.:

Helen Worthington, D. R. Cilliers, N. M. D. Fox, D. J. H. Ferdinando, J. Murray, A. J. Vakil, A. A. Hamilton, A. H. Taylor, R. E. Hopton, J. L. Banhavy, D. N. Gore, P. Parthasarathy, M. Morrison, L. M. Sen, E. K. Ray, J. C. Rowan, H. Smith, Miss A. Shaw, D. S. Scott, R. A. W. Procter, Miss A. M. Mackay, J. C. Coetzee, K. A. Gandhi, C. L. Bahni, N. S. Ketwall, F. X. Costello, K. C. Chong, S. Miller, Surgeon Lieut. Commander P. N. Button, Miss M. Jervis, A. R. McLean, Miss L. J. Murphy, A. R. Jennings, Miss M. J. Ahern.

With distinction.

LONDON SCHOOL OF TROPICAL MEDICINE.

THE following candidates have passed the examination of the school at the termination of the sixty-fifth session, January-April, 1921:

C. T. Maitland (Duncan Medal), H. R. S. Richards, A. Crawford, Miss M. M. Ross, R. G. Simpson, J. O. Beven, W. M. Howells, J. M. Wallace, J. Segal, O. M. Banhavy, D. N. Gore, P. Parthasarathy, M. Morrison, L. M. Sen, E. K. Ray, J. C. Rowan, H. Smith, Miss A. Shaw, D. S. Scott, R. A. W. Procter, Miss A. M. Mackay, J. C. Coetzee, K. A. Gandhi, C. L. Bahni, N. S. Ketwall, F. X. Costello, K. C. Chong, S. Miller, Surgeon Lieut. Commander P. N. Button, Miss M. Jervis, A. R. McLean, Miss L. J. Murphy, A. R. Jennings, Miss M. J. Ahern.

Medical News.

THE King has been pleased, on the recommendation of the Home Secretary, to appoint Dr. Sidney Reginald Dyer, Medical Inspector of Prisons, to be a Commissioner of Prisons. Dr. Dyer was formerly medical officer of H.M. Prisons, Stafford, Wandsworth, and Buxton, and was called to the Bar at the Middle Temple in 1896.

THE Prince of Wales (President of the hospital) will take the chair at the annual meeting of the Court of Governors of the Hospital for Sick Children, Great Ormond Street, on Tuesday, May 3rd, at 4 p.m.

THE Minister of Pensions has appointed Dr. A. E. Knight, Commissioner of Medical Services, to hold the combined post of Regional Director and Commissioner of Medical Services in the Ulster Region of the Ministry.

A PARLIAMENTARY White Paper issued recently states that the total receipts paid into the motor taxation account by the local authorities down to March 7th was a little over seven million sterling. The number of cars taxed on horse-power, which would include all ordinary private and professional cars, was 202,000, and the yield was £2,810,800. Commercial cars and lorries yielded half a million less. Motor cycles numbered 186,000, and yielded £488,600. There were two hundred mechanically driven bath chairs, yielding £50 in taxes. It appears that nearly all the licences taken out are for the whole year. The reply to a question in the House of Commons shows that by the end of March the total receipts had increased to seven million and three-quarters.

A SPECIAL meeting of the Fellows of the Royal Society of Medicine will be held on Monday next, at 5 p.m., to consider a recommendation of the Council that the subscription of all Fellows in the London postal area should be raised to five guineas and that for Fellows residing elsewhere in the United Kingdom to four guineas. In addition it has been arranged to reduce the cost of the *Proceedings* by using cheaper paper and smaller type. It is proposed that the subscription paid by Fellows living abroad shall remain three guineas.

MR. ARTHUR CHEATLE will give a lantern demonstration on "The cellular development in the temporal bone" at the opening of the summer session of the Central London Throat and Ear Hospital, Gray's Inn Road, on Wednesday, May 4th, at 4 p.m.

THE fifth annual celebration of National Baby Week will be held from July 1st to 7th, 1921. The chairman of the executive committee is Dr. Eric Pritchard; the honorary secretaries are Mrs. H. B. Irving and Mrs. Sloan Chesser, M.D., and the secretary Miss M. S. Gray. The office is at 5, Tavistock Square, W.C.1.

As the Industrial Welfare Society receives continual requests from firms for definite aid in the application of the principle of industrial welfare to their particular needs, the society has organized itself for this purpose. In addition to the headquarters staff in London and the local branches under the direction of district organizers, a working arrangement in regard to special subjects bearing upon industrial welfare has been made with the appropriate societies and experts both in this country and abroad. The headquarters staff is available for the discussion of conditions and the suggestion of schemes of industrial welfare for different industries, and it sends speakers to address gatherings on subjects kindred to its object. It will assume complete responsibility for the carrying out of welfare schemes, or it will recommend qualified directors. The society also advises on general health problems affecting various industries, and on the establishment of holiday and convalescent centres in industrial districts. There is little doubt that this propaganda work is best carried on by a voluntary society rather than it should be cramped by the rules and regulations within which a Government department would have to work. The offices of the Industrial Welfare Society are at 51, Palace Street, London, S.W.

AN English-speaking conference on infant welfare will be held, under the auspices of the National Association for the Prevention of Infant Mortality and National Baby Week Council, at the Kingsway Hall, London, on July 5th, 6th, and 7th, with Viscount Astor as president. The chief subjects under discussion will be: residential provision for mothers and babies; inheritance and environment as factors in racial health; and the supply of milk, its physiological and economic aspects.

THE annual meeting of the Medical Mission Auxiliary of the Church Missionary Society will be held in the Queen's Hall, Langham Place, London, W.1, on Wednesday, May 4th, when the chair will be taken by Colonel A. Carless, C.B.E., M.S., at 7 p.m.

THE National League for Health, Maternity, and Child Welfare has just issued its report for the year 1920. This League is a federation of ten different societies which deal with various aspects of the questions included in the title. From the report it is evident that a great deal of work is being carried out in every part of the country by the different sections of the League, and by the co-operation of these sections overlapping of the activities is prevented. During the past year five maternity hostels and twenty-six ante-natal clinics have been established by the aid of the League, and under its auspices are carried on a babies' hotel and nursery training school at Stoke Newington, a convalescent home for mothers and babies at Shooters Hill, and a holiday home, formerly at Henley and now to be re-established at Maidenhead.

AT the meeting of the Société française d'oto-rhino-laryngologie in Paris, on May 9th, Drs. Moore and Hautant will read a paper on the radiotherapy of malignant tumours in oto-rhino-laryngology, and Dr. Lemaître will discuss the orbito-ocular complication of sinusitis.

A MEETING of the Society of German Laryngologists and of the German Otological Society will be held at Nuremberg on May 12th to 14th, under the presidency of Dr. Boenninghaus and Dr. Rudolf Panse of Dresden, when the organization of a school otological service will be discussed.

THE Vienna Medical Society has elected Dr. Ferrière of Geneva and Mr. Hoover of Washington honorary members in recognition of their services to Austria.

DR. EDWARD WALFORD, who has resigned the post of medical officer of health for the city of Cardiff, has been granted by the city council a pension of £500 per annum. Dr. Walford has been M.O.H. of Cardiff since 1888, and as his predecessor, Dr. Paine, held office from 1847 until his appointment, Cardiff must be one of the very few cities in this country if not the only one—in which only two medical officers of health have held office.

The Conjoint Board of Scientific Societies has decided to discontinue the publication of the Annual Calendar and Fortnightly Bulletin of Scientific Meetings (Diary of Scientific and Technical Societies) owing to the heavy printing liabilities incurred.

THE mortality of illegitimate infants in 1919 in England and Wales was a little over twice as great as of the legitimate. It was particularly heavy from gastro-intestinal disorders. The Affiliation Orders Act of 1914 permitted the appointment of a collecting officer, whose duty it is to see that the mother of an illegitimate child receives an adequate sum for its maintenance from the father. The Bastardy Bill, which it is hoped may be reached in the House of Commons on Friday next, April 29th, would make the clerk to the justices (or the chief clerk of a metropolitan police court) the collecting officer, but would permit him to delegate his powers. The bill would raise the maximum contribution from the putative father from 10s. weekly to 40s.; it would also legitimize a child born out of wedlock if the parents subsequently intermarried. The bill as originally drafted was a very much more ambitious measure: as it now stands, and regarding it only from the public health point of view, we consider that it deserves support. Its most important point is the power it would give to the magistrates to increase the weekly allowance. The high mortality among illegitimate infants is probably in the main due to the fact that the mother must put it out to nurse either altogether or during the day in order to earn a living.

Letters, Notes, and Answers.

As, owing to printing difficulties, the JOURNAL must be sent to press earlier than hitherto, it is essential that communications intended for the current issue should be received by the first post on Tuesday, and lengthy documents on Monday.

ORIGINAL ARTICLES and LETTERS forwarded for publication are understood to be offered to the BRITISH MEDICAL JOURNAL alone unless the contrary be stated.

CORRESPONDENTS who wish notice to be taken of their communications should authenticate them with their names—of course not necessarily for publication.

AUTHORS desiring reprints of their articles published in the BRITISH MEDICAL JOURNAL are requested to communicate with the Office, 429, Strand, W.C.2, on receipt of proof.

In order to avoid delay, it is particularly requested that ALL letters on the editorial business of the JOURNAL be addressed to the Editor at the Office of the JOURNAL.

THE postal address of the BRITISH MEDICAL ASSOCIATION and BRITISH MEDICAL JOURNAL is 429, Strand, London, W.C.2. The telegraphic addresses are:

1. EDITOR of the BRITISH MEDICAL JOURNAL, *Antilog*, Westrand, London; telephone, 2630, Gerrard.

2. FINANCIAL SECRETARY AND BUSINESS MANAGER (Advertisements, etc.), *Articulate*, Westrand, London; telephone, 2630, Gerrard.

3. MEDICAL SECRETARY, *Medisecret*, Westrand, London; telephone, 2630, Gerrard. The address of the Irish Office of the British Medical Association is 16, South Frederick Street, Dublin (telegrams: *Bacillus, Dublin*); telephone 4737, Dublin, and of the Scottish Office, 6, Rutland Square, Edinburgh (telegrams: *Associate, Edinburgh*); telephone, 4351, Central.

QUERIES AND ANSWERS.

WE are asked what steps a V.A.D. nurse, who wishes to train as an assistant in a pathological laboratory, should take.

"MEDICUS" writes: An old patient, who wears an artificial eye, asks how the discoloration and dulling from use can be removed? Would any acid or other chemical effect this without damaging the glass? The makers charge a guinea or more to repolish an artificial eye.

The repolishing and colouring of an artificial eye is not a piece of work that can be safely undertaken by an amateur. It needs much skill and long practice, with a full knowledge of the complicated art of glass enamelling. The cost of the work indicated in the inquiry is high, and estimates should be sought from some of the larger firms that specialize in this work—for example, Messrs. Halford, 41, Upper Tollington Place, London, N.4; Messrs. Taylor and Miller, 8, New Oxford Street, London, W.1, or Messrs. Maw, Son and Sons, Aldersgate Street, London, E.C.

INCOME TAX.

"SIMPLICITAS" asks what is the method of dealing with partnership profits.

The average profits of the practice are ascertained that is, the gross receipts (or bookings less allowance for bad debts) less the expenses incurred in the working of the practice for the past three years. This "average" sum is assessed on the firm, but the appropriate allowances for the individual partners are deductible therefrom. The tax is payable by the firm in law, but in fact it is usually shared between the partners on the basis of their individual shares, the inspector of taxes supplying the necessary figures on request. Income tax is payable in two instalments—that is, on January 1st and July 1st, in respect of the income for the year ending April 5th, whether that income has been received in cash or not.

"MEDICO" has been carrying on a general practice, and, to a more limited extent, a specialist's practice elsewhere. He has sold his general practice, and proposes to reside near, and devote his whole time to, his specialist's practice. How will he then be assessable?

On the basis of his past three years' receipts from, and expenses in connexion with, the specialist's practice only. The expense of removal will not be an admissible deduction.

"F. R. I. P. H." asks for advice as to the following car purchases and sales: (1) Car A, 12 16 h.p., second hand, bought August, 1919, for £525 and sold for £415; (2) car B, small second-hand car, bought February, 1920, for £220, and still retained; (3) car C, bought August, 1920, 10.5 h.p., new, for £550.

The difficulty is that the cars are so dissimilar. Assuming that car A (in the condition in which it was bought) would have cost £525 in August, 1920, the amount of deductible expense is £525 less £415=£110. The purchase of an additional car does not give rise to a claim for expenses, but if cars B and C were sold and a car superior to either were bought our correspondent could then claim that the whole of the net cost could be allowed that is, the two smaller cars could be reckoned as equivalent to a single new car of higher power or quality.

"A. B. C." inquires whether income tax is payable on "temporary half-pay granted on account of a disability caused by the war."

Prima facie a "disability pension" is exempt and "half-pay" is chargeable. We should like to be clearer on the facts before giving a categorical reply. Can the Government grant temporary half-pay "on account of a disability"? We suggest that "A. B. C." might ascertain the precise sub-head of the War Office Vote to which the payment is charged. It may, of course, be a disability pension measured in terms of half-pay.

"EXPECTANS" inquires as to the method of dealing with 4 per cent. tax compounded interest on the Government 1929-42 Stock.

It should not be returned "for assessment," but should be included in any declaration of total income being shown separately and marked "tax compounded." On the figures given by "Expectans," and assuming that he is a married man, the tax payable by him would be as follows:

	£	s.	d.
Earned income, less 10 per cent. ...	810	0	0
5 per cent. War Loan interest ...	150	0	0
Assessable income ...	960	0	0
Deduct personal allowance ...	225	0	0
Taxable income ...	735	0	0
Tax payable—£225 at 3s. ...	33	15	0
£510 at 6s. ...	153	0	0
	186	15	0

The income on the 4 per cent. stock is not "taxable," as the tax is compounded.

LETTERS, NOTES, ETC.

THE medical officer of health for the Port of London, Dr. W. M. Willoughby, reports that since the campaign was instituted twenty years ago 1,169,692 rats have been destroyed in the docks and on vessels arriving in the port.

EFFECT OF GUNSHOT WOUND ON SKULL.

"CORNER" writes: The following case may be of interest to your readers, showing the necessity in all cases of a gunshot wound for a *post mortem* examination to prove accurately the entrance, and exit of the bullet, and also the effect of cordite powder in not producing scorching or burning at the entrance. A young officer was shot dead in a barrack room, one other

officer being in the room with him. There was on the side of the skull, just behind the left ear, a very small wound which the two surgeons who examined the body in the first instance diagnosed as the entrance wound. In a parallel line across the skull there was a wound behind the right ear, showing bleeding and laceration, and an aperture considerably larger than on the left side. This was diagnosed as the exit wound. If the first diagnosis had been correct, the automatic revolver which had been used must have been held in a straight line behind the left ear—an almost impossible position for a right-handed man. The skull was opened and the bone of the skull very carefully examined; both surgeons were convinced that the first diagnosis was wrong. The evidence from the splintering of the bone, and the way such splinters had been carried into the skull, showed that it was the large wound on the right side which was the entrance wound, and the very small wound on the left side the exit. The next point was that there was no apparent singeing, although the evidence was that the deceased held the revolver close to his head. The revolver was an automatic, carrying a 0.22 cartridge, and the powder was alleged to be cordite. A sheep's head was obtained, and a rabbit's skin tightly stretched over this head. Several shots were fired from the revolver into the head, and it was proved that, firing the revolver two inches from the head, there was no discoloration or scorching of the hair on the rabbit's skin, and the fracture of the bones of the sheep's head, where the bullet passed through, corresponded to that of the bones of the skull of the deceased—namely, a considerable wound, and fracture where the bullet entered, and a very small wound hole where the bullet came out.

The generally accepted theory appears to be that the exit wound is always larger than the entrance. This theory is evidently unreliable, and had it been accepted in the case herein referred to, the other officer in the room would have been charged with murder.

TERMINOLOGICAL CONFUSION.

THE REV. J. O. H. CARTER, M.A. (Slymbridge Rectory, Glos.), writes to suggest that in discussions with regard to venereal disease confusion would be avoided by using "prophylactic" for prevention of disease *ante factum*, that is, before the sexual act, and "metaphylactic" for prevention of disease *post factum*—after the act.

BRITISH OPHTHALMIC HOSPITAL, JERUSALEM.

THE British Ophthalmic Hospital in Jerusalem is a hard-working charitable institution which is carried on by the Order of the Hospital of St. John of Jerusalem in England, Lieut.-Colonel J. C. Strathearn being the chief surgeon. Since the war a considerable amount of restoration has had to be done, and extension of the out-patient department is still necessary. The report for 1920 shows, however, that the work of the hospital is now rapidly approaching—and, in some items, such as the number of operations performed, actually surpassing the average of the years immediately before the war.

A CORRECTION.

DR. J. A. HAMFIELD (London) writes: May I correct an error that has crept into print in the advertisement of the lectureship in psychotherapy at Birmingham University? I am there wrongly described as lecturer in psychotherapy at King's College, whereas my position is the more humble one of lecturer in psychology. The error has naturally given rise to some misapprehension.

VACANCIES.

NOTIFICATIONS of offices vacant in universities, medical colleges, and of vacant resident and other appointments at hospitals, will be found at pages 29, 32, 33, 34, 35, and 36 of our advertisement columns, and advertisements as to partnerships, assistantships, and locum tenencies at pages 30, 31, and 32.

THE appointment of certifying factory surgeon at Lynham (Oxford) is vacant.

SCALE OF CHARGES FOR ADVERTISEMENTS IN THE
BRITISH MEDICAL JOURNAL.

	£	s.	d.
Six lines and under ...	0	9	0
Each additional line ...	0	1	6
Whole single column (three columns to page) ...	7	10	0
Half single column ...	3	15	0
Half page ...	10	0	0
Whole page ...	20	0	0

An average line contains six words.

All remittances by Post Office Orders must be made payable to the British Medical Association at the General Post Office, London. No responsibility will be accepted for any such remittance not so safeguarded.

Advertisements should be delivered, addressed to the Manager, 429, Strand, London, not later than the first post on Tuesday morning preceding publication, and, if not paid for at the time, should be accompanied by a reference.

NOTE.—It is against the rules of the Post Office to receive *poste restante* letters addressed either in initials or numbers.

Remarks
ON
POSTERIOR RHIZOTOMY FOR THE
RELIEF OF PAIN.

BY
SIR WILLIAM THORBURN, K.B.E., C.B., C.M.G.,
CONSULTING SURGEON, MANCHESTER ROYAL INFIRMARY.

The operation of posterior rhizotomy has been performed at intervals for the last thirty years; the first recorded case I have met with is one by Bennett,¹ in which some of the posterior lumbo-sacral roots were divided for sciatica, without much apparent benefit. Horsley,² Chipault,³ and others have recorded cases; while Abbé⁴ operated in two instances for intractable brachial neuralgia, excising the posterior roots and ganglia of the affected nerves, the result being that one case was somewhat improved and the other not benefited. The writer and others have also in the past deliberately divided the posterior roots of dorsal nerves in operating for tuberculosis and malignant disease of the vertebrae, with a view to the relief of pain caused by implication of such nerves as they pass through the intervertebral foramina. The earlier scattered cases have given somewhat doubtful results, but in some a persistent neuralgia has been completely cured by the operation.

The whole subject of rhizotomy came more prominently into notice with the publication of Foerster's work,⁵ and was brought before the profession in this country more especially by Hey Groves.⁶ In the *British Journal of Surgery* for October, 1914, are recorded a number of cases by various British surgeons, collected and analysed by Hey Groves, but since this date the war has largely diverted the current of surgical work, and in this country little more attention has been bestowed upon the operation.

Foerster adopted rhizotomy in connexion principally with three conditions—namely, the relief of spastic symptoms in the lower limb, especially those due to the cerebral hemiplegia of infants, the gastric crises of locomotor ataxia, and various types of pain. The present paper does not, however, propose to deal with the division of posterior nerve roots for the relief of spasm, as I have not adopted the operation for that purpose, and from the cases of others which I have observed I am not altogether satisfied as to its value, the difficulty of estimating which is largely increased by the fact that the operation has always been accompanied by careful nursing and instruction. We shall therefore for the present confine ourselves entirely to rhizotomy for gastric crises and for other painful conditions.

RHIZOTOMY FOR GASTRIC CRISES.

Gastric crises are conveniently divided by Foerster into two types:

1. The "lagal," in which there is marked nausea, with but little pain or hyperaesthesia.
2. The "Sympathetic," in which pain and hyperaesthesia are common, but nausea is as a rule not very prominent. It is for the latter type of case that rhizotomy is principally recommended, and Foerster adopts bilateral resection of the dorsal roots from the fifth to the twelfth, with a view to cutting off entirely afferent impression within this area. He records 64 cases collected by himself, of which 6 died, 47 were cured or markedly improved, 9 underwent a certain amount of improvement, and 2 were unrelieved.⁷

In the *British Journal of Surgery* are reported 5 cases with no deaths, 2 failures, and 3 successes, but of the latter, 2 were too recent to allow of reliable inference. To these cases is added a sixth, in which death followed an operation for visceral crises in the bladder. Of the failures recorded in the *British Journal of Surgery*, one was a bilateral operation involving the sixth to the eleventh dorsal roots, and one, which involved only the eighth, ninth, and tenth on both sides, was probably too limited to give much hope of recovery. Of the successful cases, two were bilateral, involving the seventh to the tenth roots, and one case of my own, to which reference will be made immediately, was a unilateral division of the fourth to the eighth on the left side.*

* In every case the numbers given are inclusive; thus fourth to eighth means fourth, fifth, sixth, seventh, and eighth.

Personally I have now performed this operation for gastric crises in three cases; and as two of these date back to the year 1914, they afford sufficient ground for judging of the permanency of the cure.

CASE I.

M., the patient already referred to as reported in the *British Journal of Surgery* for October, 1914, is now 54 years of age. He commenced to have gastric crises at the age of 34, the pain being limited to the left side and associated with copious vomiting. The attacks increased in frequency, and were eventually almost continuous, while the intensity of the pain required him to take large quantities of morphine. In March, 1914, the dorsal roots on the left side only were divided from the fourth to the eighth, both inclusive. Relief of pain was immediate, but three attacks occurred at considerable intervals during the first two years after the operation.

Since then there have been no further attacks, and up to the present time (February, 1921) the patient is entirely free from these. He naturally presents various symptoms of locomotor ataxia, but is quite able to go on with his business, and his general health is good. He presents loss of sensation to pin-prick from the level of the fourth to the eighth dorsal segments, and loss of sensation to cotton-wool over a slightly wider area. There is no tenderness in the abdomen, even on very deep pressure. The sixth, seventh, and eighth motor roots have probably also been injured, as there is a little sinking-in of the lower part of the chest on respiration, and possibly this may be due to degenerative changes in the anterior roots or cornua, as some paralysis was noticed at the time of operation and then passed away in a few days. There are no "trophic" changes of the skin.

CASE II.

B. was admitted to hospital for bilateral pain extending from about the level of the nipple to that of the umbilicus, more intense about the level of the eighth dorsal segment and relieved to some extent by pressure on the epigastrium. Attacks of pain were felt daily and were accompanied by profuse vomiting. I operated upon him in January, 1915, dividing the fifth, sixth, seventh, and eighth posterior dorsal roots, and thus perhaps not extending my section quite far enough down.

In January, 1921, this man was again examined. He presented anaesthesia to pin-prick from the fifth to the eighth dorsal segments on both sides, and to cotton wool over a rather more extensive area. There was no paralysis of any muscles and deep pressure was felt and roughly localized over the whole anaesthetic area; but there was no tenderness even on the deepest pressure over the subjacent viscera. The skin was normal. The patient states that attacks of pain recommenced about six weeks after the operation, and that they have continued ever since; but they now occur about once in six weeks, instead of daily as before the operation. His general condition as regards locomotor ataxia is bad, and he is much crippled by an arthropathy in the right hip, by difficulties of micturition, and by eye troubles, all associated with the primary disease. It is interesting to note that radiographic examination of the stomach showed on one occasion no abnormality, and on another some delay in emptying the viscus.

These two cases, then, present, after an interval of over six years, the one complete immunity and the other relatively great improvement as regards the crises, which alone the operation was designed to meet. The following is more recent, and does not yet offer materials for a judgement as to the end-result:

CASE III.

Mrs. W., aged 47, consulted me in October last, having suffered for twenty years from attacks of pain on the left side of the abdomen, with vomiting, and relief by a rotation of these attacks during the last four years—so that usually they had occurred every three or four days. She had had an operation performed on the gall bladder, but this procedure was not discovered. She presented the usual symptoms of locomotor ataxia, which it is not necessary to detail. On November 8th, 1920, I exposed and resected the fourth to the seventh dorsal roots on the left side, in a manner to the usual band of anaesthesia. The patient had no attacks of pain within the first week or two after the operation, but thereafter ceased to suffer from these for the six weeks during which she remained in hospital.

It will be noted that in these three cases Foerster's dictum as to the bilateral section of the fifth to the twelfth has not been followed, as I was doubtful whether so extensive an operation was essential. In the cases in which pain was limited to the left side the operation was unilateral only; in Case I, which was completely cured, it involved the fourth to the eighth thoracic roots; in Case III, which is so far relieved, the fourth to the eleventh roots were cut. In the partially relieved Case II the operation was bilateral, and concerned only the fifth to the eighth roots.

Apart from the main issue in the above cases, attention may be called to two points, namely, the completeness and permanence of anaesthesia, and the total absence of any

indication of trophic changes in the affected parts; in both of which respects the operation conforms to the results produced by dividing the sensory root of the Gasserian ganglion.

RHIZOTOMY FOR PAINFUL AFFECTIONS OF THE LIMBS.

A considerable number of cases of rhizotomy for pain in the limbs have also now been recorded. Foerster⁸ has collected 44, of which 6 died and 12 were cured, while 23 showed material improvement and 3 were untraced. In the British collection of cases already referred to there are 15 cases: In 1 the operation had to be abandoned, 1 died, and in 1 the result is unknown. Of the 12 which have been followed up, 8 were cured and 4 were failures. Several of the cured cases were examples of neuralgia of very limited type, in which only one root was divided, and more extensive painful affections were often apparently not relieved even by extensive operations. The great majority of the cases concerned the brachial plexus. The conditions for which the operation has been adopted are of the most varied nature. I have operated in two cases:

CASE IV.

A man had an injury to the right brachial plexus, followed by complete paralysis with anaesthesia and pain in the limb. The latter had, when he came under my observation in 1911, been amputated two or three inches below the shoulder-joint, naturally without giving relief. In March, 1911, I exposed the brachial plexus, finding a dense cicatrix, which extended completely up to the vertebral foramina. I excised the entire plexus, but without affording any relief to the pain.

In November, 1911, he was again admitted to my wards, and osteoplastic laminectomy was performed. The fifth, sixth and seventh arches were displaced. On opening the theca in the middle line, the dura mater was found to be closely adherent to the arachnoid on the right side, and had to be dissected away from the cicatrix thus produced. The roots of one only of the cervical nerves, apparently the sixth, were fairly well defined; but the remainder were contained in one cicatrix, which had to be dissected away from the spinal cord without differentiation between the anterior and posterior roots.

Recovery from the operation was uneventful, and the only marked change produced was paralysis of the cilio-spinal fibres, which had escaped or recovered from the original injury. Pain in the upper limb still continued, and two and a half years after the operation the patient wrote that although perfectly well and able to attend to his business, he did not think that he had obtained any material relief. It is clear that in this instance the roots of the plexus were avulsed from the spinal cord, and it is more than probable that changes had extended upwards in the central nervous system beyond the level of these roots.

CASE V.

J. received a bullet wound in the axilla in November, 1914, and in the early part of 1915 came under my care with extensive paralysis and anaesthesia of the left upper limb and severe causalgia. At that time I sutured the ulnar and inner head of the median nerve in the axilla without benefit.

He came under my care again in January, 1921; the muscles of the upper arm were in fairly good condition; he had slight power of flexion and extension of the wrist; all the intrinsic muscles of the hand were much wasted, the skin glossy, the nails long and curved, the wrist displaced to the radial side and the hand partially fixed in the position of pronation. There was continual pain in the palm, extending upwards in the front of the forearm for about one-third of the distance to the elbow-joint—that is, roughly in the distribution of the median nerve; but, although pain appeared to be severe and operation was welcomed, it could no longer be described as typical causalgia. Atrophy and paralysis involved both ulnar and median nerves. No accurate determination of anaesthesia was possible, but there was patchy loss of sensation to both cotton-wool and pin-prick on both front and back of the useless hand; the limb was quite useless. The general health was a good deal undermined by pain and the use of drugs.

On February 3rd, 1921, the fifth, sixth, and seventh cervical laminae were removed, and the sixth, seventh, and eighth cervical and first dorsal posterior roots were divided inside the theca, the ganglia not being excised. The fifth cervical root was not touched, as it was fairly remote from the affected area, and it was not thought advisable to run the risk of injuring motor fibres to the phrenic nerve. This man passed through one or two vicissitudes in connexion with an attack of influenza and sundry functional nervous phenomena, but by the end of

February declared himself free from pain, except for an occasional headache. Anaesthesia did not appear to be quite complete in any part of the limb, except the fingers, but the mental condition made accurate registration impossible. Light touches with cotton-wool were, however, generally not recognized in the area shaded in the diagram, but pin-prick was generally felt in the whole limb, except on the back of the fingers; deep pressure appeared to be recognizable everywhere.

These two cases are sufficiently indicative of the uncertainty of relieving severe neuralgia by posterior rhizotomy, and Case IV shows very clearly how some painful affections of the limbs may be associated with changes extending into the central nervous system. It is, however, remarkable that of the published records the greatest proportion of good results has been obtained in those cases in which, for a limited neuralgia, one root only has been resected.⁹ Beyond all question so limited a resection will not produce anaesthesia in the affected region, and the comparative success of the limited operation must be attributed to some other factor not yet fully explained. The existence of such other factor is also indicated by the success of my comparatively limited operations for gastric crises, and especially by that of Case I. It is also to be noted, both in the case of locomotor ataxia with gastric crises, and of long-standing neuralgia in any region of the body, that the results of operation are

much confused by the highly neurotic condition of the patient. Many of these are accustomed to large doses of morphine, of alcohol, and of other drugs, and when in hospital they feel acutely the absence of such drugs. The case last mentioned showed various phenomena due to this cause. As a further illustration of the instability of the central nervous system in such patients, it is perhaps worthy of note that I have seen a case in which, after removal of the Gasserian ganglion, a typical hysterical anaesthesia involved the side of the body operated upon. A similar case has been recorded by Ormerod.¹⁰

In pleading for a more frequent use of rhizotomy, it appears to me important to point out that the dangers of the operation in practised hands are very much less than would appear from the published results. Thus, Foerster recorded 26 deaths out of 267 operations in which rhizotomy was performed for various reasons; and in the 53 cases collected from the *British Journal of Surgery* we find 6 deaths, the proportion in each case being about 10 per cent. If, however, we investigate the figures of individual surgeons, who have presumably a larger experience in the operation, we find a very different result.

In Burghard's *Manual of Surgical Operations* (1909) I endeavoured to determine the mortality of laminectomy for all causes. An analysis of 50 of my own cases yielded a death rate of 6 per cent., several of which were early cases and were examples of injury or of tuberculous or malignant disease. I was then able to state that "exploratory operations and operations for tumours and allied conditions have been uniformly successful so far as life is concerned; and even in the earlier and more tentative operations for injury there is only one case in which death was probably hastened by operation." At that time I was not able to include any large number of operations for drainage, rhizotomy, or the removal of intrathecal tumours; but since then I have performed many such operations, and the only case of death has been that of an extensive sarcoma involving the cauda equina and conus medullaris, quite irremovable and associated with advanced secondary changes in the bladder and kidneys.

Kuttner has performed rhizotomy 32 times with 2 deaths, Eiselsberg 12 with no deaths, and Elsberg 22 with no deaths. Adding my own to the above cases, we get 71 cases with only 2 fatal results; and every surgeon experienced in laminectomy will agree that the operation *per se* is not more fatal than that of laparotomy. Death is hardly to be contemplated as a result, except in cases where the original disease or the gravely deteriorated general health

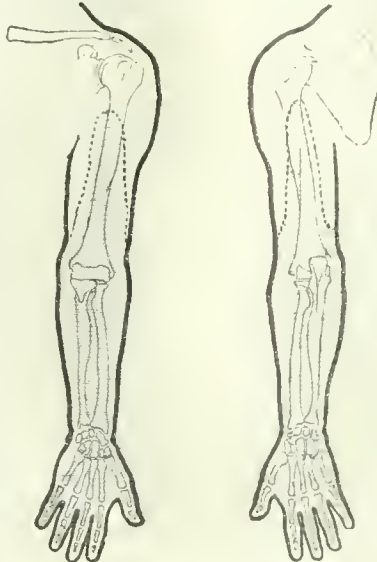

CASE V.

introduces a special and serious factor. Even, therefore, if the results as regards cure of pain are still somewhat uncertain, and if we have more to learn as to the selection of cases and the scope of the operation, it is unquestionably well worth while to give these patients the considerable prospect of cure or relief offered by posterior rhizotomy.

REFERENCES.

¹ BRITISH MEDICAL JOURNAL, 1889, i, p. 945. ² Ibid., December 6th, 1880. ³ Nouvelle Iconographie de la Salpêtrière, 1895, vol. xiv, p. 136 et seq. ⁴ Med. Record, 1890. ⁵ Verhandl. d. deutsch. Gesellsch. f. Chir., 1910, p. 46; Proc. Roy. Soc. Med., Surg. Sect., vol. iv, Part iii, p. 226 et seq. ⁶ Proc. Roy. Soc. Med., July, 1911; Lancet, July 8th, 1911. ⁷ Surg., Gynaec. and Obstet., May, 1913. ⁸ Loc. cit. ⁹ Brit. Journ. Surg., loc. cit. ¹⁰ Royal Society of Medicine, Neurological Section, Presidential Address, 1913.

SYMPTOMLESS HAEMATURIA :

A PLEA FOR EARLY INVESTIGATION.*

BY

JAMES B. MACALPINE, F.R.C.S. ENG.,

HONORARY SURGEON AND SURGEON IN CHARGE OF THE GENITO-URINARY DEPARTMENT, SALFORD ROYAL HOSPITAL.

I wish to direct your attention to the subject of symptomless haematuria, a condition of considerable importance, yet one which receives less attention than it merits; my main object in doing so is to impress on you the fact that such an occurrence is a matter of urgency until a full diagnosis has been made.

"Symptomless haematuria" is a term used to cover all cases in which haemorrhage occurs from the urinary tract unassociated with any other symptom or sign, such, for instance, as pain, urgent or frequent micturition, or a lump. The name is a bad one. In fact it is a misnomer, for haematuria itself, if evident to the naked eye, constitutes a symptom, and its occurrence can therefore never be symptomless. Perhaps it would be better if it were styled "unaccompanied haematuria."

Such unaccompanied bleeding is not at all uncommon, and may be the result of a very considerable number of pathological processes. Indeed there are very few of the many diseases of the urinary tract which do not sometimes give rise to haemorrhage, though with some of them bleeding is characteristic, whilst with others it is exceptional. If you will consider for a moment the vascularity of the organs concerned, it will not seem surprising that this is so. The kidney in particular is an organ of exceptional vascularity, and that portion of the bladder which is most susceptible to disease, namely the trigone, is also very rich in blood vessels.

Yet though so many lesions may be the cause of haematuria, in practice it will be found that unaccompanied bleeding is very suggestive of a urinary neoplasm. Indeed there is a well known dictum which states that "symptomless haematuria indicates a growth of the urinary tract." I quote this phrase to you with diffidence, realizing that medicine abounds with instances of similar dogmata, the majority of which are fertile sources of error and frequently denote a lack of scientific erudition. Yet it is with this probability in his mind that the surgeon will approach the investigation in any given case. That he will frequently find himself mistaken will be impressed on you if I refer to four cases of otherwise symptomless bleeding which have occurred in my own practice recently, and which on further investigation proved to be respectively:

1. A case of scurvy rickets.
2. A case of early renal tubercle.
3. One of that group of cases classified under the title of "essential renal haematuria."
4. Stone impacted in the pelvic outlet, in which, though the patient denied any history of pain, the parenchyma had been markedly encroached upon by back pressure.

Many other causes of symptomless haematuria might be recalled. Yet in a very large proportion of patients who pass blood in their urine without other symptoms, it will turn out that there is a neoplasm of the urinary tract. Walther, in a study of seventy-four cases of haematuria, both accompanied and unaccompanied by other symptoms,

demonstrated that over 50 per cent. were the result of urinary growths, and that of these 72 per cent. were malignant. If his article had only referred to cases of symptomless haematuria the percentage of growths would have been much higher.

Two matters require investigation in all cases:

1. The anatomical point from which the haemorrhage originates.
2. The nature of the pathological processes giving rise to it.

Now I submit that of these investigations the former is a matter of some urgency. The latter could be dealt with at mere leisure, but you must know at the earliest possible moment whether the bleeding is from the upper or from the lower urinary tract, and in the first alternative from which side the haemorrhage is coming. This last is the important thing. A growth in the bladder may be seen when the haemorrhage has disappeared, but symptomless bleeding from the upper tract must be diagnosed during an attack, for then the bloody efflux from one ureteral orifice can be seen and the corresponding kidney, or ureter, held culpable. Remember that in all cases which are truly "symptomless" there is only one real guide, and that is the cystoscope. There is no pain; there is no lump. You may get some doubtful information from the presence of blood well mixed with the urine, which is generally held to come from the kidney; or from the presence of worm like clots which have received their shape from the ureter; but these are unsafe guides, and even they will not tell you from which side the bleeding is coming.

If you wait till there are other symptoms to guide you, you will run the grave risk that the case will become inoperable, yet such procrastination happens with great frequency. Hinman, in an analysis of the published work of eight different surgeons, found that in 709 cases of renal growths haematuria was the onset symptom in 42 per cent., but that when the cases came to operation only 6.6 per cent. showed haematuria unaccompanied either by pain or tumour, and he justly remarks that this "indicates the lost opportunity in making an early diagnosis."

Any of the tumours of the urinary tract is capable of causing symptomless haematuria, and more commonly than not they express themselves in this manner. In order to keep my argument clear I will limit myself to two of the commonest tumours of the tract—namely, papilloma of the bladder and hypernephroma of the kidney. These happen also to be two varieties which very consistently give rise to symptomless bleeding; the former, according to Hurry Fenwick, showing this as its first symptom in 84 per cent. of cases, whilst Israel states that the latter expresses itself thus in 70 per cent.

There is considerable variation in the period of their life history at which they give rise to haemorrhage; in some cases we find that the first bleeding comes from a growth, papilloma or hypernephroma, which from its size must have been growing unsuspected for a long time. But in many cases it is quite early, when the growth is small. Such a haemorrhage coming from a small growth, whether of the bladder or kidney, may not be repeated before months, or occasionally even years, have elapsed, the growth in the meantime having become well nigh untreatable. Surely this gives an uncanny importance to that single manifestation, and throws a grave responsibility on the medical practitioner to see that it is not allowed to subside without having been traced to its source. Generally the duration of that preliminary haemorrhage is not great—it is often only a few days or even hours. Denaclara states that in 146 cases of renal neoplasm only once did the primary haematuria last as long as fourteen days.

These two types of tumour each run a peculiar and almost invariable course, in that each in its earlier stage is non-malignant but in its later stage malignant. The papilloma in the early stage is single, has a long slender pedicle, and does not invade submucous planes. In the later stage it becomes multiple, subsessile or sessile, shows the typical tendency of malignant neoplasms to invade and disseminate, and eventually destroys life by anaemia and cachexia. Singularly enough hypernephroma in its early stages is also a benign growth. It is encapsuled, and it grows very slowly. It may exist in this condition for many years—cases have been reported up to twenty years—behaving in exactly the same way as do parotid tumours.

* A portion of a lecture delivered at the Salford Royal Hospital to a post-graduate class (January, 1921).

Later it also takes on malignant changes, growing more rapidly, invading its capsule and the renal vein, and disseminating. It is remarkable that two growths in the same tract should share this somewhat rare characteristic, but it only makes the importance of an early diagnosis more self-evident, for in the early stage the treatment is that of a non-malignant neoplasm, is easy and satisfactory, and a complete cure can generally be achieved, whilst later the growth becomes malignant and the prognosis proportionately unfavourable.

Nature is, as it were, in each of these cases holding out to us in the early stages the option of successful treatment, if we are but wise enough and shrewd enough to avail ourselves of the opportunity, but she will just as certainly snatch away the proffered chance if we do not seize and secure it, and the indication which she gives us of this dangerous condition is the preliminary haemorrhage which is often so transitory.

To recapitulate, I have tried to show that haematuria is frequently the only symptom of a growth of the urinary tract; that following this expression of its presence it may retire into absolute quiescence for a long period, during which it is probably increasing in size and advancing towards malignancy; that when it reasserts itself, whether by a second haemorrhage, or by pain, or dysuria, or the presence of a lump, it may have passed beyond the operable stage, and that, if the growth should prove to be of the upper urinary tract, the only time at which a diagnosis of the anatomical site can be made is during the period of actual bleeding.

The moral is obvious, but I fear is often missed, and this I wish to impress on your minds. Haematuria is not a symptom to be treated *per se*. It is a red danger sign, urgently demanding an accurate diagnosis—first as regards its anatomical point of origin, and secondly as regards its pathological cause. It is an easy thing to put a patient suffering from acute abdominal pain to bed, and give a hypodermic injection of morphine. Such a course will be followed by relief of the pain; but the profession has long ago learnt the hazard of such a course so long as any doubt remains in regard to the diagnosis. Similarly, it is an easy matter to put a man suffering from haematuria to bed, apply cold, and administer certain reputed haemostatics. Such a course may be rewarded by a cessation of the haematuria, and the medical attendant will have the gratitude of his patient, but surely, on contemplation, must have the mortification of realizing that he has done him a great disservice. Much better had it even been if he had kept him in active life, and rather sought to perpetuate the haemorrhage than to allay it, till such time as a cystoscopic examination could be arranged, and the source of the haemorrhage accurately located. Once the haemorrhage is stopped the opportunity has passed, possibly for a long period, and unless some gross swelling of one kidney can be palpated, or the patient is persuaded to submit to a cystoscopy, which may reveal some causative bladder condition, the golden opportunity has gone by and may not recur till much valuable time has been lost.

Instances of such misguided treatment are unfortunately only too frequent in any urinary practice. I will cite a single case which I have seen comparatively recently. A man had had a short sharp haemorrhage from the bladder three years previously for which he had been treated by his medical attendant with cessation of the haemorrhage. From this point onwards there was no symptom at all till he began to suffer from discomfort in the bladder region and the sensation of incomplete emptying of the bladder even when he had just urinated. Cystoscopy revealed a growth of such large dimensions that examination was difficult owing to the instrument plunging amongst the fronds of a papilloma, which on account of its size had to be removed by suprapubic cystotomy, and when this was done there was revealed a pair of lesser "kiss-cancers" on the opposite bladder wall. If this patient had undergone cystoscopy three years previously his condition would probably have been treated rapidly and easily by diathermy, and the open operation would have been unnecessary.

As the growth gets older the attacks of haematuria tend to become more prolonged, severe, and frequent. On certain occasions I have had to undertake the examination of patients who have been under treatment for continuous haematuria for weeks, a few of these having become abso-

lutely blanched by loss of blood. In one instance a medical attendant informed me that he had attempted to knock off portions of growth by introducing a metal instrument and twisting it about in the bladder—a practice which is condoned in textbooks belonging to a past generation, but which obviously must be condemned in view of the possibility of ocular demonstration by modern methods.

These are the grosser errors, but I have nevertheless been much impressed with the late stage at which urinary growths reach the surgeon, and the consequent difficulty of obtaining good results in these cases. Indeed, if good results are to be obtained, the cases must come up at the first onset of symptoms.

That other urologists find the same trouble I am convinced. Braasch, in an analysis of a series of 83 cases of hypernephroma of the kidney, found that as an average haematuria had existed for more than a year in 77 per cent. before other symptoms precipitated treatment.

As a matter of fact the doctor is frequently not responsible for the delay, for patients often cannot be brought to realize the importance of the condition, so long as it is unaccompanied by pain or discomfort. I have on many occasions been astonished at the complacency with which patients, particularly amongst the uneducated classes, regard it, and have had on several occasions to use considerable pressure to persuade such to submit to a full examination of the urinary tract because they could not understand the importance of the condition. Bransford Lewis records the case of a man suffering from a hypernephroma of the kidney who carried about with him for six years a letter from his medical man to a consultant, in spite of the fact that blood was present in the urine all the time. Similar instances could be multiplied, though the duration in this case was extreme.

I have, however, laid emphasis on the responsibility of the medical attendant, because I consider the importance of an early cystoscopic examination has not been adequately brought home in the past. Had symptomless haematuria been as common as the acute appendix, it would have gone through the same phase that the acute abdomen experienced fifteen years ago, and would now be invariably submitted to immediate cystoscopy, just as the acute abdomen is invariably submitted to immediate laparotomy.

A SEROLOGICAL STUDY OF HAEMOLYTIC STREPTOCOCCI:

DIFFERENTIATION OF STREPTOCOCCUS PYOGENES FROM STREPTOCOCCUS SCARLATINAE.

BY

M. H. GORDON, C.M.G., C.B.E., M.D.,
BACTERIOLOGIST TO ST. BARTHOLOMEW'S HOSPITAL.

(From the Bacteriological Department, St. Bartholomew's Hospital.)

ALTHOUGH definite progress has been made within the last twenty years, knowledge concerning individual races included within the family of bacteria presenting the common morphology of *Streptococcus* is still at an early stage. It is now fifteen years since streptococci commonly met with in disease were investigated by Andrewes and Horder with regard to their biochemical characters (Gordon), their haemolytic power (Schottmüller), and their pathogenicity for laboratory animals, and differentiated into three chief classes of *salivarius*, *faecalis* and *pyogenes*. This classification has stood, and to-day the three groups of *salivarius* or *viridans*, *faecalis* or the enterococcus, and *pyogenes* or *haemolyticus* are widely recognized. As scarlet fever is a disease in which streptococci are constantly present, and have been suspected of primary etiological influence, a special study was made independently by Cumpston and myself of the biochemical characters of the streptococci present on the tonsil and fauces at the onset of scarlet fever. It was found that, as regards the characters in question, the particular streptococcus present there with the greatest constancy and in the greatest abundance could not be distinguished from specimens of *Streptococcus pyogenes* recovered from sources other than scarlatinal.

These past studies of streptococci, however, did not include a scrutiny of their serological characters. As recent investigations have shown in case of both the

pneumococcus and meningococcus that among cocci indistinguishable in biochemical or other respects a number of distinct and apparently fixed serological races or types exist which breed true, it was obviously desirable to investigate streptococci again from this point of view, and to attempt to define the degree of antigenic diversity obtaining amongst them. Accordingly, towards the end of 1919, a study of the serological characters of streptococci occurring in hospital cases was begun on behalf of the Medical Research Council. This survey is still in progress; while specimens of all classes of streptococcus have been included in the investigation, the hospital material examined hitherto has yielded so many more specimens of haemolytic streptococci than of the others that the observations with regard to this group are now sufficiently advanced to submit them to publication.

Preliminary Classification of the Streptococci.

Except in case of blood cultures which are made in broth in the ordinary way, the medium employed for primary isolation is blood agar prepared as follows:

Procedure.

An ordinary agar plate is poured and allowed to set, and then a melted slope of tryptagar is mixed with a little blood from the finger and poured on the top of the agar. The thin surface layer of blood-tryptagar thus superimposed is ample for differentiating haemolytic colonies from others, and the medium is far more transparent, and the differences between colonies more evident than when blood is distributed throughout the medium. After a night's growth at 37° C. the sharply defined halo around colonies of haemolytic streptococci is readily seen on holding the inverted plate against a white background. Colonies of pneumococci and of *Staphylococcus aureus* may also produce a zone of haemolysis, but generally it is of minor degree in this time, and both these cocci are easily distinguished from haemolytic streptococci by the characteristic appearance of their colonies.

A single colony of the streptococcus is now carefully selected and subcultured on to a slope of tryptagar the condensation fluid of which contains a drop of blood. In case of the haemolytic streptococci this condensation fluid shows well marked evidence of haemolysis next morning. Streptococci of the *salivarius* and *faecalis* groups as a rule fail to haemolyse the blood even after several days, but when *S. faecalis* is freshly isolated from the blood stream or from pus it not infrequently produces haemolysis; this coccus, however, is readily detected by the tests applied at the next stage.

The purity of the culture having been verified by microscopical inspection and ensured when possible by subculturing from a single colony on the tryptagar slope, the next step is to test the ability of the streptococcus aerobically to ferment raffinose and mannite, and anaerobically to reduce the colour of neutral red broth. The raffinose and mannite are each in 1 per cent. solution, the solvent being ordinary meat broth with 1 per cent. of Witte peptone and 3 per cent. of salt; this broth is previously freed of its natural sugar content by cultivating *E. coli* in it, and litmus is added as indicator. In case of the neutral red, ordinary meat broth is used with addition of peptone and salt as before, and a suitable depth of colour is obtained by adding 2 c.cm. of a 1 per cent. solution of neutral red (Grubier) per litre. The reactions in these three media can be read off after forty-eight hours at 37° C. In case of some delicate examples of *salivarius* obtained by blood culture in malignant endocarditis, it may be necessary to add a drop of ascitic fluid to each tube in order to obtain growth. The reactions of the three chief classes of streptococcus in these tests is as follows:

Class.	Raffinose.	Mannite.	Neutral Red.
Pyogenes	-	?	-
Salivarius	+	-	+
Faecalis	-	+	+

While the vast majority of haemolytic streptococci fail to change mannite, a few do so. *S. salivarius* is uniformly negative in mannite, and *S. faecalis* as constantly positive in this test. Both *salivarius* and *faecalis* reduce neutral red under anaerobic conditions, but this test is not absolutely necessary; as its haemolytic power differentiates *pyogenes* from the other groups, and the two fermentation tests distinguish between *salivarius* and *faecalis*. It is important not to mistake the bleaching that *S. faecalis* usually produces in broth tinted with litmus for acid production; if the tubes are shaken and allowed to stand the colour returns, and the neutral tint of the raffinose is then seen to be in strong contrast to the acidity of the mannite.

After its physiological characters have been tested in this way and its class determined, the serological characters of the streptococcus are submitted to investigation: Owing to the tendency of suspensions of many of the commonest haemolytic streptococci to undergo spontaneous agglutination, the criterion of mere agglutination was abandoned at an early stage of the

inquiry, and recourse had to the absorption of agglutinin test, which has been found to be of no less value in defining the streptococcus group than it proved previously for a similar purpose in case of meningococci.

Procedure when Applying the Absorption of Agglutinin Test to Haemolytic Streptococci.

The method employed was similar to that used when investigating meningococci. So far little or no difficulty has been experienced in applying the absorption test to streptococci of the *salivarius* and *faecalis* groups. In case of the haemolytic streptococci, however, the difficulties at first were considerable and delayed progress for several months. Eventually these difficulties were surmounted, but in its application to the commonest strains of haemolytic streptococci the absorption test is still far from easy, and occasionally calls for considerable patience. For this reason the following details with regard to technique may be useful.

Preparation of Suspensions.—In order to obtain a dense suspension of the streptococcus, surface plates of tryptagar enriched with ascites fluid have been employed. After incubation for a night at 37° C. 2 to 3 c.cm. of distilled water is poured over each plate and the growth suspended therein. This suspension is examined microscopically, heated to 65° C. for one hour, and well shaken. One-tenth of a cubic centimetre of the suspension is then diluted and its density determined by a turbidity test similar to that employed when estimating the density of suspensions of meningococci. In the case of the majority of the haemolytic streptococci the sole use of this suspension was for saturation tests; the density required for this purpose being approximately 50,000 million particles per cubic centimetre. When working with the *salivarius* and *faecalis* groups far weaker suspensions than this suffice to remove the specific agglutinin from a serum. By adding the required amount of 8.5 per cent. saline the cocci used for saturation are suspended in 0.85 per cent. saline.

Selection of Type Strains.—The cocci used as index or type strains must satisfy two requirements: they must possess good agglutinogenic power, and they must make good suspensions, that is, suspensions of uniform turbidity that do not show macroscopically any auto-agglutination in twenty hours at 55° C. While haemolytic streptococci vary in agglutinogenic power the selection of a good strain for this purpose is comparatively easy by experiment. The majority of strains of the commonest type of haemolytic streptococcus, however, exhibit a strong tendency to spontaneous agglutination, and for this reason are unsuitable for use as type strains. It was by good fortune that the earliest haemolytic streptococcus selected as a type strain was found to form excellent suspensions that were free from this tendency to auto-agglutination. Later on, when another strain was substituted for it, the suspension was not satisfactory until the larger particles had been removed either by filtering the suspension through the thinnest filter paper, or by allowing it to stand in a cylindrical glass (a 100 c.cm. measure) for several hours so as to deposit these heavier particles. Having obtained a satisfactory type strain, it is advisable to make stock cultures of it at once, either on gelatine or egg medium, and to keep them at room temperature, so that should the strain after frequent subculture become supersensitive and take to agglutinating spontaneously, a fresh culture free from this fault can be obtained from the parent culture. This liability to auto-agglutination is especially prominent in specimens of the commonest type of *S. pyogenes*. So far, it appears to be much less developed in examples of other types of haemolytic streptococci; and in case of streptococci of the *salivarius* and *faecalis* groups up to the present little or no difficulty has been met with from this cause.

Preparation of Agglutinating Serum.

Rabbits of from 1,000 to 2,000 grams were used, and the injections given intravenously at intervals of forty-eight hours, dosage being controlled by the animal's weight. The primary dose was 500 million of the killed suspension, and the final dose from 10,000 to 20,000 million. Haemolytic streptococci are weaker in agglutinogenic power to the rabbit than specimens of the *salivarius* and *faecalis* groups. In case of the former a titre of 1 in 400 is usually as much as can be obtained, though 1 in 800 is sometimes possible, especially with the rarer types, whereas in case of the non-haemolytic streptococci serums with titres of 1 in 1,000 to 1 in 2,000 are easy to prepare.

Example of an Absorption Test.

The following are required: (1) A fresh suspension (50,000 million per c.cm.) in saline of each of the cocci to be tested and similar suspensions of the coccus homologous to the serum, and of a coccus of known heterologous type for use as controls.

(2) Sufficient of a dilution (one thirty-second of its full titre) of the type agglutinating serum to allow of 1 c.cm. for saturation with each of the cocci to be tested, and of 3 c.cm. in addition for the three controls—namely: (a) For dilution with saline only; (b) for saturation with the homologous coccus; and (c) for saturation with the heterologous coccus. (3) A centrifuge tube for each of the cocci to be tested and for the three controls. (4) A water bath at 37° C. for standing the centrifuge tubes in while saturation is in progress. (5) Racks of small tubes (3 in. by ½ in.) plugged with wool. (6) A 55° C. incubator.

Procedure.—One cubic centimetre of the diluted serum is placed in each centrifuge tube. One cubic centimetre of saline is added to the first, and a similar amount of each coccus suspension in turn to the rest. The centrifuge tubes are then shaken, placed in the 37° C. water bath and again shaken from time to time. After two hours at 37° C. the tubes are taken out and centrifuged till clear, after which the supernatant fluid of each is put up in four dilutions against an equal quantity (3 c.cm.) of a freshly made suspension (2,000 million per cubic centimetre) of the index coccus homologous to the serum. Two controls of this index suspension are also put up, one against saline, the other against normal serum diluted in the same way as the type serum. The racks are placed in the 55° C. incubator and the result read off next morning.

It is essential that the suspension of the index coccus should not be agglutinated in the controls of saline and of normal serum, and that the agglutinin should be removed by saturation with the homologous coccus, but unaffected by saturation with the coccus of known heterologous type. As a rule, cocci of the same type as the coccus homologous to the serum remove the agglutinin quite as completely as the homologous coccus. If there should be any doubt as to this absorption the test is repeated. The following is an example of the result of a saturation test carried out in this manner:

Type Serum and Coccus S.P.T.(1), Strain M.

No.		1:50	1:100	1:200	1:400
1	Normal serum	-	-	-	-
2	Type serum unsaturated	+	+	+	(+)
3	Type serum saturated with homologous coccus	-	-	-	-
4	Type serum saturated with heterologous coccus	+	+	+	+
5	Type serum saturated with Coccus A	+	+	+	+
6	Type serum saturated with Coccus B	-	-	-	-
7	Type serum saturated with Coccus C	(+)	-	-	-

+ = Weil-marked agglutination.

As regards the controls, No. 1 proves that the index suspension is satisfactory since this has not agglutinated with normal serum; No. 2 shows that the agglutinin of the type serum is active; and No. 3 and No. 4 show that this agglutinin is absorbed by the homologous coccus, while it is unaffected by saturation with the heterologous coccus. Of the remaining three cocci, A fails to remove the agglutinin and is therefore of heterologous type, while both B and C have absorbed it, and therefore are homologues of the type coccus and agglutinin here employed. In the case of Coccus C, the saturation can if desired be repeated, since a trace of agglutinin still remains unabsorbed in the first dilution; but this is hardly necessary, since over three-quarters of type agglutinin has been absorbed; a degree of reduction that no coccus of heterologous type could effect.

Serological Types of Haemolytic Streptococci.

All the haemolytic streptococci submitted to serological investigation had been found to exhibit the cultural and biochemical characters of *S. pyogenes*. By the absorption of agglutinin test these streptococci have been resolved so far into three different types. In considering the frequency and distribution of these types it will be convenient to deal with the streptococci according to the sources from which they were isolated, and to take them in the following order:

1. Haemolytic streptococci from the tissues in ordinary hospital cases.
2. Those from cases of puerperal sepsis.
3. Those from the respiratory tract in various conditions.
4. Those from the tonsil at the onset of scarlet fever.

1. Haemolytic Streptococci from the Tissues of Ordinary Cases.

Either localized streptococcal infections or cases of streptococcal septicaemia or meningitis furnished all of

the 68 streptococci now under review. The actual sources and the number of specimens from each were as follows: Cellulitis 15, erysipelas 3, abscess 9, arthritis 5, meningitis 8, empyema 4, osteitis or osteomyelitis 3, otitis media 2, peritonitis 1, ophthalmitis 1, and impetigo 1. Streptococci were obtained by blood culture during life from one case of pyrexia of uncertain origin, from two cases of cellulitis, from a case of mastoiditis, and from one of pyelitis. Eleven streptococci were recovered *post mortem* from the heart's blood of the following cases: Trauma with septic wounds 2, septicaemia after hysterectomy for cancer 1, terminal septicaemia in pernicious anaemia 1, in secondary anaemia 1, in nephritis 2, in bronchopneumonia 2, in strangulated hernia 1, and in a case of gangrene of the leg.

No fewer than 66 of these 68 haemolytic streptococci were found to absorb the specific agglutinin prepared against one of them, and the group which they form was accordingly designated Type I. The two non-absorbing streptococci were injected into rabbits and agglutinin prepared against each, with the result that the cocci were found to represent two different types. The first of these streptococci, designated Type II, had been obtained in pure culture from the heart's blood of a rapidly fatal case of influenzal pneumonia. The last streptococcus, Type III, had been isolated from an ear discharge developed a few days before death by a girl of 9 in the last stages of rheumatic endocarditis, and was also recovered from the bronchial secretion after death.

2. Haemolytic Streptococci from Cases of Puerperal Sepsis.

Streptococci possessing the cultural and fermentative characters of *S. pyogenes* were isolated from ten cases of puerperal sepsis and examined. The actual sources from which they came were as follows: Cervical secretion 2, blood culture during life 5, blood culture after death 2, and one streptococcus came from the peritoneal pus in a case of abortion. On submitting them to the absorption of agglutinin test all of these ten streptococci proved to be specimens of Type I.

3. Haemolytic Streptococci from the Respiratory Tract.

Streptococci with the characters of *S. pyogenes* were isolated from the following materials: One specimen each from nasal secretion in chronic rhinitis and from laryngeal secretion in Ludwig's angina; two specimens from tuberculous sputum, and two more from the post-nasal secretion in chronic post-nasal catarrh. On submitting them to the absorption of agglutinin test all of these six streptococci proved to be examples of Type I.

Bronchial Secretion.—In order to determine the serological characters of haemolytic streptococci occurring in bronchial secretion this material was obtained *post mortem* at the bifurcation of the trachea and examined in 27 cases. No fewer than eighteen of these specimens of bronchial secretion failed to yield haemolytic streptococci. Although twenty of the cadavers showed pulmonary lesions, haemolytic streptococci were only isolated in nine instances. The positive cases were as follows:

(1) A girl of 9, with rheumatic "pancarditis" and terminal bronchopneumonia; (2) a man of 24 with acute pleurisy and myocarditis, fatal within forty-eight hours; (3) a child of 6 with bronchitis and empyema; (4) two men, one of 57 the other of 58, with septic pneumonia associated with breaking down of carcinoma in the lung; (5) a baby of 1 year and 3 months who had succumbed to acute bronchopneumonia—in this case the bronchial secretion showed chiefly *B. influenzae*, but a haemolytic streptococcus was associated with it, both in the bronchial secretion and in the heart's blood; (6) a man of 35 with tuberculous bronchopneumonia and meningitis; (7) a girl of 24 with morbus cordis and bronchopneumonia; (8) a man of 23 with bronchiectasis and amyloid disease of the kidneys, liver and spleen.

Out of the 9 haemolytic streptococci thus obtained from bronchial secretion no fewer than 8 were found by the absorption of agglutinin test to be examples of Type I. The single exception came from Case (1): It proved to be a specimen of Type III, and identical with a haemolytic streptococcus obtained from the ear discharge of this same patient a few days before death.

Tonsils.—The tonsil has been investigated for haemolytic streptococci by two different procedures—namely, either by direct examination of the freshly excised tonsil, or by swabs taken in the ordinary way. The opportunity of examining the freshly excised tonsils I owe to the

courtesy of Mr. T. H. Just, F.R.C.S., who removed them in course of his routine duties.

The tonsil was held in a piece of clean filter paper and its surface seared with a hot iron, the capsule slit open with a sterile knife, and three loopfuls of the contents distributed in 3 c.cm. of broth. A drop of this broth was then spread over the surface of a blood-tryptagar plate, and any haemolytic colonies isolated and examined. When dealing with swabs, the swab was stood in a tube containing 3 or 4 c.cm. of broth and well shaken; a drop of the broth was then carefully spread over a blood-tryptagar plate. The results were as follows:

Results.

Excised Tonsils.—Out of 24 tonsils removed from children for hypertrophy, and showing no definite naked-eye evidence of sepsis, 8 yielded a growth of haemolytic streptococci. Five of these streptococci proved to be specimens of Type I, one was a specimen of Type II, and two were specimens of Type III. Definitely septic (purulent) tonsils were examined after removal from two patients, the first of whom had developed rheumatic symptoms and endocarditis; in both cases the tonsils were heavily infected with a haemolytic streptococcus of Type I.

Swabs taken of the tonsil in four cases of acute tonsillitis yielded in three instances specimens of *S. haemolyticus* Type I, and in the fourth a haemolytic streptococcus apparently different from all the three defined types and not yet identified. A case of follicular tonsillitis and two cases of early measles accompanied by angina each gave a specimen of *S. haemolyticus* Type I. In three cases of diphtheria a haemolytic streptococcus accompanying the Klebs-Loeffler bacillus was a specimen of Type I. During an outbreak of infectious catarrhal sore throat in a school, six children in the acute stage and twelve convalescent children were swabbed by my colleague Dr. Richard Armstrong, and a special search made for haemolytic streptococci on blood-tryptagar plates. Only one case was positive, and the streptococcus there present proved to be a specimen of Type I.

Summary.—Out of a total of 21 haemolytic streptococci isolated from the tonsil and investigated 17 proved to be specimens of Type I, 1 of Type II, and 2 of Type III; one specimen could not be identified with any of these types. Including the haemolytic streptococci from all parts of the respiratory tract a total of 36 specimens have been investigated, of which 31 proved to be specimens of Type I, 1 of Type II, 3 of Type III, and one could not be identified.

The distribution of serological types among all the haemolytic streptococci examined up to this point is as follows:

Source.	Specimens.	Type I.	Type II.	Type III.
General	68	66	1	1
Puerperal sepsis ...	10	10	0	0
Respiratory tract ...	36	31	1	3
Total	114	107	2	4

The outstanding feature of these results is the pre-dominance of Type I, which undoubtedly represents the commonest form of *Streptococcus pyogenes*. It is of interest to recall that Hammetton examined six specimens of this streptococcus serologically and found them identical, and further, that in a recent monograph Douglas, Fleming, and Colebrook report a similar serological identity among twenty-four specimens of *S. pyogenes* isolated from war wounds. The last observers also found that the mannite-fermenting form of *S. pyogenes* is serologically identical with strains not fermenting mannite—a point which I can confirm, as 3 of my 107 specimens of Type I fermented mannite, while the remaining 104 failed to do so.

A further point calling for notice is that specimens of all the types of haemolytic streptococci were obtained from the respiratory tract. The two specimens of Type II came respectively from the heart's blood of a fatal case of influenza pneumonia and from a hypertrophied tonsil. The four specimens of Type III came from three patients—two specimens from hypertrophied tonsils, the other two from the ear discharge and bronchial secretion respectively of a girl of 9 who succumbed to rheumatic carditis. It may be mentioned that among 125 haemolytic streptococci obtained chiefly from the respiratory tract during an outbreak of bronchopneumonia, Dochez, Avery, and Lancefield distinguished at least four different types by agglutination and by protection tests, and consider that further types exist in this locality.

4. Haemolytic Streptococci from the Fauces at the Onset of Scarlet Fever.

Having prepared the way by these control observations, I was now in a position to investigate the serological characters of haemolytic streptococci occurring in the tonsillar and faucial secretion at the onset of scarlet fever. From previous observations made on behalf of the Local Government Board it was known that at the earliest stage of scarlet fever a streptococcus indistinguishable from *S. pyogenes* in cultural and biochemical respects and virulent to the mouse occurs there with great constancy and abundance. It was of much interest, therefore, to see if this scarlatinal streptococcus is serologically identical with any of the defined types of haemolytic streptococci, and the present investigation appeared to be the more timely since observations recently published in America by Tunnickliff and Bliss had indicated that this scarlatinal streptococcus is serologically distinct from *S. pyogenes*.

For the present purpose it was indispensable to obtain material from cases of scarlet fever within the first week, and so typical clinically as to be beyond all doubt. Through the courtesy of Dr. Ford Caiger and the assistant medical officers of the South-Western Fever Hospital, I was provided with swabs from ten such early cases of scarlet fever. These swabs were treated in the same way as those described in the preceding section. Nine of them gave a profuse growth of colonies of haemolytic streptococci which in four cases far exceeded all other bacteria in abundance on the plates. From different parts of each positive plate two haemolytic colonies were subcultured and the cultural and biochemical characters of each streptococcus examined, with the result that all were found to be indistinguishable from *S. pyogenes* in these respects. Two of the streptococci that formed the best suspensions—each from a different case—were injected into rabbits and agglutinin prepared against each of them.

It was found that none of these 18 scarlatinal streptococci absorbed the agglutinin of either Type I or Type II *S. haemolyticus*.

On proceeding to carry out absorption tests with the agglutinin prepared against the two selected scarlatinal streptococci it was found that these two streptococci were identical, since each absorbed the agglutinin of the other equally as well as its own. Of the 18 scarlatinal streptococci 16 were found to absorb this agglutinin, and among these 16 was at least one streptococcus from each of the 9 positive cases. Specimens of each of the three defined types of haemolytic streptococci were now put up against the agglutinin of the scarlatinal streptococci, with the result that while Types I and II failed to remove it, Type III absorbed the agglutinin equally as well as the scarlatinal streptococci. It would appear, therefore, that the scarlatinal streptococci are identical with Type III.

Two of the haemolytic streptococci isolated from the scarlatinal throat failed to absorb the agglutinin from the serum prepared against the scarlatinal cocci, and also failed to absorb the agglutinin of the three types of *S. haemolyticus* previously defined. These two streptococci, therefore, are as yet unidentified.

SUMMARY.

1. By the absorption of agglutinin test haemolytic streptococci have been differentiated up to the present into three distinct groups or types.

2. Of these Type I is by far the largest. To this serological group belong the vast majority of specimens of haemolytic streptococci from localized or general streptococcal infections, from cases of puerperal sepsis, and from infections of the respiratory passages other than scarlet fever. Type I, in fact, represents *Streptococcus pyogenes*.

3. So far Type II is rare: only two specimens of it have been obtained.

4. Type III is chiefly to be found in the secretion on the tonsil and fauces in scarlet fever. Serologically this *Streptococcus scarlatinar* is quite distinct from *Streptococcus pyogenes*. The observations of Tunnickliff and Bliss to that effect are confirmed.

In view of this serological individuality of the haemolytic streptococcus present in the angina of scarlet fever it is clear that we must be prepared to revise our views on its significance in that disease. The opinion that this streptococcus represents merely a secondary infection in scarlet fever was based mainly on the view that it is

indistinguishable from specimens of *S. pyogenes* recovered from sources other than scarlatinal. This view is now untenable. The possibility, therefore, must be realized that the streptococcus in question may ultimately be established as the essential cause of scarlet fever. Its exact significance, and also its practical application as regards the diagnosis and specific treatment of scarlet fever have still to be decided. As the problem is one of considerable practical interest and importance, it is hoped that the present communication may be of use to others who may have the opportunity and inclination to investigate the matter.

In conclusion, I wish gratefully to acknowledge the help received from my colleagues at St. Bartholomew's and from Dr. Caiger in obtaining material for this investigation, and also to record the valuable assistance of Mr. J. Heagerty, my laboratory assistant, in applying the absorption test to the relatively large number of haemolytic streptococci that it has been necessary to examine.

BIBLIOGRAPHY.

- Andrewes and Horder: A Study of the Streptococci Pathogenic for Man, *Lancet*, September, 1906.
 Cumpston: The Relative Frequency of Various Types of Streptococci in Scarlatina, *Journal of Hygiene*, vii, 1907, 599.
 Gordon: Fermentative Characters of Streptococci present on the Fauces during Scarlet Fever, *Report Med. Off. Local Govt. Board*, 1910-11, 302.
 Haunerton: Differentiation of the Strains of Streptococci from Cases of Latent Sepsis, *Journal R.A.M.C.*, xxxiv, 1920, 426.
 Douglas, Fleming, and Colebrook: Studies in Wound Infections, Medical Research Council, Special Report Series, No. 57, London, 1920, 53.
 Dochez, Avery, and Lancefield: Antigenic Relationships between Strains of *Streptococcus haemolyticus*, *Journal Exper. Med.*, xxx, 1919, 179.
 Tunnichiff: Specific Nature of the Haemolytic Streptococcus of Scarlet Fever, *Journal Amer. Med. Assoc.*, lxxiv, 1920, 1387.
 Bliss: A Biological Study of Haemolytic Streptococci from the Throats of Patients suffering from Scarlet Fever, *Bull. Johns Hopkins Hospital*, xxxi, 1920, 173.

Remarks

ON

POSTURAL OR SO-CALLED STATIC DEFORMITIES.

BY

A. S. BLUNDELL BANKART, M.Ch., Cantab.,
F.R.C.S. Eng.,

ORTHOPAEDIC SURGEON, MIDDLESEX HOSPITAL; SURGEON, ROYAL NATIONAL ORTHOPAEDIC HOSPITAL AND HOSPITAL FOR EPILEPSY AND PARALYSIS, MAIDA VALE.

(Concluded from page 590.)

II.

In the first part of this paper¹ I gave a brief account of the physiology of posture, based on the work of Sherrington, who has shown that the upright attitude or posture of the body is maintained by continuous tonic reflex muscular activity. It was seen that this "postural activity" is of a special kind, quite different from the muscular contraction which gives rise to movement; that it is capable of being maintained for long periods without fatigue; and that it is controlled by a special nervous mechanism of its own. Attention was directed to the profound influence which the higher parts of the central nervous system exert upon postural activity, both in health and disease, and I endeavoured to show the practical bearing of these observations on the etiology and treatment of curvatures of the spine. Postural deformities are due to deficient postural activity, and the following pages deal with the application of this principle to flat-foot and other deformities hitherto described as "static."

FLAT-FOOT.

There are still some people who believe that the arch of the foot is supported by ligaments, and that the muscles merely serve to move the foot in obedience to the will. This view is utterly opposed to our conception of the function of ligaments and of the physiology of posture.

The natural form of the foot as a whole is determined by the shape of the individual bones, whose articular surfaces are adapted to one another in what may be called the neutral position of the foot.

The ligaments keep the several bones in normal apposition, resisting gross displacements, and helping to restore the bones to their normal resting positions after the slight displacements which continually occur during ordinary use of the foot. To this extent, and to this extent only, the form of the foot is maintained by ligaments.

It is not the function of ligaments to withstand continuous strain; this is a function of muscles. The correct attitude of the feet in standing is a part of the postural reflex which maintains the body as a whole in the upright position. The mechanical force of gravity in the upright position tends to abduct and evert the feet, and this actually happens in a child learning to walk before the postural reflex is established. The postural reflex, in so far as it concerns the feet, consists of adduction and inversion—which does not mean that the feet are visibly held in that position, but that the tendency to passive abduction and eversion by the body weight is continuously resisted. Incidentally, the inner border of the foot is drawn upwards to a greater or less extent, so as to form an arch, and the body weight is taken up by the postural muscles and distributed to the outer border of the foot, the heads of the metatarsal bones and the heel.

From this time onwards the normal attitude of the foot, including the arch, is maintained by continuous reflex muscular activity. This postural activity, as we have seen, is of a special kind, capable of being maintained continuously for long periods without fatigue, and controlled by a special nervous mechanism of its own.

Flat-foot is either caused by, or accompanied by, deficient postural activity. Some of the conditions which may modify or inhibit the postural reflex have been considered in connexion with scoliosis. Mental fatigue or inertia, temperament, occupation (apart from prolonged standing), anaemia, constipation, adenoids, etc., all have a place in the etiology of flat-foot as in that of scoliosis. The deficiency of postural activity may be manifested generally or locally. Some patients develop postural scoliosis or kyphosis, others postural flat-foot, while in many cases scoliosis and flat-foot are associated in the same individual as parts of a general loss of tone. Not infrequently there are accompanying vasomotor disturbances—for example, flushing, profuse sweating, susceptibility to chilblains, oedema, etc., significant of the functional (perhaps sympathetic) origin of the deformity.

But, although postural activity is capable of being maintained for a long time without fatigue, there is a limit to the amount of strain that even a postural muscle can stand, and under modern conditions of civilization the strain thrown on the feet is often far in excess of anything that Nature intended. The result is that in many cases simply by continuous standing the postural reflex is at last tired out, and the body weight, overcoming the resistance of the muscles, passively abducts and everts the feet. Prolonged standing is thus one of the commonest causes of flat-foot in adults. It is hardly necessary to point out that conditions which give rise to a primary deficiency of postural activity may be, and frequently are, combined with occupations which entail long hours of standing, so that both causes may operate together, and no sharp dividing line can be drawn between these two groups of cases.

There is a third class of case in which the postural reflex is inhibited by some local condition. Pain in the foot inhibits the local postural reflex. Flat-foot, therefore, commonly follows sprains, fractures, or other injuries of the foot (traumatic flat-foot) and painful inflammatory conditions, such as gout, rheumatism, gonorrhoea, etc. (inflammatory flat-foot). With regard to the last named affection, it may be said that reflex inhibition from pain has far more to do with the causation of gonorrhoeal flat-foot than has any inflammatory softening of the ligaments, as commonly described in the textbooks.

Cases of flat-foot, therefore, fall roughly into three groups:

1. Those in which the immediate cause is deficient postural activity;
2. Those which are due to continuous strain by which the postural reflex is exhausted; and
3. Those in which the local postural reflex is inhibited by some painful condition of the foot itself.

Pain in the foot not only inhibits the local postural reflex, but it frequently induces an abduction-eversion spasm, which is a fixation of the flexion reflex commonly evoked by painful stimulation of the foot. Spasm, therefore, is

¹ BRITISH MEDICAL JOURNAL, April 23rd, 1921, p. 587.

usually present in cases of traumatic and inflammatory flat-foot, and it occurs also in a certain proportion of cases which are due to standing. It never occurs in the cases due to a primary postural deficiency.

It is common knowledge that a very considerable distortion of a joint may be brought about slowly and gradually in the course of time without provoking pain or spasm. But rapid distortion of a joint is painful, and quickly resented by spasm of the muscles acting on the joint. Thus it happens that, when flat-foot develops slowly and gradually, as it usually does, it is unaccompanied by spasm, but when the deformity develops rapidly, it is likely to be accompanied by spasm. Spasmodic flat-foot is rapid and painful flat-foot. Spasm does not occur in the cases primarily due to deficient postural activity, because in them the deformity develops gradually, and is practically unresisted. It occurs in some of the cases which result from prolonged standing, because in them there is no primary loss of tone, the foot is in fact crushed down against resistance, so that the whole foot is strained, and the rapid distortion which results sets up a reflex protective spasm.

The arch of the foot is, perhaps, the least important thing about this badly named deformity. Some people have naturally high arches, and some have low ones. A very considerable amount of distortion and pain in the foot may occur before there is any apparent sinking of the arch, and some of the severest symptoms of flat-foot are met with in feet which are not flat. On the other hand, the arch may be low or even flat without any other symptom of flat-foot, and it does not follow that such a condition is pathological. Many barefooted savages have absolutely flat feet, yet they are perfectly normal. Their feet are strong and supple, they grip the ground as they walk, and they adapt themselves perfectly to every call that is made upon them.

The only thing that matters is whether the postural muscles take up the strain of the body weight, as they should, and distribute it to the best advantage to the natural points of support of the foot, or whether they are inefficient and allow the body weight to fall continuously unrelieved upon the joints and ligaments of the foot, so as to strain them and distort them and give rise to symptoms.

TREATMENT OF FLAT-FOOT.

The treatment of flat-foot is (1) to restore the natural form of the foot, if necessary; (2) to relieve the postural muscles from strain, or in other words, to keep the foot in the correct position during the period of recovery; and (3) to re-establish the postural reflex.

1.

If the foot is rigid or fixed by spasm, its natural form cannot be restored until it is made supple. Such feet, therefore, may require forcible correction and immobilization as a preliminary measure. I have, however, come to believe that spasmodic flat-feet can be made to yield to the corrective influence of a properly shaped boot, and I very rarely employ forcible correction and plaster now.

2.

Forcible abduction and eversion of the foot by the body weight throws a tremendous strain on the postural adductors, and these muscles cannot recover their function unless they are relieved from strain. It is necessary, therefore, before postural activity can be restored, to keep the foot constantly in a correct position, so that the muscles are relieved from strain. It is true that when the foot is supple this position can be voluntarily assumed. But voluntary muscular action is quite different from postural activity, and it cannot be sustained on account of fatigue. It is necessary, therefore, to employ some artificial means of securing the correct position during the period of recovery.

I have never been able to persuade myself that it is a rational or a scientific procedure to put a rigid support (foot-plate, arch support) under the arch of the foot. In the normal foot the inner border or arch is raised off the ground; there is an empty space beneath it, and obviously it was never meant to rest upon anything. It is also rather a tender part of the foot, and direct pressure upon it is not, as a rule, well borne. A rigid moulded arch support creates quite an artificial condition; it converts the elastic foot

into a rigid system, and I cannot but believe that it prevents that muscular re-education which is essential to true recovery.

Of course, if one starts from the point of view that flat-foot is incurable, it may seem rational to establish an artificial condition in which the arch is mechanically supported from below, as upon a crutch. But as a routine procedure, this seems to me to shirk the real treatment of flat-foot, just as the indiscriminate use of spinal supports in scoliosis is a confession of failure. Our experience is that comparatively few patients can tolerate rigid foot-plates, and that those who do can hardly ever dispense with them.

In the absence of normal muscular control the correct position of the foot is a question of balance rather than of support. The human foot has no true stability of its own. There is a mid position, on one side of which the body weight thrusts downwards and inwards, causing abduction and eversion of the foot, and on the other side of which the body weight flows downwards and outwards, the foot being adducted and inverted. There is no mean resting place, no point of stability in the mid-position. It follows, therefore, that the foot must be kept adducted and inverted to just beyond this mid position in order that the postural muscles may be relieved from strain. This result can be obtained by giving the foot a tilt in the boot sufficient to throw the body weight definitely over to the outer side of the middle point. Nothing short of this degree of tilt will suffice; anything over it is enough.

To apply this principle in practice the foot must be held in a boot that fits well enough to make the foot follow its movements. It is then common practice to give the whole boot a tilt by raising its inner side. This is the principle of the so-called valgus wedge. A valgus wedge that is not sufficient is as useless as no wedge at all. One frequently sees boots with valgus wedges on patients who nevertheless crush down their arches, because the body weight still falls inwards. It is entirely irrational to prolong the heel in such a case, so as to support the waist of the boot from below. If the waist is crushed down the tilt is insufficient. If the tilt is sufficient the waist of the boot is not crushed down, and a prolonged heel is superfluous.

In my experience the simple valgus wedge commonly fails because the insole of the boot, although tilted, is still a plane surface. Upon an inclined plane surface the foot cannot find its natural points of support, but it slips bodily towards the lower or outer side, where it comes to rest against the "upper" of the boot. The natural points of support of the correctly placed foot are the heads of the metatarsal bones, especially the first, the outer border, and the heel. These parts of the insole must be depressed or "bedded," so that the foot may drop into them, and, if this is correctly done, the foot will adapt itself to the insole and assume its correct position. I have come to regard the moulded insole as the best of the artificial means of controlling the supple flat-foot, and I have found that at least some cases of rigid and spasmodic flat-foot will yield in time to this device.

3.

The only real cure of flat-foot is restoration of the local postural reflex. In cases of primary postural deficiency the treatment of the patient is of first importance. The general treatment of postural deficiency and of the conditions which give rise to it is indicated in postural flat-foot, just as in cases of postural scoliosis.

When the postural deficiency is local and merely incidental to the deformity, the treatment of the foot comes first. If the foot is supple, the patient can voluntarily invert it and stand on its outer border. This action is the same as that of the postural reflex, with this difference—that it is voluntary and phasic and therefore cannot be maintained, whereas the postural reflex is subconscious and tonic and capable of being continued for long periods without fatigue. The postural reflex can, however, be re-educated by voluntary action constantly repeated until it becomes habitual—or in other words, by exercises.

There is only one exercise which need be done for flat-foot, and that is the movement of inversion—getting on to the outer borders of the feet. The patient should be told not to make a set "exercise" of it, but to do it always, everywhere, whenever he is standing about, to make a

ridget of it, until it becomes a habit and the attitude which it induces becomes habitual.

Set exercises t.d.s. do not make habits. A complicated series of exercises, if ordered, will be done, only at certain fixed times, and the patient will not make of them a habit, as he will of a single simple movement which can be done at all times, anywhere, without preparation, and with hardly a thought. As a matter of fact, the majority of exercises are conceived with the totally erroneous idea of strengthening or developing certain muscles. Postural deformities are not due to weak muscles, but to deficient reflex activity. The object of exercises is to re-educate a reflex, and this is done by voluntary effort constantly repeated until the action becomes habitual or reflex.

There is only one person who can cure a flat-foot, and that is the person who has got it. The patient should be made to realize this, and his active co-operation should be secured. I have been accustomed to say that within limits the cure of flat-foot depends more on the patient's head—that is, his intelligence and co-operation—than on the state of his feet.

It is futile to order massage in an ordinary case of flat-foot or scoliosis. The patient who is having massage, and especially the patient who is paying for it, expects to be cured, and gets no further than that.

COXA VARA: GENU VALGUM.

There are certain other deformities which I cannot help thinking will eventually come to be included among postural deformities. They are particularly the coxa vara and the genu valgum of adolescents, hitherto described as constitutional, idiopathic, non-rachitic, non-traumatic—in other words, their pathology is unknown.

I quite agree that the more carefully one goes into the history of cases of coxa vara, the more often will one obtain a history of some preceding injury. But there still remains a group of cases in which injury can be definitely excluded, and I do not think that anyone claims a traumatic origin for adolescent genu valgum.

We have, then, a condition in which a bone or part of a bone which is normally subjected to great stress and strain from weight-bearing in the upright position, for some reason or other fails to resist that stress and strain, and becomes slowly deformed in consequence. All these cases show also flat-foot or other signs of deficient postural activity.

Now, every functional use of a tissue is in a sense an injury, or at least a stress and strain, to which the tissue reacts by calling to itself an increased blood supply. This is a local vascular reflex evoked through the sympathetic, and it is the normal mechanism whereby increased nutrition is secured to every functioning tissue, including bone. It is the explanation of the increased growth and development of a part which results from use, and conversely, the absence of this reflex is the explanation of the atrophy which results from disuse and still more so from paralysis. It may be taken as the physiological basis of Wolff's law, which briefly states that form and structure are determined by function. There is no evidence of the existence of any specific trophic nerves to the tissues of the body.

Now, if we rid ourselves of the idea of the older anatomists and pathologists that bone is a rigid unalterable structure, and if we regard bone as a living plastic material constantly undergoing changes of absorption, new formation and rearrangement, a structure which meets stresses and strains not by merely sitting under them, but by actively responding to them, calling to itself by reflex action increased nutrition, so that it may strengthen itself against them—in short, if we form a physiological and dynamic conception of bone rather than an anatomical and static one—we shall be able to view these deformities in a different light from that which has hitherto been usual.

We can picture to ourselves a bone suffering from the stress and strain of normal weight-bearing, and calling for that increased blood supply and nutrition which is so necessary but does not come, because for some reason or other the vascular reflex is in abeyance. In such circumstances, instead of strengthening itself to meet the stress and strain the bone simply becomes weaker, because function without physiological adjustment of blood supply, that is, nutrition, is pure destruction.

Thus we begin to see how a functional nervous condition might conceivably bring about such a surprising thing as actual structural alteration and deformity of a bone. For structure is the outcome of function; function is inseparable from nutrition; nutrition in functioning tissues is entirely a question of a co-ordinated blood supply, and the normal mechanism for co-ordinating the blood supply to any part is by means of reflex action through the sympathetic nervous system.

This activity of bone may indeed be described as postural. For, just as a postural muscle is called into activity by impulses arising within itself in response to the stimulus of gravity, so is the bone called into a state of physiological activity by impulses arising within it in response to the stimulus of weight-bearing.

A peculiar interest, therefore, attaches to the evidence which has been brought forward as to the sympathetic innervation of skeletal muscle, and to Sherrington's observation that the activity of the muscular walls of the blood vessels (which, of course, are supplied by the sympathetic) is also postural, that is, it exhibits the same features of plastic tonus—adaptability without change of tension, the lengthening and shortening reactions, etc.—as posturally acting skeletal muscle. These observations go to show that there is a close relation between postural activity of skeletal muscle and the weight-bearing capacity of bone, both being under control of the same nervous mechanism, and therefore liable to be affected by the same disturbances, whether functional or organic.

There is also an anatomical relationship between postural activity and weight-bearing. The internal structure of cancellous bone has been described as a "crystallization of lines of force"—that is, the lamellae are arranged in lines corresponding to the principal stresses and strains falling on the bone. In the trunk and lower extremities, at any rate, these lines are determined by the habitual positions of the bones in relation to the force of gravity in the upright position. These habitual positions are determined by postural activity, and any deficiency of the normal postural activity will therefore cause the lamellae of the bones concerned to come out of alignment with the force of gravity.

Anatomists describe certain mechanisms—for example, the Y-shaped ligament of Bigelow at the hip-joint and the locking mechanism of the knee-joint in full extension—whereby it is claimed that the upright position can be maintained without the necessity for continuous muscular action at these joints. But, as a matter of fact, the upright position is maintained by continuous muscular action, and these mechanisms do not come into action in the natural attitude of standing. It is true that when the muscles of the hip and knee are paralysed, stability may be secured by hyper-extending these joints until the checking action of the ligaments comes into action; but this is quite abnormal. In ordinary standing both the hip and knee are slightly flexed, and they can at any moment be extended or hyper-extended by an effort, but the attitude thus assumed is unnatural, irksome and fatiguing.

Deficiency of postural activity brings the lamellar structure of bone out of alignment with the force of gravity. The natural reaction of the bone is to bring about a rearrangement of the lamellae in accordance with the altered direction of the stress and strain. But this is a slow process involving absorption and new formation of the lamellae, and meanwhile the bone is at a great disadvantage as regards its weight-bearing capacity.

I would put forward the view that lack of resistance, that is, inability to withstand the strain of weight-bearing, in parts of the bony skeleton may equally well be a result of deficient postural activity, as is the corresponding default of the postural skeletal muscles.

Thus, to deficient postural activity of central origin, as already described, we may assign some of the cases of coxa vara, genu valgum, and I may now add the osseous deformity of postural scoliosis, all coming on slowly at about the age of adolescence, and all associated with deficient postural activity of muscle.

CONCLUSIONS.

Postural deformities are due to default of the normal mechanism for maintaining the body in the upright attitude.

This mechanism is a nervous one, for it has been shown by Sherrington that the upright attitude or posture of the

body is maintained by tonic reflex muscular activity (postural activity).

Postural activity is of a special kind, capable of being maintained for long periods without fatigue, and controlled by a special nervous mechanism of its own. It is quite distinct from phasic or voluntary muscular contraction.

There is evidence that the sympathetic nervous system may be directly concerned with the postural activity of skeletal muscle.

The higher parts of the central nervous system—the labyrinth, the cerebellum and the cerebral cortex—have a profound influence on postural activity.

It is suggested that in many cases postural deformity originates as a functional nervous disorder, and that the cause is to be sought in the mental rather than the physical condition of the patient. Attention is drawn to the frequent association of postural deformity with neurasthenia and with a neuropathic family history.

There is a close relationship between the postural activity of skeletal muscle and the vascular reflexes which determine the blood supply, and therefore the nutrition of all functioning tissues, and it is suggested that herein may lie the explanation of the bony changes which occur in postural deformities.

Among postural deformities are included cases of scoliosis, kyphosis, flat-foot, coxa vara, genu valgum, and possibly others—all arising from the same common etiological factor: deficient postural activity in the upright position.

Memoranda:

MEDICAL, SURGICAL, OBSTETRICAL.

DIFFERENTIAL STAINING OF CARCINOMATA.

Writing subject to correction, I have not hitherto noted any record of a histological staining method which enables one to pick out scattered carcinoma cells in sections illustrating very early secondary glandular invasion. It is obviously of first importance to be able to identify early carcinoma histologically, whether primary or secondary, and it is often extremely difficult to ascertain early glandular invasion where there are only discrete or scattered groups of two or three carcinoma cells in the section. The ordinary methods, such as haematoxylin and eosin, fail signally in such cases, the cancer cells being usually indistinguishable from the closely packed leucocytes in such sections. If, however, the section (not thicker than 0.08 mm.) is stained for ten minutes at 37° C. with Mayer's haemalum (British Drug Houses), washed in several changes of tap water and counterstained with Van Gieson's stain (Strangeways's formula) for fifteen seconds, and then dehydrated, cleared and mounted in balsam, it is quite easy to pick out the carcinoma cells individually or grouped in early glandular invasion, for they stain characteristically. The cytoplasm stains a dirty light brown colour and the nucleus a much lighter violet than that of the nuclei of the gland cells proper. The contour of the cell is typical and the eccentricity of the nucleus also aids one, but the point I wish to emphasize as so characteristic is the colour and prominence of the cytoplasm, especially with natural illumination.

If a gland with advanced invasion be cut it will be seen that the cells I have described partake of the same features as those of the growth masses. A little practice enables one to pick out carcinoma cells with ease and comfort. It is hardly necessary to add that the method is of as great or greater value in very early primary growths.

I have found this method invaluable since I first used it, some two years ago, and I surmise that this record will be of interest to fellow workers.

A. GEOFFREY SHERA, M.D. Cantab.,

Pathologist, Princess Alice Memorial; Eye and Ear Hospitals, Eastbourne; late Pathologist, B.R.C.H., Netley.

Eastbourne.

AN OPERATION FOR RETROFLEXION OF THE UTERUS.

It seems to me that the varied operations on the round ligament which have for their object the cure of persistent retroflexion of the uterus are all open to question with regard to their efficiency. With this idea I have devised

the following method, which, so far as I am aware, has not been described before:

The abdomen is opened just above the pubes a little on either side of the mid-line. At a point on the external surface of the abdominal wall, about two inches from the edge of the wound and a little above the pubes, a ligature carrier of forceps pattern armed with stout silk is made to penetrate. When through the wall the blades are separated a little to widen slightly the aperture made; the carrier is then passed around the round ligament about an inch and a quarter from the uterus. Both ends of the silk are now grasped by the carrier and withdrawn through the aperture at which they entered, taking the silk, which being pulled upon brings out a loop of round ligament. This manoeuvre is repeated on the other side. The uterus will now be found to occupy the normal position. The next step is to dissect up a strip of the aponeurosis parallel with its fibres and at the edge of the aperture made; this strip should be about a quarter of an inch wide and of sufficient length to be passed easily under the loop of round ligament and stitched back in its bed with interrupted sutures. The round ligament is not stripped of its peritoneal covering, which will now line a new canal for the ligament to play in with the movements of the body. The abdomen is closed in the usual way.

With this method the entire length of the ligament is still of use if ever the uterus becomes pregnant. There is no chance of its giving way, and, owing to its proximity to the uterus, its support is permanently maintained. I visited to-day a multipara upon whom I performed this operation in the Gisborne Hospital six months ago, and without any prompting she said: "I have never been so well for years; I do not know myself; I am never irritable." Dr. Bowie, of this town, has since told me that he has performed this operation on four cases with complete success.

JOHN CRAIG, F.R.C.S.I.,

Gisborne, New Zealand. Consulting Surgeon, Gisborne Hospital.

DISLOCATION OF THE RADIUS FORWARDS AT THE INFERIOR RADIO-ULNAR JOINT.

ANTERIOR dislocation of the radius at this joint is perhaps of sufficiently rare occurrence to warrant description of a case, particularly as the lesion was produced as a result of a "back fire" when "cranking up" a car, and therefore constitutes one of the many so-called chauffeur's injuries.

The patient, aged 39, complained of pain in the right wrist from having previously received a blow from the starting handle of his car. When seen there was much swelling round the wrist-joint, tenderness on palpation, and pain on movement. In addition to some ligamentous tearing being present, a fractured carpal bone was suspected, and a skiagram was obtained which revealed a forward dislocation of the radius at its ulnar articulation. No evidence of any fracture in the carpus was apparent, and the wrist was carried forwards on the radius. The triangular fibro-cartilage had obviously been loosened and probably some of the lower fibres of the interosseous membrane were torn, in addition to the anterior and posterior inferior radio-ulnar ligaments. Reduction was not difficult, and full pronation was maintained with the wrist dorsiflexed.

It is now six weeks since the accident occurred, and there is full movement at the wrist-joint, with no undue laxity of the inferior radio-ulnar articulation.

I am indebted to Mr. John Murray for giving an opinion on this case.

LAMBERT ROGERS, M.R.C.S.,
House-surgeon, Middlesex Hospital.

PREVENTION OF INTESTINAL OBSTRUCTION AFTER VENTROFIXATION.

MR. ALEXANDER DON, of Aberdeen, in his article on the prevention of intestinal obstruction after ventrofixation (April 16th, 1921, p. 563), recommends stitching the bladder and peritoneum above to the anterior surface of the uterus after reflexion of a corresponding peritoneal covering of the uterus, thus obliterating the space between uterus and bladder below the fixation stitches.

For years I have simply used a continuous suture to unite the two peritoneal surfaces, uterus and bladder, beginning at the reflexion between uterus and bladder and stitching up to the fixation stitches. The peritoneum is in this position fairly loose, and at the reflexion easily picked up by a pair of forceps. This completely obliterates the space. A number of pregnancies which have followed have been quite normal, as have also the labours, the last woman being delivered before either the nurse or the doctor arrived. There has never been any obstruction, to my knowledge, in any of the cases.

Nelson, Lancs.

R. STEWART, L.R.C.P. and S., D.P.H.

Reports of Societies.

TREATMENT OF LEPROSY AND TUBERCULOSIS WITH SODIUM GYNOCARDATE.

IN the Section of Tuberculosis and Pharmacology of the Royal Society of Medicine, on April 19th, Sir LEONARD ROGERS read a paper, detailing in large part experiences in India, on "The treatment of leprosy and tuberculosis with sodium gynocardate." This substance given subcutaneously, he said, had proved painful and slow in action, and therefore its injection intravenously had been tried, and the results were good. It was given in very slight doses (1/5 c.cm. of a 3 per cent. solution), and severe reactions customarily followed, after which the leprosy lesions tended to clear up. In one patient, an Indian of very high position, who had suffered from leprosy for twenty years, and had enormous thickening of parts of the face, the very minute dose given intravenously brought on a reaction which lasted for a month, and in the course of a year the whole of the thickened nodules disappeared, and altogether the patient showed the most remarkable improvement the speaker had ever witnessed in a case of such long duration. In another case an enormous lesion of the nose began to shrink after treatment and cleared up, a slight pitting only remaining. Attention was then turned to other substances, partly with a view to tackling the acid-fast bacillus of tuberculosis; in this condition, for fear of producing a generalized tuberculosis, he did not feel justified in using sodium gynocardate intravenously. The fatty acids of cod-liver oil were separated out and sodium morrhuate obtained, and experiments were also made with linseed oil (which yielded a product very irritating to the tissues), Japanese sardine oil (which was very toxic), and soya-bean oil (which gave rise to a product quite painless on injection and not toxic). Out of 51 leprosy cases treated with sodium gynocardate, one—the worst case he had ever seen—showed no improvement, 9 showed slight improvement, 20 very great improvement, and 21 complete disappearance of the lesions, with a bacteriologically negative result. With sodium morrhuate, out of 20 cases, 3 showed slight improvement, 12 very great improvement, and 5 the disappearance of the lesions. He made a later investigation, after the lapse of another year, on the earlier cases which had been treated with sodium gynocardate, and found that these traced had remained well or showed further improvement, save in 5 cases which had relapsed. In passing, he mentioned that he had worked out some figures which showed that leprosy had its beginning mainly in the first two decades of life; in 65 per cent. of the cases the original infection must have started before the age of 20. The same liability to infection in early life characterized tuberculosis.

The work on tuberculosis had not gone very far. He and five other medical men in India had tried sodium morrhuate in tuberculous lesions, and five of the six after a year got results showing definite improvement. One experienced civil surgeon had treated 18 cases of tuberculous glands of the neck, and in every case had brought about their disappearance, though in one case there was relapse. The speaker had treated one case of lupus with a new preparation—mercury morrhuate—rubbed in locally, and the case cleared up, and three similar cases by other observers were reported. The treatment promised better for chronic local tuberculosis than for pulmonary tuberculosis. Sodium gynocardate had been shown by some workers to have an action on acid-fast bacilli and sodium morrhuate to have no action, but even if sodium morrhuate had no action *in vitro*, undoubtedly in the human body it induced febrile reactions with breaking down of the bacillus. He thought that the success attending sodium morrhuate in lupus was hopeful, but he would not advise its use in pulmonary tuberculosis except by experts under carefully controlled conditions.

Dr. SHAW MACKENZIE suggested that lipoids would be of considerable use, and in tuberculosis preparations of the bacillus itself should yield fruitful results.

Sir LEONARD ROGERS replied that he had not used lipoids; he had all along preferred to use something foreign to the tissues—a substance not normally present in them—to one which could be isolated therefrom.

Kaolin in the Treatment of Cholera.

Dr. R. R. WALKER read a paper on "The action and uses of kaolin in the treatment of Asiatic cholera." He said that when hypertonic saline—as recommended by Sir Leonard Rogers—was used, the mortality was 22 per cent., and convalescents were discharged on the eighth day. With kaolin and hypertonic saline, the mortality was 29 per cent., and convalescents were discharged on the sixth day. In all the cases rectal lavage with kaolin solution was carried out. He found the combined treatment with kaolin and hypertonic saline was not as successful as that with kaolin alone. The latter brought about calm sleep, early cessation of the suppression of urine, and absence of relapses. He detailed the bacteriological and chemical researches he had undertaken, and demonstrated that the lethal alkaline fluid which resulted from the activity of the vibrio was rendered innocuous by mixture with kaolin. He expressed a wish that the substance should be tried in typhoid.

Sir LEONARD ROGERS pointed out that in order to get reliable statistics cases should be taken uniformly through a whole epidemic, as it was well known that towards the end of an outbreak the mortality was only half what it was at the beginning. With the hypertonic saline treatment he had had 20 cases without a death, but following such a series he might have one or two fatalities. He said it would be interesting to test the effect of injecting the toxic fluid and the kaolin together, for such a mixture would approximate to the conditions in the intestine when kaolin was injected. He agreed that the treatment now set out was worthy of further trial.

PLAGUE ON SHIPBOARD.

At the meeting of the Section of Epidemiology and State Medicine of the Royal Society of Medicine held on April 10th, Dr. W. M. WILLOUGHBY, medical officer of the Port of London, read a paper on plague on shipboard. His chief point was to indicate the danger of the storeroom and its vicinity in relation to the origin and spread of plague from rat infection. He analysed the conditions obtaining in eight ships which, during the period 1917–20, came into the Port of London with cases of plague on board. In these eight ships, with a total complement of 1,715 persons, there were thirty-nine cases of plague. In five of the eight outbreaks the first person to be attacked was the storekeeper, and in three of these five the assistant storekeeper was also attacked. In other cases lascars, who were the first to be attacked, had been concerned with the issue of stores. Dr. Willoughby showed plans of the ships, indicating the position of the storeroom in relation to the berth of the men infected, and also the situation of the lavatory, which was an important consideration, because, if there was rat infection on board, the vicinity of the water supply was always a danger zone. Every hold of one of the ships contained rats which had died of plague, but the storeroom was the only focus of the human infection. It was possible for rat infection to exist for a long time without giving rise to human infection until some disturbance of the rat community took place. The first case of human plague occurred on one of the ships thirty-five days after leaving Bombay; this ship had called at Marseilles, where it was fumigated, and the human infection occurred subsequently. The rat infection had probably been simmering in the hold for weeks, but the fumigation, by interfering with the rats, precipitated the human infection. It was very important while fumigation of a ship was in progress that an effective rat hunt should be instituted on deck. By searching with canes in every possible recess he had caused to be captured nearly fifty rats on the deck of a ship after all the holds had been closed up. The disturbance of infected rats by cargo discharge was similarly dangerous, first to the ship's complement and then to the people at the port of discharge. In examining the history of any occurrence of plague on shipboard it was not sufficient to take into account the homeward voyage only, but the outward voyage should also be borne in mind, and perhaps even the previous voyage. The number of rats appeared to have no particular relation to the extent of the outbreak. The known rat history of one of the infected vessels only included 28 rats; in other cases, where the infection was no greater, the rats were numbered by the hundred.

In the course of a brief discussion, Dr. W. D. BETENSON, assistant medical officer of the Port of London, said that the cat history of one or two of the infected vessels was interesting. More than one of the animals—who were the pets of the storekeeper—had glandular swellings of the neck, but on the cats being killed, bacteriologists failed to find plague, although there were suspicious signs; it was a question whether cats, and also dogs, had not a certain degree of immunity which defeated the bacteriologist.

Dr. WILLOUGHBY, in replying on the discussion, gave some account of the steps taken in the Port of London to deal with suspected ships or ships from an infected port. Every parcel or box as it went over the side was watched, and if it was a well-packed bale or an unholed box, which could contain no rat, it went on to its destination. But more difficult cargo, such as feathers, was put in a rat-proof storehouse for fourteen days. The passengers went ashore under a system of surveillance, whereby every name and address was taken and a notification sent to the medical officer of health for the district in which they intended to reside. In 85 per cent. of the cases the addresses so given were trustworthy. Answering another question, he said that in the tideway of the Thames, if a ship was four hundred yards out, a rat could have small chance of swimming ashore, but in slack water the case was different, and there a matter of another hundred yards might be important.

THE BLOOD GROUP IN MOTHER AND CHILD.

A MEETING of the Pathological Section of the Liverpool Medical Institution was held on April 14th, with the President, Dr. J. E. GEMMELL, in the chair, when Dr. FRANCIS B. CHAVASSE read a paper on "The blood group in infants and their mothers." He stated that a series of experiments upon this subject in the summer of 1919 showed that the blood group was determinable at birth by macroscopic test of the infant blood against stock serums. The incidence of the four blood groups in the newly born was identical with their incidence in adults. The rapid macroscopic test for the blood group yielded incidences of the various groups which were identical with the incidences obtained by more complicated methods; it might therefore be regarded as an accurate test (both for adults and infants). The blood group of the infant frequently differed from that of its mother, and twins might differ in this respect both from each other and from the mother. Where by reason of a difference in the blood group a condition which might be termed "maternal threat" to the child arose, the child's blood was invariably agglutinated by the serum of its own mother. But while the agglutinophilic receptors of the infant's corpuscles were thus invariably present at birth and enabled the blood group to be identified, the agglutinins themselves which were appropriate to the group thus identified were fully developed at birth in about 30 per cent. of cases, so that in cases of "foetal threat" to the mother the infant's serum agglutinated the blood of the mother (and of the other individuals of the mother's group) in 30 per cent. of such cases only. There was no obvious relationship between maternal threat and sterility or between foetal threat and eclampsia and the toxæmias of pregnancy. The fact, however, that agglutination *in vitro* was invariable in the former case and common in the latter showed that no immunity was acquired, the protective mechanism *in vivo* being referable therefore to the fact that dialysis of agglutinins via the placenta was not permitted by the intervening cells, at all events during life. The incidence of the blood group in lying-in women was identical with the normal adult incidence, nor was there any relation between the relative blood group of mother and child on the one hand and the sex of the child on the other. The transfusion of maternal blood into her infant as performed in cases of melaena neonatorum ought not to take place unless it had been previously demonstrated that both mother and child belonged to the same blood group. If they differed, as they did in one-third of all cases, another donor should be selected. The apparatus (made by Hawkesley) used in these experiments for performing the macroscopic test for the blood group was shown.

Professor E. E. GLYNN gave a demonstration of mechanical apparatus for use in the Wassermann reaction.

CAESAREAN SECTION.

At a meeting of the Royal Medico-Chirurgical Society of Glasgow, on April 1st, Dr. JAMES H. MARTIN made a communication on a series of fifty consecutive Caesarean sections without fatality. Dr. Martin, in describing his technique at length, said it was a modification of that introduced by Professor Murdoch Cameron. His incisions were made about an inch and a half to the right of the middle line, two-thirds being above the level of the umbilicus. This utilization of the rectus and its sheath prevented subsequent hernia. There was the further advantage that as a rule this abdominal incision brought the operator right down on the middle line of the uterus. In making the uterine incision Dr. Martin always used a metal pessary, oval in shape and slightly concave, as suggested by Professor Cameron. In removing the placenta and membranes he turned the uterus inside out. Thus the uterine arteries were kinked and the loss of blood was infinitesimal. The wall of the cavity of the uterus was now rubbed thoroughly with gauze, which might be termed a curettage. The difficulty in removing the membranes in the region of the os was lessened by sweeping the finger round beyond the internal os while the patient was being prepared for operation. In suturing the uterine wound the lowest suture was inserted and tied before the uterus was turned inside-in again, and this seemed to lessen the haemorrhage while the other sutures were being inserted and tied, particularly if the uterine arteries were not well compressed. The sutures were of silk, and interrupted. If the patient was not sterilized, mattress sutures of catgut were usually inserted along the uterine incision, the peritonium and to some degree the superficial muscle being included in these mattress sutures. The peritonium and posterior sheath of the rectus muscle were sutured together with a fine continuous catgut suture, and five or six silkworm gut sutures were inserted through the skin and the anterior sheath of the rectus, but not tied. The anterior sheath of the rectus muscle was now sutured with a continuous catgut suture, and the skin approximated by another similar suture. After cleansing the wound and the surrounding skin, a gauze pad was applied and anchored by tying the five or six silkworm gut sutures referred to above. Gamgee tissue was applied and fixed with six-inch bandages. After the operation the patient was propped up in the sitting posture before being completely out of the anaesthetic. The advantage of this posture was that the lochia when shed flowed through the cervical canal into the vagina, and on to the pad, and was not retained in the uterus. Further, micturition and defaecation were not difficult in this position. With these modifications Dr. Martin had performed fifty consecutive Caesarean sections without fatality to mother or child.

At a meeting of the London Association of the Medical Women's Federation on April 12th, with Lady BARRETT in the chair, Dr. JANE WALKER read a paper on "Tuberculosis in children of school age." She said that great difference of opinion still prevailed as to when tuberculosis was acquired, but most people agreed that it was usually acquired in childhood, though its exact prevalence was still unknown, and percentages of incidence given by different competent authorities varied from 2 in 300 to 15 per cent. Her statistics showed that out of 800 children treated at the East Anglian Sanatorium, 1.5 per cent. gave a history of haemoptysis at the onset, and 20 per cent. a history of cough. A small number dated the onset from an attack of whooping-cough, and a still smaller number from measles. Usually the onset was insidious, with malaise or, more rarely, loss of flesh. The fact that a child came from a home where there was definite tuberculous disease apparently did not make its prospects any worse. Infection by contact appeared to be a far more important factor than infection due to hereditary predisposition. Where tubercle bacilli were present in the sputum the seriousness of the case was enormously increased in children, but the results of treatment in cases where tubercle bacilli did not occur in sputum were very good. Dr. Walker pointed out the importance of training the medical profession in the recognition of early signs of the disease, and suggested that a linking up of hospitals and tuberculosis dispensaries would be of much value to this end. A keen discussion followed

the paper, in which Dr. R. Gordon, Dr. King, Mrs. Hogarth, Dr. Flora Sheppard, Dr. Mary Gordon, and Dr. Parsons took part.

A MEETING of the Manchester Medical Society was held in the Library of the Medical School on April 6th. The President, Dr. GOODFELLOW, was in the chair, and about sixty members were present. Dr. GOODFELLOW gave his presidential address, entitled, "Some aspects of preventive medicine." After giving a short historical account of the rise and present position of preventive medicine, he referred to the wide field still open for work in this direction and drew especial attention to the unsatisfactory position in this country of puerperal mortality, and to the need for increased knowledge in subjects such as infant welfare, health during the "pre-school" period, disorders of the heart, and tuberculosis. He emphasized the existing difficulties associated with the supply of pure milk and briefly discussed some methods of dealing therewith. After pointing out the essential factors in the organization of modern methods of preventive medicine, he urged the establishment of greater facilities for post-graduate study and for research work, emphasizing particularly the necessity for a large increase in resident institutional posts. With reference to administrative machinery Dr. Goodfellow put in a strong plea for the establishment of new local health authorities constituted *ad hoc*.

Reviews.

ORTHOPAEDIC SURGERY.

SURGEONS generally, and orthopaedic surgeons in particular, will welcome the publication of *Orthopaedic Surgery of Injuries*,¹ edited by Sir ROBERT JONES. It seems a pity that this very important work could not have been published earlier, for the two volumes comprise a number of articles written by a variety of workers in the special surgical military hospitals, and embody the results of their experience during and since the war. Though injuries resulting from war wounds rather dominate the pages, the accidents common both to the soldier and the civilian are by no means neglected. The influence of the editor's teaching is evident in almost every page, but the writers of the various chapters have been given a free hand to express their personal views. Some overlapping must, we suppose, be inevitable in such a work, but the repetition of general considerations is rather apparent in the earlier chapters.

The first volume opens with an interesting article by Professor Keith on the principles and practice of H. O. Thomas, whose work is rightly considered to have had an immense influence on the later development of orthopaedic surgery. This is followed by a chapter on "Prevention of Deformity," which is sound enough on shock and sepsis as experienced among the recently wounded.

Lieut.-Colonel Joel E. Goldthwait, whose work is so well known in this country, contributes a chapter on the principles of orthopaedic surgery as they apply to the military need. In it he points out how much can be done to increase the number of efficient available for a fighting force by careful attention to posture and the care of the feet in the early stages of a recruit's training.

The bulk of the first volume is devoted to injuries of the bones and joints. Simple fractures are dealt with in an excellent article by Mr. W. H. Trethowan, which, however, would be much improved by illustrations, in which it is entirely lacking. The splinting of war fractures is dealt with by Captain H. G. Carlisle in an extremely well illustrated article. The choice of Mr. E. W. Hey Groves to write the chapter on ununited fractures is particularly happy; in it the causes of delayed union and non-union are fully discussed, as well as the principles involved in the operative treatment of fractures. It is of interest to note that light work is recommended early (five to six weeks) after bone graft operations, provided that the graft has been firmly fixed by splint pins or other metal fastening. Sir Robert Jones's chapter on malunion of the femur is, it need hardly be said, full of sound advice; while Mr. R. C. Elmslie on chronic osteomyelitis is equally sound. Mr.

Naughton Dunn and Mr. S. W. Daw write a thoroughly good chapter on disabilities of joints above the wrist. On the vexed question of the best position for ankylosis of the forearm there is some difference of opinion among the writers in this book. Dunn and Daw recommend the mid-position—that is, midway between full pronation and full supination, with a few degrees of pronation in a clerk's right forearm; later on Sir Robert Jones advises the mid-position, and Mr. W. I. Baldwin (Lieutenant-Colonel U.S.A.), in the next chapter, advises 35 degrees of pronation from the mid-position. The last position would certainly be considered too extreme by most surgeons, whatever their opinions as to the best position. It is apt to be forgotten that many, probably most, men, when seated at an ordinary table in a chair of moderate height, write with the forearm in a position of slight supination. The lower the chair the greater the supination. Moreover, by elevation of the elbow and internal rotation of the arm, lack of pronation can be compensated for, while no contortion can make up for lack of supination.

A carefully written article on the knee-joint is contributed by Mr. S. Alwyn Smith; in it internal derangement of the knee, including injuries of the crucial ligaments, are very fully discussed. Ankylosis and stiff joints generally are dealt with by the master himself, Sir Robert Jones. The chapter is full of useful tips and suggestions drawn from the writer's vast experience, though, as usual, he refers often and generously to the work of others. The same may be said of his chapter on flail joints. Mr. R. C. Elmslie contributes a relatively brief chapter on amputations and artificial limbs, and Sir J. Lynn-Thomas follows with a most interesting account of the centre for the limbless at Cardiff. Dr. F. C. Kidner, an American writer, deals with disturbances of the lumbar spine and pelvic girdle. In this excellent volume the hip is the only joint which does not perhaps receive all the attention it deserves.

The second volume is largely devoted to the injuries of the peripheral nerves. Every possible aspect of the problems involved is adequately dealt with in a series of excellent chapters. The illustrations in this volume are admirable. The anatomy is dealt with by the late Professor A. M. Paterson, diagnosis by Dr. T. Grainger Stewart and Dr. Rowley Bristow, and prognosis by Dr. E. Farquhar Buzzard; Sir Harold Stiles has written a chapter on the operative treatment, which is admirably clear and should be of the greatest service to the young surgeon. The illustrations of this chapter are partly coloured and are reproductions of drawings made during the course of actual operations. Mr. Rowley Bristow gives clear directions as to the post-operative treatment, and also, in a later chapter, details the requirements of an electrical department. The end-results of operations are dealt with by Captain C. Beresford Alexander, of Alder Hey, and Miss M. Forester Brown, M.S., M.D., of Bangour Special Military Hospital.

The problems that arise when all hope of recovery of function after a nerve lesion has been abandoned are discussed by Mr. T. P. McMurray. Opinions differ widely as to the best muscles to select for tendon transplantation—in a case of musculo-spiral paralysis, for instance. It is, however, rather surprising to see that the radial flexor of the wrist, and not the ulnar flexor, is selected for attachment to the long extensor tendon of the thumb. His contention that the thumb and index finger work together and are therefore best moved by the same transplanted muscle, can, for the most part at any rate, be fulfilled by inserting the flexor carpi ulnaris into both—as well as into the tendons to the other fingers—the radial tendon being fixed to the two remaining tendons of the thumb; this plan seems to be preferable when considered with regard to the line of action of the transplanted tendon. He rightly insists on the importance of suturing a transplanted tendon with sufficient tension to avoid leaving any slack to be taken up by the muscle when it contracts, and advises "slight tension." Many surgeons would go further and advise "considerable tension." Most readers will wonder why the next two short chapters, admirable though they are, on injuries of the head and spine respectively, are inserted at all. Written by Dr. E. Farquhar Buzzard and Mr. Percy Sargent, they deal with the diagnosis and treatment rather than with any early or late results which might concern the orthopaedic surgeon.

¹ *Orthopaedic Surgery of Injuries*. By Various Authors. Edited by Sir Robert Jones, K.B.E., C.B., F.R.C.S. London: H. Frowde, and Hodder and Stoughton, 1921. In two volumes. (Roy. 8vo; vol. 1, pp. 555, 266 figures; vol. 2, pp. 700, 268 figures. 44 4s. net two volumes.)

Functional and reflex disabilities, by Drs. Barrows and Morton, and trick movements by Professor F. Wood Jones, are the subjects of the next two articles; both are well illustrated. As many know, Professor Wood Jones, armed with his great knowledge of anatomy, has made a careful study of the muscles a patient may call into action in his efforts to imitate a movement that is normally produced by one or more of his paralysed muscles. He has collected a beautiful set of photographs.

The succeeding chapters deal with splints and plaster (Dr. D. McCrae Aitken), plain metal splints (Mr. R. Lane Joynt), massage (Dr. J. B. Mennell), the Ling system of exercises (Dr. G. Murray Levick), hydrotherapy (Dr. R. F. Fox), and x-ray work (Mr. C. Thurstan Holland). Finally, H.M. King Manuel, who gave so much of his time during the war to the organization and equipment of curative workshops, contributes an article on this subject, while the last chapter is written by Lieut.-Colonel Walter de M. Hill, on the organization and administration of a military orthopaedic hospital.

Some of the chapters in this volume are not, perhaps, quite up to the high standard of the rest, but the few faults to be found do not seriously detract from the excellence of the work as a whole. An enormous amount of useful information is contained in it, and every surgeon will undoubtedly turn to it for guidance in the classes of cases with which it deals. The illustrations on the whole are excellent. The editor and publishers are to be congratulated on the production of an epoch-making work.

THE INSTITUTES OF MEDICINE.

PROFESSOR J. J. R. MACLEOD and his collaborators in their admirable work on *Physiology and Biochemistry in Modern Medicine*² have achieved well-deserved success. It is a great tribute both to the authors and the medical profession that so large and expensive a book should have reached a third edition in the space of three years; it is a most cheering augury for the future.

Although all sections are not equally good and although no one would pretend to be in whole-hearted agreement with every line in the book, it gives a very fair and a very sane account of applied physiology and biochemistry, and it fills the place it was designed to take as "an advanced textbook in physiology for those about to enter upon their clinical instruction." It will be of even greater value as a reference book for those of more mature clinical experience who desire to understand the physiological facts underlying pathological conditions. After all, physiology and biochemistry are the basis of all true medical practice—the interpretation of symptoms as well as the application of therapeutic agents. The study of the heart and the circulation and the factors which influence them is physiology pure and simple. In the laboratory the technique may be difficult and complicated, but the results obtained are more or less readily interpreted and, if necessary, new and drastic lines of experiment may be devised to elucidate the problem. At the bedside the methods available are strictly limited, the investigator is confined to one or two simple lines of experiment, and the interpretation is correspondingly more difficult. Careful and repeated observations on the patient based on sound physiology, such as is given in this book, will greatly help towards the solution of many of the outstanding problems. *Experientia docet*—provided we know what to look for. The modern clinician is, indeed, to be congratulated in having this work as his guide.

The changes made in the present edition are numerous, but they do not essentially alter the character of the book. The section on the nervous system has been recast and rewritten, and the chapters on respiration have been rearranged, the much discussed subject of anoxaemia being dealt with in some detail with special reference to its clinical aspects. Other sections of the book, such as those dealing with the endocrine organs, accessory food substances, ventilation, etc., contain much new matter.

The publishers are again to be congratulated on the get-up of the book.

² *Physiology and Biochemistry in Modern Medicine*. By J. J. R. Macleod, M.B., and others. Third edition. London: H. Kimpton, 1920. (Roy. 8vo, pp. 1024; 243 figures. 42s. net.)

DIATHERMY.

IN *Diathermy, its Production and Uses in Medicine and Surgery*, Dr. CUMBERBATCH, the medical officer in charge of the Electrical Department of St. Bartholomew's Hospital, has produced a volume which traces the history of the subject from the time when the late Dr. Lewis Jones introduced the method into England in 1909. Nagelschmidt demonstrated its use on three surgical cases in St. Bartholomew's Hospital in October, 1910. One of these was a case of enlarged tonsils, in which diathermy was used to remove one and the guillotine the other; the contrast between a bloodless operation and the reverse was striking.

After an introduction and a historical note Dr. Cumberbatch deals, in the first place, with the principles on which high-frequency currents are produced; the next chapter is devoted to a description of various models of diathermy machines. Many diagrams illustrate this portion and make the letterpress clear to the reader. A short but practical note on the care of the apparatus follows. The physiological effects of diathermy are next discussed, with especial reference to arterial blood pressure, the pulse rate and the respiratory exchange. An interesting chapter is that describing some original experiments on the living subject in order to ascertain the effect of diathermy on temperature.

The main portion of the book consists of two parts, the first dealing with the medical, and the second with the surgical applications of diathermy; both are illustrated by photographs of cases before and after treatment, by diagrams of various kinds of electrodes, and by photographs of tissues which have been treated. The methods to be adopted in applying the current for medical purposes are accurately described: the electrodes, their application and situation, the regulation of the strength of the current, and the condenser couch all come under review. Sections follow dealing with the maladies for which this treatment is suitable, and indicating the methods to be used for each condition. Thus sciatica, neuritis, arterio-sclerosis, metatarsalgia, paralysis agitans, and so on, are all dealt with under separate headings. The chapter on the uses of diathermy in surgery commences with a description of the local effects produced by "diathermic coagulation," and a discussion of the actions of different methods of cauterization. The important point is that diathermy raises the temperature of a part till its coagulation occurs *in situ*; the blood and lymph are coagulated and the vessels sealed, whilst infective organisms are destroyed. The essential points of many cases of malignant disease are narrated, and the method employed, dangers to be avoided, and the results obtained, described; cases illustrating the complications which may occur are reported.

The author has produced a book which is a valuable addition to the literature of his subject. It has the advantage of being based almost entirely upon his own work and experience, and sets out very fully the scope of diathermy both in medicine and surgery. Its general construction, the meticulous care for detail, the easy style in which it is written, together with its comprehensive character, should ensure its success as a textbook. Those who practise this treatment should read it carefully, and keep it at hand for reference.

CLINICAL MICROBIOLOGY.

A NEW edition of BEZANON'S⁴ well known work on clinical microbiology will be welcomed by those who desire to improve their bacteriological methods, and especially by those who look to France for guidance and help in such matters. The ingenuity and originality of the French is always refreshing, and those who desire a synopsis of recent developments will not be disappointed in the present book.

As a preface Bezanon reproduces an inaugural lecture given by him in Paris in March, 1919, wherein he outlines the progress of bacteriology during recent years, and traces the stages by which it has developed from the

³ *Diathermy, its Production and Uses in Medicine and Surgery*. By Elkin P. Cumberbatch, M.A., B.M., M.R.C.P. London: William Heinemann (Medical Books), Ltd. 1921. (Demy 8vo, pp. 205; 44 figures. 21s. net.)

⁴ *Précis de Microbiologie Clinique*. By F. Bezanon. Third edition. Paris: Masson et Cie. 1920. (Post 8vo, pp. 931; 7 plates, 200 figures. Limp covers, 30 fr. net; boards, 35 fr. net.)

simple examination of a film or culture, or an animal inoculation, until it has come to touch upon some of the most delicate problems in physiology. He ends by emphasizing the need of constant daily co-operation between physician and bacteriologist in order to interpret the phenomena observed by each.

The book is divided into five portions. Part I deals with the general characters of bacteria, and also includes a synopsis of current knowledge of immunity. Part II is devoted to technique, including the preparation of culture media, special culture methods, methods of isolating bacteria in pure culture, and methods of estimating the various antibodies. In Part III the pathogenic bacteria are described in turn. Part IV is devoted to a description of the bacteria of the normal human body; and Part V deals with the bacteriological analysis of blood, sputum, urine and pus, including the examination of water and air.

The scope of the book is wide, and it is not surprising that the author takes nearly 900 pages to cover the ground. It is practically impossible for one man to maintain a uniform standard of excellence in all the fields here attempted, and perhaps the chief merit of the present work is to be found in the account of particular infections such as sporotrichosis and spirochaetal jaundice, which are both dealt with in considerable detail and with much success. It is surprising to find no reference to the work of the Lister or the Rockefeller observers on the serological types of pneumococcus, to the work of Tulloch on the types of tetanus, or to the apparatus of McIntosh and Fildes for the culture of anaerobes. It would seem that there is considerable scope for someone who will undertake to evangelize the French with regard to British work! But if the present book ignores the contributions of British workers, these can be studied elsewhere. The chief merit of Bezançon's monograph lies in the fact that it is a compendium of current French methods and views on a subject of growing complexity and importance.

MANIC-DEPRESSIVE INSANITY.

The volume entitled *Manic-Depressive Insanity and Paranoia*⁵ is a translation from the eighth German edition of Professor EMIL KRAEPELIN'S *Lehrbuch für Psychiatrie*. Miss MARY BARCLAY, who is responsible for rendering this book into English, has already translated *Dementia Praecox and Paraphrenia*, by the same author, so that the most important clinical publications of the celebrated German psychiatrist are now accessible to the English reader. The conception of manic-depressive insanity as a separate morbid entity has been evolved entirely upon a basis of symptoms and outcome, and Professor Kraepelin is unable to throw any light on the nature of the disease. In view of the great amount of research which has been devoted to this and other forms of mental disorder at the Munich clinic, it is somewhat disconcerting to read that we are still in a state of complete uncertainty as to the meaning and significance of the symptoms they exhibit. In respect to manic-depressive insanity the principal causal factor is to be found in a morbid predisposition, and an hereditary taint was demonstrated in about 80 per cent. of the Heidelberg series of cases.

The description of symptoms and the delineations of the various forms which this disorder assumes alone render this book worthy of the most careful study, but many psychiatrists will be inclined to doubt how far it is justifiable to regard this type of morbid reaction as a definite disease entity. There can be no disputing the fact that this conception is a most convenient clinical generalization in so far as it serves to bring a number of cases with certain symptoms in common under one heading. While, however, the recognition of these symptoms in a given case has undoubtedly a certain prognostic value, so many atypical cases are met with in actual practice that the diagnosis between dementia praecox, manic-depressive insanity and other forms of disorder is often a matter of extreme difficulty. It is almost true to say that if a case gets well we call it manic-depressive insanity, and if not, dementia praecox. Especially is this the case in the hallucinatory and mixed forms of manic-depressive insanity to which Professor Kraepelin devotes so much attention in his book. It

⁵ *Manic-Depressive Insanity and Paranoia*. By Professor Emil Kraepelin, of Munich. Translated by Dr. Mary Barclay, M.A., M.B. Edited by George M. Robertson, M.D., F.R.C.P. Edin. Edinburgh: E. and S. Livingstone. 1921. (Demy 8vo, pp. xv+280; 49 figures. 21s. net.)

is probable that many who read the life-like descriptions of the four forms of disorder included in these two volumes will be inclined to feel that they shade so imperceptibly into one another that no definite boundary lines can be drawn between them. In the future we shall perhaps tend to take a much wider biological, dynamic view of the psychoses, and in this way obtain a much greater insight into and understanding of the significance and meaning of mental disorder. Professor George M. Robertson seems to imply some such view in his brief editorial preface to this volume. We agree with him also when he writes that the medical profession is under a debt of gratitude to Dr. Mary Barclay for her faithful rendering into English of these classical studies.

NOTES ON BOOKS.

WE had occasion not long ago to review the first edition of Dr. GUILLAUME'S work on the sympathetic nervous system.⁶ That a second edition has so soon been called for is sufficient testimony to its interest and value. Much new material has been embodied, particularly in the sections dealing with the morphology and physiology. Fresh chapters deal more completely with the clinical and pathological aspects as well as with diagnosis. A full and excellent bibliography is added. In its enlarged form this book should find a wide circle of readers, constituting as it does a comprehensive survey of a subject which is now attracting so much study and attention.

Under the title of *The Story of the Horton (Co. of London) War Hospital: Epsom*,⁷ Lieut.-Colonel J. R. LORD, C.B.E., M.B., has published an account of the history of the transformation of the civil institution now known as the Horton Mental Hospital into a very different form of activity, which is very interesting, and the immense amount of labour and the fertility of the schemes which it entailed reflect great credit on Dr. Lord and his colleagues. In addition to the general history of the hospital during the war there are chapters giving an account of the detailed work of the special sections of the hospital. In the section on the mental department of the hospital there are some interesting conclusions by Dr. Lord, who, although his time was fully taken up with administration duties as officer commanding, naturally had a considerable interest in war psychiatry. He considers that the war did not occasion any new form of mental disorder, and that in cases of mental breakdown there was probably a predisposition not to all, but to one of the generally recognized forms of mental disease, excluding, of course, definite brain lesions. The form the individual is predisposed to is settled by constitution, conditions of early life—pre- and post-natal—adolescence, early sex and emotional experience, and education. The stress of war would appear to have been more potent in hurrying on mental symptoms, causing them to appear at an earlier stage in the development of the predisposition than ordinary civil causes of mental breakdown would have effected. Dr. Lord must be congratulated not only on the interesting volume which he has produced, but on the valuable work which, in face of many difficulties, he and his hospital achieved during the war.

Of the bound volumes of *Transactions* that have come to us recently for review one is published in this country and two in the United States. The forty-third volume of the *Transactions of the Medical Society of London*⁸ records the scientific proceedings of that Society during its 147th session. The longest contributions are the three Lettsmanian Lectures by Dr. Herbert Spencer "On Tumours Complicating Pregnancy, Labour, and the Puerperium," which were printed a year ago in our own columns; the Annual Oration by Sir D'Arcy Power on "The Rev. John Ward and Medicine"; and the Presidential Address by Mr. V. Warren Low "On Surgery during the War."

The forty-fourth volume of *Transactions of the American Gynecological Society*⁹ is in large part devoted to a

⁶ *Le Sympathique et les Systèmes Associés*. By A. C. Guillaume. Preface by Professor Pierre Marie. Second edition. Paris: Masson et Cie. 1921. (Demy 8vo, pp. 419; 40 figures. 18 francs net.)

⁷ *The Story of the Horton (Co. of London) War Hospital: Epsom*. By Lieut.-Colonel J. R. Lord, C.B.E., M.B. London: W. Heinemann (Medical Books), Ltd. 1920. (Demy 8vo, pp. 264; 7 plates, 1 plan. 12s. 6d. net.)

⁸ *Transactions of the Medical Society of London*. Forty-third volume. Edited by Donald Armeur, C.M.G., F.R.C.S., and William Henry Wilcox, C.B., C.M.G., M.D., F.R.C.P. London: Printed for the Society by Harrison and Sons. 1920. (Demy 8vo, pp. 343; illustrated.)

⁹ *Transactions of the American Gynecological Society*. Volume 44, for the year 1919. Edited by George Gray Ward, jun., M.D. Philadelphia: Wm. J. Dornan. 1919. (Demy 8vo, pp. 427; illustrated.)

record of the proceedings of the annual meeting held in the summer of 1919 at Atlantic City, under the presidency of Dr. Franklin H. Martin of Chicago, whose introductory address on "Gynecology as a Specialty" forms the first item. The discussion on radium treatment of uterine cancer which took place in the previous year at Philadelphia, was resumed by Dr. Harold Bailey of New York, whose paper is freely illustrated. In his conclusions Dr. Bailey stated that "so great has been the palliation from the radium that it may be said that no uterine cancer case receives proper treatment without thorough radiation of the tissues of the pelvis."

The thirty-second volume of *Transactions of the American Pediatric Society*¹⁰ contains the papers read during the annual meeting at Highland Park, Illinois, last summer under the presidency of Dr. Thomas S. Southworth of New York, who in his opening address argued in favour of the segregation of cases of pneumonia. An interesting paper on the food requirements of children, estimated in calories, was contributed by Dr. L. Emmett Holt in conjunction with Miss Helen L. Fales. They maintain that the total daily caloric requirement of children of either sex during adolescence exceeds by nearly 1,000 calories the requirements of the adult man or woman of moderate activity.

Messrs. H. K. Lewis and Co., Ltd., have just published a Supplement (1918-20) to the Catalogue of their Medical and Scientific Library,¹¹ with a list of additions to March, 1921.

¹⁰ *Transactions of the American Pediatric Society*. Volume 32, Thirty-second Session. Edited by Oscar M. Schloss, M.D. (Demy 8vo, pp. 367; illustrated.)

¹¹ *Supplement (1918-20) to the Catalogue of Lewis's Medical and Scientific Circulating Library*. London: H. K. Lewis and Co., Ltd. 1921. (Demy 8vo, pp. 65. 1s. net.)

APPLIANCES AND PREPARATIONS.

A Direct Record Srotometer.

MR. N. BISHOP HARMAN, F.R.C.S. (London), writes: In recent years much attention has been paid to the mapping out of the central fields of vision. The chief difficulties in this kind of perimetry have been due to the slowness of the means of taking the observations, so that the patient got tired, vitiating the results; and, secondly, there was no satisfactory means of making a direct and permanent record of the observations. For the past two years I have been using an instrument which overcomes these difficulties. It consists of a rigid iron stand to which is fitted a frame carrying the screen against which the observations are to be made. The screen is of grey cloth, fixed into it in the central position is a small white metal stud; this is the fixation point. Behind the screen is a sheet of carbon

and a paper chart ruled into the usual degree circles and radii. Red and blue tracing papers are also supplied, which enable three records to be taken, at intervals, on the same chart. The object is carried on a suitable object-holder and held in the surgeon's hand, which is obscured from the patient's view by a grey cloth bag-glove. At the back of the frame knobs are fixed in the usual positions of the blind spots, so that the surgeon has a reliable guide from which to work. In taking observations the patient's face at the naso-buccal groove is pressed against the knob on the free upright of the stand. One eye is covered, the other looks at the fixation spot. The surgeon moves the object over those parts of the field he desires, and notes when the patient sees it and when he does not. The records of the observations are made by pressing the small style on the back of the object holder against the screen, when the impress is conveyed by the carbon sheet to the chart. The whole of the movements of the object over the screen may be traced in this fashion by a light continuous pressure, and salient points marked by deeper pressure. The method is so simple that the surgeon has no need to watch his own movements, so can concentrate his attention on his patient's face and secure that his fixation is constant. The real advantage of this recording instrument is the speed and accuracy with which observations may be made. The instrument has been made for me by Messrs. John Weiss and Son, Ltd., of 287, Oxford Street, London, W.1.



tions the patient's face at the naso-buccal groove is pressed against the knob on the free upright of the stand. One eye is covered, the other looks at the fixation spot. The surgeon moves the object over those parts of the field he desires, and notes when the patient sees it and when he does not. The records of the observations are made by pressing the small style on the back of the object holder against the screen, when the impress is conveyed by the carbon sheet to the chart. The whole of the movements of the object over the screen may be traced in this fashion by a light continuous pressure, and salient points marked by deeper pressure. The method is so simple that the surgeon has no need to watch his own movements, so can concentrate his attention on his patient's face and secure that his fixation is constant. The real advantage of this recording instrument is the speed and accuracy with which observations may be made. The instrument has been made for me by Messrs. John Weiss and Son, Ltd., of 287, Oxford Street, London, W.1.

A Urethral Drainage Bougie.

DR. HENRY DUTHIE (London, W.) writes: The treatment of gonorrhoea, as practised by the Australian medical officers at Codford Camp, was described in the *BRITISH MEDICAL JOURNAL* of March 1st, 1919, p. 245, by Major Forde, M.C. Believing the method to be sound, but crude and painful in its application,

I have had made for me a drainage bougie of the following character. It is simply a tubular mesh of white silk closed at one end, through the centre of which runs a thin vegetable fibre. Its length is about 8 in.; the central core, being several inches longer and being flexible, allows easy insertion. The urethra having been cleared by urination, a sterilized urethroscope tube with a pilot is introduced. The pilot is then with-



drawn and the drainage bougie, saturated with any desired solution, such as permanganate of potash, protargol, acriflavine, is introduced. The urethroscope tube is now withdrawn, leaving the drain *in situ*. Finally, the central core is pulled out, leaving the drainage tube in the urethra. The drain gives no discomfort and is well tolerated. The advantage of this method is that all parts of the mucous lining come into contact with the antiseptic employed, and there is no risk, as in syringing, of driving the pus into the posterior urethra, which I believe is a common cause of cystitis, prostatitis, and orchitis. This method might also be employed for the drainage of small sinuses, fistulae, etc. The silk bougies, and a glass introducer, have been made for me by the Aurorascope Company, Ltd., Fulwood House, Fulwood Place, Holborn, W.C.1.

TUMOUR OF THE BLADDER AMONG WORKERS IN ANILINE FACTORIES.

AMONG the duties imposed on the International Labour Office, set up as part of the organization of the League of Nations, is the protection of the worker against sickness, disease and injury arising out of his employment. In order the better to carry out this duty, a special Industrial Hygiene Department has been formed and placed in the charge of Dr. Carozzi. It has recently produced a report in which a historical account is given of the observations by which a relation was established between the occurrence of tumour of the bladder and work in aniline factories, and the prophylactic precautions which have been taken, seemingly with success, are enumerated.

In 1895 Rehn published three cases of tumour of the bladder in workers in an aniline factory in Frankfort-on-Maine, and since that time a number of similar cases have been reported. The first cases occurred among workers engaged in the preparation of fuchsine and aniline. Inquiries were carried out in a number of factories over a series of years, but no definite conclusions were reached. In 1912 Leuenberger published 18 cases observed among the workers at Basle handling aniline dyes, and a commission was then appointed. The total number of cases reported to it was 177; it is questionable whether some of the cases should have been included. The figures given by Leuenberger of the frequency of this condition in Basle are very striking. From 1901 to 1910 the population of the city included approximately 56,500 male workers, and the number of workers employed in the aniline factories was 840. During that period six workers in aniline dyes died as a result of tumour of the bladder. During the same period there were twelve deaths from the same affection among the rest of the male population. Six cases of tumour of the bladder were observed at the surgical clinic at Basle from 1861 to 1900 before the development of the chemical industry; from 1901 to 1910, after the development of the chemical industry, 16 cases of tumour of the bladder were seen; 10 of these occurred in aniline workers and 2 in dyers.

A large proportion of the tumours noticed have been malignant. They appear especially after the age of 40, and particularly in individuals who have been working in contact with the materials for many years. A large number of products, either singly or in association with others, have been held responsible by various observers. All the suspected products, such as aniline, toluidine, naphthylamine, etc., are amino-compounds. Leuenberger enumerates the following as capable of provoking tumour growths: Safranin, dianisidine, dihydroxyoxiline, Congo red and benzo-purpurine. Benzidine and beta-naphthylamine are considered particularly dangerous.

Experience proves that, while there is no immunity, predisposition plays a great part. There are many factors that favour poisoning—lack of cleanliness, malnutrition, alcoholism, and excesses of every kind. Workers new to the trade, and consequently working without precaution, with whom large skin surfaces come in contact with the

poisonous products, are specially liable. On the other hand, workers remaining a long time in the workshops are more exposed to the danger of introducing by deglutition the products floating in the air. Although the permeability of the skin by the products in question is remarkable, older workers, who take great care of the skin, yield a smaller number of cases of poisoning.

The poisonous products enter the body by various routes—*aniline*, which is volatile, by the respiratory organs; others by the alimentary canal and the skin and mucous membranes. At present it is not possible to say exactly which is the toxic substance that produces the growth of these tumours. The tumours are met with almost anywhere in the bladder, most often on the inferior segment and near the neck. They are said to have been rarely seen below the ureteral orifice. Profuse and dangerous haematuria is a common symptom. Carcinoma is met with, either as a primary tumour infiltrating the bladder wall or as a secondary development following a papilloma. At an early stage the tumours are frequently accompanied by cystitis and nephritis. Lymphatic metastases are found but visceral metastases are uncommon.

The provisional conclusions which the facts are considered to warrant are as follows:

1. There is a close connexion between the manipulation of certain amino-compound products and tumours of the bladder.
2. The number of cases of tumour of the bladder proved to have occurred among workers in contact with amino-compounds is small, and it must therefore be concluded that the individual factor plays a great part in the pathology of the disease.
3. Though no direct relation can be traced between their occurrence and the duration of employment, action of long duration is necessary to produce tumours of the bladder.
4. It is not possible to determine the substance capable of engendering tumours. It can only be said that the amino-compounds, and particularly benzidine and beta-naphthylamine are incriminated.
5. The same substance may produce either simple cystitis or benignant or malignant tumours.
6. Hygienic precautions, strictly applied for a few years, will ensure the diminution and even the disappearance of the disease.
7. It is therefore necessary in factories in which workers are exposed to the action of aromatic bases that hygienic precautions should be rigorously applied.
8. Meanwhile, it is desirable that the industries concerned should continue to carry on researches with a view to ascertaining the dangerous substance, and that the particulars of every case should be precisely recorded by a uniform method.

In the report now before us the importance of early diagnosis by cystoscopic examination is urged. Experience in Germany has shown that repeated cystoscopic examination in suspicious cases is welcomed by the workers when the danger of the disease is pointed out to them.

Kuchenbecker has elaborated a method of examining the urine to demonstrate the presence of amino-compounds; by the periodical examination of the urine of workers dealing with fuchsine, and particularly those preparing benzidine and naphthylamine the presence of the substances named has by this method been traced in large quantities among workers exposed to the inhalation of dust in the factories. The efficacy of the means of prevention adopted has been confirmed by such examination; the quantity of the products in the urine has been observed to diminish and even to disappear after their application.

The precautions taken in certain German factories producing amino-compounds during recent years are believed to have yielded good results. These may be summarized as follows:

Well-ventilated workrooms with extraction of vitiated air and introduction of fresh, and, if necessary, cooled air; rigorous cleanliness of floors and walls; absorption of dust.

Well closed apparatus, including the apparatus for the mechanical transport of materials; local absorption of dusts and vapours.

Reducing working hours; adoption of shifts, in view of the fact that a very short stay in the incriminating section is sufficient to produce tumours.

Working clothes, always strictly clean, closed at the neck and wrists; gloves and shoes.

Daily bath; careful washing before going to the refectory or leaving the factory.

Medical examination of workers, both on engagement and periodically; selection of healthy workers; periodical instruction by the medical officer and director of the section. The periodical examination includes examination of urine as previously indicated.

Compulsory notification of haematuria and tumours of the bladder among workers in factories producing amino-compounds.

Routine cystoscopic examination in cases presenting suspicious symptoms.

In this country regulations have been in force since the end of 1908 laying down the precautions to be observed in the manufacture of certain nitro- and amido-derivatives of benzene and the manufacture of explosives. They apply to dinitrobenzol, dinitrotoluol, trinitrotoluol, paranitrochlorbenzol, aniline oil and aniline hydrochloride. The regulations provide for the extraction of vapour from covered apparatus and for the removal of fumes from rooms by through ventilation by a fan or other efficient means. In crushing materials or filling cartridges with them, an efficient exhaust draught must be so arranged as to carry away the dust as near as possible to the point of origin. An employer must supply suitable overalls, which must be washed every week, or suits of working clothes, a room for changing, another for the storage of overalls, and a messroom. All persons handling the substances are to be supplied with india-rubber gloves, and a suitable scoop must be used in filling cartridges by hand. The workers are required to use the protective appliances, and to clean their hands before partaking of food. Every person employed must be examined by the certifying factory surgeon of the district once a month. The surgeon has power to suspend any person from work. These general regulations are based on the well recognized toxic character of these substances, and the risk of absorption through the skin and subsequent effect on the blood, and though they have no special reference to the prevention of tumour of the bladder are of a nature calculated to attain this end.

Mr. J. F. Dobson, surgeon to the Leeds General Infirmary, has been good enough to make some general inquiries in the North of England, where large dye factories have been established in recent years. At one large factory near Huddersfield the medical man who had had charge of the employees for some years stated that he had seen some cases of haematuria, but had looked upon them as of renal origin; so far as he knew, none of the cases had developed tumour, but none had been examined with the cystoscope. Mr. Dobson, after an examination of the records of the large number of cases of bladder tumour he has seen in recent years, tells us that he is unable to satisfy himself that such tumours occur more frequently in individuals employed in the dye industry than in others; at the same time, of the last two cases he has seen, one was employed in the manufacture of benzol and the other was a dyer. He points out, however, that the workers in the North of England have probably not been exposed to the poisons for a length of time sufficient to produce the lesion, and suggests that Kuchenbecker's test mentioned above might be of use in ascertaining whether the urinary condition is prevalent.

Papilloma of the bladder develops so slowly that the slight initial haematuria would not be regarded seriously either by the worker or the medical man if they were not aware of the danger. The evidence shows that tumours of the bladder due to this cause do not develop until the individual has been exposed to the action of the injurious compounds for many years. The condition can only be diagnosed at a stage when satisfactory treatment is possible if routine examination of cases presenting suspicious symptoms is carried out. This will involve the use of the cystoscope—not an easy instrument to manipulate. Early diagnosis is, Mr. Dobson points out, of extreme importance, for in its early stage papilloma of the bladder can be satisfactorily treated by endovesical diathermy; operation for papilloma gives less satisfactory results. Primary malignant disease of the bladder is very rarely suitable for operative treatment.

A NEW monthly journal, *The Japan Medical World* (Nippon-No-Ikai), has been founded by Dr. S. Tsuchiya in Tokyo, with the assistance of many eminent members of the Japanese profession desirous of making medical progress in Japan better known. The journal, which is written in English, will contain original articles, notes of current Japanese literature, reports of medical societies, and medical news. The annual subscription is 6 dollars, post free. The offices are at No. 10 Omotejinbocho, Kanda, Tokyo.

British Medical Journal.

SATURDAY, APRIL 30TH, 1921.

A CONSTITUTIONAL PROBLEM.

A BODY one of whose two main objects is "to maintain the honour and interests of the medical profession" must find itself periodically under the necessity of modifying its constitution and machinery to meet the needs of the times. The British Medical Association, in its history of nearly ninety years, has never hesitated to make adjustments of this kind even when they entailed considerable departures from custom and tradition. Notably in 1903 radical changes were made in order to create smaller local units and to bring into existence a Representative Body which should be able to ascertain and formulate the desires of a profession organized on modern democratic lines.

The time has come to make possible another step, the necessity for which has arisen from the Empire-wide scope of the Association. Just as British colonies and dependencies have in the course of their growth demanded greater freedom in dealing with their own affairs and have brought about, with the consent and goodwill of the mother country, the necessary changes in their forms of government and their relations with the Home Government, so it has happened with the Branches of the Association in the great Dominions. Gradually, over a period of many years, changes desired by them have been effected by a liberal interpretation of the Articles and By-laws of the Association, and, with very few exceptions, the Central Council has always been able to meet their wishes for greater freedom. The oversea Branches have, in fact, almost unlimited autonomy. But there have been demands which the legal advisers of the Association have ruled could not be met by anything less than a radical revision of the constitution. For example, the right to hold property, to sue and be sued as separate entities, to provide medical defence facilities, and to invest and otherwise deal with money, have been held to be powers that could not legally be exercised by Branches as such. These difficulties can be and have been got over in the oversea communities, as well as in England, by the formation of trusts. That method is still available, but it is an indirect and somewhat cumbersome method. In order that the Branches in Australia, where the problem has arisen most acutely, should understand that no efforts would be spared to meet every legitimate demand on the Association, the Annual Representative Meeting at Cambridge last year approved the proposal that steps should be taken whereby any oversea Branch or collection of Branches feeling such a step to be necessary should be able to leave the Association, form themselves into a separate body with all the powers they desired, and affiliate themselves in their new form to the Association. In the consideration of this matter the Council was greatly aided by Dr. W. T. Hayward, C.M.G., formerly and now again Chairman of the Federal Committee of the British Medical Association in Australia, and Dr. H. S. Newland, C.B.E., D.S.O., of Adelaide, both of whom were in this country on military service.

The methods by which this new departure can be brought about were fully described in the SUPPLEMENT to the JOURNAL of March 5th last, and it will be for the Representative Body at Newcastle-upon-Tyne next July to accept or decline the new Articles and By-laws in which the proposals are embodied. They need and deserve the careful study of every member of the Association interested in the evolution of its constitution. They are, we know, receiving anxious consideration by the oversea Branches specially interested, and we are glad to learn that Australia is sending a special envoy to Newcastle in the person of Dr. R. H. Todd, the Honorary Secretary of the Australian Federal Committee, who has been very prominently concerned in the progress of the Association in Australia for many years. New Zealand is sending Dr. W. Irving of Christchurch to act in a like capacity for that Branch. Both are assured of a hearty welcome. The attitude of the Representative Body will, of course, be influenced greatly by the spokesmen from overseas.

But while the Association at home is making provision for such means of affiliation, it must not be supposed that it looks upon this as anything but a regrettable necessity if, indeed, the oversea Branches should ultimately believe it to be a necessity. We are sure that all the home members would much rather preserve the present relationship if possible. It is for the oversea Branches to decide whether they really need this complete independence. If they can see their way we would much rather have them as Branches of the old Association than as a new Association, with another name, affiliated to the British Medical Association. We would rather have them as brothers than as cousins; but it is for them to decide.

There is another aspect of this question which the Representative Body will be called upon to consider. Is affiliation to be open to other Branches besides those overseas? The question has arisen in Ireland, where there has for some time been a desire on the part of the Branches of the British Medical Association and the Irish Medical Association to fuse themselves into one association which, while composed of both bodies, will be neither, but a new body which, it has been proposed, may affiliate itself to the British Medical Association. If the new Articles and By-laws are carried it would be open to the proposed new body to apply for, and for the Representative Body to receive it in, this new relationship. More than this, the resolutions carried at Cambridge contemplated the possible affiliation of bodies in this country formed to safeguard the interests of special sections of the profession, or even bodies not wholly medical but dealing with the interests of some allied profession. The new Articles and By-laws as set out in the SUPPLEMENT of March 5th make provision for all these developments, and it will be for the Divisions in the next few weeks to decide how widely they wish the door to be thrown open. The conditions on which affiliation is to be offered are to be decided in each particular case by the Representative Body itself. In the Annual Report of Council published in this week's SUPPLEMENT (pp. 105-159), will be found a series of memoranda or rules setting out in skeleton form the kinds of agreement that might be made with any bodies admitted to affiliation. The whole subject is of great difficulty and delicacy: we hope we have said enough to convince members that they should study it thoroughly and make up their minds how far the new proposals are for the good of the Association as a whole, and therefore to be accepted.

PHYSIOLOGY AND CLINICAL MEDICINE IN SHEFFIELD.

THE Panel Committee of Sheffield has given £1,000 to the University of Sheffield to promote the policy of bringing physiology into closer relation with the practice and teaching of clinical medicine. The new departure is interesting from both points of view—that of the University and that of the Panel Committee. The aim of the University authorities and of its medical faculty is to break down the barrier which has been allowed to grow up between physiological and clinical studies. Physiology derives directly from medicine, and it was necessary that the younger discipline should pursue its own way until it had reached a certain standard of accurate and established knowledge. It is apparent by many signs that this stage has been reached. An instance is afforded by recent work in dietetics, and especially as to vitamins, which has yielded important results on the border-line of physiology and pathology.

It will be remembered that a short time ago Dr. Edward Mellanby, a physiologist who had recently given much attention to vitamins, especially in connexion with rickets, was appointed professor of pharmacology in the University of Sheffield. At the same time the board of the Royal Infirmary, in order that the new professor and his department might not be divorced from clinical work, appointed him to a vacant post of honorary physician to that great teaching hospital. In pursuance of this policy of securing for the patients of the infirmary and the students of the medical faculty the benefits of expert physiological advice and teaching, the Board, with the consent of the University, also appointed Professor J. B. Leathes, M.B., F.R.S., the present incumbent of the chair of physiology, to be consultant physiologist to the Infirmary. Another development of the same policy is seen in the appointment, through a joint arrangement with the Royal Hospital and with the approval of the University, of Dr. Imrie to be full-time clinical physiologist to both hospitals. Dr. Imrie had previously been deputy professor of biochemistry at Toronto.

These appointments have vastly strengthened the medical work in the city, both on the educational and technical side, and by the generous assistance they have given to the Department of Pharmacology and its field laboratory the panel practitioners of Sheffield have not only afforded most valuable support to the University of their city but are helping research work which promises to yield fruitful results in therapeutics; it will be interesting to explain how it has come about that they are in a position to do so.

By the exercise of strict economy and the use of the voluntary labour of its members during the war years, the Panel Committee was able to save from its funds enough money to invest £1,000 in War Loan. It was felt at the time by the Committee that it was very necessary to have some accumulated funds for use in any acute emergency which might arise, and the fact that the Sheffield Panel Committee was financed by a purely voluntary scheme rendered this possible. When the financial situation was reviewed at the beginning of this year, it was seen that the economies had resulted in a considerable surplus; so much so that the voluntary levy could be suspended for at least six months, and that a sum of about £1,000 could be disposed of. The matter was fully considered at several meetings of the Panel Committee, and legal opinion was taken. Finally a meeting of practitioners on the panel was called, and at it a resolution was passed directing that War Stock to the amount

mentioned should be transferred to the University with a request that it should be earmarked for the equipment of a Field Research Laboratory in the Department of Pharmacology under Professor Mellanby. This has now been done.

Professor Mellanby's department will consist of a laboratory at the University, and of a fully equipped field laboratory for experimental work, on the lines of his field laboratory at Cambridge, which many members visited during the Annual Meeting last year. Professor Mellanby's work on rickets in relation to fats and vitamins has, as is well known, revealed many hitherto unsuspected aspects of this vexed problem; whilst Mrs. Mellanby's brilliant proof that the problem of dental caries is largely a matter of biochemistry, rather than of mechanics or bacteriology, is closely related to her husband's work. Professor Mellanby's association with clinical medicine has already produced some other results which promise to bear valuable fruit, for we are told that, in a preliminary communication recently made to the Physiological Society, he was able to announce that if patients with Graves's disease were put on to a relatively low diet, almost free from fat, with small doses of cod-liver oil and potassium iodide, they gained weight rapidly and the symptoms were ameliorated.

The action of the Sheffield Panel Committee may help the public to an understanding of the medical point of view, about which there is a good deal of misapprehension. The representatives of Approved Societies too often seem to believe that the medical profession is always thinking of schemes to get higher rates of pay, and medical correspondents of newspapers that it is ready to be the dupe of anyone who with sufficient drum-beating proclaims a new specific remedy for some intractable disease, or alternatively to be superciliously sceptical. The gift to the Pharmacological Department of the University of Sheffield is evidence of the real orientation of medical opinion towards the discovery of fundamental facts as to the functions of the organs of the body, and the causes, prevention and remedy of their disorders.

SECURITY OF TENURE FOR PUBLIC HEALTH OFFICERS.

THE efforts which have been made by the British Medical Association for many years past to obtain security against unfair dismissal are at length bearing fruit. After a deputation to the Government in June, 1914, a promise was made by the then President of the Local Government Board, Mr. Herbert Samuel, that if it proved within its power to do so the Board would make an Order giving security of tenure to whole-time medical officers of health and inspectors of nuisances. The issuing of this Order was deferred owing to the disorganization of the medical services of local authorities due to the war, but in May, 1920, Dr. Addison, upon being reminded of Mr. Samuel's promise, stated that he would have the Order proceeded with, and would go as far as he could in giving security to whole-time medical officers of health and inspectors of nuisances. The Order, dated April 12th, 1921, has now been issued. It applies to whole-time medical officers of health and sanitary inspectors (inspectors of nuisances) appointed by the council of a county borough or county district, or by a port sanitary authority. The council of a county district includes a municipal corporation or an urban or rural district council. Appointments of these officials made after May 1st next will be without limit of time, after a probationary period of twelve months, at the expiration of which the appointment must be confirmed by the Minister of Health. The definition of a whole-time officer is one who is required by the terms

of his appointment to devote the whole of his time to the duties of his office or of any other office or offices held by him under any local or other public authority. The effect of the Order is that all whole-time medical officers of health will have security of tenure, except those appointed before May 1st, 1921. In order to put them in the same position as their colleagues, Sir Philip Magnus, at the instigation of the Association, introduced the Public Health (Officers) Bill in the House of Commons on April 12th, and he had the good fortune to secure its second reading on April 14th.

THE UNIVERSITY OF BRISTOL.

THE University of Bristol, like most of the other English universities, is making a public appeal for general endowment—a course it is well entitled to take in view of the substantial support the University is receiving from local education authorities in the West of England. In explaining recently the grounds of the appeal, the Vice-Chancellor, Sir Isambard Owen, D.C.L., M.D., made it plain that the needs of the Faculty of Medicine are to be accorded a distinctive place in it, the endowment of professorships in the faculty being put forward as an urgent matter. The Bristol Medical School, now incorporated in the University, has a long and honourable history, illustrated by many distinguished names; and under the aegis of the University (founded in 1909) has achieved a reputation which we hope will make a powerful appeal to the public spirit and generosity of the West of England. The number of medical students in Bristol is at present 155, and the faculty includes also a flourishing school of dental surgery, with 75 students.

SECRET REMEDIES AND THE GERMAN MEDICAL PRESS.

It would appear that the sale of quack remedies has greatly increased in Germany under the new order, and many bitter things are said in the medical journals about democracy in its relation to the control of unqualified practitioners and their remedies. Three periods during which the fortunes of the quack oscillated violently can, it is said, be distinguished. In the first, the pre-war period, there was a neck-and-neck race between the enterprising quack and the paternal Government, which, by new regulations, was constantly heading off new devices for exploiting the credulous. At one stage in this period it was calculated that of seventy-five secret remedies analysed, as many as forty-eight were directly dangerous to life, and another eleven were calculated to be injurious. In the year 1898-99, the turnover of secret remedies in Germany amounted to 30 million marks, and 500,000 kilograms of secret remedies were imported yearly.¹ In the second period, which corresponds with the great war, the lot of the vendor of quack remedies was hard. Though he might attempt to distribute his goods among the troops as mere or less authorized gifts from Hindenburg or Zeppelin, his campaign was seen cut short by the military authorities, whose regulations ultimately became very stringent. The third, or post-war period, would seem to have afforded brilliant openings for nimble-witted adventurers, who have found in the sudden political change unrivalled opportunities for avoiding punishment. Recently a circular signed by Professors Heffter, Klemperer, Lennhoff, and Schwalbe, and the chairman, Dr. Herzau, has been addressed by the Association of the German Medical Press to the editors of medical periodicals, pointing out that the impudence of advertisements of all kinds of quack remedies is increasing, and asking the editors that they should arrange with the publishers to have a controlling share in the acceptance or refusal of advertisements, if they already do not possess such power. The manifesto recommends that only such advertisements of remedies should be accepted as state the

composition of the remedy, and that advertisements should on principle be refused which appear in the daily press and in form and matter are bombastic, extravagant, untrue, or misleading.

ACUTE BENIGN LYMPHOBLASTOSIS.

DISEASES of the lymphatic glands present a number of problems awaiting solution, and among these the influence of acute adenitis on the blood picture is of considerable interest. The tendency of glandular inflammation and irritation to produce a lymphocytosis is fully recognized, but the degree of this reaction may vary considerably, and in some instances the blood count may strongly suggest acute lymphoid leukaemia, and indeed doubt as to the correctness of this diagnosis may only arise when the patient recovers. In glandular fever, originally described in 1889 and lately rather forgotten, though Drs. H. L. Tidy and Morley recently gave a full clinical account of it in our columns,² there are very few blood counts available, but in some examples of acute lymphadenitis the diagnosis from acute lymphoid leukaemia in an early leukaemic stage—that is, with little increase in the total white count—may cause much anxiety. Thus T. P. Sprunt and F. A. Evans recently described, under the name of infectious mononucleosis, a fairly definite group of 6 cases with fever, enlarged glands, a leucocytosis up to 20,000 per c.mm., a slight increase in the large mononuclear-transitional cells, and many pathological lymphoid forms.³ A very similar, if not identical, series of cases has just been recorded by W. A. Bloodorn and J. E. Houghton⁴ at the United States Naval Hospital, Annapolis, Maryland, as acute benign lymphoblastosis: all the four patients were young adults and showed febrile enlargement of the lymphatic glands, particularly the cervical and submaxillary, and sometimes of the spleen, usually after infection of the tonsils or upper respiratory tract; leucocytosis was not constant, but the striking change was a mononuclear increase with lymphoblasts predominating, and often the presence of cells with the clover-leaf or bilobed Rieder nucleus. Three out of the four cases showed Vincent's organisms in throat smears taken during the acute phase, but examination of several cases of Vincent's angina proved that lymphoblasts are not a common feature in this form of infection. All the patients recovered, but the differentiation of this condition from acute lymphoid leukaemia may be very difficult; the absence of degenerated and fragile cells in the blood smears, the early fall of temperature, the mild course, and the absence of haemorrhages and of high leucocyte counts, are the distinguishing features.

EFFECTS OF CARBON MONOXIDE ON THE EYE.

THE effects of carbon monoxide upon the eye, about which very little can be found in the textbooks of ophthalmology, form the basis of an interesting paper by W. H. Wilmer of Washington in the *American Journal of Ophthalmology* for February, 1921. He gives a general survey of the subject and deals with the nutritional effects of carbon monoxide poisoning, as well as the eye complications. The paper reads like a ghost story in places, and certainly throws light on the question of haunted houses. Wilmer gives the notes of two cases: in the first a whole family was subjected to the slow poisonous effects of the gas fumes escaping from a faultily constructed furnace into the house instead of going up the chimney; the member of the family who suffered most was a small boy aged 4 years. The general symptoms were noticed by all members of the household, and consisted in listlessness, delusions, and hallucinations. Wilmer saw the little boy some four years after he had been taken from the poisoned house; his general health had been much upset, he was anaemic, and suffered from gastro-

¹ BRITISH MEDICAL JOURNAL, 1921, i, p. 450.

² *Ibid.*, 1921, i, 95.

³ W. A. Bloodorn and J. E. Houghton: *Arch. Int. Med.*, Chicago 1921, xxvii, 315-325.

⁴ *Deut. med. Woch.*, January 20th, 1921.

disturbances; though intelligent for his age, he was slow in reading. The chief change found was a contraction of the visual fields. The fundus did not present any obvious abnormality, but the disc is stated to have been high-coloured; charts of the fields of vision taken at this time show a general contraction down to within 20 degrees of the fixation point. As time went by this contraction for white gradually improved, and after two years the field for white was shown to be very nearly full, but an enlargement of the blind spot and a large paracentral scotoma remained. The second case occurred in a man, aged 35, who was at work in a closed room removing paint from a mantelpiece by means of a gasolene torch. After about two hours' work faintness, giddiness, nausea, and headache came on, but quickly disappeared on ceasing work, when he noticed some mistiness of sight. On resuming work a similar train of symptoms occurred, but the visual defect, which had quickly cleared up after the first bout, now persisted. The man saw several oculists, who diagnosed optic atrophy; the fields show a slight general contraction for white, and it is stated that the colour sense is defective, while central vision is reduced. We agree with the author as to the importance of having household furnaces of this kind, as well as all gas fixtures, properly inspected in order to obviate such domestic calamities; in Wilmer's first case it appears that the small boy was not far off the point of death when he was taken from the poisoned house. It would be well to bear this cause in mind when dealing with unexplained cases of optic atrophy.

BILHARZIASIS AND ITS TREATMENT.

At the annual meeting of the British Medical Association at Cambridge last year Dr. P. Manson-Bahr, as reported in the *JOURNAL* on August 14th, p. 235, related some encouraging experiences he had had in the treatment of human trypanosomiasis and kala-azar by intravenous injections of the acetyl-para-aminophenyl stibiate of soda, called for convenience "stibenyl" by the manufacturers, Messrs. Allen and Hanburys. It contains 34.3 per cent. of antimony. He found, however, that this preparation was of no value in bilharziasis, and a patient on whom it had no effect was cured of the disease after 16 grains of tartar emetic. The toxicity of tartar emetic is a great disadvantage, as extremely small doses only can be tolerated by man, and the treatment is necessarily protracted. Dr. F. G. Cawston, of Durban, who for some considerable time has been carrying on researches into the treatment of bilharziasis and allied conditions, has therefore sought to obtain a therapeutic agent of less toxicity than tartar emetic, for which purpose he received last year a grant from the British Medical Association on the advice of the Science Committee. Articles by Dr. Cawston have been published in our columns (November 20th, 1915; July 29th, 1916) in which he stated that the best treatment of bilharziasis at that time was by means of diuretics and urinary antiseptics; hexamine, which is a slight diuretic as well as a powerful urinary antiseptic, being considered the most valuable. He pointed out also that too much reliance should not be placed on remedies that had been recommended as cures unless microscopical examination of the urine of the persons said to have been cured had been made. We have now received a communication from Dr. Cawston containing the results of his tests of the efficacy in the treatment of bilharziasis of two new and untried preparations of antimony, which like stibenyl have been made by Messrs. Allen and Hanburys—acetyl para-phenylene diamine antimony tartrate (antimony 26 per cent.) and para-phenylene diamine antimony tartrate (antimony 28 per cent.). Dr. A. Wallace, of Broken Hill, tested for Dr. Cawston the effect of stibenyl on a case of trypanosomiasis, but did not consider that it acted so well as tartar emetic, so, in view of the opinion also of Dr. Manson-Bahr, Dr. Cawston did not test that

preparation on bilharziasis. The other two preparations he did not find less toxic than an equivalent quantity of potassium tartrate of antimony (tartar emetic), but the first of the two was in one case at least effective in curing bilharzia disease of long standing. As antimonyl sodium tartrate is definitely less toxic than either of the two preparations, and is apparently equally effective, Dr. Cawston does not consider there is any advantage in employing the new preparations of antimony on further cases of bilharziasis in South Africa.

MIDHURST SANATORIUM.

THE report for 1920 of the King Edward VII Sanatorium, Midhurst, of which Dr. H. O. Blanford is superintendent, contains many points of interest. Treatment by graduated labour, combined with adequate rest, was more systematized during the year, the work being carried out in the grounds and gardens of the institution; the treatment had a good effect both on the physical and mental conditions of the patients. In April, 1920, an x-ray department was opened, which has already proved of great assistance in the diagnosis of indefinite cases. In the pathological laboratory, which was reopened after having been closed during the war, a considerable amount of research work has been carried out. The routine examinations of sputum has been modified to some extent; positive cases are examined less frequently, and more attention is being devoted to repeated examinations of negative cases. This procedure was adopted owing to the fact that a considerable number of negative tests were found to be requisite to justify the presumption that tubercle bacilli were no longer present. In most of the positive cases the bacilli were usually easily found, but repeated examinations were necessary in some cases before their presence could be demonstrated. Up to the present both sedimentation methods and guinea-pig inoculation have proved negative in cases in which tubercle bacilli were not found after repeated careful examination of films stained by the Ziehl-Neelsen method. An investigation was carried out to ascertain whether Pfeiffer's bacillus commonly infected the lungs of tuberculous patients, and whether plithisical patients were commonly chronic carriers of the bacillus. In only one case, however, was the impression given that Pfeiffer's bacillus was playing a part different from that of the other apparently innocuous organisms usually found in the respiratory tract. An investigation is being carried out also on the acid-fastness of tubercle bacilli, and it is hoped to establish definite figures as to the acid-fastness of tubercle bacilli which will serve as a basis for comparison of the various decolorizers; they will also serve as a basis for an investigation upon the variability of acid-fastness in different strains of tubercle bacilli found in the sputum. Statistics are given of the 275 cases discharged from the sanatorium during the year, which show the value of the early recognition and treatment of pulmonary tuberculosis. Excluding one patient in whom no definite evidence of disease was found, the condition on discharge was as follows: of 79 slight cases in 50 the disease was arrested, 21 were "much improved," 7 were "improved," and one was "stationary or worse"; of 89 cases in which the disease was more extensive than in the first group, but affected at most the whole of one lobe, the note in 21 was "disease arrested," 51 were "much improved," 15 "improved," and 2 were "stationary or worse"; but of the 106 more severe cases, including all those with considerable cavities, 4 only had "disease arrested," 44 were "much improved," 39 were "improved," and 19 were "stationary or worse." Sir StClair Thomson examined 268 cases laryngoscopically, and in 32 of these local lesions were found; 25 were in the group of advanced disease. In regard to prognosis the statistics of ultimate results are rather striking. The table in which are grouped all cases discharged since 1906 in the sputum of which tubercle bacilli were demonstrated in the

sanatorium, shows that while after five years the number alive was only between one-third and one-half of the original number discharged, yet after ten years the number of deaths had been very little, if at all, increased.

GOATS AND GOATS MILK.

WHILE all the world comes to Britain to buy horses, bulls, sheep, and pigs, comparatively little interest has until recently been taken in goats. Their number in proportion to the population has been very small as compared with such countries as Switzerland, where goat-breeding has been studied for centuries. There has, however, long been a band of goat-keepers in this country, faithful though small, and information as to the choice of goats and the method of keeping them was available when, owing to the high price of milk and milk products during the war, public attention was turned to possible alternatives. Another circumstance which may lead to greater use of the goat in this country is the increase in the number of small holdings which is taking place in some parts of Great Britain, and especially, perhaps, in Wales. It has always been difficult for the small holder to get cow's milk; at the best he may have to send a long way for it, and at the worst none may be available, all being sent away to towns or converted into butter or cheese. For the small holder the goat is the ideal milk-yielding animal, and if skilfully managed is easy and economical to keep. It is true that to the unaccustomed palate the flavour of goat's milk is less agreeable than that of cow's milk, and, owing to its white colour, it has not the creamy rich appearance of cow's milk. Notwithstanding the colour, the percentage of fat in goat's milk is about the same as in cow's milk. We cannot agree with those enthusiasts who state that the goat is immune from tuberculosis, but it seems to be true that goats rarely suffer from that disease. It has also been stated that the milk of the goat is more nearly similar to mother's milk than the milk of the cow; but it differs so slightly from cow's milk that it has no advantage as a food for infants from that particular point of view. Yet the milk of the goat has valuable qualities, and goat-keeping and goat-breeding deserve every encouragement in this country. In this direction much useful spadework has been done for some years, and is being done to-day, by the British Goat Society, which has just published its first *Year Book*.¹ In this are included a large number of articles dealing with the goat, goat-breeding, and milk production. Prospective goat-keepers and goat-breeders will find the volume full of information, and it is well illustrated. The *Year Book* has been edited by the honorary secretary of the society, Mr. T. W. Palmer, and is published from the office at 5, Fenchurch Street, E.C.

BENVENUTO CELLINI'S MEDICAL EXPERIENCES.

CLOSELY allied to the psychological interest aroused by the history and trials of detected criminals is that derived from the candid confessions and diaries of J. J. Rousseau, Samuel Pepys, and Benvenuto Cellini. The last, though a thorough-paced rogue, has long had a fascination for the general reader and has been fortunate in his English biographers—John Addington Symonds and Augustin Birrell. Cellini (1500–1571) lived in eventful and lawless times, and as a highly artistic designer of jewellery and metal work played a prominent part in the Renaissance. During this period of the reformation and the revival of learning, medical practice was still hand-in-hand with quackery and superstition; the great epidemic of syphilis extended to Italy by 1494, and poisoning was a fine art in that country. It is therefore interesting to glance at Benvenuto Cellini's impressions and experiences of medicine as recently set forth by Dr. Jacob Rosen-

bloom,² of New York, and to compare and supplement them with Sir D'Arcy Power's³ paper on the same subject written in 1898. Cellini had plague at the age of 23, malaria more than once, and on one of these occasions drank freely of water against medical advice and promptly improved; he describes an illness lasting two months, and ascribed to the bad air of Pisa, which may have been enteric fever; he was the victim of gout in his later years, and had several surgical accidents, such as fracture of the leg and a splinter of steel in the eye. But perhaps the most interesting of his remarks are on the subject of his attack of syphilis—or as it was then called in Italy, the French disease—which remained dormant for four months and then suddenly broke out all over his body. After following for some time medical advice without any benefit, he took guaiac (introduced from America about the year 1508) against the orders of the first physicians in Rome, and after fifty days was "cured and as sound as a fish in water." But from exposure he fell into a slow (?syphilitic) fever, and in spite of the medical dictum that if he took guaiac with fever on him he would be dead in a week, he disobeyed and was well in four days' time. Later on he had a painful inflammation of the eyes, cured by a simple eyewash prescribed by the Pope; this is considered by Rosenbloom to have been a functional affection, whereas Sir D'Arcy Power thinks it was iritis. The practice of mercurial fumigation and inunction carried out by Giacomo da Carpi, who amassed a large fortune thereby, is mentioned by Cellini, with the sneer that the so-called French disease is very partial to priests and especially to the richest of them. He alleges that at least three attempts were made to poison him; in one pounded diamond was to be administered in his food, with the object of setting up acute enteritis in the way that pounded glass acts, but the man entrusted with the grinding substituted a soft stone—a greenish beryl—so enriching himself and incidentally, as Cellini believed, saving him from a painful death. When he was about 48, corrosive sublimate, or as Power suggests, arsenic, was put in his sauce and caused acute colitis, but, to quote his own words, "the poison worked so well that whereas, before I took it, I had but perhaps three or four years to live, I verily now believe that it has helped me more than twenty years by bettering my constitution." It would indeed be an irony of fate if an attempted criminal poisoning really benefited the intended victim by curing an existing disease, but Cellini's conclusions are often based on very insecure grounds. His comments on his numerous medical advisers are, as a rule, highly critical.

THE STATISTICS OF TYPHOID VACCINATION.

REFERENCE was incidentally made a short time ago to French statistics which it was thought showed the value of antityphoid vaccination from an unexpected angle. The evidence was presented by Professor Chauffard to the Académie de Médecine, and the argument was so ingenious that it is worth while to reproduce it. He ascertained the age and sex incidence of the disease at his clinic at the St. Antoine Hospital (Paris) before and after the war. During the years 1912–13 there were 11 men and 42 women, the mean age being 24 for the former and 27 for the latter. Under the age of 20 the percentage was 27.5 for men and 19 for women; after 20 years of age it was 72.5 for men and 81 for women. During the years 1918–19–20 there were 10 cases in men and 23 women. For the latter the mean age remained at 27, and the percentage under 20 years was 24.5, while after 20 it was 75.5. These proportions are virtually the same as in the pre-war statistics. But on the male side things have greatly changed, for while the mean age was 17.5 years, the percentage under 20 years of age was 90, and after 20 only 10. As a matter of fact all the male typhoid patients

¹ J. Rosenbloom, *Ann. Med. History*, New York, 1919, ii, 348–356. (Published 1920.)

² D'Arcy Power, *Quart. Med. Journ.*, Sheffield, 1898, vi, 199–218.

¹ *The British Goat Society's Year Book for 1921*. Price 1s. 3s. 5, Fenchurch Street, London, E.C.3.

in his clinic, with the exception of a man of 45 taken prisoner early in the war and unvaccinated, were between 16 and 18 years of age. The salient fact, then, is that there were no male typhoid patients except the very young who, not having been in the army, had not been vaccinated, while the female figures remained unchanged. This, Professor Chauffard contended, is an argument for applying this protective measure on a large scale among the civil population—a proposal which is receiving attention in France at the present time.

THE King has been pleased to approve that the honour of knighthood be conferred upon Dr. James Craig. Sir James Craig, who was elected President of the Royal College of Physicians of Ireland in October, 1919, is King's Professor of the Practice of Medicine in the School of Physic, Trinity College, Dublin, Physician to Sir Patrick Dun's Hospital, and Physician in Ordinary to the Lord Lieutenant. He was at one time President of the Leinster Branch of the British Medical Association, and is a member of the Irish Committee of the Association.

WE regret to announce the death, on April 23rd, of Mr. Henry Edward Juler, F.R.C.S., consulting ophthalmic surgeon to St. Mary's Hospital, London.

Medical Notes in Parliament.

[FROM OUR PARLIAMENTARY CORRESPONDENT.]

The Budget.

THE budget statement made by Mr. Chamberlain (for Sir Robert Horne, the new Chancellor of the Exchequer), on April 25th, had no surprise except the announcement of the National War Bonds conversion scheme whereby such loans maturing in the next five years may be funded on terms which appear to be advantageous to investors.

The balance sheet for 1920-21 showed an actual revenue of £1,425,985,000, against an estimate of £1,418,300,000, and an actual expenditure of £1,195,428,000, against an estimate of £1,184,182,000, thus affording a surplus of £230,557,900, which, with sums statutorily provided for debt reduction and Exchequer balances, gave a total sum of £259,500,000 for debt reduction within the year. The actual reduction was less by £3,000,000, owing to the influence of the exchanges in the redemption of foreign debt.

Under a change now made for the first time, the estimates for 1921-22 are divided into ordinary and extraordinary accounts. The ordinary revenue is forecasted to be £1,058,150,000, and the expenditure £974,023,000, leaving a surplus of £84,127,000, which, however, is subject to expenditure and losses due to the coal strike. The extraordinary receipts and expenditure accounts show an estimated revenue of £158,500,000 from the realization of war assets and a debt of £65,705,000 for liquidation of war commitments, giving a surplus of £92,795,000, subject to a liability on termination of railway agreements. The full surplus, subject to these two liabilities, is thus put at £176,922,000. Mr. Chamberlain reckons that there may be an ultimate surplus of £80,000,000 for the reduction of the National Debt; which, with sinking fund allowances, may afford a total cash provision of £103,500,000 for this purpose, which is very different from the sum of £259,500,000 in the year just ended.

These figures are based on the maintenance of the taxation of last year in all respects, save that the Excess Profits Duty is abolished, and that the higher charges on cigars and sparkling wines, having proved unproductive, are ended. The surtax on cigars is abandoned; and instead of 7s. per gallon tax and 33½ per cent. *ad valorem* duty on sparkling wines, the duty is made 15s. per gallon.

In connexion with the income tax, Mr. Chamberlain referred to the fact that a number of claims were being received under provisions which operated to relieve falling incomes during the war; it was clear that the intention of Parliament last year was to cancel those provisions for 1920-21 and future years, and his advisers were of opinion that that intention had been effected; but, to put the matter beyond doubt and to dispose of it quickly, it was proposed to insert declaratory provisions in this year's Finance Act to clear up the questions that were being raised.

It should be noted that the estimates for the current year (1921-22) include £120,000,000 to come from arrears of Excess Profits Duty. Mr. Chamberlain stated that the assessment standing amounts to £300,000,000, and a large addition has to be made; but, on the other side, there will have to be allowances for adjustments and relief, and that is why the estimate for the current year is comparatively small. A further sum will be available under this heading next year, but this will be very much less. Mr. Chamberlain added significantly he could not expect that the ordinary revenue for next year, 1922-23, would be more than £950,000,000; and the Chancellor of the Exchequer is taking steps for further retrenchment by Government departments next year.

In the course of the debate some doubt was expressed by several private members whether the estimate for revenue was not sanguine. It has to be remembered, however, as regards income-tax yield that the returns on business are taken on a three-years' average; and there the Chancellor of the Exchequer, whatever the depression in the past year, will be greatly helped by the figures of the two preceding years in assessing his demand. But that fact will not assist taxpayers in finding the requisite money, and the burden for them will be serious.

Tuberculosis Bill.

Measure through Grand Committee.

THE Public Health (Tuberculosis) Bill was taken in Grand Committee on April 22nd. Sir Watson Rutherford was in the chair, and about forty members were present. The first discussion took place on Clause 1, the text of which was as follows:

(1) Where the council of any county or county borough has, before the passing of this Act, made arrangements for the treatment of persons suffering from tuberculosis (including persons insured under the National Health Insurance Acts, 1911 to 1920) at or in dispensaries, sanatoria, and other institutions in accordance with a scheme or under an agreement approved by the Local Government Board, the Minister of Health, or the Welsh Insurance Commissioners, as the case may be, that council shall, for the purposes of this Act, be deemed to have made adequate arrangement for the treatment of tuberculosis so long as such scheme or agreement, with such modifications, if any, as the Minister may on the application of the council from time to time approve, continues in operation.

(2) Where the council of any county or county borough fails to make adequate arrangements for the treatment of tuberculosis at or in dispensaries, sanatoria, and other institutions approved by the Minister, the Minister may, after giving the council an opportunity of being heard, make such arrangements as he may think necessary for the purpose of such treatment.

Any expenses incurred by the Minister in arranging for such treatment may be paid in the first instance by the Minister out of moneys provided by Parliament, and the amount of any expenses certified by the Minister to have been so incurred shall be paid to the Minister on demand by the council and shall be recoverable as a debt due to the Crown.

Mr. Grundy proposed in Subsection (1) to leave out the word "where" and to insert "it shall be the duty of." As the clause stood it appeared to him that schemes already approved, whether adequate or inadequate, would be deemed quite sufficient, and he urged that there ought to be a review of all these schemes, and especially of those with respect to county boroughs. The amount of rate levied in the county boroughs varied from a farthing to fourpence in the £.

Sir Alfred Mond said it was impossible to accept the amendment, as it would change entirely the drafting arrangement of the bill without adding anything very material. The arrangements of the county and county borough councils were not continued under the clause. The schemes were considered adequate so long as they were satisfactory. Subsection (2) covered materially the point of the amendment. The bill was the result of very careful and lengthy negotiations with the councils and its passage into law at the earliest possible moment was of urgent importance. Sanatorium benefit expired at the end of a month. It was impossible to accept in Committee an amendment which changed entirely the character of an agreed bill and did not forward matters, but would really make obscure what was now clearer.

Mr. R. Richardson regretted that the Minister would not accept the amendment. It was known to many administering the measures with regard to tuberculosis that up to now the minimum has been aimed at. He believed that money spent by authorities to do the minimum, so that they might say they were doing something, was wasted money. Without such power of review it would be very hard for the Ministry of Health to ask councils whose measures had been approved to do more than they had already done. Yet the experience of those connected with National Insurance and friendly societies was that before anything could be done in 50 per cent. of the cases the disease had proved fatal.

Sir H. Nield, on behalf of the Middlesex County Council and the County Councils Association, supported the bill as it stood. This was not the time to suggest to local authorities that they must spend more and more rates.

Mr. Thomson challenged Sir A. Mond's assertion that the bill should be taken as agreed because the local authorities had generally accepted it through their associations. He submitted that Insurance Committees and their Sanatorium Committees

were much more concerned. The great bulk of expenditure on sanatorium treatment of insured persons was provided by the taxpayer and not by the ratepayer.

Dr. Farquharson put it to the committee that they should calm their enthusiasm for extensive and expensive schemes and treatment until the experimental stage of those treatment methods had been passed. Even the best scientific opinion was at the present time in great doubt as to the effect of sanatorium treatment in doing anything more than palliating for a short time the unfortunate position of the tuberculous person. He had read only the other day a magnificent book written by one of America's greatest physicians, who had made tuberculosis a special study. His conclusion was that a tubercle-free population would be absolutely unequipped for existence in this country. If a group of twenty or twenty-five children was reared until they were of adult age under conditions which precluded the possibility of tuberculous infection, and the time came when they would have to go into the world without this security, they would inevitably succumb. The infection would be so extreme that it would quickly sweep them away. Let it be recognized that what was being done was an experimental process which should not burden the taxpayers excessively. The more he read up-to-date science, and the older he became, the more he was thrown back on the wisdom of our grandfathers and grandmothers. They exposed their children to zymotic diseases because the occurrence gave them immunity. It was part of Nature's freely given immunity to the population of this country that the small doses of tuberculous infection that we get acted as a protection to us against a more severe attack.

Colonel P. Williams could not see the objection to the amendment, which aimed merely at speeding up the laggard councils. Mr. Charles Edwards supported the amendment, which he said was no reflection whatever on those councils who were doing their duty.

Sir Kingsley Wood asked the Committee to read the clause as a whole. All the agreements already made had been most carefully examined by the Minister of Health and his expert advisers. In every one of these cases the agreement had come up to the standard laid down by the Departmental Committee of 1912, which carefully inquired into the subject, and made recommendations as to what the proper standard should be. The second class of case—where a county authority had not made adequate arrangements—was equally provided for in the bill under Subsection (2). There was the further penalty upon backward councils that if they did not, after direction by the Minister, come up to the standard, they would be penalized throughout the course of whatever treatment they were directed to make. Unless a council was prepared to make arrangements with an insured person the Minister would not approve of an agreement. As regards expense, a million pounds was now being paid by the ratepayers and one million two hundred thousand pounds by the taxpayers.

Mr. W. Carter demurred altogether to the assertion by Sir Kingsley Wood that, in round figures, two million pounds represented a large sum for purpose. They had to reflect on the terrible loss of life from the disease. Mr. Tyson Wilson was afraid that the statistics with regard to the people who had been treated in sanatoriums during the last twenty years would show that a very large number had died of the disease within two years; therefore money ought not to be spared in trying to find a cure, but they ought, in the first instance, to invest money in research work. He supported the amendment. Mr. Charles White submitted there was too much legal phraseology and ambiguity in the drafting of the bill.

Dr. Elliot said he would vote for the bill as it stood because the essential thing was to get the co-operation of the local authorities. These bodies were more closely in touch with local conditions and local opinion than the House of Commons could possibly be. It would be the greatest injury to the public health if it came to be supposed that a policy was being dictatorially settled at Whitehall and forced upon a reluctant set of local authorities. He thought that in this case the local authorities would have to be left to work out their own salvation under the supervision, but not at the command, of the Ministry of Health.

The amendment was rejected by 23 votes to 10.

Sir R. Thomas moved to leave out the words:

"or under an agreement approved by the Local Government Board, the Minister of Health, or the Welsh Insurance Commissioners, as the case may be,"

and to insert instead the words:

"approved by the Local Government Board or the Minister of Health, or, in the case of Wales, under an agreement made with the King Edward the Seventh Welsh National Memorial Association and approved by the Welsh Insurance Commissioners or the Minister of Health."

His object was to get the Welsh National Association acknowledged by the bill. They had in Denbighshire one of the finest blocks of buildings in the country for the treatment of tuberculosis, and the work being done in the institution was wonderful.

The amendment was accepted.

Sir H. Nield moved to add at the end of Subsection (2) the words:

"This Subsection shall not apply in the case of any council which at the date of the passing of this Act is deemed to have made adequate arrangements as aforesaid, and which fails to continue to make such arrangements as reason only of the withdrawal of, or diminution in, the rate of contribution made from the Exchequer before the passing of the Act to the councils of county and county boroughs in aid of the treatment of tuberculosis."

The object was to protect local authorities against any possible withdrawal of the Exchequer grant. Sir A. Mond accepted the words as making an ultra precautionary provision.

Clause 2 as to approval of institutions was passed without discussion.

The next discussion was on Clause 3, the text of which stood as follows:

The powers of a county or county borough council in relation to the treatment of tuberculosis (other than the power of raising a rate or of borrowing money) may be exercised through a committee of the council or through a subcommittee of any committee, and the council and, subject to any directions of the council, the committee may appoint as members of the committee or subcommittee, as the case may be, persons (including members of insurance committees) who are not members of the council, being persons specially qualified by training or experience in matters relating to the treatment of tuberculosis, but not less than two-thirds of the members of such committee or subcommittee shall consist of members of the council.

Mr. Thomson moved to leave out the word "may" in order to insert "shall," and Lieut. Colonel Sir A. Warren strongly supported the amendment. Dr. Farquharson thought the local authorities should be trusted to use their own discretion, and Mr. T. Wilson, on behalf of the Labour Party, said they were prepared to leave the matter as it stood.

The amendment was negatived.

Clauses 4, 5, 6 and 7 were passed without discussion.

Mr. T. Wilson next moved the following new clause, which was accepted by the Government and by the Committee:

Without prejudice and in addition to any other power, whether under this or any other Act, every council of a county or county borough shall have power to make such arrangements as they may think desirable for the after-care of persons who have suffered from tuberculosis (including persons for the time being insured under the National Health Insurance Act, 1911, as amended or extended by any past or future enactment), and the foregoing provisions of this Act relating to committees and joint committees shall extend accordingly as though in those provisions the expression "treatment of tuberculosis" included such after-care.

Dr. Raw formally moved a new clause in order to point out that seamen arriving at any port in this country were no longer able to receive sanatorium benefit under the Insurance Act.

Sir Kingsley Wood gave an assurance of the sympathy of the Minister, and the clause was withdrawn as being out of order.

The bill was then passed to be reported to the House of Commons.

The report stage of the bill was taken in the House of Commons on April 25th. Major Henderson moved a new clause (similar to that submitted by Dr. Raw in Grand Committee) to bring the Seaman's National Insurance Society within the scope of the bill, explaining that the object was to obtain an assurance from the Minister of Health that the Government would take up this matter in the House of Lords. Sir A. Mond gave this undertaking and the motion was withdrawn. The bill was then read a third time and passed.

Tuberculosis Treatment Expenses.—In Committee of Supply, on April 14th, Lieutenant Commander Hilton Young (Financial Secretary to the Treasury) moved the resolution required to enable payment to be made by the Ministry of Health for the treatment of tuberculosis where it was not done by local authorities, the money in due course to be recovered from such authorities. The resolution was agreed to.

Ministry of Health Draft Orders.—Sir Alfred Mond moved, on April 14th, "That the Ministry of Health (Factories and Workshops, Transfer Powers) Draft Order, presented the 28th day of February, 1921, be approved." Dr. F. E. Fremantle recalled that the scheme under which the Ministry of Health was formed was threefold: First, it contained provisions for various services; secondly, certain powers were reserved that might be added afterwards; and, thirdly, there was a general power for taking over other health powers. Amongst the powers that were excluded were vital ones, at present administered by the Home Office. It was a very serious and sound criticism of the Ministry of Health in its original constitution that the whole question of health in the factories, as administered by the Home Office, should have been omitted. However, a very small contribution in the right direction was made by this Order. Incidentally, he said that it was extremely difficult to keep watch on what went on in the House. It was with the greatest difficulty that he obtained a copy of this order, which transferred the following powers and duties of certain sections of the Factories and Workshops Act, 1921: Section 61 (Prohibition of employment of women after childbirth), Sections 97 to 100 (Provisions relating to bakehouses), Section 109 (Making of wearing apparel where there is scarlet fever or small-pox), and Section 110 (Prohibition of homework where there is infectious disease). They were all pertinent to the Ministry of Health; but he felt sure that the House would agree with him that they were small details entirely out of relation to any comprehensive conception of the duties of the Ministry of Health as regards the health of the people in their working hours. He hoped, therefore, that this would be only a prelude to the natural transference by slow but steady steps to the Ministry of factory and workshop health matters. He hoped that when Sir A. Mond was familiar with the affairs of his office he would not think it adequate to rise in his place and bow his head, but would explain orders that he submitted to consideration. The question was then agreed to.

National Health Insurance: Medical Benefit.—In reply to Sir Croydon Marks, Sir A. Mond said that the number of persons in England and Wales entitled to medical benefit under National

Health Insurance was approximately 12,750,000. Figures were not available of the number of insured persons actually receiving (a) medical treatment, (b) cash benefits in particular weeks. The total number of insured persons in England and Wales who were receiving treatment for tuberculosis in sanatoriums or other institutions was 8,922 on March 1st, 1921, and 8,754 on March 1st, 1920. The number of non-insured persons receiving such treatment on those dates was not available, but the number of beds available for non-insured and insured persons in approved institutions for the treatment of tuberculosis was 17,894 on March 1st, 1921, and 16,432 on March 1st, 1920.

University Grants for Scotland and Wales.—Sir R. Thomas asked, on April 19th, whether the President of the Board of Education was aware that the total increase in the annual grants to the Scottish universities for the year 1920-21 amounted to £31,000, and in the case of the three constituent colleges of the University of Wales to £16,000, and that, taking population as the basis of comparison, the increase in the case of Scotland was about 96 per cent., and in the case of Wales only 44 per cent.; and that in the case of Scotland the increase was unconditional, but in the case of Wales was an advance by the Treasury equivalent to a penny rate to be raised by the Welsh county councils; whether the Minister was aware that the university building grant in the case of Scotland was £248,000, and in the case of Wales £50,000, and that on population basis Wales was entitled to £89,200. Sir H. Crank asked whether the Minister for Education knew that the grants for the Scottish universities were to a very large extent statutory grants made in return for revenues belonging to the university and commuted under the Act. Lieutenant Commander Young replied that the increased grants were as stated, but a further sum of about £24,500 was due to the University of Wales, under the pound for pound arrangement, and would be paid on certification of the levy of the penny rate. The percentage increase over the previous year would then be: Scotland 96 per cent. and Wales 111 per cent. He was not sure Sir R. Thomas calculated the university building grant in Scotland as £248,000. No building grants had been made since the present University Grants Committee was appointed in 1919, and returns relating to earlier dates suggested a figure very much lower. As regards the suggestion of injustice to Wales, Lieutenant Commander Young said the assistance given appeared to be, if anything, more favourable than that given to Scotland. On the basis of the number of full-time students in residence, the grant for students in Wales was more than twice the Scottish figure.

The Registration of Nurses.—Mr. Grundy asked the Minister of Health, on April 19th, whether the important work of the General Nursing Council for England and Wales was in charge of a junior official of the Ministry of Health who knew nothing of medicine or nursing, and who could not appreciate professional points which had to be adjusted between the three statutory authorities in the United Kingdom; and whether he would take whatever steps were necessary to avoid rules being forced on the English Council which might result in the boycott of the register when opened. Sir Alfred Mond replied that Mr. Grundy was misinformed. Questions relating to nurses' registration were dealt with in the ordinary course of departmental business by administrative and medical officers of appropriate standing, and subject to the Minister's instructions. The General Nursing Council had only been required to make such alterations in the rules as were necessary to bring them into conformity with the Act or to give effect to the intention of Parliament. Mr. P. Hall, on April 20th, asked whether the English Act for the registration of nurses, passed in December, 1918, had not been carried into effect, and that efforts were being made departmentally to coerce the General Nursing Council of England and Wales to agree to provisions incorporated in the rules framed under the Scottish Act of which the Council did not approve; and whether such provisions would have the effect of reducing its authority in certain important directions to that of a recording body under the Scottish Board of Health. Sir A. Mond said that Mr. Hall was under a misapprehension. The General Nursing Council submitted a rule purporting to give them a discretion to refuse to admit to their register nurses already on the Scottish and Irish Registers. He was advised on the highest authority that this was *ultra vires*, and he was bound to ask the Council to amend the rule; subject to the submission of an amended rule offering reciprocity provisions he would sanction at once the rules for the admission of existing nurses.

Medical Needs of the Auxiliary Division in Ireland.—The Irish Attorney-General stated, on April 14th, that the Auxiliary Division was not provided with its own special medical transport and that ambulance and other necessities of medical equipment were borrowed from the regular forces, and when required—an arrangement which the authorities deemed satisfactory. Lieut.-Colonel W. Guinness asked whether notice had been taken of the sufferings of many of the auxiliaries who had been wounded in the Longford Camp, and whether the Chief Secretary would consult the Director of Army Medical Services in Ireland as to what steps had been taken so that men suffering from grievous wounds should not be left lying in the open without proper attention, as had often happened. Mr. Dennis Henry promised to bring the matter before the authorities. Earl Winterton said that at Longford Camp men had been left lying about for twenty-four hours, because no proper provision was made for them, and because it was not the duty of the army authorities to convey them to the hospital. Mr. Henry repeated that the matter was receiving attention.

Pensions Appeal Tribunals.—Sir Gordon Hewart, in reply to Mr. T. Griffiths, said that the Act of 1919 provided that a Pensions Appeal Tribunal should consist of one legal representative, a disabled officer or a disabled man, and a duly qualified medical practitioner. He was informed that an ex-commissioned officer never sat as service member on a tribunal to hear appeals of ex-service men and non-commissioned officers. Representations as to the desirability of including industrial women in the membership had been received, but it was not considered desirable to increase the personnel as suggested.

Permanent Pensions for Disabled Men.—Mr. McLean asked, on April 14th, whether the Pensions Minister had received any representation from any Local Pensions Committee to the effect that when a man had been under treatment for two years he should be granted a permanent pension (or sooner) if the decision of the medical man was that the disability or disease was likely to be permanent. Mr. Macpherson said that under existing practice award of pension was made permanent when the medical advisers of the Department were able to certify that the disablement had reached the final and stationary condition. Of late he had received many representations in favour of the award of permanent pensions within specified periods, and he was now having the question thoroughly examined. The matter was one of great complexity, which required very careful consideration in the interests both of the State and of the disabled men.

Disability Pensions.—Sir T. Bramsdon asked, on April 22nd, whether the Pensions Minister was aware that, up to June, 1917, many disabilities were looked upon as not attributable to the service, but subsequently medical opinion modified, and these disabilities were now considered in some cases to be attributable to or aggravated by the service, and whether, as a matter of equitable treatment, all pensions could be reviewed according to the present policy of the Ministry. Mr. Macpherson said that pensions appeal tribunals had been established to deal with appeals against the decision that a man's disability was neither caused nor aggravated by his service. Any man invalided in the earlier years of the war with a disability held to be not attributable to service, and who had not yet appealed, might now put forward his claim through the Local Pensions Committee, and it would be reconsidered by the Ministry before submission to the tribunal.

Pensions Appeals Delay.—Sir Gordon Hewart, in answer to Mr. Davies, on April 21st, said that there were about 8,500 appeals waiting to be dealt with by the Pensions Appeal Tribunals established by the War Pensions Act of 1919. The twelve tribunals now sitting dealt with over six hundred appeals per week. Additional tribunals were being set up.

Light Metal Limbs.—Major Cohen, on April 21st, asked the Minister of Pensions the price of the Government's new light metal limb, both as supplied by Messrs. Vicars and also when completely fitted with buckets, etc. Mr. Macpherson said it would not be expedient at this stage to publish details of the contracts placed with the limb makers in connexion with the light metal limb. He could state, however, that for the first issue of five hundred the total cost per limb would not exceed £30; the limbs were provided free to the pensioners.

Pneumonia Attributable to Naval Service.—Sir T. Bramsdon asked, on April 20th, whether, in view of the stringent medical examination applied to new entries to the Navy in peace time, which should make attributability more pronounced in the case of death or invaliding, some form of independent appeal board would be substituted to deal with any post-war cases in dispute, inasmuch as pneumonia, for instance, might be clearly due to the naval service, but there was no machinery for recording the circumstances attending each case, nor for bringing them to the notice of the medical officers who had to decide this important matter. Mr. Amery replied that it was not considered that such a board was necessary. From the time that a man entered the Navy until he left it a careful record was kept of his medical history, and before he was invalided for injury or disease all the details were fully known to the Board of Survey, who definitely gave their opinion as to attributability. Such a disease as pneumonia might well, in exceptional circumstances, be definitely given as attributable to service.

Anatomical Studies.—Sir H. Brittain asked, on April 20th, whether the Minister was aware that there was the greatest difficulty with regard to the proper prosecution of anatomical study in this country, and that a large number of British medical students were forced to prosecute or complete their studies in foreign hospitals or universities; whether this difficulty was mainly due to the inadequate supply of dead bodies for anatomical studies; and whether he would appoint a Select Committee to inquire into the matter. Sir A. Mond replied that, although it was the case that students had occasionally gone abroad to seek facilities to study anatomy, the difficulty at home had been remedied now by action taken by his predecessor; there was still a shortage in the case of certain provincial schools, but this was being remedied.

A Caravan Settlement.—Mr. Stuart asked, on April 13th, as to the reply of the Minister of Health to the petition of the Moreton District Council upon the subject of the caravan settlement in that and adjoining parishes; whether an expert in the Ministry of Health has reported upon the settlement; whether it contains about 1,100 caravans, many of which had merely bogus wheels and pretended to be movable residences, whereas they were not so; whether many tents were added

during the summer months, increasing the population by many thousands; and whether the conditions (as alleged in detail by Mr. Stuart) were such as to create a great danger. Sir A. Mond said he had received the report from a medical officer of the Ministry of Health, which was substantially in accordance with the statements of fact in the question. He was advised that the local authority had already sufficient powers to deal with the serious factors in the situation, and he was in touch with them. Mr. Stuart inquired whether there was any way of limiting this evil in view of its alarming increase every year. The Minister repeated that the local authorities had full powers to deal with the matter. Mr. Stuart put it that an epidemic of typhoid fever was almost certain to arise, but Sir A. Mond said that it was the business of local authorities to see that these did not occur. Mr. Stuart said he was informed that the occupiers of caravans came to these places only in summer, and that the local authorities said they had no power to deal with them. Sir A. Mond rejoined that his advisers held to the contrary, but that if he found that the powers were inadequate he would go into the matter.

Harrow Medical Officer's Salary.—Mr. Mosley asked, on April 20th, whether the Minister of Health had requested the Harrow Urban District Council to raise the salary of their medical officer from the agreed sum of £180 per annum plus £20 allowances, to the sum of £230 per annum, plus £20 allowances. Sir A. Mond said that the approval of the Minister of Health had been asked for the appointment of a new medical officer of health at Harrow at the pre-war salary of £180 per annum plus allowances. The Urban District Council were informed that the salary was too low. The appointment and rate of salary were, however, sanctioned, as the council themselves contemplated an increase at the end of three months. On the application of the council an increase to £230, plus £20 allowances, was subsequently sanctioned.

THE BUDGET.

SELDOM during the past few years has a Budget been so effectively shorn of interest by anticipation or previous official announcement. Mr. Chamberlain publicly stated in Birmingham last February that the excess profits duty would be terminated and that no considerable change would be proposed in the income tax; and, as few would be sufficiently optimistic to expect any reduction in such duties as those on tea, tobacco, or spirits, in present circumstances, the main features of the new Budget have since then been regarded in the light of foregone conclusions.

The only surprise in his speech was that relating to the issue of a new loan to induce holders of bonds, the redemption of which is impending in the near future, to convert them into long-dated securities instead of claiming the redemption of their bonds, and thereby driving the Government to the money market for temporary loans, which would add to the already too heavy floating loans, aggravate the serious difficulty of the money market, and delay the hoped-for return to a lower bank rate and healthier conditions of industrial credit. The terms of the conversion loan seem to be sufficiently generous to ensure the attainment of its object.

Most of the fiscal controversies of the past few years have centred round the excess profits duty. The professional man, as such, is not directly concerned with that tax, but there is something to be said from his standpoint, for it is clearer than it ever was that a burden taken from the shoulder of one taxpayer implies either an additional burden on another taxpayer, or, as in the present instance, the retention of his burden without the relief that otherwise might have been afforded. A system of taxation should, if possible, comply with two main conditions: it should be fair as between one citizen and another, and it should inflict the minimum of harm on the citizens as a whole. The excess profits duty—or some modified form of it—is justifiable on grounds of equity in many cases, where an income greatly in excess of the pre-war income is still being enjoyed, but most if not all of the authorities seem to be agreed that its effect on the nation's industrial and commercial well-being is so harmful that it must go. Unfortunately, in this imperfect world, the two conditions are impossible of simultaneous fulfilment, and the man who is now enjoying an income which the war has helped him to double or more, is now freed from the special burden of the excess profits duty, not merely, or mainly, because that burden is unfair, but because the unfettered investment of his surplus income is desirable for the building up of industrial enterprises.

In this connexion the remarks of the Chancellor with regard to the operation of the three years' average are of interest. During the war provisions were very properly

inserted in the Acts to give relief to those taxpayers whose incomes had fallen owing to the war. That relief operated by suspending the three years' average, and it now appears that there is some doubt as to whether the law officers of the Crown are right in holding that that relief was abolished for 1920-21 and future years. The point is important, because if the relief does still operate the result would be that concerns which made large profits during the war would now escape their fair payment of income tax by substituting for the three years' average the profits of the comparatively unprofitable year 1920. For these reasons the course proposed—namely, to deal with the question by Act of Parliament instead of leaving it to the protracted and uncertain arbitration of the courts, appears right and proper.

The Budget has taken precedence of the second reading of the Revenue Bill, the intention of which is to effect certain changes in administration and in the average basis of assessment as for the financial year 1922-23 and future years. There has been considerable discussion in the daily press as to the wisdom or unwisdom of the administrative changes proposed. On the one hand the proposals are supported as merely giving legal sanction to the existing practice in accordance with which the greater part of the assessing work is performed in most places by the inspector of taxes, on the other hand the proposals are attacked as giving that official an authority and opportunity for harassing the taxpayer which he should not be allowed to obtain. A reference to the report of the Royal Commission on Income Tax shows that the Revenue Bill is in the main intended to embody the unanimous views of the members of that Commission, and it is perhaps wise to suspend judgement until the bill has been discussed in Parliament.

After all, the dominating factor in the situation is that the standard rate of income tax remains at 6s. in the £, and a close scrutiny of the Budget figures suggests little hope of its early reduction. At the moment the demand for economy is loud and insistent, and it is well that it should be so; but there is a constant parliamentary pressure for schemes of social betterment which goes far to nullify efforts to secure a smaller national expenditure. On the revenue side, Mr. Chamberlain deliberately omitted from his anticipations any receipts from the German Indemnity, which is earmarked against repayment of national debt; but taking into account, on the other hand, the fact that before long some arrangement must be arrived at with the United States as to the accrued but postponed interest on our debt to that Government, it requires more optimism than we can summon to our aid to anticipate much relief in taxation through Germany meeting her obligations to this country, and thereby reducing the interest payable on our own National Debt.

To the professional man the Budget appears to be without any very distinctive features, and leaves him very much as it found him, thankful that it is no worse, but with little hope for any early relief from a burden of taxation which can be borne only by great personal sacrifice.

THE Committee of Livingstone College recently accepted with much regret the resignation of Dr. Loitus E. Wigram of his post as principal of the college, and appointed as his successor Dr. Tom Jays, who has served since October, 1919, as vice-principal.

THE report of the Carnegie United Kingdom Trust for 1920 contains an account of the many-sided activities of this body, which range from the publishing of music to the provision of play centres for children. In connexion with the valuable work which is being continued in regard to the provision of public libraries, £500 was given to the College of Nursing for the formation of a nurses' library in their new headquarters in Cavendish Square. A grant of £40,000 is to cover the lease, equipment, and sinking fund charges of No. 117, Piccadilly, which is the house of the London Central Institute for Infant and Child Welfare and its constituent child welfare societies. Of the six model infant and child welfare centres for which grants had been promised, the Motherwell centre, the report states, was the only one actually in course of erection. Among the miscellaneous grants was one of £1,000 a year for five years to the National Institute of Industrial Psychology, which is complementary to the official body, the Industrial Fatigue Research Board, and is under the direction of Dr. C. S. Myers, F.R.S.

England and Wales.

DINNER TO MR. R. A. BICKERSTETH, LIVERPOOL.

A LARGE number of his professional colleagues and friends assembled on April 20th to do honour to Mr. Robert A. Bickersteth, M.A., M.B., F.R.C.S., on the occasion of his resignation from the position of senior surgeon to the Liverpool Royal Infirmary. The success of the dinner was due to the efforts of Mr. Frank Jeans. Mr. H. Wade Deacon, chairman of the committee of the Royal Infirmary, presided, and after the loyal toasts had been honoured, Dr. Richard Caton, senior consulting physician, proposed the health of the guest. Dr. Caton said that the name of Bickersteth was a household one in the annals of the Royal Infirmary, and he hoped that in the future the name would again appear among those of the surgeons of the infirmary. He trusted that their guest would enjoy many years of happiness in his retirement to the north of England. Mr. Frank T. Paul, consulting surgeon, mentioned especially Mr. Bickersteth's work in urinary surgery, and that, as a major during the great war, Mr. Bickersteth devoted his attention to the wounded at Fazakerley Hospital, relinquishing his private practice in order to do so. Mr. F. Jeans, assistant surgeon to the Royal Infirmary, who worked with Mr. Bickersteth, gave a delightful account of the harmonious relationship of his staff. Mr. Keith Monsarrat (Liverpool Northern Hospital), Mr. G. P. Newbolt and Mr. Douglas Crawford (Royal Southern Hospital) testified to the character and skill of their colleague, and congratulated him on his retirement at an age when he could look forward to many years of healthful activity. The chairman of the infirmary emphasized especially the great value of the tact and judgement that Mr. Bickersteth was able to render in the management of hospital affairs. Mr. Bickersteth, in reply, said that he was gratified beyond expression to know that in leaving Liverpool he had left behind him a secure place in the esteem of his professional brethren.

THE LATE DR. ARNOLD JOHNSTON OF LEICESTER.

Many professional and social friends of the late Dr. Thomas Arnold Johnston, assistant physician and pathologist to the Leicester Royal Infirmary, were present on April 21st at the unveiling of a memorial tablet commemorating his work at the infirmary. Mr. N. C. Ridley, M.B., F.R.C.S. (ophthalmic surgeon), senior member of the honorary medical and surgical staff of the institution, who performed the ceremony, said that the tablet commemorated the sacrifice of a life freely given in the sacred cause of humanity, offered at the call of duty, in fighting a subtle and insidious foe in the laboratory, so that knowledge might be gained to enable the human race more effectively to withstand the attacks of disease. "Arnold Johnston," Mr. Ridley continued, "was a quiet modest man, albeit of a cheery and lovable disposition, who never spared himself when there was work to be done. He knew quite well the risks he was running, but although on two previous occasions he had been laid up with the same infection, he returned to his work and unfortunately contracted the disease a third time; he eventually succumbed after two years of great suffering, mitigated indeed by the faithful care and attention of a devoted wife and loving mother. As the senior member of the staff and also because possibly I knew him best, I have been asked to unveil this tablet to his memory, to show to future generations that the Leicester Royal Infirmary appreciates her sons and laments a young and promising life cut untimely short. As Horace most aptly expresses it:—

Quis desiderio sit pudor aut modus
Tam cari capitis!"

The inscription on the tablet is as follows: "To the memory of Thomas Arnold Johnston, M.D., Honorary Assistant Physician and First Pathologist to this Infirmary. Obiit 4th February, 1918."

VITAL STATISTICS.

The Registrar-General announces that the provisional figures of births registered during the first quarter of 1921 show a decline of over 61,000 when compared with those of the corresponding period of 1920. Compared with the

first quarter of 1914, however, the drop in numbers is under 8,000. Excluding the war years the births are the fewest recorded in the first quarter of any year since 1872. The provisional rate per 1,000 living is, with the exception of the war years 1916-19, the lowest ever recorded for any first quarter. The deaths registered also show a decline in numbers from the very low record of 1920, and are the smallest in number registered in the first quarter of any year since 1868. The provisional rate is the lowest ever recorded for any first quarter. The natural increase by excess of births over deaths was over 80,000, as compared with 133,000 in the March quarter of 1920 and 73,000 in 1914. The infant mortality was 101 per 1,000 births.

Ireland.

THE NEW ULSTER PARLIAMENT.

Selection of Unionist Candidates for Queen's University of Belfast.

At a meeting of the Queen's University Unionist Voters' Association, held on April 20th, in the Minor Hall, Y.M.C.A., Belfast, the following four candidates were selected: John Campbell, M.A., M.D., F.R.C.S.Eng., LL.D. (Hon.); R. J. Johnstone, B.A., M.B., F.R.C.S.Eng., Professor of Gynaecology in the Queen's University; H. S. Morrison, M.D., L.R.C.S.I., H.M. Coroner Coleraine District; and John H. Robb, B.A., B.L., a member of the North-East Circuit, author of some legal works, and well known in the North of Ireland.

Mr. Campbell is senior surgeon to the Samaritan Hospital for Diseases of Women, Belfast, and is well known as a consulting and operating gynaecologist; he was chairman of the old Royal University Graduates' Association, and is Chairman of Convocation of the Queen's University; he served in France for a time as chief surgeon of No. 5 British Red Cross Hospital, and was adjutant and second in command of the Queen's University Veterans Volunteer Corps. Professor R. J. Johnstone is gynaecologist to the Royal Victoria Hospital, Belfast; he has been for twelve years a member of the Council of the British Medical Association, and was actively engaged in the negotiations between the Government and the profession in connexion with the Insurance Act; he has been chairman of the Irish Medical Committee for the past six years; he is a member of the Council of the British Hospitals Association and was chairman for two years of the Hospitals Committee of the British Medical Association, and is one of the three medical members of the Nursing Council for Ireland. He served during the war as one of the surgeons of the U.V.F. Hospital. Dr. H. S. Morrison was put forward by the Medical Association of the County of Londonderry, and his nomination was heartily approved of by the Queen's University Unionist Voters' Association. For thirty years he has been an active supporter of the Ulster Unionist policy, and he is chairman of the South Londonderry Unionist Association, and of the County Londonderry Branch of the Irish Union Alliance; he is secretary of the Irish Medical Association of County Derry and has held many posts of public utility; he has retired from medical practice but still holds the coroner'ship. Mr. Robb is a member of a medical family; his personal qualifications entitled him to the selection of the association; his claims were strengthened by his family record; his father (the Rev. J. Gardner Robb, D.D., LL.D.) was one of the early scholars of the old Queen's University, and his three brothers and himself have all passed through the portals of its successors: Dr. Gardner Robb, Medical Superintendent, Purdysburn Fever Hospital; Lieut.-Colonel J. J. Robb, I.M.S.; and Captain Campbell Robb, R.A.M.C., P.M.O., Egyptian State Railways. All were well-known athletes in their day.

POOR LAW MEDICAL OFFICERS AND LOCAL GOVERNMENT RETURNS.

The "department of local government, Dáil Eireann" over twelve months ago ordered Irish Poor Law medical officers to discontinue sending, amongst other returns, Form L to the Local Government Board (Ireland). Dr. L. Rowan, Kildare, one of the medical officers who has carried out the instructions of the Dáil Eireann local

government has written to the board of guardians, stating:

"I should be glad if you will communicate to the Board the fact that on the 10th inst. I received a communication from the Local Government Board (Ireland) in which they repeated the statement that the directions of your Board (re the September report) was illegal and invalid. They also express the opinion that resignation by me of my position as medical officer would have been in the circumstances 'the honourable way out.' They added that they had now decided to take a less drastic course than dismissal, and had directed their solicitor to apply in the High Court of Justice for a writ of mandamus to compel me to send in my report, all costs to be payable by me. I shall be glad to learn of and to follow any suggestion or procedure your Board may desire to adopt at this stage."

The board of guardians (Naas, co. Kildare) made an order that they would stand by Dr. Rowan and would indemnify him against any loss he may sustain arising out of any action taken by the "English" Local Government Board.

In connexion with this matter deputations from the Irish Medical Association and Irish Committee of the British Medical Association waited on the Vice-Chairman and Medical Commissioners of the Local Government Board to point out the difficulties in which medical officers in many unions were placed by receiving contradictory orders from the Local Government Board and their boards of guardians. In some instances they were placed in actual danger if they continued to obey the regulations of the Local Government Board. It appeared to the deputation that it was unreasonable to expect medical officers to jeopardize their salaries, or possibly their personal safety, by obeying the regulations of the Local Government Board in cases in which the Government no longer contributed to their salaries. The deputation failed to see why medical officers had been singled out of the whole class of officials with threats of dismissal for failure to obey the orders of the Board. The deputations also drew the attention of the Local Government Board to the fact that in several unions medical officers had received no salaries for over twelve months. Members of the deputation expressed the opinion that there was very little hope of such doctors being paid their salaries until legislation was introduced amending the Criminal Injuries (Ireland) Act, 1920, which provided for the attachment of Poor Law medical officers' salaries to meet the awards made for malicious injuries, including those committed by the Crown Forces. It was also pointed out that the Government had made no effort to provide medical treatment for the necessitous poor whose plight would be infinitely worse had not the Irish medical profession tried to place its services gratuitously at their disposal.

At a meeting of the County Limerick Medical Committee, held on April 16th, the following resolution was unanimously adopted:

That the order, regarding Form L, of our Board of Guardians be complied with, and that in future it be sent to them alone. That the Honorary Secretary is directed to send copies of this resolution to secretaries of County Borough and Local Medical Committees.

NATIONAL UNIVERSITY OF IRELAND.

At a special meeting of the Senate of the National University of Ireland, held on April 19th, with Dr. Denis J. Coffey, Pro-Vice-Chancellor, in the chair, Dr. Michael F. Cox proposed a motion recording the loss sustained by the university in the death of the Most Rev. William J. Walsh, D.D., Archbishop of Dublin, the first Chancellor of the University. The resolution, which was unanimously adopted, recorded that it was in the main to the efforts of Dr. Walsh that the university owed its foundation, and that its success in surmounting the difficulties of its early years was largely due to his wise guidance.

Scotland.

GLASGOW POST-GRADUATE MEDICAL ASSOCIATION.

A COMPREHENSIVE course of instruction for medical practitioners, extending from May to October, 1921, has been arranged under the auspices of this association. The hospitals taking part in the scheme include the Glasgow Royal Infirmary, the Western Infirmary, the Royal Hospital for Sick Children, the Royal Maternity Hospital and most of the other hospitals in Glasgow, the Glasgow Royal

Asylum, and the consumption sanatoriums for Scotland, Bridge of Weir. The classes have been arranged so that a practitioner may, if he so desires, occupy the greater part of each day in attending the classes and demonstrations of the course. In order to meet the needs of young graduates and others who may wish to obtain a closer acquaintance with hospital work in one or other of its branches, arrangements have been made by which a limited number may become attached to wards or out-patient departments as clinical assistants for definite periods, working under the direct supervision of the physician or surgeon in charge, and carrying out such detailed investigations as directed. A young graduate who wishes to obtain special knowledge of children's diseases, mental diseases, tuberculosis, venereal diseases, or other subjects, would find such training valuable. The post-graduate courses are conducted quite independently of the undergraduate courses, and a practitioner may enrol for one or other of several classes, and may attend for one or more months as he desires. Any further information may be obtained on application to Dr. A. M. Kennedy, secretary, Post-Graduate Medical Association, The University, Glasgow.

ADVISORY COMMITTEE ON THE WELFARE OF THE BLIND.

The Scottish Board of Health has appointed a committee to advise it on matters connected with the care and supervision of the blind, including any question which may be specially referred to the committee by the Board. There are fifteen members of this advisory committee, and it is rather surprising to find that only one of them is a medical man—Dr. George Mackay, P.R.C.S. Edin., than whom, of course, no better single selection could have been made. The secretary to the committee, to whom all communications should be forwarded, is Mr. W. R. H. Johnston, Scottish Board of Health, 125, George Street, Edinburgh.

Correspondence.

THE SITE OF OPERATION FOR EMPYEMA.

SIR,—May I venture to raise the question of the point of election in operation for empyema?

At a V.A.D. hospital during the war I was very much struck with the number of cases of lingering empyema. They were practically all alike in one respect, showing scars of successive operations of which the earliest was at the back.

Lately there has come under my care another case in which intermittent discharge is still taking place from the last operation wound. It is like all the others, presenting three scars, the first well to the back, the second about the mid-axillary line, and the last—where I think the first should have been—between the mid-axillary and nipple lines.

I am convinced that if the first operation had been performed at the last-named point this man would have been spared weeks of protracted suppuration together with two further operations.

In my student days in the eighties we were taught that the compressed lung lay at the back, and that in expanding after operation it gradually covered the inner surface of the ribs from behind forwards, the last portion to come in contact with the chest wall being towards the front. A posterior opening was therefore covered by the advancing lung while pus still remained in front, and drainage was thus interfered with; or if the opening were made too low the rising diaphragm might cover and obstruct it. Of course there are many cases in which the presence of adhesions may localize the collection of pus in any direction, but this was the teaching in respect of ordinary uncomplicated empyema, especially in children.

It is well summarized in Erichsen's *Surgery*, eighth edition, vol. ii, p. 701, where John Marshall is fully quoted in support of the anterior opening, the conclusion being:

"The space between the fifth and sixth ribs, an inch to an inch and a half in front of the mid-axillary line, will probably be the best in most cases."

I remember well the almost uniformly successful results of operation at this point both at St. Thomas's and at the Victoria Hospital for Children, Chelsea.

I was surprised to see these cases of posterior opening, until, in a modern *System of Surgery*—Burghard's, 1914—I found the posterior opening strongly supported (vol. iii, p. 711) by Sir Lickman Godlee, who says:

"I have no hesitation in recommending a posterior opening both on theoretical grounds and as a result of experience, the best place being, in my opinion, the region of the ninth or tenth rib, not far from the scapular line," and goes so far as to add: "I have often had to make a posterior incision when a lateral one has failed to effect a cure, but never to make a lateral one when a posterior one has proved inefficient." (The italics are mine.)

An old teacher of mine used to say that the opening of an empyema behind the mid-axillary line should be made a criminal offence.

Which of these teachings should we follow? It is a point which experience should have decided, and I shall be glad to learn what the decision is.—I am, etc.,

Bromsgrove, April 22nd.

H. CAMERON KIDD.

THE SCIENCE OF ETIOLOGY, OR THE NEW EPIDEMIOLOGY.

SIR,—It is very good-natured of your correspondent to remind me that the "problem of causation" is of interest to clinicians and bacteriologists; a little point like that might so easily be overlooked. One good turn deserves another, so I will "venture to remind" him that zeal on behalf of the problem of causation is an insufficient excuse for roundly asserting that epidemiologists, whether new or old, renounce the laborious accumulation of facts, and for hinting that some other persons have a monopoly of "persistent endeavour," of "well-controlled and repeated observation," in short, of all the qualities which go to make up genuine scientific work in any field.

In normal times these exaggerations are merely amusing; in times like ours, when all men seem to wish to believe that 2+2 is any number you like except 4, they are mischievous. To become a genuine bacteriologist is as hard as to acquire any other intellectual discipline; the mere patter of the subject is easily picked up. But the dullest man in the street perceives that to become familiar with the A B C of general epidemiology (quite apart from any special mathematical or statistical technique) is a laborious undertaking not to be completed in a few days. Nearly a hundred years ago Macaulay said that there were many persons "who, having read little, or nothing, are delighted to be rescued from the sense of their own inferiority by some teacher who assures them that the studies which they have neglected are of no value, puts five or six phrases into their mouths, lends them an old number of the *Westminster Review*, and in a month transforms them into philosophers."

Many of these people now seek to instruct the public in preventive medicine. What they want to be able to say is that the whole problem of disease as a mass phenomenon is reducible to the chasing of a "germ" and the discovery of a "vaccine," that the laborious accumulation—with apologies to your correspondent—of epidemiological facts and the statistical analysis of such facts are waste of energy. Of course these things will be said whatever we may do; nothing short of an earthquake will prevent the "medical correspondent" of at least one daily paper from announcing to the world that some old wife's tale or piece of laboratory tea-table gossip is the latest discovery of science. But for our own credit's sake we should give this "home chat" science no quarter in professional circles. It is simply not true that any particular school of medical investigators has a monopoly of wisdom or patent rights in the discovery of truth.

If bacteriologists have a fault—mind, I say *if*—it is that they have been a shade too complacent in accepting the homage of the man in the street or newspaper office on the look-out for a new Witch Doctor.—I am, etc.,

Loughton, April 23rd.

MAJOR GREENWOOD.

THE VALUE OF THE WASSERMANN REACTION.

SIR,—Three months ago a patient came under my care with a history of having contracted syphilis in March, 1920. He had no treatment until May, when he developed

a rash and a sore throat. The Wassermann reaction was then "strong positive." During the next eight months he was treated with seven injections of novarsenobenzol, combined with mercury in pill form.

In November last, he stated, the Wassermann reaction was still "strong positive." When I saw him there were no clinical signs of syphilis, but the blood serum when tested for the third time gave the same result.

Since January I have given him over four grams of novarsenobenzol with continuous mercurial treatment, and as I considered that this was a case in which the return of either a positive or a negative reaction was possible I decided to obtain the opinion of two pathologists independently. Even if they did not agree absolutely I hoped at least that they would not markedly differ. When, however, the first (1) report was "negative" and the second (2) was "doubtful strong positive," results not only dissimilar but even aggressively antagonistic, I sent further samples of the serum to three other pathologists. These reported (3) "negative," (4) "strong positive," and (5) "doubtful negative." Incidentally, I may state, I obtained a negative result by the new formalin reaction of Gaté and Papacostas. The five pathologists to whom I sent serum are all well-recognized and experienced authorities on the subject.

While one fully recognizes the value of the test, its advantages and its limitations, returns of the above kind with such divergent opinions are somewhat startling; and one wonders how often an unjust verdict is given upon an individual, and treatment or the lack of it advised, when his fate is settled solely by the report from the laboratory.

In view of these results it would be interesting to hear the views of other workers on this subject, whether clinicians or pathologists.—I am, etc.,

London, W.1., April 25th.

KENNETH DICKSON.

ETHANESAL ANAESTHESIA.

SIR,—I have used this new anaesthetic, "ethanesal," in several cases since attending the meeting of the Royal Society of Medicine at which its claims to recognition were publicly advanced, and I am bound to say that so far my limited experience in its use leads me to speak favourably of it. I have not, except in the case of children, used it by the "open method." I induce with ethyl chloride, or with nitrous oxide gas (the patient having received a preliminary injection of atropine sulphate gr.1/100), followed by ethanesal in a wide-bore Clover inhaler, and when induction is complete I pass on to ethanesal given by a "Shipway" outfit and warmed. I have found that by this method rather more anaesthetic is used than was formerly used of ether, but there are distinct advantages in respect of its after-effects to the patient.

I have on two occasions had to repeat the anaesthetization of patients who had been anaesthetized by me with similar methods by ether.

In one case the patient, a very obese lady, was anaesthetized by me for the removal of breast tumour. I used the same methods as stated above, except that ether was the anaesthetic used; she was very sick after the operation and also on the day following, and was nauseated by the taste of stale ether for several days. She was anaesthetized by me three weeks later for the complete removal of the breast, and this time ethanesal was used in place of ether. The second operation lasted more than twice as long as the first, but she was hardly sick at all afterwards; there was no prolonged nausea, and she was able to eat her breakfast next morning. When questioned as to the merits of the two anaesthetics, she was emphatic in her opinion as to the preferability of the new anaesthetic.

In the other case the patient was a boy, who was being operated upon for hypospadias. The boy was very sick after "open ether" administered by me with ordinary ether. On the second occasion I gave him ethanesal, also by the open method, and this time he was hardly sick at all, merely bringing up a little swallowed mucus.

I have given the new anaesthetic in two difficult abdominal cases, one a case of obstruction of the intestines by a band, the other a hysterectomy for fibroids complicated by multiple ovarian cysts in a patient of 62; in each case perfect relaxation was obtained, and in neither case was there any post-anaesthetic vomiting. I have administered the new mixture in two cases of piles, and in each the anaesthesia was satisfactory and resulted in good relaxation.

I think that ethanesal acts more thoroughly when administered warm, and for that reason, in the case of adults, and especially when the operation is likely to be prolonged, I use some form of "Shipway" apparatus. I have found that ethanesal is very apt to freeze on the gauze mask when administered by "open" or "perhalation" methods, and this probably accounts for Dr. Charnock Smith's inability to get good relaxation in the case he cites in your issue of April 23rd. My limited experience, in fine, does not bear out his contentions therein expressed, except in so far as the cost of the "ethanesal" is concerned, but this is of small moment where the after-comfort of the patient is concerned.—I am, etc.,

H. PINTO-LEITE,

Hon. Assistant Administrator of Anaesthetics,
the Westminster Hospital, etc.

London, W., April 23rd.

Sir,—Dr. Charnock Smith, in your issue of April 23rd, says that he has had difficulty with ethanesal as an anaesthetic, but as he only cites one case, and that one induced on a CE mixture, I venture to suggest that the conclusions he draws are not quite justified. This anaesthetic requires practice just as any other, and is quite different from ether in its effects. For instance, Dr. Smith mentions using 1 oz. in five minutes. I have never used anything approaching this quantity, and nearly always find that considerably less is required than with ether. This is because the liquid is more analgesic than ether, and patients can be kept lightly under. Dr. Smith also says that ethanesal anaesthesia is too light for abdominal or rectal work. It has been given in this hospital for practically every well-known abdominal and rectal operation, including hysterectomy, cholecystectomy, colectomy, gastro-enterostomy, gastrectomy, and ileo-sigmoidostomy, and no difficulty has been experienced in obtaining absolute relaxation. I personally have known of about 500 cases which have been anaesthetized with ethanesal by myself and other anaesthetists, and have not heard of one which could not be kept under with this anaesthetic only.—I am, etc.,

C. LANGTON HEWER, M.B., B.S.

St. Bartholomew's Hospital, London, E.C.,
April 22nd.

Sir,—After reading Dr. C. Charnock Smith's experience in the use of ethanesal in one case, I should like to give mine in twenty-one cases. The operations have been for tonsils and adenoids, mammary and other abscesses, varicose veins, multiple extractions of teeth, fistula in ano, etc.; in the last case a little chloroform, just before the operation started, was given with the ethanesal, 1 in 32.

In all the cases I have found ethanesal less irritating than ordinary ether; there was very little mucus and salivation, and the after-effects were practically *nil*—no headache, vomiting, nausea, smell or taste of the anaesthetic. Patients who have had both ether and ethanesal say they do not mind the latter, but they do not want ether any more.—I am, etc.,

ALBERT B. COCKER, M.R.C.S., L.R.C.P.

Palmer's Green, N.,
April 23rd.

Sir,—It is interesting, when so many investigators are engaged in working in the straight but very long road of science, that, as a report of the recent meeting of the Royal Society of Medicine shows, someone has had time and opportunity to go on a mission of discovery in the side lane of anaesthesia. The report suggests that this was not a blind alley, and that ethanesal has to a certain extent passed through the fire of use, and come out, if not pure gold, anyway a glowing piece of colour in the "anaesthetic rag-bag." As an uninterested anaesthetist, I wish to bear testimony to its value. Induction, which I obtained by the use of my percentage inhaler, was rapid when an extra strength was obtained by dropping the anaesthetic on gauze over the air pipe, and anaesthesia was easily maintained by bubbling oxygen at first through, but mostly over, jacketed ethanesal.—I am, etc.,

CHARLES T. W. HIRSCH,
Anaesthetist, Samaritan, London
Temperance Hospitals.

London, S.W., April 21st.

PRURITUS ANI.

Sir,—I am in agreement with much that was said at the discussion on April 13th on pruritus ani by the Subsection of Proctology of the Royal Society of Medicine (reported in the JOURNAL of April 23rd), more especially with the statement that in the local treatment attention to cleanliness and dryness and avoiding the use of ointments and greasy preparations is of the first importance.

A point, however, which seems to have been overlooked by all who spoke on treatment is the important one of shaving away all hairs found growing around the anus and between the opposing surfaces of the hips. In some cases no hairs are found in that region, but in many where the disease exists I have found that the hairs, by occasioning irritation of the skin, were the prime cause of the itching. I instruct the patient to wash the parts with warm water and soap after defaecation; then to use a safety razor in removing all hairs, finally to douche the parts with either boracic lotion or plain water or both, hot or cold, and dry carefully with a soft towel. This washing is to be carried out after every movement of the bowel, and again before retiring to rest. The shaving will require to be repeated about every ten days, and does not occasion any inconvenience. By attention to these details cures may be quickly effected in cases that have given trouble for years and after the failure of varied treatment.—I am, etc.,

Londonderry, April 25th.

D. A. McCURDY, F.R.C.S.I.

IRRITABLE BLADDER.

Sir,—There is little doubt that in certain cases the chemical and physical properties of the urine play an important part in the causation of increased frequency of micturition. One of your recent correspondents refers to alkalinity of the urine, and I would point out that unless the indicator used be stated, or some other means of denoting ionic concentration be employed, the terms acid and alkaline are very vague. During the past two years I have titrated a considerable number of specimens of urine from various sources, and using phenolphthalein as an indicator have only on one occasion found an alkaline reaction, even after the patients had been treated with bicarbonates and citrates of sodium, although such treatment may rapidly reduce the acidity as shown by titration.

It is probable that the osmotic pressure of the urine is at least as important a factor in causation of frequency of micturition as the reaction to indicators, since the ingestion of large amounts of sodium chloride may produce irritability of the bladder. A method of treatment worthy of consideration is to impress upon patients the necessity of drinking larger amounts of water than they have previously been taking; this will frequently produce satisfactory results.

In certain cases the administration of methylene blue capsules in addition has a beneficial effect, not only on account of the medicinal properties of this drug, but also by reason of the psychological influence of the coloured urine, which makes patients realize that something is being done for them.—I am, etc.,

Bristol, April 19th.

OLIVER C. M. DAVIS.

Universities and Colleges.

UNIVERSITY OF MANCHESTER.

The following appointments have been made: Reader in Electro-chemistry, Mr. A. G. Lobley. Lecturer in Practical Surgery, Mr. E. D. Telford. Clinical Lecturer in Mental Diseases, Dr. John Sutcliffe. Lecturer in Mental Diseases, Dr. David Orr.

A large number of French books presented by the French Government have been placed in the University library.

UNIVERSITY OF DUBLIN.

TRINITY COLLEGE.

At the first summer commencement in Trinity Term, held on April 19th, the following degrees in medicine, surgery, and midwifery were conferred:

M.B., B.Ch., B.A.O.—I. A. Acheson, D. J. Browne, T. F. J. Cary, R. S. Chapman, R. H. J. M. Corbet, P. J. Healy, L. Horzenberg, Mary Moran, D. V. Latham, J. D. Leahy, P. I. Levitt, R. W. Power, E. C. Smith (B.Ch. stip. cond.), J. A. Smith, Elinor D. Stopford. *In absentia*: D. de Bruyn, P. Y. Pratt, R. H. Saichwell, J. B. Taylor (antea lic), M.D.—H. Muller.

ROYAL COLLEGE OF SURGEONS IN IRELAND.

Honour for American Surgeons.

At a meeting of the President, Vice-President and Council, it was unanimously resolved to confer the Honorary Fellowship of the College upon the following distinguished American surgeons: W. J. Mayo, Mayo Clinic, Rochester, U.S.A.; C. H. Mayo, Mayo Clinic, Rochester, U.S.A.; Geo. E. Brewer, New York; Geo. W. Crile, Cleveland, Ohio; Richard H. Harte, Philadelphia; W. W. Keen, Philadelphia; John M. T. Finney, Baltimore; A. J. Ochsner, Chicago. It is hoped that the ceremony will take place in the early autumn.

Obituary.

ARTHUR F. DOBBS, M.B., T.C.D.,
Athlone.

DR. ARTHUR FRANCIS DOBBS died unexpectedly on April 20th. As usual with him, he was early at work in the Military Barracks, where he complained of not feeling well and was brought home. Late in the day he became unconscious, and before the evening sun had set he had gone to his reward.

He entered Trinity College, Dublin, in the early seventies, and had had a brilliant career in the arts school before entering the medical, from which he graduated M.B., Ch.B. in 1877. After practising for some years in the Federated Malay States he started in private practice in Athlone, where in a short time he acquired a large and widely spread practice, becoming successively civil surgeon to the military, medical attendant on the police, the post office, the Great Southern and Western Railway and to the Incorporated Society's schools. His opinion was much sought after by his colleagues, who warmly appreciated the unerring rectitude of his ethical sense, his wide knowledge of professional matters and accuracy of diagnosis, coupled with an intimate knowledge of the newer developments.

Those who knew Arthur Dobbs and who were his friends will miss much more than a genial colleague. He was descended from a race which has helped to mould the history of the country in the Irish Parliament, and which had an hereditary appanage in the borough of Carrickfergus, of whom perhaps the most distinguished member was that Francis Dobbs who occupied no small place in the ranks of the county members during Grattan's Parliament, and who is frequently spoken of in the records of the period as "Millennium" Dobbs, from a pamphlet he wrote proving the immediate imminence of the millennium, which was one of the reasons he adduced against the Union in the closing stages of Grattan's Parliament. Lecky records of him that "He was a man of respectable family and private means, of an eminently pure, gentle, honourable, and benevolent character." The words apply with equal force to his descendant, except as to the private means. Arthur Dobbs was hospitable, kindly, courteous, and benevolent, placed his best services at the disposal of the poor and needy as readily as at those of his richest clients. J. M.

Sir ARTHUR BALL, F.R.C.S.I., writes: The death of Dr. Arthur Dobbs, of Athlone, will be felt as a personal sorrow by many medical men in Ireland, and all classes, particularly the poor over a wide area in the Midlands, will truly mourn his loss. Dr. Dobbs was of the type of practitioner that is unfortunately dying out in this country—a man able to get on well with those of all classes, creeds and politics. Although working away from modern hospital facilities, he kept himself up to date by post-graduate classes and books in a wonderful manner. He was a man of considerable resources in emergencies—he had operated on a strangulated hernia successfully in a dirty cottage, with no assistance and by the light of a candle. Another instance: Called to see a poor woman far out in the country, he found her enormously distended, apparently dying from intestinal obstruction; it was impossible to get her moved to a hospital and no surgical aid was available. Instead of leaving her to die, Dobbs followed what I believe is a method sometimes carried out in cattle, and punctured the obstructed bowel through the abdominal wall in several places with a hypodermic needle and allowed the flatus to escape, with the result that the patient improved and he was able to get her moved to Dublin the following day, where the obstruction was successfully dealt with by operation. A life saved by taking a risk which most of us would have hesitated to

take. Military duties during the war and the tragic state of the country since prevented him taking any rest from his work. He had on several occasions during the past year intended taking a few days' rest, but something always turned up to prevent him. Want of rest, the strain of the present troubled times caused the end, but he died, as I am sure he would have wished, at the post of duty.

DR. DAVID VALENTINE REES died at his residence at Brecon, on April 13th, aged 67. He was educated at Llandovery College and the London Hospital, and took the diplomas of M.R.C.S. in 1875 and that of L.R.C.P. Lond. in 1876. After serving as house-surgeon and house-physician at the London Hospital and junior house-surgeon to the Poplar Hospital, he commenced practice forty years ago in Brecon, where he built up a wide and influential connexion. At the time of his death he was senior surgeon to the Brecknock Infirmary, M.O.H. to the Urban District Council, and a member of the War Pensions Medical Board. During the war he served at the Penoyre (Brecon) and Builth Wells Red Cross Hospitals and did a great deal of work at the Brecon barracks in addition to serving on the local medical board. He was awarded the O.R.E. in 1919. For twenty-six years he held a combatant officer's commission in the local volunteers and their successors, the Territorials, and had attained the rank of major. He was a J.P. for the county and a member of the North Glamorgan and Brecknock Division of the British Medical Association. He is survived by his widow and one son.

DR. FREDERICK J. BURMAN of Wath-on-Dearne, whose death from injuries caused by a motor-car occurred on April 15th, was educated at Leeds. He took the diploma of M.R.C.S. in 1883, and L.R.C.P. Edin. and L.M. in 1886. He had resided in Wath-on-Dearne, and ultimately succeeded to the practice established by his grandfather and afterwards carried on by his father. He was medical officer of the Wath, Rotherham, etc., Joint Hospital, M.O.H. and medical officer and public vaccinator for Wath-on-Dearne, certifying factory surgeon, and a member of the Barnsley Division of the British Medical Association. He was also an examiner for the St. John Ambulance Association and a vice-president of the Yorkshire Branch of the Society of Medical Officers of Health. For the last two years Dr. Burman had held the position of vicar's warden at the Wath parish church. He leaves a widow and one daughter.

DR. SAMUEL WALKER, one of the oldest medical practitioners in Middlesbrough, died on April 17th, aged 77. He received his medical education at Guy's Hospital, and took the diplomas of M.R.C.S. Eng. and L.S.A. in 1870. After serving as house-surgeon at the West London Hospital and the Northampton Infirmary he commenced practice in Middlesbrough. He was a J.P. for Middlesbrough, and an ex-President of the North of England Branch of the British Medical Association. He had been a Freemason for forty years, and was the oldest past-master of the Ferrum Lodge, and in addition held high degrees in another lodge. His wife died about two years ago, but he leaves three daughters and two sons.

THE death is reported of Dr. ALFRED ERNEST W. RAMSBOTTOM, of Heilbron, Orange Free State, aged 60. He was born at Grahamstown, the son of Mr. William Ramsbottom. He received his medical education in Dublin, and took the diplomas of L.R.C.S.I. in 1882, L.R.C.P.I. and L.M. in 1883, and F.R.C.S.I. in 1896, and graduated M.D. Durh. in 1902. He practised at Fauresmith and Bloemfontein, and acted as chief medical officer of the Orange Free State forces during the Boer war. On the conclusion of peace he resumed his practice at Bloemfontein, but in recent years carried on his medical work at Heilbron. He was a member of the Orange Free State and Basutoland Branch of the British Medical Association, and held the portfolio of treasurer of the Orange River Colony from 1907 to 1910, when he was appointed the first administrator of the Orange Free State on the formation of the Union of South Africa. It was while on a visit to London with reference to post-graduate study that he was seized with illness which proved fatal.

Medical News.

THE course of lectures on pathological research in its relation to medicine commenced at the Institute of Pathology and Research, St. Mary's Hospital, Paddington, on April 28th, when Sir Almroth Wright dealt with acidosis and acidemia, with special reference to gas gangrene, shock and scurvy. Professor Leonard Hill will lecture on May 5th, at 4.30 p.m., on capillary blood pressure and oedema. The lecture on May 12th will be given by Sir James Mackenzie, who will urge that the opportunities of the general practitioner are essential for the investigation of disease and for the progress of medicine.

THE next course of lectures by the Gresham Professor of Physic will be delivered by Sir Robert Armstrong-Jones, M.D., on May 2nd, May 3rd, May 4th, May 6th, at 6 o'clock, at Gresham College, Basinghall Street, E.C. The subject will be "Our Drinks: water, milk, wines, ales, and spirits." The lectures are free to the public.

THE number published on April 15th of the *Periodical*, a circular issued by the Oxford Press, announces that "the *Lancet* has come under the control of Henry Frowde and Hodder and Stoughton (Oxford Medical Publications), but there will be no change in the editor or the policy of the paper."

AT the meeting of the Röntgen Society in Manchester next Friday (May 6th), the afternoon session will begin in the Physics department of the University at 4.30, when a series of demonstrations will be given. There will be a dinner in the Refectory at 6.30, and the evening session, when the application of radiology to the examination of metals will be explained by Professor W. L. Bragg and the Director of Radiological Research, Royal Arsenal, Woolwich, will begin at 7.30. Saturday will be spent in visiting the x-ray and electrical departments of the Royal Infirmary and Radium Institute, and various works will be open to inspection. The meeting is open to non-members, who can obtain further particulars from the honorary secretary, Dr. R. W. A. Salmund, 51, Welbeck Street, London, W.1.

THE annual dinner of the Indian Medical Service will be held at the Trocadero on Wednesday, June 15th, Major-General Sir R. Havelock Charles, G.C.V.O., in the chair. Tickets and all particulars may be obtained from the joint honorary secretary, Colonel J. J. Pratt, I.M.S.(ret.), 63, Addison Road, Kensington, W.14.

DR. WILLIAM HUNTER will give a course of three Chadwick public lectures on the prevention and control of fevers in England, with special reference to the effect of the Public Health Acts (1848-1918). This review of a century's progress will be illustrated by maps and epidiascope pictures and diagrams. The lectures will be given at the house of the Medical Society of London (11, Chandos Street, W.1) on Thursdays, May 5th, 12th, and 19th, at 5.15 p.m.

THE Executive Council of the National Association of Insurance Committees, at a meeting held on April 15th, adopted a resolution placing on record its appreciation of the great service rendered by the Right Hon. Christopher Addison, M.D., M.P., in the cause of public health, and its grateful recognition of the prominent part he took in the establishment of National Health Insurance and his work as first Minister of Health. They expressed the hope that the policy initiated by him at the Ministry of Health will be vigorously pursued.

AN agreement has been made between Sweden, Norway, and Denmark to draw up a common pharmacopoeia.

THE celebrated anatomist and anthropologist Professor Heinrich Wilhelm von Waldeyer has recently died in Berlin in his 85th year.

THE first number of the *American Journal of Tropical Medicine*, bearing date January, 1921, has now reached this country. It is described as the official organ of the American Society of Tropical Medicine, and this first number contains the address of the president, and a report of the secretary for 1919-20, together with a list of members. The first paper consists of medical notes on the Dominican Republic and Haiti, and another deals with the carriers of *Entamoeba dysenteriae* among soldiers returned from overseas. Among the conclusions of this paper are that the number of carriers in the United States has been greatly increased by infections in soldiers returning from overseas, and that a larger number of carriers than has hitherto been suspected exists in the normal population. The annual subscription to British subscribers is 23s., and the publishers are Williams and Wilkins Company, Baltimore, U.S.A.

AT a meeting of the Naval, Military and Air Force Hygiene Group of the Society of Medical Officers of Health, to be held, with the kind permission of the Commandant of the College, at the Royal Army Medical College, Grosvenor Road, S.W.1, on Friday, May 6th, at 4 p.m., Lieut.-Colonel P. S. Lelean, C.B., Professor of Hygiene, will give a demonstration of "Sanitary appliances of interest to all health officers." The demonstration is open to all members of the society.

WE are asked to state that there is no foundation for the rumour that the baths at Harrogate are closing down owing to the coal strike.

THE Scottish Board of Health has issued regulations extending the period in which chicken-pox is compulsorily notifiable until October 1st, 1921.

SIR ARTHUR NEWSHOLME, K.C.B., arrived at Liverpool on April 25th, after completion of his engagement at Johns Hopkins University.

THE second annual dinner and reunion of officers of No. 20 General Hospital, B.E.F., will be held at the Florence Restaurant, Rupert Street, W.1, on Saturday, May 14th, at 7 for 7.30. Those who wish to be present are asked to apply on or before May 2nd to the Honorary Secretary, Mr. Harold Drinkwater, 7, Cavendish Place, W.1.

MAJOR J. H. DOUGLASS, O.B.E., M.D., R.A.M.C., of Lincoln's Inn, and Dr. T. M. Davie, M.C., of the Inner Temple, have been called to the Bar.

A COURSE of ten lectures on elementary psychotherapy will be given by Dr. H. Crichton Miller at the Kingsway Hall, Kingsway, W.C., on Fridays, beginning May 6th, at 5.15 p.m. The fee for the course is £2 2s. for medical practitioners and £1 1s. for medical students. Tickets can be obtained from the honorary lecture secretary, 51, Tavistock Square, W.C.1.

REUTER'S agent, telegraphing from Alexandria on April 21st, stated that plague had broken out in Egypt, a daily average of 35 cases being reported. Vessels are detained in quarantine at Alexandria. Three hundred and forty-two cases of plague occurred in Java during January, and 333 in February, all of which were fatal.

THE New York Institute of Radium has recently acquired 500 mg. of radium.

ABOUT a year ago we published a short note by Dr. D. W. Sanways of Mentone about Brides-les-Bains, sometimes called the French Carlsbad, because the water very closely resembles the Sprudel source at Carlsbad, the total mineralization being about the same, the constituents very similar, and the quantity of free carbonic acid gas identical. Dr. Jean Leray, who practises at Brides, informs us that the establishment and baths have been greatly improved, as has also the hotel accommodation. The place is reached through Aix-les-Bains, the nearest station being Moutiers.

ON June 18th next will be celebrated the octocentenary of the founding of Reading Abbey by King Henry Beaulere. In honour of the occasion Mr. Elliot Stock will publish an illustrated memorial volume by Dr. J. B. Hurry.

A SPECIAL meeting of the Fellows of the Royal Society of Medicine was held on April 25th to consider the recommendation of the Council that the subscription of all the Fellows in the London postal area should be raised to five guineas, and that of Fellows residing elsewhere in the United Kingdom to four guineas; to this recommendation an amendment was moved by Dr. H. H. Dale and seconded by Dr. W. Bulloch, to the effect that while the subscription for Fellows with an address within a mile of the Society's house should remain at five guineas as at present, and the subscription for Fellows residing elsewhere should be raised to four guineas, one guinea should be remitted from the subscription of any Fellow who did not desire to receive the *Proceedings*. In the discussion which ensued it became evident that the majority of those present were in favour of drastic reduction in the size and circulation of the *Proceedings*. It was pointed out that the proposal might have a serious effect on the original agreement for the amalgamation of the societies whereby the Royal Society of Medicine was formed. The amendment, however, was pressed on two grounds. First, that the vote would afford evidence of the general feeling regarding the *Proceedings*, and secondly, that it would avoid resignations, especially from the "laboratory" sections. When put to the meeting, 84 voted for the amendment and 53 against. As a two-thirds majority was requisite, the amendment is not operative as it stands, but the suggestion it contains will be considered by the Council of the Society, and the matter brought before a future meeting of Fellows.

Letters, Notes, and Answers.

As, owing to printing difficulties, the JOURNAL must be sent to press earlier than hitherto, it is essential that communications intended for the current issue should be received by the first post on Tuesday, and lengthy documents on Monday.

ORIGINAL ARTICLES and LETTERS forwarded for publication are understood to be offered to the BRITISH MEDICAL JOURNAL alone unless the contrary be stated.

CORRESPONDENTS who wish notice to be taken of their communications should authenticate them with their names—of course not necessarily for publication.

AUTHORS desiring reprints of their articles published in the BRITISH MEDICAL JOURNAL are requested to communicate with the Office, 429, Strand, W.C.2, on receipt of proof.

In order to avoid delay, it is particularly requested that ALL letters on the editorial business of the JOURNAL be addressed to the Editor at the Office of the JOURNAL.

THE postal address of the BRITISH MEDICAL ASSOCIATION and BRITISH MEDICAL JOURNAL is 429, Strand, London, W.C.2. The telegraphic addresses are:

1. EDITOR of the BRITISH MEDICAL JOURNAL, *Aitiology*, Westrand, London; telephone, 2630, Gerard.

2. FINANCIAL, SECRETARY AND BUSINESS MANAGER (Advertisements, etc.), *Articulate*, Westrand, London; telephone, 2630, Gerard.

3. MEDICAL SECRETARY, *Medisecra*, Westrand, London; telephone, 2630, Gerard. The address of the Irish Office of the British Medical Association is 16, South Frederick Street, Dublin (telegrams: *Bacillus, Dublin*; telephone, 4737, Dublin), and of the Scottish Office, 6, Rutland Square, Edinburgh (telegrams: *Associate, Edinburgh*; telephone, 4361, Central).

QUERIES AND ANSWERS.

"HEALTH OFFICER ABROAD" inquires for any official pamphlet on lethargic encephalitis.

. The Ministry of Health, as recorded in our issue of March 5th, p. 357, has issued a pamphlet (I.L.M. Stationery Office, through any bookseller, ld.) on the symptomatology, diagnosis, and treatment of lethargic encephalitis.

"PUZZLED" writes: Can anyone suggest a treatment for the most intolerable itching following supraorbital herpes. There is no pain, but the itching is so severe that the patient literally tears holes in her forehead and scalp. I have divided the supraorbital nerves, but with no benefit. The victim is a lady of 45, and the attack of herpes occurred in September, 1920.

X-RAY DERMATITIS.

"J. A. P." asks for advice in the treatment of a case of x-ray dermatitis on the back of the head and the front of the thighs. Only starch poultices give relief, but the trouble is slowly spreading; the patient is also suffering from nephritis.

INCOME TAX.

"A. G." inquires as to the allowance of expenses incurred in connexion with purchase and sale of cars. The transactions were as follows:

1913. 11.5 h.p. car (A) bought for £235.
1916. This having broken down and its immediate repair being impracticable another make (B) was bought for £135, and that amount was allowed by the tax inspector.
1920. The first car (A) was sold for £90, and a third car—11.9 h.p. (C)—bought for £545.

The inspector considers that for income tax purposes (C) is replacement of (B).

. It seems to us that the net cost of using the (B) car was a special expense arising out of the break down of the (A) and was not a replacement. In that case "A. G." would be entitled to a further allowance as follows:

Gross cost in 1920 of a 11.9 h.p. (A) or equivalent—say	£500
Deduct	
(1) Amount obtained for (A)	£90
(2) Amount obtained for (B)	85
	175
Net amount to be allowed	£325

If (B) is to be regarded as a replacement of (A) and (C) as a replacement of (B) "A. G." is still entitled to a further allowance equivalent to the difference between the cost price of a 11.5 (C) in 1920 and £90 plus £135 (the original cost of (B)). The amount to be deducted from the expenses in respect of the private use of the car depends so much on the circumstances that no general rule, 10 per cent. or otherwise, seems applicable.

"X" gave up his practice and has since done work as a locum tenent. How does this affect his liability?

. In our opinion the earnings as a general practitioner, assessable under Case I, Schedule D, cannot properly be averaged with prior or subsequent earnings as a locum tenent, such earnings being the result of "employment" and consequent assessable under Case II, Schedule D. This

contention is supported by the fact that the practitioner earnings fall into the average of the purchaser of the practice. We suggest that "X" should claim, as he has a legal right to do, to have his case set down for hearing by the Income Tax Commissioners and that he write to the inspector of taxes accordingly.

"IGNOTUS" asks: Can a salaried assessor of the Ministry of Pensions who, by the terms of his contract, is not allowed to practise, claim a deduction for expenditure on medical books and subscriptions to medical societies, both being necessary for keeping up his medical knowledge?

. Yes, provided that the expenditure is exclusively incurred for that purpose; no doubt other purposes are also served to some extent, but it would seem to be splitting hairs to urge that the claim should be refused on that ground.

"E. M. D." inquires whether a grant from the Medical Research Council is liable to tax.

. We understand that a substantial portion of the grant has been necessarily expended in carrying out the research for which the grant was paid. We are of opinion that for tax purposes the surplus over and above such expenditure must be regarded as a fee paid for work done, and as such is assessable. Particulars of the deductions claimed for expenses should be given on the space provided on the Schedule E form of declaration.

LETTERS, NOTES, ETC.

MESSRS. PARKE, DAVIS AND Co. have issued a descriptive catalogue of the products of their laboratories, which also contains in an "index of therapeutics" many suggestions for treatment. From the same firm comes the tenth edition of the little book entitled *Vaccine Therapy*, which contains instructions for using the vaccines prepared in the laboratory of St. Mary's Hospital. Considerable alterations have been made in this edition, and the sections relating to acne, streptococcal infections, influenza, typhoid fever and whooping cough have been largely rewritten, while the composition of the following vaccines has been altered: acne and mixed acne, antiseptis (mixed staphylococcus and streptococcus), and whooping-cough.

PENIS CAPTIVUS.

DR. J. R. W. STEPHENS (Withington, Manchester) writes: I have been asked to report the following two cases as being of interest: (1) During the latter part of 1918 I was called to see a warrant officer, R.N., aged about 54. The penis was enormously swollen and oedematous. There was no pain and no gangrene. The bladder was moderately full. The cause was an ordinary gold wedding ring. His explanation was that his wife had put it on him during the afternoon whilst he was asleep in a chair. It was possible to insert a director under the ring, but a Gigli's saw not being available, the man was sent to hospital, where the ring was removed; he made an uneventful recovery. (2) On March 31st, 1921, at 3.30 a.m., an unmarried man, aged 26, called, stating he was "in great trouble." He was found to be a case of "penis captivus" in the orifice of a large stone hot-water bottle, which still contained warm water. It was not possible to withdraw the organ, which was tightly constricted at its proximal end. With an ordinary nail hammer the bottle was broken by the second blow, and the distal end of the penis found to be swollen and oedematous. A third blow from the hammer removed the constriction, and the penis returned to normal, except for slight bruising, in two days. In this case also there was no complaint of pain.

VACANCIES.

NOTIFICATIONS of offices vacant in universities, medical colleges, and of vacant resident and other appointments at hospitals, will be found at pages 33, 36, 37, 38, 39, and 40 of our advertisement columns, and advertisements as to partnerships, assistantships, and locum tenencies at pages 34 and 35.

SCALE OF CHARGES FOR ADVERTISEMENTS IN THE BRITISH MEDICAL JOURNAL.

	£	s.	d.
Six lines and under	0	9	0
Each additional line	0	1	6
Whole single column (three columns to page)	7	10	0
Half single column	3	15	0
Half page	10	0	0
Whole page	20	0	0

An average line contains six words.

All remittances by Post Office Orders must be made payable to the British Medical Association at the General Post Office, London. No responsibility will be accepted for any such remittance not so safeguarded.

Advertisements should be delivered, addressed to the Manager, 429, Strand, London, not later than the first post on Tuesday morning preceding publication, and, if not paid for at the time, should be accompanied by a reference.

NOTE.—It is against the rules of the Post Office to receive *poste restante* letters addressed either in initials or numbers.

A British Medical Association Lecture

ON

THE EARLY DIAGNOSIS OF ACUTE ABDOMINAL AFFECTIONS.

BY

W. McADAM ECCLES, M.S., F.R.C.S.,
SURGEON TO ST. BARTHOLOMEW'S HOSPITAL.

To the physician belong acute thoracic affections, to the surgeon belong acute abdominal affections, to the general practitioner, in their early stages, belong both, and with him lies the responsibility of diagnosis, and decision as to the line of prompt treatment.

Acute abdominal affections are generally surgical emergencies, but not always and necessarily conditions requiring operative measures, though to be viewed from the first with the possibility of surgical treatment always in mind. Hence it is that an early, rapid and decisive diagnosis is of the utmost importance for the saving of human life.

An old teacher of mine, the late Dr. Samuel Gee, was insistent that in order to diagnose aright it was needful for the physician—and the surgeon, and still more the general practitioner—to be acquainted with the several conditions which could be present in any given case, for without such knowledge accurate diagnosis was impossible.

Acute abdominal conditions vary much, and it is essential for diagnosis to have a clear mental picture of each one which may be present. It is convenient, therefore, to tabulate the most frequent, with their percentage frequency, as follows:

1. Acute appendicitis	70.7 per cent.
2. Intestinal obstructions	18.1 "
3. Perforations	7.2 "
4. Cholecystitis	2.4 "
5. Torsion of pedicles	1.1 "
6. Acute pancreatitis	0.5 "
	100 "

In addition to the above conditions there are two other groups which have to be borne in mind—namely, the colics and poisonings.

In the adult female three other conditions have to be thought of—namely, rupture of ectopic gestation, acute salpingitis, and acute inflammation of the uterus, such as follows septic infection in criminal abortion.

Lastly, acute basal pleurisy or pneumonia, or even the pain prior to the vesicular eruption in "shingles," may simulate an "acute abdomen."

There are certain features which are common to every case of "acute abdomen." Two of these stand out prominently—namely, "acuteness," and, if one may be allowed to coin the word, "abdominalism."

Acuteness is evidenced by sudden onset and rapid development of signs and symptoms.

Abdominalism is evidenced by the fact that the abdomen is obviously the site of the lesion.

Every one of the conditions tabulated above has a sudden origin and commencement and its progress is rapid, so that within a few hours the patient passes into a serious state.

The fact that the abdomen is the seat of the mischief is apparent very soon to the experienced observer. The patient may present the "abdominal facies"; he looks "anxious," and his anxiety is due to the intensity of his abdominal symptoms. The pulse steadily increases in rate, but its rapidity is due to the distant irritation present in the abdomen, and bears no real relation to the patient's temperature. The patient vomits because the stomach is reflexly or directly disturbed. The temperature rises because of inflammation, or falls because of collapse. But all these general signs and symptoms are dependent upon and overshadowed by the actual abdominal changes.

Abdominal pain, and generally tenderness, is present in nearly every case, varying in intensity in relation to the individual and the lesion. The position of the pain may be an indication as to the viscus which is at fault. It is to be remembered, however, that pain also may be referred—for instance, appendicitis in its early stages frequently gives rise to uneasiness or pain at or near the umbilicus,

and too much reliance must not be placed on pain at "McBurney's point."

Tenderness is a valuable sign, particularly if obtained when the patient's attention is distracted. I often try and get the patient himself to detect the tenderness by asking him to "prod" his abdominal wall with his finger, commencing well away from the point where I suspect the lesion, and watching his face as he approaches the region beneath which lies the offending viscus.

Rigidity of the muscles of the ventral abdominal wall is a most valuable sign, and rigidity localized to a particular area often indicates that the mischief lies deep to the wall in that spot.

To reiterate, the characteristic signs and symptoms of an "acute abdomen" are: Sudden onset, abdominal symptoms, anxious expression, rising pulse rate, often an attack of vomiting, sometimes repeated, temperature out of relation to pulse rate, abdominal pain, often tenderness and rigidity of the muscles of the ventral abdominal wall. When a patient presents all these signs and symptoms together, the case is one which may be classed as a surgical emergency.

Each of the conditions which are the causes of an "acute abdomen" has certain peculiarities of its own, and therefore has to be reviewed separately.

1. *Acute Appendicitis.*

There can be no doubt that the actual number of cases of acute appendicitis is on the increase, and over 70 per cent. of acute abdominal disease is due to this lesion. Further, every case is a serious danger. Thirdly, each case should be diagnosed and treated early. Lastly, the mortality from acute appendicitis is still far too high, chiefly because of delay in diagnosis and treatment.

A typical case of appendicitis as a rule presents but little difficulty in early diagnosis. There is a sudden onset, pain in the abdomen, frequently near the umbilicus, not at "McBurney's point," an attack of vomiting, a steady rise in pulse rate up to, perhaps, 120 or more in a child, temperature also rising, but not in proper relation to pulse rate, tenderness over the lower right half of the abdomen, with marked rigidity of the lower segment of the right rectus. If the case is allowed to progress until there is perforation of the wall of the appendix or gangrene of part or whole of the structure, the signs and symptoms become progressively more severe, owing chiefly to the involvement of the peritoneum and a toxæmia.

A word or two as to the examination of the patient. He feels ill, and is anxious about himself, often suspecting appendicitis, and imbued with the horrors he has heard concerning the disease. Therefore the utmost tact and care in examination is needed. Never approach the abdomen with cold hands. Always palpate the sound, left, side first. This gives confidence to the patient, and a standard with which to compare the right side. Never omit to make a rectal examination, but again this must be done with the utmost gentleness.

Having come to the conclusion by examination that the appendix must be suspect, it is desirable to determine if possible where it lies. Most commonly it is placed on the inner side of the caecum and upwards when tenderness is great at "McBurney's point," otherwise over the brim of the pelvis, when micturition may be disturbed, and rectal examination detects tenderness on the right side of the pelvis; or it is running "north" behind the caecum and ascending colon, and bimanual palpation often gives a clue to its presence here. Wherever the appendix may lie, once diagnose it as inflamed, the sooner it is removed the better. To wait for perforation and the formation of a localized abscess is to lose precious time, though perhaps not a precious life. To allow perforation or gangrene to occur, and general peritonitis to follow, is almost criminal. Better to explore even when in doubt than to wait until almost all hope of saving life is past. The tragedies which occur from "wait and see" rather than "look and see" are indeed pathetic.

To recapitulate, 70 per cent. of acute abdomens are due to appendicitis. A sudden onset, severe pain often near the umbilicus, one attack of vomiting, a rising pulse rate, out of proportion to the rise in temperature, and rigidity of the lower half of the right rectus, are sufficient to diagnose appendicitis in its early stage and to call for operation at once.

2. Intestinal Obstructions.

Exclude strangulated hernia at any of the ordinary hernial sites. Obturator hernia is difficult to diagnose; but then it is a rare condition. Internal strangulation and intussusception are the two commoner forms of intestinal obstruction within the abdomen. In both the onset is sudden, pain is marked, and vomiting occurs. In internal strangulation the vomiting is repeated, becomes more urgent, and nothing except removal of the strangulation will relieve it.

In intussusception the vomiting is not so urgent. In strangulation there is "absolute constipation," no passage either of flatus or faeces. In intussusception there is the typical evacuation of blood-stained mucus. In both distension may be an early and prominent sign. In strangulation the pulse rate rises and the temperature falls; in intussusception the same may occur. In intestinal obstruction due to a volvulus a tumour may be felt, generally in the left iliac fossa. In intussusception a tumour may be felt through the abdominal wall, and usually near the umbilicus.

The causes of intestinal obstruction are many, the signs and symptoms of the lesion are similar and as a rule quite characteristic, and the treatment may be summed up in the one word—Operation.

To delay is dangerous and may be fatal; to explore early will not only confirm diagnosis but will generally promote the cure of the patient.

3. Perforations.

Perhaps nothing gives rise to an "acute abdomen" than the perforation of a hollow viscus. The stomach, the duodenum, the appendix, and the gall bladder may all give way, and their contents pass into the peritoneal cavity, producing the most alarming signs and symptoms.

To take a typical case of the perforation of a duodenal ulcer in a male. He is at work when a sudden agonizing pain seizes him in the upper half of the abdomen. He is doubled up, and gasps for breath, because his diaphragm will not descend. He assumes the horizontal position and vomits. When now examined he appears most anxious, his pulse is small and rapid, there is still much pain in his abdomen, the whole of the ventral abdominal wall is rigid, and particularly the upper half of the right rectus. Even upon the foregoing signs and symptoms the practitioner is quite warranted in diagnosing a perforation, and preparations should be made for an immediate operation. Again, it is much better to explore than to wait for advanced signs, such as loss of liver dullness, evidence of free fluid in the abdomen, and signs of peritonitis.

4. Cholecystitis.

There is often a history of attacks pointing to gall stones, sometimes with a previous jaundice. As a rule the onset of symptoms due to an acute inflammation of the gall bladder is rapid: some pain in the right hypochondrium, pain referred in some cases to the right scapular region, vomiting, a steady rise of pulse-rate, with a rise of temperature which may be rapid with a rigor, and muscular rigidity in the upper half of the right rectus. A tumour may be palpated near the right ninth costal cartilage where it joins the eighth. This tumour moves downwards with inspiration, and its dullness is continuous with the hepatic dullness. If all these points are present a sure diagnosis can be made, and that early, and a prompt operation will save life.

5. Torsion of Pedicles.

Various structures within the abdomen may possess pedicles. If the pedicle of any tumour or organ becomes twisted there is immediately interference with the circulation of blood in the attached structure.

The following are some of the intra-abdominal torsions which may occur:

- (1) Ovarian cyst.
- (2) Subperitoneal uterine fibroids.
- (3) "Floating" kidney.
- (4) Wandering spleen.

Of these, the twisting of the pedicle of an ovarian cyst is far the most common. If this happens suddenly, a condition which may aptly be called an "acute abdomen" follows.

The history is not infrequently that of a young or middle-aged woman, who has noticed little if anything wrong with her abdomen previously; while alighting from a bus she is suddenly seized with severe pain in the lower part of the abdomen, associated with vomiting and all the signs of shock. The pulse rate increases, but its force is feeble. Examination of the abdomen reveals a swelling, tender on pressure and dull on percussion. Bimanual pelvic examination confirms the presence of an ovarian cyst, and the symptoms show that its pedicle is twisted. A somewhat similar condition may occur as the result of a twist of the pedicle of a subperitoneal fibroid of the uterus, but the symptoms are not nearly so acute.

A "floating" kidney is a kidney which has a congenital mesonephron, and the organ can float in the abdominal cavity like any other organ possessing such a peritoneal investment. Sometimes its pedicle may be twisted, and very acute symptoms result therefrom. A "movable" kidney is one which moves up and down in its bed behind the peritoneum. If its mobility is sufficient its pedicle may become kinked, and a "renal crisis" may occur. This comes on suddenly with acute abdominal pain referred to the lumbar region of the affected side. The patient vomits, and the pulse rate rises, and although the temperature may be a little high, the pulse is higher than the temperature would warrant. The enlarged kidney may be felt as a tender lump, and very little urine is passed. A spleen is very rarely so mobile as to allow of a twist of its pedicle.

6. Acute Pancreatitis.

It is the so-called haemorrhagic variety of inflammation of the pancreas which gives rise to symptoms of an "acute abdomen." The lesion is due to a rapid infection of the pancreatic tissue via the duct, or possibly through the blood, by a streptococcus. The onset of the symptoms is sudden, so sudden that the patient is *hors de combat* in a few minutes. This is probably due to the loss of blood into the pancreatic tissues producing a profound shock similar to a blow on the "pit of the stomach." There is abdominal pain, referred to the epigastrium at first, and soon to the back in the lumbar region. Vomiting occurs, but is not persistent. The pulse rate quickens and the volume of the pulse is less. The temperature may fall while the pulse goes up, but later there is a rise of temperature. A very characteristic sign occurs even in the early stages, and it is one which serves to distinguish this cause of an "acute abdomen" from all the others. The patient's face and extremities are distinctly cyanosed, and there may be some dyspnoea. Further, there may be a slight icteric tinge of the conjunctivae. Loewe's adrenaline test may be of help, but all this type of test serves to delay abdominal exploration, which not only confirms the almost certain diagnosis of the lesion, but also is the only means of saving the patient's life.

Colics.

We have now reviewed the common causes of really acute abdominal conditions, but it has to be confessed that there are certain other conditions which, while they may give the patient very severe distress, nevertheless do not place his life in danger. I refer to what may be termed "the colics"—intestinal, renal, or biliary.

We have all seen patients suffering agonies from each of these spasmodic contractions of unstriated muscle, but very few of us have ever seen death occur primarily on account of any one of them. Intestinal colic is very common, and unless very severe it does not produce a condition which really simulates an "acute abdomen." There is one sign which is of great importance, and that is that pressure upon the abdominal wall tends to relieve the patient's pain. Of none of the lesions producing an "acute abdomen" can the same be said. It is so characteristic that pressure causes pain in the serious condition, and does not do so, but actually relieves it, in simple colic, that if there is tenderness on pressure associated with any other symptoms of an "acute abdomen" it is better to diagnose the presence of a lesion which is a menace to life.

Poisoning.

Poisonings occur and simulate an "acute abdomen." There is generally, however, a definite history of the intake or absorption of an irritant substance which helps the diagnosis.

Gynaecological Conditions.

I need only refer again to the three conditions: rupture of an ectopic gestation, acute salpingitis, and acute septic metritis, and to say that when the patient is an adult female one must always bear them in mind.

In conclusion, gentlemen, it is a matter of congratulation that while the causes of an "acute abdomen" are not apparently on the wane, the gravity of the condition is becoming more and more recognized, and its early diagnosis, which is a matter of supreme value, arrived at in a much larger number of instances. We must look forward to the day when all "acute abdomens" will be recognized within the first few hours of their sudden onset, and surgical treatment carried out with the least possible delay.

A NOTE ON INJURIES TO THE FEMALE URETER.

BY

A. LEYLAND ROBINSON, M.D. LOND., F.R.C.S. ENG.,
HONORARY ASSISTANT SURGEON, HOSPITAL FOR WOMEN,
SHAW STREET, LIVERPOOL.

KELLY AND BURNAM¹ state that injury to the ureter is the most common complication of pelvic surgery, whilst Burney² has collected sixty-two such cases, of which sixteen were bilateral; probably the bulk of such accidents are either overlooked or not reported. The course of this duct and its surgical relationships make it peculiarly liable to injury in women. Certain anatomical points are worthy of notice:

1. The female ureter enters the pelvis behind the infundibulo-pelvic fold and its contained vessels, and may readily be injured during ligation of the ovarian artery, particularly if the fold is put on the stretch and the needle passed close to the pelvic wall.
2. Curving forwards below the pelvic brim the ureter lies above the suspensory ligament of pelvic fascia (Paterson's)³ in close contact with the posterior leaf of peritoneum an important and constant surgical landmark even in fat subjects.
3. At the base of the broad ligament the duct is crossed in front by the uterine vessels, and not uncommonly has an additional artery behind it (an accessory uterine or vaginal branch).
4. The ureter perforates the parametrium at a distance of about three-quarters of an inch from the cervix, where it is enclosed in a fibrous tunnel (the so-called ureteric canal), and surrounded by veins derived from the vaginal and vesical plexuses.
5. The terminal part has variable relationships, as shown by Heller,⁴ but it may be said to lie on the roof of the lateral vaginal fornix.

The possibility of injury is always present when ligating the ovarian and uterine vessels, and when dividing the attachments of the broad ligaments, cervix, vagina, and bladder. This risk is reduced to a minimum in ordinary cases if the operator (1) works entirely within the course of the duct; (2) avoids the pelvic wall when tying the infundibulo-pelvic fold and ovarian vessels; (3) divides the broad ligament close to the cervix; and (4) pushes the bladder well down before opening the vagina.

In Wertheim's operation, however, full exposure of both ureters is essential, and such dissection may be the easiest way to avoid injury in other cases, particularly where burrowing fibroids and intraligamentary cysts have led to anatomical dislocation, and perhaps distension from pressure. At all times free bleeding may occur to obscure the relationships and increase the likelihood of the ureter being mistaken for a vessel or band of peritoneum. Identity must be established by one or more of the following tests:

1. Kelly's vermicular contraction test—that is, waves of peristalsis produced by stroking the ureter pathognomonic when seen.
2. Absence of pulsation.
3. Consistency and thickness of wall: the ureter is much thicker and harder than a vein and thicker and softer than an artery.
4. Familiarity with surgical landmarks, especially attachment to the posterior leaf of peritoneum (described above); no blood vessel hugs the peritoneum in this way.

Results of such injuries may be summarized as follows:

Bilateral.

- (a) Double section; leakage with general infection and death.
- (b) Double ligation, with anuria; fatal if unrelieved. Treatment consists in either releasing or implanting one or both

ureters, or in draining the kidneys by nephrostomy. Two typical cases may be quoted of double ureteric ligation. Caulk and Fischer⁵ record a case operated on successfully after eight days' suppression in which double nephrostomy was performed. It is interesting to note that fifty-nine days later complete canalization of the ligated ureters had taken place, and all the urine was being passed via the bladder. Cuthbert Lockyer⁶ mentions a similar case in which he implanted one ureter into the bladder and removed the opposite kidney with complete recovery.

(c) In those cases, undoubtedly rare, in which only one kidney or normal kidneys and only one ureter are present, a single injury is functionally a double one.

Unilateral.

- (a) Section, with leakage; acute infection.
- (b) Partial section, with subsequent leakage and fistula formation.
- (c) Ligation, atrophy of kidney with or without symptoms of renal insufficiency (acute or chronic uraemia).
- (d) Ligation, reflex suppression with complete anuria.

The ideal treatment (as in bilateral cases) is immediate repair or implantation, but usually such manipulations are difficult and increase shock by prolonging the operation; they may also be followed by secondary contracture and obstruction at the site of repair unless there is a complete absence of tension.

Simple ligation of both ends of the cut ureter has been practised deliberately by many surgeons, generally without harmful sequelae if the remaining kidney is healthy. Atrophy of the affected kidney is preceded by distension but no true hydronephrosis develops; pain in the loin and tenderness on palpation with tachycardia are the commonest symptoms, often so trivial as to be overlooked by surgeon and patient. If the remaining kidney is unhealthy and unable to take on additional work uraemic symptoms appear. Rarely complete anuria may follow from reflex suppression, as the following case illustrates:

Mrs. D., a widow, aged 51, was admitted to Shaw Street Hospital for Women, March 20th, 1920, with a history of eighteen months' excessive bleeding at the periods and slight recent leucorrhoeal discharge. She also complained of shortness of breath on exertion and some loss of flesh.

The cervix uteri was thickened and contained a nodule that bled readily on examination; it was therefore decided to remove the uterus by Wertheim's method for early carcinoma. This was carried out on March 22nd. The left ureter was cut at the pelvic brim when ligating the ovarian vessels. Implantation being considered impracticable, both ends were tied off and covered with peritoneum. Otherwise the operation presented no unusual features, and the patient's general condition immediately afterwards was quite satisfactory. The following is an extract from the notes of the case:

March 23rd (day after operation): Patient restless; slept little; a good deal of pain and a little vomiting. Temperature 99.4; pulse 92; 3 ounces of urine passed during night. March 24th: Less pain; no vomiting; has passed flatus and is retaining salines. Temperature 100.8; pulse 104; 9 ounces of urine passed yesterday, and 12 ounces this morning. March 25th: Suppression of urine since 7 p.m. last night; bladder empty; hot packs ordered with salines andomentations to the loins; pilocarpine 1 10 grain, pulv. jalapae co. 30 grains. 6 p.m.: Bladder still empty; patient sweating freely; theocin 5 grains two-hourly. March 26th: Suppression continues; oedema of face, ankles, and hands; irregular breathing during the night; patient quite clear mentally; complains of severe headache; slight diarrhoea; no vomiting; no muscular twitchings; moderate cyanosis. Temperature 100.8; pulse 120.

I saw her when anuria had persisted for forty-one hours; there had been no response to conservative measures; the cyanosis was marked and the general condition alarming; fortunately there was no doubt as to the patency of the right ureter; I therefore decided to decapsulate the right kidney. This was done under light ether anaesthesia. The kidney was quickly delivered and found to be deeply congested, dark blue in colour and hard in consistency, but otherwise showed no sign of disease. After incision of the capsule the edges were quickly separated by bulging renal substance, demonstrating an obviously increased intrarenal tension. The capsule was stripped up and excised and the wound closed with one layer of sutures. The whole operation lasting fifteen minutes. Three hours later 3½ oz. of urine were removed by catheter; 62 oz. were passed in the following eighteen hours and altogether 4½ pints in the forty-eight hours succeeding operation.

Convalescence was uneventful, and in spite of a mild attack of cystitis and parotitis the patient left hospital on April 27th, 1920, looking and feeling well. She had no symptoms of renal insufficiency and MacLean's test gave a urea excretion of 2 per cent. Polyuria was absent; the specific gravity was maintained above 1015, whilst the average amount of urine passed daily for thirty days was 28 oz., an amount stated by Foxwell⁷ to be normal for a healthy woman. In view of these findings it was not considered necessary to estimate the urea blood content or to use colorimetric methods. At the present date (twelve months later) she remains quite well.

This case illustrates certain points in the pathology of anuria and emphasizes the important part played by vascular changes in the production of this condition. It must be noted that three chief factors are concerned in producing diminution of the urinary secretion:

1. Circulatory (spasm or thrombosis), the result of (a) direct action on the vessels of bodies such as turpentine; (b) indirect action of poisons or toxins acting through the vasomotor system.

2. Epithelial changes, either (a) primary, the result of toxins (for example, diphtheria), or (b) secondary to vascular changes or nervous trauma.

3. Obstruction to the tubules, which may be (a) extracapsular—renal calculi—or other gross pressure on or in the ureters from bilateral neoplasms, or untreated injuries, or (b) intracapsular—arising from purely vascular changes, inflammatory exudates (for example, acute nephritis), or possibly degenerative lesions of eclampsia).

Probably several of these factors are in action at once, but there is a type of case in which the kidney is hard and congested and gapes through the split capsule; here intracapsular or intrarenal pressure is playing the chief part by crushing the renal epithelium against the unyielding capsule. This pressure can be relieved by decapsulation or by various medicinal methods. The value of veratrine (recently emphasized by Bourne⁸) and morphine in eclampsia is probably due to their effect in lowering the general blood pressure and so reducing intrarenal tension. Similarly methods which were said to diminish toxæmia (purgatives, diaphoretics) may act in the same way by depleting the circulation. It is unfortunate that decapsulation should always be associated with the name of Edebohls, who practised it almost entirely for chronic nephritis. He maintained that new vessels were formed between the denuded kidney and its fatty capsule, and that this anastomosis, by increasing the renal circulation, promoted the absorption of inflammatory tissue and led to the regeneration of renal epithelium. Many observers have failed to confirm his findings; as Boyd and Beattie⁹ point out, such adventitious vessels may be formed, but they probably fail to do more than compensate for the capsular vessels ruptured by the operation. The real indication for decapsulation is an acute increase in intrarenal pressure; this is not seen in the kidney of chronic interstitial nephritis, in which the effects of pressure are neutralized by protecting bands of fibrous tissue.

Harrison,¹⁰ the real pioneer, who anticipated Edebohls by two years, was clearly familiar with this condition, for he describes the hardness of the kidney and compares the increased tension with that seen in the eye in glaucoma. It is further interesting to note that his first three cases were distinctly medical or toxic in type, and due to scarlet fever, influenza, and nephritis from cold respectively. Clifford White¹¹ has advanced important evidence in favour of the presence of increased intrarenal pressure and the value of decapsulation in eclampsia. There is, however, a tendency to regard suppression as a purely toxic condition, and if not unsuitable for operation, at least only suitable when all conservative measures have failed. No doubt the vascular changes are greater in some cases than others—for example, Rose Bradford¹² states they are marked in the acute nephritis of scarlet fever and slight in that of diphtheria. But although toxæmia may be the chief pathological agent, vascular changes are rarely absent; they lead to further impairment of function, and establish a vicious circle in which a rising intracapsular pressure is the important pathological mechanism.

It is, of course, essential to treat toxæmia and give conservative remedies a fair trial, but it is unfair to expect decapsulation to be useful in the terminal stages when thrombosis and necrosis have occurred and the renal epithelium is irretrievably damaged. I would urge that in any acute suppression of urine (partial as well as complete) where the patient is not responding to treatment an early decapsulation should be seriously considered.

REFERENCES.

- ¹ Quoted by Caulk and Fischer, *Surg., Gyn. and Obstet.*, vol. xxx, p. 343. ² *Trans. American Urolog. Assoc.*, 1919. ³ *Journ. Anat. and Physiol.*, vol. xli, p. 102. ⁴ *New System of Gyn.*, vol. iii, p. 644. ⁵ *Surg., Gyn. and Obstet.*, vol. xxx, p. 343 et seq. ⁶ *New System of Gyn.*, vol. ii, p. 246. ⁷ Quoted by Box, *BRITISH MEDICAL JOURNAL*, March 13th, 1920. ⁸ *BRITISH MEDICAL JOURNAL*, May 29th, 1920. ⁹ *Edu. Med. Journ.*, 1905, p. 357. ¹⁰ *Lancet*, Aug. 3rd, 1901. ¹¹ *Proc. Roy. Soc. Med.*, 1919, vol. xii. ¹² Clifford Allbutt's *System*, vol. iv, Part I.

A Lecture

ON

THE AXIS OF ASTIGMATISM.*

BY

N. BISHOP HARMAN, M.A., M.B. CANTAB., F.R.C.S. ENG.,
SENIOR OPHTHALMIC SURGEON TO THE WEST LONDON HOSPITAL
AND THE BELGRAVE HOSPITAL FOR CHILDREN.

RECENTLY I had an inquiry from a practitioner engaged in eye work at a school clinic in South Africa, asking advice on the best and most accurate method of determining the axis of a cylinder necessary for correcting an astigmatic error of refraction; the same question has been put to me this week. I therefore propose to deal with this practical point.

First, we must consider the mental attainments of the patients whose visual defects we propose to diagnose and correct. Our patients are children—school children—their ages run from, say, 5 to 14 years. Those of the earlier years it may be taken will certainly not have developed any notable powers of observation; and since our working arrangements must be adapted to suit the conditions of the feeblest member of the clinic, it follows that the whole of the refraction work done for children must be objective and not subjective. It is no use asking a child whether this or that glass is better than another, or what difference this lens of a fraction of a dioptré makes to clearness of vision. The child cannot be expected to tell. Those of you who wear glasses will know how difficult it is to determine between the advantages of two slightly different lenses when used to view the test type, and how much more difficult it is to set a cylindrical lens of low power exactly in the best axis. If this be so in the case of an educated adult, what can you expect of a child? Subjective tests are of little or no value in a children's clinic, and no use should be made of them except to obtain a record of visual acuity under given conditions, and even then the record must be used with due caution, bearing in mind the strangeness of the conditions of the examination to the child, and the likelihood of variations in understanding and intelligence.

No man is fit to take a share in this work of a school clinic who is not a master of the art of retinoscopy. That is the one test of competency for this work. A knowledge of external diseases and their treatment is necessary; ability to use the ophthalmoscope and determine fundus conditions is needed; but, seeing that nine-tenths or more of the work of these clinics will be to determine the cause of a suspected or known defect of visual acuity, competency in the art of retinoscopy is the outstanding requirement. The worker must be such a master of the art that he can, by the use of his mirror and lenses, both discover all the details of the refraction and judge from his results what will be the most appropriate glasses to order in any given case. Short of possessing this mastery of the art, there is no place for him in a school eye clinic.

Further, a school clinic is not the place in which to acquire this mastery. It can only be obtained by regular and assiduous work with critical patients. To the seeker after this knowledge I would advise a course of practice with young adults—those whose faculties are well developed, and who can give good responses to subjective tests; and he should choose those for whom the suppression of the power of accommodation for a few days by the use of atropine will be no detriment to their work. There will be found plenty such in any ophthalmic clinic of a teaching hospital, and with their aid he will be able to check his capacity for retinoscopy.

The following is a plan which may be recommended:

1. Ascertain the visual acuity of each eye of your test patient on the usual Snellen's types.
2. Make an attempt to improve any defect of vision by the use of trial lenses.
3. Examine the refraction by retinoscopy without the use of a mydriatic.
4. Instil an oily solution of homatropine and cocaine, 2 per cent. of each. After an interval of one hour do another retinoscopy; and then ascertain the visual results obtained with the correction arrived at by the retinoscopy.
5. Order an oily solution or ointment of atropine and cocaine, 1 per cent. of each, for use thrice daily for two days. Then

* Delivered at the West London Post-Graduate Coll'ge.

repeat the retinoscopy, and the subjective test with the correction worked out by retinoscopy.

6. Finally, a week later the subjective test should be repeated before glasses are ordered.

The worker must keep a note-book in which to enter a record of each step of the examination of each patient in full detail, with comments on any difficulty met with. When he has followed out this programme with a score or two of intelligent patients, and studied the results after each day's work, he will be in a position to judge of the value and accuracy of his work; and he will also have obtained valuable knowledge of the differences between subjective tests of an eye of unknown condition, retinoscopy with and without a mydriatic, and the differences, if any, between quick and slow acting drugs, and finally of subjective tests with all the available data before him. Only by a continuous course of practice such as outlined here, in which he can check his objective work by the subjective examination of critical patients, can he cultivate a mastery of objective methods and free himself from the thrall of reliance upon subjective responses.

I have written an account of the methods of retinoscopy that I find best to use and teach, so that I propose here to deal only with one point—the best method of finding the axis of astigmatism by the use of the retinoscopy mirror.

Astigmatism is due to an inequality of the refractive index of the optical combination of the eye; the inequality can be seen and measured by retinoscopy. It may be obscured at first examination by the presence of a spherical error; as that error is corrected the fact that there is more error in one meridian of the eye than in another will be revealed. The revelation of the defect is sometimes, when the error is high, quite dramatic. The light reflex from the eye may assume the appearance of a pillar of fire. The pillar may be erect, running vertically across the pupil, or it may have an inclination or slope from the perpendicular; it may even be horizontal. It is the observance of this inclination that gives the axis of the astigmatism.

Take a plus cylinder of six or seven dioptres, look through it at a distant circular light, such as may be obtained by placing a screen pierced with a half-inch hole before an electric glow lamp; the circle of light will be seen to be distorted into a hue, and as the cylinder is slowly rotated before the eye the line of light will turn also; it will only need a method of marking the inclination of this line of light to register the position of the cylinder held before the eye.

The axis of a cylinder is recorded by noting the position it takes on a circle or half-circle marked in degrees. Most students are familiar with certain standards of measurements; probably all could mark on paper with fair accuracy the measure of an inch, a centimetre, or millimetre; most women can judge a yard with surprising skill. We do these things because we are familiar with the measure, and associate it unconsciously perhaps with some concrete object. But you are not familiar with the degrees of a circle, for this measure does not often enter into everyday life. To obtain this familiarity I would refer you to something you know well—the familiar clock face; the hour marks on the face will give the salient points of the degrees of a circle.

If we take the hour mark of IX as 0 and III as 180, then VIII will be 30, VII 60, VI 90, V 120, IV 150. Apply this observation by association to the judgement of the inclination of the line of light seen in retinoscopy of astigmatism. Note the time that would be indicated if the line of light were the outstretched hands of the clock, if it indicated five minutes to five o'clock the inclination in degrees would be 120. With practice, and a constant cross-reference between time of the clock and degrees of the circle, the worker will be able to read off the axis of an astigmatism from the eye itself as accurately, and often more accurately, than can be given by a critical patient in subjective examination.

Practice in direct observation should be checked by reference to the markings of the degrees on the cell of the trial frame. There are two useful methods of doing this:

1. Take a thin blackened disc of metal the size of a trial lens, bore through the centre a 10 mm. hole, and mark the diameter on the remaining part of the disc by a line of white paint just broad enough to be seen at one metre. Slip this disc into the cell of the trial frame so that the patient's pupil can be seen through the hole. Note the line of light due to the astigmatism and its inclination, and estimate the axis in degrees. Then rotate the disc in the trial frame until the painted white line is in continuity with the line of the astigmatism, note the position of the paint line to the marking on the trial frame. If the two observations, the direct observation and the position of the paint line, agree, you will have done well.

2. Correct the spherical part of the error of refraction by the use of spherical lenses, when the astigmatism is revealed

correct this by the use of cylindrical lenses, marking each cylinder in the cell of the frame so that its axis coincides with the line of the astigmatism. If now the spherical correction be slightly altered so as to leave half a dioptre of hypermetropia, the light reflex due to this spherical error should move equally in every direction, and without wobble or sign of obliquity with each movement of the mirror. This is a most valuable and delicate test.

Practice of these three methods, comparing direct observation with the findings obtained with the aid of disc or cylinders, will show that it is possible in the majority of cases to measure the astigmatism both in amount and axis by the use of the mirror and spherical lenses alone; and the use of cylindrical lenses may be reserved for the few cases of real difficulty.

A concluding note may be made on the method of recording the axis of cylinders ordered in prescriptions. Unfortunately, there are many markings in use. Examine a dozen trial frames of different makes and as many prescription forms: the variations found will be striking. An attempt has been made to obtain an international agreement, and the form arrived at can be appreciated by reference to the clock face. For each eye, right and left, the degree markings that correspond with the hour marks on the clock face are 0 at IX o'clock and 180 at III o'clock. Since this marking is obtaining a wide measure of acceptance it is worth while learning it, for if you use another it is likely your prescription will be transcribed by the optician, and errors may occur in transcription. In any case always mark the axis graphically as well as numerically, then the possibilities of error will be reduced to the minimum.

REFERENCES.

Aids to Optimal Vision, sixth edition, 1919, London, Baillière, Tindall, and Cox.

A NOTE ON LYMPHADENOMA.

BY

GEORGE J. LANGLEY, M.D. LOND., M.R.C.P.

ASSISTANT PHYSICIAN SALFORD ROYAL HOSPITAL, PHYSICIAN, ARBOATS HOSPITAL, MANCHESTER.

THE following case, which has been under hospital observation almost throughout its clinical course, offers so many points of interest with regard to diagnosis that it may be worth while recording at some length.

G. K., a single man aged 24, had always been healthy except for an attack of scarlet fever at 7 years of age. There was no family history of tuberculosis or any other disease, nor of any other illness in the patient prior to enlistment in November, 1915. He was demobilized in May, 1919, having served two years in France and having been twice in hospital, once with tonsillitis in 1916, and once being invalided home with myalgia in 1917, recovery taking place in six months. After demobilization the patient returned to his civil employment as a grocer's assistant until November, 1919, when rheumatism in his shoulders and back caused him to give up work.

In January, 1920, he became an out-patient at a pensions hospital, but owing to the development of a left basal pleurisy he became too ill to attend. In March, 1920, a swelling was noticed in the right axilla, which quickly disappeared, only to be followed by similar swellings in the left axilla and right side of the neck. The patient became gradually very pale, lost weight, and grew progressively weaker, but was not entirely bedridden till admission to hospital on April 25th, 1920. He then complained of night sweats, and rheumatism in the back, shoulders, and right knee.

Clinical Description.

On admission the patient was pale and wasted, with obvious masses of enlarged gland in the neck. On examination, both sides of the neck and the submaxillary region were full of enlarged discrete glands, very various in size from a pea to a walnut and with little or no perianthitis. Both axillae showed a similar condition and the right epitrochlear gland was as large as a flbert, but the left could not be felt. Both groins showed many enlarged glands extending along Poupart's ligament both above and below it. The popliteal glands could not be felt. There was a large crop of subcutaneous and intra-cutaneous nodules all over the right side of the chest wall, not crossing the mid-line in front nor the posterior axillary line.

behind; some looked slightly inflamed with a hyperaemic apex. They varied in size from a hazel nut to just palpable masses.

The heart showed a cardiac dullness extending upwards to the third costal cartilage and to the right I in. beyond the right sternal edge, the apex beat was in the fifth space in the nipple line, cardiac sounds were feeble, and there was a precordial systolic murmur not conducted. The pulse rate was 116 per minute, regular, but of poor volume and low tension. Chest movements were normal and the breath sounds healthy, except for a slight friction rub at the right base productive of some pain and cough. Percussion resonance was normal, except over the manubrium sterni in front, and behind at the level of the fourth thoracic vertebra on both sides where resonance was diminished.

The liver dullness in the nipple line extended from the sixth rib to the costal margin where its edge was felt to be even, firm, and not tender. Splenic dullness in the mid-axillary line extended from the tenth rib to the tip of the organ, which was just felt below the ribs. In the right iliac fossa a mass of glands was felt resting against Poupart's ligament, and apparently continuous with the mass in the right groin. No other abnormality was detected in the abdomen. All reflexes were found to be normal; the urine was alkaline, specific gravity 1020, and it contained no albumin.

A skiagram showed the right diaphragm slightly raised, the size of the liver and spleen was not determined, the posterior mediastinum was somewhat obscured, probably by enlarged glands.

A blood count gave the following results:

Red blood corpuscles	4,500,000
White blood corpuscles	15,000
Haemoglobin	85 per cent.
Colour index	0.9
Polymorphonuclears	51 per cent.
Small lymphocytes	15 "
Large lymphocytes	22 "
Large hyalines	4 "
Eosinophils	9 "
Mast cells	0 "

My surgical colleague, Mr. Jefferson, kindly removed for histological examination (a) a gland from the left groin and (b) a nodule from the skin of the right chest wall.

On section both tumours showed the typical changes of lymphadenoma, with small giant cells containing three or four deeply-staining nuclei, a large number of eosinophils, and an increased fibrosis.

Throughout the whole illness the patient ran a temperature of about 101° F. at night and normal in the morning, except for about a fortnight in early July, when the temperature remained normal. At no time did he show the typical Pel-Ebstein temperature variation.

The patient was given large doses of arsenic for long periods and regular x-ray exposures. In spite of this, the course of the disease was slowly but progressively downwards. The only time of apparent improvement was during the period of apyrexia in early July. The x-ray treatment produced very considerable results on the glands, those in the neck completely disappearing, while those in the axillae and groins were very materially reduced. On the other hand, the cutaneous nodules were not at all affected and continued to grow slowly, desquamation and redness occurring over the larger ones in spite of protection by cotton-wool. In August a mass appeared at the second left chondro-sternal junction which appeared to rise from bone, and which grew to the size of half a Tangerine orange, being firmly fixed both to bone and skin. A few weeks later a mass appeared at the back of the neck which appeared to arise from the lower cervical vertebrae. In November a nodule the size of a walnut at the right anterior axillary fold broke down and ulcerated, having a crateriform, granulating, hyperaemic surface and a central yellowish slough. About this time a large, indefinite softish mass could be felt in the right lower abdomen which appeared to be an infiltration of the caecum and ascending colon. The liver and spleen became impalpable very shortly after commencing x-ray treatment, and the liver did not again become palpable till definite signs of cardiac failure with ascites and oedema had appeared; it was then firm and tender, but the spleen could not be felt.

The patient suffered much pain throughout the illness. In the chest this was due to transient pleural friction in the region of the liver or spleen. Pain in the long bones was complained of from time to time, but the chief pain was abdominal, although at no time was there any vomiting or bowel trouble. The patient was extremely anaemic throughout and became very emaciated. No symptoms of mediastinal pressure ever occurred. The masses arising from bone never appeared to cause pain. The total duration of the disease was almost exactly a year, death

occurring at the end of November. Unfortunately permission for *post-mortem* examination was withheld.

The changes which occurred in the blood picture are indicated in the following table, with dates:

	May 22, 1920.	Aug. 6, 1920.	Oct. 31, 1920.
Red blood corpuscles	4,560,000	5,100,000	3,100,000
White blood corpuscles	15,000	27,500	32,500
Polymorphs	51 per cent.	69 per cent.	75 per cent.
Small lymphocytes	15 "	10 "	8 "
Large lymphocytes	22 "	6 "	10 "
Large hyalines	4 "	3 "	4 "
Eosinophils	9 "	11 "	3 "
Mast cells	—	—	—
Haemoglobin	85 per cent.	90 per cent.	60 per cent.
Colour index	0.9	0.9	1.0

The interest of this case lies in the difficulty of clinical diagnosis. The growths in the skin suggested at once that the case was not one of lymphadenoma but of lymphosarcoma. The absence of any marked splenic enlargement and the type of fever, which did not conform to the Pel-Ebstein sequence, strengthened the view of its malignant nature. On the other hand, the blood picture and the quite remarkable response to x-ray treatment strongly suggested lymphadenoma. The appeal to histological inquiry—the only possible method of arriving at a conclusion—quickly settled the nature of the disease, but helped not at all in explaining its unusual character.

The recognized occurrence of cutaneous nodules in lymphatic leukaemia added some support to the theory that the case might be regarded as the pre-leukaemic state of leukaemia, but such alteration of the blood picture as did occur was in a direction away from typical lymphatic leukaemia. The occurrence of tumour masses in the bones (manubrium sterni, vertebrae) suggested the possibility of lymphadenoma ossium, but these masses appeared late as an incident in the disease, rather than as the basic fact of it.

The cutaneous masses remained discrete, and did not tend to coalesce. The single mass which ulcerated did not proliferate nor fungate, the process being very slow and apparently more due to pressure than to active growth. All this was very unlike the descriptions of mycosis fungoides. The blood picture corresponded in some measure with the findings of Bunting¹ in lymphadenoma cases, in that it showed a fall in lymphocyte and eosinophile count with a rise in polynuclears as the disease progressed. The occurrence of these tumour masses in skin and bone becomes more intelligible when they are considered in the light of the view put forward by Adami² that they are not to be regarded as metastases, but as hypertrophies arising in the lymphoid tissue of the perivascular sheaths. By this theory their occurrence in any site is explainable.

My thanks are due both to Dr. W. J. S. Bythell for x-ray reports and to Dr. C. E. Jenkins for much pathological help.

REFERENCES.

- ¹ Bunting: *Johns Hopkins Hospital Bulletin*, xxv, 1914, p. 173.
- ² Adami: *Principles of Pathology*, vol. i, p. 740.

A COURSE has been arranged by the London School of Medicine for Women for the instruction of qualified medical women in the treatment of venereal diseases at the Royal Free Hospital, the Elizabeth Garrett Anderson Hospital, and the London Lock Hospital. The course, which will begin on Tuesday, May 17th, at 10 a.m., when Mr. J. E. R. McDonagh, will give an introductory lecture on "Some aspects of the venereal problem," will extend over two weeks, concluding on Saturday, May 28th. The Ministry of Health recognizes attendance at this course as qualifying a medical practitioner who has pursued it to receive free drugs for the treatment of venereal diseases. Qualified medical women who wish to attend the course are asked to send in their names to Miss L. M. Brooks, warden and secretary of the medical school, not less than seven days before the course begins; the fee for the full course will be 5 guineas.

THE PHYSIOLOGICAL COST OF MUSCULAR WORK MEASURED BY THE EXHALATION OF CARBON DIOXIDE.

BY
A. D. WALLER, M.D., F.R.S.,
AND
MISS G. DE DECKER.

The following observations form part of a survey upon which we have been engaged during the last three years, of the physiological cost of muscular work measured by the expiratory discharge of CO₂. The expenses of the inquiry have been in part met by grants received from the Royal Society and from the Medical Research Board, and during the last year from the Industrial Fatigue Research Board. Our results have been reported from time to time in the form of communications to the Royal Society and to the Physiological Society, and during the past year to this JOURNAL and to the Académie Royale de Médecine de Belgique.

These last communications, which are of the nature of reports to the Industrial Fatigue Research Board, have in our view a prospective medical as well as an industrial application, since our method of observation is, we believe, practicable in hospitals under conditions of abnormal metabolism as well as in factories and on the road under normal conditions. The method was described last year in this JOURNAL (April 17th, 1920) for the express purpose of enabling any unskilled observer to acquire and utilize it if so inclined, and need not therefore be redescribed now. The same paper contains the summary account of a week's observation made by Miss G. De Decker at the printing rooms of the BRITISH MEDICAL

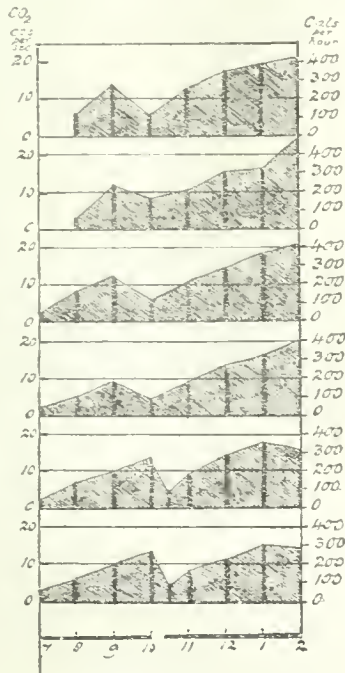

FIG. 1.—Colliers (across cost of labour). (See next Table I.)

JOURNAL upon four compositors, showing as the average rate of energy output (gross) 103 = 2 kilo-calories per man per hour that is, approximately 100 calories per hour (vide table below).

Our communication to the Belgian Academy of Medicine gave an account of the physiological cost of route marching upon four Belgian soldiers under service conditions, and showed as the average rate of energy output (net) 110th cubic centimetre of CO₂ per kilogram body weight per horizontal metre traversed.

Otherwise—if less precisely expressed—an average "fit" soldier (Belgian) marches under service conditions, with a load of 28 kilos, 16 kilometres (nearly 10 miles) in four hours (i.e. 50 minutes marching — 10 minutes rest per hour), at a net physiological cost of 1,000 calories, or 250 calories per hour.

The present communication deals with the energy output (A) of colliers during their work at the coal face; (B) of shoemakers during their work in the factory.

A. COLLIERIES.

Our observations were taken at the Cwm Colliery, near Pontypridd, by courtesy of the Great Western Colliery Company, and our thanks are due to Mr. Rees, the manager, who made arrangements enabling us to take hourly observations upon two colliers, D. O. and H. K.,

The substance of a report to the Industrial Fatigue Research Board.

during their actual work at the coal face in "getting coal" and loading it on trucks. Our procedure consisted in the hourly collection of expired air for 30 seconds: this was

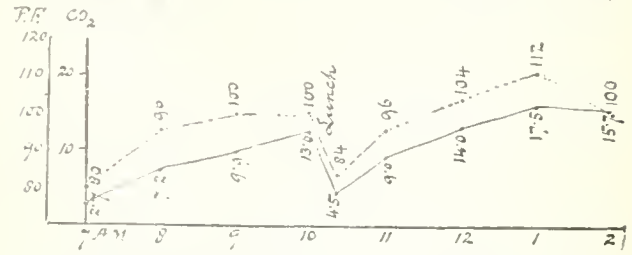

FIG. 2.—D. O. (Friday, October 8th.) Pulse frequency and CO₂ discharge rate, simultaneously at hour intervals during seven hours work at the coal face.

hardly felt as an interruption of work by the colliers, who lent themselves to the proceeding with the utmost goodwill. The work being "piece-work"—that is, the wage

TABLE I. Showing Rate of Pulmonary Exhalation of CO₂ (c.c.m. per second) and Pulse Frequencies of two Colliers at Cwm Colliery during three days' work at the Coal Face—Wednesday, Thursday, and Friday, October 6th, 7th, and 8th, 1920.

Date and Subject.	Time: A.M.					P.M.			
	7	8	9	10	10.20	11	12	1	2
October 6th.									
D. O.	28	60	110	53	—	129	175	190	210
H. K.	—	30	120	78	—	106	152	160	230
October 7th.									
D. O.	25	84	112	60	—	109	140	186	206
H. K.	20	50	90	45	—	94	135	162	220
October 8th.									
D. O.	27	72	99	136	4.5	9.0	140	175	157
H. K.	30	61	103	134	4.1	8.2	116	152	140

From 10 to 10.20 a.m. there was an interval for lunch; on the three day samples were collected at beginning and end of this interval. The pulse frequencies were taken during collection of samples.

Summary.

	Estimated Output of Coal per Man per 7 hours.	Total Cost gross CO ₂ Exhaled in 7 hours.	CO ₂ per hour (gross)	Calories per hour.	
October 6th.	Tons.	Litres.	Gross.	Net.	
D. O.	4.5	313.5	44.8	252	202
H. K.	4.5	315.0	45.0	264	193
October 7th.					
D. O.	4.0	290.3	41.5	245	185
H. K.	4.0	245.9	35.3	207	141
October 8th.					
D. O.	3.5	256.6	35.7	215	155
H. K.	3.5	230.4	32.9	193	127
Average net cost					158

Allowance made for the first hour when no observation was taken.

being dependent on the tonnage got, was practically maximal and constant. Its energy value came out lower than we had anticipated, a fact that must, we believe, be explained as being due to the skilled character of the work of coal getting. A pulse count was taken during each half-minute while the expired air was being collected, the plotted curve of pulse-frequencies proved to be remarkably similar to the plotted curve of CO₂ discharge throughout the day's work, which was from 7 a.m. to 2 p.m., with an interval of twenty minutes at 10 a.m. for "lunch" (bread and cold tea or water; no alcohol). (See Fig. 2.)

The CO₂ figures (c.c.m. per second) and the pulse frequencies for the two colliers—D.O., aged 49, weight 61 kilos, and H.K., aged 43, weight 67 kilos—are recorded in Table I.

B. SHOEMAKERS.

By courtesy of Mr. Francis J. Clark we have taken the following hourly readings at the boot and shoe factory of Messrs. C. and J. Clark, at Street, upon two male operatives at work in the "finishing room." The work there is reputed to be the hardest in the factory, and by the workmen themselves is commonly termed "donkey work." In our view, however, it must be classified as "light work." It is carried out under excellent conditions of light and ventilation as "piece-work"—that is, there is no liability to lose time—in a room 220 ft. by 120 ft. by 12 ft., intended to accommodate 400 workmen (64 square feet of floor space per man), but in which there are at present only half that number. By reason of the actual slackness of trade these men are working only three days per week, but earning all they can during their time of work, so that the actual pressure of work by the individual workman may be regarded as maximal. The results are tabulated below. From the figures obtained we calculate as the average physiological cost (gross) per man 6.2 c.e.m. CO₂ per second, or 124 calories per hour. We hesitate to give even an approximate estimate of net cost, since we did not take resting or basal values, and the error incurred by assuming average values might be very large. Nevertheless, in order to allow of their inclusion in our general table, we give with due reservation the approximate net values per man and per square metre of body surface for this work, which obviously, in comparison with the values for dock labourers and cold storage labourers, are exceedingly low, of the same order as the values observed for tailors and printers.

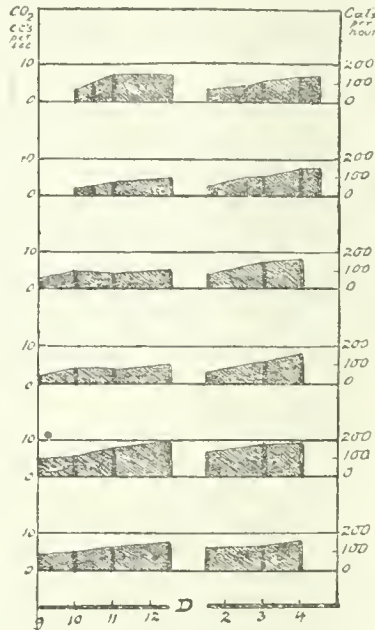

FIG. 3.—Shoemakers (gross cost of labour). (See also Table II.)

The CO₂ figures for the two subjects—C. S., aged 54, weight 70 kilos, and W. P., aged 49, weight 67 kilos—are recorded in Table II.

The relative energy output of colliers and of shoemakers comes out from our observations as three times greater for the former than for the latter—namely, 96 calories per hour per square metre of body surface in the case of

TABLE II. Showing Rate of Pulmonary Exhalation of CO₂ (c.e.m. per second) of two Male Operatives at the Boot and Shoe Factory of Messrs. C. and J. Clark, Ltd., Street, Somerset, during three days' work in the "Making-up Room" (Monday, Tuesday, and Wednesday, March 21st, 22nd, and 23rd, 1921. From 12.30 to 1.30 interval for dinner.

Date and Subject.	Time: A.M.		P.M.							
	9	10	10.30	11	12.30	1.30	2.30	3	4	4.30
March 21st.										
C. S.		3.4	5.6	7.0	7.0	3.3	4.1	5.8	6.8	7.0
W. P.		2.0	2.7	3.5	5.0	2.3	5.0	5.4	7.1	7.5
March 22nd.										
C. S.	...	3.0	5.0	—	4.0	5.4	4.1	—	7.5	8.0
W. P.	...	2.3	4.2	—	3.8	5.0	2.9	—	5.4	8.0
March 23rd.										
C. S.	...	5.0	5.6	—	7.5	8.2	6.6	—	8.7	8.7
W. P.	...	4.2	5.0	—	6.3	7.5	6.0	—	6.7	7.5

* The pulse frequencies of C. S. = 30 during the morning and 100 during the afternoon; those of W. P. = 72 throughout the day.

colliers, and 32 calories in the case of shoemakers. The relation of their energy output to that of other workers whom we have measured during the last two years is exhibited in the following table and graphs (Fig. 4). For purposes of strict comparison it is necessary to state the cost of work by individuals of different bulk in units per kilo of body weight, or preferably in units per square metre of body surface. But for practical purposes during investigation we find it useful to think in terms of (CO₂ calories) per second, which we translate at once into calories per hour by using the factor × 20. Our data have been presented under both of these forms in the graphs given below. In the left-hand graph the gross results are given in c.e.m. CO₂ per second (and calories per hour); the basal or subsistence values assumed at 1 c.e.m. per 20 kilos of body weight are shaded black; the remaining portions shaded grey indicate net cost per individual. In the right-hand graph these net values per individual are reduced to the common denomination of net values per square metre.

In connexion with this last table in which we have summarized the results of all the observations we have taken of various classes of "manual workers" during the last

REFERENCES.	BODYWEIGHT (kilohed)	BODY SURFACE (sq. m. each)	OCCUPATION.	NUMBER OF DAYS OR WEEKS OBSERVED.	CO ₂ cc's per sec gross - Do basal	CALORIES (GROSS) PER HOUR PER MAN.	CALORIES (NET) PER HOUR PER MAN.	CALORIES (gross) per hour per person.					CALORIES (net) per hour per square metre of body surface.
								(black - basal; shaded - net).					
								I	II	III	IV		
								5	10	15	20	REL. SEC. CO ₂ CC'S PER HOUR	
								100	200	300	400	CHLS PER HOUR	
1	86.0	2.0	DOCK LABOURERS Time work.	DAY, 6	14.3 - 9.3 = 10.0	286	100					286	100
			Piece work.	DAY, 3	21.8 - 4.3 = 17.5	436	175					436	175
2	67.0	1.8	COLD STORAGE LABOUR Piece work	DAY, 6	10.3 - 3.3 = 7.0	206	77			206			77
	74.0	1.8	Do (Smithfield). Piece work	DAY, 6	14.7 - 3.7 = 11.0	294	123				294		123
	71.0	1.8	Do Do Piece work	NIGHT, 6	14.4 - 3.7 = 10.7	288	119				288		119
3	62.3	1.7	TAILORS (men)	DAY, 17	5.85 - 3.1 = 2.75	117	32.4			117			32.4
	48.2	1.5	Do (women)	DAY, 7	5.15 - 2.4 = 2.75	103	36.6			103			36.6
4	73.0	1.9	PRINTERS (men)	DAY, 12	7.0 - 3.6 = 3.4	140	35.3			140			35.3
	48.0	1.4	Do (women)	DAY, 6	4.9 - 2.4 = 2.5	98	33.9			98			33.9
5	65.5	1.7	Do B.M.J	DAY, 24	5.3 - 3.3 = 2.0	106	24.0			106			24.0
6			TIMES PRINTING HOUSE										
	73.6	1.9	Composers	NIGHT, 8	8.1 - 3.7 = 4.4	162	47.0			162			47
	60.5	1.8	Castors	NIGHT, 12	10.0 - 3.0 = 7.0	200	77.0			200			77
	69.0	1.8	Printers	NIGHT, 12	10.9 - 3.5 = 7.4	218	82.0			218			82
	60.1	1.7	Readers.	NIGHT, 12	3.0 - 3.0 = 0	60	0			60			0
	65.0	1.74	founders.	NIGHT, 12	9.3 - 3.2 = 6.1	186	70.0			186			70
	66.2	1.77	Machinists.	NIGHT, 9	8.0 - 3.3 = 4.7	160	53.0			160			53
7	64.0	1.75	COLLIERS	DAY, 6	11.6 - 3.2 = 8.4	232	96.0			232			96
8	72.0	1.75	BELGIAN SOLDIERS (route march)	DAY, 4	15.1 - 3.6 = 12.5	322	143			322			143
			28 kilos load										
9	68.0	1.75	SHOE MAKERS	DAY, 6	6.2 - 3.1 = 2.8	124	32			124			32

FIG. 4.

two years, we desire to call particular attention to the grading we have been led to adopt in accordance with nature of work. Expressed in terms of cubic centimetres CO₂ exhaled per second (gross) and of the approximate caloric expenditure thereby signified, our grading is as follows:

	Cent. CO ₂ per Second.	Calories per Hour.
I. Sedentary work	Below 5	Below 100
II. Light	5 to 10	100 to 200
III. Medium	10 to 15	200 to 300
IV. Heavy	15 to 20	300 to 400
(Heaviest)	(Above 20)	(Above 400)

REFERENCES.

1. *Proceedings Royal Society, B.*, vol. 91, 1922, p. 165. 2. *Ibid.*, p. 227.
 3. *Proceedings Physiological Society*, December 20th, 1919. 4. *Ibid.*, January 31st, 1920. 5. *BRITISH MEDICAL JOURNAL*, March 17th, 1920.
 6. *Précisions Physiologica Société*, January 31st, 1920. 7. *Ibid.*, November 20th, 1920. 8. *Comptes Rendus de l'Académie Royale de Belgique*, December, 1920. 9. *BRITISH MEDICAL JOURNAL*.

INTERMITTENT ALBUMINURIA IN CHILDREN.

BY

F. MOOR, M.A., M.B., B.Ch.CANTAB.

By the term intermittent albuminuria is meant the condition in which a specimen of urine passed at one time of day is found to contain albumin, whereas a specimen from the same patient at another time of day is free from it. This condition is well known, and has been called by several names, of which cyclic, postural, orthostatic, lordotic, functional, and physiological are the commonest. Albuminuria is present only if the patient is up and about, and is absent if he remains in bed.

Etiology and Pathology.

Albuminuria is much more common in children than is generally supposed.

Samuel West¹ quotes the following figures for boys between 10 and 18 years of age:

Author.	Number Tested.	Percentage with Albuminuria.
Stirling	369	20.8
Ribbert	240	22.0
Dukes	Many years' experience	22 at least
Grainger Stewart	100	17.0

Stirling also shows that the incidence increases from the age of 12 to 15, and then decreases. Leslie Thorne Thorne² states that out of 1,890 boys between 9 and 16 years 9.1 per cent. had albuminuria; of these only fifteen (or 0.8 per cent.) had definitely hypertrophied hearts and increased arterial tension.

On examining the urine of 397 boys between 8 and 14 years of age at Vauxhall Street Elementary School I found albumin in 91 of the specimens (that is, 23 per cent.). The tests were carried out between 10 and 12 o'clock in the morning, the method employed being to add four drops of a concentrated solution of salicyl sulphonic acid to half an inch of urine in a test tube. The following table gives the age incidence in this series; no attempt was made to discover how many of these cases were intermittent.

Age	8	9	10	11	12	13	14
No. of cases	82	63	65	54	63	62	8
Percentage with albuminuria	12.5	17	22.5	21.5	31	30	50

With regard to sex incidence, it is generally assumed that albuminuria is commoner in boys, but there does not seem to be any evidence on the subject; out of 16 cases of intermittent albuminuria studied at the Evelina Hospital

for Children, only 4 were boys. In regard to age, the youngest case I have seen was a girl of 5½; the condition is said to be very rare after 20.

Most authors agree that children with intermittent albuminuria are debilitated, and some French physicians³ ascribe the condition to "phtuberculosis." Others lay stress upon the presence of lordosis in these cases, and Jelle⁴ goes so far as to say that he can produce albuminuria in normal children or prevent it in orthostatic children by mechanical means. In 6 cases in which I made special note of the spinal curvature, lordosis was present in 4 and absent in 2.

As intermittent albuminuria is not a fatal disease very few accounts of *post-mortem* findings have been published. Langstein⁵ describes a case of orthostatic albuminuria, which died of cerebral tumour, in which no abnormality was found in the kidneys either macroscopically or microscopically.

Several theories have been advanced to account for this condition, but each of them has the disadvantage of not explaining all the cases; the following are some of the best known:

1. That it is due to congestion of the kidneys, either by pressure on the renal veins or from some vasomotor abnormality.
2. That it is due to diminished coagulability of the blood, and is related to chilblains and urticaria, and may be cured by administration of calcium lactate for a few days.
3. That it is an early manifestation of tuberculosis.
4. That it is one of the neuroses of childhood.

Character of the Urine.

The amount of urine passed in two cases admitted as in-patients to the Evelina Hospital was found to be normal, more being secreted by day than by night.

The specific gravity varies between wide limits in individual cases. The albumin also varies in amount, but is seldom more than 0.05 per cent. by Esbach's method. It is generally absent from the morning specimen, and absent if the patient remains in bed; but in one of the cases treated as an in-patient a cloud of albumin was present in the morning specimen on one occasion, and the child had a temperature of 100° the same evening, for which no cause could be found; neither the morning albuminuria nor the pyrexia recurred. The other case admitted to hospital developed a very severe attack of gastro-enteritis, passing blood in the stools; one of the specimens obtained during this illness contained albumin although the patient was in bed. In patients who are up and about the amount of albumin increases to a maximum during the day, the time at which this is reached being constant in any individual case, so that one child would always have a trace at midday and a cloud in the evening, whilst another would always have a cloud at midday and none in the evening. In some cases a precipitate is formed in the cold by adding a few drops of acetic acid to the urine; some authors state that this is pathognomonic of intermittent albuminuria, but it is not present in all cases, and is sometimes found in other conditions such as cyclic vomiting and cardiac failure of diphtheria. The formation of this precipitate is slow, so in all probability it is often overlooked. Probably more than one substance is precipitated in this way, for in most specimens the cloud thus formed is increased by boiling, but in a few cases it disappeared on heating to re-form very slowly after cooling.

Casts are sometimes found in cases that appear to be simple intermittent albuminuria; hyaline types are commonest, although granular and epithelial are sometimes seen. Out of nineteen specimens of urine containing albumin from boys at Vauxhall Street School epithelial casts were found in one specimen, granular in four, and hyaline in one. Blood was not found in any of these cases, nor in any of those seen at Evelina Hospital.

Symptoms and Signs.

There can be no doubt that many cases occur without symptoms. There does, however, seem to be a syndrome associated with intermittent albuminuria which is quite characteristic but difficult to describe. Heubner says: "There is considerable atony and lassitude, which deprive these children of all joyfulness, alacrity, and pleasure of work." The patient generally cries when examined, and whimpers or "grizzles" a great deal at home; he is easily tired, and prefers sitting down to playing about. These children are subject to headaches and "bilious attacks," but are not constipated; they sleep well, and do not want to get up in the morning.

The children are asthenic and their pupils are unusually large; beyond this nothing was constantly found among the 16 cases at Evelina Hospital. The heart was enlarged in 2 cases only and the exercise tolerance was normal in

the 4 cases which were tested. The lungs presented abnormal signs in 6 cases, but none of these could be labelled phthisis; cough was not complained of. The blood pressure was found to be high in some cases—for instance, 140 mm.—and low in others, and the same may be said of the pulse pressure. Retinitis was not present in any case. Some of the children were pale but others had rosy cheeks. In most cases albuminuria was the only abnormality.

Renal Efficiency Tests.

The urea concentration test was carried out on 7 patients; this test, described by MacLean,⁵ consists of giving urea by mouth and estimating its concentration in the urine one and two hours later.

In every case the renal efficiency was normal, both when albumin was present and when it was absent. The following tables give the results in detail:

Patient.	Date.	Time.	Amount of Urine.	Albu- min.	Urea per cent- age.
V. W., aged 8. In bed. 10 grams urea given in 2 oz. water at 10 a.m.	1920. Oct. 15	10 a.m.	c cm.	0	1.1
		11 a.m.	113	0	2.5
		12 noon	78	0	3.1
Same patient up; bed at 5 p.m. Same dose of urea at 4 p.m.	Oct. 22	4 p.m.	—	+	1.0
		5 p.m.	31	++	2.8
		6 p.m.	40	+	3.6
B. L., aged 9. 10 grams urea given at 2 p.m. Patient up and about.	Oct. 14	Morning	—	0	2.9
		2 p.m.	—	±	1.75
		3 p.m.	51	±	3.0
		4 p.m.	40	+	4.5
D. R., aged 6. 7.5 grams urea at 10 a.m. Patient up and about.	Oct. 25	10 a.m.	—	±	0.3
		11 a.m.	173	0	0.8
		12 noon	53	0	2.25
E. L., aged 9. 10 grams urea at 10.15 a.m. Patient up and about.	Oct. 23	10.15 a.m.	—	+	1.2
		12.15 p.m.	—	+	2.35
P. L., aged 13. 10 grams urea at 11 a.m. Patient up and about.	Oct. 27	Morning	—	0	1.1
		11 a.m.	—	+	2.3
		12 noon	46	+	2.8
H. H., aged 11. 10 grams urea at 3.5 p.m. Patient up and about.	Oct. 15	3.5 p.m.	—	+	1.6
		4.5 p.m.	16	±	1.95
		5.5 p.m.	62	0	2.65
D. B., aged 15½. 5 grams urea at 9.45 a.m. Patient up and about.	Nov. 3	Morning	—	0	3.35
		9.45 a.m.	—	+	0.6
		10.45 a.m.	65	0	1.2
		11.45 a.m.	24	±	2.85
M. H., aged 6. 5 grams urea at 10 a.m. Patient up and about.	Oct. 13	10 a.m.	—	+	0.7
		11 a.m.	51	++	1.5
		12 noon	33	++	2.0

The following results in a case of chronic nephritis are given for comparison with the above. It will be seen that the kidneys are unable to concentrate urea to more than 1.1 per cent.

Patient.	Date.	Time.	Amount of Urine.	Albu- min.	Urea per cent- age.
D. R., aged 5½. In bed. 7.5 grams urea at 11.30 a.m. and 12.50 p.m.	1920. Oct. 14	11.30 a.m.	c.cm.	0.05 %	1.0
		12.30 p.m.	85	++	1.1
		1.30 p.m.	85	++	0.75
		12.50 p.m.	—	++	0.8
		1.50 p.m.	71	++	0.7
		2.50 p.m.	64	++	0.7

The blood urea test was not performed.

Diagnosis.

In children, as in adults, albuminuria is only one sign of nephritis. Intermittent albuminuria is scarcely likely to be mistaken for acute nephritis, for the amount of urine passed in the former is not diminished; it contains few, if any, casts and no blood, and there is no oedema; moreover, albumin is absent from the specimen passed on rising in the morning. The same features differentiate it from the hydraemic type of chronic nephritis (chronic parenchymatous nephritis). From the azotaemic type (chronic interstitial nephritis) it is distinguished by the fact that the amount of urine is increased and its specific gravity is low in the latter; also the cardio-vascular system may show changes and retinitis may be present. The urea concentration test gives normal values—that is, above 1.5 per cent. in the second hour—in intermittent albuminuria, whereas the figure is low in interstitial nephritis. It is said that during convalescence from acute nephritis albuminuria may be intermittent or orthostatic in type. Langdon Brown says that intermittent albuminuria may be differentiated from chronic nephritis by the fact that the administration of calcium lactate will check the former; this drug was tried in two cases, but had no effect. The albuminuria which occurs after violent exercise need not be discussed here.

Prognosis.

The prognosis seems to be largely a matter of personal opinion. Thus Taylor observes that bank clerks with orthostatic albuminuria are more often on sick leave than those without. Langstein sums up by saying, "There is a certain degree of inferiority in individuals affected with orthostatic albuminuria . . . as is illustrated by the fact that they are frequently a prey to tuberculosis." On the other hand, Clement Dukes,⁶ whose observations cover a long period, does not consider the outlook at all gloomy.

Conclusions.

1. Intermittent albuminuria is a common condition amongst children.
2. It is not a form of kidney disease.
3. It is called by so many different names, and there are so many theories about it that it is probably not a specific morbid entity, but a symptom of several diseases.

I am indebted to Dr. Boome for permission to publish the figures from Vauxhall Street School, and to the Headmaster, Mr. J. J. Thompson, for allowing me to test his boys and for the personal assistance he rendered in collecting the specimens.

REFERENCES.

- ¹ BRITISH MEDICAL JOURNAL, 1899, vol. i, p. 460. ² *Ibid.*, 1904, vol. i, p. 831. ³ *Thérapeutique Clinique Infantile*, Bossé, 1912. ⁴ *Diseases of Children*, Pfaunder and Schiössman. ⁵ *Lancet*, 1920, vol. i, p. 1305. ⁶ BRITISH MEDICAL JOURNAL, 1905, vol. ii, p. 848.

Memoranda:

MEDICAL, SURGICAL, OBSTETRICAL.

AN UNUSUALLY VIRULENT VARIETY OF MICROSPORON.

A boy, aged 13, had ringworm patches on the scalp, face and neck in July, 1917. Mycelium was found in scales, and the microsporon collar on hairs. A younger brother soon acquired the disease in multiple patches. Cultures were readily obtained of the same organism in both.

Macroscopic: On wort agar at summer room temperature it forms a round pinkish colony elevated towards the centre where there is a dimple from which numerous fine ridges radiate outwards like the gills of a mushroom. In about a week the surface shows numerous spiky projections which gradually develop white tufted summits like sheaves of corn.

On potato the culture is snow-white and furry without ridges or red colour. On neutral malt extract gelatine growth is as on potato with liquefaction in fourteen days. Though growth is coarser on wort agar, the same elements are found on all three.

Microscopic: Mycelium distinct, branching and septate, colourless; in a seventy hours' culture the larger hyphae (2 to 3 μ) often show pyriform swelling at the septa; in older cultures some hyphae show multiple septation into oidium-like elements (pseudoconidia). The snow-white surface of cultures consists of fertile aerial hyphae, many of them fasciculated into spiky projections, which branch near the tip to bear conidia. The conidiophores carry numerous colourless rounded conidia, 2 to 3 μ in diameter, unicellular, solitary, terminal, with a facet of articulation when detached. In hanging drop these readily

sprout. Chlamydo-spores are uncommon, usually arising by septation at the swellings on the hyphae. Septate spindles are infrequent, little divided or only bicellular, usually rough, 6 to 8 x 15 to 30 μ in size, and often constructed at the septa.

No pectinate hyphae or conspicuously whip-like branches were seen. In those respects, in the absence of red colour on potato and in earlier liquefaction of gelatine, it differs from a typical microsporion. I attach more importance to the pyriform swellings on the mycelium than to any or all of these; and it is on this character, together with its special pathogenicity, that I rely for referring the organism to microsporion. There have been observed in the equine microsporion the smooth culture (endoconidial form) and the chalky culture (oospora or streptothrix form), and in most microsporions the well known downy culture (acladium form) and the septate spindle (macrosporium form). My description is that of a furry culture in which the *branching* conidiophore cannot belong to any of these, but may be referred to a depauperate verticillium type—for example, *V. nanum*.

Under pathogenic conditions the ringworms produce only mycelium and oidium-like elements (pseudoconidia). The latter are formed by multiple septation of the already sparsely septated mycelium, and serve for dissemination of the disease and for infection of others. In cultures there are always, as well as these, one or several of the conidial forms mentioned above. These conidia, suitable for dissemination by wind or animals, carry on the saprophytic life. Sporadic cases, especially after injury or a scratch, are suggestive, and we assume that sporotrichosis usually arises in this way.

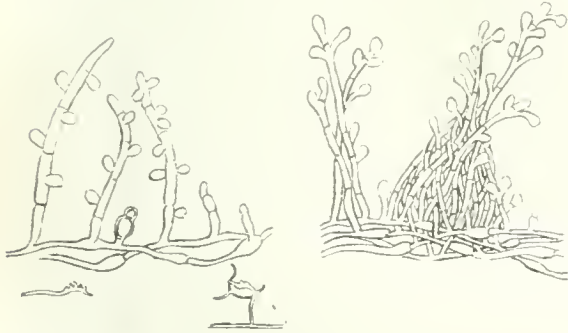

Fig. 1.—*M. audouini*.

Fig. 2.—New variety.

Fig. 1 shows *M. audouini*; Fig. 2 the new variety, with the projecting spike considerably shortened.

West Ealing.

ROBERT CRAIK.

RETENTION OF URINE DUE TO HAEMATOCOLPOS AND HAEMATOMETRA IN A CHILD.

I was asked to see a girl, aged 11, who was unable to pass urine. I found that the bladder was the size of an eight months pregnancy. She was removed to a private hospital near, and ether was administered. The vagina was found to be occluded by a thick leathery hymen. A catheter was passed and the hymen incised crucially; a large quantity of retained menstrual material evacuated under considerable tension. Recovery was uninterrupted. The mother was instructed as to the necessity for keeping the vagina patent.

This appears to be a rare cause of retention of urine in a child; naturally the absence of menstruation had given no cause for anxiety.

Malvern, Natal.

J. K. HAWORTH, M.S. Durh.

HERPES AND VARICELLA.

On March 26th a solicitor, aged 78, consulted me for what he considered an attack of gouty oozema. I found him with a profuse herpetic eruption along the left anterior crural nerve. There was at that date one decapitated pustule on the forehead, but that I discounted because he had been using silver nitrate as a caustic for two adjacent moles. During the next few days, however, he developed successive crops, on scalp, trunk, and limbs, of what was to all appearances a typical varicella eruption. We have in the neighbourhood a certain number of cases of varicella at the present time.

Hove.

DONALD HALL.

Reports of Societies.

HYPERTONIC SALINES IN THE TREATMENT OF CHOLERA.

At a meeting of the Section of Tropical Diseases and Parasitology of the Royal Society of Medicine on May 2nd Sir LEONARD ROGERS gave a further account of results, obtained in India, of the hypertonic saline treatment of cholera. What he had to say on this occasion was almost entirely statistical. After a reference to his earlier papers on the subject (BRITISH MEDICAL JOURNAL, September 24th, 1910, page 855) he said that he proposed to bring forward more particularly that evening the evidence relating to the last five years covered by his records (1915-19), during which the treatment had been modified by the addition of alkalis. His communication will best be summarized by reproducing the table which he gave at the close:

Period.	Method of Treatment.	Mortality.	Recovery.
1891-1905	Rectal and subcutaneous saline...	59.0%	41.0%
1895	Normal saline intravenously . . .	63.9%	39.1 .
1907	Rectal and subcutaneous saline . . .	59.5%	40.5 .
1905-09	Hypertonic salines intravenously	32.6%	67.4 .
1907-14	Hypertonic plus permanganate	25.9%	74.1 .
1915-19	Hypertonic plus permanganate and alkalis	20.8%	72.2%

The patients dealt with in this last period (1915-19) numbered 1,429, of whom 298 died. A point on which he laid particular stress was the reduction of mortality from uraemia as the result of the use of alkalis.

Out of 592 cases treated without alkalis in 1911-14, the total deaths were 152, and the uraemia deaths 66, a proportion of uraemia deaths to cases of 11.1 per cent.; of 584 cases treated with alkalis in 1915-17, the total number of deaths was 115, and of uraemia deaths 19, or 3.25 per cent., showing a reduction of mortality from uraemia of 70.7 per cent.

Sir Leonard Rogers pointed out how many factors had to be reckoned with in making comparisons and arriving at prognostic indications. The figures must not be taken haphazard without regard, for example, to seasonal variation. Cholera mortality in India was highest at the end and beginning of the year, and lowest in the rainy season; thus in cases treated before the hypertonic saline method was introduced the mortality might be somewhere about 72 per cent. in December and 48 per cent. in July. The same seasonal curve of mortality held good in the cases treated by the hypertonic saline method, although, of course, the mortality as a whole was reduced. The same fact emerged from a study of the mortality in relation to age. The effect of the new treatment as given in the last four years covered by his records was greatly to reduce the mortality in the middle age periods—for example between ten years and fifty years—though among the very young and the very old the mortality was still comparatively high. It was also necessary to take into account the stage of the disease at the time of the patient's admission. Sir Leonard Rogers showed tables correlating all these factors, as well as tables illustrating the corpuscular changes in the blood in cholera in relation to the effect of the injections, and, yet again, the records of rectal and axillary temperatures. Not until the rectal temperature was down to 98 F., or the axillary temperature to about 96 , did the mortality begin to be marked, but immediately below these levels it became very marked indeed. In another table he showed the number of saline injections per case and the mortality.

In 1912, when the cases showed the highest mortality in any year from 1912 to 1919 (51.7 per cent.; 71 per cent. of the patients had only one injection or no injection at all). Then the plan of increasing the number of injections was followed, and in the next year, when 42 per cent. had two injections, and 26 per cent. had three or four injections, the mortality fell to 24 per cent.; while in 1917, when the mortality was lowest in this group of years (14.6 per cent.), the cases which had three or four injections were 63.3 per cent. of the whole.

In reply to questions, Sir Leonard Rogers said that the hypertonic saline was very useful in cases of black-water fever. He also gave some experiences of cholera incidence. Cholera outbreaks followed a certain cycle. Should there be a high incidence in one year, there was unlikely to be a large outbreak the following year, even though the conditions favoured cholera, but it did not follow that when there were few cases the virulence among those attacked was less; indeed, when there were a large number of cases the mortality was rather lower.

The Ankylostomiasis Campaign in Egypt.

At the same meeting a paper by Dr. A. F. MacCALLAN on the ankylostomiasis campaign in Egypt was read in his absence. The campaign, which took place from 1913 to 1915, was carried out by means of travelling hospitals in towns and villages, and by surveys of the population and attention to sewage disposal and other measures. In the province in which the campaign was concentrated, the number of specimens examined was 4,445, representing about 1 per cent. of the male population; the investigation was restricted to males on account of the difficulty of examining women in Egypt. The number of patients treated, mainly by thymol, was nearly 2,000. All the ankylostomiasis hospitals had to close early in 1915 on account of the war, and the experiment came to a premature conclusion. The author laid down certain lines which should be followed in any resumption: (1) A knowledge must be obtained of the habitat of the larvae, which infected man by piercing his skin; (2) a workable system of village sanitation, entirely unknown at present, must be evolved; (3) a further investigation into the nature and mode of action of the ankylostomiasis toxins must be undertaken. He found no difficulty in interesting the people in the campaign.

Dr. J. B. CHRISTOPHERSON said that the three chief plagues of Egypt—ankylostomiasis, bilharziasis, and *Taenia nana*—were all agricultural diseases, not diseases of the towns, and therefore the appropriate plan of campaign was obviously the peripatetic hospital.

SURGERY OF THE RIGHT ILIAC FOSSA.

At a meeting of the South Essex Division of the British Medical Association on March 11th Mr. J. E. ADAMS, surgeon to St. Thomas's Hospital, gave a lecture on "Some points in the surgery of the right iliac fossa," of which the following is a summary:

Appendicitis.

If the case is seen within twenty-four hours of onset, operate at once; under such conditions the case mortality is a fraction of 1 per cent. If the diagnosis is not decisive, treatment should be (1) Fowler position, (2) starvation, and (3) no aperients. The Fowler position ensures any secondary peritoneal infection being confined to the pelvic peritoneum, which is undoubtedly more resistant and less liable to infection; (2) nothing should be given by the mouth, except perhaps cold water to assuage thirst, but even this can be controlled by saline rectal injections if a nurse is available; (3) no aperient should be given, because the desire is to inhibit peristalsis and thus ensure rest for the bowel. On the other hand, it is better not to give morphine, because the symptoms will then be masked. By waiting twenty-four hours any ordinary colic will have subsided under such treatment. If symptoms persist, then operate. The operation to be performed will depend on the condition found. If simple, the ordinary removal of the appendix. If an abscess is present, open and drain, and do the ordinary removal later. If there is an inflammatory mass, leave in a tube and, six weeks or so later, do the ordinary removal. The actual performance of the operation should occupy as little time as possible.

Ileo-caecal Tuberculosis.

This condition will occasionally be met with when operating for appendicitis. Its symptom-complex is as follows: A patient, aged between 20 and 40, whose general health is fairly good, will come complaining of a swelling in the right iliac fossa, which gives more or less continual discomfort, but little actual pain. On examination a tumour is found—firm, nodular, movable, cylindrical. The patient will probably also speak of constipation, and perhaps of nausea and vomiting. The treatment is to

remove the caecum and parts of the ileum and ascending colon—a modification of Friedrich's operation—doing an end-to-end or end-to-side anastomosis between the ileum and transverse colon. Results of this treatment are often very good, but a fatal termination may come from generalized dissemination of the infection.

Carcinoma of the Caecum.

The prognosis here is better than in all other parts of the intestinal tract with the exception of the rectum. The probable explanation is that the patient either discovers a tumour himself or diagnoses his case as appendicitis, and thus he seeks advice reasonably early. In suitable cases a widespread removal in the manner of Friedrich's operation is easily accomplished and glands are removed *en masse* with the bowel. In those cases where the growth is annular, obstruction may be the first manifestation of serious ill health, and the treatment of acute obstruction in this condition is very difficult. The best plan is to divide the ileum a short distance above the ileo-caecal valve and implant its upper end into the adjacent pelvic colon, and bring the distal end of the ileum out of the wound. In this way the obstruction may be overcome and the patient saved from absorption of septic material locked up between the ileo-caecal valve and the growth. This has frequently been the cause of death in cases treated by ileostomy alone. If the lower end of the ileum is fixed in the wound irrigation can be carried out by means of a catheter passed through the valve. If a good recovery is made from obstruction, resection of the whole growth and bowel may be carried out later.

Coccyptosis.

The mobile caecum does not necessarily give rise to any symptoms. If it does do so these may be referred to the upper abdomen, and frequently the patient may complain of "indigestion." Gastric and duodenal ulcer, gall stones, Dietl's crises, and appendicitis may all be simulated by an abnormally mobile caecum, and some authorities look upon prolapse of the caecum and ascending colon as the initial lesion in these diseases. Treatment may be effected by a suitable belt or by operative fixation (colopexy). If operation is done, a well fitting belt or corset is an essential part of the after-treatment. In most of the cases a psychological element is present, and this must not be lost sight of by the surgeon who would treat these patients successfully.

WITH regard to the apparatus for mechanical distribution of reagents in the final Wassermann test, mentioned in the JOURNAL last week as having been shown at the pathological meeting of the Liverpool Medical Institution on April 14th, Professor E. GLYNN stated that one source of error in the Wassermann reaction was inaccurate measurement of the reagents used in the final test. In No. 4 technique of the Medical Research Council fifty Wassermann tests necessitated the distribution of 600 $\frac{1}{2}$ c.cm. or $\frac{1}{4}$ c.cm. doses of various fluids with a pipette or burette, if the drop method was not used. This distribution took a considerable time, and there was often considerable error from fatigue or boredom. He had devised a semi-automatic machine which simultaneously filled twelve Wassermann tubes with $\frac{1}{2}$ c.cm. doses of any reagent, a rack containing thirty-six tubes being filled in a few seconds. It was impossible to distribute more or less than $\frac{1}{2}$ c.cm. at a time. The error of the machine was tested with distilled water at 15° C. The maximum error was apparently ± 3 per cent., and the average ± 1 per cent.; this was at least half the error obtained with pipettes or burettes when only twelve doses not 600 were distributed, and more than the usual precautions were taken in measuring. One reason for the accuracy of the apparatus was the fact that often after the expulsion of each dose no drop remained behind on the nozzles. He had also devised a syringe for distributing automatically three $\frac{1}{2}$ c.cm. doses of the diluted serum of the patient. This syringe was accurate, and also left no drops. After using a given diluted serum the syringe was washed out twice with saline before taking the next serum. Saliicyl-sulphonic acid, which would detect one part of albumin in 10,000, produced no turbidity with a third washing.

THE first departments of the Jerusalem University to be opened will deal with microbiology and medical research, and the Jerusalem University Library Committee in this country asks for gifts of books, sets of scientific journals and transactions, and official reports bearing on these subjects, and also for good textbooks of established repute. Communications may be addressed to Mr. D. B. Stanhill, B.Sc., 75, Great Russell Street, London, W.C.1.

Rebuelus.

BAYLISS'S "GENERAL PHYSIOLOGY."

The success of Professor W. M. BAYLISS'S *Principles of General Physiology*¹ is proved by the appearance of a third edition two years after the second and four years after the first of this truly philosophic and encyclopaedic work, and this in spite of the obstacle that it is of necessity rather highly priced, at any rate as judged by pre-war standards, for the student. It is so pleasantly and fairly written, so complete without being tedious, and the summaries at the end of the sections are so clear that it recalls the advice given more than thirty years ago by a well-known hospital physician to a student's inquiry for the best book on medicine to read: "*Foster's Physiology*." The ground covered by this fascinating and beautifully illustrated book, which, besides giving the most recent advances, includes the historical foundations of the science, is most extensive, and thus shows the relation of physiology to other branches of natural learning. The whole of the text has been revised, and observations made since the last edition have been added.

The importance of a thorough grasp of general physiological principles as a basis on which medical men can best assimilate new developments in practical medicine must be borne in mind in deciding how much instruction the medical student should receive. On account of the multitudinous demands made by the medical curriculum, and the comparatively short time available, there is, not unnaturally, much serious discussion on the problem how the teaching of the pre-clinical sciences can be best arranged or even curtailed so as to be of the greatest value to the future practitioner; but, as Professor Bayliss points out, what at the moment is regarded as pure abstract or academic science may next week be obviously of the greatest importance in direct application to clinical work. On the other hand, general principles may be illustrated by, and brought into relation with, details that will subsequently become most familiar in daily practice.

In the new section on the capillary circulation full attention is paid to the researches of Dr. H. H. Dale and his colleagues on histamine, but a discussion as to the mechanism by which this substance causes a fall of blood pressure is left open; Professor Bayliss finds it difficult to believe that the peripheral resistance can be appreciably diminished by capillary dilatation alone, and still regards the chief peripheral resistance as provided by the arterioles. In the short account of wound shock and traumatic toxæmia the results of the Medical Research Council's committee on shock are epitomized, and stress is laid on the importance of maintaining the normal volume of the blood, for dilution of the blood up to very wide limits has comparatively little significance as long as the volume remains normal.

In the interesting description of the hormones it is specially mentioned that the word was proposed by Mr. W. B. Hardy, which, though not conveying the desired implication of a messenger, has been generally adopted, and that in 1891 Brown-Séquard and d'Arsonval published a brief note on the conception of chemical messengers. The distinction drawn by Sir E. Sharpey Schafer between exciting substances (hormones) and depressing bodies (chalones) is regarded as unnecessary, as is also the use of the name "autocoids" to include them both. The account of anaphylaxis has been brought up to date; after showing that the phenomena are not satisfactorily explained by the hypothesis of specific chemo-receptors, preference is given to the view that a colloidal precipitation at the surface of the sensitive cells destroys more or less the semi-permeability of the cells.

In conclusion, it may safely be said that every medical man will be the better for acquaintance with this guide to sound physiological knowledge.

THE PSYCHOLOGY OF PHANTASY.

DR. CONSTANCE E. LONG is one of the leading exponents in this country of the Jung school, and has been largely responsible for making the work of the Zurich psychologist accessible to the English reader. She has now collected a

number of her personal contributions, and has published them in a book with the title of *The Psychology of Phantasy*. The book will be read with interest as indicating the psychological outlook of the particular school of which she is an adherent. Eleven papers are included in this volume and they cover a variety of topics of psychological interest. The first four are concerned with the mental development of children, with special reference to mental conflicts, the unconscious mind, fear, authority, and discipline. In her preface Dr. Long states that a candid friend, who happened to be an academic psychologist, told her that her book had nothing to do with psychology. This may or may not be so; but, whatever her book has to do with, its author has certainly a sympathetic understanding and insight into the mind of a child, and has much to say of value to those who are in a measure responsible for its satisfactory development.

In subsequent chapters Dr. Long discusses such matters as the censor and unconscious symbolism in dreams, sex as a basis of character, unconscious factors in sex, education, and the significance of phantasy in the production of the psychoneuroses. She also devotes a chapter to the discussion of Jung's *Psychology of the Unconscious*—a book which Miss Long rightly describes as "formless," and one which many of its readers will be glad to have explained. A careful study of these papers will make the reader conversant with the difference in outlook between the opposing schools of Jung and Freud, because Dr. Long writes not only attractively but clearly. She herself thinks that many ideas are implicit in the *Traumutung*, which have been explicitly developed by the school to which she belongs, though the Freudians strenuously deny this. It may be so; but her book would seem to show that the differences between the two schools are fundamental and irreconcilable. It is one thing to explain the Oedipus complex psychologically in terms of regression to a child-like longing for love and protection, and quite another to do so completely and physically. It is difficult to harmonize the view of an unconscious "as the source of intuitive knowledge and origin of religions . . . the germinal place of emotional and mental forces . . . a chaos of infinite resources . . . the kingdom of heaven within us," with that of an unconscious "incompatible with the civilized conscious personality . . . sexual in character . . . of a crude and infantile type." Nor is it easy to find obvious points of contact between a psychology which seeks to interpret a dream in terms of some high task in life unfulfilled and one which does so in terms of some base and heavily disguised desire, furtively seeking expression under cover of darkness. Dr. Long suggests that the difference between these divergent views is, in a measure, a matter of emphasis. It is doubtful whether she really thinks this, and still more doubtful whether her readers will do so. It is not for the reviewer to determine which is right, but the difference between these two schools of thought is certainly fundamental.

RADIOGRAPHY.

UNDER the title of *Radiographic Technique* Mr. THOMAS BAKER publishes a manual which deals with a somewhat neglected branch of radiology—namely, the photographic side of the art. The author states in the opening sentence of his preface that the book has been written with the object of placing before the reader the various details of photographic technique of which a knowledge is so necessary in radiographic practice; and he goes on to point out that the photographic knowledge of many operators is lamentably deficient. The book, however, is not by any means limited to a mere description of photographic methods; amongst other things, for instance, there is a chapter on intensifying screens, in which their use, the physical properties underlying their use, the way in which they should be used, and the modifications in development due to their use, are all discussed. There is also a valuable chapter on the fluorescent screen, screen stands, and protection. The chapter dealing with the photographic print is full of hints as to the best manner of reproduction from the X-ray negative—a much neglected

¹ *C. Lectures on the Psychology of Phantasy*, By Dr. Constance E. Long. London: Baillière, Tindall, and Cox, 1920. (Demy 8vo, pp. vii + 216. 10s. net.)

² *Radiographic Technique*, By T. Thomas Baker, A.M.B.E., London: Lippincott and Co., Ltd., 1921. (Demy 8vo, pp. 203; 42 figures. 15s. net.)

¹ *Principles of General Physiology*. By W. M. Bayliss. London: Longmans, Green and Co., 1920. (Roy. 8vo, pp. 826; 260 figures. 28s. net.)

branch of *x* ray work and yet an extremely important one to experts. In issuing reports on cases to medical men it is so frequently forgotten that brilliant and well set out prints are often the criterion by which radiographic work is judged; if poor prints are sent, the doctor is apt to lay less stress on the value of the accompanying opinion. The book, which contains also a chapter upon the industrial applications of *x* rays and an appendix containing many formulae, is well got up, excellently illustrated, and full of sound and interesting material. It should appeal not only to experts, but to all workers in either a hospital or private *x*-ray department.

The first edition of the *Roentgen Diagnosis of Diseases of the Alimentary Canal*⁴ appeared under the names of CARMAN and MILLER, the second is published under that of Carman only. Everything has been thoroughly brought up to date, many of the chapters have been entirely revised, and two have been added on the hour-glass stomach and on pneumoperitoneal diagnosis of abdominal lesions. These changes have increased the size of the volume by 98 pages and 122 illustrations. The vast amount of material at the disposal of the author in the Mayo Clinic is obvious throughout, and much of the value of this book is due to the fact that the *x*-ray part of the work is, so to speak, controlled by the system of the clinic, and the *x*-ray findings can be compared with all other findings, operative and other. The new chapter on pneumoperitoneal diagnosis consists entirely of references to, and quotations from, the various papers which led up to and finally established this method. In summing up its value the author states that if the patients for examination are carefully chosen pneumoperitonemum may be expected to prove a valuable aid to diagnosis, but should be resorted to only after all other methods of examination have failed. A warning is also given that the radiologist should be chary of reading something into the plates that he does not clearly see. The other new chapter, that on the hour-glass stomach, is full of valuable material. Four varieties are recognized and discussed: the congenital—very rare; the organic, the spasmodic or functional, and the false hour-glass. The methods of differential diagnosis and the uses of belladonna and atropine in doubtful cases are set forth. Other good features of the volume are the very excellent illustrations, the notes on typical cases, and the full references to literature following each chapter. In its new form this book probably remains the best hitherto published on the subject.

The volume entitled *Radiologie et Radiumthérapie*,⁵ by BÉCLÈRE, COTTENOT and Mme. LABORDE, is the thirty-second of a series of books published under the general direction of Drs. Sergent, Ribadeau-Dumas, and Babonneix. After an introduction by Dr. Béclère, a physician who is one of the most eminent radiologists in Paris, Dr. Paul Cottenot deals in succession with *x* rays and the apparatus for producing them, with dangers to the operator and method of protection, and with the general technique of diagnosis by *x* rays. Their application for this purpose to the skeleton, the thorax, the lungs, the heart, the oesophagus, the stomach, the intestines, and the kidneys is discussed seriatim. The second part, on radium therapy, is by Dr. Laborde; it also follows the usual conventional lines with an introduction and chapters on general principles, apparatus, and general technique. Malignant tumours, pathological conditions of the skin, the uses of radium in gynaecology, all come under review, and the book concludes with chapters on diseases of the blood, gout, rheumatism, and so on. A considerable number of illustrations are included, but, as in many French books, they do not reach a very high standard of excellence; many of them, reproduced on the ordinary paper of the letterpress, and interspersed with the text, do not adequately demonstrate the conditions they are supposed to show, whilst some are singularly poor. Authors should remember that it is better not to introduce illustrations at all than to use those which do

not show definitely the points under discussion. Apart from this fault the volume is well got up, and is a good textbook.

DERMATOLOGY.

DR. HIGHMAN has produced a very sound and not over-elaborated textbook of dermatology.⁶ It is designed especially for students, and consequently much greater space has, very properly, been allotted to the commoner diseases than to those which may best be designated dermatological curiosities. Although most of the rarer conditions of the skin have been included, the sections dealing with them are printed in smaller type than the main body of the book. The descriptions of the various diseases are good, and often written with an American raciness which is quite attractive and likely to assist the student in fixing the important points in his memory. Due attention is given to questions of diagnosis, and treatment is adequately dealt with; the mind is not confused with a mass of prescriptions without guidance as to their proper employment, but a few well-tried formulae are given with the proper indications for their use.

Dr. Highman adopts a curious classification which we do not remember to have seen previously, into autochthonous and non autochthonous diseases. Apparently autochthonous diseases are those strictly limited to the skin only, while the others have some connexion with the internal organs of the body. This classification is forced and does not seem likely to be followed by other dermatologists. It leads him to write four sections on (1) Pure dermatoses, (2) Parasitic diseases and infections, (3) Neoplasms and naevi, (4) Diseases of the organs of the skin and of the mucous membrane, and a fifth section devoted to syphilis alone. But, after all, it does not much matter from the point of view of the student what classification is adopted so long as he can find the information he wants without difficulty, and this with the help of the table of contents and the index he can do. The photographs with which the volume is embellished are for the most part excellent and well chosen to bring out the characteristics of the conditions illustrated. But Fig. 17, of pemphigus vulgaris, is poor. The explanatory notes pointing out the salient characteristics depicted are distinctly useful. Altogether the book is a very practical introduction to the subject.

NOTES ON BOOKS.

THE report of the Library Committee of the College of Physicians of Philadelphia for 1920 is remarkable chiefly for the list of rare medical books which were added during the year. No less than 34 monographs, many of them extremely rare and valuable, 121 early medical works of special interest, and 6 manuscripts, are included in the list. The total number of volumes in the library, including some 16,000 unbound reports and transactions, is now more than 125,500. This does not include unbound theses, dissertations, and pamphlets to the number of 120,400.

The *Purple Sapphire*⁷ is the title of a clever little book of short stories. It professes to be a selection from a number of manuscripts deposited for safe keeping with CHRISTOPHER BLAYRE, Registrar of the University of Cosmopolis, during the early years of the twentieth century, and given to the public in 1952. In order to enjoy them to the full the reader should first study the editorial "antescrpt," the contents table or "list of selected papers," and the three quotations from scientific writers printed in front of the first chapter. Internal evidence proves the author to be someone with first-hand knowledge of the world of science and a gift for dramatic narrative. Since Poe's time various writers have tried their hand at the "bogey" short story in English—notably Kipling, Marion Crawford, Conan Doyle, and Montague James. The present collection of tales may contain nothing quite so good in its way as "The Mark of the Beast" or "Lot No. 249," but most of them are very well done. Our admiration is compelled by the ingenious manner in which the circumstances are handled

⁴ *The Roentgen Diagnosis of Diseases of the Alimentary Canal*. By Russell D. Carman, M.D. Second edition, revised. Philadelphia and London: W. B. Saunders Company. 1920. (Roy. 8vo, pp. 676; 626 figures, 125, net.)
⁵ *Radiologie et Radiumthérapie*. By Drs. Béclère, Cottenot, and Mme. Laborde. Paris: A. Maloine et Fils. 1921. (Demij 8vo, pp. 527; 170 figures.)

⁶ *Dermatology. The Essentials of Cutaneous Medicine*. By W. J. Highman, M.D. New York: The Macmillan Company. 1921. (Roy. 8vo, pp. 498; 93 figures, 35s. net.)
⁷ *The Purple Sapphire and other Posthumous Papers*. Selected from the Unofficial Records of the University of Cosmopolis by Christopher Blayre. London: P. Allan and Co. 1921. (Cr. 8vo, pp. 210. 7s. 6d. net.)

has to give an air of probability to the wildest flight of fancy. In order, we suppose, to heighten this effect, the ninth and last narrative, which, according to the table of contents, was "deposited by the Professor of Biology," is missing: "The publishers regret that they are unable to print this MS."

The latest addition to the "Notable Trial Series" is the *Trial of Thurtell and Hunt* for the murder, on October 24th, 1823 of William Weare in a gig near Gill's Hill Cottage, close to Elstree; it is edited, with an interesting explanatory introduction, by Mr. ERIC R. WATSON,⁸ who previously brought out the volume on Eugene Aram in this series. This trial, though devoid of any thrilling mystery or psychological puzzle, forms an important landmark in legal history for several reasons: it was almost the last famous trial under the old Tudor procedure, rightly described by the presiding judge as inquisitorial; it was the first "trial by newspaper," and the first in which there was a serious collision between the bench and the press as to the duties of the latter in relation to the investigation of crime, for there was a virulent campaign, especially by the *Times*, against the prisoners; it has hardly a parallel as a murder undertaken solely for the sake of money by persons unconnected by family ties. Before the trial the supposed incidents of the murder, illustrated by the horse and the gig in which the deed was done, were given at the Surrey Theatre in a play called *The Gamblers*. The sketches of the three villains, Thomas Thurtell and his two associates, Hunt and Probert, are reproduced from drawings by Mulready never previously published. Of the two latter the editor remarks that the lineaments are those of human beings, but that there all resemblance to human nature ceases, and that in comparison Burke and Hare appear to be angelic beings. Probert turned King's evidence, but was executed a year later for stealing a horse; Hunt, a craven coward, was transported to Botany Bay. John Thurtell was made of sterner stuff and defended himself vigorously, but in vain, at the trial before Sir Alan Park, who is described by the editor as "deeply but narrowly religious, hot tempered, irritable and rather old-womanish, with much self-complacency and a full share of that judicial simplicity which affects not to know the slang of the day." At the execution "when his neck broke it went off like a pistol," to quote from George Borrow, and his body was publicly dissected by Abernethy at St. Bartholomew's Hospital, where thousands visited his ghastly lying-in-state. The evidence is given in full, and there are five appendices in this well-edited record, which is dedicated to Sir Harry Bodkin Poland.

Trial of Thurtell and Hunt. Edited by Eric R. Watson, LL.B., Barrister at Law. Notable Trial Series. Edinburgh and London: William Hodge and Co., Ltd. 1921. (Demy 8vo, pp. 225; illustrated, 10s. 6d. net.)

THE WELSH NATIONAL SCHOOL OF MEDICINE.

The medical school of the University of Wales attached to the University College of South Wales and Monmouthshire at Cardiff is about to be completed. The school has for the past thirty years provided for the requirements of the first three years of the medical curriculum, with results which compare well with those obtained in other universities.

The University Council, at its meeting at Aberystwyth recently, acceded to the application of the College Council for a grant of £13,000 per annum for the completion of the Welsh National School of Medicine. The Council of the college is therefore now in a position to carry out its scheme for the constitution of the National School of Medicine as an integral part of the University College in the Welsh metropolises.

Chairs in pathology and bacteriology, preventive medicine, and tuberculosis have already been established, but the departments for these branches of medical education are not yet completed. It is now intended to establish a complete medical school. Full-time professors in medicine, surgery, and gynaecology and obstetrics, with lecturers in the remaining departments, are shortly to be appointed. Advertisements for professors of medicine and surgery appear in our columns this week. Clinical instruction will be given at the chief general hospital the King Edward VII Hospital, Cardiff - which may possibly in the future be associated for this purpose with other local institutions, such as the workhouse infirmary and the Seamen's Hospital.

The hospital serves a densely populated industrial area which, within a radius of twenty miles, includes over 1,000,000 people, two-thirds of the total population of Wales. There is an abundance of clinical material at the hospital, which from its outpatient department could always keep fully occupied an institution of 1,000 beds. Sir William Diamond, well known in local shipping and industrial circles, is chairman of the board of management, and under his guidance the institution is likely to become one of the best of its kind in Great Britain. The original scheme of 1912 included a considerable extension of the present accommodation of 300 beds, the additional beds to be in charge of the professors of the separate units, but this plan is for the present unattainable, for financial reasons which affect the Principality in common with other parts of the country.

A charter of incorporation has been drawn up embracing the university and the hospital, and a joint conference of representatives is about to meet to discuss further the matters of mutual interest and to determine the probable date of completion. The new scheme will involve a division of the existing beds between the present members of the honorary staff and the unit professors.

A small convalescent home attached to the hospital is situated at Lavenock on the coast, a few miles distant; there is considerable room for extension, and the hospital authorities, it is thought, might consider the desirability of establishing a large convalescent branch of the institution so as to release beds speedily at the central hospital. The present area occupied by the hospital does not offer any room for extension, although it has been suggested that the adjoining road and street may meet this difficulty. The idea of extension at the convalescent home is favoured as far less costly than extension of the hospital on a site close to the centre of the city.

There is a body of opinion, including members of the honorary staff of the hospital, which favours a postponement of the operation of the present scheme of completion, owing to the contemplated measures of reconstruction and rearrangement at the hospital, as advised by Dr. Donald J. Mackintosh, of Glasgow, and owing to the lack of adequate laboratory and other facilities for the reception of students. It is probable that these wants will be promptly remedied, and that an early start will be made in what should ultimately become one of the best complete schools of medicine in the country.

The project was considered in 1916 by the Royal Commission on Welsh University Education, presided over by Lord Haldane, and its recommendation of the unit system was accepted. The College authorities wish, without further delay, to take full advantage of the present vigorous impulse in medical education which the school enjoys in common with those attached to other universities.

The school of preliminary and intermediate studies has at present 250 students, and most of those about to finish the third year of study have expressed a desire to complete their education locally. For this reason the university is most anxious to complete the medical school by the commencement of the forthcoming session in October next.

The sixth French Congress of Medical Jurisprudence will be held on May 23rd and 24th at Brussels, and on the 25th and 26th at Liège.

THE International Labour Office announces that it has received a request from the League of Nations to appoint a delegate to the Temporary Health Committee of the International Health Organization of the League. The need for such a committee arises from the fact that certain diplomatic measures have to be concluded before the permanent Health Organization, as decided by the League Assembly, can be set up, and it is essential meanwhile that there should be no delay in carrying out the duties imposed on the League in connexion with international health problems. The Temporary Health Committee, which will meet in Paris early this month, is to consist of twelve members: A delegate from each of the States permanently represented on the Council of the League of Nations - France, Great Britain, Italy, and Japan; a delegate from the League of Red Cross Societies; a delegate of the International Labour Office; the President of the "Bureau International d'Hygiène publique"; and five delegates appointed by the Committee of that body. The committee will cease to exist when the permanent organization is set up.

British Medical Journal.

SATURDAY, MAY 7TH, 1921.

THE TUBERCULOSIS REGULATIONS, 1921.

WE referred on April 9th to the termination of sanatorium benefit under the National Insurance Act, 1911, and to the obligation now resting upon county and county borough councils to provide institutional treatment for insured persons. Consequent upon this alteration, and also owing to the formation of the Ministry of Health, it has been found necessary to amend the Tuberculosis Regulations made by the Local Government Board on December 19th, 1912. The new amending Public Health (Tuberculosis) Regulations, which are dated April 21st, 1921, refer to important particulars in the register of tuberculosis notifications which is required to be kept by every medical officer of health under Article XI of the 1912 Regulations. This register is now to be open to the inspection of the medical officer of a tuberculosis dispensary which serves any area within the district to which the register refers, in addition to those persons who are already authorized to inspect it.

In January last the Minister of Health asked for a return from medical officers of health of all cases of tuberculosis resident in their districts on January 1st, 1921, as shown by the registers. Many medical officers of health took great pains to revise the register in order that the return should be accurate. There were others who had to admit that the return sent in could not be relied upon as a trustworthy index of the incidence of tuberculosis within their districts. The new Regulations require that the register shall be revised by the medical officer of health at least once every three months by removing the names of those persons who have died or who have removed permanently from the district. Particulars of those cases which have permanently removed must be sent to the medical officer of health of the district to which the person has removed. These new Regulations are excellent, and there will be no great difficulty in carrying them out in large towns and where the medical officer of health is the tuberculosis officer. For country districts, however—namely, small urban and rural districts—the Regulations do not go far enough. The medical officer of health, in addition to keeping a register of notifications received by him, is required either personally or by deputy to make inquiries with regard to cases notified and to take steps to remove conditions favourable to infection. That is to say, he must see to the removal of insanitary conditions. These conditions having been removed, however, the medical officer of health can render little further service. Far otherwise is it with the tuberculosis officer, who should keep in constant touch with the patient, and who is the first—or should be the first—to know of any change of address.

The Minister of Health might therefore very well have made a regulation requiring a county medical officer of health, a tuberculosis officer, a school medical officer, a sanitary inspector, or a health visitor, to notify to the district medical officer of health the change

of address of any tuberculous person which comes to their notice, and also requiring the medical officer of health on receiving such notification from any other official to forward a copy to the tuberculosis officer. This brings us to the need of co-operation between the medical officer of health and the tuberculosis officer, which was so strongly urged by the Local Government Board as long ago as 1912. It is to be feared that this co-operation in many counties is lacking, and the best results will not be attained until it is brought about. The manner in which it could be achieved was pointed out by the Local Government Board in a circular dated December 20th, 1912, to which attention has again been drawn by the Ministry of Health; it was suggested that the tuberculosis officer should, for the purpose of the Tuberculosis Regulations, act as an officer of the sanitary authority under the direction of the medical officer of health. We should like to see a return showing those counties in which this suggestion has been adopted and to be informed as to its success.

We believe that the majority of the tuberculosis officers throughout the country are carrying out their duties with advantage to the community; but in some counties the administration leaves much to be desired, and the reason for this is that there is far too much overlapping in the work of the various officials. This overlapping can be remedied if the officials of the Ministry of Health will only apply themselves to the task.

NAPOLEON.

AT 5.49 p.m. on Saturday, May 5th, 1821, the Great Napoleon died at Longwood, St. Helena, an exile and a prisoner: "The last single captive to millions in war." A hundred years have elapsed since that event took place, and this week the whole of Western Civilization is uniting to do homage to that great name. For many years now the memory of Napoleon has been occupying a continually increasing share of the thoughts of mankind, and in latter times the mists of prejudice have in large measure been cleared away, leaving the historic figure of Napoleon in truer perspective and enabling us to make a juster estimate of his mission in the world. This week the press is being deluged with appreciations, analyses, and critical reviews, and perhaps from them all will emerge some definite conception of the real Napoleon. What is the secret of the hold this man has upon the human imagination? Dare we attempt a solution of the problem?

The eighteenth century was occupied mainly in freeing itself from the last strangle-hold of the feudal system of civilization, and the weapon used was the spirit of free inquiry. Under repeated assaults this system, which had long outlived its usefulness, which for centuries had held the human race in bondage, which had established for its own security the idea of hereditary power, and which demanded a blind belief in certain principles necessary for its existence, began to sway and totter. Voltaire convinced mankind that it should suffer no penalty for thinking as it pleased, and Rousseau insisted that all men were born free and equal. The wide acceptance of these principles sounded the death-knell of feudalism, and in 1789 it fell with a resounding crash. The old order was swept away, the old slavish adherence to so-called "authority" was gone; and men were told that all were free and equal, were to serve no master and to worship no God. The pendulum had swung to the farthest point from servitude, and it was

about to move again in obedience to the immutable law. The time had arrived, and the man, in the person of Napoleon.

He came without a name, without a country, educated on the charity of France, devoid of rank and fortune, but possessing the most amazing efficiency of brain that the world has ever seen. Cold, collected, and unerring in thought, "steady as bronze, quick as lightning." Not cruel, but merciless to anything that stood in the way of the attainment of his wishes, the very embodiment of the new world, which cared not for right, which demanded only efficiency. And so France followed Napoleon, each man carrying in his knapsack a marshal's baton, and cheerfully giving him servitude in return for the career open to ability. Rank and birth did not count. What wonder Napoleon became master of the world and that among his followers there could be found, in the person of a common postillion of a country inn, the most fearless cavalry officer the world had ever seen, and one judged fit to be a king. Everything was possible.

Napoleon possessed in a superlative degree all the qualities coveted by the ordinary man of the world, and in that sense is truly a representative man. He was also thoroughly representative of the modern system, as opposed to the ancient on which Europe had existed for many centuries. He was the head of a galloping, breathless age intoxicated with a newly found freedom, where the meanest born might become powerful did he only possess brain efficiency. To science he was ever ready to give a helping hand, firmly convinced as he was that the progress of science meant the advancement of the State. Chemistry in particular he fostered, because he realized that it was the foundation of industries useful to the community. His mathematical mind could not accept a science so inexact as medicine, and he was prone to belittle the efforts of the physician, but he would have understood and applied the recent achievements of preventive medicine, and he has left on record a noble appreciation of the work of the great surgeon Larrey, designated by him the most honest man he had ever met.

Much has been said about Napoleon's attitude towards democracy, and attempts have been made to read into his life a tendency in that direction. But how could it be so? Napoleon was individualistic to the core, and although the community might benefit in the long run, the prime motive was always personal advancement. His success was phenomenal and failure seemed a remote possibility. He was a dazzling military genius, a mighty law-giver, a far-seeing and consummate statesman, endowed with greater powers of intellect and endurance than had ever been given to man; then came the crash of Waterloo and the agony of St. Helena. Did any man ever climb to such giddy heights and then fall so far? What is left of the Napoleonic system? Military despotism, always questionable, has received its death-blow after our experiences of the late war. Napoleon's European system has long since been rejected. Only the mighty "Code Napoleon" founded on the principles of equity remains. But the personality of Napoleon will hold its sway over the world for ever. As Emerson has said, "We are all little Napoleons," and whenever we think in terms of brain efficiency, unconsciously we have in mind Napoleon, the greatest example of "brainlessness," who came from nothing and who gained everything by sheer force of intellect. That is why, as Alison has said, "Napoleon will live when Paris is in ruins; his deeds will survive the Dome of the Invalides."

THE ANNUAL MEETING AT NEWCASTLE.

WE publish in the SUPPLEMENT this week revised information about the arrangements made by the local Committee for the accommodation of members in hotels and hostels in Newcastle and its neighbourhood during the forthcoming Annual Meeting of the British Medical Association. We are asked to call the attention of our readers to the importance of making early arrangements, especially as regards hotels. If this is done, the Hotel and Lodgings Committee have every confidence that ample accommodation will be found for all their visitors. The Honorary Secretary of this Committee is Dr. E. F. Murray, 52, Jesmond Road, Newcastle-upon-Tyne.

THE INSTITUTE OF PHYSICS.

THE Institute of Physics was inaugurated at a largely attended meeting in the hall of the Institution of Civil Engineers on April 27th. The need has long been felt for a corporate body, analogous to the Institute of Chemistry, which should strengthen the position of workers engaged in physics, and form a bond between the various societies interested in the subject. The Institute has now been founded by the co-operation, in the first instance, of the Faraday Society, the Optical Society, and the Physical Society of London, while the Royal Microscopical Society and the Röntgen Society have since decided to participate. In opening the proceedings, the first President, Sir Richard Glazebrook, said that the work of the physicist would become more and more important in the future, both in pure and applied science, and one of the aims of the Institute was to accelerate a recognition of the physicist's position and value. Many developments in physics had been of vital importance during the war, but men who had done important work as physicists could only be given an official status in some cases by being termed research chemists. He added that the membership of the Institute was already about 300, and comprised most of the leaders in physical science. Sir J. J. Thomson, who, it was stated, was willing to be nominated as president for the next year, gave a brief address. He said that to one who regarded chemistry as a branch of physics it was rather anomalous that hitherto there should have been an Institute of Chemistry and not an Institute of Physics. He had been a student of physics for fifty years. At the beginning of that period physics was like an army with great generals but few troops. There were at that time perhaps a dozen laboratories in the country. Opportunities multiplied rapidly, however, and students with them, and salaries also increased so that physics now offered to every competent man a livelihood though but small hope of a fortune. To-day the demand for competent physicists exceeded the supply. Research was expensive for the student and for the university, and perhaps this fact was not sufficiently recognized, although more money was available for research now than ever before. He saw no disposition to neglect or undervalue pure research, undertaken without any thought of an industrial application, and he congratulated the Institute on representing a profession which not only contributed so largely in various ways to human comfort, but aided the intellectual development of mankind. The Right Hon. A. J. Balfour extended a cordial welcome to the Institute. He had been greatly surprised to learn that there was not already in existence an institute of physics. After all, physics was the most fundamental of all the sciences. Whatever a man's line of research might be, if he could find a physical explanation for the phenomena he was examining, then, and then only, could he hope for something like finality in his investigation. It was certainly surprising that in this country, which had not lagged behind any country in the world in the great advances it had made in regard to the physical knowledge of the universe, they had not had an institute of physics before now. He confessed that when he saw vast disputes proceeding with regard to the distribution of the

results of industry, he wished that half the money and half the energy so expended could be devoted to increasing the power of man over Nature, thereby enlarging the total to be distributed. His memory went back to his days at Cambridge and to giants like Kelvin, Stokes, and Clerk Maxwell, who turned knowledge to such practical account. The mere growth of laboratories and multiplication of students would not produce men of that calibre, for genius came by itself and could not be cultivated or produced to order by any system of education. That rather chilling observation, however, did not settle the question, for if great discoveries were to be made both money and organization were required, and it was a griet to him that the Treasury was reluctantly compelled to cut down its allocations. He was often surprised that the imagination of some of the great magnates was not stimulated by the idea that by aiding research they could add to the wealth of the world. When one reflected upon the changes such discoveries had made in the lot of mankind it was amazing that more was not done by men who did not lack the spirit of liberality or the means of exercising it. It must be due—Mr. Balfour suggested—in part to an imperfect apprehension of the facts, and in part to that fatal desire to see immediate results for ontlay. Whatever added to knowledge of the universe could not fail sooner or later to contribute materially to the happiness of mankind.

TUBERCULOSIS IN THE CANADIAN FORCES.

A BOARD, consisting of five of the best known tuberculosis consultants in Canada, appointed by the Canadian Department of Soldiers' Civil Re-establishment, has investigated all the sanatoriums throughout Canada where ex-service soldiers are receiving treatment, and has presented its report.¹ In most instances these sanatoriums are also used for civilian patients, and ultimately will be used entirely for them. The number of men who entered the Canadian Expeditionary Force was 590,572, and 8,571 were treated by the department down to the end of April, 1920: this gives an incidence rate of 2.5 per 1,000 yearly for the 5½ years considered. The average number of Canadians under arms throughout the period of the war, with deductions for dead and missing, has been estimated at 317,000. The annual incidence rate, therefore, is more fairly based upon this number, and is 4.7 per 1,000. Since 8.6 per cent. of the patients treated in sanatoriums were diagnosed as non-tuberculous, 0.4 per 1,000 should be deducted, leaving 4.3 per 1,000. This rate of 4.3 per 1,000 may be considered as the corrected incidence rate; but these cases are further divided into bacillary positive cases, 1.9 per 1,000, and clinically tuberculous cases, 2.4 per 1,000. The incidence rate of tuberculosis in the British Forces, with corrections for the annual average under arms, is 1.07 per 1,000 yearly. It is understood, however, that in Britain the presence of bacilli was necessary for a diagnosis of tuberculosis; so that, instead of comparing the rate of 2.5 per 1,000, similarly obtained from the Canadian Forces, with the British rate, a crude rate for bacillary positive cases only should be used. 1.1 per 1,000. The incidence rate is, therefore, approximately the same in the two armies; but in Canada 1.4 per 1,000 were treated in addition as being probably tuberculous. A comparison between the incidence of tuberculosis in the army and civil life can only be made approximately, as too short a time has elapsed for the death rate from tuberculosis in the army to become reliable for comparison with the civilian death rate. Broadly speaking, however, it is estimated that there has been twice as much tuberculosis among the ex-service men of the Canadian Expeditionary Forces as amongst civilians of the same age period (20-44). The sanatoriums in Canada, the report states, had a hard struggle to become efficient, since the compelling need of

expansion for the many who demanded admittance had hitherto restrained improvement of facilities for treatment and the equipment needed, especially for the development of high standards of diagnosis. One of the real benefits of the war, therefore, is the great increase in sanatorium capacity because of the participation of the Canadian Federal Government; for while the civilian far too often is not treated for the disease, the ex-service man must be treated. Not only has accommodation been more than doubled, but all institutions which enjoy Federal assistance are much more highly efficient because of improved equipment as well as enlargement. The methods of treatment in vogue comprise all generally accepted as sound at the present time: A maximum out-of-door life through the facilities provided, adequate nursing, an ample dietary, food and diet supervision by trained dietitians, regulation rest and exercise, artificial pneumothorax, tuberculin, heliotherapy (both natural and artificial), dental treatment, and occupational treatment. From its investigations the board of consultants which issues this report is of opinion that a great constructive work has been done by the Government of Canada on behalf of her tuberculous ex-service men in a broad and sympathetic manner, and that a real and needed stimulus has been given to the whole antituberculosis work in Canada.

HOSPITAL FOR FUNCTIONAL NERVOUS DISORDERS.

SIR ERNEST CASSEL has founded and endowed a hospital or sanatorium for the treatment of functional nervous disorders. The upkeep of the institution and the treatment of patients has been largely provided for by the generosity of the founder, who has devoted £225,000 to the objects in view, but a charge will be made to each patient as a contribution to his or her maintenance. A fine mansion and park has been purchased at Penshurst, and the house has been reconstructed to accommodate sixty patients. It is primarily intended for members of the educated classes unable to meet the heavy expenses of care and treatment in a nursing home. We are informed that by the term "functional nervous disorders" will be understood those common but complex and distressing conditions which are not the direct outcome of organic disease. Among such may be named neurasthenia, nervous breakdown, loss of power not associated with evident structural changes, together with those manifold kindred troubles which are loosely termed "nervous." Largely, as is believed, the result of the stress and turmoil of modern life, they are unfortunately of great frequency and are accompanied by much suffering, and followed not uncommonly by disastrous mental and physical consequences. They are amenable to medical treatment under favourable conditions, but the facilities for such treatment hitherto existing have been altogether inadequate; it is to provide such means of cure and further to expand and elaborate them that the new institution has been founded. Their Majesties the King and Queen have graciously consented to become patron and patroness of the hospital. The members of the General Committee, under the chairmanship of Sir Ernest Cassel, are Sir Robert Haddon, Sir Courtauld Thomson, Sir Felix Cassel (the trustees of the fund) and Mrs. Joshua, together with the members of the Medical Committee, Miss Aldrich-Blake, M.S., Dr. Farquhar Buzzard, Sir Maurice Craig, Lord Dawson, Professor J. S. Haldane, Dr. Henry Head, Dr. A. F. Hurst and Sir Frederick Treves. Dr. T. A. Ross has been appointed medical director. The hospital will be ready for the admission of patients on May 23rd. Application should be made to the Medical Director, Cassel Hospital, Swaylands, Penshurst, Kent.

GARDENING FOR THE BLIND.

At the first glance the difficulties in the blind adopting gardening as an occupation may seem insurmountable, but from the evidence which has been collected it is clear that

¹ Summary of Report: Board of Tuberculosis Consultants. Ottawa: Thomas Mulvey, 1920.

many of them can be overcome, and that the effort of overcoming them is in itself a valuable educational exercise for the blind. Most blind gardeners need someone at hand to help or guide, but there is one blind gardener at least who carries on his work alone, cultivating the ordinary vegetables of a market garden, fruit (such as apples and plums), and grapes and tomatoes, in a small span-roofed house, sending the produce to the market by carrier and dealing with the wholesale buyers. Another blind man is a small farmer who has brought up a family by his own exertions, while another is a successful florist. At Chartres, in France, the blind soldiers at the professional school which has been established there cultivate their own garden; it is now not only one of the most beautiful in the neighbourhood, but has carried off the prize for the best vegetable plot in the Chartres military area. From the financial point of view, save in a few exceptional cases such as these mentioned, it cannot be expected that a blind person can make a living by gardening, but the material benefit is not the only aspect that ought to be considered in the promotion of gardening among the blind and partially blind. The occupations from which blind persons can gain a livelihood are in the nature of the case mostly of a sedentary kind, and the physical, and even more the psychological, aspects of gardening as a recreation must be very great, while the material benefit is by no means negligible. A meeting will be held at the National Library for the Blind, 18, Tufton Street, Westminster, S.W., on Thursday, May 26th, at 5.30 p.m., to further the interests of the Guild of Blind Gardeners, the object of which is to encourage the blind to undertake gardening as a healthy and interesting occupation. Colonel R. H. Elliot, who is chairman of the Naval and Military Committee of the British Medical Association, will be in the chair at this meeting, and any communications should be addressed to the honorary secretary of the Guild, Mrs. Reginald Wombwell, 54, Hamilton Terrace, N.W.8.

THE MAYO CLINIC.

THE Mayo Clinic at Rochester, Minnesota, has often been described, and there are probably few medical men in Great Britain who are not familiar with it as a great surgical centre which has grown up under the direction of Drs. W. J. and C. H. Mayo. It is not so generally known that within recent times a medical side has been organized on a large scale. We are told that approximately 60 per cent. of the patients now going to Rochester are medical. Altogether there are eight hospitals, with a total of probably something over 2,500 beds. Recently 100 beds were set aside in one of the hospitals for the study of diabetes and nephritis under the direction of Drs. Rowntree, Fitz, and Norman Keith. The permanent medical and surgical staff of the Clinic numbers about one hundred, but the total is raised to some three hundred by these who are working under the three years' fellowship scheme, which was explained by Sir Humphry Rolleston and Mr. Waring in our column last June. The Mayo Foundation for Medical Education and Research was established by the Mayo brothers on a permanent basis in February, 1915; shortly afterwards an agreement was made with the University of Minnesota under which the funds and income of the Mayo Foundation are devoted, under the direction of the Regents of the University, to the promotion of graduate work and research in medicine. The association with the University has since become more intimate, and the funds and income of the Mayo Foundation have been transferred to the Minnesota University, together with the staff, clinics, laboratories, library and records at Rochester. Entrance to the graduate school at Rochester is not limited to graduates of the Minnesota University, but an applicant must have a bachelor's degree in arts or science, an M.D. degree from an accepted institution,

and a year's experience as resident in an approved hospital or in a laboratory. The endowment provides fellowships and scholarships. Fellowships in internal medicine have recently been advertised in our column; they are for three or more years and are described as carrying "living stipends" and providing for both clinical study and research. The report we published last year stated that there were then about seventeen teaching fellowships, of the value of 600, 750, and 1,000 dollars for the first, second, and third years respectively, and eighty-six non-teaching Mayo fellowships, of which sixty were then in clinical and experimental surgery and twelve in clinical and experimental medicine. The full course leads up to the degrees of Master of Science (M.S.) or Doctor of Philosophy (Ph.D.) in medicine, surgery, ophthalmology, obstetrics, pathology, and so on. In the first year, spent mainly in the laboratory, the Fellow whose major subject is, for instance, surgery, works also at a minor subject, such as pathology; in his second year he finishes his minor subject, and passes an examination in it and in French and German, and devotes himself to his major subject; in his third year, if a surgeon, he works in the operating theatre, is in charge of the junior assistants, and writes a thesis. The organization for graduate study seems to be on a larger scale, thanks to the Mayo Foundation, at the University of Minnesota, than at any other American university, but it is far more elaborate at Philadelphia and Harvard than anything dreamed of in this country. The special degrees granted by the Universities of Pennsylvania and Harvard, as by the University of Minnesota, appear to be intended mainly for candidates who wish to prepare for a special line of practice immediately on the conclusion of the general course by which they obtain the degree of M.D. The University of Minnesota confines the adjective "post-graduato" to the revision or "refresher" courses taken some considerable time after graduation. Such courses are provided at many centres and are highly popular both with general practitioners anxious to keep their knowledge up to date and with others, "partially prepared clinical specialists," who wish to improve their knowledge of some particular line of practice.

HOSPITALS AND THE INCOME TAX.

LAST November the Executive Committee of King Edward's Hospital Fund for London appointed a subcommittee to consider the question of securing exemption from income tax for contributions to voluntary hospitals, thus providing a form of State assistance to them. This subcommittee, which consisted of Sir Walter Trower (chairman), Sir Basil Mayhew, Mr. H. L. Hopkinson and Mr. J. G. Griffiths, has now issued its report. Several alternative schemes were considered, and eventually one was adopted as a practical proposition. It is recognized that the greater part of hospital subscriptions and donations have been subjected to income tax, and, as part of the income of a hospital is exempt from taxation (under Schedule "C," interest on dividends, etc.) on the ground that it is applied to charitable purposes, the present position is obviously anomalous. It is suggested, therefore, that the Revenue should be empowered to give relief in respect of income tax borne by any subscription or donation to a hospital in such a manner that the institution and not the individual should benefit. For this purpose it would be necessary for a claim to be made by the hospital, supported by a certificate by the donor stating that income tax had been paid on the subscription, the amount being limited to a certain proportion of the donor's income, in order to ensure that the relief should be out of income as distinct from capital. The subcommittee considers that this scheme could be restricted so as not to embarrass the National Exchequer; that it offers a definite form of financial relief to the hospitals; and that it does not involve any question of

control of the management of the hospitals by the State. It recommends that its report should be placed before Lord Cave's committee, so that it may take this particular form of State assistance into consideration. Sir Walter Trower dissented from the subcommittee's report and presented a minority report, in which he expressed the opinion that the scheme was inconsistent with the report of the Royal Commission on the Income Tax, of which he was a member, and that it involved a direct grant by the Crown, which would raise the question of State control. He agreed, however, that if Lord Cave's committee considered that the principle should be recommended the proposed scheme was the best means of carrying it into effect. It is calculated, on the basis of approximate figures for 1920, that the sum obtainable by the London hospitals in the way recommended in this report as a refund from the Revenue might amount to £191,000. In this way their difficulties would at least be somewhat alleviated.

NORTH EUROPEAN CONFERENCE ON VENEREAL DISEASE.

THE first of the Red Cross regional conferences on venereal diseases to be held in Europe will meet at Copenhagen on Friday, May 20th, under the auspices of the League of Red Cross Societies. The Danish Red Cross Society will act as host and convener of the conference. The national Red Cross Societies of Great Britain, Holland, Norway, Sweden, Germany, and Finland have been invited to send delegates, and it is expected also that the Governments of the countries concerned will be represented. The business before the conference will include a general summary of the conditions in each country and an account of the medical measures and educational measures taken against venereal diseases. Special problems will also be discussed, including the supply and cost of arsenical compounds for the treatment of syphilis, the possibility of establishing an international standard for such compounds, and the provision in important ports, by international agreements, of treatment for cases of venereal diseases among sailors. The part the Red Cross should take in combating venereal diseases, and its relation to Government and voluntary agencies, will also be considered. The League of Red Cross Societies intends later to arrange regional conferences in other parts of Europe and subsequently in other parts of the world.

SERVICE CANDIDATES.

THE members of local authorities and their officers responsible for the correspondence with candidates for vacant appointments are no doubt anxious to treat them with all consideration, but we have reason to believe that they would do well to look into the manner in which their desires are carried out by subordinate officials. The handling of copies of testimonials may seem a small matter, but to a man who is earning nothing the cost of getting testimonials typewritten is of moment. The mortification of not obtaining an appointment is aggravated by failure to receive back copies of testimonials, which can be of no use to the authority, though they may serve the candidate's turn again. In one recent case in which the testimonials were returned the candidate, we are told, had sent an envelope stamped with a 2d. stamp; he received the testimonials back in an open envelope with a ½d. stamp, so that somebody seems to have made 1½d. out of him. There are other minor matters that might be mentioned, but the real question is whether the promise that men who had served in the war should receive special consideration after demobilization is being fulfilled. It is hardly enough to say that, other things being equal, a man who had served should have preference; if he has qualified himself for the post he deserves special consideration, even though he labour under some minor physical disability attributable to wounds or exposure suffered while on military service.

SIR JAMES MACKENZIE will give his lecture in the course at the Institute of Pathology and Research, St. Mary's Hospital, London, on Thursday next, May 12th, at 4.30 p.m. The thesis he will sustain is that "The opportunities of the general practitioner are essential for the investigation of disease and for the progress of medicine." On the following Thursday, May 19th, Professor H. H. Dale, F.R.S., Director of the Department of Biochemistry and Pharmacology of the Medical Research Council, will give a lecture on "Anaphylaxis and Immunity."

Medical Notes in Parliament.

[FROM OUR PARLIAMENTARY CORRESPONDENT.]

The Tuberculosis Bill.

THE second reading of this bill was taken in the House of Lords on May 3rd, being moved by the Earl of Onslow, the new Parliamentary Secretary to the Ministry of Health. Lord Strachie, for the County Councils Association, approved the measure, but asked for a clause to give statutory effect to the Government promise that the county councils should have a grant equivalent to that paid to the Insurance Committees last year, and 50 per cent. of the additional expenditure. Lord Onslow said that the Government was providing £2,000,000 to reimburse these councils, and this year another million sterling. This gift of a million was final, but the £2,000,000 would more or less depend on what the county councils spent on approved schemes during each year. There was no division on the second reading.

The Dentists Bill.

Sir Watson Cheyne, who has returned to the House of Commons after an absence due to illness, presided over a meeting of the Medical Group on May 2nd, when a deputation attended from the British Dental Association to confer as to the Dentists Bill. The terms of that measure, introduced by Dr. Addison while he was Minister of Health, have already been stated. The discussion showed that, while there is desire for legislation, there is still some difference of opinion as to what should be done.

Local Rates (Increase Prevention) Bill.—A private member's measure, entitled "Local Rates (Increase Prevention) Bill," introduced by Lieut.-Colonel Royds, was considered for second reading on April 29th. The first clause would require every local authority to set up a statutory financial committee of not more than one-fourth of the total membership of the local authority, and would lay down that no liability beyond £50 should be incurred without the sanction of this committee. Clause 2 would transfer from the Minister of Health to the Treasury all the powers at present held by the first-named department in relation to property and loans of local authorities. Clause 3 sets forth that there shall be an investigation by the Finance Committee of the County Council of the total county local expenditure every year. Clause 4 defines local authorities to which the Act should apply as meaning any county council or county borough council of any municipal borough, the council of any metropolitan borough, any district council and any board of guardians. Mr. Petyman seconded the motion with some important qualifications, and Mr. Myers, for the Labour Party, moved its rejection. Mr. Neville Chamberlain, seconding the amendment, said that the limitation of £50 was absurd, seeing that the great county boroughs and many municipal boroughs conducted gas, water and other undertakings. Indeed, the only effect could be that the Finance Committee of the corporation would have to vote a lump sum to each of the spending committees. Sir A. Mond, the Minister of Health, said the Government could not accept Clause 2, and if it were persisted in they would oppose the measure. He pointed out that the Ministry's work in sanctioning local loans was not merely that of a financier, but that inquiries were held by officials with technical knowledge. It was evident that if this function were to be transferred to the Treasury it would have to take over a very large portion of the staff and the duties of the Ministry of Health on the technical side. It was a function which the Treasury was not anxious or ready to undertake. He could not imagine that local authorities, having with some trouble convinced the Ministry of Health of the justice of their demands, would welcome being asked to repeat the whole process a little further down the street. Holding that the proposal was undesirable, Sir A. Mond referred to the list of sanctions of the Ministry of Health in England and Wales during the year ended March 31st, 1921, for purposes other than housing. He took the medical services, about which so much had been said by a certain section of the House—tuberculosis, sanatoriums and dispensary purposes, £432,000; maternity and child welfare purposes, £118,000; venereal disease hospitals,

£65,000; total, £615,000. The Ministry of Health had to sanction loans for schemes originating within the purview of the members of the local authorities, which were certainly not stimulated by the Ministry of Health, to the extent of £21,336,000, and the total amount of any schemes for which it might itself be responsible was £600,000. Had anybody ever seen a more inverted pyramid on which to base an argument, or a better case of putting the cart before the horse? Captain Fitzroy, on behalf of the supporters of the bill, stated that Clause 2 would be abandoned altogether if the Government would withdraw opposition to the second reading, and on this assurance Sir A. Mond withdrew his opposition, and on a division the second reading was carried by 96 votes to 60, and was committed to a Standing Committee.

Ministry of Health: Medical Branch.—Sir Keith Fraser asked, on April 29th, what necessity there was for the increase in the number of medical men on the public health staff in the direct service of the Government, from 39 who performed the functions under the Local Government Board in 1914, to 100 at present employed by the Ministry of Health, at an annual cost which was increased from £26,871 15s. 9d. in 1914 to £130,650 2s. in 1920; and whether the Minister of Health proposed to take any steps to reduce the numbers and cost. Sir A. Mond replied that he was inquiring into the functions and numbers of the medical branch of the Ministry, and, pending the result of these inquiries, had given instructions that no vacancies arising in the medical branch were to be filled.

Medical Staff of the Ministry of Health.—Sir J. D. Rees, having, on May 2nd, been referred to a previous reply by Sir A. Mond as to the suggested reduction of the staff of doctors maintained by the Ministry of Health, now asked whether thirty doctors were not appointed just before the House rose, and whether this expense was not affecting the health of the taxpayer. Sir A. Mond replied that his health was not affected, though the amount of money in his pockets might be. Sir J. D. Rees: Is it not the case that if a man's pocket is affected too much it very prejudicially affects his health? Sir A. Mond said his medical advisers did not agree with the hon. member; the latter retorted that that was because they got their jobs.

Pensions Medical Boards.—Taking up an inquiry by Mr. Watson, on April 28th, whether there had been any joining together of Medical Appeal Boards, Mr. Macpherson said there had not. He thought that what Mr. Watson had in mind was an administrative arrangement whereby, in certain large areas, a number of boards might be grouped for supervision under one Deputy Commissioner for Medical Services, each board, however, retaining its own chairman.

Re-vaccination for Small-pox.—Mr. F. Green asked, on April 28th, whether, in view of the statement in the annual report of the Chief Medical Officer of the Ministry of Health for the year 1919-20 that cases of small-pox did not occur after recent re-vaccination, the Minister would state how recent vaccination should be in order to be absolutely protected, and what were the characteristics represented by the word "successful." Sir A. Mond said he was advised that the protection against small-pox infection by efficient vaccination was practically absolute during the early years following the operation, and that in the great majority of cases the protection remained effective up to the tenth or eleventh year after vaccination. The evidence of successful vaccination was the production at the seat of inoculation of the characteristic lesions followed by well-defined marks.

Economical Foods Pamphlet.—Sir A. Holbrook asked, on April 28th, when it was proposed to issue the educational food leaflet, the draft of which was submitted early in March, with a memorial on this subject from medical, scientific, health and other associations, and would he deal with the matter as one of urgent importance, having regard to the present general distress and the consequent necessity for disseminating knowledge of healthy, nourishing and economical foods. Sir A. Mond replied that the matter was receiving attention, and he would see whether any useful purpose could be served by issuing such pamphlet.

Indian Medical Services' Appeals.—Mr. Montagu, in answer to Major Glyn, on May 2nd, said that officers of the Indian Medical Service had no right of appeal under Section 42 of the Army Act, but had a right of appeal to the Governor-General under Section 180 (2) (d) of that Act. If dissatisfied with his orders, they might then appeal to the Secretary of State for India, and through him to His Majesty the King.

Veneral Disease amongst Seamen.—Mr. Simon asked, on April 26th, whether the Minister of Health was aware that British seamen still suffered under disabilities unshared by their fellow-countrymen or foreign seamen in being penalized if they sought treatment for venereal disease, and that the British representatives at the meeting of the Health Section of the League of Nations were advocating international facilities for the free treatment of seafarers; and if the Government would consider the desirability of amending the Merchant Shipping Act, 1906, Section 34, Subsection (1), as desired by all interests concerned. Sir A. Mond said that the same facilities as were provided in British ports for the treatment of seamen suffering from venereal disease were not available in many foreign ports. This matter was under consideration by the Committee of the Office International d'Hygiène Publique, and would in all

probability be dealt with by the International Health Organization now being established under the League of Nations. The Minister promised to consult the President of the Board of Trade as to the last part of the question.

The Spallinger Treatment for Consumption.—Mr. Higham asked, on May 2nd, whether the Prime Minister would consider the advisability of appointing a Commission to investigate at once the merits of the Spallinger treatment for consumption, particularly in view of the fact that eighteen persons were treated in England with this treatment in 1913-14, when they were in the third degree of consumption, and to-day these persons were well and able to continue their occupations. Sir A. Mond, replying, said that the question of the merits of the Spallinger treatment had been under consideration by responsible medical authorities in this country since 1913, and during the last few months the Ministry of Health, following their usual practice of investigating the efficacy of all new methods of treatment for tuberculosis, had given further special attention to the matter at the particular request of M. Spallinger. The serum itself and reliable details of the clinical evidence in support of its use were not forthcoming. An undertaking had, however, been given that when supplies of this serum became available for independent and scientific investigation in this country, the Ministry of Health would facilitate an exhaustive examination of its efficacy. The appointment of a Commission would not appear to be of any advantage at the present time. He thought it desirable to emphasize that in the opinion of his medical advisers there was not yet available a sufficient body of evidence to justify the claims made for this treatment.

MEMORIAL TO SIR VICTOR HORSLEY.

THE following further subscriptions have been promised or received on behalf of the memorial to the late Sir Victor Horsley, C.B., F.R.S., particulars of which were published in our issue of January 1st, p. 19, and February 19th, 1921, p. 281:

THIRD LIST OF SUBSCRIPTIONS.

Acknowledged in previous lists, £306.

23.—L. N. S. Scott.

24.—Dr. J. S. Risien Russell.

25.—Dr. Janet Lane-Clayton, Dr. Foster Kennedy (New York), Dr. Herbert Spencer, Dr. Charles Hamilton, G. G. Turner, Percy Fleming, Dr. N. S. Finzi, Sir William C. Bister, Bilton Pollard, L. Gordon Hopkins, J. H. Parsons, F.R.S., Dr. Dennis Lambton, Society for the Prevention of Hydrophobia, per F. W. Fletcher.

26.—H. J. Spratt, John Dilloo.

27.—Anonymous (per Dr. Fatty Shaw), Dr. Hyde Marriott, Miss P. Whitaker, Dr. T. R. Elliott, F.R.S., Dr. A. M. H. Gray, Dr. T. H. Ionides, Dr. G. E. Waugh, Dr. Amand J. Gouth, Sir John Williams, Bt., G.C.V.O., Dr. R. H. Marten (Adelaide).

28.—Professor Winkler (Trecht).

29.—Dr. E. D. D. Davis, Dr. Byron Branwell, Dr. E. Deane's, W. Gilbert Nash, Professor Sir E. Sharpey Schafer, Dr. H. C. G. Semon, Dr. A. G. Phear, Sir John Tweedy, J. W. E. Brock, Charles Brook, A. J. Blaxland, S. B. Gadsby, Dr. F. Penrose.

30.—Professor W. W. Keen (Philadelphia), Dr. London (Adelaide).

31.—Sir James Barr, Dr. J. J. Powell, Charles Smith, Dr. E. B. Fennell, Miss Kirkaldy, Dr. Seymour Taylor, G. Hall, Dr. W. S. Sheldon, Dr. Howell Rees, D. Funnell, E. H. Young, E. A. Bullimore, Surgeon-Commander C. B. Fairbank, W. H. Paine, Dr. J. S. H. Roberts, Dr. S. Williams, O. P. Turner, Dr. C. D. Holdsworth, Dr. P. J. Le Riche, Dr. G. H. Hunter.

32.—Miss M. Breav, Miss M. K. Longfield, Dutch Branch of International League against Epilepsy, per Dr. Mikens.

Miss M. Lord, 5s. Mrs. Pitt, 2s.

Further subscriptions may be paid to either of the Treasurers, Sir Frederick Mott, K.B.E., Maudsley Hospital, Denmark Hill, Dr. H. H. Tooth, C.B., C.M.G., 34, Harley Street, or to either of the Secretaries, Sir William Arbuthnot Lane, Bt., 21, Cavendish Square, and Mr. Edward J. Donville, O.B.E., Symondsburly, Bridport.

DR. A. S. GUBB, formerly of London and now of Algiers, has written a small volume, with plans and illustrations, for the guidance of motorists in Algiers. The price is 5 francs; it is published by Jules Carbonel, Algiers.

THE late Alderman James Fildes, for many years chairman of the Manchester Public Health Committee, who died on February 3rd, has, among other gifts, bequeathed £1,000 each to the Manchester Hospital for Diseases of the Skin and the Manchester Royal Infirmary, and £500 each to the Hospital for Consumption and Diseases of the Throat, Deansgate, the Manchester Royal Eye Hospital, and the Manchester Surgical Aid Society.

THE second international post graduate course in Vienna will be concerned with surgery, orthopaedics, gynaecology, and diseases of children; it will begin on June 6th and last a fortnight. Another course in dermatology, ophthalmology, oto-rhino-laryngology, and urology will be given in December. Particulars can be obtained on application to the *Wiener medizinische Wochenchrift*, Wien, IX, Porzellangasse 22.

Scotland.

UNIVERSITY OF GLASGOW.

At a meeting of the Glasgow University Court on April 28th the secretary announced a bequest by the late Mrs. Torrance of Helensburgh of £1,000, free of duty, for the endowment of a scholarship in connexion with pathological research in the University, the scholarship to be known as the "Frederick William Perman Memorial." It was intimated that the Senate had approved a recommendation by the Faculty of Medicine that a special final examination in medicine for ex-service students only should be held in July. The Principal stated that the number of ex-service students was not yet exhausted, and that it would be a great convenience that they should be qualified before October.

STUDENTS' FEES AT EDINBURGH.

It was recently decided by the authorities of Edinburgh University that it was necessary to raise the students' fees in the different faculties, the increase varying from 33½ per cent. to 50 per cent. This has already come into operation in the faculty of medicine, the summer session of which commenced on April 27th. A student, however, who served in any branch of His Majesty's Forces is only required to pay the fees at the old rate. In the class of anatomy, for instance, the former fee was four guineas, which still holds good for ex-service men, but for all other students the fee has been increased to six guineas.

BOGUS DOCTOR IN GLASGOW.

At Glasgow Sheriff Court on April 25th Maurice Nathan, a young man said to be of respectable parentage, a clerk, pleaded guilty to a charge of fraud. In May and June, 1920, he had, under an assumed name, pretended that he was a surgeon in the Glasgow Western Infirmary and the Samaritan Hospital, and had treated a woman and her daughter. He supplied bottles of medicine which were coloured water, and he pretended, among other things, to carry out the operation of transfusing blood. His bills for treatment amounted to £14. In passing sentence of six months' imprisonment Sheriff Lee said that Nathan had pleaded guilty to a fraud of a most dangerous character.

New South Wales.

[FROM OUR CORRESPONDENT.]

HOSPITAL MAINTENANCE.

The question of hospital maintenance has again been brought prominently forward in connexion with the annual meetings of several of the public hospitals, and demands made for money for further extension and increased maintenance. The Minister of Health has asserted that the vote for the hospitals is exhausted and no money is available for any further extension of hospital buildings at present. He stated recently that objections were being raised to the nationalization of hospitals, and that the only way to prevent that was for the employers of labour to increase their voluntary contributions to an amount adequate to ensure the efficient maintenance and staffing of the hospitals of the State.

"The public hospitals," he argued, "are really for the benefit of the employers, for they exist to keep capitalistic machinery in order, and workers are part of the industrial machine just as is the plant which runs the mine or factory. The hospitals are really for the benefit of the capitalists and employers and they should maintain them. If they want the honour and glory of maintaining them by voluntary subscriptions well and good, but if they do not then the hospitals will be nationalized and the employers will not be asked for contributions but will have to pay for them by a levy in proportion to the number of labourers employed."

This statement was made in answer to a deputation which asked for an increased subsidy for a local hospital, and also for a capital grant for immediate alterations to the present buildings. The Minister stated further that the building fund of the Health Department was overdrawn to the extent of £50,000. The request of the deputation was not one for the workers, but for the mine owners, the

brickworks owners, the railway commissioners, and other employers whose workers benefited by the hospital. These same views have been set forth on other occasions by the present Government, so that they may be taken as the expression of the policy of the Labour Government with regard to hospital maintenance.

SYDNEY HOSPITAL.

After the recent annual meeting of subscribers to the Sydney Hospital, the new Maitland Lecture Hall was opened by His Excellency the Governor, who at the same time unveiled a memorial tablet placed there in honour of Sir Herbert Maitland, to whose efforts its erection was largely due. The hall has been built to accommodate 125 students, and there are at present 160 on the roll. The President stated that Sir Herbert Maitland had begun his association with Sydney Hospital in 1892, and in 1908, when it was made a teaching hospital, he was appointed the first lecturer in clinical surgery and had occupied that position ever since. It was recognized that from the work he had done and the eminent services he had rendered, this lecture hall should be named after him. Sir Herbert Maitland, in reply, stated that besides the function of relieving the sick and suffering the hospital was utilized for teaching the youth of Australia the elements of the medical profession. But another important function of the hospital was to inculcate in the students those qualities of sympathy and consideration for the sick without which a student was a misfit and had better be a hewer of wood and a drawer of water.

CHAIR OF PSYCHIATRY AT THE UNIVERSITY.

Hitherto the teaching of psychiatry at the University of Sydney has been in the hands of a lecturer, and although attendance at the lectures has been compulsory the subject has been an optional one at the final examination. As a result of a conference between the representatives of the Government Department of Lunacy and the University Senate it has been decided to appoint a Professor of Psychiatry at a salary of £1,100 per annum. The duties of the new professor have not yet been definitely settled, but it has been suggested that he should have the medical charge of Broughton Hall, which is attached to the Callan Park Mental Hospital, and is to be used as a hospital for the treatment of voluntary or uncertified patients. It is also suggested that he should have charge of an out-patient department at the Royal Prince Alfred and Sydney Hospitals, as well as access to all the mental hospitals.

Correspondence.

PREVENTION OF VENEREAL DISEASE.

SIR,—I have studiously abstained from controversy, and have for several months past, as letters in my possession prove, been engaged in frank and friendly discussion both with Lord Willoughby de Broke and other members of his society in an endeavour to end the schism that is doing much harm to the warfare against venereal diseases.

I feel bound now to point out to the public that two things only hinder the progress of negotiations: First, the sending of letters to the press by the same post as that by which they have been sent to me—a discourtesy which has twice taken place and makes frankness impossible; and, secondly, and more seriously, the undeviating way in which the *Times* has given publicity to Lord Willoughby de Broke's society and suppressed—or most misleadingly summarized—the attitude of the National Council.

An instance of its partiality occurred on the publication of the report of the Bishop of Birmingham's Committee. This was at once described by the *Times* as the case of the Society for the Prevention of Venereal Disease, a parenthetical comment which the most prominent member of that society admitted to me to be incorrect.

An even worse instance has just occurred: The *Times* has quoted at length from a letter sent to me by Lord Willoughby de Broke, and has not quoted—and has never done other than very briefly and misleadingly summarized—the definition of the National Council's policy to which Lord Willoughby de Broke's letter was in reply. It has refused to publish the letter I at once wrote, even though

I was drawing attention to action for which Lord Willoughby de Broke has subsequently expressed full and frank regret.

It is time the public understood the reason. No one can be impartial on a matter he has already prejudged, and the "Medical Correspondent" of the *Times*, who comes before the public anonymously as an impartial commentator, is a member of Lord Willoughby de Broke's Executive Committee.

In these circumstances I ask permission to state in your columns what I am refused permission to state in the *Times*—namely, that between the policy of the National Council as defined at our general meeting on March 22nd, 1921, and that of Lord Willoughby de Broke's society there is now admitted to be but one real point of difference; that lies in the inability of the latter to accept the following sentences of our definition of policy:

"Detailed official instructions as to the use of disinfectants in this connexion will, if issued to the public on sale with the disinfectants, not only have an appearance of official condonation, but also lead to the assumption that such disinfectants are an official guarantee to the purchaser against contracting disease; moreover, such instructions, unless followed with scrupulous exactness after definite and personal tuition in their practice, may lead to an aggravation rather than a diminution of the incidence of these diseases."

Nevertheless, these sentences express not merely the truth, but the truth which is daily receiving greater recognition, and I have no doubt whatever that even in spite of suppression and misrepresentation, truth will continue to prevail.

I am even hopeful that Lord Willoughby de Broke, who has been frank and courteous throughout all our conversations when allowed to speak through his own voice, will find the courage to shake himself free of the influences which are alone keeping the schism open, and so enable it to be harmoniously closed, to the great advantage of the campaign which we both have sincerely at heart.—I am, etc.,

(GORELL,
President.

National Council for Combating Venereal Diseases,
80, Avenue Chambers, Southampton Row,
W.C.1, May 2nd.

THE ETIOLOGY OF RICKETS.

SIR,—The abstract of an experimental investigation of this subject—carried out by Professor Noël Paton and Mr. Watson, and reported in the *JOURNAL* of April 23rd—traverses the current conception that rickets is a deficiency disease. It is a subject upon which an enormous amount of clinical experience must exist, and this, if it were focussed, might well resolve the problem, or at least indicate the lines upon which it might be resolved by experiment. So I am tempted to send you a clinician's view, in the hope of drawing others.

Some years ago, and for a good many years together, I saw a great deal of rickets at the East London Hospital for Children and as an assistant in the children's department at St. Bartholomew's Hospital. I came away with the conviction, unshaken since, that the cause of rickets is bound up with the eating of starch; that no diet, however faulty, will cause rickets unless it contains what is, for the individual, an excess of starch; and that, given such an excess of starch, rickets may occur in susceptible children although in all other respects the diet be perfect.

What constitutes an excess of starch is determined by individual peculiarity; for of two children in the same family and fed approximately on the same diet, one may be rickety and the other not. And this statement will probably be true of puppies also. Further, I have a firm belief that, apart from true and recognizable rickets, there is a common form of debility due to abundant starch-feeding, which affects children up to the age of 6 or 7. It is marked by a fat flabbiness and pallor, and a tendency to pot-belly, and responds splendidly to a diet from which carbohydrates are more or less excluded.

The teaching of my experience agrees pretty well with the results of the experiments under notice, but I do not know how to reconcile it with the claim that scrupulous cleanliness can obviate rickets when the diet is otherwise capable of causing it. If this be true it would seem that my clinical impressions must be at fault; but if they are supported by others, perhaps Professor Paton and his collaborator might be tempted to design some experiments

to test the rachitic influence of abundant starch-feeding, superimposed upon a diet previously proved to be non-rachitic.—I am, etc.,

London, W., April 27th.

W. P. S. BRANFORD.

THE CARE OF ARTIFICIAL EYES.

SIR,—The question recently asked by "Medicus" as to the means of removing the discoloration and dulling of artificial eyes, raises the more important question, How best to prevent such deterioration? The subject is of importance at the present time, as so many pensioners have to be supplied with them, and these have to be replaced when, from any cause, they become defective.

Breakages most often occur in the act of introducing or removing the eye from the socket. The obvious remedy is to perform this act with the head bent over a soft surface, such as the bedclothes.

The point, however, I wish to emphasize is that the discoloration and dullness of the eye which so frequently occurs can be prevented almost as easily. My father, who, although not a doctor, is a man of some little ingenuity, has had occasion to wear an artificial eye for over thirty-five years, and during that long period has only had to renew the eye six or seven times, and only on account of breakage. No discoloration or dullness has ever occurred. This, as well as the ease, comfort and freedom from irritation which he has experienced, he attributes, and I believe with reason, to a very simple practice which he adopted almost from the first. It consists in placing a little absorbent wool into the concavity of the eye and then smearing a very small quantity of a weak white boracic ointment on that part of the surface of the wool nearest the large end of the eye, so that when the latter is in position the ointment is nearest to the source of the lacrimal secretion. When the eye is removed at bedtime the wool is found quite saturated with fluid. The eye is placed in a small receptacle containing cold water, and kept there until required in the morning when the wool and ointment are renewed.

The advantages are: an absence of lacrymation, thus avoiding the constant wiping of the eye and its well-known evil effects upon the lids; the eye itself retains its natural lustre and life-like appearance, and is endowed with more mobility, the small amount of ointment used dissolving and spreading over it in a delicate film, which acts as a protection against the deleterious action of the secretions and as a lubricator facilitating the movements of the eye in association with those of the lids; the eye does not become discoloured or roughened, and hence there is not the same tendency to mechanical irritation of the conjunctiva.

As an ophthalmic surgeon I can recommend the above simple but effective practice.—I am, etc.,

ISAAC A. DAVIDSON, B.A., M.D.,
Assistant Surgeon, Ulster Eye, Ear
and Throat Hospital

Belfast, April 25th.

CELL ACTIVITY AND SPECIFIC DRUG ACTION.

SIR,—Many things suggest that in our treatment of disorder sufficient scope is not given to the activities not only of the leucocytes but of the fixed cells of the tissues. We would do well not to intrude too much on Nature's processes, but to observe and learn from her.

Certain foreign agencies are specially inimical to certain sets of cells. A poison administered in bulk to a healthy person will excite certain cells to make use of all their potentialities to meet it. An attenuated dose of the same poison will act in the same way, and will throw these same cells immediately on the defensive, their susceptibility being so delicate. In specific drug action we have a fine tool to use to excite rapidly specific cell activity, each poison finding its way straight to the cell in question.

With this end, and making a careful study of the various effects induced by various agencies, we choose a drug appropriate to the sum of the symptoms with which we have to deal—that is, a drug which, when given in bulk, would affect the cells which we observe to be affected in a certain disorder. We give an extremely attenuated dose, so as to be certain of doing no harm.

Superficially this practice resembles homeopathy; but the rationale of the matter is entirely different. The

cure, when cure results, is due not to the dose of poison—which even when most diminutive has not lost its specifically poisonous character—but to the vital response of cell-activity acting in self-defence. It is not the introduction of a "similar poison" which cures, but the reaction excited in the living cell against the superadded attack of a minute dose of a poison which has been proved to be capable of producing symptoms similar to those from which the organism has been suffering.

These minute doses are exceptionally effective when a chronic stage has been reached—that is to say, when the organism has become habituated to the presence of a deleterious agency. If we then introduce a diminutive dose of a poison which would in bulk single out the very sets of cells affected, the result will be to administer just the appropriate slight stimulus to excite to renewed activity cells which have become inert through a long period of unavailing resistance. The relationship existing between cell activity and specific drug action is at any rate one deserving of attentive consideration.—I am, etc.,
S. E. WHITE, M.B., B.Sc.

THE VALUE OF THE WASSERMANN REACTION.

Sir.—In your issues of May 29th and August 7th, 1920, two letters from myself appeared giving my reasons for warning practitioners against placing too great reliance on the Wassermann reaction. In the later of these I appealed to your readers to communicate to me such instances of unreliability that came within their experience, in order that sufficient evidence might be collected to prove conclusively that the "Wassermann reaction test, as employed at present, is not sufficient evidence alone on which to base a diagnosis of syphilis or to exclude this disease."

I received several replies giving instances of reports contradictory either in themselves or to the clinical evidence; but in the meanwhile my opinion, as expressed in your columns, in a medical contemporary, and in my manual, had received such confirmation by experienced authorities on venereal disease that it appeared evident that the unreliability of this test when unsupported by clinical evidence was now generally acknowledged and accepted, and that it was therefore unnecessary to trespass further on your space.

Marshall and French state: "There is a dangerous tendency at the present day to exalt the value of laboratory diagnosis and neglect that of clinical experience. A diagnosis based upon laboratory tests alone may lead to disastrous consequences both to the patient and the practitioner"; while McDonagh states, "I no longer attach the importance to the reaction which I once did," and "in my opinion it is useless to gauge the amount of treatment required, by the complement fixation test."

The Pan-American Congress on Venereal Disease that took place last year also put it on record that a negative reaction could not exclude syphilis, and that a positive reaction could not be accepted as conclusive evidence of syphilis. Wassermann himself more than ten years ago wrote: "If the reaction be negative, syphilis cannot be excluded absolutely but only with a probability of about 90 per cent.," and in 1912 I wrote: "Of all cases of syphilis examined from 80 to 90 per cent. give a positive reaction . . . different results are obtained with syphilitic lesions of different tissues."

In your issue of April 30th Dr. Kenneth Dickson records evidence that cannot fail to carry weight with all open to conviction, and asks for "the views of other workers on this subject, whether clinicians or pathologists." As one who has been fortunate in having the opportunity to acquire experience in both these fields of work, I should like to emphasize my opinion that the loss in confidence in the Wassermann reaction, resulting from a lack of knowledge of its limitations and occasional contradictions, is chiefly due to venereologists being either clinicians or pathologists, and not clinicians and pathologists.

Dr. Major Greenwood's letter, which immediately precedes Dr. Dickson's, points out with great common sense the folly and danger of rivalry instead of co-operation between the clinician and the pathologist. Quite recently in one week I had the following contradictory results, very similar to those recorded by Dr. Dickson:

1. Three children, aged 7, 5, and 3, were sent to me for treatment for congenital syphilis based on reports of strongly positive Wassermann reactions in all three by pathologist "A." I was unable to find any parental history suggestive of syphilis, or any history or clinical manifestations of syphilis in the children, and I therefore had the Wassermann reaction of the three children and the mother tested by pathologist "B," with whose technique I was personally familiar, and in whose work I have complete confidence. All were reported to be completely negative. I then asked pathologist "A" to repeat his test, and the children were now reported to be "weakly positive," but quite at the negative end of the positive series. In my opinion the three children were not syphilitic, and I refused treatment.

2. A neurasthenic patient with a history of a "sore on the penis" three months previously, which healed in a week with local applications only, and which was followed by no secondary symptoms, consulted me in the belief that he had had syphilis. From the history I was convinced that the "sore" was not syphilitic, but to satisfy the man tested his Wassermann reaction in order to allay all doubts in his mind. To my surprise the report of pathologist "B" was "strongly positive." I insisted on a second test, which was "negative," and the patient insisted on a third test, which was again negative. Here again I refused treatment. The possibility of mixing specimens could be entirely eliminated in this case. Both pathologist "A" and "B" were experienced and responsible men, and I have personal knowledge of the very conscientious and careful technique of the latter, who was quite unable to account for the contradictory result.

During the late war complete reliance was placed by the R.A.M.C. authorities in the positive Wassermann reaction, and from personal experience in army V.D. hospitals I am convinced that very many men were labelled "V.D.S." who were never infected by the *Spirochaeta pallida*. I consider the Wassermann reaction a very valuable confirmatory test if its limitations are appreciated, but a very dangerous test if it is considered pathognomonic.—I am, etc.,

London, W., May 2nd.

H. WANSEY BAYLY.

TREATMENT OF VENEREAL DISEASE.

Sir.—We beg to point out that the review of our book on *Syphilis and Venereal Diseases* in the JOURNAL of April 16th tends to convey a totally erroneous impression of the treatment we advocate for syphilis, and also contains some inaccuracies.

The paragraph quoted by your reviewer is not "a special plea" for the internal administration of mercury, but is intended to show that this method of treatment is not so inadequate as some would have us believe. Of the different methods of mercurial treatment we distinctly state that we regard inunction the most effective, but injection more convenient in practice. For the treatment of syphilis in general we recommend combined treatment by arsenical compounds and mercury injections.

With regard to the cases of exfoliative dermatitis, your reviewer is in error in stating that we have omitted to give details of the treatment given to these cases. If he refers to pages 230, 234, he will find this distinctly stated.

Again, the statement that only a few lines are devoted to tests for cure of gonorrhoea is also incorrect. Apart from the summary on page 412, and the comments on the complement fixation test on page 331, the question of cure is referred to in several parts of the chapter on gonorrhoea.

There is also given a full description of the use of the urethroscope in testing for cure.—We are, etc.,

C. F. MARSHALL.

E. G. FRENCH.

London, W., April 25rd.

*. The reviewer, to whom a proof of this letter has been sent, writes: "In stating that the authors made a special plea for internal mercurial medication, I did not accuse them of neglecting other remedies; I think they were quite right to stand up for 'pills.' I regret to have overlooked the details of treatment given on pp. 230 and 234. The suggestion that tests for cure in gonorrhoea might have received more attention is, I think, justified. Although scattered references to the subject may be found in the book, this point seems of such importance that these references should have been collected in the special section headed 'Tests for the Cure of Gonorrhoea' on p. 412. The fact that a reviewer has missed them suggests that they will escape the attention of other readers, whereas it should be impossible to read a modern work on venereal disease without having this subject forced on one's attention."

SAPRAEMIC GLYCOSURIA.

SIR.—I please allow me in your columns to thank Dr. Mitchell, Dr. Leyton and Dr. Cammidge for their comments on my paper on supraemic glycosuria: Dr. Mitchell for supporting my thesis by his record of two contrasted cases, one of supraemic glycosuria following carbuncle, the other of diabetic gangrene; Dr. Leyton especially for drawing attention to the connexion between supraemic glycosuria and pyorrhoea alveolaris (a subject worthy of a great monograph all to itself; and Dr. Cammidge for following up my last paragraph and so coming nearer to those great generalizations concerning glycosuria which are beginning to enlighten us already, and are likely soon to bring great improvement to our knowledge and practice.

2. In my chapter on the History of the Doctrine, I am sorry to say that, through sheer ignorance, I made no mention of the very fine monograph on "Glycosuria and Surgery" contributed by Messrs. Guy Bellingham Smith and Herbert E. Durham to the *Guy's Hospital Reports* of 1892, vol. xlix (published by Churchill in 1935). To me this very learned and competent monograph, nearly 100 pages long, ranks as a minor classic, and it ought, as such, to be reprinted. The authors divide cases of surgical lesions complicated by glycosuria into two classes: (A) Those where the lesion is the actual and direct cause of the glycosuria, and (B) those where the glycosuria precedes and is not dependent on the surgical lesion—for example, diabetic gangrene. Class (A) is divided into (i) toxic glycosuria and (ii) traumatic glycosuria. Toxic glycosuria is subdivided into (a) a *septic form*, in which the glycosuria is "determined by the influence of micro-organisms upon the system or upon individual tissues—for example, carbuncle, phlegmon" (this is what I call supraemic glycosuria); and (b) a form due to drugs such as chloroform, chloral, opium, morphine, etc. In this case the authors say "there is reason to believe that the reducing substance in many cases is not glucose but glycuronic acid."

"What we insist on here," say the authors, "is that glycosuria, accompanied or not with polyuria, albuminuria, etc., may, and frequently does, occur as the result of the lesion for which the patient is presenting himself, and by its presence may lead to a possible erroneous diagnosis of a past glycosuric condition, and thus influence prognosis. Another practical point, that specially interests us here, is whether the sugar is of ill omen for the future course of the patient as regards both his local and general condition." (P. 339.)

The history of the doctrine is carried by the authors much farther back than I have done. Prout in 1840 recognized that glucose might appear for the first time in a patient affected with carbuncle, and states that Cheselden in the eighteenth century recognized the same fact; Prout also declares that this matter is of great importance to surgeons, who commonly have to treat such cases. The authors, like Dr. Cammidge, refer to Prévost's thesis of 1877, and Redard's paper on "Ephemeral glycosuria in surgical affections" in the *Revue de Chirurgie* of 1886. They also quote Mr. Spencer's paper of 1892 (as I did); Sir Cuthbert Wallace's work had not then appeared.

3. In order to show what encouragement we are already receiving by the present-day reception of our doctrine, I cannot, of course, quote from the many kind and enlightened private letters that I have thankfully received from many great surgeons and physicians; but I am free to do justice to such textbooks as I have found correct and up to date in their teaching concerning supraemic glycosuria; the authors will surely allow me to express my desire (though that may be unnecessary) that they should in future editions amplify their brief remarks.

1. From *Choyce's System of Surgery*, vol. 1, p. 206, published in 1912:

"*Dry Gangrene*.— . . . Glycosuria is a frequent accompaniment of this sort of gangrene, and is probably due to the absorption of toxic products from the dead and dying tissues. It must not be mistaken for the glycosuria of diabetes, for it is unaccompanied by the classical symptoms of that disease, and passes off when the dead part is removed." (Article by Mr. Cyril Nitch.)

2. From Rose and Cutless's *Textbook of Surgery*, tenth and latest edition, p. 1294:

"An interesting form of glycosuria occurs in some infective conditions of the type of cellulitis (boils, carbuncles, etc.) where the presence of glucose in the urine appears to be secondary, and disappearance quickly follows effective operative treatment. The explanation of this condition is not at all obvious."

May we not infer from these extracts that the seed sown a generation ago by Prévost, Redard, Spencer, Godlee, Bellingham Smith, Durham, and Wallace, has at last almost come to full harvest?—I am, etc.,

Birmingham,

CHARLES GASKELL HIGGINSON.

DESCENT OF THE TESTIS.

SIR.—After working for a considerable time upon the problem of the descent of the testis, I am inclined to the opinion that the descent is conditioned by the fact that the temperature within the tunica vaginalis is lower than that of the general abdominal cavity.

There is an optimum temperature at which the spermatozoa are produced; the undescended testicle is aspermatic; the scrotum is a region most excellently equipped for the purposes of heat-loss.

In many groups of the animal kingdom the intimate relation between temperature and capacity for reproduction is established. The mechanism of the periodic ascent and descent of the testis in other groups indicates that the almost passive part ascribed to the gubernaculum testis is but a feeble reminiscence of the part it used to play.

The general teaching is that in cases of cryptorchism the testis does not descend because it is imperfect. Certainly, a malformed testis can be a mechanical cause of non-descent as may also an imperfection of the peritoneum, gubernaculum, inguinal canal, or scrotum. But since it is a fact that a normal testis when permanently transferred from the scrotum to the abdominal cavity assumes the histological characters exhibited by a testis which has never descended, it is obvious that the situation can be responsible for the imperfection—for the aspermatic condition of the testis. This is also demonstrated by the fact that if a retained testis can be drawn down into the scrotum without interference with its trophic supply and in the absence of irreparable imperfection of the accessory sexual apparatus it will become functional.

I feel that this line of investigation is worth pursuing further, and I shall be very grateful for information upon the following points:

1. What diseases so affect the skin of the scrotum that the sweat glands are destroyed? In such diseases is the testis aspermatic and the man sterile?
2. Are any data available of the temperature of the abdominal cavity and of the interior of the tunica vaginalis?
3. If an ovary descends to occupy a position within the labium majus, does it function?
4. What is the fate of auto-transplanted ovary and testis in unusual situations—superficial and deep?

According to the theory proposed above the answers to these questions are obvious. But my great need for the moment is facts which surgeons can give me.—I am, etc.,

Animal Breeding Research Department, F. A. E. CREW, M.B.
The University, Edinburgh,

April 27th.

DIFFERENTIAL STAINING OF CARCINOMATA.

SIR.—In reply to Dr. Shera (whose memorandum appears in your issue of April 30th, p. 639), I do not think that we have yet arrived at a differential stain for the essential cells of carcinoma. The method that he recommends does not differ materially from that in use in the large majority of pathological laboratories. In order to confirm this I have taken an axillary gland in an early stage of carcinomatous invasion and stained it meticulously observing his temperature and time. Concurrently with this I examined several carcinomata of the breast of varying degrees of malignancy. In the result I was unable to confirm the differentiation that Dr. Shera found, and on slightly varying the time and concentration and sample of haemalum it was possible to obtain entirely different results, as almost every variety of tone was obtained both with the nuclear and counter stains. Not only is there considerable difference between the staining reaction of the various types of haematoxylin and haemalum at present on the market, but also the colour can be modified by varying the time of immersion in tap water, with or without ammonia or sodium bicarbonate.

Does Dr. Shera depend on a stain for distinguishing between a leucocyte and an epithelial cell? It would

certainly appear so from his memorandum. The distinction between carcinoma and normal epithelium must still depend on the grouping of the cells, their relation to the tissue in which they lie, and the structure of their nuclei (to name a few of the most important points), rather than on a staining reaction which varies, *inter alia*, with the shop from which one buys one's haematoxylin!—I am, etc.,

London, W.C., April 30th.

A. KNYVETT GORDON, M.B.

PULMONARY AND AORTIC BLOOD PRESSURES.

SIR,—Dr. Harry Campbell, in his letter of April 9th, asks "the meaning of the great excess of the aortic over the pulmonary blood pressure (how comes it, for example, that the aortic pressure of the mouse is greater than the pulmonary pressure of the horse?)." The reason appears to me to be that the pulmonary circulation corresponds to an irrigated area, through which the water flows indifferently, whereas the aortic and general circulation corresponds to a town distribution, where the local requirements are variable.

Were the low pressure pulmonary system adopted generally the only way of increasing the circulation to a muscle in action would be by increasing the heart beat, which would affect all organs equally with the active muscle—a most undesirable result. By the high pressure system the supply to one part can be greatly increased with but a nominal effect on the rest. The arteries are elastic and overstretched that life itself may be elastic.

The high aortic pressure of the mouse is easily attained, because the left ventricle of the mouse is smaller than that of the horse. The inner surface of the mouse's ventricle has to press against the resistance of, perhaps, one square inch of blood; the horse's against many square inches, and, as I explained in my article of February 5th, the effort required does not increase as the diameter, nor even as the square of the diameter, but as the *cube* of the diameter of the contracting ventricle. The horse's ventricle is not large that it may raise a high aortic pressure, the mouse's ventricle can do that; it is large and thick that it may throw out a large quantity of blood at each stroke against a high pressure resistance; whereas that of the mouse is called upon to throw out a very small quantity of blood, against a similar high pressure resistance. A child can lift a brick a foot high, whereas it requires a man to lift a dozen simultaneously through the same height.

Incidentally it may surprise many to know that the pressure one puts into a bicycle tyre is about equal to that required for the tyres of a Rolls-Royce car.—I am, etc.,

Mentone, April 26th.

D. W. SAMWAYS.

PROSTATIC CONGESTION.

SIR,—Your correspondent, "Æt. 53," says that he suffers from "priapism at night, subsiding when the bladder is emptied." This I believe to be bad treatment. I had similar symptoms at his age, but believing that the pad of water in the bladder might, by its support, decrease local congestion, I strove to control the priapism by altered positions in bed, and often succeeded. The result is that now, when over ten years older, I can generally sleep the night through as comfortably as a boy, and easily pass water in the morning. Sometimes when I wake at night I feel a heavy, oppressive, prostatic (?) congestion, which is at once relieved by passing water. If I yield to the desire, when I wake later I commonly have priapism pretty acutely. If I resist, and soothe the congestion by several changes of position before again sleeping, I have no further trouble.

Perhaps the prostate can be trained to behave itself, like many another organ.—I am, etc.,

April 26th.

Æt. 64.

PHYSIOLOGY AND CLINICAL MEDICINE IN SHEFFIELD.

SIR,—I should like to add a few supplementary words to the interesting article in your last issue on "Physiology and clinical medicine in Sheffield."

In the first place, Professor Leathes holds the post of consulting physiologist, not only at the Royal Infirmary, as stated in your article, but also at the Royal Hospital. At each institution Dr. Inrie is in charge, under Professor Leathes, of the clinical physiological laboratories. This ensures identical conditions for students attending at either place.

As a matter of fact all the four voluntary hospitals in Sheffield have for some time been united for purposes of clinical teaching, under the control of a joint representative committee, and students of the medical faculty are allotted for various periods to each institution.

Personally, I believe that this harmonious co-operation of the staffs of the four voluntary hospitals in connexion with the Faculty of Medicine has indirectly been a factor in leading up to the spontaneous and generous action of the Medical Panel Committee which you record. Just as your article shows that the clinician and the laboratory worker have found there is a mutual advantage in coming more closely together, so there have been, latterly, many signs, in this area at any rate, that the gulf which has for so long separated members of hospital staffs from general practitioners may soon be bridged over. The generous action of the Medical Panel Committee of Sheffield has laid a solid foundation for one pier of the bridge, and with this excellent start I have no doubt whatever that the structure will soon be complete.

If such a *rapprochement* between hospital staffs on the one hand and general practitioners on the other can be realized here, there is no obvious reason why it should not be realized elsewhere. When such a thing once comes about it will require but little more to acquire all that is of real importance in the Dawson Committee's findings, and practically at very little cost.—I am, etc.,

University of Sheffield, May 2nd.

ARTHUR J. HALL.

Obituary.

HENRY EDWARD JULER, F.R.C.S.

Consulting Ophthalmic Surgeon to St. Mary's Hospital, London.

THE death of Mr. Henry Juler, after a long illness, removes one who was for many years a very familiar and well-loved figure among ophthalmic surgeons in London.

Henry Edward Juler was the son of Dr. H. C. Juler, and was born in Suffolk. He received his medical education at St. Mary's Hospital, and took the diploma of M.R.C.S. in 1867 and that of F.R.C.S. in 1879. He was at one time demonstrator of anatomy at St. Mary's Hospital Medical School and medical superintendent of the hospital; afterwards he resolved to devote himself to ophthalmology, and became pathologist to the Royal Westminster Ophthalmic Hospital, and later assistant ophthalmic surgeon to St. Mary's Hospital.

In a long professional life of over fifty-five years, he made numerous friends and no enemies. His kindness of disposition made him a most delightful colleague to work with. At St. Mary's Hospital, with which he was associated during the whole of his professional life, generation after generation of students came to know him and to regard him, even when he was very much senior to them, as a friend.

For over twenty years he worked at St. Mary's as a colleague of Sir Anderson Crichtett, and in the latter years of that time he was responsible for the whole of the out-patient work and the teaching of the hospital. When Sir Anderson Crichtett retired in 1901, Mr. Juler became senior ophthalmic surgeon to the hospital, and the post in which he had served for so many years was formally recognized by the creation of an assistant ophthalmic surgeon. It is pleasant to know that the post is now occupied by Mr. Juler's son, Mr. Frank Juler. As senior ophthalmic surgeon, Mr. Juler continued to work as assiduously, both in the out-patient department and in the wards, as he had in the previous twenty years.

Mr. Juler earned his reputation mainly as a clinician. His *Handbook of Ophthalmic Science and Practice*, first published in 1884, ran through three editions in this country, and was recognized in its time as one of the standard textbooks on the subject. An American edition was also published, based on the English one, but it was not credited to Mr. Juler's authorship, and the only acknowledgement he had of it was a beautifully bound gilt edged copy of it! Along with Mr. John Griffiths, he demonstrated the presence of the dilator fibres in the iris.

As president of the Harveian Society he delivered lectures on the syphilitic diseases of the eye, which embodied his experience gained by long connexion with the Lock Hospital in the Harrow Road. He was also a vice-president of the Ophthalmological Society of the

Licences to practise physic were granted to the following 103 candidates who, having conformed to the by-laws and regulations, had passed the required examinations:

Dulcie S. Adkins, S. E. Amos, L. H. Appleby, G. Armit, E. F. Back, E. T. Bailey, F. G. J. Barnes, G. M. F. Barnett, S. H. Barnett, D. E. Bedford, K. M. Bharucha, F. A. Bryning, Mary Burfield, S. B. Chambers, P. Coucaud, F. C. Cozons, H. A. Crowther, C. K. Cullen, C. B. Daisie, I. L. C. Deveney, I. G. de Zilva, C. F. T. East, K. St. V. Edwards, G. W. Elkington, R. W. Fairfax, S. Farris, Katherine M. L. Ganjee, A. J. Gardham, Janet K. Gatty, W. Gothe, J. B. Gregor, S. Grossman, A. B. Hacking, W. B. Hargreaves, Eleanor Harse, W. E. Hayes, S. S. Hewitt, J. W. Birst, R. W. P. Hosford, *Margaret O. Howell, B. L. Jeafireson, W. D. Jenkins, D. E. Jones, J. T. Jones, M. Kamil, G. W. Karunaratna, *Mary E. Kennedy, M. Koro, J. H. Le Brasseur, R. Lee-Michell, *Bessie Levio, C. G. Lewis, E. O. Lewis, W. B. A. Lewis, E. T. Lloyd, J. R. Lund, C. H. Macklin, *Dorothy McNair, *Henricetta A. C. Main, Sytze E. J. Miedema, *Sybil G. Mocatta, J. C. R. Morgan, B. S. Ni-sé, G. Noot, M. M. Ostrowick, R. J. Parry, T. F. Peck, F. A. Philipps, *Marjorie Pierce, Cassie E. Pratt, W. S. Ratnavale, H. L. Rayner, A. McK. Reid, J. Reith, *Edith M. Rooke, I. M. Rossiter, C. I. Schiff, C. G. Schoneboom, *Margaret Scott-Moorehead, G. S. Sinnatambay, H. L. Slaughter, *Elfrida E. A. Spencer, H. E. Suter, B. Tago, H. B. Taylor, H. W. Taylor, C. P. Thomas, E. W. C. Thomas, B. W. Thompson, F. H. W. Tozer, J. P. Traylen, Frances I. G. Tweedie, W. G. D. H. Urwick, *Mary G. Vaughan, H. S. Ward, Mildred Warde, Joan M. R. Warwick, J. F. Weakley, R. A. Webb, *Agnes E. Westwood, H. L. Willey, D. C. Williams, *Constance M. Willis.

* Under the Medical Act, 1876.

Diplomas in Tropical Medicine and Hygiene were granted jointly with the Royal College of Surgeons to the following twenty-one candidates:

J. O. Beven, F. X. Costello, A. Crawford, J. P. de la Va, W. M. Howells, Annie M. Mackay, C. T. Maitland, Mary Martio, M. Morrison, P. Parthasarathy, R. A. W. Procter, B. K. Ray, H. E. S. Richards, Mona M. Ross, C. L. Sahni, D. S. Scott, J. Ségal, L. Sen, P. N. Selb, R. G. Simpson, H. Smith.

Sir Norman Moore was re-elected a representative of the College on the General Medical Council.

Sir Wilmot Herringham was re-elected a representative of the College on the Senate of the University of London.

The Registrar gave notice that at the next College meeting he will move an addendum to the Regulation attached to By-law 217 (which prescribes the times of the several parts of the membership examination), as follows:

"Provided that when the number of candidates exceeds twenty, the President and Censors may fix such additional times for the clinical and oral examinations as may be required for the proper conduct of the examination."

Some formal reports were then received and the President declared the Comitia closed.

The Services.

R.A.M.C. FUND AND R.A.M.C. OFFICERS' BENEVOLENT FUND.

The annual general meeting of the Royal Army Medical Corps Fund will be held in the Library of the Royal Army Medical College, Grosvenor Road, S.W., at 2.30 p.m., on Monday, June 13th, 1921. The Director-General will preside. It is hoped that all subscribers who can spare the time will be present, and will freely express their views on any point connected with the fund.

The annual general meeting of the Royal Army Medical Corps Officers' Benevolent Society will take place immediately afterwards.

Any officers desiring information regarding these funds are requested to communicate beforehand with the Secretary, Lieut.-Colonel E. M. Wilson, 76, Claverton Street, S.W.1 (Tel. Victoria 2722), so that there may be no delay in dealing with any questions asked.

TITLES OF RETIRED OFFICERS.

IN mentioning recently the death of Deputy Surgeon General Oliver Codrington, who retired in 1886, he was referred to as R.A.M.C. (ret.). It was stated that he became brigadesurgeon in August, 1885, and retired with a step of honorary rank in March, 1886. A correspondent, who signs himself "K." asks whether the R.A.M.C. existed as long ago as 1886, and whether in the current *Army List* any R.A.M.C. officer can be found with such rank as deputy surgeon-general.

The Royal Army Medical Corps, of course, did not exist under that name in 1886. The medical service of the army was then and for long had been entitled the Army Medical Department (the A.M.D.). It became the Army Medical Staff in 1891, and the Royal Army Medical Corps in 1898 by the Royal Warrant of June 23rd, 1898. Our correspondent's point is, we presume, that it is incorrect to speak of any retired medical officer holding a medical or a compound title as an officer of the R.A.M.C. Strictly speaking, he is right in this argument; such retired officers should be called retired officers of the A.M.D., or of the Medical Staff as the case may be. But we think it is customary to speak of all retired medical officers as retired officers of the R.A.M.C., even though they retired before that corps title was given.

The monthly *Army List* does not give the names of retired officers. In the *Quarterly Army List* for January, 1921, the War Office official list, the name of O. Codrington is given among those of "Brigade Surgeons (with honorary rank of Deputy-Surgeon-General)." This list gives no retired deputy-surgeon-generals of the British Army, but gives the names of six under the I.M.S. The same list gives, for both services, the names of a number of brigade-surgeons, brigade-surgeon-lieut.-colonels, surgeon-lieut.-colonels and surgeon-majors, all titles which equally have long been obsolete as far as serving officers are concerned.

The titles deputy-surgeon-general and surgeon-general were superseded nearly thirty years ago by the titles of surgeon-colonel and surgeon-major-general and by those of colonel and major-general in 1898 and 1918 respectively. The title of surgeon-general was revived for twenty years, 1898-1918.

DEATHS IN THE SERVICES.

LIEUT.-COLONEL CHARLES GEORGE DRUMMOND MOSSE, R.A.M.C. (ret.), died at Weymouth on February 25th, aged 63. He was born at Kingston, Jamaica, on August 22nd, 1857, the son of the late Deputy Surgeon-General Charles B. Mosse, C.B., C.M.G., who entered the army in 1853 and died in 1912. He was educated in the medical school of the R.C.S.I., and took the L.R.C.S.I. in 1879, the L.K.Q.C.P. in 1880, and the F.R.C.S.I. in 1888. Entering the army as surgeon on February 5th, 1881, he became lieutenant-colonel after twenty years' service, and retired on October 17th, 1908. He served in West Africa, in India, where he was physician to the Maharajah of Dhar, at St. Helena, and in Jamaica, where he rendered valuable services during the great earthquake in 1907. After retirement he was employed as senior medical officer of the Guernsey and Alderney District, and subsequently by the War Office and the Ministry of Pensions until July, 1920, when his health completely broke down. He served with the Sherborough expedition on the West Coast of Africa in 1883, when he was mentioned in dispatches, and during the South African war, 1899-1902, was senior medical officer at St. Helena, receiving the Queen's medals. He is survived by his widow, the eldest daughter of the late Lieut.-Colonel John Peter Boileau, and three daughters and one son.

Lieut.-Colonel Albert Kirwan, R.A.M.C. (ret.), died at Hampstead on April 9th, aged 79. He was educated in Dublin, and took the L.R.C.S.I. in 1867 and the L.K.Q.C.P. in 1868; subsequently he took the F.R.C.S. Edin. in 1887 and the D.P.H. of the London Colleges in 1889. Entering the army as assistant surgeon on March 31st, 1868, he attained the rank of lieutenant-colonel after twenty years' service, and retired on October 26th, 1896. After his retirement he was employed at Leicester.

Surgeon-Lieut.-Colonel James Barker, R.A.M.C. (ret.), died in London on April 10th, aged 81. He was educated in Dublin, took the L.R.C.S.I. in 1859 and the L.K.Q.C.P. in 1860; he entered the army as assistant surgeon on September 30th, 1863, attained the rank of surgeon-major on April 28th, 1876, and retired on October 10th, 1888, afterwards receiving the title of surgeon-lieutenant-colonel when the compound titles were given in 1892. In the regimental days he served in the 1st Foot, the Royal Scots or Royal Regiment, and in the 41st Foot, the Welsh Regiment.

Captain Allan Noel Minns, D.S.O., M.C., R.A.M.C., died at Thetford, Norfolk, on March 6th, from the effect of injuries received in a motor accident on March 3rd. He was born in March, 1891, the son of Dr. A. G. Minns of Thetford; educated at Guy's, and took the L.M.S.S.A. in 1914. He took a temporary commission as lieutenant in the R.A.M.C. on September 26th, 1914, and was promoted to captain after a year's service. He took a permanent commission as lieutenant (temporary captain) in the R.A.M.C. on January 1st, 1917, and became captain on March 26th, 1918. He had been on active service abroad through the greater part of the war, including the campaign in Mesopotamia; was thrice mentioned in dispatches; in the *London Gazette* of October 29th, 1915, October 19th, 1916, and August 27th, 1918; and received the Military Cross on October 29th, 1915, and the D.S.O. on June 3rd, 1916.

Captain Robert Long Gamlen, Indian Medical Service (retired), died of blood poisoning at Dawlish on February 18th, aged 39. He was born on March 2nd, 1881, the third son of the late Mr. Leonard Blagden Gamlen, J.P., of Crediton. He graduated B.A. Camb. with second class honours in the Natural Science Tripos, and then went to St. Thomas's Hospital. He took the M.R.C.S. and L.R.C.P. in 1906, and graduated M.B., B.C. Camb. in 1908, and M.D. in 1912; he took the D.P.H. with distinction in the same year. After filling the posts of outpatient house-surgeon and resident house-surgeon at St. Thomas's, he entered the I.M.S. on August 1st, 1908, becoming captain after three years' service. He was placed on temporary half pay, on account of ill health, on November 24th, 1913, and invalided out of the service on August 28th, 1914. In the following year he rejoined for service, and served in the Pavilion Hospital for Indian soldiers at Brighton. He had previously served on the North-East Frontier of India in the Aber campaign of 1912, receiving the frontier medal with a clasp.

The Sultan of Egypt has conferred the decoration of the Order of the Nile (Fourth Class) upon Captains T. W. Stallybrass and P. C. Field, R.A.M.C., in recognition of valuable services rendered.

Medical News.

THE Queen will open the recently established Unit of Obstetrics and Gynaecology at the Royal Free Hospital on Wednesday next, May 11th, at 3 p.m. It is the first unit in these subjects to be established in London. The director is Dr. Louise Mellroy, formerly senior assistant to the Muirhead professor of obstetrics and gynaecology in the University of Glasgow.

THE annual dinner of the Federation of Medical and Allied Societies will be held at the Café Royal on Thursday, May 26th. The chief guest will be Dr. Addison, in recognition of the services he has rendered, under circumstances of exceptional difficulty, as first Minister of Health. Sir Alfred Mond, Minister of Health, will be present, as also will members of the medical group in Parliament and other guests.

ON April 26th a presentation, which took the form of a suitcase and a cheque, was made by the staff of King Edward's Building of the General Post Office to Dr. S. B. Pennington as a mark of appreciation on his transfer from the E.C. district office, where he had been for seven years, to the Western district office.

THE Industrial Welfare Society proposes to hold a conference of medical men interested in industrial medicine on June 2nd. The purpose of the Society is to co-ordinate the individual efforts made by firms in different parts of the country to deal with the medical difficulties which stand in the way of industrial warfare. Medical men interested can obtain further information from the Director of the Society, Mr. Robert R. Hyde, 51, Palace Street, Westminster, S.W.1.

THE annual summer dinner of the Glasgow University Club, London, will be held in the Holborn Restaurant on Friday, May 27th, with Professor F. O. Bower, F.R.S., in the chair.

THE Cambridge and Paul Instrument Company, Ltd., has issued two new lists; the one of Cambridge microtomes, including the universal, rocking, and freezing microtomes. Particulars of the construction of the instruments are given. Copies can be obtained from the Company at 45, Grosvenor Place, London, S.W.1. The other catalogue describes the Cambridge recording clinical thermometers as devised for Sir G. Sims Woodhead and Dr. P. C. Varrier-Jones.

A COURSE of eight lectures is being given in the Physiological Laboratory at St. Bartholomew's Hospital, on Tuesdays, at 4.30 p.m. They are addressed to advanced students of the University of London and others interested in the subject. The course is recognized in connexion with the B.Sc. (Honours) degree in physiology. The first lecture was given by Professor W. D. Halliburton, on the cerebro-spinal fluid, on May 3rd; the lecture on May 10th will be by Professor M. S. Pembrey, on the secretion of milk; that on May 17th, by Mr. J. Barcroft, on alpinism; and that on May 24th, by Professor W. M. Bayliss, on the reaction of the blood. Other lecturers are Professors Leathes and Starling and Drs. H. H. Dale and Leonard Hill. Another course of eight advanced lectures in physiology is to be given by Professor H. E. Roaf at the London Hospital Medical College: these lectures will be given at 4.30 p.m., on May 12th and following Thursdays. The subject of the course is "Reception of Sensory Stimuli."

IN view of the passing of the Blind Persons Act, 1920, the Minister of Health has reconstituted the Advisory Committee on the Welfare of the Blind so as to afford representation to the local authorities under the Act and to voluntary agencies for the blind, and the following have been appointed members of the committee: Right Hon. G. H. Roberts, M.P., Chairman; Mr. P. M. Evans, L.L.D., Vice-Chairman; Mr. Alderman F. Askew, Mr. A. M. Bernard, Miss Winifred Bramhall, Sir Coles Child, Bt., Mr. H. Davey, Mr. James Graham, Mr. Connciller J. A. Hill, Sir William Hodgson, Mr. T. Holt, Mr. A. L. Lowe, C.B.E., Mr. G. F. Mowatt, Mr. H. J. Munro, Sir Arthur Pearson, Bt., G.B.E., Mrs. Wilton Phipps, Rev. P. S. G. Probert, M.A., Mr. R. Richardson, M.P., and Mr. W. H. Tate. The committee will advise the Minister on matters relating to the care and supervision of the blind, including any question that may be specially referred to them by the Minister. Mr. F. M. Chapman, of the Ministry of Health, will act as secretary.

THE house and library of the Royal Society of Medicine will be closed for Whitsun from Saturday, May 14th, until Tuesday, May 17th, both days inclusive.

THE summer session of the West London Post-Graduate Medical College, Hammersmith, commences on Monday next, May 9th.

A COURSE of instruction for qualified practitioners will be given at St. Bartholomew's Hospital during the summer vacation. It will begin on Monday, July 18th, and end on Saturday, July 30th. Particulars may be obtained from the Dean.

THE National Council for Combating Venereal Diseases will hold a meeting at the Caxton Hall, Westminster, on Tuesday next, May 10th, at 3.30 p.m., to hear the reports of the three Commissions which recently returned from the Far East, the West Indies, and the Mediterranean. The meeting will be open to the public. Representatives will be present from the various Government departments interested in home and colonial health and industrial administration, of mercantile marine associations and shipping firms, and of commercial houses trading with the places visited by the Commissions.

WE referred last week to an unfounded rumour that the baths at Harrogate were closing on account of the coal strike. We are now informed that a rumour, equally unfounded, has been in circulation with regard to other spas of the British Spa Federation, which include Bath, Buxton, Cheltenham, Droitwich, Llandrindod, Leamington, Woodhall, and New Zealand. The fuel supply at all these spas, as at Harrogate, is sufficient to enable them to carry on for some time.

A COURSE of post-graduate lectures in mental deficiency, supplemented by a course of clinical instruction, will be given at the University of London from May 23rd to June 4th. The course is based on the requirements of the syllabus for the University of London Diploma in Psychological Medicine. The fee for the course is 6 guineas. Full particulars can be obtained on application to Miss Evelyn Fox at the University of London, South Kensington, S.W.7.

OWING to the coal strike, the meeting of the Röntgen Society, announced in our last issue as about to be held on May 6th and 7th, has been postponed.

A MEDICAL journal, written in Spanish, entitled *Revista Médica de Hamburgo*, edited by Professors Braner and Noelt, has recently been founded for bringing Spain and Spanish America into closer relation with Germany.

DR. J. MITCHELL WATT, assistant in the department of materia medica in the University of Edinburgh, has been appointed to the chair of pharmacology at University College, Johannesburg.

Letters, Notes, and Answers.

As, owing to printing difficulties, the JOURNAL must be sent to press earlier than hitherto, it is essential that communications intended for the current issue should be received by the first post on Tuesday, and lengthy documents on Monday.

CORRESPONDENTS who wish notice to be taken of their communications should authenticate them with their names—of course not necessarily for publication.

AUTHORS desiring reprints of their articles published in the BRITISH MEDICAL JOURNAL are requested to communicate with the Office, 429, Strand, W.C.2, on receipt of proof.

IN order to avoid delay, it is particularly requested that ALL letters on the editorial business of the JOURNAL be addressed to the Editor at the Office of the JOURNAL.

THE postal address of the BRITISH MEDICAL ASSOCIATION and BRITISH MEDICAL JOURNAL is 429, Strand, London, W.C.2. The telegraphic addresses are:

1. EDITOR of the BRITISH MEDICAL JOURNAL, *Ailology*, Westrand, London; telephone, 2630, Gerrard.
2. FINANCIAL SECRETARY AND BUSINESS MANAGER (Advertisements, etc.), *Articulale*, Westrand, London; telephone, 2630, Gerrard.
3. MEDICAL SECRETARY, *Mediseera*, Westrand, London; telephone, 2630, Gerrard. The address of the Irish Office of the British Medical Association is 16, South Frederick Street, Dublin (telegrams: *Bacillus, Dublin*; telephone, 4737, Dublin), and of the Scottish Office, 6, Rutland Square, Edinburgh (telegrams: *Associate, Edinburgh*; telephone, 4361, Central).

QUERIES AND ANSWERS.

"ASPIRIN" would be glad if any members can inform him if they have come across any case presenting the "aspirin habit." His patient, a married lady 51 years of age, suffers from severe pains in the upper half of her chest and back; they recur every four or five hours, but are relieved by 5 to 10 grains of aspirin. She has been complaining for a year, and, as nothing definite can be made out, it has been suggested that taking aspirin may be simply a habit, especially as, on waking out of a sleep, she presents symptoms resembling those seen in a patient who gets hypodermic injections of morphine regularly.

DOUBTFUL SEX.

"NEMO" was asked recently to examine a supposed female child, aged 8 years. The attention of the school medical officer had been drawn to it by a nurse. He found the child to be a boy. The parents asked for the opinion of their own medical man, and "Nemo" confirmed the fact. The child is now attending another school as a boy.

A large number of cases of the kind have been recorded and the literature is very extensive. It was summarized by von Neugebauer, and a good epitome of his paper, "What value has the knowledge of pseudo-hermaphroditism for the practitioner?" will be found in the *Journal of Obstetrics and Gynaecology of the British Empire*, vol. 5, January-June, 1904, p. 379. Von Neugebauer collected 68 cases where marriage was concluded between people of the same sex. When there is great doubt it is best to bring up the subject as a boy, or if already taken for a female, to hold him to be a man, and dress and treat him accordingly. Hypospadias, with undescended testes, simulates the external female organs. In some cases it has been found impossible to determine the sex without excision of a genital gland and examination of its tissues under the microscope, and even then the opposite gland may be of the type of the opposite sex.

EXCESS PROFITS DUTY.

"W. F. R." has received a form requiring particulars of his profits since 1914. His practice is a mixed one, £900 of the total receipts of £2,400 being in respect of panel patients.

We imagine that the form must have been issued under some misapprehension, as the professional profits of medical men are undoubtedly exempt. "W. F. R." might write to the inspector of taxes, whose address is presumably given on page 1 of the form, pointing out that he claims exemption on the ground that his profits represent professional earnings, and asking for the request for particulars to be withdrawn.

INCOME TAX.

"G. L." has been resident in New Zealand, and during that time a private income arising in this country has been taxed at 6s. in the £. He inquires whether he has any redress.

No; at any rate not unless he was residing abroad for reasons of health, so far as the period to April 5th, 1920, is concerned. For the portion of the year subsequent to that date he might be able to claim as a British resident a rebate to the tax appropriate to his total income for that year, excluding his New Zealand earnings, which are not assessable to tax in this country.

"IRISH COMMAND" inquires what tax he is liable to pay?

	£	s.	d.
Army pay, £1,186 - £30	1,156	0	0
Deduct 1/10th, say	116	0	0
	1,040	0	0
Deduct personal allowance	225	0	0
Assessable income	815	0	0
Tax on £225 at 3s.	33	15	0
Tax on £590 at 6s.	177	0	0
Total tax due on army pay	210	15	0

In addition our correspondent is liable for tax at 6s. on his income from investments, unless and to the extent to which the tax is paid thereon at the source. The deduction for life assurance is £35 14s. 2d. at 4s. 6d.

LETTERS, NOTES, ETC.

THE GUILD OF BLIND GARDENERS.

MRS. ADOLPHUS DUNCOMBE (Buckingham Gate, S.W.1) sends a letter in which she asks help in making known to the medical profession an organization (The Guild of Blind Gardeners) which is being established to provide outdoor occupation for the blind, and to which we refer this week at page 680.

The matter (she writes) was brought before the Oxford Ophthalmological Congress in 1919, and met with very warm sympathy from the medical men present. Since then a great deal of work has been done, and we propose to inaugurate the Guild at a meeting to be held on May 26th, at 5.30, at the National Library for the Blind, 18, Tufton Street, Westminster. It is hoped in the near future to obtain a piece of land with sufficient accommodation to establish a training centre for the blind and partially blind. Among the speakers will be Mr. Godfrey Mowatt, Captain Pierson Webber and Fred Marriott, all blind, and the latter a practical gardener. My Committee are most anxious to interest medical men in the cause, as they, more than any others, can contribute to the success of the enterprise by putting their patients in

touch with our organization. I desire, in conclusion, to emphasize one point: Our aim is to help these unfortunate people to the obtaining of a useful occupation of their time and not merely to offer them charity.

CHRONIC RETENTION OF URINE ARISING FROM PROSTATIC DISORDER.

"AGED 61" writes: In the days of the iron-tired boneshaker I became a devotee to the cycle, and I attribute the earliest prostatic symptoms (in the late seventies) to riding a bicycle with much too long a stretch for my height: priapism was then my principal trouble. When the petrol motor appeared I was one of the first of our profession to indulge in its exciting experiences, now scarcely credible by the modern car user. When my birthdays reached 54 I began to notice (especially after a rough road had been ridden over) a sudden call to evacuate the bladder and then a "stammering" flow occasionally. I have now turned the three-score years, and this symptom only troubles me after a car run with a certain amount of jolting. I should be glad to hear if the measures taken by "Senectus" would be of use in relieving.

DR. V. P. ATKINSON (Bexhill-on-Sea) writes: If Dr. Herring has not read Dr. Griess's suggestion in the *Cincinnati Medical Review* of February, 1913, I think he will be pleased to hear what he says:

"Adrenaline used as a rectal suppository has a distinct value, whether on account of its local action before mentioned or on account of the action on involuntary muscular fibres generally, in that way helping the bladder in its expulsive efforts. All my patients note distinct benefits derived from their use, not only locally but generally, and complain when they are withdrawn."

EFFECT OF GUNSHOT WOUND ON SKULL.

"ARMY DOCTOR" writes: I can confirm "Coroner's" important observation, in your correspondence columns, as to the relative size of entrance and exit in bullet wounds. During the war I had many opportunities of observing self-inflicted wounds where one could be certain of the direction of the bullet, and I came to the conclusion that it is fairly common for the wound of entrance to be the larger. I do not remember ever having observed this when the bullet came from a distance, but it is very hard to be sure which way the bullet came in these cases. In spite of dogmatic statements in some books, it is not possible in certain cases to say at what distance from the victim the shot was fired, nor what direction it pursued. For instance, the fact of finding a modern high-velocity bullet lodged only an inch deep in a man's body would seem to preclude it having been fired at short range, yet I have seen this lodgement in a man who was hit by a machine gun fired inside the same barn in which he was standing. The bullet must, of course, have ricocheted in the interior of the building, but it was only slightly deformed. I have a great many times seen limbs traversed by a bullet fired at very short range which showed the small, neat perforations through bone and soft tissues popularly supposed to be caused only by missiles which have travelled far enough to have ceased vibrating. Singeing of the skin, as "Coroner" noted in his case, is frequently absent in those self-inflicted wounds where one would confidently expect its presence. These facts seem to have an important bearing on the teaching of medical jurisprudence.

ALKALINE DENTIFRICES.

"NESTOR" writes: Recently, in the JOURNAL, two of your correspondents have pointed out the harm caused by using an alkaline dentifrice for the teeth. As practically all the well known dentifrices are alkaline, and in view of the great increase in dental caries, it would be interesting to hear what dental surgeons have to say. It is curious that they should often recommend the mouth to be washed out at night with milk of magnesia, which leaves an alkaline deposit on the gums.

VACANCIES.

NOTIFICATIONS of offices vacant in universities, medical colleges, and of vacant resident and other appointments at hospitals, will be found at pages 30, 31, 34, 35, 36, and 37 of our advertisement columns, and advertisements as to partnerships, assistantships, and locum tenencies at pages 32 and 33.

SCALE OF CHARGES FOR ADVERTISEMENTS IN THE
BRITISH MEDICAL JOURNAL.

	£	s.	d.
Six lines and under	0	9	0
Each additional line	0	1	6
Whole single column (three columns to page)	7	10	0
Half single column	3	15	0
Half page	10	0	0
Whole page	20	0	0

An average line contains six words.

All remittances by Post Office Orders must be made payable to the British Medical Association at the General Post Office, London. No responsibility will be accepted for any such remittance not so safeguarded.

Advertisements should be delivered, addressed to the Manager, 429, Strand, London, not later than the first post on Tuesday morning preceding publication, and, if not paid for at the time, should be accompanied by a reference.

NOTE.—It is against the rules of the Post Office to receive *postea* retasted letters addressed either in initials or numbers.

An Address
ON
THE PREVENTION AND TREATMENT
OF PUERPERAL INFECTIONS.

BY
W. BLAIR BELL, B.S., M.D. LOND.,

GYNAECOLOGICAL AND OBSTETRICAL SURGEON TO THE ROYAL
INFIRMARY, AND LECTURER ON CLINICAL GYNAECOLOGY
IN THE UNIVERSITY OF LIVERPOOL.

No subject of so much importance to the happiness and equanimity of the general practitioner and to the well-being of the lying-in woman as the prevention and treatment of puerperal infections can ever fall or become commonplace so long as progress is delayed.

Of late various attempts have been made to focus attention on this point and that, but I venture to think that, as in all other debatable questions, the multitude of "essential points" indicates the uncertainty of our outlook and the doubtful value of some of our methods.

I have nothing new or striking to bring before you to-day; I shall endeavour, however, to look at the matter broadly and practically, and attempt to indicate in what way further progress may be made at the present time.

PROPHYLAXIS.

One of the most disturbing features of the mortality rate in regard to puerperal sepsis is the fact that the maternal mortality from infective conditions, which to-day should be almost negligible, is not decreasing as we have a right to expect. Indeed, in the Registrar-General's last annual report the mortality is shown to be greater than in any previous year for fourteen years. It is probable, moreover, that if we could exclude the epidemics that used to occur in maternity hospitals and in the practice of certain midwives, and which we now know were the result of easily preventable contagion, the present mortality rate would be found to be not greatly different from that obtaining in pre-antiseptic days. In other words, while epidemics have been banished the isolated case still runs an undue risk from causes that are preventable. Another important matter brought to light by recent statistics is that cases attended by doctors more often suffer with puerperal sepsis than those attended by nurses alone.

Is it possible in any way to account for this deplorable state of affairs? I think so, and in a few words. Cases in which there is no manual or instrumental interference are comparatively immune to puerperal sepsis—not completely of course, as I shall explain later, but almost so.

The importance of this is at once evident in regard to the cases attended by midwives. In all difficult labours a doctor is summoned to deal with the case. In such circumstances interference may often be necessary. This is a class of case with which I shall deal separately, because it must clearly be understood that even in such circumstances sepsis should not follow the operations performed.

Unnecessary Interference.

Before considering the general question of the prevention of sepsis when interference is necessary, I must say a word—and I think the time has come when someone should speak plainly—about unnecessary interference. In doing so I make all allowances for the fact that women of the present day, with their excessive indulgence in athletics and mental excitements, are laying up a store of difficulty for themselves should they be fortunate enough to bring forth child, and for the adverse conditions that exist amongst women workers in large industrial centres. We all know the athletic young woman with her resistant pelvic floor, and the woman "living on her nerves" who will not willingly or cannot tolerate a normal, let alone a tedious, inert labour. We are well acquainted with the stunted growth and small pelves of many women in factory districts. But allowing, I say, for all these embarrassments, which are the penalties of modern life, there is still a large number of cases in which interference is practised without scientific indication.

Twenty-five years ago "meddlesome midwifery," as it is called, was much less common than it is to-day, in spite of the fact that most of the procedures now practised by the

general practitioner, such as internal version and forceps delivery, were then in vogue. The student was taught in those days, as I hope he is to-day, that such operations are only to be practised in cases of real necessity, and that the necessity must be the mother's or the child's, and not that of other patients or of other calls.

Most practitioners of to-day, in contradistinction to those of the past, are surprisingly expert with the forceps; but I do not think the good done with these instruments adequately atones for the damage that too often follows the indiscriminate use of them. Familiarity is apt to breed contempt in all of us, and we are apt to find a too frequent use for that with which we are proficient. I realize, however, that in an appreciable number of cases the forceps are employed from what I may call humanitarian motives—to save the mother pain or to appease an anxious husband. That is moral cowardice to which we are all prone. But there are, I am afraid, many who make a practice of terminating with forceps nearly every labour at which they are present—more often than not with forceps taken from a "midwifery bag" which is far from clean and very imperfectly sterilized.

If the maternal mortality and morbidity rate is to be diminished, to say nothing of the number of operations for prolapse and other lesions due to hurried parturition, this practice must stop. It must be held to be a discreditable thing to terminate labour with forceps to placate the patient or to save the time of the practitioner, however skilful he may be.

Again, it should be a point of honour with all those who practise midwifery that no parturient woman shall be examined unless the examiner wear a sterilized glove. Even then the examination is best conducted per rectum, as Eardley Holland has suggested.

While I am convinced that unnecessary interference—accompanied, of course, by imperfect asepsis—is largely to blame for the present mortality rate in regard to puerperal infections, I do not wish for a moment to infer that there are not other considerations of great importance. It is, for instance, necessary for the practitioner to be fully acquainted with all the circumstances favouring infection in the parturient woman if he is successfully and safely to accomplish obstetrical operations in cases of necessity; and in this matter sound judgement as to the correct procedure may be a deciding factor in the result.

Natural Defences against Infection.

Normally there are two natural defensive arrangements for the safety of the mother. Towards the end of pregnancy there is a moderate leucocytosis in the circulating blood, and the vagina maintains its acid—lactic acid—secretion. But in circumstances not yet fully understood there may be a little or no increase in the number of leucocytes in the blood, and the acidity of the vagina may be considerably reduced or completely neutralized. The leucocytosis is a second line of defence, while the normal acid secretion of the vagina is the first. It goes without saying that the resistance of a healthy young woman is much greater than one weakened by malnutrition or disease.

The Points of Entry.

After normal parturition there is a large raw surface, the placental site. This is favourably placed for aseptic healing if no organism be present; but in the presence of infection it is most unfavourably situated in a cavity with only a potential outlet, and every blood clot closing a venous sinus is for bacteria an excellent nidus at body temperature.

While the placental site is nearly always the place of entry of the organisms in the more serious generalized puerperal infections, any laceration of the cervix, vagina, or perineum may form a point of entrance. It behoves us, therefore, to ensure healing by first intention in all lacerations, however caused. Neglect of this precaution often leads to the wound becoming septic, if the obstetrical operations have not been aseptically conducted or the environment of the patient be bad. It is interesting to note how well a sutured wound in a vascular area will heal, even in the presence of bacteria. An attempt is usually made by the practitioner to repair a lacerated perineum, and a certain amount of healing generally takes place, although the ultimate anatomical result is not always good. I always teach my students to insert sutures

* Delivered before the North Staffordshire Medical Society on April 21st, 1921.

accurately before laceration of the perineum occurs, if this appear to be inevitable. Accounts of how this should be done have been published, so I shall not discuss the procedure further. The cervix and vagina, however, usually escape attention at the time of labour, probably owing to the greater difficulty of discovering lesions in these situations.

Types of Infection.

We have heard a good deal lately about the question of autoinfection, by which means the patient becomes infected, either at the placental site or in some laceration produced in the birth-canal, with bacteria present at the time of delivery.

Pneumococcal infection, although rare, is not unknown. I have seen infection with this organism of the placental site, with death of the patient, follow an apparently normal labour during which not even a vaginal examination had been made by the doctor or the nurse in charge. Likewise, the gonococcus, which is too frequently present in the genital passages, and is more or less indifferent to the acid secretion of the vagina, may cause infective lesions; but, as a rule, gonorrhoeal infections remain localized.

With regard to streptococcal autoinfection there has been much controversy. It is now generally agreed that even in those cases in which streptococci have been isolated from the vaginal secretions prior to parturition, puerperal infection has by no means necessarily occurred. The presence or absence of these organisms has been shown to be closely related to the cleanliness of the patient; and it is probable that sexual intercourse at the end of pregnancy accounts in many cases for the presence of streptococci in the vagina. This is a practice against which it is our duty always to warn our patients; yet how rarely offered is the advice!

With these exceptions, and conceivably with such remote possibilities as infections by *Bacillus typhosus* and *Bacillus diphtheriac*, it is wise to regard autoinfection with suspicion. I believe, as I have already indicated, that death from puerperal infection is extremely rare after a normal labour in which there has been neither vaginal examination nor operative interference. In a vast proportion of all cases the bacteria are carried to the site of infection by the accoucheur or the nurse. It is therefore neither right nor courageous for the obstetrician to shelter under the possibility of autoinfection and lack of resistance on the part of the patient until such conditions have been proved beyond doubt by the scientific means at our disposal. Moreover, it must be remembered that these matters can be investigated before labour commences.

The most serious effects are produced by the streptococcus, which, according to my own experience in many cases investigated, is practically always present in generalized infections, even though other organisms be also found. *Bacillus coli communis*, *Staphylococcus aureus*, and *Bacillus aerogenes capsulatus* may occur; the first mentioned with considerable frequency. All these organisms are constant denizens of the bowel and the vulva.

Bonney, as many of you will know, thinks that the situation of the anus is a serious blemish in the foresight of—Evolution, shall I say? I do not agree with him; I think it is a danger spot, but it is so evident that it becomes a danger signal. The skin surface of the vulva is no less dangerous; indeed, a piece of unpurified vulval skin and hair placed in the uterus would probably be far more deadly than a spoonful of faeces. Moreover, faeces look infective, whereas the vulva does not, and the latter, therefore, constitutes a danger too often unsuspected—a danger so great that many of the investigations of skilled bacteriologists concerning the flora of the vagina have been vitiated. I fancy that Evolution has made us fairly resistant to the organisms of the rectum by virtue of our cloacal ancestors. I have never seen it suggested that the gradual disappearance of *Ornithorhynchus* is due to post-ovoviviparitional infection. Further—and this is important—I do not think serious puerperal infection forms a regular part of the history of cases in the human subject in which there has been complete laceration of the perineum into the rectum. Such an injury is no more prone to serious infection than is that in which the laceration is partial.

However that may be, it is quite certain that infections with the organisms of the bowel do occur; nevertheless I do not think we should blame Evolution, which has

made no secret of the matter, but rather the careless attendant who contaminates his hands, in spite of the danger being obvious.

With such perils awaiting the incautious, is it any wonder that the chief element of safety is a negative one—non-interference? By non-interference the two chief factors leading to puerperal infection may almost certainly be avoided: organisms are not carried into the birth-canal, and lacerations, especially of the vagina and cervix, through which bacteria may gain entry, are less liable to occur.

Asepsis in Obstetrical Operations.

When interference becomes necessary, a surgical operation is performed, as Victor Bonney has so wisely emphasized. Every practitioner should, therefore, carefully foster in himself what I may call conscientiousness in regard to asepsis. No makeshift must satisfy him. While normal labour is physiological and there is no justification for interference, abnormal labour, on the other hand, is so serious—the possibilities of infection are so great—that nothing must be left to chance.

In the first place, every care must be taken to preserve the acid secretion of the vagina; consequently preliminary douches should never be employed. In the second place, every possible precaution must be taken by the practitioner, not only in regard to the wearing of sterile rubber gloves and gown and the boiling of all instruments, but also in regard to the always infected areas surrounding the orifice of the vagina. The escape of faeces is indicative of imperfect preparation on the part of the midwife, who should make sure that the big bowel is empty long before interference becomes necessary. In any case this is a small difficulty with which it is always possible to deal effectually before anything is done. The vulva must be shaved and the skin purified by means of one of the aniline dye or other preparations used for the sterilization of skin surfaces; and this purifying process must include the anal orifice, which is afterwards suitably protected before intervention is practised.

All this ritual is absolutely necessary; but is it possible for the unpaid, overworked practitioner? It will be said, I know, that thousands of forceps deliveries are effected daily without mishaps; yet 1.7 maternal deaths occur from registered sepsis—excluding phlegmasia and other conditions due to infection—in every thousand deliveries of live children.* How many mothers survive infection, perhaps permanently damaged, is, of course, unknown. This is a matter worthy of deep and serious thought. It is worth while, indeed, to consider whether interference should ever be practised in really unsuitable surroundings.

The time will come, I hope, when the Nation, and through the Nation the Government, will realize that parturition, especially when interference is necessary, cannot be conducted in rooms in which the accoucheur has to tuck his trousers into his socks—a tent in a public park would be infinitely better—and that, when interference is necessary, the practitioner must be awarded fees commensurate with the responsibility undertaken, the skill employed, and the cost of proper aseptic equipment, or equivalencies must be provided.

THE TREATMENT OF PUERPERAL INFECTIONS.

As I have already stated, probably a large majority of all cases of puerperal infection escape death, which still figures with such alarming frequency in the statistics of the Registrar-General, but certainly with deceptive relativity in regard to puerperal infections generally. This makes it obvious that the mortality rate would be much higher if it were unrelieved, not only by antiseptics, but also by the improved methods of treatment. It follows, therefore, that many opportunities are offered for the treatment of these cases, but I regret to say that, generally speaking, we have not made the best use of our opportunities, for cases of puerperal infection are unwelcome in maternity and surgical departments. In most large cities the patients find their way into the fever hospitals, where expert service is rarely available.

Infections of the Placental Site.

Most of us have come to regard sapraemia as a bacteriological refinement that should find no place as a term of

* Registrar-General's Report for 1919.

endeavourment in the disturbed conscience of the practitioner. The absorption of toxins produced by putrefactive organisms is, of course, not uncommon, and in such circumstances there is usually a foul discharge; but until streptococci and other pyogenic bacteria have been proved to be absent, as is rarely possible, they must be assumed to be present.

Infection of the placental site is always accompanied by pyrexia, an increased pulse-rate, and the other well-known signs of fever.

There is no commonly accepted morbidity figure, but a safe rule in regard to the necessity for active measures may be said to consist of the recognition of a rise of temperature over 101° F. on the second evening after the confinement. This should be a definite indication for intervention.

The uterine cavity should be explored with the gloved finger in order that any placenta which may have been retained may be removed digitally. In my opinion curettement, except with the finger, should never be employed. Some of the worst cases of puerperal septicaemia that I have seen have followed the use of a sharp curette. The uterus must subsequently be irrigated with a suitable antiseptic solution. I use Milton fluid, which is a powerful and stable hypochlorous acid preparation. It is advisable to use a strong solution of this fluid (1 in 10), which is hypertonic, for the first irrigation. Afterwards a solution of 1 in 30 will be found better, as the stronger solution is apt to be slightly irritating to the skin of the vulva.

A majority of all cases rapidly improve, some after one irrigation. This treatment may therefore be considered abortive in its action, and it is very efficacious in this respect. In the days past the solutions used were either poisonous to the patient or too weak antiseptically to be of much value, but even in these circumstances irrigation was found very advantageous—no doubt because the uterine cavity was cleansed mechanically.

If such treatment be delayed, or if in spite of such treatment the infective process continue, it is advisable, when thirty-six or forty-eight hours have passed without considerable improvement, for the practitioner to carry out irrigation more effectually by inserting into the uterus a double-tube—a large pattern similar to that which I use in the vagina after colporrhaphies—which may be fixed to the cervix with a stitch. With this tube in position the uterus can be irrigated very frequently without much discomfort to the patient.

When the lesion has become more than a superficial endometritis, serious surgical operations may be required. If there be localized abscesses in the uterine wall, the tubes or the ovaries, these structures must be removed, often at a fateful moment of selection.

Surgical interference is also, in my opinion—which, however, is not yet generally shared—the correct mode of procedure in cases of generalized septicaemia and pyaemia, if the condition of the patient and stage of the disease warrant operative intervention.

In general septicaemia without thrombosis of the pelvic veins the prognosis is extremely grave and the patient rarely recovers. Nevertheless, I believe that prompt ligation of the ovarian veins, which are easily accessible, and the internal iliac veins, cuts off to a considerable extent the general invasion of the blood. When the veins are definitely thrombosed and the patient has shown signs of pyaemia with a hectic temperature and corresponding rigors, the abdomen should be opened and the involved veins ligated and in certain circumstances excised.

I have practised this operation eight times in desperate cases with a fatal issue in two, in one of which the infection was with the pneumococcus. In two of the cases that recovered there had been aseptic emboli in the pulmonary vessels.

I have seen autogenous vaccines and polyvalent anti-streptococcal serum apparently do good in cases of acute general puerperal infections, but I think that while, whenever possible, they should be employed, the wise practitioner will not rely entirely on their efficacy in the present state of our knowledge. I have considerable faith in the intramuscular administration of 0.5 c.c.m. of infundibulin (pituitary extract) extract every night and morning to maintain a proper blood pressure. I have, too, had one very happy experience in a case of streptococcal septicaemia of appendicular origin, which has indicated to me that

blood transfusion may be of temporary assistance to the surgeon in fighting a desperate condition.

Infections of Lacerations.

Cellulitis usually follows the infection of lacerations of the cervix and vagina. The condition may be acute or somewhat chronic in its course; it may commence acutely and become chronic. Patients may be invalided for many months, and ultimately may be permanently affected by the lesions produced. Only occasionally does pelvic cellulitis prove fatal, and then because there has been failure to evacuate pus at the proper time. Cellulitis is easily discovered on examination of the patient, for the cellular tissue of the pelvis, especially of the broad ligaments, is involved, exudation follows and the uterus becomes fixed.

The treatment adopted in the early stages should consist of the sterilization, as far as possible, of the infected wounds, and the use of hot douches. If suppuration occur, drainage of the abscess cavity must be established.

Occasionally, however, septicaemia follows an acute streptococcal infection of a laceration. In these circumstances the treatment is confined to the purification of the wound and the employment of vaccines and serums, infundibular extract, saline infusions, and possibly of blood transfusion.

SUMMARY AND CONCLUSIONS.

1. There must be an honest recognition by all who attend childbirth that puerperal infection is almost always avoidable, and that the appearance of it in any case that has been examined, or in which interference has been practised, is a serious reflection on the accoucheur or accoucheuse. If the whole profession would combine in an attempt to reduce the present incriminating figures a great change would be noticeable, not only in the statistics presented by the Registrar-General, but also in the health of the female population which is perpetuating our race.

2. The remedy does not lie in better teaching, so far as practitioners are concerned, but in obedience to the dictates of conscience. No man can plead ignorance of asepsis and antisepsis to-day. The trouble is that imperfect asepsis is practised as a sop to conscience instead of complete asepsis as a real scientific safeguard.

3. Examination per rectum with the gloved finger should be practised in the case of the parturient woman in preference to vaginal examination. Forceps delivery is far too common. Most women deliver themselves safely if left alone. Forceps delivery, when necessary, is a surgical operation, and should not be conducted in insanitary surroundings.

4. All lacerations, not only those of the perineum, must be efficiently sutured.

5. Care must be taken to maintain the natural defences of the patient.

With regard to the treatment of puerperal infections the chief conclusions are:

1. The evacuation of large pieces of placenta and efficient antiseptic irrigation of the uterus should be practised in the early stages of infection of the placental site. All infected lacerations should be purified.

2. The employment of autogenous vaccines and polyvalent serums is often useful in cases of generalized infection.

3. Major operations must be performed, especially ligation of the veins in puerperal thrombo-phlebitis, without hesitation and in good time when indicated.

As to the more general considerations, the principal conclusions are:

1. Much research is required to define more accurately and fully the general and local defences against infection in the normal parturient woman, and the causes that lead to their diminution.

2. The immediate reception and accommodation of all cases of puerperal infection into a special ward connected with gynaecological and obstetrical clinics, where each can be adequately investigated and efficiently treated, should be possible.

3. Aseptic midwifery is prohibitively costly to the general practitioner in comparison with the fees obtaining

in the poorer parts. In every district a *dépôt* should be established by the local authority from which the general practitioner could obtain a sterile outfit free of cost.

4. The present statistics are an urgent indication that better organization is required. In various centres, especially in industrial districts, large maternity and gynaecological clinics should be instituted. When possible they should be attached to the teaching schools. These clinics should form base hospitals for wide areas, in the outlying parts of which a few beds should be set aside in existing cottage hospitals, or, failing these, small field hospitals should be established for the reception of maternity cases. In these field hospitals general practitioners would have an opportunity of working under the best conditions when interference was necessary. In cases of special difficulty skilled assistance could be summoned from the base hospital, if the patient were too ill to be moved. Whenever difficulty was anticipated the patient could be sent before the commencement of labour to the base hospital for delivery.

Remarks

ON

THE USE OF PEPTONE IN ASTHMA AND ITS CONGENERS.

BY

A. G. AULD, M.D., M.R.C.P., D.P.H. OXON.,

RESEARCHER AT UNIVERSITY COLLEGE, LONDON.

THESE remarks have been largely prompted by the numerous inquiries and requests for further information received since my last paper.¹ Any new treatment necessitates a long period of probation; it must be tested and retested in a large number of cases, and the results scrutinized in the light of any criticisms which legitimately may be raised. It is satisfactory, meanwhile, to be able to state that the reports from many sources, both home and foreign, are such as to justify the general conclusions previously recorded. The treatment has been applied not only to asthma, but also to such of its congeners as hay fever, associated skin affections, angio-neurotic oedema, cyclic vomiting, periodic diarrhoea, and the migraine-epilepsy syndrome; in short, to such conditions as exhibit an anaphylactic character or sensitization.

The Scientific Basis.

The discussion in my previous papers as to the scientific grounds of the treatment had, as its pivot, the identical characters of anaphylaxis and peptone poisoning or shock. But, notwithstanding the arguments employed and the clinical results, it was difficult for many, and especially for those practically acquainted with experimental anaphylaxis, to believe that a substance (peptone) which had lost its specificity, and could functionate no longer as an antigen in the strict sense, was nevertheless capable in small doses of counteracting the effects of a specific antigen. I took the view that the immunizing action of the peptone was directed, not against the antigen itself, but against the antigen-antibody product. This product, by its interaction with the cell-protoplasm, is the cause of the anaphylactic shock, which is identical with the shock produced by the interaction of peptone and the cell-protoplasm. It is usually believed that a substance of great potency, such as histamine, results from this reaction. That there is also a violent dislocation of the colloidal equilibrium of the blood and cells by a coalescence or aggregation of particles is likely, and is even regarded by some as a sufficient explanation of the phenomena. As bearing on this, mention may be made of some clinical experiments (not yet completed) which I made with lecithin. In the course of these I observed that a bile salt solution of the purest lecithin obtainable, intravenously administered, seemed to exert a more or less inhibitory effect on the anaphylactic reaction. As both bile salt and lecithin reduce the surface tension, their action would be directed against the coalescence of colloidal particles by stabilizing the electric double layer. Possibly it is in this direction that the inhibiting action of narcotics is to be sought.

¹ Most commercial lecithins are grossly contaminated, and give rise to toxic symptoms.

It appeared to me that the case for the clinical use of peptone might be well served by animal experiments, so some little time ago I put the matter before Dr. H. H. Dale, and urged him to carry out some experiments with small doses of peptone in relation to anaphylactic shock in sensitized animals. This he kindly agreed to do, and lately I received from him a preliminary report in which he says, "The results are definite enough. A dose of peptone not itself large enough to produce any pronounced reaction, will weaken the response of a sensitized guinea-pig to the sensitizing antigen, so that after such a dose it is possible to desensitize without at any time producing any pronounced reaction. This I think ought to be valuable." . . . "The specific desensitization would appear, in part at least, to be due to the detachment of antibody from the cells."

As Dr. Dale intends to have the matter more fully investigated, it is sufficient to remark that as it has now been proved experimentally that peptone in small doses can inhibit the anaphylactic shock, its clinical use in conditions of sensitization has been placed on a solid foundation. Previous experiments with peptone in this connexion were made with massive doses and the results were conflicting. But one usually finds in experimental work that the effects of small doses are not sufficiently studied.

Now this active immunity or desensitization produced by peptone is a totally different process from immunization as ordinarily understood and practised. The immunity produced by a bacterial vaccine or a native protein is associated with the production of antibodies which are stereochemically fitted to the particular antigen and to no other, although there is a certain amount of overlapping in nearly related antigens. These antibodies when circulating in the blood dispose of the antigen, but if they are attached to the tissue cells and the antigen gains access to them, shock results. Peptone forms no such antibodies. When the protein molecule is reduced to proteoses and peptones, its specific architecture is practically obliterated, so that the immunizing action of peptone is independent of the nature or configuration of the antigen. It is a desensitizer in the general sense, though possibly more effective against some antigens than others. Dale, as is seen, thinks that this action on the part of peptone is, partly at least, such as to lead to detachment of antibodies from the cells. They would thus become free in the blood, and destroy or render innocuous the antigen.

Nature and Effects of Sensitization.

It was recognized by our forefathers that heredity and a family relationship were frequently encountered in those disorders which we may now reasonably regard as expressions of sensitization. Recent observations (R. H. Cooke and Van der Veer,² Freeman,³ Buchanan,⁴ etc.) have more fully set out these relationships, in which some have found strong evidence of the operation of the Mendelian law. If sensitization, potentially considered, implies the segregation of determinants in the germ plasm and is transmitted as a dominant factor, much that was obscure becomes luminous. The transmission may not be the particular sensitization but an abnormal susceptibility to form antibodies to foreign proteins, a "vice of nutrition." As regards the nervous system, Buchanan's studies lead him to conclude that the migraine factor is the transmitter, as 75 per cent. of essential epileptics have a migrainous strain. Possibly the rare disease "family periodic paralysis" is also an example of sensitization in which the antigen attacks the mechanism of inhibition.

The earlier the symptoms appear the stronger as a rule the inheritance, which may be double. On the other hand, failure to elicit a positive history is by no means conclusive, as no adequate study of the heterozygotes may have been made in relation to recessive unit characters. The clinical symptoms depend on the locality of the sensitized cells, and it is also likely that the offending protein has a predilection for certain parts or cells. Very often the whole body seems to take a sympathetic part in relation to the sensitization of a particular structure, while in other cases the sensitization seems practically confined to a limited area. In this relationship, cutaneous tests, though in some cases definite enough, play tricks with us, and their significance is very far from being understood. This is forcibly brought out in the writings of Schloss, Smith, Longcope, Highman, Wells, and others. In some cases

the reactions disappear for a time, to reappear sooner or later; in others they exhibit constancy, as in hay fever. Another pitfall is encountered in the circumstance that after the disorder has subsided, either spontaneously or as a result of treatment, the dermal reaction often persists. This is notoriously the case in hay fever, so that the local reaction is not a guide to treatment. Again, dermal reactions are given to non-protein substances, such as amino-acids and the normal urine of animals, and even to inorganic substances. In the latter case, however, the agent may interact in such a manner with the protein molecule as to change it to what is practically a foreign protein. In regard to the proteus used as foods curious anomalies occur. These reactions are mostly found in children, and may be associated with others to animal emanations, etc. (multisensitization). According to the authorities quoted above, cases occur "in which it is impossible to prove that the substances to which the patient reacted were responsible for the symptoms." Rackemann⁶ in 127 tested cases obtained positive reactions (one or more) in 74, but only in 40 of these were the tests compatible with the patients' history. It has also been shown by Longcope and others that a fair number of individuals who have never had any clinical manifestation of sensitization, will give positive reactions to foods, the limit apparently having been reached when an orthodox Jew was positive to pork, oysters and sturgeon,⁶ so that "cutaneous allergy and systemic anaphylaxis do not necessarily predicate each other," as "the contradictions are such as to defy positive conclusions." It is just possible, therefore, that the skin may be the only sensitive organ in some cases. One may say that the cutaneous reaction has a very real value, but its limitations and vagaries must be recognized.

The conception of the inherent susceptibility or molecular disposition on the part of certain cells to sensitization as a form of potential energy which is easily made kinetic by influences or agents otherwise harmless or almost so, has a clarifying effect on the mutual relationships of sensitization and the offending protein; while it also rescues from the region of mystery the association of asthma with such factors as locality, barometric pressure, nerve shocks, etc., as all these have a disturbing effect on the protein metabolism. As regards the first of these considerations, take for instance the case of eczema. This is often regarded as an anaphylactic condition and dermal reactions sought for. If such be found, it merely proves that the skin is sensitive to certain substances, as the irritant which gives rise to the eczema may be one which is incapable of producing a positive dermal reaction. An experiment by Auer⁷ is apropos. He painted the ears of sensitized and of non-sensitized rabbits with xylol. The ears of the latter exhibited an inflammatory oedema which passed off in forty-eight hours. The ears of the sensitized animals showed in one or two days small haemorrhages, blisters, and subsequent crusts. Here the effect of sensitization was greatly to intensify the symptoms, so that a sensitized structure apparently reacted vigorously to a substance—xylol—which is not itself capable of sensitizing. The explanation is to be found in the inflammatory stasis, producing a local concentration of circulating antigen and its attachment to the tissue antibody. In like manner as regards asthma, the underlying predisposition or sensitive potential of the bronchial muscle may be activated by agents, chemical or bacterial, operating either locally or at a distance, which cause the entry into the circulation, and subsequent local accumulation of substances which are antigenic in relation to the bronchi. Possibly also it is by a similar formation or mobilization of antigen that attacks may sometimes be produced by the inhalation of cleavage products of protein (peptone) and by metallic fumes. It is therefore the more evident that the sensitized or potentially sensitized structure can never be wholly protected from attack, and the only possibility of relief or cure consists in a desensitization which must be more or less lasting.

Clinical Examination.

The investigation of the family and personal history will furnish data which materially assist the prognosis and also the treatment. The main considerations are the degree of inheritance, the age of the patient, the age at onset, the frequency and severity of the attacks, and the associated

diseases or defects. In asthma more or less resistance to treatment is associated with a practically continuous dyspnoea, emphysema, bronchitis, cyanosis, or anoxaemia from whatever cause, anaemia and various toxaeemias. The respiratory excursion should not be under one and a half inches. The pulmonary bases may be congested. Cyanosis or anoxaemia usually arise from obstructive conditions, pulmonary or circulatory. It is interesting to note in regard to these that Wooldridge found a reversed action of peptone on the coagulation of blood through which carbon dioxide had been passed. Also Loewenhardt⁸ and his associates record some curious results with sodium iodosobenzoate, a substance which induces powerful physiological oxidations. They affirm that its use intravenously will diminish or nearly abolish the cutaneous reaction in serum-sensitized rabbits. This suggests that the more oxygenated the blood the easier the desensitization. Toxic substances in circulation also appropriate a quantity of oxygen and otherwise dislocate the protein metabolism, so that blood and urine examinations for nitrogen estimations may be necessary. The stomach may be dilated; digestive disturbances are frequent and cases occur which seem undoubtedly sensitizations of the gastric and intestinal mucosae. The liver may be enlarged or tender, or the spleen may be enlarged. In women some connexion of the attacks with menstruation or its irregularities may be found. The various mucous passages or the teeth may harbour foci of infection requiring eradication. A careful survey should be made bearing on endocrine function, and small daily doses of thyroid or pituitary prescribed as indicated. In a few unsuspected cases I have found hypothyroidism the chief accessory factor.

The patient should be interrogated regarding the possible association of the symptoms with any particular substance, animal or vegetable, or other influence. Skin tests may be made to pollen, horse dandruff, or any suspected animal's epidermal structures. Reactions to killed bacteria are admittedly valueless. In children positive reactions are sometimes obtained to foods, usually vegetable, but rarely in adults, or at least those over 35. Egg, wheat (or oats), potato, and certain green vegetables are the chief offenders, but even these are found in only a very small percentage of the cases. So far as the peptone treatment is concerned, the performance of the numerous American tests is practically an academic function.⁹ Ordinarily it is sufficient to rub the food in its natural state into a bloodless scratch or puncture. Solid substances may be crushed and rubbed in with a little decinormal sodium hydroxide, which facilitates both solution and absorption. Similarly with horse combings or feathers. A control with the soda solution is made, and in each case a wheal results in a few minutes. A reaction cannot be regarded as definitely positive unless the wheal is half as large again as the control, and over 0.5 cm. in diameter. The dermal response to the peptone (used after the same manner) should also be made. A marked reaction is the signal for smaller doses in treatment.

Treatment.

The patient should be placed in the most favourable conditions, even as regards locality, if practicable. The better the patient's health and the greater the freedom from asthma during the immunization, the better the ultimate result and the capacity of withstanding prejudicial surroundings. Unless there be a well-marked intolerance or idiosyncrasy to any particular food, it is unnecessary to cut out of the patient's dietary articles which give moderate or slight skin reactions, as the peptone rapidly alleviates the symptoms. Indeed, it is much more difficult to desensitize to the cast wind than to foods. If a definite infection exists which produces (directly or indirectly) protein products exciting the attacks, it may be capable of removal by a suitable vaccine. Even then a general desensitization of the bronchi is not effected, as the vaccine desensitizes to the related bacteria only. The general desensitization produced by peptone, on the other hand, may be so effective that in cases where the asthma was invariably excited by catarrh of the bronchi no longer give the least response to the infection. The same result may be obtained in relation to infections in remote situations contributing to the production of the attacks.

⁹ A warning against fetishism in relation to this has just been given by the *Journal of the American Medical Association* (April 9th).

The groups into which the cases of asthma fall and the corresponding results of treatment were indicated in my last paper. The formula published in the *BRITISH MEDICAL JOURNAL* (July 20th, 1918) has stood the test of time, and by means of it the asthma types in Group I, and many cases of migraine and epilepsy, have yielded, sometimes very quickly. In asthma the relief may last for years, especially in children, and possibly for a lifetime. The formula has also been successfully applied in cases of hay fever, in skin affections associated with asthma, and cyclic gastro-intestinal attacks. In the latter disorder, peptone taken by mouth may give relief, possibly in virtue of a direct action on the sensitized cells. The peptones recommended were Armour's No. 2 (5 per cent.), and Witte's (2 per cent.). The Witte peptone, however, contains too much primary proteose in relation to secondary (according to Dr. R. H. Plimmer, roughly as 1 to 2). The proportion in the Armour peptone is (same authority) as 1 to 7. Therefore, either a 5 per cent. solution of the No. 2 may be used, or else a 5 per cent. solution of a mixture which contains 3 parts of Witte's peptone and 5 parts of a peptone practically devoid of primary proteose, as may be physiologically suitable. The No. 2 peptone has been found very satisfactory for ordinary use, and can be used intramuscularly without causing irritation, but it varies in acidity and solubility. "Peptone siccum" (Armour) is a finer product, but requires the addition of some primary proteose (3 parts to 1 Witte's). When freshly prepared, the solutions are rather more active. To prepare the solution proceed as follows:

Dissolve the peptone or the mixed peptones as far as possible by agitation in hot (56° C.) normal saline. Take the reaction to litmus (usually acid), and add very carefully normal or semi-normal sodium hydrate or carbonate, until the solution is faintly yet distinctly alkaline to litmus. The peptone will now be dissolved, except for some insoluble residue. Make up to volume with normal saline, and place in a water bath at 56° C. for half an hour. Filter while hot through ordinary filter paper, and add to the filtrate 0.5 per cent. phenol. If bottled, sealed rubber caps or well-fitting glass stoppers or rubber stoppers should be used. Wait for three days and then smear a loopful of the fluid over an agar slant and incubate for sixteen hours at 37° C. If the result is negative the peptone may be passed for use.

The solution, as above prepared, may be used in a 5 per cent. strength intravenously (or in a 7.5 per cent. strength intramuscularly) in the following dosage: The initial dose is 0.3 c.cm. (5m), and is increased every third or fourth day (twice weekly) by 0.2 c.cm. until 1.3 c.cm. (20m) is reached at the sixth injection. Continue at this dosage for six more injections. Give intravenously as a rule in adults, very slowly delivered.

Now this formula was adjusted to the average case. It is impossible to tell what modifications may be required until the case is under treatment and the history and symptoms are before one. But in any event there are some guiding principles common to all. The aim is to avoid reaction at first while getting close to the reaction point or threshold. The best and most enduring results are obtained in cases which get well from non-reactive doses. The rule, therefore, should be observed of recording the temperature 5 to 6 hours after each injection. Should there be a rise of over 1° F., the subsequent dose is not to be increased. On the other hand, the dosage may be too small, and if after eight injections no satisfactory improvement is made, and if there has been no rise of temperature, a test dose should be given—that is, one which we know will give a mild or moderate reaction (100° to 101° F.). This mild reaction does no harm at this stage, and in some cases, especially if tedious, gentle reactions are beneficial towards the end of the treatment. A reliable indication of the correct dosage is frequently an improvement in the general health and in a sense of well-being. The adjustment of the dose to the particular case is very essential, and in view of the variable character of some kinds of peptone on the market I always have them physiologically tested before use.

Reference now may briefly be made to the resistant cases. They are sometimes very puzzling, as they may present no obvious differences to some of those which yield, but there is usually a stronger inheritance. Then there are the cases which are handicapped by deterrent or incurable accompaniments. Unless the asthma is practically continuous or there is much bronchitis and emphysema, or some permanent constitutional breakdown from infection or senility, much can be accomplished by various

modifications in the treatment, including the peptone itself, the dosage, the reaction, and the duration. Each case is largely a law unto itself, and though it is impossible to particularize, a few leading indications may be set out. As regards the peptone itself, that in use has been made exclusively from meat or blood fibrin. Lately I have been using, in addition, proteose-peptones* made from phospho-proteins, albumins, and certain vegetable seeds. In all of them the amino-acids possessing the benzene nucleus were well represented. As our food is largely vegetable, and as sensitization is more in evidence in this relation, it seemed feasible that vegetable peptone might find some new point of attack or open valence. For, although there is no essential difference between animal and vegetable proteins, yet they differ widely in structure and in their reactions to heat and reagents, and no doubt the earlier products of their hydrolysis also present well-marked differences. This peptone I have employed either alone or in combination with one of the animal kinds—compound peptone. These new peptones give promise of most valuable assistance.

In regard to the dosage, in some cases the sensitiveness to peptone is such that even small doses seem to augment the symptoms. The addition of a few drops of Lugol's iodine will obviate this, as the iodine enters into chemical union with a certain fraction of the peptone molecule, without otherwise affecting its value. It may be omitted as toleration becomes established. When, on the other hand, the peptone is well borne, it may be pushed, and though attacks occur for a time, the ultimate result may be quite satisfactory. It may be necessary to continue treatment for nearly three months, and during the latter period the peptone may be given at rather longer intervals and so as to produce some reaction, which, however, should always be mild. A strong reaction upsets the immunization by rendering subsequent smaller doses ineffective, at least for a considerable time. These are a few amongst other considerations which have to be borne in mind.

REFERENCES.

- ¹ BRITISH MEDICAL JOURNAL, April 24th, 1920, p. 567. ² Journ. Immun., 1916, vol. i, p. 201. ³ Lancet, July 31st, 1920. ⁴ N. Y. Med. Journ., January 8th, 1921, p. 45. ⁵ Arch. Int. Med., October, 1918. ⁶ Arch. Derm. and Syph., vol. ii, 1920, p. 551. ⁷ Proc. Soc. Exp. Biol. and Med., 1920, p. 93. ⁸ Journ. Pharm. and Exp. Therap., vol. iii, pp. 101 and 223.

THE DIAGNOSIS AND TREATMENT OF GASTROPTOSIS.

BY

JOHN F. HALL-EDWARDS, MAJOR (LATE R.A.M.C.),
L.R.C.P. EDIN., D.M.R. & E. CANTAB., F.R.S. EDIN.,
LATE MEDICAL OFFICER IN CHARGE X-RAY DEPARTMENT, GENERAL
HOSPITAL, BIRMINGHAM.

DURING the last few years I have had ample opportunity of studying dropped and dilated stomachs; my experience has convinced me that the existence of gastroptosis is far more common than is usually supposed, and that it is frequently overlooked.

Until the introduction of the x-ray method of examination the condition could not be diagnosed with certainty by any method then at our command.

In the ordinary abdominal examination, which is usually made with the patient lying down, the condition might not be diagnosed, although present. Even with x-ray examination, unless the patient be standing during the examination it might easily be overlooked, for the stomach not infrequently drops to a remarkably low level when the patient assumes the upright position. As a matter of fact, it is only since the introduction of the opaque meal that we have been in a position to describe the true shape of the organ or the position which it normally occupies in the abdomen.

There can be little doubt that in the majority of cases of pure gastroptosis (that is to say of cases in which there is no radioscopic or clinical evidence of stenosis at the pylorus or in the duodenum) the condition starts at or



FIG. 1.—Rest for raising foot of bed. It can be adjusted to heights varying from 8 to 11 inches.

* For certain of these I am much indebted to Messrs. Allen and Hanburys.

about the age of puberty, when the stomach commences to change from the infantile shape to the tubal form, which is found in adult life, and I venture to suggest that when severe gastric symptoms manifest themselves about this age an x-ray examination of the stomach is essential, and that if proper treatment were adopted at this period a cure might be effected.

The early symptoms of gastroptosis are not sufficiently characteristic to allow of a clinical diagnosis being made without x-ray examination, and, as a rule, much valuable time is wasted in applying the routine methods of treating dyspepsia, which may or may not relieve some of the symptoms, but which are ineffective in bringing about a cure.

Most of the symptoms ascribed to movable and dropped kidney are due to gastroptosis and not to the position of the kidneys, notwithstanding the fact that it has been stated by writers on movable kidney that this latter condition is a common cause of dyspepsia, dilatation and ulceration of the stomach.

Dr. C. W. Suckling, in his book on movable kidney, states: "I have met with two cases of fatal mucous colitis, due to movable kidney. The kidneys are attached to the colon, and when one or both fall, the colon is kinked, constipation or diarrhoea, and in some cases mucous colitis, results, which may end in perforation of the bowels and death."

"I have seen two elderly women who had suffered from movable right kidney for many years die from vomiting and haematemesis caused by the kidney becoming fixed or impacted just under the right costal arch, and causing pyloric obstruction."

In every case in which dropped kidney can be diagnosed with certainty, gastroptosis in some degree will be found to be present, and it is a debatable question as to which condition started first. Writers on the subject of dropped kidney, being aware of the fact that the kidneys can be fixed by operation have over-estimated the importance of this procedure to the exclusion of other methods of treatment which may secure relief for the suffering patient.

Gastroptosis is not infrequently found in girls from 12 to 14 years of age; it is far more common in women than in men, and is in all probability in many cases due to the wearing of badly fitting corsets, and to the suspension of heavy skirts from the waist.

Writers on dropped kidney hold that gastroptosis is due to movable right kidney dragging on the duodenum and on the upper part of the ascending colon, to both of which it is attached. Hundreds of cases of dropped kidney have been treated by means of belts or operated upon without any relief of the symptoms, and in some instances the symptoms have become worse.

A lady consulted me a few months ago suffering with severe gastric disturbances, with very evil-smelling eructations. Both her kidneys had been stitched up some years back, and at the time of visiting me she was wearing a kidney belt. X-ray examination after a barium meal showed the greater curvature of the stomach in the pelvis, nearly 4 in. below a line drawn from one iliac crest to the other. She was rigidly dieting herself, but obtained no relief from her symptoms. I treated her in the way I shall describe later, and in three months' time she had

gained over a stone in weight and could attend to her duties with greater ease than had been possible to her during the past ten years. In this case the kidney belt was actually keeping the stomach down.

The normal stomach in the upright position is a long tube the shape of the letter J—it is placed almost entirely to the left of the middle line, and the greater curvature reaches to just above or below a line drawn from one iliac crest to the other. I use this line in all my

measurements rather than the umbilicus, which in many cases is exceedingly movable. The shape of even a normal stomach differs within certain well-recognized limits—should the normal stomach be over-filled, the increase in size is obtained by lateral expansion, and not by any noticeable amount of lengthening. It has been suggested that the shape of the stomach after an opaque meal does not represent the normal, but this statement can easily be proved by experiment to be incorrect.

Gastroptosis, as a rule, first manifests itself between the ages of 14 and 30, although it may be found to be present in quite elderly people. As a rule the patients are thin, and complain of a variety of gastric disturbances. One of the most common symptoms complained of is flatulence, although x-ray examination frequently shows only a very small amount of gas present; in some cases the descending colon is found to be much distended with gas.

Many of the sufferers complain of always being hungry, and occasionally

large quantities of food are taken notwithstanding that the patients are continually losing in weight. They sometimes complain of pain, but generally of discomfort in the epigastrium and frequently of distressing palpitation. The women are markedly neurotic, and as a rule are unable to perform their household or other duties properly. In some cases they complain of a dragging sensation, with pain low down in the pelvis. Chronic constipation most commonly accompanies the condition; but in a few cases, especially in those where the stomach is much dilated as well as dropped, diarrhoea is a distressing symptom.

Gastroptosis in men is rarely so marked as in women, although the symptoms may be as bad. The worst case

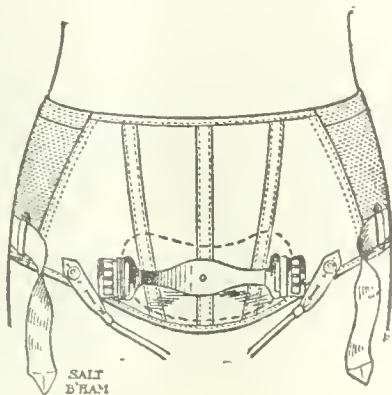

FIG. 2.—Front view.

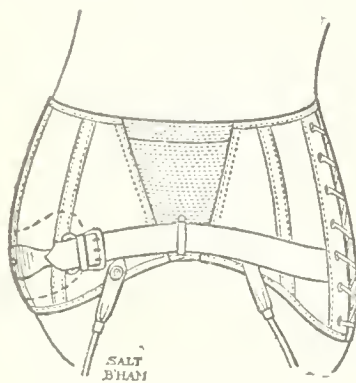

FIG. 3.—Side view.

FIGS. 2 and 3.—Supporting belt for gastroptosis. This belt is so constructed that its upper part allows of free expansion of the abdomen, whilst the lower part and pad are fixed. The pad, which is kidney-shaped and backed by a metal plate, fits the lower part of the abdomen above the pubes. Pressure is applied to the pad by a transverse spring, the spring being brought into action by webbing straps which pass from the back of the belt horizontally. The belt is supplied with elastic sides, and is made to lace up at the back.

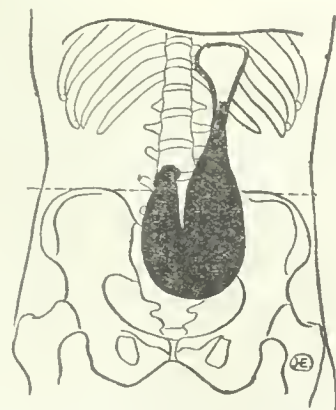

FIG. 4.—Drawn to scale from a radiograph taken immediately after partaking of an opaque meal, showing the greater curvature of the stomach in the pelvis.

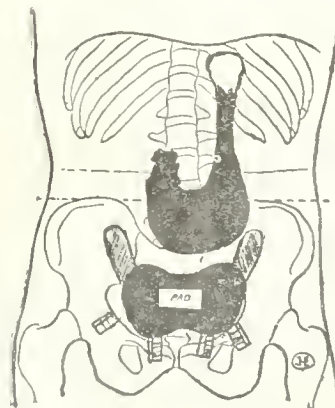

FIG. 5.—Same case as Fig. 4. Shows dropped stomach held up by belt. The position of the pad on the lower part of the abdomen is shown.

I have ever seen in a man was in a well-known surgeon who was a martyr to dyspepsia for many years but who never suspected gastroptosis until he consulted me a few months before his death; in this case the greater curvature of the stomach was situated in the pelvis 4 in. below the iliac line.

My method of examination in cases of gastroptosis consists in taking a radiograph immediately after the meal has been administered, again in half an hour, and again in an hour and a half. Should the stomach then not be empty, I radiograph it for the fourth time two hours later. It is very rare, however, that this is necessary.

The treatment I generally advise is as follows:

1. The foot of the bed should be raised from 8 in. to 12 in.; I generally find 9 in. is sufficient.
2. A special abdominal belt designed to hold the stomach up should be worn.
3. No fluid should be taken at meals.
4. Tonics, digestive ferments, alkalis, bismuth, etc., should be given by the mouth.
5. Purgatives, intestinal lubricants, or enemata should be administered.
6. Abdominal massage.
7. Swedish exercises designed to strengthen the abdominal walls.
8. Daily outdoor exercise.
9. Electrical treatment.
10. In severe cases the stomach should be washed out with antiseptics, or the patient trained to empty the stomach when a feeling of discomfort arises.

aged 27, who for years had suffered from gastric trouble and constipation. At the time she consulted me she was exceedingly thin, nervous, irritable, moody, imaginative, and shy. She was always hungry, was easily tired, was apathetic, showed a lack of interest in her work, complained of inability to sleep, and was continually taking medicines and consulting medical men without any relief of her symptoms. She had had the uterus curetted, with little or no beneficial result, and was wearing a special belt, which certainly did not fulfil the requirements. An x-ray examination showed the greater curvature of the stomach to be 4 in. below a line drawn from one iliac crest to the other. She was ordered a special belt and told to follow out treatment on the lines I have described. She commenced to improve immediately, and at the end of six weeks a radiographic examination showed that not only had the stomach greatly gained in tone, but that the greater curvature was more than 2 in. higher in the abdomen than on the previous examination. Her mental condition has greatly improved, and life had assumed an entirely new aspect to her. It was in her case that I was enabled experimentally to prove the effectiveness of the belt I had designed. On the occasion of the experiment she walked to my rooms, a distance of two miles, without her belt. I then administered the meal; the radiograph showed the stomach to be $3\frac{1}{2}$ in. below the iliac line; she now lay upon a couch, with the legs raised 9 in., for a quarter of an hour, and applied the belt whilst lying down;

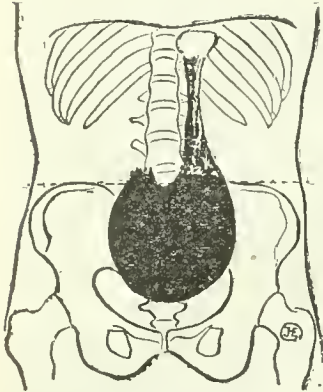

FIG. 6.—Case of badly dropped and dilated stomach.

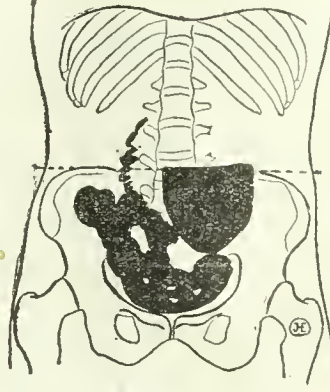

FIG. 7.—Shows the partly emptied stomach eight hours after partaking of the barium meal. Same case as Fig. 6.

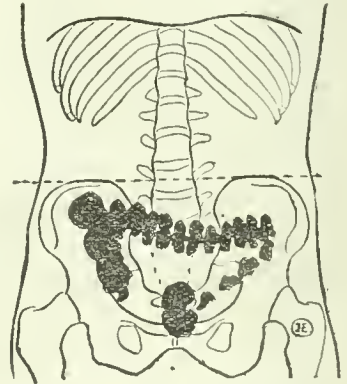

FIG. 8.—Shows the position occupied by the large intestine in a severe case of gastroptosis.

The foot of the bed can be raised by boxes or bricks; or better by a special adjustable device which has been made at my suggestion by Messrs. Salt and Son, Ltd.; it is made of hard wood with strong base, and has a suitable cup at top to hold castors (Fig. 1).

By far the most important item in the treatment is the special abdominal belt for holding the stomach up. I have previously mentioned that gastroptosis is almost invariably present in cases of dropped kidney, and I now wish to point out that the special belts designed to hold the kidneys up help to keep the stomach down. It is admitted by the advocates of nephropexy that the wearing of belts is very unsatisfactory, and that nothing short of operation is of much good. There can be no doubt that the chief reasons why the belts are a failure is the presence of gastroptosis; it will easily be understood from viewing the position of the stomach in the accompanying diagrams that a belt having pads in one or both flanks, especially if put on when the stomach is full, would have a tendency to keep it down rather than to raise it, and, as a matter of fact, might do more harm than good.

Bearing in mind the extreme thinness of most of the patients who suffer from gastroptosis, it must be obvious that a very well-fitting belt, provided with a pad which will raise the stomach, or at any rate keep it up after the belt has been put on in the recumbent position on the foot-raised bed, is essential. At my suggestion, Messrs. Salt and Son, Cherry Street, Birmingham, have designed a special belt which I have proved by actual experiment to be efficient (Figs. 2 and 3). To be effective, it must always be put on and adjusted in the manner described above, and should be taken off under the same conditions.

Figure 4 is drawn to scale from a radiograph of a nurse,

she then stood up, I took a radiograph from which the diagram (Figure 5) was made; it clearly shows the greater curvature of the stomach at or about its normal position. I may say that she still sleeps with the foot of her bed raised and has grown to like it.

In many cases of gastroptosis the stomach is not much dilated—it is simply lengthened, and the patient takes only normal quantities of food. In very severe and old-standing cases the organ may be much dilated. The worst case I have seen occurred in a young woman of 26, who complained of nightly vomiting of a considerable amount of semi-putrified food, which was highly acid and contained sarcinae. The shape and position of her stomach is shown in Fig. 6, the stomach was found to be only half empty eight hours later (Fig. 7). In this case the treatment gave considerable relief, and she was not sick for many months. Latterly, however, her symptoms have reappeared, and she is now undergoing treatment in hospital; this is the only case which may be called a failure, and as I have not seen her for many months, it is quite possible that complications have arisen.

In all cases of marked gastroptosis the large intestine will be found deep in the abdomen, and frequently the whole of it occupies the pelvis (see Fig. 8). It will be quite plain that the full stomach under these conditions, must press upon the transverse colon, causing constipation, and not infrequently distressing colitis.

When diarrhoea is a symptom it may be invariably taken for granted that a portion of the food does not leave the stomach until it has undergone fermentation. As a rule, both the constipation and the diarrhoea are greatly relieved by the treatment adopted for keeping the stomach in its normal position.

ECLIPSE BLINDNESS.

BY

WILLIAM OLIVER LODGE, M.D.,

D.O.M.S., R.C.P. & S.ENG.,

HALIFAX.

The recent eclipse aroused widespread interest, and was viewed by all and sundry under exceptionally favourable circumstances. Though the newspapers warned their readers to look at the sun only through a piece of smoked glass or through an over-exposed photographic plate, it was only to be expected that a few persons should suffer injury to sight owing to neglect of adequate precautions of this kind.

I propose to describe two cases. Since the condition is so infrequent, it may not be out of place to mention that it differs from certain allied injuries in that it is complicated neither by concussion nor electrolytic effect.

"The change is probably of a chemical nature brought about by a too prolonged concentration of the ultra-violet, chemical active rays in the retinal elements at the macula. Any damage from concentration of the heat rays is probably prevented from a reduction in their potency by passing through the refractive media."¹

The characteristic symptom is the presence of a central scotoma. When closely examined the clinical picture reveals a certain complexity of composition.

CASE I.

On April 8th, 1921, Mrs. N., a widow aged 42, not only watched the sun at intervals from about 8 until 9.30 a.m., when the eclipse was most complete, but also went to a neighbour's house, with her piece of glass, to which reference will be made presently, and looked again with her friends. Thus the total duration of exposure was about half an hour.

Dazzling and watering of the eyes ensued, but soon passed off; the principal disturbance of vision was most manifest on playing golf. When addressing the ball a shadow appeared behind it, making her feel quite dizzy, and causing her to miss her stroke. Towards the end of the week the patient noticed what she took to be double vision on glancing to the right. For instance, a chair appeared to have six legs. Whereupon she consulted Dr. Garden of Ovenden, who referred her for examination.

On examination on April 16th the vision in each eye was 6 12. The ocular muscles were normal. The red band of the Maddox rod running horizontally passed normally through the light, but the vertical red band appeared curved round the light. Upright parallel lines drawn upon a white card seemed to be bowed outwards. This metamorphopsia was present only in the right eye. The peripheral fields of vision were normal, but the right central field contained an absolute paracentral scotoma, and a relative scotoma extending from it to the blind spot. Within the relative scotoma, green objects appeared red, and vice versa.

Objective examination revealed no abnormal conditions, except 0.75 D. myopic astigmatism. The urine was normal. Slight eczema of the anterior part of the nasal septum did not suggest suppuration of the air sinuses. There were no signs of constitutional disease.

Two questions arise: first, how we are to account for the absolute scotoma being somewhat removed from the fixation point; and secondly, whether the angular interval suggests an optogram of the eclipse upon the retina.

The answer to both questions must lie in the nature of the retinal changes which have resulted from the trauma.

"Aubaret has suggested that when the natural reflex protective mechanism—contraction of the pupil, closure of the lids, etc.—fails in its object, each cell in the retina takes on its own defensive measures, which consist, as in unicellular organisms, in a withdrawal of its processes. If the injurious stimulus is extreme the retraction is permanent and the neuron chain is irremediably broken."²

Aubaret's hypothesis, however, scarcely explains metamorphopsia; still less does it account for the peculiar character of the relative scotoma, within which a green or red object excited the sensation of the complementary colour. The colour of the piece of glass referred to was indigo blue. Its transparency permitted of 6/6 vision in diffuse daylight. On looking through it at the sun for fifteen seconds one felt quite dazzled, and on gazing at a

sheet of white paper afterwards a blue image appeared, which was gradually replaced from its periphery inwards by a yellowish image (successive contrast), which persisted for five minutes.

Facts relative to the contrast phenomena indicate that the "central connexions of the optic nerves, the activities of which must be regulated by the same laws as those determined from our study of the more lowly activities of the spinal cord,"³ are concerned in their production. Again, displacement of the retinal elements by swelling to such a degree as to cause pronounced curving of the band of light in Maddox's rod test is inconceivable: if not of refractive origin it must depend upon inordinate transmission or faulty interpretation of retinal sensation.

Sir James Mackenzie teaches that symptoms are altered reflexes.⁴ Is the metachromatopsia found in cases of eclipse blindness but another illustration of this law?

CASE II.

Mrs. B., aged 42, looked at the eclipse about a dozen times, each time for about half a minute. At first she used a blue glass from a trinket set (very similar to that used by Mrs. N.); but soon discarded it, finding it gave no protection. No ill effects were noted until evening. On commencing to darn stockings the strand of wool at the needle's point seemed indistinct, though the rest of the stocking could be seen clearly enough. The following morning, on closing the right eye, a bright image like the sun occasioned some discomfort, though it would fade to bluish-green and disappear in a few moments. During the first and second weeks the objects at any distance still appeared blurred when looked at fixedly with the right eye.

The patient consulted Dr. Beetham of Bradford, who referred her to my father, with whom I saw her on April 23rd. The right vision was 6/60 for a moment, then less than 6/60; the left vision 6/10 with glasses which corrected some mixed astigmatism.

The only objective sign of disease was a patch of old choroidal degeneration behind the right inferior nasal branch of the retinal artery. This was represented in the corresponding area of the peripheral field by a small relative scotoma.

An ill-defined relative scotoma for colours was located around the fixation point; within it red objects changed to green, and vice versa, when gazed at for a few moments. The patient volunteered this information spontaneously. There was no absolute scotoma.

The symptoms in this case, though characteristic, were less marked at the time of examination than those presented in Case I. The etiology of the old-standing lesion referred to remains obscure.

Diagnosis.

When there has been a definite prolonged concentration of the sun's rays upon the macula, and the typical scotoma is found, with possibly some ophthalmoscopic confirmation of retinal trauma, the diagnosis presents no difficulty. The right eye is much more commonly affected than the left, though the vision may be impaired in both.

The onset of retrobulbar neuritis may be coincident with an eclipse. Since there would seem to be varying individual susceptibility to strong light, which cannot be accounted for by differences in retinal pigmentation, it is not unreasonable to conjecture that in certain cases of eclipse blindness there may be a toxic element at work, a point of lowered resistance having been created by the harmful rays. This would account for the aggravation of symptoms some days after their initiation. Be this as it may, it is well to exclude disseminated sclerosis, blood diseases, suppuration in the nasal accessory sinuses, and other morbid conditions which are apt to produce central scotomata.

In measuring the scotomata I am convinced of the truth of Mr. Bishop Harman's contention that in this matter speed and accuracy are synonymous; I therefore use a modification of his instrument.

Prognosis.

In giving an opinion as to the probable course of the affection the points to take into consideration are the duration of exposure to the direct rays of the sun, the degree of protection afforded by the coloured glass, if such were used, the severity of the subjective symptoms, and the extent of any lesions revealed by the ophthalmoscope.

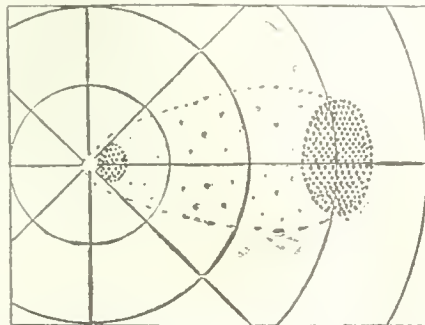

CASE I.—Chart of right visual field. There is an absolute scotoma near the fixation point and a relative scotoma extending outwards to Mariotte's blind spot.

The important fact, which will have come as a surprise to some of those who watched the eclipse with more enthusiasm than discretion, is that the resulting lesions may be to some extent permanent.

Treatment.

Regarding prevention of eclipse blindness, it is only necessary to repeat that the force of the direct rays of the sun, even when its zenith-distance is comparatively great, is very apt to be underestimated.

Once the damage has been sustained rest is the chief essential, as in all other injuries. In recent cases confinement to bed in a darkened room, a shade over the eyes, or protective glasses should be ordered, according to the severity of the symptoms. Miotics may be helpful. Various authorities recommend tonics, especially strychnine, others advise potassium iodide. Faradism is also suggested during the later stages. If the eye is ametropic, the refraction should be corrected, and Crookes's lenses prescribed. Any systemic affection likely to lower ocular immunity should be met by appropriate treatment.

Conclusion.

I have one final observation to make in relation to the symptom I have named metachromatopsia: I define it as that state of vision which imparts to an object a colour contrasting with that which it excites in a normal eye. Its presence in the central part of the visual field, in cases of eclipse blindness, signifies disturbances of the normal reflexes connected with colour vision, resulting from harmful stimulation by strong light.

This is simply a working hypothesis, put forward with the justification that:

"It is easier to evolve truth from error than from confusion."
Lord Bacon.

ADDENDUM.

Professor Whiddington of Leeds University kindly furnishes the following report with regard to the optical properties of the sample of blue glass:

"I should hardly have thought that there was any great transmission of extreme ultra violet light through glass of this nature, but I will settle the point by getting a photograph showing the absorption spectrum in the visible and ultra violet regions. One would expect the red end of the spectrum to be cut off completely, and perhaps an absorption band in the yellow-green region, and then again complete darkness in the extreme ultra violet. Since the eye is more sensitive to visible light in the yellow-green than to any other, one might expect damage to be done to the eye perhaps if the sunlight of this colour were not sufficiently strongly absorbed."

REFERENCES.

¹ Treacher Collins and Mayou in *Pave's System of Ophthalmic Practice*. ² Anbaret, A. "d" O., xxvii, 1907, cited by Parsons in *The Pathology of the Eye*. ³ Starling, *Human Physiology*. ⁴ Mackenzie, *BRITISH MEDICAL JOURNAL*, 1921, vol. i, p. 147.

THE TREATMENT OF URETHRAL STRICTURE.

BY

P. L. GIUSEPPI, F.R.C.S.ENG.,

FELIXSTOWE.

URETHRAL stricture is one of the most difficult of surgical conditions to treat, and this perhaps accounts for the fact that so little has been done to modernize its treatment. This is well shown by the extraordinary paucity of papers which have been written on this subject during the last ten years; moreover, most of the papers that have been written only repeat old views and theories and add nothing to our knowledge.

The accepted teaching seems to be that urethral strictures are best treated by instrumental dilatation; this method, as we are all well aware, has been most disappointing, and that for many reasons—firstly, the difficulty of the operation; secondly, the long convalescence; thirdly, the pain produced; and lastly, the great frequency of recurrences unless the patient returns weekly, monthly, or yearly for the passing of sounds. The next method to be adopted in cases of failure by dilatation due to the stricture being impermeable or intractable is that of external urethrotomy. The same tendency to relapse follows this operation. The third method is internal

urethrotomy, but of this many surgeons seem afraid because of the excessive bleeding and extravasation of urine which follows the operation, and we might add the tendency to recurrence.

The greatest advance in the treatment of urethral stricture was made by Otis, who taught that dilatation should not cease with the passage of a No. 12 sound, but should be continued up to No. 20 or 24 (English measurements). He clearly showed that the normal male urethra will allow the passage of sounds of this size, and that it was due to the insufficiency of the dilatation that strictures relapsed whatever had been the method of treatment adopted.

This new doctrine did wonders for the treatment of urethral strictures, but still two drawbacks remained: the first was the pain involved and the length of treatment required in the passing of sounds, and the second was the length of stay in bed, and, after external urethrotomy, the difficulty of keeping the patient dry.

The new methods which I advocate are, I believe, a step forward, and certainly curtail the length of treatment, avoid all unnecessary pain, and keep the patient dry and comfortable in bed.

Unless a stricture can be easily dilated with sounds, or unless it is impermeable or does not allow of the passage of a No. 1 (English) catheter or sound, I believe that the correct treatment is internal urethrotomy. If the case is one in which this operation is indicated the internal urethrotome is passed into the urethra after the usual antiseptic precautions have been taken, and gas and oxygen are administered; the knife is then uncovered and the instrument withdrawn, and a number of previously oiled sounds passed into the bladder until a No. 20 or 24 is passed. The best instrument is Lockwood's modification of a Civiale's urethrotome. This enables any stricture to be divided from behind forwards, provided a No. 1 (English) bougie can be passed. I have now performed twenty-five operations of this nature, and have not had a single recurrence. Most of the cases have been seen six months after the operation, and a large proportion two years after. The after-treatment is simple. A catheter No. 20 is tied in for two days. A sound is passed once weekly for two weeks and then monthly for two months, and then after a year's interval. There has been no excessive haemorrhage or extravasation of urine, no rise of temperature, except occasionally to 99° F. at night, and no death.

Should the case be one in which external urethrotomy must be performed, the method I advocate is the complete suture of the urethra and skin after the performance of the operation. Such a method has, as far as I know, never been suggested before, probably because of the fear of extravasation of urine. I do not pretend that all cases can be dealt with in this way; strictures extending over a large extent of the length of the urethra cannot be so treated, but all others not complicated by abscesses or sinuses can. Out of a series of thirty-one cases of external urethrotomy I have performed this operation in twenty-five; of the remaining six, four were operated on several years ago. As soon as the No. 20 catheter is passed into the bladder the edges of the urethra are brought into contact by a continuous catgut suture passed through the muscles and tissues of the bulb, but not through the urethral mucous membrane. All cozing from the bulb now stops. The skin is sutured, and a small drainage tube left in for twenty-four hours.

I have seen no rise in temperature other than to 99° F. in a few cases. I have had no extravasation of urine, and with the exception of two cases early in my series in which urine passed through the wound for a week and ten days respectively, every case has healed by first intention.

In my opinion the operation saves so much pain and inconvenience, and so much loss of time, that I cannot imagine why it should not come into common practice. In only two cases has the patient been in bed for more than eight days.

A LABORATORY for mycological research has been founded at Operto under the direction of Professor Froilano de Melo.

IN Marseilles 4 per cent. of the school children are affected with trachoma, which has been introduced by labourers from North Africa.

TWO UNUSUAL CASES OF ABDOMINAL TUBERCULOSIS.

BY

E. G. SLESINGER, O.B.E., M.S., F.R.C.S.,
ASSISTANT SURGEON, GUY'S HOSPITAL.

The two following cases appear to be sufficiently unusual to be worth recording, partly on account of the difficulties in diagnosis and partly on account of the apparent rarity of mesenteric abscess at the ages at which it occurred in these two patients.

CASE I.

H. P., a male infant aged 5 months, had been noticed to appear ill for ten days. Diarrhoea was present during the whole of this period, the stools being greenish and offensive, but not containing any blood. The child had been taking its food badly and had vomited four times before it was brought to the hospital, when it was at once admitted.

On admission he looked extremely ill. He was pale, with sunken face and restless. The abdomen was very greatly distended, appeared to be tender, was resonant in the middle and dull in the flanks. The child vomited once in the ward, but the vomit was in no way characteristic. Pulse very feeble, 150 to 160, temperature 102°. The abdomen was too tensely distended for anything to be palpated, and the most probable diagnosis seemed to be a pneumococcal peritonitis.

Laparotomy was performed under a spinal anaesthetic. On opening the abdomen a large quantity of purulent fluid and intestinal contents escaped, and a loop of intestine, showing a perforation, presented. The bowel wall in the neighbourhood and over most of the coil was oedematous and obviously ulcerated. The perforation was closed and was reinforced with an omental graft owing to the difficulty of making the sutures hold satisfactorily. It was noticed that the greater part of the pus came from a mass which could be felt in the abdomen, and this on further exploration proved to be a mesenteric abscess, from which several ounces of pus were evacuated. A tube was left draining the abscess cavity and Carrel instillation of the peritoneal cavity with saline was instituted. The child appeared to rally at first, but died the following morning.

Post-mortem examination showed extensive tuberculous ulceration of the small intestine; one of the ulcers had perforated, and the cavity of the mesenteric abscess was in relation to a ruptured tuberculous caseating gland.

CASE II.

F. J., a male aged 34, gave a history of pain in the left iliac fossa for three weeks, the pain being also referred to both lumbar regions. It was not influenced by food or exercise, but was a good deal worse at night. The patient had been extremely constipated, but had never vomited. He was admitted to hospital as a case of subacute intestinal obstruction. There was some abdominal distension, with tenderness over the left iliac fossa; a tumour of somewhat vague contour, but of firm consistency, could be palpated in this region; manipulation was painful. The tongue was furred and dry, and an enema failed to act. Temperature 99.4°, pulse 100. The tumour felt like an abscess walled in by bowel, but as auscultation and palpation revealed the caecum in the normal position and apparently not connected with the tumour, a tentative diagnosis of an abscess in connexion with a Meckel's diverticulum was made. Diverticulitis was considered, but seemed unlikely on account of the mobility of the tumour.

Laparotomy was performed, and the tumour explored. The appendix was attached by its tip to the tumour, and was secondarily somewhat inflamed, and consequently removed. A well formed Meckel's diverticulum was separated from the loops of bowel bounding the mass, but was seen to be normal apart from some injection. The mesentery of the small intestine was noted to be very thick and short, the bowel being bound down almost to the posterior abdominal wall; on separating the loops, about a pint of faecal-smelling pus was evacuated. On exploring the cavity, it was found to be bounded by mesentery and bowel, and from one wall half of a semi-calcareous gland was removed. In spite of the faeculent odour of the pus, cultures remained sterile on incubation. The abscess cavity was drained, and the patient made an uninterrupted recovery, the track of the drain healing quickly.

The unusual points about the first case were the age of the patient—perforation of a tuberculous ulcer in infancy must be very uncommon—and the presence of a solitary well-marked abscess originating in a tuberculous mesenteric gland. The condition of the child was such that death appeared inevitable, but it was felt that operation offered the only chance.

There appears no doubt that in the second case the mesenteric abscess originated in an old tuberculous gland, and a few calcareous glands were felt elsewhere in the mesentery. The signs and symptoms were exactly those of an appendicular abscess occurring on the left side, but the caecum could be easily felt on the right. The tumour was comparatively freely movable in all directions, which was unlike diverticulitis; it felt like a walled-in abscess

of some kind. There was no history suggesting tabes mesenterica during childhood, nor was there anything to account for the sudden flaring up of a tuberculous gland which must have been present for some time. The faeculent odour was probably due to the commencing peritonitis on the adjacent coils of intestine; in view of the fact that cultures remained sterile, it is difficult to account for the development of the abscess by organisms passing from the bowel along the lymphatics, which at first sight appeared the most probable explanation.

Memoranda:

MEDICAL, SURGICAL, OBSTETRICAL.

PAIN IN PAROXYSMAL AURICULAR FIBRILLATION.

PAIN is not a common accompaniment of auricular fibrillation (Mackenzie), and the following case therefore seems of sufficient interest to be recorded:

A man, aged 52, had a "cold" at the end of October, 1916. On November 3rd, on his way to business, he noticed that he did not walk quite so easily as usual owing to tightness in the chest, and when he got on the top of a tram he felt fluttering in his chest. This continued, but he managed to do his work. Next day he had pain in the left chest, which made it difficult for him to take a long breath. When seen on November 5th he lay in bed, breathing easily, but complaining of fluttering and a severe pain over a small area of the front of the left chest at the level of the third rib near the sternum. Here there was a patch of skin, about 1 in. in diameter, hypersensitive to pin-prick and light pinching. The pulse rate was rather rapid (95 to 100) and grossly irregular. The fluttering was chiefly felt at the same place as the pain. No dilatation of the heart could be demonstrated; there were no murmurs and no friction sound. A polygraph curve showed ventricular venous pulse and absolutely irregular rhythm (auricular fibrillation). The pain continued during the following days, though less severe. On November 14th the pulse was found to be regular, at 56 per minute. The previous evening he had felt rapid relief from pain, and found that the irregularity of the pulse had disappeared. A polygraph curve now showed the normal rhythm.

Two years later, after a slight illness, he had another attack of fibrillation, induced apparently by running for a tram, and the pulse has remained irregular to the present time. Fortunately for the patient the heart rate is moderate, ranging about 70, and by planning out his work so as to avoid hurry he is able to carry on an active life.

The pain in this case did not appear immediately after the onset of fibrillation, but only when, the patient having endeavoured to carry on his work for a day, an additional strain was put on an embarrassed circulation. Rest in bed lessened the pain, but it did not cease until the normal rhythm was restored, and then its disappearance was rapid and complete.

Hull.

E. E. LASLETT, M.D.

GLANDULAR FEVER.

I HAVE recently observed in my practice, which lies in the extreme north of Scotland, a number of cases of "sore throat," usually slight, accompanied by cervical glandular enlargements quite out of proportion to the condition of the fauces and pharynx. I may say that a few of those cases showed a striking resemblance to cases described as glandular fever.

The glands involved were those situated beneath the sterno-mastoid muscle, about the upper part of its middle third and below the level of the angle of the jaw. Lack of symmetry of the two sides was also a feature. The skin over the glands was not reddened or oedematous. The glands remained discrete and showed no tendency to suppurate, and some of them were as large as a pigeon's egg, and even larger. As already mentioned, the throat condition was slight, and in at least one case the throat appeared to be quite normal.

The history of the most recent case I observed is briefly this:

A girl, aged 4½ years, complained of being unwell one evening, and the mother noticed a swelling on the left side of the neck. There were no other children in the house. When I saw her next morning the child presented the following clinical picture: Pyrexia with rapid pulse, vomiting and furred tongue, great enlargement of cervical glands on the left side, below the level of the angle of the jaw, situated roughly under the middle third of the sterno-mastoid muscle; no glands were palpable on the

right side. The high fever continued for four days, and on one occasion the thermometer registered 104.2° F. After the fourth day the temperature fell and the glands began to decrease in size. The glands were tender. The fauces and pharynx were normal in appearance, and there was evidently no pain on swallowing. There were no other enlarged glands. The spleen was not palpable, and there was no enlargement of the liver. The skin over the glands was not reddened or oedematous, and the glands did not suppurate.

Convalescence was slow; the glands gradually decreased in size until, on the twentieth day from the onset of the illness, the swelling had completely disappeared from the neck, but the glands were still quite easily palpated. Previously the child had enjoyed excellent health, having never had any previous glandular enlargements.

These observations, coming from a remote part of the country, may be of some interest.

Wick, Caithness.

JAMES LEASK.

EIGHT SUCCESSIVE BREECH PRESENTATIONS IN THE SAME PATIENT.

I HAVE just attended, in her eighth confinement, a patient whose obstetrical history is so unusual as to seem to me worth recording. In all her eight labours the presentation has been a breech; in most of them the labour has not been unduly difficult, though in at least two (including the one for which I have just attended her) the child was born with suspended animation; I had to perform artificial respiration—in both cases, I am glad to say, with satisfying results. The mother of the patient tells me she had at least one child a breech presentation; one of the patient's sisters (who has, as yet, only one child) also had a breech presentation.

The woman is 32 years of age, perfectly strong and healthy. In my experience of nearly fourteen years in practice I have met relatively so few breech presentations that this patient has interested me greatly—obviously there must be some explanation of this peculiarity.

J. ROBERTSON HALL, M.B., Ch.B.

Fence Houses, co. Durham.

Reports of Societies.

THE LIVERPOOL MEDICAL INSTITUTION.

The Antiquity of Syphilis.

THE last ordinary meeting of the session of the Liverpool Medical Institution was held on April 28th, with the President, Dr. J. E. GEMMELL, in the chair, when Dr. FRANK H. BARENDT read a note on "The antiquity of syphilis." The earliest record, he said, was found in chapter xxv of the Book of Numbers, but it was on apparently insufficient grounds that syphilis had been termed Job's disease. Hippocrates described various diseases which could be nothing other than syphilitic affections of the organs implicated. Mythology contained references and *ex voto* tablets to divinities plainly revealed that the ancients were acquainted with syphilis. Aretaeus gave an account of destruction of the palate, uvula and fauces; Celsus under various skin diseases set forth a lucid account of syphilides, condylomata and gummata. One of Martial's epigrams was quoted in which the play on the word "ficus" was cunningly devised by that ancient author. Horace mentioned in one of his satires "morbus campanus" as peculiar to profligates, and his description is that of tertiary syphilis. The word "syphilis" was in fact a proper name used by Fracastoro, an eminent poet and physician, who wrote a poem entitled *Syphilis seu morbus Gallicus*. Syphilis, a shepherd, for blaspheming the sun, was afflicted with a loathsome disease. The eminent French physician Sauvages introduced the hapless shepherd's name into nosology, and the word was now used for *lues venerea* throughout the world. *Lues venerea* was not used to depict a disease so much as the result of excessive venery. In the Middle Ages, about the time of the discovery of America, our knowledge of syphilis became more exact, aided, perhaps, with the invention of printing, and its differentiation from leprosy, tuberculosis, pellagra, and many skin affections, was established. The origin of the disease, which this knowledge, in a sense new, was used to describe, was referred to America. Dr. Barendt considered, however, that the disease syphilis was as old as the annals of mankind, and that all records supported this view.

The Electro-cardiograph.

DR. ISAAC HARRIS read a paper on the value of the electro-cardiograph in diagnosis and prognosis. He pointed out that whilst the electro-cardiograph had its limitations, there were a great number of affections of the myocardium which could only be diagnosed by means of this instrument. Various instances were given of obscure cases, cases entailing degenerative changes of the heart muscle and the bundles, in which, but for the cardiograph, it would be impossible to give a diagnosis. The practical value of the cardiograph in treatment was pointed out and slides were shown demonstrating the influence of digitalis, caffeine, and camphor on the cardiogram. A case of auricular fibrillation complicated by degeneration of the heart muscle was given as an illustration of the value of electro-cardiography as a guide in treatment. Digitalis was contraindicated in such cases, but the condition could not be diagnosed without the cardiograph. Dr. Harris pointed out that in his experience all cases of heart-block, partial or complete, which were not complicated by degeneration of the heart muscle never gave rise to the Adams-Stokes syndrome; but, on the other hand, whenever the syndrome appeared, there also was found degeneration of the heart muscle. Mackenzie's contention that the syndrome was due to a sudden transition from normal to ventricular rhythm was considered untenable for the following reasons: (1) Heart-blocks not complicated by degenerative changes of the muscle never gave rise to the syndrome, although they too must show at one time or another a moment of transition from the normal to ventricular rhythm; (2) the prognosis of cases which exhibited the Adams-Stokes syndrome was much worse than that of cases of ordinary block, but, according to Mackenzie's contention, the syndrome could only appear in the first stages of heart-block. The prognosis ought to be better in the latter cases than when the block became complete. The conclusion was that the symptom was due to degeneration of the heart muscle.

Dr. JOHN HAY said that it was essential to understand what an electro-cardiogram represented. It gave in graphic form the variations in electric potential associated with each systole of the heart and nothing more. A normal contraction of the heart conformed to a certain standard electro-cardiogram. If for any cause any portion of the heart beat abnormally, there was a change in the curve. Fibrillation, flutter, extra-systoles, heart-block, relative hypertrophy of either ventricle, all presented their characteristic electro-cardiogram because some portion of the heart was contracting in an abnormal manner, and a recognition of these variations in the electro-cardiogram enabled a certain diagnosis to be made, and naturally this precision in diagnosis furthered accuracy in prognosis. Its value in the diagnosis of certain forms of heart disorder was beyond question. By the electro-cardiogram an uncertain was replaced by a confident opinion. In prognosis it was not possible to speak with the same assurance, as this part of the subject had not received the same degree of attention. A sufficient number of patients had not been observed over periods long enough to justify any considered opinion, but there were indications that this field of work would yield information of considerable value. Variations in the ventricular complex had their significance as clear indications of myocardial damage—in arborization block for instance. At present data were being collected and patients watched who presented these bizarre forms of "Q.R.S. complex." At the Royal Infirmary all cases of auricular fibrillation were being noted in which this unusual form of electro-cardiogram was present, and the extent to which it affected prognosis was being observed. Again, in patients suffering from fibrillation there was a small percentage in whom ectopic beats occurred. Such ectopic beats could only be recognized by means of an electro-cardiogram. The prognostic value of the abnormality was not yet settled, though by some it was considered to indicate a more serious outlook. Certain variations from the normal were already recognized as of definitely evil omen, as, for example, the characteristic electro-cardiogram found when there was damage to one or other main branch of the auriculo-ventricular bundle. This indicated myocardial damage. The prognosis in cases of angina pectoris was notoriously uncertain and presented many difficulties, and any help was welcome. The electro-cardiograph sometimes afforded that help.

Mr. FRANK JEANS read a note on the uses and limitations of the cystoscope, with special reference to those bladder conditions in which the cystoscope was the sole method of diagnosis, such as uric acid stones and papillomata in the bladder. Other conditions in which it was irreplaceable were: (1) For dilating the ureter with a ureteral catheter to aid the passage of small stones; (2) in the diagnosis of hydronephrosis by distension of the pelvis through a ureteral catheter; (3) in the localization to the ureter of shadows shown by radiography; and (4) in estimating the efficiency of the two kidneys.

Mr. NEWBOLT described a case of cyst of the brain occurring in a youth aged 17. The patient had had a compound fracture above and behind the left ear when two and three-quarters years old, resulting in a hernia cerebri. This healed over, and he was well for twelve years when fits started. As these increased in intensity, though they left no after-effects, Mr. Newbolt exposed the old scar and found a cyst communicating with the lateral ventricle. This was drained; there was a copious flow of cerebro-spinal fluid for some weeks, a high temperature, loss of power over the right limb, and aphasia. Eventually a good recovery ensued.

THE INFLUENZA EPIDEMIC IN THE NAVY.

At the meeting of the War Section of the Royal Society of Medicine on May 9th Surgeon Commander S. F. DUDLEY, R.N., related a few observations on the influenza epidemic as it affected the Royal Navy. He referred principally to the epidemic of 1918, though he also touched on the epidemic at Portsmouth at the beginning of 1921. He began with some remarks on bacteriology. He said that he had been able to demonstrate *B. influenzae* in association with the cases, save in the spring cases of 1918, when he used an unsatisfactory technique. He thought that this organism was the most likely cause of the epidemic, but it was curious that within the last two years he had swabbed batches of men—260 in all—who exhibited no signs of influenza, but were mostly venereal convalescents at Haslar, and in half of them he found this organism in the nose and throat. The probability was that the organism which went by this name was really a group of organisms, and the variation in the morphology of the different strains supported this view. The reason for these numerous influenza carriers might be that only certain strains of *B. influenzae* were capable of producing influenza symptoms. He thought it possible that if the whole population of the country had been continuously examined during the last two years it would be found that almost all persons at some time or other for a longer or shorter period harboured influenza-like organisms. Virulent carriers, however, did exist, as well as harmless carriers, and it seemed reasonable to suppose that it was the infective individual who adapted himself to the parasite rather than the parasite which adapted itself to its host. His theory to explain the number of harmless carriers was that the virulent strains which started an epidemic became eliminated, and the organism succeeded in adapting itself to its environment and became the highly infective but innocuous strain found in these so-called carriers. The great variation in influenza attack was due (1) to variation in the primary organism, (2) to variation in individual susceptibility, (3) to different combinations of bacterial flora causing the illness. Whatever the primary parasite might be, it depressed the resistance to bacterial invasion, so that any pathogenic organism in the neighbourhood seemed to attain greater virulence, the result being a complex disease in which the secondary invader might play the more important part. The fact that the pulmonary complications of influenza were generally present from the onset suggested that the so-called secondary infection was not secondary in time, but was contracted simultaneously with the primary infection. Possibly influenza was always a double infection, with *B. influenzae* plus another organism, whose assistance made the influenza bacillus a more dangerous parasite.

Surgeon Commander Dudley then related the history of a few ships of the Royal Navy during the epidemic of 1918. As an instance of high infectivity and high virulence he gave the case of H.M.S. *Africa*, where, among a ship's company of nearly eight hundred, the attack rate was 75 per cent., and the case mortality 9 per cent.; and H.M.S.

Britannia, where the attack rate was 58 per cent., and the case mortality 7.5 per cent. On H.M.S. *Revenge*, with a company of 1,200, the attack rate in the first wave (spring, 1918) was 17 per cent., and in the second wave (autumn, 1918) it was 20 per cent. He believed that the attack rate to be expected in a thoroughly infected ship was 25 per cent. in the first wave and 25 per cent. in the return wave. A ship's company—and possibly this was true of the population as a whole—consisted roughly of a quarter who were highly susceptible, succumbing at once; a quarter who were less susceptible, succumbing on the return wave, while the other half had natural immunity. In the early part of 1921, at Portsmouth, one ship reported 82 cases, or 7 per cent. of her company, and another 61 cases, or 6 per cent. Many of these cases were little more than feverish colds. It might be that the strain of influenza of 1921 was totally different from that of 1918, but he inclined to the view that by 1921 about 5 per cent. of the population had become highly susceptible, 5 per cent. ordinarily susceptible, and 90 per cent. fairly immune to the influenza virus, as against 50 per cent. susceptible and 50 per cent. immune in the 1918 epidemic. He believed that disinfection sprays and gargles and isolation were of little effect in the crowded condition of a battleship, where 1,000 men might be living within an area, including all decks, of a quarter of a square mile, but that disease could be kept from spreading from ship to ship and from shore to ship if the quarantine was made absolute. Prophylactic vaccination probably diminished the incidence to one-third and the case mortality to nearly one-twentieth.

Sir ROBERT HILL, Medical Director-General R.N., who presided, said that what struck him about the epidemic of 1918 was its similarity to the epidemic of 1889-90. The earlier epidemic began in exactly the same way—a very sharp onset, collapse after a day or two days, and rapid recovery. This was followed in the late autumn of 1890 by a bronchopneumonia which killed old people and young children. In the serious return wave of the epidemic of 1918 the boys in the navy and the older men—that is, the senior officers, who were the oldest men aboard, and were in their fifties—got off better than men in their thirties, among whom, in the destroyers particularly, there was a considerable mortality. This development in severity had its parallel in measles. The first cases of measles in a school were nearly always mild, and the outbreak got more and more virulent until nearly half the school might be down.

CARDIOSPASM.

At a meeting of the Edinburgh Medico-Chirurgical Society on May 4th, 1921, Emeritus Professor F. M. CAMPBELL, presiding, a paper on cardiospasm, congenital narrowing of the oesophagus, and oesophagectasia, was read by Mr. D. M. GREGG.

In *cardiospasm* other symptoms were equivocal, but the one essential symptom was dysphagia, which must be recurrent and not constant. It was difficult to account for the site of spasm at the lower end of the oesophagus, for here the anatomical and physiological arrangements of a sphincter were absent, and the analogy between cardiospasm and congenital pyloric stenosis did not therefore exist. Further there was no hypertrophy of muscle, and other alleged alterations in the oesophageal wall were very doubtful. But it was probable that there was a nervous element in causation. Some typical case-histories were given.

In *congenital narrowing* of the oesophagus the condition was seldom noticed at birth or in infancy because of the fluid diet, but was revealed later by the constant regurgitation of solid food, the necessity of a fluid diet, and the interference with growth. They might be called cases of oesophageal infantilism. The condition was compatible with long life, as illustrated by the case of a lady aged 82 years. Details of a case in a girl aged 12 years were given. She was much undersized and 47 lb. in weight, but was of normal intelligence; there was a history of vomiting, noticed soon after birth, but marked from four months. After infancy there was inability to swallow any food, except fluids, and the child lived chiefly on milk. Sir Everard Home's specimens and cases in the Royal College of Surgeons Museum, London, were alluded to, and also those doubtful cases of so-called "congenital web" in which the dysphagia was cured after the passage of

bougie. The true case of congenital narrowing was not amenable to dilatation by bougie; the only treatment was a suitable modification of the diet. The site of narrowing varied, and also the degree of stenosis, so that in a slight case diagnosis might only be made at an advanced age, when the significant history of life-long care in swallowing was obtained. Diagnosis was established by the use of the bougie and by radiography. As to the condition of the gullet, at the site of narrowing there was a normal structure and relation of the various coats, and above it there was neither hypertrophy nor dilatation. It seemed probable that these cases were specially liable to cancer.

Oesophagectasia was a condition of dilatation of the oesophagus, causing dysphagia. It might be congenital and so severe as to be fatal. But often it did not cause symptoms till middle life. Illustrative cases in a female aged 57 and in a male aged 57 were detailed. In neither was there evidence of a congenital condition. In the former there was a history of twenty years' recurrent return of food, aggravated by the recumbent position; in the latter the onset of food regurgitation was quite sudden. Parkes Weber had reported similar cases, and believed that the dominant factor was an oesophageal obstruction, organic or spasmodic, followed by weakening and dilatation of the proximal oesophagus. But a case of obstruction at the lower end of the oesophagus in a woman aged 73, the result of an adjacent healed gastric ulcer, where the rest of the oesophagus was healthy, was against this view. The speaker's view was that the condition was due to some nerve paralysis, a neuro-muscular affection in which the longitudinal oesophageal fibres were primarily at fault. What first happened was a failure of the *vis a tergo* propelling the food down the gullet, and then the normal anatomical exit, though remaining of the same calibre, became relatively insufficient and obstructive.

Dr. LOGAN TURNER said that the first group of cardio-spasms were rather cases of non-relaxation of the lower end of the oesophagus. In them a bougie could always be passed, and if not, it was organic stricture. Dilatation in these cases either relieved or cured. They occurred equally in both sexes, and at any age. But where the obstruction was above the cardia the cases were nearly all in women, and cancer was frequent. Mr. J. W. DOWDEN reported a case of sudden and complete oesophageal obstruction produced by a long pharyngeal polypus in a young man. Drs. A. GOODALL, J. S. FOWLER, G. M. ROBERTSON, SOMERVILLE, and Mr. SCOT SKIRVING also took part in the discussion.

Mesenteric Lymphadenitis Simulating Appendicitis.

Mr. J. W. STRUTHERS read a paper on this subject, commenting first on the rarity of suppurative lymphadenitis in mesenteric glands, and then on the great frequency of their tuberculous infection. Sometimes acute inflammatory reaction occurred in these glands, causing symptoms very similar to those of appendicitis. A number of case-histories were read, with the operation findings of a healthy appendix, but of acutely inflamed tuberculous glands in the adjacent mesentery. The clinical features were those of acute appendicitis, acute abdominal pain, tenderness and rigidity in the right lower quadrant, with vomiting and fever. The symptoms were, perhaps, less severe; the tongue not so heavily furred, and the breath had not the typical odour; but, in the interest of safety, the differential diagnosis was not possible without laparotomy. He had operated on about a score of these cases in two years, and in the same period had had 176 cases of true appendicitis.

Mr. A. MILES agreed as to the difficulty of diagnosis, but said that in his experience the cases had been of milder clinical type than those of appendicitis; while Mr. W. J. STEWART said his attempts to differentiate the two conditions clinically had failed and that laparotomy had often revealed the one condition when he had expected the other.

DR. BEDFORD PIERCE, F.R.C.P., ex-President of the Medico-Psychological Association of Great Britain and Ireland, is resigning his position as Medical Superintendent of the Retreat Mental Hospital at York at the end of the year, after nearly thirty years' service. The committee of management has appointed as his successor Dr. Henry Yellowlees, F.R.F.P.S., at present the Senior Physician and Deputy Physician-Superintendent of the Royal Edinburgh Asylum, Morningside.

Rebuelus.

SENSORY APHASIA.

To his great work on the pathology of the brain¹ Professor HENSCHEN, of Stockholm, has now added a sixth part devoted to the consideration of sensory aphasia. Out of the literature on aphasia he has collected over 700 cases and classified them according to the anatomical lesions found after death. Cases 369 to 703 are considered here. The reference to each is given, and an abstract of the case, with a critical commentary, is presented. He hopes to follow up this part with a seventh dealing with Motor Aphasia, and later to add general conclusions to which he has come from the study of the whole subject.

The author remarks that at the present day observers are not yet agreed even upon fundamental principles, and Dr. Henry Head's recent contributions have brought this home vividly enough to English readers. There are two main schools of thought—the anatomical, headed by Broca and Wernicke; and the physiological-psychological school of Trousseau, Kussmaul, Sachs, Jackson, Monakow and Freud. Professor Henschel is emphatically of the anatomical school; he considers psychology and philosophy as ornamental rather than essential to the study of aphasia. Nevertheless he feels that the followers of Wernicke are largely responsible for the chaos in which the subject at present is; they have accepted his views too uncritically, so that Piek could declare that the era of cerebral localization is over. There is an enormous amount of material published on the subject of aphasia, but most of it is incomplete and worthless, the work of Touche, Moutier and Bernheim being a brilliant exception.

Hammerberg, Brodmann, Ceeile and Oskar Vogt, Flechsig, and Campbell have shown that the cortex is divisible functionally into small territories, and Henschel's aim is to apply these findings to the study of aphasia. He insists on the importance of the discrimination of word hearing from the simple acoustic sensory centre, and of word blindness from the simple visual sensory centre. Word deafness and word blindness are quite distinct entities, the former associated with lesions of the posterior two-thirds of the first left temporal convolution, the latter with lesions of the left angular gyrus. Lesions of parietal or occipital areas have no part in either. Tone deafness is related to word deafness, but the lesion must lie nearer the temporal pole; loss of recall of words is ascribed to lesions of the second and third left temporal convolutions. Spontaneous agraphia appears when word blindness is severe, and so does inability to write from dictation and to copy words. These failures are associated with the cortex only of the angular gyrus, and are not primarily due to lesions of the underlying fibre bundles. Professor Henschel thinks that the letters of a word are seen, and that these impressions are transmitted to the angular gyrus, where they meet other higher associations which give meaning to the word. Some individuals read letter by letter, others take in the general impression of the whole word at once.

The author's views on the functions of the two hemispheres are very interesting. He draws attention to Wundt's theory that language has developed from gestures, and that, as gestures are pre-eminently the creation of the right hand, the highest conscious functions of speech are the work of the left hemisphere. The study of cases of non-progressive lesions of the left first temporal gyrus shows that in about 30 per cent. of them the primarily existing word deafness diminishes as time goes on. The right first temporal convolution is "an organ of automatic, senseless, unconscious acoustic speech comprehension, or rather of speech hearing." But in these cases it can develop and partially take over the functions of the corresponding left area. This substitution is not likely to occur if it has not appeared within eight months, and it never takes place after four years. When the left temporal area is first affected the echolalia which may occur is due to the unchecked activity of the right area. Similarly with word blindness, the right

¹ *Klinische und Anatomische Beiträge zur Pathologie des Gehirns.* Von Dr. Salomon Eberhard Henschel, Professor Emeritus am Königl. Carolinischen Medico-Chirurg. Institute, Stockholm, vorm. Direktor der Medizinischen Klinik. Sechste Theil, über Sensorische Aphasie. Mit 11 Tafeln. In Commission. Nordiska Bokhandeln, Stockholm, 1920.

angular gyms can take over the work of letter reading but not that of words. Senseless reading is due to uninhibited activity of the right gyrus.

Professor Henschen concludes that word blindness and word deafness are quite distinct from each other. Each is related to a particular area of the cortex, and he would extend this strict localization to the finest elements of speech. The marvellous educability of the brain he relates to what he calls "the tremendous uncultivated field" of the right hemisphere, which at present performs only lowly functions of the mind. He pleads for the early logical training of the young and for in future laying stress above all on intellectual development; this latter depends on the conservation of racial experience.

At present the whole subject of aphasia promises to enter the melting-pot once again, but this work correlates and renders available for the first time all the essential data hitherto garnered, and, whatever theories hold to day, it will remain one to which future investigators will turn for reference. "Res Manent" appears on the title-page of this monograph, and the motto is appropriate.

FREDK. W. MOTT.

OPHTHALMIC OPERATIONS.

AMONG the numerous textbooks on ophthalmic operations, that of TERRIEN,² in the French tongue, deserves a very high place. The first edition appeared in 1902, and as ophthalmic surgery has been much amplified in the past twenty years, more particularly in the operations for glaucoma and cataract and those for removal of intra-ocular foreign bodies, it was time that a representative expression of French work should appear. French surgery led the way in the elaboration of the newer types of operations performed for the relief of chronic glaucoma, and we may confidently assert that much of the improvement noticed in the results of recent methods of operation is due to the pioneer work of Elliot and Herbert in this country, and of Lagrange in France. In this volume the matter is arranged in three sections.

A preliminary short statement of pre-operative technique, preparation of the patient, instruments and the operating room, anaesthesia general and local, and the surgical anatomy of the parts, is followed by a section dealing with operations on the globe, while the last part is devoted to those on the lids, muscles, and adnexa. In each chapter a regular plan is followed: the indications for the operation are given, the method of performing it is described, and the complications which may arise and how they can best be guarded against and dealt with if they should occur are discussed. A very liberal allowance of illustrations and diagrams helps materially in elucidating the text.

The operation of sclerecto-iridectomy, devised by Lagrange of Bordeaux for chronic glaucoma, is admirably described; as we have stated above, his was the pioneer work in the operations which aim at leaking scars. To the operation of Elliot ten and a half pages are given; perhaps the importance of dissecting the flap into the cornea for a short distance is not sufficiently emphasized in so many words, though the fact that it is recommended is hinted at. Elliot's earlier form of incision for the flap is shown in a diagram, as well as his subsequent modification; it would have been a good thing, we think, if the actual site for the trephine hole had been indicated in this diagram; that shown in the next picture, over the honoured name of Dupuy-Dutemps, lies wholly in the sclera, and it is well known that if we habitually place it there we shall, in a very large proportion of our cases, not succeed in tapping the anterior chamber at all; this is the point on which Elliot has always insisted, and very rightly. It is refreshing to see that Terrien does not lay too much stress on the dangers of late infection in these cases; certainly it does occur sometimes, but its occasional occurrence must not be allowed to outweigh the manifest advantages obtained by these fistulous operations.

The section on operations for lacrymal obstruction contains accounts of the operations devised by Toti and by West from the rhinological side, while in an appendix is given an account of the performance of lumbar puncture.

We have said enough to show that the author has fully covered the ground of his subject; his book is one of the

very best that has appeared of late years on this subject, worthy to rank beside the works of Grimsdale and Brewerton in this country, of Czernak in Germany, and of Turk and Grout and Casey Wood in the United States. We have every confidence in recommending it.

CHEMICAL PATHOLOGY.

THAT a fourth edition of Professor H. GIDEON WELLS'S standard book on *Chemical Pathology*³ has become necessary within two and a half years of the third edition is evidence, if any were wanted, of the popularity and value of this exhaustive work of reference. Although much has been added, especially as regards vitamins and anaphylaxis, and hardly a page has escaped change, the size of this encyclopaedic volume is a little less than that of the previous edition. A feature of the treatise is the stimulation and help given to investigators by the copious references to existing sources of knowledge and the discussion of problems that demand further research. The style is condensed but extremely clear, and much of the detailed information is given in small print—for example, the account of the Abderhalden reaction, on which a new section was introduced in the third edition. In the chapter dealing with anaphylaxis or allergy reference is made to the view that this reaction can be produced by non-protein substances; this interpretation is not generally accepted, but it is possible for non-protein substances to combine with or so alter the proteins of an animal that they act as foreign proteins to that animal and thus cause sensitization; this is the explanation of the apparent anaphylactic reactions to iodine and arsenic compounds. With regard to the question whether closely allied proteins which can be shown by anaphylactic reactions to be specific can also be distinguished by chemical analysis, or whether they are dependent upon spatial relations of the amino-acid radicals, as suggested by Pick and supported by Dr. H. H. Dale in the recent Herter lectures (vide *BRITISH MEDICAL JOURNAL*, 1920, ii, 792), which came out after this work went to press, Professor Wells's experience indicates that usually, at least, proteins distinguishable by anaphylactic reactions also show readily recognizable chemical differences.

In the new section on vitamins, for which the alternative name of food hormones is suggested, an account is given of cases of xerophthalmia or keratomalacia observed by the author in the famine-stricken Rumanians, together with its prompt relief by cod-liver oil. War oedema, the author thinks, is due to a low protein and a high fluid intake. In discussing the difference of opinion about experimental scurvy in animals, it is suggested that it may be due to the fact that more than one condition has been described under the same name. Acidosis in renal disease, which is thought to account for nocturnal dyspnoea and to be due to the retention of acid phosphates in the blood, is lucidly described, and there is a summary of our knowledge of alkalosis, chiefly seen in tetany, whether of parathyroid origin or due to pyloric obstruction. The present edition therefore more than maintains the high reputation of the book as an authoritative work on this difficult and ever-changing branch of medical science.

PHYSICAL SIGNS IN LUNG DISEASES.

IN *The Clinical Examination of Diseases of the Lungs*, Drs. BROCKBANK and RAMSBOTTOM⁴ have published at the request of their students a clear and condensed account of the physical signs in pulmonary disease. The information is excellently arranged and is well suited to students commencing to clerk in the medical wards or out-patient clinics. An interesting point is made as to the danger of paracentesis abdominis in the presence of bronchitis; with considerable ascites the abdominal muscles, particularly the recti, are stretched, and when contracting in the act of coughing press on the contained fluid; but after removal of the ascitic effusion the stretched abdominal muscles are no longer able to contract sufficiently to exert pressure

² *Chemical Pathology*. Being a Discussion of General Pathology from the Standpoint of the Chemical Processes involved. By H. Gideon Wells, Ph.D., M.D., Professor of Pathology in the University of Chicago. Fourth edition, revised and reset. Philadelphia and London: W. B. Saunders Co., 1920. (Roy. 8vo, pp. 695, 35s. net.)

³ *The Clinical Examination of Diseases of the Lungs*. By E. M. Brockbank, M.D. (Vict.), F.R.C.P., and Albert Ramsbottom, M.D. (Vict.), F.R.C.P. London: H. K. Lewis and Co., 1921. (Cr. 8vo, pp. 96; 15 figures, 4s. 6d. net.)

⁴ *Surgery of the Eye and Its Adnexa (Chirurgie de l'œil et de ses annexes)*. By F. Terrien. Second edition (recast). Paris: Masson et Cie., 1921. (Roy. 8vo, pp. 636; 495 figures, Fr. 50 net.)

on the abdominal contents and to pull down the lower ribs, and consequently cannot assist the diaphragm and thoracic muscles in their expulsive efforts in coughing. As a result the patient cannot expectorate the bronchial secretion and may easily be drowned in his own sputum. Attention may also be called to the statement as to the way in which bronchial breathing may be imitated: the vocal organs are put into position for phonating the *ch* of the Scottish "leeh" or the syllable "ker," and the breath is then drawn in and out.

WOUND GANGRENE.

We entered upon the war with very little knowledge of the anaerobic infection of wounds, and from a combination of circumstances it was some time before the best methods of dealing with these deadly diseases were perfected. A book such as that of M. LARDENNOIS and J. BAUMEL⁵—the result of four years' experience and the handling of over 500 cases—could not in the nature of things make its appearance until the time was past when the knowledge that it contains would have been most useful. But from the medical side each generation is a sacrifice to those which follow it, and future peoples will profit from our own misfortunes. The danger is that books such as this will not to-day engage the attention which is their due. The immediate danger is past, and the words "gas gangrene" remind us vividly of a life which was too intensively lived to be pleasant in the retrospect. Yet this little book is most interesting—as any book must be which tells the story of the evolution of our knowledge of a disease from the day of ignorance and failure to that later day of victory.

M. Lardenois and Baumel have produced a valuable monograph, small and compact, yet embracing all the important aspects of the subject. The bacteriological evidence and the anatomical and physiological results of anaerobic bacterial invasions are clearly and concisely dealt with. Special stress is laid on the recognition of warning symptoms—"les signaux d'alarme." Six radiographs of gas-infected limbs are included, and give the uninitiated an excellent idea of muscle infiltration by gas-forming organisms. The authors believe in the preventive and curative value of polyvalent antisera, and hold that local surgical treatment should always be combined with and helped by that means. A very complete bibliography and an index are provided. Altogether, it is a book which we can thoroughly recommend. We may add that it has been *couronné* by the Academy of Medicine.

NOTES ON BOOKS.

In relation to so-called "psychic phenomena" there are two attitudes of mind, one receptive of the idea that such happenings are only to be explained by human forces unknown to and as yet unappreciated by our senses, the other sceptical and inclined to attribute the phenomena to illusions of the senses, as in the case of the tricks of the conjurer. A third attitude is, of course, possible: one of cold inquiry, willing to investigate, but indifferent to the results of the investigation. This attitude would be ideally scientific, but its existence may be doubted. The first attitude seems to have been that of Dr. CRAWFORD when carrying on his experiments with the "Goligher Circle."⁶ We confess to adopting the second. But we advocate investigation, even of spiritualistic phenomena, whenever proper conditions can be observed. Unfortunately, suitable conditions are very rarely allowed by mediums; and this, combined with the mental attitude of those who profess to have investigated, makes it difficult to frame an impartial opinion. Thus Dr. Crawford appears to have been convinced that mediums can throw out from their toes, feet, or legs a curious emanation which felt like a "breeze of cold, disagreeable, spore-like matter." The extremity of this "psychic red" "materializes" and is able to lift tables. By means of basins of moist clay Dr. Crawford got impressions of the materialized end of the psychic red. Many of these impressions looked as if they had been made by feet or boots. On many there was a stocking-like pattern; and the clay was often contaminated with cotton threads and

other debris. Moreover, the medium's boots and stockings were found after the experiment to be covered in places with clay. Dr. Crawford had tied up the medium in such a way that she could not get her feet within eighteen inches of the clay, and states that on some occasions he had locked up her feet in a box. Yet even under such conditions the clay was found on the feet of the medium. Dr. Crawford's mental attitude led him to the conviction that the medium threw out pseudopods of soft plasma which took the impression of her stockings, through which they passed and imprinted it on the clay; and that in process of withdrawal into the medium's toes the pseudopod left a trail of clay. Our mental attitude calls up visions of the performer tied up by the spectators, and afterwards extricating himself. However, though Dr. Crawford is dead, it is said that the Goligher family is still available. Further experiments might be undertaken by an expert observer unbiassed by any hypothesis of pseudopods or of "psychic matter."

The *Medical Register*⁷ for 1921, which has now been issued, shows a continuation of the gradual increase in the number of registered medical practitioners, the number being 44,761 in 1920, as compared with the adjusted total of 44,510 for 1919 and 43,926 in 1918. Of the total, 50.20 per cent. were registered in England, 31.34 per cent. in Scotland, and 14.19 in Ireland; 3.98 per cent. of the names appear in the Colonial list and 0.29 per cent. in the Foreign list. In 1920, according to the *Medical and Dental Students' Register, 1920*,⁸ 2,531 medical students were registered as such on commencing their studies, 1,099 in England, 910 in Scotland, and 522 in Wales. For the first time for three years more medical students have registered in England than in Scotland, but even now the number of students entering at Edinburgh University and Medical School is greater than that at all the London hospitals, colleges, and schools together. The *Dental Register*⁹ for 1921 shows that the number of dentists, 5,610, has increased from the previous year, 5,455, but the increase during the last eight years has been very slight. The new dental students, 560, are not quite so many as in the previous year, 612, but in each of these years the number has increased enormously as compared with the years during the war, and is almost double the number before the war.

*The Rat and How to Kill Him*¹⁰ is the title of an illustrated pamphlet by Mr. ALFRED MOORE, which gives particulars of the vast depredations caused by rats, and a summary of the methods of rat destruction. He is strongly opposed to the use of virus for killing rats, and he gives many useful hints on the preparation of rat poisons, traps, fumigation, and other methods. The text of the Rats and Mice (Destruction) Act, 1919, is included as an appendix. Mr. Moore urges his readers to become members or associates of the Vermin Repression Society, of which he is the honorary secretary.

⁷ *The Medical Register for 1921*. London: Published for the General Medical Council by Constable and Co., Ltd. 1921. (Sup. roy. 8vo, pp. lxxxiv+1252.)

⁸ *Medical and Dental Students' Register, 1920*. London: Published for the General Medical Council by Constable and Co., Ltd. 1921. (Med. 8vo, pp. 99.)

⁹ *The Dentists' Register*. London: Published for the General Medical Council by Constable and Co., Ltd. 1921. (Sup. roy. 8vo, pp. xxvii+139.)

¹⁰ London: J. Bale, Sons and Danielsson, Ltd. 1921. Price 9d. net.

APPLIANCES AND PREPARATIONS.

A Syringe for Treatment of the Posterior Urethra. Dr. M. W. BROWDY (London, W.) writes: In the treatment of chronic posterior urethritis or the sexual neuroses, one often wishes to instil a medicament into the posterior urethra, and Uitzmann's syringe is used for that purpose. All operators are aware of the difficulty of localizing the instillation to the spot desired, and unless one has considerable skill the fluid is either injected into the bladder or into the anterior urethra, with unsatisfactory results. The Holborn Surgical Instrument Co., Ltd., have made for me a solid ended catheter 8 in. in length, with a universal holder to fit an ordinary 20 m. Record syringe. Down the centre of the instrument passes a fine bore which opens into a hollow notch, one inch in length, placed on the convex side of the catheter curve. When the instrument is *in situ* the veru montanum projects into this concavity and so can be treated; or, on slightly withdrawing the instrument the remainder of the posterior urethra can be dealt with.

A SERIOUS outbreak of pneumonic plague is reported to have occurred recently at Vladivostock. Plague is also reported to be rife in Siberia, whence it is spreading westward, and has already reached Russia in Europe.

⁵ *Les infections gangréneuses des membres consécutives aux plaies de guerre*. By M. G. Lardenois and J. Baumel. Paris: Masson et Cie. 1920. (Demy 8vo, pp. 248; 26 figures. Fr.12 net.)

⁶ *The Psychic Structures at the Goligher Circle*. By W. J. Crawford, D.Sc. London: John M. Watkins; New York: E. P. Dutton and Co. 1921. (Demy 8vo, pp. 157; illustrated. 10s. 6d.)

British Medical Journal.

SATURDAY, MAY 14TH, 1921.

THE PREVENTION OF PUERPERAL INFECTION.

WHEN the Registrar-General's Report for England and Wales for 1919 was published we drew attention in a leading article¹ to the increased maternal mortality attributed to pregnancy and childbirth in that year. We deplored the fact that in spite of improved obstetric and ante-natal training of both medical students and pupil midwives, especially as regards the need for asepsis in midwifery practice and the danger of frequent vaginal examinations, and in spite also of the notification of puerperal fever to the M.O.H., and the better linking up of midwives, doctors, and lying-in hospitals, the puerperal death rate of mothers was greater than in any year since 1905. The Registrar-General stated that this increased mortality was "preponderantly due to septic disease." Thus, of the 3,204 deaths assigned to "pregnancy and childbirth," 1,208, or 37 per cent., were due to puerperal infection. In 1913 the percentage of deaths due to infection was 32, and this led Sir Arthur Newsholme to add the obvious but important words, "Such infection should be as rare in obstetrics as it has become in surgery."

The majority of the remainder of puerperal deaths are grouped under "other accidents of childbirth," and are recognized as being largely preventable if all pregnant women, especially primigravidae, were examined by competent obstetricians during pregnancy. Such conditions as contracted pelvis, pelvic and other tumours, toxic albuminuria, and mal-presentations, could be so dealt with, then or later, that maternal deaths would not occur from them. *Ante-partum* haemorrhages are almost the only "other accidents of childbirth" which, with our present knowledge, cannot be anticipated, but maternal mortality, even in these cases, could be reduced to a minimum if for every pregnant woman expert assistance, preferably in hospital, was in some way made available. These are agreed facts, and the required prophylactic measures are being slowly evolved, but they depend mainly upon organized facilities being provided, and in this the Ministry of Health must play a part through the local health authorities.

The prevention of puerperal infection is a wholly different matter, for puerperal septicaemia is almost entirely due to the faulty technique and unpreparedness often still present in midwifery practice, when the doctor, the nurse, or the midwife come into association with the woman during the few hours of her labour. It is therefore a personal and not a municipal or sanitary proposition. Many a woman would escape infection if the attendant only arrived as the child was passing over the perineum, so that no vaginal examination could have been made. The prevention of infection during labour would have saved over 1,200 deaths in England and Wales in 1919, and is more important, therefore, than the exercise of special skill. The absence of special skill in the use of forceps or in version may delay

the birth or cause the child to be stillborn, but the absence of asepsis, even in a small detail, may cause a mother's death within the next few days, or may lead to such morbid changes as will destroy all her potentialities of future motherhood.

Aseptic midwifery has eliminated the terrible hospital prevalence of puerperal fever; it was the chief cause of maternal death fifty years ago, when, for instance, in the York Road Lying-in Hospital one mother died in every thirty-two confinements between 1833 and 1860. Why, then, cannot the same success attend midwifery all over the country? The present mortality in England and Wales from puerperal infection outside hospitals is about two in 1,000 confinements every year.

We publish in the present issue (p. 693) a valuable and suggestive address by Dr. Blair Bell on the prevention and treatment of puerperal infections, in which he brings forward strong arguments in favour of strict asepsis in the conduct of every parturition, and urges that there should be no interference with the labour if it is possible to avoid it. There is no need or justification for interference in a normal physiological labour, but as interference may become necessary at any stage of labour, should something abnormal develop, asepsis is always necessary to prevent infection. Infective organisms are almost invariably conveyed into the vagina and uterus by the attendant's hands or instruments. If sterile rubber gloves are not used, or instruments are not efficiently sterilized, the patient may be infected by the attendant directly; but even if his hands and instruments are sterile, the attendant may carry infection into the uterus from the septic and pathogenic organisms always present around the entrance of the genital passage, if the skin has not been rendered temporarily sterile. Sometimes the patient has already been examined by the nurse, without aseptic precautions, before the doctor arrives. This is dangerous and unjustifiable, and should be absolutely forbidden.

Germs may be described as autogenetic if derived from the patient's own tissues, but the infection would not properly be called autogenetic if these germs are carried up to the placental wound by the attendant. Perineal and vulval lacerations may also be infected by the organisms of the patient's skin. This may be prevented by immediately and carefully closing all such lacerations with accurately placed sutures. Infections from lacerations usually lead to local cellulitis.

As regards the feasibility of conducting a normal labour without vaginal examination, it is a fact that if a woman has been examined during her pregnancy by the attending practitioner, he can find out everything else he wishes to know by abdominal palpation, except the progressive dilatation of the cervix and descent of the presenting part, and this information he can obtain by rectal examination, as Dr. Eardley Holland has suggested. Sterilized rubber gloves must be worn as a "point of honour" in all such examinations, and sterile overalls must be worn throughout the attendance. Too frequent use of forceps is condemned by all experts, and Dr. Blair Bell strongly urges that "the practice of using forceps indiscriminately, without medical need, to save the mother further pain, or to appease a husband's anxiety, or to save the time of the practitioner, should cease." In this view he is fully justified.

The main question to be decided is how far the practitioner or midwife should go in the preparation of the patient to safeguard her against infection. Should every parturient woman be prepared as if for

¹ BRITISH MEDICAL JOURNAL, March 5th, 1921, pp. 354-355.

an operation which may involve vulval, vaginal, and cervical lacerations and an intrauterine wound? Theoretically, this would entirely prevent infection, if effectively carried out, by an attendant who realizes his own responsibilities as the operator, and it is found easy to carry it out in hospital practice. Though rectal organisms do not infect a parturient woman unless through the contaminated hands of the attendant, the anal region must be regarded as a source of danger, and care should be taken to have the rectum previously emptied, as in a pelvic operation. The skin round both the anal and genital areas should be prepared precisely as if a pelvic operation were about to be performed, by a sitz bath in a weak antiseptic solution, and the application of a 2 per cent. iodine solution, or other usual antiseptic. To complete the preparation, in all cases where interference has become necessary, Dr. Bell says "no makeshift (as regards asepsis) must satisfy the practitioner," and he therefore succinctly says: "The vulva must be shaved," and later on says: "All this ritual is absolutely necessary." There should be no difficulty in doing this shaving, under anaesthesia, previous to the use of forceps or version, and in most cases it could be done early in labour without objection being raised, and without anaesthesia, previous to vaginal examinations, if these have become necessary, for it must be admitted that any interference with a labour, normal or abnormal, should be regarded as a surgical operation, as Mr. Victor Bonney has recently insisted. The more complete the aseptic ritual is the safer will be the labour, for it is probably true that the more casual or unpremeditated the "interference" such as the passage of a catheter, the more likely is it to be associated with an imperfect asepsis.

Putting aside, however, all controversial points, let the profession concentrate on the two methods now agreed upon as the most likely to prevent puerperal infection and mortality. These methods are not in dispute and have emerged from much experience and discussion of the subject. They may briefly be stated to be: (1) There should be no vaginal examination or other interference during labour unless absolutely unavoidable; and (2) there must be as complete an aseptic preparation of the patient, of the attendants, and of the obstetric paraphernalia, at every confinement, as would be appropriate to a pelvic operation. Cannot midwives, and practitioners who attend midwifery throughout the country, be persuaded to adopt these principles of prophylaxis in their entirety, and in every confinement, and so save the 1,000 lives of their countrywomen which are annually sacrificed by unguarded interference and imperfect asepsis?

It is of happy augury, as announced in our issue of March 19th, 1921, page 447, that in accordance with the will of the late Dr. Robert Thomas Nichols, the Royal Society of Medicine has been able to organize, in consultation with its Obstetric Section, a valuable triennial prize of £250 for the best contribution on "the discovery of the causes and the prevention of death in childbirth from septicaemia." This should stimulate research, which is needed as regards almost every detail of the problems of the causation, prevention, and treatment of puerperal septicaemia. Much may be expected also from the researches which all the new obstetric units, when they are established, will be able to undertake as regards the presence, vulnerability, and best method of dealing with the potentially infective organisms present in the birth area of a parturient woman.

PNEUMONIC COMPLICATIONS OF MEASLES AND INFLUENZA.

THE first and second fasciculi of vol. xx of the Johns Hopkins Hospital Reports¹ are devoted respectively to the pathology of the pneumonia in the United States Army Camps during the winter of 1917-18 and to the pathological anatomy of pneumonia associated with influenza. Both are written by W. G. MacCallum, Professor of Pathology in the Johns Hopkins University, and they provide a masterly account, with numerous admirable plates, of the morbid changes. These two articles deal with subjects much in need of accurate classification, and may with advantage be read in conjunction; the various forms of pulmonary inflammation are as far as possible correlated with different infective agents, but there is considerable overlapping due to mixed infections, and the success that has been attained is the result of much patient labour.

The first article contains the results of two Commissions appointed by the Surgeon-General of the United States Army to investigate the epidemics of pneumonia among the troops in America, and has already appeared as a monograph (No. 10, April 16th, 1919) of the Rockefeller Institute for Medical Research. The historical survey of epidemics of pneumonia since the sixteenth century refers to the occurrence of similar outbreaks of measles and pneumonia in the campaigns of 1812 and the civil war, and in museum specimens from the latter Professor MacCallum found the streptococcal bronchopneumonic lesions present in 1917-18. Although camp sanitation has made great strides since these old campaigns, preventive medicine was helpless against measles and pneumonia, which swept through the camps in America, especially in the Southern States, during 1917-18 just as in 1812. This epidemic was one of streptococcal bronchopneumonia, with measles as the most important disposing cause, but the bronchopneumonia subsequently arose independently of measles in individual cases when this secondary infection became sufficiently virulent. The pulmonary lesions varied considerably and there were several types of infection with various combinations, but analysis shows that there were two main forms. The first was due to the pneumococcus causing lobar pneumonia, but these cases were not more numerous than is usual at the time of year; and the second to *Streptococcus haemolyticus*, producing either what is termed interstitial bronchopneumonia or another type of lesion called for convenience lobular pneumonia. These two forms were not infrequently combined, and in sixteen out of forty-eight acute cases influenza bacilli were also found either in the bronchioles or occasionally in the alveoli of the lungs, but the condition was essentially the result of infection by the haemolytic streptococcus.

The account of the pathological anatomy of pneumonia associated with influenza in the autumn of 1918 and in January and February, 1920, is based on the examination of 46 cases. Although the character of the primary influenza was identical in all the camps, the secondary bacterial invaders varied; in one camp influenza bacilli were constantly present, whereas in another they were almost absent; the type of bacterial infection producing pneumonia thus differed with the place and depended on the local prevalence

¹ The Pathology of the Pneumonia in the United States Army Camps during the Winter of 1917-18. By W. G. MacCallum, M.D. Johns Hopkins Hospital Reports, vol. xx, Fasc. I, pp. 1-148, 53 plates. Baltimore: The Johns Hopkins Press, 1920. Pathological Anatomy of Pneumonia associated with Influenza. By W. G. MacCallum, M.D. Johns Hopkins Hospital Reports, vol. xx, Fasc. II, pp. 149-249, 23 plates. Baltimore: The Johns Hopkins Press, 1921.

or on the presence of carriers of some virulent organism, and therefore on a local epidemic such as one of streptococcus, staphylococcus, or the influenza bacillus. Influenza greatly lowers the patient's resistance, as is also shown by the accompanying leucopenia, and so favours secondary infection of the lungs by pathogenic micro-organisms.

Professor MacCallum believes that influenza is caused by an infective agent which differs from those as yet definitely recognized in that it is invisible, unstainable, ungrowable, and cannot be made to infect animals; it probably bears a general resemblance to the viruses of measles, scarlet fever and small-pox. Whether any of the morbid changes in the lungs or elsewhere can be ascribed solely to the action of influenza is unproven, but there is some evidence in favour of Goodpasture's view that great dilatation of the ductuli alveolares with a hyaline lining in a patch of pneumonia is of this nature. The lungs were found to show characteristic changes corresponding to the bacteria present: the lesions resulting from intense infection by the haemolytic streptococcus could easily be recognized, as could those due to the influenza bacillus, and probably also the rarer ones caused by staphylococci; the changes caused by the pneumococcus are practically the same as those in pneumonia at non-epidemic times.

The forms of pneumonia following epidemic influenza are divided into four groups: (1) Pneumonia with dilated ductuli alveolares and a hyaline lining, oedema and haemorrhage, the common feature being the peculiar hyaline lining of the ductules, which, as mentioned above, may possibly be due to the virus of influenza. This form of pneumonia is associated with various predominant bacteria, the pneumococcus, staphylococcus, streptococci, and Gram-negative cocci. (2) Cases terminating fatally, with great numbers of pneumococci in the lungs and elsewhere, and with diffuse pneumonic consolidation in which the peculiar changes in the ductules are absent or masked. (3) Cases in which a characteristic pulmonary lesion is the outcome of an overwhelming infection with the haemolytic streptococcus; the infection is much more intense and the morbid changes much more severe than in the streptococcal bronchopneumonia following measles—a difference perhaps meaning that whereas measles disposes to invasion by the haemolytic streptococcus, influenza annihilates the resistance of the individual so that his tissues act almost like an inert medium for the haemolytic streptococcus. The microscopic picture shows little cellular exudation or fibrin, but enormous oedema, necrosis of the alveolar walls and thick blood-stained fluid filling their cavities. (4) Cases with the influenza bacillus in pure culture or predominant show two types of morbid change. The first is acute peribronchial infiltration accompanied by extensive haemorrhage and oedema, so that the lungs may be more intensely haemorrhagic than in any other form. The second is seen in cases in which the less rapid course (nineteen days on an average, as compared with thirteen days in the previous category) leads to the production of hard nodular peribronchial interstitial infiltrations of the tissues and exudation into the alveoli and bronchi. This lesion has some resemblance to the interstitial bronchopneumonia following measles and due to the haemolytic streptococcus, and it should be noted that in a third of the influenzal cases the haemolytic streptococcus was also present. Professor MacCallum concludes that both of these organisms have, under proper conditions, the power of producing an interstitial bronchopneumonia, but that there are considerable differences between the resulting lesions.

ARTIFICIAL LIGHTING.

THERE are few of us who can realize what the town of a hundred years ago was like when the sun had set. The night was dark with a darkness made the more evident by the feeble flicker of oil lamps that did duty for the illumination of those days. Even our experience in recent years of the dimming of the street lamps during air raid times did not reproduce the experience of those days. Modern lighting has revolutionized the town; it is, indeed, one of the factors which have made great cities possible. Of all the external influences on physical, mental and moral well-being there is none greater than light. To dwellers in northern climes the discovery and development of electric light has been a great boon. Our long winters would be no longer the dread of light-loving Shakespeare. We can at will banish the close-enfolding darkness of the night by touching a button. Our streets we can wreath with glowing globes; dark alleys no longer give rise to lurking terrors, for where light enters darkness and evil flee. Our homes are bathed in an effulgence which can make the humblest house more desirable than the palace of the Tudors. The children scamper down passages, upstairs and into distant rooms, no longer fearful of the ghosts conjured up by the flicker of an oil lamp. We rise on the darkest, dreariest winter morning assured of the welcome of golden rays. The deepest fog of our cities is mitigated by them, and our evenings when toil is done are ours to the full both in places of concourse and in our homes, for there is light at our command. Truly the maker of light is a benefactor, whose name all men should delight to honour. A book on the influence of artificial light on civilization has now been written by Mr. Luckiesh, director of the research laboratory of the General Electric Company of New York.¹ In it he traces the development of lighting from the earliest times until to-day. It is a fascinating story, that grows more interesting as the present day is approached. Everyone ought to know enough about the physics of lighting to understand high pressure gas lighting, electric glow lamps, gas-filled lamps, the principles upon which depend half-watt lamps, the many forms of arc lamps, and the mercury vapour lamp. During the progress that has been made in the power and efficiency of the various methods of lighting there is room for improvement in the manner of their use. The necessity for care has been brought home by two papers recently read before the Society of Illuminating Engineers by Messrs. Stroud and Leachman.² They deal with street lighting and shop window illumination. Both are worthy of study. Wherever one goes, in streets, public buildings, and homes, there is found evidence of much ignorance or laziness in the usage of light—ignorance which results in much eye fatigue, and in much waste of valuable light and therefore of money. In many shop windows the lighting is so excessive and so badly arranged that the passer-by cannot see the goods for the glare. If shopkeepers mixed a little brains with their lighting they would learn that half the light well distributed by efficient reflectors would mean lower costs and more customers. Busy street corners, in normal times, are made confusing and dangerous by the glare of powerful exposed lights; pedestrians are worried, and vehicle drivers are wearied by these displays of selfish ignorance. Some of our theatres are intolerable by reason of excessive lighting; new lamps have been placed in old settings without thought. Churches have been made lighter by night than by day by the same reckless scattering of unscreened lamps. In domestic lighting it often happens that little

¹ *Artificial Light: Its Influence upon Civilization*. By M. Luckiesh. London: University of London Press, 1920. (Demy 8vo, pp. 366. 12s. 6d. net.)

² *The Use of Light as an Aid to Publicity, Shop Window and Spectacular Lighting*. By Captain E. Stroud. *Light as an Aid to Publicity: Illuminated Signs*. By E. C. Leachman. Papers read before the Society of Illuminating Engineers. February 24th, 1921.

thought is given to the use of the room when the lights are put in; so many points are arranged and the fittings are chosen at the shop or left to the sweet will of the purveyor. The appearance of Mr. Luckiesh's book and the papers of the Illuminating Engineering Society are welcome signs that better measures may be brought into use speedily.

FRIENDLY SOCIETY SUPPORT FOR HOSPITALS.

It will be recalled that the committee appointed by the Minister of Health on January 25th, with Viscount Cave as chairman, "to consider the present financial position of voluntary hospitals, and to make recommendations as to any action which should be taken to assist them," made an interim report in March.¹ The main object of that report was to deal with the pressing question whether the approved societies under the Insurance Acts should be asked to make contributions to voluntary hospitals out of the surplus funds in their hands. These societies at the quinquennial valuation are empowered to submit to the Minister of Health for his approval schemes for utilizing the disposable surplus in providing benefits during the next five years. The list of additional benefits authorized by the Insurance Acts and Regulations includes "the payment of the whole or any part of the cost of the maintenance and treatment of members in a hospital or convalescent home." Lord Cave's committee expressed the strong opinion that in the interests both of the hospitals and of the societies, the schemes to be approved should provide for the allocation of a substantial part of the disposable surplus towards the cost of the maintenance of members in hospitals. "We have reason to believe (added the committee) that some of the largest approved societies would be glad to see these proposals generally accepted, and that the hospitals would welcome such a result." The National Deposit Friendly Society, at a conference held this week at Southampton, decided, on the recommendation of its Benefits Committee, to allocate one-third of its surplus funds towards the cost of hospital treatment and nursing services for its members, the other two-thirds being devoted to increasing their sickness, maternity, and disablement benefits. In framing its scheme upon these lines the National Deposit Friendly Society has given a lead which it is to be hoped will be followed by the other large friendly societies. Section 21 of the National Insurance Act of 1911 runs as follows: "It shall be lawful for an approved society or Insurance Committee to grant such subscriptions or donations as it may think fit to hospitals, dispensaries, and other charitable institutions, or for the support of district nurses, and to appoint nurses for the purpose of visiting and nursing insured persons, and any sums so expended shall be treated as expenditure on such benefits under this part of this Act as may be prescribed." In its interim report Lord Cave's committee remarked that the power given to the approved societies by this section to subscribe to hospitals had been little used, doubtless owing to the anxiety of the managers that their resources should be sufficient to meet all claims; "but now that a surplus is in sight it seems probable that a different view will be taken." In the case of the National Deposit Friendly Society the available surplus, according to the Government valuation, exceeds £381,000. The total disposable surplus of all the approved societies is estimated at £7,000,000.

OPHTHALMOLOGICAL SOCIETY'S ANNUAL CONGRESS.

The ninth annual congress of the Ophthalmological Society of the United Kingdom was held at the house of the Royal Society of Medicine, on Thursday, Friday, and Saturday, May 5th, 6th, and 7th, 1921. The President, Mr. J. Herbert Fisher, was in the chair, and the attendance

was most satisfactory, a large number of the provincial members having braved the long and tiresome journeys of the present day in order to be present. The President, in opening the proceedings, welcomed the members in a few well-chosen words, and gave a short address on the personal equation in clinical ophthalmology; he also made a sympathetic allusion to the recent deaths of two of the original members of the society, Mr. Charles Higgins and Mr. Henry Edward Juler. The morning's papers were all purely technical in kind. Dr. Maitland Ramsay made a most important communication on a case of iridocyclitis associated with swelling of the parotid glands. Few cases of this nature have hitherto been recorded, but the society was fortunate in having in its *Transactions* for the year 1917 a similar case, reported by Dr. George Mackay of Edinburgh. Dr. Mackay supplied further notes of this case, and the subject was discussed by Dr. Hawthorne and others. The prevailing opinion was that the condition must be toxic in origin, but in the case now reported most careful general examination had failed to detect the cause. In the afternoon there was an interesting discussion on the abstruse subject of the psychology of vision in health and disease. The openers were Professor Spearman from the physical side, and Mr. J. Herbert Parsons, F.R.S., from the ophthalmological. Sir R. Armstrong-Jones said that blindness was comparatively rare in lunatics; deafness was far more common; he related the results of experiments made many years ago, in which he had investigated the reaction of lunatics to coloured environments. Dr. Kinnier Wilson dealt with the psychological peculiarities in some visual auras in cases of epilepsy, while Mr. Frank Juler spoke on amblyopia from disuse; he brought forward a series of twenty-two cases of traumatic cataract in children, tracing the visual results from the time of the injury to the present day. Dr. A. S. Percival also spoke. At 5 p.m. the West Hall was crowded to hear Mr. Treacher Collins deliver the Bowman Lecture in memory of the founder. He took as his subject, "Changes in the visual organs correlated with the adoption of arboreal life and the assumption of the erect posture." It was certainly one of the best Bowman Lectures that has been delivered. On Friday morning Mr. Worth and Mr. Ballantyne opened a discussion on a subject of perennial interest—the treatment of manifest concomitant squint. Very varied are the views held on the value of fusion training, the age at which operation is to be advised, and the type of operation which gives the best results. Most of the speakers outlined their own practice, and Mr. Bishop Harman gave an excellent summary, illustrated by pictures on the screen, of the reefing operation devised by himself. Messrs. Maddox, Harrison Butler, Mayou, Cruise, Brooksbank James, and Stack also spoke. In the afternoon the clinical meeting was held at St. Thomas's Hospital. The cases shown were well up to the average in number and variety. Colonel Herbert brought up some cases to show the results of his iris inclusion operation in cases of glaucoma, on which he read a paper in the evening, claiming that this operation in his hands had given good results and insisting on the safety of the eye from late infections afterwards. Dr. Maitland Ramsay showed Barraquer's instrument for the suction extraction of cataract, the operation which was performed on the late Empress Eugénie. The evening's papers were of the highest interest. Messrs. Goulden and Whiting read the notes and showed illustrations of a case of implantation cyst of the sclera following an operation for squint. Sir William Lister spoke on intra ocular epithelial cysts, and also read a paper on punctate deposits in the retina, a subject on which little has been known up to the present. Mr. Harrison Butler read a paper on the rational treatment of glaucoma, and outlined his own practice. On Saturday morning, after the usual business meeting, Sir Arnold Lawson communicated the notes of a rare case of orbital tumour, and showed slides of the growth. Mr. P. G. Doyne read a masterly paper on scotometry, dealing

¹ BRITISH MEDICAL JOURNAL, March 26th, 1921, p. 453.

with enlargement of the blind spot and causes of central and paracentral scotoma in cases of glaucoma, tobacco amblyopia, and high myopia. The other papers were of a purely technical nature.

THE RED CROSS.

A SPECIAL effort is being made this month to obtain recruits for the Red Cross. The experience of the war and what has happened since has convinced the moving spirits of the British Red Cross that it must be a militant body and that the League of Red Cross Societies is right in maintaining that it must be prepared to help in bringing succour to the victims of civil catastrophes and in the prevention of disease in peace. The Red Cross appeals now not only to the individual for money, but for his personal work and interest. He is asked to use his own home as a base of operations and to take an active part in the fight by spreading the gospel of health and preaching the crusade against disease. It is hoped to enlist the interest of young people and to build up a world conscience to which racial instincts shall be subservient. All this is admirable and seems to us correctly to indicate the sphere of work of the Red Cross in peace. The organization was founded with the view solely of giving help to the sick and wounded in war; to keep interest alive in peace it is only wise to provide some immediate object, and it is essential that policy in this respect shall be carefully considered. The recent International Red Cross Conference at Geneva decided to invite national Red Cross societies to draw up and transmit to the International Committee of the Red Cross accusations which they may have to make against any belligerent country in respect of any breaches of the Geneva Convention on land or sea during the late war. The International Committee was to transmit the accusations to a Special Commission, consisting of delegates selected by the Red Cross Committees of six neutral countries—Denmark, Norway, Sweden, The Netherlands, Switzerland and Spain—with one representative of the International Committee itself. It was proposed that this commission should hear the accusation and any defence offered by the Red Cross Committee of the accused country which might consult its Government, though the Special Commission would deal only with the national societies and not with governments. The proposal was due to the initiative of the delegates of the Canadian and Australian Red Cross Committees, but we are disposed to think that it ought to be dropped. As Mr. Danvers Power, deputy chairman of the Executive Committee of the British Red Cross Committee, has pointed out, it is not surprising that the German delegation to the conference at Geneva readily assented to the proposal, for it will allow that country still further to protract and obstruct inquiries. Charges of the sort ought to be tested by taking evidence with all legal formalities before they are put forward, as, in fact, has been done; they should be stated in proper legal form, forwarded officially, and adjudicated upon by a recognized legal tribunal. We agree with Mr. Danvers Power in expressing the hope that Red Cross societies of the allied countries will not "try their amateur hands at a game which has, up to the present, proved capable of providing much scope for foul play even when professional diplomatists are on the alert." If the Red Cross societies of the allied countries persevere with the plan proposed at Geneva they will shortly be confronted with interminable indictments, including in all probability false charges resting on the assertions of false witnesses, such as we were accustomed to during the war; to these witnesses the law of perjury will not apply, even if the means of testing their statements any longer exist. As he says, it will then be too late to decline jurisdiction, for in that case the answer would certainly be: "You do not appear,

now that you see the case against you, because you dare not; you deny us the justice your own conference offered; and thus ends the fable of German atrocities in the great war."

TYPHOID FEVER IN THE UNITED STATES.

In the *Journal of the American Medical Association* for March 26th is reviewed the typhoid fever mortality in the cities of the United States with a population of more than 100,000, of which there are now sixty-eight. More than a quarter of the population of the United States lives in these cities, and nearly one-sixth of the population lives in the cities with a population of more than 500,000. There are twelve cities in the country with a population of over 500,000, and ten of those had, in 1920, a typhoid death rate of less than 5 per 100,000, while in the two remaining cities, Detroit and Buffalo, the rate was 5.1. Detroit is stated to have lagged behind other northern cities in typhoid improvement during the last decade, but its present energetic health administration appears rapidly to be wiping out the arrears. An analysis of the typhoid cases in Buffalo during July, 1920 they numbered twenty—showed that in all of them the infection was contracted outside the city. From a survey of the whole record for 1920 it appears that typhoid is rapidly decreasing in the large cities of the United States. The striking drop in enteric mortality between 1918 and 1919 has been ascribed chiefly to the typhoid immunization introduced into the army camps in 1917-1918; a fact that seems to bear this out is that in a number of localities where, before 1919, the male typhoid rate in the group comprising the ages 20 to 30 was rather higher than the female rate, in 1919 this relation was reversed and the female rate was very much higher than the male rate. A similar reversal has been observed in France. The case of Louisville, which is included in the group comprising cities with a population of 200,000 to 300,000, shows the difficulties with which some public health authorities in the United States have had to cope. This city has achieved the lowest typhoid rate in its history, and one which compares favourably with other cities without its climatic and racial difficulties. Constant vigilance has to be maintained in Louisville against the use of water from the Ohio River and other polluted sources, and the Department of Health has had to overcome what is in the United States a familiar opposition to the closing of private wells in thickly settled districts. Well water may be cool and palatable, but these advantages, it is pointed out, do not counterbalance the existence of dangerous contamination. In the reports of typhoid in various cities the relative frequency of small outbreaks attributable to drinking the contaminated waters of rivers, small streams, and springs in public parks—often sources so obviously and badly contaminated that only the very young or very ignorant would think of using them—shows that education is necessary to prevent infection. It is the detailed, painstaking, and difficult work of the departments of public health in, for instance, the closing of polluted wells, the enforcement of sewer connexions, and the tracking of typhoid carriers, that is steadily cutting down the typhoid rates in North American cities.

"THE JOURNAL OF OBSTETRICS AND GYNAECOLOGY OF THE BRITISH EMPIRE."

The *Journal of Obstetrics and Gynaecology of the British Empire* was one of the many activities which, having no direct bearing upon the primary object of bringing hostilities to a victorious conclusion, was crushed out of existence by the war. First published in January, 1902, with the intention, which it afterwards so admirably fulfilled, of being "a complete and impartial record of British work, an exponent of obstetrical and gynaecological practice, and a summary of contemporary thought and achievement in obstetrics and gynaecology throughout the world," it struggled on after the outbreak of war until

August, 1915, when its publication was suspended. After the advent of peace it was felt that a journal which is recognized to have done so much excellent work for the advancement of that branch of medical science with which it dealt should not be allowed to die, and it is now being revived. The company which established, and is now re-establishing, the *Journal*, is entirely composed of medical men and women, and its purpose has not been to earn dividends but solely to advance the science of obstetrics and gynaecology. Since first it was formed a new generation of obstetricians and gynaecologists has arisen, to whom the older generation now look to shoulder their due share of the responsibility. Dr. Russell Andrews, Dr. T. W. Eden, Professor Thomas Wilson and Dr. Blair Bell have been elected directors of the company, and the original chairman, Sir Francis Champneys, has accepted the cordial invitation he received to retain that office. The editor is Dr. Comyns Berkeley, who is assisted by Dr. Eardley Holland, and they must be congratulated on the appearance and the contents of their first number, which is appearing this week. The *Journal* is to be published quarterly by Messrs. Sherratt and Hughes, 34, Cross Street, Manchester, at an annual subscription of two guineas, post free.

THE RIVIERA IN SUMMER.

A FEW weeks ago we published an inquiry asking for a place within easy reach of the Riviera which would be suitable for a case of chronic pulmonary tuberculosis during the summer. The matter is of some general interest, for the belief usual in this country is that the whole of the Riviera district is too hot in summer for comfort. The inquiry has attracted the attention of a correspondent well acquainted with the Riviera, who writes to express the opinion that it should be easy for a patient with limited tuberculosis to pass the summer and autumn healthfully and enjoyably on, or practically on, the Riviera. "The department of which Nice is the principal town," he continues, "is not called Alpes Maritimes without good reason. A glance at an elevation map of Western Europe will show that the mountains bordering the sea from Nice to the Italian frontier are continuous with the Swiss Alps. Anyhow they are true mountains—running up in many cases to 7,000 or 8,000 ft. Throughout there are villages with inns, and I can imagine a fairly good walker spending many months wandering among them. They are old villages each with a history of mediaeval greatness behind it. There are also several places which definitely cater for summer visitors and which lie at heights varying from 1,500 to 5,000 ft.—Peiri-Cava, St. Martin Vesubie, and Vence are three examples. All these are within twenty to thirty miles of Nice and very easy of access by train or other means of locomotion." The same correspondent touches upon a complaint that the main roads through some of the Riviera maritime resorts have been very dusty this spring. "Any road," he says, "subject to much motor traffic in more or less summerlike weather is liable to be dusty, but probably many small Riviera health resorts have been less active in the matter of public work these last two years than previous to 1914. This is very natural; for five years they were deserts as far as money-bringing visitors go, and municipal chests are still rather empty. Moreover, labour power is at a very low ebb. The loss of France in the matter of trained workmen was enormous, and, though many arrive from Italy, they go north to the devastated areas where years and years of absolutely necessary work has still to be performed."

MEDICAL WORK IN KASHMIR.

THE Kashmir Medical Mission, carried on under the auspices of the Church Missionary Society, is an institution which, as is shown once more by its report for 1920, does excellent work and is deserving of an increase in the public support on which it is dependent. During the

year 874 major operations and 3,596 minor operations were performed, with a total of twenty-one deaths; including medical patients, 1,793 in-patients were treated, and there were 14,882 new out-patients, with a total of 34,815 attendances. The medical report states that tuberculosis appears to be increasing in Kashmir, and that sometimes quite one-third of the cases in the hospital were surgical tuberculosis. Abdominal cases come to the hospital sooner than they used to, a sign of confidence in the surgical staff. A difficulty experienced is the enormous number of septic cases admitted to the wards, but the lessons learned from war experience in similar cases has proved useful. The report includes an account of the work of the Leper Hospital, which is supported by the State of Kashmir, and of which Dr. Ernest Neve, of the Mission Hospital, is honorary superintendent. There were 208 patients in the hospital, and eight deaths occurred during the year. The gynecardate and morrhuate treatment of leprosy had a prolonged trial, but many of the patients were too advanced to offer a fair chance for any form of treatment. A separate home for leper children, of whom there were more than twenty in the hospital, is being organized. The question of the compulsory segregation of lepers (writes Dr. Neve) is one which ought to be faced. At present lepers are free to roam the country, and they may engage in occupations entailing the handling of food. Leprous milkmen are not unknown. The suppression of the disease can best be encompassed by the withdrawal of lepers from the midst of the community, and, if impossible to prevent their marrying, their offspring should at least be separated before they contract the disease, for it is not hereditary.

LAUNDRY HYGIENE.

FROM the standpoint of the hygiene and welfare of workers the laundry business as a whole leaves much to be desired. It is satisfactory to know, however, that some steps are already being taken in the right direction. Thus the Savoy Hotel Laundry, which was established a few months ago in new buildings off the Clapham Road, is an example of what can be done to better the conditions of laundry workers during their hours of employment. Those who are at all familiar with steam laundries of the old type, will be surprised to find how airy and sweet-smelling such a factory can be made, and how happy and wholesome-looking the girls, by careful attention to the details of lighting, ventilation, and sanitation, and by due regard to the human side of the industry. Care for the physical well-being of the workers is shown in the drying lockers and other features of the cloak-room, and in the arrangements of the rest-room. Before being engaged each employee is physically inspected by the medical officer, and is examined by him every week, while a trained nurse is always at hand in a room fitted up for first aid. A garden with roses, fruit trees, and ponds separates the laundry from the welfare department. Meals are served from a well equipped canteen, and the large mess-room, which has a polished floor, is meant to be used also for dancing and other social entertainments. Altogether, the welfare arrangements are in keeping with the very modern type of machinery and appliances installed in the laundry, and with the organization of sorting, packing and transport. The value of brightness, cleanliness, and fresh air, is shown in the healthy appearance of the workers.

THE OBSTETRICAL UNIT AT THE ROYAL FREE HOSPITAL.

THE formal ceremony of opening the Unit of Obstetrics and Gynaecology at the Royal Free Hospital, London, was performed on Wednesday afternoon, May 11th, by Her Majesty the Queen, who took this opportunity of expressing in a practical form her sympathy with the work of women for other women. During the Queen's visit there was a brief dedication service in several of the

wards, and although the unit is not yet fully occupied, the Queen saw part of it in normal working order. Among those presented to Her Majesty were Professor Louise McLroy, M.D., who has charge of the unit, and Miss Cox-Davis, matron of the hospital. The section of the hospital which composes the unit was occupied during the war by military patients and now consists of 63 beds—38 of them set aside for maternity cases and 25 for diseases of women, including the accommodation in the Marlborough Maternity Section in Endsleigh Street. The staff, in addition to Professor McLroy and her assistants, Dr. Gertrude Dearnley and Dr. Charlotte Houlton, includes 6 sisters and 25 nurses, and the wards contain only 12 beds each, arranged in bays of 4 beds, thus avoiding the depressing appearance and the publicity of the long rows of beds in more old-fashioned wards.

The subject of the annual oration to be delivered before the Medical Society of London by Lord Dawson of Penn on Monday, May 23rd, at 9 p.m., is "The colon and colitis." A *conversazione* will follow the oration.

The next session of the General Medical Council will commence at 2 p.m. on Tuesday, May 24th, when the President, Sir Donald MacAlister, K.C.B., M.D., will take the chair and give an address. The Council will continue to sit from day to day until the termination of its business.

Medical Notes in Parliament.

[FROM OUR PARLIAMENTARY CORRESPONDENT.]

Scottish Universities Bill.

MR. W. GRAHAM asked whether the introduction of a Scottish Universities Bill was contemplated, and whether, having regard to the great changes which had taken place in Scottish universities since the Act of 1889 was passed, and the importance of bringing their constitution and internal organization into line with present-day needs, and with the work of outside bodies in Scotland, such as local education authorities, technical colleges, and others, the Secretary for Scotland would be prepared to appoint a commission or committee to consider fully the working of the present university system in Scotland and to recommend the necessary changes. Mr. Munro said he was considering the possibility of introducing a bill of limited scope this session. He would keep in mind the suggestion made in the last part of the question.

War Enlistments and Casualties: The Gross Figures Analysed.

At the instance of Major Hamilton, on May 5th, returns were given showing the total number of enlistments (approximately) from within the British Empire for the Great War and the number of deaths and other casualties, the figures embracing not only the Armies, but the Mercantile Marine. The following is a summary of the table:

Country.	(A) Enlistments. All Ranks.	(B) Deaths from all Causes.	Wounded.	Prisoners.	Total Casualties.
Great Britain and Ireland	6,211,427	744,702	1,695,262	176,505	2,614,269
Canada	683,170	56,625	149,732	3,754	210,111
Australia	413,453	59,330	152,171	4,084	215,585
New Zealand	227,325	16,136	40,729	502	57,367
South Africa	136,373	8,852	15,153	1,718	25,703
Newfoundland	9,869				
Other Colonies	135,337				
Total Dominions and Colonies	1,605,527	140,923	357,785	10,058	508,766
India... ..	1,679,416	61,398	70,859	11,070	143,327
Total	9,496,370	946,023	2,121,906	197,433	3,266,362

(A) Includes military forces serving on outbreak of war.
 (B) Includes 14,472 merchant seamen and 1,099 fishermen.
 NOTE.—The figures given in this return include naval casualties between August 4th, 1914, and November 11th, 1918, and military casualties during the period August 4th, 1914, to April 13th, 1920.

The statistics of other countries give the following totals: France: Deaths from all causes, 1,385,300; wounded, no record. Belgium: Deaths, 58,172; wounded, 44,686. Italy: Deaths, 460,000; wounded, 947,000. Portugal: Deaths, 7,222; wounded, 15,751. Rumania: Deaths, 335,706; wounded, no record. Serbia: Deaths, 127,555; wounded, 133,148. Greece: Deaths, 5,000; wounded, 21,000. United States of America: Deaths, 115,660; wounded, 205,690. Germany: Deaths, 2,050,416; wounded, 4,202,028. Austria and Hungary: Deaths, 1,200,000; wounded, 3,620,000. Bulgaria: Deaths, 101,224; wounded, 152,400. Turkey: Deaths, 300,000; wounded, 870,000. The figures as to Bulgaria are considered an under-estimate, many archives having been lost. The figures as to other countries are approximate.

The Dentists Bill.

The Dentists Bill was introduced on May 9th by Sir Alfred Mond, and the text has now been printed. It consists of 17 clauses with schedules, and the measure is to apply to Scotland and Ireland as well as to England and Wales. The explanatory memorandum is as follows:

This bill gives effect to the recommendations contained in the report of the Departmental Committee on the Dentists Act, 1878 (1919, Cd. 35), and is identical with the bill which was introduced at the end of last session, except that the opportunity has been taken of making a few alterations of minor importance for the purpose of meeting criticisms on the former bill, and a few other alterations of a purely drafting character.

The bill provides for the establishment of a Dental Board, consisting partly of dentists and partly of medical practitioners, together with a non-professional element. The first Board is to be entirely nominated, but in succeeding Boards six out of the thirteen members will be elected by and from the dentists on the Register.

Clause 1 which will take effect not earlier than one year or later than three years from the commencement of the Act) prohibits the practice of dentistry by unregistered dentists.

Existing unregistered dentists are given the right of admission to the Register, subject to evidence of good character, if they satisfy the Board that they have for five out of the seven years immediately preceding the commencement of the Act been engaged in the practice of dentistry as their principal means of livelihood. Existing unregistered dentists who have been in practice for less than five years will be required to pass an examination before being admitted to the Register. The Board are given a dispensing power to deal with cases of persons who cannot meet the requirements of the bill by reason of military service.

Special provisions are included to deal with limited companies carrying on the business of dentistry. Existing rights are safeguarded, but in future all the directors and managers of such companies and the operating staff employed by them will be required to be registered dentists.

The powers of the General Medical Council, so far as they relate to the maintenance of the *Dentists' Register*, will be transferred to the Dental Board, but any regulations made by that Board under the bill must be approved by the General Medical Council and the Privy Council.

Dangerous Drugs Act.—In answer to Mr. Gilbert, on May 4th, Mr. Shortt said that the Committee on the regulations under the Dangerous Drugs Act, 1920, had nearly completed its inquiry, and he hoped to have their report shortly. The report would be published.

Indian Medical Service.—Major Glyn asked, on May 4th, what was the present total establishment of the Indian Medical Service; what proportion of the officers in this service were British-born, or natives of India, in the years 1910, 1914, 1918, and 1921; what steps were being taken to safeguard the position of British-born officers who joined before the war; what steps were being taken, if any, to encourage British-born candidates to enter the Indian Medical Service, and what was the proportion of candidates to enter the service, British and Indian, in 1910, 1914, 1918, and 1920. Mr. Montagu replied that the number of officers holding permanent positions in the Indian Medical Service on January 1st, 1921, was 767, and gave the following table of the number of permanent officers in the Indian Medical Service in the years inquired about:

	British-born.	Indians.	Total.
1910	694	57	731
1914	722	48	770
1918	712	71	783
1921	638	129	767

The distribution as between British-born officers and Indians had been arrived at after an examination of the names in the Army List, and must therefore be regarded as only approximately correct. He was not sure that he understood what was meant by that part of the question regarding British-born officers who joined the service before the war. The position of such officers was in no way jeopardized by the admission of officers, European or Indian, during the war. Every effort was being made to fill up existing vacancies available for Europeans and the conditions as regards pay, leave and pension had recently been considerably improved. It was advised, however, in view of the great shortage of medical men caused by the war, that it would be a year before the medical schools of this country would be in a position to turn out qualified men of

the standard required for the service in anything like the normal numbers. The candidates entering the service in the years inquired about were as under:

	Europeans.	Indians.	Total.
1910 (examinations) ...	22	6	28
1914 (examinations) ...	18	15	33
1918 (selection) ...	9	9	18
1920 (selection) ...	23	52	75

The Value of Treatment for Venereal Disease.—Mr. Waterson asked, on May 4th, whether the Minister of Health could produce any evidence to show to what extent cures were being effected as a consequence of the large expenditure of public money which was taking place in connexion with the diagnosis and treatment of venereal diseases; and, if so, whether he would arrange for such evidence to appear in the annual reports of his department. Sir A. Mond replied that the value of the work done at venereal disease centres could not be measured solely on the basis of the proportion of cures effected. He was advised that in the case of these diseases prolonged treatment followed by a period of observation was frequently necessary before a cure could be pronounced, and in some cases it was difficult to arrive at a conclusion as to cure. There were, however, many patients who, though they failed to continue treatment or to remain under observation until a cure could be pronounced, were nevertheless rendered non-infective before attendance at the clinic ceased. The system of clinics had not been long in operation. The results were under careful observation, and the report of the Chief Medical Officer of the Ministry for this year would contain a statement on the subject.

The Forthcoming Census.—Mr. Rose asked the Minister of Health, on May 5th, if he would take measures to secure the immediate compilation of an approximate occupational list as soon as the forthcoming census was taken, in order that the division of the population between occupied and unoccupied persons, and the allocation of the occupied population amongst the industries might be known. Sir A. Mond replied that special attention had already been paid to this subject in the census preparation. A full list and classification, both occupational and industrial, had been compiled on the best advice obtainable, and it was hoped that the steps taken would result in occupational and industrial statistics of great value being made available from the returns.

Medical Students in the Defence Force.—Mr. Briant asked, on May 10th, whether, seeing that many of the members of the Defence Corps who were being retained with no special duties to perform had left their medical and other studies to meet a national emergency, consideration for leave would be given on the undertaking that those to whom it was granted would immediately rejoin if their services were required. Sir Robert Saunders replied that instructions had been given to officers commanding units to grant leave up to 10 per cent. per unit at one time, with preference to teachers, students and others undergoing training, and especially for those who were preparing for examinations.

Medical Boards.—Lieut.-Colonel Lowther asked, on May 5th, how many members on the pensions medical boards were panel practitioners; what hours they were employed on these boards, and if it was in the interests of either the pensioners or the insured persons that these medical men should be so employed. Mr. Macpherson replied that he had no information such as would enable him to answer the first part of the question. He could state, however, that medical boards were constituted from a panel of 4,462 members, with the average weekly attendance of less than three hours for each member. He did not know that it would be either practicable or desirable to confine the selection of personnel of medical boards to doctors who had no panel practice.

More Pensions Appeal Tribunals.—Mr. Hnrd, on May 5th, asked whether the Minister of Pensions was aware that from one district alone of Somerset there were eight cases which had been awaiting hearing for periods up to eight months by the pensions appeal tribunals, and inquired what steps were being taken to expedite matters. Captain H. D. King (for the Lord Chancellor) said that twelve courts were at present sitting and five additional pensions appeal tribunals would begin to sit this month and others were being formed. The average interval between date of receiving appeal and its hearing was now ten weeks. In Somersetshire all appeals received up to the beginning of February last had been dealt with or would receive attention in the next fortnight. In answer to another question by Colonel Newman, Captain King said that there were approximately 9,200 cases outstanding and 50 cases a week were listed for bearing in each court. It was hoped to be able at an early date to deal with at least a thousand cases a week. Mr. Parker, in answer to Viscountess Astor, said that in cases where there was sufficient medical support to the appeal recoverable advantages might be authorized under certain defined conditions, pending decision by the tribunal.

Ex-Service Men in Mental Hospitals.—In answer to Mr. W. R. Smith, on May 6th, Mr. Macpherson said that in cases where the disability of ex-service men detained in mental hospitals was due to, or aggravated by, military service, pension was suspended during treatment and the usual allowances were

paid without deductions to the man and his family. The men were treated as service patients and the cost of their maintenance was paid by the Ministry of Pensions. If, however, the insanity was neither due to, nor aggravated by, service, nor formed part of the invaliding disability, and the man was drawing a pension in respect of a different disability, such pension might be appropriated by the guardians towards the cost of his maintenance in the institution. In such cases, however, the guardians concerned were invited to waive their claim to the pension in favour of the pensioner's wife.

Unemployment and Sickness Benefit.—Sir A. Mond, on the request of Sir Walter de Frece, on May 5th explained the position of unemployed insured persons in regard to sick benefit. During periods of unemployment insured persons fell into arrears in respect of their health insurance contributions. There was, however, an allowance of four weeks of unemployment in any year before any penalty was imposed in the form of reduction of sickness benefit, and even if the arrears exceeded this amount no reduction in sickness benefit could take place until the following year, and this reduction could be avoided by the payment of a comparatively trifling sum in the autumn preceding. Although the scheme of unemployment insurance differed materially from that of health insurance, it was not the case (as Sir Walter de Frece had suggested) that an insured person was credited with a contribution for unemployment insurance in respect of any week for which he received sickness benefit.

Bellahouston Hospital.—Mr. Neil Maclean asked the Minister of Pensions, on May 5th, whether the majority of the Local War Pensions Committee and Joint Disablement Committee had resigned as a protest against the manner in which Bellahouston Hospital was being managed, and if the Minister of Pensions had received the report called for. Mr. Parker (for Mr. Macpherson) said that reports had been received from regional officers. The information lent no support to the charges made against the hospital authorities, and the allegations of harsh and unsympathetic treatment of ex-service men appeared to be without foundation. In view, however, of the considerable local feeling, the Minister of Pensions proposed to hold a local inquiry, the nature of which would be determined as early as possible.

Dundrum Asylum Staff.—The Attorney-General for Ireland, on a question by Mr. Griffiths, on May 5th, whether the staff of the asylum at Dundrum, co. Dublin, had yet been put on the same conditions of service as the staff at Broadmoor Asylum, said that some points at issue had not yet been settled, but it was hoped that this would be done at a very early date; the staff were being paid the full bonus under the Whitley Council scheme.

Small-pox and Vaccination.—Sir A. Mond on May 4th said, in reply to an inquiry by Mr. Bromfield, that he had no authority to require that public vaccination records should be searched for evidence of vaccination in cases recorded as doubtful in respect of vaccination.

Milk Prices.—Mr. Cautley asked, on May 4th, whether the Minister of Agriculture would consult the Law Officers of the Crown as to the possibility of bringing before a Profiteering Committee the question whether 8d. was a reasonable charge for a retailer to make for a quart of milk which had cost him only 3½d. Sir W. Mitchell Thomson said that any retail purchaser of milk could bring this question before a Profiteering Act local committee by lodging a complaint. Mr. Cautley asked whether the matter was not of such great importance that the Minister of Food, or some other Minister, should institute these proceedings. Mr. Ratcliffe inquired whether it was not a fact that in the United States the Government were taking criminal proceedings against a great food combine for practices similar to this. The Speaker advised that notice be given of the question.

VENEREAL DISEASES IN CROWN COLONIES AND SEAPORTS ABROAD.

LAST autumn the National Council for Combating Venereal Diseases, with the co-operation of the Ministry of Health, and under the direct supervision of the Colonial Office, sent out three commissions, each consisting of an educational and a medical member, to investigate the prevalence of venereal diseases in the Crown colonies and seaports abroad, and to initiate or advise upon such local or imperial measures as might be necessary to reduce the incidence. One commission went to the Mediterranean, another to the West Indies, and a third to the Far East. In each case the subject was approached from a threefold point of view—that of the European residents, that of the native residents, and that of the members of the mercantile marine. Several of the commissioners made reports to a conference held at Caxton Hall on May 10th, which was presided over by Colonel Lord GORELL, who said that one thing which the work of the commissions had illustrated was that every part of the world must be inter-related in dealing with these diseases.

Mr. L. S. AMERY, M.P., Financial Secretary to the Admiralty, said that British trusteeship for the small nations under the Government of the Crown was not fulfilled merely by giving them honest government and assuming their financial responsibilities: they must be safeguarded as far as possible from the health point of view. His own interest in this problem was aroused during a visit to Uganda, one of the most highly advanced of African countries, into which had been brought sleeping sickness by the porters accompanying successive European expeditions from the Congo, and also syphilis by the Indian labourers engaged upon the construction of the Uganda railway, and the traders who followed in their wake. In these African protectorates very genuine efforts had been made to cope with venereal diseases, but the small and scattered British dependencies all over the world, often out of touch with the general progress of scientific thought, raised a more difficult problem. He welcomed the Council's policy of sending out these small commissions to awaken interest both among the official and non-official classes, and he believed their reports would be the first step towards practical reforms.

Dr. F. J. H. COUTTS, of the Ministry of Health, expressed the regret of Lord Onslow, the Parliamentary Secretary, at his inability to be present. The Ministry was quite sure that the effect of these travelling commissions would be to stimulate interest in venereal disease problems in the Empire and to encourage the development of schemes of treatment. From the commencement of the scheme for treating venereal diseases the Ministry had been strongly impressed with the need for giving every facility to seamen for treatment in the various home ports, and the local authorities had most zealously seconded its efforts. But the Ministry also realized that this was an international question, and had instructed the British representative in the Office Internationale d'Hygiène to bring before the representatives of other Governments the importance of an international arrangement. This had received very sympathetic consideration, and a draft agreement had been drawn up, providing that any sailor could get free treatment in any port, and to this agreement it was hoped all countries with seaports would subscribe. International machinery was slow to get into operation, and the matter was complicated by the fact that international agreements in public health would shortly be transferred from the Office Internationale to the Health Section of the League of Nations, but at the sitting of the Office Internationale, which had just concluded, the British representative had been instructed to obtain information as to the facilities already available.

Several commissioners then gave brief accounts of their tour. Mr. KENNETH WALKER (Medical Commissioner to the Mediterranean) said that the position in Gibraltar and Malta was very like what it was in England before the special effort of recent years. There were facilities for in-patient treatment, but the sailor who accepted them was likely to lose his ship. What was needed was a clinic where the sailor could receive treatment while in port, and carry on with his ship to the next port, where treatment might be continued. Dr. WINIFRID CULLIS (Educational Commissioner) dwelt upon the need for the provision of adequate recreational facilities at both Gibraltar and Malta, and, at Gibraltar particularly, for really good housing and sleeping accommodation.

Dr. LETITIA FAIRFIELD (Educational Commissioner to the West Indies) said that she and the Medical Commissioner (Dr. A. F. Wright) had been impressed with the value of the work done by the Salvation Army in the West Indies in promoting social diversions for the seamen. One urgent need was an amendment of the Merchant Shipping Act so as to remove all disabilities and penalties attached to the declaration of venereal disease by the sailor; at present these disabilities deterred a man from going for treatment. Another necessary reform was to prevent women from visiting ships at the various ports. Both syphilis and gonorrhoea in the West Indies were free from some of their more dramatic and striking effects, but the percentage of infection was admittedly serious. In one of the largest islands 40 per cent. of the patients in the public infirmaries were suffering from one form or other of venereal disease. Nearly 80 per cent. of the rejections for the British West Indies Regiment were on this account, and in that regiment 25 per cent. of the recruits became casualties from this cause during training. One found pathetic evidence of failure to realize what was meant by preventive medicine generally, apart from the venereal question. In British Guiana it was discovered that 50 per cent. of the school children harboured the malarial parasite, and the only recommendation of one of the inspectors

was that as this condition had a detrimental effect upon the school child it would be wise to modify the regulations for compulsory school attendance! The campaign against venereal diseases could be only a part of the general health campaign in the West Indies.

Mrs. NEVILLE ROLFE (Educational Commissioner to the Far East) said that the four ports which were visited by herself and the Medical Commissioner (Dr. Rupert Hallam) were Shanghai, Hong Kong, Singapore, and Colombo. At Shanghai a site was chosen for a clinic for seafarers, leaflets had been drawn up to be given to every incoming sailor telling him where he could get free treatment, and the authorities had promised that the surplus on next year's budget should be earmarked for this campaign. A specialist had been sent for from Europe, and immediately on his arrival the clinic would be started. In Hong Kong, where public health conditions were disgraceful, reform was a slower matter, but the Commission was able so to organize Chinese and British opinion in the colony that the authorities were at last convinced that in carrying out the recommendations of the Commission they would be falling in with popular sentiment. In Singapore the principle of free treatment facilities had been accepted by the Governor, who had agreed that the problem should also be considered for the Federated Malay States. In this port the president of the branch of the Society for the Prevention of Venereal Disease was also joint honorary secretary of the branch of their own National Council; the special point of difference which had arisen here simply did not exist when dealing with an illiterate native population. Colombo was the cleanest port visited and compared very favourably with any English port; at Colombo the women were denied access to the ships. It had been the aim at every port to form a welfare association for the provision of recreational facilities for the mercantile marine.

Lord GORELL said that this was not only an international but an imperial problem, and it might be possible to summon a conference of medical officers from all parts of the Empire to consider the question as a whole. The council would see to it that the recommendations of the Commissions, now with the Colonial Office, did not lie fallow. Mr. D. BRAMAH, of the Seafarers' Joint Council, expressed the indebtedness of seafarers to the National Council; and Mr. GRINDLE, of the Colonial Office, thanked the commissioners, and said that their recommendations would be most carefully considered. A letter was also read by the Hon. E. F. L. WOOD, Parliamentary Under-Secretary for the Colonies, congratulating the commissions on their work and on the wisdom and thoroughness of their recommendations.

PRESENTATION TO DR. J. A. MACDONALD.

THE following further subscriptions have been received from April 5th to May 7th, 1921, in response to the appeal published in the JOURNAL of July 24th, 1920 (p. 129), towards a presentation to Dr. J. A. Macdonald on the occasion of his retirement from the office of Chairman of Council of the British Medical Association which he had held for ten years. Subscriptions of any amount not exceeding five guineas should be made payable to "The Macdonald Presentation," and sent to the Medical Secretary, British Medical Association, 429, Strand, London, W.C.2.

SIXTEENTH LIST OF SUBSCRIBERS.

	£	s.	d.		£	s.	d.
Brought forward ...	933	17	0	Rogers, Dr. J. S. Y., D.S.O., Dundee ...	1	1	0
Ryall, Sir Charles, C.B.E., London ...	5	5	0	Millu, Dr. G. H. S., Dundee ...	1	1	0
Per Dr. Melvin (Hou. Sec. Rochdale Division):				Rankin, Dr. G., M.C., Dundee ...	1	1	0
Rodley, Dr. J., Rochdale ...	1	1	0	Per Dr. Waters Hon. Sec. Isle of Ely Division):			
Allan, Dr. James, Leeds ...	1	1	0	Howe, Dr. C. W., Haddenham ...	0	5	0
Per Dr. Millu (Hou. Treasurer Dundee Branch):				Beckett, Dr. F. H., Ely ...	0	5	0
Dundee Branch Vol. Fund ...	5	5	0				
Miller, Dr. G. W., D.S.O., Dundee ...	1	1	0				£952 4 0
Rorie, Dr. G., Dundee ...	1	1	0				

THE Egyptian Government has allotted 5 million piastres for the erection of a large hospital in the island of Rhodes in the Nile, near Cairo.

ON May 11th a memorial tablet was unveiled by the Bishop of Liverpool to the memory of the members and associates of the Liverpool Medical Institution who gave their lives in the service of their country during the war. The tablet was the gift of Mr. W. The-wall Thomas, ex-president of the Institution.

England and Wales.

DINNER OF THE NEWCASTLE GLASGOW UNIVERSITY CLUB. MEMBERS of the Glasgow University Club of Newcastle-on-Tyne dined together on May 6th under the genial presidency of Dr. Robert Forsyth, of Cramlington. The University guests were Professor Ralph Stockman and Mr. Robert H. Parry. But for the miners' strike and the difficulty of railway travelling more than the sixty-four gentlemen would have been present. After the loyal toast from Chair had been honoured, that of "Alma Mater" was submitted by the Rev. Alex. Hastie, whose peroration on the motto of the crest of the University, "Via, Vita, Veritas," was highly appreciated. In a happy reply, Professor Stockman alluded to the extensive structural alterations which had become necessary, during the last twenty-five years, to meet the increase in the number of students in the University, and the new lectureships which had been created. Mr. Parry reminded the gathering that the University had the largest medical school in the country, and that of late considerable attention had been paid to the cultivation of post-graduate study. "Other Universities and Seats of Learning" was submitted by Dr. D. W. Inglis, of Hebburn, and acknowledged by Professor D. Drummond of the College of Medicine and Professor Bedson of the Armstrong College. A new feature on this occasion was the presence of representatives from other clubs and of the Students' Representative Council, in the persons of Dr. Hill Robertson, President of the Yorkshire Association of Glasgow University Graduates, and of Mr. P. A. Wilson, M.A., M.B., from Glasgow. Both of these gentlemen responded to their particular toasts; the latter in doing so made an appeal for funds to extend the buildings of the Students' Union in the University grounds and for field sports, etc. A most enjoyable evening was spent, to which Mr. T. Dodds, by his singing, contributed. Nothing could have exceeded the excellent manner in which the arrangements were carried out by Dr. J. T. Dunlop and Dr. James Hudson.

VENEREAL DISEASE CAMPAIGN IN DERBYSHIRE.

We have received from the County Medical Officer of Health, Dr. Sidney Barwise, a copy of the following notice, which, with the approval of the county council, is being posted throughout Derbyshire. It is headed "Venereal Diseases. A Warning! Issued by the Derbyshire County Council." The sentence "Prevention is better than cure" (printed below in italics) appears in large capital letters on the placard, and a variety of type is used throughout for the sake of emphasis.

"The only absolute means of preventing venereal disease is to avoid possible infection. There is risk in all irregular sexual intercourse. Amateurs are just as dangerous as professional prostitutes. Venereal diseases, unless promptly treated, may lead to insanity, blindness, stricture, paralysis, or premature death. Syphilis is among the chief of the 'killing diseases.' Those who have any suspicious sore or discharge should see a doctor at once, or go to a treatment centre.

"*Prevention is better than cure.* Venereal diseases are the easiest to prevent, but the hardest to cure. They can be prevented by scientific cleanliness. If tackled at once the germs are at our mercy while lying on the surface, but give them a few hours and they bury themselves so that disinfectants cannot reach them. Even if there are no symptoms, but a risk of infection has been taken, carry out at once the instructions given below.

"The disinfectants recommended are: Solution of potassium permanganate 1 in 2,000, or a teaspoonful of Condy's fluid to a pint of water; 33 per cent. calomel ointment. If exposure to risk has taken place, (1) make water; (2) thoroughly wash the parts with soap and water; (3) swab all over and thoroughly with permanganate solution or weak Condy's fluid on cotton-wool; (4) dry, and rub the calomel ointment thoroughly all over the parts. These precautions must be adopted within one hour or two of exposure. If it is impracticable to use soap and water the permanganate solution alone can be used and then the whole of the steps mentioned above should be repeated at the earliest possible moment. It should be remembered that these drugs are useful to prevent infection, but are no good for treatment of venereal disease. For treatment go at once to one of the treatment centres."

CENTRAL MIDWIVES BOARD.

A meeting of the Central Midwives Board for England and Wales was held on April 20th. Sir Francis Champneys was re-elected chairman, and in returning thanks he welcomed the new members of the Board, Dr. J. Johnstone

Jervis (appointed by the Association of Municipal Corporations), Dr. Robert A. Lyster (Society of Medical Officers of Health), Miss M. O. Haydon and Miss G. I. Da Silva Le Geyt (Ministry of Health), Miss Pollard and Miss Pearson (Incorporated Midwives Institute). The following reappointments to the Board were reported: Professor Henry Briggs, M.B., F.R.C.S., Lady Mabelle Egerton (by the Ministry of Health), Mr. Charles Sangster, M.R.C.S. (by the Society of Apothecaries).

Letters were read from the Ministry of Health approving (a) the balance of £4,905 18s. 9d. shown against the Board in the financial statement for the year 1920, for the purpose of the apportionment of contributions from Local Supervising Authorities, and (b) the proposed scale of expenses of witnesses attending on behalf of the prosecution at the hearing of penal cases approved by the Board at its meeting on December 21st last. It was agreed to forward a copy of the Revised Rules to the Minister of Health for approval, and to order that the new Rules should come into force on July 1st next for a period of five years. It was decided that having regard to the great expense involved in printing the Midwives Roll at the present time, the Roll for 1921 be not printed, but that the Provincial Rolls for 1921 be printed as usual.

Scotland.

THE ASSOCIATION OF SURGEONS OF GREAT BRITAIN AND IRELAND.

THE second annual meeting of the Association of Surgeons of Great Britain and Ireland was held in Edinburgh last week. It began on Thursday, May 5th, when Sir Harold Stiles was installed as President, and gave an address; afterwards a number of short papers were read. In the afternoon a visit was paid to the Royal Infirmary, and operations by Sir Harold Stiles, Sir James Hodsdon, Sir David Wallace, Mr. Henry Wade, Mr. Miles, Mr. Dowden and Mr. Scot Skirving were witnessed. Dr. Logan Turner gave a demonstration on suspension laryngoscopy and oesophagoscopy. The Sick Children's Hospital, where Mr. John Fraser was operating, was also visited. On the morning of May 6th there was a debate on indications and contraindications for prostatectomy and choice of method, opened by Sir Cuthbert Wallace and Sir David Wallace; on the afternoon of that day operations were again witnessed in the Royal Infirmary and the Sick Children's Hospital. In the evening there was a dinner in the Royal College of Surgeons. On Saturday morning demonstrations on some physiological experiments of surgical interest were given in the physiological department; Professor E. Sharpey Schafer showed a new method of determining pulmonary blood pressure, Dr. Walker demonstrated some anomalous effects of section of the cervical sympathetic, and Drs. Lim and Dott showed some artificial pecket fistulae. Afterwards Mr. D. M. Greig, conservator of the Museum of the Royal College of Surgeons of Edinburgh, demonstrated skulls of anatomical and surgical interest. During the meeting a museum of surgical pathology was arranged at the Royal Infirmary; among the specimens were collections of examples of congenital hypertrophy of the pylorus and stomach wall, shown by Dr. John Thomson; of fibromatosis of the stomach, by Dr. Alexis Thomson and Mr. J. M. Graham, of carcinoma of the oesophagus by Dr. Logan Turner, and of tuberculosis of the intestine by Dr. F. M. Caird. Sir Harold Stiles showed specimens and skiagrams to illustrate the varieties of cervical ribs, Dr. J. W. Dawson a collection of melanomata, and Dr. J. H. Gibbs dental cysts and edontemes. Demonstrations were given by Professor Lorrain Smith and Dr. Theodore Rettie on a new method of staining fats and lipins, by Mr. Richard Muir on the cells of the peritoneal exudate at varying periods after infection, and by Mr. D. P. D. Wilkie on intestinal diverticula. Dr. W. R. Logan gave a demonstration indicating the importance of nutritional environment on the life of bacteria. Among other collections of specimens was a series showing intracranial haemorrhage in the newly born, by Dr. F. J. Browne, and of the histological changes in experimental scurvy, by Dr. A. Marshall Findlay. Mr. John Fraser showed a large number of specimens illustrating tuberculosis of bone and

joint, and Dr. H. M. Traquair exhibited radiograms, charts of the fields of vision, and specimens illustrating points in the diagnosis of pituitary enlargement.

EDINBURGH WOMEN'S HOSPITAL AND HOSPICE.

At the annual joint meeting of the Edinburgh Hospital and Dispensary for Women and Children, and the Hospice, the report showed a deficit of nearly a thousand pounds, despite the fact that the receipts (£8,089) were £1,800 more than in the previous year. During the year 584 patients were admitted to the hospital, while the maternity cases attending at the hospice were 376, or 112 more than during the previous year. It was announced that a plan for the immediate realization of part of the Elsie Inglis Memorial had been adopted. The object of the fund—£11,863 had so far been subscribed—was the endowment of the hospice and its transfer from the High Street to a more suitable building. At present building operations were impossible, but it was decided to use the interest on £10,000 immediately by providing small private wards, consisting of two rooms each, in various parts of the city which were remote from hospital service. Here a mother would be cared for as in a nursing home, either for a period of rest before her baby was born, or for special care during and after confinement. One of these wards would be opened at once and others would follow as funds allowed.

Correspondence.

THE VALUE OF THE WASSERMANN REACTION.

SIR,—There are Idols of the Tribe, the Cave, the Forum, and the Theatre; and controversies in every sphere of human life, but especially, I think, in the scientific sphere, bear constant witness to the sway which they hold over the human mind. The Tribe of Mankind suffers from the delusion of the possibility of infallible knowledge, and is ever demanding from the doctors a sign. From time to time the doctors, victims to the same delusion, announce that a sign has been vouchsafed to them, and later have to admit that infallibility has once again eluded their grip.

So it has been with the Wassermann reaction. We doctors, or some of us, taught the public that the Wassermann reaction was an infallible indication of the presence or absence of syphilitic infection; and now we have the normal task of persuading them out of that false and dangerous belief. To all experienced and prudent medical men, whether clinicians or laboratory workers, it has always been apparent that a reaction of such character and delicacy could not attain mechanical and invariable accuracy; yet all such, whether laboratory workers or clinicians, would agree that when interpreted with intelligence and a regard for its essential limitations it is a diagnostic weapon absolutely necessary to the equipment of medicine.

There are, it seems to me, five principal causes for the contradictory and disappointing results which have recently been recorded. The first two are inherent errors of the reaction, and the belief to the contrary may be attributed to a worship of the Idols of the Tribe.

1. There are a certain proportion of cases of undoubted syphilitic infection which give negative results.
2. There are a certain proportion, smaller than the first, of non-syphilitic cases which give positive reactions.

The most careful investigators of the value of the reaction admit these sources of error, which, with our present knowledge, are inevitable, and, at any rate, of small importance in the total results.

3. There are difficulties of technique in the laboratory which are still not commonly recognized and may invalidate results.
4. There are too many Wassermann reactions done by laboratory workers who know the result expected by the clinician, or are themselves in charge of the patients.

Here I am venturing on controversial quicksands, so I must hasten to add that I do not for one moment impugn

the common honesty of the laboratory worker; I refer only to the acknowledged power of obsession upon the mental accuracy of all men. Clinicians and laboratory workers alike suffer from obsessions. Few clinicians enter upon the study of a difficult case with entirely unbiassed minds; the measure of their freedom is to a large extent the measure of their mental power. No laboratory worker who knows what is expected of him can enter on the performance of a Wassermann test without some degree of obsession which, to that degree, must impair his strict impartiality and degrade the value of his judgement. These are the Idols of the Cave.

5. The tendency of the clinician to accept a positive result as an explanation of the disorder from which his patient is suffering, regardless of the possibility that syphilis may be merely a coincidence. "*Gestit mens exsilire ad magis generalia, ut acquiescat.*"

Laboratory dogma is not necessarily truth, and the acceptance of it as such is an instance of the worship of the Idols of the Theatre. Let us recognize that infallible knowledge is not ours and proclaim that the Wassermann test properly performed and properly interpreted is not indeed a sign, such as foolish generations demand, but a very present help in the troubles both of patient and doctor.—I am, etc.,

London, W.1, May 7th.

HUGH THURSFIELD.

PULMONARY AND AORTIC BLOOD PRESSURE.

SIR,—Dr. Samways correctly explains the significance of the remarkable difference between the systemic and pulmonary blood pressure, but he does not touch upon the means by which the excess of systemic pressure is brought about.

Obviously, this difference is due to an excess of systemic over pulmonary resistance, but this excess is not due, as might be supposed, to the greater extent of the systemic system. A special physiological resistance is placed in the systemic circuit in order to provide the necessary head of systemic blood pressure. Remove this resistance and there remains what may be termed the anatomic resistance. This is surprisingly small and much the same in both circuits. The exigencies of the circulation demand that in each circuit the anatomical resistance shall be reduced to a minimum.

The engineering devices of the vascular system, both anatomical and physiological, are a marvel of perfection.—I am, etc.,

Wimpole Street, W.1, May 8th.

HARRY CAMPBELL.

THE SITE OF OPERATION FOR EMPYEMA.

SIR,—In your issue of April 30th Mr. H. Cameron Kidd raises the interesting question of the site of operation for empyema, and invites opinions on the relative merits of anterior, lateral, and posterior openings.

An extensive experience in the surgery of empyemata during the war (chiefly at a large base hospital in England), supported by cases in civil practice, confirms my belief that the site of the opening—provided it be at a proper level—is of little importance, and that success in treatment depends rather on (1) the method of drainage employed, and (2) the post-operative treatment of the case. It is, of course, to be understood that in each case the period of time that elapses before healing is complete also depends largely on the duration of the exudate in the pleural cavity prior to operative interference, while the size of the exudate and the nature of the infecting organism are not without influence.

In cases which had not been previously operated on I have employed each site with equal and uniform success, but I prefer the lateral or axillary route for reasons which I need not detail. In none of these cases was a second operation required to cure the empyema, but in a few instances it has been necessary to remove small sequestra from the divided ends of the rib before the sinus in the parietes would heal. Although I have tried various plans I have found no infallible method of preventing necrosis, but this has never been more than a strictly localized process, and has been easily remedied.

A very large number of unhealed cases came under my care at periods varying from a week up to three months subsequent to operation elsewhere—in one case four years

had elapsed and nine operations had been performed. All these cases had been drained either laterally or posteriorly. In many drainage was satisfactory, but in a considerable number it was inadequate and required prompt attention. In all cases I made use of the existing opening, and in all but three a cure was effected without further operation for the empyema. These three cases were of two and a half months', three months', and four years' duration respectively, and each required a subsequent thoracoplasty to effect a cure.

The points I would lay stress upon in the treatment of empyema are:

1. Early, free, and efficient drainage.
2. Early and regular post-operative breathing exercises.
3. Maintenance of free drainage until the lung has expanded and obliterated the cavity in the pleura.

It is unnecessary here to enter into details of the methods which I have found most successful in achieving these ends as I hope to deal with them in a future communication.—I am, etc.,

Dublin, May 6th.

WILLIAM PEARSON.

THE PREPARATION OF SCIENTIFIC PAPERS.

SIR,—I rarely read a leader in the BRITISH MEDICAL JOURNAL unless I have nothing to do and wish to while away the time with a little literary garbage of no intrinsic merit, but of some educational value as teaching one how not to write. In one of my idle moments I caught sight of your leader on the preparation of scientific papers. I had not proceeded far when I discovered that this article was based on "Notes upon the preparation of manuscripts and reports for publication," by the Medical Research Council. This discovery necessitated me verifying the references, and as I have ceased subscribing for this Council's periodical since its price was raised—I did not consider it worth the former charge of one guinea annually—this letter has been delayed.

Why the Medical Research Council should have found it necessary to issue such instructions I cannot say. They cannot have been drawn up for the edification of the half-dozen eminent men who edit the monthly periodical, as their work consists of reviews and abstracts of already published writings. The only legitimate inference which I can draw is that these instructions are for those who write the monographs and reports on sundry subjects published by the Research Council. This is how medicine progresses under the quasi-Government direction of the Medical Research Council. Personally, I am inclined to think that such researchers, as well as leader writers in the BRITISH MEDICAL JOURNAL, should be scrapped, or, as "Jacky" Fisher would have said, "sack the lot."

The BRITISH MEDICAL JOURNAL seems to be no less unfortunate in its contributors, but it is not quite plain how they display their disregard, as a negative is rather difficult to display unless it be that of a photograph. Possibly they may have such a high opinion of the Editor's literary talents that they may prefer to leave the whole of the editing to him—not a wise thing to do. The surgeons, on whom the editorial *anathema maranatha* has now fallen with as great a crash as that of the Tower of Sileam, seem not to be the only sinners, as some of the less culpable "may be guilty of the most unscientific lack of attention to details." I shall not worry over the meaning of this sentence, which might have been expressed more scientifically.

A few months ago I was much amused at the quaint phraseology of a child who had not completed her third year. When she wished to strongly express her disapproval of anything, she would solemnly exclaim, "for goodness sake!" What is amusing and interesting in the mental evolution of a child may be intolerable in a full-blown editor. Witness the Editor's "unwashed hands." The adjective unwashed is now obsolete except for a phrase in the Gospel of St. Matthew, and I don't know that "unwashed" ever had an existence outside the BRITISH MEDICAL JOURNAL. There is no verb to unwashen, whence then the past participle?

"But he ought not to be put to that test." Surely, in the name of common sense, this belongs to the previous sentence: "an experienced compositor acquires an extraordinary skill in deciphering careless writing." Why then is it tacked on to the next which does not require it?

Footnotes are among the undesirables, and should, when necessary, be incorporated in the text. You should follow a long way after Gibbon, whose footnotes "usually contained matter which he judged it becoming to veil," etc. Here the *it* like the footnote is superfluous.

The writer obtrudes the Medical Research Council at every turn, as if he had not got an independent opinion of his own. "Underlines," legends or descriptions, however, are sent to the printer"; but surely they are not simply sent "so that each drawing or diagram should be numbered." "A drawing should be made in Indian ink on stout paper." *With* Indian ink might answer better. There is a long diatribe by the Research Council on their valuation of illustrations, but there is nothing about word-painting, the cost of which is not at all prohibitive. It is certainly not advisable to publish the photographs of some authors unless you wish to damn the sale of their productions. If photographs were excluded there would be no danger that "the inclusion of inessential details in the background leading to confusion." For the sake of euphony I would substitute unessential, which has a better negative ring.

The mentor is very strong on the binominal system, though perhaps rather sparing in the use of capital letters for species. The *Elephas indicus* would scarcely seem to do justice to that gigantic animal. The *Trypanosoma brucei* does not derive its name from any inherited qualities which it possesses, but from its discoverer, Sir David Bruce. It has no relation to the African shrub *Brucea*, or the alkaloid *brucine*, which owe their names to another Scottish explorer, J. Bruce. I would be inclined to agree with the botanist rather than with the Editor or the Medical Research Council, and use a capital where the species derives its name from the discoverer rather than from any inherent qualities of its own. The *Bacillus welchii* is not a welcher, and, in honour of the distinguished pathologist who first described it, I would call it the *Bacillus Welchii*.

Editors as well as contributors are not above reproach. It is the duty of an editor to edit, and for that he is paid; the contributor seldom is. Of course it is mighty convenient if the contributor does the editing, but in that case the editor should be careful not to mutilate the work of the contributor who may be even more enlightened than himself. An editor may be a receptacle for universal knowledge, but he rarely assimilates much of the information which he receives; it is therefore becoming that he should veil his ignorance and recognize that there be more things in heaven and earth than are dreamt of in his philosophy. An editor should allow his ideas, if he have any, to flow freely, and never to become stereotyped. I believe it was Faraday who said: "In knowledge, that he alone is to be contemned or despised who is not in a state of transition."

An editor should have a fair working knowledge of his own language, and be able to spell, as the latter qualification is not an uncommon defect in many otherwise well educated writers. There is an American paper, to which I occasionally contribute, that has adopted phonetic spelling, and I am thus saved all trouble, as the printer does the spelling, and the intellectual editor does not mutilate my paper.

The following rules are offered gratuitously:

1. Only write when you understand what you are going to write about.
2. Have at your elbow a dictionary which contains at least your own vocabulary. You must not say a dictionary at your elbow as it is the dictionary and not your elbow which contains the vocabulary.
3. You can use any old scraps of paper for your manuscript; they should be carefully preserved, and on no account sent to the editor or printer, as in the very remote possibility of you or the article becoming famous they might be of some value.
4. Your article for the editor and the printer should be carefully typed and well spaced, on one side only of clean white paper, foolscap size, 13 by 8 in.
5. The typed article should be carefully read, turned upside down and inside out, viewed from every literary angle to see how it can be improved—and if it can be improved out of existence do not hesitate to act speedily. Make all corrections in block letters. If the corrections be numerous the revised version should be again typed.
6. In writing, the order and sequence of time should be strictly observed unless you be a disciple of Einstein, which should be stated, and in that case there need be no special observance of the fourth dimension.
7. Footnotes should be few and far between—the fewer the better.

8. You should never start a number with a decimal point. If the value be less than 1, then start your decimal with 0, which of course counts nothing, and does not disturb the equanimity of the printer, otherwise there is no knowing how he may multiply your decimal.

9. Have your typed pages numbered, and then fastened with an ordinary paper fastener.

10. In the way of illustrations the strictest economy should be practised. Drawings should be made on stout clean paper with Indian ink, and consecutively numbered, the probable places for their insertion should be indicated in the text. Reserve your photograph for the illustrated papers.

11. Be careful in your spelling, study the binominal system, and learn when and where to place capital letters.

12. Give the editor as little trouble as possible, and remember that printers' errors, whether made by you or the printer, cost money.

13. If you do not understand the foregoing instructions, send a stamped envelope to the editor for an illustrated reply.

—I am, etc.,

Liverpool, April 26th.

JAMES BARR.

* We apologize for "unwasheden," a blunder due to a clerical error overlooked in correction. For the rest, we find the rules of the Medical Research Council much better than Sir James Barr's, and better expressed.

SIR,—In your article of April 23rd, p. 612, in which you comment on the suggestions of the Medical Research Council on the preparation of authors' papers intended for publication, there is one recommendation which has a far wider application than that of scientific papers. I refer to the recommendation that the decimal point in a decimal fraction should always be guarded by a cipher before the point where there is no integer forming part of the whole figure. The omission of this precaution in writing prescriptions has led to more than one serious error, and has caused grave inconvenience to patients and possible damage. Decimal fractions appear frequently in prescriptions for glasses, and in these the omission of the guarding cipher has led to mistakes by the optician. I came across such a case not long ago where a prescription written $-.5$ D. sphere had been misread so that glasses of -5.0 D. sphere were supplied to the child, who had worn these wrong glasses for some three months before the mistake was discovered. If the prescriber had written -0.5 D. sphere no mistake could have been made. Similarly, -5 D. sphere should be written -5.0 D. sphere to ensure accuracy of the prescription. The inculcation of care in these matters assumes additional importance in the prescription of drugs as the metric notation obtains a wider vogue.

There is a point arising out of the printing of papers in which editors may assist authors. There is a growing and reprehensible custom on the part of editors (or printers?) of omitting to return author's manuscript when proofs of papers are sent to the author for correction. This omission often causes authors much unnecessary trouble. To-day I have received the proof of a paper containing numerous figures, but the typewritten script of the paper from which the printer had set up the proof has not been returned by the editor of the *Transactions* concerned. Apparently I am expected to refer to my original papers and not to have the benefit of seeing my final corrected paper in correcting this proof. In any case I take it that the manuscript of a paper is the property of the author, so that he is entitled to the return of it. Editors may reasonably demand scrupulous care on the part of authors in the days of high printing costs; equally authors may expect consideration at the hands of editors.—I am, etc.,

London, W., May 9th.

N. BISHOP HARMAN.

EVOLUTION IN RELATION TO DISEASE.

SIR,—The recent interesting letter on the above subject by Dr. Nash, with the leading articles in the *BRITISH MEDICAL JOURNAL* on March 19th and April 9th on etiology, seem to open up to us some new ideas of possible progress in the study of etiology, which one hopes may bear fruit in the ultimate checking and stamping out of diseases now only too prevalent amongst us.

It is very much to the discredit of our work as scientists that—in despite of the huge machinery of hospitals, laboratories, research societies, medical officers of health, and now recently a fully-blown Ministry of Health—so

little has actually been done of any proportionate value in the prevention of disease. We all have a duty to the nation which is beyond and above that which we owe to ourselves, and, if we are to have Ministers and medical officers of health, the improvement of the health of the people and the exclusion of disease should be their main business in life. There is yet so much to be done. There are so many problems at which we can only nibble and conjecture about, and which are beset with so many difficulties that a solution may seem almost impossible at present.

The recently established connexion of herpes zoster and varicella is opening a way for further research and observation which may lead us to new ideas and facts in the co-relation of diseases. Mere statistical records of the prevalence of diseases prove nothing beyond the figures they express. The figures are stated, the facts are verified, and it ends there. But the same incidence of disease, with the same prevalent mortality goes on from year to year unchecked and undiminished, and the mere recording of numbers serves only as a record of averages for which we are none the better. We find that certain diseases occur in waves, or periodical epidemics. We all know that it is so. And we know that disease is not the same everywhere. Each country has its own fauna and flora, and its flora of diseases. Here in this country, for example, measles recurs every two to four years, picking out children of from 3 to 6 years of age; pneumonia, with influenza, every spring. What we really want to know is whence does the virus come? And the questions which we should endeavour to answer are—when? whence? and how?

The position at present is something like this: "Your child has cerebro-spinal meningitis." "What is the cause of it, doctor?" the anxious mother asks us. Then we learnedly reply, "The *Diplococcus intracellularis* of Weichselbaum." "But where did it come from, doctor?" is the next question. This we can only evade answering, unless we say, "I presume, madam, from Germany, where Weichselbaum discovered it." One who has been in practice for many years sees these sporadic cases, and recurring waves of diseases, and feels helpless against them. The isolated sporadic cases are even more bewildering as being infectious or contagious in nature, and in these, as far as can be ascertained, there is no known possibility of a source of contagion. We need to know the origin of the virus, the source of the cause, which is prodigiously the most important for them and for us. This is particularly noticeable in anterior poliomyelitis, cerebro-spinal fever, and recently in encephalitis lethargica, in which one or two cases only may occur in a large town or district. Has the virus reached the sufferer from another distant victim? Virchow laid down the law of cellular pathology of *omnis cellula e cellula*. Is it also *omnis morbus e morbo, omne bacterium e bacterio*?

I am not a bacteriologist nor an epidemiologist, but I have seen things occur that have seemed to me wondrous strange. I have read and heard enough of carriers of disease, and I want to know more of carriers of cure. I wish to know more of channels of disease and, with them, of channels of cure. The instance of Tyndall's work on "Dust and Disease," quoted in the *JOURNAL* of April 23rd, p. 622, is much to the point. It has struck me that we may be living domestically at home with diseases in our own houses and gardens. I do not mean those only of cats, dogs, horses, birds, etc., but that we should pay more attention to the blights and various fungi that infest fruit trees, shrubs and roses in our gardens. The pathology of plants is a vast field for new research in comparative pathology. The fungi themselves may be the hosts of bacteria of many kinds. Various bacteria and bacilli have already been found to be essential to the existence of most of the Leguminosae family, in that they set free the nitrogen in the soil which is necessary for the production of the nitrites and nitrates which they need for assimilation and growth. Here is a cue. Let it be seized on and worked at by those who have the means of research in their hands.

The striking influence of insects as carriers of disease is now well known. Bacteria must be pretty ancient creatures. They had their world to themselves for many thousands and millions of years unnoticed and unconsidered. How are they evolving? Are they true to type or are they changing? There can be no doubt that they intermix freely to such

an extent that no pure culture from any one form is possible. This great class of saprophytes is now sitting on the top of the mountain of all pathology. But, as you wisely say in your leading article of March 19th, "It takes something more than a bacillus to bring into being an epidemic disease." One already sees changes of type from thirty to forty years ago. Typhoid is now nearly always a mild disease, and is becoming very rare; scarlet fever is notoriously milder in form; pneumonia, since the pneumococcus went into partnership with the *Bacillus influenzae* and streptococcus, has given us that fatal type of septic pneumonia which is so dreadful to encounter. The old days of the crisis on the sixth day have almost disappeared. One would like to know more from those who are competent to speak on the subject as to what connexion there is between plant diseases and those of the human species.—I am, etc.,

Enfield, April 24th.

FRED. TRESILIAN, M.D., F.R.C.P.

SIR,—The communications on evolution and disease which have been appearing in the BRITISH MEDICAL JOURNAL lately are not only of great interest from a biological point of view but have a very direct bearing on the etiology of disease, and consequently are worthy of the careful study of the medical profession. The evidence now before us seems to indicate very pointedly that *saprophytes* may be converted into *pathogenic organisms*, and so give rise to disease in the animal body; and one is tempted to accept the view that all infections and communicable diseases may have originated in this manner—namely, by modifications of the lowest forms of life. For example, may not the tubercle bacillus have originated in this way?

Dr. Bonney of Denver, in his work on pulmonary tuberculosis (ch. iii) discusses the various micro-organisms resembling the tubercle bacillus, and in connexion with one of them (the timothy-grass bacillus) he says:

"Growth is possible on all nutritive media, and is most pronounced at about 37° C. Its morphologic and tinctorial characteristics are practically indistinguishable from the true tubercle bacillus. In addition to its exact likeness in size and form to the tubercle bacillus, and in its resistance to decolorization, it was found that upon experiments with lower animals it was possible to produce almost the same lesions as with the bacillus of Koch."

And at p. 41 he says:

"It would seem that nowhere in the domain of bacteriology is there presented so fertile a field for original research as in the investigation of the possible practical significance of these bacteria, and the degree or character of their relationship to the tubercle bacillus."

Again, the seasonal occurrence of epidemics of enteric fever seems to point to the possibility of a saprophytic form of Eberth's bacillus which in the autumn acquires a virulent potentiality as the result of a hot summer. Plague we know is closely associated with rats. These rodents are particularly susceptible to plague, and may not the *B. pestis* in a saprophytic form find in them a suitable host for developing into the pathogenic form? In actinomyces we have a plain case of a saprophyte (the ray fungus) giving rise to disease in animals and man.

Turning to the animal kingdom, we have the lowly unicellular protozoan—the *Plasmodium malariae*—acting as a parasite and playing havoc with the red blood corpuscles of mankind.

The conviction is borne in on one that it is to the lowest forms of animal and vegetable life that we have to look for the origin of our "disease germs."—I am, etc.,

JAMES W. ALLAN, M.B., C.M.,
F.R.F.P.S.G.

Bellefield Sanatorium, Lanark, May 2nd.

NAPOLEON AND MURAT.

SIR,—The interesting leading article on Napoleon in the JOURNAL of May 7th contains a reference to "the most fearless cavalry officer the world had ever seen" as having been found "in the person of a common postillion of a country inn." Doubtless you refer to Napoleon's great cavalry leader, Marshal Murat, Duke of Berg, and King of Naples.

The accuracy of this description of Marshal Murat's origin may be questioned. It is true that he was the younger son of Pierre Murat, who owned the inn and

posting house at La Bastide, in the Department du Lot. But Pierre Murat was, for his station, a prosperous man, who besides being an innkeeper and small yeoman farmer was intendant or agent for the Talleyrands, the great landowners of the neighbourhood. His son, Joachim, was educated for ten years for the Church, first at the college of Cahors, and afterwards at the archiepiscopal seminary at Toulouse, where the future Marshal of France was one of a community of students *en soutane*, busy with philosophical and theological studies. When nearly 20 years of age Murat discovered that he had no vocation for the priesthood, but longed for a life of adventure. He suddenly left the seminary and enlisted in the regiment of Chasseurs à Cheval de Champagne, then halted at Toulouse on a route march.

This was in February, 1787, two years before the Revolution made all things possible, even for a private of Chasseurs.—I am, etc.,

Penrith, May 8th.

J. EDWARD BOWSER.

DIFFERENTIAL STAINING OF CARCINOMATA.

SIR,—I regret I cannot accept Dr. Knyvett Gordon's lightning condemnation of my method. I have used this method and held my peace for two years, but he has burst into song in almost as many hours. I would like to hear the mature views of an expert histologist. They may be equally sceptical, but would be more satisfying. I have offered to stain some of Dr. Gordon's sections for him.

I thought I had made it clear that the differentiation referred to does not "get up and hit one in the eye." It takes practice to get one's stains working nicely and also practice to pick out isolated cells. I would finally answer my lightning critic by saying that I do not depend on a stain for distinguishing between a leucocyte and an epithelial cell, but I find a stain which helps me to differentiate between a carcinoma cell and an endothelial cell very useful.—I am, etc.,

Eastbourne, May 7th.

A. G. SHERA, M.D.

Universities and Colleges.

UNIVERSITY OF OXFORD.

At a congregation held on April 28th the degree of Doctor of Medicine was conferred upon Edward O'Connor.

Wilde Readership in Mental Philosophy.—The electors to this readership intend shortly to proceed to the election of a reader. The emoluments of the readership amount at present to £400 a year. Candidates are requested to send in their applications, with such evidence of their qualifications as they may desire to submit, to the Registrar of the University so as to reach him not later than June 1st, 1921. An extract from the regulations is published in the *University Gazette* (Clarendon Press), April 21st, 1921.

Diploma in Public Health.—The Board of the Faculty of Medicine has issued (*University Gazette*, April 21st) the new syllabus of examination, which will come into force in Michaelmas Term, 1921. The examination in "General Pathology with special relation to Infectious Diseases" (paper, practical work and viva voce) is transferred to Part I; and a practical and viva voce examination in pathology and bacteriology is retained in Part II.

Rolleston Memorial Prize, 1922.—The next award of this prize, which is of the value of about £100, will be made in the Summer Term of 1922. The prize is awarded for original research in any subject comprised in the following list: Animal and Vegetable Morphology, Physiology and Pathology, Anthropology. Candidates must forward their memoirs to the Registrar before March 31st, 1922. The conditions of eligibility are published in the *University Gazette*, April 27th, 1921.

UNIVERSITY OF CAMBRIDGE.

At a congregation held on April 29th the following medical degrees were conferred:

M.D.—C. R. Taylor.
M.B., B.Ch.—P. F. Bishop.
M.B.—E. H. H. Granger.
M.Ch.—H. B. Dodwell.

Dr. J. N. D. Scott, of Edinburgh, has been elected to the John Lucas Walker Studentship.

Examinations.—The third examination for medical and surgical degrees will be held from June 14th to 23rd. Part I (Surgery and Midwifery) begins on Tuesday, June 14th, and Part II (Principles and Practice of Physic, Pathology and Pharmacology) on June 15th. The M.Ch. examination will be held on June 14th, 17th and 18th.

UNIVERSITY OF LONDON.

Presentation Day.

THE PRINCE OF WALES attended the presentation day ceremony of the University at the Royal Albert Hall on May 5th. The vice-chancellor, Dr. Russell Wells, presided, and read a letter from the chancellor, Lord Rosebery, who was unable to attend owing to indisposition. The Prince received the first degree in the Faculty of Commerce—the honorary degree of Master of Commerce; he also received the honorary degree of Doctor of Science.

A large number of ordinary degrees were afterwards conferred, and the principal officer, Sir E. C. Perry, presented a report on the work of the University during the year 1920-21. It stated that the number of candidates for matriculation and registration was 6,638 in 1913-14, and 15,539 in 1920-21. The number of candidates for degrees (1,746, of whom 1,035 were internal and 710 were external) showed an increase on the previous year, but a decline as compared with 1913-14; the entries for the bachelors' and the higher degrees are of course dependent on the conditions existing from three to six years ago. Under the head of benefactions reference was made to the offer of the Government of a site of eleven and a half acres in Bloomsbury for the new headquarters: the offer, made in May, was accepted in October. Cordial appreciation was expressed of the generous gift of the Rockefeller trustees to the University on behalf of University College and University College Hospital Medical School for the advancement of medical education and research; the necessary building and equipment schemes had been instituted and the laboratory teaching at the College and the clinical instruction at the medical school have already been developed in accordance with the intentions of the trustees. The late Sir William Dunn bequeathed £2,000 for an institute of medical sciences, at one time proposed but abandoned. The executors of his will have, however, presented the amount to the University on condition that it is expended upon one of the subjects which would have been embraced by the institute had it come into existence.

Graduates and undergraduates of the University had subscribed to purchase a fourteenth century illuminated manuscript relating in Norman French verse the life and feats of arms of Edward, Prince of Wales, the Black Prince. In the manuscript the motto of the Prince of Wales appears in the form "Ich Dene," which is held to indicate that the motto originated in the Low countries, not in Germany. In view of the industrial situation a dinner, which was to have been held in the evening of Presentation Day, was cancelled, but the Prince attended a daylight reception at the Guildhall, when the manuscript was presented to him. Subsequently the ordinary degrees were conferred.

The Senate.—The semi-general election of members of the Senate for the period 1921-25 has been completed. The medical representatives chosen are: By the Faculty of Medicine, Mr. H. J. Waring, M.S.; by Convocation, Dr. E. G. Graham Little; by the Royal College of Physicians of London, Sir Wilmot Herringham; by the Royal College of Surgeons of England, Mr. Raymond Johnson, M.B., B.S.

Advanced Lectures.

A course of four lectures (in English) on "The interpretation of the structure of the brain" is being given in the Department of Anatomy, University College, Gower Street, W.C.1, by Dr. C. U. Ariens Kappers, Director of the Central Institute for Brain Research, Amsterdam, at 5 p.m., on May 13th, 17th, 19th, and 20th.

A course of eight lectures on "Experimental studies in vegetable physiology and vegetable electricity" will be given by Professor A. D. Waller, M.D., F.R.S., and Mr. J. C. Waller, M.A., in the Physiological Laboratory of the University, South Kensington, S.W.7, at 5.15 p.m., on Wednesdays, May 18th, 25th; June 1st, 8th, 15th, 22nd, 29th; and July 6th.

A course of eight lectures on "Metabolism of cholesterol and the sterols" will be given by Mr. J. A. Gardner, M.A., at the London (Royal Free Hospital) School of Medicine for Women, 8, Hunter Street, Brunswick Square, W.C., at 5 p.m., on Tuesdays, May 17th, 24th, 31st; June 7th, 14th, 21st, 28th; and July 5th, 1921.

The above lectures are addressed to advanced students of the University and to others interested in the subject. Admission is free, without ticket.

VICTORIA UNIVERSITY OF MANCHESTER.

THE DEGREE of Litt.D. has been conferred under Charter II (3) upon Dr. Grafton Elliot Smith, F.R.S., formerly professor of anatomy in the university, and that of D.Sc. upon Sir Ernest Rutherford, F.R.S., formerly professor of physics.

Sir William Thorburn has been appointed Emeritus professor.

LONDON INTER-COLLEGIATE SCHOLARSHIPS BOARD.

SEVENTEEN Medical Entrance Scholarships and Exhibitions of an aggregate total value of about £1,580, tenable in the Faculty of Medical Sciences of University College and King's College, and in the medical schools of Westminster Hospital, King's College Hospital, University College Hospital, the London (Royal Free Hospital) School of Medicine for Women, and the London Hospital, will be offered for competition on Tuesday, June 28th, 1921. Full particulars and entry forms may be obtained from the Secretary of the Board, S. C. Ranner, M.A., The Medical School, King's College Hospital, Denmark Hill, London, S.E.5.

The Services.

AUXILIARY R.A.M.C. FUNDS.

THE annual general meeting of the Auxiliary Royal Army Medical Corps Funds was held on April 29th at 11, Chandos Street, Cavendish Square, W. 1, with Lieut.-General Sir John Goodwin, D.G.A.M.S., in the chair. The honorary secretary, Sir William Hale White, submitted the annual report, which showed that grants had been made in the Benevolent Branch to 27 widows, and in the Relief Branch to 76 widows. The amount distributed in the Benevolent Branch was £1,778, and in the Relief Branch £2,615.

Two new trustees were appointed, namely, Colonel Ewen Maclean and Mr. Martin Holt.

The honorary treasurer submitted the financial statement, which was of a most satisfactory character; £2,064 was received in subscriptions and donations for the Benevolent Branch, and interest £631. For the Relief Branch, £2,617 in subscriptions and donations, and £815 from interest.

The Director-General was re-elected president. Colonel Sir John Bland-Sutton was appointed to the vacancy among the vice-presidents, and the following were elected members of the council: Colonel W. H. Willcox, C.B., C.M.G., Colonel C. R. Evans, D.S.O., Colonel Donald Armour, C.M.G., Colonel Joseph Griffiths, C.M.G.

These funds were instituted by Lieut.-General Sir Alfred Keogh, G.C.B., late Director-General of the Army Medical Service, for the benefit of the orphans of the commissioned officers and the children of those severely disabled, who served during the late European war, and to give relief to the widows and orphans of the rank and file who were killed in action or died of wounds or illness contracted in and by the service during the late European war, of the three auxiliary branches of the R.A.M.C., namely, the Special Reserve, Territorial Force, and the New Armies.

Obituary.

EDWARD WARD, F.R.C.S.,

Consulting Surgeon, Leeds General Infirmary.

WE regret to announce the death of Mr. Edward Ward, of Leeds, which took place on April 30th. Mr. Ward was born at Ilorbury, near Wakefield, and after graduating B.A. of Trinity College, Cambridge, in 1876, he was studying law when the sudden death of his father led him to turn aside to medicine. He became a medical student at the old Leeds medical school, taking the M.R.C.S. in 1881 and the M.B., B.Ch. Cantab. in 1884. He was long associated with the Leeds General Infirmary, first as a medical student, then as resident surgical officer, later as senior honorary surgeon, and finally as consulting surgeon. He held the post of consulting surgeon to the Leeds City Police. In 1904 the Royal College of Surgeons elected him to a Fellowship, as a member of twenty years' standing, an honour that he greatly prized. He was professor of surgery in the old Yorkshire College, Leeds, and later at the University of Leeds, and he was an examiner in surgery at Cambridge University. He was a former president of the Leeds and West Riding Medical Chirurgical Society, and a member of other scientific bodies. In 1909, when he retired from active duty at the General Infirmary, the board passed a resolution placing on record their appreciation of his nineteen years' services. An accomplished pianist and an ardent lover of music, Mr. Ward took a great interest in the Leeds Triennial Musical Festival and was a member of the committee. A skilful operator, and a consultant whose opinion was much esteemed, Mr. Ward was a surgeon who worthily upheld the great reputation of the Leeds school of surgery. He was unmarried.

THOMAS EDWARD HONEY, M.D.

DR. THOMAS EDWARD HONEY, who died at his residence in East Looe, Cornwall, on April 30th, was a native of Devonport. He was educated at St. Mary's Hospital and at Newcastle-on-Tyne, and took the diplomas of M.R.C.S. Eng., L.R.C.P. Lond., and the M.B. degree of the University of Durham in 1886; he proceeded M.D. in 1889. After holding the posts of resident obstetric officer, house physician, and house-surgeon at St. Mary's Hospital, he was for a short time in practice in Devonport, and became surgeon to the Provident Dispensary of the Royal Albert Hospital there. Subsequently he entered the Royal Navy, retiring some years ago with the rank of staff surgeon. During the war Dr. Honey offered his services to the St. Marylebone Infirmary, in which the number of occupied beds became greatly increased when the neighbouring infirmaries

were reserved for military patients. After serving as first assistant medical officer he acted for the medical superintendent during the latter's absence through illness. The work was very strenuous, and Dr. Honey never quite recovered from the effects of the strain. A colleague who was with him at St. Marylebone Infirmary writes: I first met Dr. Honey in January, 1916, when he volunteered to replace one of the younger medical officers who was joining up for military service. He was then over 50 and had for some years past retired from the Navy and lived in the country, which he loved. He stayed with us for just over three years—much longer than he should have done had he considered the effect upon his health. His own interest was, however, the last thing he seemed to lay stress upon. He was at all times a model of conscientious care and never deviated from the highest standard of courtesy and consideration for his patients. Even after he left us he never forgot the dullness of the lives of the chronic and helpless patients and found time to write chatty letters to them. During the influenza epidemic of 1918 he did yeoman service, and though he caught it himself he returned after a few days' convalescence to take full charge of the Infirmary owing to the illness of the medical superintendent. Coming at the end of much strenuous work this undoubtedly aged him. Many have been the expressions of regret on hearing of his death.

We regret to record the death of Dr. JOSEPH YOUNG of Slamannan, Stirlingshire, at the age of 66 years. Dr. Young received his medical education at the Universities of Edinburgh and Glasgow, and qualified, with the Scottish triple qualification, in 1887. He was parochial medical officer, public vaccinator, factory surgeon, and post-office surgeon at Slamannan, and he was a lecturer and examiner to the St. John Ambulance Association. He was for many years a member of the British Medical Association, and he was well known and esteemed over a wide area in Western Stirlingshire. He retired from active medical practice only last year, and he is survived by a widow and a son.

DR. WILLIAM MASKELYNE PARHAM died in the Pensions Hospital, Denmark Hill, on May 2nd, after a long illness, the result of an accident on active service. He was the eldest son of the late William Parham of Bath, and was educated at Edinburgh, where he graduated M.B. and C.M. in 1889, and M.D. in 1892, taking the surgery prize in the final M.B. examination. After serving as demonstrator of physiology in Edinburgh University, as house-physician and surgeon of the Brecon County and Borough Infirmary, and as a civil surgeon in the South African war, he went into practice at Dyke Road, Brighton. He held a commission as captain in the 4th Battalion (Territorial) of the Royal Berkshire Regiment. He served in the South African war in the operations in Cape Colony and the Orange River Colony, was wounded, and received the Queen's Medal with three clasps. He served also in the late war.

DR. CASPAR ROBERT LAURIE died at Wadebridge, Cornwall, on April 22nd, aged 64. He was educated at St. Bartholomew's Hospital, and took the L.S.A. in 1884 and the L.R.C.P. Lond. and M.R.C.S. in 1885. He received the honorary degrees of A.M. and M.D. from Buffalo University, U.S.A., in 1890. He was for some time in practice at Redruth, Cornwall, where he held the post of surgeon to the West Cornwall Miners' Hospital and Women's Hospital at Redruth, and afterwards resided at Lee-on-Solent, Hampshire. He took a commission in the Dorsetshire Volunteer Garrison Artillery in 1893 and became Major in the R.A.M.C. (T.F.), on July 26th, 1905. He was a Knight of Grace of the Order of St. John of Jerusalem and an Assistant Commissioner of the St. John Ambulance Brigade.

The death is announced, at Rhos-on-Sea, in his 80th year, of Dr. WILLIAM SLINGSBY MANN, who for over forty-five years was one of the leading medical practitioners in Edgbaston, Birmingham. Educated at the medical school of Birmingham, Dr. Mann qualified as M.R.C.S. in 1864 and L.S.A. in 1867. He was consulting surgeon to the Birmingham Lying-in Charity and also to the Magdalen Home, and he was for many years connected with the St. John Ambulance Association as lecturer and examiner. On his retirement in 1912 a medal was presented to him

in recognition of his services to the association. For some years Dr. Mann was honorary secretary of the Midland Medical Society. He is survived by his widow, four daughters, and one son, his younger son having been killed in the war.

DR. WILLIAM MORRISON, of Ballarat, Victoria, Australia, died on January 24th from angina pectoris. He was born at Elgin, Scotland, in 1856, graduated M.A. Glasgow in 1877, M.B., C.M. in 1881, and M.D. in 1884. Soon afterwards he went to Australia and graduated M.D. Melbourne in 1885. His father was for many years rector of the Glasgow Academy, and the late Dr. George Ernest Morrison, the well-known Peking correspondent of the *Times*, was his cousin. After being for a short time in partnership with the late Dr. Foster, of Colac, Victoria, William Morrison was appointed Resident Medical Superintendent of the Ballarat Hospital in 1885. A year later he joined Dr. Bradford in general practice in Ballarat, and there for thirty-four years continued to command the respect of his colleagues, patients and friends. He cultivated many interests outside medicine; he worked assiduously for the Art Gallery, for the Ballarat College, and for St. Andrew's Kirk. His hobbies were gardening and birds; he was widely read and a fervid Scot, with an intense admiration for Barrie. A friend writing of him in the *Medical Journal of Australia* says: "He was a staunch friend, slow to make friendships, but constant to those whom he counted among his friends. He was, perhaps, often too outspoken, but his criticism was tempered by a quaint Scottish humour." Dr. Morrison is survived by a widow and one daughter.

Medico-Legal.

PROSECUTION UNDER THE MEDICAL ACT.

AT Nuneaton Police Court on May 5th, John Richard Taylor was summoned on three counts: (1) falsely using the description of doctor, implying that he was registered under the Medical Act, 1853; (2) falsely pretending to be a doctor of medicine; (3) falsely pretending to be a surgeon. Mr. G. D. Roberts prosecuted on behalf of the Medical Defence Union; Mr. H. Barrett defended, and pleaded "Not guilty" on behalf of his client.

According to the report in the *Nuneaton Tribune* of May 5th, 1921, Mr. Roberts said that the evidence on all three charges was the same. It was alleged that defendant called himself by titles which the Medical Act prohibited him from using. The object of the Medical Act of 1853, under which the proceedings were taken, was to enable the public to distinguish between qualified and unqualified men, and prevent them from being misled. It did not prevent unqualified men from practising, but they must not pretend to be registered. Mr. Taylor was not registered. He came to Nuneaton in April of this year, and established himself at Abbey Chambers, holding himself up as a person qualified to attend the public for their eyesight, to prescribe for them, and to give them advice. He advertised freely, but not being registered he could not be criticized or proceeded against for that, though no medical practitioner could advertise. Counsel having handed in copies of the *Midland Daily Tribune* containing defendant's advertisement, said there were passages in the advertisement which the prosecution contended constituted an offence under the Act. It was headed "Nuneaton's Great Opportunity," and referred to "Dr. John R. Taylor, Eye Specialist and Consulting Oculist, late Ophthalmic Surgeon, Royal Army Medical Corps." The use of the word "surgeon" in the advertisement was, counsel submitted, a direct breach of Section 40 of the Medical Act, 1853. Mr. Taylor might be a most excellent man, but he could not call himself a member of the medical profession when he was not registered.

Mr. Barrett, on behalf of the defendant, who admitted responsibility for the advertisement, submitted that he had no case to answer. There was no evidence, he said, that his client had pretended to be anything he was not; the Chairman, however, said that the Bench considered there was a case to answer.

Defendant then gave evidence. He said he had been carrying on business at Abbey Chambers, as an eye specialist, for the last two or three weeks. He was an Englishman by birth. He went to America in 1885 and entered the College of Surgeons and Physicians in Chicago in 1895 or 1896, and took the M.D. degree there in 1899. He was a surgeon in Chicago, Michigan, Wisconsin, and at the Wells Eye Hospital, Philadelphia. During the war he came to England at the request of the army authorities, and was appointed a civilian medical practitioner. He was appointed surgeon with the rank of captain, with the British Expeditionary Force, and was stationed from 1915 to 1916 at the 23rd General Hospital, Etaples. In June, 1916, he was appointed civil medical officer at the Military Hospital, Colchester. He served on a civil medical board and on the medical board of ophthalmic surgeons. His name appeared in

the *Army List* as "Taylor, J. R., M.D., commission, 23rd August, 1913." He had official letters addressed to him as Captain Taylor. In reply to the Chairman, he said it was not possible for him to register in England, as he would have to go through a course before getting his degree, and his age precluded this.

The Bench said there could be no question that an offence had been committed. In view of defendant's past services, and that he was capable in every way, a nominal fine of 5s. in each case would be imposed, with two guineas costs.

Medical News.

SIR CLIFFORD ALLBUTT'S book on Greco-Roman medicine is nearly ready for publication. It is founded on the two courses of FitzPatrick lectures he gave before the Royal College of Physicians on Greek medicine in Rome.

In connexion with the visit of the Crown Prince of Japan to England the King has conferred the decoration of G.C.V.O. upon Professor Kinmosuke Miura, M.D., of the University of Tokio.

PRINCESS ALICE, COUNTESS OF ATHLONE, will open the Crewe House Bazaar, in aid of the Great Northern Hospital, on Thursday, June 2nd, at 3 p.m.

THE celebration of Founder's Day at the University of Bristol will take place on Tuesday, May 24th. At 11 a.m. there will be a special service in the Cathedral. At 3 p.m. a cricket match will be played between the University and the Gentlemen of Gloucestershire, and there will be tennis matches on the University athletic ground, Coombe Dingle. The usual evening reception has been abandoned this year in consequence of the present unsettled state of affairs.

A COURSE of clinical lectures and demonstrations will be given at the Queen's Hospital for Children, Hackney Road, E., commencing on Thursday, May 19th, and concluding on June 30th. The lectures are free to medical practitioners and students of medicine. Particulars may be obtained from Dr. Kenneth Lees, 48, Harley Street, W.

DR. ALEX. G. GIBSON, lecturer in morbid anatomy, University of Oxford, will deliver the Schorstein Memorial Lecture at the London Hospital Medical College on Friday, June 3rd, at 4 p.m. The subject selected is chronic inflammatory diseases of the spleen. Members of the medical profession are invited to attend.

THE Aberdeen University Club, London, will hold its bi-annual dinner on Thursday next, May 19th, at 7.30 p.m., at the Criterion Restaurant, and the secretary, Dr. W. A. Milligan, 11, Upper Brook Street, W.1, will be glad to hear from any Aberdeen graduates who would like to be present on that occasion. Professor J. A. MacWilliam will occupy the chair.

THE annual dinner of the National Medical Union will be held at 7.15 p.m. on Saturday, May 28th, at the Monico Restaurant, Piccadilly Circus. The London president of the Union, Dr. Alexander Blackhall-Morison, will make a communication on "A project for the formation of a General Medical Council representative of the whole profession as a body related, on the one hand, to the public and, on the other, to the Government of the country and Empire." Tickets, price 10s. 6d., exclusive of wine, may be obtained from the honorary secretary, Dr. E. H. Worth, 2, Aldrington Road, Streatham, S.W. 16.

THE Rockefeller Foundation has endowed a training college for nurses in Brussels, in memory of Nurse Edith Cavell and Madame Depage. Nurse Cavell was shot by the Germans in Brussels in October 12th, 1915. Madame Depage, who became so well known to surgeons in Europe and America during the years when her husband, Professor Depage, was secretary of the International Surgical Society, was drowned when the Germans torpedoed the *Lusitania* on May 7th, 1915.

DR. ALBERT CALMETTE, director of the Pasteur Institute at Lille, whose important observations on tuberculosis were recently described in the *JOURNAL*, has been elected a foreign member of the Royal Society.

ACCORDING to a recent census the population of Germany was 59,668,000 in October, 1919, as compared with 63,052,000 in 1910.

EXCLUSIVE of the population of Alaska and soldiers and sailors on foreign service, the population of the United States on January 1st, 1920, was 105,683,108, as compared with 91,971,266 in 1910 and 75,934,575 in 1900.

AT the meeting of the Röntgen Society to be held at 8.15 p.m. on Thursday, May 19th, in the Physics Lecture Theatre of University College, London, Madame Curie will be elected an Honorary Member, and Professor A. V. Hill, F.R.S., will deliver the fourth Silvanus Thompson Memorial Lecture, on "Electrical Instruments and Phenomena in Physiology."

THE annual dinner of the West London Medico-Chirurgical Society will be held at the Wharfedale Rooms, Hotel Great Central, on Thursday, June 2nd, at 7 for 7.30 o'clock.

OWING to the scarcity of nurses, several wards have had to be closed in the Allgemeines Krankenhaus at Vienna.

THE age limit in German universities has been reduced from 70 to 65, thereby causing thirty-seven vacancies in the professorial chairs in the University of Berlin alone.

Letters, Notes, and Answers.

As, owing to printing difficulties, the *JOURNAL* must be sent to press earlier than hitherto, it is essential that communications intended for the current issue should be received by the first post on Tuesday; and lengthy documents on Monday.

ORIGINAL ARTICLES and LETTERS forwarded for publication are understood to be offered to the *BRITISH MEDICAL JOURNAL* alone unless the contrary be stated.

CORRESPONDENTS who wish notice to be taken of their communications should authenticate them with their names—of course not necessarily for publication.

AUTHORS desiring reprints of their articles published in the *BRITISH MEDICAL JOURNAL* are requested to communicate with the Office, 429, Strand, W.C.2, on receipt of proof.

IN order to avoid delay, it is particularly requested that ALL letters on the editorial business of the *JOURNAL* be addressed to the Editor at the Office of the *JOURNAL*.

THE postal address of the *BRITISH MEDICAL ASSOCIATION* and *BRITISH MEDICAL JOURNAL* is 429, Strand, London, W.C.2. The telegraphic addresses are:

1. EDITOR of the *BRITISH MEDICAL JOURNAL*, *Ailology*, Westrand, London; telephone, 2630, Gerrard.
2. FINANCIAL SECRETARY AND BUSINESS MANAGER (Advertisements, etc.), *Articulate*, Westrand, London; telephone, 2630, Gerrard.
3. MEDICAL SECRETARY, *Medisecra*, Westrand, London; telephone, 2630, Gerrard. The address of the Irish Office of the British Medical Association is 16, South Frederick Street, Dublin (telegrams: *Bacillus*, Dublin; telephone, 4737, Dublin), and of the Scottish Office, 6, Rutland Square, Edinburgh (telegrams: *Associate*, Edinburgh; telephone, 4361, Central).

QUERIES AND ANSWERS.

POST-HERPETIC ITCHING.

DR. LEONARD J. KIDD (London, N.W.3) writes: Let "Puzzled" (p. 662) try the following powder internally: Calcii sulphidigr. i.10, sacch. lactis gr. j, sacch. albi gr. v; misce; triturate well and flavour with oil of cinnamon. Take one powder after each meal. Sulphide of calcium often acts as a mild laxative.

DR. J. E. CHALMERS (Castleton, Grosmont, Yorkshire) writes to say that he finds calomel ointment (argumentum hydrargyri subchloridi B.P.) most efficacious in skin affections where there is concomitant inflammation and itching.

INCOME TAX.

"A. W. B." inquires as to the following car transactions. In 1913 he bought a 10 h.p. German car for £250; in 1921 he sold it for £120 and bought an 11 h.p. car for £425.

* Assuming that a 10 h.p. car of similar quality to the original one would have cost £400 in 1921, the amount allowable is £400 less £120 = £280.

"RITZ" sold his old car for £100 and bought another for £475; the old car was of an American make not now obtainable.

In determining the amount of the allowance, it is desirable to ascertain the present-day cost of a car of similar make and power. Supposing that to be £r, the amount of the allowance due is £r - £100 or £475 - £100, whichever is the lower.

"SENEX" retired from the Navy in March, 1919, and from October, 1919, to October, 1920, received fees from the Ministry of Pensions on which he has paid tax at 6s. in the £. For the year to October, 1921, he expects to receive less.

* It is arguable that the fees should be assessed under Schedule E on the amount receivable for the current financial year; alternatively, if they are assessable under Schedule D on the average of the past receipts, "Senex" can still claim to put

the average aside in favour of the current year's basis, that right existing so long as the first year forms part of the applicable three years' average. In either case, therefore, "Senex" need not pay a second time on the higher fees receivable for his first year's civil work.

"F. A. W." inquires what is a fair allowance for the "expenses incurred on the board, lodging, and laundry of one maid during the year 1920."

* Obviously the cost will vary very much owing to personal or professional circumstances. We are inclined to suggest the figure of £50 as one which in normal circumstances could be shown to be reasonable.

"Z. Z." derives some income from property in the Isle of Man; he pays income tax to the island authorities, but has recently been assessed for 1919-20 and 1920-21 to British income tax on the same income. He asks, Is this correct?

* Yes; the income tax is chargeable in this country, notwithstanding the payments already made in the Isle of Man, which forms a different fiscal entity. On the other hand, in making the assessment to the British tax an allowance should be made for the previous payment, so that the effect of the double taxation is reduced. The figures supplied suggest but do not prove that this has been done by the assessors. If necessary, that point should be cleared up with the local inspector of taxes.

LETTERS, NOTES, ETC.

NAEVI IN CHILDREN.

DR. G. THOM, writing with reference to the treatment of naevi by electrolysis described as slow by Mr. Duncan Fitzwilliams (BRITISH MEDICAL JOURNAL, April 23rd, p. 605), recommends the following method; among its advantages, he says, is the fact that the tissues are in a more or less similar condition, so that a uniform dose can be given. A preliminary injection of adrenaline and novocain into the surrounding tissues is given; the naevus blanches and its outline, therefore, must be carefully marked beforehand. The negative electrolysis needle is inserted into this contracted vascular tissue and the positive pad moved about the margin of the blanched area. The negative needle is partly withdrawn and reinserted in varying directions and depths through the same inlet. The length of time, the amount of pressure, or the number of millampères, can be disregarded. The novocain obviates the deep anaesthesia necessarily required when even the slightest movement must be eliminated, as in treatment about the orbit.

SMELLING SALTS TO PREVENT SEA-SICKNESS.

DR. ROBERT A. FLEMING (Edinburgh) writes: It may be of interest to medical men to offer my experience with regard to the value of ordinary but strong smelling salts in obviating sea-sickness.

When meditating over the pallor which invariably precedes the stage of sickness it occurred to me that if this pallor could be prevented the nausea might pass off. In a case of ordinary faintness smelling salts constitutes a well known remedy. It is almost certain that the brain or part of it becomes anaemic in sea-sickness, and that stimulation with the smelling salts has a definite effect in rectifying this.

The only writer who has suggested a remedy of the kind was Loomis, who advised amyl nitrite, and he suggested that this should be inhaled repeatedly whenever the feeling of vertigo was felt. Most people, however, find that amyl nitrite produces a more or less severe and disagreeable headache.

When crossing the Channel some years ago I tried strong smelling salts on two fellow passengers with wonderful results although the sea was very rough. A second test was made on a friend who had to cross in winter from Aberdeen to Lerwick. He was a very bad sailor and greatly dreaded the journey. Although the weather was very bad he managed to be the only passenger able to be down at every meal, and he told me that the smelling salts saved him many times over. Since then I have often recommended my simple remedy with benefit. As I do not find any reference to this cure, or rather preventive treatment, in any of the works I have consulted which deal with sea-sickness, I send this short statement hoping that it may be of use to some of my fellow practitioners.

ALKALINE DENTIFRICES AND THE DECREASE OF DENTAL CARIES.

MR. J. SIM WALLACE (London, W.) writes: Your correspondent "Nestor" (May 7th, p. 692) seems to suggest that the great increase in dental caries may be due to the use of alkaline dentifrices, but it would appear from various figures and reports, including the report of the Chief Medical Officer of the Board of Education, that there has not been a great increase in the disease. Indeed, it is important to note that there has been a distinct decrease in dental caries recently.

This has no doubt resulted very largely from the restricted use of sugar, more especially in the form of sweets. The suggestion that the decrease may be due to the more limited consumption of the vitamin known as "fat-soluble A," resulting from the high prices and scarcity of milk, cream, butter, and animal fats during the war, is hardly likely to be considered a probable explanation at present. Butter and flesh foods are both detergent in their effects upon the teeth, and the decrease in dental caries would have been considerably greater had these foods been cheap and plentiful during the war. Fruits and vegetables which are somewhat acid are much better than acid mouth-washes for keeping the teeth clean and free from caries, and I only advocate an acid mouth-wash as part of a quite second-rate and secondary method of securing physiological cleanliness of the mouth.

MR. GUY W. E. HOLLOWAY (London) writes: The answer to "Nestor's" inquiry in the JOURNAL of May 7th, p. 692, as to the reason why dentists still order milk of magnesia as a mouth-wash is threefold: First, the teaching of the hospitals and dental schools where the subject of preventive medicine is either ignored or the entirely wrong alkaline treatment is still taught; secondly, although Dr. Pickereil's essay on prevention was awarded the Cartwright Prize by the Royal College of Surgeons and published in 1912, strenuous war work subsequently prevented men taking up the new treatment; thirdly, what should be everyone's work is no one's work, and many dentists have taken the view, rightly or wrongly, that preventive treatment comes within the doctor's province. On the other hand, doctors look upon it as part and parcel of the dentist's work. Consequently, it has been ignored, with the result that wholesale extractions of teeth have taken place which might have been avoided.

HERPES AND VARICELLA.

DR. A. S. HENDRIE (Holt, Norfolk) writes: On February 23rd I saw a schoolboy who was suffering from intercostal herpes. Eighteen days afterwards a boy in the same house developed varicella, and a boy in another house also. This latter boy attended classes with the boy who first developed varicella. On November 8th, 1920, I saw a boy with slight herpes, and sixteen days afterwards, a case of varicella appeared. In one of these cases, during the acute stage of the eruption, the larynx was obviously affected, well-marked croupy symptoms being present. On the eighth day of the disease apical pneumonia on the right side appeared, terminating favourably by crisis eight days afterwards. For the relief of itching I have found nothing so effective as the application of tincture of iodine to each vesicle once or twice daily as suggested by Dr. Chas. Corben of Cheam. Moreover, as he points out, the duration of the disease is materially shortened, and there is an absence of scarring.

A MEDICAL MISSIONARY WANTED.

DR. WILLIAM ODELL (Torquay) writes: In *Mercy and Truth* for May is an editorial appeal for a doctor to start pioneer medical missionary work in Kavirondo (north-east of Victoria Nyanza Central Africa). "The Government offer of £3,950 for buildings, equipment, and staff will lapse if we are unable to find a doctor before June 30th of this year." Dr. J. H. Cook, C.M.S., Salisbury Square, who has worked for twenty-one years at Mengo Hospital, Uganda, will be very glad to be brought into touch with any doctor who is able to consider the possibility of offering for this great work.

VACANCIES.

NOTIFICATIONS of offices vacant in universities, medical colleges, and of vacant resident and other appointments at hospitals, will be found at pages 33, 36, 37, 38, 39, and 40 of our advertisement columns, and advertisements as to partnerships, assistantships, and locum tenencies at pages 34, 35, and 36.

THE following appointments of certifying factory surgeons are vacant: Evesham (Worcester), Mullingar (Westmeath), Wath-on-Dearne (Yorks, West Riding), Clwt y Bont (Carnarvon), Washington (Durham).

SCALE OF CHARGES FOR ADVERTISEMENTS IN THE BRITISH MEDICAL JOURNAL.

	£	s.	d.
Six lines and under	0	1	0
Each additional line	0	1	6
Whole single column (three columns to page)	7	10	0
Half single column	3	15	0
Half page	10	0	0
Whole page	20	0	0

An average line contains six words.

All remittances by Post Office Orders must be made payable to the British Medical Association at the General Post Office, London. No responsibility will be accepted for any such remittance not so safeguarded.

Advertisements should be delivered, addressed to the Manager, 429, Strand, London, not later than the first post on Tuesday morning preceding publication, and, if not paid for at the time, should be accompanied by a reference.

NOTE.—It is against the rules of the Post Office to receive *postestante* letters addressed either in initials or numbers.

A Clinical Lecture

ON

ACUTE INFECTIVE ARTHRITIS.

DELIVERED AT GUY'S HOSPITAL.

BY

F. J. STEWARD, M.S., F.R.C.S.,

SURGEON TO THE HOSPITAL.

On June 16th last, in consultation with Dr. Montgomery of Bromley, I saw a little girl, aged 4, with a swollen left knee.

The history was that the child had always been healthy and robust, but just recently had not seemed quite herself, also she had been bothered with "heat spots," some of which had been scratched and had become pustular. A week previously she complained that her knee hurt her when she was being put to bed. The next morning the knee was more painful. Dr. Montgomery saw her and found the knee a little swollen and slightly tender, but she moved it freely. The temperature was 100 F. No other joints were affected. A splint was applied and small doses of sodium salicylate ordered. During the succeeding days the knee swelled more and became more painful, the temperature rose to 100 or 101, her general condition was not so good, and sleep was much disturbed by pain.

When I saw her, on the seventh day, she was looking ill and tired. The knee was tense and obviously contained fluid. It was tender, but not extremely so, and, moreover, the thigh was distinctly swollen. There was no swelling behind the knee, and no tenderness on pressure over femur or tibia. Attempts at moving the knee obviously caused pain.

Here, then, was a child with a single swollen, tender, and painful joint associated with pyrexia and general illness, and becoming progressively worse. These are the signs and symptoms of acute arthritis, which in this case was clearly not rheumatic, as no other joints were affected, and the administration of salicylates had produced no improvement. It was therefore probably due to a pyogenic infection.

Now let me remind you of the ways in which a joint may become infected. They may be arranged conveniently in four groups:

1. *From the exterior*, due to accidental and gunshot wounds.

2. *By spread from neighbouring parts*, especially in cases of acute infection of one of the bones forming the joint.

3. *By metastasis* from an infective process in some other part of the body. In one case I shall mention later there was an infected graze over the knee, in another the source was probably a septic tonsil.

4. *In general blood infection*. Here infection of one or more joints is, of course, a frequent occurrence.

Now this child had no wound of the joint, and there was no evidence of infection of either of the bones or of any other part near the joint. There was therefore no reason to suspect a spread of infection to the joint from the neighbouring parts, and there was no evidence of a general blood infection. The case, therefore, did not belong to Group 1, 2, or 4. There were, however, the spots that had been scratched, which constituted a very possible source for a metastatic infection. I therefore placed the case in Group 3.

In such circumstances clearly the next step was to confirm the diagnosis by means of the exploring syringe. This I advised, but as it was desired that Dr. Still should see the child, there was a delay of a few hours. Then, under an anaesthetic, I drew off a syringe of thick yellow pus.

When a joint becomes infected by pyogenic organisms, the brunt of the attack is borne in the first instance by the synovial membrane, which puts up for a time a very stout resistance. This primary stage in the process is of the very first importance, for, while it lasts, suitable treatment usually results in complete recovery.

After a while, however, the infection spreads to the other structures forming the joint, and also to the parts beyond the joint, so that cartilage and ligaments are destroyed, and the joint becomes converted into an abscess cavity. Further abscesses form outside the joint and spread in various directions. If, as the result of treatment after this stage has been reached, the patient survives, the best result that can be hoped for will be a

joint more or less completely ankylosed, and very possibly dislocated, owing to destruction of ligaments.

In the case we are considering, then, much depended upon whether the resistance of the synovial membrane had been so far equal to the occasion or not, and it was necessary that such treatment should be adopted as would aim at supporting that resistance in every way possible.

I want particularly to lay stress upon this very remarkable local characteristic of the synovial membrane of a joint which enables it to deal with infection probably even more efficiently than the peritoneum. War experience emphasized this, for results clearly show that the best way to treat a joint infected by a bullet or piece of shell or clothing is to remove the foreign body, cleanse the joint so far as possible, close the wound, and let the synovial membrane do the rest. In a large majority of the cases treated in this way a perfect cure resulted.

Now the synovial membrane may be assisted in the exercise of its functions by treatment, that is to say:

1. By letting out the pus. By so doing the blood supply to the synovial membrane, which must be greatly interfered with by the direct pressure of the pus, will be restored, in addition to getting rid of the local and general poison.

2. By keeping the limb at rest by the application of a suitable splint with extension. The extension is very necessary in order to overcome the pain and so render the patient comfortable and able to rest. Without it the muscles tend to spasm, which results in pressure between the inflamed and painful joint surfaces, and also in those sudden terrible pains which occur just as the patient falls asleep and the contracted muscles relax. In the knee-joint the best appliance is a Thomas knee splint which is suspended in a cradle, extension being obtained by means of a weight in the ordinary way.

3. By the injection of antiseptics into the joint. The necessity for this is by no means certain, and, although it has been held to be of great service by some surgeons, its value must be, to a large extent, problematical. The substances most favoured are a 2 per cent. solution of formalin in glycerin, the use of which was strongly advocated by Murphy, and ether, which has also been largely used, especially during the war.

But, in order that this treatment may have a chance to succeed, it must be applied in good time, and before the barrier imposed by the synovial membrane has been seriously broken through, otherwise the results are likely to be disastrous.

This implies a correct diagnosis at the earliest possible moment, and, to this end, I wish to insist upon the extreme importance of the use of the exploring syringe without delay, in order to clinch the diagnosis whenever you have occasion to even suspect that a joint is infected. By this means, and this means only, will the best results be obtained.

I treated the case we are considering on these lines. An incision was made on the inner side of the patella and a large quantity of thick pus evacuated. The joint was then thoroughly washed out with warm mercury bichloride solution of a strength of 1 in 4,000. It was noted that the synovial membrane was quite pallid when first seen while the pus was being evacuated, but very quickly became intensely engorged with blood, showing, as I have mentioned, that the intra-articular pressure had interfered with the free supply of blood to the part. The capsule of the joint was then closed with catgut sutures, the skin wound sutured, and dressings and splint applied.

During the next two days the child was markedly better, the temperature was only slightly above the normal, she took food well, and made no complaint of pain. The bacteriological report upon the pus was that a pure culture of *Staphylococcus aureus* had been grown from it.

When I saw the child again, on the third day, the joint was less tender and the thigh less swollen, but as there was some fluid in the joint I explored it. The syringe, however, only withdrew a small quantity of clear fluid, slightly blood-stained, which was very remarkable in view of the condition only three days before; it showed how well the synovial membrane was doing its work. Nevertheless, in order that we should feel that we had done everything that could be done, whatever happened later, I then injected into the joint 2 c.cm. of 2 per cent. formalin in glycerin.

Subsequent progress was perfectly satisfactory, except that two small stitch abscesses formed, each accompanied by a slight degree of pyrexia. The joint remained a little swollen for some time, but no more fluid formed and the child's general condition rapidly improved. The extension was kept on until all swelling had disappeared—that is, until the end of July.

After this the child was taken to the sea wearing a back splint. This was kept on for two months, when I found the knee normal in appearance and without heat or tenderness. Flexion was perfectly free and smooth through about thirty degrees; after that there was slight resistance. I ordered the limb to be massaged, the splint to be gradually discarded, and the limb used more and more, and although I have not seen the child again, I understand that the knee now moves quite freely and painlessly and is completely recovered.

I wish to draw attention to a few further points regarding this case. The first is that from the time the joint was emptied of pus, and the extension applied, the child never again complained of pain. Consequently she slept well and soon regained her appetite, factors contributing in no small degree to her recovery.

The next point is that the organism in this case was *Staphylococcus aureus*. This is, I think, unusual, but is in conformity with the view I expressed that the infection came from the skin pustules. Of three other metastatic cases that I shall describe, the organism in one was a streptococcus, in the other two no organism was found. The third point is that the disease was not extremely acute, for the joint was not opened until the seventh day and yet recovered completely. This is what usually happens in metastatic cases, and is to a less extent, perhaps, true of some other cases. For instance, I had under my care in France an officer who had had a fragment of shell lodged in the back of the upper end of the tibia. When he came under my care he had been wounded a week, and there was a good deal of fluid in the knee-joint, but it was not particularly painful and not at all tender. He was seen by two consultants, both of whom expressed the opinion that the fluid was not pus and that the joint should not be interfered with. However, I thought it wiser to explore the joint, and on so doing found the fluid to be pus.

The next case had reached a slightly more advanced stage before the joint was explored, nevertheless the result is perfect, as you will see.

Joan C., aged 4 months, was admitted to Guy's Hospital on January 7th, 1920, with a swollen right elbow of several days' duration. The child was obviously ill; the temperature was raised and the elbow swollen, tender, and clearly extremely painful on attempted movement. Mr. Slesinger operated upon the case for me. The joint was opened, and a quantity of pus let out. After washing out the joint the incision was closed and a splint applied.

The child was better for several days, then the temperature again rose, the arm became more painful, and a fluctuating swelling appeared in the arm, the elbow itself remaining normal in size. The swelling was explored, and found to contain thick pus, but on free incision no connexion with the elbow-joint could be detected, and after drainage for a few days there was no further trouble. The bacteriological report upon the pus from this case states: "No growth obtained after several plantings."

The subsequent history was uneventful, and I am now able to show you the child ten months after the joint was opened. You see that she looks quite healthy, and that the arm and elbow move perfectly freely in all directions. In fact, but for the two scars, it would not be possible to say that the arm had ever had anything wrong with it.

This case differs from the first in that an abscess developed outside the joint. But you will note that with the formation of this abscess there was no refilling of the joint with pus, neither was any connexion between abscess cavity and joint cavity discovered at the second operation. It is quite clear, therefore, that there was no direct continuity, but that the periarticular abscess had originated in some other way. Examination of portions of synovial membrane from infected joints has proved that micro-organisms may be present in the subsynovial tissue without any massive ulceration or perforation of the synovial membrane having taken place. A proportion of the organisms in an infected joint therefore evade the attentions of the synovial membrane and escape into the tissues beyond, where they are either destroyed or cause the formation of pus, as the case may be. This, then, explains the formation of an abscess in this child's arm although

the synovial membrane was not destroyed. The third case is very similar.

A boy, aged 7, was admitted into Guy's Hospital on October 8th, 1920. Eight days previously a brick, thrown at him by another boy, struck him on the left knee and grazed the skin. Next day the knee began to swell and to become painful, and during the succeeding days the pain and swelling increased.

On admission to hospital there was a small septic graze over the front of the left knee; the joint was tense with fluid, very tender, and extremely painful on any attempt at movement; the temperature was 100°, and the boy looked very ill. Under an anaesthetic the exploring syringe drew pus, so the joint was opened, washed out with mercury bichloride 1 in 4,000, the wound closed, and a Thomas knee splint with extension applied.

During the next two days the boy was clearly better, but his temperature remained high (103°), and when, on the third day, I found the knee again swollen, and the bacteriological report stated that a pure culture of *Streptococcus longus* had been grown from the pus, I thought it wiser to explore the joint once more. The result, however, was perfectly satisfactory, the fluid withdrawn being clear serum, slightly blood-stained. In view of the bacteriological report and the high temperature, 15 c.c.m. of antistreptococcal serum were given subcutaneously. After this the boy improved, although the skin incision suppurated slightly, but on October 23rd—that is, fifteen days after the first operation—the temperature shot up to 103° again, and some swelling appeared in the thigh. Four days later it became clear that there was an abscess in the thigh; an incision was made and several ounces of pus evacuated, but no communication between the abscess cavity and the knee-joint, which was now almost normal in size, could be found.

From this time progress was satisfactory, and the boy left the hospital in good health on December 8th, but still wearing a splint.

Unfortunately, no culture was made from the septic graze over the knee, but I feel sure that this was the source of the streptococcal infection of the joint.

Here, as in the last case, an abscess formed outside the joint without any direct connexion, and, in fact, after the joint itself had practically recovered. It was no doubt due to spread of infection through the synovial membrane.

To recapitulate the main features of these three cases: they all were children, the arthritis in all was metastatic in origin; they all illustrate the remarkable power of the synovial membrane of a joint to deal successfully with infection; they all show the value of using the exploring syringe without delay, and they were all treated by washing the joint out through a free incision, complete closure of the incision, splinting, and extension. Finally, they all recovered—two with complete restoration of function; the third is still under treatment.

The next case presents quite a different picture.

A little girl, aged 8, was admitted to hospital after three days' illness, with a brawny tender swelling involving the lower half of the right thigh. She was extremely ill, with very rapid pulse and temperature 104°. A diagnosis of acute osteitis of the femur was made, and she was operated upon immediately. A large subperiosteal abscess was opened, and the lower part of the bone, which was found to contain pus, was rapidly laid open and packed lightly with gauze. The next day the child was better, but on the following day she was delirious, and the knee-joint was found to contain pus.

The limb was immediately amputated through the middle of the thigh, but she died the following day, abscesses in the myocardium and early pericarditis being found *post mortem*.

This case illustrates the infection of a joint from a neighbouring bone, and you will note the extreme virulence of the disease in comparison with the metastatic cases I have already described. Further, you will observe that as soon as it was found that the knee-joint was infected the limb was amputated. This course was adopted because the child was already so extremely ill that it was quite clear that she would not be able to deal with an infected joint in addition to her other troubles. In these circumstances an immediate amputation offers the only chance of saving the patient's life, and is occasionally successful in doing so.

In all the cases I have described there were very definite symptoms and signs that drew immediate attention to the affected joint, so that there was, at any rate, no possibility of failure to recognize the seat of the trouble. This, however, is not always the case, for there is another quite definite clinical type of infective arthritis—a condition which might well be described as "quiet" arthritis, since there are no acute symptoms and no pus formation. In fact, the condition is often undiagnosed and unsuspected until the patient is convalescent. Then a joint, more often than not the hip, is found to be disorganized, fixed and very probably dislocated.

I had hoped to show you a boy illustrating this condition, but he was not able to come. He was in hospital three years ago with acute osteitis, and during a long and serious illness he developed, no one knew exactly when, an arthritis of the hip which resulted in a pathological dislocation. So far as is known there was never any swelling or other sign to call attention to the hip-joint, and no pus formed, or, at any rate, no abscess was opened. Nevertheless, there is a dislocation that is easily made out, and the x-ray plate shows that the joint has been completely disorganized.

Such a condition may well be termed "quiet" infective arthritis owing to the absence of any definite occurrence to call attention to the condition. As in this case the hip is the joint most usually involved, possibly owing to its deep position, but other joints may in the same way become affected without attracting attention, especially in patients lying desperately ill from a blood infection. The knowledge of the possibility, as illustrated by this case, will no doubt help to emphasize the importance of keeping a watchful eye on the joints in all cases of acute infective illnesses.

ACUTE INTESTINAL OBSTRUCTION.

A SERIES OF 282 CASES.

BY

E. R. FLINT, F.R.C.S.,

SURGICAL TUTOR AT THE GENERAL INFIRMARY, LLIDPS.

THE object of this paper is not to detail the frequency of the various kinds of acute obstruction, or to show the relative proportions in males and females and the ages at which they occur, etc. These points have all been worked out in papers by many authors. It is mainly to the subject of treatment my remarks will be directed.

The operative mortality of acute obstruction is generally held to be somewhere between 40 and 50 per cent. in a series of cases. There is no doubt this large death rate is attributable in no small degree to operation being performed on cases sent into hospital very late in the disease, but I hope to show that by making use of the results revealed by recent experimental work it is possible to reduce this mortality very materially.

This series of cases is 282 in number and a consecutive series upon which I have operated in a period of two years. They were taken as they came, without any attempt at selection as regards suitability for operative purposes, and are a very fair sample of the type received into any large hospital.

There is no doubt that there has been much improvement of recent years in the matter of early recognition of serious abdominal cases of all descriptions, but acute intestinal obstruction has still a very heavy mortality, which is due partly to delay and partly to the very vital character of the organs concerned.

The mortality in this series is 15.6 per cent. As will be seen from the table below I have included strangulated external herniae and acute obstruction from carcinoma. It is not usual, perhaps, to classify these with the ordinarily accepted cases of acute obstruction. Leaving these out of account, there were 70 cases, with a death rate of 28.5 per cent. This is still too great a mortality, but a considerable improvement.

Classification of Cases and Mortality.

	No. of Cases.	Deaths.	
		No.	Per cent.
External herniae	170	18	10.5
Bands and adhesions	39	10	25.6
Intussusception	26	10	38.4
Carcinoma of intestine	42	6	14.5
Volvulus	2	0	
Internal hernia	1	0	
Thrombosis of mesenteric vessels ...	1	0	
By gall stone	1	0	

I included external herniae because the pathology is essentially the same as that of many cases of strangulation by band, and the carcinoma cases are included because they were admitted as emergencies, and in many of them the only diagnosis possible before operation was acute intestinal obstruction.

Let us consider first the experimental work, the application of which, I hold, is of the greatest importance in the treatment of acute ileus.

Wilkie¹ has shown that the contents of the intestine above an acute obstruction are very toxic and teeming with bacteria, and that the mucosa protects the organism against a toxæmia until it becomes seriously damaged by great distension, demonstrating the important selective and neutralizing function of the intestinal mucosa. The work of McLean and Andries² fully confirms this.

Further confirmation of the late absorption of the toxic contents of the intestine was established by Wilkie in a series of experiments on cats, in which he produced an acute obstruction and then injected into this obstructed part the toxic contents from the intestine of cats which had died of an acute obstruction. If toxic absorption had killed the first series, and the second started out with its obstructed intestine filled with the toxic material from the first series, symptoms of toxæmia should very quickly supervene; the results, however, were the same as in the first series. If, then, toxæmia is not responsible for the symptoms of acute ileus until a late stage, to what are the early symptoms due? Wilkie's experiments on cats show that early death in acute strangulation is mainly due to shock with its associated splanchnic paresis and depleted systemic circulation (internal loss of fluids); that peritonitis plays an important part only after some twenty-four hours, when the vitality of the mucosa has been considerably interfered with. Death in high intestinal obstruction—as opposed to strangulation—is due to shock also, but in this case the fluid is largely lost externally through excessive vomiting, as well as into the tissues, and in the absence of strangulation the vitality of the mucosa persists much longer. Death in low obstruction is much later in its occurrence, owing to reabsorption of much of the intestinal secretion poured out into the upper reaches of the intestine.

Among the effects of shock are a concentration of the blood and increased viscosity due to loss of plasma from an abnormal permeability of the capillaries. Severe pain, which causes an outpouring of adrenaline from the suprarenal glands, can produce these evidences of shock, as shown by Elliott, Cannon, and others. And it is not too much to suppose that the severe pain, probably peritoneal in origin, caused by acute obstruction of such vital parts as the intestines, is enough to bring about this outpouring of adrenaline and the production of shock. Later the shock will be kept up by toxic absorption, for, as Dale and Laidlaw³ have shown in their experiments with the poison histamine, shock may be produced, and this substance acts apparently in the same way as many products of protein digestion and bacterial activity.

In cats Wilkie has demonstrated the immense value of subcutaneous saline infusion. In obstruction of the distal part of the duodenum in a cat the animal vomits large quantities of bilious fluid, is very thirsty, and loses weight rapidly, dying usually within seven days of onset. If, however, the animal be given daily subcutaneous infusion in large quantities with 5 per cent. dextrose, not only will it show immediate improvement, but life will be prolonged for many days beyond that of a control animal.

Another point of much importance is brought out by Wilkie, and that is that toxic absorption from the intestine below an obstruction, after the relief of this, has been greatly exaggerated; indeed his experiments scarcely permit of its occurrence at all. The intense danger, however, of the least soiling of the peritoneum with this highly toxic material is forcibly emphasized. He concludes that peritonitis plays little part in the causation of death in simple acute obstruction until the late stages, unless accidental soiling occurs at operation. I shall revert to the practical surgical application of these experiments after considering those of another experimenter—namely, Crile.

Crile's⁴ work is mainly concerned with shock, and as shock is closely associated with the cause of death in acute ileus, his experimental work is quite pertinent. He has elaborated a very perfect technique for the prevention and lessening of the harmful effects of severe and prolonged stimulation. The principle of this anoci-association is the blocking off of the entry of the stimuli to the higher centres of the nervous system, both physical and psychical stimuli. This is accomplished by the free use of morphine, local anaesthesia, and gas and oxygen as a general anaesthetic. Morphine lessens the conductivity of the nerve paths, whereas strychnine, which is often given to patients suffering from shock, to "back them up," as it is said, increases conductivity, and so enables the noxious stimuli to get to the nervous system more easily. Morphine should only be given in the absence of cyanosis; this symptom, according to Crile, indicates a state of acidosis, and morphine impedes the efforts of the tissues to rectify it. Morphine should be given in repeated doses at half-hourly intervals until the respirations fall to 12 or under. The ideal method is, of course, to get the morphine in first, before the painful stimuli begin; naturally this is not possible in acute ileus, but even so the effect of the drug is to cut off much of the shock producing stimulation.

Local anaesthesia, when efficiently performed, cuts off all stimuli arising in the blocked area. The reason for using nitrous oxide is this: Crile found that this anaesthetic so protected the central nervous system that very few or none of the characteristic changes which are produced in the cells by excessive stimulation appear when stimulation is applied during the administration of this anaesthetic; whereas during ether or chloroform narcosis the same changes occur in the cells, and with nearly as great ease as when the patient is conscious of pain.

In my series of cases these principles were deliberately utilized. I did not, however, always use local anaesthesia, and open ether was the general anaesthetic always employed. Gas and oxygen has this practical objection: that many anaesthetists find much difficulty in obtaining a sufficient relaxation, and this is particularly impeding the surgeon in such a condition as obstruction, where the distended intestines are often extremely difficult to control even under the most favourable disposition of affairs.

It is evident, therefore, that it is not in the best interests of the patient merely to operate at the earliest moment. Certainly, broadly speaking, the sooner the patient is brought to operation the better, but there is usually an interval between deciding to operate and the commencement of the actual operation—an interval of perhaps an hour or two at the least, during which measures should invariably be taken to assist the resources of the patient, both against his disease and against the additional shock of the approaching operation.

In addition to the usual measures of warmth, washing out the stomach, and so on, there are two of the first importance—namely, saline infusion and morphine.

First, with regard to saline infusion. This should be given at the rate of at least two pints an hour before operation, and continued during and after operation at about half this rate. Five per cent. glucose should be added, and it will usually have to be given subcutaneously. I think saline infusions are absorbed more quickly when given by the rectum, but in acute ileus they are not always well retained. It is common knowledge that in deep shock saline has a very transient effect; nevertheless, even then it produces temporary improvement in the patient's condition. The earlier it is given the better the effect. Dale and Laidlaw suggest the addition of calcium ions, as this drug has a specific action in reducing the permeability of the capillaries. I have tried calcium chloride in 0.05 per cent. strength, and have not been able to convince myself that it is any more efficacious than normal saline. I am not sure that whole blood would not be better, but, so far, I have not been able to satisfy myself that this is the case in acute obstructions.

The second measure to use is morphine. As soon as it has been decided to operate the sooner morphine is given the better. To an adult $\frac{1}{4}$ grain may be given at once, and repeated in doses of $\frac{1}{8}$ grain, or just over, every half-hour until the respirations fall to about 12. I usually give $\frac{1}{2}$ grain to quite young children with intussusception for example, and repeat it. Morphine should be continued after operation and the patient be allowed gradually to come out from its influence during the succeeding twenty-four hours.

Pituitary extract is another useful drug. It exerts a prolonged and general contraction of the circulatory system, and thereby diminishes the total capacity of this system, and mitigates the effect of deficient blood volume. After operation it may help to produce muscular contraction of the intestine. Eserine is another drug which may be used for this latter purpose.

For the last ten minutes of the operation the patients were made to breathe pure oxygen through an inhaler. This seemed to better their condition, and I am not sure it would not be a good thing to keep this up for some time after, in much the same way as is done for cases of gas poisoning and others.

As to the operation itself, the earlier in the case it is performed the simpler it will be, and in the more leisurely manner may it be done. As a rule, the cases are not seen at this desirable stage, and quick operating is usually required, and at times is absolutely essential; but rapid, inaccurate, and rough work is responsible for many deaths. Repeated indecisive handling of the same parts is to be avoided. Precision, with gentleness and the minimum of exposure, are the essentials for success. Plenty of warm and moist towels to cover intestine, which may unavoidably

prolapse, or be purposely turned out, and more than usual care to avoid soiling, are points which require particular attention.

The most useful incision is a right para-umbilical one, splitting the rectus muscle. In some cases a large intestine growth will be found, and colostomy or typhlotomy be required. The central incision is then used for the purposes of exploration only, and stitched up before the artificial anus is made through a separate opening. If the intestine be found viable nothing remains to be done but release it, either by freeing the adhesions, or, if the obstruction be by band, this will need dividing and ligaturing close to both its attachments.

It may be found that the line or lines of compression are anaemic, or even have cut through into the intestinal lumen, the rest of the gut being returnable with safety. In this case it is wiser to bury this area than attempt a resection. Any suturing which has to be done requires infinitely more care than is necessary in suturing under non-obstructive conditions. It is almost certain that the serous stitch occasionally penetrates into the lumen of the gut, and is not attended by disaster, but in obstructed and tightly distended intestines leakage occurs at such a point, with an inevitably fatal result.

Enterotomy, merely to drain the intestine at the time of operation, is never necessary, and is a very risky procedure.

It often happens that there is a sero-sanguineous fluid in the peritoneal cavity in cases of strangulation. This should be mopped out, and no drainage employed in the absence of offensive smell. This fluid may be present for forty-eight hours before it becomes infected. If there is even a faint faeculent odour about it a tube should be inserted into the pelvis through a stab wound. Any such smell means also that the intestinal wall is incompetent at some point, and would be an indication for not merely returning the intestine into the abdomen.

Whether the intestine is viable or not requires experience to determine in many cases. When the colour is a dirty grey or greenish-grey, or the brown of a dead leaf, and the gut feels like wet blotting-paper, it is quite certain that recovery is impossible; it is equally certain that it will recover when the colour is red, or even black, if there is any resistance to touch in the walls. It is in the intermediate stages that difficulty may arise. I think more reliance may be placed on the fingers than the sight in these cases. If the walls feel limp and offer no sensation of firmness to the fingers—it is, perhaps, too much to call it resistance—then it is not likely that recovery will occur. The mortality of all cases not requiring resection in this series was 9.3 per cent.—that is, 236 cases, with 22 deaths.

When it has been decided that resection, or anything more than merely freeing the intestine, is necessary, the utmost care should be expended in isolating the field with protective appliances. Gauze swabs wrung out in hot saline are carefully packed in all round, and over these, protecting them and the edges of the wound, are placed mackintoshes; these consist of a sheet of dental rubber stitched into a thin gauze covering. These serve two purposes—they prevent in a most efficient manner the entrance of septic material from the damaged intestine; and, secondly, they keep in the natural moisture and warmth much better than does a pervious material like gauze alone.

Having protected the field one proceeds to deal with the damaged gut. In most cases this will mean resection. After removing the necessary amount of intestine it is as well to empty some of the contents from the proximal segment by inserting Moynihan's tube. This makes suturing much easier. A lateral anastomosis is the best method of union to employ, because it is safer and there will be much difference in calibre between the two ends. Enterostomy should only be done in the very desperate cases. It is not always easy to know exactly where the opening is being made, and if high in the intestine the patients waste rapidly. Also it is necessary, as a rule, to do the second operation within a few days of the first, when the patients are not fit to endure much manipulation, and it is just these cases which are exceedingly difficult to deal with. Consequently the mortality is a very high one after the second operation. Nevertheless, some desperate cases have been now and again saved by this measure.

One more practical point, which I have found of great use, is the finding of the obstruction. Much needless exposure, and therefore much avoidable shock, is prevented by first examining the caecum and terminal ileum. Distension of the caecum, of course, means obstruction in the large intestine, and the condition can be dealt with as below. But if one finds a piece of collapsed ileum, this should be followed towards the stomach until the distended intestine is met. The examined part is returned as finished with. This method only requires about 2 in. of gut to be out of the abdomen at any one moment.

It should always be kept in mind that there may be more than one band causing obstruction; in my series there were two such cases.

In this series there were 46 cases which required resection; 11 of these were intussusceptions, with 9 deaths. This is in marked contrast with the reducible cases, of which there were 15 with 1 death. The youngest successful resection was in a girl just under 3 months old. The mortality of all resections was 45.4 per cent.

Of the cases in Group 2, 12 were the result of bands and adhesions due to the presence of tuberculous mesenteric glands, 9 to bands not of tuberculous origin, 4 to Meckel's diverticulum acting as a band, 1 to the appendix acting as a band, and 13 to adhesions resulting from previous operations—2 of these occurred during the first few days after appendicectomy with drainage. It is interesting to note that when adhesions caused the obstruction, this appeared to result from a rotatory effect given to the intestine rather than from kinking.

The volvulus cases were both of the caecum—one was merely reduced and fixed, the other required resection.

The internal hernia was through a hole in the mesentery, and whether of congenital origin or not was not determined, though there was no history of injury.

The case of thrombosis of the mesenteric vessels required resection of some 4½ feet of small intestine, apparently about the lower jejunum, and was successfully accomplished.

In the gall-stone case the stone was impacted in the lower ileum, and was removed, the intestine being sutured.

Of the external hernia cases there were 170, with 18 deaths, a mortality of 10.5 per cent. Fifty were inguinal, with the strangulation at the external abdominal ring in at least 40—it was only found at the internal ring in 5; there were 3 deaths. Ninety-eight were femoral, with 11 deaths. Eighteen were umbilical, with 4 deaths.

Resection was performed only once in the inguinal cases, 18 times in the femoral, and 4 times in the umbilical.

It is interesting to note how much more serious to the vitality of the intestine is a femoral hernia, probably due to the much tighter ring.

Most of the femoral hernia cases were operated on from the abdomen through the outer part of the rectus sheath. It was necessary to free the sac from below, and Gimbernat's ligament was also usually divided from below. The peritoneum was efficiently protected, and first the gut reduced and dealt with from above, and later the sac was turned inside out into the abdominal wound. There is a distinct advantage in this method in two ways—first, it gives much more satisfactory access in case resection be necessary, and secondly, a radical cure is more easily effected, for the neck of the sac can be stitched up into the abdominal wound and the inner end of Poupart's ligament can be stitched to Cooper's ligament under direct observation on the upper side of the pubic arch. Also, if thought necessary, a piece of the rectus muscle can be carried across to Cooper's ligament, though I have never found that this was required. I have never seen a case recur after this method, though it is probably claiming too much for it to expect never to see a recurrence.

As regards the carcinomata cases, it usually happens that a positive diagnosis is only made after an exploration by a right para-umbilical incision. It is unfortunately true that most cases of carcinoma of the colon are only recognized either after giving rise to acute obstruction or on the discovery of a tumour. When the patient is desperately ill it is better to do typhlotomy at once, but when possible an exploration is advisable to ascertain the position of the growth and the feasibility of subsequent removal. If the growth is in the sigmoid and irremovable a colostomy should be done, but if removable, typhlotomy.

There is no doubt that the danger of sepsis at the second operation is thereby much reduced. A growth higher up in the colon requires either typhlotomy or, when in the descending colon or left half of the transverse colon, transverse colostomy may be done: if, however, there is a removable growth in these parts I believe it is always better to do typhlotomy.

Carcinoma of the rectum, of course, can be diagnosed before operation, and in any case requires a colostomy.

REFERENCES.

- ¹Wilkie, *Experimental Observations on the Causes of Death in Acute Intestinal Obstruction*. ²McLennan and Andries, *Journ. Amer. Med. Assoc.*, November 2nd, 1912. ³Dale and Laidlaw, *BRITISH MEDICAL JOURNAL*, March 24th, 1917. ⁴Crile, *Anoci-association*. Crile and Lower. ⁵Flint, *Lancet*, May 31st, 1919.

ABDOMINAL PAIN:

ITS MECHANISM AND CLINICAL SIGNIFICANCE.*

BY

A. E. MAYLARD, B.S.LOND., F.R.F.P.S.GLASG.,
F.R.S.EDIN.HONORARY CONSULTING SURGEON TO THE VICTORIA INFIRMARY,
GLASGOW.

POSSIBLY no symptom in the whole realm of disease is of greater interest and of wider distribution than that of pain. To the uninitiated it is often considered a mystery, more perhaps from its moral aspect than from its clinical. To those of us who regard it in the light of an indication that Nature is conveying information of considerable physiological and clinical importance in the elucidation of functional and pathological disorders, it becomes a subject of the greatest significance. As a study in itself, pain embraces an accurate knowledge of certain anatomical and physiological facts, as well as a comprehensive investigation into the morbid processes of disease. The subject is naturally a very wide one, and in the short hour at my disposal I can only deal with it in a very restricted way. My remarks, therefore, are to be limited to the discussion of pain as it is manifested in the abdomen.

For us, as clinicians dealing with the symptoms of disease, the most practical part of all these considerations about the nerve supply of the various parts of the body is that which concerns the ultimate distribution of the spinal nerves; for it is by means of these that we gain a great deal of our clinical information regarding the various seats of disease, and sometimes also the particular nature of the disease. It behoves us, therefore, to remember very accurately the final distribution of every nerve that leaves the brain and spinal cord to end in some part of the body. Take, as an example, the sixth thoracic intercostal nerve. In its course between the sixth and seventh ribs it gives off close to the spine its posterior primary branch, which is distributed to the skin between the lower angles of the scapulae; then, about the middle of the intercostal space, from before backwards, it gives off its lateral cutaneous branch, which ends in the skin on the side of the chest a little below the level of the lower end of the scapula; and, finally, the nerve ends in the sensory organs contained within the skin of the epigastric region at its upper part.

Here the lecturer showed by means of diagrams the various anatomical connexions between the sympathetic nerve system, the spinal cord, the nerves, and the viscera.

Clinical Significance of Pain.

Let us turn our attention to the practical application of the knowledge by which communications take place between the brain and spinal cord and the various parts of the body, and see how it works out in the diagnosis and treatment of disease. As a first clinical example we may take pain felt in the epigastrium, the side, and the inter-scapular region in the case of chronic gastric ulcer. The nerve supply of the stomach is, of course, by means of the two vagi and the sympathetic solar plexus, the latter being intimately connected with the coeliac plexus, which in its turn receives nerve branches from the subsidiary plexuses that are directly associated with the stomach. When, then, ulcer of the stomach causes pain to be felt in

* Abstract of a lecture delivered to the students of Queen Margaret College, University of Glasgow.

the parts before mentioned, the lines of communication between the seat of disease and the centres of pain are those that have already been anatomically traced; thus, from the great solar plexus, the large splanchnic nerves pass upwards to the sixth thoracic sympathetic ganglia, fibres from which pass onwards to the cells in the posterior cornua of that segment of the cord which also receives fibres from the sixth thoracic intercostal nerve. Now, inasmuch as these spinal nerves have at their terminals sensory organs capable of producing the impression of pain it follows that this pain will be experienced in those parts where these sensitive organs are located; and those in the case of the sixth intercostal nerve will be in the epigastrium, the side of the chest, and between the shoulder blades. Pain thus occurring not at the actual seat of disease, but at some other place, often at a considerable distance, is called a "referred" pain. Nearly all pains felt in connexion with abdominal disease connected with the viscera are of this "referred" character.

To illustrate this further, let us take some other examples: those, for instance, connected with the presence of gall stones and those associated with the existence of calculi in the kidney. Here we have two organs closely related anatomically to each other, with many symptoms also much alike, but in which the acute colicky pains are widely different in their seats of distribution. To explain this divergence of two organs so closely related and so similarly affected, we have simply to refer to the anatomical distribution of the nerves respectively associated with each viscus in order to ascertain how the affected viscera cause the symptom to become manifested in a distant part of the body. In the case of gall stones, the first link in the chain is the hepatic sympathetic plexus. This plexus is, of course, connected with the coeliac plexus, itself intimately associated on the one side with the great solar plexus, and on the other side with the phrenic ganglion, which is situated in the diaphragm. It has already been shown in the case of the stomach how the solar plexus by its somatic connexions causes pain to be felt in the epigastrium. It is the connexion of the hepatic plexus with the phrenic ganglion situated in the diaphragm that explains the right shoulder pain; for this ganglion, through the medium of the phrenic nerve, is brought into relation with the fourth cervical nerve that distributes branches over the shoulder.

Another interesting example of "referred" pain is that connected with acute appendicitis. In this disease the initial seizure is frequently felt in the umbilical region before the pain settles down into the right inguinal region. The sequence of events is not difficult to follow. The inferior mesenteric plexus supplies the ileo-caecal section of the intestinal canal, and therefore the appendix also; but this plexus, through the medium of the aortic plexus, connects with the solar plexus, so that a communication is set up with the large splanchnic nerve. This nerve connects, through the corresponding sympathetic ganglia, with the fifth to the ninth or tenth thoracic intercostal nerves, whose final distribution is the epigastric and umbilical regions, where are the sensory end-organs that give rise to the feeling of pain. That pain is later felt directly in the right iliac region over the actual seat of disease is probably due to the inflammatory involvement of the parietal peritoneum, which is an extremely sensitive structure, and readily causes pain when overstimulated by any unnatural agency.

I am anxious now to present the picture in another form. In our practical clinical work we do not begin with a knowledge of the organ diseased and explain the presence of the pain; we do just the reverse. We investigate the nature and situation of the pain, and from these data seek to discover the disease. I am going, therefore, to ask you to examine a specific instance of a patient suffering from pain, say, in the epigastric region, and to seek with me to differentiate its clinical significance. It should be remembered, in the first place, that we are dealing with a "referred" pain, not with pain that is dependent on some local mischief in the abdominal parietes, but with that which is the result of influences transferred from some distant organ or tissue. Our first natural thought connected with pain in this region would be that it might be of gastric origin, but as there may exist no other symptoms suggestive of disease or functional derangement of the stomach, what other causes could give rise to it? I think that if you have followed

me in all that I have already indicated regarding the way in which the various nerve influences are conveyed you will readily understand how it is possible for certain sensitive cutaneous areas to be the focalizing seats of pain indicative of disease in more than one organ or tissue. This fact is very plainly demonstrated in the case of epigastric pain. You will remember how many abdominal viscera are associated through the medium of their respective sympathetic plexuses with the great central solar plexus, and how this plexus again, by means of the large splanchnics, is brought into connexion with the sixth and other intercostal nerves; so that, for instance, any acute disease of the pancreas—to mention only one viscus—would be as likely to cause pain in this region as an acute gastric disturbance.

What I wish more particularly to draw your attention to is the fact that not only can epigastric pain result from influences derived from diseased viscera, but that the involvement of any link in the chain between its two terminals—the cutaneous structures and the viscus—can equally evoke pain in this region. Before the splanchnic afferent nerves can excite the somatic afferent nerves both must more or less come into association with the cells of the posterior cornua. If, then, these cells become unduly excited by disease in the spinal cord, which directly involves them, a precisely similar result ensues as if they had been overstimulated by influences brought to them by the splanchnic nerves. This is what happens in patients suffering from *tuberculous dorsalis*, who frequently complain of acute seizures—crises—of epigastric pain. But, further, suppose the sixth intercostal nerve is involved in any part of its course between the spinal cord and its ultimate seats of distribution, pain will similarly occur in the epigastric region. This is precisely what happens in some cases of pleuropneumonia and in tuberculous caries of the spinal column. It is extraordinary how many mistakes have been made where epigastric pain has arisen from these causes. In the early stages of our abdominal work I fear that there were few surgeons who would not have had to confess to errors of judgement in this respect, more particularly in the cases of inflammation of the lungs and pleura.

I might take up other cutaneous areas where "referred" pain is felt, the cause for which could be attributed to more than one source. I think, however, that I have said enough to excite your interest, and indicate to you the important clinical fact that we must never stake our diagnosis on one solitary symptom however prominent and significant that symptom may be. Possibly you will be struck more forcibly with the value of adopting this method of clinical research in seeking to trace the cause of a "referred" pain if I instance a somewhat puzzling case that I recently encountered. It was a patient who had acute appendicitis, and in whom the most dominating symptom was a severe and continuous pain over the right shoulder. It led to the natural inference that the cause of the trouble might be gall stones. But the deciding factor in arriving at a correct diagnosis was the rigidity of the muscles in the right iliac and lumbar regions, and the pain produced on deep pressure in these parts. The abdomen was therefore opened as for appendicitis in the right iliac region. The diseased viscus was found lying upwards under the ascending colon. It was free, but from the existence of free turbid fluid in and around the region of the appendix there was evidently a certain amount of peritonitis. This I think is the probable explanation of the "referred" pain felt in the shoulder. The peritonitis in the region of the appendix extended to the liver and the under surface of the diaphragm; this caused an involvement of the phrenic ganglion, and as the phrenic nerve connects this ganglion with the fourth cervical spinal nerve, the pain over the shoulder is at once explained. The fact that the removal of the appendix and the subsidence of the peritonitis completely cured the pain sufficiently suggests that the explanation given was probably the correct one.

Variations in Manifestation.

It is interesting to consider the various conditions that affect both the nature of the pain produced, its extent, and its degree of severity. As clinical factors of diagnostic significance they are of considerable importance. As regards the nature of pain, we are almost entirely at a loss to explain why, for instance, a pain should be of a

"burning" character, "cutting," "stabbing," or "gnawing" like toothache. A pain of the intermittent "colicky" or "gripping" type does, however, admit of a more or less satisfactory explanation, for it indicates an unduly violent effort on the part of involuntary muscles to expel some foreign or excessively irritative material, or to overcome obstruction. We encounter this type of pain in chronic intestinal obstruction, and also in the presence of renal and biliary calculi. With this exception, however, the other characters of pain seem to be inexplicable; and from the fact that the same disease may cause different types of pain we are unable—at least at present—to attach much clinical importance to these varied manifestations.

When we come to consider pain from the point of view of degree or severity we are brought up against some very interesting problems. The first of these concerns the individual regarded as a collective organism. Some patients have a much more sensitive nervous system than others, so that what may be easily endured by one may be almost beyond toleration by another. These normal constitutional variations are always worthy of careful consideration. Then we have the effect of certain blood conditions which may have an augmentative action on the sensitiveness of the system to pain. In fever, for instance, the increased temperature may unduly excite those cells in the spinal cord or brain which are concerned in the production of pain; and these cells may also be similarly affected in certain anæmic conditions of the blood—possibly, from impoverishment, the result of deficient or defective nourishment, they are more susceptible to stimulation.

With regard to the distribution of pain, there are equally some very interesting problems to solve. To give an instance or two of what I particularly refer to: Why should pain in appendicitis sometimes be felt in the left iliac region? Why should stone in the kidney on one side give rise to pain on the other—a reno-renal reflex as it is termed? You will remember that, when discussing the causes of "referred" pain, I indicated how it was in all likelihood explained: that certain cells in the posterior cornua of the spinal cord, lying in close contact with other cells, when stimulated, transferred that stimulation to those other cells, and thereby caused an impression to be produced which accounted for the particular location of the pain. Now, these cells in the one cornua are connected by nerve filaments with similar cells in the other cornua; and if we assume that, for some unexplained reason, the cells in the opposite cornua are more sensitive to exciting influences than those on the side of the disease, we get the impression produced that the disease is on that particular side.

Let me instance a case that came under my observation many years ago—in the pre-x-ray days. The misfortune which followed the operation performed could not very well happen now when, by means of photography, we are so able to assure ourselves as to the existence or not of a stone. The patient referred to complained of pain in the right lumbar region, strongly suggestive of renal calculus. The kidney was cut down upon and explored, but no stone was found. The patient died four days after the operation from suppression of urine, and at the necropsy a stone was found in the left kidney.

It is but a further extension of the explanation that I have just given to understand how it is that pain may be widely diffused or distributed and not "referred" to any particular part or region. For if owing to undue excitability of all the cells in the spinal cornua more than those normally stimulated become involved, you can readily appreciate how much more extensively diffused must be the area of pain felt. Thus it sometimes happens that when these cells are in an unduly excitable condition, or when, perchance, the stimulus itself is of so acute a nature that it oversteps the limitations of even normal cells, the pain resulting from disease of an abdominal organ may not be limited to any particular part of the epigastric, umbilical, or hypogastric regions, but be more or less diffused over two or more of these regions.

I have not time to touch upon many other points which the study of abdominal pain presents, and this short hour has only permitted me to deal with the fringe of my subject. If I have done no more than to excite your interest I feel sure that that awakened interest will prove useful to you in the future pursuit of your profession.

THE PHYSIOLOGICAL COST OF MUSCULAR WORK.

BY
LEONARD HILL, M.B., F.R.S.,
AND
J. A. C. CAMPBELL.

In the article published in this JOURNAL (May 7th, 1921, page 669) Waller and De Decker record results giving the physiological cost of muscular work of colliers, shoemakers and others as measured by the exhalation of CO₂. We are carrying out experiments of a similar nature with Dr. E. Schuster's modification of Martin's bicycle ergometer—doing 13,000 kg. m. of work per hour—using both the method employed by the above observers and the standard Douglas bag method, in which both the CO₂ output and oxygen use are measured, and the heat loss calculated therefrom, as recommended by Cathcart.¹ As the results we have obtained with these two methods rarely agree, we consider that the possibility of limitation of Waller and De Decker's method should be emphasized before deductions other than the broad difference between light and heavy work are drawn from their results. We consider that a source of error is the short duration—thirty seconds—of the period for obtaining the sample of expired air. We have found that the volume of CO₂ expired while at rest or at work varies greatly during consecutive half-minute periods (Table I), and also that the CO₂ exhalation per second obtained in a thirty-second sample is rarely similar to that obtained per second during a four-minute period (Table II).

TABLE I.—Consecutive Half-minute Samples of Expired Air. (Subject J.A.C., unaccustomed to use of mouthpiece.)

Date.	Resting.			After working 1 hour on ergometer.		
	Sample.	Heat Loss.*	CO ₂ (c.cm. per sec.).	Sample.	Heat Loss.	CO ₂ (c.cm. per sec.).
April 1, 1921	1st	0.49	1.5	1st	4.76	15.7
	2nd	0.76	2.1	2nd	4.25	13.7
	3rd	1.10	4.1	3rd	4.00	12.6
April 4, 1921	1st	1.50	3.8	1st	4.49	13.1
	2nd	1.45	3.7	2nd	4.52	13.6
	3rd	1.24	3.3	3rd	4.00	13.8

* The heat loss in all tables is in terms of millicalories per square centimetre per second, Cathcart's method for calculation being used. On April 4th J. A. C. had become more accustomed to the use of the mouthpiece.

TABLE II.—Half-minute and Four-minute Samples. (No food taken. Subject C.P., accustomed to use of mouthpiece.)

Date		Half-minute Sample.		Four-minute Sample.	
		Heat Loss.	CO ₂ (c.cm. per sec.).	Heat Loss.	CO ₂ (c.cm. per sec.).
April 25, 1921	After 2 hours' work on ergometer	5.8	17.7	4.6	12.7
	After 3 hours' work on ergometer	6.3	19.2	—	11.0
	After 4 hours' work on ergometer	5.4	16.4	4.2	11.2
May 4, 1921	After 2 hours' work on ergometer	3.3	8.3	5.1	13.6
	After 4 hours' work on ergometer	4.8	12.7	4.9	13.2

Another factor on which these observers do not apparently place sufficient emphasis is the influence of food. Benedict and Carpenter have shown that the ingestion of all kinds of food in any amount results in an increment of metabolism.² We have obtained similar results. We think that there is a danger of a reader misinterpreting the charts and tables as presented by Waller and De Decker. In nearly all their cases the cost per hour of "practically maximal and constant" work appears to increase as the day proceeds. Johansson's curves of diurnal temperature

and CO₂ output of a normal individual living a normal life vary together. This, we suggest, is due to the influence of food, and that if this be excluded the CO₂ cost per hour of this constant work remains the same at any period.¹ Benedict and Cathcart's well-known experiments on a trained bicyclist in the post-absorptive condition, show clearly that severe constant work requires the same amount of CO₂ exhalation per second at the end of three hours of work as during the first hour.⁴ Using a bicycle ergometer and four-minute samples of expired air, we have obtained similar results (Table II). It is only after taking food (Tables III and IV) that our subjects show a rise of CO₂ exhalation similar to the increase shown in Waller and De Decker's charts.

TABLE III.—Showing Effect of Food whilst Resting.
(Subject C.P., resting. Ten-minute samples of expired air.)

Date.		Heat Loss.	CO ₂ (c.cm. per sec.).
April 20, 1921	One hour after food ...	1.13	3.2
March 30 ..	" " " " ...	1.16	3.0
April 20, 1921	Two hours after food ...	1.43	3.7
March 30 ..	" " " " ...	1.47	4.0

TABLE IV.—Showing Effect of Food whilst at Work.
(Subjects C.P. and L.H., working on ergometer. Four-minute samples of expired air.)

	Heat Loss.			CO ₂ (c.cm. per sec.).		
	L.H.	C.P.	C.P.	L.H.	C.P.	C.P.
Two hours before food	3.3	4.9	4.23	12.7	12.3	11.8
One hour before food	3.5	4.8	3.88	11.9	12.0	11.1
Food taken.						
One hour after food ...	3.9	4.2	4.9	13.1	11.5	12.6
Two hours after food	4.2	5.1	4.86	14.9	14.3	14.7

It is well known that a fatigued or uncomfortable subject carries out a given amount of work at a greater cost than when normal, but it does not seem reasonable that the colliers and shoemakers under consideration are so unskilled and of such poor calibre as to show signs of fatigue after a couple of hours' constant work, when this work is of the degree specified.

REFERENCES.

- ¹ *Journal of the Royal Army Medical Corps*, November, 1918.
² Publication No. 261, Carnegie Institute, Washington, 1918. ³ Lusk, *Science of Nutrition*, Third Edition, p. iii. ⁴ *Muscular Work*, p. 65. The Carnegie Institute, Washington, 1913.

COMPARATIVE SYSTOLIC BLOOD-PRESSURE READINGS IN THE ARM AND LEG IN AORTIC INCOMPETENCE.

BY

O. K. WILLIAMSON, M.D.CANTAB., F.R.C.P.LOND.,

PROFESSOR OF MEDICINE ELECT, UNIVERSITY COLLEGE, JOHANNESBURG;
 PHYSICIAN TO THE CITY OF LONDON HOSPITAL FOR DISEASES OF THE CHEST; LATE ASSISTANT PHYSICIAN TO THE WESTMINSTER HOSPITAL.

THE higher systolic reading by the blood-pressure instrument in the leg compared to that in the arm, when both are at the level of the heart, appears to have been so generally accepted as a characteristic and even diagnostic sign in aortic incompetence that it would seem to serve a useful purpose briefly to review the subject, so as to consider whether or not this conclusion is a sound one, and, if not, what are the fallacies which underlie it.

Leonard Hill, with the co-operation of Martin Flack and W. Holtzmann,¹ first made the observation that in all cases of aortic regurgitation there is a marked difference between the reading of the systolic arterial pressure in the arm and in the leg, that in the leg being the higher, the observation being taken in recumbency. These observers further state that "when such patients are lying quiet in bed this difference is a diagnostic sign of aortic regurgitation." They found that the difference of pressure is not abolished by the method of oscillating the pressure up and down near the obliteration pressure. The explanation which they give of the difference is that the "big systolic waves are conducted better

down the leg arteries, these being slightly thicker and more contracted and rigid." In a later paper Hill and Rowlands² brought forward additional cases illustrating the same phenomenon. H. A. Hare came to similar conclusions to those of Hill.³ H. D. Rolleston⁴ confirmed the observation, and among other conclusions found that the difference between the maximum systolic blood pressure in the arm and leg is most marked in uncomplicated and compensated aortic regurgitation, but "is much less marked in aortic regurgitation when the compensation is failing, and in cases of combined aortic regurgitation and mitral disease"; further, that "in recent aortic regurgitation before compensation is established the difference is slight or may be absent." J. R. Murray⁵ published records showing similar differences. J. Heitz⁶ recorded observations on 51 cases concerning this phenomenon, and whilst finding it in the majority of cases, disagrees with Hill as to its constancy. He, moreover, draws attention to the important fact that the difference is to be found in other classes of cases. He says: "L'élévation de pression dans les artères tibiales peut être constatée chez la plupart des sujets atteints d'insuffisance aortique" . . . but "elle peut manquer dans un certain nombre de cas." Again: "L'élévation de la pression systolique aux membres inférieurs peut se constater avec une certaine fréquence chez des sujets hypertendus et non atteints d'insuffisance aortique." He has also found it in abdominal aortitis. He concludes that the sign "ne présente donc pas de valeur diagnostique absolue."

Such a difference of pressure readings may certainly occur in other conditions than aortic incompetence. Thus I have observed it in high-pressure cases associated with arterio sclerosis,⁷ and, according to Clifford Allbutt, this observation was first made by Volkmann.⁸ Further, MacWilliam has found the same difference in some patients with sclerotic arteries.

The conclusions drawn from my own observations are as follows:

1. Although higher systolic readings in the leg than in the arm appear to occur in the majority of cases of aortic incompetence, there is a large minority in which they do not obtain.

2. There is no evidence that such cases, when they do exist, are the result of the actual aortic incompetence rather than of the commonly associated conditions of hypertonic contraction or hypertrophy of the muscular coat, with or without accompanying sclerotic changes, conditions which also occur independently of aortic incompetence.

3. In support of the arterial explanation of such differences is the fact that the large majority of cases of the series in which the arteries were thickened showed the difference, being a much larger proportion than obtained in the total number of cases of the series (all of which had aortic incompetence); and further, that in the adult cases of aortic incompetence, nearly all of which had thick arteries, the phenomenon was more than twice as common as in the children, in none of whom were the arteries thickened.

4. If due to the aortic incompetence it would seem reasonable to suppose that the difference of reading should show some relationship to the degree of incompetence, which for practical purposes may be considered as measured by the pulse pressure. No parallelism, however, exists between these arm-leg differences and the corresponding degrees of pulse pressure.

5. In the few cases in which this was tried, in the majority the difference of pressure was abolished by repeated recompression, a fact decidedly in favour of the arterial explanation. (In cases of a higher leg reading than that in the arm in arterial disease it has been frequently found that the difference is abolished by such recompression.)

Method of Observation and Apparatus.

This paper being based on observations which were spread over many years, different instruments were used, but these were one or other of the modifications of the Riva-Rocci method—namely, Stanton's instrument, Oliver's compressed air haemomanometer, Martin's instrument, and that of French.

The armlets used were at least 12 cm. breadth, except in a few of the children, in whom an armlet of 10 cm. was used for the arm observations. When not otherwise stated, the armlet for the lower extremity was placed on the calf. In the few cases in which the thigh was used for compression a specially broad armlet (18 cm. broad) was used. All readings were taken on reducing the pressure after obliteration of the pulse. Unless otherwise stated, the tactile method was the one adopted. In the readings by this method the radial artery was used for the upper extremity, the dorsalis pedis or posterior tibial for the

Cases.

	Sex.	Age.	Diagnosis.	Arm Reading.	Leg Reading.	Difference.	Pulse Pressure.	History.	Remarks—Arteries, Pulse, etc.
Adults.				mm.	mm.	mm.			
1	M.	39	Aortic incompetence, (?) abdominal aneurysm	*173	208	35	60 mm. approx. §	Rheumatic fever, syphilis	Arteries thickened; pulse collapsing.
2	M.	53	Aortic incompetence, dilated aorta	209 184 184 135	234 200 237 135	25 16 53 0	89 mm. approx. §	—	Arteries markedly thickened; collapsing pulse.
3	M.	55	Aortic incompetence, dilated aorta	*182	265	83	106 mm. approx. §	—	Arteries markedly thickened; pulse collapsing.
4	M.	53	Aortic incompetence	195 155	200 190	5 35	—	Rheumatic fever (recent)	Arteries thickened; pulse collapsing.
5	M.	42	Aortic incompetence	142	139	-3	—	—	Arteries thickened; pulse collapsing.
6	F.	39	Aortic incompetence	198 208 237	208 242 243	10 34 36	72 mm. †	—	Arteries thickened.
7	M.	32	Aortic incompetence and stenosis	118	215	97	67 mm. †	§ Syphilis	Arteries somewhat thickened; pulse somewhat collapsing; artery full between beats.
8	M.	16	Aortic incompetence and stenosis, mitral incompetence	80	110	30	—	—	Arteries normal.
9	M.	40	Aortic incompetence and mitral stenosis (?)	143	131 (thigh)	-12	—	—	Arteries normal; pulse collapsing; temperature at or nearly 100° F.
10	M.	31	Aortic incompetence	*143	148 (thigh)	5	99 mm.	No past illnesses	Temperature about 100° F.
11	M.	40	Aortic stenosis and incompetence	128 154 auditory	135 (thigh) 180 (thigh) auditory	7 26	95 mm.	—	Arteries markedly thickened.
12	M.	43	Aortic incompetence; myocardial degeneration	160 approx. *187 approx.	180 approx. 270 approx.	20 approx. 85 approx.	—	Rheumatic fever and syphilis	Pulse collapsing; arteries markedly thickened; last observation caused pain.
13	M.	37	Aortic incompetence and stenosis	120 120	100 80	-20 -40	40 mm. approx.	—	Arteries markedly thickened; pulse slightly collapsing; artery full between beats.
14	M.	31	Aortic incompetence and stenosis; mitral incompetence	145	145	0	115 mm.	Rheumatism and chorea	Arteries thickened; pulse collapsing.
15	M.	39	Aortic stenosis and incompetence, mitral stenosis and incompetence	115	170	55	63 mm.	—	Arteries somewhat thickened; pulse slightly collapsing; artery full between beats.
16	M.	70	Aortic incompetence	210 auditory 190 auditory	250 (thigh) auditory 228 (thigh) auditory	40 38	130 mm.	—	Arteries thickened.
Children.									
17	M.	12	Aortic incompetence	*95	120	25	35 mm. approx.	—	Arteries normal; pulse perhaps slightly collapsing.
18	M.	15	Aortic incompetence, mitral stenosis and incompetence	133 119 114	122 128 114	-11 9 0	76 mm. approx.	—	Arteries normal; pulse collapsing.
19	M.	10	Aortic incompetence, mitral stenosis and incompetence	*122	122	0	58 mm. approx.	Rheumatic fever	Arteries normal; pulse rather collapsing; artery full between beats.
20	M.	13	Aortic stenosis and incompetence, mitral stenosis and incompetence	*107	97	-10	61 mm. approx.	—	Arteries normal; pulse slightly collapsing; artery full between beats.
21	M.	10	Aortic incompetence and stenosis	125	145	20	70 mm.	—	Arteries normal; pulse collapsing; artery full between beats.
22	M.	11	Aortic incompetence	*135	125	-10	—	—	Arteries normal.
23	M.	13	Aortic incompetence and stenosis, mitral stenosis and incompetence	110	135	25	—	—	Arteries normal.
24	M.	12	Aortic incompetence and mitral incompetence	104 *110	108 90	4 -20	82 mm. approx.	Chorea	Arteries normal. At first observation, pulse not collapsing, compensation fair; at second observation, pulse collapsing, compensation good.

* Indicates that the arm and leg observations were not made synchronously. † Indicates that the difference was abolished by recompression. ‡ Auditory method, point of disappearance of sound. § Method of maximum oscillation for diastolic.

lower. Dr. George Oliver's auditory tambour attached to a binaural stethoscope was used for the auditory readings. The tambour for the arm readings was placed at the bend of the elbow, and for those on the lower extremity at the popliteal space.

In the auditory readings the point of appearance of the audible throb was taken as the systolic reading, and unless otherwise stated the point at which the loud note becomes suddenly dull before disappearing was taken as the diastolic reading. In a few of the early auditory readings the diastolic index was taken as the point of disappearance of the sound (Cases 6 and 7), and in the first observations (Cases 1, 2, 3) the approximate visual method of the point of maximum oscillation was used. The pulse pressure was taken as the difference between the systolic and diastolic readings in the arm.

Corresponding observations on the leg and arm are recorded on the same line, and, unless otherwise stated, were made synchronously, one manometer being connected by means of a T-shaped tube with both armlets. Observations of any case on different lines were made on different days. The patients were at rest in the recumbent position, and the results are recorded in millimetres of mercury.

Details.

This paper is based on observations of 24 cases of undoubted and, indeed, well marked aortic incompetence. In 14 of these a difference obtained in the arm and leg readings. In the 10 remaining cases there was either a higher arm than leg reading or there was no difference in favour of the leg reading. Two of the cases which did not show the difference had temperatures of 100° F. or nearly 100° F. at the time of examination. Rolleston,⁴ in his observations, found that in two cases temperatures of 101.4° F. and 100.4° F. respectively caused the difference to diminish greatly or to disappear. It is possible, therefore, that the slight degree of fever may have explained the absence of the difference in my two cases, so that I have thought it well to exclude these two cases from the list. This leaves 22 cases to be considered, of which 14 were adults and 8 children of from 15 years downwards. Of these 22 cases, 14 showed the difference, leaving 8 in which the sign did not obtain.

It is to be noted that 10 out of the 14 cases showing the difference had thick arteries (all except Nos. 8, 17, 21, and 23), or of all the 13 cases of the series having thick arteries 10, or all but 3 (Nos. 5, 13, and 14), showed the difference, a much larger proportion than that which obtained in the total number of cases (14 out of 22) all of which had, of course, aortic incompetence. Further, in the 14 adult cases 11 showed the difference, whereas by contrast it was observed only in 3 of the 8 children, in none of whom were any arterial changes found. These two points suggest very strongly the arterial origin of the phenomenon.

In regard to the relationship of the degree of pulse pressure to the arm-leg difference, there was no correspondence between the two. Taking the 6 highest pulse pressures, in 4 of them, Nos. 2, 3, 11, and 16, there was a marked difference, whilst, on the other hand, in the 2 others, Nos. 10 and 14, no appreciable difference was found. In 3 out of 5 cases in which it was tried, the difference of pressure was abolished by repeated recompression, which again is as we have seen in favour of the arterial explanation, and is at variance with Hill's finding aortic regurgitation.

It will be seen, if my results be compared with those of the various writers on this subject that they are similar to those of Heitz, but differ from those of the others, and it may be pointed out that Heitz's conclusions appear to be based, to judge from the published records, upon a considerably larger number of cases than those of the other observers.

Whilst of course I freely acknowledge that the limited number of cases upon which the present paper is based is insufficient to form the basis of general dogmatism, it is certainly quite sufficient to show that the phenomenon is nothing like a constant sign of aortic regurgitation. Finally, I would submit with some insistence that future observations should include in each case a note upon the condition of the arteries, an omission as to which has deprived past records of much of their value.

REFERENCES.

- ¹ *Heart*, vol. i, p. 73, 1909-10. ² *Ibid.*, vol. iii, p. 219, 1911-12. ³ *Therapeutic Gazette*, 1910, Third Series, xxxvi, p. 457. ⁴ *Heart*, vol. iv, No. 1, 1912. ⁵ *BRITISH MEDICAL JOURNAL*, March 28th, 1914. ⁶ *Paris Méd.*, 1917, xxiii, 112-122. ⁷ *Clinical Observations on the Influence of the Vessel Wall on So-called Arterial Blood-Pressure Readings*, *Proc. Roy. Soc. Med.*, May, 1909. ⁸ *Haemodynamik*, Leipzig, 1850.

An Address

ON

ELEMENTARY PSYCHOLOGY IN GENERAL HOSPITAL TEACHING.

DELIVERED BEFORE THE ULSTER MEDICAL SOCIETY,
MARCH, 1921.

BY

WILLIAM CALWELL, M.D.,

PHYSICIAN, ROYAL VICTORIA HOSPITAL, BELFAST; MEDICAL OFFICER
IN CHARGE, CRAIGAVON HOSPITAL FOR NEURASTHENIC PENSIONERS,
BELFAST.

In August, 1920, I was instructed to examine a woman aged between 60 and 70, and report on her mental and general condition; she had had a stroke in 1912 and another two years later. She was bedridden. Both arms and legs were strongly flexed, the knees nearly touching the hips, the heels the hips, and the arms were crossed over the abdomen; she had no control over bowel or bladder; her articulation was very defective, resembling an exaggerated mumbling lisp; orientation for time and space was hopelessly poor; she said she was 43, and that it was the year 1909; her memory was quite unreliable, her ideas extremely limited; she knew nothing about her affairs except that she got a certain sum a week from a deceased sister, and had been robbed of her furniture, and in making these statements she exhibited tearful but short-lived emotion.

I had no difficulty in making a report. In a subsequent letter I was asked whether I could give an opinion as to the time during which this patient had been incapable of managing her affairs, and whether there was any ground for forming an opinion as to what the mental capacity of the patient was likely to be after the seizure in 1912.

In trying to answer these questions I realized that my knowledge was very limited. It could be put into two statements: (1) After a stroke there is mental weakness, which may be of so slight a degree as to be unnoticed, or may amount to well marked secondary dementia, where the patient has returned to second babyhood; and (2) that there is a question how far aphasia meant intellectual incompetence. I answered that it was impossible to form a reliable opinion.

So I turned to our textbooks and to what medical literature I had time to consult. Some simply mentioned the question of examination of the mental condition of our patients, some gave a rough outline, a few lay emphasis on the "cerebral" features of arterio-sclerosis, by which I presume they meant "mental" or "psychic" features. This is the "arteriopathic dementia" of the alienist. It is interesting and instructive to note how even some of our best textbooks do not refer, or refer in an inadequate manner, to the difference between cerebral physiology and psychology. The textbooks on mental diseases are not included in this statement. Many of our manuals of medicine and monographs on the diseases of the nervous system consider elaborately the questions of cerebral pathology and of aphasia; to illustrate the latter subject the pages abound with diagrams which, rather unfortunately, recall from our unconscious memory the forty-seventh proposition of the first book of Euclid, and we are apt to associate with these diagrams the same childlike faith in the definiteness of proof and of absolute reliability that we learned in our boyhood to associate with the famous right-angled triangle; normal or morbid psychology is not touched upon.

Charcot, in his classical clinical lectures, takes up a very interesting attitude: the study of cerebral haemorrhage, he says, forms an introduction to the study of diseases of the encephalon. The sudden tearing of the tissue realizes in some degree the simplicity sought in experiments on animals, but he omits the mental condition. His further lectures were unpublished.

Our later textbooks and manuals on insanity do supply the want; whether in an altogether satisfactory manner or not is a legitimate subject of debate, but the effect of this separation is that the student and most medical men do not attempt to make even an elementary psychological examination of a patient, unless this patient is actually insane, and then only so far as to ascertain whether insanity exists or not. But a patient's mentation is a function of his brain; this function is continually being carried on; it is a function—not perhaps from a vital point of view, but certainly from a social point of view—which is incontestably the most important, and it should not be relegated to an odd half-dozen of lines.

Cerebral physiology is yet very incomplete, and so we should teach the elements of psychology to the student as part of the clinical examination of the most important function. At present it is left to the native wit of the doctor to size the mentality of a patient. Should we not train him in scientific methods? Would we give up our scientific and regular, orderly, means of physical examination because the native wit of Hippocrates enabled him to do so much? Let us rather correlate cerebral physiology and psychology to make as complete an examination of the functioning of the nervous system as our present knowledge allows, and obtain practical aid in the examination of our patients.

An examination of some of our excellent manuals on clinical examination and case-taking showed the same deficiency; the reflex movements of the big toe were strongly in evidence, but the powers of memory, of ideation, the depth of emotion, the occurrence and kind of dreams, and the bias of mind, the powers of expression, of calculation, were passed by unnoticed or barely noticed; Hutchison and Rainy in their *Clinical Methods* give a page on which is printed a special scheme for cases presenting mental symptoms drawn up by Henry Head for use in the wards of a general hospital. A student, however, is told in other places to practise examination on healthy lungs, hearts, urine, etc. Why should he not practise a little normal psychology, and so be better fitted to examine and recognize psychological abnormalities when they present themselves?

A student should have a certain amount of both normal and morbid psychological training before going to the asylum; he will be able to benefit by his training in that

institution; and, in his final undergraduate year and ensuing years of practice, he will be less apt to confuse psycho-neurosis with malingering, congenital defect or bodily disease, and so be enabled to give the proper and right treatment.

A revolution is taking place in this subject of psychology; it may be said to have begun with Freud of Vienna roughly at the commencement of this century. Freud was a physician and was led to his theories by the study of mental affections, but his theories concern a universal problem of psychology. It would be impossible even to attempt a brief explanation of Freud's "unconscious mind," "suppression," "censorship," "conflict," "psycho-analysis," "interpretation of dreams," etc. We should be led into an arid discussion of priorities and interpretations, but undoubtedly much merit and noteworthiness should be attached to his mechanism and the nature of his "mental conflict." Side by side with this psychological change is the great advance in cerebral physiology due to the work of Henry Head and his school in London. Thirdly, we have the enlightened and progressive study of the psycho-neuroses during the war and afterwards. And, lastly, we have the endeavour to correlate all three, as will be seen in the book, *Instinct and the Unconscious*, lately published by Rivers of Cambridge; he tries to show the various aspects of the psycho-neuroses as biological reactions. I shall make no attempt to explain the changes and advances in psychological theories, with the one exception of emphasizing the importance of instincts. The recognition of the nature, number, and power or influence of instincts has perhaps been the greatest change and advance; these instincts have been examined with the greatest care and exactitude, and have been defined with the utmost circumspection. Freud insists on the impulsive, demonic, illogical nature of much of human thought and the very partial and inadequate way in which consciousness reflects or represents the workings of these impulsive forces, which seem to be the driving power of life. Others have taken up the question, have enlarged the boundaries, and have built an edifice on a surer, steadier, and broader base.

Now let us consider for a moment the later cerebral physiology. Head showed that two forms of sensation—epicritic and protopathic—were present in sensory nerves; in the healing of a cut sensory nerve the protopathic sense returned long before the epicritic; the protopathic is concerned with somewhat painful or pleasurable sensations of heat or cold; it is vague and diffuse; it is conducted by the spinothalamic tract to the optic thalamus. The epicritic is much more discriminating; it is exact, differentiates, and the fibres travel by a separate tract to the cerebral cortex. The optic thalamus is the old brain. The neothalamus or cortex is later; it increases in size as we rise in the stages of evolution; it is with the cortex that the epicritic is connected. There are instincts of the protopathic type, and, as summed up by Rivers, they have the "all-or-none" principle in reaction:—

1. There is an absence of discrimination, of appreciation, or of gradation of response;
2. They have the character of reacting to conditions with all energy available;
3. And the character of the responses is immediate and uncontrolled.

These characters all hold good in large measure of the activity of the optic thalamus, the essential nucleus which Head and Gordon Holmes have shown to be the central representation of the protopathic aspect of peripheral sensibility and the essential basis of emotional reaction. The mad flight for safety of an animal is of this type; the instinct reaction for self-preservation is immediate, uncontrolled, with all energy available, and without discrimination; it is a panic. We need but to keep our eyes and ears open in everyday life to recognize examples; books of travel and the better class novel abound in them.

Or the opposite: The mad rush of aggression, bearing down all opposition, regardless of danger, is of the same type. The chance of success in both lies in thoroughness and completeness. In the better class of man we have an instinct reaction of self-preservation in what Rivers calls the "manipulative activity" reaction; the man at once instinctively becomes cool, quick-witted, without sense of fear or danger; he gets wounded and he feels no pain; each highly complex difficulty is met with dis-

criminating quickness of thought; this is a cortical or epicritic instinct reaction for self-preservation, and its success depends on the purity of its cortical nature. If a man "loses his head"—that is, if the epicritic nature of the instinct reaction wanes and the protopathic type interferes—his risks are quadrupled; he has the blind rage of the optic thalamus without its suddenness and full energy.

A good example of the contrast between the two is found in George Eliot's *Romola* (Chapter XXXIV) in the conflict between Tito, young, well nourished, selfish, and with a cool, scheming brain, and Baldassarre, old, exhausted by exposure, privations, disease, with fast failing mental powers; the sudden impetuous leap of the latter and his secondary collapse correspond very closely with Rivers's description. Romola's interview with Savonarola in Chapter LIX is a fine instance of a good, educated brain in a noble character acting under the strongest conflict and emotion, but always held in control; a weak cortex and weak nature would have gone into hysterics.

It is not difficult to see the resemblance between a protopathic reaction and a sudden outburst of an hysterical fit, or of mania, and a resemblance also to those cases where soldiers have suddenly taken to flight even into open danger.

Again we are not allowed by the public press just at present to forget that an animal may try to escape by sudden immobility or "shutting dead": it can be rolled over, touched, and yet not exhibit the faintest movement; it is apparently without feeling; the paralysis, anaesthesia, mutism of hysteria may have the same origin.

In this way Rivers endeavours to correlate the psychology, the latest cerebral physiology, and the psycho-neuroses; the instincts of the animal of the optic thalamic type become modified in those animals whose cortex has increased in size and complexity; in man, under the stress of war or civil danger, functional diseases in their manifestations hark back to his optic thalamic ancestor.

In passing, I may remark that the war has done two things. Freud made the sex instinct the central and most important factor; he enlarged the use of the word "sexual" to a perfectly absurd extent, and broke through the plain use of words and of facts. The older psychologists were jealous of his innovations and held up to scorn, contempt, and ridicule Freud and his sex theories. The first iconoclastic action of the war was to knock to pieces the supremacy of his sex instinct; the second was to confirm the truth of his mechanism of the unconscious, suppression, psycho-analysis, sublimation, projection, etc. Comparatively few of the neurasthenic soldiers showed any predominant sex instinct; they led the ordinary sex life and never worried about it, except when they got some venereal disease, but the vast majority showed "danger"—that is, "self-preservation and herd instincts," "suppression," "conflicts"; they were treated on these lines and cured; so that Freud's mechanism was established, but his "sex instinct" theory, which might be more in accordance with fact in the highly artificial and effete civil life of Vienna, had to come down from its pinnacle and take its place with the two other main classes of instincts—namely, that of "self-preservation" and that of the "herd."

Again, there has been an enormous increase of public interest in psychology; lay practitioners in psycho-analysis are already beginning to swarm in London; the inclinations of many, I am afraid, make for evil, and pander to the erotic vacuity of fashionable life. These charlatans will spread to provincial towns, and will soon be with us, and be adopted by the neurotic cranks of the district. Books are published as scientific treatises, whose illustrations and stories would delight the heart of the prurient pervert; but the higher class papers and reviews have also taken it up in a more legitimate manner.

A book on the psychology of employment, published recently in America, shows how the Americans are open to receive new ideas and improve their methods, and are not above taking lessons from any form of study; it deals with intellectual capacity generally, and emphasizes the two varieties: (1) General intelligence—capacity to benefit by experience and error; (2) specific ability.

A third reason why the profession should not be ignorant of the subject is the immediate need for the treatment of the large number of war "neurasthenics," and the still larger number—proportionately increasing as the true

"shell shock" gets well—of the degenerate, work-sly, malingering borderline case, who did no work before the war, as little as possible during the war, and do not intend to work after the war. The Ministry of Pensions has taken the responsibility of these men, and it is our duty to educate ourselves and the public as to how to deal with them; they do much harm to our wounded and war invalids. The war found us well prepared as regards the prevention of infection, moderately prepared as regards the treatment of wounds, but in hopeless ignorance as regards the prevention and treatment of psycho-neuroses. We tolerated before the war in a supercilious manner some practitioners who specialized in this class of patient: a few—but still too many—of these were cranks themselves or quacks who battered on credulity and gave the bad name; but we ourselves were ignorant; we were guided by no scientific principles. The elder surgeon looked with contempt on the bonesetter; he has now systematized the knowledge and experience of the bonesetter, and benefited the patient; the analogy is not too strained.

My object is to advocate the introduction of a simple elementary study of psychology, normal and pathological, into the wards of a general hospital, in order to formulate and systematize the instruction that is already given in a somewhat spasmodic and irregular manner; to train students and prepare them so that they will be able to benefit more fully by their attendance in the asylum, and be ready to take up this aspect of their professional life—the examination of a patient for responsibility of his actions, for testamentary capacity, and for the hundred small incidents that occur in our daily professional life, and the treatment of the minor mental ailments that form such a large part of general practice.

OBSTRUCTION BY A BAND IN A LARGE SCROTAL HERNIA.

BY
PHILIP TURNER, M.S., F.R.C.S.,
ASSISTANT SURGEON, GUY'S HOSPITAL.

INTESTINAL obstruction in a hernia, from causes other than constriction of the contents at the neck of the sac, is not of great rarity—I have heard of two such instances in the past year—but the following case presents features of unusual interest:

In September, 1919, I was asked by Dr. J. Thorpe Reckitt to see a case, apparently of strangulated inguinal hernia. The patient was a man, aged 69 years, who had a left inguinal hernia of remarkable size; its maximum length was about twelve inches and its circumference about eighteen inches while the patient was lying down in bed. The hernia had been present for forty years, and for many years—for how many the patient was unable to say—it had been irreducible and of its present size. No truss had ever been worn, but, in spite of its magnitude the hernia seemed to have caused him singularly little inconvenience. He was able to lead an active life and attend to his business right up to the present illness. Some few years ago the swelling had been tapped by a medical man, presumably under the impression that the scrotal swelling was a hydrocele. No fluid was drawn off, but the patient was unable to say whether anything was injected into the sac.

His illness, which may be said to have started three days before I saw him, commenced with pain and tenderness in the hernia, followed by absolute constipation, neither faeces or flatus being passed. The symptoms at first were apparently not severe, so that he did not send for Dr. Reckitt until the third day, when the pain had extended to the lower part of the abdomen and he had commenced to vomit. When seen during the evening of that day his condition was very grave; the vomiting had persisted and he was then bringing up small quantities of foul brown fluid at frequent intervals. The pulse was not very rapid, being 100 per minute, but was of small volume; the tongue was furred but moist and the eyes were decidedly sunken. The lower part of the abdomen was tender and rigid, but, owing to the presence of much fatty tissue it was not possible to say if there was any distension. It was considered that the hernia was strangulated, with probably gangrene of some of the

contents. As it was thought that the patient's life might possibly be saved by relieving the obstruction and tying in a Paul's tube it was decided to operate.

Operation.

An anaesthetic was given and the sac exposed and opened in the usual way. The contents were chiefly small intestine, with a portion of the omentum and a small amount of foul blood-stained fluid. The neck of the sac was very large, and there was no difficulty in passing two fingers through it into the peritoneal cavity; the intestine showed no evidence of constriction, and it became certain that we were not dealing with an ordinary case of strangulated hernia. The omentum was ligatured and excised to allow of investigation of the bowel. It was estimated that about half the total length of small intestine was present in the sac; it was but slightly distended and the serous surface was hyperaemic. At the lower part of the sac a coil about 12 in. in length was found to be black and gangrenous. This was caused by a well-defined, rounded, fibrous band attached at each end to the mesentery, crossing and constricting both the proximal and distal ends of the coil, but having no attachment to the intestine. The gangrenous portion of the gut was sharply defined by the line of constriction, which was very tight, and, in addition, the whole of the affected coil was twisted through an angle of about 180 degrees. The band was situated at least 6 in. below the level of the external abdominal ring, and there was certainly no obstruction at the latter situation. The patient's condition was too bad to allow of a resection, so that, after the band had been divided, the gangrenous coil was drawn into the wound, incised, and Paul's tubes were tied in. The upper three-fourths of the wound were then closed and the patient returned to bed. However, he did not rally, and died in about three hours.

The nature of the band which caused the obstruction is doubtful. It was a definite, rounded, cord-like structure, attached at each end to the mesentery, but as it had no attachment to the intestine it can scarcely have been derived from a Meckel's diverticulum, though the gangrenous portion of intestine was probably ileum. It certainly had no connexion with the inguinal canal or the external abdominal ring, and there was nothing to suggest that it was derived from the omentum, which was not adherent to either the gut or the sac wall. No other bands or adhesions were noticed, and, indeed, I think that the reason that the hernia was irreducible was on account of its size and long duration, so that the capacity of the abdominal cavity was insufficient to accommodate its contents; at any rate there was hindrance to reduction at the neck of the sac, and no adhesion between the sac wall and contents.

One cannot help thinking that the band may have been inflammatory in origin, and that it may have followed upon the tapping which had been performed some years before. When I saw the patient there was no suspicion of a hydrocele, and at the operation there was only a small amount of fluid in the sac. Under these circumstances it is quite possible that the trocar and cannula may have inflicted some injury upon the mesentery, and that, as the result of the inflammation thus set up, the band was formed. In support of this view it may be pointed out that the situation of the band was about the level which would be selected for the introduction of the trocar and cannula in tapping a hydrocele. Whatever the cause of the band may have been, it is certainly a very unusual occurrence for a portion of the contents of a hernia to be obstructed in this way.

THE RADICAL CURE OF VARICOCELE.

BY
SIR JOHN O'CONNOR, K.B.E., M.A., M.D.,
SENIOR MEDICAL OFFICER, BRITISH HOSPITAL, BUENOS AIRES.

SOME six years ago¹ I called attention to a simple and exact method of excising the eight or ten varicose spermatic veins (the pampiniform plexus) which are suspended, in loose areolar tissue, mostly in front of the vas deferens. It is essential to punctuate the fact that surgical intervention must be exclusively confined to removal of this bundle of veins, otherwise disastrous consequences are certain to ensue—for example, gangrene or atrophy of testis. I have seen many examples of the latter, and recently a very painful instance of the former—a gentleman who, just before embarking for Buenos Aires, was operated on by a well known English surgeon; on his arrival here he was suffering from marked toxæmia and a foul septic scrotum. I had to remove a gangrenous

testicle and found the cord itself tightly constricted in the ligature.

I cannot help thinking that operative textbooks are largely responsible for these mishaps by recommending procedures possessing needless magnification of perspective which often results in anatomical obfuscation—too much exposure and too much dissection frequently produce too much surgery. The essence of the thing is first to realize that the pampiniform plexus is situated anteriorly to the other structures of the cord, and then, before making the incision, to take care to secure it in that position—always remembering that the object is to remove a superficial bunch of varicose veins endowed with a definite topographical site, which may be easily confused by over-dissection and unnecessary manipulation of the part.

The operation which I have employed for some years past is as follows:

1. This clump of varicose veins is seized horizontally between the left thumb and left index finger. A pause is made, to be certain that the cord lies free and well posterior to the gripping fingers. This is verified by palpation with the right thumb and right index finger, and I generally demonstrate the position of the cord to some onlooker by rolling it close under the skin for inspection.

2. A two-inch incision is then made over the gripped projection; with a few horizontal strokes of the knife the infundibuliform fascia is divided, the offending plexus pops into the wound, and with a few more touches it is completely exposed through the whole length of incision.

3. These veins are then caught in mass by an artery forceps, which is handed to an assistant, who pulls it vertically upwards so as to bring the underlying connective tissue into view.

4. A stab of the scalpel makes an opening through this tissue sufficient for the introduction of the right index finger; this done, the left-hand grip is released, and the left index finger is instantly inserted alongside of the right one beneath the bundle of veins.

5. The pampiniform plexus is now freely separated from its bed by the two fingers (one working up and the other down) and as many inches as may be considered necessary are easily and rapidly isolated.

6. A catgut ligature is applied above and below, the intervening segment (usually 2 to 4 in.) of plexus is excised; the ends of ligatures are then tied so as to approximate stumps and to elevate scrotum, and the skin wound is united by a few catgut stitches, leaving room at the upper and lower angles for the passage of a slender wisp of silkworm gut—a precautionary hæmorrhagic drain which I employ in all scrotal wounds.

The facility with which this little operation may be done can be estimated by the time occupied in its performance²—one to three minutes. The results warrant its commendation to others.

REFERENCES.

¹ *Lancet*, October 24th, 1914. ² "Operating to the Clock," *BRITISH MEDICAL JOURNAL*, December 21st, 1918.

Memoranda:

MEDICAL, SURGICAL, OBSTETRICAL.

LIGATIONS OF THE LEFT SUBCLAVIAN ARTERY.

IN the *JOURNAL* of April 16th, under the above heading, the possibility is suggested that some surgeons may have performed this operation without having recorded the fact in print. That this supposition is correct in at least one instance is borne out by the following case on which I operated during the summer of 1918 in France. No doubt other surgeons during the great war had somewhat similar cases.

A soldier was received at a base hospital with the diagnosis of gunshot wound of the shoulder. He complained of pain in the neck. The wound was discovered only after careful search, and consisted of a tiny seab in the neck, above the inner end of the left clavicle, about an eighth of an inch in diameter. There was no other physical sign except some tenderness on deep pressure. Had he not consistently complained of pain, and at times given the impression of undoubted suffering, he would have been sent to rejoin his unit almost immediately. However, a few days after admission there appeared gradually a small red swelling, hard and tender to the touch, in the neck just behind the inner end of the left clavicle. There was no pulsation. The classical error

was committed, and "abscess" diagnosed. An x-ray plate revealed a tiny fragment of shell about the same size as the wound, deeply situated in the region of the swelling.

A small superficial incision was made over the red area, and a pair of artery forceps pushed deeply into the supposed abscess. No pus appeared. The finger was then introduced, and, the deep parts of a small cavity being disturbed, there followed an alarming gush of blood, easily controlled, however, by pressure of the tip of the finger on the pulsating artery, in the anterior wall of which there apparently was a tiny wound.

The remaining part of the operation was performed with the tip of the left index finger on the artery at the bottom of the wound, an assistant retracting and ligating, an orderly pulling the left arm downwards and the anaesthetist forcing the head firmly towards the right shoulder. A long incision was made transversely across the neck, just above the clavicle and including the original opening. The dissection which followed was naturally long and tedious, punctuated by various "alarms and excursions." The clavicular head of the sterno-mastoid was cut across. The supra-clavicular artery and various veins were ligatured and divided. The inner margin of the scalenus anticus and the thyroid axis artery were recognized. The latter was followed to its origin from the subclavian, and the finger-tip on the puncture was just internal to the point of origin. With as little disturbance of the subclavian as possible, and after a little blunt dissection, two pairs of artery forceps were applied to the artery close together, and these occluded the puncture and controlled the hæmorrhage. An aneurysm needle was passed round the artery, first immediately internal to and then immediately external to the forceps, and the vessel was ligated in two places with thick catgut.

The wound was stitched and a small drainage tube was left in position for twenty-four hours. The arm was wrapped in cotton-wool and placed in a modified Thomas's arm splint in the horizontal position. No complications arose, the wound healed by first intention, and the patient was evacuated to England within three weeks.

Birmingham.

W. GERRILL, F.R.C.S.

DERMATITIS CAUSED BY BITTER ORANGE.

OCCUPATIONAL dermatitis due to the handling of certain flowers and plants is well known, but cases are not very common, so that they may be rather difficult to recognize. In *Sequeira's Diseases of the Skin* is given a list of over forty plants which are known to have caused dermatitis. Among them is the bitter orange, and several cases of this form of dermatitis recently came under my notice among girls engaged in peeling bitter oranges in a jam factory.

The most marked case was that of a girl, aged 25, who suffered from a very acute dermatitis of the fingers, hands, and forearms, and also of the face. There was intense erythema and much swelling, especially of the hands and forearms, the parts most exposed to the juice. There were numerous small vesicles, a little larger than the size of a pin-head, all over the affected areas. I put the patient to bed for one week and applied a lotion of zinc carbonate, pulv. calaminæ and aq. calcis, which proved very effective, the inflammation entirely disappearing after ten days. Idiosyncrasy evidently plays a considerable part in the condition, as in spite of all precautions the girl in question had ultimately to give up the work.

Glasgow.

F. ANDERSON MURRAY, M.D.

A STELE in memory of the internes of the Paris hospitals who died on active service during the war has been erected at the Hôtel-Dieu. On it are inscribed 72 names; it is ornamented by a bas-relief showing a first-aid post.

AT the meeting of the Congrès de Chirurgie at Strasbourg on October 3rd, the President, Professor E. Bocockel, will be presented with a medal in recognition of his patriotism during the German occupation.

THE tuberculosis mortality at Rio de Janeiro, which in 1903 was 4.43 per 1,000, rose to 5.53 in 1918, and is now 10 per 1,000. Amaury de Medeiros, general secretary of the Association for Combating Tuberculosis in Brazil, estimates the annual number of deaths from tuberculosis in Brazil at 60,000, and the number of cases at 600,000.

Rebielus.

AN ATLAS OF OBSTETRICS.

IN his *Atlas of Normal Labour*¹ Dr. DRUMMOND ROBINSON has reproduced a large number (405 to be exact) of the diagrams and photographs which went towards the constitution of the "animated diagrams" and motion photographs introduced by him to the profession a year or more ago. It will be recollected that he demonstrated these before a meeting of the Obstetrical and Gynaecological Section of the Royal Society of Medicine in November, 1919, and since then they have been shown in other centres. At that time (November 15th, 1919) we referred to the exhibition of the films, and generally to the use of the cinematograph in medical teaching. Now it remains only to say that the publication of the atlas will help to convey to many who have not had the opportunity of seeing the pictures in motion some idea of the nature of the teaching which can thus be given. Present prices make the purchase or even the hire of the films possible only for large classes, but the salient features may be picked out in the atlas in the tutorial class and made the pegs upon which to hang much practical teaching.

The *Atlas* affords an interesting opportunity of studying at leisure the individual pictures, and so minute are the differences between the consecutive diagrams of a series (and probably they are far from being consecutive in the film) that one is lost in admiration of the care and patience on the part of the author and artist which must have gone to make them so successful and (in the case of the diagrams) so lifelike. The photographs, like all surgical photographs, suffer from the obscuration of the field by blood, which appears a dense black in colour. Apart from this unavoidable drawback they are excellent.

This is a book to be welcomed—perhaps not so much for what it contains as for what it is. For it is a pioneer book, and years hence will be looked back upon with interest by those who regard the cinematograph as a regular part of the stock-in-trade of the teacher of the practical branches of medicine and surgery.

INJURIES OF PERIPHERAL NERVES.

AN able exposition of what is to be regarded as representative of the work of the German school of surgeons on injuries of peripheral nerves has been issued from the surgical clinic of the university of Göttingen. The author, Dr. WALTHER LEHMANN, has dealt with the subject from its civilian and military aspects, but as in all countries, the experiences of war surgery are rightly allowed to dominate the whole essay.² It is interesting to note the complete absence of any reference to the work done in countries other than the Central Powers, although a very extensive bibliography is included. This omission is probably an advantage, as it allows the reader to formulate a sure opinion as to the attitude of the German school towards this important section of reconstructive surgery, and to make comparison between it and that of the French and British surgeons and neurologists. We arrive at the general conclusion that, allowing for minor differences, this surgical field has developed along parallel lines in all countries.

A short but clear account is given of the main principles involved in the healing of nerves, and of the pathogenesis and the symptomatology of nerve injuries. It is stated quite simply, but without undue dogmatizing, that recent work has strengthened the peripheral theory of regeneration, and that the constant topographical anatomy of peripheral nerves established by Stoffel has not been confirmed by the work of Borchardt and others.

In discussing the operative repair of injured nerves the author emphasizes the reasonableness of a conservative attitude, and in lesions of the complete anatomical type, where nerve suture is indicated, he is insistent on the necessity of obtaining end-to-end apposition at all costs,

even if the line of section of the nerve stumps passes through tissue which is far from ideal. The operations of nerve grafting, tubularization, repair by flaps, and anastomosis are dealt with fairly in view of the isolated reported successes, but one is left in no doubt as to the general consensus of opinion in Germany on their inapplicability in practical nerve surgery. In discussing the prognosis of nerve repair emphasis is laid on the superiority of the regenerative process in young people, and this is assumed, although without any statistical support, to be one of the determining factors. Stress is laid also on the importance of early suture, and this view is supported by conclusive statistics from the civilian and war literature.

The available statistics of recovery after suture in warfare injuries are comparatively few in Germany, and the author adopts a pessimistic tone as to the general chances of adequate recovery, except in the case of the musculospiral nerve. Secondary re-exploration for failures is not considered worth while, except where the previous operation was a neurolysis, and resection and suture is indicated as a primary measure. The value of alternative operations in irreparable injuries is discussed lucidly, and considerable space is allotted to a technical description of the tendon transplantation operation for irreparable musculospiral injuries as introduced by Perthes. In this, tenodesis of the wrist is an essential step, and the operation differs considerably from the classical British operation, which has never been improved upon in any country.

This work is well illustrated, and British readers will be grateful for a simplicity of style long considered to be an unusual feature of Teutonic surgical literature. In some ways it is probably the best balanced essay on this subject which has yet been produced, and it can be recommended to the serious attention of all surgeons who are interested in this particular field.

PARTIAL OPERATIONS ON THE PROSTATE.

DR. LIONEL ESCAUDE is a disciple of Luys and an enthusiastic advocate of the latter's treatment of hypertrophy of the prostate by "forage." His publication *Le Forage de la Prostate*³ begins with a historical summary of our knowledge on the subject of prostatic hypertrophy. In it special stress is laid on the frequency with which a prostatic bar constitutes the only obstacle to micturition. By the destruction of this bar a free outlet is provided for the passage of the urine. After passing in review the various partial operations, such as those of Bottini and Goldschmidt, which have been advocated for enlargement of the prostate, the author describes in detail the technique of Luys. The work of destruction is carried out through a Luys's direct cystoscope by means of a special electrode connected with a diathermy apparatus. The precise form of apparatus recommended by the author is that of D'Arsonval, which is simple and makes it possible to regulate accurately the intensity of the current. The technique of Luys's operation is well described, the text being reinforced by the addition of excellent illustrations. The author regards as contra-indications to the method the presence of sepsis or the existence of a great enlargement of the entire prostate. He states that the method is specially applicable to younger men showing very little change except the existence of a prostatic bar, and also to old cases with dangerous involvement of the kidneys. In only three cases out of a very large series did difficulties of micturition recur, and in these further treatment by means of "forage" sufficed to remove their troubles. The book concludes with details of 63 cases treated by these means. An analysis of the first 49 showed that the following types of operation were required: In 20 cases the removal of the prostatic bar, in 2 cases the treatment of the lateral lobes only, in 27 cases the removal of the bar associated with treatment of the lateral lobes. In 90 per cent. of the cases excellent results were obtained, frequency, pain and difficulty entirely disappearing. In 6 of the cases treatment had to be given up on account of the greatness of the enlargement. Altogether the book furnishes an excellent monograph on the subject of partial operations on the prostate. Although the author is an enthusiast, he nevertheless treats the subject in a fair spirit.

¹ *An Atlas of Normal Labour*. By G. Drummond Robinson, M.D. London: Wm. Heinemann (Medical Books), Ltd. 1920. (Double crown, 8vo., pp. 104; 405 figures, 25s. net.)

² *Die Chirurgie der peripheren Nervenverletzungen, mit besonderer Berücksichtigung der Kriegs-Nervenverletzungen*. By Privat-docent Dr. Walter Lehmann. Berlin and Vienna: Urban and Schwarzenberg, 1921. (Sup. roy. 8vo., pp. 283; 66 figures, 3 plates. M. 104.)

³ *Le Forage de la Prostate, méthode de Luys*. By Dr. L. Escande. Mulhouse: S.A. des Établissements d'Imprimerie A. Herbellin. 1921. (Roy. 8vo., pp. 102; 26 figures.)

ANAESTHETICS.

*The American Year Book of Anesthesia and Analgesia*⁴ contains some valuable papers on physiological questions besides a number of contributions dealing with purely clinical matters. The latter are very largely concerned with anaesthetics in military surgery and have been put before us comparatively recently by many writers, including the authors represented in the *Year Book*. Among the other clinical contributions is a valuable paper from the Mayo Clinic by F. A. Willus. Although the number of cases dealt with is not very great, the accurate and detailed observations give weight to the definite opinions expressed. Willus deals with the operative risk in heart lesions under anaesthesia. His cases are classified in six groups—auricular fibrillation, auricular flutter, impaired auriculo-ventricular conduction, impaired intraventricular conduction, mitral stenosis, and aortic lesions. They include "the first proved case of flutter coming to operation." In his summary the author states that "the general tendency is to require too great a margin of cardiac safety in surgical work." F. C. Richardson also writes on heart lesions in relation to anaesthesia. He deprecates the use of scopolamine and thinks that spinal analgesia should not be used in any patient who cannot stand a temporary fall in blood pressure of 50 per cent. "More heart cases require rest after the operation than require stimulatives" is one of his conclusions. Embley contributes a paper on the pharmacology of ethyl chloride, proving experimentally the lowering of blood pressure by this drug and its effect on circulation through the vagus and peripheral dilatation. The importance of temperature in relation to anaesthesia is treated by Shipway and Pembrey, whose work has already been fully recorded in this country. Davis and McCarty, discussing the relative value of so-called warmed and unwarmed ether vapour, are diametrically opposed in some of their conclusions to the opinions of the above-mentioned observers. Crile's paper on an experimental research into the nature of nitrous oxide and ether anaesthesia contains his views on acidosis and anaesthesia, which are well known. The sitting position in nose and throat surgery, always a favourite with some operators in Great Britain, receives reasoned support from Deuman and McKesson and W. H. Roberts. These articles are elaborately illustrated. Blood changes under anaesthesia and circulatory disturbances under anaesthesia are the subject of a number of good papers from Mann, Casto, Polak, and others, and low levels of carbon dioxide and alkali during ether anaesthesia are discussed by Yandell Henderson. The volume covers a wide field of work, and contains much of interest both to the practical anaesthetist and to the laboratory worker.

In his *Précis de Rachianesthésie générale*,⁵ G. LE FILLIATRE gives an admirably clear account of his method of spinal anaesthesia, and of the anatomical and physiological grounds on which he has based the procedure. His plan is fundamentally different from the usual spinal analgesia. He does not aim at a local influence but at a general paralysis of all the posterior roots. This he achieves by the use of a dilute solution of cocaine (1 in 50) which he employs in a manner that is, according to his account and experience, free from risk. Cocaine, of course, in ordinary spinal work has long been given up as too dangerous. Le Filliatre maintains that all risk in spinal injection and all serious conditions following an injection are due to hypertension of the cerebro-spinal fluid. This is caused by excessive secretion due to the introduction of a liquid which irritates the arachnoid membrane. He avoids this hypertension by first of all allowing 25 to 30 c.c. of the cerebro-spinal fluid to escape before he makes his injection, and secondly, by using an injection of dilute cocaine solution in a particular manner. This manner is described under the term *barbotage* (*barboter*—to dabble or paddle). It consists in allowing the syringe to fill again after the injection has been made, then reinjecting this amount of cerebro-spinal fluid, then allowing it to fill the syringe again, and then reinjecting once more. In this

way his original dose of dilute cocaine (3 to 6 cg. of cocaine in a 1 in 50 solution) is still further diluted with cerebro-spinal fluid before it is diffused. The spot chosen for the puncture is the lumbo-sacral space, the interval between the fifth lumbar and first sacral spinous processes. Here he finds the greatest diameter antero-posteriorly of the subarachnoid space, and the least chance of damaging nerves which are here closely related to the walls of the space, not freely passing through it. A preliminary injection of "hypospethesine," which contains scopolamine, morphine, strychnine, and sparteine, is an essential part of the method. Chemically pure cocaine hydrochloride is used, and the solution is either made at the time with sterilized distilled water or obtained from ampoules containing 6 cg. of cocaine. This dose gives an anaesthesia of the upper regions of the body, including the head, lasting three-quarters of an hour to one hour. The *Précis* is very clearly printed and the illustrations are both artistic and helpful.

LUCIANI'S "HUMAN PHYSIOLOGY."

THE fifth and final instalment of the English translation of the late Professor LUIGI LUCIANI'S standard work on *Human Physiology*⁶ has been edited by Professor M. S. Pembrey, and appropriately so, for it deals with metabolism, temperature, reproduction, the stages of life and death, and the races of mankind. The first volume of this translation appeared ten years ago, the second in 1913, the third in 1915, the fourth in 1917, and the final one now sees the light nearly two years after the distinguished author's death in his eightieth year on June 23rd, 1919. The disadvantages of this delayed publication are obvious, and no doubt are in part contingent on the great war, but the translation has been fortunate in its editors—Dr. M. Camis, of Pisa, responsible for the first and second volumes, and Dr. Gordon Holmes for the instalments on the muscular and nervous systems and the sense organs. In our previous reviews the excellence of Miss Frances Welby's translation, which recalls the charming style of the late Sir Michael Foster's textbook, has been emphasized, and, although the name of the translator of the final volume is not revealed, the high standard thus set up has been well maintained.

The history of experimental metabolism is sketched from 1614, when Sanctorius's book, *De Medicina Statica Aphorismi*, appeared at Padua. As they are not described elsewhere the editor has added a brief note on vitamins, but has referred the reader to Professor Hopkins's papers and the Medical Research Council's special report series for further information. The chapter on the theory of human nutrition contains a full description of Chittenden's observations, including those on the late Horace Fletcher, who maintained his health and weight on less than half the daily protein intake as estimated by Voit, and their importance as an argument for economy in nutrition is emphasized. The view put forward long ago by the late Sir Henry Haldord in his essay on "The Climacteric Disease," that in males there is a critical period of from one to four years corresponding to the menopause in women, and in 1910 attributed by Mendel to diminished secretion (internal or external) of the generative glands, is dismissed, on the ground that of the observations upon which it rests a large proportion can be explained as casual morbid symptoms arising from causes quite distinct from those suggested by Mendel. After a full and fair presentation of Metchnikoff's well known conception of the harmful effects of enterogenous bacterial toxins and macrophages, it is shown that old age is not a morbid process due to auto-intoxication, and that it is, therefore, useless and erroneous to expect that fermented milk and hygienic precepts, excellent as they may be in themselves, will prevent the inevitable process of physiological involution.

There is an interesting historical summary of the problem of death; life and death are not separated from each other by any exact boundary, and, in spite of much research, the precise moment of death cannot be fixed in single tissues except by rigor mortis in the muscles. The immediate cause of death is always intrinsic to the

⁴ *The American Year Book of Anesthesia and Analgesia, 1917-1918*. Edited by F. H. McMeelan, A.M., M.D. New York City: Surgery Publishing Co., 1921. (Demy 4to, pp. 483; 175 figures, 10 dols.)

⁵ *Précis de Rachianesthésie*. By G. Le Filliatre. Paris: Librairie E. Le François, 1921. (Imp. 16mo, pp. 125; 29 figures. Fr. 8; post free, Fr. 8.80.)

⁶ *Human Physiology*. By Professor Luigi Luciani, Director of the Physiological Institute of the Royal University of Rome, with a Preface by Professor J. N. Langley, F.R.S. Vol. V: Metabolism, Temperature, Reproduction, etc. Edited by Professor M. S. Pembrey. London: Macmillan and Co. (Med. 8vo, pp. 422; 158 figures, 30s.)

organism as a whole, even when brought about by some external agency, but is extrinsic to the elements of a large number of the tissues, being due to functional failure of the organs and tissues essential to life, and spreading from them, so that all the parts of the body do not die at the same time. The last chapter, dealing with ethnology and anthropology, has been contributed by Professor S. Baglioni, and contains some excellent photographs of the different human races. The illustrations, a number of them coloured, and the general get-up of the work, are alike admirable.

LUNACY IN INDIA.

DR. A. W. OVERBECK-WRIGHT, the author of *Lunacy in India*,⁷ is the Medical Superintendent of the Agra Asylum, and Lecturer on Mental Diseases to King George's Medical College, Lucknow. He has had a wide and varied knowledge of the East during a period of nineteen years, and thus writes on a subject in respect to which he has had a vast experience. While his book contains some details of general psychiatric interest its title is perhaps not quite expressive of its aims, as it is primarily a textbook designed for the use of the practitioner in India. It contains the usual subject-matter of the conventional textbook, together with an account of special legal points and methods of certification peculiar to the country to which it refers.

The provision for the suitable treatment of the insane in India is evidently far from adequate, since the author states that in an area with 67,836 insane there is only asylum accommodation for 7,234 patients. After naming the reasons for this deficiency, he expresses the hope that local sects and bodies will form institutions of their own as they become more enlightened as to the nature and causation of insanity. In the Census Report for 1911 the proportion of insane to general population is noted as 26 to 27 per 100,000, a figure which compares well with that of 364 per 100,000 for England and Wales. The difference is, however, more apparent than real, as the Indian statistics do not include the weak-minded, and for this and other reasons an accurate survey would probably approximate much more closely to the English percentage. The author raises many points of interest, and amongst them he notes that in India the use of opium, a drug which is there usually taken in pitular form, does not produce any conspicuously evil effects. There is no tendency to the marked mental and physical decay which is observed so commonly amongst those who smoke it, or who take it by injection in the form of morphine. Cases of insanity due to its consumption are practically unknown.

The section devoted to clinical psychiatry is well written, and the author lays stress on the physical aspects of mental disorder. He follows the classification of Dr. Lewis C. Bruce, with whose views he is in accord as to the importance of toxic factors in the production of many forms of insanity. The various clinical groups are described in detail and illustrated throughout by reference to actual cases. We can thoroughly recommend this book, which would seem to meet a definite need. The practitioner in India will find in it a reliable guide in dealing with cases of mental disorder in both their legal and medical aspects.

"THE MEDICAL ANNUAL."

The Medical Annual,⁸ now in its thirty-ninth year, fills a niche of its own in the medical library. It is the sort of book that one likes to have at hand and into which one can dip at any time—for a few minutes or for an evening—with pleasure and with profit. The first part contains a dictionary of materia medica and therapeutics by Dr. Frank J. Charteris, and although he finds that "the year under review has not been fruitful in important work" in therapeutics, there are useful notes on protein therapy and other subjects. Included also in this part is a concise review by Dr. Thurstan Holland of developments in radiography and electro-therapeutics. The second part of the *Annual* is a dictionary of treatment, composed of numerous notes and articles summarizing medical and surgical progress in 1920 by some thirty contributors. Among the most interesting are those on deficiency diseases by Dr. J. A. Nixon;

⁷ *Lunacy in India*. By A. W. Overbeck-Wright, M.D. (Psych. Med.), B.Ch., D.P.H., Major I.M.S. London: Baillière, Tindall, and Cox. 1921. (Demy 8vo, pp. x + 465. 21s. net.)

⁸ *The Medical Annual*. Thirty-ninth year. Bristol: J. Wright and Sons, Ltd. London: Simpkin, Marshall, Hamilton, Kent and Co., Ltd. 1921. (Demy 8vo, pp. 724; 40 plates, 134 figures. 20s. net.)

on the blood by Dr. O. C. Gruner, which is illustrated by some remarkable coloured diagrams; on psychological medicine by Dr. J. A. Hadfield, which gives a sane and readable account of psychotherapy; and on encephalitis lethargica by Dr. Ramsay Hunt, which covers the most recent researches on this disease. The article on orthopaedic surgery by Dr. Fred. H. Albee and Dr. R. F. Carter of New York is an admirable and well illustrated review, which does not over-emphasize, but does not suppress, the personal opinions of the authors. A useful survey of recent work on the surgery of the stomach is contributed by Mr. James Sherren. To simplify reference for readers all advertising matter has this year been removed from between the title-page and the body of the work. At the end of the volume are useful lists of new medical preparations and appliances, the principal medical works published during the year, medical institutions, sanatoriums, and nursing homes, and the principal British spas. There is also an official and trade directory, which includes lists of the medical and scientific societies and periodicals. The volume is well illustrated, in black and white and colour, and admirably indexed.

THE ANNALS OF MEDICAL HISTORY.

THE first part of Volume III of *The Annals of Medical History*,⁹ containing nine interesting articles, editorials, notes and book reviews, sets a standard of printing and reproduction of illustrations that must compel our admiration and envy. The opening article by Dr. J. Collins Warren on the collection of the Boston Phrenological Society, which flourished for ten years, being founded on the evening of the funeral of Spurzheim (1776-1832), who died in Boston from typhoid fever, endorses the growing modern opinion that, though much obscured by their advocacy of phrenology, Gall and Spurzheim's painstaking work really entitles them to a place among the pioneers of research leading up to the modern conception of cerebral function. Dr. L. M. Griffiths, of Bristol, writing on Shakespeare and the practice of medicine, shows that the extravagant claims for his insight into matters medical cannot be allowed, and that the statement that he always paid respect to the profession is not borne out by his references. An ancient Egyptian prescription for hysteria on an ostrakon in the Metropolitan Museum of Art, New York, dating from about 1500 B.C., is described by Dr. I. H. Coriat, and this article is followed by Dr. H. B. Jacobs's address to graduating nurses on Elizabeth Fry, Pastor Fliedner, and Florence Nightingale. Dr. J. C. Hemmeter gives an account of Leonardo da Vinci as a scientist, and Dr. J. H. Skavlem deals with the scientific life of Thomas Bartholin. Dr. D. A. Wells rightly says that Sir William Osler's life-story may well prove a benediction to those in the daily grind who seek equanimity of soul, and that, as a great man has been defined as several men in one, he finds in Osler three—the man of science, the man of literature, and the man of philosophy. Short articles on an Assyro-Babylonian treatise on diseases of the male genito-urinary organs and on the giving of medical degrees in the Middle Ages by other than academic authority are contributed by Dr. E. Podolsky and by Dr. H. Friedenwald. Among the book reviews there is a full and eulogistic notice of Dr. R. Hingston Fox's *Dr. John Fothergill and His Friends*, which was reviewed in our columns on June 14th, 1919, p. 739. The portrait on the cover of this number of the *Annals* is one of Raymond Viessens (1634-1713) from Montpellier, provided by Dr. C. Greene Cumston, who corrects the oft-repeated error that this famous anatomist was a professor of the subject.

NOTES ON BOOKS.

The New Pocket Medical Formulary,¹⁰ by Dr. W. E. FITCH, is a compendium of prescriptions, diet lists, tables of differential diagnoses, dose lists, and similar items, intended for the physician, student, and pharmacist. The little book is now in its third edition, so that it has evidently appealed successfully to the public for whom it is intended, and many of its formulæ are certainly valuable. But when, in a volume published in the year 1921, we read in

⁹ *Annals of Medical History*. Vol. III, No. 1, pages 1-95. Edited by Francis R. Packard, M.D. March, 1921. New York: Paul B. Hoeber. Subscription 8 dollars; single numbers 2.50 dollar.

¹⁰ *The New Pocket Medical Formulary*. By W. E. Fitch, M.D. Third edition, revised. Philadelphia: F. A. Davis Co. 1921. (Fcap. 8vo, pp. 480; one illustration. 2.50 dol. net.)

the paragraph devoted to the subject "Peritonitis" that "the patient must be kept under the influence of opiates for two days at least," we are a little apt to overlook many of the other merits of the volume.

A surprisingly large number of scientific workers are unable even to join a glass tube or make a T-piece that will not crack spontaneously, and it is to them that the *Handbook of Laboratory Glass-blowing*,¹¹ by Mr. BERNARD BOLAS, is addressed. A complete outline of the methods used in making commercial apparatus is not attempted, but by following its many valuable directions and hints the student should achieve increasing success in his efforts to manipulate glass in the laboratory.

¹¹ *A Handbook of Laboratory Glass-blowing*. By B. D. Bolas. With numerous diagrams in the text by N. Bolas. London: G. Routledge and Sons, Ltd. 1921. (Cr. 8vo. pp. 112; 17 figures. 3s. 6d. net.)

APPLIANCES AND PREPARATIONS.

An Anaesthetist's Screen.

DR. C. A. STIDSTON (Wolverhampton) writes: The following is the description of an anaesthetist's screen which I have recently devised. It consists of an upright tube 11 in. high, which can be screwed firmly on to any table: out of this telescopes a second tube 10 in. in length, on to which another tube 13 in. in length screws at right angles, and from the latter telescopes a fourth tube 21 in.

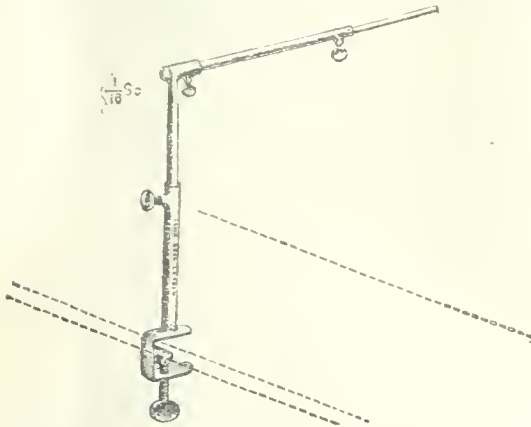

in length. By adjusting these tubes and their controlling screws in a vertical and horizontal direction a towel rail from 11 in. to 20 in. in height and 14 in. to 36 in. in length can be fixed at any angle across the patient's body.

While primarily intended for use in operations on the neck and chest under general anaesthesia, the screen can be used also for operations on all parts of the body below the head under local anaesthesia. The component parts are light in weight and pack easily into a small compass. The screen has been made by Messrs. Down Bros., St. Thomas's Street, Borough, S.E.

PHYSICAL SCIENCE AND THE LIVING ORGANISM.*

BY

A. V. HILL, Sc.D., F.R.S.,

PROFESSOR OF PHYSIOLOGY, UNIVERSITY OF MANCHESTER.

This lecture is meant to deal more with the general spirit than with the precise details of scientific methods applied to the problems of the living creature. Thirty or forty years ago a speaker on this subject might have tried to convince his audience of the advantages of a materialistic philosophy of life. If he had not done that, he would probably have "sided with the angels," and attempted to persuade them that the orthodox Christian faith was a sufficient account of the mysteries of life. It is only ten years ago that I attended a crowded lecture at Jena, in which William Ostwald the chemist, incited by Ernst Haeckel the biologist, reduced the whole world, conscious and unconscious, to manifestations and transformation of energy. Mine is a much humbler rôle. I shall not try to convince you that you and I are merely complicated systems of electrons, whirling away for a little while and in a moderately stable manner, on the road leading from the nothing whence we came to the nothing whither we go. I shall not attempt to mystify you, as Haeckel did our fathers, with the blessed

word "protoplasm." Neither shall I ask you to believe that the consciousness which we call *You* and *I* is merely an elaborate and convenient mechanism designed by natural selection to render our journey on that road a little longer and more comfortable, and our end less sudden. Nor shall I try to persuade you that intellect, goodness, beauty, and all the things that men strive after, are nothing but general relations of a physical universe, evolved somehow to secure the survival of the human species. Indeed, I want to persuade you of nothing more romantic than the advantages of exact scientific methods of studying the behaviour of the living creature.

The living creature is a very strange thing. Here it is in a physical, material, mechanical, chemical universe showing the most extreme dependence on physical conditions. It dies if it be frozen, or boiled, or deprived of food; it does not like strong acids, or ultra-violet light, or x rays, or trivalent positive ions; its properties depend to a most extraordinary degree on those of water; it conducts electricity; it obeys the laws of motion, of the conservation of energy, of the conservation of mass; and yet at the same time it shows, in its simplest forms, a complexity, an apparent purposefulness, an individuality, defying any physical hypothesis. One could treat a chemical theory of consciousness, or a physical theory of heredity, or a mechanical theory of intelligence, only one degree more seriously than the instruments recently designed by Mr. Edison for facilitating telephonic communication with the next world. And yet, deprive the brain of oxygen for a few seconds and consciousness is gone; remove the thyroid gland and a beautiful and intelligent child becomes a hideous imbecile; subject the egg-cell of some species to an appropriate salt solution and an individual will develop without a father. The absence of certain chemical bodies prepared inside the body by the thyroid gland, the lack of oxygen to carry on certain necessary combustions in the brain cells—both simple chemical changes—have obliterated the essential characters of the highest form of life. Wherever we look we find life in only one form, composed of compounds of hydrogen, oxygen, nitrogen, and carbon, living between certain narrow limits of temperature, giving out exactly as much energy as it takes in, dependent on the supply of foodstuffs from outside, exhibiting certain electrical properties, poisoned and destroyed by the most absurdly small doses of certain chemical substances. It is clear that the living creature does depend largely on purely physical factors. Largely, but how far?

Consider the case of heredity. The union of two cells starts off a developing organism, as small as a flea, or as large as a whale, in most respects very like its parents, but in some very unlike—a separate individual. We are so used to this recurrent miracle that most of us regard it as a commonplace: you would not regard me as speaking seriously if I said that I am daily amazed by the fact that the offspring of man is man, when it might have been an ox, an onion, or a tree. Consider all the complexity of a man—his elaborate physical body; his intricate, sentimental, adventurous mind; his extreme stupidity in examinations; the subtle inheritance of voice and manner, of colouring and movement, of aptitude of body and mind; all alike from one generation to another, yet with ever-varying individuality; all inherited through a little cell which bears to a tadpole the same relation as a second to a lifetime. Add to this the faculty of handing on the same characters to countless successive generations. Adopt the purely physical theory of life, and all future history is wrapped up in a little cell so small that you cannot see it at all without a microscope. It would seem inconceivable that any man should attempt to build a physical or chemical theory of inheritance.

Or, again, take the case of consciousness, our awareness of things, our conviction of free-will and self-determination, despite all the arguments of philosophers. Is it conceivable that the most ingenious designer of instruments could make a penny-in-the-slot machine possessing, even for a moment, this type of consciousness? And yet, apply a simple physical change—turn on the gas in his bedroom, give him a few milligrams of a salt with a positive trivalent ion, deprive him of oxygen, raise his temperature a few degrees, and all the elaboration, all the sentiment, all the stupidity in examinations, all the power of carrying on the inheritance, are gone. Where—if anywhere—does physics end, and where—if anywhere—do we come up

* A public lecture delivered at the University of Manchester.

against the fundamental biological and spiritual realities of life? I cannot answer that question, and all I shall try to do is to show that attempts to answer it are not profitless; indeed, that progress in the knowledge of the living creature comes largely, and will come mainly, from attempts to solve it by the methods and tools, mental and material, of the exact sciences. And remember that progress in our knowledge of the living creature means progress in medicine, in industry, in agriculture, in sociology, in all departments of life. Our ignorance of the living creature is very great, and we can overcome our ignorance, not by theoretical discussions, not by dogmatical assertions, not by ingenious hypotheses founded upon insufficient knowledge. Progress, in my opinion, will come mainly from tracing out in the living creature the consequences of the broader generalizations found to hold in the non-living world of the exacter sciences, by the aid of the finer tools which they employ.

Physiology has three main functions—two very practical, one very philosophical. As the handmaid of medicine, and as the science of the behaviour of the normal living man, physiology has a great and practical part to play in national and social life. At the same time, however, physiology has its great intellectual part to play in attempting to describe the mechanisms underlying the manifestations of life; it is only this latter which we are discussing here. It may be asked what is meant by a mechanism, and how one would propose to study it. Before attempting to illustrate what I mean by a mechanism, let me give you a picture of a man as a community of a myriad living cells, each to some degree independent, each bound to the rest by ties of necessity, convenience, pride, comfort and inheritance. You—your personality as a whole—are the People, the Demos, the aggregate expression of the individual lives of all the little cells which make you up. You—your personality as a whole—express yourself more or less imperfectly by your representatives—the cells of your brain, meeting in parliament inside your skull. You—your personality as a whole—have a national pride and consciousness, expressed to some degree by your representatives. You decide, as a nation decides—goodness knows why!—to assault your neighbour. What happens? Your representatives, your government, the highly differentiated nerve cells of your cerebral cortex, interpreting your aggregate imperfectly expressed dislike of your neighbour, proceed to send a message to the various government departments—what we call the self-protective reflex centres (note that it is always self-protective)—ordering them to carry on. From that moment the War Office, the collection of reflex centres of the nervous system charged with "self-protection," proceeds to take charge of all the movements and activities of the community. Various lower and more automatic centres are called into play—corresponding to the various branches of the General Staff; and, finally, we come down to the individual fighting unit—the private soldier, the muscle cell with its simple functions, depending upon orders received along the nerves for its co-ordinated activity.

Now suppose that a nation is involved in such an affray, and that a visitor from another world has arrived with the intention of studying the organization and habits of the human race—a visitor who has never seen a man before and has not the least idea what he is like. He would not be wise, I think, to walk straight into Parliament, or into the War Office, or, indeed, into the Senate of this University, in order to study the organization in its full complexity; he would be much wiser, I think, to seek out an individual citizen, or an individual soldier, and to make a preliminary study of the simple common man. Having gained a conception of the behaviour of the simple common man, his need of sleep, of beer and tobacco, of oxygen, of companionship, his prejudices and his enthusiasms, he would be better fortified to proceed to study the organization of the State as a whole; for, after all, the properties of the State depend upon those of its fundamental unit—man. Similarly the properties of man depend upon the properties of the little cells of which he is built up, and his behaviour is the aggregate expression of their behaviour. Now, what properties have these cells? The outward manifestations of their properties are exclusively physical—they move, they divide, they take in food and water, they absorb energy and they give out heat; presumably there is some

cause for all these manifestations, so we attribute a mechanism to a cell. The mechanism of a cell is the cause, the means, of the physical manifestations of the cell's activity. In talking of a mechanism inside a living cell, in talking of the mechanism of life, one is not affirming that life is nothing but mechanism; one is assuming—what is obvious—that many of the manifestations of life are physical, and that these physical manifestations must have a physical cause.

Let us consider shortly the properties of the living cell, the unit of which the community of the living man is made. The living cell is very small—a million million or so to a cubic inch—and it is necessary to employ a microscope to study its structure. It is so small that most physical methods cannot be applied to the single cell—we have to employ a large number of similar cells at a time. It is surrounded by a membrane possessing certain physical properties. It contains a nucleus concerned in some mysterious way with the continued existence of the cell and its power of subdivision. It requires food and oxygen; it gives out energy and CO_2 ; it needs salts and water; and it shows many highly specific chemical properties. Some cells—the cells of the green plant—can absorb the radiant energy of sunlight and store it as the chemical energy of oxygen and starch; without this property of taking up energy from the sunlight the world would be a dead world, with no possibility of life and thought. The cell obeys—so far as we know—all the physical and chemical laws governing our universe. And yet it shows a kind of independence, a degree of complexity, an apparent purposefulness, which makes it difficult to fit into any simple physical system. We know, of course, that science is still very young; the theory of relativity and modern views of electro-magnetic phenomena tend to show that all our simpler conceptions of time and space, the laws of motion, of the conservation of energy and mass, are only good first approximations to some more fundamental reality. To assert that present-day physics can supply an account of the behaviour of the living cell is simply to state what is obviously not true; but will physical science ever be able to supply such an account? In the last resort I believe it will not. This, I admit, is only a belief and not based upon definite scientific evidence. In the last resort, however, I believe it will be found that the living cell, or some arrangement of atoms containing the same kind of purposive, selective properties, has existed as long as matter, that it cannot originate from matter alone, but always had another cell before it, and that in some kind of way, and to some degree, the spiritual nature of the universe is reflected in the behaviour, the life and structure of the living cell.

One function—the chief function—of science is the discovery and formulation of exact laws. Do not imagine that the so-called exact sciences have a monopoly of exactly obeyed laws. Biology, the science of the living creature, has several laws to which no exception has been found. Every living cell comes from a living cell: the offspring resembles the parent: all living creatures appear to have originated from some common stock in the very distant past: every organ has a counterpart in other types and species: certain characteristics are inherited according to exact mathematical rules discovered by Mendel and amplified by Bateson. These generalizations have the same dignity as the conservation of energy or the laws of motion. One side of the work of the biologist is to trace out and establish these generalizations of biology by the methods of biology, by the observation of the behaviour of living cells, their ways, their inheritance, their abnormalities. The task of the physicist and chemist, on the other hand, is to elucidate the general principles underlying the phenomena of the non-living world. The function of the physiologist lies between these two, to judge between the physical and the biological laws, to see how far the methods and generalizations of physical science can describe the phenomena of life, and how far it is necessary to invoke other laws—biological or psychological in nature but established like the former by careful and exact observation—to describe them.

I have purposely discussed so far the philosophical, the strictly scientific, side of the subject. The first duty of a university is to encourage the pursuit of knowledge, and knowledge can never be pursued profitably except by those who are primarily interested in knowledge for its own

sake. The "get-rich-quick" attitude will never work in science. Do not let me be misunderstood; I should be the last to discourage the useful applications of science or those whose interest lies primarily in such applications; I hold strongly to the belief that a knowledge of the theories and applications of science is a necessary part of any liberal education, and I feel that such applications—fitly and wisely and cautiously made—are an essential element in the progress of mankind. What I do wish to emphasize, however, is the fact that science will become sterile if we eliminate those—comparatively few—whose interest is primarily in the acquisition rather than in the application of knowledge. Those who need the encouragement and stimulus of a great university most are those who are in the firing line of the army which is promoting knowledge; without the units of the firing line the army cannot progress, necessary indeed as are those who follow behind to clear up, to consolidate, and to utilize the ground acquired. With this provision, however, let us consider a few cases in history where a study of the physical and chemical properties of the living creature have borne fruit in practical experience.

Pasteur investigating the optical properties of certain solutions was led to a study of the chemical properties of organisms, and thereby created modern bacteriology, modern knowledge of disease, modern hygiene, modern aseptic surgery: not to mention the fact that he saved the beer and silkworm industries of France. The world has never, I suppose, had a greater benefactor than Pasteur—on the material side the results of his work are to be reckoned in millions of lives and in millions of millions of pounds, and in the world of thought his discoveries are of no less value because, through them, disease has, to a large extent, ceased to be an unknown mysterious malignant spirit and become a matter which (though still unfortunately affecting the human race) is more or less understood, more or less a matter-of-fact plain thing. All this discovery and progress has resulted from Pasteur's interest in the optical properties of solutions.

Let us take another case. Here in Manchester, when a certain chemical body was urgently required in large quantities during the great war for the manufacture of propellant, bacteria were invoked to do what men found some difficulty in doing. In the future I think there is little doubt that manufacturing chemistry will come more and more in touch with biochemistry, and that more and more the chemist will employ strains of bacteria to deal with the molecule in an individual way impossible to his ordinary mass methods, and so to carry on processes which would otherwise be difficult or expensive. For example, a large part of the combined nitrogen, which is an essential constituent of food and an essential factor in chemical industry, is fixed for us by micro-organisms living on the roots of plants. Man has tamed the cow and the horse, the dog and the cat, till they have become an essential part of his social organization; in the future he will have to breed and tame the micro-organism and teach him also to minister to human needs.

Or take another case. When a muscle contracts, when a heart beats, when a nerve sends a message to or from the brain, certain electric currents are produced. The origin of these currents remains as yet a mystery, but the attempt to explain them has been one of the chief occupations of physiologists for fifty years. When you wish to do something you send a message to some muscle or group of muscles telling them to contract; this message goes 100 yards a second, 200 miles an hour—not as fast as a telegram, not, indeed, as fast as sound, but still many times faster than an express train. I called it a message, but what is it? Something goes along the nerve, some event, leaving nothing behind it, but causing the muscle to contract at the other end. The one thing we know about it is that this something, this event, this message is accompanied by an electric change: the elucidation of the mystery of this message will carry us far in describing the mechanism of life. But I am discussing practical applications. In order to study these electric currents, the Dutch physiologist Einthoven was led to design his string galvanometer, an extremely sensitive and rapid instrument for measuring and recording electric changes. This instrument has proved of recent years one of the most fertile agents in elucidating the problems provided by disease of the human heart. Most of us die in some way and in

some sense of heart failure in the end, so that anything which improves our knowledge of diseases of the heart may well be considered a useful application of physical, in this case of electrical, science to the living creature.

A study of the chemistry and physics of respiration, undertaken largely in an attempt to solve the purely scientific question of whether oxygen diffuses of itself into the blood through the lung substance, or whether the lung substance selects an oxygen, so to speak, and pushes it through, has led largely to the therapeutic use of oxygen in disease, to a knowledge of mountain sickness and of the effects of flying at high altitudes, to means of avoiding the disease known as caisson disease induced by working at high atmospheric pressure—as, for instance, when digging a tunnel under a river and to a study of the ventilation of mines and factories and submarines. A study of the chemistry of foods and of the things that happen to foods after they have been taken into the body, has led us to a knowledge of the vitamins—the so-called accessory food factors without which the animal becomes defective in vitality, mentality and development, without which a population may become the prey of rickets, scurvy or beriberi.

What further applications lie in front of us? The synthesis of a plentiful supply of foods adequate in all respects to maintain life for a continually increasing population: the more efficient utilization of the sun's energy: a knowledge of the mechanism of the cell—just as necessary to the wise physician as a knowledge of the mechanism of a watch to the wise mender of watches—the nature and production of specific immunity from disease: after all, is it really in the nature of things that all our children should have measles and mumps and whooping-cough? the production of chemical bodies with specific properties—like those of salvarsan—of destroying micro-organisms without destroying the body which they have invaded; the effects of radio-activity, of fresh air and sunlight: there is no limit to the practical applications of the study. Advance is coming quickly: with the aid of physical and chemical methods it is coming more quickly, but still not quickly enough. We want more workers, more apparatus, more laboratories and a wider scientific education of the people.

As I prepare to end this lecture, in which I hope I may perhaps have been privileged to communicate to others a little of my own pleasure in these things, I will revert once more to the interest of such investigations, as distinguished from their application. Mankind, one type of living creature, has been endowed with the power of thought and with an insatiable love of adventure. This love of adventure expresses itself in many cases in an insatiable curiosity as to how things work. It is a natural desire, and, I maintain, it is a good desire: it is a desire common to children of 5 and to old gentlemen of 80. How do things work? The living creature undoubtedly does work, in many and strange ways, but the problem of how it works is about the most difficult of all the problems man has ever set himself to solve. To solve it requires the highest experimental skill, the most delicate equipment, and a mind subtle enough to counter all the nasty tricks which the living creature will try to play on one. The problem is a very difficult one—how does the living creature work? But the difficulty only adds zest to the pursuit.

At the last German congress for internal medicine it was decided to establish an institute for testing the therapeutic value of new drugs.

Messrs. WILLIAM HODDER AND CO. will shortly publish in their series of Notable British Trials a volume dealing with the case of Burke and Hare, edited by Mr. William Roughhead.

THE first meeting of the International Congress of Urology will be held in Paris from July 5th to 7th, under the presidency of Professor Legtin, with Professor Verhooge (Brussels), and Professor Brongersma (Amsterdam), as vice-presidents. The subject for discussion are: (1) Nephritis, with uræmic syndromes; reporters, Hegro (Liège), Horder (London), Forbes (New York), Fessler (Lyons). (2) Remote results of wounds of the urethra; reporters, Kidd (London), Cardini (Bologna), Pasteau (Paris). (3) Pyelography; reporters, Lasio (Milan), Papin (Paris), Waters and Guy (Baltimore).

British Medical Journal.

SATURDAY, MAY 21st, 1921.

THE MACHINERY OF THE ASSOCIATION.

Nor all of those who read that section of the Annual Report of Council (printed in the SUPPLEMENT of April 30th) headed "Question of Efficiency of Constitution and Machinery of the Association" will realize the immense amount of work and experience which are there embodied, and for which the Association is indebted to Sir Jenner Verrall and his colleagues. The report could only have come from members who know much of the history of the British Medical Association and the changes its constitution has undergone during the past twenty years, and who are familiar with its working both locally and at the centre.

The object of the recommendations made is to bring the machinery of the Association up to date, and though the report is long it is not so formidable as it looks. Many of its numerous recommendations merely dot the i's and cross the t's, being verbal amendments of Articles and By-laws designed merely to remove obscurities. Others suggest relegating to the head office some of the detail work which has hitherto been done in part by the honorary secretaries of Divisions and Branches. An important subdivision of the report seeks to increase and define the responsibilities of Branch Councils. Before the present constitution was adopted in 1903 there were no Divisions and all the local work of the Association was done by the Branches in general meeting and by the Branch Councils. The scope of that work varied in accordance with local conditions and the energy and initiative of the Branches. All of them held clinical and scientific meetings, and all in varying degrees cultivated the social side. A few paid attention to medico-political questions and some dealt with ethical disputes. With the inauguration of the Divisions some of the Branch Councils which had hitherto been active felt that much of their *raison d'être* had gone, and their tendency has been to become bodies whose only concern with the Divisions in their areas is to distribute to them the grant received from the Central Council. But others have always felt it to be their duty to act in a sort of parental capacity to the Divisions in their areas, to try to co-ordinate their action so as to level up the local standards of remuneration and conditions of practice, to serve as arbiters in ethical disputes, and to stimulate those Divisions whose activity fell below the general level. The Council has come to the conclusion that all Branch Councils should be expected to take this view of their responsibilities. It is therefore recommending that all Division secretaries should be *ex officio* members of the Branch Council, that the Branch Council shall actively co-ordinate the work of the Divisions in its area, calling joint meetings of any of its Divisions to consider matters of common interest, and shall apply itself to the reorganization of any Division which may have become inactive, and act for such Division pending reorganization. As a corollary to this the Council proposes to take power to organize any inactive Branch, and to act for it, pending its reorganization. Realizing that no Branch or Division

can be really effective which has not adopted organization and ethical rules of procedure, it is proposed that no new group of members shall in future be recognized as a Branch or Division until it shall have adopted such rules, and that as regards existing Branches and Divisions the names of those which have not adopted such rules shall be reported annually to the Representative Body.

Another group of recommendations deals with the Representative Body; their tendency is to impress on Divisions the importance of exercising their right to appoint representatives. It is proposed to shorten the time within which representatives can be appointed; to provide that notice of election of representatives must be sent to the head office not less than six weeks before the Annual Representative Meeting; to impose on the constituencies the duty of electing deputy representatives; and to empower the Council, whenever it thinks desirable, to give separate representation to Divisions which have fewer than the standard fifty members. No one of the proposed changes is individually great, but collectively they will, if adopted, tend to accentuate the predominant position of the Representative Body in the constitution of the Association. In connexion with this section should be noted that part of the report which deals with the power of referendum to the Divisions where the Council differs from the opinion expressed by the Representative Body. The Council has carefully examined the present machinery and has presented an analysis of it. It has come to the conclusion that the only change to be recommended is one which makes it necessary for the Council to decide whether it will take a Referendum or not within one month of the meeting of the Representative Body, instead of, as at present, within three months. The change is one of form rather than of substance, for at present the Council meets immediately after the Representative Body and would undoubtedly make its decision on a matter of such importance without the delay even of a month.

The most striking change proposed in the report is in regard to the method of election of the Central Council. The Constitution Committee of 1900-2 was sharply divided as to whether the Council should under the new constitution be directly elected by the Representative Body or continue to be elected by the votes of members of Branches, singly or in groups. There is, of course, much to be said for the view that the Council is responsible to the Representative Body, and should be directly elected by it. To some this seems the strictly logical view, but in constitutional matters sentiment is often quite as important as logic. Moreover, the Branches have always elected some of the members of Council, and many members are averse from giving up this local election, in which every individual member can if he choose take a part, in favour of an election by the Representative Body acting as an electoral college. The result in 1903 was a compromise. The Representative Body has for some years elected 16 members of Council—12 by representatives grouped geographically in 12 groups, 4 by the representatives as a whole. The Council now proposes that these 16 shall be elected as follows: 12 by the representatives of England acting together, 1 by the representatives of Ireland, 2 by the representatives of Scotland, and 1 by the representatives of Wales. This, it will be seen, is a step away from the more localized grouping hitherto adopted, and if approved will diminish an objection often brought against the present method of election by the 12 groups—namely, that the number of representatives in the group is too small

to be a satisfactory electorate, and that the method unduly restricts the choice of the meeting. It will be noted that the election by postal vote of 24 members by grouped Branches is untouched, as is also the election of members of Council by Oversea Branches. Other proposed changes in the Council are to make the outgoing Chairman of Representative Meetings *ex officio* a member of Council for one year after he leaves the chair and to make the Deputy Chairman of Representative Meetings *ex officio* a member of Council.

The last large section of the report deals with the Committees of the Association. It proposes to make more precise the references to most of the Committees, to decrease the size of the Finance Committee while increasing that of the Journal and Science Committees, and so to alter the method of election of the Science Committee that 4 of its 10 members will in future be elected by the Representative Body instead of all being elected by the Council. Besides this, power is given to Committees to consult each other directly instead of, as at present, indirectly through the Council, and to any Standing Committee to co-opt persons who may be thought specially qualified to assist the Committee in its work.

None of these changes are to come into operation at once. The intention is that the Representative Body shall freely express its opinion this year on the changes proposed; such of them as are accepted will be placed formally as new Articles and By-laws before next year's Annual Representative Meeting. There can, therefore, be no fear of hasty and ill-digested changes in the constitution.

Those who study the report will be struck with the fact that a careful and long-continued scrutiny of the existing constitution and machinery of the British Medical Association by a body of experts who were by no means prejudiced in favour of leaving things alone has resulted in a report which recommends no revolutionary changes and which expresses the deliberate opinion, endorsed by the Council, that on the whole the present constitution has proved well suited for carrying out the objects of the Association. It remains to be seen whether the Divisions and Representative Body are also of this opinion, and how far they think the changes now suggested will tend to make the Association still more useful to its members and to the profession.

THE MINISTRY OF HEALTH.

THE vote to complete the estimate for the Ministry of Health had a quiet passage through the House of Commons last week. Sir Alfred Mond, on beginning his speech, appealed for consideration because of the newness of the Ministry and the difficulty of its task, and in concluding it spoke of a time when disease would be a thing of the past and illness a kind of forgotten tradition. While agreeing that the Ministry has a great future in helping the nation towards higher standards of health and physical development, we think it will be prudent at this stage not to promise too much. Dr. Farquharson again directed attention to the disappointing results of sanatorium treatment when compared with the glowing promises of twenty years ago, and expressed the opinion that it would be impossible to have a tubercle-free population in this country. Without attempting to adjudicate on a matter so complex and uncertain, it may be said, without fear of contradiction, that the facts about tuberculosis illustrate the point we desire to make. It would, we think, be both wise and politic, even

in a peroration, to impress on the public mind the truths that the increase of industrialism and of the population in urban accumulations are constantly making the preservation of health and the prevention of disease more difficult, and that, if things are not to grow worse, the hearty and intelligent co-operation of the individual as well as the expenditure of public money are necessary.

A good deal of the short time the House gave to the debate was spent in getting at the truth about a fairly simple matter of fact—namely, the number of medical officers Dr. Addison had appointed to the Ministry. By counting in the regional medical referees or consultants appointed under the Insurance Acts, which was perhaps fair, and by reckoning the medical inspectors of the Local Government Board who became medical officers of the Ministry of Health as new appointments, which certainly was not, the *Times* got a total of 50 new appointments and of about 100 medical officers altogether. The official calculation by omitting the regional referees gave a net increase of 13 and a total of 59 medical officers. Technical justification for the omission of the referees is found in the fact that their appointment was approved by Parliament in 1914 but suspended during the war; but in any case to get a true comparison they should be excluded, for the work of the medical department of the Local Government Board had nothing to do with the Insurance scheme. Of the new medical officers six, Dr. Addison states, were appointed to reinforce the staff dealing with the prevention of the spread of epidemics and kindred matters, especially with a view to the requirements of the sanitary cordon urgently necessary in the post-war period; from what Sir Alfred Mond said it would appear that the reference is to the port sanitation work in which the central authority can give essential help, as was long given by the Local Government Board. It may be true that in this and other directions the Ministry is not yet doing much more medical work than its predecessor, but it seems obvious that a Health Ministry must have an adequate medical staff if it is to be as useful as the country has been led to expect it will be. The charge of extravagance in this matter of the appointment of medical officers has broken down completely.

Sir Alfred Mond, like his predecessor, feels the oppression of the housing problem, but could say that though there was a shortage of certain classes of workmen good progress had been made; cost had decreased a little and local loans had been raised without difficulty. In spite of all this, each house erected by local authorities is to cost the State £50 more a year than its rent, so that the best news the Minister had for the tax-payer was that the estimate originally made in many districts of the number of new houses needed had proved to be enormously beyond the actual demand. Anyone who a year ago had hinted at an over-estimate would have been called reactionary, and the reduced estimate is not now accepted by the National Housing and Town Planning Council; Sir Alfred Mond spoke of an ultimate gross number of 300,000 new houses of different classes, but the Council would appear to adhere to the estimate of a million houses for England and Wales alone. This estimate was founded on the results of the housing survey made under conditions laid down by the Ministry of Health, but did not, perhaps, take sufficient account of the possibility of repairing old houses—often much better built than modern—and rendering them habitable and healthy.

Not very much was said about National Insurance. The new Minister stated that he had begun by doubting whether the regional referees were necessary

but had been convinced of their utility. Sir Watson Cheyne expressed the opinion that the panel could be improved if it were made easier for the insured person to change his doctor so as to encourage competition, and the Minister agreed. Another proof is thus afforded of the wisdom of the policy of the British Medical Association in insisting on free choice of doctor. Sir Watson Cheyne's remarks also drew from Sir Alfred Mond the statements that the establishment of a State medical service was not in contemplation, and that he did not think anyone wished to destroy the voluntary character of our hospitals. In this opinion we fear he is mistaken; but it may be deduced that he is himself anxious that the voluntary system should be maintained.

The general impression produced by his share in the short debate (of which a full account appears in our Parliamentary Notes this week) is that Sir Alfred Mond is disposed rather to allow things medical, so far as he is concerned with them, to follow the natural line of development than to endeavour to bend them to conform to any theoretical preconceptions.

THE PROBLEMS OF INDUSTRY.

THE newspapers are filled with the tale of labour troubles and struggles, but these accounts reveal only a one-sided appreciation of the magnitude of the problems involved and the efforts that are being put forth to secure both better and more efficient working in industry. To the student of these problems two books recently issued may be commended. One by Archibald Chisholm,¹ entitled *Labour's Magna Charta*, is a critical study of the labour clauses of the peace treaty and the draft covenant and of the recommendations of the Washington International Labour Conference; it is exceptionally well written and sets out the economic problems of international labour in a lucid and interesting manner. Considering only those parts of the work which have a distinctly medical bearing, we note how far-reaching is the influence of physique, hours of work, food, and fatigue. Physique as a factor in industrial efficiency is of prime importance. Chatterji is quoted as declaring that Indian labour is really dear, though wages are low. He stated that if an English mill engaged on a similar work were compared with an Indian mill it would be found that, while a much greater number of employees were engaged in India, the output would not be worth more than 65 or 66 per cent. of the value of the English output. This low efficiency applies to child labour and to a lesser extent to female labour. As a means of meeting the needs of women who must work, reference is made to a "half-time" system which has been in operation for some years in the United States, and has been applied also to apprentices. While the great majority of workers are engaged all day, some work from 8 a.m. until noon. One great firm declares that it has found the system so successful that it is prepared to adopt it on a large scale. Industrial fatigue is, of course, another factor in efficiency. It is defined as "a condition of lower capacity for work which follows or occurs during the performance of work, of which it is the direct result." It may exist, therefore, without weariness. Under the Taylor system, whereby causes of fatigue are largely reduced, the workman's output has been found to increase by as much as 60 to 100 per cent., and in addition a considerable saving of material has been effected. The influence of fatigue upon efficiency is readily appreciated by the doctor who type-writes his own letters and compares the number of mistakes made in the evening after a hard day's work with his morning performance. Adequate food is another important

factor: the better-fed worker is usually the more efficient. It is said that figures show that before the war Germany consumed 20 per cent. more food in proportion to the number of industrial workers than the United Kingdom, and France 15 per cent. more. Mr. Chisholm quotes an interesting speculation of Dr. Ellsworth Huntington which suggests that health is a greater determinant of trade cycles than the condition of crops. For every death, he holds, we have about ten cases of severe illness, and owing to the disorganization of industry caused by deaths and sickness, bad trade ensues. He endeavours to show that a high death rate regularly precedes hard times, and that a low death rate is followed by a period of prosperity. The relative inefficiency of Indian labour may be connected with a high death rate, for the average duration of life in that country is given as only 23.5 years. The second work is a massive volume by Dr. René Sand² on industrial organization, social medicine and civic education in England and the United States. The book is the result of three personal investigations made in these countries in the years 1918-19, the first at the instance of the Belgian Government. His journeys were extensive, his investigations most thorough, and the results are of great value. The primary object of his visit to the States was to make a study of "Taylorism," which has a wide vogue in that country and to a lesser extent in Europe. At present it seems to be the last word in industrial progress, and may be epitomized as the application of the science of organization to production. The physiology, psychology and social condition of the worker are studied, for in their improvement is found the key to efficiency. The health of the worker must be assured, or else he cannot do good work. General and professional education must be high, so that talent may be developed. Contentment must be secured, for that determines the wish to work. The author has collated the efforts that are being made to attain these ends by great industrial organizations, and he shows how extensive and far-reaching are the effects already secured. A compilation of this kind is of great value to those engaged in industrial and State medicine, and presents points of interest to every practising physician. On page 478 is a most dramatic diagram, in which the infantile death rate is correlated with the annual income of the father. With wages less than 150 dollars the death rate is 170 per 1,000, at 500 dollars it has fallen to 130, at 700 dollars to 108, at 1,000 dollars to 80. A like correspondence is found between wages and the health of the workers. One of the conclusions to be drawn from the evidence of these two books is that low wages mean poor work and a more costly production than high wages. The economic failure is further aggravated by the drain on the public purse due to the piling up of costly remedial expenditure that could be better utilized in more remunerative forms of medical and sanitary provision.

ROYAL SOCIETY CONVERSAZIONE.

THE annual conversazione of the Royal Society was held at Burlington House on May 11th, and was so well attended that it was practically impossible to see a tenth part of the exhibits and demonstrations. Fortunately arrangements are always made for an earlier press view of the latter. This year amongst the thirty-nine demonstrations figuring in the catalogue there was none having any direct bearing on medical science, though the exhibition contained much of great general interest. Mr. L. T. Hogben, of the Imperial College of Science, demonstrated the effects on tadpoles by feeding them with pineal gland. Hitherto there has been no proof of any physiological function exercised by the pineal body, but Mr. Hogben has succeeded in showing, in tadpoles at least, that it has some controlling power over the pigment cells. Macroscopic

¹ *Labour's Magna Charta*. By Archibald Chisholm, M.A. London: Longmans, Green, and Co. 1921. (Pp. 192. 8s. 6d. net.)

² *Organization Industrielle, Médecine Sociale, et Éducation Civique en Angleterre et aux États-Unis*. By Dr. René Sand, of Bruxelles. Paris: J. B. Baillière et Fils; Bruxelles: Librairie Lamertin. 1920. (Roy. 8vo, pp. 896. 50 francs.)

and microscopic preparations showed that in the pinealed tadpoles there is a very evident contraction of the melanophores, an effect that is not produced by feeding experiments with any other endocrine organ. Mr. C. Tate Regan, F.R.S., gave a demonstration of part of the life-history of the common eel, founded on the researches of Dr. J. Schmidt, who showed that the freshwater eel of Europe breeds in the Atlantic, south-east of Bermuda. A series of larvae, from the middle and western North Atlantic, with long and slender pointed teeth, were exhibited, together with a photograph of the metamorphosis into the elver. The accompanying models illustrated the changes from the yellow eel with its thick lips, small eye, and compact pectoral fin, into the thin-lipped, large-eyed silver eel with pointed pectoral fin, the latter form of eel being that which migrates to the ocean to become mature. Dr. John Rennie demonstrated the mite, now named *Tarsonemus woodi*, which has been claimed by Bruce White to be the causal agent of Isle of Wight disease in bees. White showed that the mites perforate the tracheae, and by their numbers obstruct the spiracles and thus deprive the bees of the power of flight. Mr. J. E. Barnard gave a demonstration of the microscopic appearances of sections by ultra-violet light. Certain structures, owing to their differences in chemical composition, give different fluorescent tints, and the images obtained are often dissimilar to those obtained by ordinary staining methods. The light filter used was a glass made by Chance, which is transparent to the ultra violet radiations, and the quartz substage condenser was of the "dark-ground" type. A most interesting and instructive astronomical model designed for educational purposes was exhibited by Dr. William Wilson. This model, which has received great praise from leading astronomers and teachers, not only demonstrates the more familiar motions of the sun, earth, and moon, and the various phenomena resulting therefrom, but is capable of simple analyses of each particular motion. The apparatus is most ingenious.

NORTH EUROPEAN CONFERENCE ON VENEREAL DISEASES.

THE first North European conference on venereal diseases opens to-day at Copenhagen, under the auspices of the League of Red Cross Societies. Besides the Danish Red Cross Society, which is acting as host and convener, the conference will be attended by representatives of the following national Red Cross Societies: Great Britain, Holland, Norway, Sweden, Finland and Germany. The Governments of these countries will also send delegates. The results of the all-America conference on venereal diseases, held at Washington in December, 1920, will be presented to the Copenhagen meeting by Lieut.-Colonel Ritchie, Assistant Chief of the Division for Combating Venereal Diseases, League of Red Cross Societies. The conference will be opened by the chairman of the Danish Red Cross, Professor Høffding, after which Sir David Henderson, Director-General of the League of Red Cross Societies, will deliver an address. A general summary will be given of the conditions in each country, and the medical and educational measures against venereal diseases will be discussed. The following special problems are to be presented: (1) The supply and cost of arsenical compounds for the treatment of syphilis: the possibility of establishing an international standard for the export and import of such compounds: discussion to be opened by Dr. Kristian Grøn, of the Norwegian Red Cross Society. (2) The provision in important ports, by international agreement, of facilities for the treatment of venereal diseases among sailors and measures to be taken in connexion therewith: discussion to be opened by Colonel L. W. Harrison. (3) The part of the Red Cross in combating venereal disease, its relation to government and voluntary agencies: discussion to be opened by Professor C. E. A. Winslow, of the League of Red Cross

Societies. (4) Medical measures for the prevention of venereal diseases: discussion to be opened by Dr. Jersild, of the Danish Red Cross Society. Following this meeting at Copenhagen, the League of Red Cross Societies expects to arrange other conferences of groups of nations, both in Europe and in other parts of the world.

THE HARROGATE WATERS.

PROFESSOR ARTHUR SMITHELLS, C.M.G., F.R.S., has completed the survey of the Harrogate waters entrusted to him four years ago. He has been assisted by Mr. W. Lowson, B.Sc., F.I.C., lecturer in analytical chemistry in the University of Leeds, where Professor Smithells occupies the chair in that subject, and also by Professor Bragg, F.R.S., who was responsible for determinations of the radio activity of the waters; by Professor P. F. Kendall, who reported on geological questions; by Professor Goodman, who advised on engineering problems; by Mr. G. R. Thompson, B.Sc., formerly Professor of Mining, and by Professor J. W. Cobb, B.Sc., F.I.C. Details of the results obtained have not yet been published, but we are informed that the analyses when compared with previous records show that the special characteristics of the Harrogate waters are fully maintained. Improvements have recently been carried out which have led to an increase in the sulphur content in the sulphur bathing waters; the storage loss can now be kept at the remarkably low level of 5 per cent. The Harlow Car alkaline sulphur water used in skin diseases, hitherto only available at its source two miles from Harrogate, has now been brought to the Royal Baths, the difficulty of transmission without deterioration having been overcome. Mr. Arnold Woodmansey, M.Sc., has been appointed full-time analytical chemist to the Harrogate corporation to supervise the collection, storage and distribution of the mineral waters. He has demonstrated the presence of manganese in all the chalybeate and most of the sulphur waters, and it has been shown that the barium content of several of the wells has been increased, in one instance by as much as 50 per cent. The British Spa Federation has instituted a system of training for bath attendants; persons attending the balneological training school at Harrogate are required to have had a minimum of eighteen months' practical work at one of the spas of the Federation, and to have attended a series of lectures given by members of the local medical profession; they are then submitted to a primary examination. After further practical work on specialized and more difficult treatments, and a further series of lectures, a candidate is eligible for the final examination. Nearly all the members of the Harrogate Baths staff have attended lectures during the past winter and have passed the primary examination. It is expected that next winter a considerable number of candidates from other home spas will attend the course.

THE UNMARRIED MOTHER.

THE aims and needs of the National Council for the Unmarried Mother and her Child were put forward at an "At Home" given by Dr. Mary Scharlieb at her residence on May 12th. The object of the National Council is to correlate the work now being done on this subject all over the country, and to influence public opinion in favour of the bill which has been prepared by the Council. Captain G. E. W. Bowyer, M.P., is in charge of this measure, and is keenly endeavouring to obtain a second reading for it in the House of Commons. The main features of the bill—which was introduced last year by Mr. Neville Chamberlain on the Council's behalf—are that proper responsibility for the illegitimate child should be placed upon the father, and that subsequent marriage should legitimize children from the date of marriage. Besides the work involved in trying to amend the existing law, the Council is carrying on a great deal of educational work throughout the country. While at first it did not consider that dealing with actual cases came within its programme, a deaf ear could

not be turned to the individual cases of hardship which have come to its notice, and the care of unmarried mothers and their children is now included within the scope of its activities. Maternity homes are found for expectant mothers, hostels for mothers and children, and work is found for mothers, with the object, if possible, of keeping mother and child together; for no longer in these more enlightened days is it thought desirable to separate mother and child in different institutions, as used to be done. When it is realized that 80 fresh cases were dealt with last month by the Council, and that the number of illegitimate births in England and Wales last year was over 42,000, the necessity for the work of the National Council is obvious. Unfortunately, with the increase in unemployment, the difficulties in placing mothers in suitable employment have increased. At Mrs. Scharlieb's meeting the excellent work that the National Council is doing was made clear, and its financial needs were ably pleaded. Its efforts to bring the law of England on illegitimacy into line with that of other civilized countries, and the educational and charitable work it is doing, are worthy of increased support.

THE TREATMENT OF ALCOHOLISM.

In his last annual report to the Homes for Inebriates Association, Dr. F. S. D. Hogg gives an account of the year's work at Dalrymple House, Rickmansworth, of which he is the medical superintendent. Certain of his general conclusions, based on a long experience of the institutional treatment of alcoholism and drug addiction, seem worthy of note. Thus he considers that admission under the Inebriates Act is the best course both for the patients and their friends in a large number of cases. No kind of distinction is made at Dalrymple House between either class, but while private patients can end their stay at any time, and sometimes do leave prematurely without giving themselves a chance of success, those under the Act must remain in residence until the period for which they have signed expires, unless they are previously discharged, or go away on leave of absence under the Act. The last-named procedure he finds a useful method of practically discharging a patient while still keeping in touch with him and being in a position to help him and his friends should a relapse occur. In regard to treatment, Dr. Hogg says: "I continue to adopt no single form of drug therapy in all cases, for I know no treatment that is universally applicable. Each case has to be studied, and such treatment as is considered appropriate is adopted. Alcohol is given at first to those who require it, but after the first two or three days it is rarely demanded; for drug habitués gradual reduction is usually employed. My object is to wean a man from alcohol, or from the particular drug for which he has an addiction, with as little discomfort to him as possible." This, we believe, represents the opinion of those, in this country at least, who are in the best position to judge. Most authorities will probably also agree with the view here expressed that, when the poison has been withdrawn from the patient's system, the next step is to cure him when possible of any diseased condition that may be at the root of his drink or drug impulse, and restore him to a sound physical condition. Thereafter the object is to train the patient's mind to resist the morbid impulse by cultivating his self-control, strengthening his will power, and making him realize that part of his cure lies in his own hands. Above all, the inebriate and the drug slave must be made to understand that abstinence is an absolute necessity. The first principle in the treatment, not only of dipsomania and pseudo-dipsomania, but of chronic alcoholism as well, is total abstinence. As has been well said by a writer on this subject, it is idle for the drunkard to hope that he can ever drink habitually in moderation. With regard to liberty to leave the grounds of the institution, Dr. Hogg reports that a considerable amount of freedom can be given to some patients within a few days of admission, and after

two to four weeks' residence the large majority can be given parole. His patients are all males and mainly, if not wholly, drawn from the upper and middle classes, and this experience, therefore, may not quite coincide with that of the medical superintendents of all inebriates' retreats.

THE HISTORY OF MEDICINE.

The second Congress of the History of Medicine will be held in Paris during the first five days of July under the presidency of Professors Jeanselme and Menetrier. The congress will be opened at the Faculté de Médecine at 9 a.m. on Friday, July 1st, by the Minister of Public Instruction, and discussions will take place on the afternoon of that day and the four following days. The subjects chosen are the history of hospitals and of public provision for the sick in all countries; the diet scales of man and the diet of animals in antiquity and in the middle ages; the history and nature of the great historical epidemics; the part played by pharmacists in the development of biology, and the history of epizootics. Visits will be paid to hospitals, museums, and central hospital pharmacies. After the closing session on Tuesday there will be a reception at the Hôtel de Ville. During the congress an exhibition will be open containing manuscripts, books, engravings, paintings, medals, and instruments of historical interest. The subscription—40 francs for members and 20 francs for members' relatives—should be sent to M. Fosseyeux, 3, Avenue Victoria, Paris.

Medical Notes in Parliament.

[FROM OUR PARLIAMENTARY CORRESPONDENT.]

The Ministry of Health.

SIR ALFRED MOND'S DECLARATION OF POLICY.

IN Committee, on the vote for £15,245,098, Sir Alfred Mond made, on May 12th, the annual statement on behalf of the Ministry of Health. Recalling that the Ministry was established as recently as the year 1919, and that it had taken over the already heavy burdens of the Local Government Board, National Insurance, and the development of health, and had had placed upon it the responsibilities of housing, he pointed out that comparisons between the expenditure of the Local Government Board and that of the new department could not fairly be made. In spite of their difficulties, the Ministry had reduced the estimate by £3,300,000 as against what it was last year, including what had been saved in the stoppage of war services. There was an increase on administration of £594,000, an increase in housing grants of £251,000, an increase on miscellaneous health services of £970,000, a decrease in insurance grants of a considerable sum, and a decrease on special services arising out of the war of £7,000,000. It should be borne in mind that a great part in the increases and decreases in the grants resulted automatically from legislation passed by the House, and especially from the operation of the National Insurance Act. For instance, about £8,000,000, representing grants in aid, payable under the National Insurance Act, were not subject to change by the Minister. He explained also that a considerable sum in respect of the establishment represented an expenditure on services delayed by the war, and of a temporary character. In regard to housing, Sir Alfred Mond said that his position reminded him of that occupied by some remote ancestors of his in the land of the Pharaohs some few thousand years ago, who were asked to make bricks without straw—the trouble in the present case was to find the money. The situation on May 1st was that they had 176,000 houses under approved tenders, 160,000 under signed contract, and 102,000 houses in course of construction. The amount of skilled and unskilled labour had risen from 129,000 on October 1st to 130,000 on May 1st; they were completing nearly 6,000 in April, and would complete nearly 7,000 a month hence. Partly, as he believed, on account of the depression local authorities were greatly reducing their estimates of requirements, and the Minister hazarded the view that this might be because many people seeking houses a year or two ago might be contemplating emigration. But, on the best estimate of reviewed arrangements, the loss to the State on each house erected by local authorities under the present scheme would be about £60 a year, and that put

into the terms of 200,000 or 300,000 houses meant a net loss to the State and burden on the taxpayer of between 12 and 18 million sterling a year. In addition, a grant of 15 million had been voted for the private builders' subsidy, and there were other heavy obligations. He was glad to say that the price of houses was coming down. Tenders for the average-sized house had come down from £950 in August to £855, and they were still dropping. Roughly speaking, he regarded 300,000 as the limit for the number of houses to be built in England and Wales under these conditions, and if they could get along with less he should cut down the figures. In closing the review of this part of his work the Minister described housing as a kind of cuckoo's egg laid in the nest of the Ministry of Health which had pushed little chicks of health out of the nest.

Coming to what he described as being really the work of his department—that was considerations of health—Sir Alfred Mond dealt first with a criticism in the press on the medical establishment of the Ministry. He said that, whereas the old Local Government Board had a relatively small medical staff, and comparatively few medical duties, the National Health Insurance had a much larger staff, and when the two were joined together that automatically increased the staff of the Ministry of Health. On April 1st, 1919, the number of pensionable medical men in the Local Government Board and the Insurance Commission of England and Wales was 46, the number in the Ministry of Health at present was 59—that was a difference of 13 distributed as follows: Maternity and child welfare 2, tuberculosis 2, venereal disease 2, port isolation hospitals 3, statutory medical service and intelligence work 3, and work for the Home Office 1. These were additional functions to the work which was being looked after by the medical staff of the Ministry of Health, apart from the newly-established regional officers. He thought it was not quite realized how big was the sanitary work the department supervised. No fewer than 1,800 sanitary authorities, 114 port authorities, 646 Poor Law Unions looked to it for guidance, and 1,029 isolation hospitals and 4,220 public vaccination districts had to be inspected. There was a vast number of maternity centres and tuberculosis sanatoriums also requiring attention. He had stated why the increase in the medical staff of the Ministry had taken place; they were not up to their full establishment on the medical services, and he did not propose to fill the two vacancies at the present time. There were also some six temporary appointments the work of which had lapsed, and he intended to discontinue them. He understood there would be the possibility of the reduction of two more of the permanent established staff, so there would be a reduction altogether on establishment and non-establishment of between nine and ten. That was as far as they could wisely go at the moment in the direction of economy in this very important service, upon which so much depended and so much more would depend in the future. He was glad to say that the health rate of the country was good and the birth rate was rising and the death rate declining. Particularly marked was the continued steady decline of infant mortality. No one who had seen the maternity and infant welfare work could doubt the services rendered. He remembered what was perhaps the first centre or home of this kind in the world, which was started in his own constituency by his wife many years ago. Any one who had seen how much good a relatively small institution, wisely guided, could do would certainly wish to see the work extended all over the country. He was glad to say that the number of health visitors had gone up from 1,400 to 1,700, the number of non-resident centres had risen from 1,400 to 1,900, the number of maternity homes had gone up from 740 to 1,200, and the infant hospitals for children under 5 years had risen from 50 to 367. Whatever economies they might be forced to make, he hoped that they would not economize on the infant life of the country; that would be the poorest and most miserable economy.

They were making good progress in dealing with tuberculosis. The work that had been done was beginning to bear fruit—the first-fruit of the work done by the Ministry of Health and by the enthusiasm and zeal of his predecessor in office, who had so much special knowledge of the subject. They might achieve relatively little at the time, but they could be confident that, if they proceeded on reasonable lines of care and treatment, if they proceeded on the lines of teaching people about hygiene and how to avoid the disease rather than dealing with it only when contracted, they could produce a great improvement in the standard, physical and therefore moral, of this country. It was the best investment the country could make, for after all the greatest curse and unhappiness was ill health.

He was glad to say that venereal disease work was

making good progress. While he did not believe in covering the country with posters to draw attention to the evil and over-emphasize it, he was quite convinced that they must steadily proceed with propaganda and with treatment. He was considering now the issue of a new circular to explain the policy of the department, which consisted of a sane and moderate view of this very complex and difficult problem, which had a moral and social as well as a medical side. The moral and social side should never be overlooked; it was more important in some respects than the medical. While quite prepared to assist to have the health of the nation protected against this very terrible disease, he was not prepared to accede to the demand of those who seemed to him to regard the question with perfect sincerity and great enthusiasm—merely from the aspect of the medical cure without taking the wider view.

Sir Alfred Mond next referred to the establishment of medical referees in connexion with National Health Insurance work. The appointment of some thirty-three whose duties were largely connected with the examination of members of approved societies, had been criticized in the press; but these appointments were really made as long ago as 1914 by the House. It was no new fantastic idea which had been elaborated, but the redemption of an old pledge. The object in the main was that approved societies should have an independent and carefully chosen man in each area, to whom they could submit cases in regard to which they were doubtful whether such cases ought to remain on the books or were to resume ordinary occupations. It was very difficult sometimes to determine whether a man was malingering; there was a danger—he would not say a bias—on the part of the man's medical attendant to give him the benefit of the doubt, but it was in the interest of everyone that a man should return to his normal life as quickly as possible. When he entered upon his office he had some doubts as to the ability of these medical referees, and he asked six of them from different parts of the country to come and have a talk with him. He was very much impressed with the value of their work and of the way in which their work was being appreciated, both by the approved societies and by the most intelligent of the ordinary general practitioners in the district in which they worked. They acted also to a considerable extent as consultants, and were ready to act in such capacity to the panel doctors when the latter had more than ordinary difficulty. He believed that their presence was welcomed by the medical profession as a whole. They were engaged only as an experiment for a certain number of years, but were performing good and useful work, and it would be a very great mistake, under the pressure of clamour or prejudice, to do away with a very fruitful source of development of this work by men very carefully chosen and very able, before there was time to judge how far the work would be of utility.

He believed there was a great future before the Ministry of Health. He regretted very much that one of its important sections, namely, research, had been detached; he hoped it was going to be joined on again, for that was one of the most fruitful sources of developments. There were many other matters on which he would have liked to speak, but he would say broadly that he would try to extend those activities which would bear most fruit at the least expense and show the greatest amount of good. He should deplore beginning his economics at the wrong end. Such a course would be like that of people who, when they did not feel well, took some patent medicine and so got thoroughly bad, and then had to spend months under the doctor and pay a bigger bill than if they had started with him. There were so many false economies. A friend broke his leg in running after a motor bus, when it would have been much cheaper to have taken a taxi. They must not carry such policy into their national life, but must have a wide vision for the future. He felt his responsibility very greatly. He recognized there was a great work to be done, and if they could assist to put a few small stones in the great building of national health and national wealth he should indeed be glad.

Debate.

In the course of discussion Mr. C. Edwards brought up the complaint made by members of the Standing Joint Committee of the Industrial Women's Organization who were appointed on one Consultative Council. They said that in the first instance their reports were mainly ignored, and that afterwards the Council was not called together. Orders were issued by the Ministry without any reference to such Councils for an opinion. Women members of the councils were so dissatisfied with what was being done that they sent in their resignation.

Colonel F. B. Mildmay, after a tribute to Dr. Addison for his sympathy with voluntary hospitals, expressed his confidence in the Committee presided over by Lord Cave, whose final report was shortly expected. He asked the Government, however, to appreciate that many of the principal London hospitals were already in financial crises. The London Hospital management was being compelled to close two hundred beds at once, though 761 poor people were waiting for admission. Lord Knutsford had told him that the hospital was getting further into debt at the rate of £2,000 per week; King's College Hospital was, he understood, being forced to close 150 beds; St. Thomas's was being forced to close a hundred, and so on. At the Middlesex Hospital, with which he was associated, they had been obliged to get an overdraft for £15,000, against which their securities were pledged, and, even supposing that legacies were maintained in the coming year at the normal height, they would be adding to their debt at the rate of £3,500 a quarter, and by the end of the year would have exhausted their credit. He agreed that Sir Alfred Mond could not anticipate the report of Lord Cave's committee, but did suggest that he might make one helpful move. The financial difficulties of Middlesex Hospital were due mainly to the treatment of naval and military patients during the war. These occupied three fourths of the beds during that period, and the cost to the hospital was £32,000 more than the Government paid. Surely that might be claimed as an ordinary debt. The figures had been checked by the hospital accountant and the auditors of the King's Fund. If this sum were repaid the hospital would be freed of debt, and they would have breathing space. If it could not be liquidated without delay, let the debt be acknowledged, and they would be able to borrow money against its acknowledgement. Lord Hambleden had expressed himself in the same sense at King's College Hospital, and other hospitals were in the same condition. They were not asking for a subsidy, but for payment for services rendered. It was the immediate difficulties which were daunting them. He looked upon the financial future of hospitals as fairly hopeful. The system of payment by patients had been introduced by many, particularly the Middlesex, and was promising really well; it had been accepted by the patients and recognized by them as just. Again, the generous decision of the National Deposit Friendly Society to devote one-third of their surplus—over £125,000—towards the payment of the cost of hospital and nursing services to members was a splendid sign to be imitated, he was confident, by all other approved societies.

Earl Winterton said he was interested in the negotiations between the London hospitals and the Council of Approved Societies in London. There was a possibility of getting a very much larger sum than Colonel Mildmay had mentioned, from this Council—approximately between £200,000 and £300,000. That would tide over the immediate difficulties. These negotiations were nearly complete.

Sir Watson Cheyne said he desired information on one or two matters. The first was, What if any alteration was to be made in the medical services? He presumed that something would be done, because they knew that the panel service could be improved and it would lie between improvement and introducing some new service—a form of State Medical Service. Personally, he should favour finding out what the defects of the panel service were, and trying to improve it, rather than scrapping it and introducing a new service, which certainly would not be at all favourable to the medical profession. Various things were required to bring the panel service into a better condition. Much assistance was required to help medical men to diagnose their cases and also in certain other matters. So far as his own experience in consultation had gone, he had not come across any evidence to support the accusations made against panel doctors, but he thought that in a few cases the statements might be more or less justified. When the Insurance Act was first considered, he was very doubtful about the question of medical benefit; he welcomed the idea of insurance against sickness, but questioned the advisability of the panel system. One thing wanted was to increase the free choice of doctors. The advantage of a greater choice of doctors would be to reintroduce competition to a very marked degree. He held that a State medical service was undesirable; one reason against it was patent to everybody, and that was that the State control of industries had not worked satisfactorily. Coming to the question of research, he deplored that the work of the Medical Research Committee had been transferred to the Privy Council. They were told when this was done under the Ministry of Health Bill that a certain amount of research was going on in connexion with the old Local Government Board, and that this might be developed. He understood that at present the Medical Research Council was ready and willing to assist the Ministry of Health. One of the great attractions for scientific men was to have an opportunity for investigation, and it was up to the Ministry of Health to help any of their staff who wished to do research and not to have to go to another body and ask leave. The existence of a proper Research Department was extremely necessary for the future of the Ministry of Health. For if any body required information it was that Ministry, inasmuch as matters connected with life, disease, and death were still in the melting pot, and questions must constantly arise which required investigation. At present there were remarks about research in the Estimates, but apparently not much was being done. The whole expenditure of the Ministry of Health on laboratory work was £700. There was a second heading under which some expenditure came and there were two special inquiries. He was not speaking in criticism

but in the hope of hearing from the Minister that more was to be done in this direction.

Mr. Irving called attention to Circular 185 as in direct antagonism to the speech the Minister of Health had delivered. The circular, he said, was an attempt to save money along pettifoggish lines in child welfare. It complained of expense in administration, and in other services in the distribution of milk.

The Minister's Reply.

Sir Alfred Mond, replying to a number of the questions raised, emphatically denied that Circular 185 was inspired by a niggardly spirit. The Ministry had introduced experimentally a new medical service in providing milk for expectant mothers and infants. The experience, after very careful investigation, had been that in certain areas this service had been grossly misused, and that everybody who had wanted milk for nothing had been getting it. Most sympathetic and competent lady doctors had told him that what had happened in various localities amounted to a gross scandal. All that the circular did was to require strict control of the milk, and to place the distribution under medical supervision. Coming to a complaint by Mr. Stewart, Sir Alfred said it rested with the local authority to make by-laws as to tents, vans, and sheds, and apparently they did not yet know what their powers were. The subject, he admitted, was not altogether free from difficulty as regards rating, and apparently as long as there was no epidemic his powers of intervention were small. Dealing with the speech of Sir Watson Cheyne, the Minister said he could set at rest any fears he had of a great extension of State medical service. There was no intention to start a vast system of State medical service. The Ministry was working on the lines of endeavouring to improve the panel system. The panel had been limited and reduced generally to a maximum of 2,000. An insured person not satisfied with his doctor could now leave him by mutual consent or after six months. They were making improved regulations in regard to surgeries. The panel system, he thought, had not worked so badly, and he believed that the medical profession had a great desire to do their best. He believed that the patients, on the whole, were satisfied with the service they obtained. Seeing that it was a great experiment, and the large number of medical men employed, he did not think very serious fault could be found. In his opinion there was a great deal of weight in the argument of Sir Watson Cheyne as to medical research. The question of voluntary hospitals had been giving him very grave anxiety; he expected the Cave report towards the end of the month. He was extremely sorry that certain of the large hospitals deemed it necessary, notwithstanding the fact that the report of the Cave Committee was so closely impending and that the Government would be bound to take action upon it speedily, to close those large numbers of beds, although in a few weeks the crisis might be passed. The Cabinet could not reasonably be asked to bring forward a scheme within the next few days. On the other hand, the approved societies had already set aside £250,000, to be paid during five years, out of their surplus. He should have thought it would have been possible for the hospitals to get their bankers to advance the comparatively small sums necessary for carrying on during the next few weeks. He wondered whether something could not be done in that direction even now.

Dr. F. E. Fremantle, in urging that the Ministry of Health, in its care for economy, should exercise discretion, referred to the case of a local authority which had made ruthless reductions in its estimate, with grave danger, he thought, to the large working-class population to whom it was responsible. On the other hand, he asked for an explanation of the enormous size of the administrative and clerical staffs of the Ministry, which exposed it to the criticism that there was too much red tape, too much letter writing, and too much filing work. He suggested that there should be a checking committee in each office, composed of members of the existing staff, whose duties it should be to decide the particular returns absolutely necessary. As for the medical staff, he had looked into the extra work which was being done and found that it was extraordinarily large. As for research, the Ministry of Health, in laboratory work, had performed to a great extent what Sir Watson Cheyne had said was not being done. That was the *ad hoc* work in regard to sanitation generally. It was only where the research was of a more general nature that it was done by the Medical Research Department under the Privy Council. He assumed that the Director of the last-named department was in touch with the Ministry of Health; if not, it would be not far short of a scandal to be looked into at once. He reminded the Committee that there were two kinds of research—the *ad hoc* and the research not directed to a special object, but of a general character. It was to get independence of administration that this latter research was placed under the care of the Privy Council. Dr. Fremantle argued from the actual vital statistics of the year that the Ministry of Health was engaged in a winning battle, and expressed the belief that the lessening of mortality was largely due to the improvement of services under the Ministry of Health.

Dr. A. C. Farquharson said he regretted to hear that Sir Alfred Mond proposed further to reduce the medical staff of the Ministry of Health, though this staff was getting collectively a sum rather less than one-third of what was being paid to the mushroom growth in connexion with housing. Instead of an increase in the payment of the medical staff, as had been suggested was the case, there was a diminution of something like £7,356, and the staff was to be reduced in the

near future. He was not concerned as to relative figures of the Local Government Board; he took the problem on its merits. These 80 or 90 medical officers recently appointed were to see that proper services were rendered in connexion with something like 6,000,000 or 7,000,000 insured people. They had to bring themselves into liaison with 12,000 or 13,000 doctors. They had to unite the work of approved societies and professional men. In terms of finance, they had the spending of something like £9,000,000 per annum. Yet a paltry sum of £100,000 was being spent on the whole medical staff of the Ministry of Health, while a sum of £300,000 was being spent on the excremental growth in connexion with the housing scheme. These medical men were very eminent men who had acquired a reputation in their profession before they entered the Ministry, and they would give good service to the State. To propose to cut them down or turn any of them out was the most short-sighted policy of which he could think. As for research, he felt strongly that unless the Ministry of Health had a properly equipped laboratory and properly trained scientists, the functions which was laid upon it by statute in the Ministry of Health Act, must remain dormant. He recalled that it was at his instance that an amendment was made in the Public Health Act which placed the responsibility on the Ministry of Health for the direction and elucidation of research. So far as he could gather from the figures in the estimate, the total sum to be spent by the Ministry on research, including the payment for laboratory attendants, special inquiries into disease and pathological expenses, was £2,444. Compared with the sums that Continental nations had devoted to research, the figure was ludicrous. If this country spent upon disease one hundred times as much as it was spending already, that would not be a penny too much. Yet they had the Ministry of Health, to which they had looked forward with such hope, revealing from the very first its feet of clay. On the other hand, he congratulated the Minister of Health upon the increased expenditure in connexion with maternity and child welfare. Regarding the increase of over half a million sterling in the estimate for the treatment of tuberculosis, Dr. Farquharson said that in his opinion sanatorium treatment had broken down, and he suggested that the Minister of Health should exercise some limit of expenditure on schemes sufficiently tried to be pronounced upon as more or less failures. If there was one person more dangerous than another in respect of these matters it was the platitudinous politician who mixed his politics with sentimental notions regarding sanitary and scientific matters. The most recent scientific work went to show that in this country, at all events, it would be impossible to have a tuberculosis-free population. Dr. Farquharson went on to inquire as to the grant to the National Council for Combating Venereal Diseases. He understood that the amount was about £10,000. He did not doubt that the Society was doing good work, but why should a grant be made to one society and none to the other society which also probably had a good deal of wisdom in its ideas? He raised the question, moreover, whether the Ministry, which had every means of disseminating information, should delegate work of this sort. Finally Dr. Farquharson renewed his appeal to Sir Alfred Mond not to cut down the medical staff.

Mr. Jesson earnestly supported the appointment of the regional medical referees. He read an extract from a letter from a secretary of one of the largest approved societies, complaining of indifference by panel doctors to cases. He did not suggest there were many instances of the kind, but the regional referees would be able to correct them.

Major Birchall regretted any attempt to curtail expenditure upon the Ministry of Health, which he regarded as the "key" ministry of all the other departments.

Dr. J. E. Moison said he regarded the expenditure on regional medical officers as very economical. As for research, he regretted that the department was not under the control of the Ministry of Health, and held that a great deal more money should be spent on this work.

Mr. Godfrey Locker-Lampson criticized the increases in staff salaries, more particularly in the higher secretarial grades, his point being that they went beyond scale increases.

Mr. T. Davies read a telegram from the Secretary of Joint Committees of Approved Societies, warmly supporting the appointment of regional medical officers, because a second opinion was valuable, and because any saving in benefit claims spelled economy. Taking his own experience, however, Mr. Davies added that in the country districts they were liable to miss these attentions. He said that if the Ministry of Health would send once in three weeks to the district of his society a doctor to perform such services, his society would pay £200 for the assistance. It was very difficult for one man to detect an obscure disease. Quite recently he had a case in which the doctor had certified for seven different diseases in seven weeks, and in reply to correspondence had remarked, "It is very difficult to say what is the matter with this particular patient."

Sir A. Mond, replying to various questions, said the salaries of high officials were fixed on recommendations (affecting other departments as well) by an independent Committee over which Mr. Asquith presided. The question of voluntary hospitals and Poor Law infirmaries, and the future of their complicated system, was engaging the very earnest attention of his department. It was extremely difficult. They did not want to destroy the voluntary hospitals and make them State-aided or rate-aided institutions. The voluntary system had been a very remarkable success; but, on the other hand, there was the possibility at a future date of developing Poor Law infirmaries. These were not questions for that moment, but were being considered. The vote was then passed.

Tuberculosis Bill.

In accordance with a pledge given by Sir Alfred Mond to Dr. Raw, a new clause was added in Committee in the House of Lords to the Tuberculosis Bill, in order to meet the cases of seamen. This was brought down from the House of Lords to the Commons on May 12th.

The Treatment of Bilharziasis.—Mr. Doyle asked, on May 12th, whether the Minister for Pensions was aware that Dr. Christopherson's antimony treatment was now accepted as a certain cure for bilharziasis; that the Australian Government, after segregating all returned officers infected in Egypt, had completely stamped it out by this method of treatment; that there are still a number of men in this country who were infected during the South African war, and were still sufferers, but who were debarred from treatment by the Ministry because they had not served (in many cases because of this disease) in the recent war; and if there were any reason why an exception should not be made in favour of these men so that they might receive treatment? Mr. Macpherson sympathized with the suggestion, and said he was communicating with the War Secretary about it.

Arsenobenzol Treatment for Venereal Diseases.—Mr. R. Richardson asked the Minister of Health, on May 12th, if he would give a return of all the cases of death arising from the ill effects of the arsenobenzol treatment of venereal diseases which had been reported to his department since the commencement of the public treatment of these diseases; and if he would arrange for such particulars to be recorded in future in his annual report or in that of the chief medical officer. Sir A. Mond replied that twenty-one deaths had been reported to his department as following the administration of arsenobenzol compounds in treatment centres of venereal diseases. Further inquiries show that in three of these cases death was not due to the administration of the drug, and that in five other cases it was doubtful how far the drug had contributed to the fatal result. In the last complete year for which figures were available, the number of deaths in which the administration of the drug had been a contributing cause represented one in approximately every 4,300 patients treated for syphilis, and one in approximately every 30,000 injections of the drug. He would consider the suggestion in the last part of the question.

"Lock-up" Surgeries.—Mr. Doyle asked, on May 12th, whether the attention of the Minister of Health had been drawn to the increasing number of what were known as lock-up medical practices, where panel medical practitioners saw panel patients at fixed hours only, as they the doctors had only consulting rooms there, while they resided, it might be, miles away, out of reach of a panel patient in an emergency; and whether, in view of the hardship thereby incurred by the patient, he would consider taking action. Sir A. Mond said his attention had been called to one or two cases of the kind, and they were under investigation. If Mr. Doyle was aware of any such case he would be obliged if particulars were furnished. The regulations made adequate provision for dealing with such cases.

Medical Decisions on Eligibility.—Mr. Forest asked, on May 9th, whether the Minister of Pensions was aware of the growing resentment in the country, especially among service men, at what were thought to be the unfair decisions in many of those cases in which a man with a long record of good service and an A1 health certificate on entering died soon after returning to civil life, from, according to medical test in my, so to ailment not connected with his war service, but of which he never showed any previous trace, and whether steps could be taken, even if it meant some modification of the law, to meet such cases. Mr. Parker, for Mr. Macpherson, replied that he was not aware there was any feeling in the country that unfair decisions were being given. All cases were most carefully considered by experienced medical officers, and in every case where the claim was rejected on the ground that the disease was not attributable to, or aggravated by, military service the widow had a right of appeal to a tribunal which was independent of the Ministry.

Chemicals among the Key Industries.—References were made in debate in Committee of Ways and Means in the House of Commons, on May 9th, to the optical instruments and to the chemicals which are to come within the provisions of the Safeguarding of Industries Bill. The subject came up on the money resolutions which are being taken to prepare the way for the introduction of the measure for White Industries. Optical glass and optical elements, microscopes and other optical instruments, thermometers, tubing and other scientific glassware, laboratory porcelain, a variety of scientific instruments and chemicals are included amongst the articles upon which an import duty amounting to 33 per cent. is to be imposed. Sir William Pearce, in supporting the motion as a private member, referred to the report of the Balfour of Burleigh Committee and to the report of the National Health Insurance Commission, with regard to certain fine chemicals not produced in this country before the war.

The Committee on Hospital Finance.—The Committee on Hospital Finance, of which Lord Curzon is chairman, has completed the taking of evidence, and is now engaged on its report. The expectation is that this will be presented to the Minister of Health near the end of the month and published early in June.

Dangerous Drugs Act Regulations.—It is understood that the report of the Dangerous Drugs Act Departmental Committee is practically finished and will be available in a few days.

England and Wales.

LEEDS GENERAL INFIRMARY.

THE last few years have seen many changes at the General Infirmary at Leeds. Occurring, however, as many of them did, during the strenuous years of the great war, they have been left uncommented upon in these columns. There have been important changes in the personnel of the honorary staff; structural alterations and additions, begun before the outbreak of hostilities, have been brought to completion; a new ward pavilion with about one hundred beds has been in use for some two years, and has enabled the work to be kept up to the pre-war standard of numbers, while certain of the other wards are receiving that process of modernizing which the lapse of time has made necessary, for the infirmary was opened in the year 1868; the new theatres and out-patient rooms are now in full occupation; there has been considerable development in the x-ray department, which has been divided into two sub-departments under the care of two distinct officers, one of whom is at the head of the diagnostic section and the other at the head of the therapeutic section; the department for the treatment of venereal diseases is now fully organized, and will shortly have an addition to its staff; and the dental department of the Leeds Public Dispensary, having found the accommodation at that institution inadequate for the requirements of the growing school, has by the courtesy of the board found a temporary and very excellent habitat in the large out-patient hall which was opened in 1894, but which is now referred to as the "old" out-patient room. The nursing staff has been largely increased; a system of preliminary probationership has been instituted, and all candidates for full training at Leeds have now to undergo a three months' preliminary training; lectures are given by the honorary staff and by the university teachers, and a special tutor sister has been engaged for the work of teaching and supervising the work of the candidates at this stage of their training. These and many other matters of importance should be commented upon, not only as being of interest to former students of the Leeds school, the vast majority of whom have such cordial recollections of their clinical Alma Mater, but because the activities of a large teaching hospital must be of interest to the profession at large.

Changes in the Honorary Staff.

Dr. Churton resigned from the full staff in 1919 after nearly forty years' service, and was elected an honorary consulting physician with the right to the use of six beds. This system which prevails at Leeds was begun in the year 1884, when the rule, which of course was not made retrospective, was introduced that twenty years' service on the full staff was to be followed by promotion to the consulting staff. Under a self-denying ordinance the rule came into immediate operation by the resignation at the end of their twenty years' service on the full staff of Dr. Clifford Allbutt—as he then was—Mr. C. G. Wheelhouse and Mr. T. Pridgin Teale. For some years after his resignation Mr. Wheelhouse carried on an active professional career in Leeds, and then retired to Filey where he died a good many years ago. The activities of Sir Clifford Allbutt are known and admired by the whole profession, and many will be interested to learn that Mr. Teale gave an introductory address to the University Medical Society at the opening of one of its recent sessions, and that within the last few months he addressed the Leeds and West Riding Medico-Chirurgical Society on his favourite subject of lithiotomy. The movements following on Dr. Churton's resignation created a vacancy on the assistant staff, and to this position Dr. J. Le Fleming Burrow was elected.

Mr. R. Lawford Knaggs resigned during the year 1919 from the position of honorary surgeon; he had acted on the full staff for eighteen years and was elected an honorary consulting surgeon on the recommendation of the board at a general meeting of the governors of the infirmary, who have the power to make such an appointment if they think fit, though the officer may not have acted on the full staff for the normal term of twenty years. The compliment was well merited in the case of Mr. Knaggs, whose work has always been characterized by unflinching zeal. In passing, it may be mentioned that since leaving Leeds

Mr. Knaggs has completed a very important piece of work for the Leeds school which has occupied a large amount of his time for many years. This has consisted in the complete revision of the catalogue of the bone and joint section of the pathological museum at the medical school—a work which has entailed a careful examination and remounting of most of the specimens in that section. This catalogue is shortly to be printed. The vacancy on the assistant staff brought about by Mr. Knaggs's resignation was filled by the election of Mr. Alfred Richardson to the position of assistant surgeon.

Mr. H. Secker Walker, having served his period of twenty years on the full staff in the ophthalmic department, has also been elected a consulting surgeon. Mr. Walker, to the regret of his many friends, has left Leeds for Wiltshire. Mr. Constable Hayes resigned his position on the honorary staff in 1918 and has left Leeds for Gloucestershire. The vacancies in the ophthalmic and aural departments caused by these resignations have been filled by the appointment of Mr. Harry Lee to the former and of Mr. W. Maxwell Munby to the latter department.

Dr. J. B. Hellier, who was elected obstetric physician in 1899, completed his term of service in 1919 and became honorary consulting obstetric physician, being succeeded by Mr. Carlton Oldfield. The title of this post, "obstetric physician," gives a wrong impression of the character of the work. The holder of the post is, of course, essentially a surgeon, and in future he is to be termed such. Dr. Hellier's connexion with the Leeds school has been a long and honourable one; he was a student of the school; he acted as demonstrator of anatomy; he taught materia medica and founded the museum; he lectured on gynaecology, and for many years was professor of midwifery. His interest in the school and in the welfare of the students has never flagged, and he has been unsparing of time and of effort to promote the best interests of the university and of the infirmary. He is still in full consulting work, and at the special request of the Faculty of Medicine he has consented to continue to act as honorary librarian for the joint library of the medical school and the Medico-Chirurgical Society. He is engaged, it is understood, in writing a history of the Leeds School of Medicine.

To the great regret of his friends, Professor Leyton resigned the professorship of pathology owing to ill health. The position of professor of pathology is essential to qualify anyone to act as pathologist and director of the pathological laboratory at the infirmary, and Mr. Matthew J. Stewart was appointed in succession to these two positions by the Council of the University and the Special Election Committee of the infirmary. Of the developments and future of the pathological department of the infirmary and of the university more may be said hereafter. Mr. Stewart's work as curator of the pathological and clinical laboratory at the infirmary brought him into relation with all the members of the honorary staff, and his election to the important position of professor of pathology was universally welcomed.

In connexion with a prospective and more intimate connexion between the infirmary and the school of dentistry certain temporary changes in the manner of conducting the dental work of the infirmary are being developed. Mr. Hordern, who has been honorary dental surgeon to the infirmary for a good many years, has been promoted to the consulting staff.

Death of Mr. Edward Ward.

This is not the place for any lengthy reference to the death of Mr. Edward Ward. A short obituary notice appeared in the JOURNAL of May 14th. Any reference to the changes in the personnel of the staff would, however, be very imperfect which did not express the deep regret of all who are connected with the university and with the infirmary and their sorrow in the loss of a well-loved colleague.

Statistics of the Infirmary.

In anticipation of the annual meeting of the infirmary, which is usually held in March, but which this year has been postponed till May 25th, the usual statistical tables of the numbers of patients attended to in the various departments during the year 1920 has been issued. The total number of patients treated within the walls of the infirmary as in-patients was 9,480—practically the same

as during 1919. It is of interest to note that during 1913 the number was 9,015. It has been explained above that the number of available beds has not in the meantime been increased by the opening of the new ward pavilion, and these figures may be taken as an indication that the infirmary is working, as it was in 1913, up to the limit of its resources. Of the new patients admitted 3,914 were men, 3,347 were women, and 1,500 were children. Four hundred and twenty-one patients remained in the infirmary and in the semi-convalescent hospitals on January 1st, 1920, and the balance of 298 was made up of service pensioners referred to the infirmary by the Ministry of Pensions. The average number of patients at the infirmary was 363, and at the two semi-convalescent hospitals 113. The number of new out-patients was 20,109, and of casualties 15,969. In addition there were 3,128 new cases in the venereal department. Operations were performed on 5,378 in-patients and on 3,929 out-patients.

WAR MEMORIAL AT THE LIVERPOOL MEDICAL INSTITUTION.

On May 11th, in the presence of a large number of members and ladies specially invited, a war memorial tablet, the gift of Mr. W. Thelwall Thomas, was unveiled by the Right Rev. the Lord Bishop of Liverpool, Dr. Francis Chavasse. The president, Dr. John E. Gemmell, occupied the chair, and briefly set forth the reason for commemorating in bronze those members who had paid the supreme sacrifice in their devotion to duty in the great war. In the name of the Institution he conveyed the thanks of the members to the generous donor. Mr. Thelwall Thomas, in acknowledging their appreciation, mentioned the fact that the number of members of the Institution was under 400, yet on the tablet fourteen names were inscribed who had served their country even unto death. The Lord Bishop delivered a short address before unveiling the memorial. He referred to the painful distinction conferred upon him—his son's name, Captain Noel G. Chavasse, V.C., with bar is recorded—and said: "No body of men gave more of their sons and daughters to fight and work and fall than the doctors of Liverpool. We owe these men a debt of gratitude for the high ideals they set before us, and their names should ever be before us as examples of faithful service and loyalty to their country. To such we owe our deliverance from a tyranny that knew no pity and no shame."

The memorial tablet was executed by a Liverpool sculptor, Mr. Tyson Smith. It is of bronze, with the R.A.M.C. motto, "In Arduis Fidelis," inscribed on the capital. Underneath, "In honoured memory of members of the Liverpool Medical Institution who gave their lives for their country." There are fourteen names, preceded by their respective ranks, and on either side are reversed torches, with the naval and military crests of the medical service. The memorial is chaste in design and was much admired. It occupies a conspicuous position in the vestibule of the institution.

LIVERPOOL ROYAL INFIRMARY.

Mr. Robert Kennon has been appointed an honorary assistant surgeon to the Liverpool Royal Infirmary. He is M.D. of the University of Liverpool and F.R.C.S. For the past twelve years Mr. Kennon has held with distinction posts in connexion with the university. He saw active service during the war, was awarded the M.C., and was twice mentioned in dispatches.

India.

VENEREAL DISEASES: TREATMENT IN INDIA.

THE League for Combating Venereal Diseases, Bombay, has been in existence since March, 1917, and its work in that city is, we believe, a pioneer effort in the direction of combating venereal disease among the civil population of India. According to the third annual report of the League (1920-21) the incidence of venereal diseases in India is much higher than in England. As the provision of greater facilities for the modern treatment of venereal diseases was considered the first essential in the campaign of the

League, attention so far has been specially devoted to the dispensary which was founded, and is being conducted, under its control. From the report of the dispensary's medical officer it is evident that the work that is being done there is of a high standard, but as no more than 1,224 patients were registered during the year under report of whom 217 were diagnosed non-venereal, only the fringe of the problem can yet have been touched in a city of the size of Bombay. The medical officer points out that the dispensary building is greatly lacking in privacy, and suggests that a general dispensary might be attached in order to induce patients to attend without having the nature of their ailment made so obvious; this recommendation is worthy of attention if a more suitable building cannot be secured. He emphasizes also the necessity for the provision in Bombay of facilities for the ante-natal and post-natal treatment of pregnant married women who have been infected by their husbands. Subsidiary centres for early treatment are also recommended in his report; irrigation stations have already been established for the daily lavage of gonorrhoeal cases from the dispensary at a few municipal dispensaries in crowded parts of the city. Here again, however, the number of patients treated—84 in seven months—seems out of proportion to the work entailed. There is little doubt, therefore, that the stage of the League's campaign which is to come next—a vigorous educational propaganda—is very necessary if the population of Bombay is to benefit from the provisions which have already been made. It is intended to arrange a series of lectures in English and the vernaculars at different centres, and to distribute leaflets. A dissemination of the knowledge of the physiological laws of life, particularly among the lower classes of the population, should open their eyes to the seriousness and the grave consequences of venereal diseases. This propaganda should also create and develop a public opinion in favour of the League among all classes of society, and it is to be hoped that it may obtain the general support which it deserves, and that the campaign which it is conducting will spread throughout India.

CIVIL ASSISTANT SURGEONS.

A new scale of pay for civil assistant surgeons has been announced by the Ministry of Local Self-Government, subject to the limit sanctioned by the Secretary of State. The revised scale provides for pay of Rs.200 a month on first appointment, with biennial increase of Rs.25 till the eighteenth year of service. There will be grade examinations at the seventh and fourteenth years, and, at a later period, an efficiency bar is prescribed. There will be two senior grades, to which promotion will be by selection; these grades will contain four posts of Rs.425, and four posts of Rs.450. Civil assistant surgeons appointed to civil surgeoncies will draw Rs.500 by annual increments of Rs.50, and annual increments of Rs.100 for those with over five years' service to Rs.700. There will be one selection post of Rs.1,000, which will be open to officers of the Indian Medical Department and civil assistant surgeons. The new scale is to have effect from April 1st, 1920.

Correspondence.

HEART-BLOCK AND THE ADAMS-STOKES SYNDROME.

SIR,—At the Liverpool Medical Institution (*BRITISH MEDICAL JOURNAL*, May 14th, p. 704) Dr. Harris expressed the opinion that in heart-block the Adams-Stokes syndrome signified degeneration of the heart muscle. It is very difficult to understand why this syndrome appears in some cases of heart block, but not in the majority. Yet I fear Dr. Harris's explanation may fail us. Two or three times I have had reason to believe that this explanation could not be accepted as a general rule. One case in particular seemed to be to the contrary.

An elderly gentleman in whom for some years a harsh systolic murmur had been audible at the base of the heart, began to suffer from bradycardia. A little later, when his pulse rate had fallen to 30-20 the Adams-Stokes syndrome appeared. The malady increased slowly but inexorably. I often counted his ventricular pulsations as low as 12 or 10,

or even less. His own physician, the late Mr. Hyde Hills, more than once counted it at the rate of 6! The Adams-Stokes syndrome was intense, and the syncopic and convulsive series were frequently repeated—often more than once in the day.

After death an aortic stenosis, evidently of very long standing, was discovered. The fibrous condensation, beginning no doubt at the aortic collar, gradually invaded the *a-v* structures. Now the heart, in obedience to the increased obstruction, had hypertrophied, and become very large and powerful. Macroscopically it appeared sound and firm; and microscopically, beyond a slight degree of fibrosis, it presented little or no default.—I am, etc.,

Cambridge, May 14th.

CLIFFORD ALBUTT.

ECLIPSE BLINDNESS.

SIR,—I read with interest the article on eclipse blindness by Dr. Lodge, in the *BRITISH MEDICAL JOURNAL* for May 14th, and having, like I suppose most ophthalmologists, seen two similar cases following the recent eclipse, I would like to make a few comments, mainly supporting Dr. Lodge's arguments.

The first case that I saw was a girl of 18, who was led into my consulting room by the hand as though she were blind, three days after the eclipse; her history was that within a few minutes of looking at the eclipse through moderately black tinted spectacles, she had great pain in the eyes, and then "everything looked blank" when she looked at it. I found the central vision in each eye to be considerably less than 6/60, due to a large central scotoma for both white and colours; it seemed quite evident that peripheral vision was relatively unaffected, though vision was so defective that it was impossible to obtain any chart of her visual field on the perimeter. Both pupils reacted normally to light, and on dilatation with homatropine a careful examination of the fundus revealed no definite pathological appearances, beyond possibly a slight injection of both discs; a subsequent examination twelve days later still revealed no pathological changes in any part of the fundus.

This case is evidently very much more severe than either of those quoted by Dr. Lodge, and one is very uncertain as to the prognosis—subjective symptoms in her case were severe, particularly pain at the back of the eyes and through the temples, which lasted for about a fortnight and had to be relieved by opiates; there was also, for the first few days, a good deal of photophobia, though no trace of redness of the anterior parts of the eyes. Dr. Lodge suggests the possibility of confusing retrobulbar neuritis with this condition, but in this girl there was nothing to suggest it, the pupil reactions being perfectly normal and contraction well maintained when a light was kept focussed upon them; moreover, the girl appeared to be in perfect health. The actual change which takes place at the fovea is a matter of conjecture, and it is instructive to see that vision can be so profoundly affected as in this case, without there being any alteration in the retina that can be detected with the ophthalmoscope. If microscopical examination of the retina in a case of this sort could be obtained, it would no doubt throw light on the condition, but, so far as I can discover, this has never been done, owing no doubt to the difficulty in obtaining such an eye for examination.

Many ophthalmic surgeons after previous eclipses have described changes in the fundus consisting of a small yellow speck surrounded by an abnormally red appearance at the fovea in such cases—an appearance which it must be difficult to differentiate from that of a physiologically normal fundus. The two cases recently seen by myself support Dr. Lodge's contention, that there are no changes visible to the naked eye in the majority of such cases.

The symptom that Dr. Lodge describes as metamorphopsia was not present in this girl, as her vision was affected too severely for her to be able to appreciate it had it been present.

In view of these cases it certainly seems advisable, as Dr. Lodge suggests, that in future, before an eclipse, the public should be adequately warned, through the medium of the press, or in some other way, of the danger of looking at the eclipse without proper protection, tinted glasses being entirely insufficient to give such protection. If the injury to sight in such cases as the one to which I have referred is permanent it is a disaster which could and ought to be prevented in future.—I am, etc.,

Norwich, May 16th.

G. MANTON.

THE PREPARATION OF SCIENTIFIC PAPERS.

SIR,—In his letter printed in your issue of May 14th Sir James Barr is good enough to offer a series of "rules" for the guidance of writers engaged in the construction of scientific papers and in the preparation of such papers for publication. These "rules" may be accepted, I suppose, as the fruit of Sir James's considerable personal experience—in part as a contributor to medical journalism, in part as a critic, not to say a censor, of the literary efforts of others. They therefore come with a certain presumption in their favour, and the gratuitous quality of the offer adds grace to the occasion. But why is Sir James so angry with other authorities, and these not deficient in experience, who adopted at an earlier date the course he now pursues? The Medical Research Council and the *BRITISH MEDICAL JOURNAL* have each made a contribution to the end which Sir James himself is anxious to serve, and surely both the one and the other, on such a topic, have an abundant title to speak. Yet for their efforts Sir James has no larger measure of courtesy than the borrowed exclamation, "Sack the lot!" If such is the appropriate fate for advisers with whom Sir James Barr does not happen to agree, is there not some risk that he himself may fall into a similar catastrophe? The iconoclastic temper is apt to prove infectious, and, strange as it may seem to Sir James, not everyone will accept him as an instructor, even on the generous terms he proposes, for while in some respects his advice may be generally allowed, his performances do not invariably rise to the level of his precepts.

Sir James Barr not only provides "rules" for the literary aspirant, but in his criticisms of your leading article (April 23rd) he concerns himself with various questions of literary style, or at least of literary expression, and his comments may reasonably be examined in reference to his voluntary appearance as a director and guide. With his ban upon "superfluous" words, readers in general and editors in particular will doubtless be in complete accord. But is Sir James very fortunate in the example he selects? He condemns as "superfluous" the "it" in the sentence, "his [Gibbon's] notes . . . usually contained matter which he judged it becoming to veil in the decent obscurity of a dead language." Yet in an earlier paragraph he himself writes: "Why the Medical Research Council should have found it necessary to issue such instructions I cannot say." If the one "it" is superfluous, why not the other? A few lines from the judgement above recorded Sir James complains of your contributor that he writes "as if he had not got an independent opinion of his own." Critics may possibly differ as to the elegance of this phrase, but on the most liberal construction is not "got" superfluous? And would anything be lost if the words had run "as if he had not an opinion of his own"? In his specific instructions to intending authors Sir James tells us to fasten our papers with "an ordinary paper fastener," and in view of his fashion of searching criticism I feel bound to ask, is not "ordinary" superfluous? On the point here in issue Sir James gives us excellent advice, but he scarcely lives up to the height of his exhortation.

Another instruction Sir James Barr offers to the author and writer is "learn when and where to place capital letters." The advice is hortatory rather than helpful, and illustrative guidance is hardly to be found in Sir James himself, for in his letter he writes "the Tower of Siloam," whereas both in the Authorized Version and in the Revised Version the phrase is "the tower in Siloam." Here Sir James is as unhappy with the preposition as he is with the capital letter, and this is the more remarkable seeing that for accuracy in this respect he urges a high demand. He will not suffer your contributor's phrase "a drawing should be made *in* Indian ink," and he insists upon the correction "*with* Indian ink." I wonder whether he would allow such a description as "a worker in brass and iron" or "a painter in water colours."

Really Sir James Barr would be more effective if he always practised the precision and accuracy to which he invites us. He directs, for example, that when numerous corrections have been made in a typewritten article the "revised version" should be "again typed." Would not a critic, following Sir James's severity, be justified in remarking that as the "revised version" has not yet been typed it is impossible at the present stage that it can be "typed again"? Finally, to complete the series, while

other guides to literary excellence warn us against the "split infinitive," Sir James gaily writes "she wished to strongly express." He thus compels the doubt whether we can afford to accept him, to the exclusion of others, as a master and exemplar in the craft of authorship. He proclaims a lofty standard and for this we owe him thanks. But his censures are not always supported by his performances.

To the classical advice, "Verify your references," Sir James naturally gives unqualified support. He tells us, indeed, that a certain discovery "necessitated me verifying the references," though, fortunately, he does not ask us to parse this phrase. Here again, however, devotion to an ideal is found to be not inconsistent with some laxity in practice. Your contributor (April 23rd) has a sentence, "he [the compositor] ought not to be put to the test." Sir James makes this read, "he ought not to be put to *that* test," and on this misquotation and "in the name of common sense" he founds an indignant protest. So true is it that even Homer sometimes nods, and that a profession of "common sense" may at times be associated with something that looks amazingly like common carelessness.

Sir James's advice to editors—a third feature of his letter—hardly concerns me, as my own editorial career, always obscure, was closed some years ago. Yet from some of his remarks I fear Sir James has found certain editorial departments not up to his standard. Happily there is one bright spot. It is provided by an American paper "to which I occasionally contribute." This paper boasts an "intellectual" editor, who, by an interesting coincidence, never "mutilates" Sir James's contributions. The inference for those who covet the complimentary adjective is an obvious one. The model editor, we are told, "should allow his ideas . . . to flow freely." Is it not an equal editorial virtue to allow Sir James's ideas to flow freely?

Those of us who aspire to be pupils rather than professors may, doubtless with advantage in some respects, take note of Sir James Barr's advice, even though, while pointing to brighter worlds, Sir James does not himself always lead the way. But we are little likely to join in a cry for the "scrapping" of editors, researchers, councils and journals in order to put Sir James Barr on the throne. These threatened authorities may remember with encouragement that Charles II lived without fear of a assassination because, as he explained to his brother, "They will never kill me James to make *you* king." We had better suffer the whips of Solomon than invite the scorpions of Rehoboam. And if, in turn, the occasional contributor may venture a modest word of counsel to those who are so anxious for his improvement, it would be to remind each of these benevolent instructors of the importance of steadily supporting precept by example, "lest that by any means, when I have preached to others, I myself should be a castaway."—I am, etc.,

London, W., May 16th.

C. O. HAWTHORNE.

THE PREVENTION OF PUERPERAL INFECTION.

SIR,—In your leading article based upon Dr. Blair Bell's able paper in your issue for May 14th a matter of enormous importance to the general practitioner is raised. You lay down a standard of asepsis in midwifery which many will regard as quite impracticable. You state that in a case of normal labour no vaginal examination should be made unless absolutely unavoidable, and that in all cases the patient and the attendants should be prepared as for a major operation.

I do not say that anyone will deny this as an ideal, but I think every conservative-minded practitioner will regard it as an impossible one, and I believe a frank discussion of how far this is so to be a matter of great practical moment.

Personally I am a general practitioner who does a certain amount of midwifery, and also a fair amount of major surgery. I am quite convinced that the amount of skill and experience required in any difficult obstetric operation is fully as great, and the issue, since two lives are involved, is greater than in a large number of major surgical operations—for example, the operation for acute appendicitis. Yet I am forced (and so is everyone else under the same conditions) to perform the first operation under thoroughly bad conditions, and for absurd fees, while there is no difficulty in getting ideal conditions for the poorest person in the second operation, and where fees are involved they are adequate.

What is the chief reason for this state of affairs? It is the fact that custom and usage in connexion with obstetric operations dates back far beyond the first dawn of asepsis and far beyond the present status and organization of the profession, while that connected with major surgery has been recent and followed both. The old tradition of general practice that midwifery was the basis of it, and as a matter of business must be secured at nominal and wholly artificial fees, is the main trouble. Tradition dies hard, but the fact remains that the advent of the midwife is fast rendering this belief a mere tradition, and with the midwives lies, Sir, in my opinion, the only hope of realizing your ideal.

It is not the slightest use expecting the busy doctor to act as a good midwife. If he is doing the midwife's work he must make frequent vaginal examinations, and he certainly will put on forceps much too often to do all the other things that Dr. Blair Bell deprecates. Patients who want a doctor to act the part of a good midwife must be prepared to pay such fees as are quite out of the question for the vast majority. It is, and should be, a luxury for the rich. The first of your propositions—absence of vaginal examinations—can only be obtained by the presence of a patient and skilled person with the woman for many hours. This person is naturally the midwife. Your second proposition, that any interference with the confinement must be treated as a major operation, is much more difficult of attainment, but it is psychologically impossible to the doctor who tries to act as his own midwife. It involves education of the public and of public bodies to regard it as a major operation. Only when they put it in the same category as appendicectomy will it be possible to do it under the same conditions.

Let me conclude by tabulating my ideas of how the change can be brought about.

1. We must encourage midwives in every possible way, and we must try to raise their educational standard and their fees. Every case should be attended by a midwife, with a doctor in the background to come in if an operation is to be performed.

2. We must try and get this idea that interference is an operation more and more into our own heads and that of the public and of public bodies—that it is an operation, and that it must be paid for as an operation.

3. There is no reason whatever why every general practitioner should practise obstetrics any more than he does major surgery. What would the standard of surgical work be like if every family doctor, whether his tastes lay that way or not, were compelled by the force of public opinion to operate on his patients for all surgical emergencies? It would be far better if obstetric work were undertaken only by those who really liked it and were interested in it, working in conjunction with the midwives, and having at their disposal adequate lying-in wards at every hospital. There is only one necessity to secure this, and that is money. No small group of practitioners is going to undertake the extremely arduous task of doing practically all the serious obstetric work of a town unless it is made to pay them at least as well as it pays the small group who at present undertake the major surgery, but under these conditions I am convinced the men would be forthcoming, and the other men of the town would be only too glad to be relieved of the necessity of undertaking the midwifery to keep the family in the practice.

I fear that any real advance in this direction will remain an ideal so long as such fees are accepted as I notice in the same issue of the *JOURNAL* as proposed by the Scottish Board of Health. The comparison between that table of fees and Dr. Blair Bell's article is most instructive. The rule that you cannot get good work without paying for it is not to be set aside by any amount of preaching of the ideal. We must raise the whole status of the obstetric operation.—I am, etc.,

Dover, May 16th.

A. R. JORDAN, M.D., F.R.C.S.

SIR,—Again the heavy guns have opened on the general practitioner and the midwife, and we are told for the *n*th time that we are responsible by our negligence for the unsatisfactory results disclosed by the Registrar-General's report on maternal mortality. But our withers are unwrung, and again the result will be a tolerant smile on many of our faces, and some facetious remarks about those who have opened the bombardment. And it always

will be so until those in high places mend their ways and supply opinions gained from tested observations in place of some of the *a priori* generalizations that are usually thrown out.

It is a pity that there has grown up two techniques of midwifery—one that taught in the schools, and the other that practised on the major part of the population. But to think that the latter is due to mere carelessness is a mistake. The practitioners feel that in default of better instruction they must rely on their own observation and evolve their own technique.

The general practitioner still retains some remnants of his scientific training, and likes evidence in support of *obiter dicta*. So as one of them I should like to ask whether there is good evidence that—

1. Labours conducted as major operations are less liable to sepsis than those conducted with ordinary cleanliness?
2. Easy labours without vaginal examination are much less liable to sepsis?
3. Puerperal infection is really less prevalent in the homes of the well-to-do who are attended under so-called ideal conditions?
4. Puerperal infection is more common after such operations as simple forceps delivery or manual removal of a retained placenta than in labours ended by nature alone?
5. Infective organisms are almost always conveyed into the vagina and uterus by the attendant's hands and instruments?

Also I should like to ask:

6. Will a staphylococcus go up into the uterus on the surface of a rubber glove as easily as on a washed finger?
7. What is the exact mechanism by which a sterilized overall or a face mask prevents infection of a patient's uterus?
8. Does examination of organisms found in cases of puerperal sepsis supply any conclusive evidence of their origin, whether from the perineal skin, the skin of the attendant, materials used at the time, or from such external sources as pyorrhoea or otitis in patient or attendants?

In most cases I think the general practitioner would say that as far as his experience goes the answer to questions 1 to 5 is in the negative, but he is open to receive evidence, but not *a priori* assumptions, to the contrary.

Frankly he is puzzled by the fact that he knows he is far more aseptic than he was thirty years ago, but the figures of sepsis remain practically unchanged, and he is inclined to think that the fault may be that of his teachers, who may be chasing a will-of-the-wisp with their cry of still more asepsis, when possibly what is really required is more intelligent efforts to find out the real mechanism of infection and a new technique to meet it.

And so the big guns will boom to no effect until they show that they base their dicta on carefully verified observations, and show more respect for exact reasoning than they seem inclined to do.—I am, etc.,

Cambridge, May 15th.

C. M. STEVENSON.

SIR,—Are the methods recommended in your issue of May 14th at all practicable in dispensary and working-class practices, which must furnish a very large percentage of confinements throughout the country?

I have been in general practice two years, and, though I started with ideals quite in line with the recommendations, I find myself gradually adopting quite a different course of procedure owing to force of circumstances.

1. With reference to the application of forceps, I used to be terrified at the idea of putting on forceps to save time; now I am all in favour of getting the case over as quickly as possible owing to the pressure of other work coming along. When there is delay in the second stage caused by partial inertia, I ask myself the question: "Are you satisfied that you can deliver the woman with forceps if the injection of 1 c.cm. of pituitrin does not finish the labour in fifteen minutes?" And if I am satisfied that I can, then I give it, with so far the happiest results both for the anaesthetized patient and myself.

2. With regard to asepsis, I was amazed to find how many women were practising as maternity nurses who never used antiseptics during or after the confinement, nor

did they provide themselves with such a luxury as an enema syringe. All talk of aseptic midwifery is beside the mark so long as such persons are allowed to compete with the regular midwife.

Any attempt to instil better ideas into this class of nurse only results in your cases diminishing in number in the area where they work, and the nurse is usually engaged first and the doctor afterwards.

I am writing from the working-class end of a good London suburb, so such conditions cannot be exceptional. I do not think that there is likely to be any change in the conduct of midwifery practice and the results as regards puerperal infection till general practitioners frankly state how they conduct their maternity practice, and then, if possible, better methods of action could be decided on, having due regard to the actual difficulties of the situation.

Such an inquiry could surely be made by the British Medical Association through its Branches, and results obtained which would have a real effect on the incidence of puerperal sepsis.—I am, etc.,

May 15th.

C. M. A.

PREVENTION OF VENEREAL DISEASE.

SIR,—Lord Gorell states in his letter, which you printed in your issue of May 7th, that there is now admitted to be but one point of difference between the two societies. In order that your readers may appreciate the extent of the difference it is necessary for them to read our letter to Lord Gorell of April 22nd, which was not published in full in the *BRITISH MEDICAL JOURNAL*. We adhere to the position defined in that letter, and are still ready to meet the National Council for Combating Venereal Diseases according to our letter to the Bishop of Birmingham of February 25th, accepting his invitation to a round table conference, on the understanding that the National Council for Combating Venereal Diseases were prepared to take action forthwith on the terms of the report of the Bishop's committee.

The National Council for Combating Venereal Diseases did not accept this invitation, therefore the conference did not take place.—We are, etc.,

WILLOUGHBY DE BROKE,
President of the Society for the Prevention of
Venereal Disease.

H. BRYAN DONKIN,
Vice-Chairman, Executive Committee, S.P.V.D.

H. WANSEY BAYLY,
Honorary Secretary, S.P.V.D.

London, W., May 15th.

Dear Lord Gorell,

I am desired by the Executive Committee of the Society for the Prevention of Venereal Disease to thank you for your letter of March 22nd, enclosing a definition of the policy of the National Council for Combating Venereal Diseases, which you tell me had been accepted by Dr. Addison.

We do not know whether Sir Alfred Mond will accept your policy as stated in the "eight points" that you sent to us, but I am afraid it is not acceptable to this Society. It appears to us to amount to nothing more than a restatement of a policy which has admittedly failed to arrest the spread of venereal infection. Indeed you admit this failure in your first point, in which you state that "the nation and the world is, in venereal disease, confronted with a terrible menace to its welfare."

I am sure you will agree with us that venereal disease is not only a formidable menace to national health, but is also a most damaging form of waste, both in men and money. We therefore submit with great respect that it is a matter of grave public concern that the National Council for Combating Venereal Diseases has still no policy to offer except a continuance of a method that has been accompanied by an alarming incidence of venereal disease at a heavy cost to the nation.

It was surely not unreasonable to expect that, after the Bishop of Birmingham's committee had endorsed the practice of immediate self-disinfection, the National Council for Combating Venereal Diseases would at least show some relaxation in their hostility to the policy of the Society for the Prevention of Venereal Disease.

Such recognition as the National Council for Combating Venereal Diseases gives to the value of immediate self-disinfection, although the term is definitely avoided in your definition, appears to us to be inconsistent. You would seem to recommend that personal cleansing immediately after incurring the risk of infection is an essential point of instruction in sex hygiene; and you advocate the public removal of any disability or misapprehension that may now exist with regard to the sale by chemists of disinfectants. But the practical value of this recognition is rendered nugatory by your statement that no instruction in the use of disinfectants should be officially issued, and that disinfectants in connexion with venereal diseases should not be recommended to the public.

We submit that the policy of immediate self-disinfection is either right or wrong. If it is wrong, every conceivable influence should be brought to bear against it, and it should not be countenanced in any shape or form, even to the extent of the use of soap and water. If it is right, it is a weapon which the State is bound to use in the prevention of venereal disease, and the Ministry of Health should take in hand forthwith the necessary and simple instruction in the correct use of disinfectants by those who persist in running the risk of infection. Some knowledge of immediate self-disinfection is already public property.

We had hoped that you would admit the necessity of official instruction in this matter. We might then have joined forces for the purpose of considering the best method by which this instruction should be given. Union, therefore, is impossible unless your society definitely endorses the principle of immediate self-disinfection.

We yield to no one in our support of the moral crusade. But the moral crusade taken by itself is demonstrably inefficient. We deeply regret that the National Council for Combating Venereal Diseases has little or nothing to recommend except a vast expenditure of money for moral propaganda and an attempt to cure established disease that might have been prevented. Meanwhile venereal infection is proceeding at an alarming rate, and the policy of immediate self-disinfection involves neither delay nor money.

We propose to send this letter to the Press, together with your letter of 22nd March.

I am,
Yours very truly,
(Sgd.) WILLOUGHBY DE BROKE.

April 22nd, 1921.

REFRACTION WORK AMONG SCHOOL CHILDREN.

SIR,—Not long ago I was an applicant for a post as school medical officer and I was asked how many refraction cases I could do in an hour. Having always used both the objective as well as the subjective tests and knowing the difficulty with school children, I replied that three cases was a good average. I was at once told that at least six was expected, and I have been puzzled ever since to learn how this number could be done properly. Now I know. Mr. Bishop Harman, in his article, "The axis of astigmatism" (May 7th, p. 656), has let the secret out of the bag. They only use the objective method, they do the retinoscopy and prescribe what they consider to be appropriate spectacles from this alone. I could do six or more cases an hour by this method, but the results would be nothing comparable to those obtained from the use of subjective tests, also testing the vision by means of Snellen's types.

I was in hopes that some ophthalmic surgeon would have taken up the challenge that only objective tests are necessary in school children; but I suppose it is a delicate matter to differ from a colleague who writes in the *BRITISH MEDICAL JOURNAL* as an authority on the subject. But I appeal on behalf of school medical officers in general that we should be protected against statements of this kind, and that we should be allowed to do our work in the way we are taught at Moorfields and other eye hospitals, and give the preference always to the subjective test, using the retinoscopy only as a guide.

The use of the retinoscopy as the sole test is compulsory in infants and young children, but if it is not combined with subjective tests in older children in school clinics there will be still more cases than at present of these children coming to the hospitals to get their glasses changed.

With everything else in the article I am sure we all agree, and thank Mr. Bishop Harman for his lucidity.—I am, etc.,

ARTHUR E. LARKING, M.D., D.P.H.,
Assistant Local School Medical Officer for Bucks.
May 16th.

THE EARLY DIAGNOSIS OF ACUTE ABDOMINAL AFFECTIONS.

SIR,—I hope Mr. McAdam Eccles will not think me hypercritical if I suggest that, in his comprehensive paper on the acute abdominal affections, he has done scant justice to a classical sign when, in speaking of "perforations," he says: "Better to explore than to wait for advanced signs, such as loss of liver dullness."

No doubt the surgeon pays little heed to this sign, and no abdomen is ever opened because of its presence alone, or left unopened because of its absence. But I do trust no one, for many a day, has ever waited for its development. It appeals more to the physician who desires to make the diagnosis absolute before calling in the surgeon;

and, of all the signs in medicine, I can think of none that conveys such certainty, almost such completion, of diagnosis, if it can be safely affirmed to be present, and the deduction of free gas or air in the peritoneal cavity be justifiable. It is not the loss of liver dullness that is valuable, for that is present in many other conditions, but the deduction that this loss of dullness is due to free gas within the peritoneal cavity. In making this deduction there are a number of absolute conditions to be observed. Chiefly, these are the time of its occurrence, the associated signs, and the associated general contour—size of abdomen, shape of chest, and obesity, or otherwise, of the patient. It is an early sign, and only of value when early—within the first few hours. To speak of it as a late sign is to miss its application and cultivate a dangerous fallacy. Once the abdomen has relaxed, or the least distension appeared, the sign is valueless and misleading. It may, and does, appear almost immediately after some perforations, or very shortly after; it can be noticed to have appeared between a first visit and a second visit paid a few hours later. It is essential that the abdomen be obviously rigid and retracted and more or less motionless. Its value lies solely in its association with these signs. Nor must it be trusted to in very obese people, nor in those with deep barrel-shaped chests or emphysema of the lungs. Such people may have no appreciable liver dullness at any time. But in well-shaped adolescents, thin people, or those with abdomens of natural healthy shape and size—and perforation very frequently occurs in such—its detection is easy, and if correct, and the conditions otherwise present which make deduction logical, is pathognomonic of perforation of an air-containing viscus.

Of course, it counts for nothing against perforation if the dullness of the liver is normally present. It all depends upon whether air escapes, how much and where it lodges. Usually, when the sign has been present, the practitioner may await the operation with perfect confidence. As soon as the surgeon opens the peritoneum gas audibly escapes. But in trusting to it, there must be no tympanites whatever, and there is not, in the early stages of any perforation I have ever seen. The sign may be neglected entirely; perhaps it is safer to do so in many cases. Still, it is a classical sign, and its proper significance may as well be justly stated.

I see it is twenty-five years since I first was interested in this subject, and then, as now, no little confusion surrounded its proper importance.—I am, etc.,

Glasgow, May 9th.

R. O. ADAMSON, M.D.

THE SITE OF OPERATION FOR EMPYEMA.

SIR,—I have followed with interest the discussion in your columns on "the site of operation for empyema." As during the war I was wounded in the chest, and subsequently operated on for empyema, my personal experience may be of some little value. The site chosen was in the scapular line, and I can vouch for the discomfort and even actual pain caused by the pressure of the tube when lying back in bed. I usually tried to lie on the sound side, and I know many medical men encourage this, as it is believed to cause expansion of the damaged lung. Be that as it may, it caused me considerable breathlessness and cough. Pocketing occurred three times, and it was over three months before the drainage tube was finally dispensed with.

Since return to civil life I have operated on a number of cases of empyema, and, bearing my own personal experience in mind, have always made the incision anterior to the posterior axillary line. The patients were comfortable and able to lie at ease. I have seen no pocketing and the lung appeared to expand well.

As Mr. Peas in says the particular point chosen does not matter from the point of view of drainage, may my own personal experience be counted as argument in favour of drainage anterior to the posterior axillary line? I have, of course, not forgotten that there are such things as local encysted empyemata. I am, etc.,

May 16th.

F.R.C.S.I.

DIFFERENTIAL STAINING OF CARCINOMATA.

SIR, Dr. Shera accuses me of haste and inexperience. I am sorry, as it does not seem to me to serve any useful purpose in controversy. In common with many laboratory workers, I have used a method indistinguishable from his

for considerably longer than his period of two years. *Pace* Dr. Shera, I was teaching histology before he was qualified, and am still in active practice as a pathologist, and I am quite content to leave the verdict to others of similar experience.

My real point, however, was not controversial, but to suggest that others without Dr. Shera's experience might be led to rely on a "differential" staining reaction rather than on the morphology of the cell itself.—I am, etc..

London, W.C., May 13th.

A. KNYVETT GORDON, M.B.

Obituary.

SIR ROBERT WILLIAM JACKSON, C.B.,
Deputy Surgeon-General.

SIR ROBERT WILLIAM JACKSON, C.B., died at Sandymount, Dublin, on May 13th, aged 93. He was born at Edenderry, King's County, on August 11th, 1827, and was educated in Dublin. He took the L.R.C.S.I. in 1851, the L.K.Q.C.P. in 1859 and the F.R.C.S.I. in 1862. Entering the army as assistant-surgeon in the 90th Foot (Scottish Rifles) on May 26th, 1854, he attained the rank of brigade-surgeon on May 5th, 1881, and retired with a step of honorary rank on December 16th, 1882. During the regimental times he also served in the 84th Foot (York and Lancaster), 86th Foot (Royal Irish Rifles), 100th Foot (Leinster Regiment, Royal Canadians), and for several spells on the staff, and from January, 1862, to January, 1863, was on half pay.

He had a very long record of war service, first, in the Crimea (1854-55), where he was present at the siege and fall of Sevastopol and received the medal with clasp and the Turkish medal. In the Indian Mutiny (1857-1858) he was at the first relief of Lucknow, at the battle of Cawnpur, the defence of the Alambagh, the final assault and capture of Lucknow, the capture of Kalpi and the operations in Oudh; he received the medal with three clasps. He served also in the Ashanti war (1873-74), being present at the action of Essaman and relief of Abakrampra, the battles of Amoafu and Ordalsu, and the capture of Coomassie. He was mentioned in dispatches, and was awarded the medal with clasp and the C.B. In South Africa, in 1879, he was present at the operations against Sekukuni, and was again mentioned in dispatches. He was in Egypt in 1882, shared in the battle of Tel-el-Kebir, was mentioned in dispatches, and received the medal with clasp, the Khedive's bronze star, Medjidie third class and knighthood.

After his retirement he settled at Sandymount, near Dublin, where for many years he took great interest in local affairs. In 1860 he married the daughter of Mr. John Jones Simpson, who died in 1888. He married again, in 1891, the daughter of Mr. Robert P. Daye. He had one daughter and three sons, one of whom is Major R. W. H. Jackson, R.A.M.C. (retired).

THE LATE DR. C. A. GREAVES.—Dr. W. F. Dearden writes: By the passing of Dr. C. A. Greaves of Derby (of whom an obituary notice appeared in the *JOURNAL* of May 7th) the ranks of certifying factory surgeons have lost a truly great personality. His is an excellent example of how well part-time departmental service can be carried out without neglect of other professional obligations. He was a factory surgeon during the long period of fifty-two years—a unique record in itself—and it is well known among his colleagues how conscientiously and thoroughly he fulfilled the duties of his office. He was very exact and painstaking, and during the whole of this period kept a careful account of his work in factories. This regard for note-taking proved to be the salvation of the medical branch of the factory service when, in 1891, the Government sought to abolish the examinations for certificates of fitness, on the ground that certifying surgeons rarely, if ever, rejected anyone for medical reasons. Dr. Greaves was able to produce particulars of over 2,000 rejections on purely medical grounds, occurring during his twenty-three years' service, and the obnoxious clause in the bill did not survive the Committee stage. It is for this particular reason that his name will always be revered by those of his contemporaries who remember this signal service. It was not, however, his only good

work on behalf of certifying surgeons. He was a firm believer in the advantages accruing to both employers and workpeople by the exercise of medical supervision over the youthful worker, and his views were well expressed in an address contributed to the Section of Industrial Hygiene at the Manchester meeting of the British Medical Association in 1902. In the course of his remarks Dr. Greaves clearly laid down the objects to be arrived at by the surgeon in making his examination, and his classification is quoted at length in the official memorandum issued by the Home Office for the guidance of certifying surgeons. He utilized the same occasion to make some very caustic criticisms of the sixpenny fee paid for these examinations, and was very definite in his opinion that "to accept three-quarters of a chimney sweep's minimum as a proper equivalent for the performance of a medical function is surely most degrading." His method of avoiding the degradation was the establishment of a collecting-box into which the "metallic affront" was dropped for the benefit of the Children's Hospital. He resigned his appointment only twelve months ago.

COLONEL ISAAC HOYSTED, one of the rapidly dwindling list of Mutiny veterans, died suddenly at Sidenp, Kent, on May 3rd, aged 88. He was the son of the late John Hoysted, of Walterstone, county Kildare; he was educated in Dublin and at King's College, London, and took the L.R.C.S.I. in 1855; he became L.K.Q.C.P.I. in 1864, and F.R.C.S.I. in 1865. He served in the militia from May, 1855, to March, 1858, and entered the army as assistant-surgeon on March 10th, 1858, becoming surgeon-major on April 1st, 1873, and retiring with a step of honorary rank on June 20th, 1887. In the regimental days he served successively in the 80th Foot (South Staffords), 37th Foot (Hampshire), 8th Foot (King's Liverpool), 13th Foot (Prince Albert's Somerset Light Infantry), and 9th Foot (Norfolks). During the Indian Mutiny he acted as extra A.D.C. to Sir Henry Havelock at the relief of Lucknow, and in the Shahabad campaign, receiving the medal, and in the Burmese campaign of 1885-87, gaining the medal with a clasp. There seem to be now living only four survivors of the Mutiny in the A.M.D. and two in the I.M.S. In his earlier days he was a man of fine physique, great strength and activity, and a fearless rider. In 1872 he married the only daughter of Mr. James Colthurst of Cork, who died in 1879, over forty years ago. He leaves four daughters. He was a nephew of Colonel Frederick William Hoysted, who served in the American War of Independence, commanded the 59th Foot in the Peninsular, and fought at Waterloo; and a brother of the late Surgeon-General Thomas Hoysted.

DR. RICHARD WILLIAM BROGDEN died at Folkestone on May 4th, aged 67. He was born at Tockwith, near York, the son of Mr. Robert Brogden, and received his medical education at Guy's Hospital. He took the diplomas of M.R.C.S.Eng. and L.R.C.P.Lond. in 1884, and graduated M.B., B.S.Lond. in 1885. He succeeded Dr. G. Hammond in practice at Ipswich about thirty-five years ago, and was elected honorary surgeon to the East Suffolk and Ipswich Hospital in 1887, a post which he retained until he left Ipswich a year ago. He was a member of the South Suffolk Division of the British Medical Association until he removed to Folkestone. He lost his only son in the war; his wife and four daughters survive him.

THE death occurred, on May 8th, of Dr. WILLIAM HENRY ELLIS, of Bradford, at the age of 76. He was educated at Cambridge University and St. Bartholomew's Hospital, and took the diplomas of M.R.C.S.Eng. and L.S.A. in 1866. Soon afterwards he commenced practice at Shipley and remained there until his retirement in 1910. He was for many years consulting surgeon to the Saltaire Hospital, and had served as chairman of the governors of the Salt Trust and a member of the Shipley School Board. He was a member of the West Riding Bench for thirty-one years and for ten years was its chairman. He leaves four sons and two daughters, his youngest son, Captain T. M. Ellis of the West Riding Regiment, having been killed in Flanders early in 1915.

DR. LAWRENCE RAMSAY THOMSON died at Musselburgh, Midlothian, on April 2nd, aged 39. He was the elder son of Dr. A. D. R. Thomson, of Musselburgh, with whom he was working in partnership. He was educated at Edinburgh, where he graduated as M.B. and Ch.B. in 1911. He joined the R.A.M.C. as a temporary lieutenant on September 27th, 1915, and was promoted to captain after a year's service. He served at Malta during the war.

Universities and Colleges.

UNIVERSITY OF CAMBRIDGE.

AT a congregation held on May 7th the following medical degrees were conferred:

M.D.—A. T. Edwards.
M.B., B.Ch.—J. B. Hunter, W. E. H. Banks, H. Gainsborough.
M.B.—H. A. Whyte-Venables.
B.Ch.—W. N. Goldschmidt.

ERRATUM.—In the list of Degrees printed in the JOURNAL of May 14th, p. 722, there was an error. The degree conferred on H. B. Dodwell was that of B.Ch., not M.Ch.

UNIVERSITY OF MANCHESTER.

THE Council has appointed Dr. Albert Ramsbottom, F.R.C.P., physician to the Manchester Royal Infirmary and lecturer on clinical medicine in the Victoria University, to be Professor of Clinical Medicine.

UNIVERSITY OF LONDON.

UNIVERSITY COLLEGE.

THREE public lectures on "The history of chemistry in the nineteenth century," will be delivered in the Chemistry Theatre, by Sir William Tilden, F.R.S., on Fridays, May 27th, June 3rd and 10th, at 5 p.m. The chair at the first lecture will be taken by Professor J. Norman Collic, F.R.S.

ROYAL COLLEGE OF PHYSICIANS OF LONDON.

AN Extraordinary Comitia of the Royal College of Physicians of London was held on Thursday, May 12th, at 5 p.m., the chair being occupied by Sir Norman Moore, Bt., the President.

The following gentlemen, who were elected to the Fellowship at the last meeting, were admitted as Fellows:

C. O. Hawthorne, M.D., C. H. Melland, M.D., J. G. Emanuel, M.D., A. E. Barnes, M.B., J. P. Hedley, M.B., J. A. Torrens, M.D., A. J. Clark, M.C., M.D., A. Feilding, M.D., R. H. Steen, M.D., C. M. Wilson, M.D., G. E. S. Ward, M.D.

Diplomas in public health were granted jointly with the Royal College of Surgeons to twenty-three candidates who had passed the required examinations.

Communications were received from (1) the President and Honorary Secretaries of the Section of Laryngology, Royal Society of Medicine, dated April 8th, 1921, concerning teaching and examination in the subject of oto-rhino-laryngology, and the institution of a special diploma in that subject; (2) the Honorary Secretaries of the Sections of Laryngology and Otolaryngology, Royal Society of Medicine, dated April 30th, 1921, reporting a resolution passed by these sections on the subject mentioned above. These were referred to the Committee of Management for report.

A map illustrating the travels of Harvey in 1636 was received from Sir D'Arcy Power, K.B.E. The thanks of the College were accorded to him for this gift.

The following report, dated April 19th, was received from the Committee of Management:

The Committee of Management have received from Sir Charles Ballance, K.C.M.G., C.B., M.V.O., the visitor appointed by the Royal Colleges to inspect the examinations of the Egyptian Medical School and Hospital, Cairo, a full and interesting report on the examinations and on the teaching in the Medical School and Hospital. In accordance with the authority conferred on them by the Royal Colleges, the Committee have communicated with H.E. the Minister of Education and H.E. the Minister of Public Health with regard to various matters arising out of the report. The Committee are of opinion that the examinations and course of education justify the Royal Colleges in continuing their recognition of the School. The Committee suggest that the Royal Colleges should express to Sir Charles Ballance their appreciation of his valuable services as their visitor.

The thanks of the College were accorded to Sir Charles Ballance.

The Registrar proposed an addendum to the regulation attached to By-law CXVII (which prescribes the times of the several parts of the membership examination), as follows:

"Provided that when the number of candidates renders it desirable the President and Censors may fix such additional times for the clinical and oral examinations as may be required for the proper conduct of the examination."

This was resolved accordingly.

The President then dissolved the Comitia.

ROYAL COLLEGE OF SURGEONS OF ENGLAND.

AN ordinary Council was held on May 12th, when Sir Anthony Bowlby, President, was in the chair.

Issue of Diplomas.—Diplomas of Membership were granted to the 103 candidates found qualified at the recent examinations;

the names were published in the report of the proceedings of the comitia of the Royal College of Physicians of London (May 7th, p. 690). Diplomas in public health were granted, jointly with the College of Physicians, to 23 candidates. Diplomas in tropical medicine were granted, jointly with the College of Physicians, to 21 candidates.

Vacancies on the Court of Examiners.—The President reported that the terms of office of Mr. R. Lawford Knaggs and Mr. J. Hutchinson as members of the Court of Examiners would expire on June 8th next, and that the vacancies thus occasioned would be filled up at the ordinary council on June 9th.

ROYAL COLLEGE OF PHYSICIANS OF IRELAND.

AT a meeting of the President and Fellows of the Royal College of Physicians of Ireland, held in the College Hall, Kildare Street, Dublin, on May 6th, Dr. Harold Pringle, King's Professor of the Institute of Medicine in the School of Physic, Ireland, was admitted a Fellow of the College, and Dr. Samuel Denis de Vos, of Ceylon, was admitted a Licentiate in Midwifery.

CONJOINT BOARD IN SCOTLAND.

THE following candidates have been approved at the examinations indicated:

D.P.H.—T. Pullar, Janet B. Higgins. Part I: Ellen D. Anderson, W. Cunningham, R. J. Peters, A. Davidson, Mary C. Walker, Marguerite L. Sclanders, W. H. Wallace, W. D. MacKinnon, E. M. E. Cumming, A. M. Davidson, C. L. Miller, D. Heard, D. Fyfe, W. McKendrick, Helena E. Barrett, S. J. Henderson, J. Frew.

CONJOINT BOARD IN IRELAND.

THE following candidates have been approved at the examination indicated:

FINAL PROFESSIONAL.—Mary Boland, Lucia H. H. Byrne, T. Cooney, B. J. Coyne, J. A. Cusack, Edith M. L. Dodd, A. C. Femonde, P. Gaffney, S. A. Gailey, J. W. E. Graham, S. J. Halpin, T. J. Kerr, J. J. McHenry, P. Moylan, J. J. O'Sullivan, J. Tehan (honours).

Medical News.

THE Senate of the University of Glasgow has resolved to confer the honorary degree of Doctor of Laws (LL.D.) upon Dr. Precland Fergus, President of the Royal Faculty of Physicians and Surgeons of Glasgow.

DR. J. F. GASKELL, physician to Addenbrooke's Hospital, Cambridge, has been appointed honorary pathologist to the hospital in succession to Dr. Aldren Wright.

A MEETING of the School Medical Service Group of the Society of Medical Officers of Health will be held on Saturday, May 28th, at 2.15 p.m., at the School Clinic, Great Charles Street, Birmingham. Members of the School Medical Service who are not members of the society will be welcome as visitors. The honorary secretary of the group is Dr. A. Ashkenny, Soho Hall, Birmingham.

A SPECIAL course of ten lectures on advanced surgery will be given in the Surgical Unit Lecture Theatre of the London Hospital, on Tuesdays and Thursdays, at 4.15 p.m., beginning on June 7th. The course is open to post-graduates and senior students.

PROFESSOR C. S. SHERRINGTON, President of the Royal Society, and Dr. H. K. Anderson, F.R.S., Master of Gonville and Caius College, have been elected members of Athenaeum Club under Rule 2, which empowers the annual election by the committee of a certain number of persons "of distinguished eminence in science, literature, the arts, or for public service."

THE ordinary quarterly meeting of the Medico-Psychological Association of Great Britain and Ireland will be held at the Maudsley Hospital, Denmark Hill, S.E., under the presidency of Dr. W. P. Menzies, on Tuesday, June 7th. Sir Frederick Mott, F.R.S., will deliver the second Maudsley lecture at 4.30 p.m.

ON May 25th Dr. C. M. Wilson will read a paper before the Royal Society of Arts on "Some effects of the war on industrial unrest," and on May 30th Sir Kenneth Goadby will read a paper on "Industrial disease and immunity." Each paper will be given at 8 p.m. at the house of the society, John Street, Adelphi, W.C.2, and discussions will follow.

TWENTY THOUSAND cases of cholera, 9,000 of which were fatal, have recently been certified in Corca.

THE Japanese Government have arranged that the principal trains leaving Tokio shall carry a medical officer.

THE Soviet Tartar Republic at Kasan has formed a medical institute with a special section for the hygiene of labour.

THE Council of British Ophthalmologists presented its annual report to a meeting held on May 7th at the house of the Royal Society of Medicine. It recorded that at the beginning of the session 1920-21 Mr. J. B. Lawford was elected president in place of Sir Anderson Critchett, who filled that office during the first two years of the Council's work; Sir George Berry and Mr. E. Treacher Collins were elected vice-presidents, Mr. J. Herbert Fisher honorary treasurer, and Mr. Leslie Paton honorary secretary. The report notes with gratification that special examinations in ophthalmology have recently been established in connexion with two surgical degrees—the M.S. Lond. (Ophthalmology) and M.S. Vict. Univ., Manch. (Ophthalmology)—and the diploma in ophthalmic medicine and surgery of the English Conjoint Board; further, a committee of the Royal College of Surgeons of England is considering the question of creating a higher form of diploma in connexion with the Fellowship of the College. During the past session the council issued a report on the need for institutional treatment of children with contagious eye disease. This was forwarded to the Ministry of Health and a deputation was received by Sir George Newman on behalf of the Minister. In consequence of this, beds are now available at the Metropolitan Asylums Board ophthalmia school at Swanley for London County Council school children suffering from ophthalmia or other contagious diseases of the eye. The Council has had under consideration the question of sight-testing by opticians, and has prepared a report on the subject. The Council has also prepared a report on the notation of cylinder axes, and still has under consideration the question of the standardization of test types. A committee appointed to consider the Report of the Consultative Council of the Ministry of Health, in so far as it is likely to affect ophthalmic surgeons, has gathered a considerable amount of information as to the work done by ophthalmic surgeons for various public and state authorities. Another committee is considering the question of examination, treatment, and report of cases referred by public authorities to ophthalmic surgeons in voluntary hospitals.

Letters, Notes, and Answers.

As, owing to printing difficulties, the JOURNAL must be sent to press earlier than hitherto, it is essential that communications intended for the current issue should be received by the first post on Tuesday, and lengthy documents on Monday.

ORIGINAL ARTICLES and LETTERS forwarded for publication are understood to be offered to the BRITISH MEDICAL JOURNAL alone unless the contrary be stated.

CORRESPONDENTS who wish notice to be taken of their communications should authenticate them with their names—of course not necessarily for publication.

AUTHORS desiring reprints of their articles published in the BRITISH MEDICAL JOURNAL are requested to communicate with the Office, 429, Strand, W.C.2, on receipt of proof.

In order to avoid delay, it is particularly requested that ALL letters on the editorial business of the JOURNAL be addressed to the Editor at the Office of the JOURNAL.

THE postal address of the BRITISH MEDICAL ASSOCIATION and BRITISH MEDICAL JOURNAL is 429, Strand, London, W.C.2. The telegraphic addresses are:

1. EDITOR OF THE BRITISH MEDICAL JOURNAL, *Aitiology, Westrand, London*; telephone, 2630, Gerrard.
2. FINANCIAL SECRETARY AND BUSINESS MANAGER (Advertisements, etc.), *Articulate, Westrand, London*; telephone, 2630, Gerrard.
3. MEDICAL SECRETARY, *Medisecra, Westrand, London*; telephone, 2630, Gerrard. The address of the Irish Office of the British Medical Association is 16, South Frederick Street, Dublin (telegrams: *Bacillus, Dublin*; telephone, 4737, Dublin), and of the Scottish Office, 6, Rutland Square, Edinburgh (telegrams: *Associate, Edinburgh*; telephone, 4361, Central).

QUERIES AND ANSWERS.

"PENSIONS" asks if any cases of "double appendix" are recorded. Operating recently on a case after removal of what appeared to be a normal appendix, on turning the caecum round another appendix came into view, with a definite meso-appendix chronically inflamed and with a very diminished lumen. Unfortunately no histological examination was made. The second "appendix" was two inches long, and did not seem like an intestinal diverticulum.

INCOME TAX.

"N. P." is a whole-time medical officer of the Ministry of Pensions, and has been refused a deduction by the local inspector for the expense of his subscriptions to the Association and of purchases of books to maintain his standard of medical knowledge.

* In our opinion he is entitled to a reasonable deduction for such expenses as being incurred wholly, exclusively, and

necessarily in the performance of his duties; they represent the maintenance cost of his professional equipment. His method of procedure is by way of appeal to the local Commissioners through notice, given to the local inspector, of objection to the assessment made on his salary.

"PUZZLED" is employed in a whole-time capacity under the Ministry of Pensions. He lives some distance from London, and has to travel up daily for his work. He asks if he is entitled to deduct the cost of a season ticket.

* No—unless he also has work for the Ministry of Pensions which must be done at the place of residence. A case in the High Court decided some years ago that the expense of travelling to the place of employment is not incurred in performing the duties of the office.

"H. D." sold his pre-war 8 10 h.p. Darracq car for £30 and his motor cycle for £20, and on resuming civilian work purchased a 11.9 h.p. Phoenix car for £450. He inquires whether he can charge the sum of £400—that is, £450 less the £30 and £20—as motoring expenses.

* In our opinion, yes.

LETTERS, NOTES, ETC.

THE Royal Insurance Company has issued a waistcoat pocket edition of the *Rules of Golf*, which includes recent important changes in the rules and interesting notes on the question of the size and weight of the ball. There is a comprehensive index, and many medical golfers may like to have the booklet, which is obtainable from any of the company's offices.

THE PREVENTION OF URETHRAL STRICTURE.

R. M. W. BROWDY (London, W.) writes: I read with interest in your issue of May 14th the article by Mr. Ginseppi on the treatment of urethral stricture. He deplors the "paucity of papers on the subject," and also that "so little has been done to modernize its treatment." I cordially agree, and carefully scanned the paper to find if any mention was made regarding preventive treatment. It is deplorable that so little attention should be paid to this point. The majority of cases are due to gonorrhoea, and badly treated gonorrhoea. If medical men would pay more serious attention to the treatment of acute gonorrhoea and not rely upon cessation of discharge or the examination of a smear as a criterion of cure and freedom from organic change, but would carefully examine the urethra for patches of infiltration in its early stage and thoroughly dilate with sounds and expanding dilators, stricture would be a relic of the past.

HERPES AND VARICELLA.

DR. O. HILTON (Northwood, Middlesex) writes: A., a carpenter, and B., a painter, were working at the same job. Each developed shingles on his right arm. A. first felt pain on April 22nd; B. first felt itching on April 25th. A. discovered a herpetic rash on April 24th, and came to see me on April 27th; B. came to me with a well-developed eruption on May 2nd. On May 11th, seventeen days after A. noticed his spots, an eruption was seen on his youngest child, and to-day, May 13th, I found the child suffering from a quite typical attack of chicken-pox.

VACANCIES.

NOTIFICATIONS of offices vacant in universities, medical colleges, and of vacant resident and other appointments at hospitals, will be found at pages 23, 24, 25, 28, 29, and 30 of our advertisement columns, and advertisements as to partnerships, assistantships, and locum tenencies at pages 26, 27, and 31.

THE appointments of certifying factory surgeon at Athlone (Westmeath) and Brecon (Brecon) are vacant.

SCALE OF CHARGES FOR ADVERTISEMENTS IN THE BRITISH MEDICAL JOURNAL.

	£	s.	d.
Six lines and under	0 9 0
Each additional line...	0 1 6
Whole single column (three columns to page)	7	10	0
Half single column	3 15 0
Half page	10 0 0
Whole page	20 9 0

An average line contains six words.

All remittances by Post Office Orders must be made payable to the British Medical Association at the General Post Office, London. No responsibility will be accepted for any such remittance not so safeguarded.

Advertisements should be delivered, addressed to the Manager, 429, Strand, London, not later than the first post on Tuesday morning preceding publication, and, if not paid for at the time, should be accompanied by a reference.

NOTE.—It is against the rules of the Post Office to receive *poste restante* letters addressed either in initials or numbers.

A Clinical Study OF THREE CASES OF HEART-BLOCK.

BY
T. WARDROP GRIFFITH, C.M.G., M.D., F.R.C.P.,
PROFESSOR OF MEDICINE, UNIVERSITY OF LEEDS; HONORARY
PHYSICIAN, GENERAL INFIRMARY AT LEEDS.

THE three cases of heart block which form the subject of this communication present certain features of interest. In the first, a block which remained complete for a long period suddenly broke into a two to one block and ultimately passed off altogether. In the second case, though the vexed and difficult question of whether the block was partial or complete arose from time to time, there certainly were periods when the block was of the former character, and it was mainly during these that the tracings I discuss here were taken. The phenomenon of ventricular "escape" is shown; an auscultatory sign is mentioned to which I have elsewhere referred; the effects of amyl nitrite and of atropine are discussed, and tracings are shown which demonstrate the occasional occurrence of "flutter" of the auricle. The third case is put on record not only as an example of complete heart-block with an unusually slow ventricular rhythm, but on account of the large number of attacks of the Adams-Stokes character, during some of which satisfactory tracings were obtained. In this case also, simultaneous tracings of the pulse and of the respiration showed a remarkable relation between the periods of asystole and those of the apnoeic phases of the Cheyne-Stokes respiration when that was present.

CASE I.

W. R., aged 60, a gardener, was admitted under the care of my colleague, Dr. Watson, to whom I was indebted for permission to study the case and who has also kindly allowed me to publish the results of my investigations. Four months before admission he felt giddy when at work; this feeling was transient, but recurred in a fortnight and then almost every day. He became very conscious of the beating of his heart and volunteered the information that its action had become very infrequent. He was a temperate man and moderate in the use of tobacco. He had had rheumatic fever when he was 38 years of age; there was no evidence of syphilis. His complaint was of some measure of breathlessness and of a feeling of oppression over the heart. The arterial walls were thickened; the apex beat was forcible and it was external to the nipple line; a systolic bruit was audible with its maximum at the apex and was also heard at the aortic and pulmonary areas, but there was no clear evidence of a valvular lesion. The pulse was regular and infrequent; from the date of his admission till the twenty-eighth day of his stay in hospital the pulse never exceeded 36, and it was counted as low as 24. On the twenty-eighth day of his stay in hospital he detected a change in the frequency of the heart's action. On counting the pulse he found it was 48; shortly before he had counted it at 24, and his report at a later period of the same day was that "it was running backwards and forwards from 44 to 68 and 70 and upwards, but was never keeping to one regular beat."

The tracings shown in Figs. 1 to 5 were taken on the same day during the former of these two phases. The

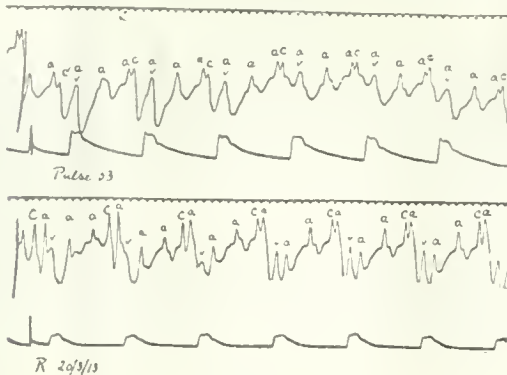

FIG. 1.

upper tracing of Fig. 1 might readily be interpreted as an example of a partial block in which every third auricular stimulus passes to the ventricle. The lower

tracing, taken by itself, might also bear that interpretation, though an undoubted lengthening out of the a-c interval as the tracing is read from left to right ought to arouse one's suspicions of the block being a complete one. When, however, the upper and lower tracings are viewed in relation to one another, the evidence in favour of the block being a complete one is very strong. The a-c interval is much longer in the lower than in the upper tracing, and a partial block would not account for this. On the other hand, if the block were a complete one it is clear that a temporary acceleration of the auricular rate would result in this interval being lengthened. The diagram in Fig. 2 explains this.

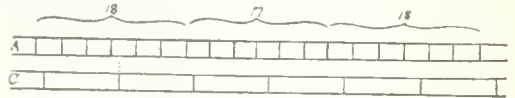

FIG. 2.

I have elsewhere¹ discussed the difficulties, sometimes I believe insuperable, which await the attempt to distinguish between a partial and a complete auriculo-ventricular block. In this case it is not a difficult task. If, in any case where the question arises of there being a two to one or a three to one heart-block, a long tracing is taken, and it is found that variations in the frequency of the auricular contractions are slavishly followed by similar variations in the ventricular rate, this will be accepted as confirming the partial nature of the block. If, on the other hand, in spite of variations in the auricular rate, the ventricle goes on the even tenor of its way and beats with perfect regularity, we may regard the block as being complete. It is true that in cases of complete block there is nothing to prevent the auricular rate happening to be exactly twice or three times that of the ventricular rate, but the arm of coincidence would require to be a very long one for this relationship not to vary in a tracing taken over a period of many minutes. Still I have seen it occur, and it is sometimes a good plan to get the patient gently to inhale some ammonia, which has the effect of increasing the auricular rate. Light may thus be thrown on the relationship between the auricular and ventricular contractions. Fig. 3 shows the result of this

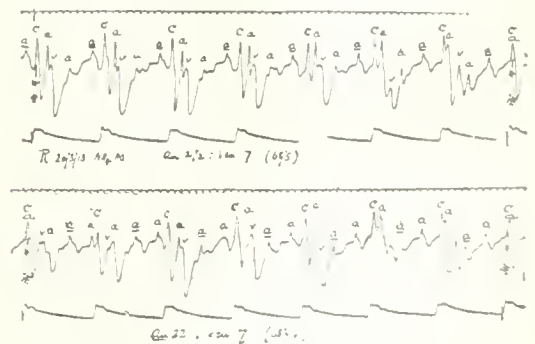

FIG. 3.

experiment. At a time when the auricle was beating exactly three times the rate of the ventricle, the patient was directed to inhale a little ammonia. For some time, but only for the period of a few beats, the auricle went on beating at the same rate; then the beats became rather more frequent. As it was observed that the ventricular rate was not affected in the slightest degree, confirmation was obtained of the complete character of the block. In the upper tracing of Fig. 3 it will be seen that every third auricular wave—and this I have underlined—"falls back" from the "c" which comes after it, and in this way the seven radial periods between the two asterisks are equal to twenty-one and a half interauricular periods. With the increase in auricular rate in the lower tracing it is seen that seven radial periods correspond to twenty-two interauricular periods. Throughout, the ventricle beats with remarkable regularity.

But in this case the completeness of the block was obvious without artificial means. Later in the day the

tracing shown in Fig. 4 was obtained. The block is manifestly a complete one, and it will be seen that at every fourth cycle auricle and ventricle contract at the

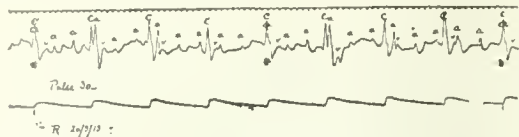

FIG. 4.

same moment. While this relationship prevailed a tracing was taken over the apex beat, and this is shown in Fig. 5. The position of some of the auricular waves is open to doubt, but in the case of the second and sixth ventricular

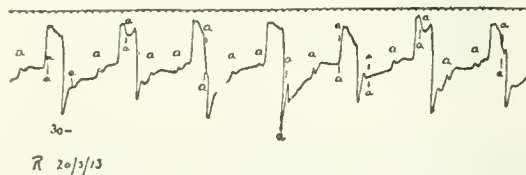

FIG. 5.

impulses it is clear that the systolic plateau is dimpled by the drag of the contracting auricle, while in the case of the third and seventh the end of the plateau is modified. Some may see a difficulty in accepting the view that the plateau of a powerfully contracting ventricle can be dimpled by the action of the auricle, but this dimpling of the plateau does not represent any victory of the auricle over the ventricle. Here there is no question of which is the stronger; the greater part of the ventricular force is engaged in driving blood into the aorta, a small part of it only in maintaining the forward thrust of the apex. This contracting ventricle is drawn back as a whole from the chest wall by the drag of the auricle in systole.

The sudden increase in the pulse rate noticed by the patient on the twenty-eighth day of his stay in hospital has been mentioned; for about thirty-six hours the rate varied from about 36 to 68 or 70. On the day on which the alteration in rate was observed the tracing shown in Fig. 6 was obtained. Calculated from the slow rhythm

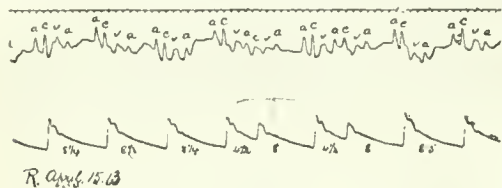

FIG. 6.

the pulse rate is seen to be about 36 per minute. If the condition is still one of complete block, we must regard the fifth pulse wave as the expression of an extra-systole of the kind described by Wenckebach in complete heart-block; and this view would be strengthened by there being no lengthening of the a-c interval which leads to this fifth systole as might be expected if two auricular stimuli got through in succession, as well as by the next radial period being practically equal to the customary long radial intervals. Still I incline to think that the condition is really one of a two to one heart-block with the occasional passage of two auricular stimuli in succession, and this

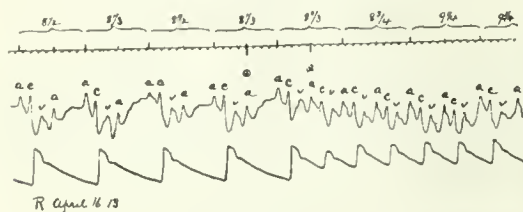

FIG. 7.

appears to be borne out by the two tracings which I took the following day. Figure 8 shows what I take to be a change from a two to one rhythm to one in which every auricular stimulus passes to the ventricle. Calculated on the slow rate the pulse is about 36; when every stimulus

gets through the auricular rate very soon falls slightly, and this is reflected in the rate of the ventricle, for towards the end of the tracing it will be seen that the time

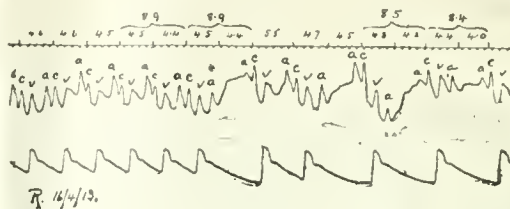

FIG. 8.

occupied by two radial periods is rather greater than that occupied by one period of the slow rate. Figure 8 shows the converse of this—a change, that is to say, from the fast rhythm to the slow. Here it is to be observed that shortly after the blocking of every second stimulus from the auricle, the auricular rate increases. I think that in these variations we may see an expression, though at first sight not perhaps a very obvious one, of the well known relationship between the blood pressure in the medulla and the frequency of the cardiac action. When the blood pressure rises the cardiac systoles are lessened in number by vagus influence; when it falls, the removal of that influence leads to their increase. This influence of the vagus is of course exercised primarily on the auricle, and it is the rhythm of this chamber which must be studied in this connexion. In Fig. 7 the sudden increase in the number of systoles due to the passing of the block will tend to raise the blood pressure; this in turn will lead to a slowing of the auricle, which will result in two radial pulse periods of the rapid phase being slightly greater than one of the slow phase. So also in Fig. 8 the blocking of auricular stimuli after the middle of the tracing will primarily tend to lower arterial blood pressure, and the quickening up of the auricle which soon follows may be regarded as being the result of this, and also an adaptive effort to combat the lowering of pressure.

Two days afterwards the condition was that shown in Fig. 9. Every auricular stimulus passes through, but there remains some lengthening of the a-c interval. There was no recurrence, and the man went home after a few days of this normal rhythm. I heard from his

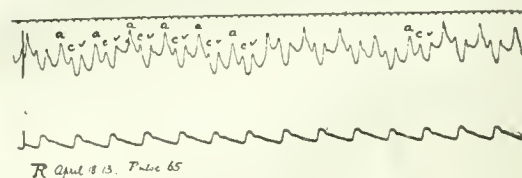

FIG. 9.

medical man some time afterwards that he had again had an infrequent pulse for some three weeks; that this suddenly passed off, the pulse rising to 120 and then in ten minutes falling to 80. He died some months after this without any obvious cardiac symptoms, and I understand that he had abdominal discomfort and emaciation.

CASE II.

A woman of about 38, who was admitted under my care complaining of dyspnoea and who was conscious of the cardiac action. The systolic blood pressure was 250 mm. of mercury and sometimes higher, and there was a trace of albumin in the urine. The pulse was infrequent, sometimes regular and sometimes irregular. The degree of irregularity was sometimes enough to strike one at once, and on some occasions it was so slight that it could not be detected without instrumental means.

The first tracing which I show from this patient (Fig. 10) reveals an impairment of conductivity, for not only is every second auricular stimulus blocked, but the passage of those which reach the ventricle is delayed. I find it is often an advantage to measure from the summit of the "a" wave to the radial rise in estimating conductivity rather than to adopt the usual measurement from the beginning of the auricular wave to the beginning of the carotid.¹ For reasons which I need not mention here the beginnings of both these waves may be obscured. It is clear that the block is not a complete one and that the auricular rate is dominating the ventricle. In the first

place the ventricular rate is 47, which is high for a complete block, and in the second place the relationship which is shown in the figure between auricle and ventricle was preserved over a long tracing.

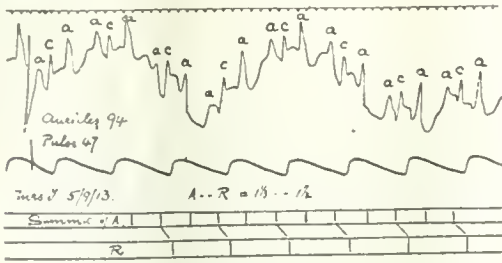

FIG. 10.

In the next tracing (Fig. 11) the auricle is beating less frequently—that is to say, at 54 and not at 94 a minute. At the time this tracing was made most of the auricular stimuli got through in spite of the fact that some of them were premature, a condition inimical to transmission; but

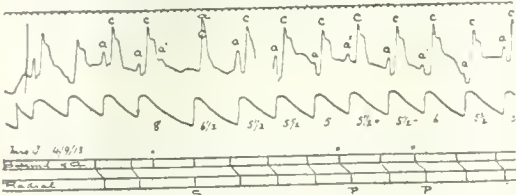

FIG. 11.

at one point it will be seen that a contraction of the auricle has indeed failed to reach the ventricle, probably because it is more premature than the others which are only associated with an increase in the a-c interval. With the auricle beating at 54 instead of at 94 the blocking of one stimulus from the auricle will give the ventricle a much longer time in which to build up its stimulus material to the flash point, and this is more than enough, for its systole occurs eight fifths of a second after the previous beat—that is, as it so happens, at the same time as the auricle contracts, and of course at a time that it cannot be attributed to this event. This phenomenon is not uncommon in cases of partial block and is by Einthoven referred to as "ventricular escape."

The next tracing (Fig. 12) shows the blocking of stimuli becoming rhythmical. One of these is premature. The

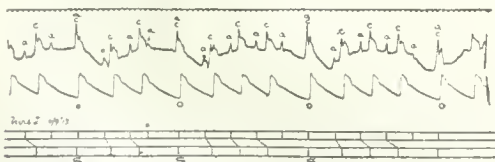

FIG. 12.

escaped ventricular contraction occurs synchronously with the auricular contraction, and this gave rise to an alteration in the first sound of the heart. There was usually a faint systolic bruit at the apex, but when in consequence of ventricular escape auricle and ventricle contracted at the same time the first sound became loud and thumping and the bruit was not audible. When in a case of infrequent cardiac action the first sound shows this alteration, either rhythmically or irregularly, one may strongly suspect either a partial block with escape of the ventricle or a condition of complete block. The black dots under the radial tracing indicate beats which were announced as being loud by an observer who was confining his attention to that one point. He did not give his signal, however, at one point when the two cavities contracted together, and this I have indicated by a small circle.

Effect of Amyl Nitrite.

As I had found that inhalation of amyl nitrite caused a partial block to be overcome, I decided to make the test in this case, but on examining the patient before doing so I found the heart so nearly regular that I was unable to make out the slight irregularity which existed without

instrumental means. I also found that the characters of the pulse in the veins of the neck had entirely changed (see Fig. 13). The waves referable to the auricle were now 266 per minute, while the ventricle was beating so

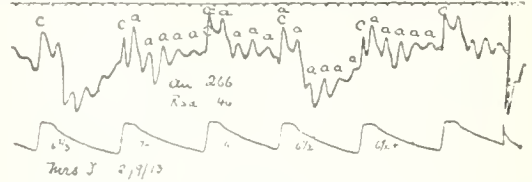

FIG. 13.

infrequently that the pulse was about 46 and the radial spaces varied from about six to seven fifths of a second. The condition was clearly that known as "flutter," and for reasons I need not mention at present I am in some doubt whether the block was a complete or a partial one. Inhalation of amyl nitrite did not at first produce any effect on the auricle, which continued to give rise to 266 waves per minute. The radial pulse increased to 55 (see Fig. 14). If the block was a partial one this might

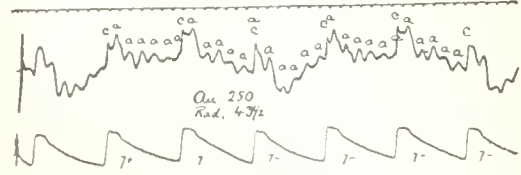
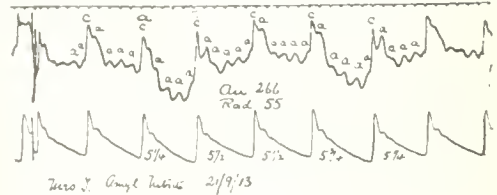

FIG. 15.

be due to auricular impulses getting through more frequently from the improvement in conductivity which occurs from amyl nitrite; if, on the other hand, the block was a complete one, the action on the ventricle must be of a more direct nature. In a few seconds the auricular waves fell to 250 and the pulse to 43½ per minute.

I waited till this condition of auricular flutter had passed off before I considered that I had an opportunity of trying

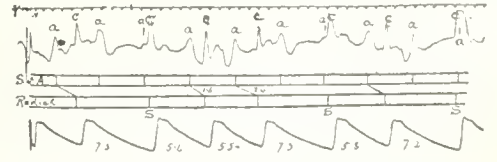

FIG. 16.

the effect of amyl nitrite on conductivity. In the upper tracing of Fig. 15 it will be seen that the auricle had resumed its normal action; it was beating at 65; there were escaped beats of the ventricle following on blocking of stimuli, and the a-c interval varied from 1.6 to 2.4 fifths of a second. Inhalation of amyl nitrite at once increased the auricular rate to 91 per minute. Yet in spite of this great demand on the conducting function of the bundle every impulse was transmitted; not only so, but the time of transmission was lessened, as will be seen on comparing the two tracings. The next tracing (Fig. 16) shows that the effect on the conducting function of the bundle began to pass off before the effect on the auricular rate; for

while this remains at 91 we find a progressive lengthening of the *a-c* interval until this culminates in a block. This tracing also gives evidence that the inhalation of amyl

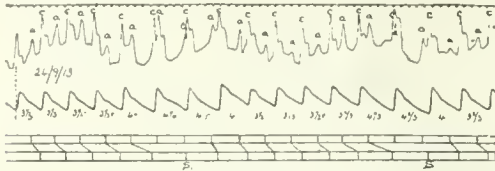

FIG. 16.

nitrite increases the rate of the idio-ventricular rhythm, for it appears that if the ventricle is left to itself it enters into contraction at the end of a period of about four and a half fifths of a second.

Effect of Atropine.

On another day I tried the effect of atropine on the function of conductivity. However, on taking a preliminary tracing I found that the auricle was again in a condition of flutter. This passed off in about an hour, and the two tracings seen in Fig. 17 were taken. The

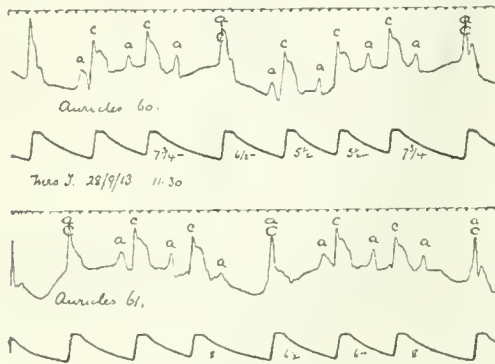

FIG. 17.

auricles were beating at 60 and 61, and every fourth or fifth stimulus was blocked. One-fiftieth of a grain of atropine sulphate was then injected subcutaneously; in fifteen minutes all the stimuli from the auricle passed through to the ventricle. This is seen in the upper tracing of Fig. 18. Some impairment of conductivity is indeed

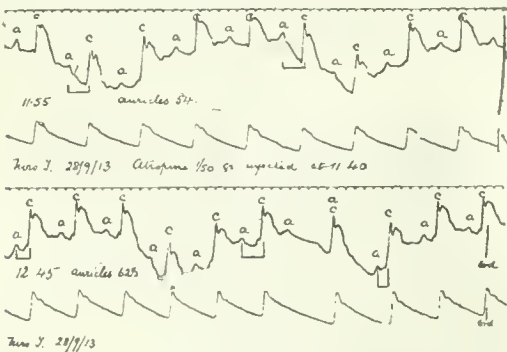

FIG. 18.

still apparent in the lengthened *a-c* interval, which slightly exceeds the longest intervals in the previous tracing, but in view of the fact that every stimulus is now passing the comparison is not quite a fair one. It will be noted that the auricles are now beating at 54 instead of at 60. This is not the first time I have found atropine produce this effect in the earlier stage of its action,² and it might be suggested that the passing off of the block is attributable to a lessened demand on the function of the conducting structures in consequence of this slowing of rhythm. The lower tracing gives the answer to this, because here the auricular rate has gone up to rather more than it was before the injection, and yet, though there is some return of blocking of stimuli, there are long runs where every stimulus reaches the ventricle. Here also, as with amyl nitrite, the effect of the drug is more evanescent in respect of conductivity than in respect of the auricular rate.

SUBSEQUENT HISTORY OF CASE II.

The patient remained in hospital many months, and a great many tracings were taken. A very common rhythm was that shown in Fig. 10, with every second auricular stimulus blocked. At other times the block was clearly a complete one, with a regular ventricular rate of 37 to 40—a rate which is in harmony with the time at which the sporadic escapes of the ventricle have been seen to occur.

About twelve months after her discharge from hospital she was again admitted, having had a sudden attack of left hemiplegia without any loss of consciousness. Both arm and leg were affected, but the weakness was not great; at first there was neither hemianaesthesia nor hemianopsia, but the hemiplegia increased and soon became associated with both these symptoms. In the course of a few days she suddenly became unconscious; very soon Cheyne-Stokes respiration came on, followed by death. During the last days of her life the tracings showed a condition of partial block in which the passing of a stimulus was regularly followed by the blocking of the next, which in turn led to an escape of the ventricle. In this way the radial tracing presented a series of long and short periods, the long ones being rather less than two interauricular spaces, and the short ones being rather more than one interauricular space. Shortly before she died the pulse went up to 85, and though no venous tracing was taken there can be no doubt that, so far as the actual passing of stimuli is concerned, the block had disappeared.

CASE III.

T. M., a labourer, aged 50, was admitted under Dr. Churton, to whom I am indebted for permission to use the case. Alcoholic excess for years; no history of syphilis. Three weeks before admission, at a time when he was not exerting himself at all, he had an attack of loss of consciousness and is said to have been convulsed. He was able to get home by himself. On admission he was found to be the subject of general atheroma; there was great enlargement of the heart; the blood pressure rose during the systole to 210 and the pulse was anacrotic. The radial pulse was regular and about 22 per minute. At the apex a systolic bruit was heard which varied very much in distinctness from beat to beat, and which at times was inaudible, the first sound being then loud and thumping. This last sign, pointing as it does to a simultaneous systole of the auricle and ventricle with some of the heart-beats, led to a diagnosis of complete heart-block.

Figure 19 shows tracings of the jugular pulse in the upper and of the apex beat in the lower record, the radial pulse

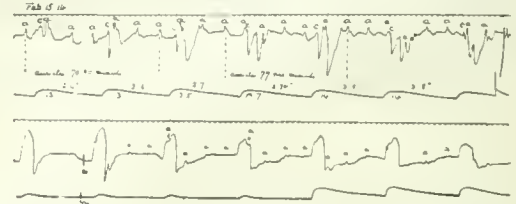

FIG. 19.

being also shown in each case. It will be seen that though the auricular rate varies from 70 to 77, the ventricular rate is not affected; the block is a complete one. He then began to have long periods of asystole with, after some little time, tonic and clonic convulsions following on loss of consciousness. Of these attacks I saw an immense number; the majority of them conformed to the following description, which I quote from my notes made at the time:

"While lying quietly in his usual condition, the pulse stops quite suddenly; he becomes pale, and looks as if he were going to die. I think the respiration becomes less full. Then, after a varying period, usually about fifteen seconds, he becomes unconscious. To test this I was in the habit of getting him to repeat numbers or letters after me; he would become confused in his utterance over one or two letters or numbers, and then all response would cease. Following very soon on the loss of consciousness, in about two or three seconds that is to say, he begins to have slight tonic spasm, the face being usually turned from the left towards the right, and the head slightly raised from the pillow. Some alteration of expression of the face suggestive of pain is usually noticed. Then, quite suddenly, and before the disappearance of the tonic spasm, the pulse returns, the first beat as a rule being quite strong and full; at once the face assumes its normal colour, and in a second or two becomes redder than usual. About the same time the tonic spasm, which lasts only a few seconds, passes off, and the head may again rest on the pillow. Then, almost at once, clonic

spasms of moderate violence come on, and after these have lasted a few seconds he usually puts his hands to his head and complains in a confused voice of pain in the head before all the spasm has passed off."

mission, tended to become less frequent, and Fig. 21 was taken at a time when the pulse rate had fallen to 9 per minute. Sometimes long pauses of ten or eleven seconds

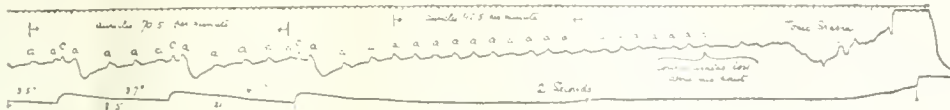

FIG. 20.

The tracing shown in Fig. 20 was taken during one of these attacks. The increase in the auricular rate during

occurred, and towards the end of these pallor, without unconsciousness, prevailed.

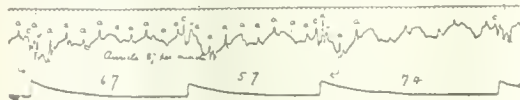

FIG. 21. Pulse rate, as calculated from eight spaces, 9 per minute

FIG. 21.

the period of asystole is well seen, and is doubtless the expression of the fall in arterial pressure. The duration of

Apparently in connexion with the long periods of asystole and here I refer to those which were not associated with convulsion or with loss of consciousness—Cheyne-Stokes respiration was present. The relation was constant and peculiar, and it is shown in Fig. 22; the period of apnoea does not begin until after that of asystole has passed off; there is sometimes an interval of a few seconds between the two phenomena; they never coincide in time. I am not aware that this relationship has been formerly noted. In this tracing the return of the pulse is of the staircase variety. I have looked through my many

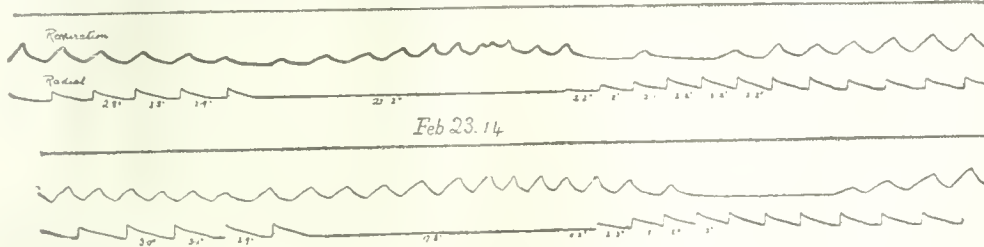

FIG. 22.

asystole is twenty-one seconds; the point of time at which consciousness was completely lost is indicated, and it will be seen that the tonic spasm interfered with the record from the venous pulse.

tracings, but find, as I have already mentioned, that as a rule the pulse returns with a full beat.

His pulse, which as I have said was about 22 on ad-

REFERENCES.

¹Heart, vol. iii, No. 2. ²Quarterly Journal of Medicine, vol. iii No. 10.

A Lecture

ON

CAPILLARY PRESSURE AND OEDEMA.*

BY

LEONARD HILL, M.B., F.R.S.

It is generally held, both in physiological and pathological teaching, that the transudation of fluid through the wall of the capillaries is due to the pressure of the blood within these vessels—that is to say, to the force of the heart beat. The average capillary pressure is taken as something between 20 and 30 millimetres of mercury, and it is suggested that this pressure is sufficient to overcome the osmotic force which is found to be exerted through gelatine membranes by the proteins of the blood and separate the water and crystalline substances which pass out from the capillaries into the tissues. According to the modern theory of the secretion of urine, it is assumed that such filtration takes place through the Malpighian capsules, and it is supposed that to maintain this filtration and to overcome the osmotic pressure of the colloids the pressure within the glomerular capillaries is about 20 per cent. less than that in the aorta. The assumption that there is any such high pressure within the capillaries I believe to be erroneous.

My attention was first drawn to capillary pressure some twenty-five years ago when I was inquiring into the principles of the cerebral circulation. I measured the pressure of the brain against the skull wall by means of a tube filled with water and closed by a thin rubber membrane, which was so screwed into a trephine hole that the rubber membrane came into contact with the bulging brain; the tube was connected with a glass tube

containing an air-bubble index, and this by a T-piece with a pressure bottle and a manometer. When the tube was screwed in and the rubber membrane came in contact with the brain, the air-bubble index was pushed out from the zero pressure position. On raising the pressure bottle, so as to restore the air bubble to the zero position, the manometer recorded the pressure required to push in the bulging brain, and restore it to its natural position within the closed skull cavity. The pressure of the brain against the skull wall is due to the distension of the cerebral arterioles and capillaries by the heart, and my method, I believe, gave me a measure of the pressure in these vessels.

In the anaesthetized animal lying in the horizontal position this pressure was about 5-10 mm. Hg, and was the same as the pressure measured in the torcular Herophili; in the dog this was a bony cavity, and therefore suitable for the insertion of a tube and the measurement of the cerebral venous pressure. Trephining the lamina of the atlas and screwing in a tube there, I obtained the pressure of the cerebro-spinal fluid. I found the pressure of the cerebro-spinal fluid, cerebral venous pressure, and the pressure of the brain against the skull wall were the same and varied together, and I concluded that the cerebral capillary pressure is only some 5-10 mm. Hg, and is practically the same as the pressure in the cerebral veins; only the least difference is required to maintain the flow. I may point out here that whether blood is extravasated within the skull or we are dealing with a depressed fracture, either the blood clot or the depressed bone expresses blood out of the brain contiguous to it, and occupies the room of this blood, and so raises the circulatory pressure up to arterial pressure in adjoining parts. The clot or the bone do not continue to press, but occupy room. The increased brain pressure is due to the shutting up of the capillary-sized vessels.

The brain is enclosed within a rigid case—the skull—and the total content cannot vary, but there may be more blood in the brain and less tissue substance and cerebro-spinal fluid on the one hand, while on the other hand

* Given at St. Mary's Hospital in the Institute of Pathology and Research during the course on Pathological Research in its Relation to Medicine.

there may be less blood, and more fluid or tissue substance. The arteries may dilate and the tissue cells may swell, and these together may confine the size of the veins and raise the pressure in the capillaries, so that there is a relatively rapid flow through a more rigid set of vessels, or the arteries and the tissue cells may shrink and the veins dilate, so that there is congestion of these and a sluggish flow. In a healthy state of activity the cerebral arteries are moderately expanded, the tissue cells in a normal state of turgescence, the veins narrow, and the flow of blood and oxygenation good. In a state of collapse the opposite conditions hold: arterial pressure is low, veins congested, or there is more fluid in the spaces, and blood flow is slow and oxygenation poor.

It has commonly been taught that in the eye the aqueous fluid, which is at a pressure of some 25 mm. Hg, is filtered through the walls of the capillaries, the blood within those vessels being supposed to be at a pressure of 20 to 30 mm. Hg higher. That the pressure of the aqueous balances the capillary pressure in the iris is shown by the fact that on letting this fluid escape the iris bulges forward, and may touch the cornea, and on compressing the abdomen the vessels burst, and the blood comes into the anterior chamber. No such bulging or haemorrhage can be brought about by squeezing the belly when the eye is intact.

Martin Flaek and I also showed that when one of the venae vorticae was opened, and the venous outflow from it was observed, while the pressure in the eyeball was raised by forcing normal saline into the aqueous chamber, the outflow of venous blood did not cease until the pressure in the carotid artery was just overtopped; this indicated that the capillary and venous pressures rise together and equally with the fluid pressure within the eyeball just as they do within the cerebro-spinal cavity. The contents of the eyeball are confined by unyielding membranes, and the intraocular pressure is ruled by the secretory action of the cells of the ciliary processes. Just as in the case of the brain if the cells secrete more fluid, there is less room for blood, the veins narrow and the capillary venous pressure rises. Suppose the pressure within the blood vessels rises, this increase of pressure is instantly transmitted to and balanced by the aqueous; both in the brain and the eye the pulse helps to keep up the outflow of venous blood and fluid, cerebro-spinal or aqueous.

Abraiding the skin, no less than opening the eyeball or skull cavity, removes the balancing counter-pressure of the tissue fluid enclosed by resistant membranes, and allows plasma to escape through the capillaries, which are no longer supported. The tissue cells and capillary walls, too, are damaged by exposure, and the transudation of fluid thus enhanced.

While in the living kidney, confined by its capsule, the pressure of the tissue fluid and secretion balances the capillary pressure; in the dead kidney, on the other hand, water driven through the renal vessels may filter out into the pelvis of the kidney.

A sharp distinction must be drawn between the living conditions and those in a wound or in an organ of a dead animal.

In the case of a salivary gland, it is known that on stimulating the chorda tympani nerve the pressure of the saliva, when its escape is obstructed, rises greatly above that in the carotid artery. Flaek and I found that the outflow from the salivary vein was not obstructed under these conditions; in fact the outflow might be rapid, while the gland became tense and swollen. There is a strong membrana propria which confines the secretory cells of each alveolus and limits its expansion, acting like the leather case of a football or the pericardium of the heart. Each lobule and lobe and the whole gland is surrounded with membranes limiting expansion. When the secretion is obstructed the alveoli swell, the lobules and lobes swell, and the whole gland swells until limited by the membranes, and the veins within the gland are narrowed while the arteries dilate owing to the influence of the vasodilator nerves, and the circulatory pressure is thus raised until arterioles, capillaries and veins approximate towards a rigid system at arterial pressure with a fast rate of flow.

In the sweat glands the structure is similar; the same high secretory pressure can be produced. In the kidney there are figured membranae propriae enclosing secretory cells of both renal capsules and tubules, but they are less well defined. The secretory pressure does not rise up to the arterial pressure.

Direct Measurement of Capillary Pressure.

Now let us turn to direct measurement of capillary pressure. Roy and Graham Brown used a small brass cylinder closed at one end by glass and at the other by a cup-shaped piece of transparent peritoneal membrane. A tube entered this little chamber, by means of which the pressure could be raised within it, a manometer being attached to indicate the pressure. With the peritoneal membrane in the domed-up position, the web of a frog's foot or other transparent tissues can be brought in contact so as to flatten down the dome somewhat. The web is then covered by a thick glass cover-slip attached to a holder. The chamber is placed beneath the low power objective of a microscope, and the capillary circulation observed. The pressure is then raised in the chamber so that the web is compressed between the membrane and the glass cover-slip, and the pressure is found which just obstructs the flow. In the case of man a similar apparatus inverted has been applied to the skin just behind the finger nail, and strong direct illumination used. A drop of castor oil is placed upon the finger before the application of the membrane, and the capillaries can then be seen in the papillae of the skin. Measurements of this kind have been made by a considerable number of observers, and give high values such as 20 to 40 mm. Hg.

Instead of microscopically observing the capillaries of man in the way just described, another method has been used—namely, that of finding out the pressure which just suffices to blanch a small area of the skin, as seen by the naked eye. To blanch the skin, 55 to 75 mm. Hg are required according to some observers, but the average generally given is 35 to 45 mm. Hg.

Basler has compared the colour of the compressed finger with another placed beside it, and taking the least change of colour as the index has found a much lower pressure than other observers—namely, 5 to 8 mm. Hg. He has also used a very ingenious method of making a small cut in the finger and inserting the finger in a tube connected with a manometer and finding to what pressure the escape of blood raised the manometer. Here again he finds the same low pressure. Now it is quite clear that in cutting the finger one probably would not only cut capillaries but might wound an arteriole, and the pressure might, therefore, indicate not capillary pressure, but that of the arteriole.

The arterioles in their end branches consist of endothelial cells and circularly arranged muscle cells. As they branch into capillaries the muscle cells cease, and the capillaries have an endothelial lining only. When the capillaries join together to form the venules, the endothelial lining first becomes coated with connective tissue fibrils, and then further on muscle cells are added. It seems very unlikely that there should be any great difference of pressure between the venous end and the arterial end of the capillaries. We know that the venous pressure is very small—for example, in a number of observations made by Bayliss and Starling on anaesthetized dogs while the pressure in the aorta was 81 to 125 mm. Hg, that in the vena cava was from 2 to 5 mm. Hg, and the pressure in the portal vein 5 to 8 mm. Hg. If in the upper arm the pressure is measured which just hinders the outflow from the lower, the arm being placed horizontally at heart level, it is found to be from 1 to 5 mm. Hg (L. Franks, Elpers).

The method used by Roy and Brown, and the method of blanching the skin first used by v. Kries, are methods which stop the flow of blood in the capillaries and arterioles, but obviously, if the flow of blood is stopped, the pressure rises to that within the arteries which feed these vessels. What has been measured then has not been capillary pressure but the pressure in the small arteries.

Krogh, who has made a great many observations of interest recently on the contractility of capillaries, says that mechanical excitation causes a contracted and closed capillary in the frog's tongue to dilate at the venous end first and the blood to advance from the venous end until finally the capillary dilates up to its connexion with the arteriole, when the current is suddenly reversed. Krogh finds then that the venous pressure is enough to fill the capillary, and overcome the resistance to flow within it, and the venous pressure is agreed to be only a very few millimetres of mercury.

I have examined the capillary pressure, using a modified

form of the Roy and Brown apparatus, kindly made for me by Dr. E. Schuster—

1. In the tadpole's tail.
2. In the toad's lung, tongue, mesentery, and bladder.
3. In the frog's lung, tongue, mesentery, web, bladder, and kidney.
4. In the newt's lung and mesentery.
5. In the grass snake's lung, mesentery, and kidney.
6. In the mouse's ear, mesentery, and abdominal muscular wall.
7. In the cat's mesentery and muscle.

To determine the pressure correctly the transparent membrane covering the compression chamber must be tied on loosely, as Roy and Brown direct, so that when blown up it forms a dome over which the web or other organ is spread; the threads attached to the toes in the case of the web, for example, are carried to pins, and the leg arranged so that the flow of blood is free and unobstructed. The glass against which the web is compressed is lowered until it touches the web, the top of the dome being thereby slightly flattened. The web is compressed between the flattened part of the membrane and the glass. Care must be taken to secure that the toes are not pressed by the glass cover against the metal rim of the pressure chamber, and that pressure is not spent in merely expanding the membrane.

Capillary pressure I take to be that pressure which just begins to lessen the velocity of flow in those capillaries wherein the flow is slowest. These naturally first undergo compression, the blood taking the pathway of least resistance through other capillaries. If the compression be gradually increased the flow is slowed, then stopped in more and more of the capillaries until it continues only through the most direct pathways connecting the arterioles with the venules wherein the velocity was greatest to start with. With further increased compression the flow of blood becomes pulsatile not only in the arterioles but in these capillaries and even in the venules, the compression being sufficient to stop the flow in diastole, but not in systole. Finally the blood is expressed out of the capillaries and veins, and the pulse is seen swinging the corpuscles to and fro in the arterioles, but not translating them onwards. The pressure required just to produce this effect is the systolic pressure in the arterioles supplying the compressed part.

All those phenomena which take place on the application of pressure to the arm by means of the cuff of the sphygmomanometer can thus be observed and taught to the student. The diastolic pressure can be measured in the frog's web just as well as the systolic pressure. Diastolic pressure is that which just arrests the onward flow of the corpuscles in diastole; to give an example, in a frog's web diastolic pressure was 17 mm. Hg and systolic pressure 26 mm. Hg.

The pressure required just to modify the capillary flow in the outer part of the tadpole's tail or at the edge of a frog's web is from 1 to 3 mm. Hg. There are some capillaries which require a higher pressure than this—for example, 5 to 8 mm. Hg—such as the capillaries in the papillae of the frog's tongue, or in the glomeruli of the kidney of the frog. Glomeruli may be observed with the blood corpuscles running through the afferent vessel, spinning round the network of capillaries and out by the efferent vessel—the whole giving a most striking picture. The following is the technique which was briefly described in the BRITISH MEDICAL JOURNAL of April 9th, 1921, p. 526:

The frog is put under urethane, an injection under the skin of the back of about 0.5 c.cm. of a 20 per cent. solution being given. The animal chosen is a rather small active one, not a female full of spawn. It is fixed on its side by pins through lip and ankle-joints; a lumbar incision is made through the skin and abdominal wall and the ileum on that side is removed. All haemorrhage is stopped by means of a cautery heated to a dull heat. The external edge of the kidney on which runs the renal portal vein is picked up in the forceps about the middle of the kidney and a ligature tied on at this point. The animal is then arranged belly upwards at the side of the Roy and Brown apparatus, and by a very gentle traction on the thread the kidney is drawn over the peritoneal membrane and the glass cover brought down upon it. The manipulation of the body and the traction on the thread must be so carried out as to expose the outer edge of the kidney to the light, when brought under the microscope, without stopping the circulation in the renal arteries. It is along this edge that the glomeruli may be found.

On examining the preparation the whole surface of the kidney is seen pervaded with wide venules and their capillary branches coming from the renal portal vein, through which the blood is flowing in slow and most ample streams. On putting on a pressure of 2 to 3 mm. Hg the blood is squeezed out of these veins, and glomeruli may then come clearly into view and exhibit the arterial blood coursing through them. I found a pressure of some 4 to 8 mm. Hg definitely slowed the flow in the glomeruli, while it took some 25 mm. Hg to stop the flow in the renal arteries. There is nothing extraordinary about the behaviour of the glomerular capillary network; it resembles that of other capillaries; the flow in the afferent and efferent vessels is stopped by the same pressure. I found it took very little pressure to drive the corpuscles out of the glomerulus when the circulation had stopped. I have seen the flow reverse under pressure before the glomeruli empty.

I find that a pressure of 2 to 5 mm. Hg momentarily applied checks the flow of corpuscles in the arterioles of the frog's web, etc., while it takes some 25 mm. Hg to stop the flow altogether. In the chief capillary branches, where the velocity of flow is rapid, the same pressure momentarily checks the flow, and at the same time as in the arteriole, but in the case of the venules the flow may be accelerated during and retarded momentarily after such an application of compression. The acceleration is due to the expression of blood from the capillaries, the retardation to the capillaries filling again. The pressure which momentarily checks the flow in the arteriole is, I take it, a measure of the pressure of the blood against the wall of the vessels. It closely approximates to that pressure which, when continuously applied, retards the flow in those capillaries with the slowest rate of flow. If the compression is maintained the pressure, of course, banks up behind it to that of the artery which feeds the obstructed arteriole. As the water manometer, owing to its inertia, does not fully record the value of the momentary compression, I have also used an air manometer with a xylol index, graduating this against the water manometer.

The conclusion then is reached that the pressure in the arteriole with unobstructed rapid flow is 2 to 5 mm. Hg, and that the fall of pressure from arteriole to venule is a very slight one. The flow in the venules is affected by a pressure of 1-2 mm. Hg.

The observations I have made on the mouse and cat show that the pressure in the capillaries and arterioles is no higher in the warm than in the cold-blooded animal. The assumption which has been made that the capillary pressure is some 30 mm. Hg, and the hypotheses as to the transudation of lymph, urine, etc., based on that assumption, appear then to be untenable.

Proof that the resistance in the capillaries is very slight is afforded by the following experiments: If the flow in the frog's web or tongue is stopped by a ligature placed round the thigh, we find, on exploring the field, one or more of the vessels, an arteriole, say, connecting some capillary with a venule, in which the flow continues for some minutes at a speed which is scarcely less than the normal speed in the capillaries. I have seen such a flow in the capillaries of the frog's web on placing it under the microscope forty minutes after cutting off the leg. The application of warm water to the web may restart such a flow when arrested. The flow may reverse, and this is against its being caused by contraction of the arteries. Again, when the web of the excised leg is compressed in the Roy and Brown apparatus a momentary pressure of 2 mm. Hg will cause the corpuscles to rush along the capillaries and venules no less rapidly than in the normal flow.

To try and arrive at a juster measure of the pressure in the capillaries in man my co-worker, Dr. James McQueen, designed the following method:

Warm water from a jet fed from a reservoir kept at constant pressure head is played on the skin below the nail or on the skin covering the distal end of the metacarpal bone of the thumb, the jet having a 2 to 2.5 mm. bore diameter. If the pressure be sufficiently high, the area impinged on is rendered white, and when the jet is moved a red blush of returning blood can be seen. To determine the pressure which just suffices to produce blanching, the jet is now turned so as to throw its column of fluid into the air alongside a meter scale; the distance of the upward throw of water is obviously the pressure of impact on the thumb in centimetres of water.

When readings of pressure are taken by this method with the arm held at heart level they do not materially

differ from the readings of pressure obtained by v. Kries and others. But, be it noted, as the flow is stopped in the blanched part the readings are of arteriole not capillary pressure. Moreover, there remains to be considered the considerable resistance of the convex horny layer of skin to compression. There are also the resistance of the vascular wall to compression, the friction of the blood as it is expelled from the compressed area, the resistance of the lymph or tissue fluid surrounding the capillaries. These resistances are very small, as is shown by the fact that a pressure of 1 cm. of water applied to the membrane of the Roy and Graham Brown apparatus is sufficient to drive the corpuscles quickly along the vessels of the web wherein the circulation has been arrested. Their sum can be accurately estimated provided the blood pressure in the compressed area can be reduced to zero. Then the pressure taken to blanch the area is a measure of the resistance factors. To effect this the hand is raised above the heart level, at a certain point the veins collapse, because the venous pressure has been overtopped by gravity, and is, in the hand, zero. If the brachial artery is now occluded, the arterial pressure entering the hand is, in its turn, reduced to zero. Accordingly the capillary pressure becomes zero. A tourniquet of rubber tubing can be used, or the cuff of the sphygmomanometer connected with a compressed air cylinder so as to secure a rapid application of pressure to the artery.

In order to keep enough blood in the capillaries to give a clear index, it is advisable to put a rubber band round the wrist before elevating the arm and compressing the artery, and then to remove this band. If the jet be projected on the thumb when the area has thus been brought to zero pressure, a measure of the pressure in centimetres of water required to blanch the area is now obtained. This pressure measurement—the measurement of resistance factors—has to be subtracted from the original measurement obtained when the normal conditions of pressure pertained in the arterioles. The diminished reading is now the actual arteriole pressure. To cite an example:

Subject E.—Hand at heart level. Pressure to blanch 2.5 mm. area=35 cm. water. Resistance measurement (after vascular area reduced to zero pressure)=24 cm. water. Difference=arteriole pressure=11 cm. water. This method gave us an arteriole pressure of about 10 mm. Hg.

In the case of the bat's wing I found the main arterial branch in the second segment measured about 0.08 mm. in diameter, and the main arterioles about 0.015 mm., these coming off at right angles. When the bats are hibernating the pressure in the main branch is low, rising from some 20 mm. Hg to 50 mm. Hg as the bat becomes warm. When the systolic pressure in the main arterial branch is 50 mm. Hg that in the main arterioles is about 15 to 20 mm. Hg.

There is then a great drop of pressure on passing from the main arterial branch to the main arterioles. It is in these vessels that the great fall of arterial pressure takes place through resistance to rapid flow.

I now pass to the consideration of the contractility of the capillaries.

Effects of Arterial Contractility.

According to the general view the contractility of the arteries regulated by vasomotor nerves controls the flow of blood to each part, diverting greater streams to parts in action. But the contractility of the capillaries and venules is now an established fact, and the evidence seems to show that it has an important share in the local and general control of blood flow. Stricker (1865) noted on appropriate stimulation the constriction of the capillaries in the nictitating membrane of the frog, and ascribed it to turbulence of the endothelial cells, which form the capillaries. His observations have been confirmed by several, but no one has proved how the constriction is brought about.

The capillaries of the web dilate after the momentary touch of a brush dipped in chloroform, stasis being prevented by well washing with water. Inhibition of the heart had no effect on this dilatation, it was not brought about by blood pressure (Roy and Brown). A small drop of nicotine applied locally to the area vasculosa of the chick on the fourth day of incubation produced such dilatation that the rest of the area was almost emptied (Vulpia). Lewis and his co-workers found that in the arm, with the artery blocked by the cuff of the sphygmo-

manometer, a scratch on the skin with a blunt instrument produced the well-known white and red lines. In such case they must be ascribed to capillary contraction and dilatation. Local injection of adrenin also blanched the skin when the arterial flow had been stopped.

Temporary anaemia produced by ligation or compression of an artery dilates the capillaries. Almroth Wright attributes this to the production of acid through anaemia. We know that oxygen want leads to the appearance of lactic acid in muscles, and a drop of acid dilates the capillaries. On the other hand, Krogh attributes the dilatation to some unknown property of the blood, for he finds it takes place when the frog's tongue is exposed to oxygen. The capillaries are conceived by him as spontaneously contracting and dilating, and thus alternating the blood supply to the tissues, dilatation following on the anaemia produced by contraction.

Krogh finds that local mechanical, or thermal, stimulation, or the application of minute drops of weak acid, cocaine, and adrenaline produce local dilatation of both arterioles and capillaries. The effect spreads to a wider area than that stimulated. A drop of urethane (20 per cent.) dilates the capillaries and not the arterioles. The spread of the reaction due to stimulation is abolished by cocaine, and not affected by mere section of the nerves, but disappears when the nerves have degenerated, being then sharply limited to the point excited. The reactions are considered to be due to a spread of excitation along sensory nerve fibres to that antidromic vaso-dilator effect discovered by Bayliss in the posterior root axons. The contraction of capillaries may reduce their diameter by more than half and their sectional area fivefold. Dilatation occupies several seconds, contraction one to three seconds. A single stimulus is ineffectual; the galvanic current is better, and mechanical stimulus most effectual. A vast number of capillaries are at any one time not open, as may be seen by the growing flush and swelling of the hand on occluding the veins of the arm. The aching sensation which arises from congestion keeps one naturally restless, and every movement helps onward the flow.

Krogh finds an enormous increase in the number of open capillaries in muscle during activity. In the mammal he used intravenous injections of Indian ink to render the capillaries visible. He estimated that in the guinea-pig the total surface area of the capillaries per cubic centimetre of muscle was 3 to 32 sq. cm. at rest and 360 to 750 in activity; in the frog 1 to 12 sq. cm. at rest and 70 when active. The oxygen supply to the active muscle is thus kept ample.

I find a very instructive preparation of the abdominal muscular wall of the mouse (under urethane) can be made by an incision through the median line of the lower half of the abdomen and another carried laterally outwards from the mid-point, the skin being reflected, the triangular flap of muscles with the blood vessels entering from below is brought on to the membrane of the Roy and Brown apparatus. In such preparations all the capillaries appear filled, perhaps owing to exposure or to the fact that the muscle is always in respiratory action.

Venous Contractility.

In the hibernating bat's wing most of the capillaries are empty, and the veins contract in such period as to help the feeble flow. There may be, and probably are, contractions of all veins which further flow. We know that muscular contractions and change of posture greatly contribute to return of the venous blood to the heart. Thus Burton Opitz on stimulation of the sciatic nerve found the outflow from the femoral increased three to four times above the resting value during the shortening of the muscles, but it was diminished to about a third during the height of tetanus.

Hooker isolated the sigmoidal area of the large gut of the dog, and leaving the artery open connected the vein with a manometer. Excitation of the nerve supply from the inferior mesenteric ganglia increased the venous pressure by 5 mm Hg, asphyxia increased it by 3½ mm. Hg. Although the lumen of the gut did not show this rise of pressure when closed and connected to a manometer, I believe that the contraction of the tissues caused the rise.

Hooker also finds that after death from ether the capillaries first contract and empty, then dilate and fill, and finally contract and empty when rigor comes on. This does not happen in the cat in a state of shock—for example, in one poisoned by histamine,

The arteries of the ear in such a cat contract on stimulation of the nerves or on injecting adrenin, but not the dilated veins and capillaries.

Shock.

The work of Dale and his co-workers indicates that shock produced by histamine has its origin in primary failure of the peripheral circulation. All the capillaries open and venules dilate at once, and there is increased passage of fluid from the blood into the tissues, and so the circulation fails while the heart is beating efficiently. While Dale injected histamine, I watched the venules dilate in the mesentery and the flow slow down and almost become arrested in these and in the capillaries, but have not so far been able to see the opening up of closed capillaries, probably because the capillaries are already dilated by exposure. Histamine is formed by decarboxylation of the amino-acid histidine, which is derived from proteins, and it is conceivable that such substances are produced in trauma. Herein we have an explanation of shock differing from that of acid causation put forward by Albroth Wright.

Be it noted, histamine acts in the cat anaesthetized by ether, but not in the normal cat or one anaesthetized by nitrous oxide and oxygen. The last is by far the best anaesthetic for preventing shock, and as P. Bert proved forty years ago, and Dale and I have confirmed recently, may be given with ease and safety and efficiency of depth in a pressure chamber at +7 lb. pressure. An operating chamber can easily be constructed so that the patient, surgeon, and anaesthetist are all within the chamber at slightly increased atmospheric pressure. The effect of inhaling gas and oxygen, given in the usual way from a bag in such a chamber, is an increase of partial pressure, or concentration, of both in the blood, and deep anaesthesia with no want of oxygen.

Effects of Oxygen Inhalation.

The beneficial action of oxygen inhalation in relieving oedema and chronic ulcers has recently been made evident to me by the use of an oxygen tent bed, constructed for me by Messrs. Siebe, Gorman, Ltd. This tent bed allows 30 to 40 per cent. oxygen to be breathed in comfort for days, with intermissions for meals. The oedema disappears, the part becomes warm and of good colour, the granulations healthy, the edges of the ulcer flatten, and the skin hastens to spread over the ulcer.

The question arises as to how the capillaries contract and dilate. It is generally assumed, but unproven, that it is due to changes in the swelling of the endothelial cells of the capillary wall. I suggest that it is due to the tissue cells outside the capillaries; these, by swelling or shrinking, control their own blood supply. By increase of waste products with higher osmotic pressure they take up fluid from the blood in the capillaries and swell, and so contract the capillaries. By chemical-physical changes resulting from the taking up of fluid from the blood the osmotic pressure falls, and the fluid passes back into the blood or lymphatic channels.

I have pointed out what happens in the salivary gland on excitation of the chorda tympani, and how the membranae propriae and other membranes confine tissue expansion so that the capillaries and veins may be narrowed but not occluded. I do not believe fluid is transuded out by the force of the heart producing a filtering pressure, but that the heart just succeeds in maintaining a flow in the capillaries with no excess of pressure for other purposes, and the tissues by inhibition swell or shrink, taking or giving up fluid.

Charles Bolton, narrowing the inferior vena cava to one-third by a rubber ring, has shown that oedema results in dogs, not when the temporary small rise of venous pressure occurs at first, but later, when the venous pressure has returned to normal. Oedema is due to ill nutrition of the tissues, not to increased vascular pressure and filtration, whether it arise from poor flow and want of oxygen in heart disease or from a chemical poison in kidney disease, or from a bacterial toxin.

The swelling of the tissues in oedema, by pressing upon the venules, raises the capillary pressure.

I have measured the pressure in a case of hydrocephalus with the infant lying horizontal. It was nearly 15 mm. Hg. On raising the head from the pillow the pressure

rose owing to my hands squeezing the head which was a bag of fluid. The capillary venous pressure in the pial vessels must have risen *pari passu*, there is no mechanism for shielding them from the pressure of the fluid. I moreover found, on drawing off the fluid, that the pressure sank to 0 that is, to atmospheric pressure—and the soft wall of the skull by its weight sagged in. So it remained for hours, until the fluid was re-secreted.

In a case of oedema of the leg, with the patient sitting propped up, the pressure of the fluid equalled about 40 mm. Hg; here again the pressure rose on lifting the leg up, owing to squeezing by the hands, and the capillary venous pressure must have risen *pari passu*, and kept as it is normally, the least bit above the tissue fluid pressure, so as to maintain the venous outflow.

In inflammation the products of tissues damaged by bacterial toxins cause dilatation of arteries and swelling of tissues. The swollen tissues, confined by the membranes, press upon and narrow the veins and capillaries. The blood pressure rises, and we have a more rigid system with fast flow, redness, swelling, and a throbbing pulse in the part. The tissues may swell so that stasis is produced; the surgeon's knife then relieves the swollen, tense condition, and allows lymph with its immunizing powers to escape. Bier's bandages obstructing venous flow may cause increased outflow of lymph, not by transudation under pressure, for capillary pressure is balanced by tissue fluid pressure, but by increased imbibition of tissue cells due to oxygen want. The salt solution treatment of wounds devised by Albroth Wright pulls fluid out in increased amount, and washes the wounds just as the breathing of cool air, with its low water vapour content, by evaporating moisture from the respiratory membrane, draws abundant lymph from the blood and keeps this clean and healthy.

Krogh finds that, after putting in a drop of 20 per cent. urethane on the capillary field and injecting neutral red intravenously, the dye passes through the dilated capillaries and stains the bordering tissue, the stain fading away from the capillary. This he ascribes to increased permeability. It may equally well be due to increased force of inhibition exerted by the damaged tissue cells. The escape of white blood cells during stasis and of red cells on severe injury shows a pathological permeation of the capillary wall: but normally the tissue cell, not the capillary pressure, governs the passage of fluid.

References to literature are fully given by Tigerstedt, *Ergebnisse der Physiol.*, 1920, 18, and Hooker, *Amer. Physiol. Review*, 1921, 1, Part I. See also Krogh, *Journ. Physiol.*, 1920, 53, 26; Leonard Hill, *Proc. Physiol. Soc.*, *Journ. Physiol.*, 1920-21, 54; Leonard Hill and J. McQueen, *Brit. Journ. Exper. Path.*, 1921, 2, 1.

DUAL RADIOTHERAPY IN MALIGNANT DISEASE.

BY

S. GILBERT SCOTT, M.R.C.S., L.R.C.P.,

DIRECTOR OF THE RADIOLOGICAL DEPARTMENT, LONDON HOSPITAL.

X RAYS and radium are undoubtedly powerful therapeutic agents. But, since the technique required to obtain their complete beneficial results has not as yet been mastered, we are at present unable to make full use of them. Consequently most of our failures must be attributed to the uncertainty of our technique rather than to the agents themselves.

Physicists have given us much help in solving some of the problems connected with γ rays and radium. But until they can give us not only an accurate means of measuring dosage to pathological cells lying below the surface of the skin, but also indications of the conditions and dose required to produce a full lethal effect on these cells, our results are bound to be erratic. At present results depend partly on luck—that is to say, on whether the particular dose administered happens to be the most effective one—and partly on the practical experience of the radiologist, which enables him to gauge this with a certain amount of accuracy. It should, indeed, be possible to administer γ rays and radium radiations as accurately as drugs. It should equally be possible to have some idea of the prescription required for the ease in hand.

There are, perhaps, no therapeutic agents affecting such a variety of diseases, or from which more remarkable

results can be obtained in many cases otherwise hopeless. The work carried out by the *x*-ray treatment department of the London Hospital in the course of the last ten years bears out this statement. Over 11,000 new cases have been treated, averaging 5,000 attendances a year. This total includes 115 different diseases, ranging from deep-seated and malignant tumours to conditions so superficial as warts and corns. It is clear that control of dosage is essential in the treatment of such widely separated diseases.

Out of the total given above, 1,500 were cases of mammary carcinoma, some requiring prophylactic treatment, others being recurrent or inoperable. Carcinoma of the breast being the largest class of cancer cases, I endeavoured to find out and classify the results of *x*-ray treatment in the hope of improving our methods. The tracing of hospital patients was impracticable. Statistics are apt to be deceptive. But in the case of patients who were traced, metastases in the thorax accounted for a large percentage of deaths, although the superficial recurrences had been controlled. Was it not possible to control these deep metastases in the same way as the superficial? Clearly, any successful method must fulfil two conditions: (1) It should be possible to administer a dose lethal to pathological cells lying at various depths and in unknown positions; (2) the radiated area should be large. The importance of the second factor is emphasized in a valuable paper on the "The Spread of Breast Cancer," by W. Sampson Handley, in the *Archives of Radiology and Electrotherapy* (October, 1920).

In the hope of fulfilling these two conditions, I devised the dual method of radiotherapy which has been installed in temporary quarters at the London Hospital. Although designed for the treatment of carcinoma of the breast and thoracic tumours, it can be used for many deep-seated conditions, such as abdominal tumours, splenic cases, and it may, I believe, prove of some value in the treatment of pulmonary tuberculosis.

Rationale of Treatment.

The complex question of dosage cannot be discussed here, but I have for some years based my deep therapy on the following principles: (1) Full cell absorption; (2) production of a large number of heterogeneous rays; (3) a filter only thick enough to protect the skin and to cut out rays of little or no therapeutic value. These were suggested by facts supplied by physicists and by gleanings from my personal experience. Although I cannot here go into further details, the results in the more superficial conditions have been up to the present so satisfactory that an elaboration on the same lines, such as with the dual method, seemed justified. Any new scheme for deep therapy should be founded on a logical basis. It must be admitted that our knowledge of the actual influence of *x* rays on the living cells is meagre; but I think it is sufficient to indicate the lines that should be followed, even though these may have to be altered as our knowledge increases. I do not think the full therapeutic value will be obtained by endeavouring to produce *x* rays with the penetration of radium at the expense of maximum cell absorption. I suggest that there is some unknown factor in radium radiations which, apart from their high degree of penetration, may account for their therapeutic effect. The reports of the Radium Institute show that the therapeutic results of radium radiations are equal to those of *x* rays properly administered, their chief value being in cases where the disease is inaccessible to the latter, whilst their disadvantage lies in the limited field of radiation.

Technique.

The shortcomings of our present methods are these:

1. The dose administered to the deep-seated and scattered pathological cells is too small.
2. The area treated is much too limited.

The dual method for deep therapy, of which I have found no mention in the literature, consists of two separate installations, of which one operates a tube in front, the other a tube at the back of the patient, who is in the sitting position, both tubes running simultaneously. After the first full dose has been administered the direction is changed, so that the radiation is now from side to side, the arms being forward and raised. In this way the

deepest parts of the body are subjected to radiations from the four points of the compass, and the resulting cell absorption must be very much greater than with our present methods, although the more superficial, or skin dose, controlling superficial recurrences, remains the same.

By this method, which may be described as a combined cross-fire, the deficiencies of current methods, referred to above, are avoided; that is to say, (1) by working both tubes at the same time from both sides of the body a larger dose is administered to the deeper pathological cells; (2) a very large area is covered.

It is doubtful whether any additional therapeutic effect is to be expected from the coincidence of the rays in the deeper tissues. At any rate, malignant cells in the tissues, lymph channels or blood stream, must certainly come under the influence of the radiations.

The radiation of a large area did not present much difficulty. It merely entailed the manufacture of a protective shield or tube-box with a large opening. I prefer a lead glass shield, but as I was unable to obtain one with an opening large enough for my purpose, I utilized the standard one reversed—that is to say, the smaller opening, blocked by protective material, not only holds the shield in position, but admits the air-blast, directing it to the back of the tube. The larger aperture now faces the patient, giving a very large radiation field, including, at a reasonable distance, practically the whole trunk, axillae and supraclavicular fossae.

I consider it important that the maximum dose the patient can tolerate should be administered at the first and at every subsequent sitting. If this is not done, there is a possibility of the pathological cells being encouraged or stimulated to assume defensive measures against the destructive effect of the radiations. We all know that some kind of acquired immunity, not to be confused with stimulation, may occur. Cases that respond well at first may quite suddenly cease to do so if the treatment is prolonged and the dosage too light.

To put it briefly therefore: "Always hit hard; do not continue treatment once you have achieved your object."

Blood counts are at present carried out in all patients immediately before and after exposure, and at varying intervals subsequently, with a view to ascertaining the maximum dose they can tolerate. But, when once this is established, these frequent blood counts will probably be unnecessary—at any rate in cases of mammary carcinoma. In all cases of cancer the thorax is carefully examined radiologically before treatment, and a plate taken as a record.

We cannot as yet decide definitely how frequent the treatment should be; this must, to a certain extent, depend on the blood changes and other symptoms, the significance of which is still debatable. At first, patients were treated once a week, receiving 20 X skin dose through 3 mm. of aluminium at each of the four areas—the front, back and two sides, giving a total of 80 X at each sitting. Six of these would have completed the first series of 480 X, but it was found that only a few patients could tolerate the full 80 X dose. The occurrence of nausea and vomiting within a few hours of treatment (sometimes lasting as long as three days) demonstrates, I think, the fact that tolerance to *x* rays has been reached and is limited in different patients. I believe, however, that by working up to the maximum gradually, secondary symptoms may be avoided. These after-effects may not necessarily be the results of *x* rays: ozone and nitrous fumes may cause the sickness. The whole matter is being investigated.

Treatment is now administered weekly: anteriorly and posteriorly the first week, the second week from both sides, the total dose being 40 X through 3 mm. of aluminium in each week. Although many tolerate it, there are some who cannot stand even this dose.

DO dosage.

Registration of Dosage.

Accurate measurement of the dose absorbed by the pathological cells composing even a single tumour is practically impossible. At present only a very rough calculation can be made, and even this is dependent on several unknown factors. The difficulty is still greater when we are endeavouring to irradiate a number of cells scattered about in the body at unknown depths and in unknown positions. The best we can do is to measure the maximum

skin dose under certain known conditions and give as large a dose of heterogeneous rays as possible. The calculation of the skin dose used in the treatment of tinea is simple and accurate, but difficulties arise when a filter is inserted. We have the Sabouraud pastille, the Kienbock strip, the Holzknacht strip, and many others by which the dose can be gauged, but most of these are intended for use without a filter. We are waiting for a simple practical unit for filtered rays.

For want of a better I have, for many years, used the Sabouraud pastille on the skin as my unit, Kienbock's strip not being very practical, as an overdose or underdose may easily be given, usually too late to remedy the error. The time factor with a Coolidge tube is fairly accurate, but even here each tube must be tested periodically by some method or other. It is better to take the reading on the skin itself, as the distance of the tube and the thickness of the filter can then be practically disregarded, although this process involves the establishment of a new unit. The main difficulty when using a Sabouraud pastille on the skin is the reading of the slight tint alteration that takes place, but this may be overcome by the use of a tintometer.

I have found from experience that the effect on the skin of an erythema dose through a filter was not the same as without a filter, a fact which, I believe, agrees with the expectations of physicists. Realizing this, would it be possible to fix a unit which would give us the danger dose through a filter? The method I adopted some years ago to gauge roughly the maximum skin dose with a filter, when treating deep-seated tumours, is as follows: A Sabouraud pastille is placed on the skin; when this registers a quarter B tint the skin has received a 10 X dose, irrespective of the distance of the tube or of the thickness of the filter. This was taken as the minimum dose, not as the erythema dose, the maximum which I have applied being a 20 X dose, again measured on the skin through 3 mm. of aluminium. The pastille in this case will read $\frac{1}{2}$ B tint. The $\frac{1}{2}$ B tint and the $\frac{1}{2}$ B dose must not be confused; they are entirely different. Penetration should not be below 9.5 Wehnelt. Caution is required by the operator in using these large doses; they should be worked up to gradually. The margin of error being small, a certain amount of proficiency in the use of the apparatus and in the reading of the pastille changes is essential.

I have given this 20 X dose through 3 mm. of aluminium as often as twice a week in desperate cases with no resulting skin changes beyond deep pigmentation. Such possibilities as late reactions must be risked when the patient's life is at stake.

Possible Dangers.

1. *Blood*.—Massive doses are said to lead to definite blood changes, the details of which cannot be gone into here. With the dual radiotherapy, not only is the total dose large owing to the extensive area of the body subjected to radiations, but the heart, when thoracic conditions are being treated, is being radiated from all sides. I believe, however, that any blood changes that occur are caused by the direct action of the rays on the blood-making tissues, such as the spleen and bone marrow, rather than on the blood corpuscles. So far no blood changes have been found.

2. *Intestines*.—Various organs are said to be influenced by radiations, amongst them the intestines. As the dual method has not yet been applied to abdominal cases this point cannot be settled. A careful watch should be kept on all patients under treatment for indications of possible damage to organs in the field of radiation. Any undesirable effect should be rectified by modification of dosage and frequency of treatment.

Results.

The first patient was treated by the dual method only on February 24th, 1921, and some time must therefore elapse before any reliable data can be expected where an effort is being made to prevent metastases, but in those cases in which the primary lesion has been treated, such as an intrathoracic growth they appear to respond very much more rapidly than with the localized method used previously.

It must always be remembered that the time is possibly approaching when the cure may prove worse than the

disease. In our efforts to destroy malignant cells we may destroy far more than we intended.

The *secondary phenomena* so far noted are of some interest. Few can tolerate the full 80 X dose, nausea and vomiting, lasting from several hours to three days, appearing shortly after treatment. If, however, the dose is halved—two opposite areas only being treated instead of four—the patients may experience a feeling of well-being, which one patient aptly compared to the effect of a glass of champagne. In one case, that of a large intrathoracic growth (the patient was a doctor), the secondary symptoms—nausea and vomiting—were very marked after even the first 40 X dose, yet others experienced no ill effects whatever, even after the full 80 X dose. These secondary phenomena are somewhat puzzling and are being investigated, as other causes besides the direct action of x rays may be responsible.

I have given but a rough description of the method, hoping that others may work on the same lines, and that at some future time interesting comparisons and conclusions may be made.

Radiologists appear to have divided themselves into two schools—those who endeavour to attain *maximum cell absorption* and those who pin their faith on *excessive penetration* at the expense of absorption. The dual method follows the cell absorption line of technique.

FURTHER REPORT ON THE TREATMENT OF SLEEPING SICKNESS.

BY

CLAUDE H. MARSHALL,

SENIOR MEDICAL OFFICER, UGANDA PROTECTORATE

AND

S. M. VASSALLO,

MEDICAL OFFICER, UGANDA PROTECTORATE.

In a previous report published in the *BRITISH MEDICAL JOURNAL* of May 22nd, 1920, p. 702, by one of us (C. H. M.), attention was drawn to the treatment of sleeping sickness by combined intravenous and intrathecal injections of organic arsenical preparations (neo-kharsivan). An epitome of twelve cases thus treated was also given.

Since then the number of cases treated and under observation has increased to over 50, and the conclusions we have drawn are that this treatment shows prospects of a possible cure for, at any rate, early cases of this protean disease.

The following is a summary of the technique of the treatment, given in detail in the report previously alluded to:

An intravenous injection of an organic compound of arsenic is given, and after a period varying from one to four hours a certain quantity of blood—usually 20 c.c.m.—is withdrawn. This is kept in a vessel, stood in cold water, until the serum separates completely from the formed elements of the blood. The separated serum is then injected into the cerebro-spinal cavity, an equal amount of cerebro-spinal fluid having been previously drawn off. This completes the treatment, and the patient is free to resume his normal life, subject to his reporting from time to time for re-examinations.

The principle of the treatment was based on the theory that the trypanosomes having once reached the cerebro-spinal canal were, after a certain time, immune to any medication via the blood stream; since we have adopted this routine procedure for sleeping sickness cases we have had striking examples of this fact.

The following are examples:

Case 10.

Karungaho, a man with large typical chains in the neck admitted to hospital on June 14th, 1920. Glaucl puncture showed numerous trypanosomes and filariae. On June 15th 0.6 gram neo-kharsivan was injected intravenously; on the 17th 12 c.c.m. of cerebro-spinal fluid were drawn off by lumbar puncture. The cerebro-spinal fluid on examination showed trypanosomes.

Case 11.

Wana, a man with large typical glands, was admitted on June 19th, 1920, glaucl puncture showed trypanosome infection. Neo-kharsivan 0.5 gram was administered intravenously on June 20th, and on the 25th when 12 c.c.m. of cerebro-spinal fluid were drawn off, prior to intrathecal medication, it was found to contain living trypanosomes.

The next case is, to our mind, more striking, and we think proves conclusively our theory.

Case 3A.

Asumani, a boy with typical enlarged glands on both sides of the neck from which trypanosomes could easily be recovered, was admitted on August 3rd, 1920. On August 5th he received 0.6 gram of neo-kharsivan, and as his home was far away he was kept in hospital. He was given no intraspinal treatment. Towards the end of October this boy reported difficulty in walking and general debility; on examination of his cerebro-spinal fluid living trypanosomes were found, while none were discoverable in the blood or in his cervical glands. His glands were again examined at the time of writing this report (December 24th, 1920), and still nothing could be found.

(It should be noted that in none of the above cases was there any chance of reinfection.)

While there is no doubt that in healthy individuals drugs administered intravenously may find their way into the cerebro-spinal fluid,¹ we are of opinion that the choroid plexus mainly and other structures concerned in the diffusion of the plasma and the cerebro-spinal fluid, become obliterated at a clinically early stage; the result is we have two foci of disease—the blood or lymphatic stream and the cerebro-spinal cavity—and to get rid of the disease it is necessary to attend to both these foci. That the permeability of the meninges is seriously affected at an early stage of the trypanosome infection is evidenced in the living by early lymphocytosis of the cerebro-spinal fluid, and in the dead by microscopical examination of the meninges, the latter being at times the only evidence of the disease; and when such nervous alterations have occurred, blood medication, however active, will fail to influence the course of the disease.

Many authorities are agreed that the administration of a dose of salvarsan, neo-salvarsan, or atoxyl is sufficient to sterilize the blood in a surprisingly short time; the patient is thus looked upon as temporarily cured, but within a variable period of time nervous symptoms appear, and the infection goes on unchecked, the patient eventually dying. Excluding reinfections, two theories have been put forward to account for this: (a) That there are resistant forms, and (b) that certain trypanosomes are protected from the action of the medicament by their position in the organism, for example, bone marrow, central nervous system.² While the possibility of the trypanosome in forming new races cannot be doubted, and is by some considered as unlimited,³ we are more inclined to think that the second theory is the more probable, from the arguments we have set forth.

It also appears very probable to us that, if we can obtain a case of trypanosomiasis in its early stages, one single dose of salvarsan or any other allied drug may be enough to cure once for all the patient from the infection, and this may account for those cases which have been recorded as cured, and in this category we are inclined to place two of our own cases (Case 14 and Case 28), who only received an intravenous injection, and who, up to now, are enjoying excellent health. These cases were originally kept as controls, and that is why they had no salvarsanized serum given them.

The detection of early cases is a difficult affair, except perhaps in Europeans where a history of having been bitten by a fly in a glossina-infested area, may be obtainable. Even then the assertion that the case is an early one is distinctly risky, as one cannot be sure of the presence or otherwise of the trypanosome in the cerebro-spinal fluid unless the latter is examined, and once this has been decided upon, as it should be, the salvarsanized serum can be given at the same time.

An injection into the thecal cavity, done with the usual antiseptic precautions, does not show any untoward symptoms or sequelae; we have noticed that the injection of salvarsanized serum is usually accompanied with a slight rise of temperature to 100° or 101° F., pains in the back along the spinal column—most marked in the region of the anus—vomiting, and slight diarrhoea. These symptoms disappear in a day or two, after which time the patient is discharged.

The course, therefore, of the trypanosome in the human body is, first, its passage into the blood, subsequently followed by glandular enlargement, usually in the cervical region; secondly, its passage into the central nervous system, where soon it produces lesions of the meninges, which shut it off from its parent in the blood. The curability or otherwise of the disease, therefore, depends to a great extent on how far the nervous lesions have advanced; if these are far advanced the infection ceases, so to say, to be trypanosomiasis and becomes a chronic

nervous disease, ending in death. There seems to be, though, an appreciable period of time between the passage of the trypanosomes in the cerebro-spinal fluid and the onset of nervous symptoms, and it is possible, we think, to greatly improve, and perhaps cure, the patient during this time; it is only when irremediable and irreparable damage has been done to the central nervous system that the case is hopeless.

From an analysis of cases thus treated (from these we exclude those which have been done during the last three months) it appears that the patients after the treatment start putting on weight, feel much better and are generally changed individuals. They are able to do physical work, not excluding porters' work, which, we might add, consists in the carrying of loads varying between 40 and 50 lb. for an average distance of about ten or fifteen miles. Another patient of ours, treated in April (Case 23), aged about 60, cycled in about thirty miles one morning for re-examination—a feat for him, as he stated he had been unable to ride a bicycle for at least a year before treatment.

Analysis of Cases of Sleeping Sickness treated with Neo-kharsivan, Atoxyl, or Plain Serum.

N = Neo-kharsivan; A = Atoxyl; S = Plain Serum.

Case No.	Sex.	Date of Treatment.	Drug.	No. of Re-examinations, with Date of Latest.	State of		
					Blood.	Glands.	C.S.F.
1	M.	1918. Sept. 26	N	1919. 1; Jan. 11			
2	F.	Sept. 20	N	1920. 5; Oct. 29	Neg.	None	Neg.
3	M.	Oct. 1	N	—	—	—	—
4	F.	1919. Jan 9	N	4; June 28	Neg.	None	Neg.
5	F.	July 11	N	1; Oct. 26	—	—	—
6	Dog	—	—	—	—	—	—
7	M.	June 1	N	5; Oct. 26	Neg.	None	Neg.
8	M.	Sept.	N	3; Nov. 28	Neg.	None	Neg.
9	M.	Sept. 26	N	1; Nov. 3	—	—	—
10	M.	Oct. 25	N	—	—	—	—
11	M.	Nov. 27	N	3; Oct. 23	Neg.	None	Neg.
12	M.	Nov. 27	N	3; Oct. 23	Neg.	None	Neg.
13	F.	Nov. 29	N	3; Nov. 3	Neg.	None	Neg.
14	M.	Nov. 29	N	3; Oct. 26	Neg.	1 gland; 2 punctures;	Neg.
15	M.	Dec. 2	N	3; Nov. 3	Neg.	None	Neg.
16	M.	1920. April 26	N	2; Oct. 26	Neg.	None	Neg.
17	M.	April 26	N	2; Oct. 26	Neg.	None	Neg.
18	F.	April 26	N	2; Oct. 28	Neg.	None	Neg.
19	F.	April 23	N	2; Nov. 3	Neg.	None	Neg.
20	M.	April 26	N	—	—	—	—
21	M.	April 27	N	—	—	—	—
22	F.	April 27	N	1; Nov. 3	Neg.	None	Neg.
23	M.	April 28	A	2; Oct. 26	Neg.	None	Neg.
24	M.	April 28	A	1; Nov. 3	Neg.	None	Neg.
25	M.	April 23	A	2; Oct. 26	Neg.	None	Neg.
26	M.	May 3	A	2; Oct. 26	Neg.	None	Neg.
27	M.	May 4	A	1; Oct. 26	Neg.	None	Neg.
28	M.	May 8	N	1; Nov. 3	Neg.	None	Neg.
29	M.	May 13	N	1; Nov. 3	Neg.	None	Neg.
30	M.	June 15	N	1; Nov. 3	Neg.	None	Neg.
31	M.	June 15	S	1; Nov. 3	Neg.	None	Neg.
32	F.	June 18	N	1; Nov. 3	Neg.	None	Neg.
33	M.	June 20	N	—	—	—	—
Under six months.							
31	M.	Sept. 5	S	No re-examinations to date.			
35	M.	Sept. 13	S				
36	M.	Sept. 14	N				
37	M.	Aug. 28	N				
38	M.	Aug. 17	N				
33	M.	Aug. 27	N				
40	M.	Oct. 4	A				
41	M.	Oct. 5	A				
42	M.	Oct. 6	A				
43	M.	—	—				
44	F.	Oct. 4	N	No re-examinations to date.			
45	M.	Sept. 29	S				
46	M.	Sept. 24	N				
47	M.	Nov. 15	A				
48	M.	Nov. 15	A				
49	M.	Nov. 15	A				
50	M.	Dec. 2	A				
51	M.	Dec. 2	A				
52	M.	Dec. 6	A				
53	M.	Dec. 6	A				
54	M.	Dec. 6	A				
55	M.	Dec. 6	A				
56	M.	Dec. 28	N				

Notes.—Case 1 died of sleeping sickness. Case 3 (the date of whose treatment is uncertain) disappeared; presumably dead. There are no records of Cases 5 and 9; 2 died of sleeping sickness. Case 6 (dog) was shot. Case 10 died of sleeping sickness. Case 33 died (CHCl₃ poisoning). Case 34 is under treatment; referred to in report. Case 42 died of pneumonia, October 25th, 1920. Case 43 died one day after admission; no treatment given. Case 46 was a European.

Duration of Cases up to December 31st, 1921, without any Symptoms or Microscopical Findings.

Case 2	27 months
" 4	Av. 24 "
" 7	Av. 18 "
" 8	Av. 15 "
" 9	Av. 15 "
" 10	14 "
Cases 11 to 15	13 "
" 16 to 25	8 "
" 26 to 29	7 "
" 30 to 33	6 "

Cases in which the Cerebro-spinal Fluid was Positive.

Case 7.	Case 39.
" 10 (since dead of sleeping sickness).	" 42 (since dead).
" 30.	" 44.
" 33 (since dead).	" 45.

Deaths and Causes.

Case 1 ...	Sleeping sickness.
" 3 ...	Disappeared; presumably dead.
" 5 ...	? Sleeping sickness (no records).
" 9 ...	Sleeping sickness.
" 10 ...	Sleeping sickness.
" 33 ...	? Delayed CHC ₃ poisoning; marked mediastinal changes at necropsy.
" 42 ...	Pneumonia.
" 43 ...	Died on admission.

While it may be early to state positively that the present treatment promotes definite cure, we cannot help but feel optimistic in the face of the results we have obtained. Several of our cases have gone well beyond a year with one dose of treatment, and they have all invariably improved in health and no trypanosomes have been found, though they have been subjected to repeated and careful investigations.

Most of our cases have been treated with Burroughs Wellcome and Co.'s neo-kharsivan, a few cases were also treated by atoxyl, the object being to find out which is the more efficient drug. We also mean to use other drugs such as galyt and also tartar emetic, and we hope to be able to publish during the next year (1921) comparative results of the various drugs used.

Experiments are also being made to see whether the results we have up to now obtained may not be due to the formation of trypanolysins or other antibodies. That the trypanosomes give rise to specific lysins was suggested by Louis Martin and Henri Darre, who attributed the fever to the massive destruction of the parasites by trypanolysis, and who showed that the blood of patients obtained at the onset of fever had a very marked trypanolytic power both *in vitro* and *in vivo*. We have therefore treated one or two well chosen cases with plain serum—that is, the serum from one of our treated cases was injected into the blood and cerebro-spinal fluid of another sleeping sickness patient; up to now it is much too early to form any opinion.

Conclusions.

1. Of 56 cases treated up to now, 8 are dead. Of 6 of these we have records, and of these 6 only 3 died of sleeping sickness, the others dying of an intercurrent disease, favoured, may be, by the trypanosome infection.

2. All the remaining cases are doing well, some (21) have only been treated during the last six months and so are excluded from this paper, though included in the index of cases.

3. The drugs tried so far have been neo-kharsivan most extensively, and to a less extent atoxyl, but all that has been said in this paper refers mainly to neo-kharsivan.

4. Plain serum treatment is also being tried in a few carefully selected cases. In advanced cases we are trying direct spinal medication; so far the results are uncertain—one case treated thus died; another, under observation, in whose spinal cord 0.003 gram neo-kharsivan was introduced, seems to present a certain amount of improvement.

Finally, we wish to express our thanks to Dr. C. A. Wiggins, Principal Medical Officer of this Protectorate, for his assistance and encouragement in carrying out these investigations and for his permission to publish this report.

REFERENCES.

- ¹ M. Nierenstein, BRITISH MEDICAL JOURNAL, June 5th, 1920. ² R. van Sacklieghem, *Bull. Soc. Path. Exotique*, May, vol. 8, No. 5, pp. 339-348; and also with L. Nicolas in the same *Bulletin*, 1916, vol. 9, No. 10, pp. 811-823. ³ Hans Ritz, *Archiv f. Schiffs- u. Trop. Hyg.*, 1916, September 20th, No. 17, pp. 397-420; also A. Stuehmer, *Zeit. f. Immunitätsforsch.*, I Teil, Orig., 1916, March 4th, vol. 24, No. 4, pp. 315-335.

THE VIRULENCE OF DIPHTHERIA-LIKE ORGANISMS.

A NOTE ON THE INTRACUTANEOUS TEST.*

BY

A. J. EAGLETON, M.D. LOND.

AND

E. M. BAXTER, M.Sc. SHEFFIELD.

For testing the virulence of diphtheria-like organisms, Zingher and Solet-sky¹ described a method of intracutaneous injection which was a modification of that originally described by Neisser. They advocated the method on the grounds of economy, and stated that in 60 cases it gave the same result as the subcutaneous method. These authors usually tested four strains on each pair of guinea-pigs.

We have been using a similar test for some months, and are submitting our experience of it in the hope that it may prove useful to the many public health pathologists in England who are working in the same field. The modifications we have introduced are as follows:

1. Standardization of inoculum by opacity.
2. Inclusion of a known virulent strain in each test.
3. Injection of control animal on the preceding day.
4. Administration to the unprotected animal of a "following dose" of antitoxin of such a size that the skin reactions are not obscured while the life of the guinea-pig is saved.

The technique of the test is as follows:

Two guinea-pigs are used for each test; both must be partially white.

Protecting Dose.—One animal is given 500 units of diphtheria antitoxin by intraperitoneal injection on the day preceding the test. This animal acts as a control.

Preparation of Inoculum.—The test strains and a known virulent diphtheria bacillus are grown eighteen hours on Loeffler slopes, emulsified in saline, diluted and standardized by opacity so that the suspension contains approximately fifty million organisms per cubic centimetre.

Injection of Suspensions.—White-haired portions of the guinea-pigs are depilated with calcium sulphide paste, and into corresponding skin areas of the two animals is injected 0.2 c.c.m. of each suspension. The injections are strictly intradermal and at least half an inch apart. On each pair of animals we usually test eight or ten strains, including the control virulent.

Following Dose.—Four or five hours later the animal which was not given a protecting dose on the previous day receives 125 units of diphtheria antitoxin intraperitoneally.

Readings are taken for the next three days.

In the case of a virulent diphtheria bacillus the control animal shows nothing or a faint transient flush; the other animal shows a definite rose-red swelling which becomes more marked at each successive reading, and may terminate in slight necrosis. An avirulent diphtheria-like organism gives a negative result with both animals. If the test culture is contaminated with streptococci the result may be obscured by a reaction in both animals, but this does not always happen.

The advantages of the test are:

1. Economy of animals, as both survive.
2. Owing to the variability of growth shown by different strains, standardization by opacity is preferable to the use of a certain proportion of a slope culture as in the American method.
3. Reliability. We have had the opportunity of comparing only a limited number of strains by the subcutaneous injection method; so far the agreement is satisfactory.

REFERENCE.

- ¹ Zingher and Solet-sky: *Journal of Infectious Diseases*, vol. xvii, No. 3, 1915.

* From the Wellcome Physiological Research Laboratories.

MUCH is hoped in Germany from the regulation, made at the beginning of 1921, prohibiting the exploitation of Wassermann's test by persons unrecognized by the health authorities as competent to carry it out. A further precaution to secure a reliable Wassermann test is the decree that only those extracts must be used which have been tested at the Institute for Experimental Therapy, conducted by Professor Kolle at Frankfurt a. Main.

THE LINGUAL APPLICATION OF IODINE AS A PROPHYLACTIC IN CEREBRO-SPINAL MENINGITIS AND INFLUENZA.

BY

J. A. TAYLOR, M.B., D.T.M.,

SENIOR MEDICAL OFFICER, UGANDA PROTECTORATE.

THE treatment of cerebro-spinal meningitis by the application of iodine to the tongue led me to try it also in this manner as a prophylactic for the same disease, and for influenza during the epidemic in the Mbarara and Kigezi districts, Uganda, in 1918-19.

In both diseases the site of infection appears to be the respiratory passages, possibly most frequently the pharyngeal tonsils, and my assumption was that the iodine would to some extent cause disinfection of the mouth, throat, and tonsils, and thus prevent or reduce the intensity of the disease. Moreover, the iodine increases the flow of saliva which in itself is prohibitive to the growth of the organisms, and a four-fold action is thus brought into force:

1. The local disinfectant action on application near the site of infection.
2. The action of the increased flow of saliva.
3. The action of the iodine after absorption.
4. The excretion of the iodine in the saliva and respiratory passages again acting as a disinfectant.

Ordinary tincture of iodine (B. P.) was mixed with an equal part of native honey, and, in the case of cerebro-spinal meningitis, instructions were given that two or three drops of this mixture should be placed on the tongue of contacts two or three times daily. A large number of cases of cerebro-spinal meningitis among natives was being reported monthly throughout the district, and all that can be said as to results is that no contacts who used it developed the disease, and the number of deaths reported fell in a few months from an average of 100 to an average of 40 a month. Strict isolation of contacts, however, was in force before the use of the iodine, and it was unusual for contacts to become infected after segregation. It is therefore doubtful whether the iodine had any effect, but the natives themselves had great confidence in its efficacy.

In influenza the results appeared to be more definite. No attempts could be made to distribute an experimental medicinal prophylactic among the natives generally; distribution was therefore confined to ten Europeans, about 100 Asiatic clerks and shopkeepers, and a few native chiefs, clerks, and servants of Europeans. The iodine was used in the same manner, but with the recommendation that applications should be made at least every three hours, or more frequently if convenient. This was in November, 1918, when the first suspicious case of influenza occurred near Mbarara. Towards the end of December the disease became prevalent throughout the district, and nearly every person, except some of those to whom the iodine had been distributed, suffered from the disease in a more or less severe form. Among the Europeans, who all used the iodine more or less regularly, no case occurred, although many were in daily contact with persons suffering from the disease. With regard to the Asiatics and natives to whom the iodine had been distributed, it was impossible to ascertain in most cases with what regularity the prophylactic had been used, but a large number escaped infection altogether, and others had the disease in a mild form with no complications. None of the natives using it died; the death rate among those who did not was high. Among the Asiatic population also there were no deaths, as compared with a mortality rate of 6.53 per cent. throughout the Protectorate.

Many instances occurred which appeared to prove the efficacy of the prophylactic and the value of frequent applications. In one family the father, who was in daily contact with influenza cases in all stages, used the iodine regularly and escaped altogether, while the remainder of the family, who had used it less regularly, had mild attacks. In another case, one child appreciated the taste of the mixture so much that he managed to obtain frequent applications and escaped infection, while all the rest of the family had slight attacks.

I have refrained from publishing these notes until now as I considered the results far from convincing. During

the past year, however, I have had the opportunity of seeing several records of the use of iodine taken internally both in the treatment of and as a prophylactic for influenza. Possibly the iodine after lingual application instead of acting as a local disinfectant had its chief action through absorption, but personally I am convinced that its use saved several lives. Moreover, during the past year I have had the opportunity of using it with contacts of isolated cases of influenza, and all have escaped the disease. Possibly painting the tonsils and the back of the throat with iodine would be of greater value, but I consider this would be a too elaborate and unpleasant procedure to be adopted as a general prophylactic with regularity, whereas the placing of a few drops on the tongue is a very simple matter and may prove as efficacious if done with sufficient frequency.

I wish to thank Major C. A. Wiggins, Principal Medical Officer, Uganda Protectorate, for permission to publish this paper.

Memoranda:

MEDICAL, SURGICAL, OBSTETRICAL.

BILATERAL HYPOGLOSSAL PALSY DUE TO GUNSHOT WOUNDS.

A SIMULTANEOUS wounding of both hypoglossal nerves unaccompanied by any other serious injury, must be an uncommon event. I have short notes of two such cases and, though the records are imperfect and may show obvious defects from the neurological point of view, yet they may possess some interest.

CASE I.

Lance-Corporal S., wounded September 15th, 1916. A small fragment of shell has passed transversely across the infra-mandibular region. The wounds of entry and exit are both small, and correspond in position on the two sides. They are situated immediately below the mandible at the junction of the middle and posterior thirds of the horizontal ramus. Both hypoglossal nerves are paralysed. The patient cannot thrust his tongue forward, but can deviate it slightly from side to side, though not sufficiently to touch his cheek. He can dorsiflex the tongue, though not to a full degree, and can retract it fully towards the pharynx. The movements appear to be performed by the pharyngeal and extrinsic muscles, the tongue itself being almost inert except for the power of dorsiflexion. There is no loss of tactile sensation or of taste for salt in either half of the tongue. His pronunciation of the letters of the alphabet is given below.

CASE II.

Private G. N., wounded by rifle bullet, October 16th, 1916. The bullet has passed transversely below the lower jaw. The entry and exit wounds are small and symmetrically placed on the two sides immediately below the mandible, a quarter of an inch in front of the angle. The movements of the tongue are similar to those in Case I.

Pronunciation of the Letters of the Alphabet.

	CASE I.	CASE II.		CASE I.	CASE II.
A	ah	N	en
B	be	O	o
C	ce	P	pe
D	ve(?)	Q	hoo
E	e	R	ar
F	eff	S	ess
G	ve(?)	T	te
H	hitch	U	oo
I	i	V	ve
J	wri	W	bubbleoo
K	fi	X	ex
L	ell	Y	wi
M	em	Z	reb
					zeb(?)

Regarding the vowels, neither of the patients could pronounce A, as in day, or a long E, while in Case I U could not be pronounced as yew. In Case II the only consonants which were quite impossible were G and J, while in Case I D, K, Q, T, W, and Z also offered complete stumbling-blocks. In Case II the pronunciation of D was doubtful, there being a very small sound of the consonant, which was overshadowed by the forcible expiratory sound which accompanied it, and careful attention was required to appreciate the "D." Speaking generally, there were but few articular sounds which were quite impossible, though there was a general lack of distinctness in the enunciation, while excessive expiratory efforts were brought into use in the endeavour to give precision to the individual syllables and words.

Southsea.

HAROLD BURROWS, F.R.C.S.

Reports of Societies.

THE TREATMENT OF TRYPANOSOMIASIS.

At the meeting of the Royal Society of Tropical Medicine and Hygiene on May 20th, the President (Professor W. J. R. SIMPSON) in the chair, a paper was read by Dr. CLAUDE H. MARSHALL on "A new method of treatment of trypanosomiasis," embodying the results given in an article by himself and Dr. Vassallo which is printed in full in this issue of the BRITISH MEDICAL JOURNAL (p. 773). Dr. Marshall's previous report on the treatment of sleeping sickness by combined intravenous and intrathecal injections of "salvarsanized serum" appeared in the BRITISH MEDICAL JOURNAL of May 22nd, 1920, p. 702. A former patient, the only European patient, to whose case Dr. Marshall referred in detail, was present at the meeting, and was congratulated by the President and others on his appearance of excellent health. After relating particulars of the technique, the cases, and the results, substantially as in the paper published in this issue, Dr. Marshall went on to suggest that the curative effect of the serum treatment resulted from the formation and action of some form of trypanolysin. If the theories of Dr. Vassallo and himself were correct, there was no reason why animal serum should not be used for treatment, why some degree of prophylaxis and immunity to trypanosomiasis should not be obtained, and why early diagnosis should not be effected by some form of complement fixation test. Dr. Vassallo was now carrying out experiments on these lines. The line of treatment adopted for human beings might probably be applied to animals; the cure of "fly" disease in horses and cattle should prove of great economic value, but he appealed for the assistance of the veterinary branch of medical science in such researches, in particular for the co-operation of a veterinary officer in future work.

The PRESIDENT said that he considered the investigation to be one of the most important that had ever been placed before the Society. If the results described were maintained in the future and were confirmed by further investigation it opened up a new and brilliant era for the prevention and treatment of trypanosomiasis. What that meant for humanity they could imagine by recalling the vastness of the region infested by the tsetse fly. Dr. Marshall's observations were not carried out on the lower animals, but on men and women, and the results certainly seemed to indicate a reduction in the mortality in one form at least of the disease. Dr. Marshall had rightly excluded 23 cases treated for less than six months, but that left a series of 30 cases, of which it was found that 22 (or 73 per cent.) were alive and well after more than six months, while of 13 cases treated for over a year 9 (or 69 per cent.) were alive and well. This was putting the successes at their lowest. It remained to be seen whether the same favourable results could be obtained in the Rhodesian type of trypanosomiasis. He saw no reason why this should not be, seeing that treatment was based on a scientific foundation. He hoped that some movement might be inaugurated for putting this treatment to the test on a larger scale. He agreed that the veterinarian should come in to assist, and other scientific workers also, but a Rockefeller was badly needed to help financially.

Professor W. D. HALLIBURTON dealt specially with a point referred to him by the President—the reason why in cerebro-spinal trypanosomiasis it was of no use injecting anything into the blood. The cerebro-spinal fluid, he said, was really a secretion not a leakage fluid from the blood. It was sometimes called the lymph of the brain, but that was a very slipshod expression, for in lymph there was always a possible passage of materials in both directions, from blood to lymph and lymph to blood, whereas in the case of this particular fluid there was a passage of only a constant saline material which maintained the normal osmotic pressure which was beneficial for the life of the nerve cells, and in disease as well as in health the choroidal cells maintained a stalwart barrier against the entrance of foreign material which might be circulating in the blood. Only one or two volatile materials, of which alcohol was the best known, got through. It was a matter of congratulation to Dr. Marshall and his colleague that they had found a material which was fatal to the parasite but not fatal to the host.

Dr. P. MANSON-BAHR asked whether the invasion of the cerebro-spinal fluid was necessary to produce the sleeping sickness; he held that it was not. He had one case from the Congo, first infected in 1916; there was little doubt that the patient had trypanosomiasis, but during five years, only on one occasion had trypanosomes been found in his blood. His state of trypanosomiasis was most typical, and yet for three years now there had been no direct scientific evidence for the condition. In another case under his observation Dr. Marshall's and other treatments had been tried without making the smallest difference to the number of trypanosomes found in the blood. In estimating the effect of drugs on trypanosomiasis the fact must be taken into account that the protozoa had a periodic habit in the blood; in the case in question they reappeared every three weeks, the man usually having about sixteen trypanosomes for every 200 leucocytes. The speaker held that there was no reason why trypanosomiasis should not be a self-limiting disease, and the wonderful cures reported might be due to the nature of the body resistance rather than to any drugs injected.

Dr. G. C. LOW supported the criticisms of Dr. Manson-Bahr, and asked what foundation there was for supposing that a few cases treated up to thirteen months had been cured. He did not think that a case could be regarded as cured until after a period of at least three years. Sleeping sickness had probably become more chronic in form in Uganda since he himself began the study of it there twenty-one years ago, and this was the more reason against being over-definite in the description of results as cures after so short a period of time.

Dr. W. T. PROUT refused to take such a pessimistic view as Dr. Manson-Bahr and Dr. Low, and he thought that the indications were that Dr. Marshall's use of the word "cure" was justified.

Dr. C. F. HARFORD thought that the cases which filtered through into our hospitals at home could not be classed in the same category as the cases dealt with in the country of their origin, and this might account for the differences of opinion among observers.

Dr. MARSHALL, in a brief reply, said that because quinine and salvarsan had occasionally no effect in malaria and syphilis respectively, that was no reason why they should not remain as routine treatment, and he thought that the same principle held good in the matter under discussion. Dr. Low had suggested that it was too soon to say that the patient who had been brought forward that evening was cured, but at any rate he did not look as though he were troubled by sleeping sickness or anything else! The European had a higher resistance to trypanosomiasis than the native. Dr. Marshall added that he and his colleague in Uganda would very much welcome further tests.

Colonel R. H. ELLIOT said that a number of members of the Society who were interested in varying degrees in Dr. Marshall's work felt that an opportunity for the further continuance of that work ought to be given. Some representations should certainly be made to the Colonial Office in favour of a complete investigation, not only of human but of animal trypanosomiasis. They all knew the anxiety which the disease had given to the Government of Uganda, and the enormous advantage which would accrue if the treatment proved effective.

Sir HUGH CLIFFORD, Governor and Commander-in-Chief of Nigeria, said that the tropics seemed to be differentiated from the rest of the world by their subjection throughout recorded ages to the domination of insect-borne disease. This fact had determined their history to a great extent and the character of their people. It must be admitted that Dr. Marshall's discoveries called for further investigation, and experiments should be carried out systematically and scientifically by the ablest officers. He would personally address the Secretary of State on behalf of the Government he represented, urging that this important discovery should be taken up scientifically by the medical department in Nigeria, and if it was going to cost a few thousands his Government would not grudge the expenditure in so good a cause.

Dr. JENSEN then proposed and Colonel ELLIOT seconded a motion that the Society was of opinion that every facility should be given for the furtherance of Dr. Marshall's work and investigations. This was carried unanimously, and it was understood that the resolution would be conveyed to the Colonial Office.

FIBROUS AND MUSCULAR ATTACHMENTS OF
THE VAGINA.

At a meeting of the Obstetrical Section of the Royal Academy of Medicine in Ireland, on April 29th, with the President, Dr. E. HASTINGS TWYFIDY, in the chair, Dr. LOUIS CASSIDY read a paper on the fibrous and muscular attachments of the vagina. In the course of his communication he showed (by various lantern slides) that the lower two thirds of the lateral walls of the vagina were in close apposition with the levatores ani muscles. Interposed between the lateral walls of the vagina and these muscles was a distinct layer of fascia—a portion of the visceral layer of the pelvic fascia—which gained a very definite attachment to the walls of the vagina. This layer was clearly demonstrable, and was intimately blended with the fasciculi of the levatores ani muscles. When followed forwards immediately below the neck of the bladder this fascia was found to be continuous with the pubo-vesical ligaments, whilst behind it passed into the fascia surrounding the rectum. The surface of this layer of the fascia, which rested upon the levatores ani, sent prolongations into the muscle to blend with its sheath, thereby indirectly supporting the vagina. The anterior and posterior fascial supports of the vagina resolved themselves into the attachments between the fibrous covering of the posterior wall of the urethra and the anterior fibrous sheath of the rectum behind. The attachment between the wall of the urethra and vagina was a very close one, the structures being morphologically continuous, and was associated with the presence of the dense mass of fibrous tissue which in this region occupied the space left by the disappearance of the female prostate; it was impossible to separate the two structures in their lower two-thirds, the knife had to be used. The union of the lower three-fourths with the rectum and anal canal was much less intimate and permitted of easy separation. This relationship between the rectum and vagina was much strengthened at the junction of the rectum and anal canal by the presence of the perineal body. This structure was a wedge-shaped mass consisting of fibro-muscular tissue, and was about one inch in depth, the base of the wedge lying at the skin surface (Tandler).

The vagina pierced the two layers of the triangular ligament, and consequently received firm support from this structure. The muscular attachments of the vagina were solely comprised by the levatores ani. A transverse section through the pelvis of a female child aged 19 months, and taken through the middle of the true pelvis, demonstrated the attachments of fibres of the levatores ani muscles to the lateral walls of the vagina. This relationship was denied by such eminent authorities as Halban and Tandler, as well as Cruveilhier. In conclusion, the writer was convinced that the prevention of a hernial protrusion of the anterior and posterior walls of the vagina depended on the lateral support it received from the pelvic fascia and the integrity of the perineal body. He considered this latter structure of paramount importance in the mechanical support of the female pelvic diaphragm. There was one other point to which attention might be drawn—the presence of the transversalis colli, or Mackenrodt's ligaments. These structures would be readily recognized in transverse section through the pelvis of a young female child. That these ligaments did very materially support the upper third of the vagina there could not be much doubt.

Dr. GIBBON FITZGIBBON agreed with Dr. Cassidy about the value of the pelvic fascia. Referring to the parietal and visceral layers, he thought that anatomists did not go far enough. He was of opinion that the former was merely the covering of the levator ani muscle. The actual supports of the vagina were well shown by Dr. Cassidy. He thought there was just as much fascia round the parametrium as in Mackenrodt's ligaments. The parametrium was all muscular and contained very little fascia, and this was the real support of the vagina.

Dr. BETHEL SOLOMONS was greatly struck by the fact that in Dr. Cassidy's ardent researches it had been found that Mackenrodt's ligaments were not the only supports of the vagina. He believed that in further research the essayist would find that Mackenrodt's ligaments were probably the most important but not the only supports of

the pelvic viscera. The old argument, that in cutting through these ligaments the fact that the uterus descended proved that these were the only supports, did not hold water, any more than the fact that after the removal of one limb the body being supported by the other proved that the body was supported by one lower limb. He asked the essayist what constituted the pillars of the bladder which were so useful in acting as supports for the bladder in the operation for the cure of cystocele. Did he consider them to be a portion of the pubo-occygeus muscle with or without fascia, or possibly the detrusor muscle of the bladder?

The PRESIDENT regretted that Dr. Cassidy had not gone further and demonstrated the attachments of the uterus, but hoped he would bring it forward on a future occasion. In his (the President's) opinion these fibrous attachments were the supports of the uterus as well as of the vagina. The Master of the Rotunda (Dr. FitzGibbon) was right in saying that the strands of fibrous tissue in the pelvis ran in every direction, and different names—Mackenrodt's ligaments, utero-sacral ligaments, etc.—had been given to different bundles of these. The theory of the pelvic fascia was fascinating. He believed that the uterus was the origin of these strands, which grew out from it in all directions, and they might fitly be described as "uterine tendons." These tendons or ligaments contained muscle, and were under the control of the uterus, and, he believed, were its sole support.

Primary Carcinoma of the Vagina.

Dr. GIBBON FITZGIBBON showed a specimen of primary carcinoma of the vagina, from a patient aged 42, 7-para, whose last pregnancy, four years ago, was normal. Her menses were regular and normal, and she was quite well up to two months ago, when slight bleeding from the vagina started and continued. On examination, the vulva and perineum were quite healthy. From the right lateral fornix of the vagina there was an ulceration extending slightly on to the posterior wall and down the lateral wall to about an inch and a quarter from the hymen. The ulcer looked very clean, the surface a little irregular and soft, and the edges fairly sharp. There was no evidence of rectal or bladder involvement. The ulcer ran close up to the cervix, but did not encroach on its mucous membrane. By the rectum a hard nodule could be felt under the ulcer, extending out towards the pelvic wall, but mobile. The surface of the ulcer was removed with the curette and some pieces of the edge cut away for examination.

The pathological report was that it was a definite cancerous growth, showing dense masses of cells.

First, by the abdomen, the ordinary lines of a Wertheim's hysterectomy were carried out, until the whole of the vaginal fornices were quite freed. The internal iliac vessels were cleared and tied at their origins. The patient was then put into the lithotomy position and the vagina divided just inside the hymen all round and separated up, taking as much of the tissue in the ischio-rectal fossae as possible, until the detached upper part was reached, when the whole mass of the vagina and uterus was removed through the vulva. The edges of the vulva were fixed with a few stitches and the rest of the operation done by the abdomen. The pelvic peritoneum was closed over a gauze packing. The patient was severely affected by shock, but responded well to a coffee enema, followed by small saline enemata during the next twenty-four hours, and made an uninterrupted recovery, the abdomen healing perfectly.

A few days before operating on this case Dr. FitzGibbon operated on another patient in whom the cancer was also primary in the vagina and situated in the lower half, just coming down to the level of the hymen. There was a mass extending out to the ischio-rectal fossa and a hard ring round the vagina, but the ulceration was only lateral. In this case he removed the whole vagina from the lesser labia, the edge of the perineum, and the external meatus of the urethra up to the vaginal fornices, and taking the vaginal portion of the cervix. Of the two operations he considered the former was the easier. There was less haemorrhage, owing to the internal iliac vessels having been tied, and the removal of parametrium above the fornices was much more complete and simple. Should he have to operate on cancer of the vagina again, he would do the operation—including the removal of the uterus—in three stages, as in this case. It was surprising how little arterial bleeding occurred, only two or three small vessels requiring to be tied, but there was rather profuse venous

bleeding for a time, and this was avoided in the case with hysterectomy.

Dr. SOLOMONS, Dr. MADILL, and the PRESIDENT spoke and Dr. FITZGIBBON replied. Dr. R. E. TOTTENHAM showed a new type of pelvimeter.

RENAL DIABETES.

At a meeting of the Royal Medico-Chirurgical Society of Glasgow, held on April 15th, the PRESIDENT occupying the chair, Dr. ADAM PATRICK described a case of renal diabetes. In the normal person, he said, the blood sugar varies from about 0.07 per cent. to about 0.15 per cent., or rather more. If the latter concentration is exceeded, sugar appears in the urine. In healthy persons it is difficult to raise the blood sugar above this level. In the diabetic the threshold concentration is habitually exceeded, and readings of 0.25 per cent., or much higher, may be obtained. A single reading of this kind is enough to establish a diagnosis of true diabetes. Sugar may also appear in the urine if the renal threshold is lowered, even if the blood sugar does not exceed the normal. In the normal subject the limit of sugar concentration is reached in about an hour, whereas in the diabetic the maximum is not reached for two or three hours. The case described, that of a man aged 38, was found to have glycosuria on examination for life insurance, although five years before there was certainly none. His health had been good, save for an attack of haematuria (cause unknown) ten years before. At the latter date there were no symptoms. Treatment on the lines suggested by Allen was instituted without great success, and the urine only remained sugar-free on a diet approaching starvation. In hospital it was found that on a very restricted diet, and with the blood sugar reading only 0.05 per cent., there was a trace of sugar in the urine; on ordinary diet there was abundant sugar in the urine two and a quarter hours after dinner, although the blood sugar was only 0.114 per cent. Tested by administration of 25 grams of glucose after a sixteen hours' starve, the blood sugar curve was normal in type. The name "renal diabetes" is applied because the glycosuria appears to be due to a defect in the kidney.

Professor MUNRO KERR read notes of a case of resection of a double uterus, followed by two full-time pregnancies. He also showed the uterus, which had been removed after a Caesarean section. The diagnosis lay between an extra-uterine pregnancy, a myoma contracting a uterine pregnancy, and a pregnancy in the horn of a double uterus. Matters were cleared up by the expulsion of the ovum from the right horn of a uterus bicornis. The patient had a second miscarriage at a later date from the same horn. Both miscarriages occurred at the third month. The resection of the uterus (uterus bicornis unicollis symmetricus) was done seven months after the last miscarriage. A V-shaped wedge was removed and the two halves of the uterus carefully stitched together. Pregnancy followed soon afterwards and proceeded to full time. A living child was delivered with forceps, but died owing to injuries sustained at birth. The uterine scar was found by manual examination to be quite satisfactory. Some months later the patient again fell pregnant, and at full time Caesarean section was performed and the uterus removed. Professor Munro Kerr demonstrated the uterine scars on the anterior and posterior walls of the uterus. These, especially that on the anterior wall, were satisfactory, but there was a gutter-shaped indentation in the posterior wall over which the placenta was attached. Microscopically a great deal of connective tissue was seen in the scars, particularly in the posterior one. The operation had been done on one or two occasions in Continental clinics, but so far as Professor Munro Kerr knew, not previously in this country. The indication for the operation was the repeated miscarriages, which seemed to be common in this form of malformation.

Dr. JAMES HENDRY described a case of amenorrhoea following severe trauma. In May, 1919, the patient reported three months' amenorrhoea without other signs of pregnancy. Her appearance suggested thyroid insufficiency, and there was no sign of pregnancy. The disturbances suggesting thyroid insufficiency were only of recent date, and her health previously had been good. Treatment with thyroid extract was prescribed and continued for a

few weeks without any improvement, and, in fact, the patient became stouter and more drowsy and apathetic. On again reviewing her history in detail, it was discovered that a few weeks before the patient's first missed period she had fallen in the street on the back of her head during frosty weather. Next day her sight was affected and vision was almost lost, but had almost completely returned. Dr. Hendry then thought of a possible lesion of the pituitary gland, and administered orally tablets of pituitary (whole gland) without any success. By June, 1920, a fairly well developed Frohlich's syndrome had shown itself—dystrophia adiposo-genitalis, with lethargy and somnolence; menstruation had returned in scanty form, lasting one day. A skiagram of the skull to show the sella turcica was obtained, and signs of a fracture were marked. The patient, further, could ingest 300 grams of glucose without glycosuria. The oral administration of pituitary gland having proved unsuccessful in most points, pituitrin, administered by hypodermic injection, was tried, with no success. Five months ago, hypodermic injections of antuitrin (extract of the anterior lobe) were commenced, and weight was now steadily diminishing, although food intake was normal. Regarding sugar tolerance, 120 grams of glucose now produced glycosuria. The special interest in this case was the association of amenorrhoea with hypopituitary function.

VITAMINS.

At a meeting of the Pathological Society of Manchester on May 11th, Professor E. MELLANBY, M.D., of Sheffield University, lectured on vitamins. He stated that in consequence of two discoveries namely, (1) that some proteins have a higher food value than others, (2) vitamins—the isodynamic theory of diet must be abandoned. Diet had now become a question not of quantity but of quality, and the whole science of nutrition was in the melting-pot. He traced the history of the experimental work on vitamins, including the work of Hopkins in 1911, when it was proved that animals would not grow on purely synthetic foods.

Describing the three recognized vitamins, (1) anti-scorbutic, (2) anti-beriberi (water-soluble B), (3) anti-rachitic (fat soluble A), he explained that they had in common the properties that their chemistry was entirely unknown, that animals could not synthesize them but could only obtain them from the vegetable world, and that they were influenced greatly by the way in which our food was treated. Experiments were described showing the effect of vitamins on calcification processes, the prevention of rickets and the production of good and bad teeth. The consideration of rickets was complicated by the fact that it was a disease of growth. Enlarged epiphyses could be produced by any method leading to a deficiency of calcium in the body. Anti-rachitic vitamins prevented rickets by allowing the body to make use of the calcium at its disposal. In experiments in which animals were kept on a rickets-producing diet, it was found that, other factors being constant, the more white bread that was given the worse was the degree of rickets, whereas meat had a slight anti-rachitic effect. Dealing with the controversy concerning the etiology of rickets, Professor Mellanby outlined his grounds for the view that diet was the chief factor, and exercise and sanitation purely subsidiary.

The question of dental caries was then discussed in the light of experiments which showed that the main factor in its causation was not lack of cleanliness but improper feeding during the period of formation of the teeth. The experiments showed that when once good regular teeth were produced in dogs they were much more immune to caries than were irregular, badly formed teeth produced on rachitic diet, and it appeared that fat-soluble A was the all-important factor. The question whether there were more vitamins to be discovered was often asked, but had not been conclusively settled. There were certainly other factors in diet the importance of which was unknown at present. The thyroid gland was examined in dogs fed on a diet containing various fats; when fed on butter, cottonseed oil, or linseed oil, the thyroid was invariably large, and resembled histologically that of Graves's disease, whereas on a diet containing cod-liver oil it was small and histologically normal.

At a meeting of the London Association of the Medical Women's Federation, held on May 10th, with Mrs. FLEMING, M.D., in the chair, Miss E. C. LEWIS, M.S., F.R.C.S., read a paper on "Tuberculous adenitis, its diagnosis and treatment." She confined her attention to the superficial glands, of which the most important were the cervical, which were affected in about 93 per cent. of the cases of superficial adenitis. The reason for their peculiar vulnerability was the importance of their drainage area, since they receive lymph from the teeth, tonsils, tongue, and palate. The age-incidence of cervical adenitis was the same as that of chronic simple enlargement, the greater number of patients being under 10 years of age. All varieties of adenitis were commoner in the female sex. Miss Lewis discussed the clinical picture of these cases and gave a detailed account of important points in diagnosis between tuberculous adenitis, lymphadenoma, and chronic septic adenitis. Other forms of glandular enlargement, such as those due to syphilis and new growths, rarely led to difficulty in diagnosis. In describing treatment stress was laid on the importance of early diagnosis, of clearing-up septic processes in the drainage area of the glands, and of general medical treatment before operation was undertaken. The value of x-ray treatment in cases where glands had broken down was emphasized. A discussion followed, in which Dr. JANE WALKER, Dr. E. CARLING, Dr. R. JORDAN, Miss WHITE, Miss C. KING, and others took part.

Reviews.

INTESTINAL TOXAEMIA.

DR. ALEXANDER BRYCE,¹ the author of *Intestinal Toxaemia or Auto-intoxication in the Causation of Disease*, hopes that although primarily designed for the medical profession, his clearly written book may, in spite of scientific terms, appeal to a much wider public. Briefly expressed, his view is that of Dr. A. Haig, with the important substitution of "toxic substances" for "uric acid" as the fons et origo of numerous human ills. His outlook is therefore on much the same lines as those of Metchnikoff, Sir Arbuthnot Lane, Kellogg, and Danysz, though he is not a slavish follower. He has obviously had considerable personal experience, and read widely in connexion with his subject. The objections to the conception of auto-intoxication from intestinal stasis are stated from the standpoint of "the pure scientist," for whose "meticulous caution" in accepting conclusions without indisputable proof he expresses sincere admiration. Dr. Bryce frankly admits that there is probably no single disease which can with absolute confidence be identified as the direct product of intestinal toxæmia, and that there are many diseases of such obscure origin that it is tempting to ascribe them to toxic absorption. But he is inclined to regard the evidence in favour of his thesis as circumstantial, and this is duly set out with full references to the work of others. The most convincing proof of the doctrine of auto-intoxication, he thinks, is to be found in the benefit obtained from the adoption of methods designed to combat it. These are a correct diet with a low protein content, fleshless, and taken in meals three times a day; an action of the bowels after each meal; encouragement of saccharolytic and discouragement of proteolytic bacteria in the intestine; and attention to all the laws of health. A weekly intestinal douche is recommended; the vertigo sometimes attributed during the summer to liquid paraffin can thus be prevented. The objection to paraffin that it may escape from the anus apart from defaecation, can be obviated by taking it once only in the twenty-four hours, and just before going to bed: failure of paraffin to penetrate the faeces can be met by taking bran or agar-agar, the faeces being thus rendered more permeable.

PATHOLOGY OF THE BLOOD.

THE second, enlarged, edition of BURNETT'S *Clinical Pathology of the Blood of Domesticated Animals*,² though dated 1917, only reached us on March 21st, 1921. It is intended

¹ *Intestinal Toxaemia or Auto-intoxication in the Causation of Disease*. By Alexander Bryce, M.D., C.M., D.P.H. London: Andrew Melrose, Ltd. 1921. (Cr. 8vo, pp. 191. 6s. net.)

² *The Clinical Pathology of the Blood of Domesticated Animals*. By S. H. Burnett, A.B., M.S. Second edition, revised and enlarged. New York: The Macmillan Co. 1917. (Med. 8vo, pp. 182; 23 figures. 13s. net.)

for the use of veterinary surgeons and for those who need to know details concerning the common experimental animals. It is arranged as is usual in textbooks of human haematology, and makes full use of data obtained from these sources. The first two chapters are devoted to methods of examination and morphology. In the third chapter details are given of the normal blood counts of various animals. There follow chapters on red and white cell variations; on special, general, and infective diseases; and on diseases due to protozoa and parasites. The illustrations are plentiful and good.

The author is professor of comparative pathology at the New York State Veterinary College, and many of his comments are well worth the attention of clinical pathologists. We do not remember to have seen in any textbook of haematology any such statement as the following: "The liver is the organ best adapted to distinguish, by histological examination, leukaemia and pseudo-leukaemia from generalized sarcoma. The characteristic collections of cells found in pseudo-leukaemia and leukaemia do not occur in sarcoma." Medical literature contains some hundreds of papers devoted to the differences between these diseases, but without any mention of this point, which constitutes an easy and accurate means of distinguishing them. On the other hand, page 13 conveys the intelligence that the standard solution in Sahli's haemoglobinometer is "haemoglobin in glycerin," and the author seems to prefer the very unstable solution of Gower to the Haldane modification or to that of Sahli. Nor can we agree with the statement made of Hodgkin's disease on page 92, that it "cannot be differentiated from lymphatic leukaemia anatomically or histologically if the blood be excepted."

The book is thus uneven in its merits. This is perhaps due to the fact that the author has relied chiefly on the textbooks of Ewing, Cabot, Da Costa, v. Limbeck, Naegeli, and Grawitz, none of which have seen new editions for many years.

THE PSYCHOLOGY OF FUNCTIONAL NEUROSES.

THE volume entitled *The Psychology of Functional Neuroses*³ is the outcome of the experience Professor HOLLINGWORTH gained from the study of 1,200 soldiers with persistent neurotic symptoms in the U.S. Army General Hospital. He made systematic observations to determine the intellectual status of these patients by the usual intelligence tests, and upon the results obtained he formulates a theory to account for neurotic manifestations as a whole.

According to Professor Hollingworth, all psychopathologists have missed the essential factor in the genesis of neurotic symptoms, and these are not, as Freud, Jung, and Adler would have us believe, the expression of disturbances in the emotional and instinctive sphere, but are rather the result of intellectual deficiency. In the first place, the author utilizes Hamilton's term, "redintegration" to explain all nervous reactions. "Redintegration," he writes, "is to be conceived as that type of process in which a part of a complex stimulus provokes the complete reaction that was made previously to the complex stimulus as a whole." This concept, which incidentally has been freely utilized by every psychopathologist of whatever school of thought, the author finds to be one "that is significantly descriptive of the psychoneurotic picture, that unerringly identifies the patient, explains the psychogenesis and idiosyncrasy of his symptoms, points the way to therapy and prophylaxis, and is yet intrinsically intelligible, is relevant to the systematic accounts of the average mind, and for which a neural counterpart or correlate is without difficulty conceivable." Thus far psychopathologists will scarcely take exception to the writer's views. He has repeated something with which they are perfectly familiar and which expresses no new idea. When the shell-shocked soldier hears a gun fired or any sudden noise all his previous fear reactions—tremors, mutism, and so on—are, of course, apt to return. The explanation here given, however, of these abnormal reactions is so contrary to the concepts of modern psychopathology that it requires much more proof than is brought forward in this volume. These symptoms the

³ *The Psychology of Functional Neuroses*. By H. J. Hollingworth, Associate Professor of Psychology in Columbia University. New York and London: D. Appleton and Co. 1920. (Demy 8vo, pp. 271. 10s. 6d. net.)

author ascribes to an intellectual defect, a lack of *sagacity* or ability to comprehend properly the part in relation to the whole and to discriminate out of a whole the appropriate, relevant, or significant detail. A neurosis is thus apparently to be regarded as a form of congenital intellectual deficiency. The psychoneurotic is deficient in *sagacity* as the feeble-minded is in the capacity for *learning*. We should have imagined that there was quite sufficient evidence to show that the redintegrative reactions in the psychoneuroses were the result of the suppression of painful experiences rather than the expression of stupidity. Professor Hollingworth objects to the whole terminology and conceptions of the psychopathologist, and there is here, no doubt, a legitimate field for criticism, but he would scarcely seem to be in a position to dispute the basic conceptions which have been formulated as to the significance of neurotic symptoms. If he objects to the concept of the unconscious, he need only refer to the work of Schwab in his own country in which an objective and physiological conception of the psychoneuroses is developed, but this writer finds, as all psychopathologists have hitherto done, that these disorders have their origin in the instinctive rather than in the intellectual mental life.

The actual data upon which the author bases his hypothesis are by no means convincing. It is true that he finds many of his cases slightly subnormal in intellectual level, but these patients are obviously in no sense representative of the psychoneurotics found in civil life, and neither can they be regarded as characteristic of the mentality of the whole group of war neurotics. However this may be, 787 out of the 1,172 cases tabulated in his book are not neurotics at all, but are classified under the headings of mental deficiency, epilepsy, constitutional psychopathy, concussion, cerebro-spinal meningitis, organic conditions, psychoses, and undiagnosed. While this study may have some value as a mere record of the mental level of a number of nervous cases, as a contribution to the psychology of psychoneurotic symptoms it is of but little significance.

STEDMAN'S MEDICAL DICTIONARY.

We have remarked before on the debt owed by English-speaking members of the medical profession to the United States for the many excellent medical dictionaries produced in that country, and for the speed with which revised editions are brought out. The sixth edition has now reached us of the *Practical Medical Dictionary*,⁴ by Dr. T. L. STEDMAN. It is only ten years since this work first appeared, and the favour with which it has been received is proved by the fact that a second edition was needed within eighteen months, and that since then a new edition has been called for every second year. The first edition was noticed at some length in our columns at the time. The general style and arrangement have been preserved, but the number of pages has had to be increased to keep pace with the ever-growing number of new words and altered meanings. With a lexicon of this size and scope the work of continuous revision and correction must be very heavy; the author speaks of it in his supplementary preface as a truly Sisyphean task, "one edition being no sooner published than the collection of new words and new uses of old words begins anew." So far as we have been able to test the new edition, this dictionary appears to maintain the accuracy and the clearness of definition which have made it so popular as a work of reference in medical libraries.

ELECTROTHERAPY IN UROLOGY.

DR. COURTADE has collected into one volume, entitled *Notions pratiques d'électrothérapie*,⁵ much that is useful to know on the subject of electrotherapy applied to urological conditions. There is perhaps no branch of surgery in which electrotherapy holds a more important position than in the surgery of the genito-urinary system, and Dr. Courtaud's book should certainly be of great utility. To write a work of this kind requires special

qualifications such as few men possess. It needs a greater knowledge of electrical instruments than most medical men have, and at the same time demands considerable experience in urology. Dr. Courtaud appears to be eminently fitted for the task which he has undertaken. The book is divided into two parts. In the first part are described the different varieties of an electrical current, the means by which they may be generated, and their action on tissue in general. The second part is devoted to a consideration of the various lesions of the genito-urinary tract that are amenable to electrical treatment. Advice is given as to the best form of such treatment for the various lesions described, and, where possible, the reasons are supplied why a particular form of current is better than another. Although the second portion of Dr. Courtaud's book does not contain a great deal of new material, certain minor changes are effected which are doubtless improvements. The work should prove interesting to urologists and electrotherapists alike.

NOTES ON BOOKS.

IN his *Letters to a Nurse*, "A Midland Doctor" (who from the preface we may suppose to be Dr. F. G. Layton) provides some instruction for probationers on the nature and origin of disease, and on the duties of nurses to patients. The instruction is sound and on the right lines. But the author's main purpose appears to be to encourage the probationer with his fatherly—or avuncular—advice to endure the drudgery and hardships of her early training, and at the same time to rebel against certain abuses, such as bad feeding, excessive hours of duty, and the deadening hospital routine. Incidentally the letters are used as a means of attacking many priests and some matrons and ward sisters. The matron or sister who is a martinet may well have attention directed by a doctor to her shortcomings, but the priest is in a different position; there seems to be no good reason why the Midland Doctor should use his letters to nurses as a medium for an attack on another profession; especially when, in doing so, he may hurt the religious susceptibilities of some young women. It would be wiser to address a separate series of letters to a priest. By using Lord Chesterfield's method, and addressing letters to his niece, the author is able to allow himself much latitude in style. But his illustrious predecessor would hardly have written "the very most difficult": "conscious 'doing good' is the very most priggish of vices"; "we know different, don't we?" or "I shall go and find out what is the reason why." The vigour of his sentiments may be gathered from his denunciatory remarks on charity and the voluntary system; his sense of humour by his quotation of the message from a lady patient, "Will you please call to-morrow as little girl is ill at your convenience and oblige."

⁴ *Letters to a Nurse*. By a Midland Doctor. London: J. Bale, Sons and Danielsson, 1921. (Fcap. 8vo, pp. 93. 5s. net.)

APPLIANCES AND PREPARATIONS.

A Draining Rack.

THE "Rycott" draining rack, of which we have received a sample, is a simple wooden device for draining glass tumblers, measure glasses, and cups. Articles after being washed can be placed between the slits of the pegs and left to dry, as shown in the illustration. The rack is made either to stand on the table or to fix on the back of a sink; single pegs are also made to

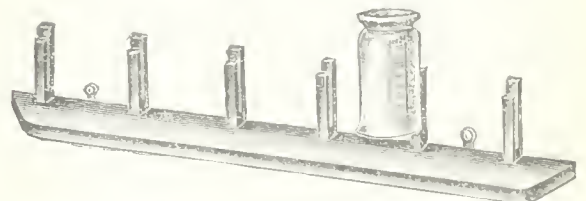

screw on the side of the plate rack or the draining board. The rack, or pegs, should prove a convenience in laboratories, dispensaries, and photographic dark rooms. The price of the rack is 2s., and single pegs are 3d. each. They may be obtained from Messrs. Maw, Son and Sons, or from the makers, Messrs. Rycott and Dixon, 115, Ballham Hill, London, S.W.12.

THE (Czecho-Slovak Red Cross has organized forty country colonies for a total of 10,000 children and will shortly open a children's hospital.

⁴ *A Practical Medical Dictionary*. By Thomas Lathrop Stedman, A.M., M.D. Sixth revised edition. London: Baillière, Tindall, and Cox, 1921. (Roy. 8vo, pp. 1160; illustrated. 42s. net.)

⁵ *Notions Pratiques d'Electrothérapie Appliquée à l'Urologie*. By Dr. D. Courtaud. Second edition. Paris: E. Le François, 1921. (Roy. 8vo, pp. 244; 37 figures. Fr. 18; post free, Fr. 19.80.)

THE ORGANIZATION OF SCHOOL OPHTHALMIC WORK.

BY

N. BISHOP HARMAN, F.R.C.S.

ALL the mental and physical powers of a child are brought into play in school life. Defect in one of these powers will act as a handicap. The child with a defect will not be able to do so well in work or in play as the better equipped child. Some defects are more than handicaps; they may become irritants and react on the general welfare of the child. A child with some degree of deafness will fail to hear low tones; the failure is a loss. The sensitive child may be aware of the loss and worried by it, but the effort to hear will involve no ill effect. A child with defective sight will fail to see clearly; the loss may cause worry, but more serious is the likelihood that the effort to see will cause a strain that may further damage the eyes and even disturb the balance of the nervous system. The ill effects of defective sight are progressive and cumulative. If we leave out of account the dominant part played by sight in the development of human mental and physical powers, still the significance of defective sight is such that no effort is lost which seeks to diminish or ameliorate the defect.

The Discovery of the Defect.

Parents are so accustomed to their children and their ways that they can rarely be relied upon to notice any but the most obvious defects. The school becomes the testing ground of the physical qualities of the child even as it is of its mental capacity. Mentality and physique are so closely involved that teachers need as much training in the observance of physical characters as they receive in scholastic and mental culture. It is desirable that teachers should receive in a course of school hygiene instruction in the recognition of simple eye defects, such as the recognition and dangers of sore eyes, the seriousness of squint and the urgency of its early and continuous treatment, and in the methods of measuring and recording visual acuity. An educated and observant teacher is the first line of defence in protecting the child from the strain arising out of its inherent disabilities. Every teacher ought to know the meaning of a vision test-type, and be able to discover the value of a child's sight by the use of that test and to record it. Many teachers have learnt this during school medical inspection; not a few instances have come under notice of the value of this knowledge; one may be cited:

During the visit to a school for a purpose unconnected with inspection a school doctor was asked to look at a boy, for his teacher had noticed that he could not see properly; the previous term's vision had been 6/6; when he was tested by his teacher that week his vision was only 6/60; examination of the boy showed that he was suffering from acute optic neuritis.

The test-types should be a familiar object in the school, and it should be of such a kind that it cannot be memorized however frequently seen. For this reason experience shows the advantage for the school use of the E-sign card, in which there is only one sign for each grade mounted on a turntable that may be moved at will. The test cannot be learned; it requires no knowledge of letters; the response is simply the movement of the hand to correspond with the position of the pointers of the sign.

There appears to be no reason why an initial test of vision should not be done by the teachers; it would give them a knowledge of their charges that they would not otherwise obtain, and it would accentuate their interest in the conservation of child sight. These preliminary findings would be at the service of the school medical inspector at his visitation. Observant teachers are most of all necessary in infant departments. At present infants under the age of 7 years attending school do not have their eyes examined; yet I have shown by a routine examination by objective methods of the eyes of all the infants attending a large good class elementary school to the number of 368 that 36.9 per cent. had defects of the eyes and no less than 16 per cent. considerable defect (*Trans. Ophthal. Soc. U.K.*, 1919, p. 89). These infants, fit and unfit, do the same work; and it must be remembered that what we adults think easy infantile tasks are in reality very laborious and fatiguing to infants. It is not practical to attempt to distinguish these defects by a vision test with test-types. The test could only be made satisfactorily by the routine objective examination of the

eyes of each entrant by the medical officers, just as though the child had been referred to the clinic for defective vision. If such a course could be adopted it would be possible to indicate the normal eyed (or rather average eyed) children, those with slight defect of vision, and those with more serious defects, and to suggest arrangements for the work of these grades of children according to their fitness. It is likely that an educational arrangement based on a real knowledge of the condition of the children's eyes and the correction of the gross defects at an early age would tend to check the onset of much of the myopia we find developing in later years. Such a proposition may be deemed impracticable in the present state of public finance. The burden of detecting the serious defects of infants' eyes, therefore, rests with the teachers. Infants who squint, even if only temporarily, whose eyes get tired, red, or irritable after work, or who fail to see marks on the blackboard or the details of wall pictures, should be noted and referred to the school medical officer. Similarly children who appear dull or stupid in general class lessons should be referred for examination, for it has been shown that many "stupid" children are stupid from inability to see. These signs of eye-strain should equally be noted by the teachers in other departments and reported.

The Measure of the Work to be Done.

The data given above, obtained by the objective examination of the eyes of infants at a good class school, show that 16 per cent. had serious defects that needed medical attention. Certain of the children with less serious defects will also need attention, let us say these will bring the total to 20 per cent. In London, with an average roll of 725,000 children, the average number of entrants in any year is 63,000, so that the minimum number of children requiring attention each year would be 12,600. To this must be added the number likely to require re-examination, who are about one-fourth of that number for any one child-year, or, let us say, for the several years of school life, a number equal to the entrants examined, making a total of 25,000 examinations each year. London school population numbers about one-seventh of that for England and Wales, so that the grand total on a low estimate will be about 176,400 for each year. The actual numbers of children attending London school clinics as fresh cases during the years 1912 to 1920 inclusive were: 16,670, 21,464, 25,952, 25,286, 26,905, 27,062, 26,200, 28,011, 29,837, making an average for the nine years of 25,400.

Treatment of Defects.

It should be premised that any arrangement made for the treatment of eye defects in children should be in close relation with the schools, so that the results of the treatment may be available for the guidance of the school authorities. Many of the defects found are not completely susceptible to full correction, and the remaining defect may be one that requires special arrangements for the satisfactory education of the child. If the arrangements for treatment are not made with this close relation to the work of the school, a large part of the benefit of the treatment may be lost. When school clinics are provided by the education authorities there is no difficulty in making the desirable connexion; and it does not appear impossible to secure a like conveyance of the necessary information when the child is treated independently of these arrangements by the private practitioner of the parents' choice.

Arrangements for School Clinics.

These will differ in town and country. In towns where there are large aggregations of children it is easiest and best to plan definite clinics in suitable places which may serve a number of schools. In small towns satisfactory schemes are now in working whereby the local practitioner competent in ophthalmic work receives the children who are to be examined in his own house; the arrangement is economical, since it avoids the expense of setting up an independent clinic for a relatively small number of children. In the country these plans will be unsuitable, as schools may be far apart and the numbers in each may be small, so that a clinic could not be economically arranged to serve a given area. In the country, therefore, treatment is best carried out in the school premises by doctors who attend the schools in rotation on a plan prepared by the chief school medical officer. The apparatus needed by the doctor can be readily transported from place to place. The provision of a room suitable for ophthalmoscopic examination is not a matter of difficulty; any room that can be darkened and in which a suitable lamp can be provided will meet the need. Where electric light is in use a focus lamp appropriate for the particular current of the district,

with a length of flexible wire, is all that is needed; where gas is used the incandescent mantle provides a most satisfactory source of light, provided the bracket to which it is attached is placed low enough. Where there is no fixed source of light supply illumination can be best provided by a portable acetylene lamp, of which there are many good patterns on the market. In towns, clinics will be arranged either on hospital premises, if these are conveniently situated, or at independent centres where these facilities are absent.

About 2 per cent. of children in the schools suffer from blepharitis and conjunctivitis. In many of these the need is for regular and efficient cleansing. In town areas this is best met by the establishment of "minor ailment centres," where, under the control of a medical officer, there is a staff of nurses who give daily attention to the cases. It is desirable that where these centres are established they should be definitely linked up with the centres where the more detailed investigation of defects is carried out. Some of these cases of sore eyes are aggravated or caused by defects of refraction, and unless these are recognized and corrected there is no real likelihood of the surface irritation being checked. In country districts the care of such cases can be best met, in the absence of any provision of school nurses, by arrangement with local nursing associations, so that nurses could be detailed off to schools at definite hours each day to undertake the cleansing of children with affected eyes, and the application of the treatment ordered by the visiting doctor.

Following-up.

Examination of school clinic papers shows that even where there are satisfactory arrangements for the following-up of children under medical treatment, the treatment or a continuity of treatment is often neglected. If this be so where there are efficient arrangements, how much more must be the loss where these arrangements do not exist or are elementary! It is desirable that some arrangement should be instituted whereby cases that need regular observation at stated intervals may be marked and reported to the school medical officer, so that the continuity of treatment and observation can be secured even when the child is removed from one area to another.

Provision and Repair of Spectacles.

In towns where clinics are established arrangements should be made whereby an optician attends at the clinic to fit spectacle frames to the children. This plan has many advantages over the plan of sending the children to the optician. When the former plan is adopted there is personal communication between doctor and optician, corrections and adjustment of frames are expedited, and, further, the time of the parents is saved materially. In country districts where the numbers are few the selection of frames should be done by the medical officer himself. He should be supplied with a set of half a dozen standard frames with which he can ascertain the proper fitting for each child, and to the form of prescription he should add the number or description of the chosen frame.

Some difficulty arises in the provision and repair of glasses owing to inability of parents to pay at the time of ordering the glasses. It does not seem desirable that these should be provided free of cost to the parents. When this is done there is a tendency to lack of care in their use, but when they are paid for by the parents much more care is noticed. If the parents of children who are found to have eyes that will need the regular use of glasses during school life could be invited to join a provident scheme into which they could pay regularly small sums to meet the cost of glasses and their repair, the difficulty would be met. Great saving of time would be effected through such a scheme, and particularly if local opticians came into it. At present children who need glasses badly are often without them for long intervals while funds are being raised and repairs made in distant workshops. In country districts a postal service for the supply and repair of glasses will be needed.

The care of spectacles may be materially advanced by a routine parade of all children wearing them, at stated intervals. It should be a duty of the head teacher to supervise the parade, and it would be advantageous if one of the teachers who had some mechanical aptitude were to undertake those small adjustments of bent, tight, or loose frames which add so much to the comfort of the wearers. This plan has been adopted in some large schools with excellent results.

Staff.

There will need to be variations in arrangement according to the type of district in which the work has to be done.

Identical arrangements will not fit town and country. In general it may be said that there are advantages in separating the work of school medical inspection from the treatment of children found to be defective.

(1) The assurance provided by the independence of the two officers provides against objections by parents who resent the allegation that there is a defect in their child; it gives a certainty to the finding that is conformable to that which we demand for our own children and indeed for our own persons. (2) Medical inspection involves a sound all round knowledge of children's physique, and it is not to be expected that a medical inspector with this full general knowledge will be also equally competent to deal with a number of specialities involved in the treatment of defects. (3) In the case of eye defects there are additional advantages to the community as a whole in arranging that the treatment of the defect should be spread over as wide a personnel as possible. At the present time there are not a sufficient number of practitioners with an expert knowledge of eye work to meet the growing demand. The equipment of an education medical staff to do the work for children is a practical proposition, but if this work be done by practitioners whose sole duty is educational, the services of these practitioners will not be available for the service of the community at large. It would appear, therefore, desirable that the treatment of eye defects should be carried out by private practitioners who give evidence of a competent knowledge of the work and will devote a definite part of their time to it. Such an arrangement would foster the supply of a rapidly increasing number of capable practitioners who would have a knowledge of the particular difficulties and dangers of eye defects in industry by their daily contact with the adult population, and therefore be the better able to advise on the education of the children and indicate that line of training which would best fit them for a lifework in view of the defects which may be present.

Since the work of a school eye clinic is so largely refraction work the one test of competency for the practitioner in these departments is the mastery of the retinoscope and ophthalmoscope. The practitioner must have such a mastery of retinoscopy as will enable him both to work out every detail of the refraction with the mirror and to judge from his results what are the most appropriate glasses to order in any given case. He must be able to make his observations with reasonable speed, for the examination is tiring to children. Subjective tests are of little or no value for children and should serve only as a record of visual acuity under certain conditions.

The appointing authority cannot itself test the competency of candidates for the work, but it can and should require evidence of recent and sufficient work in the ophthalmic department of a teaching hospital or of private work over a sufficient period.

It is desirable that country school circuits and independent town clinics should be linked up with some central clinic under the charge of an experienced ophthalmic surgeon for the purpose of consultation or reference for special examination of difficult cases. Where a school clinic is established on the premises of an existing hospital special arrangements for these purposes are unnecessary, as they are made by the hospital staff. In other clinics there may be no such arrangement for consultation, so that the practitioner in charge of the clinic loses necessary assistance, and the best line of treatment for the children cannot always be secured. The establishment of such central clinics at existing hospitals would have an advantage in facilitating in-patient treatment and operation where such were needed. The officer of the local clinics should be at liberty to refer any case of difficulty for consultation, and should be specially invited to refer those cases where visual defect cannot be satisfactorily corrected and where no certain cause explains the failure, serious defects likely to handicap the child's education, cases where special educational methods appear necessary, and cases requiring extended treatment and operation.

Arrangements for Special Treatment.

A small percentage of the children suffer from disease of the eyes which are of a chronic order and connected with some general disability or defect in hygiene, such as chronic conjunctivitis, blepharitis, relapsing ulcer of the cornea, and syphilitic and tuberculous inflammations of the eyes. The danger to the eyes which these diseases present is such that treatment to be adequate must be so organized as to be immediate and continuous and therefore institutional. Treatment in clinics and out-patient departments of hospitals does not meet the need. The hygienic conditions of the child cannot be touched by such

measures. Further, unless the child is under complete control during the treatment, intermissions are likely to occur, and in just those cases where the danger is greatest. Arrangements should be made for the immediate report of such cases to the consultative clinic, the officer of which should be able to recommend the admission of the child to a suitable institution where the treatment may be carried out.

One of the difficulties in carrying through continuous treatment of this sort for a necessary period lies in the intervention of capricious parents, who cannot be brought to understand the seriousness of the conditions. It is worth considering whether this difficulty might not be met by the routine reporting of these cases as they arise to the local magistrates to whom fall the decision in school cases, so that their assent to treatment for a specific period might be obtained in advance. If the parent does not enter into some engagement, or the retention of the child be not obtained by other means, the success of the treatment may be prevented by the untimely withdrawal of the child, so that the heavy expenditure is wasted, the damaging effects of the disease are not prevented, and a permanent disability may follow.

Children with Serious Defect of Vision.

There are a number of children, averaging about 2 per 1,000 of the school population, whose vision is too bad for them to take advantage of the ordinary curriculum. Special arrangements are made for their education under the provisions of the Education Act of 1893. Difficulties arise in these cases on three counts: (1) The insufficiency of the provision for their education, (2) the occasional objection of parents, (3) the lack of general knowledge on the part of medical practitioners of the nature and reason for special provision for these children.

(1) The number of schools for the blind in the country appears sufficient. But despite the sufficiency there are found even today cases of young people who are blind within the meaning of the Act, and have been so for many years, and yet whose education has been "attempted" in ordinary schools. Cases such as these indicate a defect in the arrangements for reporting the findings of medical examinations and treatment, and point to the necessity for effective consultation arrangements as indicated above. It is imperative that these children should be provided with satisfactory educational treatment at the earliest possible age. Delay means a serious and irrecoverable loss to the child, and a far more expensive and prolonged training after school years to put them in the way of a satisfactory occupation. The provision for children with less serious defects of vision is less ample. It is being met in the towns where the numbers make it possible to provide special accommodation. This is best provided by the formation of small classes—"myope classes"—in the ordinary elementary schools, so that the children may remain associated with the normal children for part of their curriculum. There is a distinct disadvantage in providing for them in blind schools or in other independent centres, for segregation is likely to cause them to be thought more nearly akin to blind children than to the sighted, and therefore to handicap their start in life. In villages the needs of these short-sighted children may best be met by allowing them to remain in the ordinary schools, provided the teachers are informed of the nature of the defect, and of the prohibition of reading and writing except by methods in use in the myope classes.

(2) Parents who cannot be persuaded of the seriousness of the defects of their children's eyes sometimes evade the acceptance of proper provision by transferring them to private schools, where the nature of the defect may be unknown and unprovided for. Later, when the seriousness of the defect is realized, the children are once more referred to the education authority, and often at a date too late effectively to meet the needs of the children.

(3) Occasionally difficulties arise from a lack of knowledge of the meaning of educational blindness on the part of medical practitioners, so that a conflict of opinion as to the proper training of a defective child arises between the school doctor and the private practitioner. The more widespread the association of those engaged in these two branches of medical work the less will be difficulties of this sort; hence the advantage of associating as many private practitioners as possible with school medical treatment.

The Influence of School Medical Work on the General Community.

School work should not be considered in relation only to education as carried on in the schools. It is true that the primary object of the work is to prevent eye-strain, the aggravation of eye defects, and to remove a handicap that would diminish the value of education to the child. But there are other values. The lessons that are learned in school life are a preparation for the wider life of the community. And in some degree the inculcation of a sound system of treatment of eye defects of the school children will react upon the whole community. There is much

industrial inefficiency caused by ignorance and negligence of eye defects; when the knowledge of the necessity and possibility of the correction of these defects is widespread the gain will be great. Parents are learning this lesson through the work done by the school medical service, and a new generation of parents will have learned the lesson by practical experience.

SOCIETY FOR RELIEF OF WIDOWS AND ORPHANS OF MEDICAL MEN.

THE annual general meeting of the Society for Relief of Widows and Orphans of Medical Men was held on May 18th at the offices of the Society, 11, Chandos Street, Cavendish Square, with Sir ALFRED PEARCE GOULD, President, in the chair.

The following report for 1920 was adopted:

Report for 1920.

Since the last report 11 new members have been elected and 6 have been lost owing to death and resignation. The Society consists at the present time of one honorary, 163 life and 137 ordinary members, making a total of 301. The annual subscription for a member who at the time of his election is under 40 years of age, is two guineas, if over 40 but under 50 three guineas, and if over 50 four guineas. There are special terms for life subscription.

The invested capital now stands at £144,250. By the By-laws only the income may be used for the payments granted for the relief of the widows and orphans eligible to receive grants. All life subscriptions and legacies are funded. The income from investments amounted to £4,682 5s. 2d., £373 2s. 1d. was received from subscriptions and donations, making a total income of £5,055 7s. 3d.; the working expenses were £299 7s. 6d. During the year two widows came upon the funds and three died. The sum of £4,584 was distributed among the annuitants of the charity. On December 31st there were fifty-two widows and six orphans in receipt of grants.

The Society, which is one of the richest of its kind in the United Kingdom, was founded in 1788, and incorporated by Royal Charter in 1864. Membership is open to any registered medical practitioner who at the time of his election is resident within a twenty-mile radius of Charing Cross. Should a member remove anywhere outside the radius, even beyond the British Isles, he nevertheless remains a member of the Society, provided he has conformed to the By-laws. Relief is granted to the necessitous widows and orphans of deceased members of three years' standing and of life members.

At the present time the widow of such member who has an income of not more than a hundred pounds a year receives a grant, voted each half-year by the Court of Directors, at an average rate of £50 per annum, paid half-yearly in advance, and each orphan, up to the age of 16, receives a grant of £45 per annum. An orphan, on attaining the age of 16, by the By-laws of the Society ceases to be eligible to receive grants from the ordinary funds of the Society. There are, however, two special funds from which the Court of Directors can make grants to orphans after the age of 16, and special grants from £25 to £10 are made to widows.

The acting Treasurer drew attention to the fact that the working expenses of the charity were about 5 per cent. of the total income, which he considered most satisfactory.

A cordial vote of thanks was passed to the editors of the various medical journals for their courtesy in publishing notices of the Society from time to time.

Further particulars may be obtained on application to the Secretary. The next election of members will be on July 6th, 1921.

THE last quarterly return of the Registrar-General shows that 129,263 deaths were registered in England and Wales during the three months ended March 31st, 1921. This corresponds to an annual rate of 13.9 per 1,000 total population in 1920; it is the lowest rate recorded in any first quarter since the establishment of civil registration. Influenza was stated to be either a primary or a contributory cause of death in 3,235, or 2.5 per cent. of the total deaths registered last quarter. Of the 209,667 births, 9,505 were illegitimate. Infant mortality, measured by the proportion of deaths under one year of age to registered births, was equal to 101 per 1,000, being 17 per 1,000 below the average in the ten preceding first quarters.

FROM August, 1919, to March, 1921, 66 persons received prophylactic treatment for rabies at the Utrecht serological institute, 19 were treated in 1919, 39 in 1920, and 8 in 1921; the disease did not develop in any case. During the same period the animals in Holland attacked by rabies consisted of 1 horse, 4 cows, 41 dogs, and 1 cat. The cases all occurred exclusively in the four provinces of Groningen, Drenthe, Overijssel, and Gelderland.

British Medical Journal.

SATURDAY, MAY 28TH, 1921.

PRE-NATAL DEATH.

THE third Sir John Struthers Lecture, which was delivered before the Royal College of Surgeons of Edinburgh on December 17th, 1920, has recently become available in print. The lecture was by the Professor of Anatomy in the University of Edinburgh, and was worthy of Professor Arthur Robinson's high reputation. The subject was pre-natal death, a matter about which not a little has been written in recent years; but the pre-natal death referred to was not that commonly meant, and the term was used in a sense that differed widely from its accepted obstetrical employment.

By pre-natal death Professor Robinson means a sort of normal or necessary extinction of life due to the fusion of certain gametes (ova and spermatozoa) which, though in themselves quite healthy, yet by their union produce zygotes which have either no vitality to carry them further or only sufficient to take them a short distance or in a tattered condition along the path of ante-natal life. The zygote or impregnated ovum resulting from the meeting of certain ova and spermatozoa which from the point of view of persistent vitality must be called germinally incompetent or incompatible, is a weakling or a failure, and its failure is followed by an abortion which Professor Robinson calls "normal"—using the word "normal," however, in a rather special sense. With some other ovum such a sperm might give a living and a lively zygote, and similarly some other sperm might prove competent enough with the defaulting ovum; there is, in other words, an incompatibility at the moment of impregnation; the destined ovum is not met by the delegated spermatozoon, and so the zygote falls or can only stagger for a few paces along life's highway. To apply Augustine of Hippo's old phrase in a new fashion, the zygote comes into being carrying with him his own mortality (*circumferens mortalitatem suam*).

In coming to this conclusion that in a certain percentage of all germinal conjunctions there is this incompatibility with resulting mortality, Professor Robinson has been influenced by a series of observations he has made upon horses and mares (Clydesdales and thoroughbreds) and upon ferrets. By finding the ovum-extrusion rate and comparing it with the actual birth rate in these animals, he reaches what is termed the "pre-natal death rate." In the Clydesdales it varied from 46 to 50 per cent. and in the thoroughbreds from 52 to 62 per cent.; in the ferrets it was not more than 39 per cent. and was most likely about 35 per cent. A pre-natal death rate (as above defined) is not peculiar to horses and ferrets, but occurs in other animals, amongst which swine, rabbits, guinea-pigs, and *Dasyurus* (among the marsupials) are mentioned, as are likewise birds. Professor Robinson, therefore, asks himself the question, Why not also in the human subject? It should be mentioned that he took great care to avoid the intrusion of certain obvious fallacies; the parent animals were healthy, their environment was as usual, the

food was not altered, and there was no evidence that there was excessive use of the male. Neither could the pre-natal deaths be due to the "internal environment," the immediate surroundings in the genital organs, for dead and normally developing ova and young zygotes were found in the same passages; indeed, in the ferrets a dead zygote or a degenerate zygote was frequently situated between two normal zygotes. Professor Robinson is therefore justified in asking, Why not also in the human subject? If this question be answered in the affirmative, we have to ask whether any change for the better in the surroundings of the expectant mother or in her health can increase the birth rate?

At this point great care must be taken to make sure that like things shall not be compared with unlike. Professor Robinson's "inevitable pre-natal death" (although even here the word "inevitable" is scarcely permissible) is not to be confused with the avoidable stillbirth due to the use of high forceps when Caesarean section or the induction of premature labour ought to have been employed. Neither is it within the same category as abortion due to parental syphilis and preventable by the use of the salvarsan substitutes and mercury. It is possible to agree with Professor Robinson that some sterility is "normal" and unavoidable and that some pre-natal death is also "normal" or usual, and under ordinary circumstances cannot be avoided, without assenting to the "better dead" argument that we shall abandon all efforts to save ante-natal lives and to prevent sterility. The lecturer was careful to point out near the close of his most interesting address that he was not then concerned with the remaining and avoidable part of pre-natal mortality, but a special word of caution is needed in respect of Professor Robinson's conclusion that the condition of the uterine mucous membrane associated with normal abortions is not degenerative or diseased, but normal, and that treatment of it is not only unnecessary, but may probably be detrimental. It can only be after a careful process of exclusion that the diagnosis of a "normal" abortion can be made, and until that has been reached it would be unwise to rule out uterine curettage, which has often been followed by the birth of a full-time child after one or even more abortions. Of course other means of treatment are not to be neglected.

Professor Robinson frankly admits that the human "normal pre-natal death rate" cannot at present be fixed; but he thinks that about half of it may be regarded as due to causes which, in a sense, are unavoidable, and therefore as not remediable by any treatment, local or general, of the mothers. He does not, however, make it plain that the type of pre-natal death to which he refers occurs possibly, if not probably, very early in ante-natal time, soon after, if not actually before, the date of the first missed menstrual period. His "normal" abortions, therefore, may be amongst those which, by their early incidence, escape the statistician and do not come under the treatment of the obstetrician. Professor Robinson's observations and conclusions do not, in fact, afford the obstetrician any excuse for relaxing his efforts to prevent miscarriages or for abandoning his efforts to save ante-natal lives. There is, however, the necessity, in forecasting the probable percentage of ante-natal lives which are capable of being saved by hygiene and treatment of expectant mothers, to make allowance for the pre-natal mortality which, in the present state of our knowledge and of our therapeutic means, is fitly to be described as inevitable. There are still many lives which fall to the child welfare physician to save, and the time is not yet

¹ *Edinburgh Medical Journal*, March and April, 1921, pp. 137-151, 209-231.

when, with all these safely carried on to birth, there shall remain no others except the zygotes inevitably foredoomed to extinction. Even in respect of these last it has yet to be shown that good hygiene among the parents, spread over several generations, may not diminish the number of the failures.

THE TYPHOID CARRIER.

The typhoid carrier problem, about which so much has been written, is brought once again before us by Dr. William Travis Howard, jun., in a valuable study of the history of enteric fever in Baltimore during the last seventy years.¹ We may first refer to some of the more general features of his paper. Although the mortality attributed to this disease at Baltimore is still greatly in excess of that observed in English urban aggregates (the rate in 1919, corrected for non-residents, was 6.28 per 100,000, which may be compared with 1.4 for London, 1.5 for county boroughs, 1.6 for other urban districts, and 1.5 for rural districts), it has declined greatly in the last fifty years, having been nearly 100 per 100,000 in 1870 and over 70 as recently as 1890. Down to the year 1881 opportunities for the pollution of the water supply were abundant, but by that date great improvements had been effected, and, with the exception of a few years following the incorporation of new districts into the city, the typhoid curve descended for twenty years. After 1901 fresh pollutions of the water became abundant and the curve tended to rise until, after chlorination of the supply in 1911, a sharp descent began.

During the whole period between 1851 and 1894 conditions were very favourable for the pollution of milk. Much was obtained from cows kept in the city in circumstances appropriate for contamination by actual sufferers from typhoid or "carriers," while the milk was heavily watered from polluted wells and springs. After this period matters improved. The urban cow was to a great extent driven out, and the municipal authorities gave effect to the advice of their medical officers. A revolution in the control of milk supply followed the enforcement of ordinances in 1908 and 1912, the Health Department acquiring control of dairy farms outside the city. Yet, as late as 1917, nearly 8 per cent. of the reported cases were traced to milk. Dr. Howard remarks that unless milk bottles are uniformly sterilized as a matter of routine, bottled milk may be, during the prevalence of typhoid, more dangerous than milk served from the old-fashioned churn. "When milk is sold from the churn or can, the purchaser receives it in his own container, and the dairy takes nothing infected away from the householder."

The Baltimore authorities seem to deal drastically with "carriers"—in fact, to "apprehend" them. Whether the causal nexus established between the alleged carrier and the outbreak would usually satisfy Dr. Hamer is, perhaps, open to doubt. We will quote one of Dr. Howard's examples. It is that of a family in which, during a period of seventeen years, four outbreaks of typhoid in three generations had occurred. "The grandmother had contracted the disease seventeen years before; the next year her two sons, her son-in-law and daughter and an unmarried daughter, all living in the same house with her, developed typhoid fever. In June, 1916, this woman's grandchild, aged 7 years, who lived in her house, developed the disease. On January 2nd, 1917, a second grandchild, a sister of the first, was reported as a case of

typhoid fever. The whole family was cultured on January 8th, 1917, and the grandmother, the unmarried aunt, and the child who had had typhoid fever in June of the previous year, were all three found to be carriers."

The sequence is impressive, but some of Dr. Howard's arguments are not quite convincing. He instances the case of a coloured cook found "to be a carrier responsible for 9 cases of typhoid fever among college girls, and who appeared to be quite frank when submitted to the closest interrogation was unable to recall a febrile illness suggestive of ordinary clinical typhoid fever. She described, however, very clearly the symptoms of an attack of acute cholecystitis which she had had about a year before. . . . Had she not by chance transferred typhoid infection to a number of college girls at the same time, she would probably not have been apprehended. Upon such chances as these the transmission of this disease and the recognition of its mode often depend. None of this woman's personal associates gave a history of frank typhoid fever either before or after her attack of cholecystitis. . . . A large proportion of the several hundred food handlers whom I have had cultured with negative results may be intermittent carriers, infecting from time to time people not intimately associated with them." This reasoning amounts to the following: A has access to the food supply of B, C, D, E, etc.; B, C, and D develop typhoid fever, and A is found to carry the typhoid bacillus; therefore A has infected B, C, and D. If A is not found to be infected, he may be an intermittent "carrier" and still responsible. As a matter of administration, to segregate A in the former and to keep an eye upon him in the latter case are plainly correct courses; but the logician will certainly say that what has been shown is not causation but correlation, and that if, as Dr. Howard hints and others have hinted, the carrier state is extremely common, then the argument from correlation is not so impressive as it appears.

The whole point of such sequences as that of the grandmother and her descendants, and of the negro cook and the college girls, depends upon the assumption that the odds against the mere fortuitous concurrence of half a dozen cases of typhoid and the presence of a carrier are enormous. In our opinion, that assumption may be safely made, and the carrier assigned a definite and not unimportant part in the etiology of typhoid as a sporadic or minor epidemic disease. To go further and to see in the carrier the prime factor of dissemination of typhoid would be unwarrantable, and we think that the following words of Dr. Howard have more than local application: "Now that the City Fathers, after many years of fumbling, have finally made the general sanitary provisions necessary for the reduction of the incidence of typhoid fever to a comparatively low level, in the old twenty-four wards, and the obvious may be set to one side, the public health administrator of an inquiring turn of mind may turn himself to the much more interesting and important problem of determining the less obvious or hidden means of transmission of the disease."

ADVANCED LECTURES IN LONDON.

ANNOUNCEMENTS recently made by the University of London of advanced lectures on medical subjects illustrate an improvement that is quietly being made in the facilities for advanced medical students and visitors to London. The lectures are specially addressed to the former, but they are open to others interested in the subject without

¹ Johns Hopkins Hospital Bulletin, vol. xxxi, Nos. 351-5, August-September, 1920.

fee or ticket. All the courses, with one exception, are given by teachers in London medical schools; the one exception is the lecture to be given on June 8th at the house of the Royal Society of Medicine by Dr. H. J. Hamburger, Professor of Physiology in the University of Groningen; the lecture will deal with "permeability in physiology and pathology," and Professor E. H. Starling, C.M.G., F.R.S., will be in the chair. On June 13th Professor F. R. Fraser will begin a course of four lectures at St. Bartholomew's Hospital on digitalis: the first will deal with the principles of the therapeutic use of the drug; the second with its use in the cardiac arrhythmias; and the third with its effect in cases with normal cardiac rhythm; in the fourth lecture digitalis glucosides and allied substances will be described. Four advanced lectures in pharmacology will be given at the Royal College of Surgeons by Dr. Edward Mellanby, Professor of Pharmacology in the University of Sheffield, on June 6th, 7th, 13th, and 14th. The first two lectures will deal with elements of diet aiding and preventing the proper calcification and growth of bones and teeth, and the third with dietetic conditions affecting the development of normal and hyperplastic thyroid glands and the application of the experimental results obtained to exophthalmic goitre. In the fourth alcohol as a food-drug will be discussed. A course of four lectures on recent advances in experimental embryology will be given at the Imperial College of Science, South Kensington, by Dr. E. W. MacBride, F.R.S., Professor of Zoology in the College. The first lecture will be given on June 7th; in it Professor MacBride will discuss the nature of the process of fertilization, artificial parthenogenesis and allied matters; in the second he will deal with the three stages in a normal life-history and the dependence of the formation of organs on the "internal environment." This subject will be continued in the third lecture, which will contain a review of the effects of thyroid extirpation and of thyroid feeding on tadpoles, of the relation of the pituitary to growth in tadpoles, and an analysis of the effects of the thyroid, as seen in Axolotl and perennibranchiate Urodela. The effects produced by the external environment as worked out by Kammerer will then be described, and, finally, the bearing of the results on the theory of evolution will be discussed. Dr. Charles Porter, M.O.H. St. Marylebone, will begin a course of four lectures on recent developments in legislation for the prevention of disease, at University College, Gower Street, on May 30th. The first lecture will deal with the history of the subject, the second with directly preventive legislation, the third with indirectly preventive legislation, and the fourth with legislation of the future. The lectures are given at 5 p.m., except those of Dr. Porter's course, which will be given at 5.30 p.m.

PROTECTION OF RADIOLOGICAL WORKERS.

THE X-Ray and Radium Protection Committee, to the proposed formation of which we made reference a few weeks ago, has now been constituted; it has been established to investigate the means of protecting workers with x-rays and radium from the injurious effects which have been observed, especially those on the skin and blood. The Chairman is Sir Humphry Rolleston, K.C.B., M.D. The members are: Sir Archibald Reid, K.B.E., C.M.G., Radiologist to St. Thomas's Hospital; Dr. Robert Knox, Radiologist to King's College Hospital and the Cancer Hospital (representing the British Association for the Advancement of Radiology and Physiotherapy); Dr. S. Gilbert Scott, Radiologist to the London Hospital; Dr. Stanley Melville, Radiologist to St. George's and to the Brompton Chest Hospitals (representing the Electro-therapeutic Section of the Royal Society of Medicine); Dr. Harrison Orton, Radiologist to St. Mary's Hospital; Mr. Cutlbert Andrewes (representing the Röntgen Society); Professor S. Russ, Physicist to Middlesex Hospital (repre-

sented the Institute of Physics); Dr. G. W. C. Kaye, O.B.E. (representing the National Physical Laboratory); Dr. J. C. Mottram, Pathologist to the Radium Institute. Dr. Melville is acting as honorary secretary. The Committee held a preliminary meeting on May 18th at the house of the Royal Society of Medicine. The Committee has appointed a subcommittee to draw up a short statement on the means for the protection of the worker, giving advice as to the position of x-ray rooms, their ventilation and cubic space, and on the need for making and observing rules governing the hours of work, outdoor exercise, and holidays of workers. It is hoped that this statement may shortly be issued as a leaflet. The Committee intends further to collect data bearing on the effect of irradiation with particular reference to protection; to carry out special research, if necessary; to act in a consultative and, possibly, advisory capacity; and to publish reports from time to time.

RESEARCH IN RADIO-THERAPEUTICS.

A SCHOLARSHIP has been founded at the Manchester Royal Infirmary primarily for the investigation of the claims made, especially in Germany, for the intensive x-ray treatment of cancer. The anonymous donor, however, desires that the inquiry shall include the study of the cancer problem from any point of view that may arise, and also an inquiry into the precautions that should be taken for the protection of persons working with highly penetrative rays. The scheme under which the scholar will work has been framed by a committee, consisting of Sir William Milligan, Professors H. R. Dean and W. L. Bragg, Dr. A. Burrows, Dr. Powell White, Mr. James Watts, and Dr. A. E. Barclay. Dr. C. C. Anderson has been appointed the first scholar, and will visit various centres where the intensive method is in use. He will then return to Manchester to carry on the investigation in collaboration with other workers, who will attack the problems arising from the pathological and physiological standpoints. It is intended that the first visit should be made to Erlangen, but if time permits the scholar will afterwards visit Freiburg, Berlin, and Mannheim, and certain centres in France, Holland, and Sweden.

COLONEL WILLIAM HUNTER, C.B.

ON Friday, May 20th, at the Imperial Restaurant, a complimentary dinner was given to Colonel William Hunter, C.B., M.D., in recognition of his scientific work, especially in regard to preventive medicine. It was felt by his colleagues and professional friends that Dr. Hunter's retirement from the active staff at Charing Cross Hospital formed a suitable occasion to express their appreciation both of himself and of his work. The dinner was presided over by Mr. George Verity, chairman of the governing body of Charing Cross Hospital, who was supported, in addition to the other speakers, by Sir Arbuthnot Lane, Sir Frederick Mott, Sir Herbert Waterhouse, Mr. Walter Spencer, and a large company. The chairman spoke of the affection and admiration felt for their guest by all who knew him. He referred, with a layman's diffidence, to some of the landmarks in Dr. Hunter's career—his researches in diseases of the liver, his discovery of the importance of oral sepsis, his labours in freeing the Serbian army of typhus, and his work as President of the War Office Advisory Committee for the prevention of epidemic diseases in the Eastern war areas—and expressed the regard felt for him by all who had been associated with him during his many years' service at Charing Cross as Physician and Dean, and also as historian of the Hospital and Medical School. Sir Thomas Barlow said that a man who had done what William Hunter had done should be told by his friends and colleagues what they thought of him, and of his gift to humanity. In his pioneer work on pernicious anaemia, its prevention and arrest, he took the true scientific line;

he grappled first of all with causation, knowing that treatment would follow from study of the natural history of the disease. In attacking the problem of typhus in the East, he concentrated his efforts on lice, the carriers of infection, applying fresh knowledge to new and difficult conditions. They were proud to think that all this work had been done by a general hospital physician. Dr. William Hunter, in replying to the toast of his health, made a modest and charming acknowledgement of the tribute paid him by his old friends and colleagues. He expressed the regret with which he gave up his work at Charing Cross after a quarter of a century. Touching briefly on his war experiences between April, 1915, and December, 1919, he spoke of the loyal support given by his bacteriological colleagues and his good friends the Serbians in overcoming typhus. As he read it, the lesson of his war work was that prevention must be grasped as a whole. Sir James Galloway, in proposing the toast of "The Visitors," added a word of genial appreciation of "Willie Hunter" on behalf of the staff of Charing Cross. This note was echoed by Sir William Hale-White, who said that praise from the brethren of one's own profession, those who knew and understood, was the only praise worth having. Sir Humphry Rolleston, who also responded, preferred to regard himself as an honorary host rather than as a visitor. For very many years he had admired the whole-minded way in which their guest pursued his aims, and these included all branches of preventive medicine. The health of the Chairman was proposed by Sir John Bland-Sutton, who sketched in bold outline the qualities needed for a good hospital chairman, and in so doing described Mr. Verity.

THE AMERICAN MEDICAL ASSOCIATION.

THE annual meeting of the American Medical Association takes place this year at Boston, Massachusetts, from June 6th to June 10th, and it is expected that nearly 10,000 persons will visit Boston in connexion with the meeting. Special trains and special railway fares from all parts of the United States have been arranged for members of the Association who are attending. The different scientific sections are to meet on June 8th, 9th and 10th. The Sections on the Practice of Medicine; Obstetrics, Gynaecology and Abdominal Surgery; Laryngology, Otolaryngology and Rhinology; Stomatology; Pathology and Physiology; Nerves and Mental Diseases; Urology; and Preventive Medicine and Public Health will hold their meetings during the mornings. The Sections on Diseases of Children; General and Abdominal Surgery; Ophthalmology; Miscellaneous Topics; Pharmacology and Therapeutics; Orthopaedic Surgery; Dermatology and Syphilology; and Gastro-enterology and Proctology will meet during the afternoons. On June 6th and 7th a series of special clinics have been arranged in the Boston hospitals. In connexion with the scientific exhibition, it has been suggested that many subjects presented before the sections in papers could, if there were time and opportunity, be demonstrated by specimens, material, instruments, apparatus, charts and the like, or by lantern slides, or "moving picture talks," and it is proposed that the authors should be encouraged to supplement their papers with exhibits. If the exhibit is movable it may be taken to the meeting place of the Section at the time of the reading of the paper, and then returned to its place in the Exhibit Hall. The exhibits have been arranged in three main divisions—medicine, surgery, and pathology. It is pointed out that "still" exhibits are of little value; what is desired are personal demonstrations or explanatory talks by someone who is interested in, and can teach, the subject. The *Journal of the American Medical Association* remarks that the primary object is to bring to the minds of the profession attending the meeting a knowledge of the newer things in the progress of scientific medicine, and thus not to limit the presentation of such subjects to the comparatively

small groups of physicians or surgeons attending a particular section. In addition to the scientific work which is to be carried on at the Boston session there are many social features, while the fact that the Pilgrim Tercentenary takes place at Plymouth (U.S.A.) immediately after the close of the scientific meeting suggests that it will be attended by many members of the association.

MEDICAL INSURANCE AGENCY.

A MEETING of the Committee of Management of the Medical Insurance Agency was held at the house of the British Medical Association, 429, Strand, on May 12th, when the chairman, Dr. G. E. Haslip, presented a report on the working of the agency for the year 1920. There had been, he said, substantial progress in all classes of insurance, including a large increase in the life business. Special pains were taken to arrange policies of life insurance suitable to the needs of medical practitioners. Children's policies, either in the form of thrift policies or educational endowments, appealed, it was found, strongly to the profession. Business in motor car insurance was done both with the tariff offices and in respect of a special doctor's policy granted by Lloyds' underwriters. Though the amount of business was satisfactory, it was felt that it might easily be larger were the advantages offered by the agency better known. During the year the sums returned by way of rebate to those holding policies of various kinds through the agency amounted to £1,453, or £493 more than in 1919. This is a direct saving to the insured, and since the agency was founded, in 1907, the sums saved to the profession have amounted altogether to well over £9,000. The expenses of the agency show an increase of £158, due in part to the increased cost of printing, postage and stationery, and in part to the salary now paid to the clerk to the agency. After allowing for the rebates and agency expenses the balance-sheet, certified by the auditors, Messrs. Price, Waterhouse and Co., shows a surplus available for distribution among medical charities amounting to £1,959. At intermediate meetings held in May and December, 1920, grants amounting to £1,015 were made to medical charities, leaving an unallotted balance of £976. It was now resolved to make grants of 300 guineas each to the Royal Medical Benevolent Fund, the Royal Medical Benevolent Fund Guild, and Epsom College Benevolent Fund. The objects these who founded the agency placed before themselves were, first to assist medical men to insure against various risks on the best possible terms, and secondly, to use part of the commission earned by the agency to help medical charities. Both objects have been attained. As a result of the distribution this year the total sum paid to medical charities by the agency since its foundation is £7,380. Mr. W. E. Warne, who has been agent and secretary since the death of Mr. Guy Elliston (who was one of the founders), is retiring, but the agency will continue to have the advantage of his experience, as he has accepted a seat on the Committee of Management. Mr. P. N. Adamthwaite, who has worked in the office of the agency for some years, has been appointed agent.

THE BIRTH OF EDWARD VI.

CAESAREAN section takes its name, of course, from the reputed birth in this manner of Julius Caesar, but the operation is of still more ancient origin. Pliny, in mentioning it, says that Scipio Africanus (B.C. 237) was so born, as, according to Ovid, was Aesculapins. There is in England a persistent tradition, supported by contemporary ballads, that Queen Jane Seymour, the third queen of King Henry VIII, was delivered by Caesarean section of the prince who became King Edward VI. The story is told, and the evidence sifted, in an interesting article by Dr. S. D. Clippingdale, in the spring number (Vol. xxviii, No. 1, New Series) of the *Journal of Obstetrics and Gynaecology of the British Empire*, although he arrives at no definite conclusion as to the truth or otherwise of the tradition. Queen Jane was approaching her thirtieth

year when the confinement occurred, on October 12th, 1537, at Hampton Court, and she died twelve days later. There is a story, not unsubstantiated, of how when it was explained to him that, owing to the protraction of the labour, an operation was necessary—the choice apparently lay between craniotomy and Caesarean section—the King replied: "Save the life of the child, for another wife can easily be found." This sentiment may have been influenced by State policy, but it does not to modern ears compare favourably with Napoleon's in like case: "Save both lives if you can, but if you cannot save both lives, save the life of the Empress." Early on the day of her death a certificate was sent to the Privy Council, signed by three apothecaries and three Court physicians, reporting that "Yesterday afternoon she"—the Queen—"had a natural lax for reason whereof she began to lighten"—this perhaps indicates the presence of peritonitis—"and (as it appeared) to amend and so continued till towards night. All this night she hath been very sick and doth rather appare than amend." There is no mention of operation in this report or in a letter which the Queen addressed to the Privy Council, two days after her confinement, to announce the birth of a prince, and evidently the Queen progressed well for at least a week, when her condition took an unfavourable turn. Dr. Clippingdale suggests that on the removal, after eight or ten days, of the wrappings with which the patient had been swathed, septic peritonitis may have been induced. Whatever was the actual cause of death, however, the popular belief, as shown by the ballads quoted in the article, was undoubtedly that it resulted from Caesarean section.

TUMOURS AS MALFORMATIONS.

In a thoughtful article with the non-committal title "Studies on tumour formation," Dr. G. W. Nicholson,¹ Lecturer in Morbid Histology at Guy's Hospital, first exposes the weak points in the current definitions of a tumour, and then asserts that the reason why these definitions break down is that tumours do not differ in any essential character from the other tissues of the body. He maintains that it is only by regarding tumours as aborted organs that their structure, growth, and development can be understood; there is, he argues, no distinction between tumours on the one hand and accessory organs or malformations on the other; thus he holds that the nature of a mammary fibro adenoma is more truly expressed by terming it "a malformed breast," that "giant parathyroid" is quite as good a description as parathyroid adenoma, and that a secondary squamous-celled carcinoma would be more accurately described as "malignant skin." Reversion to the appearances seen during the development of the tissues is a characteristic feature of most tumours; thus the malignant "adeno-sarcoma" of the kidney, not uncommon in early life, habitually recapitulates the normal development of that organ and was rightly entitled "malignant embryonic kidney" by Trappe. To the phenomena characterizing malignancy Dr. Nicholson proposes to devote a future article, and to this we shall look forward, for, after all, the point that chiefly interests the bulk of the profession is how to obviate the harmful effects of tumours, whatever their exact nature may be, and, if possible, to substitute prevention for problematic cure. But to return to Dr. Nicholson's argument: it is often urged that tumours do not perform any function, or, if so, that it is useless; there are, however, many examples with histological evidence of considerable physiological activity in tumours, especially those in connexion with secreting glands; tumours, in fact, do their best in this direction, but as abortive organs, often without ducts, they fall short of success. To define a tumour as autonomous and deriving its nourishment from the body does not

distinguish it from an organ such as the liver or from the foetus *in utero*. Dr. Nicholson therefore concludes that in their structure, manner of growth, and functions tumours do not differ essentially from other tissues; they are merely less perfect; they merge into, and indeed are, malformations. Incidentally, Dr. Nicholson declares war on the term "endothelioma" as a convenient category for tumours of difficult classification, and expresses repentance for having described six examples in 1907.

THE ANNUAL MEETING AT NEWCASTLE.

THE provisional programme for the forthcoming annual meeting of the British Medical Association at Newcastle-upon-Tyne was printed in last week's SUPPLEMENT, together with further particulars regarding accommodation for visitors at Newcastle. Later issues of the SUPPLEMENT will contain the revised programme of arrangements and forms for notification of attendance to be filled in by members intending to be present at the annual meeting. The title of Sir Thomas Oliver's special address on industrial medicine, to be given on Wednesday, July 20th, at 8 p.m., is "Industrial Hygiene; its Rise, Progress and Opportunities." The lecture will be open to those of the commercial and industrial classes who are interested in the subject.

THE MEDICAL CURRICULUM IN GERMANY.

IN an opening address delivered to the German medical congress which met in Wiesbaden last month, Professor G. Klemperer of Berlin expressed the view that the economic disabilities under which Germany was labouring—disabilities which were likely to continue—would make it necessary to shorten the medical curriculum. He suggested that in future it would be possible to allot only four terms to what are called in this country the preliminary and intermediate subjects—physics, chemistry, anatomy, and physiology. Six terms, he thought, would be required for the clinical subjects. During the first year of clinical study a medical student should attend a course of practical nursing, and during the two following clinical years should be engaged in practical work in the various hospital departments. After condemning the too great length of vacations, he maintained that by replacing technical and theoretical studies by intensive practical work it would be possible to give up the "practical year" hitherto required after the passing of the final qualifying examination. Under existing economic conditions, he said, the recently qualified student could not afford to spend a year in unremunerative hospital work; this requirement, moreover, was a serious obstacle to early marriage. Turning to more general questions, Professor Klemperer laid stress on the absolute necessity of maintaining free choice of doctor. The relation of doctor to patient was strictly personal, and State control would destroy the highest ideals of the medical profession. Finally, he had a fling at women doctors; he had, he said, no objection to them in theory, but doubted profoundly whether their physical strength would be equal to the exacting demands of medical practice.

DANGEROUS DRUGS REGULATIONS.

THE Regulations, dated May 20th, 1921, made by the Secretary of State for Home Affairs, under Section 7 of the Dangerous Drugs Act, 1920, are published in the *London Gazette* of May 24th, but the Report of the Committee which has been advising the Home Secretary on these Regulations is not yet available. We hope to deal with the Regulations and the Report next week.

LORD CAVE'S committee of inquiry into the finances of the voluntary hospitals has held meetings again this week, but it is not expected that the report will be completed for presentation before the end of the month.

¹ G. W. Nicholson, *Guy's Hospital Reports*, 1921, vol. lxxi, pp. 222-246. London: H. Frowde, and Hodder and Stoughton, 1921. (Med. 8vo, pp. 132-251. 12s. 6d., or 42 2s. per vol. of four numbers.)

Scotland.

ROYAL EDINBURGH HOSPITAL FOR SICK CHILDREN.

SIR JOHN R. FINDLAY, who presided at the annual meeting of contributors to the Royal Edinburgh Hospital for Sick Children, said, in moving the adoption of the annual report, that the expenditure had increased by leaps and bounds, and although the public had responded by increasing their subscriptions the increase was below the increase in expenditure. The hospital had always had to draw upon benefactions in the form of legacies, but the percentage met from this source had gone up at the present time to between 41 and 45 per cent. Edinburgh was perhaps more fortunate than London, where there was a large number of competing hospitals, with comparative lack of personal interest on the part of the public in any particular hospital. Scotland, however, was divided into comparatively small districts, and the inhabitants of these particular districts took a pride and a personal interest in the hospitals which, he thought, would enable them to maintain the voluntary system much longer than elsewhere. What they might hope for was that if any assistance was given to the voluntary hospitals it would not be in a form which would have the effect of undermining the voluntary system. Colonel Newbigging seconded the adoption of the report, which was agreed to. Lord Ashmore, in moving a resolution commending the hospital to the liberality of the public, said that he was struck by the fact that there was a kindly appreciation of the institution on the part of many of the public works, and of one or two of the large co-operative societies.

EDINBURGH UNIVERSITY ROLL OF HONOUR.

It is a melancholy business for the survivors of a generation to peruse the memorial of their fellows who are dead, even though their deaths were glorious and deserving of memory. As we turn over the pages of this volume,* recognizing so many names and so many faces of student days before the war, we realize more poignantly the blight that has been cast upon a whole generation. So many are dead without our having known it, so many are dead whose deaths we knew too well. Edinburgh has always prided herself on being a university for all the world, and on the long roll appear names from every corner of the globe, and from Highland parish schools as well as from Eton and Winchester. Young and old are there together, from the fresher of one term's standing to Sir Hay Donaldson, who was 60 when he was drowned with Lord Kitchener, and Colonel James Clark, K.C., who was killed in action in France at the age of 56. The names of two ladies, both medical graduates, appear—Dr. Elsie Inglis, who died as the result of her memorable work in the Balkans, and Dr. Marian Wilson, who died at Royaumont, in France. The names of famous athletes one expects to find on such a roll as this, but with them in equal honour are the names of men whose field was the laboratory or the study. So, with Bedell-Sivright—the dashing forward of twenty-two internationals—J. L. Huggan, Eric Milroy, Alfred Taylor, J. H. D. Watson, and many another, we have A. D. Darbishire, the brilliant university lecturer on genetics, who was a private in a Highland regiment before he gained a commission in the Artillery, John Handyside, the lecturer on logic and metaphysics, and H. H. Norton, the Wesleyan minister who as an R.A.M.C. private was killed at Gallipoli. There, too, are W. G. Porter—who gained a D.S.O. as an Artillery major—and Denis Cotterill, the surgeons, and G. H. Melville Dunlop, the physician, who would to-day so surely have been carrying on in Edinburgh the tradition of the medical school, while among the undergraduates who have fallen are the honoured names of Bayley Balfour, Cathcart, and Schafer.

On the Roll of the Fallen appear the names of 944 members of the university, with brief accounts of their academical and military careers, illustrated in nearly all cases by photographs, while in the Record of War Service are some 7,000 more names. At first, we believe, it was intended that this Record should include all forms of

national service, but various difficulties arose, and as it was realized that such services stood in a different category from services in the field the intention was abandoned. It may be regretted, however, that for this reason the names are excluded of the Edinburgh graduates who held high office in the State during the war, while the names are included of some honorary graduates—such as General Botha and Sir Alfred Keogh—who otherwise had little connexion with the University. At the end of the volume is a list of the orders and decorations won by members of the University, including five Victoria Crosses. Although none of the five are medical men, two had been medical students. The volume, which is sumptuously produced, has been edited by Major John E. Mackenzie, who was adjutant of the University Officers' Training Corps throughout the war, and who has pursued an arduous task to a most successful end.

We print below the names of the medical graduates of the University who are included in the Roll of the Fallen:

Captain J. G. Anderson, M.C., Colonel J. H. E. Austin, Dr. A. K. Baxter, Dr. Guy Beattie, Fleet Surgeon D. R. Bedell-Sivright, Colonel C. M. Begg, Captain J. H. Beilby, Captain J. A. T. Bell, Captain T. H. S. Bell, Captain J. W. Bingham, Captain H. W. Binks, Surgeon-General W. G. Birrell, Captain E. J. Blair, M.C., Captain G. S. Blandy, M.C., Captain G. V. Bogle, Captain G. S. Brock, Captain W. Brownlie, M.C., Lieutenant J. E. Brydon, Captain W. H. Calvert, Lieutenant D. Campbell, Lieutenant J. Cattanaach, Fleet Surgeon W. R. Center, Captain S. McA. F. Cesari, Captain J. J. P. Charles, M.C., Lieutenant A. L. Christie, Captain I. A. M. M. Clarke, Captain D. Cotterill, Captain A. Cowe, Captain T. F. Craig, Lieutenant J. Crocket, Captain D. C. Crole, Lieutenant M. W. Danzig, Captain J. Davie, Captain R. H. Drennan, Major C. W. Duggan, Captain R. W. Duncan, Major G. H. Melville Dunlop, Captain J. J. Dykes, Major E. J. Elliot, Surgeon W. Evereff, Captain G. D. Ferguson, D.S.O., Colonel C. C. Fleming, D.S.O., Major E. G. Ford, Captain J. D. Forrester, Captain J. W. Frew, M.C., Lieutenant N. M. Gavin, Lieut.-Colonel W. A. Gibb, Captain W. E. Gibbons, Captain D. Gilmour, Captain E. M. Glanvill, Major R. G. Gordon, D.S.O., Captain J. P. Grant, Colonel B. B. Grayfoot, C.B., Lieutenant R. D. L. Greene, Captain A. Groeneveld, M.C., Lieutenant G. W. Guthrie, Captain T. E. Guthrie, Captain F. Hardie, Lieut.-Colonel N. E. J. Harding, Major A. C. Hartley, Captain T. Hayhurst, Lieutenant F. G. Heard, Captain J. H. Helm, Captain N. J. Holmejr, Lieut.-Colonel M. Holmes, Staff Surgeon A. O. Hooper, Surgeon H. J. Hopps, Second Lieutenant S. C. Huddleston (Black Watch), Lieutenant J. L. Huggan, Captain G. S. Husband, D.S.O., Colonel J. Hyslop, D.S.O., Lieutenant C. C. Iles, Dr. Elsie M. Inglis, Captain M. P. Inglis, Major R. C. Irvine, Lieut.-Colonel T. W. Irvine, Captain A. Jasnowsky, Major F. N. Johns, M.C., Major F. M. Johnson, Captain G. E. Keith, Lieut.-Colonel M. A. Ker, Captain S. A. Kuny, Captain E. W. Lawrence, Major H. Ruthven Lawrence, M.C., Captain G. M. Levack, Surgeon C. W. Lewis, Captain D. P. Lindsay, Captain S. J. Linzell, M.C., Croix de Guerre, Captain A. G. S. Logie, Captain A. P. Low, Captain H. T. Lukyn-Williams, Lieutenant G. H. Lunan, Surgeon H. J. McCaw, Captain L. T. McClintock, Lieut.-Colonel W. McConaghy, D.S.O., Surgeon J. S. D. McCormack, Captain J. Macdiarmid, Captain I. Macdonald Brown, Captain R. G. McElney, M.C., Captain I. Macfarlane, Major J. G. Macindoe, Captain J. A. MacKenzie, M.C., Surgeon D. S. MacKnight, Captain I. Keith-Falconer MacLeod, Captain A. Macnab, Second Lieutenant R. D. M. Macpherson (Seaforth Highlanders), Captain P. C. Macrae, Major W. A. Malcolm, Lieutenant J. Marshall, Major A. A. Martin, Captain J. McD. Matheson, Colonel H. G. Melville, C.I.E., Lieut.-Colonel A. J. A. Menzies, D.S.O., Lieutenant G. H. Middleton, Staff Surgeon G. R. Mill, Lieutenant A. I. Miller, Captain R. Montgomery, Surgeon G. B. Moon, Colonel A. H. Moorhead, Surgeon A. A. Morison, Major J. Morris, M.C., Captain S. H. Morris, Captain W. Morrison, M.C., Captain K. K. Mukerji, M.C., Lieutenant J. S. Munro, Dr. T. Nelson (St. John Ambulance Brigade), Lieutenant R. F. T. Newbery, Major F. W. Nietzsche, Captain J. D. Noble, Captain J. McC. Orme, M.C., Captain H. S. Palmer, Captain P. Pattison, Lieutenant A. Philip, Captain A. Z. Philips, Captain G. S. Pirie, Major W. G. Porter, D.S.O. (R.F.A.), Captain O. D. Price, Dr. E. F. T. Price, Captain H. H. Proudfoot, Captain A. M. Pryce, Captain W. D. Reid, M.C., Lieut.-Colonel J. C. Renton, Captain H. Rendell, M.C., Lieutenant M. J. Richardson, Major W. R. Ridley, Captain W. Ritchie, Captain A. B. Robertson, Captain R. C. Rogers, Lieut.-Colonel A. A. Ross, Lieutenant A. B. Ross, Lieut.-Colonel C. S. Rundle, Dr. J. F. Selkirk, Lieutenant J. W. Senter, Major M. C. C. Sefon, Captain J. J. Shannon, Lieutenant J. G. Sharp, Captain J. C. Simpson, Lieutenant D. W. Sinclair, Captain C. E. H. Smith, Captain H. G. Smith, Captain H. M. Spoor, M.C., Surgeon A. R. Steel, Major N. W. Stevens, Lieut.-Colonel W. M. Sturrock, Major W. Symington, Colonel F. A. Symons, D.S.O., C.M.G., Captain A. S. Taylor, Captain H. Y. C. Taylor, Captain C. Templeman, Major B. C. Tennent, M.C., Major F. G. Thatcher, M.C., Lieut.-Colonel F. W. Thomson, Lieutenant A. L. Thornley, Captain J. J. Tough, Surgeon S. N. Tomlin, Surgeon A. E. Turbull, Captain J. K. Venables, M.C.,

* *University of Edinburgh Roll of Honour, 1914-1919.* Edinburgh and London: Oliver and Boyd, 1921. (Cr. 4to, pp. 797; 99 plates. 40s. net.)

Surgeon-Lieutenant F. L. J. M. de Verteuil, Lieutenant J. T. Waite, Captain G. Walker, M.C., Captain A. Wallace, Captain R. N. Wallace, Surgeon J. S. Ward, Lieutenant D. G. Watson, Surgeon J. H. D. Watson, Captain W. N. Watson, M.C., Captain H. D. Weply, Captain T. Welsh, M.C., Major A. Westlake, Captain J. Wilson, Captain J. Dykes Wilson, Dr. Marian E. Wilson, Lieut.-Colonel R. E. Wood, Major J. Woods.

Correspondence.

BLOOD TRANSFUSION IN HAEMORRHAGIC DISEASE OF THE NEWBORN.

SIR,—In your issue of April 9th, 1921, p. 527, Mr. Douglas Laurie cites a severe case of melæna neonatorum successfully treated by blood transfusion. It should be realized more generally that blood transfusion, if used in time, is an absolute remedy for these cases of hæmorrhagic disease of the newly born. In a few cases horse serum or human blood injected subcutaneously may be used successfully, but to ensure a cure blood transfusion is beyond any question the best and most reliable procedure. In the Hospital for Sick Children, Toronto, we prefer the syringe cannula (Lindeman) method,¹ but where this is not feasible the citrate method may be used.

The freshly introduced blood not only stops further bleeding, but replaces the lost blood. We consider the cure of the hæmorrhagic condition to be accomplished practically at the end of the transfusion. The amount to be given varies with the weight of the infant, but a good working rule is not to exceed 15 c.cm. per pound of body weight. The transfusion is completed usually in ten to twelve minutes, the actual time of injection being about three to four minutes for 100 c.cm. of blood.

Mr. Laurie lays too great emphasis on the difficulty of exposing a suitable vein and in having to use a hypodermic needle to inject the blood. This difficulty is very readily overcome by exposing under local anaesthesia the internal saphenous vein where it crosses the internal malleolus. If this vein cannot be seen, it can usually be palpated and feels like a small vas deferens when rolled under the thumb-nail. If it cannot be located before cutting down, it can be exposed by an incision which crosses its course. This vein is much thicker walled than the elbow veins and is more constant in its position. Small, sharp-pointed, curved eye or manœuvre scissors are used to make an oblique cut in the vein after applying and steadying the vein with a distal ligature. The lumen is dilated with the tips of the scissors. It is surprising how large a cannula this vein will accommodate, and I use a 1½ in. No. 17 tempered, gold serum needle with the point (but not the bevel) rounded off. A 2 in. rubber tube, armed with metal tip fitting the hub of the needle, makes the injection of blood simple.

Following transfusion, if the bleeding has been from the bowel, old dark blood is passed during the first twenty-four hours. The necessity of obtaining a compatible donor is not as great as in the case of older children or adults, as in many of the infants we have found that the agglutinins are not established at birth, or if so, are apparently weak. When the father is the only donor available, I have used him without preliminary grouping tests. If circumstances permit of it, it is safer to have a compatible donor or a universal donor (Group IV, Moss grouping) as Mr. Laurie did.

In a series of 40 cases of hæmorrhagic disease of the newly born transfused at this hospital and elsewhere, four died, two of these from associated sepsis of the umbilical cord and one from intracranial hæmorrhage, which was extensive before transfusion. The fourth case had bled profusely for two days, and had stopped breathing half an hour prior to admission to hospital. During that time artificial respiration had been carried out, and although the pulse was present on admission, the patient was too far gone to benefit by transfusion.—I am, etc.,

BRUCE ROBERTSON.

Assistant Surgeon, Hospital for Sick Children,
Toronto, Canada.

April 29th.

¹Bruce Robertson: The Transfusion of Whole Blood. BRITISH MEDICAL JOURNAL, 1916, vol. ii, p. 38.

HEART-BLOCK AND THE ADAMS-STOKES SYNDROME.

SIR,—In a letter published in your last issue (p. 755) Sir Clifford Allbutt gives the pathological findings of a case which exhibited the Adams-Stokes syndrome, but nevertheless showed an apparently healthy myocardium.

I am afraid the report of my paper read before the members of the Liverpool Medical Institution was not sufficiently explicit. My opinion was based not on pathological but on electro-cardiographic evidence. My personal experience of these cases is as follows:

Cases of block, complete and partial, which, apart from the lesion of the *a-v* bundle, gave a perfectly normal cardiogram, never exhibited the Adams-Stokes syndrome. In complete block these cases show a slow but a regular pulse rate. On the other hand, so far as my experience goes, cases which have exhibited Adams-Stokes syndrome have shown some aberration in the Q.R.S. complex—snob, for instance, according to Lewis, were evidence of a defect in one of the branches of the *a-v* bundle. Apart from the disturbance of the conductivity of the main bundle there was evidence that other structures of the heart were affected.

The impression one gains from such cases is that the defect in the main bundle is really not the primary lesion, and that, on the contrary, some degenerative changes starting elsewhere have gradually affected this structure. Accordingly more often than not the degree of block is not very pronounced in such cases. But the degenerative changes of the heart muscle must be extensive in them, since not only the main bundle but one of the branches is affected. Moreover, clinically the prognosis of cases exhibiting these aberrations is very grave, if we except those instances in which the defect is due to some removable cause, such as syphilis.

But the interesting feature of these cases which has a bearing on Sir Clifford Allbutt's letter is the pathological findings. Although the gravity of the clinical symptoms must lead to the assumption of the presence of extensive pathological changes, yet a *post-mortem* examination in many instances revealed scarcely a pathological lesion (Lewis and others).

But to return to our main theme: I do not wish to be misunderstood. I do not say that the Adams-Stokes syndrome does not appear under any other circumstances than in cases which show this particular aberration. What I maintain is this: A lesion limited to the main *a-v* bundle does not give rise to an Adams-Stokes syndrome. In cases which exhibit this syndrome in addition to the defect in the main bundle some other factor comes into play. It is conceivable that in a damaged heart muscle the refractory period of the ventricle may become longer than normal after a temporary exhaustion, or a structure might become affected which is the seat of the origin of the ventricular rhythm.

Clinically and pathologically, cases exhibiting the syndrome show so many different features from ordinary heart-block that they ought to be treated as a separate entity. Ordinary block is a disease with a clean-cut pathology and a definite clinical picture. On the other hand, a great deal of work will still have to be done before the cardiac mechanism which produces the syndrome becomes clear. Evidently Sir Clifford Allbutt's case belongs to a great number of heart cases in which the present pathological methods are inadequate to discover subtle changes in some vital structure, which, in accordance with clinical evidence, must be in existence.—I am, etc.,

Liverpool, May 20th.

I. HARRIS.

THE PREVENTION OF PUERPERAL INFECTION.

SIR,—As a general practitioner of twenty-seven years' experience, I feel bound to make comments upon Dr. Blair Bell's very able paper printed in the BRITISH MEDICAL JOURNAL for May 14th.

The use of gloves in midwifery, with many other men, I deprecate: they diminish the tactile sensibility of the fingers, they lead to inevitable carelessness, and the hands are clumsily washed because the accoucheur feels that they are going to be covered and it matters not. The result is that the left hand, still infected, presses on the fingers of the right glove and they are fouled. It is considered unnecessary to dip the gloves in an antiseptic; therefore, if there

be any infectious material about the vulva it is carried into the vagina without any inhibitor.

Consider, then, the conditions of an ordinary confinement. A small room with one nurse, who has to give the chloroform! Almost inevitably the patient must be moved or non-sterilized articles touched. In a nursing home or a hospital this is not necessary, but very few of the 800,000 births each year occur in hospital. No! Teach the men to wash their hands in mercury biniodide, and little else matters. When I was "charity" at Guy's Hospital twenty-five years ago and whilst I was house-surgeon such a thing as puerperal fever was never considered—it did not occur.

The unskilled students were soaked in perchloride, and yet they examined the patients continually for hours and hours. The universal experience, as far as I have heard it, is that the cases that have fever are those where little has been done and that those where there has been great interference escape infection. There is a tendency to-day to accept too readily the dicta of the aseptic people. Antiseptics are urgently required and produce brilliant results, as the experience at Guy's and other great hospitals illustrates. Even surgeons operating do not wash their hands as they did in the old days, so that frequently their gloves are infected, as their fingers, unclean, escape through holes torn in the gloves. Sterilized aprons are very charming, but dangerous. A man says they are clean, and will touch them, but the mischief has been done—the apron has touched the bed. He will not dream of touching his clothes; he feels and knows that they are dirty. After a widespread though numerically small experience, I say: Teach the accoucheurs to wash and to use mercury biniodide for everything. The present use of a few drops of lysol is useless and dangerous, because the accoucheur depends on it. There must be a bowl of biniodide 1 to 1,000 in which he can dip his hands every few minutes.—I am, etc.,

London, S.W., May 17th.

VAUGHAN PENDRED.

Sir,—In your leading article you say, "Many a woman would escape infection if the attendant only arrived as the child was passing over the perineum, so that no vaginal examination could have been made." This was exactly what happened in one of the only half-dozen or so cases of puerperal infection it has been my lot to see in thirty years of general practice. I have been in a rural practice twenty-eight years, and before that I was two years in colliery and town practice. I am perfectly certain not more than half a dozen cases of puerperal infection have been seen by me in some 1,400 odd cases of midwifery. Perhaps I ought to be ashamed to admit I have never possessed a pair of rubber gloves, nor worn a pair at a confinement, and only twice seen the vulva shaved—much to the disgust of the patients, who swore they would never allow it again. Up to a year or two ago I never hesitated to make as many vaginal examinations as I liked, just to see how the labour was progressing, and never saw any harm come of it. Forceps have been employed in about 12.5 per cent. of my cases, which include one craniotomy and many where turning was required, and so far as I can remember no case of infection occurred after any bad case, except a few cases of phlegmasia alba dolens. The main point I wish to emphasize is that I have not seen a death from puerperal infection of any kind. The most serious cases of infection that have come my way have followed abortion—incomplete abortion, of course—and although I have seen many of these and some very ill, I have not seen a death. I think I can see a parallel between infection after abortion and infection after delivery at term.

It has struck me often that some of these patients ought to have become badly infected, for many a time I have seen shreds of putrid membrane passing out of the vagina after what was regarded as a perfectly normal labour, yet all went well with ordinary treatment, which consisted of keeping the vagina clean. I believe there is sometimes far too much meddling with the interior of the uterus, and if activities there were confined to simple douching little harm would come. The great majority of my midwifery has been done in cottages and under very cramped conditions and often insanitary surroundings. I fail to see what use overalls and rubber gloves can be to a man in my position, where one cannot often procure more than a couple of basins in the house and little or nothing to prepare a bed

properly for a lying-in woman, and often no help beyond some old woman neighbour; and yet all these cases which ought, according to all the laws of obstetrics, to go wrong do not! My precautions are limited to carbolic acid, lysol and abundance of soap and water.

I expect I would be classed by my friends the consultants with those who are known as "dirty doctors"; but I have no intention to depart from my technique or, as perhaps they would say, the absence of it. I am not ashamed of my record, and claim no merit for anything I am saying, except that it is the truth.

One word more, and it is this: I would not care to be in the position of a young, newly-fledged practitioner full of up-to-date learning on obstetrical technique if he examined a patient in labour per rectum and not per vaginam. I can imagine his being ordered out of the house as not knowing his job! No, Sir, our investigators will have, in my opinion, to look elsewhere for their sources of infection than the dirty doctor and dirty nurse. I do not dispute that they may occasionally be at fault. In the light of practical experience, however, it would seem that they are not so frequently to blame as some authorities would have us believe, or how does it happen I have been so immune from puerperal infection in my practice? I believe cases of this disease will go on occurring now and again in hospital and out of it with every precaution, because I believe we will have the autogenetic origin always with us, and I do not see how we are going to prevent it.—I am, etc.,

May 15th.

"OLD FASHIONED."

REFRACTION WORK AMONG SCHOOL CHILDREN.

Sir,—I write to support Dr. A. E. Larking's advocacy of utilizing both subjective and objective methods of estimating refraction errors (BRITISH MEDICAL JOURNAL, May 21st, 1921, p. 759), and I agree with him that three average cases per hour is as many as can be done really thoroughly.

Mr. Bishop Harman's method (with hole in blackened disc and a marked diameter—BRITISH MEDICAL JOURNAL, May 7th) is interesting and should be useful occasionally, but I differ entirely from him if his contention is, as I gather, that subjective testing (I mean as an adjunct) is useless in children "from, say, 5 to 14 years." He says "it is no use asking a child whether this or that glass is better than another, or what difference this lens of a fraction of a dioptré makes to clearness of vision." Quite so, but that is not really the way in which test-types are used. It is useless to say, "Is this glass better than that?" but if you have three or four cards and take care that lines which are supposed to correspond are not composed entirely of easily-read letters on one card and of difficult ones to read on another, then it is possible and useful to find with which glass the child reads (*not* says he sees) best.

Both retinoscopy and subjective testing contain sources of possible error, and it is obviously wise to check one method by the other in all cases where this can be done. Of course this takes longer to carry out, but real accuracy requires it, and if one has spent a few hours in fitting children with wrong glasses it is not much consolation to feel that one did as many as possible in the time.

In no class of patients, particularly in the class likely to attend eye clinics, can reliance be placed on complete cycloplegia being obtained by the home use of atropine in any form, and retinoscopy unconfirmed by subjective testing, performed on a patient with incomplete cycloplegia, is a poor thing on which to stake professional reputation and the patient's future comfort—and learning and earning capacity.

Mr. Harman is such an expert that in his hands unchecked retinoscopy will, no doubt, usually lead to a correct prescription; but the possibility of error is present even in his case, and in others less adept will frequently result in bad mistakes.

Mr. Harman's advice to learn on young adults with well-developed faculties is excellent, but a complete series of such is not usually available for the beginner. I began by learning all I could of retinoscopy and subjective testing in a hospital eye department and then doing the work for my own private patients, telling each of them to come back if not perfectly comfortable; and I would advise that

school medical officers should first learn all they can in hospital, and that when they start work in the schools should begin by selecting the older children, do both retinoscopy and subjective testing, and be content at first if they do one in forty-five minutes. One correctly prescribed for is worth any number incorrectly prescribed for.

I should like to enter a plea for the doctor doing the frame-fitting. This in the hands of an optician is frequently even worse than his sight-testing, and it can be done accurately in one minute a case when you know how, and are properly equipped.

It is unnecessary and even injurious to order very large, and especially round, lenses "to prevent the child looking over them." If the glasses are correct he will not want to look over them (if required, atropine can be continued for a week until he becomes accustomed to them), and if you make him an object of ridicule with glasses which are more than ordinarily disfiguring, he will probably wear them in his pocket.—I am, etc.,

Atrincham, May 22nd.

ARTHUR T. BLEASE.

Sir,—The letter by Dr. Arthur E. Larking under the above heading in the JOURNAL of May 21st, p. 759, calls for some comments.

First, the statement that a certain education committee expects its school medical officer to do at least "six" refractions in an hour. If this does not come under the heading of "sweated labour" I should like to know what does! Secondly, I am afraid Dr. Larking has taken Mr. Bishop Harman far too literally. Thirdly, the statement that Mr. Bishop Harman has let the secret out of the bag is a piece of sarcastic criticism that must not go by unchallenged.

It would appear that Dr. Larking accuses an accomplished ophthalmic surgeon of slipshod methods in refraction work. I am sure that Mr. Bishop Harman never intended it to be taken for granted that he, or any other refractionist, always prescribes glasses from retinoscopic findings alone without confirmation by subjective tests. Mr. Bishop Harman, and any other competent refractionist, would always confirm his retinoscopy, where possible, by the subjective method, especially if there be astigmatism present of more than one dioptre. There is no need to waste time testing subjectively in hypermetropia. It is advisable to apply subjective methods also in cases of myopia. Now, so far as astigmatism is concerned, one has a little latitude in cases that take a cylinder of one dioptre or less, but in cases requiring a cylinder from one dioptre upwards then one must place the cylinder as near as possible in the proper meridian.

For the above reason no ophthalmic surgeon would ever dream of prescribing lenses from retinoscopy alone without subjective verification in cases where this is possible. If the patient is too young for subjective sight-testing, then one has no alternative but to correct any refractive error by retinoscopy alone. One meets with many such cases, but they should be examined by a thoroughly competent refractionist alone. It requires very great experience before one is competent to write a prescription for glasses with any degree of accuracy from retinoscopic examination alone. It can be done, but any capable refractionist would much rather verify his findings subjectively.

There is no "letting secrets out of the bag." It is just a matter of experience and ability. It is quite possible to test the eyesight of six children in an hour, but even an expert like Mr. Bishop Harman would not like to do this regularly for two hours at a time. I have often done it, and in addition have measured each child's face with a face-rule giving the exact measurements for spectacle frames, but I would not do it regularly for £1,000 per annum. If a person were to keep up an average of four cases an hour, and do each case properly, such a school medical officer would be a person any education authority ought to be proud of; and if they ask for six cases to be done per hour, then they are asking for faulty work.

If an education authority makes a stipulation for six cases an hour, then such authority should be reported to the British Medical Association, in order that it might take action to put down such sweating methods.—I am, etc.,

J. PARKINSON HIGHAM,

Ophthalmic Surgeon.

Middlesbrough, May 23rd.

THE PREPARATION OF SCIENTIFIC PAPERS.

Sir, The letter of Sir James Barr in your issue of May 14th is so full of literary lapses, not to say of vulgar errors, that at first it suggested a deliberate trap for editors and proof readers; but if this is not so, you, Sir, have surely scored rather cruelly by printing it uncorrected.

Literary style is an elusive thing and not easy of definition. A style may be as rugged as you please, like Carlyle's, and yet be clear and forcible, but there is a peculiar awkwardness about the sentences of Sir James Barr which an attempt to read them aloud makes evident.

To take a few of his sentences *seriatim*, let us begin with this: "This discovery necessitated me verifying the references," and, in the matter of style, note the whole sentence: "This discovery necessitated me verifying the references, and as I have ceased subscribing for *this* Council's periodical since its price was raised . . . *this* letter has been delayed."

A few lines lower we meet this dark sentence:

"The BRITISH MEDICAL JOURNAL seems to be no less unfortunate" (no less than what?) "in its contributors, but it is not quite plain how they display their disregard, as a negative is rather difficult to display unless it be that of a photograph." Honestly, the meaning of this cryptic utterance is beyond my powers of elucidation; it is certainly "not quite plain." I have tried it by referring "they" to the contributors, and again by taking "they" to refer to the BRITISH MEDICAL JOURNAL, but the result is equally bewildering.

Split infinitives, I suppose, we must put up with, and the child was only two years old, which is certainly some excuse. When she is older she will know better.

Referring to "unwashed hands," Sir James says: "There is no verb to unwashen, whence then the past participle?" This forcible argument had better have remained unwritten. There is no verb "to unwrite," whence then the past participle?

Take another sentence: "If photographs were excluded, there would be no danger *that* 'the inclusion of inessential details in the background leading to confusion.'" True, it only needs the substitution of "of" for "that" to make sense, but you, Sir, as above mentioned, have been cruel.

Again: "An editor should have a fair working knowledge of his own language, and be able to spell, as the latter qualification [that is, being able to spell] is not an uncommon defect in many otherwise well educated writers." Here again a writer with a real appreciation of grammatical nicety would have written "is a not uncommon defect," which is not quite the same thing as "is not an uncommon defect."

Finally, the first two words of Sir James Barr's rules illustrate delightfully the very grammatical error against which he solemnly warns us in the second rule. "Only write," that is to say do not paint, nor draw, nor sing, but only write, "when you understand what you are going to write about." What Sir James presumably wished to inculcate was "Write only when you understand, etc.": but this is not what his rule, as written, ordains.

It is the old story of Dean Alford, recurring after an interval of sixty years.—I am, etc.,

Bronsgrove, May 17th.

H. CAMERON KIDD.

We have received a number of other letters criticizing Sir James Barr's literary style, but the points seem, in the main at least, to be covered by the above letter and that published last week. It appears, therefore, unnecessary to insert any more.

ELEMENTARY PSYCHOLOGY IN GENERAL HOSPITAL TEACHING.

Sir,—I have read with much interest Dr. William Caldwell's address on the above subject published in your last issue, p. 736. I suggest that Dr. Caldwell could accomplish his object by using his influence to secure the establishment of an out-patient department for mental cases at the Royal Victoria Hospital, Belfast. There are departments for such patients at practically all the "teaching" hospitals in London, and my colleagues at these hospitals will, I am sure, agree with me that the amount of material is almost more than they are able to

cope with, and affords excellent instruction for the students. It is my experience that it is an infrequent event for the "mental" cases to be of so severe a character as to require to be sent to a mental hospital.—I am, etc.,

R. H. STEEN,

Out-patient Physician in Psychological Medicine,
King's College Hospital.

Dartford, May 23rd.

Universities and Colleges.

UNIVERSITY OF CAMBRIDGE.

At a congregation, held on May 20th, it was agreed, on the recommendation of the General Board of Studies, to appoint a University Lecturer in Physics as applied to Medical Radiology, in connexion with the Special Board for Medicine, for a period of five years, with a stipend of £100 a year.

The following medical degrees were conferred:

M.B., B.Ch.—C. C. Okell.
B.Ch.—Man Wong; R. Hilton.

UNIVERSITY OF SHEFFIELD.

At a meeting of the Council of Sheffield University, on May 13th, Dr. F. E. Wynne (M.O.H. Sheffield) was appointed Professor of Public Health in succession to Dr. Harold Scurfield. The appointment is in accordance with the policy of the University of associating the public health work of the city with instruction given at the University. Mrs. May Mellanby, M.Sc., was appointed demonstrator of dental histology in the department of physiology, and Drs. Ferguson, Wilson, Eric Stacey, E. Barnes, and R. St.L. Brockman demonstrators in the department of anatomy.

The Council adopted a resolution expressing its regret at the death of Emeritus Professor R. J. Pye-Smith and placed on record its appreciation of his long and distinguished services to the University as a member of the council and as professor of surgery.

The Council's thanks were accorded to the Sheffield Panel Committee for its gift of war bonds and war stock of the nominal value of £1,000 for the purpose of equipping a research field laboratory in connexion with the medical faculty of the University.

UNIVERSITY OF EDINBURGH.

A MEETING of the University Court was held on May 16th.

Mr. Francis Gordon Bell, M.D., Ch.B., F.R.C.S.Eng., was appointed assistant examiner in systematic surgery in succession to Mr. R. C. Alexander, resigned.

Among the resignations intimated was that of Dr. John Beard as lecturer in comparative embryology and vertebrate morphology.

Mr. L. V. R. Becker was reappointed for a further period of six months from April as clinical tutor to the surgical out-patient department of the Edinburgh Royal Infirmary.

Recognition was granted to Dr. John D. Comrie as an extramural lecturer in the practice of physics.

ROYAL COLLEGE OF SURGEONS OF ENGLAND.

Primary Fellowship Examination.

THE following candidates have been approved at the first professional examination for the diploma of Fellow:

L. H. Appleby, D. C. G. Ballingall, F. G. Beatty, A. Blackstock, C. E. Bond, G. A. Brookes, H. A. Brookes, G. G. Bruce, J. T. Burrell, G. M. Cameron, G. H. Carlton, S. M. Cohen, J. R. M. Collie, R. S. Corbett, R. C. Davenport, C. O. Davies, S. N. Deboo, M. R. Flynn, G. N. Golden, L. B. Goldschmidt, W. D. Hart, G. T. Henderson, C. A. Horder, L. G. Housden, M. V. Hurley, S. F. Jacobson, J. Jamson, A. R. Jones, N. A. Jory, N. E. Lawrence, M. A. Lautre, K. W. Leon, A. R. Lister, C. A. Lynton, Gladys H. Marchant, J. Maxwell, Ruth E. Miller, W. Miller, L. Morris, T. D. Overend, J. A. Pantou, C. M. Pearce, N. A. M. Petersen, J. E. Purvey, B. T. Rose, J. P. Ross, Violet I. Russell, J. R. Smith, M. J. Smyth, W. O. Stevenson, Hilda N. Stoessiger, G. C. Swanson, D. B. Walker, A. D. Wall, E. C. Warner, F. W. Watkyn-Thomas, H. B. White, S. H. Woods.

ROYAL COLLEGE OF SURGEONS OF EDINBURGH.

Fellowship Examination.

At a meeting of the College, held on May 18th, the following seventeen successful candidates out of fifty-six entered, who passed the requisite examinations between January 10th and 15th, were admitted Fellows:

J. P. Blockley, J. W. Burns, A. C. Clark, W. A. Cochrane, T. Colley, C. C. H. Cuff, C. W. Graham, J. M. Hyde, V. J. F. Lack, T. Lindsay, Helen M. McMillan, W. Mercer, Mabel L. Ramsay, G. C. Scantlebury, S. Scouler, G. H. Stevenson, S. G. Whitfield.

The Bathage Memorial prize, consisting of bronze medal and set of books, has, after a competitive examination in materia medica, been awarded to Mr. J. M. McLintock, and the Ivson Macadam Memorial prize in chemistry, consisting of bronze medal and set of books, to Mr. J. Harkness.

CONJOINT BOARD IN SCOTLAND.

THE following candidates, having passed the requisite examinations, have been admitted Diplomates in Public Health:

R. B. Watson, R. B. Stewart, C. C. Brown, J. S. Elliot, J. B. Primmer, D. A. Cadman, A. I. Meek, J. Singh, J. C. Simpson, N. S. R. Lorraine, C. Milne, G. G. S. Jobston, D. T. M. Large, G. P. Taylor, Jane E. Hay.

Obituary.

GEORGE BLUNDELL LONGSTAFF, M.A., M.D., F.R.C.P. The death took place on May 7th, at his residence, Highlands, Putney Heath, of Dr. George Blundell Longstaff, in his 72nd year. Dr. Longstaff was the son of Dr. G. D. Longstaff of Wandsworth, and he was educated at Rugby, at New College, Oxford, where he graduated M.A. and M.B. in 1876, and at St. Thomas's Hospital, where he was a Mead medallist. He further obtained the diplomas of M.R.C.P., M.R.C.S., and the D.P.H. in 1877. He became a Fellow of the Royal College of Physicians in 1888, and took the degree of M.D. in 1891. Dr. Longstaff, so far as we are aware, never engaged in the practice of medicine, but he found his medical knowledge of value, at the time, for instance, of the Jamaica earthquake, for, happening then to be in Jamaica, he did a great deal of medical work among the people of the island. Dr. Longstaff devoted his life to philanthropic, municipal, and scientific work. He was for many years a member of the London County Council, and acted as chairman of the Building Act Committee. He served on many committees of the Charity Organization Society, had been a Poor Law guardian, was a Justice of the Peace, and a member of the Wandsworth District Board of Works. His father had been the first chairman of the Wandsworth Library Commissioners, and he himself joined the Board and succeeded his father as chairman. An ardent entomologist, he was a great collector, and the Hope Collection in the Oxford University Museum has been more than doubled by contributions he presented to it. He was the author of *Butterfly Hunting in Many Lands*, which was published in 1912.

A member of many learned societies, he had been vice-president of the Royal Statistical Society and of the Entomological Society, and was an authority on the analysis of animal and vegetable oils. Dr. Longstaff had served as one of the old Volunteers, and when the special constables were enrolled in 1914, at the outbreak of war, was one of the first to join; he became the first Chief Inspector of the Wandsworth Section, and attended keenly to his duties until ill health compelled him to resign in 1917. He was twice married, his second wife being a Fellow of the Geological Society, who was awarded the Murchison Geological Fund in 1898, and who has made many contributions to the publications of the Geological, Linnæan, and other learned societies. Dr. Longstaff's philanthropic, educational, political, and scientific activities made him one of the best-known and most highly esteemed public men in South London, where his loss will be greatly felt.

WE regret to announce the death, at Stewarton, Ayrshire, on May 8th, of Dr. THOMAS WATT, who was one of the best known medical practitioners in Paisley, where he had practised for over thirty-five years. Dr. Watt was educated at Glasgow University, where he first graduated M.A., and later qualified in medicine by graduating M.B., C.M., in 1886. He was senior visiting physician to the Royal Alexandra Infirmary, Paisley, and medical officer to the Post Office. He took a particular interest in the campaign against tuberculosis and in the establishment of sanatoriums for the borough and county. He had paid much attention to the question of a wholesome milk supply, and had travelled in Germany, Denmark, and Holland with a view to extending his knowledge on this subject. Dr. Watt, who had been in poor health for some time, was 59 years of age; he is survived by his widow, a daughter, and two sons, one of whom is carrying on his father's practice at Paisley.

LIEUT.-COLONEL THOMAS RANKIN MACDONALD, Bengal Medical Service (retired), died at Inverness on May 8th. He was born on May 17th, 1853, educated at Edinburgh, where he graduated M.B. and C.M. in 1876, having pre-

vously taken the L.R.C.S. Edin. in 1875, and at Vienna, and entered the I.M.S. as surgeon on March 31st, 1880, becoming lieutenant-colonel after twenty years' service, and retiring on June 20th, 1900. While on furlough prior to retirement he took the F.R.C.S. Edin. in 1899, and after retiring was for a time in partnership with his uncle, the late Dr. MacLeod of Hawick, after which he settled in Inverness. He served in the Egyptian war of 1882, was at the battle of Tel-el-Kebir, and received the medal with a clasp and the Khedive's bronze star. He was also one of the I.M.S. officers deputed to Egypt for special cholera duty in 1883. The rest of his service was mostly passed in civil employ in Burma and Bengal.

Medical News.

H.R.H. THE DUKE OF YORK will open King George's Sanatorium for Sailors, a branch of the Seamen's Hospital Society, Greenwich, at Bramshot, Hants, on July 12th.

MADAME CURIE has been presented by the President with a gram of radium subscribed for by women of the United States. She has received the honorary degree of LL.D. from the University of Pennsylvania and that of M.D. from the Women's Medical College, Philadelphia.

DR. RUSSELL J. REYNOLDS has been appointed radiologist to Charing Cross Hospital, in succession to the late Dr. W. Inroside Bruce.

THE annual dinner of the Harveian Society will be held on Wednesday, June 22nd, at 7.30 p.m., at the Café Royal, Regent Street, W.

THE medical conference arranged by the Industrial Welfare Society will be opened at 51, Palace Street, London, S.W., on June 2nd, at 10.30 a.m., when Dr. R. M. Wilson will introduce the subject of "Medical service in industry." In the afternoon the subject of "Health problems in industry" will be discussed by Professor E. L. Collis, Dr. T. M. Legge, and Dr. Halford Ross.

A MEETING convened by Dr. Marie Stopes will be held at Queen's Hall on May 31st, at 8.30 p.m., to discuss "Constructive birth control." The speakers will include Dr. Jane Lorimer Hawthorne and Dr. C. Killick Millard.

DR. W. J. HOWARTH, C.B.E., medical officer of health for the City of London, has been elected President of the Society of Medical Officers of Health for the session 1921-22; he will take office in October next. The honorary fellowship of the society has been conferred on Dr. Alfred Hill, formerly medical officer of health for the city of Birmingham, "for long and distinguished services to preventive medicine and public health administration." Dr. Hill, who has just entered his 96th year, was president of the society in 1886 and 1887. The annual provincial meeting of the Society will be held on Saturday, June 11th. Members will assemble at the house of the Society at 10.30 a.m., and proceed by motor coach to Hatfield House, which will be visited by invitation of Lord Salisbury. Afterwards the party will be entertained at luncheon at Welwyn Garden City by the president of the Society, Dr. F. E. Fremantle, M.P. The Welwyn housing and town-planning schemes will be inspected, and Mrs. Fremantle has invited members to tea at Bedwell Park. Members who intend to be present are asked to give early notice to the Executive Secretary, 1, Upper Montague Street, Russell Square, W.C.1, stating if they will be accompanied by ladies; 10s. 6d. should be forwarded for each motor coach ticket.

At the Marylebone Police Court, on May 9th, Hugh Morton, of Park Lane (formerly of 15, Cavendish Place), appeared to answer three summonses under the Venereal Diseases Act, and one summons under the Medical Act, issued against him at the instance of the Medical Defence Union, Limited. The facts upon which the prosecution relied were admitted by the defendant, and the magistrate, after hearing counsel and without calling witnesses, imposed a penalty of £30 in respect of each offence under the Venereal Diseases Act, and £20 in respect of the offence under the Medical Act, with five guineas cost on each summons; and sentenced the defendant to two months' imprisonment in default of payment of the fines and costs within seven days.

THE Inland Revenue authorities received in the financial year ending March 31st, 1920, the sum of £1,332,661 in payment of patent medicine labels in Great Britain alone, an increase of £266,967 over the amount received under the same head in the previous financial year. The duty on

the labels varied from 3d. to £2, according to the price of the medicine. The number of licences issued to makers or vendors of patent medicines in Great Britain during the financial year 1919-20 was 41,671, yielding a net revenue of £10,421; the corresponding figures in the previous year were 39,675 and £9,920.

THE summer meeting of the Section of Laryngology of the Royal Society of Medicine will be held on June 2nd, 3rd, and 4th. On the afternoon of Thursday, June 2nd, and on the morning of Friday, June 3rd, a number of papers will be read and cases shown; while on the afternoon of June 3rd a number of special demonstrations will be given, followed by the ordinary meeting of the Section. A dinner will take place in the evening at the Trocadero Restaurant. On the morning of Saturday, June 4th, the laryngological staffs of University College Hospital, the Central London Ear and Throat Hospital, and other hospitals will perform special operations.

THE British Congress of Gynaecology and Obstetrics will hold a meeting at the Queen's Hotel, Birmingham, on Friday and Saturday next, June 3rd and 4th.

THE Belgian Minister of Sciences and Arts, in response to the request of the Faculty of Medicine, has resolved to create a chair of psychiatry at the University of Ghent.

DR. KENNETH E. ECKENSTEIN, pathologist to the French Hospital, London, who served during the war as a medical officer in the French army, has received the honour of Chevalier of the Legion of Honour.

DR. CHARLES ABADIE of Paris was entertained at a banquet on May 12th in celebration of his medical jubilee.

THREE post-graduate courses, conducted by the pediatric, obstetrical and gynaecological, and oto-rhinolaryngological clinics respectively, will be held in the University of Naples, commencing on May 30th and continuing for two to three months. The courses will be of a practical character, and the numbers will be limited.

DR. HUBLET WORK, president of the American Medical Association, has been appointed by President Harding First Assistant Postmaster-General.

DR. CANYT, a former clinical assistant of Professor Moure, has been appointed to take charge of the department of oto-rhino-laryngology in the faculty of medicine at Strasbourg.

AN exhibition of radiographs will be held by the Röntgen Society in the Royal Photographic Society's rooms, 35, Russell Square, W.C., during the month of June. The exhibition will be open daily (Sundays excepted) from 10 a.m. to 5 p.m., and all who are interested are invited to attend.

A POST-GRADUATE course in medicine, particularly on the application of laboratory methods to diagnosis, will be held during July next at the Hôtel-Dieu, Paris, under the direction of Professor Maurice Villaret, with the co-operation of a large staff. The course will begin on Monday, July 4th, and will include thirty-two lectures and demonstrations, taking place thrice daily. The fee is 150 francs, and a certificate will be given at the end of the course. Particulars may be had from the secretary of the Faculty of Medicine, University of Paris. In connexion with this course a tour of study has been arranged, from July 9th to 17th, to the spas of the Pyrenees, the detailed programme of which can be obtained from Dr. Dausset, at the medical clinic of the Hôtel-Dieu.

THE report of the Home Service Ambulance Committee for the first quarter of the year shows that the institution of an ambulance service in the country has been justified by the work that the vehicles have accomplished. It is now two years since the inauguration of the scheme as part of the peace work of the Order of St. John and British Red Cross Society, and the successive reports prove that as the existence of the ambulances has become known, steady progress has been made in their use for the transport of the sick. The number of cases carried during the March quarter was 11,392, being 3,623 in excess of the total for the previous quarter. The Committee is recalling the old ambulances used during the war as they become unfit for service and replacing them by new ambulances of a lighter type; this change, it is hoped, will have several advantages, including a reduction in the cost of maintenance.

ACCORDING to the New York *Medical Record*, the prohibition director for Illinois has announced that each of the 2,000 druggists of Chicago may withdraw 200 gallons of whisky and 200 gallons of wine every three months. The commissioner of internal revenue has announced that this quantity could be increased if the druggists could show that they really needed more liquor to supply the demand. At this rate Chicago will use 3,200,000 gallons of wine and whisky a year for her 3,000,000 inhabitants.

Letters, Notes, and Answers.

As, owing to printing difficulties, the JOURNAL must be sent to press earlier than hitherto, it is essential that communications intended for the current issue should be received by the first post on Tuesday, and lengthy documents on Monday.

CORRESPONDENTS who wish notice to be taken of their communications should authenticate them with their names—of course not necessarily for publication.

AUTHORS desiring reprints of their articles published in the BRITISH MEDICAL JOURNAL are requested to communicate with the Office, 429, Strand, W.C.2, on receipt of proof.

In order to avoid delay, it is particularly requested that ALL letters on the editorial business of the JOURNAL be addressed to the Editor at the Office of the JOURNAL.

THE postal address of the BRITISH MEDICAL ASSOCIATION and BRITISH MEDICAL JOURNAL is 429, Strand, London, W.C.2. The telegraphic addresses are:

1. EDITOR of the BRITISH MEDICAL JOURNAL, *Aitology, Westrand, London*; telephone, 2630, Gerrard.
2. FINANCIAL SECRETARY AND BUSINESS MANAGER (Advertisements, etc.), *Articulate, Westrand, London*; telephone, 2630, Gerrard.
3. MEDICAL SECRETARY, *Medisecra, Westrand, London*; telephone, 2630, Gerrard. The address of the Irish Office of the British Medical Association is 16, South Frederick Street, Dublin (telegrams: *Bacillus, Dublin*; telephone, 4737, Dublin), and of the Scottish Office, 6, Rutland Square, Edinburgh (telegrams: *Associate, Edinburgh*; telephone, 4361, Central).

QUERIES AND ANSWERS.

SELF-NOTIFICATION.

"Q," who was suffering from malaria and trench fever, notified the M.O.I.L. on the official form; he has not received payment. He asks whether a medical practitioner is ever justified in notifying himself as a case of infectious disease, and if so, whether he is entitled to a fee.

*. The Infectious Disease (Notification) Act, 1889, and subsequent General Orders require a medical practitioner upon becoming aware that a person upon whom he is in medical attendance is suffering from certain specified diseases, to send to the medical officer of health of the district a notification of the case. The local authority must pay a fee to the medical practitioner for this service without further demand on his part. Failure on the part of the practitioner to send the notification renders him liable to a fine. It is conceivable that the practitioner might himself be the patient and that he might be in "medical attendance" on himself, in which case he must send a notification to the medical officer of health and is entitled to the fee.

SUMMER PRURIGO.

DR. H. B. BINKS (Merthyr Tydfil) asks for advice in the treatment of a boy of 12, pale and freckled, who has suffered every summer for the last five years from a vesicular eruption on the exposed parts of the face and neck. The vesicles are at first the size of a pinhead; they gradually become more opaque and turbid, and then show dark in the centre. Unless reinfected they dry off without leaving a visible scar.

*. A dermatologist to whom the question has been referred writes: The history of this patient suggests that he suffers from a form of summer prurigo, a disease first described by the late Sir Jonathan Hutchinson. The fact that he is freckled is a point slightly against this diagnosis. Freckles are the natural reaction of the skin to the stimulus of strong light, and their presence should protect it against inflammatory lesions such as those described. Treatment is not easy; care should be taken to shield the face and neck by wearing a wide-brimmed hat, and the use of a red veil has been recommended; this might be a practical measure for a girl but hardly for a boy. The discomfort arising from the eruption can be allayed by the use of the ordinary cooling lotions containing calamine, zinc oxide, and glycerin. There is a tendency for the eruption to lessen with the advent of adolescence.

INCOME TAX.

"T. A. S." bought, in March, 1921, in conjunction with a partner, a practice in which he had been acting as assistant.

*. The two partners are assessable as for 1921-22 on the basis of the three years' profits of the practice to December 31st, 1920, or March 31st, 1921, if more convenient. Those profits were the earnings of the practice after the salary to "T. A. S." had been deducted, and the Acts contain no provision which would authorize the Revenue authorities to compute the profits in any other way. For the purpose of calculating the tax due, the gross assessment so arrived at should be shared between the present partners on the same basis on which their actual profits are shared.

"A. A.," who is tuberculosis officer to a county council, receives an allowance for expenses computed on the basis of the cheapest means of conveyance, tram, bus, etc.; in fact, he uses a motor car and so saves several hours a week. He asks if he is entitled to deduct from his salary his out-of-pocket expense on the car.

*. The emoluments in question fall under Schedule E and expenses can be deducted only if "incurred wholly, exclusively, and necessarily in the performance of the duties." We think that our correspondent could not establish to the satisfaction of the Commissioners hearing the appeal that the additional expense of locomotion incurred by him was necessary in the performance of the duties, in which case his claim would fail for lack of proof.

LETTERS, NOTES, ETC.

"E. G. C."—Tanned human skin becomes so dark that without a microscopic examination it would not be safe to decide if it was that of a white or a coloured person. If our correspondent could furnish a small piece, we will endeavour to have the question determined.

DIFFERENTIAL STAINING OF CARCINOMATA.

DR. A. G. SHERA, in a further letter which may well end this correspondence, writes that he did not accuse Dr. Kuyvet Gordon of inexperience, but only that "the mature opinion of an expert histologist would be more satisfying." The expert histologists in this country, in the opinion of one well able to judge, may, Dr. Shera says, be counted on the fingers of two hands. The method referred to is being tried out in expert hands, so that Dr. Shera feels that the last word in criticism is not yet uttered.

SIGNS AND SYMPTOMS.

"CLINICIAN" writes, with reference to a recent correspondence on this subject: Evolution is essentially a physiological (defensive) process. It is physiological at first, secondly anatomical, and finally a fusion of both. It is a property or process of the biological (that is, living) world, in which man is the Z of its alphabet. When man is attacked by disease we have "warfare in the human body," and when this war is heard by the patient and told to his doctor, it is a *symptom* of its presence; and when it is felt by the patient or his doctor, it is a *physical sign* of its presence.

TWINS.

DR. C. A. ENSOR (Aberley Park, S.E.) writes: A few days ago, whilst inquiring into the family history of a patient, I elicited the following facts: (1) Her mother had had twins thrice; (2) three of the patient's sisters have had twins twice; (3) she herself has had twins three times, but at birth was a "singleton."

PARABOLIC REFLECTOR LAMP.

THE safety parabolic reflector oil lamp made by Mr. J. Bruce (232, Borough High Street, London, S.E.) has been used in Guy's Hospital for the past twenty years, and is well known to a good many members of the medical profession. Inspection of the sample we have lately received suggests that the quality of the workmanship and material is well maintained. By the use of the plated parabolic reflector a bright light can be concentrated on any part of a room. The lamp should be especially useful in country consulting rooms and surgeries where electric light is not available; it can be used either as a hand lamp or hung on a wall. The price of the nickel-plated form is 10s. 6d., post free to addresses in the United Kingdom.

VACANCIES.

NOTIFICATIONS of offices vacant in universities, medical colleges, and of vacant resident and other appointments at hospitals, will be found at pages 31, 32, 33, 34, 35, 38, and 39 of our advertisement columns, and advertisements as to partnerships, assistantships, and locum tenencies at pages 36, 37, and 38.

THE appointment of certifying factory surgeon at Peterculter (Aberdeen) is vacant.

SCALE OF CHARGES FOR ADVERTISEMENTS IN THE BRITISH MEDICAL JOURNAL.

	£	s.	d.
Six lines and under	0 9 0
Each additional line...	0 1 6
Whole single column (three columns to page) 7 10 0	7	10	0
Half single column	3 15 0
Half page	10 0 0
Whole page	20 0 0

An average line contains six words.

All remittances by Post Office Orders must be made payable to the British Medical Association at the General Post Office, London. No responsibility will be accepted for any such remittance not so safeguarded.

Advertisements should be delivered, addressed to the Manager, 429, Strand, London, not later than the first post on Tuesday morning preceding publication, and, if not paid for at the time, should be accompanied by a reference.

NOTE.—It is against the rules of the Post Office to receive *postea restante* letters addressed either in initials or numbers.

A Defence of the Thesis

THAT

“THE OPPORTUNITIES OF THE GENERAL PRACTITIONER ARE ESSENTIAL FOR THE INVESTIGATION OF DISEASE AND THE PROGRESS OF MEDICINE.”*

BY

SIR JAMES MACKENZIE, M.D., F.R.C.P.,
LL.D., F.R.S.

CONSULTING PHYSICIAN TO THE KING IN SCOTLAND, DIRECTOR OF THE ST. ANDREWS INSTITUTE OF CLINICAL RESEARCH, CONSULTING PHYSICIAN TO THE LONDON HOSPITAL.

Introduction.

My object is to demonstrate that the conception of medical research which is dominant to-day is so immature and imperfect that it renders fruitless much of the research work. Indeed, so imperfect is the conception that fields essential to medical progress are not recognized. It is well, therefore, that men engaged in medical research should at intervals pause and consider what they are doing, so that they clearly realize the object of their endeavour and be certain that their methods are suited to their purpose. Never in the history of medicine has there been such activity as now, and there never was a time when it was more necessary to have a clear perception of aims and methods, especially as great schemes are being launched in legislation, in research, and in education. If these schemes be based upon immature experience and imperfect knowledge, the progress of medicine may be hampered for generations.

We are all the creatures of circumstance, and our ideas are moulded by our experiences. Those employed in the study of medicine look at the subject in the light of their own experiences. As the subject is so large, one individual can have an experience of but a small part, so that there is no one capable of seeing it as a whole. The result is that medicine has to be studied in sections, and this leads to specialism. The authorities who guide and direct the progress of medicine are therefore men with but a limited experience, and this leads to a limited outlook. In an attempt to bring together a body of men whose united experience, it might be thought, would cover the whole field, there is a danger that some section may be wanting, and thus a distorted view or a view lacking in perspective may be obtained.

A review of medical progress reveals the fact that medicine is emerging, slowly and hesitatingly, from a past burdened by tradition and even superstition. The conception of what constitutes medical science is still so imperfect that no clear understanding exists on what lines it should be pursued. While the aim of medicine may be recognized, the methods by which this aim may be achieved are not yet understood, and this lack of understanding is leading medicine astray.

In dealing with the clinical aspects of research, and particularly with the opportunities of the general practitioner, I must dwell upon the limitations of laboratory methods, and I may seem to belittle their importance. This is far from my intention. No one recognizes the importance of laboratory methods more than I do, and probably no clinical observer has received greater help from them. Indeed, I consider that I have a better appreciation of their methods than many who indiscriminately belaud them. My experience not only enables me to appreciate their value, but also to recognize their limitations.

Successful Methods in Research.

Let us briefly look at one aspect of the subject by considering where medical research has been successful. The highest aim of all research is the prevention of disease. If we take the instances where this aim has been achieved we find a uniform method of procedure. In every case the clinical observer, by the exercise of his peculiar methods, took the first step. He recognized in the sick man the signs of disease, he differentiated these signs in such a manner that he was able to recognize

separate forms of disease. He recognized these signs at such an early period that he detected the circumstances that favoured or induced the disease. He was then able to take steps to prevent the disease. Such is the history of the prevention of such diseases as typhoid fever, syphilis, rabies. At other times he has not been able to carry the investigation so far, and recognizing his limitations he handed the subject over to the laboratory worker, as in malaria and allied diseases.

Such in brief is the method which common sense tells us should be followed in the case of every disease, but where is the clinical observer to be found to-day?

A foolish idea has arisen that the methods by which he made his contributions to research are so easily understood that they need little consideration, and so easily recognized that they need no special investigation, and that their possibilities are exhausted. There never was a greater fallacy. We know that it takes many years before a man becomes trained in bacteriological technique. It requires a much longer time to train a man to recognize the early symptoms of disease. It takes many years of experience to put intelligent questions to the patient, and more years of experience to enable the replies to be interpreted.

The part which the clinical observer should play in medical research is to-day not recognized, and there follows as a consequence an insurmountable obstacle to attaining the chief aim in medicine—the prevention of disease. If you do not recognize the early symptoms of disease you can never recognize the circumstances that favour or cause its onset. This to me is such plain common sense, that it is one continual source of wonder that our authorities fail to see it.

Once this is seen, the next question is, Who is the man that has the opportunity for seeing the early stages of disease, and the circumstances that favour its onset? There is only one person, and that is the general practitioner.

The Diseases Common among the People.

When we started our enterprise at St. Andrews, we reflected that if success were to attend our efforts we must clearly perceive what we were aiming at. Our chief aim was the prevention of diseases which are common among the people of the country.

The question arose “What are those diseases?” Seeing that we have now a Ministry of Health one would naturally expect that this knowledge would be in its possession. Seeing also that doctors are being educated to combat these diseases, it might have been expected that educational authorities would know. But a brief inquiry revealed the fact that this knowledge does not exist.

The reason for the absence of a knowledge so essential to intelligent law-making, education, and research, is that it can only be obtained by the general practitioner, and no one ever thinks of asking him to undertake any inquiry.

We therefore started an inquiry into this matter, and met unexpected difficulties. However, we got an insight into the matter that revealed defects in medical knowledge so great that they more than justified our undertaking.

One fact that came out clearly was that the impression that great progress had been made in recent years was scarcely justified, so far as the recognition and prevention of disease was concerned. We found that discoveries of the origins of common diseases were so few during the past fifty years that we had difficulty in recognizing any advance. A little consideration revealed the reason.

The Progress of Medicine during the Past Century.

A hundred years ago we can trace medicine following two distinct paths: There was the clinical school, mainly British, in which the chief instrument was the clinical observer with his trained senses and his mind stored with the fruits of his past experience. There was the growing laboratory school, mainly Continental in its origin, which received a great impetus when Virchow introduced the theory of cellular pathology. Up to fifty years ago the trained observer was slowly unravelling the early symptoms of disease, discovering the beginnings of disease and their cause. With the increase of knowledge of the structure of the body and of the modifications produced by disease, and by improved laboratory technique, pathology gradually came into prominence. The dead-house became the centre of great activity. The accurate observation of diseased organs revealed on the *post-mortem* table led the

* Being a lecture delivered at St. Mary's Hospital, in the Institute of Pathology and Research during the course on Pathological Research in its Relation to Medicine.

physician to seek in the living the evidences of these diseased organs, and thus was laid the foundations of that physical diagnosis which we know to-day. The seeming sufficiency of this method of study led to a classification of disease based upon the morbid appearances of the organs, a classification which survives and influences teaching to-day.

There is a delusive precision in this classification which has had a pernicious effect on medicine as a whole. It may be true of disease as seen from the dead-house point of view; it may be partly true of disease as seen from the point of view of the medical and surgical wards, but it is so little true as to be misleading when looked at from the point of view of the general practitioner. It is misleading because it deals only with end-results, a totally different matter from the early stages of disease. These end-results may be the diseases imposed upon a constitution already enfeebled, or the outcome of a process whose symptoms in the early stages have never been recognized. One outcome of this classification has been to rivet the search on those signs which occur only in advanced states of disease—when, that is to say, damaged tissues produce a physical sign. So powerful has this influence been that attention is now concentrated on the search for improved methods by which these physical signs can be revealed. So many methods have been discovered that men have to devote themselves to special branches, and we see the result in the specialism of to-day. It seems not to have been grasped that the specialist can only recognize disease after it has gone so far as to damage the organs, and no specialist ever sees the early stages of the disease in which he specializes.

Following upon the introduction of more accurate pathological investigation came the microbic theory of disease, with its startling revelations and successes. The imagination of the medical world was fired, and the most exaggerated expectations were formed of what it could do, and thus it practically superseded all other methods of investigation, and speedily attained that dominant position which it holds to-day. Following in its track came the introduction of the methods of other sciences, and there arose that conception of medicine which looks to the laboratory as the only sphere of progress. As a result the methods of the clinical observer by which so much had been achieved fell to the background, and as an investigator he gradually disappeared. This was a calamity, and the more so that neither the part he should play or the opportunities which he possesses are understood.

Movements in Circles.

Between the town of Barnley and the village of Haworth, where Charlotte Brontë lived, there stretches a wide moor. Some of my friends started one day to walk from Burnley to Haworth. About an hour after they started a heavy mist fell and they lost their way. They happened on a shepherd's cottage and the shepherd gave them their directions. In three hours they were back again at the cottage, having wandered in a circle. This well-known tendency to walk in a circle is a human peculiarity that affects not only bodily movements but mental. History shows civilizations that arise, make a little progress, then make no further progress, but move round and round and gradually relapse. Religions, too, can show the same process. This kind of arrested development affects individuals, for we all know how many young men start out in life with every prospect of going far, and after middle age are found muttering the shibboleths of their youth.

There are signs that this tendency hampers medical progress, and much of what we assume to be progress is but moving in a circle, and results which are taken as signs of progress often but add to the fog which obscures the way.

PROGNOSIS.

I do not develop this theme to-day, but my purpose is to direct your attention to a subject which illustrates this point of view. I choose one with which you all are familiar—indeed many may think it so well known that it needs no consideration. It is, moreover, a subject which acts as a guide to progress, a beacon in the fog, and at the same time provides the means by which progress or the reverse can be judged. Moreover, it is a subject of the very first importance to the intelligent practice of medicine;

but I do not know how to present it in a manner that will convey to you its significance so as to carry conviction.

When a true insight is obtained into what medical science means it will be found that the great obstacle to progress is a lack of understanding of prognosis. Up to thirty or forty years ago the subject was making progress slowly and crudely but definitely. During the last quarter of a century it has got such a set-back that to-day its importance is not understood, the principle which should guide to its knowledge is not appreciated, and the individual whose opportunities afford the means of acquiring this knowledge is not recognized.

I have repeatedly discussed this matter with various authorities in different departments of medicine, and nowhere can I get anyone to appreciate its real nature. The newly qualified doctor is as oblivious to its importance as the matured physician who has for twenty or thirty years been engaged in life insurance examinations, in which it is currently assumed that a prognosis is necessary.

If one wanted evidence of the complete misconception of this subject, it is the practice of appointing laboratory trained men to teach clinical medicine, and the assumption that as soon as a man is qualified he is capable to examine recruits for the army and navy and candidates for life insurance. If I can get you to understand the meaning of prognosis, the futility of these procedures will be apparent to you.

The Importance of Prognosis.

In medical practice one question arises incessantly and persistently, implied or expressly demanded of the doctor, and that question is, "What is to be the outcome of my complaint?" The patient or his friends want to know if the illness is temporary or is it to result in ill health or in death. Then other questions arise, Are there remedies for this complaint, and what are they?

To answer these questions requires a knowledge of prognosis, and one of the cherished beliefs of the public is that doctors possess that knowledge. Moreover, common sense tells us that the public is perfectly justified in expecting from the doctor a knowledge so manifestly essential to the intelligent practice of medicine.

The Peasant and Prognosis.

I was presenting these views once to a very capable general practitioner who had had a distinguished university career. He cordially agreed, and described an incident which forced on him the importance of prognosis, when he entered upon practice. A few days after starting as an assistant to a general practitioner he was called to see a sick ploughman. He examined him and diagnosed a pleurisy. Pleased with his diagnosis, he, in learned fashion, informed the man's wife. She replied, "Aye, but when is my man to be fit for his work?" My friend was taken aback—during the whole of his education he had never been taught to realize that such a question should be asked, and he could not himself answer what he recognized to be a most natural question. I have little hesitation in saying that this poor peasant woman had instinctively a better realization of the requirements of medical practice than the authorities to-day who direct medical education and research.

Let me give some instances illustrating this peculiar defect in medical knowledge.

Recruiting and Prognosis.

Of the vast importance of prognosis and of the disastrous effects of a lack of knowledge of this subject we have had during the war striking evidence. When at a time of great national stress a call was made for men to join the army, it was assumed by the nation, as well as by the military medical authorities, that there existed sufficient knowledge to separate the fit from the unfit. This was really a test on the greatest scale of the adequacy of medical knowledge. At the outset the knowledge was found wanting, for large numbers of perfectly healthy men were rejected, because they presented signs whose value the medical examiners were unable to assess. Later, when the national strain became greater, and it was necessary that even those with impaired health should enter military service, the military authorities again thought they possessed the knowledge necessary to say what amount of physical effort a man was fitted for. It is unnecessary to dwell upon the complete

failure that resulted. So glaring were the mistakes, so unjust were the decisions, that the whole nation was aroused and Parliament was forced to intervene. If there was ever a need for inquiry, here was one; yet the whole matter is brushed aside as if it had never occurred, and medicine has fallen back into its old ways. This illustration shows how backward is the state of medicine when the authorities who direct it are incapable of realizing a defect even when their best endeavours end in a miserable failure.

Prognosis in Surgical Practice.

Another aspect of the subject is shown in surgical practice. If we take a common complaint like appendicitis, there are certain signs which are held to indicate the presence of this disease. The question arises whether these signs indicate a condition which will endanger the patient's life. In other words, what is the prognostic significance of the signs? The question is one of prime importance to the patient, for it may be a matter of saving his life if the danger is recognized and removed; on the other hand, it may be putting the patient in danger by an unnecessary operation—danger to life or of permanent damage to his health.

Many a patient has had his appendix removed when there was nothing the matter with it. Everyone recognizes that appendicitis does occur, and, if not operated on, death may result. The attitude of the surgeon to-day is that, seeing that there is danger, and seeing that surgical knowledge cannot discriminate between the cases where there is danger and those where there is no danger, it is safer to operate. It is the same in the surgical treatment of gastric ulcer. I have seen patients greatly benefited by the operation; I have seen some made worse by the operation, and I have seen patients die in consequence of the operation. These results are due to an absence of a knowledge of prognosis.

Prognosis and Vaccine Therapy.

The development of the bacteriological branch of medicine has resulted in the introduction of new forms of treatment by serums and vaccines. When a person is ill, and a microbe is the suspected cause, the appropriate treatment is to combat this microbe by a vaccine. But here arises the question, Is the patient likely to recover without treatment? If so, then the treatment is unnecessary. If the patient is in danger of death, wherein lies the danger—is it due to that microbe or to other complications?

This is not quibbling, but is essential to intelligent treatment. For instance, I have heard it seriously proposed to find the microbe of measles, and then to get a vaccine to give to patients afflicted with measles, because many people are supposed to die of measles. But the question arises, Do they die of measles? During my twenty-eight years in practice I saw numerous epidemics of measles, and only two patients died; but these did not die of measles but of complications—laryngitis and bronchopneumonia—brought on through injudicious exposure. If due care be taken, why give the vaccine? Unless the source of danger is recognized and provided against, the treatment by vaccines becomes rule of thumb, and is but a reversion to the empiricism of bygone times.

If treatment is to be intelligent, or even scientific, a prognosis is absolutely essential, yet in some recent textbooks on surgery and vaccine therapy I do not find the word prognosis mentioned.

Prognosis in Treatment by Digitalis.

Did time permit I could illustrate in many ways how essential prognosis is to scientific treatment. Let me give one example. For more than one hundred years it has been recognized that digitalis had a beneficial action in certain forms of heart disease, but no definite knowledge existed as to the kind of heart disease which benefited, so that every person supposed to have a heart affection was given digitalis. Careful investigation has revealed that the drug is of use in only a small percentage of cases, and that of a particular kind. We can now recognize with fair certainty the cases where it will have a good effect and those cases in which it is of no use.

The recognition of the cases that are benefited by digitalis saves us from giving it to those cases in which

it is of no use. Thus, instead of an unintelligent rule of thumb treatment, we study the peculiarities of each individual case in order to find the treatment appropriate to his condition. The manner in which this knowledge was acquired will be described later.

The Investigation of Prognosis.

It will perhaps help to get a clear idea of what I am aiming at if I describe the steps I took to obtain this knowledge in affections of the heart.

On entering general practice my knowledge was much that of the young doctor of to-day, except that perhaps we were better taught in regard to this subject. I was not long in finding out that my knowledge was limited. As an examiner for life insurance I realized that I had no real knowledge of the prospects of a candidate's life. In dealing with my patients I would put people on treatment and restrict their work because of some *vaguo* notion that murmurs and irregular action indicated something seriously wrong. The textbooks, to which I appealed again and again, though reputed to deal with prognosis, afforded no help. Recognizing the limitation of my knowledge, I determined to see if it was possible for this knowledge to be acquired.

I saw at once that it would be necessary to watch individuals with what I considered damaged hearts for the rest of their lives to see what happened, and I started to do so. But the question soon arose, What was I to watch? I spent a long time noting with great particularity the murmurs and modified sounds, and the rate of the heart when at rest and on effort. But the results were so unilluminating that I found I was getting no farther. I got a sphygmograph and took records of the pulse, and spent much time measuring the height and breadth of the waves, the depth of the notches, seeking in these signs for light upon the subject of prognosis.

In efforts of this kind I spent several years, and felt inclined to give up in despair. My experience at this stage may be of some service to others who undertake similar forms of medical research. Pausing to reflect, I was struck with the resemblance of myself to one of the characters depicted by Bunyan in his *Pilgrim's Progress*. He describes a man earnestly engaged in raking the mud in search for something he was not quite clear about, while above his head shines the crown of glory which was the real object of his research. I felt like the man with the "muck-rake," and I felt certain if he were addressed in modern terms the conversation would be somewhat as follows. If asked what he was doing, he would reply he was collecting stones and twigs and straws. If it was suggested that this seemed a vain quest, he would reply that he was discovering new facts, and as a new fact was an addition to the sum of human knowledge, the quest was therefore justified. Moreover, he might add: I am the first to introduce scientific methods in this research, as I weigh the pebbles and measure the straws.

Rules for the Investigation of Symptoms.

I saw that I must have some clearer guide in my work. I reflected that I had to deal with people in ill health, and the nature of their ill health could only be discovered by understanding the symptoms of disease. The physicians of thirty or forty years ago were, many of them, very capable men. Their minds were not distracted by the numerous methods which to-day are considered necessary for the examination of their patients, so that they cultivated their powers of observation. I had been struck during my student days, and later when I entered practice, by the rapidity and precision of diagnosis, in patients who presented no physical sign, and the assurance with which they would foretell whether an illness would pursue a favourable or unfavourable course. The old doctor to whom I was assistant possessed this faculty in an eminent degree, and I often to-day reflect with admiration on the remarkable certainty of his diagnosis and prognosis. When I was considering my future to get forward with my investigation I reflected on these matters, and I saw that this knowledge was due to the recognition of subtle signs which could only be detected and appreciated from long and careful observation. The knowledge was personal, and medicine had not advanced so far as to enable a description to be given which would convey the knowledge to others.

Seeing that disease makes itself manifest only by the symptoms it produces, I recognized that the first step in my undertaking would be to acquire a better knowledge of symptoms. In order that my inquiry should be directed in a systematic manner, I laid down three rules for guidance.

1. To differentiate each symptom clearly, and separate it from others it might resemble.
2. To discover the mechanism by which each symptom was produced, and to search for the laws governing the production of symptoms.
3. To assess the value of the symptom, so far as it had a bearing on the patient's future—the prognostic significance of the symptom.

By following these rules I hoped to get an insight into the nature of the diseases of my patients, and to find out the explanation of the older physician's power of diagnosis and prognosis. This was all the more necessary since the vast majority of my patients had no gross physical sign of disease, the symptoms being mainly subjective, or of such a subtle and elusive kind as could only be detected by the trained senses.

Except incidentally, I do not propose to refer to the steps I took to differentiate the symptoms and to understand their mechanism, but I propose to describe at some length how I proceeded to investigate their prognostic significance. This subject has been neglected because those engaged in research do not have its importance thrust upon them. On the other hand, experience had shown me that for intelligent practice this matter was essential, and that these two other fields were but preparatory for this, which is indeed the coping stone of all medical investigation.

As time has gone on I find that the conception of prognosis grew upon me till I now recognize it as the vital spark which endows medical investigation with life and interest, and that what rendered so much endeavour vain and futile was the absence of this life-giving conception. So far no one seems to have realized that this important field was necessary to the completion of all research in medicine.

Prognosis in Heart Affections.

Guided by these rules, I continued the study of affections of the heart. The methods necessary to differentiate symptoms and study their mechanism were comparatively easy to discover, but it was a long time before it became clear how to proceed with the inquiry into prognosis. At last I put to myself the question, "What are you afraid of?" The reply was "Heart failure." The next question then arose, "What is heart failure, and what are the symptoms by which it can be recognized?"

Were murmurs and irregularities signs of heart failure? I had to confess that, except in certain forms of heart failure where dropsy and dyspnoea occurred, I had no idea of the signs of heart failure. Again I turned to my text-books—clinical, physiological, and pathological—for a description of the signs of heart failure, and again discovered that the knowledge did not exist. I recognized that until I knew the signs of heart failure I was incompetent to study the prognostic significance of heart affections. So I set about to acquire this knowledge and spent years in the quest. Though far from completed, I gained knowledge sufficient to enable me to recognize the importance of the subject and how it should be investigated.

Let me explain how this was done. I had first to watch, in people with failing hearts, the appearance of symptoms, and re-educate myself in the examination of the patient so as to differentiate the symptoms clearly.

This, to a certain extent, had been done in regard to murmurs and modified sounds, but the equally common symptom of irregularity had been neglected. After many years I was able to differentiate the irregularities. I had also to study with care the sensations of the patient, for, as I ultimately found, this was the key which brought the solution of the problem. I thus found out the sensations that indicated heart failure. I found, among other things, that the first signs of heart failure were not to be detected in the heart itself, but were shown in the disturbed function of organs remote from the heart. Then I had to see people before the heart was affected; I had to watch the circumstances that weakened the heart; I had to see the effects of hard work, of pregnancy, of intercurrent diseases,

and I had to detect the onset of the earliest sign and watch the progress till death. I had to find out the mechanism by which the various symptoms were produced, and to do this I had frequently to resort to the physiologist for help. By the knowledge thus acquired I was able to distinguish those signs which were of significance from those which were of no significance. It will be seen that to understand the subject of prognosis the observer has first to undertake a long training, and then he has to have the opportunity of studying not only acute cases, but cases that proceed gradually for ten or twenty years or longer.

It is impossible for those who have not undertaken this kind of research to understand its difficulties. Let me describe one phase of the subject. One object I had in mind was to understand where lay the danger of pregnancy in a woman with a damaged heart. This is a problem which confronts, time and again, every general practitioner, and it is one of very serious moment to those concerned. The references to this subject in the most recent books on obstetrics have not advanced beyond those published over forty years ago. To undertake this part of the inquiry I had, as I have said, first to train myself to detect the early signs of heart failure. Then I had to study the changes in the circulation and search for the causes producing them, during pregnancy, during confinement, and during the puerperium which occurred in healthy women; I had to watch the changes that took place in women with different forms of heart disease, examining them before pregnancy and at all the subsequent stages. This meant attending them during labour, taking careful observations during the pains and when free from the pains. These observations were not made in a comfortable ward with plenty of help, but often after a hard day's work, during the night in poor cottages, where I had to do the duties of the doctor and nurse, give chloroform, apply the forceps. Yet this work had to be done, and in no other way could the knowledge be acquired.

It will be seen that a matter like prognosis, so essential to medical practice, requires methods and opportunities of a particular kind, but so backward is the state of medicine that neither the methods for acquiring this knowledge nor the value of the knowledge when acquired is understood.

Guiding Principles in Prognosis.

It was necessary not only to seize the opportunity and make a note of symptoms, but to have a clear guiding principle. I want you to grasp this point, for it was the want of this principle that caused me to spend years in "muck-raking." I remember examining repeatedly a man suffering from angina pectoris and failing to detect any physical sign of disease, yet he could not walk 200 yards without being pulled up by an excruciating pain. When he died I found the myocardium extremely atrophied and the coronary arteries blocked. I saw that this condition must have been coming on for many years, and this caused me to reflect on the effects of the damaged muscle. When the man was at rest he was quite well, mentally active, and complained of nothing, but when he made an effort he was pulled up. So I dimly conceived that the symptoms were only produced in response to effort. Then I considered the nature of the heart's functions, and recognized that the muscle force of the heart could be considered as being of two kinds, one to maintain the circulation when the body was at rest, and the other a reserve force, called into play when an effort was made. On reflection I recognized that the first sign of heart failure was bound to be a diminution of this reserve force, and that the earliest symptoms of heart failure would be shown in a response to effort.

I therefore made a long investigation into this response to effort, considering first what happened to people in health. In childhood the response to effort is small, for the child stops after running a few yards. In boyhood it is much greater, and reaches its greatest amount in the heyday of youthful vigour; after that it gradually declines till the old man reaches the limits of his childhood. I compared these results with what happened in disease, and found that the response to effort was restricted in exactly the same way. Then I asked, What are the signs of this limitation? And for a time, being under the delusion that instruments were the most scientific method, I spent much time in recording the rate of the heart, and studying the changes in the character of the pulse by graphic records

and blood-pressure instruments. These did not help. Then it occurred to me to ask of the individual, healthy and ailing, "Why have you to stop," and they all replied, "Because of a feeling of distress." This gave a new turn to my inquiry, and I then investigated this sensation of distress. At first it was difficult to get a clear conception, for I was too ignorant to ask the suitable questions and too ignorant to interpret the answer. After a time I got a little understanding, and gradually the nature of the distress became perfectly clear. The reason why I failed, and, indeed, why the medical world fails to-day, to understand the symptoms of heart failure is because of their extreme simplicity. When we search for the recedite and the obscure we fail to recognize the simple and the obvious.

The sensations of distress which indicate the limitation of the heart's power are of two kinds—breathlessness with its associated phenomena, and pain with its associated phenomena. When you come to think of it, a failing organ does not itself necessarily show its impaired efficiency; rather the symptoms will be shown by the organs which are affected by the diseased organ's failure. Health is the harmonious working of all the organs. The disordered or impaired function of one organ upsets the others, and the signs of ill health are found, not in the inefficient organ, but in the others.

The Estimation of the Functional Efficiency of Organs.

That is a principle which is of universal application, and should be applied to the study of the functional efficiency of every organ.

In regard to the heart, its failure affected structures which did not receive a sufficient supply of pure blood. The respiratory system is the most sensitive, and possesses a mechanism which causes distress when its blood supply is inefficient—so we get breathlessness. The heart muscle, when forced to increased effort, requires more blood, and if it fails to receive an adequate supply it gives expression to its exhaustion by pain, a symptom belonging to the nervous system.

I cannot here explain the steps by which this conclusion was reached, nor show you what a flood of light it has thrown upon that darkest of fields in medicine—the evidences of functional inefficiency of organs. While for many years I have used this knowledge in practice, the full meaning of it was not understood until, in St. Andrews, we had carried the inquiry further, and discovered the mechanism by which such symptoms and the vast majority of other symptoms were produced.

If you reflect, common sense will tell you that the response to effort is the only means by which the efficiency of the heart can be recognized. It is now many years since I called attention to it, yet its significance is not grasped. You can see this failure to grasp it in the medical forms for life insurance. Questions are asked about the size of the heart and its sounds, its rate and its rhythm, but not a single question as to the response to effort. Some companies have an elaborate series of questions for suspected hearts, but in none of these is there any reference to its functional efficiency. People are to-day rejected for life insurance or penalized because of an innocent murmur and irregularity—a mistake which would never occur if insurance examiners understood the response to effort. Other people are passed as fit who would never be accepted if the answer to a simple question was skilfully interpreted. I have on many occasions been consulted by men who had a few months before been insured for large sums, who suffered from such advanced disease of the heart that they died shortly after. There was no physical sign, but their replies to my inquiries as to their response to effort revealed the extreme gravity of their condition.

It requires much experience to use this method, but when the knowledge is acquired it is easy. The testing of a patient by hopping about a room and counting his pulse and taking his blood pressure cannot reveal this information; it is got from the patient's experience when the heart is called upon to do its usual work—such as walking up a hill after a meal, walking in the cold air, and so forth. The reason I mention this is to indicate that artificial tests do not bring out the qualities of an organ, neither in the case of the heart, of the stomach, of the kidney, or of any other organ.

The Misunderstanding of Prognosis.

The lack of understanding of the importance of prognosis comes out in striking and curious ways. A great many people have been engaged in the investigation of irregular heart action, and much of the mechanism has been revealed; but they stop there, being content with the recognition of the different forms of abnormal heart action. To me, on the other hand, this research was but a means to an end, not the end itself—the end being the prognostic significance of the irregularities.

Here is a curious matter. I have received a meed of praise far beyond my deserts for the employment of mechanical methods in general practice. Indeed, I do not doubt that is the reason why I have been honoured to address you to-day, and I have been told that this was the reason I was made F.R.S. That implies a limited outlook upon medicine. The use of these graphic methods was but child's play to the search for the significance of irregular heart action. If you could but grasp what that long search meant—the difficulties to be overcome, the taking up of methods and finding them unfit, the constant study of the patient, the search in literature for all sorts of knowledge that might help—you would realize how heavy was the task and how infinitely more important was the result. And yet, gentlemen, though I have been praised and honoured for the easy task of record-taking, nowhere have I seen any recognition or understanding of what I may say has been the chief object of my life's work.

The Keeping of Records.

Did it ever occur to you why records of patients are kept? Every hospital keeps them as a routine, but it is doubtful if the reasons are understood. The chief purpose of records is to lay the basis of prognosis—that is, to obtain a knowledge of a patient's complaint from data drawn from patients presenting similar symptoms whose progress has been observed. The real purpose of records is to show this progress. They can be used for other purposes, but these are subsidiary. To-day they fail in usefulness because of the absence of a knowledge of prognosis. If you consider the enormous amount of record-taking and record-keeping in all the hospitals and private note-books in the world, with the enormous number of life insurance records, and reflect that if one wished to know what was the significance of some simple sign, such as a heart murmur or irregularity, the information could not be obtained, you will appreciate the futility of record-taking as understood to-day. The records taken to-day are not a bit more helpful than those taken fifty years ago. I know this will be disputed, for there is a belief that medicine has made such gigantic strides that signs and symptoms are now detected that were never before recognized. Thus a physician who has had some laboratory training in biochemistry includes in his notes the chemical constitution of some fluid. Another who has studied the blood will reflect his speciality in his records. If he has studied bacteriology the records will describe the various bacteria found, while blood pressure records and electro-cardiograms will show the bent of others, and so on. Each one finds his justification in the belief that in recording facts he is adding to the sum of human knowledge, whereas he is but adding to that enormous mass of chaotic details which darkens and confuses medicine to-day.

The Purpose of Records.

The real purpose of record-taking is to relate the life-history of disease in a number of people so that the signs which reveal the disease and show its progress and those which indicate danger can be recognized.

Prognosis is the motive which inspires note-taking with the breath of life, making the notes a perennial source of knowledge that can be applied in the practice of medicine. To obtain records of value, opportunity must be had of seeing disease from its onset till its end, while knowledge of a particular kind is required in order that out of the mass of symptoms those that are essential only are recorded.

While that is the ideal, only those who have recognized it and have striven to attain it understand its difficulties. This ideal, it is to be observed, differs greatly from the practice of to-day when there is too often but a dreary record of undigested symptoms during a passing phase of disease.

The Records of Mitral Stenosis.

In order to convey some idea of the method and purpose of record-taking, let me cite my observations on mitral stenosis. It is over fifty years since the presystolic murmur was recognized as indicating stenosis of the mitral valve. If you turn to most textbooks you will find that since that day no progress has been made in our knowledge of this murmur, or indeed of any other murmur—that is to say, for fifty years auscultation has not progressed, and notwithstanding all the alert minds that have been engaged in clinical medicine, no conception existed as to how progress should be made. But as soon as I was possessed of the idea to find what happens to the individual with a presystolic murmur, new life was breathed into my work, and a way of progress opened up.

Early in my career as a general practitioner I found that the presence of mitral stenosis was associated with danger to pregnant women as well as to others. It was necessary to know wherein lay the danger. To understand this it was necessary to know the life-history of people with this trouble. I therefore began a series of observations on patients with rheumatic fever or who had had rheumatic fever. I kept in contact with them for many years, and watched the progressive changes that took place in the sounds of the heart. In this way I discovered that the murmur peculiar to mitral stenosis—the presystolic—did not occur during the causative attack but at variable times afterwards—usually several years. The murmur at first was short in duration and was not always present. As time went on it became of longer duration and constant. By and by another murmur appeared, diastolic in time. This increased in length until it ran into the presystolic, so that during the diastole of the ventricle there was a continuous murmur. When such patients died the mitral orifice was reduced to a mere slit. One infers that the cicatrizing process is gradual, and that these changes in the murmur are due to increase of the cicatrizing process which narrows the orifice. But the point of importance is that you are given an idea of the stage of narrowing that has been reached. Moreover, the rate of progress varies greatly; some only reach a certain stage and remain stationary. The recognition of this gives a further guide to prognosis. It is necessary, for instance, in advising as to a woman's fitness for child-bearing to know whether the stenosis is stationary or advancing rapidly, and this knowledge is obtained by recognizing the peculiar features of the murmur, whether short or long, or whether a diastolic murmur is present, with a knowledge of the time of the causal attack. Thus, a short presystolic murmur with a history of rheumatic fever ten or fifteen years before would indicate a favourable prognosis, while a presystolic and diastolic murmur with a history of four or five years would give a much graver outlook. To-day, amongst obstetric physicians, there is much confusion, for, while one group says mitral stenosis is a very dangerous complication, others declare it not to be of serious significance, the reason being that each speaks of the cases that come within his own experience, none recognizing the principle that should guide them.

But in this inquiry I was struck with the great diversity of phenomena that arose. Thus some patients suffered from severe heart failure and died while yet the stenosis was slight in degree. Others pursued laborious occupations when the stenosis was far advanced. I therefore recognized that there were other factors, the chief of which I found to be a coincident damage to the heart muscle. Sometimes this could be made out by the changes in the size of the heart, or by the presence of partial heart-block, but the most instructive indication was the response to effort. This meant that the mitral stenosis was but one factor in assessing the functional efficiency of the heart, and that it was necessary to consider the associated phenomena and particularly the response to effort.

Many instructive phenomena, which explained features that had puzzled clinical observers (to some of these I will refer later), came under notice during this research. But the most striking and most dramatic was the sudden onset of extreme heart failure that every now and again overtook some of these patients. One, whom I had watched for seventeen years, and who had lived a useful and industrious life as a nurse, was suddenly seized with great breathlessness, and the heart became rapid in its rate and dilated. She was cyanosed, the liver was enlarged, and dropsy set in. On taking graphic records I found that the

rhythm was very irregular and the auricular wave had disappeared from the jugular and liver pulses. On listening to the heart the presystolic murmur, which had been present, had disappeared. Thus all signs of auricular activity had disappeared.

My attention being arrested by these signs I sought for similar conditions and found that these cases were frequent and occurred independent of mitral stenosis, so that I was able to recognize a definite and distinct type among heart cases. Indeed, I found that between 80 and 90 per cent. of cases of heart failure with dropsy and enlarged liver were of this type. I then proceeded to watch these cases to see what happened, and I found that on the onset of this abnormal rhythm the heart failure set in with such severity that some died within a few days, others within a few weeks, others led a crippled existence for months or a few years, while others lived comfortably at a lower level for many years, and in a few the onset was not accompanied by any limitation of the heart power. Seeing these very diverse results I set about a long inquiry into the reasons. I found that in those who did well after the onset, though the heart rhythm became irregular, the rate did not alter. On the other hand, in those who did badly the rate became increased, sometimes greatly. In watching them I found that if the rate slowed the patient improved, so I looked for means for slowing the rate and naturally turned to digitalis. I gave the digitalis at first timidly, as we were brought up to look upon it as a dangerous though useful drug, then more and more boldly, till I found the quantity that would slow the heart. When I had acquired a knowledge of the drug and how to administer it, I was able to give speedily the greatest relief to many patients who were apparently *in extremis*. But I found that as soon as the drug was stopped the patients relapsed, so I set about discovering how to give the drug so as to keep the pulse at a moderate rate, and at last devised a method by which many people who were apparently hopelessly broken down were enabled to resume their occupations.

In some the digitalis or other drugs would not slow the rate, and these invariably drifted and died. In others in whom the heart slowed, the symptoms of heart failure were not relieved—these also speedily sunk and died. The *post-mortem* examination in these cases invariably revealed such extensive damage of the heart muscle that one could infer that such hearts, embarrassed by the abnormal rhythm, were inconsistent with life.

I need not go into the numerous interesting points that arose from this inquiry. One I may mention was that the particular kind of rapid heart for which digitalis is the remedy stood now clearly revealed, as I have already said. If you have grasped the significance of the methods I adopted for getting the prognosis you will at once see what a powerful weapon has been placed in our hands, and with what confidence we are now able to give a clear prognosis based upon accurate observation and sound principles.

Many years after, this condition was discovered from experimental search to be due to fibrillation of the auricle, and it is a curious illustration of the lack of perception of the essentials of medicine that the discovery of this condition is frequently assumed to have occurred only when it was demonstrated in the laboratory. All that work which revealed its clinical symptoms, which laid the basis of a sound prognosis, and which indicated rational lines of treatment, is practically ignored. The research in the laboratory has indeed helped to a partial understanding of the mechanism, and to differentiate this condition from others it resembled, but it has not added one iota to the knowledge necessary to clinical practice. Indeed, so little is the significance of this inquiry realized that in books and articles written by cardiologists you seldom find any appreciation of the basis for a rational treatment, let alone a rational prognosis.

I do not quote this in order to disparage laboratory work or to praise myself, but to demonstrate the blindness to what is essential in medical inquiry—to illustrate the limitations of laboratory investigations into diseased states. While we recognize the presence of auricular fibrillation, we do not know the conditions which induce it, nor is there the slightest expectation that laboratory experiment will reveal it. I have a poor woman who suffers from haemorrhages, which occur spontaneously under the skin. It would not throw any light upon her

ill health to give a man a black eye. It is vain to expect to discover a process of disease by applying to a healthy organ a stimulus of a kind which nature never employs. A disservice is thus done to experimental work, inasmuch as it is asked to reveal that which it cannot reveal.

New Fields Opened up by the Study of Symptoms.

In watching the life-history of patients with mitral stenosis a great number of instructive incidents occurred. By keeping in mind the rules I had adopted of differentiating the symptoms and recognizing their mechanism and their prognostic significance a light was thrown beyond the immediate object of research and opened up other fields of inquiry. There was revealed, for instance, the nature of many functional abnormalities, which could not be shown by experiment or by the study of dead organs. Thus one man whom I attended for rheumatic fever in 1880 was left with a damaged heart and a systolic murmur. It was ten years later before I detected a presystolic murmur. Later I recognized that this murmur became separated from the first sound by a short pause—a feature which had been described as a mid-diastolic murmur. Records of the jugular pulse showed that at the time of this mid-diastolic murmur there was a wave in the jugular vein due to the contraction of the right auricle, and there was an increase in the interval after the wave before the carotid pulse appeared. By-and-by I was able to recognize that this meant a delay in the transmission of the stimulus from the auricle to the ventricle, and from this inferred that the bundle connecting auricle and ventricle had been damaged. So that we can now recognize that a mid-diastolic murmur means not only mitral stenosis but a partial heart-block. With the recognition of this delay between the auricular and ventricular systoles we caught the early stage of that condition which goes by the name of Stokes-Adams syndrome.

But much more was learnt. I had found that one effect of digitalis was to increase this delay, so that at times the stimulus from the auricle failed to reach the ventricle, and a beat would drop out, and this was explained one effect of digitalis that had hitherto baffled interpretation.

The continued observation of this patient revealed other important changes. He used to come and see me every two or three weeks. In April, 1904, I found for the first time that his pulse was irregular. On further examination, I found that the mid-diastolic murmur had disappeared, while the auricular wave also was absent from his jugular tracing—that is to say, all evidence of activity of both auricles had disappeared—the disappearance of the murmur was a sign of cessation of activity of the left auricle, and the disappearance of the wave in the jugular a sign of the cessation of activity of the right auricle.

This condition continued for a week; then one day I found both murmur and auricular wave had returned and the rhythm had become quite regular. The heart continued thus until the following November, when the irregularity returned with the cessation of auricular activity. This condition persisted till his death ten years later.

One instructive point was this: I had observed, as I have said, that when these events happened heart failure usually set in, sometimes speedily. This man was unconscious of the changes, and he continued his laborious work—that of a mechanical engineer—with no signs of heart failure. On seeking for a reason, I found that in his case though the rhythm had become irregular the rate had not increased; both before and after the rate was about 60.

The reason for this was no doubt the presence of the partial heart block. I had recognized that digitalis acted on the bundle and produced heart-block. The cases that did badly and suffered from heart failure after the onset of auricular fibrillation had the rate of the heart greatly increased. It occurred to me, if I could imitate this heart-block by using digitalis, the ventricle in these cases might be kept slow and heart failure prevented. This was found to be correct, and in this way was found that treatment which has robbed auricular fibrillation of much of its peril.

The Basis of a Scientific Therapy.

A matter which strikes everyone who gives it attention is the curious difference between theoretical therapy and practical.

We have the experimental pharmacologist demonstrating

to the student with precision the effects of remedies by animal experiment. The student as soon as he enters the wards of the hospital finds a different atmosphere—drugs are administered without any reference to their experimental effects, and he finds the knowledge he has acquired in his pharmacological course of no use.

The pharmacologist scoffs at the clinician as unscientific and as employing empirical methods. The clinician replies that the laboratory teaching is academic and unpractical.

I have already remarked that the action of digitalis on the human heart was not understood, and when I made the observations on the effects of digitalis during this inquiry into mitral stenosis, I was struck by the variety of results I obtained. In one patient digitalis would produce dropping out of beats due to heart-block; in another it would cause the whole heart to stand still for two or three seconds and then the ventricle would start off by itself; in another great slowing would result, and so on. When I looked at these patients individually, I found they all suffered from damaged hearts, but there were differences in the kind of damage, and I therefore formulated the theory that *the action of digitalis is modified by the nature of the disease*. It is manifest that the pharmacologist could never find this out, and his results were different, therefore, from that of the clinician. On the other hand, the knowledge of heart irregularities was so defective that the clinical observer could not recognize them, but saw that they were different from the description given by the laboratory observer. That is the reason of the failure of the pharmacologist to explain the action of digitalis on the human heart, and the reason why the clinician could not recognize it.

This principle, at first dimly perceived, holds out the possibility of directing therapeutical research on lines based upon sound principles. One of the least creditable fields of knowledge is the therapeutic. While many drugs are usefully employed, it must be confessed that our knowledge of the action of remedies is sadly lacking in accuracy. To this defect must be attributed that wide diversity of opinion as to the action of the simpler remedies and that confusion which bewilders the student. This inquiry into the nature of symptoms led us at St. Andrews to recognize that a great mass of symptoms is due to disturbances of normal reflexes. When a man falls ill, due, say, to the invasion of his body by a microbe, the toxins of this microbe produce the ill health by upsetting the normal reflexes, and we recognize these disturbances in the signs of disease.

The administration of a drug such as atropine acts in the same way by disturbing certain reflexes. Indeed, the effect of atropine may be described as an imitation disease. One of its effects is to paralyse the peripheral ends of the vagus and cause an increase in the heart rate. If digitalis is given it is without effect, because digitalis stimulates the vagus, and under atropine it is paralysed.

In certain infections the heart rate is increased because the toxins act like atropine, and digitalis does not slow the heart because the vagus is paralysed, and that is the reason why digitalis does not slow the heart in a great many febrile and other conditions.

In auricular fibrillation the increased pulse rate is due to a totally different mechanism. Here the ventricles are stimulated to increased rate by a shower of stimuli from the fibrillating auricle. The vagus is unaffected, and so the digitalis, when given, acts as we have seen on the bundle which conveys the stimulus from auricle to ventricle, and it is probably in this way that digitalis is so effective in slowing the heart rate in auricular fibrillation.

The First Step in Investigating Disease.

Many visitors come to see our institute at St. Andrews, and they go away disappointed at what they see. Our work is not spectacular—our chief method is seen to be a general practitioner quietly asking questions of a patient who has little the matter with him. A learned physician one day was being shown over the institute. He came to the general practitioner engaged in his work. He looked at the notes and said, "Ah! applying hospital methods to general practice?" "No," I replied, "we are training ourselves how to examine patients. We find that students are never trained to examine patients so as to fit them for general practice." "Oh, nonsense!" said he; "they are well enough trained." "Well," I replied, "you have been teaching students at least for twenty-five years?"

"Yes," he said. Then I asked him: "Can you tell me the symptom of which the majority of people complain when they fall sick?" After some consideration he said, "No." I said, "The most common complaint is exhaustion. Can you tell me what is exhaustion?" He again, after a little consideration, said "No." "So," I said, "here is a symptom of the most common kind, a symptom which, when understood, throws a flood of light upon the patient's state, and yet you, who reckon to be able to teach students how to examine patients, have never given it the slightest consideration." I quote this incident to show what should be the first step in investigating disease, and the only individual whose opportunity permits him to take it. The necessity that the general practitioner should participate in other fields of research is obvious as soon as a real perception of medical research is obtained.

I know quite well that these views at present will fail to carry conviction. All I wish you to do is to pause from time to time and ask whether they are true.

INFECTIVE ARTHRITIS AND ALLIED CONDITIONS :

WITH SPECIAL REFERENCE TO ETIOLOGY
AND TREATMENT.*

BY

W. H. WILLCOX, C.B., C.M.G., M.D., F.R.C.P.,

PHYSICIAN TO ST. MARY'S HOSPITAL, LONDON.

[With Special Plate.]

EVERY practitioner sees daily many sufferers from some or other variety of the numerous conditions included under the term "chronic rheumatism," and it will be agreed that the picture of chronic rheumatic complaints has altered somewhat since 1914. For example, owing partly to the restrictions upon food and drink, pure gout has become an extremely rare disease. On the other hand, there has certainly been no diminution in the frequency of occurrence of arthritis in its non-specific forms or of the various types of fibrositis, perineuritis, and allied conditions. These form a large, and many think an increasing, proportion of the cases of disabling illness.

The object of this paper is to endeavour to throw some light on the causation of these many forms of chronic rheumatism of doubtful etiology, and to indicate the lines of investigation and treatment which are most productive of good results not only for existing attacks, but in the prevention of recurrences.

ETIOLOGICAL FACTORS.

Much has been written about the causes of chronic rheumatic affections, but the majority of these can only be regarded as predisposing conditions and not as true causes.

Sex has been regarded as a predisposing factor in the causation of infective arthritis, the frequency in females being stated to be something like four times that in males. I do not think that this difference holds with regard to the allied conditions—namely, the various forms of fibrositis—for it has been my experience that their incidence greatly preponderates amongst males.

Age.—While infective arthritis is rare under ten years, all ages are susceptible. Dr. G. F. Still described a form of infective arthritis occurring in children of early years, eight of his first twelve published cases occurring under the age of 3. From the age of 20 years infective arthritis has a relatively large incidence for all ages, and the small numbers given for advanced ages are to be explained by the small population from which they are drawn at these periods of life.

Race.—Arthritis and allied conditions have a lower incidence rate amongst coloured than white races. Osler and McCrae, in their American statistics, have alluded to the relative immunity of the negro race. My experience amongst large numbers of Indian troops in Mesopotamia was that arthritis and chronic rheumatic conditions were very uncommon.

Family History.—A family history of arthritis is commonly obtained from sufferers. It does not appear that the disease is hereditary, but it seems likely that there is inherited a tendency for the joints or fibrous tissues to be affected when a person is subjected to an exciting infective cause. Thus, a streptococcal infection may in one person give rise to chronic arthritis, while in another a severe anaemia or an infective endocarditis may result.

Mental strain and debility, by lowering the general resistance, predispose, if the exciting infective cause is present.

Trauma and physical strain can cause an arthritis or fibrositis, but this condition will not be progressive unless some infective cause-condition is present at the time of the injury. It is well known that an injury is often the starting point of a progressive arthritis, and this is commonly the case in osteo-arthritis of the hip-joint. Similarly an attack of lumbago often follows the lifting of a heavy weight or some undue strain of that kind.

Exposure to cold, wet and damp, and the living in houses without proper damp-proof courses, particularly in districts where the subsoil is damp and the subsoil water high, all act as predisposing causes.

Pregnancy and parturition are sometimes followed by a non-specific infective arthritis. It is well known that an existing infection in the body—for example, pulmonary tuberculosis—often undergoes a rapid development as the result of pregnancy, and in a similar way a latent streptococcal or other infection may be set up and cause a non-specific infective arthritis. This is the probable explanation of the etiological bearing of pregnancy on arthritis.

Disease of the nervous system is not associated with infective arthritis or the various forms of fibrositis. The changes seen in the so-called Charcot's joints of tabes or syringomyelia are due to trophic changes from spinal cord disease, which, together often with trauma, lead to severe organic changes in the affected joints.

Faulty Metabolism.—For many years dietetic errors in food and drink held sway as supposed exciting causes. Excess of protein in the dietary, the taking of alcoholic beverages such as certain wines and beer, the taking of acid fruits, were all thought to play an important part. The modern view is that metabolic factors have little or no influence in the causation of infective arthritis. In the allied conditions, such as the various forms of fibrositis, some regulation of the diet is advisable in plethoric patients, but the true cause is not to be found in dietetic errors. Undoubtedly metabolic factors play an important part in the causation of true gout where the accumulation of uric acid and allied substances in the system acts as an exciting cause.

Rheumatic Fever.—This must be regarded as quite distinct from the diseases under consideration, and the various manifestations of acute rheumatism are well known and form a special clinical entity. There does not appear to be any definite association between rheumatic fever and infective arthritis, though not infrequently cases of infective arthritis are seen in which there is a past history of one or more attacks of rheumatic fever which have been associated with definite valvular lesions.

Infective Causes.—The conclusion which forces itself upon one from a close study of cases of non-specific infective arthritis and allied conditions is that the real exciting cause is an infection, the continued absorption of toxic substances giving rise to the inflammatory changes in the joints and fibrous tissues. It has been my experience that in the great majority of these cases a streptococcal infection from some focus in the body is the exciting cause, though in some cases another organism may cause similar effects—for example, the *Bacillus coli communis* group of bacteria.

Arthritis from specific infections is well known—for example, gonorrhoea may give rise to arthritis and inflammations of tendons and fibrous tissues generally, and the specific organism has frequently been obtained from the fluid of affected joints. Bacillary dysentery is well known to be sometimes associated with arthritis, and the specific organism has on some occasions been obtained from the fluid of the affected joint. As in the case of gonorrhoea the tendons and fibrous tissues generally may be involved, and a conjunctivitis has been observed in both these specific forms of arthritis. Scarlet fever is well known to be frequently complicated by an

* A lecture delivered to the Derby Division of the British Medical Association on February 8th, 1921.

arthritis and fibrositis. Malta fever, typhoid, and paratyphoid fever sometimes give rise to a specific arthritis or fibrositis. Pneumonia and pneumococcal infections have on many occasions been complicated by an acute arthritis, the organism being obtained from the joint effusion. Tuberculosis and syphilis are well known as the causes of a specific arthritis. Acute septicaemia and pyaemia are sometimes accompanied by suppurative arthritis. Indeed, it may be said that almost all the known infectious diseases may be accompanied by an arthritis or fibrositis, due no doubt to the specific infection of the disease. I have seen the most intense periosteal pain and tenderness occur in a patient affected with glanders, and in this case a painful swelling occurred in the tendon of the gastrocnemius muscle, which on being opened was found to contain the bacillus of glanders.

Arthritis of known causation may be classified thus:

1. Traumatic.
2. Arthritis due to the specific infection of known diseases as already enumerated, in which should be included rheumatic fever.
3. Gout.
4. Arthritis following the injections of animal serums—for example, antidyserteric serum, antidiphtherial serum, in which case a joint effusion occurs without permanent organic changes in the joint structure.
5. Arthritis of neuropathic type due to diseases of the spinal cord, such as tabes dorsalis, syringomyelia.
6. Arthritis associated with (a) haemophilia, when an effusion of blood occurs into the joint, or (b) scurvy, when a sero-sanguineous effusion occurs in the joint and joint structures.

The above forms of arthritis are excluded from consideration in this paper, and there remains the very large group of cases which have been described under the terms:

- Rheumatoid arthritis.
- Arthritis deformans.
- Osteo-arthritis.
- Chronic villous arthritis.

Each of these is in all probability due to an infective cause of non-specific origin. Though typical cases of each group differ in their morbid appearances, yet great similarities are present in all, and a case belonging in its early stages to one group may in its later stages develop into another. For example, a case of rheumatoid arthritis, or of villous arthritis, may in the later stages of the disease develop the typical bone changes of osteo-arthritis. These types of arthritis are all included under the one heading, non-specific infective arthritis.

Of similar etiology and often associated in occurrence are the various forms of fibrositis—namely:

- Panniculitis, inflammatory conditions of fasciae and aponeuroses, as occurs in lumbago and myalgic conditions.
- Inflammations of tendons and ligaments, such as stiff-neck, tender heels due to involvement of the plantar ligaments, Dupuytren's contractures of the palmar fascia.
- Inflammations of tendon sheaths, as in teno-synovitis.
- Bursitis.
- Heberden's nodes.
- Finger pads.
- Fibrous nodules in subcutaneous tissue.
- Local perineuritis and neuritis, as in sciatica, brachial neuritis.

PATHOLOGY.

The above conditions, when not associated with a general specific infection, are, I believe, in all cases due to some localized infection of the body, generally of a streptococcal nature. The organism causing the infection cannot usually be obtained from the affected joint or tissue, and in all probability the pathological changes are due to the toxins absorbed. A very large number of bacteriological examinations of the affected joints have been made by numerous skilled observers, but no specific organism has been found, and generally the results have been negative. In a few cases a streptococcus or a bacillus has been found in the affected joints, but proof has generally been wanting that this organism was the primary cause of the arthritis in question.

Poynton and Paine isolated from one case of infective arthritis a streptococcus, which caused similar lesions in rabbits. It appears probable that in the majority of cases the affected joints and tissues are devoid of living bacteria. This is not surprising, since the causal infection is often of a relatively low type of virulence and often far distant from the affected joints. Analogous examples are the

pleurisy with sterile effusion frequently found over a sub-phrenic abscess containing pathogenic organisms.

I have this year seen a striking example of a very acute inflammation without any bacterial infection, caused by the bacterial infection of a neighbouring organ.

A patient was attacked with an acute empyema of the right pleural cavity and a heavy infection of streptococci was found. The empyema was opened and drained, but an acute pericarditis with effusion was also present, and three weeks later the pericardium was opened. It was found to be in a state of acute inflammation, with much clear effusion and early adhesions. The pericarditis fluid contained no organisms and was quite sterile on culture.

The cause of an infective arthritis should always be sought for. A careful clinical examination of all the organs should be made, but frequently no apparent cause is visible.

Infection from Teeth.—The commonest cause of infection is to be found in connexion with the teeth sockets. Dr. Beddard in October, 1918 (*Transactions, Medical Society of London*), placed 90 per cent. of cases of so-called rheumatoid arthritis in this category, and my personal experience agrees with this view. Very commonly the teeth and gums appear healthy, and give rise to little suspicion even after a close examination, but sometimes there may be visual evidence of caries and gingivitis, and on pressure pus may be expressed from the space between the gum and the teeth. It cannot be too clearly realized that the infection which is most likely to be the cause of an arthritis and allied conditions is often deeply seated near the apex of the tooth and gives rise to no symptoms whatever, and pain, swelling and tenderness may be entirely absent. The only certain method of examination of the tooth sockets is by means of *x* rays; this should be done in every case, photographs of the individual teeth being taken. Usually there is definite evidence of osteitis with rarefaction or destruction of the alveolus, and the most striking evidence of all is the indication of an apical abscess shown in the print by the clear white space deep to the apex of the tooth. This space is invariably filled with pus and granulations heavily infected with pathogenic streptococci and must serve as a constant supply of virulent toxins, if not of bacteria, into the blood stream. On very many occasions I have found this condition associated with infective arthritis, and the various forms of fibrositis. In one case under my care an abscess of this kind was the undoubted cause of malignant endocarditis, an identical organism being found in the blood stream and dental abscess. During the last eighteen months I have seen four cases of infective endocarditis in which the infection undoubtedly arose from pyorrhoea alveolaris.

Dr. Bertram Watson, in the *Lancet* of January 1st, 1921, has called attention to the numerous pathological conditions in addition to arthritis and fibrositis arising from apical dental infection, such as iritis, iridocyclitis, retrobulbar optic neuritis, dyspepsia, and skin eruptions. The association of severe secondary and pernicious anaemia with dental infections is well known from the work of Hunter. Recent work by Rosenow and others in America has shown that the cause of gastric and duodenal ulcer is often to be found in dental infections. It seems probable that appendicitis, cholelithiasis, and colitis may in some instances be traced to the same cause. The accompanying prints (see Special Plate) from *x* ray photographs of teeth taken by Mr. C. A. Clark, M.R.C.S., L.R.C.P., L.D.S., illustrate some of the pathological conditions commonly found in cases of non-specific infective arthritis and allied conditions.

Intestinal Infections.—Where arthritis is present, and a dental origin is discovered, almost always streptococci showing similar bacteriological characters are found in profusion in the faeces, and in cases of progressive arthritis after all the teeth have been removed there is usually found bacteriological evidence of a marked streptococcal intestinal infection. Intestinal infections may, apart from dental infections, give rise to arthritis, but in such cases there is generally evidence of attacks of entero-colitis with diarrhoea and loose stools containing mucus. The causation of dysenteric arthritis by bacillary dysentery has been mentioned. In this country intestinal infections are uncommon primary infective causes of arthritis.

Tonsils and Adenoids.—A septic condition of these organs, of streptococcal type, may give rise to arthritis and allied conditions. A careful examination of the tonsils should always be made, and if unhealthy-looking, pressure should be applied to see if pus can be expressed.

The maxillary antra and nasal sinuses should be carefully examined by illumination, etc., for a possible source of infection. The uterus and genital organs also should be examined for possible sources of infection. In my experience infections from these organs apart from gonorrhoea are very rarely the cause of arthritis and allied conditions. Any focus of suppuration may act as the cause of a general infective arthritis; thus infected wounds or a suppurating joint may give rise to a non-suppurating general arthritis. (McCrae.)

MORBID ANATOMY.

The morbid changes in the joints in this condition have been described by Strangeways and others. Briefly, they consist of swelling and hyperaemia of the synovial membrane, and in the villous form this may attain a high degree of proliferation. The fluid in the joint is slightly turbid from the presence of small fibrous deposits, and usually contains lymphocytes and a few polynuclear cells. Later the capsule of the joint becomes involved, and inflammatory processes are set up which may go on to thickening and contraction. The cartilage of the joint becomes affected, the surface being roughened and irregular with small elevations, and a fibrous tissue degeneration involves it with blood vessels spreading through. The cartilage becomes thinned and may almost entirely disappear.

Atrophic changes occur in the bones and the density becomes diminished. At the apposed surfaces absorption occurs in advanced cases, and at the periphery osteophytic outgrowths of softish bone occur so that a mushroom appearance may be produced. In the synovial fringes thickened fibrous nodules partly calcified may develop, and these sometimes become dislodged, forming loose bodies in the joint. In extreme cases a fibrous or partly bony ankylosis may result.

The changes to be seen in x-ray photographs are rarefaction of the involved bone, a fuzziness of the articular surface, as if a very thin layer of fine cotton-wool covered them, due to the irregularity of the surface of the bone in consequence of the changes described. The clear space between the opposed bones is diminished as a result of cartilage absorption. Loose osteophytes may be seen in some cases. Lipping of the bones or slight outgrowths may be seen.

SYMPTOMS AND PHYSICAL SIGNS.

It cannot be too strongly insisted upon that the most careful examination must be made to determine exactly what structures are affected. Each joint should be carefully examined for evidence of swelling, pain on movement, crepitation, creaking or grating.

A careful examination should be made of the bursae around the joints, of the tendons, and the tendon sheaths.

Wasting of the muscles above and below an affected joint is sure to be present in arthritis of appreciable duration, and where the hands and feet are involved trophic changes, such as sweating, pallor and thinning of the skin, and defective circulation, are usually present. The freedom of movement in all directions of each joint should be carefully tested and any limitation noticed.

When there are symptoms of fibrositis a close examination should be made to determine whether the fasciae, muscles, tendons, or nerve trunks are involved. Pressure should be made on the affected part, and where brachial neuritis or sciatica is suspected the nerve trunks should be pressed upon to see if tenderness is elicited, and movements of the limbs made which will put on stretch the nerve trunks, and so elicit marked pain if they are affected.

It is not proposed to give in detail the signs and symptoms of infective arthritis. Some cases begin with an acute onset of pyrexia and general in addition to the local symptoms. Undoubtedly cases of infective arthritis occur which completely clear up with rest and treatment after an attack of moderate duration. Generally, however, the condition is progressive, and unless the cause of the disease is removed no permanent improvement will result.

In the majority of cases of arthritis the onset is insidious and gradual, a localized pain and swelling in an affected joint or joints occurs, and this progresses, other joints being involved, usually in a comparatively symmetrical manner. The involvement of the joints is usually accompanied by general pains, described as rheumatic in nature,

and no fever may occur, though malaise, depression, headaches, anaemia, and debility are usual. Cardiac complications are absent as a rule, and beyond the joint affections, and the general malaise and ill health often associated with marked wasting, little is found. The tendon reflexes over affected joints are usually exaggerated, owing to the excitability of the reflex nervous are caused thereby. The temporo-maxillary joint is involved much more often in infective arthritis, and this is an important point in diagnosis. The earliest joints involved are often the metacarpal joints of the thumb and the phalangeal or metacarpal or carpal joints of the hands, but any joint may be primarily affected.

Heberden's nodes, the fibrous enlargements on each side of the distal ends of the second phalanges of the hands, are often present in cases of infective arthritis. Osler states that these are rarely associated with serious involvement of the larger joints, with which my experience entirely agrees. A hopeful feature of them is that they have been regarded as a sign of longevity.

TREATMENT.

The most important step is first to find out the cause of the infection which has given rise to the arthritis. The measures to be adopted have been already indicated. A careful and complete clinical examination should be made to find out any possible source of infection, and this should be supplemented by an x-ray examination of the teeth and bacteriological examination of the stools and urine.

In acute cases with pyrexia absolute rest in bed is essential and complete rest of the affected joints. Local applications of heat, such as electric-light baths, or fomentations, iodine poultices, etc., are of value. Salicylates, which are of such striking benefit in rheumatic fever, are of little value. Indeed, drugs, except for the relief of pain—such as pyramidon and phenacetin—are not of much use. Intestinal antiseptics—such as guaiacol carbonate gr.x t.d.s. or cyllin miii—should be given. A new intestinal antiseptic, "dimol," which is said to have fifteen times the disinfecting power of phenol and to be non-toxic, may be given in doses of 2 to 4 grains in keratin capsules three times daily. Bier's treatment is of value until the exciting cause has been determined; an elastic bandage is placed round the limb above the affected joint so as to obstruct the veins but not the arteries, and is left on for twenty minutes daily.

In cases without pyrexia, if there are signs of active inflammation in the joint, such as redness, heat, swelling, or pain, rest of the joint is essential, and local and general treatment as above should be prescribed. Iodine is of value. Collosol iodine in doses of 1 to 2 drachms with a wineglassful of water should be given twice daily. Iodides, if tolerated, may be given instead.

As soon as the source of infection is found this should be eradicated if possible. Where the teeth are implicated or an apical dental infection is found, the affected teeth should be removed and placed in a sterile vessel for bacteriological examination. A satisfactory way of dealing with an apical infection is Gardner's method of sterilizing the infected bone area by removal of the alveolar layer over the site of the lesion and curetting away the diseased tissue, and sterilization after removal of the offending tooth. This involves a cutting operation over the gum of the affected part.

Vaccine Treatment.—This is of great value, but it cannot be too strongly insisted upon that it must be accompanied by removal of the causal infections. Affected teeth should be removed, and a vaccine prepared after guarding against possible contamination of the teeth removed with normal streptococcal organism found in the mouth. A course of at least three months of vaccine treatment is usually required, with weekly and later fortnightly doses. It is a wise procedure to have a bacteriological examination of the faeces made, even if a dental streptococcal infection has been found. Usually an abnormal streptococcal intestinal infection is also present in such cases. It is then an advantage to use for treatment a combined vaccine made with equal proportions of the dental and intestinal streptococci. In cases where the teeth have been removed and arthritis still persists, an examination of the faeces or colon washings will usually indicate a streptococcal infection, and in such cases vaccine treatment may give benefit.

W. H. WILLCOX - INFECTIVE ARTHRITIS AND ALLIED CONDITIONS.

8-62



FIG. 1.—Apical abscesses in upper premolars.

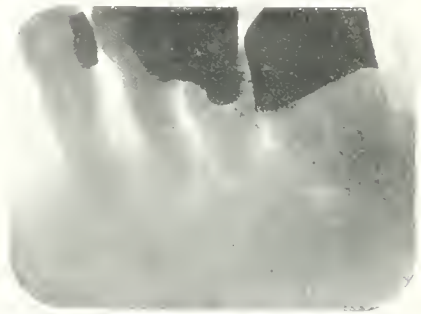

FIG. 2.—Marked loss of alveolus due to pyorrhoea; apical abscesses on both roots of first lower molar and on anterior root of second molar.

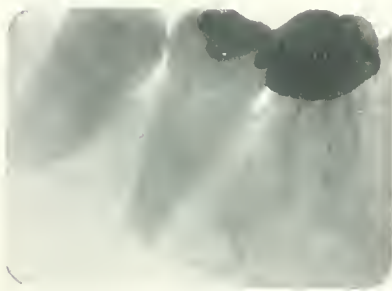

FIG. 3.—Apical abscess on first lower molar—both roots.



FIG. 4.—Marked loss of alveolus due to pyorrhoea; apical abscess of lower premolar.



FIG. 5.—Apical abscess of premolar of upper jaw, close to floor of antrum.



FIG. 6.—Apical abscess of lower premolar.

J. P. LOCKHART-MUMMERY: COCCYGEAL FISTULAE.

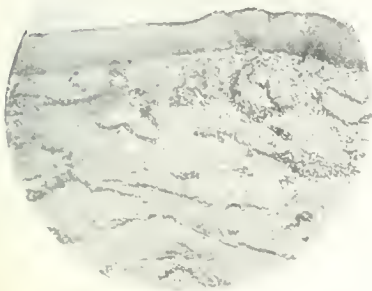

FIG. 1.—Section of wall of fistula showing epithelial lining.



FIG. 2.—Wall of fistulous track showing epithelium and giant cells.

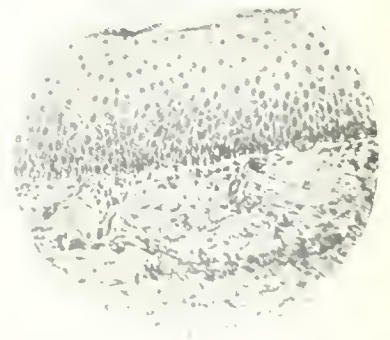

FIG. 3.—High power view of epithelial wall of fistula.

A. MITCHELL: ACUTE OSTEOMYELITIS OF THE LONG BONES IN CHILDREN.

From a case in which subperiosteal resection of the tibia was performed on November 30th, 1919.



FIG. 1.—Showing the amount of regeneration that has taken place at three months after operation.



FIG. 2.—Showing amount of regeneration at four months after operation.



FIG. 3.—Photograph of the leg seven months after operation. The tibia is firm and strong and the range of movement in the knee and ankle joints is almost equal to normal.

H. S. CARTER AND W. FLEMING: IDIOPATHIC MUSCULAR DYSTROPHY.



FIG. 1.—Showing the marked lordosis in the erect posture, and the flattening of the chest.



FIG. 2.—Showing the atrophy of the thighs, the enlarged ten- or fasciae femoris muscles, the early "taille de guêpe," and the flattening of the chest.



FIG. 3.—Showing the enlargement of the spinali and the atrophy of the rhomboids and lower muscles.

Electrical Treatment.—In chronic and subacute cases electric light or radiant heat treatment should be given daily or on alternate days, and this should be immediately followed by ionization with iodine ions, a 2 per cent. solution of lithium iodide being placed on the lint of the kathode. In cases where much pain is present ionization with salicylic acid ions is of value. Diathermy is of value in relief of pain.

Massage, etc.—When there are no signs of active inflammation and the infective cause has been removed, massage and movements of the joints are indicated. Where the joint movements are much limited in such cases breaking down of adhesions under an anaesthetic or suitable surgical measures may be adopted.

Diet.—In pyrexial cases the diet should be mainly liquid. It must be borne in mind that most cases of non-specific infective arthritis require a diet of high nutritive value, and attention should be directed towards giving a dietary rich in vitamins. Milk, cream, eggs, the unheated juice of fresh lemons or oranges, fresh fruits and vegetables, fish, chicken, and meat, may be given according to the digestive capacity of the patient. If tolerated, milk fermented with lactic acid bacilli is of value in controlling intestinal fermentation. Cod-liver oil and malt, or one of the many substitutes for this now on the market, may also be given with advantage.

In cases of fibrositis of aponeuroses and tendons local electric light and massage gives the best results; diathermy and ionization are sometimes beneficial. In perineuritis, such as sciatica and brachial neuritis, frequent application of electric light gives the best results. Ionization is sometimes of value, and if there is much pain salicylate ions should be used instead of iodine. Iodine may be given internally, and aspirin, phenacetin, or pyramidon for relief of pain. The local application of a mixture of equal parts of chloral, menthol, and camphor on gauze covered by oil silk is very helpful. Complete rest during the acute stage is necessary. In bursitis and teno-synovitis local treatment by electric light and ionization is indicated. In chronic villous synovitis where the above measures fail, the opening of the joint surgically and removal of the villous outgrowths has given good results.

PROGNOSIS.

Where a case of early arthritis is subjected to investigation and treatment on the above lines a complete cure can be effected. In cases of long standing the inflammatory changes are often progressive in nature and removal of the primary cause may do little good because the infective process is being carried on by a secondary intestinal infection. In such cases everything possible should be done to remove both the primary and secondary causes of infection, and when the signs of active inflammation in the joints have ceased measures should be taken to improve the mobility of the joints and muscular tone by massage and movements.

COCCYGEAL FISTULAE.

BY

J. P. LOCKHART-MUMMERY, F.R.C.S.ENG.,
SENIOR SURGEON, ST. MARK'S HOSPITAL FOR DISEASES OF THE
RECTUM.

[With Special Plate.]

THERE is a type of fistula in the anal region which for years was a source of difficulty to surgeons, and still causes much embarrassment unless its nature is recognized. Fistulae of this type cannot be made to heal by the ordinary operative procedure, and failure to make them close is common.

They are always situated over the tip of the coccyx, or very close to it, and behind the anus. There is no internal opening, but frequently there are several external openings. The external openings are small, and discharge a thin serous fluid, or sometimes ordinary pus. The parts around are tender and often inflamed, and the condition causes the patient considerable discomfort when sitting, as the tender area is just at the point where most pressure occurs in the ordinary sitting position. The following case well illustrates the type:

A gentleman, aged 45, as the result, he thought, of a slight blow on the posterior part of the perineum, developed a painful abscess behind the anus. This abscess was opened and scraped

by his medical adviser, but refused to heal. Another operation was then performed and the fistula laid freely open into the rectum, although no actual track could be found opening in this direction. After many weeks lying up and a further unsuccessful operation the fistula was still unhealed, and he was brought to see me. I recognized the nature of the condition and completely excised the fistulous area, after which healing took place without further trouble.

It is quite common to find, as in this case, that several previous operations have been performed without success.

Several years ago the late Mr. Goodall described a number of cases of fistulae over the coccyx, which were difficult to heal, but he did not recognize their nature.

The true nature of these fistulae over the coccyx was recognized by Sir John Bland-Sutton, and his book on *Tumours* contains (fourth edition, p. 436) a description of them. They are congenital—remnants of the faulty coalescence of the cutaneous covering of the back during early embryonic life. They are an exaggeration of the "post-anal dimple" often seen in this situation, and are in reality sequestration dermoids due to skin being shut off from the external surface. The fistulous tracks are lined with skin, and it is for this reason that they will not heal when laid open. In one case, on laying open such a fistula, I found a lock of hair nearly an inch long growing from the walls. It is a curious fact that they may exist for many years without causing any trouble.

The microphotographs accompanying this article show the appearances in cross section of the fistulous track after excision; it can clearly be seen that they are lined with epithelium. Often, of course, considerable modification has occurred in their structure from secondary inflammatory changes, but it will be always possible to demonstrate the presence of epithelial cells in the lining membrane of some part of the fistula. There is often a considerable deposit of fibrous tissue around the fistulae, even when no operation has previously been performed. When, as is usual, one or more operations have been performed, a very complicated condition may be found, but the situation of the external opening near the tip of the coccyx will generally make it possible to surmise the nature of the condition. Often the condition is not noticed until, as the result of some slight injury, a small abscess forms and the parts become painful. Treatment consists in completely cutting out the fistulous tracks. An incision should be made around the external openings and deepened until healthy fat is exposed; then the whole area is cut out down to the coccyx, care being taken to watch for any signs of side tracks, which are often present. The dissection will as a rule go down to the coccyx, and a fairly large wound will result. This is best left to granulate, and will soon fill in with healthy tissue. It is not necessary to excise the coccyx unless a fistulous track is discovered passing up in front of it, when, of course, the track must be followed to its termination.

These congenital coccygeal fistulae are closely related to the dermoid cysts sometimes found behind the rectum, but whereas the fistulae lie superficial to the coccyx, the dermoids are usually on the front or upper surface of the coccyx and between it and the rectum.

These congenital fistulae seldom cause serious trouble, and except as the result of surgical interference never open into the rectum. The chief point of interest about them is that owing to their being lined with skin they will not heal unless completely cut out.

ACUTE OSTEOMYELITIS OF THE LONG BONES IN CHILDREN.

BY

ALEX. MITCHELL, M.A., M.Ch.,
SURGEON AND LECTURER IN CLINICAL SURGERY, ROYAL ABERDEEN
HOSPITAL FOR SICK CHILDREN; ASSISTANT SURGEON,
ROYAL ABERDEEN INFIRMARY.

[With Special Plate.]

ONE cannot work in a children's hospital without being struck by the fact that there is always going on a certain waste of valuable human life, or at least of future efficiency and wage-earning capacity. This occurs in cases in which, through some delay in diagnosis or some unfortunate choice as to a method of treatment, there is lost

the opportunity of saving a life or of putting a child in a fair way to become a useful citizen. The reasons for this are of course the suddenness with which acute disease begins in early life, the rapid course it so often runs, and the great variation of symptoms in any particular disease. These factors make diagnosis difficult for the practitioner, and the surgeon is too often presented with a case in which the indications as to the best possible line of treatment are none too clear. These observations apply, I think, most particularly to acute appendicitis, to empyema of the thorax, and to acute (septic) osteomyelitis of the long bones. In the former two a great advance has been made in the last ten years, but I cannot help thinking that in the last neither as regards immediate recovery nor as to late functional capacity has there been a very great improvement in results as compared with the state of affairs when this was the subject of discussion at a previous meeting of this society (about ten years ago).

Although in a few cases the general infection is so severe, and the local response about the infected bone so slight, that diagnosis is practically impossible, usually there are some local signs which should lead us to suspect what is going on. While I fully appreciate the difficulties of diagnosis, it seems to me, from what I have seen of those cases as they come into hospital, and from a study of their histories, that there are two classes of cases in which undue delay in arriving at a diagnosis occurs:

(1) Cases in which a child has been ill for several days without any apparent cause, and a systematic examination of the ends of the long bones has not been made. This point has been constantly emphasized by Dr. Rose in all his teaching.¹

(2) Cases in which, during an acute illness, an abscess has rapidly formed over the front of the tibia. A small incision has been made, and pus allowed to escape. The true nature of the condition has evidently not been realized, and home treatment continued until one or more of the other bones have been infected. These cases rarely recover.

On the other hand, whatever perfection we may arrive at in rapidity of diagnosis, the fact that the local disturbance may be accompanied or preceded by a severe septicaemia means that the initial mortality must always be fairly high until we can find some more prompt and efficient means of serum therapy than we are at present equipped with.

In cases that recover after operation there is always a great possibility of the functions of affected limbs being permanently impaired. This may be due to:

- (a) Direct extension of infection to periarticular tissues or to the joints themselves.
- (b) Infection of joints through the blood stream.
- (c) Permanent loss of bone substance through destruction of tissues capable of forming new bone.
- (d) Irregular growth, owing to interference with epiphyseal ends.
- (e) Ineffective after-treatment where the whole thickness of the bone has been removed.
- (f) Loss of muscle function from sepsis and from disuse.

The treatment of acute osteomyelitis must vary in some degree according to the type of case which we have to deal with.

While any attempt at classification must be faulty and subject to criticism, I feel, none the less, that if any attempt is to be made to indicate lines of treatment, this must be based on a consideration of the types of case, for in this way only can we hope, on the one hand, to avoid unnecessarily mutilating operations, and on the other, to apply sufficiently radical treatment when it is required. I think we may take it as a generally accepted fact that the process begins at the end of the shaft near to the epiphyseal junction. The only apparent contradiction to this is that one sometimes meets with a fairly acute form commencing high up in the shaft of the femur, but here the focus will be found to be close to an epiphyseal junction—namely, that of the small trochanter.

We may take it also that the so-called "subperiosteal abscess" described in the textbooks is in actual practice very rare, and that an abscess under the periosteum is almost invariably proved to have its origin in an underlying focus of infection in the bone itself.

Keeping these two points in view, and feeling the need of something to justify not advocating the same treatment in every case, I venture to submit the following rough classification into three types, and to discuss the treatment of each.

Type 1.

A case presents signs suggestive of localized mischief at the end of a long bone. The history is a comparatively long one, and the general infection is manifestly not at all severe. Incision reveals the presence of a localized collection of pus under the periosteum, which is separated from the bone only over the abscess area. Here removal of the bone denuded of periosteum will allow for drainage of the medulla, which should not be curetted out, and will—provided that all the denuded bone has been removed and given appropriate after-treatment—usually ensure a good result.

Type 2.

A short history, say twenty-four hours or less, of symptoms of severe general infection with strictly localized but very severe tenderness on pressure at one spot at the end of the shaft. On incision pus is not seen, but the periosteum has begun to separate, or is very easily separated, over the small area where tenderness was made out. When the bone is opened, which it should be freely, a little pus may be detected, but sometimes pus cannot be seen. If cultures be taken from the medulla, a vigorous growth of a staphylococcus, or a streptococcus, will result. In such a case, if treatment has been given at a sufficiently early point in the course of the disease, convalescence will be rapid and the final result good.

Type 3.

The most common type of osteomyelitis seen in hospital practice is that in which there is considerable denudation of periosteum. In some cases the bone will be free of periosteum in almost the whole length of one aspect; in others the stripping seems to have run round the shaft. In the most advanced stage the shaft is completely denuded of periosteum. This variety is only too familiar to us all, and it is the type most commonly met with in which disease of average severity has established itself in the shaft of a long bone.

The usual textbook teaching as to the treatment of those cases may be summed up as follows:

That a good-sized piece of bone should be chiselled out, and that this will amply provide for drainage of infected material, and will give the patient a good chance of recovery. More bone may be removed later if necessary; even the whole shaft may be resected, but if this is to be done it should not be undertaken for some time after, say about two months, in order to give time for new bone to form.

I submit that from the point of view of immediate recovery, and also looking to the possibility of obtaining the best functional result in the future, this treatment has not proved to be satisfactory, and I believe that the correct treatment is to resect (subperiosteally) the whole thickness of the shaft, not necessarily the whole length, but always the whole diameter of the part over which the periosteum does not exhibit a normal degree of attachment to the underlying bone—an operation previously described and strongly advocated to this society by Sir Henry Gray.²

While one has no hesitation in applying it to the humerus and to the femur in suitable cases, fortunately the bone for which this operation is most frequently demanded is the tibia, where, owing to the splinting afforded by the fibula and to the distribution of the muscle attachments, the conditions for operation, after-treatment, and for good end-results are ideal.

The arguments put forward against this apparently too drastic operation are:

(1) That it is not necessary, as if chiselling be freely done it is quite sufficient. This theoretically is true, but the practical difficulty is that it is very difficult to judge when one has chiselled away all the bad bone, and if any is left there is always risk of the infection spreading locally or to other bones. From what I have seen of this operation in the type of case under consideration, the results are not at all good, and a certain number of cases have ended by amputation.

(2) That resection is more difficult and dangerous than chiselling, and that the mortality from it is very high. In the past five years I have resected completely ten tibiae, with two deaths, and six partially, with two deaths. I do not think, when one considers the nature of the disease, that one can look for a much lower mortality than this.

(3) That the bone will not regrow. I do not think that in children one need have any fear of this. I have seen only one case in which growth failed, and one in which it was exceptionally slow. Usually the bone regrows in from three to six months. The bone seems to grow from the epiphyseal ends, and abundantly from the bone-forming cells adherent to the under-surface of the periosteum. A study of skiagrams taken at various stages of regrowth and examination of the limb itself shows this beyond dispute. This is apparently in contradiction to the experiments of Gallie and Robertson,³ but their work as

regards this point is based mainly on animal experiments and on clinical observation made on adults. Great stress has always been laid on the value of inflammation as a stimulant to the activities of the bone-forming cells which get separated up with the periosteum. The finding I am tempted to deduce from my own cases is that while inflammation does, as pointed out by McEwan and others, promote the re-formation of bone in this way, where the sepsis has been very severe, or where pus under the periosteum has been kept too long under tension, the subperiosteal osteogenetic cells get completely destroyed—giving a possible explanation for the occasional case of failure of growth that occurs. Also that if a septic bone shaft be allowed to remain *in situ*, it may sometimes, by keeping up sepsis, act as a deterrent rather than as a stimulant to regrowth of healthy bone, and that therefore, after it has become septic, the quicker it is removed the better. If in any rare case bone growth should fail, one can always get over the difficulty by grafting bone from the other tibia, as I demonstrated by a case shown here recently.

(4) The last argument advanced against resection is that the limb is difficult to manage after, and that the functional results are poor. The after-treatment is certainly difficult, but it can be satisfactorily done, and the results can be judged from the cases shown. On the other hand, when incomplete operation has been done, and sinuses have continued to discharge for long periods, necessitating frequent secondary operations and prolonged hospital treatment, the results as regards the adjacent joints are notoriously bad.

In performing complete removal of the shaft of the tibia the end of the shaft which shows signs of least infection should be divided by a Gigli saw, or by a broad sharp chisel. The bone then can be usually lifted out, as the other end, at which the infection has commenced, is free, or is easily separated from the epiphysis. The periosteal bed is then cleaned up with a little peroxide of hydrogen or euosol, and is packed with gauze strips, which are kept in position by two or three temporary skin sutures. The operation can be performed very speedily. Secondary suture of the periosteum and of the skin is performed in three or four days, and Carrel-Dakin treatment commenced by tubes placed within the periosteum. The Carrel-Dakin tubes can be removed in a few days. The limb is immobilized and extended on a Thomas knee-splint.

Early active movement of the muscles is of the utmost importance in stimulating bone growth, and in helping to form a limb which is straight and free from deformity. The Thomas splint is to be laid aside whenever the shaft of the bone can be felt to have attained to any appreciable degree of firmness. For the lower limb a calliper splint will be used, and walking begun at the earliest possible time. Massage and faradism are of value in keeping up the tone of muscles, but active movement is most useful.

Although these remarks are, strictly speaking, applicable only to osteomyelitis in children, I would like to raise the question as to whether, taking into account the present position of bone transplantation, we might with advantage be less timid in our treatment of adult cases, as I think by so doing we might save more lives and get better results than we have done in the past.

Generally speaking, cultures from the medulla of the bone and a blood culture should be made in every case. An autogenous vaccine may be of value in after-treatment, and it is always of advantage to know if there is an active septicaemia present. Vaccines and serums, though of value as adjuncts to operative treatment, do not seem likely to be able to replace it unless in extremely mild cases.

The value of transfusion of blood from individuals who have been previously vaccinated with the particular organism concerned has been proved to be of value in certain septic cases,⁴ but its use here as a routine treatment in acute cases presents obvious difficulties.

It seems, therefore, that the question of treatment hinges, at present, mainly on the type of operation to be performed, and I hope that by stating my own views, even at the risk of being considered too dogmatic, I may provoke some discussion and derive some help therefrom.

REFERENCES.

¹ *Scottish Medical and Surgical Journal*, 1906. ² *The British Journal of Children's Diseases*, 1909. ³ *The British Journal of Surgery*, 1919. ⁴ H. J. B. Fry, *BRITISH MEDICAL JOURNAL*, February 28th, 1920, p. 209.

A CASE OF IDIOPATHIC MUSCULAR DYSTROPHY.

BY
H. S. CARTER, AND W. FLEMING,
M.B., Ch.B. L.R.C.P., L.R.C. S.Ed.

(From the Ministry of Pension-Hospital, Beckett Park, Leeds.)

[With Special Plate.]

A MAN, aged 24, was admitted to this hospital in January, 1921, his invaliding disability being recorded as synovitis of the left knee.

His history was as follows. He enlisted early during the war, and served for some time at home. As far as he can remember he was perfectly well and of category A 1 until Easter, 1916. About this time he was accidentally kicked on the left knee by a horse. The injured part became swollen and painful, and he was resting at his billet and doing no duty for six weeks. He was not admitted to hospital. In about two months he was better and had very little trouble, except that he noticed his knee give way very occasionally when walking, and rather more often when the limb was under less deliberate control, as in running or in making sudden movements. He was put on fatigue work until he went to France in August, 1917, where he continued in a labour corps. Early in 1918 he fell in the street owing to his left knee giving way, and he dates his downward progress from this.

He was demobilized in February, 1919, and his attributable disability was recorded as synovitis of the left knee joint.

Shortly after returning to civil life he noticed wasting of the left thigh, and had pain in the back and in the left hip region. Tuberculosis of the left hip joint was suspected, but X-ray examination proved negative. Shortly afterwards the right thigh muscles began to waste, and he found that walking became increasingly difficult. Going upstairs became a great task, and he has often been carried up by members of his family. Up to the time of admission to this hospital he had noticed nothing else wrong. Difficulty in walking, with wasting of the thighs and pain in the back, were his complaints. His general health he regarded as good.

Examination.

The patient is a rather thin, pale youth, who walks with the aid of a stick. His gait is clumsy, wide-based, and waddling, with throwing out of the feet, and there is a noticeable lordosis even when he is fully dressed. Stripped he presents a typical picture of muscular dystrophy. The left knee-joint shows no signs of synovitis now and differs in no way from its fellow.

There is much wasting of both thighs. The atrophy, although he has not noticed it himself, has obviously extended to the buttocks and lower part of the trunk. The face, arms, hands, and the legs below the knees appear normal. There is profound wasting of both quadriceps, both sets of adductors, the psoas groups, the abdominal oblique muscles on both sides, and to a lesser extent of the hamstrings, glutei, and latissimus dorsi muscles, the serrati and the rhomboids. Both quadriceps on contraction show two or three ball-shaped relative swellings at intervals in the middles of the muscles. They are not strong enough to extend the legs at the knees. The tensor fasciae femoris on each side is hypertrophied and is used in a compensatory manner in extending the legs and in maintaining an erect posture. In raising the trunk at right angles to the lower limbs the recti abdominis apparently play a principal part, but he is obliged to call in the assistance of his arms. There is some relative hypertrophy, no doubt partly compensatory, of the spinati. He rises from the supine position in the typical "leg climbing" manner. X-ray examination of the hip-joints and spine shows no bony changes. The affected muscles show no fibrillary tremors; their electrical responses are diminished to both faradism and galvanism, but there is no reaction of degeneration and no myasthenic reaction.

The reflexes are normal except where profound atrophy of the muscles concerned prevents their elicitation. There is no dissociation of sensation—tactile, bone, joint, muscle, and temperature senses being unaltered. The other functions of the central nervous system also present no abnormality.

At a meeting on April 13th of the Hospital Conference of New York City, representing forty of the leading hospitals, it was resolved to call the attention of Congress to the injustice that would be caused to charitable institutions by an increase in the tariff on surgical instruments, as proposed in a bill presented to Congress.

Apparently in this case there is as yet no evidence of familial affection. The patient has several brothers, all younger than himself, who are healthy.

Our reason for reporting this case lies in the fact that myopathy starting in the thigh muscles and described as the type of Leyden, Moebius, and Zimmerlin is of some rarity.

We have to thank Dr. C. E. Ligertwood, medical superintendent of this hospital, for permission to record the case.

ARTIFICIAL PNEUMOTHORAX.*

BY

CLIVE RIVIERE, M.D., F.R.C.P.,

PHYSICIAN, CITY OF LONDON HOSPITAL FOR DISEASES OF THE CHEST,
AND EAST LONDON HOSPITAL FOR CHILDREN.

It is now some thirty years since artificial pneumothorax came into practical use in the treatment of pulmonary tuberculosis. During this period the roll of its adherents has steadily increased as its value has become more and more widely recognized, and the opposition which new methods always have to encounter, and which in this case has never been very strenuous, appears to have died down or disappeared. At the present time the treatment is practised in most of our sanatoriums, and in London the County Council have arranged to supply it to patients of the hospital class. As to the opposition it has encountered, such opposition as I have observed has shown itself rather in a studied neglect of the method than in open antagonism. Among those who have really investigated and practised the treatment I have neither met nor read of opposing opinions as to its value. This unanimity among the initiated has seemed to me nothing less than remarkable; for it is a treatment that involves no small amount of art and judgement, as well as some knowledge, and the success achieved might well be expected to differ, and differ widely, in the hands of various operators. If there have been any persistently "unlucky" centres, their fame has never reached my ears; and in this connexion it is important that the class of case treated be taken into careful consideration before any judgement is passed on results.

Those who reserve the treatment for advanced and otherwise hopeless patients may well find ill-fame in spite of the utmost skill: on the other hand, those who treat early cases by pneumothorax will achieve a success which they in no way deserve. The peculiarly individual character of each pneumothorax case, both as to the nature and amount of disease, and the varying features of the "gas pad" applied, defeats all efforts to classify the results; those who wish to convince themselves must do so on individual cases. The return to health of a single case of advanced unilateral disease under pneumothorax treatment will have an effect on their minds which statistics will neither increase nor diminish. I shall not, therefore, waste time now over the results, feeling that I shall open this discussion more usefully by inviting your remarks and criticisms over a wider field. If we achieve the best possible in the selection of cases and in the art of their treatment, we may safely leave the results to win a steady recognition for themselves.

Indications for Treatment.

First, as to indications for pneumothorax treatment—for the first essential to success lies in the proper selection of cases—these must miss on the one hand those who can recover by other means, and, on the other hand, those for whom a pneumothorax will merely mean acceleration of their inevitable end. Forlanini's dictum can, perhaps, hardly be improved upon. "Pneumothorax," he remarked, "is indicated every time that life is threatened by the extension of a local lesion." This is not to say, of course, that all such cases are suitable, since contraindications may exist, but in all such cases the question of a pneumothorax demands investigation. In practice it is surprising how many cases with disease of the whole of one lung turn up for this treatment. This is not, I am convinced, as a rule due to the negligence of physicians who have allowed disease to spread from apex to base before they awoke to the need of doing something. But disease in these cases

is of hilus origin, has progressed in the deep parts of the lung, and on reaching the surface is soon evident to auscultation over the whole of one side. In such patients the *x* rays will often discover advanced disease of the opposite lung also, though to the stethoscope it may appear quite sound because the process has not yet reached the surface. For this reason it is imperative, where at all possible, that a radiogram be taken before a pneumothorax is embarked on, for above all other considerations the condition of the other lung is the point of the most moment. How much disease may be permitted in the other lung without its forming a contraindication to pneumothorax is a matter which cannot be described on paper, and is often very difficult to decide upon in practice. In my experience the question of activity is of far greater importance in this decision than extent or locality of disease. Rarely is the other lung altogether free of disease unless in pneumonic cases, and in these, nevertheless, the prognosis is bad. But torpid lesions, even of wide extent, may be expected to clear up or improve—the strain of increased function seems to be more than counter-balanced in these cases by the removal of focal reactions and toxæmia, and the effects of the hyperæmia which is probably brought about. Active lesions, on the other hand, tend to spread and get worse. But even to this there may perhaps be exceptions. Many writers, notably to my recollection Mary Lapham, and Parfitt and Crombie, have recorded improvement and recovery under pneumothorax in cases where the other lung was so bad as to appear to be a contraindication. In some of these the *x* rays were not used till after the pneumothorax was initiated, and the writers are therefore inclined rather to discount the *x*-ray findings in deciding on the suitability of a case. Nevertheless the *x* ray must be our standby, and if we are to extend our field of treatment to cases of more doubtful suitability it can only be through increased experience of the radiological appearances.

Conducted Rales.

One of the warnings I should like to make while speaking on selection of cases is against mistaking conducted sounds for evidence of disease in the better lung. Sharp consonating crepitations are nearly always audible on the opposite side near the spine, and not infrequently about the axilla, though, curiously enough, they may be less plainly heard in some cases in the area between these points. Often a pneumothorax will unexpectedly remove sounds in the functioning lung, and frequently, I am sure, these sounds have been merely conducted. Crepitations at the base or round the heart on the good side are not always, I think, a contraindication to pneumothorax, where the *x* rays show only quiet peribronchial disease. Such signs may clear as treatment progresses. In cases where the better lung is of doubtful reliability a waiting period of complete rest may improve matters; but in other cases the chance of doing a pneumothorax may, through waiting, pass by and be lost.

Intervals and Quantity of Gas.

To pass over the initial operation, regarding which I have nothing new to remark, and to come straight to the pneumothorax already induced, I should like to refer to the intervals between refills, and to the quantity of gas it is wise to introduce. I find a tendency in this country to give larger fillings, and hence at longer intervals, than are advised by the most experienced Continental authorities. For example, Forlanini in Italy recommended only 200 to 300 c.c.m., rising at most to 500 c.c.m. at each filling; Dunarest in France rarely leaves longer than three weeks between refills, unless in cases of thickened pleura; Brauer and Spengler, in Germany and Switzerland respectively, advise 400 to 800 c.c.m. In this country fillings of 1,000 c.c.m. or more seem to be approved of, and one authority teaches, I am informed, that the intervals achieved should be one month in the first year, two months in the second year, and three months in the third year of treatment. This has led, in one case I believe at least, to the need for two refills on consecutive days before the pneumothorax could be re-established at its former volume and pressure. Such a release of collapse seems to me very undesirable, and is condemned on grounds of *post-mortem* experience by some of the best authorities.

Personally, I have found that it is not possible to fix any standard interval between refills, but each case must be a

* Opening paper in a discussion at the Royal Society of Medicine on May 24th, 1921.

law unto itself. For it may happen in one case that a weak mediastinum prevents our achieving complete collapse of the lung, with the result that gas absorption is rapid, and the intervals have to be short—as in a case of mine who can at most achieve a two and a half weeks' interval in the fourth year of treatment; or, on the other hand, pleurisy may early limit absorption and permit of long intervals even near the outset of treatment—as in another patient, whose pneumothorax was started last July, and who has received but 1,120 c.cm. of gas, in two refills, since November last. In my experience it is not wise to let refills run above 700 or 800 c.cm., and in most cases 500 c.cm., or even less, is a preferable amount. The selected quantity will, of course, determine the interval, and this will be long or short according to the rate of absorption. But, quantity of gas apart, a long interval may allow of expansion and attachment of an imperfectly collapsed lung, as happened in the case of weak mediastinum quoted above. This patient was persuaded on one occasion to lengthen his interval to one month, with the result that the lung became adherent to the chest wall in two places. The doctor who made this recommendation was unaware that the lung, though out of reach of the stethoscope, was but imperfectly collapsed at such pressure as could be used,—a fact which was only revealed to x-ray examination.

Pleural Sclerosis.

There is no doubt that the x rays are a well-nigh indispensable adjunct to treatment, alike in the fixing of the optimum pressure at the outset, and also in the readjustment of this at intervals during the course of treatment. In process of time, even apart from the occurrence of definite pleurisy, the pleural layers undergo a chronic inflammatory thickening, followed by contraction, and the mechanical conditions in the chest are thereby altered. Where the heart has been pushed far over to the opposite side it may be seen to return towards the pneumothorax, and therewith the lung may show a tendency towards re-expansion. Under these conditions the interpleural pressure must be steadily raised or the heart and lung will become attached to the chest wall and treatment be interfered with. This readjustment of pressure is a point which must be constantly in mind as treatment progresses. In some cases of pleural thickening, and particularly after purulent pleurisy, no amount of pressure will prevent gradual closing up of the cavity and re-expansion of the lung. In such patients, nevertheless, the expected disaster does not always materialize, for the pleural fibrosis may spread through the lung itself, and healing be thus brought about.

Weak Mediastinum.

Another side to the problem of intrapleural pressures is that concerned with weak mediastinum and with ballooning of the pleura. Mediastinal over-displacement may be difficult to discover without x-ray examination, for the manometric signs described by certain writers (slow rise of pressure, with stationary points, and small fluctuations) are not, I think, of much value. The symptoms may be vague, and the position of the heart may not appear to be unduly altered. As a matter of fact, the same amount of displacement may be borne without discomfort in one patient but cause marked symptoms in another. The symptoms may amount to vague discomfort, with ill-defined distress and inability to sleep, or pseudo-asthmatic symptoms may appear, with dyspnoea, an audible wheeze, and attacks which may be of a very alarming character. All these symptoms disappear as soon as their cause is recognized, the pressure lowered, and the mediastinum allowed to recover its tone. In these cases, and in some others where the displacement is less striking, crepitations may appear at the opposite base and may continue for months or years. They are an indication for a lowering of pressure, but such lowering may be impossible without allowing the lung to expand. Where the signs have, from necessity, been allowed to remain I have not seen any harm result from their presence. They represent presumably an oedema of the lung base in most cases, but in some the dryness of the sound, and its appearance or increase immediately after a filling, suggests mere atelectasis as the explanation. In two of my cases, also, I have experienced a definite lung oedema with frothy sputum during the early stages of treatment, owing to circulatory embarrassment in the better lung.

Inflamed Pleura and its Treatment.

A condition which seems to tempt operators to a raising of pressure—always, I am sure, to the patient's harm—is the onset of pleurisy. This is illustrated by a chart, among many I have seen, which came under my notice a few days ago. At the sixth injection the pressure was raised for the first time to the modest figure of $-3 + 2$; four days later fluid was found, and the pressure was $+1 + 8$, and yet 40 c.cm. were put in and the pressure raised to $+3 + 9$; at a later stage in the same case a return of fluid is noted, and the same increase of pressure was instituted, though it had been kept low in the interval. I do not regard this as a rational procedure, but agree with Continental observers that we should hold our hand, and even avoid puncture altogether, during the earlier stages of pleurisy, since such interference may aggravate the inflammation. Moreover, it may lead, as I have seen in these cases, to troublesome displacement of the mediastinum. There is, fortunately, no need for puncture during the early stages of pleurisy, since gas absorption almost ceases, but it is, I fancy, the small amount of gas which can be put in that tempts those who do puncture to raise the pressure. The loss of resilience due to inflammatory congestion must not be confused with the stiffness of chronic thickening, in which condition, of course, high pressures can and should be employed.

"Ballooning" of the pleura towards the healthy side at certain weak spots, and particularly in front under the sternum between the first and fourth rib articulations, is an occurrence which is quite common, but has not attracted a large amount of attention. It reveals itself by giving the physical signs of a gas pocket, and is generally visible to x rays as an elliptical encroachment on the healthy side with a visible sharp border. I have so far seen no harmful results accompany this occurrence.

Surgical Treatment of Adhesions.

A subject of the greatest moment, in that it promises to open a doorway from pneumothorax treatment into wider fields, is the surgical treatment of adhesions, and especially of adherent pleura. Localized adhesions, if solitary or few, can be divided without opening the chest by the galvano-cautery or with a tenotome. Jacobaeus's method consists in the introduction of an instrument called the thoracoscope, with which the adhesions are visualized, and thereafter in the introduction of a cannula in the neighbourhood of the adhesion, and its severance by a galvano-cautery introduced through the cannula. The technique is difficult, but a good deal of success has attended its use in skilful hands, as may be gathered by an article by the Norwegian Holmboe in the October, 1919, number of *Tubercle*. Division of adhesions with a tenotome has been practised by Morrison Davies in this country, the operation being carried out under the x rays.

For cases where a few strong adhesions are preventing treatment one or other of these methods may succeed; with multiple adhesions I am inclined to think opening the chest may prove a more satisfactory procedure.

About a year ago, in a private patient for whom I produced a pneumothorax, the lung failed to collapse adequately owing to the presence of numerous firm adhesions to the chest wall. Persistent low pressures did not lead to their stretching or separation, and higher pressures were barred on account of the presence of large and numerous cavities which I feared I might be torn open. Recently the condition was becoming less and less satisfactory owing to the further shortening of the adhesions as the result of chronic pleural inflammation and fibrosis. Some three weeks back Mr. Romanus at my request opened the chest wall through the third space and divided, with scissors and galvano-cautery, seven strong adhesions, mostly rounded bands, but one with a fairly wide attachment. This allowed the lung to collapse, which it did to a moderate degree only, being soon with disease. The actual operation took twenty-three minutes, was done under gas and oxygen only, and no rib resection was contemplated or performed, an ample opening being obtained between the spaces with special retractors. The operation led to very little reaction or other disturbance, except for the expected temporary increase of sputum. A refill was given on the seventh day and again on the twelfth, and all seems well save for doubts as to the ultimate behaviour of the functioning lung.

Separation of Adherent Lung.

Of recent years the separation of lung adherent over a larger surface to the chest wall has been attempted on various occasions. In 1918 Professor Schtümmler, of Hauburg-Eppendorf, described how he advised the trial

of this for a case in which Jessen had found the pleural surfaces adherent. Jessen refused to attempt it, but Sudeck removed most of the fourth rib and separated many adhesions by hand, and a good result was recorded. Eden of Jena, stimulated by this, operated on a case, but found the surfaces very difficult to separate, and had to confess that the pneumothorax obtained was only partly intrapleural. Some days later the patient ruptured a lung cavity during the act of coughing. Ulrici also treated a case by this means, but the operation lasted one and a half hours, and the patient succumbed eventually to extension of disease in the opposite lung and other organs. I cannot feel that the separation of adherent pleura, apart from well-defined bands, by surgical means, is at all a sensible proposition, and fortunately there appear to be other possibilities.

Stripping the Costal Pleura: Tuffier's Operation.—Just a year ago I got Mr. Romanis to strip the parietal pleura from the endothoracic fascia over the apex (apicolysis) in a private patient who suffered with a bleeding cavity, and to pack the resulting space with solid paraffin. I was so much impressed on this occasion with the ease with which the parietal pleura stripped, and with the comparative mildness of the operation, done under gas and oxygen and without rib resection, that I felt encouraged to try it in other cases where adherent pleura prevented the production of pneumothorax. Not long after this I came upon a paper by Rieckenburg, working under Ulrici at Sommerfeld, in which he describes two cases of adherent lung where the costal pleura was stripped from the chest wall, and a pneumothorax maintained outside it. He points out the value of the double covering over large cavities in diminishing the danger of perforation, and notes that the raw pleural surface in healing contracts down and prevents further expansion of the lung. The cavity holds gas only under low pressures at first, but eventually it becomes effectively "gas-tight." Encouraged by the possibility this offered, I asked Mr. Romanis in January last to strip the whole costal pleura in a case eminently suitable for pneumothorax, but with total adhesion of the pleural surfaces. The patient had chronic disease of the whole right lung with cavitation, and ran fever to 100.5° in spite of prolonged rest. The left lung was an excellent organ. The chest was opened through the third space, and the pleura separated with the hand over all but the inner surface of the lung. Ample room for insertion of the hand between the ribs was obtained by strong retraction, and the pleura stripped with the greatest ease, but the lung collapsed little as it was solid with disease. The operation lasted but twenty minutes, and was followed by very little shock or reaction. It was realized that the absorption of air would be rapid, but I thought a week could be left before the refill. Most unfortunately, however, the patient only came into my hands again after an interval of twelve days, and by then all the air was found absorbed and the lung re-expanded. It would be wiser, I think, in such a case to leave a small opening to the outer air, and to close this at the end of a week, when refills can be conveniently substituted. The sequel in this case was interesting, for the temporary immobilization of the lung allowed the patient to re-establish tolerance, and the temperature fell to 99° and has remained there; at the same time both lung and general condition have improved. This improvement is reminiscent of some experiences of Schroeder, who found lung fibrosis and recovery to follow a severe traumatic pleurisy in three cases where he attempted, without success, to separate adherent pleural surfaces after a pneumothorax operation by Brauer's open method.

Extrapleural Thoracoplasty.

I have referred to the possibility of thus creating and maintaining an extrapleural pneumothorax because the idea may be new to some of those here present. Of the better recognized means of dealing with adherent pleura, by extrapleural thoracoplasty under local anaesthesia, I shall not here speak, but I hope some others now present may do so. Two admirable papers on this subject by Scandinavian authorities appeared in our journals last year, one in *Tubercle* of April, 1920, by Saugman, dealing with 41 cases, and one by Bull of Christiania in the *Lancet* of October 16th, 1920, with an account of 37 cases. The results appeared to be excellent, and the actual operation mortality small, amounting to but 4 cases in each series.

With regard to all these surgical procedures, it must be noted that operations are not to be lightly undertaken in the subjects of pulmonary tuberculosis; the cases require even more careful selection, especially as regards the condition of the better lung, than they do for mere pneumothorax treatment. Before leaving the subject of adherent pleura I should like to insist that no operative measures must be undertaken for its relief until its actuality is determined by experiment. It might well be supposed that where a great displacement of organs and closing in of ribs has occurred, we are then necessarily dealing with

adherent pleura. But this is by no means the case, as I can illustrate by a radiogram from a patient on whom I induced a pneumothorax some three weeks ago. The heart was entirely in the right chest, and the trachea was drawn over and distorted; and yet the pleural surfaces proved un-adherent, with the result, as would be expected, that the intrapleural pressure had fallen to a very low figure—actually to $-27 - 25$ cm. of water.

Pneumothorax treatment is a big subject, because it involves so many possibilities. What I should like finally to insist on here is the comparative narrowness of its indications, but its striking hopefulness within these limits. All is possible to a case of unilateral, or practically unilateral disease, if only we are sufficiently persistent. It is for that reason that I have wandered to-day into the byways of surgical interference, feeling that in these cases adherent pleura is no excuse for folding our hands and giving in. The patient with one lung has a good fighting chance if only our skill and resourcefulness suffice to discover for him the road to victory.

Memoranda:

MEDICAL, SURGICAL, OBSTETRICAL.

THE DESTRUCTION OF BACILLI BY ELECTRICITY.

In 1915 I started some experiments for the destruction of bacteria by electricity. Pus from a streptococcal abscess was collected in a sterile copper vessel; cultivations on agar yielded a virulent streptococcus. After passing a continuous electric current of 100 milliampères through the pus for an hour no growth was obtained on agar, but at the bottom of the copper vessel I found a deposit of copper salts sufficient to kill the most virulent streptococcus.

I next tried an electric bath with a carbon pole. I had a patient with a very bad septic forearm, which did not improve with free drainage and antiseptic treatment. I obtained a large porcelain arm bath, filled it with 10 per cent. saline solution, and put one carbon pole at one end of the bath; I made the patient's septic arm the other pole by attaching a zinc plate to his shoulder and allowing him to rest the limb in the warm saline solution. I now passed 80 milliampères continuous current through the bath and left the arm in it for half an hour. The following day the arm looked very much cleaner and the granulations much healthier. Each day it improved, and within about ten days with daily baths it was almost healed. I discussed the treatment with my colleagues, and we agreed that in all probability the improvement was due to free chlorine gas, which was being liberated by the electric current passing through the saline solution. I was, however, struck by the rapid growth of healthy granulation tissue, which I was convinced was stimulated by the current.

From 1917 to 1919 I continued my observations at the Norfolk and Norwich Hospital, and there treated a number of gunshot wounds with septic sinuses by means of copper sulphate ionization. The sinus was cleaned out and filled with a 1 per cent. solution of copper sulphate. A copper rod was then put down the sinus and a zinc pad placed on the patient's back. The two poles were connected respectively to the anode and cathode of a galvanic battery and a constant current of about 8 milliampères passed through for about fifteen minutes daily. The rapid healing of the wound was marked by the rapid growth of granulation tissue.

In an attempt to prove that the electric current actually played a part in the destruction of organisms I constructed an apparatus by which the current passed through some pus, but the poles were not in it. By this means the gas given off at the pole could not play a part in the destruction. I obtained a glass vessel, divided into three compartments by plates which would conduct the current. I placed some pus laden with *Staphylococcus aureus* in the middle compartment and the positive pole into one and the negative pole into the other of the two remaining compartments, which were filled with normal saline. A current of 50 milliampères was then passed through for half an hour at 70° F. By incubation on agar for eighteen hours a very small growth of *Staphylococcus aureus* was obtained. The current was allowed to continue running

through the pus for another hour, at the end of which time a further culture was taken and after forty-eight hours' incubation no growth could be seen on agar.

In 1915 I introduced into the out-patient department of this hospital electric baths for sepsis, and they have been used daily ever since with success.

Recently I have tried the same experiment with pus containing *B. coli*, and found it took a current of 80 milliamperes for one hour to kill the organisms. Based on the results of my recent investigations I am convinced that in introducing electric baths to combat sepsis I was not only introducing a means of stimulating granulation tissue and of cleaning the wound but an actual means of destroying the organisms infecting it.

For valuable help in examining the cultures and for advice on many points I am indebted to Dr. H. M. Galt, pathologist to this hospital.

P. C. COLLINGWOOD FENWICK,
Senior Resident Surgical Officer, Royal Sussex
County Hospital.

ENTERO-COLIC INTUSSUSCEPTION IN AN ADULT.

W. B., a pale, thin man aged 46, who for the previous four months had been subject to occasional abdominal discomfort but who had otherwise always enjoyed good health, was suddenly seized with severe abdominal pain at 7 a.m. on February 16th, 1920. The pain was intermittent, of increasing severity, and accompanied by retching and occasional vomiting. Shortly after the onset of symptoms the bowels were twice moved and flatus passed.

When first seen, at noon, a rounded, prominent swelling, almost as large as a coconut, was visible in the right iliac region; it was dull on percussion and tender on palpation. The area of greatest tenderness as also of pain, however, was below the right costal margin and in the epigastrium.

His wife volunteered the statement that during a paroxysm of pain, whilst pressing on his abdomen to ease him, she heard a "click," and immediately afterwards discovered the swelling. He was sent to the Victoria Cottage Hospital, Woking. When admitted half an hour later he was collapsed; the temperature was 96.4° and the pulse 64.

Operation.

At 2 p.m. the abdomen was opened through the right rectus sheath; enormously distended and congested large bowel exposed; tracing this in both directions it was found that the ascending colon, as far as the hepatic flexure, the caecum, and about 6 in. of ileum were distended by intussuscepted small bowel. At the apex of the intussusception an oval mass about 2 in. long could be felt, suggestive of a polypus. The intussusception being irreducible, and total excision, owing to the patient's condition, holding out little prospect of success, the ileum above the intussusception was laterally anastomosed to the transverse colon and the abdomen closed. He had only slight post-anaesthetic vomiting.

After-History.

Next morning he complained of a good deal of abdominal pain, nausea, and frequent hiccough, and became faint when moved. The temperature was 100.2° and the pulse 110.

On February 18th the temperature was 99.6° and the pulse 76; there was some increasing abdominal distension. A turpentine enema was followed by severe collapse; the motion consisted of altered blood. On the next day the bowels had moved several times in response to repeated doses of magnesium sulphate and the general condition was improved. The temperature was 100.4° and the pulse 84. From this time onwards the patient's condition steadily improved; pain, nausea, and hiccough gradually subsided; the bowels were moved daily; the appetite returned and the pulse improved, but the temperature remained constantly between 99° and 100°. On February 26th he complained of severe griping pains, and the following morning had desire to go to stool and passed the entire intussusception. The temperature fell to normal five days later and he made an uninterrupted recovery. He was discharged from the hospital on March 23rd and has remained in excellent health since.

Owing to advanced decomposition it was not possible to make a satisfactory examination of the intussusception. It was about 18 in. in length, the lower end (apex) apparently terminating blindly and containing thick (? faecal) material. No tumour was detected.

The appearance of the specimen and the distance of the starting-point from the caecum suggest that a Meckel's

diverticulum may possibly have been the cause of the intussusception. That it was entirely irreducible seven hours after onset was, no doubt, due to the large amount of mesentery contained. The comparatively slight constitutional disturbance after the first few days is noteworthy.

I am indebted to Dr. F. M. Haig, who administered the anaesthetic, and to Dr. F. E. A. Colby, who assisted me in the operation.

Woking.

B. H. KINGSFORD, M.D. Lond.

British Medical Association.

CLINICAL AND SCIENTIFIC PROCEEDINGS.

LEEDS DIVISION.

A SUCCESSFUL meeting of the Leeds Division was held in the Leeds Township Infirmary on May 19th. In addition to the ordinary business, papers were read and cases and specimens were shown.

Graphic Methods in Cardiac Diagnosis.

Dr. T. WARDROP GRIFFITH gave a lantern demonstration to show the use of the graphic methods of studying affections of the heart. At the outset he emphasized the view that all the more recent methods, such as the use of the polygraph and of the electro-cardiograph, should be regarded as supplementary to and not as superseding the ordinary methods of examination. The more he used these instruments the more he found he was able to dispense with their use. It was, however, owing to the researches of a large body of workers, using these instruments, that the knowledge of cardiac disease and of cardiac affections had advanced. There were many men who with great facility made an accurate diagnosis of fibrillation of the auricle on the recognition of a non-rhythmical action of the heart, and who forgot, or seemed to forget, that their ability to do so depended entirely upon the work of Sir James Mackenzie, Dr. Thomas Lewis, and those who, like Professor Cushman, had paved the way by experiments on animals.

In the course of his demonstration Dr. Griffith dealt with those temporary interferences with auriculo-ventricular conductivity which sometimes occurred in pneumonia, and gave an account of one case in which some impairment of conductivity was accentuated by the use of digitalis, a drug which, however, had probably saved the life of the patient. Another instance was given of a lad with impaired conductivity, in whose case the impairment was abolished by the use of atropine, only to return in a few hours, but in which conductivity was found to be normal at the end of two years. Examples of different degrees of block leading up to complete disassociation were shown.

Leucocytic Changes in Hodgkin's Disease.

Professor STEWART read a paper on the leucocytic changes in Hodgkin's disease and their diagnostic significance. He said that the leucocytic count in Hodgkin's disease was very variable, not only in different cases, but in the same case at different times. Deviations from the normal were most marked in acute and subacute cases. There were three chief types of leucocytic changes—in order of frequency: (1) a neutrophil leucocytosis, relative and absolute; (2) a relative and absolute increase of the large mononuclear cells, not lymphocytes, especially of the transitional type; (3) a relative and absolute eosinophilia. Any one of these three, if well marked, was of some value in the differential diagnosis of a suspected case of Hodgkin's disease, but No. 2, a large mononucleosis, mainly of transitional type, was the only one on which much reliance could be placed. In 8 recent cases in which the diagnosis of Hodgkin's disease was established by histological examination of an excised gland or glands, 3 showed this large mononucleosis, varying from 19 to 33 per cent. (absolute figures, 1,430 to 3,370 per cubic millimetre). The normal figures for large mononuclears (including transitionals) might be taken as from 4 to 10 per cent., or about 240 to 900 per cubic millimetre in absolute figures. Two other cases showed a high neutrophil leucocytosis (20,000, with 95 per cent. polymorphs; and 33,000, with 89 per cent. polymorphs). In a third case there was a terminal relative neutrophilia (9,000 leucocytes, with 96 per cent.

polymorphs). In none of the 8 cases was there a blood eosinophilia, even when the glands were overrun by these cells, as was the case in several. Other observers (Peyzer, Topycope, etc.) had recorded cases in which a general eosinophilia was present. An absolute lymphocytosis was quite exceptional, although there might be a relative excess of these cells when, as not infrequently happened, a leucopenia existed. While the examinations of the blood might therefore, in certain cases, aid in the diagnosis of Hodgkin's disease, the excision and microscopic examination of a gland still remained the only thoroughly reliable method of establishing the diagnosis.

Post-Operative X Rays in Breast Cancer.

Dr. ROWDEN read a paper on the post-operative x-ray prophylactic treatment of malignant disease of the breast. He said that the operation for malignant disease of the breast was generally disappointing, owing to the large percentage of recurrences locally, and mostly within twelve months: with post-operative x-ray treatment local recurrence was unusual; without x-ray treatment death was not usual without local recurrence. Dr. Rowden expressed the opinion that x-ray treatment of malignant breast without operation was quite unjustifiable, nor was x-ray treatment immediately before operation justifiable. Radiation had a marked paralytic effect on growing and young cells, but the rays were rapidly filtered out in passing through tissues, and therefore could not affect a growing cell deeply placed without injuring the overlying tissues. After operation the condition was more favourable for the use of x-rays as the cancer cells are near the surface. A short and active treatment was advisable. Dr. Rowden suggested to the surgeon: (1) Early operation; (2) to leave no raw surface—a raw surface appearing to favour local recurrence; (3) to order the rays two weeks after the operation, six to eight weeks after operation was too late. Dr. Rowden gave the following statistics of 21 cases with completed treatment up to three years ago since 1909. Of these cases there has been only one local recurrence five years after operation.

15 are living; all well except the case of recurrence.

5 have died:

One 9 years after operation—disease in mediastinum;

One 16 months after operation—disease in spine;

One 17 months after operation—disease in mediastinum;

One 2½ years after operation—mediastinum and neck;

One 2½ years after operation—mediastinum and neck.

1 cannot be traced.

Dr. ALLAN showed pathological and surgical specimens, also some surgical cases.

Reports of Societies.

ARTIFICIAL PNEUMOTHORAX.

At the meeting of the Section of Medicine of the Royal Society of Medicine, on May 24th, Dr. A. F. VOELCKER presiding, Dr. CLIVE RIVIERE read a paper on artificial pneumothorax, which is printed in full at page 810.

In the course of the discussion following the paper Sir JAMES KINGSTON FOWLER described the first case in his experience in which artificial pneumothorax was performed for the relief of haemoptysis. This was in 1885, when a patient was admitted to Middlesex Hospital, and within thirty-one days had twenty-one severe attacks of haemoptysis, and brought up 196 ounces of blood. It was then decided to make an incision in the thorax and induce, if possible, collapse of the lung by this method. The operation was performed, and the lower lobe collapsed to some extent. There were two attacks of haemoptysis subsequently during the five days for which the patient lived, and about 10 ounces of blood were brought up. It was found that there were adhesions which prevented complete collapse. It was quite impossible to have saved the man's life; but, despite the imperfect methods then employed, he thought it might be claimed that even at that time there was a measure of success. In the first place, there was very little haemorrhage after the operation compared with the great amount that had taken place

before, and the lung underwent a certain degree of collapse, which would have been complete had it not been for adhesions. He considered that the introduction of artificial pneumothorax was one of the great advances in treatment within his long experience.

Dr. VERE PEARSON thought that there was still too much diffidence in advising or undertaking this operation. Experience had taught him that it was quite impossible to tell beforehand with the help of x-rays or any method of examination whether adhesions were present which were going to prevent pneumothorax. He now abandoned the procedure if he failed after two sittings at each of which he punctured perhaps three times. He had also given up attempting, in cases with a good many adhesions, to break these down in the early stages by increasing the pressure; such cases failed to do well. It was in one such case that he came across an indication of gas embolism. The other bugbear was pleural reflex; he had had two cases with very alarming symptoms, which he put down to that condition. He found that the liability to the outpouring of fluid did not vary materially whether the pneumothorax was complete or partial. In conclusion, he felt that there was a hiatus between the surgeon and the physician which ought to be bridged.

Dr. NEVILLE COX, speaking from his experience at Midhurst, also appealed for more help from competent surgeons, and said that every large sanatorium should have a properly equipped operating theatre with a surgeon prepared to deal with these cases. He instanced also two points of technique—the first, that the use of a pointed needle for the first injection should be avoided, for it must be a matter of luck rather than skill if there was not a puncture of the lung; the second, the inadvisability of using tuberculin in after-treatment.

Dr. DONALD HALL was convinced of the great value of the treatment. There must be in this country hundreds of cases left to die because it was denied. The treatment did not receive from the profession as a whole the recognition which was its due. For this neglect there might be several reasons or excuses, among them ignorance, lack of material, timidity, and the strain which the treatment imposed on patient and physician. Cases must be selected with the greatest care, but he thought that for pulmonary tuberculosis with excavation artificial pneumothorax at present held the field.

Dr. JANE WALKER said that at the East Anglian Sanatorium this treatment had been applied in 117 cases, and there had been failure to produce pneumothorax in about 10 per cent. A certain amount of mischief in the other lung was not a contraindication, and in a large number of cases, with the general improvement in the patient's condition, a diminution of the signs in the other lung had taken place. So far there had been no serious accident, except that occasionally a vein had been punctured. The simplest possible form of apparatus was used, and the only modification which had been made since this treatment was first practised was that air instead of nitrogen was used. She thought that the time had now come to consider whether this method of treatment should not be applied to cases before they became so severely ill. In all these cases the artificial pneumothorax was induced as the last hope, and although the percentage of recoveries was comparatively low, life had been made more bearable for many.

Dr. C. S. BURRELL thought that the spacing of the refills was of the greatest importance. Unless they took each case individually and refilled at intervals which were found suitable in each instance, they were not likely to be successful. He agreed with the method of giving a small quantity of air at frequent intervals, the maximum interval being a month.

CAUSES, PROGNOSIS, AND TREATMENT OF STERILITY.

At the meeting of the Section of Obstetrics and Gynaecology of the Royal Society of Medicine held on May 5th, with Professor HENRY BRIGGS, the President, in the chair, Dr. ARTHUR GILES opened a discussion on the causes, prognosis, and treatment of sterility. He said that he proposed to touch on two of the general aspects of the subject—the prevalence of sterility, and the responsibility of the male partner—and then to sketch out three types of sterility in women, viewed from the standpoint of pro-

gnosis and treatment—namely, (a) inevitable and incurable sterility, (b) functional sterility, and (c) conditions that caused or favoured sterility, but allowed of treatment. Estimates of the proportion of infertile marriages varied widely with different authors and in different countries. Some, like Frank and Burdach, placed it as low as 2 per cent.; others as high as 20 per cent. He had endeavoured to form an estimate from his case papers, with the result that he thought it was a sound deduction that the proportion of sterile marriages in this country was well below 15 per cent. Dependence upon figures given by various writers was weakened by the fact that in some statistics stillbirths were taken into account while in others they were not. Of published estimates he was disposed to regard those of Simpson as being nearest to the truth; he found the proportion of unfruitful marriages to be 10.9 per cent. in village communities, and 16.3 per cent. in families of the aristocracy. The ratio was probably higher in towns than in the country.

It was not sufficiently realized that in many cases the woman was not at fault. Estimates again varied widely as to the proportion of cases in which the husband was to blame. The actual figures were of less consequence than appreciation of the fact that in a childless marriage the woman might not be at fault, because it had an important practical corollary that in doubtful cases the wife should not be assumed to be responsible and submitted to operative procedures without obtaining definite evidence that the husband was healthy. It would be all the easier to recognize the cases of incurable sterility if the conditions necessary for successful impregnation were remembered. They were: On the man's part, ability to deposit healthy seminal fluid in contact with the os externum cervicis; on the woman's part, (1) ability to receive this fluid in contact with the cervix; (2) such a healthy condition of uterus, tubes and ovaries as would enable the spermatozoa to travel up to meet the ovum; (3) the production and discharge of healthy ova; (4) such a healthy condition of the uterus as would enable it to harbour the fertilized ovum.

1. The conditions under this head that caused sterility were absence of the vagina and want of communication between the vagina and the uterus. It might be necessary to undertake a dissection of the parts before the point could be cleared up. When the vagina was absent the question might arise whether an artificial one should be made. From the point of view of sterility the procedure would be hopeless. Whether it should be done in order to make married life possible was another matter.

2. This condition was unfulfilled in the case of absence or marked under-development of the uterus, congenital atresia of the tubes, and occlusion of the tubal channel by inflammation. Pyosalpinx, which was due to gonorrhoea in about 95 per cent. of the cases and to tuberculosis or *Bacillus coli* infection in the remainder, certainly caused incurable sterility.

3. For conception to be possible the ovary must produce healthy ova, but it was very difficult to say when it was not doing so. Age and the action of x-rays led to ovarian atrophy, and it might be presumed that when this atrophy had come about ovulation ceased. But there were other conditions that apparently interfered with normal ovulation—for example, anaemia, chronic taking of drugs such as morphine, certain febrile conditions and some nerve conditions, including pituitary disease. Obesity might come into this category. The factors that disturbed normal ovulation, or the influence, if any, of internal secretions on ovulation, were unknown. It would not be unreasonable to assume that the physical and chemical causes of defective ovulation acted by interfering with the maturation of the germ cells.

4. This condition was not strictly one upon which successful impregnation depended, since failure therein led to miscarriage, not to sterility. From this point of view, however, the cases that were hopeless and incurable were those of uterine tuberculosis, carcinoma and sarcoma of the body of the uterus, and uterine fibrosis.

When a childless woman who had been married for some years gave a history of regular menstruation without undue loss or unusual pain, and, on examination, the pelvic organs appeared to be normal, the case might be regarded as one of functional sterility. There were then several possibilities to be considered. Complete intercourse might not have taken place; or the husband might be at fault, suffering from azoospermia or from a deficient vitality of the spermatozoa; or, thirdly, it might be an instance of "sexual incompatibility." Of the conditions that caused or favoured sterility but allowed of treatment, some prevented normal intercourse—such as atresia of the vaginal orifice, stenosis of the vagina and rigidity of the hymen,

dyspareunia and vaginismus, and tumours encroaching on the vagina—all of these were more or less amenable to surgical treatment. Inasmuch as prolapse and proclivencia were usually the sequel of child-bearing, they were the cause of secondary rather than of primary sterility. The obstacle to intercourse was mechanical, and treatment gave a good prognosis. Conditions that allowed intercourse but interfered with ascent of the spermatozoa included under-development of the uterus; in this the prognosis depended mainly on the patient's age; if she was not much over 20, it might be an instance of delayed rather than of arrested development. The presence of either antelexion of the uterus or stenosis of the os externum must be regarded as very unfavourable to conception; but it could not be said that conception was impossible, and, from the point of view of prognosis following treatment, these were among the most satisfactory cases. Retroversion of the uterus, again, must be considered as unfavourable to conception, but not as definitely preventing it. In atresia of the os externum prognosis was hopeless without treatment, and not very good with it; but, nevertheless, an attempt should be made to restore the patency of the canal. Under the heading of polypus in the uterine canal might be included fibroid and mucous polypi and submucous fibroid, and in nearly every case the condition could be cured by operation. Endometritis sometimes caused absolute sterility by preventing conception, probably through the injurious effect of the discharge on the virility of the spermatozoa.

It was nearly certain that in cases of mild salpingitis without occlusion of the tubal ostia, conception could take place, and in all probability the sequel was often a tubal pregnancy. It might be supposed, however, that uterine pregnancy also followed, for cases were familiar in which child-bed fever was apparently due to the lighting up of a latent infection of the tubes. Obviously when salpingitis with occlusion was present conception was impossible; but within certain limits it could be remedied by operation—namely, in those cases in which there had not been extensive suppuration or damage to the tubes. An artificial ostium could be contrived by making an incision in the tube, near the ovary, and oversewing the edges, to prevent the opening from closing up again.

Dr. R. A. GIBBONS said that the average fertility of fertile marriages during the whole of the child-bearing period was ten. As the result of a voluntary confidential census among intellectuals, it was found that of 120 marriages, 107 were "limited," and that the average number of children of each marriage was considerably under two. Congenital sterility was rare, both in men and women; but the number of children in each family had steadily declined in recent years. He had known women who had started married life with a determination to avoid conception, and later had done all they could to cause conception and had failed. There were others who, having had one child, had resolved to have no more; and when, later on, they changed their minds, they were bitterly disappointed that all their efforts to procure a second child had had no result. The majority of men did not know the harm which might follow the use of preventives, especially to the nervous system of women with normal sexual feelings.

Mr. KENNETH WALKER had examined a number of husbands of women patients of Dr. Donaldson. In about 15 per cent. of the cases it could be stated that the husband was sterile, and in a still larger number something abnormal could be detected in the genitalia; there was either oligospermia or what might be regarded as an undue number of degenerate forms of spermatozoa, or signs of inflammatory trouble in the testes, prostate, or vesicles. If the vesicles of a rat were removed he remained fertile; the same was true after excision of the prostate. But if he were deprived of both prostate and vesicles he was sterile. Mr. Walker believed this to be confirmed by clinical experience, and it showed that the mere presence of spermatozoa in the semen did not prove that the male was beyond suspicion.

Dr. HERBERT SPENCER had given up dilating the uterus for sterility for nearly twenty years in favour of Pozzi's operation, and he had seen one case in which an under-developed uterus, which had been dilated unsuccessfully, had conceived at once, after seven years' sterile life, after performance of Pozzi's operation. He corroborated Dr. Gibbons's remarks on the frequent use of preventives and

their effect in causing permanent sterility. This was especially the case with quinine pessaries.

Dr. LOUISE McILROY said that the work of the future must go upon physiological and biological lines, and the effect of the internal secretory organs upon the reproductive functions must be studied further. The ovum should be looked upon as a temporary ductless gland; and in cases of repeated abortion for which no cause could be found there was sometimes evidence of the inhibitory action of the endocrines upon the growth of the ovum. Among cattle it was found that the massage of an ovary containing a persistent corpus luteum favoured fertilization in previously sterile animals. Dr. McIlroy was of the opinion that the Section should utter a protest against the growing use of contraceptive pessaries. Efforts to prevent the satisfaction of the maternal instinct when the sex instinct was stimulated at the same time were no doubt accountable for many gynaecological conditions and neuroses.

Dr. FAIRBAIRN felt that the cases that caused most difficulty were those without physical signs or mechanical causes; and he agreed with Professor Louise McIlroy that more biochemical research into the causes of sterility was needed.

Reviews.

CLINICAL DISORDERS OF THE HEART BEAT.

THAT within nine years, more than half of these disturbed by the war, no fewer than five editions of Dr. THOMAS LEWIS'S *Clinical Disorders of the Heart Beat*¹ have appeared bears eloquent testimony to the profession's opinion of the value of this clear statement of a difficult subject. It is surrounded, for the ordinary man, by a certain amount, if not of mystery, at least of the unknown in connexion with the electro-cardiograph and the polygraph, with which, as the means of investigation, he is familiar in name but not in deed. Dr. Lewis has given in full detail the evidence on which the modern conception of cardiac disorders and disease is based in many papers and other books, especially *The Mechanism and Graphic Registration of the Heart Beat* (reviewed in the BRITISH MEDICAL JOURNAL of July 31st, 1920, p. 166). Here, in a convenient form, he lucidly sets forth the practical conclusions required by the practitioner for his daily work.

In reply to the question, In what degree is an acquaintance with the graphic method essential or expedient in the routine of practice? Dr. Lewis answers that, though the acquisition of the necessary manipulative skill and experience demanded by the taking and interpretation of such records will often entail too much expenditure of time and energy to repay the practitioner or his patient, the practitioner should be thoroughly conversant with the new knowledge thus put within his reach. With this information in mind there are few important disorders of the heart which the unaided and practised senses cannot recognize. This handbook supplies this information by giving an account of the clinical picture, prognosis, and treatment of the seven forms of cardiac disorder—namely, sinus arrhythmia, heart-block, premature contractions or extra-systoles, simple paroxysmal tachycardia, auricular flutter, auricular fibrillation, and alternation of the heart—so clearly and authoritatively that every practitioner and student should have it in his possession and its teachings in his mind.

THE ENDOCRINE ORGANS IN GYNAECOLOGY.

The Endocrines,² by Professor BANDLER, is one of those books whose conversational if attractive title is a little misleading, for the work is not a comprehensive study of the subject so much as a somewhat limited consideration of the ductless glands from the point of view mainly of the gynaecologist. Written with the author's customary fluency, it is pleasant reading, and its perusal will undoubtedly repay those who foresee in the subject a vast

field for much work, and, it is to be hoped, successful and beneficent employment in the near future of gynaecology. The structure of the book suggests that it has been composed in part by the conglomeration of several separate papers. This may, perhaps, be the explanation of an unnecessary discursiveness on subjects which are not always obviously germane to the main thesis.

Professor Bandler begins by a long discussion of heredity and environment, written in a most grandfatherly style, in the course of which he makes many interesting observations on the emotions and characters of childhood, adolescence and maturity, and gives much prudent advice on education and upbringing. In a subsequent chapter he is led to emphasize the study of the inheritance of tendencies to aberration in the inter-relationship of the ductless glands; the recognition of such tendencies will, it is thought, provide the physician with a fund of foreknowledge that may well prove a powerful and effective instrument in his dealings with his patients. A brief systematic study of the different individual glands and their functions prefaces a chapter on the particular bearings of the different hormones on gynaecological conditions, especially upon puberty, the menopause, and menstrual disorders. The possible influence of the internal secretions on the causes of sterility forms a peculiarly interesting chapter. Then follow sections indicating the part played by the secretions of the endocrine glands in connexion with the emotions and instincts, phobias, and mental and nervous defects and deficiencies. Lastly, there is a chapter on the all essential balance of the different secretions. The later part of the book deals with endocrine therapy, with methods of investigations into endocrine defects, and with the author's own case records.

Altogether Professor Bandler has produced a most interesting volume, and while it may be felt that several of the views he strenuously upholds still await confirmation, not to mention proof, it may well be that for this very reason his book will be found the more stimulating to thought, and probably also to methods of treatment, some of which are still in large measure empirical. It is impossible to read such a book as this without feeling that, while we are certainly on the verge of great discoveries, we are just as likely to be entering on a period when potent hormones will be widely employed as drugs with the same lack of discrimination as characterizes vaccine therapy in many hands—guided, it may be, more often by the seductive advertisements of the manufacturing chemist than by knowledge. But the discovery of the truth is never to be hustled. There are to be found in Professor Bandler's pages warnings against a merely ignorant optimism, but let not his readers be carried away too completely by the infection of his enthusiasm when, for example, he breaks out into prophecy. "In five years there will be few mental defectives (new), few insane (new), few tumours (new), few cancers (new), few diabetes (new). Since they are due to endocrine aberrations they will be corrected in their earliest stages by endocrines. When the next war comes soldiers going over the top will not be given alcohol; they will be given endocrine cocktails, and adrenal cortex will be an important ingredient." His experience as an obstetrician should have made the author particularly chary of committing himself to prophecy. But perhaps this is a mental by-product of a "dry" America!

THE TREATMENT OF THE NEUROSES.

Dr. ERNEST JONES devotes the major portion of his book on the *Treatment of the Neuroses*³ to an account of hysteria and a critical survey of the various physiological and psychological measures which have been suggested for its treatment. The views developed in this chapter are largely applicable to the psychoneuroses generally, and are here grouped under the one heading of hysteria in order to avoid needless repetitions in dealing with other forms of disorder. The author gives an excellent description of the hysterical personality, and in providing a lengthy summary of the various therapeutic methods of approach he clearly indicates their value and limitations, and has many pertinent criticisms to offer. As an exponent

¹ *Clinical Disorders of the Heart Beat*. A Handbook for Practitioners and Students. By Thomas Lewis, C.B.E., M.D., D.Sc., F.R.S., F.R.C.P. Fifth edition. London: Shaw and Sons, 1920. (Cr. 8vo, pp. 140; 54 figures. 8s. 6d. net.)

² *The Endocrines*. By Samuel Wyllis Bandler, M.D., Professor of Gynaecology, Post-Graduate Medical School, New York. Philadelphia and London: W. B. Saunders Company, 1920. (Med. 8vo, pp. 494, 35s. net.)

³ *Treatment of the Neuroses*. By Ernest Jones, M.D., Lond., M.R.C.P., Lond. London: Baillière, Tindall, and Cox, 1920. (Demy 8vo., pp. viii+253, 10s. 6d. net.)

of Freudian views in this country. Dr. Jones devotes particular attention to psycho-analysis as a form of treatment, and here becomes a strong partizan rather than a critic.

It is difficult to avoid the reflection that if the author had shown the same critical attitude towards the system he so strenuously supports as he does towards alternative methods of treatment his book would have been a contribution to medicine of considerably greater value. He is much less convincing as an advocate than as a critic, and his attitude towards his own subject is dogmatic rather than persuasive. Especially is it to be regretted that the author still finds it necessary to deny the possibility of an objective standpoint on the part of the opponents of his doctrines, and that, in advocating his views, he is unable to avoid a discussion of the mental state of those who find themselves unable to agree with him. Can it be that the select coterie of Freudian adherents are the sole exponents of a scientific attitude towards the problems of mental life? The method upon which Dr. Jones bases his views would seem to involve the interpretation of phenomena on the basis of a system of beliefs already held by the observer to an extent which would not be considered permissible in any other branch of science, for he writes as follows:

"As was indicated above, the material gained in these various ways is then submitted to a process of elaboration and elucidation, whereby the same characteristics in different parts are brought together, correlations established, obscurities clarified, and underlying connexions and meanings made plain. The resulting interpretations are made use of to direct the patient's attention towards the more hidden material for which they furnish clues. The technique of psycho-analysis comprises innumerable minor rules dealing with the interpreting of material, and with the difficult question of how to decide the right moment for conveying the interpretations to the patient." (Page 136; italics ours.)

Surely the scientific validity of this method is at least open to question, and Dr. Jones should not be surprised if many psychologists hesitate to accept a view of mental life and development based upon a mode of investigation in which suggestion is admitted, and can, indeed, scarcely be avoided.

A STANDARDIZED BINET-SIMON SCALE.

THE growth of the use of mental tests on the Binet-Simon lines both in schools and in courts of justice, has suggested the desirability of standardizing these tests so that the results obtained in the investigation of mentality may be to some extent interchangeable and of value in communication between those interested in a given case. Hitherto no manual has appeared which embodied a uniform method of dealing with such questions as the following: With what tests should the examiner begin? Which of two alternative questions should first be employed in a given case? Under what conditions may a test be repeated? A few years ago a series of experimental investigations in the testing of mentality were instituted by Mr. NORBERT J. MELVILLE of Philadelphia. The results of this research are embodied in a book entitled *Standard Method of Testing Juvenile Mentality by the Binet-Simon Scale and the Porteus Scale*.⁴ The conduct of the investigation necessitated the training and supervision of several hundred co-workers and the valuation of the results of some thousand Binet tests. The work was done in a number of public schools in New York, Princeton, and Philadelphia. The results of Binet tests, it is pointed out, do not always tally with the known state of scholarship. The Binet scale was expressly designed so that it should not be a direct test of school knowledge but of juvenile mental development. The scale determines how much an individual has profited from some typical forms of experience and training which the majority of children in civilized countries undergo, not only in school but also in the home and in the playground. The book is divided into two parts. The first deals with the nature and scope of the tests, their manner and order of usage, and the materials to be employed. The second gives a series of standardized tests for each age. The tests are

⁴ *Standard Method of Testing Juvenile Mentality by the Binet-Simon Scale and the Porteus Scale of Performance Tests*. By Norbert J. Melville. Philadelphia; with an Introduction by William Healy, M.D., Director of Juvenile Psychopathic Institute, Chicago. Second enlarged edition. Philadelphia and London: J. R. Lippincott Co. 1921. (Cr. 8vo, pp. 162; illustrated. 12s. 6d. net.)

actually given in the pages of the book in questions, drawings, and coloured diagrams. These pages are undercut so that reference is facilitated.

In the introduction, written by Dr. William Healy, there is a necessary warning that people of sound training and good judgement are needed to use these methods for the better study of human beings.

A MEDICAL TEXTBOOK FOR NURSES.

NURSES are charged with the responsibility of carrying out the orders of the medical man, and it is claimed by Dr. FORTESCUE-BRICKDALE in his *Textbook of Pharmacology and Medical Treatment for Nurses*,⁵ that this function will be performed with more accuracy and intelligence the more nurses appreciate the ideas which underlie their instructions. With this principle we agree.

The book is divided into two parts. Part I deals with pharmacology, and in very simple and concise language gives an account of the action of the ordinary medicinal remedies. Technical terms are for the most part avoided, and no doses are given. It is a good feature of the book that in the discussion of any drug or group of drugs the various proprietary remedies which have come into use, and which are copies or slight modifications of well-known drugs, are described. This is of some importance, as in these days the nurse as well as the medical man is circled by the vendors of proprietary remedies, and her education affords her no means of forming an opinion. It might have been well had the writer taken the opportunity of impressing on his readers the fact that proprietary remedies, with few exceptions, are either drugs in the experimental stage or mere commercial speculations, and to point out that when a drug is proved to be of value it is included in the *British Pharmacopoeia*.

The book is well illustrated by anatomical diagrams, for example, of the heart when digitalis is discussed; by pictures of plants, sometimes coloured, and by tracings which show the action of drugs clearly, and are easily understood. This part also contains an account of vaccine and serum treatment, and of ortho-therapy. The author has explained in simple language the foundation of medical treatment, and we have few criticisms to offer. Perhaps he deals with ions more fully than is necessary, and opsonins, even if they exist, are of no importance to nurses.

Part II deals with treatment, but wisely contains no clinical or pathological details. A nurse ought to know the nature of the disease from which her patient is suffering, and be familiar with the routine methods of treatment, and the object of the present part is to explain the rationale of this treatment. The diseases are arranged according to organs, such as diseases of the urinary organs, respiratory system, fevers, and so on, and special stress is laid on that portion of the treatment which the nurse is expected to carry out. The illustrations in this part also are good and helpful. It is a pity that more is not said on methods of administering remedies, the masking of tastes, preparing and administering hypodermic injections and details of disinfection, and less on the medicinal treatment of symptoms such as, for example, those that may occur in locomotor ataxy. It is doubtful whether anyone without a knowledge of physics could understand Appendix III, which gives the scientific basis of radio-therapy. The book is admirably printed in large type, and is very free from errors. It is the first book of its kind, and we can whole-heartedly recommend it to every one who is taking up nursing as a profession.

A SYNOPSIS OF PHYSIOLOGY.

Physiology,⁶ by Dr. FRANGCON ROBERTS, in the Students' Synopsis Series, is a small book "definitely addressed to those who are already acquainted with the elements of the subject, and is intended to supplement the larger textbooks." It is not a mere cram book or a boiled down edition of the larger textbooks, it is a synopsis in which the salient features of the subject are well brought out, and, in the case of the chapter on intermediate metabolism,

⁵ *A Textbook of Pharmacology and Medical Treatment for Nurses*. By J. M. Fortescue Brickdale. London: Henry Frowde, and Hodder and Stoughton. 1920. (Double Roy. 8vo, pp. 495; 77 figures, 3 plates, 25s. net.)

⁶ *Physiology*. By Frangcon Roberts. Students' Synopsis Series. London: J. and A. Churchill. 1920. (Cr. 8vo, pp. 537; 75 figures, 15s. net.)

very well presented. The arrangement is good and logical, and only a few actual errors have been detected. The illustrations on the whole have been well selected, and do illustrate the points intended.

A GUIDE TO NEUROLOGICAL DIAGNOSIS.

THE guide to neurological diagnosis,⁷ written by Dr. K. SINGER, and published in Berlin, is arranged on clinical lines, being divided into chapters on paralysis of peripheral and central origin, disturbances of sensation, conditions of increased and diminished reflex activity, fits, and so on. A certain amount of anatomy and physiology and a medium of pathology are introduced. A serious drawback is the absence of any really good illustrations or figures in the text. Such figures as do occur cannot be praised, and in this respect the book compares unfavourably with similar British or American publications. We have noticed strange omissions. Thus, in the section devoted to paralysis from spinal cord lesions we find no reference to the experiences of the neurological injuries of war and particularly to the work of Head and Riddoch in this respect. The account given of disturbances of sensation arising from cerebral lesions, again, is altogether inadequate. In a very brief paragraph on the etiology of multiple neuritis no mention is made of acute toxic polyneuritis. The chapter on disturbances of speech follows quite conventional lines, is very short, and hardly adequate for so large a subject.

Diseases of the sympathetic nervous system receive very scant consideration, particularly in view of the large amount of interest the subject has recently aroused. For a book bearing the date 1921 it does not fulfil expectations.

THE CONTRIBUTION OF MEDICINE TO HISTORY.

THE influence of variations in the health of kings and ministers and other persons of political importance on the course of events is a department of history which has attracted more attention in France than other countries, probably because for some three centuries that country was an effective autocracy where the state of mind of the ruler—a fit of depression or a spasm of exaltation—might have immediate and serious effects on policy. Interest in the subject and his belief in the influence of breeding and heredity combined to disturb the judgement of Michelet, and sometimes perhaps biased even Taine. It has been a favourite side study with many members of the medical profession in France, and it has been for thirty years the main occupation of Dr. Cabanès of Paris; he is the author of a whole shelf full of very readable books, and the editor of a monthly periodical, the *Chronique Médicale*, which gives hospitality to a multitude of scraps of curious information, mainly biographical, and contains during a year a number of longer articles often of considerable historic interest and importance.

During the winter before last Dr. CABANÈS gave a course of lectures in Brussels; these he has revised, and they are now published in a volume entitled *L'Histoire éclairée par la Clinique*.⁸ Some parts of the volume are more solid fare than the author is accustomed to offer his readers. The earlier chapters are concerned with the importance of science in general to the study of history, and the real subject of the book is only reached when he comes to discuss the help medicine can give to the historian by enabling him in the first place to recognize the mental or bodily disorders, permanent or transitory, of political personages, and, in the second, to appraise correctly the effect of such disturbances on public affairs. Dr. Cabanès gives some examples of the way in which a minute study of details may sometimes suggest probable explanations of peculiarities of conduct that have puzzled contemporaries and historians alike. To one of these we make reference elsewhere. Dr. Cabanès is a judicious guide; he is an enthusiast for his subject, but anxious to make a just estimate of its importance. His final chapter, in which he sums up the lessons he has learnt during the many years he has given to the study of the relation of medicine to history, should be read by professed historians as well as by medical men who take an interest in the philosophy of history or even in its biographical and anecdotal byways.

⁷ *Leitfaden der Neurologischen Diagnostik*. By Dr. Kurt Singer. Berlin and Vienna: Urban und Schwarzenberg. 1921. (Sup. roy. 8vo, pp. 216; 33 figures, M.45.)

⁸ *L'Histoire éclairée par la Clinique*. By Dr. Cabanès. Paris: A. Michel. 1921. (Demy 8vo, pp. 320.)

NOTES ON BOOKS.

TUBERCULOUS salpingitis forms the subject of the most recent fascicule of the *Johns Hopkins Hospital Reports*.⁹ The writer, Dr. J. H. GREENBERG, has made a painstaking study of the 200 cases in the hospital gynaecological records; the conclusions he has been thus enabled to reach are instructive and of particular value on account of the large amount of material on which they are based. The general incidence of the condition amongst 24,000 gynaecological patients was found to be just under 1 per cent.; amongst all forms of salpingitis it accounted for 7.5 per cent. Tubercle bacilli were found in 20 out of 25 cases specially stained for the purpose. Tuberculosis of the uterus was proved to coexist in 45 per cent., but its true coincidence is suggested as being more probably about 72 per cent. Cervical tuberculosis was present in only 3.5 per cent., and vaginal tuberculosis in 0.5 per cent.; peritoneal involvement existed in 63 per cent., and the appendix was found to be tuberculous in 3 per cent. Four cases (2 per cent.) had associated tuberculosis of the urinary tract. The mortality in hospital was 8.5 per cent., and of those operated upon 7.6 per cent. A full bibliography is given. Dr. Greenberg is to be congratulated on a good piece of work, which will be of value for purposes of reference.

In his volume, *De l'Anaphylaxie à l'Immunité*,¹⁰ Professor MAURICE ARTHUS of Lausanne, whose name is so familiar in connexion with Arthus's phenomenon or local gangrene at the site of repeated injections of horse serum into a rabbit, has collected together the results of more than fifty of his papers published on this subject since 1903 and based on 2,500 experiments. This record of devotion to a difficult subject contains in a convenient form Professor Arthus's numerous observations on anaphylaxis, protein poisons, snake poisons, antivenomous serum, and anaphylaxis-immunity. It is a statement of indefatigable experimental research, and acting up to his motto, "beware of theorists and of theories," he refrains from embarking on hypotheses. He finds that in the dog anaphylaxis, both active and passive, is specific, whereas the rabbit is an exceptional animal in that anaphylaxis is not specific. His experiments convince him that the cells of the central nervous system are not directly acted upon by toxic proteins or in anaphylaxis, thus differing from the general opinion as to the production of anaphylactic shock. On the question whether anaphylaxis and immunity are modifications of the same condition or are independent states, he concludes that they are distinct.

The two periodicals *Psychobiology* and the *Journal of Animal Behaviour* have been merged under the new name of *The Journal of Comparative Psychology*.¹¹ The journal will be edited by KNIGHT DUNLAP, Johns Hopkins University, and ROBERT M. YERKES, National Research Council, in association with a number of prominent American psychologists. It will be issued bi-monthly, and the *Behaviour Monographs*, which are issued irregularly, will be continued in connexion with the new journal. Studies which contribute to the knowledge of mental function and behaviour of any organism will be accepted for publication. The new periodical is expressive of the increasing tendency of psychology to develop into an objective science, and it will no doubt furnish contributions of much value to the understanding of animal and human behaviour. The first number (February, 1921) consists of two interesting contributions. John Linch Ulrich writes a second instalment of his researches on the "Integration of movements in learning in the albino rat," and English Bagby writes on "The psychological effects of oxygen deprivation."

The number of books intended to give the young mother information needed for the preservation of her own health and that of her infant is now very large. Among the best is *Mother and Child*,¹² by Dr. EDWARD P. DAVIS, of Philadelphia. In revising the text for the fourth edition he has taken the opportunity of warning older women against some common fallacies. There are many illustrations, most of them helpful, though the picture of a bassinette looks as though it came from a tradesman's catalogue, and some others might have been omitted without really detracting from the value of the book.

⁹ Volume xxi, Fasciculus II. Baltimore. 1921. (Pp. 97-156; 2 plates.)

¹⁰ *De l'Anaphylaxie à l'Immunité*. Par Maurice Arthus, Professeur de Physiologie à l'Université de Lausanne. Paris: Masson et Cie. 1921 (Pp. xxxvi + 363. Fr. 20.)

¹¹ *The Journal of Comparative Psychology*. Edited by Knight Dunlap and Robert M. Yerkes. Baltimore: Williams and Wilkins Co. Vol. 1, No. 1, February, 1921. Price per volume, 5.50 dols.

¹² *Mother and Child*. By Edward P. Davis. A.M., M.D. Fourth edition, revised. London: J. B. Lippincott Company. 1921. (Crown 8vo, pp. 294. 12s. 6d. net.)

THE FEDERATION OF MEDICAL AND ALLIED SOCIETIES.

ANNUAL DINNER.

THE annual dinner of the Federation of Medical and Allied Societies took place at the Café Royal on May 26th. Sir BERKELEY MOYNIHAN, the President of the Federation, was in the chair, and among those present were Dr. Addison, M.P., Sir Alfred Mond, M.P., Lord Dawson of Penn, Lord Queenborough, Viscount Knutsford, Sir George Newman, Sir H. Kingsley Wood, M.P., Dr. Nathan Raw, M.P., Dr. Donald Murray, M.P., Sir Philip Magnus, M.P., and Dr. F. E. Fremantle, M.P. The company numbered just over a hundred, and included representatives of thirty-eight separate societies of the medical and allied professions.

Sir BERKELEY MOYNIHAN, in proposing the health of Dr. Addison, said that the late Minister of Health had been subjected to a considerable amount of criticism, but that was an atmosphere in which politicians thrived. Some of the criticism had been timely, wise, and helpful; some of it had been silly, displaying poverty of imagination and even of invective; and some of it had been malignant, though in the part of the country from which he came he had never discovered any metastatic deposits from that malignant focus. He knew Dr. Addison many years ago when the future statesman was an anatomist. He bitterly regretted that Dr. Addison had deviated—he would not express it in terms of pathological degeneration—towards politics. Had he remained an anatomist he would now have been the first anatomist in the Empire. He wrote a work on the topographical anatomy of the abdominal viscera, especially the gastro-intestinal canal. "I have perhaps as friendly and intimate acquaintance as anybody," said the speaker amid laughter, "with most of the abdominal viscera, and I can assure Dr. Addison that the viscera appreciate very much the work he has done on their behalf. Those who have to teach the topographical anatomy of the abdominal viscera to students to-day have to refer to the work of Addison. So far at least as anatomy is concerned, Dr. Addison's name is immortal." Dr. Addison's appointment as first Minister of Health (he continued) was received with acclamation by the whole profession. It needed courage to accept the office. It was not incongruous to suggest at that table that there were some present who might well have been thought of in connexion with the post, but he would like to ask them and to ask himself—for the "Gentleman with the Duster" had put him in the ideal Cabinet as Minister of Health—if any one of them could have done so much and so well in so short a time. There could be no discordant voice in the profession as to Dr. Addison's aims, even though there might be difference as to his procedures. He had had not only to overcome ignorance, but to fight against the stultifying imperviousness to new ideas. And he had done things which no man would ever be able to change. It had to be remembered, of course, that his plans were conceived in a time of national prodigality, and had to be put into practice in a time of national poverty. But he (Sir Berkeley) would plead with those whose voice had any weight with the people in authority that the last direction in which economies were insisted on should be the broad highway which led to national health. The whole profession owed a great debt to Dr. Addison, who would be astonished if he knew what backing he had from general practitioners. The Federation also owed him a debt because, at the very beginning of its history, he, standing high in the councils of the nation, had pleaded for a united profession. There was a profession of divided counsels and jarring factions; its interests were not necessarily conflicting, but pains seemed to be taken very often to make them so. The speaker concluded with a happy allusion to the rod of Aesculapius, likening Dr. Addison to the god Mercury, who threw his staff among the quarrelling serpents, so that they twined themselves around it henceforth in friendly co-operation.

Dr. ADDISON, in reply, expressed his thanks for the cordiality with which he had been received, and praised the aim of the Federation to bring together the medical and allied professions, and to foster among them a lively interest in public questions. To those who had eyes to see it was clear that, whatever might be the ebb and flow of events, society would seek more and more to enlist the aid of those who could best help it to promote the physical well-being of its members and to prevent avoidable disabilities. The mass of avoidable disability was strikingly revealed during the war, and it was because of this that the dominant purpose of the Ministry of Health, at least in the early stages of its history, must be to develop and

encourage all preventive agencies. In order to do this a long view was necessary. Opportunist spectacular performances were not the function of such a Ministry. He might give many illustrations on this point. The Ministry, for instance, had inaugurated a system whereby assistance was rendered to port sanitary authorities in order to prevent the invasion of post-war pestilence. The total cost of this scheme was £65,000 in this year's estimates. Owing to the vigilance and efficiency of the sanitary authorities the country had been kept free from any such epidemic. This trifling insurance had enabled us to escape a disaster which would have been hundreds of times more costly than the insurance itself. But such a piece of prevention did not lend itself to headlines, and the kind of critic who went in for terminological fireworks could see no definite return for the money spent. The same was true of the expenditure on maternity and child welfare. The extra grants, entailing the expenditure of a few thousands, which had been made with a view to increasing the efficiency of nurses, health visitors, and others, by means of special training classes, had contributed to no small extent to the striking improvement in infant welfare statistics. A recent vote in Parliament to cover a week's loss owing to the railway strike equalled the total expenditure by the Exchequer on the whole of the maternity and child welfare services in England and Wales for seven years. He was interested to see that one of the most flamboyant critics of his health expenditures had not hesitated to press for one more super-dreadnought over and above the Admiralty requirements, and that leviathan, if it were voted, would bury an amount equal to six or seven years' expenditure by the Exchequer on maternity and child welfare. Frankly, he himself would place the interests of British babies before the building of barracks in Baghdad. In conclusion Dr. Addison referred to his housing scheme, two features of which, he said, would gradually come to be realized: first, the condition that no local authority or private builder could build more than a certain number of houses to the acre; secondly, the condition, coming into force in 1923, whereby all the major authorities of the country would be required to provide a town-planning scheme to govern the future development of their districts. This would lead to the gradual elimination of the biggest blot on our industrial system—namely, the inconsiderate crowding together of masses of the population, without regard to the needs of the people or the claims of the future.

Sir MALCOLM MORRIS, Vice-President of the Federation, was in charge of the toast of the Minister of Health. In proposing it he briefly reviewed the history of the Federation, which began, he said, in an effort to increase the number of medical men in Parliament. The medical men in the House of Commons numbered twelve at the present time. It was desirable that they should have fresh accessions. He hoped particularly that a woman doctor would find her way into Parliament to accompany the solitary lady who at present sat on the green benches. He hoped also that Lady Rhonda, whose interest in health questions was so acute, would secure admission to the House of Lords. The Federation had gone on to a wider effort to bring together the various organizations entitled to speak for the medical and allied professions. The central council of the Federation did not initiate schemes and then appeal to the constituent bodies. The Federation had no central policy, beyond that of providing a round table for conference. Its object was simply to secure the greatest common measure of effective opinion. It was faced with one great difficulty—the aloofness of the British Medical Association. As one of the officers of the Federation he would like again to offer to the British Medical Association the right hand of friendship. The Federation was not in antagonism to the Association; it did not want to interfere with the Association's autonomy, and it appreciated enormously the good work which the Association had done in the past. But on these health questions they ought to speak as one body, including all who were immediately concerned in national health.

Sir ALFRED MOND, in his response, agreed with the sentiment of the proposer that it was desirable that the medical profession should speak with unanimity and decision on questions of public health. When experts differed it was easy for the scoffer to refuse to listen to either party, and correspondingly hard for those who were responsible for administration. Proceeding, he said that he had himself fallen on evil days: not only did a layman succeed a medical man, but his predecessor began his work at a time when it was assumed that the purse of the nation was bottomless, whereas he took office when the nation was buttoning up its pocket. A Minister had to keep in his hands the clinical thermometer of the House of Commons and to watch the temperature chart of public

opinion. It was not for him to have recourse often to violent drugs which killed or cured, but rather to seek the aid of safer old-fashioned remedies which might produce some amelioration of the patient's condition. While it was difficult to advocate a launching out in many directions he deprecated any forfeiture of what had been gained of recent years. At the present time he was waiting for the report of Lord Cave's committee, and was doing all he could to expedite it. No one could contemplate without dismay the closing down of beds in hospitals. It was inconceivable that these great institutions should be allowed to curtail their operations; it could only be a question of ways and means of re-establishing them. He agreed with Dr. Addison that preventive medicine was not spectacular; indeed, if he wanted to achieve undying fame he would allow some great epidemic to break out, and then show with what energy his department could combat it. Medical research had to go hand in hand with preventive medicine. Without knowledge it was difficult to prevent, and even more difficult to cure. He hoped that some lessons would be learned from war strategy, and that disease would be attacked more and more in mass formation and not by solitary sniping. With the development of science he looked to the time when there would be no disease at all, in which case both the Ministry of Health and the medical profession would become extinct, unless, indeed, the community followed the example of the Chinese and remunerated doctors according to the number of days in the year that they were well. He paid a tribute to the value of medical men in the House of Commons, and added that he would always receive with gratitude any suggestions that the Federation might make to him.

Dr. FREMANTLE, M.P., in proposing the toast of the Federation, described himself as its parliamentary baby, for he owed much to its help in winning his by-election. Like Sir Malcolm Morris, he desired to hold out the hand of fellowship to the British Medical Association—an Association with so distinguished a record behind it. It was only as a loyal member of the Association that he proposed the toast. The organization of the Association was the most complete and logical scheme that could be based on a democratic principle. Any member of the profession who joined the Association found himself immediately related to its affairs, alike through its weekly JOURNAL, edited with such extraordinary ability, and through its local organization. But the Association had only managed to enrol two-thirds of the profession. He thought that a more fluid method of collecting and expressing opinion was called for, excellent as the Association's method was from the purely democratic point of view. Even among the Association's membership there were many who took no interest whatever in the procedure which was supposed to bring about their representation in the Representative Body and the Council. He did not despair of the democratic method, but some more adaptable arrangement seemed to be also required, and, moreover, the opinion of allied professional bodies should be elicited.

Dr. ARTHUR LATHAM, in responding to the toast, said that while certain individuals were resentful of new ideas, he did not believe that the British Medical Association in its constituencies was really hostile.

ANAPHYLAXIS AND IMMUNITY.

LECTURE AT THE ST. MARY'S HOSPITAL INSTITUTE.

THE lecture contributed by Dr. H. H. DALE, F.R.S., to the series on pathological research in its relation to medicine, which is being given at the Institute of Pathology and Research, St. Mary's Hospital, London, was on anaphylaxis and immunity.

He began by pointing out that anaphylaxis was not the opposite of immunity. It did not represent, as Richet at first thought it did, an increase of sensitiveness to a naturally poisonous substance. Anaphylaxis was a condition in which an animal responded by just the same type of reaction to normally harmless substances to which it had been rendered specifically sensitive as to poisonous ones. It might be defined as a condition of abnormal sensitiveness to a foreign protein, so that, whatever the nature of the action of the protein in question, whether ordinarily poisonous or not, the animal reacted to it as though it were an acute poison of a particular type. It was important to bear in mind that the characteristic of anaphylaxis was not the appearance of symptoms but the mode of their production. In the mode of its production and in its specificity anaphylaxis resembled immunity, though its effects seemed to be so strikingly different. The resemblance was strengthened when it was remembered that the condition of anaphylaxis, like that of immunity, could be transferred from one animal to another.

Passive anaphylaxis, caused by the transfer of serum from the anaphylactic animal to the normal animal, did not operate immediately; an interval of from twelve to twenty-four hours after injection was necessary, even when the injection was intravenous, before the transfer of passive sensitiveness could be detected.

Practically all workers, with the conspicuous exception of M. Besredka of the Pasteur Institute, were unanimous in their opinion as to the nature of the anaphylactic antibody. It was generally recognized that the anaphylactic antibody was not a peculiar new kind of body, but one which had been long familiar to immunologists as precipitin. The evidence for this was not complete, but was complete enough to make any other assumption unnecessary. The limits of the specificity of the anaphylactic reaction were very closely similar to those of the precipitin reaction. The serum from the anaphylactic guinea-pig would convey the sensitiveness to a normal guinea-pig. The anaphylaxis so conveyed was not of a high degree, and a large quantity of serum from the anaphylactic animal was needed to transfer it. Much more efficient in transferring passive anaphylaxis was the serum from a rabbit which had had a series of injections of the antigen. The rabbit precipitin, injected into the guinea-pig, rendered the guinea-pig exquisitely sensitive to the antigen. If the anaphylactic antibody was not identical with precipitin, at any rate it was closely parallel in its formation. One fact, however, seemed almost fatal to this theory. The presence of precipitin could not be discovered in the serum of the anaphylactic guinea-pig; at least, the ordinary coarse precipitin reaction could not be obtained, though the presence of some reaction might be discovered with the ultra-microscope. On the other hand, if the guinea-pig, before it had time to become sensitive, were given not one but a series of injections of the antigen, an obvious precipitin in the guinea-pig serum was ultimately produced, but by this time the animal was not anaphylactic, and would tolerate large doses of antigen without harm.

Up to this point there was substantial agreement among immunologists; but two distinct theories now made their appearance. The first, which Dr. Dale said did not satisfy him, supposed that the reinjection of the antigen into the anaphylactic animal caused the production in the blood of a poison having a certain type of action, and to this hypothetical poison the name of "anaphylatoxin" had been given. Recently there had been a tendency to ascribe its formation to a physical rather than a chemical change. Some vaguely comprehended change in the state of colloidal equilibrium, something similar to the changes which preceded the clotting of the blood, was supposed to give rise to this anaphylatoxin. Dr. Dale, however, was not convinced of the direct connexion of anaphylatoxin formation with the phenomena of anaphylaxis. If a poison of this kind were really formed in the blood, an obvious way of producing the anaphylatoxin *in vitro* would be to mix the blood or serum of the anaphylactic animal with the antigen and inject into a normal animal. That did not work; there had been apparent successes, but in the vast majority of cases such injection was innocuous. More effective still should it be to inject into the blood simultaneously the antibody and the appropriate antigen; but that again did not work. The animal which was given the antibody and the antigen at the same time remained unhurt. Only when the antibody had been in the body for some hours did sensitiveness begin to appear, and not until it had been there for twenty-four hours or more did sensitiveness reach its maximum.

The other theory, and the one which the lecturer commended, offered an explanation for the fact that, after the antibody had been introduced into the normal animal, some hours had to elapse before sensitiveness began to appear. The antibody when circulating in the blood was not sensitizing but protective, and it had to get out of the blood before anaphylaxis could be produced. When once the anaphylaxis was fully developed, the injection of a further large dose of the antibody, instead of increasing the sensitiveness, immediately depressed it, so that the animal again became insensitive. He had repeated that experiment, and it worked. The obvious suggestion was that the antibody, when out of the blood, fixed itself in the body cells, and by its presence there and its reaction with the antigen, brought about something in the nature of precipitation in the sensitive cell protoplasm or

membrane, and that it was this which gave rise to the anaphylactic phenomena. On the other hand, excess of antibody, free in the body fluids, would bring about immunity because it caught the antigen and put it out of action before it reached the cells.

Anaphylaxis, therefore, was not the opposite of immunity, but a particular expression of the immune condition, due to the location of the antibody predominantly in the living cells instead of in the fluids bathing them. This explained why an interval was necessary after the injection of the pre-formed antibody before the animal became passively anaphylactic. It explained why the presence of sufficient antibody to circulate freely in the blood rendered the animal again relatively insensitive. Dr. Dale believed that this anaphylactic reaction represented a very fundamental type of resistance of the body cells to the incorporation into their protoplasm of a protein with a molecular pattern alien from their own. To resist this vitiation of its specific type the cell would die for the individual, or, if the body cells were subjected simultaneously to the attack, the individual would die for the purity of the species. The only chemical difference known between different species was a difference in proteins. The carbohydrates and fats were of a common type over a very wide range of species. It was in the molecular pattern of these complicated proteins, with its tangled skein of amino acids, that one had a chance of discovering the chemical difference which could be related to a specific or even an individual type.

Dr. Dale touched finally and slightly on the question as it affected practical therapeutics. There were some, he said, who would have them believe that the whole of the phenomena in patients suffering from an acute septicaemia could be explained in the terms of anaphylactic reaction. There was no warrant as yet for making such an assumption. Symptoms of the type seen in the anaphylactic reaction did not necessarily indicate anaphylaxis. There were, however, certain phenomena seen in man which suggested a close connexion with this condition. He instanced the rash and constitutional disturbance following the injection of horse serum, significantly after ten days' interval; also the various idiosyncrasies to foreign proteins seen in hay fever and "horse asthma," which had—to speak guardedly—many points of similarity to the anaphylactic condition.

THE INFLUENCE OF THE DUCTLESS GLANDS IN EVOLUTION.

PROFESSOR L. BOLK of Amsterdam, in a lecture to advanced students of the University of London, delivered on May 12th, dealt with the somatic changes in affections of the endocrine organs and their significance in the evolution of man. He raised many points of extreme interest, and made suggestions which were novel and often daring if not far-fetched, though Professor Gley's speculations (BRITISH MEDICAL JOURNAL, May 8th, 1920, p. 644) may have prepared our readers for them.

Dr. Bolk said that he had always been a strong supporter of the Darwinian hypothesis, and now maintained that the results of his researches were in no way inconsistent with, but rather afforded every confirmation of, the belief that Darwin had provided the correct solution of man's origin. Professor Bolk maintained that the various endocrine glands not only bore a definite and harmonious relation to each other and the organism as a whole, but that they had played a comparable part in the evolution and development of man from his primeval ancestry and origin. They exercised a sort of *imperium in imperio* of a suppressive or retarding character, without which the human race would never have attained its present state of civilization and dominance over the animal kingdom and realm of nature.

In support of the conclusions which he had formed from his research into the problems of endocrinology and evolution, he described certain features peculiar to man as representing the persistence of a primitive condition exhibited during foetal life by primates and higher apes. The hairlessness and absence of pigmentation of the skin in the white races were attributable to the retarding influence of hormones of the suprarenals on the distribution of hair and development of pigment which had taken place in the course of racial evolution. The specimen of a chimpanzee foetus at term, shown by the

lecturer, displayed characteristics so far human that pigment and hair were absent from the whole surface of the body save the scalp. It was in consequence of the withdrawal of the suppressive action of the suprarenal secretion after birth that the skin of the ape became hairy and pigmented.

The superiority of the fair-skinned, light-haired and blue-eyed races over the pigmented and negro races might be traced *pari passu* with the extent of the retarding functions exercised by the endocrine glands on racial development. As evidence of the arrest of this function in the suprarenals in man was quoted the well-known pigmentation or bronzing of the skin occurring in Addison's disease.

To the retarding effect of the internal secretion of the thymus gland was attributed the delayed union of the cranial bones and open cranial sutures which had allowed of the growth and development of the human brain to its present eminence. On the other hand, by the removal of the inhibitory action of this particular hormone, there occurred premature closure of the sutures and irregularities in the normal rate of ossification, resulting in various rachitic manifestations.

Further examples of somatic evolutionary changes due to the activity of the endocrine glands and the retarding influence of their hormones were described. The pituitary gland was held responsible for the present conformation of the human skull and increase in capacity of the cranial cavity, the development of the chin, the retraction of the malar prominences, and the smallness of hands and feet which mark the higher races of mankind, in contrast to the small cranium, prognathos and high cheek bones of the apes and lowest human types as seen in the aborigines of the Australian bush. As an instance of disease in man resulting from the arrest of the retarding action of the internal secretion of the pituitary gland, mention was made of the hypertrophic overgrowth of bone and soft structures, so well known in acromegaly.

Attention was directed to the development of the labia majora as a human characteristic attributable to special hormones of the thyroid gland, and stated to be absent in apes and insignificant in female negroes.

In addition to the above-mentioned somatic changes, brought about in the course of evolution of man by the agency of the endocrine organs, these glands have also exercised an influence on the germ-plasm. As instance was given the retarding effect pertaining to the secretion of the pineal body, on the development of the male and female genital structures, which has resulted in an important delay of sexual function, particularly in the higher races of man, to a much later period than is found in the lower mammalia. The abeyance of this factor might, it was suggested, account for the comparatively early sexual development in the lower races of mankind—for example, the negro—and in part explain their racial inferiority.

Professor Bolk also attributed sexual precocity, a condition more often met with in females than males, to the absence of the retarding effect of the special hormone of the pineal body, and as an example quoted a case of pregnancy in a girl aged 7 years. Suggestions of considerable interest were offered as to the gradual influence of change of diet on man's evolution. The increasing amounts of animal food in place of a purely vegetable and fruitarian regimen were regarded as possible potent factors in the high cerebral functions attained by the human race.

The chairman, Professor G. ELLIOT SMITH, in proposing a cordial vote of thanks to the lecturer for his admirable address, commented on the great value of his studies. His own opinion, he said, was that the large size of the human brain could not be explained by assuming that it was due to the perpetuation of the proportion of the large brain to a relatively small body of an earlier stage of development, for it represented an active growth and elaboration, the fundamental factor in the evolution of man. Dr. T. R. ELLIOTT had shown that this marked growth of the cerebrum was associated, in the human full-time foetus, with a striking modification in the structure of the suprarenal glands. He therefore tentatively suggested that this change might disturb the equilibrium of the endocrine glands, and prove the real mechanism whereby the great development of brain was itself responsible for restraining the full emergence of the simian traits of man's ancestor, rather than that this development should be due, as Professor Bolk had attributed, to the influence of change in man's diet.

British Medical Journal.

SATURDAY, JUNE 4TH, 1921.

MEDICINE A SCIENCE.

THE appearance of the second volume of *Studies in the History and Method of Science*,¹ edited by Dr. Charles Singer for the Oxford Press—a periodical or series of volumes which seems likely to become one of the chief mediums for the publication of essays in this department of knowledge—will move some readers to ask for a definition of science. In his preface to this volume Dr. Singer gives none, but in that to the first volume Sir William Osler, though he equally gave no definition, laid it down that the true and lawful goal of the sciences is the acquisition of new powers by new discoveries. It will be noted that Osler used the word in the plural. Sir E. Ray Lankester has recently quoted in more than one place Clifford's definition, if it may be so called, in which it was used in the singular: "The subject of science is the human universe; that is to say, everything that is, or has been, or may be, related to man." This is so wide as not to be very helpful, and, looking round for something more precise, Sir Ray Lankester suggests that the history of the word gives the explanation of its correct use at the present day. He points out that the French Académie des Sciences, founded in the middle of the seventeenth century, recognized various branches of knowledge; in doing so it did not go any further than Roger Bacon, of the thirteenth century, who recognized many sciences, by which term, however, he meant only a department of knowledge. It would seem that, as has happened in the history of many other words, the meaning attached to the term has been gradually and insensibly limited. The *New English Dictionary* recognizes that the word "science" in modern use is often treated as synonymous with natural and physical science, and thus restricted to those branches of study that relate to the phenomena of the material universe and their laws, sometimes with the implied exclusion of pure mathematics. It also recognizes that in a more general but still restricted sense it means a branch of study which is concerned with a connected body of demonstrated truths or with observed facts systematically classified and more or less colligated by being brought under general laws, and which includes trustworthy methods for the discovery of new truth within its own domain. Sir E. Ray Lankester's illustration rather confirms this view, for he says that the Académie des Sciences recognized various branches of knowledge as sciences, and that "very soon investigations made according to the rules laid down by those engaged in the building up of these 'sciences,' for the purpose of testing the soundness of conclusions and the systematic accurate application of those rules, were called 'scientific,' and the investigations so made and the resulting body of knowledge were called 'science.' The French Academy and the learned world generally definitely applied the word 'science' to all knowledge established 'scientifically,' that is, by the use of the scientific method." "In English speaking countries," he continued, "philosophers and the so-called 'men of science,'

have more and more definitely insisted on the importance of the 'scientific' method and the limitation of the word 'science' to knowledge tested and brought into order by that method."

All this is not logomachy, mere word-splitting; it is of great importance to medicine at this time, and has a very direct bearing on Sir James Mackenzie's address published elsewhere in this issue. It is a very long address, but the time given to its perusal will seem short, for it is well constructed and written and shows the direction in which the mind of one of the most striking personalities of the medicine of our time is working. Many people during the last generation have got out of the way of looking on medicine as itself a science; we have allowed it to be regarded as no more than a technical occupation, drawing information from various sciences, but not in its own methods and material worthy to be reckoned a science. So widely has this opinion come to be entertained that it is even adopted and applied by the Inland Revenue! Sir James Mackenzie does not mention the doctrine in so many words, but all through his address he is in effect challenging it. He is directly concerned with rebuking us for not giving sufficient attention to prognosis; but to make his point about this he has to show that medicine does in fact use the scientific method, and that its study, in common with that of other sciences, is conducted by way of investigations made according to certain rules recognized by all men of science as appropriate for testing the soundness of conclusions. It fulfils also the further requirement demanded of a department of knowledge claiming the status of a science, in that it is concerned with a connected body of demonstrated truths and observed facts colligated—though, it is true, to a very inadequate extent—under general laws and possessing trustworthy methods for the discovery of new truths within its own domain.

Medicine is concerned both with truths that can be demonstrated by experiment and with facts that can be established by observation; the relation of its two parts is very much that of physics to astronomy; but while the fame of astronomy has been continually increasing in the ears of all men, the observational part of medicine has rather lost credit. Sir James Mackenzie in his zeal for it may seem here and there a little in danger of depreciating the experimental side, but there is small chance of any harm befalling.

It is, we believe, true that he is to some extent preaching to the converted, and that the physiologists, the pharmacologists, the pathologists, perhaps even the bacteriologists, are becoming alive to the true situation; they have begun more clearly to perceive that not only does medicine want their facts, but that they must understand the nature of the problems and difficulties of medicine, and must, in order to enjoy to the full the stimulus it can give to their own work, study its methods "for the discovery of new truths within its own domain." Sir James Mackenzie lays stress on medicine's methods other than the experimental, and in particular on those which must be used for the study of prognosis. The power to foretell is the most difficult and usually one of the latest to be achieved by any science founded on observation. The address is very severe in its criticism of modern medicine for its neglect of the study of prognosis; there is truth in what he says of the skill of practitioners of an older generation in this respect. He would attribute it, we gather, in part to the fact that, having to depend more on their own unaided observations, their senses became more highly trained and they got to know their patients better. The account

¹ *Studies in the History and Method of Science*. Vol. ii. Edited by C. Singer. Oxford: The Clarendon Press. 1921. (Imp. 8vo, pp. 581; 78 figures, 55 plates. 48s. net.)

he gives of his own errors, labours, disappointments, and successes is at once fascinating, instructive, and encouraging. The whole address is a moving appeal to the general practitioner of medicine to take his share, which is the most important share, in advancing this most difficult department of medicine. It is an appeal by one who knows of what he speaks, one who has himself trodden the arduous path he bids others follow.

THE SURGICAL TREATMENT OF ANGINA PECTORIS.

JONNESCO's operation for the relief of angina pectoris¹ by excision of the sympathetic ganglia and interruption of centripetal paths from the aortic and cardiac plexuses, successful though it was in many respects, was not entirely satisfactory either from the physician's or the surgeon's point of view. No isolated piece of evidence could be. There is now another case to throw into the scales. In 1914 Rénon² had a female patient, 62 years of age, who was known to have had an aneurysm of the aorta since 1910; she was a woman of great energy, and she had suffered so severely from dyspnoea, thoracic and cervical pain, and headache that she declared herself desirous of operation, let the risks be what they might. The aneurysm, as revealed by *x* rays, was discrete, fusiform, situated in the ascending aorta, and surrounded by "considerable mediastinitis." Syphilis had been present but had been treated, and the Wassermann reaction was negative in 1914. Tuffier³ attacked the case *quâ* aneurysm—that is to say, he exposed the aorta by a transverse division of the sternum opposite the second intercostal space; found a fusiform aneurysm 2 in. long, beginning a finger-breadth above the origin of the vessel and of a circumference twice that of the normal aorta; he "isolated" it, and speaks of this as an easy matter, though one of the onlookers, Rénon, says it was the longest part of the operation. He then wound round and round the whole length of the aneurysm a long strip of fascia lata, applying two supernosed turns just below the bulge, in such a way as slightly to constrict the normal arterial lumen.

The result of the operation seemed rather more satisfactory to the surgeon who operated, and who speaks of her as "free from functional troubles for four years after," than to the physician who subsequently treated her for "a sensation of intrathoracic cramp," for "pains in the back and neck," for "slight bronchitis," and who mentions that suppuration occurred in the wound round a silver suture in the sternum, accompanied by "violent pains in the thorax." In 1919 the Wassermann reaction was found to be positive once more, and further treatment was given. The woman died in 1920 of recurrence of carcinoma of the uterus, for which she had undergone hysterectomy earlier in that year. No necropsy was permitted.

Rénon's conclusions amount to this: The feasibility of the operation has been established, for the patient's death six and a half years afterwards was not to be ascribed to the aneurysm; there was some amelioration of symptoms; the general state was better, and the pains, though severe at times, were much less frequent than before. He thinks the improvement due to "liberation of the mediastinitis by dissection of the aneurysm," which, however, was not permanently reduced in calibre by the intervention.

It may be remarked that in view of the known relation between the development of an aneurysm and progressive deterioration of the muscular and elastic elements in the wall, and the lack of resistance displayed by all other tissues, encirclement by a band of fascia promised no more than postponement of the evil day, and seems to have accomplished little.

However, when Rénon's paper was read at the Académie de Médecine, Delorme imported great interest into the discussion by pointing out that whilst dissecting or freeing the aneurysm, in the admitted presence of mediastinitis, Tuffier must incidentally have divided or removed the sympathetic plexuses on the anterior and left aspects of the aorta, and that this made it necessary to seek another explanation of the relief of the angina. He referred to Jonnesco's interruption of the reflex arc by dividing the centripetal fibres from the plexuses to the bulb, and reminded his audience also of the work of Leriche,⁴ who treated many war cases of ischaemic, or mixed ischaemic and neurotrophic "blighted" limbs by excising the sheath of the main artery. The surmise on which the operation is based is that by interrupting the sympathetic plexus about the vessel the surgeon secures dilatation of the vessels beyond, and recovery from palsy and trophic conditions, including matting of the tissues, supposed to be due to nerve injury.

This work of Leriche, Jaboulay, and Heitz, though it has found support from other surgeons,⁵ needs further confirmation, for it has even been denied that vascular nerves pass distally as a periarterial plexus at all, and direct supply of the arteries from nerve trunks has been demonstrated. Still, it is established that severe organic changes in the vessels may result from lesions of nerve trunks, and it is agreed that, in whatever way the fibres reach the walls of the aorta stimulation of their terminals therein is the starting point of anginal pain. Delorme pointed out that such a regional sympathectomy can have only a limited application, and that, so far as the progress of an aneurysm itself is concerned, it might even be a menace. On the other hand, as a variant of Jonnesco's method it may find a value in the relief of symptoms. Delorme also made reference to his work on "cardiolysis"—more accurately known as "pericardiolysis"—which has a somewhat similar basis to the precordial thoracostomy referred to recently by Dr. Blackhall-Morrison⁶ in our pages.

Rénon's case lends some support to the view that symptoms of cardio-vascular origin may be made amenable to surgery, and the report is welcome in that it affords still further witness to the turning of attention from the coagulation of contained blood to the condition of the containing walls in the treatment of aneurysm: it indicates a short step forwards towards the period foretold by Lauder Brunton, and indicated in greater detail by Vaquez,⁷ when "irremediable" conditions associated with heart and vascular disease shall successfully be brought within the realm of surgery. Not the least of the benefits accruing from war experience is a greatly increased familiarity of a large number of surgeons with intra-thoracic intervention on the widest scale, which justifies operations, hitherto perhaps foolhardy, in the presence of urgent and unsupportable symptoms.

The medical profession may well congratulate both Rénon and Tuffier on their courage and their success.

¹ BRITISH MEDICAL JOURNAL, 1920, vol. ii, p. 793.

² Rénon, *Bull. de l'Acad. de Méd.*, 3^e série, T. 85, No. 18, p. 528.

³ Tuffier, *Bull. et Mém. de la Soc. de Chir.*, January 28th, 1920, p. 163.

⁴ Leriche, *Lyon Chirurgical*, 1917, xiv, No. 4, July, p. 754.

⁵ Burrows, BRITISH MEDICAL JOURNAL, February 1st, 1918, p. 199; Stopford, *Lancet*, March 30th, 1918, p. 465.

⁶ BRITISH MEDICAL JOURNAL, 1920, ii, p. 840.

⁷ Vaquez, *Bull. de l'Acad. de Méd.*, October 7th, 1919, p. 157.

AN ANNUAL STOCK-TAKING.

ANYONE who finds himself in doubt as to the exact nature of the claim of the British Medical Association on the interest and support of the individual practitioner, to whatever section of the profession he may belong, will find his difficulties speedily resolved if he can attend the annual meeting at Newcastle. For the meeting considered as a whole affords at once an exposition of the aims of the Association in their totality and a practical commentary upon the way in which the several portions of the machinery of the Association work.

As will be seen from the programme of the Sections of the Annual Meeting, published in the SUPPLEMENT, the subjects selected for discussion at Newcastle include not a few of those by which the mind of the profession is at present most exercised. The retiring President, Sir Clifford Allbutt, will introduce in the Section of Medicine the discussion on visceral syphilis, especially of the central nervous and the cardio-vascular systems; and it will be observed that the special Section of Venereal Diseases intends to concern itself rather with therapeutics than polemics. The Section of Surgery will hold discussions on acute pleural empyema, on compound fracture of the thigh and leg, and on the diagnosis and treatment of injuries of the intestines, and will have the opportunity of witnessing demonstrations by its president, Professor Rutherford Morison, and others. The Section of Orthopaedics and Diseases in Children will also hold three discussions—one on the early diagnosis and treatment of anterior poliomyelitis, the second on blood diseases in children, and the third on tuberculosis of bone. The Section of Obstetrics and Gynaecology will discuss Caesarean section, and the neurasthenic element in midwifery and gynaecology, the latter subject being introduced jointly by an obstetrician and a neurologist. In the Section of Radiology and Electro-therapeutics (in the presidential chair of which Dr. Knox at short notice takes the place rendered vacant by the lamented death of Dr. Ironside Bruce) there will be a discussion on the changes induced in blood constituents by radiations—a subject which will be examined both from the experimental and clinical points of view.

Abstract consideration of the programme of the meeting, though a poor substitute for the practical experience of those who can take part in it, will be sufficient to show that the work of the Sections, the deliberations of the various conferences, the addresses and social features of the gathering, fall into place as component parts of a conception which touches at some point the interest of every member of the profession. Three aspects of the Annual Report of Council, which forms the chief basis of the discussions at the Representative Meeting, may be distinguished. All of them are essential to full appreciation of its significance. As will be seen from its perusal (it was published in the SUPPLEMENT of April 30th), it is, in the first place, a record of work accomplished, a summary of the practical achievements of the Association during twelve months. In the second place, it is a review of the collective experience of the profession throughout the Empire, an account of the environment which must inevitably play a determining part in the development of the practice of medicine. Finally, it contains, in the recommendations to be laid before the Representative Body, the outlines of a policy for the immediate future.

In its first aspect the contents of the report need little emphasis. They are such as the series of reports

which has preceded it have rendered familiar, and they will surprise only those who have accepted without investigation the old criticism that the British Medical Association is impotent or lethargic in fields other than those of science. As against such criticism it is shown how widespread is the Association's work in Australia, New Zealand, and South Africa, and how it is extending the sphere of its activity in the newly defined territories of Africa, in the Far East, and in the islands of the West Indies—successful in turn in the service of the individual member and of the sectional interest, in central action and in local. In definite increase of remuneration and improvement of conditions of practice, groups as diverse as the practitioners called to give evidence at courts-martial, the women practitioners in the service of the Metropolitan Asylums Board, and the practitioners in the Notts colliery area have alike profited, to quote at random from the full list, which, beyond equivocation or dispute, covers every field open to the qualified medical practitioner as such. The revision of the Draft Regulations under the Dangerous Drugs Act, 1920, balances these examples with an instance of action directly affecting almost every section in a greater or less degree. Such a record, besides its intrinsic interest, is a fitting background to the claim of the Association to represent the whole profession in a sense true of no other body. It should be kept in mind in any discussion of the negotiations with the Ministry of Health in respect of the constitution of a central committee representative of the whole profession, and suggests a new application of the old practical maxim, "What touches all should be approved of all," which underlies such negotiations.

As already pointed out, the significance of the report is by no means exhausted by a consideration of the successes achieved. It is essentially an epitome of professional experience during the period under review, and as such it records much work, the fruition of which is for the future. Such is the progress recorded in connexion with the model scheme for attendance on dependants of miners and other workmen, or the successful initiation of legislation for the security of tenure of public health officers. It includes also some instances of failure to attain objectives which seemed at one time well within reach. Such instances are instructive, for they illustrate two facts sometimes forgotten alike by critic and by partisan: first (as in the case of the postal medical officers) that the British Medical Association cannot act successfully for those members who cannot help themselves to the extent of expressing their views on matters touching their own interests; and second, that a period of peculiar difficulty will have to be met in the immediate future. More than once, as in the matter of superannuation for public health officers, the Council is obliged to report that the time is not opportune for further progress. This is simply to say that the medical profession cannot hope to escape the effects of prevailing economic conditions. Salaries and fees are not immune from the influences which have already brought about substantial reductions in the general level of wages, and threaten to retard if not to arrest the national works of reconstruction so hopefully undertaken after the armistice.

Amongst the other matters which call for particular attention, primarily from the section of the profession directly affected, but ultimately from all who are concerned in the general developments of the future, are the relations of certain sections with the Whitley Councils recently formed for the central (or national) and local government services; the position with

regard to the transfer of insurance practices; the ultimate form of the insurance record cards; and the lesson to be drawn from the Tasmanian Medical Act. Old foes with new faces are to be discerned here and elsewhere in the report.

So far, the report has been treated primarily as a record, and a few specific points selected for comment as an index to its general scope and character. For practical purposes, however, interest naturally centres upon the interpretation to be placed upon the experience recorded and the decisions which will determine the special direction of the Association's policy for the coming year. Apart from the recommendations touching the machinery of the Association, and the question of federation, which have been fully dealt with in recent leading articles, and the postponed discussion on the Reports of the Consultative Councils of the Ministry of Health, the main matters for debate (adopting the order in which they appear in the Report) are those presented under the headings of Medical Ethics, Medico-Political, and Hospitals.

Under the first heading comes a proposed definition of the attitude of the Association towards questions involving the principle of professional secrecy. The suggested solution lies in a sharp distinction between those cases in which the law as at present existing provides in the public interest for the communication of information obtained in the course of professional duties, and the case in which administrative action may tend to the enforcement of further exceptions to the rule of professional secrecy. It is recommended that the whole weight of the Association should be lent to initiate and support resistance to such encroachments. The second item of note is the proposed scheme for grading and remuneration of medical professors and teachers. A matter of sectional application in a limited sense, since the number of persons affected is numerically small, its importance to the teaching of medicine cannot be over-estimated. A decision is the more urgent because a general settlement of the problems of University teachers, so long overdue, might seriously prejudice the interests of the teachers of medicine, failing some authoritative exposition of their case for special consideration. Last come the two series of recommendations covering respectively the question of the future of the voluntary hospitals, and the utilization of the Poor Law infirmaries. Events of the last few months have brought problems of this order into prominence, and the urgency of forestalling either a national settlement or local experiments which may harden into local custom and finally secure establishment through national legislation, has apt illustration in the Bradford episode.

The whole hospital question, complicated as it is by the workings of what may perhaps be characterized as the "vested sentiment" of the community, demands the exercise of the highest qualities of statesmanship. The medical profession has to convince the public that its contribution to the settlement so impatiently demanded is determined in the long run by a correct interpretation of the public need, rather than by motives of professional self-interest. Only so can it hope to ensure that the adoption of some short cut to an immediate solution will not indefinitely postpone constructive measures of reform. A great step forward is marked by the measure of agreement amongst the honorary staffs of voluntary hospitals obtained through the medium of the Association and embodied in the recommendations contained in the first series. It is not sufficient, however, to deal with the readjustment of the old system. The recommendations on the voluntary

hospitals have to be supplemented by recommendations on the future utilization of the Poor Law infirmaries. Agreement upon the guiding principles to be accepted on this subject will be no unimportant contribution, alike to the needs of the profession and to the orderly development of the health services of the country.

INTERNATIONAL HEALTH WORK.

It has long been recognized that measures directed to the prevention of disease cannot achieve their full purpose unless they are international in character. This view was held by those engaged in the peace negotiations in Paris in the early months of 1919, and as a result Article XXIII of the Covenant of the League of Nations binds the members of the League to "endeavour to take steps in matters of international concern for the prevention and control of disease." The practical outcome of this conclusion is the establishment of a permanent International Health Section of the League of Nations and the formation of an Industrial Hygiene Department of the Labour Section of the League. This department is concerned with the "protection of the worker against sickness, disease, and injury arising out of his employment." With a view to assisting the International Labour Office in the solution of problems connected with industrial hygiene an advisory committee is now being formed which will include Government medical inspectors of factories and experts attached to organizations of employers and workers or to industrial establishments. International agreements have already been secured through the instrumentality of the Labour Office with regard to measures for the prevention of anthrax and in connexion with lead poisoning, and these two questions will be discussed at the October meeting of the International Labour Office. In this country provision was made in the Factory and Workshop Act, 1901, with respect to cases of anthrax or lead poisoning contracted in a factory or workshop. Notification of both diseases occurring under the circumstances named must be made by the medical practitioner in attendance to the chief inspector of factories at the Home Office, and the employer is required to give notice of the cases to the certifying surgeon and the local factory inspector. In those factories in which lead processes are carried on and where women or young persons are employed, suitable washing conveniences must be provided, meals must not be taken in rooms where lead is used, and mechanical means must be installed for carrying off the dust. Periodical examination by the certifying factory surgeon of workers in lead is included in the preventive measures in force. Regulations have been made with respect to factories and workshops in which infected hides or wool are handled. These include the provision of washing conveniences with a supply of soap, towels and nail-brushes, the compulsory washing of the hands before partaking of food, the non-employment of a worker who has an open sore or cut, and the provision of suitable fans for the extraction of dust. In carrying out its task of protecting the worker against disease arising out of his employment the International Labour Organization will receive material assistance from the pioneer work of the Home Office, initiated and carried out by Sir Arthur Whitelegge when he held the position of H.M. Chief Inspector of Factories; of his labours it is impossible to speak too highly.

THE EPIDEMIC OF UNREST.

At a meeting of the Society of Arts on May 25th Dr. C. M. Wilson read a paper on "Some effects of the war on industrial unrest." His remarks were for the most part a careful analysis of the present mood and temper of labour. To begin with, he distinguished the case of the

man who had seen active service from that of the man who had remained at home. The latter, if he had done so involuntarily, and had been a target of abuse, was filled with a sharp sense of injustice, and if he had avoided active service without any valid reason he was suffering from a loss of self-respect proportional to the good that was in him. In either event his mental state was morbid, making him much more difficult to deal with than the ex-soldier. In such a soil grievances flourished, and such a man became unduly eager to exhibit his valour in different directions. From this Dr. Wilson passed on to describe some of the causes that led to unrest in the trenches, such as the "cooking" of war news for home consumption and the decline in authority consequent upon the perception that the mental outfit for leadership was generally lacking. Men in the mass were now more critical than before the war, and were less inclined to believe what they heard and read. They had been prepared by the war for an appeal based on something higher than self-interest, and the opportunity had not been taken by employers. He regretted that the captains of industry had not generally followed the example of the officers of the old regular army in devoting themselves unselfishly to the needs of the men, and giving them that personal leadership which had proved its value in the field. The discussion on Dr. Wilson's paper was somewhat diffuse, but it was made interesting by Dr. Graham Little's testimony to the working man—all members of the medical profession, he said, who were privileged to come into contact with the working man had a very high opinion of him—and by Dr. Charles Buttar's footnote to Dr. Wilson's theme. Dr. Buttar contested the implication in the title of the paper; unrest was not confined to the industrial population, and he doubted whether it was caused by the war, for possibly the war itself was only a symptom of a larger unrest. To his mind the epidemic of unrest was due to the want of a satisfying object in life, to love of money, and the false pursuit of happiness. He saw no hope of happiness in many of the weird cults and beliefs which were taking the place of the ancient faiths; nor was true happiness necessarily to be found in rolling along high roads in luxurious cars; nor, again, was the smashing of the machinery of civilization in a crusade of labour against capital likely to bring about the millennium. He believed that salvation would only be found in a return to ideals similar to the old ideals—a faith for some, work for most, and a sense of duty for all. This sentiment drew the warmest applause of the evening.

TELL-TALE TREATMENT.

AMONG the kings of France one of the best known to readers of English literature is Louis XI. This is due to the genius of Scott, who, in his portrait of the King, drew a picture of mingled astuteness, cunning, cruelty, and superstition not easily to be forgotten. Attempts have been made to whitewash him, and no doubt by his successful efforts to curtail the power and independence of the greater feudal nobles he had a share in the unification of France. But Scott's view of his character is that generally accepted, and reflects the opinion of Louis's own time and of the majority of French historians. In a volume reviewed elsewhere in this issue Dr. Cabanès has come forward with a suggestion which may explain, if it does not excuse, some of the darkest traits in Louis's character. The suggestion was made in the course of some lectures on the light clinical medicine may throw on general history, and was given as an illustration of the doctrine *naturam morborum ostendunt curationes*—the method of treatment indicates the nature of the disease. Louis XI on one occasion wrote a letter to the Prior of Notre Dame de Salles at Bourges as follows: "Master Peter, my friend, I beseech you as earnestly as I can at once to pray to God and Our Lady of Salles for me that they may be pleased to send me a quartan fever, for I have

a disease of which the physicians say that I cannot be cured without having it; and when I shall have it I will straightway let you know." Voltaire had read the letter and was very scornful about it, but he did not read it with sufficient care. He says that the King asked to be granted quartan fever, which would be good for his health, and exclaims, "The impudent quackery of the doctors was as great as the stupidity of Louis XI and his stupidity equal to his tyranny." But Louis did not say that a quartan fever would be good for his health; he said that he had a disease which could not be cured unless he had a quartan fever; the only conclusion the statement justifies is that Louis had a disease worse than a quartan fever, and this Voltaire might have perceived had not his anxiety to find a stick with which to beat the doctors blunted his customary acumen. Dr. Cabanès recalls the observation attributed to Hippocrates and well known to mediaeval medical writers who founded themselves on him. It was thus stated by one of them, "if an epileptic is once seized with quartan fever he is better for the most part of his time." Dr. Cabanès's suggestion is that Louis suffered from epilepsy; if he did it would account for a good many things about him, his fits of moroseness, for instance, and his periods of seclusion. Dr. Cabanès can explain why the King addressed his request to the Prior of Notre Dame de Salles; it was because that sanctuary was much frequented by pilgrims from the ague-stricken district of Sologne where there is still much marsh land. In no other sanctuary, Louis might argue, would the way in which fevers were contracted be better understood or the supply larger. On another occasion Louis made inquiries about Notre Dame d'Embrun, a sanctuary with a reputation for the cure of epilepsy. Dr. Cabanès finds confirmation of his suggestion in other facts known about remedies taken by Louis, since among them were many deemed useful against the falling sickness; in this way the dark stories of how the King took baths of human blood may be accounted for, since to drink human blood was sovrain against epilepsy. Possibly the King had also some other disease; a contemporary affirmed that he had leprosy or something like it. In 1483 Louis sent an expedition at considerable cost to the Cape Verd Islands, the purpose of which has puzzled historians. One of these islands was it is said, visited by lepers in the hope of cure; the treatment consisted in rubbing the skin with the blood of tortoises, which were plentiful there, and eating the flesh and fat. Perhaps Louis had some chronic skin disease, or possibly he thought that tortoise blood might be better for epilepsy than human blood. Whatever we may think of this, Dr. Cabanès's first conjecture about quartan fever is a good illustration of his thesis.

A MEDICAL PRIME MINISTER.

M. EMILE COMBES, once Prime Minister of France, died on May 25th, at the age of 86, at Pons, a small town on the road between Cognac and Bordeaux, where at one time he had practised medicine. He was a southerner and was born of poor parents in the department of the Tarn. He was educated at Roman Catholic seminaries, and as a young man taught in Roman Catholic colleges at Nîmes and Pons. At the age of 25 he wrote a book on the psychology of St. Thomas Aquinas, but his opinions underwent a revolution, and two years later, at the age of 27, he determined to begin the study of medicine in Paris; he took the degree of M.D. in 1868 and settled in practice in Pons. The first public office to which he was elected was that of Mayor of Pons; in 1879 he was elected a member of the Conseil Général of the Department of Charente Inférieure, a body possessing powers in some directions greater and in others smaller than a county council in England, but exercising more political influence. Combes was defeated when he attempted to enter the Chamber of Deputies in 1881, and it was one of the peculiarities of his career that he never

belonged to that body. He was elected to the Senate in 1835, became its vice-president in 1894, and remained a member of it until the end of his life. His first portfolio was that of Education and Public Worship in 1895, and though the ministry only remained in office for six months Combes gave sufficient indication of his anticlerical disposition to alarm the moderate parties. His views, however, were popular, and his influence grew steadily during the ministry of Waldeck-Rousseau (1899-1902); in June, 1902, he became Prime Minister. Under Waldeck-Rousseau a law had been passed requiring the religious orders to obtain from the State authorization to continue their work. Combes, with the support of the parliamentary party which went by the name of the Bloc, broke off relations with the Vatican and withdrew from the religious orders the right to teach in France; he was no doubt, for all practical purposes, justified in saying that the concordat established by Napoleon was then brought to an end, though it was left to his successor to complete the separation of the churches from the State. While engaged in this bitter controversy at home, in his conduct of foreign affairs M. Combes sought to make friends for France by pursuing a policy of conciliation, and his hope was to find in arbitration a safeguard against war. He entered into arbitration agreements with Great Britain, Italy, Holland, Norway, Sweden, and Spain. After the resignation of his ministry in 1905 he seemed to retire, but continued to play a considerable part behind the scenes and made and unmade more than one ministry. During the war he subordinated any personal ambitions he may have retained to the common good, and was a member of M. Briand's Cabinet (1915-16). Thus, of the Prime Ministers of France in this century, two of the most conspicuous, Combes and Clemenceau, were members of the medical profession. The qualities which brought the latter to power are easy to comprehend, but it is not so easy for a foreigner to understand the sources of the influence Combes exercised on the course of French politics. It was unquestionably great, and for nearly twenty years he was probably the most prominent of French politicians. His success is the more surprising since when he entered on a political career he was much older than most men who attain success in it; he was then 50 and had spent some twenty years in the arduous work of a doctor in a country district. His influence, it would seem, was in large measure due to a certain honesty and simplicity of character which he retained to the end.

IMMUNITY AND INDUSTRIAL DISEASE.

BEFORE the Royal Society of Arts, on May 30th, Sir Kenneth Goadby read a paper on immunity and industrial disease. Very little, he said, was known of individual susceptibility and immunity to many of the corrosive substances used in manufacture; thus, in the dyeing of yarn with chrome, certain workers suffered from ulceration after a very short time, while others had a slight but recurrent dermatitis which only after long exposure degenerated into deep and penetrating ulcers. In this instance natural immunity and susceptibility played leading parts in the appearance of the disease. Individual susceptibility explained many curious forms of ulceration seen in such trades as confectioners, drug manufacturers, felt hat makers, and the fur trade. Diseases arising from dust, fumes, and vapour comprised a large section of industrial disease, and amongst the air-borne diseases lead contributed by far the largest number of cases. The high incidence of lead poisoning in the painting trades was difficult to understand, as lead-dust inhalation was the chief source of lead poisoning, and except in dry rubbing down the painter is not exposed to lead dust. An acute attack of abdominal pain often followed breathing the air of newly painted rooms; it was due, the lecturer believed, to turpentine poisoning. Arterio-sclerosis, resulting in increased blood pressure, was admitted to be a common disease among

painters; a comparison of the blood pressure of painters working with leadless paint for some years with the blood pressure of workers engaged in the manufacture of white lead showed that the latter as a whole had a much lower blood pressure, according to their age group or according to the period for which they had worked, than painters. The painter's occupation, therefore, apparently entailed some risk contributing to high blood pressure not present amongst the white lead workers; this might be associated with the vehicle used for the paint, the chief constituent of which was turpentine and its substitutes. While ailments common to the whole population might be augmented by industrial disease, it was equally true that minor affections predisposed to industrial diseases, especially the large category of small but persistent microbial poisons emanating from septic mouths, unhealthy tonsils, persistent catarrh, and long-continued constipation, all and each of which sooner or later diminished the power of the blood to resist other poisons. The fact that individual susceptibility and immunity were factors in determining much of the special disease in dangerous trades suggested certain general blood tests, whereby susceptible persons could be eliminated from an occupation inimical to their well-being. The blood tests were simple, and the estimation of blood pressure an ordinary routine of medical practice. A selection of workers for especially dangerous processes, following the general indications outlined—for instance, alterations in blood pressure and the white cells of the blood after a short exposure to the dangerous trade influences—would, the lecturer urged, not only reduce the incidence of industrial poisoning in many occupations, but might even render safe some trades now regarded as dangerous. The great proportion of the work in dangerous trades was non-skilled, so that no hardship would arise from an elimination of susceptibles. Even the painter served an apprenticeship, and during the earlier time was a labourer; two special examinations, one at three and one after six months' employment, would be sufficient to eliminate susceptibles. The general principle of selection for a given occupation was carried out to some extent in many walks of life, and it did not seem unreasonable to extend the method. A trade union organization charged with the general improvement of the health of its members would have the whole-hearted co-operation of the public at large and command universal attention.

PEARL PATHOLOGY.

As there is a very general but erroneous impression that a pearl is formed around a parasite, as the process is, in fact, pathological, and as the production of the Japanese artificially induced "Mikimoto" pearl is a curious example of minute plastic surgery, the following notes, founded on a paper published last week in *Nature*, by Dr. H. Lyster Jameson, who announced Mikimoto's first successes to the Dundee meeting of the British Association in 1912, possess some medical interest. It is first to be noted that certain small pearls which have no commercial value are produced in *Mytilus* by the specific stimulus of a trematode. How pearls such as those produced by the Ceylon pearl oyster originate has not been ascertained. Only in a few instances are foreign bodies, such as radiolarian shells, sponge spicules or quartz grains, found at the centre of the pearl. Usually the nucleus is composed of a kind of shell substance of pathological origin, identical with that with which the oyster repairs an injury to its shell. The free surface of the mantle of an oyster is formed of cylindrical ciliated epithelial cells; the shell is produced by the outer shell-secreting epidermis, consisting of cubical cells. If a foreign body, such as a piece of mother-of-pearl, is inserted between the shell-secreting epidermis and the shell, shell substance is laid down, forming what is called a blister, more or less hemispherical, projecting from the shell and continuous with

its inner surface. By this method the Chinese induce fresh-water mussels to coat tiny images of Buddha with mother-of-pearl, and a similar experiment was carried out by Linnaeus in the eighteenth century. The coated images are merely curiosities and the commercial value of the blistered pearls is low. Mikimoto has got far beyond this; the natural pearl is formed in an epithelial sac, which has somehow been formed in the parenchyma of the mantle or muscle. It is this epithelial sac that Mikimoto imitates, a process demanding the most delicate and skilful manipulation. The shell of a pearl oyster is removed and a bead of nacre or other suitable nucleus is laid down on the outer, shell-secreting, epidermis of the mantle. The epidermis is then dissected off, and wrapped round the nucleus to form a sac; the neck of the sac is then ligatured. This sac is next transplanted into a second oyster and embedded in the parenchyma of its mantle. The ligature is then removed, astringents applied to the wound, and this second oyster with its grafted pearl sac containing the mother-of-pearl bead, is returned to the sea, where it remains for several years—seven or more—until a coating of pearl substance of sufficient thickness is secreted around the introduced bead. A pearl can be formed only in a pearl sac, which, as has been explained, is a closed cavity lined by nacre-secreting epithelium. Apparently a pearl sac must owe its origin to a traumatism of some kind, unless we suppose that it may be a congenital deformity.

VITAMIN.

RECENTLY in a note upon the spelling of chemical terms (April 9th, p. 539), it was stated that the rule of the Chemical Society must be interpreted to require the spelling of vitamin without the terminal "e." A correspondent now inquires as to the pronunciation. We had supposed that there could be no doubt that the first syllable was long and the "i" in it produced in the English manner (according to the analogy of "vital"). On the question of length we have consulted Sir Clifford Allbutt, who has no doubt that the first syllable is long—vita. "I have," he says, "looked in such lexicons as are at hand, to see if at any time the length was in varied use, but find no authority for any short use. No doubt in coining the word vitamin vita was used in no antiquarian, but the ordinary sense: 'tenues sine corpore vitæ' (*Aenid.*, vi, 292)." We have heard the word pronounced with the "i" as "ee" in Continental fashion, but we believe this to be unusual. The word was coined by Casimir Funk, who thought these bodies contained amines and even gave a formula for them. As he regarded them as necessary to life he called them "vitamines." They are, however, not amines. The term used by Professor Gowland Hopkins, "accessory food factors," which is descriptive and non-committal, would be the best hitherto suggested were it not so long. Professor Armstrong proposed the word "advitant," indicating simply that the substance is necessary to life; but it is an awkward and ugly word. Dr. John Brown suggested "vitoids" (an awkward word) and also "biogen," which, by suggesting the analogy of fibrinogen and so on, seems to us bad. Probably "vitamin" is too well established to be displaced, and we notice that Colonel McCarrison, in his book just published, to which he gives the title, *Studies in Deficiency Disease*, speaks throughout of "vitamins."

SURPLUS MEDICAL STORES.

THE Surplus Government Property Disposal Board has lately arranged with the Joint Council of the Order of St. John and the British Red Cross Society to offer surplus army medical stores and hospital equipment for sale on special terms to hospitals and kindred institutions. It is hoped by this means to aid the voluntary hospitals in meeting the urgent economic problems that now face them, and at the same time to benefit the

taxpayer. The stores have been brought from the various collecting posts throughout the country into one large dépôt at Shepherds Bush, where they have been examined and graded into two categories—the new and the used or partly worn—the latter having been overhauled, adjusted, and renovated. The total value of the stores, now collected in a vast hangar near Wood Lane Station, is about one million pounds. They include a large amount of dental and x-ray appliances, half a million surgical instruments, a great deal of operating-room furniture, and about fifty tons of drugs. The arrangements have been carried out under the direction of Sir Howard Frank, the new chairman of the Disposals Board, and Sir Napier Burnett, M.D., chief executive officer to the Joint Council. A catalogue has been printed and every item in the sale list is now being priced at a level which it is hoped will offer a strong inducement to the hospitals and nursing institutions of the country to replenish and renew their equipment. The dépôt will be open for the inspection of the goods on June 14th, and will remain open each day, except Saturdays, until further notice. Invitations have been sent to hospital authorities to visit the dépôt, and no one will be admitted to it without an official permit from the Hospital Service Department, 19, Berkeley Street, W.1. Permits will be issued to 100 hospitals each day, but no sales will be effected until all the hospitals have had an equal opportunity of viewing the goods and making their choice.

LANGLEY PRIZE IN TROPICAL MEDICINE.

A PRIZE has been instituted at the London School of Tropical Medicine in memory of the late Dr. W. H. Langley, C.M.G., Principal Medical Officer of Southern Nigeria, who died in 1912. The fund was raised principally on the coast. The war intervened and all the papers and subscription lists went down in the ss. *Umgeni*, when Dr. Lynch Burgess, of the West African Medical Service, who was treasurer of the fund, lost his life. Dr. Thomas Hood, C.M.G., and Major Gerald Bell, two of those originally connected with the movement, have made the arrangements for setting up the memorial in connexion with the London School of Tropical Medicine. The prize (about £30) is to be awarded triennially and is open to competition among officers of the West African Medical Staff, whether on the active or retired list. The award will be made in respect of the best paper written on one of the following subjects: (a) Tropical medicine or surgery, (b) tropical hygiene and sanitation, (c) tropical entomology and parasitology. The first award will be made in 1924. Papers should be delivered to the Secretary, Seamen's Hospital Society, Greenwich, S.E., on or before October 1st, 1924.

THE ANNUAL MEETING AT NEWCASTLE.

THE Honorary Local Secretaries of the forthcoming Annual Meeting at Newcastle-on-Tyne are becoming anxious to know how many members they may expect, in order that arrangements may be made for the accommodation of visitors. It is particularly requested that early use may be made of the form of notification of attendance, printed in this week's SUPPLEMENT, at p. 217. Detailed information about accommodation in hotels, hostels, and lodgings in Newcastle and neighbourhood was given in the SUPPLEMENTS of May 7th and May 21st.

DR. F. L. GOLLA will deliver the Croonian Lectures before the Royal College of Physicians, London, on Tuesdays and Thursdays, June 9th, 14th, 16th, 21st, at 5 o'clock. The subject is "The objective study of neurosis."

WE regret to record the death of Professor Giorgio Ballerini, director of the school of obstetrics at Perugia, who served with distinction in the Italian army during the war.

Medical Notes in Parliament.

[FROM OUR PARLIAMENTARY CORRESPONDENT.]

Washington Labour Convention.

AN animated debate took place on May 27th on a motion by Mr. Barnes that the conventions adopted at the International Labour Conference in Washington under the League of Nations should be submitted to Parliament.

Mr. Barnes's case was that the "competent authority" to which the conventions were to be referred in each country wherein a Parliament existed was Parliament, and that ministers had no right to decide whether or not ratification should take place. It appeared that three departments were concerned—the Home Office, the Ministry of Labour, and the Ministry of Health. The Home Office had given effect to three conventions touching the nightwork of women, the nightwork of young persons, and the age of admission of children to industrial employment. By the Women and Young Persons (Employment in Lead Processes) Act, 1920, effect was given to the recommendations as to lead poisoning. To the other three recommendations with which the Home Office had to deal—anthrax, Government health service, and the prohibition of white phosphorus matches—effect was already given. The Ministry of Labour and the Ministry of Health were interested in the remaining conventions—eight hours labour and maternity. Mr. Barnes explained that he did not vote for the last named recommendation, but he held, nevertheless, that all these conventions should be considered by Parliament.

Dr. Macnamara met the motion with an amendment asking the House to declare that in existing circumstances it was inexpedient to give legislative effect to the convention on hours of labour. He held (with the support of the Attorney-General) that the "competent authority" to which all the conventions were to be referred to decide whether they should be ratified or not was the Government; but did not rest his defence on that ground. He suggested, in fact, that the eight hours labour issue could be discussed on his amendment, and said that the Government objection to the convention was that it cut across agreements made with trade unions. In regard to the refusal of the Government to ratify the maternity convention he quoted a reply made by Dr. Addison as Minister of Health, when the matter was raised on March 22nd. Dr. Addison then said that the proposals of the Washington Convention were that provision should be made for the six weeks preceding and the six weeks following confinement in employed women. This country had the Insurance Act, which provided maternity benefit for women who were themselves workers or the wives of employed contributors. Parallel with that, and administered by local authorities, was a system for giving assistance and advice in connexion with maternity and child welfare generally. These recommendations cut right across the whole of that system, which has been gradually built up in this country far in advance of any other country. Dr. Addison further said: "Our system provides that not only the women employed, but the women who are the wives of employed contributors, although they themselves are not employed, shall also benefit. . . . These recommendations apply to about one-ninth of the married women of a particular class in this country, and to one-ninth only. But we have done something for the remaining eight-ninths."

Viscountess Astor thought this answer unsatisfactory and urged that this convention should be brought before Parliament. The object of the Convention was to protect women who through the illness of their husbands or through their husbands not getting sufficient wage were forced into industry and had to work up to the very last hour before their confinement, and had to get back perhaps in a week's time. It had been suggested that if the recommendation were adopted many women would go into industry before childbirth so as to get benefit. She did not believe they would do that if they could help it. She asked that the Minister of Health should consult a committee representative of women's societies.

Dr. Macnamara's amendment was carried by 109 votes to 69, but on further appeal he promised to give an opportunity for discussion of the reasons why the Government had declined to ratify the Maternity Convention or the Hours of Labour Convention; and that this opportunity should be afforded before the period for ratification expired, which he believed was in July.

Ministry of Pensions Medical Officers.—In reply to Lieut.-Colonel Croft, on May 30th, Mr. Macpherson said that, with the approval of the Treasury and after consultation with the Ministry of Health, the Ministry of Pensions had given a four years' contract, terminating on March 31st, 1925, to a number of full-time salaried medical officers whose employment had previously been subject to one month's notice. Lieut.-Colonel Croft asked whether the Minister of Pensions would undertake that the services of those doctors at present employed under the Ministry of Pensions who sacrificed their practices to join the army and navy at the outbreak of the war and were on active service, and are now dependent solely on their salaries, would be retained at the Pensions Ministry in preference to those who were already drawing big pensions in addition to their salaries and those who had never served abroad. Mr. Macpherson said that practically the whole of the full-time medical officers of the Ministry served during the late war, and other things being equal, preference for retention would continue to be given to medical officers who saw active service over medical officers in the same class who did not so serve.

Public Health Officers' Bill.

This measure, which was introduced by Sir Philip Magnus, and recently obtained its second reading, was taken in Grand Committee of the House of Commons on May 26th.

Its object is to give to full time medical officers of health of local authorities and sanitary inspectors, security in tenure as is enjoyed by Poor-law medical officers, metropolitan medical officers of health, and medical officers appointed by county councils. The term sanitary inspector covers "inspectors of nuisances," and is henceforth to be used in all cases. Sir Philip Magnus stated that an Order in Council already provided that medical officers appointed in the future should be protected from dismissal except with the Minister's sanction. Mr. Myers, for the Labour Party, supported the measure as in the public interest, namely, to strengthen medical officers in the performance of their duty by enabling them to discharge it without fear. He referred to the difficulty which otherwise was sometimes experienced in condemning an insanitary area. A new clause was inserted, at the instance of Sir Kingsley Wood, for the Government to lay down that the bill should apply to medical officers and inspectors, whether appointed before or after the Act, but not to those cases where no grant was received from the Government. It was stated that these ruled out only about twenty-five authorities, mostly large, and in these the independence of the officers is practically secured by the size of the authorities. The bill was ordered to be reported to the House of Commons.

University and College Grants.—Mr. Hopkins asked, on May 26th, what were the principles and regulations under which the University Grants Committee was to recommend the distribution of the Parliamentary Grants recently approved by Parliament for the coming quinquennium; was it an implied condition in the allocation of financial aid to University Colleges from the extra grant voted by Parliament, that they should obtain equal financial assistance from local authorities; and was this principle also to be applied to grants made for the formation of clinical units in the hospitals; had the principle of giving building grants to University Colleges been authorized, and if so, what were the principles in which such grants were to be made; and was it intended to supply Government funds to raise the salaries of the more important professors in University Colleges to the same figure—namely, £2,000 per annum, as had been fixed as the salaries of the professors of the newly instituted clinical units in the hospitals. Mr. Young, Financial Secretary to the Treasury, replied that the general principles on which the University Grants Committee based their recommendations for the allocation of grants, were set out in the Report of the Committee dated February 3rd, 1921, and in the letter to Sir William McCormick printed as an appendix to the Report. Great importance was attached to the amount of support provided from local sources in calculating the grants payable to the different institutions, but except in the case of the University of Wales, there was no undertaking by the Government to make grants on the basis of pound per pound in respect of rate aid. The Committee were authorized to recommend capital grants for sites, buildings, and permanent equipment, if the funds at its disposition allowed, but no such recommendations had yet been made. The responsibility of fixing the salaries of the teaching staffs rested with the authorities of each institution.

Tuberculosis Treatment.—Sir A. Mond, on an inquiry by Mr. Ronald McNeill, denied that regulations had recently been made with respect to the institutional and other treatment of tuberculosis, by county and borough councils.

Universities (Scotland) Bill.—Mr. W. Graham asked, on May 26th, whether the text of the Universities (Scotland) Bill, 1921, had been supplied to education and other bodies in Scotland; whether the bill had yet been presented to the House of Commons; and when Scottish members would be supplied with copies of it. The Secretary for Scotland replied that a Universities (Scotland) Bill was submitted to him with the approval of the University Courts of the four Scottish universities, but he was not aware if the bill in that form was considered by any education bodies other than the University Courts. He was considering the possibility of introducing a Universities Bill; that he had in view was substantially the measure of the University Courts. He feared that it would not be possible to make progress with such a bill this session, but he hoped that he might be able to introduce it so that its provisions might be considered by persons interested.

Milk Prices.—Mr. Baldwin, in answer to Colonel Newman on May 26th, said that the producers' average price for milk in May, 1920, was 1s. 3d. a gallon; in May, 1921, it was 1s. 2d. a gallon. The average retail price per quart in May of both years was 8d. A comparison of the figures was, however, fallacious for three reasons: (1) The milk trade was this year fixing a single retail price for the whole summer, and the May figures could not accordingly be taken as a basic standard of comparison; (2) wages had been increased in pursuance of the Trade Board award; and (3) there was a considerably increased loss on the portion of the supply converted into cheese.

Use of White Lead in Paints.—Lieut.-Colonel Sir J. Gilmour (for the First Commissioner of Works) stated, on May 30th, in answer to Major M. Wood, that the practice of the Office of Works for the last fourteen years had been to use paints with a non-poisonous zinc base instead of a white lead base, and all contracts involving painting stipulated that no paint must contain more than 5 per cent. of soluble lead.



FIG 1.—Roman wall looking east towards Housesteads.

EIGHTY-NINTH ANNUAL MEETING
of the
British Medical Association,
NEWCASTLE-UPON-TYNE, 1921.

LOCAL ANTIQUITIES.

THE GREAT WALL.

SOME of the most interesting relics of the Roman occupation of Britain are to be seen in Northumberland, and they all centre round the system of fortifications known as the Great Wall. It is the stone wall and its supporting stations of which so much remains, but the system included an earth wall known as the Vallum, and other earthworks, military roads with bridges, mile-castles, turrets, stations, and townships which flourished under the protection of the great barrier and its garrisons. Remains which have been abundantly found in the district not only show the great military strength of this outpost of the Roman Empire, but indicate that at times the settled quietude of the exiles from sunny climes encouraged the establishment of refinement in living and the cultivation of the gentler arts. Kipling, in *Puck of Pook's Hill*, has given a vivid picture of what life on the Wall may have been, but the pilgrim, as he contemplates the vast ruins of man's pertinacity, grass-grown and solitary, must be impressed with the mutability of human affairs.

Cities and Thrones and Powers
Stand, in Time's eye,
Almost as long as flowers,
Which daily die.

The Great Wall stretched from Wallsend, near the mouth of the Tyne, to Bowness on the Solway, a distance of seventy-four miles. It represents, not the Roman frontier in the North, nor a fence to keep out the Picts and Scots, but a series of military posts linked together so as to enable the garrisons to assemble quickly at any one point either for attack or defence.

The outstanding feature of the Wall as a whole is its direct route across country, only deviating from the straight to take advantage of some strategic point, and

never fearing to skirt a veritable precipice or to dip straight into the deepest valley (Fig. 1).

The dimensions are estimated to have been 20 feet high, with a width of about 8 feet; while the fosse to the north was 30 to 40 feet wide and 12 to 15 feet deep. At no place is the ruined wall now more than 8½ feet high, and for the most part only a few courses remain, but in certain places the fosse has been better preserved, and is still probably of its ancient dimensions.

The structures that were formed for the accommodation of the soldiery who manned the wall consisted of stationary camps, mile-castles, and turrets. About every four miles there was a station. These were military cities suited for the accommodation of the chief who commanded the district and the garrison under him. These stations are quadrilateral in form, and consist of a strong wall with fortified gates; the wall encloses an area of from three to five acres, on which the military offices, public offices, and houses were erected. Their position was often elevated and exposed, and some of them, as that at Housesteads, are in the wildest part of Northumberland.

In addition to the stations, Castella or mile-castles were distributed all along the wall at this distance from one another. They measured about 60 ft. by 50 ft., and were merely for the accommodation and protection of the soldiery. The turrets were little more than stone sentry boxes recessed into the great wall; three or four were placed equidistant between each mile-castle.

Visitors to Newcastle should take the opportunity of visiting one or more of the camps which are within easy reach of the city, for here can be pictured something of the life of the men who garrisoned the wall.

One of the largest and best preserved of these camps is at Clunnum or Chesters, about eighteen miles by the direct road from Newcastle (station, Humshaugh, North British Railway). Here one may see the remains of the bridge across the Tyne, a Roman villa, and a museum of Roman antiquities, which is one of the best of its kind in the country.

Of the situation the Rev. John Hodgson has said: "The

¹ Previous articles on the history, institutions, and industries of Newcastle have appeared in the BRITISH MEDICAL JOURNAL of December 11th, 1920, p. 902; March 12th, 1921 p. 391; and April 16th, 1921, p. 577.



FIG. 2.—Roman street at Chesters.

Astures, in exchanging the sunny valleys of Spain for the banks of the Tawny Tyne, might find the climate in their new situation worse, but a lovelier spot than Cilnnum all the Asturias could not give them."

The camp is situated on the banks of the North Tyne. It is rectangular in shape, but with six gateways instead of the usual four. The Wall comes up to the eastern gateway and passes on from the western side of the camp. The gateways here still show ruts worn by chariot wheels

statuary, vases, gems, coins, rings, and so forth, which have been found during excavations on various parts of the Wall.

The camp at Housesteads (Borricivus), five miles further on, contains a temple dedicated to Mithras, the Sun-God of Persia. About two miles to the south, at Chesterholm, a Roman milestone is to be seen still proudly standing upon the line of the Stauegate (Fig. 4).

The largest station is at Burdoswald, near Gilsland in



FIG. 3.—Abutment of the Roman bridge at Chesters.

and the tramp of feet passing to and fro; the heating chambers when opened out in 1843 still contained soot, and the bath was coated with red cement. The marketplace, with its public buildings, the treasure house and the Governor's residence, give the visitor plenty of material for his imagination to build upon (Fig. 2).

A hundred yards away is the river with the remains of the Roman bridge which spanned it at this point, and which Dr. Collingwood Bruce considered the most remarkable feature on the whole line of the wall (Fig. 3). In the museum are preserved numerous altars, inscribed stones,

Cumberland, on the main line between Newcastle and Carlisle.

It is impossible in so short a space to do anything more than briefly mention some of the most interesting features of the Wall. The visitor must see something, no matter how little, to realize the magnitude and the grandeur of this work. An excursion is being arranged in connexion with the meeting, to visit Chesters and the Wall in the neighbourhood, and no one who is not already familiar with this vast monument of Roman greatness should miss the opportunity.

PLACES OF INTEREST IN THE
NEIGHBOURHOOD.

Excursions are being arranged to visit some of the following places of interest in the neighbourhood of Newcastle-on-Tyne, all of which have taken a large share in the making of history in the "north countree."

Alnwick, the old county town of Northumberland and the seat of the Duke of Northumberland, lies thirty miles north of Newcastle: now a peaceful border town, but once a disastrous spot to the Kings of Scotland. The Abbey and the Castle contain much of interest. The bridge over the Alne with the Percy Lion with outstretched tail is a conspicuous feature not easily forgotten.

Morpeth, fourteen miles north of Newcastle, is a picturesque market town dating back to a remote period. The Castle, which was built shortly after the Conquest, stands on an eminence just above the main road leading into the town from the south. In the market place is the Town Hall and the Clock Tower, containing the bells of the town, on which the curfew is still rung nightly. About one mile to the west, on the banks of the Wansbeck, are the remains of Newminster Abbey, destroyed after the dissolution of the monasteries, and recently partially restored. Another mile in the same direction brings us to the remains of the Norman castle of Mitford.

Hexham, twenty miles west of Newcastle, is the centre of a district full of antiquarian interest. The town itself is of Roman origin and is situated on a terrace overlooking the valley of the Tyne. The beautiful old

Abbey Church is said to form a veritable textbook of the Early English period of church architecture, and the Crypt, built of Roman stones, is of special interest. The Moot Hall and the Manor Office are two ancient buildings in the Market Place at Hexham.

Blanchland, about ten miles south of Hexham, figures much in Sir Walter Besant's historical novel of *Dorothy Forster*.

Tynemouth is situated on the north side of the mouth of the river, with its Castle and Priory forming prominent features. From here northward to Whitley Bay the cliffs are bold. This part of the coast is "Newcastle-by-the-Sea," and is within easy reach of the city by electric train. At South Shields, which stands on the south bank of the river opposite Tynemouth, is a Roman Camp.

Jarrow, on the south side of the river, midway between Newcastle and the sea, is famous apart from its industrial renown, for it is the home of the monastery in which the Venerable Bede, the head of the most famous school of learning in Europe, lived and laboured and died (673-735).

Durham is fourteen miles south of Newcastle, and is the capital town of County Durham. It is famous for its magnificent cathedral, unrivalled alike in situation and in architecture. The Castle is now



FIG. 4.—Roman milestone standing at Chesterholm.

the centre of the University, with its Colleges of Medicine and Science situated in Newcastle.

A Convocation is to be held at the University of Durham during the meeting of the British Medical Association, and members will have the opportunity of being present at the ceremony.

[The illustrations to this article are reproduced by permission of Messrs. Gibson and Son, of Hexham.]

England and Wales.

PAYING PATIENTS IN BRISTOL HOSPITALS.

At the Royal Infirmary and General Hospital, Bristol, arrangements have been made for the admission of paying patients. After preliminary discussions, which lasted for more than a year, the committees and medical staffs of the two institutions agreed upon an identical scheme. This scheme was approved by the governors of each charity at general meetings held on May 25th and 26th. It provides that all in-patients able to do so shall pay up to 1 guinea a week towards the cost of their maintenance, that out-patients shall pay a small fee for each attendance, and that almoners shall be appointed at each institution. The rules of each charity, that such persons only shall be admissible as are unable to pay for medical advice and treatment, remain in force and have been reaffirmed. The following resolution was submitted by the honorary staff of the Royal Infirmary to the committee and governors:

In order to enable the governors to bring into operation the proposals for the admission of paying patients, the honorary staff desire to offer their gratuitous services to all patients who are found after inquiry by the almoner to be unable to pay more than the cost of their maintenance. But in the case of patients whose payments are defrayed by public authorities or approved societies, the honorary staff will attend and treat such patients in consideration of an agreed percentage of the gross payment received by the Royal Infirmary being allocated to and paid into a fund which shall be administered by the honorary staff.

At the meeting of the governors of the Bristol General Hospital the honorary staff made verbally a similar offer of their services, excepting that they were not prepared to go so far as to attend gratuitously all patients who might be able to pay the whole cost of maintenance. The issue is not in itself of much moment; it is of considerable importance, however, to have a "contract of service" between hospital governors and staff so clearly defined with a view to present and future developments in hospital management and finance.

SCHOOL OF NURSING AT THE LEEDS INFIRMARY.

When the original part of the present infirmary buildings, with its five ward pavilions and its administrative pavilion, was opened in 1868 by King Edward VII, then Prince of Wales, it is said that the number of nurses employed at the infirmary was only 20, and the accommodation for even that small number appears from the plans to have been singularly inadequate. The original nurses' home was added in 1880 and was enlarged in 1885. The enlargement of the infirmary in 1892 necessitated further accommodation being secured, and the new nurses' home was opened in 1898. In 1907-8 it was again found necessary to increase the staff, and temporary but very satisfactory accommodation was secured by adapting some houses which had come into the possession of the infirmary in connexion with the purchase of the land for the King Edward Memorial Wing. The nurses now number about 170. Of late years a great deal has been done to systematize the training of the nurses, to widen their experience, and to

afford those who show special aptitude every facility for acquiring these branches of knowledge which are necessary for the proper carrying out of the duties of matron or superintendent. Candidates for training must be between the ages of 20 and 30; they are all appointed by the board on the recommendation of the lady superintendent, who interviews those who apply. They are admitted as pupil nurses for three months' trial, six to eight weeks of which are spent in the preliminary training school. During this period they receive lectures in elementary anatomy and physiology from the professors of these subjects at the university or from members of their staffs, and they also attend lectures on practical nursing and sick-room cookery. Before entering the wards they have to pass a satisfactory examination in the work they have done during this preliminary stage. In their preliminary training they are under the personal supervision of a special sister tutor and receive tutorial instruction from her. At the end of this period of special probation, if they are found to be satisfactory and likely to prove efficient nurses with training, they are, after a physical examination conducted by a member of the honorary staff, admitted to training in the hospital, and are required to remain in the service of the hospital for twelve months from the date of their beginning their preliminary training. If they desire to continue their training, and are approved, they then sign on for a further period of three years, so that at Leeds the training extends over a term of four years and no nurse now gets her certificate on a shorter curriculum. The institution of the preliminary term of training has proved a great success. It has shortened the time it takes to make a nurse of real use; it gently eliminates those who are not likely to make efficient nurses, and it lays the foundation for a more accurate and scientific acquaintance with the different departments of nursing.

During the hospital training lectures are given to first year nurses on practical nursing and bandaging and on anatomy and physiology, to second and third years' nurses on surgery, medicine, and on ophthalmic and aurial work, and during the third and fourth year on midwifery and gynaecology and on hygiene. The hospital certificate is awarded on the results of a terminal examination and on the report of the character of the nurse's work as evinced by term examinations and testified to by those under whom she has worked. Twenty scholarships providing free training for the certificate of the Midwives Board are given annually to selected nurses during their final year; class prizes are awarded also. During the fourth year the nurses receive the title of Staff Nurses, and from these promotions are made by the board, on the recommendation of the Lady Superintendent, to the position of "Sister" (15 Heads of Wards, Casualty and Out-patient Sister, and Theatre Sister). Four of the staff nurses are selected yearly to receive special training in housekeeping under the Lady Superintendent and her deputies. The training at Leeds is now believed to be of the highest standard. The comfort of the nursing staff has been the subject of sympathetic thought on the part of the board; the salaries have been increased, the time for recreation has been extended, and tennis courts have been provided by the kindness of the late Mr. Frank Gott, whose recent death is greatly regretted by his colleagues on the board as well as by everyone connected with the infirmary.

A further step will in all probability shortly be taken by which it is hoped that the University of Leeds will grant diplomas in nursing. The regulations are being very carefully drawn up and scrutinized, and it would not be right at present to say more than that both the University authorities and those who advanced the scheme in the first instance are keenly alive to the advisability of maintaining a high standard of general education and of technical training and knowledge. When the scheme is decided upon by the University the details will be given in this column.

COUNTY MATERNITY HOME AT BISHOP AUCKLAND.

The first County Maternity Home under the Durham County Council was opened recently at Bishop Auckland. Dr. Janet Campbell, chief maternity and child welfare medical officer at the Ministry of Health, was present, and congratulated the county on its excellent maternity and child welfare work. She said that there

were still far too many maternal deaths from childbirth, and although death did not often result, many mothers were crippled in health for years afterwards through unskilled attention. There was a great need for small maternity homes of this type, and the Treasury had realized this, and had permitted the Ministry of Health to expend money on such beds when it refused grants for other schemes for maternity and child welfare. Councillor Barron, who was the recipient of a presentation in appreciation of his help in furnishing and equipping the home, referred especially to the fact that the preference in beds would be given to mothers whose home conditions were unsuitable for confinements and to those with complications in pregnancy, but, if beds were available, patients able to pay the full charge of three guineas a week would not be refused admission.

The County Maternity Home is to be managed by a joint committee consisting of members of the Maternity and Child Welfare Committee and of the County Nursing Association. The county medical officer acts as executive officer, and the senior welfare medical officer as advising medical officer of this committee. Any patient who so desires may be attended by her own doctor. Where no doctor has been engaged the matron will conduct the labours, but to ensure adequate medical attendance a rota of doctors resident in Bishop Auckland has been arranged; each will act for three months at a time, and if the acting doctor is not available the next on the list will be summoned. One of the welfare medical staff of the County Council will visit the home twice weekly and give the necessary lectures to the midwives when the home is approved as a training school. The home is a modern three-storied house, and it has accommodation for seventeen mothers and babies, and a resident nursing staff. Arrangements have been made for the training of midwife pupils, and already several patients have been admitted to the home.

HEALTH OF LONDON.

The report of the medical officer of health to the London County Council for the year 1919 has just been issued. The general arrangement follows very much the lines of previous reports, and a document dealing with the concerns of over four million persons, and with the varied and various public health enterprises of the present day, cannot but contain many matters of profound interest not only to the hygienist but to the general public. The earlier pages are concerned with vital statistics, the incidence of infectious disease, and the public health administrative activities of the County Council. The chapter dealing with the school medical service is attractive because it recounts the gradual return to normal conditions of a vast public service which, during nearly five years, had been endeavouring to carry on its work with a largely reduced staff and with the public purse-strings gradually tightening. Included in the appendices is a detailed report by Dr. F. N. Kay Menzies, Principal Assistant Medical Officer in the Council's Public Health Department, on the arrangement for the treatment of tuberculosis in London, and a memorandum on the treatment of tuberculosis presented to the Insurance Committee for the County of London by their medical adviser, Dr. Noel D. Bardswell. We propose to make more extended reference to this report of Dr. Hamer in a later issue of the JOURNAL.

MEDICAL DEPUTY-LIEUTENANTS FOR LANCASHIRE.

The following members of the medical profession have been appointed Deputy-Lieutenants for the County Palatine of Lancaster: Sir James Barr (Liverpool), Mr. Arthur H. Burgess (Manchester), Dr. Archibald Donald (Manchester), Dr. T. Wheeler Hart (Manchester), Dr. John Hay (Liverpool), Dr. C. Thurstan Holland (Liverpool), Sir Robert Jones (Liverpool), Dr. C. J. Macalister (Liverpool), Dr. G. R. Murray (Manchester), Mr. R. W. Murray (Liverpool), Dr. George Parker (Bolton), Dr. E. S. Reynolds (Manchester), Dr. Alexander Simpson (Warrington), Mr. J. W. Smith (Manchester), Sir William Thorburn (Manchester), Dr. C. J. Trimble (Penwortham, near Preston), Dr. John Utting (Liverpool), Mr. P. H. Westmacott (Manchester), Dr. Alexander Wilson (Manchester).

Ireland.

MEDICAL MEMBERS IN THE ULSTER PARLIAMENT.

THREE medical men have been returned as members of the Ulster Parliament; they are three of the four representatives of the Queen's University of Belfast; no medical men stood for any of the other constituencies. The voting for the university representatives stopped at 5 p.m. on May 28th, and at 8 p.m. the returning officer (the Vice-Chancellor) announced that the four successful candidates were Dr. John Campbell, F.R.C.S.Eng., Mr. R. J. Johnstone, F.R.C.S.Eng., Mr. John H. Robb, barrister, all of Belfast, and Dr. Hugh S. Morrison of Coleraine, co. Derry. There were three counts.

THE ULSTER MEDICAL SOCIETY.

The annual general meeting of the Ulster Medical Society was held in the Medical Institute, Belfast, on May 26th, with the President, Dr. Thomas Houston, in the chair. The council's reports were read by the secretary, the treasurer, and the librarian, and passed with slight amendments. The following office-bearers were elected for the ensuing session: President, Dr. Robert Hall, Belfast; vice-presidents, Mr. James C. Craig, Belfast, and Dr. G. L. St. George, Lisburn; council, Professor Lowry, Mr. Howard Stevenson, Dr. W. Burns, Dr. V. G. L. Fielden, Dr. S. B. Boyd Campbell, and Dr. Maitland Beath, all of Belfast; honorary treasurer, Dr. S. I. Turkington; honorary librarian, Dr. W. L. Storey; honorary secretary, Dr. W. W. D. Thomson; honorary editorial secretary, Dr. R. Marshall. A resolution of sympathy was passed with Dr. W. W. D. Thomson in his prolonged illness, and Dr. Marshall was thanked for his able discharge of the double duties. A prolonged discussion took place on the honorary treasurer's statement of accounts, as they showed a serious increase in the annual deficit, which had been small but increasing in past years; the general upkeep had been interfered with and some pressing repairs to the building were required by the trustees. It was finally agreed that a request, accompanied by a copy of the statement of accounts, be sent to all fellows and members, asking them to increase their subscriptions voluntarily by at least 50 per cent. for the ensuing year. Should this appeal fail, it would, it was thought, become necessary to raise the subscription to the society, though this would be done with great regret.

SIR PATRICK DUN'S HOSPITAL ROLL OF HONOUR.

Sir Patrick Dun's Hospital, Dublin, has cause to be proud of the honours which her old students won in the great war, for the 418 past and present students who served gained no fewer than 244 distinctions. The Roll of Honour, which contains the names of the old students and their distinctions, has just been published, and is accompanied by a photograph of the war memorial which was unveiled in the hospital last December, as was noted in our columns at the time. The memorial was erected at the exclusive cost of the survivors of the 418, and in addition a memorial bed was endowed in the hospital. On the memorial are the names of thirty old students who laid down their lives, including the following medical men:

Lieut.-Colonel Sir Charles B. Ball, Bt., Lieutenant W. O. W. Ball, Captain A. C. Bateman, M.C., Fleet Surgeon H. L. Geoghegan, Lieutenant H. R. Griffith, Colonel William Hallarau, Lieutenant F. G. Hopkins, Major P. G. Hyde, Captain Kingsmill W. Jones, D.S.O., Major J. T. McEntire, Légion d'Honneur, Captain E. J. McSwiney, Captain H. R. Robertson, Captain Edmond Robertson, Captain C. G. Sherlock, Major R. S. Smyth, Lieutenant George Taylor.

THE next meeting of the French Orthopaedic Society will take place this year on October 5th at Strasbourg, when discussions will be opened by MM. Froelich (of Nancy), Ombredanne (of Paris), and Tavernier (of Lyons).

THE Ophthalmological Society of Vienna announces an extraordinary meeting to be held from August 4th to 6th. On the first day a discussion will take place on the success of the latest operation for glaucoma compared with the classical Von Graefe iridectomy, to be opened by Drs. Uthoff and Wessely; other scientific meetings and demonstrations will be held on the following days. The secretary of the meeting is Dr. M. Lauber, Alserstrasse, Vienna VIII.

Correspondence.

THE FUTURE OF RESEARCH IN TROPICAL MEDICINE:

Facilities in Mauritius.

SIR,—Here in the island once known as "the Star and Key of the Indian Ocean," but now unfortunately possessing the unenviable notoriety of being the most unhealthy of British colonies, I read with much interest the account of Sir Leonard Rogers's address on the above subject in the *JOURNAL* of March 12th. He has unfortunately been misinformed as regards British East Africa, where, at Nairobi, a laboratory has existed for years, and where, long before the war, good work was done by Philip Ross, Harvey Pirrie and others. This laboratory, however, is poorly housed, and a new building is to be erected which will contain special rooms for research workers, apart from the accommodation provided for the staff.

Few, I think, who know the tropics but will agree wholeheartedly with Sir Leonard Rogers's arguments and plea for help. In Mauritius there is a case in point, though Mauritius is more fortunate than many places, for since August, 1907, it has had the benefit of an excellent little laboratory situated at Réduit. The building on the whole is well equipped, and is under the able direction of Dr. L. G. Barbeau, an old student of the London School of Tropical Medicine and of the Pasteur Institute, Paris. Unhappily he is hampered in his work, for he is understaffed and has to carry out many duties which should not fall to his lot. Furthermore, the laboratory is, unfortunately, situated far away from any large centre of clinical work. It is eight miles from Port Louis, the capital, where there is a big civil hospital, and it is a considerable distance from the new central hospital now in process of erection at Caudos. The only hospital anywhere near it is that which serves the Moka district, and which chiefly admits surgical cases. This is certainly a drawback, but the disadvantage is to some extent minimized by the fact that the island possesses capital roads, and material can speedily reach the laboratory by motor car. Doubtless the present site was selected because Réduit is much cooler and healthier than Port Louis, but there can be no doubt that, for purposes of research at least, it would have been wiser to attach this laboratory to the civil hospital in the capital, where it could also have readily served the needs of the Port. Still, as it is intended to meet the requirements of the whole island in some respects, its position is suitable.

The history of the institution is interesting. It owes its origin largely to the energy of a well known Maurician, Sir Henry Leclézie, K.C.M.G. He it was who induced a French army surgeon, Dr. Lafont, to leave Réunion and become the first director of the laboratory in Mauritius. Under Lafont the laboratory did good work, and indeed gained a measure of fame owing to the discovery by David, one of Lafont's assistants, of the flagellate of the Euphorbia, now known as *Leptomonas davidi*, a discovery which has had an important bearing on certain problems in protozoology. In 1911 Lafont left Mauritius, and Dr. Barbeau, in addition to other duties, supervised the work of the laboratory. In 1914 he was confirmed in the post of director. He has maintained the reputation of the laboratory, the services of which are in great request. As a result Dr. Barbeau and his few assistants are overwhelmed with routine work of all kinds, though praiseworthy attempts are made to conduct research, and though useful observations have been recorded it is well-nigh impossible at present to make much progress. Yet what a field of work is presented by Mauritius! The incidence of filariasis has never been ascertained; the actual mosquito vector of *Filaria bancrofti* remains unknown; despite serious efforts by Dr. Momple and Mr. Maya, the snail host of *Schistosomum haematobium*, the only human schistosomo found here, has not been discovered.

There is a fine opening for entomological research in several directions, and it is possible that undifferentiated fevers exist. Surra occurs, but the fly which transmits *T. evansi* in Mauritius has not yet been determined.

A recent report by Dr. Kendrick, of the Rockefeller Foundation, has shown that ankylostomiasis is exceedingly prevalent. He estimates that no less than 226,000 persons

in the colony are infected, and in one district—that of Moka, in which the laboratory is situated—90.6 per cent. of the inhabitants harbour the helminth. Other worm infections are exceedingly common, and so, be it noted, is appendicitis.

From the hygienic point of view the resources of the laboratory could be utilized in many directions, and they must be so utilized if the island is to be made healthy. Much yet remains to be done as regards the incidence of malaria. Major Fowler's suggestion as to the necessity of further research into the rôle of *Anopheles mauritianus* as a carrier has never been acted upon. The precise value of the spleen index test requires to be determined, and the causes, apart from malaria, which induce splenomegaly should be the subject of careful inquiry. These are but a few of the questions which await the research worker here.

Mauritius is a good place for the pursuit of science. It is isolated, but there are few distractions. It possesses in some degree the peaceful atmosphere which is so favourable to research. It is small, the size of Surrey, and yet as full of problems and pathological conundrums as an egg is full of meat. Its leading medical men are well acquainted with the existing conditions, and would, I feel certain, welcome keen research workers from home. As is usual in these latter days, our good friends, the Americans, have been before us. What Dr. Kendrick thought of the sanitary condition of the island, and more especially of its capital, I can only imagine. Yet progress in sanitation must always be largely dependent on research in the laboratory. When are we going to wake up?—I am, etc.,

ANDREW BALFOUR.

Port Louis, Mauritius, April 30th.

THE TREATMENT OF ACUTE TOXAEMIA.

SIR,—The cells of many types of living beings, unicellular and multicellular, secrete poisons—endotoxins for defensive and exotoxins for offensive purposes. The microbes of disease, insects, snakes, and numerous plants furnish examples. All our vegetable medicines are endotoxins which, by means of poisonous action often combined with disagreeable taste, protect the producing plants from animal enemies. In chronic diseases—for example, tuberculosis and leprosy—the poisons are mainly endotoxins; in acute diseases—for example, measles, pneumonia, diphtheria, septicaemia—they are exotoxins. Fever is a reaction to toxæmia.

While experience of some poisons—for example, strychnine, quinine, and tuberculin—confers little or no added power of resistance, it is possible to train the individual to increased tolerance of other poisons—for example, nicotine, opium, snake and insect venom, and the toxins of the acute diseases. It is unnecessary to discuss the vexed question as to how this tolerance arises; bacteriologists have formulated many suppositions; but presumably it is in essence what biologists call "a use-acquirement," a product of functional activity, an habituation. The individual becomes "used" to, accustomed to, educated to toxins, and in recovery from acute disease his cells, no longer poisoned to impotence, are able, as a consequence, to attack and destroy the pathogenic organisms. Hence recovery and acquired immunity, temporary or permanent.

This habituation may be achieved in three distinct ways:

1. By beginning with small and proceeding to larger and larger doses of toxin, as in tobacco and opium smoking, and when diphtheria toxin is administered to a horse during the manufacture of antitoxin.
2. By beginning with and maintaining in action one large dose, as happens in acute disease which is followed by recovery.
3. By antitoxin and vaccine treatment, the rationale of which, as I say, need not be discussed.

The second method is exceedingly dangerous, and is the cause of death in disease. The last method has been attempted in many infectious, but as yet it has been conspicuously successful in only a few acute diseases—for example, diphtheria and small-pox. Were it possible in acute illness to combine antitoxic serum with small doses of toxin, we should have an ideal method of cure. But serums for many acute diseases are lacking.

Moreover, in illness the patient is already suffering from a large dose of toxin, which the introduction of small doses from outside would only make larger. Consequently, during illness, the only conceivable method of causing a sufferer to experience small doses is to reduce the amount of toxin in him. I do not know that this has ever been consciously attempted. I believe, however, it is not impracticable. In other words, I believe it is possible to abstract toxin from a sufferer.

Consider lobar pneumonia. A portion of the lung is invaded by the pathogenic organisms; blood is extravasated; and that portion of the lung becomes more or less solid. The temperature rises, rigors occur, the patient suffers from headache, sleeplessness, and a general feeling of illness. The severity of the disease is not at all strictly proportionate to the amount of lung involved, but depends rather on a toxæmia which especially affects the heart and breathing centres. In favourable cases a "crisis" occurs about the fifth to the tenth day. Commonly the patient sleeps, and awakes some time later feeling much improved. His temperature has fallen, his headache, rigors, and sleeplessness have gone, and he is bathed in sweat. Apparently the condition of his lung has not altered; but later gradual resolution occurs, and the extravasated and disintegrated blood is voided as "rusty" sputum.

Sweating is Nature's mode of cooling the healthy body by evaporation from the surface. But if, as usually happens in pneumonia, the patient is thickly covered with bedclothes and evaporation prevented, the temperature still falls. Presumably, therefore, something more than mere exudation and evaporation of fluid occurs in the crisis—something which in itself causes the fall of the temperature and the general improvement. I can conceive no reason for such a sudden change except a quick elimination of toxins, and, in view of the lack of evidence of increased activity in other possible channels of elimination, I cannot conceive by what road the toxins can be passed out if not by the sweat. I know of no evidence that toxins have been found in the sweat; but then, I do not know that they have been sought there.

Since recovery from acute diseases is associated with a falling temperature, moisture of the skin, and sleep, the administration of antipyretics, sudorifics, and soporifics was formerly common. But the medicines and the dosage generally employed depressed the heart and breathing centres, and of late it has been regarded as almost axiomatic that antipyretics and sudorifics are injurious under such conditions.

But if we give a patient, suffering from pneumonia, for example, and not already poisoned past redemption, the following dose, aspirin 10 grains, phenacetin 5 grains, and 1 pulv. ipecac. c. 5 grains, we get (as far as my experience goes) what has all the appearance of an artificial crisis, without depression of the heart and breathing centres, or any other ill effects. The patient soon falls asleep, and wakes up some hours later feeling much better, bathed in sweat, his temperature down, his rigors and headache gone, and his pulse and breathing improved. The signs of illness will gradually return, but they can be abolished in the same way once or twice a day till permanent improvement sets in. On such occasions the patient will be relieved and rested, and, unless my experience has been unusual, his illness shortened.

Lately I myself fell ill of lobar pneumonia. I began the treatment I describe about the third day, having previously received ordinary treatment, but I know no good reason why I need have waited so long. My most vivid recollection is the immense and blessed sense of relief that followed each dose. I fell asleep within half an hour. After waking I was able for some hours to read or converse with comfort—indeed, with little feeling of illness. I suppose I took six or seven doses in all. Within a week I was writing at my desk. On the tenth day of illness I was taken for a thirty miles motor drive in the country. On the twelfth day I was walking about visiting friends at their own houses. On the thirteenth day I was back at full medical work, feeling none the worse. I am not young. I voided not rusty sputum but bright blood, showing rapid resolution. As well as I am able to judge, at each artificial crisis toxins were eliminated in large quantities, and the body was thus presented with several small doses, instead of having to make head against one continuously large dose. Certainly while my temperature was high I felt poisoned; during the intervals I felt, or seemed to feel, relief from poisoning. Apparently my sweat centre was roused to activity, while my heart and breathing centres were relieved by the elimination of the toxin.

I have never known ill results follow this treatment, though it has been tried lately in a fair number of cases, both by myself privately and by friends in hospital practice. The following is a fair sample of cases:

Lobar pneumonia (advanced stage). No improvement followed treatment. Death. Apparently the patient was poisoned beyond redemption.

Lobar pneumonia (early stage). The temperature was taken as a guide and several doses given. This case followed a course very similar to that in my own illness. Patient was up and about on the tenth day.

Bronchopneumonia following suicidal immersion. Only one dose was given. Sleep; sweating; temperature fell, and never rose again. Recovery, but "vast quantities of sputum were voided for four days."

Mild rheumatic fever. Some temporary relief followed each dose, but apparently no permanent improvement, though treatment was long continued. But aspirin has been found very useful in this disease. How does it act? Hardly as an antiseptic.

Diphtheria. Twenty thousand units of antitoxin given about the same time as the dose. Sleep; sweating. Patient awoke declaring himself recovered. Temperature never rose again. No further treatment necessary. Presumably, in this case the swift reaction to the antitoxin occurred because much of the toxin had been eliminated. That is, serum treatment was combined with a small dose of toxin.

Measles in child of 6. Beginning of eruptive stage. Severe photophobia; diarrhoea; cyanosis, so that mother remarked on "white appearance about the mouth." Temperature 103°. Dose (1/6 adult) given. Patient passed a good night. When seen next morning was sitting up playing happily in bed. Slight cough; rash fading. Temperature normal; no diarrhoea, cyanosis, or photophobia. Immediate recovery.

Two cases of measles; average severity. Doses given. One child much and the other little improved next day. Two more doses given. Both children nearly recovered that day.

Threatened breast abscess a week after childbirth. Temperature 101.5°; sleepless; acute headache. Bad mental condition. Dose given. Slept; sweated; awoke feeling much better in mind and body; temperature normal. Threat of abscess gone. No further treatment.

Diphtheria. Only one dose given, which apparently had no effect, good or bad.

Enteric fever. Only one dose given, which apparently had no effect.

Septic infection of ureter. Rigors; temperature 105°. Effect of doses as in my own illness. Quick uncomplicated recovery in a week.

Two cases of *pyrexia of uncertain origin*. One dose given. Sleep; sweating; recovery.

These are sample cases. Up to now the suggested treatment has apparently given such good results in many cases that I have hopes that it will prove generally useful in the treatment of acute toxæmia—for example, in puerperal fever, surgical sepsis, tetanus, small-pox, and the like. But medicine is full of decaying mare's nests. It is never wise to trust to the experience furnished by a few cases to a few men. I venture, therefore, to ask if some of your readers, medical and surgical, will try this treatment, and either publish their results or inform me of them. Obviously, even if the treatment be useful in some acute diseases, it is sure not to be useful in others; the combination of drugs I suggest may be improved on; there may be a right and a wrong stage in each disease for the commencement of treatment, and so on.

I suggest that in every instance the trial shall begin by giving a single dose in a single suitable case. If the results are not unfavourable, the treatment may be continued and the experiment extended. My own experience has been such that I feel very confident. But that, I suppose, is the way of all beginners. It should be noted that I suggest an addition, not an alternative, to ordinary treatment. The extreme simplicity of the suggested addition is liable to create scepticism; and though simplicity does not always imply inefficiency, unfortunately it often does. However, the test and perhaps the improvement of this "reduction" treatment is easy.—I am, etc.,

Southsea, May 20th.

G. ARCHDAL REID.

THE SITE OF OPERATION FOR EMPYEMA.

SIR,—Selection of the most suitable site for rib resection is not governed by definite rules, but depends on the situation of the collection of pus. For a general pyothorax or pyopneumothorax the authorities which I have consulted—British, French, and American—with one exception, prefer the eighth or ninth rib, just external to the angle of the scapula, with the arm horizontal—that is, at the most dependent attainable part of the cavity. Resec-

tion for encysted or localized empyemata should be—when x-rays are not available—as near as possible to the mark of the lowest successful exploratory puncture. The technique of the operation and subsequent treatment are probably of more importance than the position of the incision, and a brief summary of the notes of 78 cases of pleural suppuration with resection under my care in Franco during 1917 and 1918 may be of interest.

Thirteen of these were unwounded, such empyemata as we meet in civil practice, and as, with one exception, the explorations or x-ray findings had indicated the ordinary site, this was chosen, and the results proved satisfactory, though in two cases it was found necessary to break down adhesions with the finger a couple of days later in order to set free loculated collections. The after-treatment differed from that described in the textbooks in that the lavage which they condemn was always employed, unless such complications as bronchial fistula or pulmonary abscess forbade.

My notes on the 65 resections for empyema or pyothorax following penetrating wounds of the chest confirm the good effects of irrigation especially by Carrel's method, but here a far more virulent infection was encountered. In many cases a sudden and extensive pneumothorax was the first indication of the presence of *Bacillus welchii* and immediate resection was the only course. A Turner's tube now and then relieved the extreme urgency, but in two only averted the need for a larger opening. The deaths, of which I have unfortunate record of twelve, were due to complications not likely to be met with outside military surgery, but the causes of three are of particular interest. The first of these was apparently doing well when seen in the morning, but in the afternoon developed a huge left pneumothorax from gas-bacillus infection, the heart being completely dislocated to the right side. Operation half an hour earlier might have saved the life.

Resection in the other two was soon followed by surgical emphysema, which rapidly spread from chin to hip, but ceased to increase on readjustment of the tube. This complication also happened in two non-fatal cases, and we were quite unable to explain how a positive pressure was set up sufficient to force air among the connective tissues. Such an accident might conceivably occur in civil practice.

So many of the remainder were similar to empyemata of non-traumatic origin that the knowledge acquired in their treatment may well be applied to our ordinary work. In the first place, the utility of x-rays in localizing pus must be emphasized. Gregoire is very definite:

"Exploratory puncture enables us to establish the existence of pus and the point where it is present, but it cannot tell us the limits of the collection. The surest way of ascertaining the site and lower limit of the cavity is incontestably puncture with a trocar guided by the radioscopic screen."

Secondly, I would like to record the excellent results that followed irrigation by Carrel's tubes. In localized collections the method of insertion is similar to that employed with deep septic wounds, but for a general pyopneumothorax the tubes are "armoured" with a silver stylet and their correct position ascertained by x-rays. For the former three or four tubes are sufficient; for the latter as many as eight or nine may be required. The original intention was to reduce the infectivity of the pus to such a level as would permit of closure of the wound, and thus avoid extensive adhesions and promote early expansion of the lung. Frequent examinations of the number of organisms in a field were made, but only in two cases was the original aim attempted, and one of these had subsequently to be reopened. The ideal of Tuffier and Depage failed, but the early clearance of pus, the dissolution of purulent flakes, the ease to the patient, and the rapid general improvement were remarkable.

Thirdly, it must be remembered that cure is only complete when the lung returns to contact with the parietes, and every effort must be made to promote its expansion. Breathing exercises, whistling and playing wind instruments, are not willingly carried out by the resected nor cheerfully borne by their neighbours, but spirosopic and suction methods of reducing intrapleural pressure should be employed wherever possible.

Fourthly, the benefit of open air and sunlight cannot be over-estimated.—I am, etc.,

Westcliff-on-Sea, May 23rd.

T. B. SELLOES, M.D.

VITAMINS AND DENTAL CARIES.

SIR,—There are indications that the fat-soluble A theory of the causation of rickets is not satisfactory, and if the experiments of Professor Noël Paton and Mr. A. Watson (BRITISH MEDICAL JOURNAL, April 23rd) have not demolished this vitamin theory, they must at least have tempered the enthusiasm of its advocates. Naturally, Professor E. Mellanby (BRITISH MEDICAL JOURNAL, May 28th) does not abandon the theory, and even adopts the idea that lack of fat-soluble A in the diet is the "all-important factor" in the causation of dental caries! The contention that defective calcification of the teeth is responsible for the prevalence of dental caries is not new. It was, however, set aside by the dental profession years ago, after the late Professor G. V. Black's classic investigation into "the chemical and physical properties of the teeth" left no other course open. Having made an extensive chemical and physical examination of teeth, Black came to the conclusion that—

"the teeth of persons who suffer much from caries are just as hard, just as heavy, and contain just as much lime salts as the teeth of persons who do not suffer specially from caries."

In different teeth there are certain differences. Sir Charles Tomes gives the percentage of lime salts for the incisors as 71.5, and for the molars 73.2. These figures are practically the same as those recorded by Black, and more recently by Gasman. Yet, as is well known, the molar teeth are more frequently ravaged by caries than are the incisors. With regard to the microscopic structure of the teeth, Dr. Leon Williams showed years ago that—

"the finest lenses reveal not the slightest difference between enamel ground moist from a living tooth and that which has lain in the earth for a hundred centuries."

If fat-soluble A had anything to do with the prevalence of dental caries, why should we find that it increased with the increased consumption of such foods as butter, eggs, and animal foods. Together with an increasingly higher standard of living last century there was a corresponding increase of dental caries. Similarly, we learn from statistics that "the better the school the worse the teeth." On the other hand, during the war, when there was a notable scarcity of animal fats, milk, butter, and cream, what statistics we have indicate that there was a decrease in the prevalence of dental caries. There was, of course, a great reduction in the amount of sugar, sweets, etc., consumed, and the decrease in caries goes a considerable way to corroborate the "official" theory of the cause of the disease. I am not trying to indicate that meat, butter, and fats generally are harmful to the teeth; most dentists would agree that these foods are detergent in their effects, and had it not been for the shortage of these foods during the war the benefit of the restricted consumption of concentrated sugar (sweets, jam, etc.) would no doubt have been more conspicuous.

Consider the subject from another point of view. At the present day the temporary teeth of children are ravaged by caries, yet these teeth are calcified before the age when rickets is liable to supervene, and unlike the rachitic puppies under Professor Mellanby's care the temporary teeth of children, as a very general rule, take up a regular position in the jaws. Moreover, as a matter of fact, hypoplasia of the temporary teeth is most exceptional. In a recent investigation Mr. A. T. Pitts found only fifteen teeth showing hypoplasia in at least 4,000 cases. Yet caries of the temporary teeth is even more rampant than caries of the permanent teeth. Professor Mellanby may be disappointed in noting the conclusions which others draw from Professor Noël Paton's experiments on puppies, but his digression from rickets to dental caries does not appear likely to restore his fallen idol.—I am, etc.

London, W., May 28th.

J. SIM WALLACE.

ECLIPSE BLINDNESS.

SIR,—Dr. Lodge and Dr. Maxted describe serious cases of eclipse blindness, in which there was no visible change in the fundus oculi, although the vision was much impaired. I saw two less serious examples of this distressing result of exposure of the retina to the solar rays, and it may be of interest to send a few observations I made regarding them.

The general features of these cases were: (1) the short

time of exposure to the sun; (2) the presence of visible changes in the fundi; (3) a temporary central scotoma with diminished visual acuity; (4) complete recovery.

I will describe one of the cases more fully.

Miss E. T., aged 27, observed the eclipse on April 8th, 1921, for a few seconds only; she did not use any protective glass or other medium. On account of the photophobia she experienced, she at once desisted, but a little later noticed that vision was blurred. On the following day she attended the Birmingham and Midland Eye Hospital, complaining that since she had looked at the sun "things were blurred and she could not see the centres of things."

The visual acuity in each eye was 6/18, and the field of vision, normal with regard to its periphery, showed a small relative central scotoma. At each macula there was a yellow glistening line, which magnified by the direct method of opththalmoscopy was about an eighth of an inch in length. There was also slight pigmentation around the maculae. The patient was prescribed potassium iodide and ordered to wear No. 3 smoked goggles for a time.

On April 23rd I examined the fundi again, but could find no sign of the changed appearance described above. On the occasion of each examination a mydriatic was used. On this day the vision was 6/6 in each eye. I saw the patient again on May 21st, and the visual acuity was unchanged and colour vision was normal. There was no central or paracentral scotoma, either relative or absolute, for white or coloured objects.

For permission to record the above case I am indebted to Mr. Fulford Bates.

With the suggestion that the public should be fully warned regarding the danger of observing eclipses without proper precautions I heartily agree. It seems remarkable that eclipse blindness occurs in such a small percentage of the interested observers.—I am, etc.,

H. W. ARCHER-HALL, D.O. Oxon.,

Assistant Surgeon, Birmingham and Midland Eye Hospital.

May 23rd.

THE PREVENTION OF PUERPERAL INFECTION.

SIR,—Once again the general practitioner is being subjected to a more or less well-deserved criticism in respect of his midwifery. Last year a somewhat heated controversy took place in your columns along similar lines, more particularly concerning the use of forceps in relation to the relief of pain. Towards the close of the discussion one correspondent went so far as to state that the "agony" of childbirth was a myth, and indirectly suggested the abolition of chloroform anaesthesia in labour.

In so far as the general practitioner is concerned, the fault lies at the door of the teaching schools, or, to be more precise, at the door of those responsible for the college curriculum. It is not that facilities are limited. They are not; on the contrary, they abound, but unless the student is particularly interested in obstetrics, he will not take advantage of them. He is not compelled to do so, as he is in the case of medicine and surgery. For some obscure reason, obstetrics—the oldest of the three arts—has not been permitted to share the same scientific standing as medicine and surgery. The subject has been neglected. It forms a very hurried, insignificant part of the student's final year, consisting of, at the most, six months' theory, followed by the personal management of twelve cases of normal labour in the district of a maternity hospital. The application of forceps or the attempted treatment of an abnormal case is strictly prohibited. So long as the regulations are complied with and a ticket is produced certifying that a course of lectures has been attended, and that twelve cases of labour have been undertaken, the authorities are presumably satisfied that that is all the experience required to practise obstetrics. The student is examined in theory, no clinical examination being considered necessary, and is then thrust upon a trusting public as a fully-qualified (*sic*) obstetrician.

In your issue of May 21st a correspondent makes the suggestion that midwifery should be a specialized subject, kept apart from general practice, and undertaken only by those to whom the work offers a special attraction. This would seem to be the ideal both to the practitioner who dislikes obstetrical work and to his patient. To those in general practice who specialize in obstetrics but dislike the remainder of their daily routine this suggestion, if materialized, would be a godsend; but, as your correspondent rightly says, the present scale of fees prohibits the occurrence of any such Utopia.—I am, etc.,

R. DOUGLAS HOWAT, L.R.C.P. and S.Ed.,

Hawick, May 23rd.

L.R.F.P.S.Glasg.

SIR,—Once again the subject of puerperal fever conveys heat to your correspondence columns, and I revel in it.

All are agreed on a few cold facts. Let me state them: The organisms responsible for puerperal fever are the *Streptococcus pyogenes*, including those of erysipelas; the *Staphylococcus aureus* and *albus*, also the organisms frequently associated with scarlet fever and diphtheria; pneumococci, gonococci, the organisms of typhoid and tetanus; and *Bacteria coli*. The last named has loomed large in recent years.

My figures, published in 1912, like those published by Matthews Duncan in 1876, prove that there is no connexion apparently between puerperal fever and erysipelas or scarlet fever. We may safely ignore pneumonia, typhoid and tetanus, and even gonorrhoea. We are left with the streptococci and staphylococci, and the *Bacteria coli*. If the *Bacteria coli* are responsible their source is not far to seek—namely, the mother. Personally I consider the case not proven. The streptococci and staphylococci may be traced to the mother, but again I am sceptical.

I claim to have been the first to suggest a reasonable explanation of the common source of those organisms—namely, where one would naturally look for them—that is to say, septic wounds. Now, how come they to reach the mother from septic wounds? Of course, if the mother is herself suffering from a septic wound, she infects herself; if not, they are conveyed to her by those attending her during parturition—that is, by the doctor or nurse, or both. Now, what is the common cause of septic wounds? I suggest industrial accidents are responsible for 95 per cent. To the question, How connect industrial wounds and puerperal fever? the answer is, by the individual who often treats both—that is, the medical practitioner.

I contend, without fear of contradiction, that this theory is the only one to explain the erratic and otherwise inexplicable incidence of puerperal fever.

To prove it I conceived the idea that if one classified districts according to the incidence of industrial accidents I would find the clue to explain the connexion between industrial accidents and puerperal sepsis. My book on the subject of which I still retain a few copies, and may be had for the cost of postage, proves my theory; I hold many letters from practitioners who agree with my conclusions, and I felt elated to fancy that Dr. W. Blair Bell referred to my statistics in his lecture published on May 14th.

I was not content, however, to rely on those figures only, and will give here a few others which further prove my contention. Notwithstanding the financial loss involved in my last attempt I propose again to publish a pamphlet on the subject, for like the man who found the goodly pearl I am prepared to sacrifice something to retain it.

There be few presumably who would claim any good to have come out of the great war, but even that calamity assists me in my fight for the truth. It occurred to me that there ought to be fewer accidents during the years 1915-18 (inclusive) than in normal times, so many men having to be withdrawn from industry, and if so that fact would be reflected in puerperal statistics. Unfortunately Government departments are unable to assist me in regard to accidents, but fortunately puerperal statistics for that period again prove my idea probable.

For the benefit of those still unfamiliar with my previous work—and I presume they are legion—let me briefly summarize a few chief figures and compare them with the succeeding ten years, including the war years. I have confined my present statistics to the administrative county of Lancaster.

Puerperal Rate per 1,000 Births in Classified Districts.

Lancashire Districts Classified.	(1) 1900-09.	(2) 1910-19.	(3) 1915-18 (War Years).
Mining districts	4.56	3.23	2.62
Manufacturing	3.2	2.80	2.35
Mixed	2.5	2.57	2.33
Residential	2.19	1.9	1.9
Rural	2.10	2.69	3.39

Note (1) the varying incidence and the decreasing rates from above downwards in columns 1 and 2; (2) the lower rate in column 3 for the upper three districts; (3) the fixed rate in column 3 for residential districts; (4) the increased rate in column 3 for rural districts; and observe that the three upper districts are those likely to be affected by withdrawal of industrial workers, and hence to experience a decrease of industrial accidents.

Further, is it a coincidence that I can prove the attack rate per 1,000 births was 2.35 in the period 1915-18, and 3.08 in the previous five years? Or, again, that a four months' strike in the cotton trade in 1910 coincided with a puerperal rate for that year lower than for any year since the Midwives Act—a fact which induced undue optimism in the mind of the M.O.H. for Lancashire, rudely shattered by the statistics of the succeeding four years.

Can any of your readers suggest any other explanation of these facts?

I may be puffed up by statistics, but am prepared to be let down by reason. I must refrain from answering Dr. C. M. Stevenson at length, and also from wearying your readers by statistics showing the relative responsibility of doctors and midwives.—I am, etc.,

Heywood, Lanes, May 21st.

GEORGE GEDDES.

SIR,—Dr. Vaughan Pendred speaks of an experience of twenty-seven years. Alas! I can quote a longer one. Time has taught me the value of gloves and a sterile jacket. The former are more readily washed in soap and water or soaked in perchloride if by chance the hands have touched any unclean thing of the patient or surroundings.

Mercury biiodide roughens the hands and in time renders them difficult to maintain clean; in the winter antiseptics are often self-destroying.

I would say soap and water, boiled rubber gloves and a sterile jacket, the avoidance of lubricants and "meddlesome midwifery," including the odd examinations by maternity nurses, will not introduce sepsis, and if not introduced it will not want dealing with by strong antiseptics.

Much of my work is major and minor surgery; I carry out in midwifery practice the technique so far as possible of the operating table.

Antiseptics are a snare to the careless; the use of soap and water and sterile rubber gloves are a definite double event which can only do good if merely by shutting off our finger nails.

In the individual case the causation of puerperal infection may be within or without the patient.—I am, etc.,

Dorchester, May 29th.

W. B. COSENS.

REFRACTION WORK IN CHILDREN.

SIR,—Any Education Committee which expects its medical officer to complete six cases in an hour must also expect to have the work scamped and unsatisfactory results exhibited; on the other hand, somewhat more than three cases done with care and accuracy must be expected at the hands of every refractionist. I have been engaged in this work for a period extending over seventeen years and comprising such a number of cases as has passed into thousands, and am able to say that nine cases in a session of two hours is an average and that subjective methods must be combined with retinoscopy—in fact, where any reliance can be placed upon the information obtained from the subject, the subject must have the last word. In many clinics where too much work is demanded, and only objective methods are practised, a large number of the children in various ways express discomfort; especially is this so among hyperopes where over-correction almost appears to be the rule; such children return again and again for re-examination, so that while the number of attendances is a maximum the number of cases satisfactorily disposed of is a minimum; or many such children seek the assistance of opticians who, founding their subjective test upon a measurement of the glasses in question, are often, very often, able to remove that discomfort which ought never to have existed. In the case of very young children and those of defective mental capacity or interpretation, only objective methods can be practised, but surely these should be the exception and not the rule.—I am, etc.,

London, W., May 30th.

H. G. CRITCHLEY, M.D., D.P.H.

DEFECTS IN TUBERCULOSIS ADMINISTRATION.

SIR.—Your leading article (BRITISH MEDICAL JOURNAL, May 7th, 1921, p. 678) on the new tuberculosis regulations brings into prominence one of the great defects in the organization of the public health service—namely, the haphazard division of work between the county medical officer of health and the medical officer of health for a district within the county. Assuming for the moment that both kinds of health officers are necessary, surely the work should be so apportioned that each has a definite and appropriate share and the natural division is local work for the local man, provincial work for the provincial man.

Let us see how far this applies to the tuberculosis scheme. In the first instance, the general practitioner is required to notify every fresh case of tuberculosis coming to his knowledge to the medical officer of health for the district where the patient resides. It is the duty of that medical officer to see that notification is duly carried out, to keep trace of the patient as he moves within or out of the district, or enters or leaves an institution, or dies; but, apart from attending to any insanitary conditions which may affect the patient or the spread of infection, the local medical officer of health has no further concern with the case, nor is he in a position to render any effective service. The formal information which he has collected is passed on in a weekly return to the county medical officer of health, who in turn directs the work of the tuberculosis officer (and nurse) under whose supervision the patient remains. There is, unfortunately, no reciprocity between the tuberculosis officer who looks after the person of the patient and the local medical officer of health who looks after his surroundings.

Clearly all local work comprised in the term "domiciliary treatment" should be done under the eye of the local medical officer of health, and the sanatorium treatment, which rests on a larger basis, would be properly left entirely in the hands of the county medical officer, while the position of the tuberculosis officer between the two might be roughly compared to that of a liaison officer. One can hardly imagine a more inconvenient and uneconomical arrangement than that which at present exists in regard to bringing tuberculosis officer and patient into contact, for the earliest the former can hear of a new case is through the local medical officer of health and the county medical officer of health, after a delay of any time up to a week! On the other hand, neither the tuberculosis officer nor the county medical officer can deal with the patient's environment—for example, overcrowding, defective sanitation, etc., except through the local medical officer of health. For all local matters at least no great harm would result if the county medical officer of health were cut out of the circuit, and the way by which this could be effected was clearly indicated in the Regulations of 1912, referred to in your leader.

The inconsistency, so apparent in this rough and ready division of work, leads to a great deal of confusion and, naturally, at times, to no small amount of friction between county and district medical officers of health. The remedy would not be difficult to find if those who have actual experience of the work and its peculiar problems were consulted, while, by a revision and consolidation of the numerous scraggy Orders and Regulations now in existence, the whole matter could be quickly settled.—I am, etc.,

May 15th.

MIXTURE.

THE first of a series of three new buildings for the University of Manitoba is nearly completed, and will provide accommodation for the departments of biochemistry, bacteriology, and physiology, with provision for laboratories, lecture rooms, museums, and departmental libraries.

THE records of the New York Health Department show that for the first fourteen weeks of 1921 the infant mortality rate was 80 per 1,000 children born, as against 112 for the corresponding period of last year. In commenting upon this reduction, which represents a saving of 1,132 infant lives, the Health Department suggests the possibility that the mild winter, which resulted in better ventilation of premises and in children being out of doors a greater part of the time, may have been a factor, and also that better food, better clothing, and the more general dissemination of information in regard to hygiene may be responsible.

Obituary.

RICHARD EUGENE HARCOURT, M.D., F.R.C.S.,
Ophthalmic Surgeon, Bootle Borough Hospital.

DR. HARCOURT, who died at his residence in Oakfield Park, Liverpool, on May 19th, was born in 1858 at New Jersey, U.S.A. His father was a native of County Down, Ireland, and his mother an American lady of Dutch extraction. Harcourt spent his school life partly at Newry and partly at the Liverpool Institute. He received his medical education at Queen's College, Belfast, and graduated in 1887. He remained a keen student all his life, as is shown by the post-graduate degrees which he acquired—the M.D. and B.A.O. of the Royal University of Ireland in 1893, the M.D., M.S. Uruguay in 1893, and finally the F.R.C.S., England in 1907. After a period of service under Mr. (now Sir) Robert Jones at the Royal Southern Hospital and at one of the Manchester Ship Canal hospitals, Harcourt went to Buenos Aires, where he practised for ten years and was medical officer to the Buenos Aires port works and to the Government police at Las Conchillas. He returned to England in 1898, and after a short spell of practice at Warrington settled down in Wavertree, Liverpool. He retired from general practice about ten years ago and devoted himself to ophthalmology, being appointed pathologist to the Liverpool Eye and Ear Infirmary; later he became also assistant surgeon to this hospital and ophthalmic surgeon to the Bootle Borough Hospital and assistant ophthalmic surgeon to the St. Helens Hospital. His excellent pathological work secured for him a lectureship in ophthalmic pathology at the University of Liverpool. During the war he gave invaluable assistance to the depleted staff of the St. Paul's Eye Hospital. To all this work and to an increasing private ophthalmic practice Dr. Harcourt added a large amount of ophthalmic school work for the Bootle and Liverpool education authorities, industrial schools, and for the Roman Catholic school committees.

There can be but little doubt that overwork was one of the contributory causes of his last illness. He had suffered from dysentery while abroad, and recurrences of this trouble were not infrequent. About a year ago he became anæmic, and this affection turned out to be of the "pernicious" type; transfusion (thrice repeated) and all the remedies that the physician and bacteriologist could devise were applied without avail. During a temporary improvement in his health last autumn Harcourt returned to full work, to which he clung pathetically, only to be forced to relinquish reluctantly duty after duty.

With the exception of reading and his social and family duties Harcourt's relaxation consisted simply of change of work. Though he began to specialize as an ophthalmic surgeon late in life, he was a good operator, and his wide reading and full knowledge of general surgery and pathology made him a thoroughly sound practitioner and a successful and inspiring teacher. Dr. Harcourt was a member of the Liverpool Medical Institution, where he frequently showed patients and pathological specimens, was one of the original members of the North of England Ophthalmological Society, and a member of the British Medical Association. He was an ardent Freemason and an active supporter of the Wesleyan Church.

As a man and colleague Harcourt was genial, kind and loyal, ever young and progressive; if he had a fault it was that he spoilt his colleagues by his good-natured readiness to help them when they were lazy or tired, ill, or overworked. Dr. Harcourt is survived by his wife, two sons, and three daughters.

DR. ARTHUR SNEYD TAYLOR, of Surbiton, who died on April 7th after two days' illness, was born in 1859 and educated at Merchant Taylors' School, where he won a mathematical scholarship and proceeded to Pembroke College, Cambridge. He graduated B.A. in the mathematical tripos in 1882. He then entered Guy's Hospital and took the diploma of M.R.C.S. in 1886 and the Fellowship two years later, and graduated M.B., B.Ch. Camb. in 1887 and M.D. in 1893. He was surgeon to the Surbiton Cottage Hospital. Dr. Taylor was a noted Rugby footballer. He represented Cambridge, Guy's, and Blackheath in the eighties; played for the South against the North and for England against Wales in 1882. He played again

for England in 1883 and in 1885-86. During the war he was temporary Captain, R.A.M.C.(V.), and took an active part in the work of the Kingston-Surbiton District Red Cross Hospital and of the Oakenshaw War Hospital. On his retirement in March, 1920, he was granted the honorary rank of captain. He was a member of the Kingston Division of the British Medical Association.

Universities and Colleges.

UNIVERSITY OF LONDON.

The following candidates have been approved at the examination indicated:

TURN M.B., B.S.—†§C. H. Andrewes (University Medal), †Florence R. Clulow, †H. A. Harris, †R. C. B. Ledlie, *A. G. Maitland-Jones, †V. E. Negus, *P. Steinberg, Doris E. Alcock, G. C. Agarwala, W. M. Anthony, J. R. Banks, Mary R. Barkas, F. M. Barnes, H. E. Beasley, Ursula P. Blackwell, H. J. Blampied, J. Brodie, P. C. P. Cloake, E. V. Corry, Elsie E. Cowperthwaite, J. L. ap I. Davies, A. G. Duncan, Edith M. Evans, Ada M. Freeman, I. Frost, Madeline Giles, F. Heber, J. G. Jones, Dorothy M. Kemp, Mary K. F. Lander, E. H. L. Leclizio, H. W. Lewis, R. T. Lewis, Margaret Longbottom, E. R. Lovell, G. J. W. McMichael, Henrietta A. C. Main, C. H. Marshall, Adeline M. Matland, Kathleen H. Matthews, Sybil M. Nuttall, Sybil G. Overton, R. H. Parry, Phoebe M. Phillips, Alice D. Pocock, W. R. Rowlands, G. W. R. Rudkin, H. L. Sackett, A. Shafeek, B. B. Sharp, Katherine J. Shaw, L. F. Sirmannell, R. N. L. Symes, R. S. Tirodkar, Norah E. Trouton, A. E. Ward, S. A. T. Ware, R. W. Warrick, F. W. A. Watt, Agnes E. Westwood, I. G. Williams, W. P. Wippell, W. C. S. Wood.

Distinguished in * Medicine, † Pathology, ‡ Forensic Medicine, § Surgery.

UNIVERSITY OF BRISTOL.

The University Council at its meeting on May 27th received the resignation of the Vice-Chancellor, Sir Isambard Owen, M.D., who, having reached the age of 70, is due to retire under the operation of the Treasury new rules with regard to superannuation. The resignation takes effect at the end of the present session. Sir Isambard Owen, who went to Bristol in 1909 in succession to Professor Lloyd Morgan, is responsible for practically the whole of the organization of the University.

SOCIETY OF APOTHECARIES OF LONDON.

The following candidates have passed in the subjects indicated:

SURGERY.—*E. D. Fenwick, *H. L. Sheehan, †J. Solomonoff.
MEDICINE.—†F. E. Edwards, †M. A. K. El. Hennawy, *†E. D. Fenwick, *†O. E. Finch, *A. Mishriky, H. L. Sheehan.
FORENSIC MEDICINE.—F. E. Edwards, M. A. K. El. Hennawy, E. D. Fenwick, O. E. Finch, H. L. Sheehan, M. Tcherny, N. E. Williams.
MIDWIFERY.—M. A. K. El. Hennawy, E. D. Fenwick, M. Fox, A. Senn, H. L. Sheehan.

*Section I.

†Section II.

The diploma of the Society has been granted to Messrs. E. D. Fenwick and J. Solomonoff.

The Services.

DEATHS IN THE SERVICES.

SURGEON-MAJOR HENRY COOKSON, Bengal Medical Service (retired), died at Cheltenham on April 22nd, aged 88. He was born on February 10th, 1833, the son of Mr. Thomas Henry Cookson of Boston, and was educated at Edinburgh University, Leeds, and St. Thomas's Hospital. He took the M.R.C.S. in 1856, and entered the Royal Navy as assistant surgeon in the same year, but resigned with less than three years' service. In 1859 he took the L.R.C.P. Edin., and entered the I.M.S. on January 20th, 1860, attaining the rank of surgeon-major on July 1st, 1873, and retiring on May 20th, 1880. He also took the F.R.C.S. Eng. in 1870, and the D.P.H., after retirement, in 1882. He served on the North-West Frontier of India in the Jowaki campaign of 1877-78, when he was mentioned in despatches, in G.O.O. No. 738 of 1878, and received the frontier medal; and in the second Afghan war of 1878-79, when he took part in the capture of Ali Musjid, was again mentioned in despatches, in G.O.C.C. of October 14th, 1879, and received the medal with a clasp.

Fleet Surgeon Anthony Kidd, R.N. (retired), died on April 24th at Bath. He was educated at the Ledwich School, Dublin, and took the L.R.C.S.I. in 1879 and the L.K.Q.C.P. in 1880; he entered the navy and attained the rank of fleet surgeon on February 26th, 1897. Before his retirement he was serving as principal medical officer at Penbrooke Dock, and afterwards filled the post of surgeon and agent at Falmouth; subsequently he practised at Bath.

Lieut.-General Sir Lancelotte Gubbins, K.C.B., formerly Director-General A.M.S., has been reappointed a Special Commissioner of the Royal Hospital, Chelsea.

Medical News.

THE following committee has been appointed by the Minister of Pensions to inquire into the management by the Ministry of Pensions and the Joint Disablement Committee for the South-West of Scotland, of Bellahouston Hospital, and especially the organization of the out-patient department: The Right Hon. Lord Scott Dickson, P.C., K.C. (chairman), Sir Donald MacAlister, K.C.B., president of the General Medical Council, Mr. W. Grieve, a disabled soldier, and Colonel Sir Arthur L. A. Webb, K.B.E., C.B., Director-General of Medical Services, Ministry of Pensions.

THE annual dinner of the Indian Medical Service will be held at the Trocadero on Wednesday, June 15th, Major-General Sir R. Havelock Charles, G.C.V.O., in the chair. Tickets and all particulars may be obtained from the joint honorary secretary, Colonel J. J. Pratt, I.M.S.(ret.), 63, Addison Road, Kensington, W.14.

THE Cavendish lecture, followed by the annual conversation of the West London Medico-Chirurgical Society, will be delivered at the Kensington Town Hall by the Right Hon. Christopher Addison, M.D., M.P., on Friday, June 17th, at 8.15 p.m. The subject of the lecture will be "The part of the State in the prevention of disease." A reception will be held at 7.45 p.m. Members requiring tickets for guests are asked to communicate as early as possible with the Hon. Secretary, Dr. D. G. Rice-Oxley, M.C., 22, Victoria Road, W.8.

COMMEMORATION DAY took place on May 27th at Livingstone College, London, E., when many friends of foreign missions were present at a gathering presided over by Sir George Makins, who said that it was necessary that the missionary, to fulfil his aim, should have, in addition to his theological training, some knowledge of medical things. He remarked on the great value in the mission field of the partial medical training which was obtained at Livingstone College. The value of this training was further emphasized by the personal experiences related by Dr. G. E. King, of the China Inland Mission, and the Rev. L. Taylor of the Moravian Mission, Nicaragua.

A SESSIONAL meeting of the Royal Sanitary Institute will be held on June 9th and 10th, in the Guildhall, Gloucester, jointly with the West of England Branch of the Society of Medical Officers of Health. On June 9th at 10 a.m. a discussion on "Public health development in Gloucestershire" will be opened by Dr. J. Middleton Martin, County M.O.H. Gloucestershire. On June 10th, at 10 a.m., there will be a discussion on "The collection and disposal of house refuse." The chair will be taken by Professor H. R. Kenwood.

THE annual general meeting of the Governors of Epsom College will be held at the offices, 49, Bedford Square, W.C.1, on Friday, June 24th, at 4 p.m.

ON May 14th the 125th anniversary of the first vaccination performed by Edward Jenner was celebrated in the ball of Leyden University by the Dutch Society for the History of Medicine and Natural Philosophy. Addresses were given by Professor E. C. Van Leersum and Mr. C. J. S. Thompson, Curator of the Wellcome Museum.

A QUESTION was recently addressed in the House of Commons by Mr. Robert Young, M.P., to the President of the Board of Education on the subject of whether the earlier hours of attendance and the consequently prolonged day due to the operation of the Daylight Saving Act had had any injurious effect on the health of young children. A circular has been sent to local education authorities by the medical department of the Board of Education asking than an endeavour should be made to ascertain through school medical officers and teachers the effect during the current year of the Summer Time Act on the health of school children, and on their proper attention to school work.

A MEDICAL congress will be held at Helsingfors from June 30th to July 2nd. The principal subject to be discussed is the treatment of syphilis—(a) of the central nervous system, and (b) of the thoracic and abdominal viscera.

THE next course of international post-graduate lectures in Vienna will begin on June 6th. Full particulars can be obtained from the Dean of the Medical Faculty at the University, Franzensring, Vienna I. The course will consist of lectures, by professors of the Medical Faculty, on recent advances in surgery, orthopaedics, gynaecology, and pediatrics.

THE annual meeting of the British Science Guild will be held at the Goldsmiths' Hall, Foster Lane, London, on Wednesday next, June 8th, at 3 p.m., when Dean Inge will speak on "The road to ruin and the way out." and Sir Richard Redmayne will give an address on the importance of research in promoting the development of mineral industries.

THE annual dinner of the Harveian Society of London will be held at the Café Royal, Regent Street, on Wednesday, June 22nd, at 7.30 p.m.

ON the occasion of the departure of Dr. D. A. Powell from the district to become superintendent of the Welsh Sanatorium at Denbigh, the medical practitioners of Anglesey entertained him to a very successful dinner, held on May 13th, as a mark of esteem and of the cordial relations that had existed between Dr. Powell, as tuberculous physician to the Welsh National Memorial, and the practitioners of the district.

THE second annual general meeting of the Society for the Prevention of Venereal Disease will be held at 5.30 p.m. on Monday, June 6th, at the Barnes Hall, 1, Wimpole Street (kindly lent by the Royal Society of Medicine).

AS already announced, the annual provincial meeting of the Society of Medical Officers of Health will be held on Saturday, June 11th. Owing to a printer's error in the notice sent to members, we are asked again to draw attention to the date.

THE June number of the *New York Medical Review of Reviews* will be a special radium number dedicated to Madame Curie, and will consist exclusively of articles on radium and its uses by the most prominent radiologists in the United States and Canada.

THE fifty-second annual meeting of the Canadian Medical Association is announced to take place at Halifax, Nova Scotia, from July 5th to 8th, under the presidency of Dr. Murdoch Chisholm.

AS a step in the reconstruction plans of Yale University the subjects of pharmacology and experimental medicine have been combined into a university department with the title of the Department of Pharmacology and Toxicology. Special attention is to be devoted to the training of future investigators and teachers, and to the chemistry and physiology of the action of drugs and poisons.

ACCORDING to the *Journal of the American Medical Association*, an unusual situation has been brought about in the Johns Hopkins Medical School and the Johns Hopkins Hospital by the resignation of Dr. William S. Thayer, professor of medicine in the medical school and physician-in-chief of the hospital, who was chief medical adviser of the American Expeditionary Force during the war. The seventy physicians connected with the department of clinical medicine have offered their resignations in response to a circular letter sent out by the medical board of the hospital. This letter explained that none of the members of the department would be reappointed prior to the selection of the successor to Dr. Thayer. This course was taken in order that the new professor of medicine and physician-in-chief of the hospital might have a free hand in reorganizing his department and carrying out the policy involved in the idea of a full-time professorship.

IN addition to the post-graduate courses in medicine at the Hôtel-Dieu already noted in the JOURNAL, a number of other vacation courses will be given in Paris during this summer and autumn. At the Hôtel-Dieu, from July 1st to 31st, there will be a course on diseases of the digestive tract and the biliary ducts, by Professor Hartmann and others, and at the Salpêtrière Hospital, from June 27th to July 11th, a post-graduate course on surgical technique, including practical work, by Professor Gosset, assisted by Dr. G. Loewy and others; this latter course will be conducted in English, and will be limited to twenty medical men. At the Hôpital de la Pitié, from June 20th to July 10th, a course on diseases of the heart, blood-vessels, and blood will be given by Professor Vaquez and others, and at the Hôpital des Enfants Malades, from August 17th to September 3rd, a course on diseases of children has been arranged by Professor Noddeur. At the Broca Hospital, from September 19th to October 1st, a course on gynaecology will be given by Professor J. L. Faure and his colleagues. In the histological laboratory of the faculty of medicine there will be during the month of October a course on histology, by Professor Penant, and in the pathological laboratory, from October 5th to 30th, a course on pathology by Professor Letulle. At the Hôpital Laënnec and other three hospitals in conjunction, from July 4th to 17th, a course on tuberculosis will be carried on by Professors Léon Bernard, Bezançon, Auguste Broca, Letulle, and Renon, and in the laboratory of the faculty,

from July 1st to 12th, a course on parasitology will be given by Professor Brumpt. At the School of Child Welfare, 64, Rue Desnouettes, Paris (XV^e), from October 3rd to 13th, a series of lectures on child welfare, with visits to the Parisian municipal centres, has been arranged by Professor A. Pinard and others; further information on this course may be obtained, before September 25th, from M. Weisweiler, administrator of the school. In regard to all the other courses particulars will be given by the Secretary of the Faculty of Medicine of Paris, to whom application should be made, before June 15th, in the case of courses before the month of August, and before July 15th, in the later courses. The fees range from 50 francs, for the child welfare course, to 80 francs for the courses on histology and pathology, and 150 francs for the clinical courses. Information regarding such matters as travel and accommodation will be given by the Association for the Development of Medical Relations, at the Faculty of Medicine of Paris.

THE University College Hospital Ladies' Association, founded some twenty years ago to provide clothes for patients in the wards and to help patients when discharged, has now some eight hundred members and ten local branches; it maintains two beds and its junior branch a cot. Its latest work has been the establishment of an infant welfare department. The hospital is in financial difficulties, and the Ladies' Association will hold a sale on June 8th at Someries House, Regent's Park, the residence of Major Harold and Lady Zia Wemher. The sale will be opened by Princess Helena Victoria at 11.30 a.m.

SIR KENNETH W. GOADBY, K.B.E., M.R.C.S., lecturer on bacteriology at the National Dental Hospital, has been appointed to represent medical science on the Advisory Committee for the Metalliferous Mining Industry.

MESSRS. A. W. GAMAGE, of Holborn, E.C.1, have issued a new catalogue containing particulars, with prices, of a very large number of motor accessories.

Letters, Notes, and Answers.

As, owing to printing difficulties, the JOURNAL must be sent to press earlier than hitherto, it is essential that communications intended for the current issue should be received by the first post on Tuesday, and lengthy documents on Monday.

ORIGINAL ARTICLES and LETTERS forwarded for publication are understood to be offered to the BRITISH MEDICAL JOURNAL alone unless the contrary be stated.

CORRESPONDENTS who wish notice to be taken of their communications should authenticate them with their names—of course not necessarily for publication.

AUTHORS desiring reprints of their articles published in the BRITISH MEDICAL JOURNAL are requested to communicate with the Office, 429, Strand, W.C.2, on receipt of proof.

IN order to avoid delay, it is particularly requested that ALL letters on the editorial business of the JOURNAL be addressed to the Editor at the Office of the JOURNAL.

THE postal address of the BRITISH MEDICAL ASSOCIATION and BRITISH MEDICAL JOURNAL is 429, Strand, London, W.C.2. The telegraphic addresses are:

1. EDITOR of the BRITISH MEDICAL JOURNAL, *Aitology*, Westrand, London; telephone, 2630, Gerrard.

2. FINANCIAL SECRETARY AND BUSINESS MANAGER (Advertisements, etc.), *Articulate*, Westrand, London; telephone, 2630, Gerrard.

3. MEDICAL SECRETARY, *Medisecra*, Westrand, London; telephone, 2630, Gerrard. The address of the Irish Office of the British Medical Association is 16, South Frederick Street, Dublin (telegrams: *Bacillus*, Dublin; telephone, 4737, Dublin), and of the Scottish Office, 6, Rutland Square, Edinburgh (telegrams: *Associate Edinburgh*; telephone, 4361, Central).

QUERIES AND ANSWERS.

DIACETIC ACID TESTS.

"F. E." Orange Tree State writes: I should be glad to know of a method of detecting diacetic acid in the stains of a baby's napkin. I find that lint damped with normal urine to which diacetic acid has been added does not give the purple reaction with ferric chloride solution as one would expect.

Diacetic acid and acetone, being volatile substances, cannot be detected by any test in a stain on a napkin. The only way would be to test the fresh expressed urine with the nitro-prusside test this is best done as a ring test, which shows both acetone and diacetic acid. The blood can also be examined for acetone, and the carbon dioxide content of the alveolar air determined to show acidosis.

INCOME TAX.

"T. G." bought out his senior partner on January 1st, 1920. He asks whether he can deduct as an expense in calculating his income tax return that portion of the gross receipts which

is handed over to the retired partner as being his share of fees earned prior to the dissolution.

No; our correspondent is now liable to payment of tax on the whole of the practice profits. Strictly he is entitled to base his gross receipts on bookings, but if he prefers to take the cash takings basis, then all the takings which relate to the practice must be brought into the computation.

"S. B." inquires as to the proper basis of assessment in view of the fact that he purchased a practice on January 1st, 1920.

For 1920-21 "S. B." is chargeable on the amount of the average profits of the practice over the three years to December 31st, 1919, and for 1921-22 on the three years' average to December 31st, 1920. In each case the average is reducible to the profit of the current calendar year if a specific cause for the reduction can be shown. Presumably the advice of the local inspector was given on the assumption that "S. B." was not in a position to ascertain his predecessors' profits for the purpose of average. In calculating the "profits" for the early years of his own work, "S. B." must take into account fees receivable but not actually to hand.

"L. T.'s" car transactions have been as follows:

	£	s.	d.
1910. Secondhand Allday bought for ...	100	0	0
1911. Secondhand Allday sold for ...	50	0	0
New De Dion bought for ...	289	0	0
1913. New Ford bought for ...	138	0	0
1919. De Dion sold for ...	25	0	0
1920. Ford sold for ...	57	10	0
Secondhand Ford bought for ...	230	0	0

*. Our correspondent can claim the cost of renewing his Ford car (£230-£57 10s.=£172 10s.) as an expense. Further, if he again buys a secondhand car and maintains it at the same time as the Ford, he can bring in as an expense the loss on the De Dion—that is, £289-£25=£264.

PARATYPHOID FEVER.

"F. Z. O."—The references to paratyphoid fever are scattered, and consist, for the most part, of short articles in medical journals. *Typhoid Fevers and Paratyphoid Fevers*, by Vincent and Muratet, one of the series of French military medical manuals, has been translated by Dr. J. D. Rolleston (University of London Press, 1917. Price 7s. 6d.). Dr. Charles Miller's Goulstonian Lectures in 1917 were on paratyphoid infections. An earlier account of the clinical features of paratyphoid fever was given by Torrens and Whittington in the BRITISH MEDICAL JOURNAL of November 13th, 1915.

LETTERS, NOTES, ETC.

HYGIENE OF SEAMEN.

COLONEL G. F. ROWCROFT, M.R.C.S., L.R.C.P. (U.P., India) writes: In your note on "Hygiene of Seamen" in the BRITISH MEDICAL JOURNAL for April 9th, just received by me, it is suggested (p. 538) that the rate of mortality for European (not British) seamen is lower than that in land-going industrial life. Possibly so, for to our discredit many foreign ships have infinitely better accommodation for their seamen than most of our British lines (I refer to the Mercantile Marine only), and they therefore lower the percentage of disease, etc. There are a few, very few, praiseworthy English exceptions. Unfortunately, I cannot now refer to figures, but taking British (not European) seamen, in the case of tuberculosis the percentage has been shown to be far higher than for landmen, due solely to the iniquitous accommodation provided. Incidentally, though it has not to do with this matter exactly, it may be noted that the mortality due to "accidents" mostly largely preventable, but favoured by the policy of unscrupulous owners—is far higher among British seamen than in any land trade. The suggestion that encroachment on ship space in favour of more room for the accommodation of crews might ruin the industry is countered by the fact that a few British lines do it, as well as some foreign ones, as already mentioned.

HERPES ZOSTER AND VARICELLA.

DR. ARTHUR SOMERS (Selby, Yorks) writes: Owing to the recently established connexion between herpes zoster and varicella the following may be of interest: On May 7th this year I was asked to see a boy aged 2 years. On examination I found that he was suffering from varicella, the eruption being most copious on the trunk and scalp. Before leaving the house the boy's mother informed me that her other boy, aged 9 years, had been sent home from school on April 26th by the school medical officer, who stated in his report that the boy was suffering from shingles. On examination I found a typical eruption on the left side of the thorax. It is, I think, worth observing that in these cases the time between the diagnosis of herpes and that of the appearance of the rash of varicella was eleven days, the incubation period of varicella being generally given as from ten to fifteen days.

NELD FOR POST-GRADUATE INSTRUCTION IN MOUTH SEPSIS.

"A. B. C." writes: "I am dental surgeon to a hospital, and to its attached school. A syllabus has been issued by the school giving a time-table for a special post-graduate vacation course. In this list no mention is made of teaching the evils of mouth sepsis—either its diagnosis, diseases which arise from it, or its treatment. I have had a correspondence about this with the dean of the medical school. Perhaps mouth sepsis, and the results of mouth sepsis, assume an undue importance in my eyes. It may be receiving all the attention it deserves, but this is a question I would like your readers to determine. Personally, I cannot see how a post-graduate course of teaching in medicine can be said to be complete without this subject being carefully and fully dealt with. In the letters to which I have referred my correspondent realizes this subject should be given some attention. The time-table now being complete, it would seem just possible to get an hour's demonstration in on one morning at 9 o'clock. Whilst most of us would agree that this subject deserves some attention, what I really want to know is, is it important enough to be put in, if necessary, to the exclusion of some of the less-needed teaching which I consider the syllabus allows for? It would be invidious to mention any particular teaching, but there is a long list. For some time past medical literature has been calling attention to the many ailments that can originate from mouth sepsis. Most medical practitioners are fully alive to the importance of this—the commonest of pathological changes in the body. Now the question is, How can he best examine for this in the mouth, how does he set about it, and having established a connexion between it and the trouble he is called upon to treat, what is his next step? He should know to what extent mouth sepsis is remedial—that is, that there are other methods than to take out all the teeth. If I am right in this, is not the dental surgeon the best man to show him?"

*. The nature of the correspondence is sufficiently indicated in the letter printed. "A. B. C." suggested to the Dean that in the light of the influence of mouth sepsis on general ailments some use should be made of the dental department in the post-graduate course. The Dean replied that the difficulty was not to find subjects to talk about, but sufficient time to accommodate all those who wished to take part in the course. "A. B. C." replied that a knowledge of the troubles to which mouth sepsis gives rise is of daily increasing importance to general practitioners, so that the subject deserved a place in any post-graduate course. To this the Dean replied asking "A. B. C." to suggest a time for a demonstration of mouth sepsis in relation to diseases in other parts.

"THE BUFF BOOK."

DR. BASIL E. MOSS (Edmonton) writes: Following on the publication in last week's issue of the BRITISH MEDICAL JOURNAL (SUPPLEMENT, p. 197) of some rather caustic remarks as to the inclusion of the names of various medical men in the "Buff Book" issued by The Business Telephone Directories, Ltd., my attention was drawn to the fact that my own name appeared in this list. I hasten to write to you to point out that I had nothing whatever to do with this. The inclusion of my name in this way was quite without my knowledge or consent (and I have reason to believe that this is the case with several other men whose names appear in the same list). I have written to The Business Telephone Directories, Ltd., protesting against the inclusion of my name in this way, and demanding that it be withdrawn from any further editions of their publication.

VACANCIES.

NOTIFICATIONS of offices vacant in universities, medical colleges, and of vacant resident and other appointments at hospitals, will be found at pages 33, 34, 35, 36, 37, 40, and 44 of our advertisement columns, and advertisements as to partnerships, assistantships, and locum tenencies at pages 38, 39, and 40.

THE appointment of certifying factory surgeon at Walton-on-Naze (Essex) is vacant.

SCALE OF CHARGES FOR ADVERTISEMENTS IN THE BRITISH MEDICAL JOURNAL.

	£	s.	d.
Six lines and under ...	0	9	0
Each additional line ...	0	1	6
Whole single column (three columns to page) ...	7	10	0
Half single column ...	3	15	0
Half page ...	10	0	0
Whole page ...	20	0	0

An average line contains six words.

All remittances by Post Office Orders must be made payable to the British Medical Association at the General Post Office, London. No responsibility will be accepted for any such remittance not so safeguarded.

Advertisements should be delivered, addressed to the Manager, 429, Strand, London, not later than the first post on Tuesday morning preceding publication, and, if not paid for at the time, should be accompanied by a reference.

NOTE.—It is against the rules of the Post Office to receive *post restante* letters addressed either in initials or numbers.

A Post-Graduate Lecture

ON

LIMPS IN CHILDREN:

THEIR RECOGNITION, ORIGIN, AND TREATMENT.

BY

JOHN FRASER, M.D., F.R.C.S.,

SURGEON TO THE ROYAL HOSPITAL FOR SICK CHILDREN; ASSISTANT
SURGEON, ROYAL INFIRMARY, EDINBURGH.

PERHAPS I ought to apologize for dealing with a subject which the orthopaedist has come to regard as his own, but I am going to make no apology, because I speak from the point of view of the general surgeon—of one who has to spend much of his time in the wards of a children's hospital, and who is constantly experiencing the practical difficulties of which I speak.

In discussing the subject I shall attempt to illustrate certain distinctive limps by means of cinematograph pictures, a method of illustration which we are finding of increasing value in teaching the student, and also (if I may say so) of humbling the surgeon. The average surgeon is notoriously an optimist—I suppose his work makes him such, for someone has said that where there is no faith there can be no surgery. But, nevertheless, I am afraid that many of our surgical results are seen through rose-coloured spectacles. We forget the original picture, and we take too much credit for our post-operative results. A pre-operation film is an excellent corrective!

The Importance of Recognizing and of Investigating a Limp.

We have all had the experience of being asked to see a child because it is limping, and I know few more difficult problems than that of definitely localizing the site and the origin of the disorder. The younger the patient the more difficult does the problem become. He may be able to give us no assistance, and frequently he is actively antagonistic; the story of the parents may be garbled or actually misleading, and in many cases the elucidation of the mystery depends entirely on the clinical acumen and the trained observation of the examiner.

It is certain that the average parent has no sympathy with the doctor if he is unsuccessful in solving the mystery, or if he makes a mistake in diagnosis. To their minds the problem should present no difficulties, and therefore they make no excuse for error; but, as I have said, and as I shall attempt to show, few more difficult problems come under the notice of the specialist or general practitioner.

It is obviously essential that the origin and nature of the limp should be determined before adequate treatment can be carried out. Purely empirical treatment is rarely successful.

There is yet another reason why one urges the early and thorough investigation of a limp, and, though I mention it last, it is, from the practical point of view, the most important—early recognition and definition spells early treatment, and the pathology of many limps is of such a nature that early treatment means a good result, while delay may entail functional disaster.

A General Consideration of the Possible Causes of a Limp in a Child.

When a limping child is brought to notice and one is asked to furnish the diagnosis, I believe that it is a good plan to consider the problem from a logical standpoint—to say to oneself that there are certain groups into which limps may be classified. It is the first duty of the observer to recognize into which class the case falls. Having decided this more general consideration, it naturally becomes an easier matter to explore the various possibilities of the larger group, and to conclude with a local and exact diagnosis. We shall see the application of my argument in a moment when I have elaborated a scheme of classification.

Classification of Limps from the General Point of View.

This question of the general scheme of classification of limps is by no means as easy as it might appear. As far as I know, the question is not specifically considered from

this point of view by either the orthopaedist or the general surgeon, but it seems to me that there are certain general classes of limps, and when a limping child is brought to me for an opinion, the first thing I do is to attempt to put the limp into its general class. What are these general classes? I would venture to suggest that they may be tabulated as follows—and of course there is nothing original about the classification—it is merely common sense:

- I. Functional limps.
- II. Painful limps.
- III. Flaccid limps.
- IV. Spastic limps.
- V. Mechanical limps.
- VI. Stiff limps.

Let me in a few words explain what I mean by these relative terms.

Functional limp is rare in children, especially in the early years of life. If met with, it is generally found in girls over the age of 8 or 9 years. It has certain characteristics of stiffness, of variation in degree and of exaggerated symptoms unaccompanied by any discoverable lesion. It forms a distinctive class of limp, as I shall attempt to show, but its diagnosis must only be made after the careful exclusion of other possibilities.

Painful limp, or the "hurrying limp," as it is sometimes called, has as its essential feature the reduction to a minimum of weight-bearing on the limb. The source of the pain may vary from a blister of the foot-sole to an acute infection of the hip-joint. The degree of limp will be modified according to the situation and degree of the pain.

Flaccid limps. Under this term I include those gaits in which the distinctive feature is muscular weakness, from whatever cause it may proceed, whether the central nervous system, the peripheral nerves, or the muscles. The possible origin may have such varying sources as poliomyelitis, a peripheral nerve lesion, or a muscular dystrophy.

Spastic limps are generally characteristic, and there is rarely any difficulty in their recognition. The picture of the stiff and jerking gait is so distinctive that once seen the impression remains. Almost without exception they are the result of an error—congenital, inflammatory, or traumatic—of the central nervous system.

Mechanical limps. It is with this variety that I have had the greatest difficulty in nomenclature. I feel there must be some more expressive and representative term, but I cannot light upon it, and therefore, in place of a better, I have used the word "mechanical." By using this term, I mean to imply that the limp arises from an error in alignment of the various portions of the osseous system which forms the skeleton of the lower limbs, and of the possible errors in alignment there are these common ones:

Actual shortening of the limb.

Adduction of the limb in relation to the plane of the pelvis.

Abduction of the limb in relation to a similar plane.

The mechanical limp may therefore have such widely divergent origins as a congenital dislocation of the hip, coxa vara, bow-legs, knock-knee, and former hip-joint disease, which, though cured, has resulted in abduction or adduction of the limb. In the mechanical limp, as I intend it to be expressed, there is no muscular weakness and no joint pain—it is purely the result of a mechanical error in the relationship to one another of the bones which form the lower extremities.

Stiff limps. This is the last general group I propose to recognize. It depends upon an ankylosis of one or other of the joints of the lower extremities—hip, knee, ankle, or tarsal joints.

Now that I have given this rough general classification let us reconsider the position.

By closely watching the child as it walks in front of you I believe it is possible to classify the limp into one or other group, and this by simple observation alone, without putting the hand upon the limb. Of course, there may be some overlapping in the classification. For example, I can quite well imagine a gait or limp which is "painful," and yet has some mechanical error which demands that it should be included in the "mechanical" class. Similarly, a mechanical limp may be combined with a stiff limp. I need not, however, enlarge upon these combined types.

Distinctive Features of Each Class.

Each variety of limp has one or more distinctive features by which we are able to recognize it.

The functional limp would appear at first as though it were a painful limp of an exaggerated degree, but it has two features which should at once arouse suspicion. The first is that every now and again the heel is quite firmly brought to the ground. Now, in a true "painful" limp this manoeuvre is most carefully avoided, except in the rare instances in which the origin of the pain lies in the fore part of the foot. The second distinctive feature of the functional limp is its variability in degree. At one moment it may be of the most exaggerated type, at another the limp is lost entirely, to be instantly reacquired. These two features, combined with the fact that on careful physical examination no lesion can be found, generally justify one in classifying a certain variety of gait or limp as "functional."

The painful limp. When a child has a diseased and painful focus in a limb it is most likely that pressure will increase the pain; therefore the distinctive point about the painful limp is the quite apparent unwillingness of the child to allow the full weight to be borne by the limb. It reduces to a minimum the amount of time during which the limb has to bear pressure, and some orthopaedists have descriptively termed it "the hurrying limp or gait." There are two other features generally present in painful limps. The one is that in order to avoid any jarring of the limb the heel is kept off the ground; exceptions to this rule are those cases in which the situation of the pain lies in front of the ankle-joint. The other characteristic feature lies in the fact that the various joints of the limb are held in a semi-flexed condition. This has as its explanation the attempt to diminish any jarring of the limb.

The flaccid limps are generally characteristic, and, according to the various groups of muscles which may be affected, different types of the flaccid limp appear. When the muscles round the ankle-joint are involved there is a distinctive high-stepping gait, with exaggerated lifting of the limb, in order to carry the paralysed foot clear of the ground. Around the knee-joint the extensor group of muscles are those most commonly affected, and in these cases the limp is very typical. The arm of the affected side is brought into use, and the knee is maintained in the extended position by keeping the hand firmly pressed against the front of the knee or thigh, the body being thrown forward to enable this manoeuvre to be carried out. If the muscles round the hip-joint are extensively paralysed it is likely that the child will be unable to walk without artificial support; if, however, the paralysis in this region is limited and walking is possible, there is a characteristic outward swing of the limb with the foot in an everted position.

In all the flaccid paralytic limps the distinctive feature is the want of control over certain movements, with often exaggerated manoeuvres of the healthy muscular groups.

The spastic limp. I need say very little of the characteristics of this type. The spastic condition of various groups of muscles is responsible for the spastic or "stotting" limp. The gait is forcible and jerky. It is well illustrated in spastic equinus, and it finds its most marked degree in the spastic diplegia or Little's disease. It is a limp which, once appreciated, is always easy of recognition.

The mechanical limp. I have defined the mechanical limp as being dependent upon an error in alignment of the bones which collectively form the skeleton of the lower limbs—I include therefore the pelvis. Of the possible errors in alignment there are three which I would mention as being responsible for characteristic mechanical limps—

Pure shortening of the limb.

Adduction of the limb in relation to the plane of the pelvis with apparent shortening, and

Abduction of the limb with apparent lengthening.

In the pure mechanical limp the limb is used as confidently as a normal limb—there is no muscular weakness, and no pain; the limp is therefore the result of the patient's effort to overcome the mechanical error which deformity or former disease or injury has induced.

If the error lies in pure shortening of the limb (as is

evidenced in congenital dislocation of the hip or in a fracture with shortening) there is a simple sinking of the pelvis towards one side. The sinking limp is best illustrated in a case of congenital dislocation of the hip, because in this condition not only is there shortening present, but, owing to the imperfect fixation of the hip, a further sinking is induced as weight is put on the limb.

If the limp arises from abduction of the limb in relation to the pelvis, the deformity may be wonderfully disguised. There are two points, however, which distinguish it—the patient walks with a broad base, keeping the feet well apart, while as each step is taken on the affected limb the body sinks towards that side. Frequently also the whole limb on the affected side is held stiffly, while it is swung outwards and forwards as progress is made. As a matter of fact, the pure mechanical limp of abduction is rarely seen. An abduction stiff limp is much more common. Here there is an ankylosis at the hip-joint, and, as the result of treatment of such a condition as a tuberculous hip, ankylosis has occurred in an abducted position.

Adduction of the limb produces one of the most characteristic and most distressing of all limps. To be able to walk efficiently the patient must go through a complicated manoeuvre, and as each step forward is taken a series of movements is really carried out. From the adducted position the limb is first abducted, and to do this the body is tilted toward the opposite side; the limb is now adducted to bring it as far as possible parallel to its fellow, the pelvis and the body sinking towards the affected side. As these lateral movements are in progress, forward movement is at the same time being carried out. It is easy to imagine the exertion and the deformity entailed in an adduction mechanical limp.

Stiff limps. The question of stiff limps I shall dismiss in a word. Whenever a joint of the lower limbs is ankylosed or stiff, a limp results. Stiff tarsal-joints and ankle-joints give a characteristic wooden appearance to the walk. This deformity is often wonderfully disguised. The knee, if ankylosed in a position of slight flexion, may give rise to wonderfully little disturbance in the walk, but a characteristic stiffness is always noticeable. The limp of an ankylosed hip is a combination of the stiff gait and the mechanical gait, according to the position in which the limb is ankylosed, and the shortening which may be present.

Examination of the Limb after Classification of the Limp.

My thesis up to this point has been that by observation of the method of walking it is possible to classify the majority of limps into certain groups, and, when this has been done, a great advance has been made towards the final diagnosis. But this is not sufficient—it is necessary now to localize the exact situation of the limp and, if possible, to come to an opinion regarding the pathological condition which is at fault. Now these points of knowledge can only be gained by a close study of the history and by a careful examination of the limb.

There is little I need say in regard to the history: while the parents' story is often misleading in so far as an injury, imaginary or real, always bulks largely in their eyes, one must remember that the natural maternal instinct of the mother qualifies her as an exceptionally shrewd observer. The history may be of great importance in recognizing the congenital nature of a limp. But, apart from the consideration of the history, the ultimate diagnosis will depend on the accurate examination of the limb.

The child, who should be stripped, having walked before me, I begin by noting the position of the limb as a whole—does it lie in a normal or in a deformed position? I survey the skin for any pathological appearance; I estimate by comparison of the two limbs the degrees of muscular development or wasting, and here I bear in mind a very simple, yet a very important, clinical fact—namely, that if the muscles of a segment of the limb are wasted (paralysis and dystrophies being excluded), there is some pathological change in the joints and bones over which these muscles play.

Any alteration in the outline of the limb is now looked for as being representative of an abscess or collection of fluid. My eyes are now directed to the joints of the limb;

the relative positions of the bony points are estimated, any joint fullness or error in position is noted.

Only when I have exhausted the observations of which my eyes are capable do I attempt to use my hands, and the use I make of them is largely to confirm what my eyes have already told me. I estimate by feel the character of the skin, I investigate any local swellings, I carefully palpate in turn each structure which collectively forms the limb. I therefore palpate the subcutaneous tissues, the muscles, the bones, and the joints. For example, my hands will tell me whether a swelling in relation to a joint is osseous, is due to a thickened synovia, or to the excess of fluid within the joint. I very carefully estimate the relative position of the bony points around a joint—this in view of a dislocation being present.

I then proceed to the investigation of the muscular functions of the limb. As far as possible, voluntary movement of the various groups of muscles is elicited. In the child this may be difficult, but by a little ingenuity and the exercise of patience the difficulty is overcome.

The joint movements are now investigated—first actively, then passively. Each movement of which the joint is capable is tested. Examination of the passive movements of the joint is, perhaps, one of the most important of all the stages of the survey; the results bulk so largely in the differential diagnosis. For example, I can imagine four pathological conditions in relation to the hip-joint, all of which are associated with a limp, and from examination of the passive movements of the hip-joint alone I can form at least a provisional distinction between them. Let me illustrate: If I am dealing with early tuberculous disease of the joint, flexion and rotation are limited by muscular rigidity. If Perthes's disease (osteochondritis deformans juvenilis) is the condition present, flexion is perfect, while rotation is limited; if there is a congenital dislocation of the joint, abduction and external rotation are limited; in coxa vara abduction only is affected.

I now proceed to measurement of the limb. First, the ileo-malleolar measurements are taken, and, if true shortening is shown to be present, I localize the situation by subdividing the original measurements into three—from the adductor tubercle to the median malleolus, from the tip of the great trochanter to the tubercle of the tibia, and, thirdly, by the estimation of Bryant's triangle or Nélaton's line. In one of these three areas I shall find the shortening. The second group of measurements, as estimated from umbilicus to median malleolus (the iliac spines being on the same plane), will give me an estimate of apparent shortening or apparent lengthening—in other words, of abduction or adduction of the limb.

There is another point in the examination of the limb to which I would allude. There are certain muscles which pass into the limb from a higher origin, and of these the psoas is the most important. It is therefore always wise to include an examination of the lower abdominal viscera and the lumbar spine in the routine investigation. Tuberculous disease of the lumbar spine with associated contraction of the psoas muscle produces a limp which is closely similar to that produced by hip-joint disease.

Up to this stage the examination requires no special apparatus or facilities, and by the time this stage is reached the diagnosis will probably have been made. The further examination ought to be rather confirmatory than otherwise; it will take the form of radiographic examination of the bones and joints of the limb. In these days, when x-ray facilities are so general, I am afraid we tend to resort to them too readily. If we do, then our clinical acumen will suffer. It is wiser to treat them as a diagnostic luxury, and to use them as confirmatory or otherwise of a clinical diagnosis.

I have no intention of attempting to describe the distinctive limp in individual diseases—I question very much if such a thing is feasible. My idea has rather been to look at the problem from a general aspect, and to attempt, if possible, to formulate a scheme upon which the problem may be worked out. If I may put the scheme into a few words (and after all it is so simple that perhaps the word "scheme" is too pretentious) the idea upon which I work is primarily to classify the limp, and this classification may be made entirely by observation of the gait; the type having been recognized, detailed examination

of the limb will generally succeed in localizing the site and the nature of the condition which has produced the limp.

The Treatment of Limps.

In this connexion, of course, it is only possible to speak in general terms. Each individual condition must be treated upon independent and special lines; but it is possible to express general ideas on the subject.

If it is decided that the limp is functional, the less the attention paid to it the better. Sympathy and local treatment will probably intensify and prolong it. The child responds readily to suggestion treatment. I have seen a girl with a pronounced functional limp walk normally after a short period of suggestion treatment. [A film representative of this case was shown.]

Painful limps call for early and careful treatment. The exact localization and pathological condition of the disorder must be recognized, and, this having been done, painful limps are treated by rest and immobilization of the part. We may take it, therefore, that for the limps recognized as being in the painful class, efficient rest of the limb is the first essential in treatment. Later, and depending on the pathological condition at fault, more special surgical treatment may be demanded, but with these indications I do not propose to deal.

Flaccid limps suggest wide possibilities of treatment; as the majority owe their origin to poliomyelitis, I would remind you that prevention is better than cure. During the acute stage of the illness, and subsequently, accurate splinting of the part in such a position as to relax the weakened muscles may well obviate the later development of a limp. When the limp has become established, mechanical treatment and operative treatment offer the most promising lines of treatment. In this connexion in recent years surgery has made enormous strides—tendon transplantation, silk fixation, and arthrodesis are often successful in restoring function to an otherwise useless limb.

Mechanical treatment by splints in children is often disappointing. The appliances should be of the simplest possible description, but the weight, the effort entailed in their use, and the education required are often detrimental to success. The present aim of surgery is to reduce to a minimum the use of mechanical appliances.

Spastic limps call especially for educational efforts. Occasionally surgery steps in beneficially with such simple procedures as tenotomy and tendon lengthening, but the intelligent use of corrective splints applied at night and careful education during the day produce good results.

Mechanical limps call for a special word of warning, and it is this: I believe that as a general rule it is a wrong principle primarily to condone a mechanical limp by some mechanical appliance. The common essential feature of most mechanical limps is shortening, and the aim should be to correct, if possible, the mechanical error which is producing the shortening, rather than to disguise it by such a procedure as heightening the boot sole. This should only be done as a final stage in treatment and after all other errors, such as adduction, etc., have been corrected. If raising the boot sole is the only remedy adopted, it may lead to a progressive increase in shortening.

Stiff limps generally call for little in the way of treatment. It is essential, however, that the part affected should be in the best possible position for subsequent ambulation. In the treatment, therefore, of any joint condition which may end in ankylosis, it is essential that care should be taken so to arrange matters that where ankylosis subsequently occurs, the joint concerned is in the best possible position—the ankle should be at right angles to the leg, the knee very slightly bent, and hip in moderate abduction, with slight outward rotation of the limb.

At one time we hoped that arthroplasty offered a possible method of restoring movement to ankylosed joints, but I am afraid that in the lower limb, at least, the results have been disappointing. We realize that there are worse things than a joint firmly ankylosed in a good position.

These are some of the points which have occurred to me in discussing the subject of limps. There is nothing new or original in the matter brought forward: I have merely attempted to put the subject before you in a consecutive light.

RESIDUAL VACCINES:

A NEW TECHNIQUE FOR THEIR PREPARATION, WITH A DESCRIPTION OF SOME PROPERTIES OF THE BACTERIAL RESIDUE.*

BY

C. E. JENKINS, M.R.C.S., L.R.C.P.,
PATHOLOGIST TO SALFORD ROYAL HOSPITAL.

With Clinical Notes by

C. C. HEYWOOD, M.B., A. CORSAR STURROCK, M.D.,
M.R.C.P., M.R.C.P.,

AND

G. J. LANGLEY, M.D., M.R.C.P.,
HONORARY PHYSICIANS TO SALFORD ROYAL HOSPITAL.

THE detoxication of vaccines has recently attracted considerable attention. Thomson's method¹ depends upon the fact that alkaline solutions dissolve organisms and their toxins whilst mineral acids precipitate the organisms but retain the toxins in solution. The chief merit of this method is that the final concentration ready for administration can be adjusted to any desired strength. Professor H. R. Dean² has shown that a suspension of virulent organisms can be detoxicated by the action of ensol or hydrogen peroxide in weak solution. The author has found it convenient to employ a method which embodies these two principles.

The term "detoxicated" is unfortunately somewhat misleading, and has even caused this type of vaccine to be looked upon with a certain amount of suspicion in some quarters. It has been thought that a preparation which is itself non-toxic cannot be expected to stimulate a protective reaction on the part of the tissues. If this were so, these vaccines might with reason be suspected. But it can be shown that they possess a toxicity of a definite type, and that this toxicity is contained in the bacterial residue which remains after the complete removal of the toxins and endotoxins. It therefore appears to the author to be more in accordance with a true description of them to call them vaccines of the bacterial residue, or more briefly, residual vaccines. The term "toxin" as used to-day has a restricted meaning, and in order to avoid confusion the toxic properties of the residue will be, as far as possible, referred to as the residual toxicity rather than the residual toxin.

Technique.

A sufficient quantity of growth is usually obtained from two or three Petri dishes. The growth is emulsified with about 100 c.c.m. of a 1 per cent. solution of phenol in sterilized tap water and the emulsion poured into a tall glass. The volume is noted and the number of organisms per cubic centimetre estimated. From a pipette sufficient 40 per cent. NaOH is added to form a 0.5 per cent. solution. The suspension is then set aside for an hour. During this time the suspension loses most of its opacity and becomes translucent, but rarely quite transparent. Strong HCl is next added drop by drop until the fluid is neutral to litmus, after which one drop of the acid is added for every 10 c.c.m. of fluid, which is now opaque once more. Lastly, hydrogen peroxide (10 vols.) is added in the proportion of 1 c.c.m. to every 50 c.c.m. of suspension.

The vessel is placed in a 55° C. oven and remains there for twenty-four hours, at the end of which time the organisms are found lying at the bottom of the glass as a dull white precipitate. The supernatant fluid containing the oxidized toxins is clear, and should be decanted, leaving the deposit behind. More 1 per cent. phenol is now added to make the fluid up to its original volume and acid added as before—namely, 1 drop to every 10 c.c.m. Peroxide is not added. Sedimentation is usually complete in three to six hours. The supernatant fluid is again poured away, the deposit neutralized by 40 per cent. NaOH, and the suspension made up to the required strength by the addition of normal saline, no further phenol being added, so that the final concentration contains phenol in a strength of 0.5 per cent. or less. Since tap water and not saline was present in the residue it might be thought that the final preparation is hypotonic, but the neutralization of the NaOH produces a solution of sodium chloride near enough to the strength of normal saline.

The strength per cubic centimetre and the dosage will depend upon the ratio of residual toxicity to the total toxins present in a culture grown upon a suitable medium. This ratio varies for different organisms, but a safe rule is to make the vaccine 100 times the strength of the corresponding ordinary vaccine, and to commence treatment with a small trial dose. No absolute rule can be laid down. The idiosyncrasy of the patient is just as evident with these vaccines, but as a rough guide it may be said that the initial dose of a residual vaccine should never exceed 1,500 millions.

* The expenses of the laboratory side of this work were assisted by a grant from the Department of Pathology, University of Manchester.

The last stage in the preparation is the sterilization, which is performed in the autoclave by heating for fifteen minutes at a temperature of 120° C. When the bottle is removed from the autoclave a fine precipitate is usually present, the supernatant fluid being almost clear. Both fluid and precipitate react normally to acids and alkalis; the deposit is easily passed into suspension again by slight shaking. Sedimentation is used instead of centrifugalization, because experience proved that to yield results a centrifuge must be of fairly large capacity and be capable of very high speed.

Sedimentation is slower, but the use of Dean's method reduces the washings to two and so tends to equalize matters. The oxidation method cannot be used alone because of its liability to produce a vaccine of inconveniently large bulk. The rate of sedimentation varies with different organisms, but the most refractory can be made to deposit quickly by boiling the alkaline solution for a minute or two, then adding the acid and setting aside in the 55° C. oven as usual. There is no need to repeat the boiling in subsequent washings.

How long the vaccine keeps without deterioration is uncertain, but it is much longer than is the case with thermolabile vaccines. The reaction of one particular vaccine was as strong as ever fifteen months after it was made; another, when nine months old, also showed no change in its toxicity.

Examination of the Precipitate.

The gonococcus was used to investigate solubility in NaOH. An emulsion containing approximately 1,000 millions per cubic centimetre was made with normal saline and a film examined. The cocci were of normal appearance. The suspension was converted into a 1 per cent. solution of NaOH. Much of the opacity immediately disappeared and the fluid became translucent, almost transparent. A film showed cocci present in large numbers with no amorphous deposit.

The suspension was next heated to 55° C. for forty-eight hours and resulted in a perfectly transparent fluid. A film showed cocci in greatly diminished numbers and a large amount of debris. It is difficult to give a precise estimate, but it seemed that about two-thirds of the cocci had disintegrated. It would therefore appear that the translucency is due to swelling of the organisms with an alteration in their light transmitting properties. True solution occurs later after comparatively prolonged action of the alkali. The observations were repeated with *B. coli* and gave similar results.

Reaction on Patients.

It is stated that the toxic symptoms seen with ordinary vaccines do not occur with residual vaccines. This is not in accordance with the author's experience. A local reaction is the most noteworthy feature. Shortly after inoculation a red area, slightly swollen, appears round the site of injection. It is commonly about three inches in diameter and painful to pressure, but not otherwise painful. The constitutional disturbance is variable, but in general is less than that seen with ordinary vaccines.

Clinical Results.

Over two hundred cases have been treated up to the present time, and according to reports received from the clinicians the results have been very satisfactory. There have been failures, but the results on the whole have been better than those one would have expected if the cases had been treated with the older type of vaccine. This is a facile statement, and one is aware that a detailed account is preferable. Circumstances arose by which more exact information was obtained.

A stock ordinary vaccine was required for a few men suffering from chronic bronchitis, and it was decided to treat a further number of patients with residual vaccine. These latter comprised that large group of cases of chronic bronchitis to be found attending the out-patient department of any large general hospital. They could not be said to offer much prospect of success with any form of treatment available to people in their station in life. Cases with severe cardiac or renal complications were excluded, otherwise no restriction was placed upon the age of the patient or upon the origin or duration of the disease; in fact for a period of six or eight weeks the out-patient department was drained for cases.

A large stock of a mixed suspension was collected, and from it was prepared an ordinary vaccine having the following composition:

M. catarrhalis (7)	70 millions per c.c.m.
Streptococcus (4)	15 " "
Pneumococcus (4)	25 " "
Friedländer's bacillus (5)	50 " "
B. influenzae (3)	10 " "
Hoffmann's bacillus (3)	30 " "
M. pharyngis sevens (1)	10 " "
Staphylococcus (6)	20 " "

The figures in brackets denote the number of sources from which the organisms were obtained. For the sake of brevity this vaccine will be referred to as the "O" vaccine.

The remainder of the stock was converted into a residual vaccine by the method previously described, except that it was divided into three parts, which were each sterilized in a different way. The first part was sterilized at 55° C. by means of 1 per cent. phenol acting at that temperature for twenty-four hours. This was called the "X" vaccine. The second portion was sterilized by heating at 95° C. for sixty minutes, and was called the "S" vaccine. The third part was sterilized in the autoclave, and called the "A" vaccine. Except for the method of sterilization these three vaccines were identical, and were made 100 times the strength of "O."

At this point it might be objected that any merit this type of vaccine may possess is due to a small amount of toxin which has escaped removal. In the case of "X" it would be 1/100th part of that originally present in "O" if, as was the case, the reaction caused by a given volume of either was approximately the same. The point can be discussed forthwith.

When a suspension is detoxicated by simple solution and sedimentation, the deposit is usually in volume 1/10th to 1/15th of the supernatant fluid, and the soluble toxins present in the water of the deposit will therefore be 1/10th to 1/15th of the total toxins originally present. But if the washing is repeated six times, the amount of toxin remaining will be considerably less than one millionth part of their former amount, if simple mechanical washing is the whole explanation.

Further, the reaction is not appreciably less if the organisms are washed twelve times instead of six, or if the author's combined method is used. Lastly, the suggestion does not explain the oxidation process in which the peroxide is evenly distributed throughout the suspension. The theory will not meet the facts. Most bacterial toxins are destroyed by a temperature of 80° to 90° C. The behaviour of the residue will be seen later.

A Series of Chronic Bronchitis Cases.

The results are presented in tabular form, and the intensity of the reactions and the amount of clinical improvement are shown by numerals which have the following significance:

Local Reactions.

- 0 = No reaction.
- 1 = Swelling, no pain; possibly tender on pressure.
- 2 = Swelling with erythema; painful, and stiff on movement.
- 3 = As in 2, but more pronounced. Erythema more than 3 in. in diameter. Shooting pain along arm in addition to pain at site of injection.

General Reaction.

- 0 = No reaction.
- 1 = Slight lassitude, but no definite malaise.
- 2 = Patient feels unwell, with headache and disinclination for food. Malaise disappears in twenty-four hours.
- 3 = Malaise more marked and lasting two or three days.

Degree of Improvement.

- 0 = No improvement.
- 1 = Slight, but clinically evident improvement.
- 2 = Moderate improvement with paroxysms of coughing much diminished.
- 3 = Marked improvement with complete, or almost complete, cessation of nocturnal asthmatic attacks.

Note.—The improvement was estimated by the physician to whom the case belonged and who was not informed as to what type of vaccine the patient had received, or the dosage.

"O" Vaccine.

Patient.	Age.	Duration of Dis- ease in Years.	First Dose.			Last Dose.			Number of Doses Given.	Degree of Improvement.
			Amount in Minims.	General Reaction.	Local Reaction.	Amount in Minims.	General Reaction.	Local Reaction.		
L. 4	40	3	2	1	1	14	2	0	6	0
S. 16	51	7	2	1	0	13	2	2	7	1
A. 4	38	5	2	0	0	17	2	2	3	3
A. 2	45	4	2	1	1	16	3	3	6	3
A. 3	40	4	2	1	1	16	2	2	1	1
L. 6	47	4	2	1	1	18	2	0	0	2
L. 11	50	5	2	0	0	17	2	1	1	1
L. 7	35	5	2	0	0	17	2	1	1	1
S. 18	38	3	2	3	2	10	3	0	6	3
Average improvement	1.66

"X" Vaccine.

Patient.	Age.	Duration of Dis- ease in Years.	First Dose.			Last Dose.			Number of Doses Given.	Degree of Improvement.
			Amount in Minims.	General Reaction.	Local Reaction.	Amount in Minims.	General Reaction.	Local Reaction.		
L. 1	35	4	3	1	3	15	2	3	7	3
L. 2	42	4	3	1	3	17	1	3	7	3
L. 3	46	5	3	1	3	17	1	3	7	3
S. 1	15	6	3	3	3	10	1	3	7	1
S. 2	32	6	3	3	3	15	2	3	7	3
S. 3	38	6	3	3	3	15	2	3	7	3
S. 4	47	6	3	3	3	7	2	3	7	3
S. 5	36	4	3	0	0	11	1	3	7	3
S. 6	49	5	3	1	1	7	0	3	7	3
S. 7	48	5	3	1	1	12	0	3	7	3
S. 10	35	3	3	2	1	5	0	3	7	3
S. 13	28	3	3	1	1	6	0	3	7	3
F. 1	28	3	3	2	2	8	1	3	7	3
L. 5	42	4	3	1	1	13	2	3	7	3
S. 18	43	4	3	1	1	9	2	3	7	3
H. 5	37	4	3	0	0	8	2	3	7	3
L. 27	38	4	3	1	1	7	2	3	7	3
H. 7	35	2	3	1	1	10	2	3	7	3
H. 1	42	4	3	1	1	12	0	3	7	3
Average improvement	2.21

"S" Vaccine.

Patient.	Age.	Duration of Dis- ease in Years.	First Dose.			Last Dose.			Number of Doses Given.	Degree of Improvement.
			Amount in Minims.	General Reaction.	Local Reaction.	Amount in Minims.	General Reaction.	Local Reaction.		
S. 8	39	5	2	0	1	13	1	2	7	3
L. 22	41	4	2	2	2	7	2	2	5	3
H. 6	38	4	2	0	2	9	1	2	4	3
A. 1	35	5	2	1	2	7	1	2	5	3
L. 9	39	7	2	1	2	10	1	2	5	3
L. 15	46	6	2	2	2	9	1	2	6	3
Average improvement	2.16

"A" Vaccine.

Patient.	Age.	Duration of Dis- ease in Years.	First Dose.			Last Dose.			Number of Doses Given.	Degree of Improvement.
			Amount in Minims.	General Reaction.	Local Reaction.	Amount in Minims.	General Reaction.	Local Reaction.		
S. 9	36	4	3	1	2	14	2	3	7	2
S. 11	41	4	3	0	3	10	1	3	5	2
S. 12	43	5	3	1	1	8	0	3	5	2
L. 10	47	7	3	0	1	11	0	3	6	3
L. 11	43	11	3	2	3	8	1	3	6	3
L. 12	33	4	3	1	1	14	1	3	6	3
L. 17	28	4	3	1	1	7	2	3	5	3
L. 18	39	5	3	0	0	8	2	3	6	3
L. 19	42	8	3	1	1	6	2	3	5	3
L. 20	44	5	3	2	3	8	2	3	6	3
L. 21	35	4	3	1	0	8	0	3	5	3
S. 14	43	6	3	3	3	7	0	3	6	2
A. 5	34	4	3	1	1	8	0	3	4	2
L. 23	45	6	3	2	3	6	3	3	5	1
L. 8	41	3	3	3	3	9	3	3	3	3
L. 16	35	3	3	1	1	1	1	3	5	3
S. 17	54	3	3	0	0	10	2	3	5	3
L. 24	37	3	3	1	2	8	2	3	4	3
L. 13	44	5	3	0	0	12	1	3	5	3
L. 25	33	4	3	0	0	9	2	3	5	3
H. 8	47	3	3	0	0	10	1	3	5	3
H. 9	36	3	3	0	1	10	3	3	5	3
H. 11	34	4	3	0	2	7	1	3	5	3
H. 12	35	5	3	0	2	8	2	3	5	3
H. 3	34	3	3	0	1	8	2	3	5	3
H. 4	56	3	3	0	3	8	2	3	5	3
H. 10	38	4	3	0	1	10	2	3	6	3
Average improvement	2.30

It is recognized that this method of presenting the facts is open to criticism, but it is the only way in which the records of such a large number of cases can be within reasonable limits. The use of the method was determined by the available supply of syringes.

Analysis of Results.

The "O" results are not put forward here to demonstrate that residual vaccines are superior to thermolabile vaccines—as in fact they are—but to afford a comparison of the general and local reactions, and hence of the toxicity.

The average of the general reactions in the "O" group is slightly greater than that in the "X," "S" and "A" groups, but the local reactions in these latter exceed those in the former group, and are possibly to be explained by the imperfect solution of the bacterial debris with consequent slow absorption, this in turn necessitating a strong local reaction to break it up and pass it into solution.

The reactions of the "A" group prove that a temperature of 120° C. is not detrimental to a residual vaccine, so the "S" results are superfluous, and should be read as part of the "A" group.

A very noticeable feature of the constitutional disturbance caused by the residual vaccines was the frequency with which it was of an intestinal nature. Whenever a "G.R. 3" was produced a disinclination for food was invariable, and in about half the cases was accompanied by some vomiting and diarrhoea. The latter symptoms disappeared in eight to twelve hours after their onset. Diarrhoea alone and of mild degree was common also with milder reactions, but only after the first or second dose. The gastro-intestinal disturbance was never seen in the "O" group, and it would therefore appear that bacterial residues differ from thermolabile toxins in their physiological action as well as in their chemical properties. This phenomenon has been observed with other vaccines of the same type, but only when either the pneumococcus or streptococcus was contained in the vaccine.

Another point which is brought out in the tables is the size of the last dose given. It will be noticed that the "O" group reached an appreciably higher number of minims than any other group, and during the course of treatment one could not help observing that the "O" group tolerated much greater percentage increases of dosage. When weighing this fact it should be recollected that all four groups started with the same number of minims to which they reacted to approximately the same extent.

It is a common method when using thermolabile vaccines to increase each dose by 30 to 40 per cent. above the preceding dose, and one therefore works by a geometrical progression; the method is not applicable to residual vaccines, or is so only within narrow limits. The patient cannot tolerate such increases.

The dose should be increased by some fixed amount—which was two minims in this particular series—and even then many patients required the same dose repeated once in order to establish a comfortable tolerance. It was abundantly clear that the defensive mechanism of the tissues found a greater difficulty in dealing with the toxicity of the residue.

The improvement after each dose of all the residual vaccines was greatest after the first three or four. The later doses produced a much slower improvement until it ceased altogether after the seventh dose or thereabouts. It is hoped to investigate this further at a future date. The extent of the benefit, as well as the reactions, in the "X," "S," and "A" groups is equal, and is a further proof that heat is not detrimental to the residue. The simplicity of sterilization in the autoclave compared to the usual gentle heating and subsequent testing by cultural methods is obvious.

Nature of the Toxic Substance in the Residue.

It will be apparent that the residue contains a toxic substance. Vaughan³ has shown that certain toxic bodies, apparently allied to proteins, can be obtained from bacteria, and that these bodies withstand a much higher temperature than do toxins and endotoxins. It has further been shown that some degree of immunity can be created against them, and that the local reaction when they are injected is intense. The precise origin of the toxicity may be somewhat vague, but it is evident that the residue possesses some properties which show fundamental differences from those of thermolabile toxins, and which are striking enough to justify one in separating the residual toxicity from the endotoxins.

The two cardinal features which distinguish the class are:

1. They are not rendered inert by weak solutions of oxidizing agents.
2. Their toxicity is neither destroyed nor impaired by a temperature of 120° C.

In this investigation the extent of constitutional disturbance has been taken as the standard by which to compare the toxicity of the residue with that of the thermolabile toxins. It is a reasonable physiological test, but it should be remembered that it is only a measure of the relative toxicity; it affords no indication of the relative weights of the two classes present in a culture or of the relative toxicity of the types if equal weights of each are taken.

The dose of an ordinary vaccine depends upon the amount of toxin present. The strength is stated in organisms per cubic centimetre because that is the only method of measurement available, unreliable as it is. The number of organisms is no real guide to the dose, for different strains of the same organism vary enormously in toxicity, and the amount of toxin produced by any given strain varies with the medium upon which it is grown. It is not possible to standardize the thermolabile toxin, for that substance is very unstable and becomes inert from many causes, all of a comparatively trivial nature. If the toxin is standardized when the vaccine is made, the result may be worthless in less than a month. Furthermore, the production of toxin is not an essential metabolic process, so the destruction of it does not necessarily incommode the organism at all. Antitoxins will neutralize toxins and nothing else.

It is true that a thermolabile vaccine contains bacterial protein, but only because of its accidental and unavoidable presence as part of the organism which accompanies the toxin. Its amount is small and the actual quantity quite indefinite. In effect the patient is immunized against the toxins. The destruction of the organism is left to the tissues to manage as best they can.

The rationale underlying residual vaccines rests upon a more solid basis. In these the toxic substance against which immunity is produced is the tissue protein of the organism itself, the preservation of which is essential to the life of the parasite, and the vaccine is therefore designed to strike at the primary cause of the disease; if the causal organism is destroyed its toxin can be ignored, for it will disappear whether the patient destroys it or does not.

The counting of the organisms in a residual vaccine yields information which remains accurate, the relationship of the toxic residue to the organisms being a fixed ratio, and since the residue is very stable, its toxicity does not change with age.

Finally, the therapeutic results obtained with these vaccines are more uniform. The degree of improvement is quite as great in the most promising cases, and a larger proportion of the cases benefit by the treatment. Almost all the cases in this series were drawing either a pension or sick pay, and this fact undoubtedly influenced their own estimation of the benefit received. Physical signs may be negligible or altogether absent, but it is impossible to disprove that a man still has a cough, and for this reason no case has been entered as cured. It is fairly certain that the estimates of the improvement are not unduly sanguine. This aspect of the work was realized from the start, but previous experience with the vaccine had inspired a belief that it would justify itself even under a handicap that amounted to an unfair test.

Since it has been shown that the effect of heat upon the residue is nil, the "X," "S," and "A" sections can be amalgamated into one large group in which the clinical benefit derived from residual vaccines can be demonstrated in a short table:

	Degree of Improvement.			
	Nil.	Slight.	Moderate.	Considerable.
Total number of cases treated, 52	3	9	13	27
Percentage	6	17	25	52

CLINICAL NOTES.

Chronic bronchitis as a distinct entity is especially prevalent in Manchester and Salford. Many cases date from an attack of acute bronchitis contracted on active service in France. Attacks of a spasmodic or asthmatic type are very frequent. The expectoration varies greatly in different cases, but is usually abundant and mucopurulent.

The physical signs include marked diminution of expansion and respiratory capacity, hyper-resonant percussion note, and widespread mixed râles and rhonchi. There is marked deterioration in health and capacity for employment, and as a rule there is evidence of cardiac muscle weakness.

In the presence of such changes in the physical state of the chest, and probably of permanent changes in the anatomical structure of the lungs, the influence of vaccine treatment must necessarily be limited, but several salient facts emerge from observation of a series of cases treated in this manner:

1. In most cases there is distinct improvement in the patient's general condition, in colour, vigour, and capacity for activity.
2. The sputum, which may at first increase in amount, in practically every case diminishes in quantity and loses its mucopurulent character, becoming white and less profuse.
3. The cough becomes less persistent and the attacks or paroxysms much fewer and less severe, particularly those occurring in the night and early morning.
4. A striking feature has been relief from asthmatic attacks; from the clinical point of view this is the most conspicuous effect produced by the treatment.

The clinical observers have not known the type of vaccine employed in any given case, and the results must speak for themselves.

Summary.

1. It is not possible, short of gross destruction, to detoxicate completely a suspension of pathogenic bacteria.
2. The residual toxic substance is not affected by a temperature of 120° C., it is not destroyed by weak solutions of oxidizing agents, but it is precipitated by mineral acids.
3. It is possible to remove from a suspension of organisms all the thermolabile toxins and endotoxins. Thomson's method, Dean's method, or that of the author are equally efficient.
4. It is probable that the residual toxic body is an integral part of the bacterial protoplasm.
5. Residual vaccines can be sterilized in the autoclave, so sterilization is simple and certain.
6. Residual vaccines are highly efficient therapeutic agents.
7. They retain their maximum efficiency indefinitely.
8. Most cases of uncomplicated chronic bronchitis respond to treatment by residual vaccines.

The author cannot conclude without acknowledging his indebtedness to Professor Dean for much valuable advice and constructive criticism, and to the physicians who contributed the clinical notes for their kindness in undertaking the large amount of clinical work which this investigation required.

REFERENCES.

¹D. Thomson, *Lancet*, 1919. ²H. R. Dean, *BRITISH MEDICAL JOURNAL*, April 29th, 1916. ³Vaughan, *Protein Split Products*, Philadelphia, 1913.

ENCEPHALITIS LETHARGICA.

BY

G. S. HAYNES, M.D., M.R.C.P.,

ASSISTANT PHYSICIAN, ADDENBROOKE'S HOSPITAL, CAMBRIDGE.

[AFTER a brief reference to the history of the disease, and the use of the term "encephalitis lethargica," Dr. Haynes quoted a classification of the symptoms given by Dr. F. M. R. Walshe in *Brain*, November, 1920. The primary division was into general symptoms and nervous symptoms. General symptoms were such signs of toxic infection as fever, eruptions, malaise, pain, headache, and gastrointestinal disturbance. The nervous symptoms were general or focal, and in each case were classified as

positive or negative, the terms being employed in the sense in which Hughlings Jackson originally used them.]

Positive symptoms are expressions of exalted function, either from irritation or loss of higher control, and negative symptoms express depression or loss of function. The general positive symptoms in lethargic encephalitis are delirium, restlessness, hallucinations, and so on; the general negative symptoms lethargy and coma. The focal positive symptoms are convulsions, involuntary movements and muscular contractions, ataxy, rigidity, and pain; the focal negative symptoms are paralyses.

Recognition of these two classes of symptoms—positive and negative—is very helpful, enabling us to understand that a lesion of a single area might give rise to convulsions as well as to paralysis, and that whether a clonic twitching of a muscle or weakness occurred depended not on the site, but upon the nature of the lesion.

The disease occurs at all ages, and affects both sexes equally. Three stages can be distinguished—the prodromal stage, the acute stage, and the stage of regression. The incubation period has not yet been determined. The chief prodromal symptoms, which last usually from one to seven days, but may be prolonged for three weeks, are headache, giddiness, lethargy, blurred or misty vision, and diplopia; vomiting is not common; muscular weakness frequently occurs.

The acute stage is characterized by fever (101° to 102° F.), lasting from two to five days or longer, the pulse and respiration being as a rule unaffected. The patient lies in bed semi-conscious and immobile, or with much muscular asthenia; the face is expressionless and mask-like; the limbs in many cases are rigid, and in some they remain in any position in which they are placed, as in the condition known as *flexibilitas cerea*. Usually patients can be roused from their stupor to take food or to answer questions; this they do intelligently, but in a voice often nasal and monotonous, the sentences being uttered very slowly. There may be emotional irritability, and nocturnal delirium frequently occurs. In this stage muscular twitchings and tremors may occur. There is no characteristic skin eruption, though petechiae, papules, or erythema have been observed; one case was notified as scarlet fever and another as measles. *Tache cérébrale* is readily elicited in most cases. Other symptoms are dysphagia, nausea, and constipation; the tongue is dry and coated. Retention or incontinence of urine is of frequent occurrence; the urine is concentrated, loaded with urates, and transient albuminuria is found during the febrile stage.

Paralysis of the cranial nerves is a characteristic feature the third and seventh being most commonly affected. The fundus oculi is normal. Ptosis is the usual form of third-nerve paralysis; it may be unilateral or bilateral, and slight or complete. The ciliary muscle is often involved early and paralysed longer than other ocular muscles; the pupils may be unequal; divergent or convergent squint is seen; diplopia is common. Whereas ptosis and strabismus are only transient, involvement of the movements of the eyeball may last several weeks, as may disturbance of accommodation. Facial paralysis has often been observed; it is, as a rule, bilateral, but more marked on one side than the other; the tongue and pharynx are sometimes affected and deafness has been noted.

Netter's statistics place the frequency of lethargy and ocular palsies as high as 75 per cent. of all cases, but, though with fever this is the characteristic syndrome, a large number of cases do not conform to this type; some begin with excitement and muscular twitchings or spasms, or with severe pains in the limbs; others have quiet delirium with delusions; others, again, go about with persistent headache, apathy, and lack of facial expression. In fact, as Farquhar Buzzard has pointed out, an inflammation of the encephalon can produce as many symptoms as there are functions of the brain.

Of the lethargy, which is an interesting feature of the disease, three explanations have been suggested: (1) That it is due to internal hydrocephalus, the result of occlusion or partial occlusion of the aqueduct of Sylvius by inflammatory processes in the region of the corpora quadrigemina. It is noted that sluggishness or total abolition of the pupillary reflexes frequently occurs with the lethargy, and that this combination is characteristic of tumours of the posterior end of the third ventricle. (2) That it is due to interference with the afferent paths of stimuli from the

* Abstracted from a paper read before the Cambridge Medical Society.

environment, whereby stupor results. It is argued that an inflammatory lesion in the crura cerebri and optic thalami might, in addition to blocking afferent stimuli, involve the nucleus of the third nerve and give rise to the frequently observed ocular phenomena. Optic neuritis is generally absent, indicating that the lethargy is not part of a general cerebral condition, such as would be caused by hypertension, as in tumour or abscess. (3) That it is due to pressure on and inflammation of the pituitary gland. Sluggishness, with a tendency to somnolence, is a sign of hypopituitarism.

The differential diagnosis of the characteristic syndrome, with "negative" nervous signs, is to be made from the following conditions: Cerebro-spinal meningitis, in which there is commonly retraction of the head and a turbid spinal fluid containing the meningococcus; tuberculous meningitis, a somnolent form of which may occur in infancy, characterized by a dissociation of pulse and temperature and irregularity of the pulse, choked disc and choroïd tubercles, with lymphocytes, albumin, and frequently tubercle bacilli in the spinal fluid; influenza encephalitis, usually accompanied by bronchial or pulmonary signs. Cerebral syphilis is generally unaccompanied by fever; optic neuritis is frequently present, and the complement deviation test is in most cases positive. Sleeping sickness is distinguished by the presence of the trypanosome in the blood, cerebro-spinal fluid, and enlarged glands. Cerebral forms of poliomyelitis are rare; they commonly occur in the summer months; the paralyses are more generalized and are maximal when declared, whereas in lethargic encephalitis the paralyses are often slight at first but progressive. Cerebral softening, following embolism or thrombosis, or cerebral haemorrhage may simulate encephalitis, in which large areas of softening and gross haemorrhages have been found. Naked-eye *post-mortem* changes are not sufficient to distinguish between ordinary cerebral haemorrhage and a haemorrhagic encephalitis.

The diagnosis of cases presenting "positive" nervous signs, the excito-motor syndrome, is more difficult, especially when a history of an acute attack is lacking. Such cases are those showing involuntary movements and muscular contractions; they have been classified by Marie and Levy, who describe forms resembling chorea and paralysis agitans, and forms with rhythmical and myoclonic movements of the face, trunk, and limb muscles.

These excito-motor signs may not develop until weeks or even months after apparently complete recovery from the acute illness or after an unrecognized mild attack.

If no history of an initial acute illness be obtained the following minor symptoms may confirm the occurrence of a mild attack: onset of an illness with occipital headache and painful rigidity of the neck, accompanied by slight fever and nocturnal delirium; disturbances referable to the muscles of mastication, such as difficulty in opening the mouth fully, tremor of the jaw, chattering of the teeth, neuralgic pains in the distribution of the fifth nerve; attacks of facial spasm; excessive salivation; slowness and difficulty in articulation; a sense of constriction of the throat with difficulty in breathing or swallowing; frequent attacks of yawning or of hiccup; slight painful swelling of joints, and finally, neuralgic pains of root distribution and painful muscular cramps. One or more of these symptoms associated with slight signs of general infection indicate the occurrence of the initial infection.

The diagnosis of lethargic encephalitis can never depend upon the presence or absence of any symptom or group of symptoms. It must be determined by a consideration of the onset and course of the disease, and by the elimination of other pathological conditions which may produce similar symptoms and physical signs.

The course of the disease is very variable. Some cases are rapidly fatal, death being apparently due to paralysis of the respiratory nervous centres. The stupor may clear away in a few days or persist for several weeks, even as many as eight, and recovery may then ensue; pneumonia, wasting and bedsores have been noted as fatal complications.

The Cerebro-spinal Fluid.

The cerebro-spinal fluid is normal in appearance; in some cases, but not in all, it is under pressure; during the first few days lymphocytosis may occur, but this is not one of

the fundamental characters of the disease, as it is of tuberculous or syphilitic meningitis, and is only of short duration; an excess of glucose is frequent but not constant, and is attributable to a certain degree of hyperglycaemia due to a lesion of the floor of the fourth ventricle.

The Blood.

The blood count is normal. Some Italian bacteriologists have isolated from broth cultures of the blood a small Gram-positive diplococcus, which was agglutinated in a dilution of 1 in 100 by the serum of the patient from whom it was isolated, and by that of other patients and of convalescents from the disease. It was not agglutinated by normal blood or by the blood of typhoid patients. Guinea-pigs inoculated with blood containing the diplococcus died on the fifth or seventh day after presenting subnormal temperature, paresis of the limbs, intense somnolence and often muscular jerking of the limbs. The brain showed punctiform haemorrhages, especially in the grey substance.

In the Government report referred to previously, James McIntosh states that, as a rule, no macroscopic changes sufficient to account for death are found *post mortem*. A common appearance is dilatation of the vessels, which in many instances is likely to be mistaken for haemorrhage. Histologically the changes consist of cellular infiltration of the perivascular lymphatic sheaths and of certain areas of the grey matter. The lesions are most extensive in the basal nuclei of the brain, in the upper part of the pons, particularly in the grey matter of the floor of the fourth ventricle, much less prominent in the medulla; in the cord lesions are very slight or absent.

At the annual meeting of the British Medical Association held in Cambridge last year Dr. Greenfield showed a series of lantern slides illustrating the morbid anatomy of this disease. The changes found in most early fatal cases were very diffuse, and could usually be traced from the medulla to the cortex. The most constant appearances were capillary dilatation and infiltration of the brain substance with small cells of the lymphocyte type, which were often grouped round the nerve cells as though attacking them. A comparatively common feature of the disease was infarction of the brain due to thrombosis of smaller or larger arteries.

In cases of longer standing calcareous and thrombotic changes in the vessel walls were sometimes found.

Other observers draw attention to the occurrence of gross haemorrhages chiefly in the mesencephalon.

Loewe and Straass find that the Berkefeld filtrates of brain material, nasopharyngeal swabs, and nasal washings from cases of epidemic encephalitis produce the typical lesions of the disease in rabbits and monkeys. Spinal fluid and blood are also capable of producing the disease in this way; many of the infected animals die with the typical clinical picture of lethargic encephalitis. These observers have succeeded in cultivating a minute filtrable organism, seen as clumps of minute globular bodies with Brownian movement, young cultures of which are Gram-positive. It is obtained from the brain, nasopharyngeal mucosa, cerebro-spinal fluid, and blood of cases of the disease in man and from inoculated animals dead of the disease. The organisms thus recovered from rabbits are virulent for other rabbits.

The prognosis is not good; death occurs in from 40 to 50 per cent. of cases notified, but as probably many mild or abortive cases are not recognized and not notified the true mortality is almost certainly less.

In severe cases which recover from the acute stage, sequelae, such as impairment of the higher faculties, loss of memory, defects of speech, mental lethargy, and a general loss of intellectual tone, are common. Other sequelae are the persistence of cranial nerve palsies, paresis, and even paralysis of a limb or of limbs, athetosis, myoclonus—that is, sudden shock-like spasms of limbs, sometimes also of diaphragm and larynx. In one of my cases this myoclonus is well marked fifteen months after the onset of the disease. Symptomatic paralysis agitans may be observed. Recovery from the disease is, as a rule, gradual and tedious, chiefly on account of the great prostration and muscular weakness that are so common.

Treatment.

No specific treatment is known. Hexamine, as being the most active disinfectant of the cerebro-spinal fluid, has

been largely used; it has been given by the mouth, by the rectum, and intravenously.

Lumbar puncture, repeated at intervals, has been used with some success. The intravenous injection of salvarsan has been tried in some cases and good results reported.

The French have treated many cases by fixation abscess; 1 or 2 c.c.m. of oil of turpentine is injected subcutaneously into the middle part of the outer surface of the thigh. If no reaction occurs at the end of a few days, the injection is repeated. The resulting abscess is incised on the fifth or sixth day, or it may be aspirated. The pus is sterile. That this method is efficacious in the collection of toxic substances into one part of the body is shown by the following experiments. Toxic doses of arsenic in the form of sodium cacodylate were given to animals, and at the same time an experimental abscess was produced. The animals recovered from the arsenical poisoning, and a large proportion of the arsenic administered was recovered in the pus. A disadvantage of this form of treatment is that sometimes severe pain is caused. It has been used in cases of cerebro-spinal meningitis and of influenza and pneumonia. Other remedies which have been tried in lethargic encephalitis are strychnine, horse serum, and the serum of convalescents.

During convalescence the patient should be kept at rest and free from worry; sedatives and hypnotics, such as ammonium bromide and chloralamide, being prescribed, if required, in order to limit the liability of permanent cerebral lesions occurring.

Of the thirteen cases I have seen, ten were under treatment in Addenbrooke's Hospital. Most of them were of severe type, and seven died.

The following is an example of a case of average severity:

A woman, aged 24, had been in poor health for some months; in October, 1920, her tonsils were removed, and she subsequently resumed her work. About the middle of December she became sleepy and apathetic, and was troubled by vomiting in the morning. The vision became hazy, and she had difficulty in focussing. On December 21st, she complained of frontal headache and sleepiness; she was lethargic, lying with her eyes closed, but easily roused, answering questions briskly and intelligently, and then relapsing into slumber. The temperature was 103°, the tongue thickly coated, and the reflexes very sluggish; otherwise no abnormal physical signs were observed. She was admitted to Addenbrooke's Hospital on December 22nd, and for about a fortnight remained in a drowsy condition with constant headache, and mental condition slightly confused. She had partial double ptosis, misty vision, occasional diplopia, stiffness of the masseters with inability fully to open the mouth, and paresis of the facial muscles. A recurrence of vomiting and increase of headache came on three weeks after admission, but this passed off in a few days, and the condition slowly improved, so that she was discharged after five weeks in hospital. During this time she lost nearly two stone in weight. She is now making progress, but very slowly. There is still much muscular weakness, and considerable mental depression. She is gaining 1 or 2 lb. a week in weight.

The following is an example of a very severe type of case:

A woman, aged 21, consulted a doctor on December 8th, 1920, for misty and double vision. She was sent home to bed, but grew weaker and became comatose. When first seen on December 11th she was very drowsy but could be roused to answer questions, which she did in a sleepy voice, slowly, immediately relapsing into stupor. There was some fever, a crop of red papules on the chest only, double ptosis and right external strabismus, twitching of the right ala nasi, coarse tremors, and rigidity of limbs with flexibilitas cerea.

On admission to Addenbrooke's Hospital on December 11th the coma increased, and the temperature rose; it reached 105.6° in the early morning of December 16th, when the patient died.

The result of the examination of the cerebro-spinal fluid was negative; there were no pathogenic signs; there was a little excess of sugar.

In the following case myoclonus was a prominent symptom.

A woman, aged 30, attended as an out-patient on June 9th, 1920, complaining of aching in the left arm and leg, with "jumping sensations." Her illness had commenced at Christmas, 1919, with sleepiness and loss of speech lasting a fortnight. In February there was aching in the back of the neck, and later in the left side, arm, and neck. Involuntary movements of the left arm and leg now commenced and have continued ever since.

On examination the general condition was found to be good. There was tenderness about the left deltoid, the muscles of the left shoulder girdle generally were slightly wasted, and the circumference of the left calf was 1½ in. less than the right.

There was no paralysis, no ocular palsies, no sensory changes, and the reflexes were present. There were jerky involuntary movements of the affected arm and leg, occurring about every two minutes. The condition suggested hemichorea.

After treatment with arsenic and bromides with but little improvement, she was admitted. Dr. Prideaux reported as follows: "I do not think there can be any doubt that this is a genuine case of myoclonus associated with encephalitis lethargica. She is certainly not a functional case, though, as in other cases of myoclonus, the spasms are increased during emotional excitement and in fatigue. The prognosis is fairly good—that is, eventually it should clear up; cases hitherto reported have cleared up in from six months to three years."

When seen on April 2nd, 1921, fifteen months after the onset of the disease, she complained of great weakness, unsteadiness of the legs, constant twitchings of the left arm and leg, and sleeplessness. Her general condition was very poor; she was pale, weak, and thin; there was some instability on walking, and especially on turning; she was apathetic and dejected, and her face expressionless; there were regular rhythmic movements of the left arm caused by clonic spasms of the muscles of the left subscapularis, and also similar movements in the left leg synchronous with the arm, caused by spasm of the hamstrings. These movements ceased at times, and were not present during sleep.

REFERENCES.

Reports to the Local Government Board, No. 121. Walsh, J. M. R.: *Brain*, November, 1920. Crookshank, F. G.: *BRITISH MEDICAL JOURNAL*, December 11th, 1920. *Proc. Roy. Soc. Med.*, vol. xiii, 6; vol. xiv, 2. Marie, P., et Levy, Mlle. Gabrielle: *Rev. Neurol.*, Juin, 1920. Loewe and Strauss: *Journ. Infec. Dis.*, 1920, xxvii, 250. *Medical Science*, vols. i and ii.

OCULAR SYMPTOMS IN THE SLIGHTER CASES OF ENCEPHALITIS LETHARGICA.

BY

RANSOM PICKARD, C.B., C.M.G., F.R.C.S.,

EXETER.

THERE is a special fascination in the study of borderland cases of any disease. Moreover, to obtain a complete picture of any subject it is necessary to study its fringes. The following cases are cited as bearing upon the ocular symptoms in slight cases of lethargic encephalitis; doubtless there are other groups in which symptoms other than ocular predominate, but they would not come to an oculist.

CASE I.—*Diplopia; Paresis of Accommodation; Retrobulbar Neuritis; Drowsiness.*

C. H., aged 32, was first seen on February 11th, 1921. His illness had started three weeks earlier with diplopia for two days, and drowsiness for a week. At the beginning there was pain in the frontal region and at the root of the nose, and "weakness of the eyes," "darkness, as if a blind were drawn down." On February 11th, vision with correction was: R. 6/6, L. 6/12; loss of accommodation was: R. +75, L. +1. There was no diplopia present. The discs were white and filled in, the edges very well defined, the branches emerging after division suddenly out of the white disc; the main vessels were not visible. This condition was more marked in the right eye.

Fields (white object) 5/300:

	Up.	In.	Down.	Out.
Right eye	25°	20°	20°	35°
Left eye	20°	25°	22°	50°

The blind spots were not charted.

The condition on May 2nd (communicated) was:—With correction: R., 5/5; L., 5/10. Near vision with same correction: R., J. 1; L., J. 1, imperfectly; there was no diplopia, the fundi was unchanged, the general condition was much better, and work was about to be started.

CASE II.—*Diplopia; Paresis of Accommodation; Sleepiness; Weakness of Limbs; Retrobulbar Neuritis.*

Mrs. B., aged 53. Her history was as follows: On February 27th, 1921, diplopia and sleepiness began. On March 2nd, on waking, she found that she could not walk without help because of weakness of the legs. On March 11th the condition was that she had near glasses +3.5; distance glasses +2. Her vision was R. +2 = 6/12; L. +2 = 6/9 partly. The loss of accommodation was +2.5 in each (not excessive for her age, but apparently +1 more than before the attack). The irides and fundi were normal. In regard to the fields, the right eye was contracted to from 20 to 30 deg., and the blind spot enlarged (object 5/300 white). The left eye was contracted to from 15 to 20 deg.—that is, inside the blind spot (object 5/300 white). Diplopia was crossed, and was greatest in the right half of the field; that is to say, there was paresis of the left internal rectus. The limbs were weak, but the left arm and leg were weaker than the right arm and leg. The knee-jerks were equal and exaggerated. Her memory was bad. The subsequent history (communicated) was as follows: On March 29th diplopia disappeared; on April 12th vision became normal; on April 18th she was well in every respect, except for her memory, which remained very bad.

CASE III.—*Diplopia: Paresis of Accommodation: Congestion of Optic Disc: Lethargy: Delirium.*

Mr. K., aged 44 years. The history obtained was that, on February 21st, 1921, there was difficulty in reading and writing with diplopia. On February 24th he came to be tested for glasses because he found that he could read with his wife's glasses. He said he had been sleepy for the last few days. His condition was as follows: Vision: R. +1 = 6.5 + 1.5 = J. 1 at 13 inches; L. +1 = 6.5 partly + 1.5 = J. 1 at 13 inches. The irides were normal. The right disc of the fundi was slightly congested, the edge was sharp and there was a local swelling between the edge of the cup and the inner margin of the disc. The left disc was normal. There was diplopia, the images were uncrossed, on the same level, and separated by three degrees equal in all parts. There was paresis of divergence or spasm of convergence, but not paresis of a muscle. The subsequent history was communicated. The lethargy increased, with some delirium at night; there were involuntary tremors and general weakness, also slight paresis of one facial nerve. The temperature was 101° to 102° for five days. There was no albumin in the urine. On April 30th he had returned to business, but was still unable to read.

CASE IV.—*Diplopia: Paresis of Accommodation: Lethargy.*

Mrs. C., aged 36 years. On December 11th, 1920, she saw the tops of things double. This condition persisted for four days, but afterwards her sight was "unreliable"; she was giddy and also very shaky. She had some pain at the back of her left leg. On December 15th she was seen by her medical attendant, who found that the right pupil was larger than the left and that there was slight diplopia. On December 23rd the condition was as follows: Vision correction, R. 6.5 (6); L. 6.5 (3); the loss of accommodation R. +1 D.; L. +1.25 D. The irides: right pupil 3.5 mm., with very slight reaction to light and convergence; the left pupil was 2.5 mm., the reactions were normal. The diplopia was vertical, and confined to the lower right quadrant, the greatest in the lowest portion. There was paresis of the right inferior rectus. The knee-jerks were equal and exaggerated. She was pale and looked ill, but was not sleepy. Later on she became somewhat lethargic. On April 25th, 1921, she was well in all respects except that her eyes got tired after much reading, and the reactions of the right iris were sluggish.

In addition to these four cases the following may be mentioned:

CASE V.

A man, aged 52 years, seen during the later stages of recovery. There was a history of diplopia and difficulty in seeing in the earlier part of the illness. When seen there was no diplopia, and loss of accommodation was +2.5, rather full for his age. The discs were redder than normal.

A household of four adults—husband, wife, child of 5 years, and lodger—was mentioned in a letter by the medical attendant of Case III. They were all sleepy, and each adult in turn accused the others of being cross-eyed. The lodger recovered without giving up his work as a bank clerk, although he sometimes fell asleep on his lodger, and had diplopia for all distances beyond 3 ft. from his eyes. This account of his diplopia suggests paresis of an external rectus. House groups have been described, but one consisting only of light cases must be rare.

Taking a general view, it will be seen that the cases are in the main miniatures, reproductions of severe cases on a reduced scale, rather than differing from these by the omission of certain symptoms.

Collecting the symptoms together from the various cases, the following points arise:

1. *Paresis of the ciliary muscle* is usually present, but is slight in degree and slightly different in the two eyes; from 1 D. to 1.5 D. being a usual amount. As the amount of manifest hypermetropia or presbyopia varies considerably in different patients under fairly similar conditions, it is not easy to state definitely the amount of paresis present; but in these cases the histories were fairly conclusive that there was paresis and that this was slight.

From the history it seems probable that the loss of accommodation was greatest very shortly after the onset, as was apparently the case with the diplopia, but no opportunity presented itself to verify this, for no case was seen earlier than the third day of the illness.

2. *Paresis of the iris* occurred in one eye of one case; it was of medium severity.

3. *Diplopia*.—This occurred in all the four cases given in detail, as well as in the five more casually mentioned. Three still had it when seen. Two of them had paresis of one muscle served by a branch of the third nerve, but Case II showed a relative convergence not due to paresis of a muscle, for it was equal in all positions. It is better to assume that the convergence was really due to weakened divergence than to spasm of convergence. The onset of

diplopia was sudden, but it became less severe after a few days, so that Case I thought it had gone when she visited me, though this was not so. When examined there was no obvious limitation of movement in the three cases; it required examination by a light and a red glass to demonstrate it, so that this symptom was in miniature.

4. *Optic Neuritis*.—In Case II it was distinctly retrobulbar, with diminished central vision and field and enlarged blind spot. In Case I it is mainly retrobulbar, but has come forward to the disc. But there is no projection above the surface, merely a filling up of the cup, the whole disc being white. The appearance of the vessels in the right eye as they emerged from this was quite unusual, as if they suddenly appeared out of plaster-of-Paris. Case III had a slight swelling in one part of the disc. Unfortunately the fields were not taken in this case. Case V had hyperaemia of the discs. His central vision was normal; circumstances prevented the taking of his fields. Thus, in these few cases, two had definite retrobulbar optic neuritis, and there was a suspicion that Case III and Case V had a slight degree of optic neuritis. As optic neuritis has not often been recorded, it may be accidental that so large a proportion of these present cases had it, as may happen with any special symptom in a small series; but it may be that this symptom is commoner than has been suspected, the state of the patients preventing the detailed examination necessary to establish the diagnosis of retrobulbar neuritis. Or perhaps optic neuritis may be frequent in the type of this disease existing in Devon. The few cases of optic neuritis recorded in France are summarized in *Archives d'Ophthalmologie*, 1920, pp. 423 and 429.

In regard to the geographical incidence, three of these cases occurred in Exeter, the remainder in North Devon. That these cases have come under the notice of an oculist raises the suspicion that there may be others, and that slight cases of this disease may be commoner than is at present thought.

It must be pointed out that the dominant symptoms in this group of cases—paresis of accommodation, diplopia, and sleepiness—are easy to recognize. To test the accommodation exactly may require special apparatus, but if a patient has difficulty in reading come on in two or three days, and this is associated with the other two symptoms, the practitioner will not go far wrong in assuming weakness of accommodation, and in establishing a *prima facie* case for encephalitis lethargica, notwithstanding the pitfalls which surround the subject.

A NOTE ON NEW GROWTH AND A REDUCING SUBSTANCE IN THE BLOOD.

BY

A. S. LEYTON, M.D., AND H. G. LEYTON, M.D.,

CAMBRIDGE.

The theory that a factor was present in the blood which favoured the growth of certain bacteria was at one time commonly held, and was the basis of the old idea of a "diathesis," but when Ehrlich introduced his theories of immunity the older beliefs were mostly discarded and attempts to explain the incidence of disease have been greatly influenced by his teaching.

In common with several other pathologists, however, we have often felt that applications of Ehrlich's theory were limited and did not explain many of the phenomena of disease, and, while searching for further light on these problems of immunity, we tried at one time the effect of transplanting in succession each of the endocrine glands to see if any one of them by their secretions caused or accelerated the growth of tumours, and special interest attaches now to the fact that the only one that appeared to affect the growth of inoculated sarcoma in rats was the parotid.

The bacteria with filtrable spores which can be isolated from tumours have formed the subject of communications elsewhere. Finding that this class of bacteria only thrive well on media containing sugar, we examined the blood-sugar content of patients suffering from malignant disease and found the reducing substances invariably increased. (The picric acid method was used for testing the blood, hence we do not suggest that the figures given represent

only sugar, since other reducing substances may be included. Further, in most of the cases which have been under observation for any length of time a definite excretion of sugar in the urine (as tested by Nylander's fluid) has appeared from time to time. So consistent have been the results that we have recently felt able to rely on this test to differentiate between simple and malignant cases. For example:

1. A fluctuating swelling in the neck, possibly inflammatory, showed reducing substance 0.34 per cent., and proved to be sarcoma.
2. A case with long-continued gastric symptoms, possibly malignant, gave a normal sugar content, and on laparotomy showed only simple ulceration.
3. Two cases diagnosed as tubercle of the lung gave reducing substances 0.24 per cent. and 0.32 per cent. respectively. Both proved to be malignant, whereas other cases of phthisis gave a normal result.
4. A case of acute pain in the pelvis, without obvious cause, gave reducing substance 0.29 per cent., and *post mortem* an annular carcinoma of the rectum was found.

We do not wish at this stage to enter into any discussion as to the relations of the high percentage of reducing substance as cause, effect, or concomitant, but merely to relate that through finding it we were led to try the experiment of feeding rats on sugar after they had been injected with a bacillus with filtrable spores isolated from a case of human sarcoma. This sarcoma was of the melanotic type, but the pigment was scanty.

Injections were made into the tails of eight rats. Three of the animals were large enough for the emulsion to be injected into the tail vein, but in the five smaller rats the injection was subcutaneous. All external evidence of the injection had disappeared in a week, but after five weeks a nodule the size of a split pea was found at the point of injection in one of the small rats. This proved to be mainly a spindle-celled growth with a few giant cells, but some of the cells contained pigment.

One of the large rats died after six weeks and showed extensive growths in both lungs. Microscopically large areas of necrosis were seen with a margin of cells some of which contained pigment. The original sporing bacillus was regained from this growth.

Two large rats remaining alive at the end of two months were killed and found to have nodules of growth in the lungs; one also had a primary nodule in the tail.

Six rats inoculated with the same culture, but not fed on sugar, showed no evidence of growth locally or in the lungs after three months. Six other rats fed on sugar, but not inoculated with bacteria, likewise remained healthy.

In view of the interest of the subject and the fact that rats are so difficult for us to obtain, we shall be pleased to supply a subculture of this bacillus to any cancer research institute that may care to repeat our experiments on a larger scale, and we should like to suggest to those working with simple inoculable overgrowths that they try the effect of feeding the inoculated animals on sugar.

A grant toward the expenses of this investigation was received from the Science Committee of the British Medical Association.

THE PATH OF TOXINS TO THE CENTRAL NERVOUS SYSTEM.

BY

MARTIN BUTTON, F.R.C.S. EDIN.,

RYE, SUSSEX.

THE statement that the infection of the central nervous system probably takes place from the mucosa of the nasopharynx is frequently made, and an examination of the possible routes of such an agent, toxin or whatever it may be, would appear to be of interest as affording a possible explanation of the sequence of phenomena commonly observed.

Two possible routes present themselves: (a) By the blood stream, either directly or after lymphatic absorption; (b) along the nerves. A consideration of the facts would seem to indicate that both routes are made use of.

In the condition encephalitis lethargica we might suppose the toxin to work its way up the motor fibrillae of the facial nerve.

The path through the cribriform plate—in spite of the fact that the nasal lymphatics have been injected from the subdural space, and the short route offered by the nasal nerves as far as the meninges and olfactory nerves through

the meninges—is negatived by the fact that a toxin arriving in the anterior cerebral fossa could hardly manifest itself first by a lesion of nuclei in the tegmental region of the pons.

The facial nerve, supplying the buccinator and labial muscles in relation to the oral cavity, and probably the levator palati and musculus uvulae (lesser palatine branch of sphenopalatine ganglion via vidian, and great superficial petrosal), in relation to the nasopharynx, could afford a mode of entrance. In the substance of the pons the ascending portion is in the closest relationship with the medial longitudinal bundle, and in all probability contributes fibres to that bundle. In addition it embraces the nucleus of the sixth nerve, in much the same manner that the loop end of a hairpin, bent on the flat, might hold a pea in its concavity.

The nucleus most intimately related to the medial longitudinal bundle is the oculo-motor, the cells of which are indeed divided by that bundle into several collections, which have been supposed to preside over separate orbital muscles. Whether the fibres for the orbicularis palpebrarum arise from the oculo-motor and descend to the facial in this bundle, as was supposed by Mendel, or whether they arise in a superior part of the facial nucleus, it is not difficult to believe that the most intimate connexion between the latter nucleus and the third is with that part of the third which presides over the levator palpebrae superioris. The trochlear and abducent nuclei are also, of course, closely placed to the same bundle.

What, then, are the symptoms we might expect from a toxin ascending by way of the facial fibrillae and medial longitudinal bundle? They are facial paralysis, ptosis, abducent or other ocular paralysis. In fact, the localizing signs commonly found in encephalitis lethargica.

MacNalty has suggested¹ that the stupor in this condition is occasioned by the cutting off of the afferent sensory stimuli, by involvement of the medial lemniscus, owing to its proximity to these medial somatic nuclei in the tegmental region.

I would submit that, in the region of the third nucleus, the medial lemniscus is pushed some distance laterally by the nucleus ruber; also that the lateral lemniscus, conveying auditory impressions, would not be involved; and that the lesions, though bilateral, are usually asymmetrical, so that one half of the sensory tract would probably be but slightly damaged. Therefore, one could hardly suppose that the afferent stimuli could be so entirely cut off as to produce the degree of lethargy observed. In fact, the type seen more approximates to that produced by drugs.

It would seem easier to explain it on the assumption that it was the general effect on the cerebrum of the toxin absorbed by the blood stream. There could hardly be doubt that toxin so absorbed would reach the cerebrum far more rapidly than it could travel up the nerves; but that it would be diluted by the total amount of blood in the circulation, come in contact with a greater amount of antibody, and would be supplied in equal amount to all the body cells. To suppose that, distributed in this way, it could pick out individual cranial nuclei would necessitate the assumption of a special affinity of certain motor cells for a particular toxin, and that such affinity was not possessed by other motor cells serially homologous and structurally identical—a hypothesis which does not commend itself.

Group 1, therefore, in which we have lethargy and asthenia but no localizing signs, might be supposed to be caused by absorption from the blood stream, in which death or recovery takes place before sufficient toxin has ascended by the nerve paths to cause such signs. The succeeding groups are those in which we have the effects of both in varying degrees.

The twelfth nucleus may be affected either by spread along its own fibrillae or from its connexion with the medial longitudinal bundle. Professor Marinesco, in the report quoted, expresses the opinion that the toxin travels by the way of the nerves. I have merely endeavoured to find an anatomical explanation for the sequence of events.

If we apply this hypothesis to the conditions met with in diphtheria, we have the causative organism living, and pouring out its toxin, on the walls of the pharynx and larynx, separated by a devitalized mucosa from muscles innervated by the cerebral part of the accessory (by way of branches of the vagus to the pharyngeal plexus). Toxins ascending along the fibrillae of these nerves would

be conducted to the nucleus ambiguus, which also contributes to the vagus motor fibres for the heart. This would explain the association of dysphagia, and regurgitation of food through the nose (paralysis of the palatopharyngei), with cardiac disturbance—an association commonly met with in post-diphtherial paralysis.

I saw an interesting example of the association of these nerve paths in a case of paroxysmal tachycardia. The patient, in the early stages, was sometimes able to cut short the attack by the act of swallowing—a reflex action in which the nucleus ambiguus would be predominantly concerned.

Turning to the problem presented by tetanus, we find two points in which there is a contrast with the conditions previously discussed. In the first place, the effect of this toxin upon the motor cells, if indeed its effect be upon those cells, is the reverse of paralysis; it produces increased excitability with increased output. This phenomenon is more readily interpreted as due to interference with the inhibition normally imposed upon external stimuli reaching the motor cells from the sensory side; so that the paralysis probably occurs somewhere in the reflex arc, between the synaptic endings of the afferent nerves round the cells of their terminal nuclei and the dendrites of the motor cells.

Secondly, it would seem that the toxin does not ascend along the fibrillae; for if that were the case the muscles of the reflex arc, along which it travelled, would, it might be expected, be the first affected. Presumably, then, it makes its way beneath the sheath, and on reaching the spinal medulla may be supposed to ascend beneath the membranes. When it is remembered that the motor nucleus of the trigeminal nerve derives most of its sensory stimuli from the terminal nucleus of the trigeminal afferent fibres, alongside which it lies; and that the tractus spinalis comes to the surface in the postero-lateral area of the inferior part of the medulla oblongata, in the region known as the tuberculum cinereum of Rolando; and that a toxin ascending beneath the meninges might be conducted up that tract, reason can be seen for what is otherwise difficult to understand—namely, why trismus should be the earliest, and in mild cases the only, manifestation of a toxæmia which, when sufficiently prolonged, affects the whole motor mechanism.

REFERENCE.

¹ Report on Encephalitis Lethargica, Local Government Board, New Series No. 121.

Memoranda:

MEDICAL, SURGICAL, OBSTETRICAL.

A CASE OF SUDDEN MONOCULAR DILATATION OF THE PUPIL.

The notes on the following case afford a striking example of how a purview of all the facts in connexion with a case, both relevant and apparently irrelevant, may help towards establishing a diagnosis, and how a quite justifiable absence of knowledge of an apparently irrelevant factor may cause failure to make a diagnosis.

A medical practitioner recently sent me a lady who had suddenly developed complete dilatation of the left pupil, accompanied by supraorbital neuralgia, some apparent slight paresis of the upper lid, and some nasal catarrh.

The condition came on after a cold motor drive. It had caused the practitioner some alarm, and he, in my opinion quite rightly, regarded it as a case for investigation. The possibilities were many and various, and the condition might well have been the precursor of serious nerve lesion.

When I saw her every trace of abnormality had disappeared; the eye was normal in appearance and function, the musculature of the eye, extrinsic as well as intrinsic, acted normally; the nasal mucous membrane was healthy and normal. I was convinced that some mydriatic had got into the eye, but there was no history of any "drops" of any kind having been used. I was not satisfied, and after an examination I elicited the fact that she had a sprained knee, that she had consulted another medical practitioner about this in another town, and that she had been given a liniment to rub the knee. She did

not know what the liniment was, but said that it contained "ammonia." The practitioner who sent her to me was not aware of this condition of the knee.

She told me that she had the prescription at home, and I asked her to go home and to telephone to me if it contained the word "belladonna." She rang me up in half an hour. The prescription contained belladonna, and the case was now clear. Unquestionably she had conveyed some of the liniment into her eye.

The case was not one in which I consider that I am entitled to credit, nor the practitioner who sent her to me to discredit; but I learnt a lesson and I pass it on as possibly being of value to others.

The accompanying supraorbital neuralgia, which had evidently not been severe, may have been due to the action of light (it was bright weather) on the relatively unprotected retina, and I have no doubt that the drooping of the eyelid was due to the unconscious lowering of the lid to shut off excessive light. I met the lady a few days later; there had been no further trouble.

PETER MACDONALD, M.D.,
Senior Honorary Ophthalmic Surgeon,
York County Hospital.

THE FORMOL-GEL REACTION IN SYPHILIS.

It has been said that "the performance of the Wassermann test involves one of the most complicated methods that have been applied to diagnosis in medicine,"¹ and many laboratory workers must have hoped that some day a simpler and more direct method of diagnosing syphilis would be found.

The *formol-gel reaction* recently discovered by Gaté and Papacostas² gives promise of reducing the diagnosis of syphilis to a degree of simplicity altogether unexpected. The method is as follows:

One cubic centimetre of the serum to be tested is placed in a test tube, two drops of formalin (40 per cent. formaldehyde) are added and the tube is shaken to mix the contents. After standing at room temperature for twenty-four to thirty hours the tubes are examined and the results read. A positive serum is found to have coagulated into a firm jelly, while a negative serum remains fluid. Gaté and Papacostas found that, in a series of over 400 serums examined, the results corresponded with Wassermann results in 85 per cent. of cases.

I have had opportunity so far of testing only a small number of serums by this method, and the results are given in the following table.

	Formol-gel.		Wassermann.	Condition of Serum.
	Fresh Serum.	Heated Serum.		
1		+	+±	Jellied.
2		±	+±	Semi-liquid.
3	++		++	Firm jelly; tube can be inverted.
4	—	—	—	Liquid.
5	—	—	—	Liquid.
6	—	—	—	Liquid.
7	—	—	—	Liquid.
8	±	—	+±	Semi-liquid.
9	—	—	—	Liquid.
10	—	—	—	Liquid.
11	—	—	—	Liquid.
12	++	++	++	Firm jelly; tube can be inverted.
13	—	—	—	Liquid.
14	—	—	—	Liquid.
15	—	—	—	Liquid.
16	—	—	—	Liquid.
17	++	++	++	Firm jelly; tube can be inverted.
18	—	++	++	Firm jelly; tube can be inverted.
19	—	—	—	Liquid.
20	—	—	—	Liquid.
21	—	—	—	Liquid.
22	—	—	—	Liquid.
23	—	—	—	Liquid.

The following notes have been made during the tests:

1. The test tubes employed should be of the same internal diameter, so that the results may be strictly comparable.
2. A diameter of half an inch has been found the most suitable for use with 1 c.cm. of serum.
3. The amount of serum for a tube of this diameter should not be less than 1 c.cm. If less than this amount is used the result is obscured by capillary attraction.
4. In the case of a strongly positive serum there is definite coagulation into a firm jelly, which remains unbroken when the tube is completely inverted or even roughly handled—for example, thrown upon a table.

¹ Med. Res. Com. Spec. Report, Series No. 21.
² C. R. Soc. Biologie, November 20th, 1920.

5. A negative serum remains quite liquid, and "runs" when the tube is tilted.

6. In serums intermediate between strong positive and negative the reaction is less definite, but, generally speaking, the degree of coagulation appears to correspond to the degree of positiveness or otherwise.

7. Coagulation, when present, tends to become more marked the longer the tubes are allowed to stand—for example, a tube that was read as ± after thirty hours became a + after standing for nine days; this fact might be made use of in determining the finer grades of positive and negative.

It would be premature to form any definite conclusions on such a small series of tests, but the results obtained are sufficiently striking to show the potentialities of the method, and to give rise to the hope that this rival of the Wassermann test may lead to a simple and reliable method of diagnosing syphilis.

J. MACKENZIE, M.A., M.B., Ch.B., D.P.H.,

District Laboratory, Shorncliffe.

Major R.A.M.C.

Reports of Societies.

THE LARYNGOLOGICAL SUMMER MEETING.

THE Section of Laryngology of the Royal Society of Medicine held a highly successful summer meeting at the House of the Royal Society of Medicine on Thursday, June 2nd, and Friday, June 3rd, 1921. The President, Dr. JOHNSON HORNE, was in the chair, and there was a very satisfactory attendance, a large number of the Scottish and provincial members of the Section being present, undeterred by the difficulties of travel at the present time, in addition to a number of distinguished foreign and colonial visitors.

The meeting was opened on Thursday afternoon by the PRESIDENT, and Mr. MARK HOVELL thereafter read a paper on the indications for and against complete tonsillectomy as a routine operation, which was followed by an interesting discussion. Mr. Mark Howell held that enucleation of the tonsils for enlargement was unjustifiable, and, although he was supported by Professor BURGER of Amsterdam, who considered that tonsillotomy in children was better than tonsillectomy because it did not require anaesthesia, yet the other speakers were practically unanimous in favour of tonsillectomy as against tonsillotomy. Mr. ROSE, although he disagreed with the idea of leaving tonsillar tissue behind, thought the scarring after the complete operation was a great disadvantage, especially to singers; Mr. FAULDER, on the other hand, considered that singers were worse off with septic tonsils than with scars. Sir WILLIAM MILLIGAN, who thought the allegation as to scarring exaggerated, was of opinion that the complete operation was absolutely necessary, and Mr. STUART LOW agreed that if the tonsil was diseased it ought to be removed. Mr. HOLR DIGGLE stated that he had found that many tonsils which could not be diagnosed as such clinically were in fact tuberculous. Mr. O'MALLEY considered that the fear of haemorrhage ought not to weigh against the operation of tonsillectomy, as he had found that the number of cases published of haemorrhage was greater in the period when tonsillotomy was practised than in the tonsillectomy period of the last eleven or twelve years. Mr. HERBERT TILLEY said that he had passed through all the stages and he now enucleated tonsils by dissection only.

Mr. WALTER HOWARTH described the operation he practised on the frontal sinus. In the discussion which followed on the relative value of the external and the intranasal operations on the frontal sinus the merits of Mr. Howarth's contribution were acknowledged. Sir STCLAIR THOMSON, in a paper on the usual site of origin of intrinsic cancer of the larynx, said that his experience of fifty laryngo-fissures now led him to believe, contrary to his former opinion, that the usual site was the anterior and middle thirds of the vocal cords. The paper was illustrated by drawings and specimens shown on the epidiroscope.

In the morning session next day the papers were mainly of technical interest. Dr. LOGAN TURNER opened with a paper on paralysis of the vocal cords in cases of malignant tumours of the mamma, and Sir WILLIAM MILLIGAN followed with an exposition of his methods of practising diathermy in inoperable pharyngeal and epiglottic malignancy. Dr. IRWIN MOORE's paper on eversion of the sacculus laryngis, the so-called prolapse of the

ventricle, started an animated discussion, which, however, did not obscure his thesis that the so-called prolapse was in reality an eversion of the caecal appendix called the sacculus.

Mr. HOBDAY then read an interesting contribution on the results of over 2,000 cases of vocal cord paralysis in horses treated by the stripping of Morgagni's ventricle. Mr. Hobday practised this operation for the relief of roaring and whistling horses, and he suggested that it might be useful in the treatment of bilateral paralysis in man for which at present tracheotomy was all that could be done. In the discussion that followed, however, it was remarked that the conditions in man which gave rise to bilateral paralysis were usually of such a serious and advanced nature that it was doubtful if Mr. Hobday's operation could be satisfactorily performed, while Mr. VLASTO pointed out additional difficulties in technique to which the slight anatomical differences gave rise. Mr. TILLEY probably expressed the opinion of the meeting when he said that there were certain comparatively rare conditions in which the operation might well be tried.

The last paper in the morning session was by Mr. SYME, on bronchospasm in the treatment of asthma; in a series of 23 cases he had had in 12 alleviation of the symptoms after the application of a 10 per cent. solution of silver nitrate to the bronchi by the aid of the bronchoscope. A subsequent speaker stated that the passing of the bronchoscope into each lung without any application had been of benefit in asthma, but in his reply Mr. Syme stated that he had done so, and had also used other applications, without the benefit which silver nitrate had given.

In the afternoon a number of demonstrations were given by Dr. MORTON on some recent developments in X-ray treatment for laryngeal cases; by Dr. MULALLY on the technique of blood transfusion; and by Mr. LAYTON, who demonstrated some specimens from the Onodi collection. The afternoon session was followed by the ordinary clinical meeting of the Section of Laryngology, when Dr. DOUGLAS GUTHRIE showed a specimen of a collar stud which in the oesophagus of an infant had caused osteomyelitis and death. Dr. CUPLEY demonstrated new tracheotomy instruments; Sir STCLAIR THOMSON showed a number of cases of tuberculosis of the larynx in which good results had followed treatment with the galvano-cautery; and Dr. FREDERICK SPICER showed a case of laryngocoele after operation, which he had previously shown last year and which gave rise to considerable discussion. Other cases were shown by Mr. JEFFERSON FAULDER, Dr. DAN MCKENZIE, Mr. O'MALLEY, and Dr. ELEANOR LOWRY. In the evening a very successful dinner was held at the Trocadero Restaurant, at which Professor Burger of Amsterdam, Sir Frank Colyer, Sir Charles Gordon-Watson and other guests were present, and on Saturday morning a number of special operations were performed at University College Hospital by Mr. Herbert Tilley and others.

An interesting ceremony in connexion with the Summer Meeting took place on Sunday, June 5th, when a number of representative laryngologists met at Wargrave to place a laurel wreath on the grave of Sir Morell Mackenzie in the churchyard there. The members of the Section and other guests were invited to lunch by Dr. Irwin Moore, who lives at the house in Wargrave which was formerly Sir Morell Mackenzie's, and thereafter they walked in procession to the churchyard, where they were met by the vicar, who held a short memorial service. The laurel wreath was placed on the grave by Mr. Mark Howell and Dr. Donelan, both old pupils and house-surgeons of Mackenzie's, and Mr. Mark Howell made an oration on the qualities of Sir Morell Mackenzie as a man, and told of the long battle against ill health which the great laryngologist had had, of his innumerable acts of private charity, and of his many achievements. Sir STCLAIR THOMSON then spoke of him from the professional point of view as the "father of laryngology," and said that, following Lamb's advice, whenever a new book on laryngology was published he read Mackenzie's old book, and there found many of the so-called new ideas. Sir JAMES DUNDAS GRANT also spoke, referring to the fact that a commemorative tablet had been placed on the house at Leytonstone where Morell Mackenzie was born. The villagers of Wargrave crowded into the old churchyard, and the village choir led the singing of appropriate hymns. In the background were the two surviving daughters of Morell Mackenzie, and

Mr. Gustave Garcia, son of the great Manuel Garcia, stood near. Round the grave of the pioneer of the science who had been dead for nearly thirty years were grouped, with bowed heads, most of those whose names are best known in laryngology to-day, and there, in the brilliant sunshine of the summer afternoon, the touching little ceremony ended.

CARDIAC MASSAGE.

At a meeting of the Section of Surgery of the Royal Society of Medicine, held on June 1st, Dr. A. GOODMAN LEVY read a communication on cardiac massage. He claimed that consistently successful results—at least in the case of cats, though not in the case of dogs—had been obtained in the laboratory, and therefore the results obtained when dealing with the human subject ought to be much better than they were, even allowing for the fact that the completeness of laboratory control was not possible. Successes were recorded, but failures were so many as almost to bring the method into disfavour. The purpose of cardiac massage was to create an artificial circulation; the procedure employed was purely mechanical, and must be combined with an efficient method of artificial respiration. Success was rarely possible without this accompaniment, and to justify cardiac massage both the surgeon and the anaesthetist should be thorough in all that they did. The term "massage" was inappropriate; it was not a massage of the muscular tissues of the heart which was intended, but an effective rhythmical compression of the heart, including the expulsion of the contents of both ventricles, for he had not found his attempts successful unless the right ventricle as well as the left received attention. He discussed the various methods of access; in nearly all the successful cases pressure was applied under the diaphragm, not involving the incision of the diaphragm, as in the transdiaphragmatic method, but success had been claimed for the thoracic route also. There was no question at all as to the adequacy of massage to restore the beat of a heart over-dosed with chloroform, but syncope from primary cardiac failure introduced other considerations. Not more than two minutes should be allowed for the chance of spontaneous recovery with primary cardiac syncope, and after that time massage should proceed without hesitation. A point of some importance in the procedure was intermittency. If the massage was not successful after ten minutes, the action should be intermitted by intervals of rest, from fifteen seconds increasing to forty-five seconds, and it would often be found that during the rest period or on resumption of massage following it the heart recovered. A table of times shown by Dr. Levy indicated that the duration of massage before recovery occurred was very variable, and apparently had no relation to the interval between the moment of syncope and the commencement of massage.

The lateness of the hour ruled out almost all discussion upon Dr. Levy's paper, but there was time for one member of the Section to suggest that the good results were solely due to the artificial respiration given concurrently with the massage, and would be forthcoming just the same if the massage were omitted.

THE Société Belge de Neurologie et de Psychiatrie recently celebrated its twenty-fifth anniversary at Brussels, when the subject for discussion introduced by Drs. Ley and Alexander was the psychological and anatomical study of senility.

THE forty-first annual meeting of the Ontario Medical Association was held at Niagara Falls, from May 31st to June 3rd, and the Canadian Society of Anaesthetists, the Interstate Association of Anaesthetists of America, the Ontario Radiological Society, the Canadian Radiological Society, and the Ontario Hospitals Association held meetings concurrently. Besides addresses on surgery by Dr. Starr Judd, and on medicine by Dr. Frank Billings, there were sectional meetings and discussions on medicine, surgery, obstetrics and gynaecology, radiology, ophthalmology, and oto-rhino-laryngology, and a scientific exhibit with special demonstrations. There were three dinners, at one of which the President of the Association, Dr. Hezner Mullin, spoke, and at another the President of the Trades and Labour Congress of Canada, while many other social attractions were arranged.

Rebicus.

OPERATIVE SURGERY.

WE are glad to welcome the third edition of the manual of *Operative Surgery*,¹ by THOMSON and MILLS, which is a companion volume to the *Manual of Surgery* by the same authors. Any disappointment with which the surgical profession received the first edition has been completely dissipated by the admirable production now before us; its scope is considerably wider than that of the first edition, and we are sure that the volume will appeal to all classes of the profession not only on its own merits but also from the fact that it may be regarded as thoroughly representative of the surgery of the Edinburgh school. The book is divided into two sections—general and regional; the former deals with surgical technique, anaesthetics, and general considerations as to amputations and operations on blood vessels, nerves, bones, and joints; the latter part is concerned with operations on the various regions. It is significant that in the chapter on anaesthetics the description of the action and mode of administration of ether takes precedence of that of chloroform, and occupies five times the number of pages. The general discussion on the various anaesthetic substances is very fair-minded, the claims of each being presented fully and adequately, with, on the whole, a preference for open ether. The up-to-dateness of the book may be realized from the introduction in the chapter dealing with transfusion of blood, of Moss's classification of blood groups. Following the plan adopted in the first edition, each chapter in the regional part of the book is preceded by a succinct anatomical description of the parts to be dealt with. This anatomical introduction is apt by some authors to be overdone, but any reader of this work will agree that the interest of the descriptions of the operations is greatly enhanced by the short anatomical sketch of the parts involved. We note with a certain measure of regret that in these anatomical descriptions the new nomenclature seems to be generally employed, though in each instance the old nomenclature appears alongside. Illustrations are plentiful but by no means redundant, and they are of high quality. A few errors in the letterpress have crept in (page 37 line 37, page 432 line 13, page 529 line 10), while the clamp shown in the picture illustrating Mitchell's operation for piles is not Mitchell's clamp but an ordinary transverse serrated forceps. These are, however, small blemishes in a most excellent work, and are indicated simply for the purposes of alteration in the next edition. The book is one which can be very heartily commended to practitioners, operating surgeons, and men preparing for a fellowship examination; its production reflects the highest credit not only on the authors but also on the publishers.

WE were able to welcome the first English edition of SCHMIEDEN'S *Operative Surgery*² with commendatory words. The second edition is somewhat enlarged, and apparently an effort has been made to make the work less of an operative surgery class-room book and more like a volume of value to the practitioner and the surgeon. To a very great extent, however, the book remains more suitable for the student taking a course of operative surgery than for the practising surgeon. The illustrations, though well drawn, are more helpful when operating on the cadaver than on the living subject. The book appears to be popular in Germany, as six editions have already appeared. The observations in the translator's introduction are, on the whole, somewhat trite, and one has difficulty in comprehending the meaning he desires to be attached to two diagrams consisting of a series of seven black dots labelled stomach, heart, lung, etc., connected together in one instance by a dotted line and in the other by a plain

¹ *Operative Surgery*. A companion volume to a *Manual of Surgery*. Vols. I and II. By Alexis Thomson, F.R.C.S. Edin., and Alexander Mills, F.R.C.S. Edin. Third edition. London: Henry Frowde, and Hodder and Stoughton. 1920. (Cr. 8vo, pp. 637; 279 figures, 16s. net.)

² *The Course of Operative Surgery*. A Handbook for Practitioners and Students. By Professor Dr. Victor Schmieden, Professor of Surgery in the University of Halle, and Arthur Turnbull, M.B., Ch.B. (Glasg.) lately Demonstrator of Anatomy in the University of Glasgow. Second enlarged English edition. 1920. London: Baillière, Tindall, and Cox. (Roy. 8vo, pp. xx+350; 436 figures, 25s. net.)

line. The translator describes two cases in which mistaken diagnosis was made, and remarks that "a more scientific outlook is to regard the body as reacting as one whole to disease or infection or external changes, and to interpret particular symptoms . . . not as pointing to any one organ as the cause of the particular illness . . . but rather as the localized signs, interruptions, diminutions and exacerbations of the general condition." This, of course, is what we all know, and is constantly before the mind of every teacher. On the whole we do not think that this book approaches, in excellence or usefulness to the practitioner and student, many books on operative surgery published by British authors.

A SERUM TEST IN SYPHILIS.

DR. ARTHUR VERNES'S *Atlas de Syphilimétrie*³ contains much that is of interest to the syphilologist and much that will require careful investigation before a definite opinion can be given of its value. The author has elaborated a special serum test for syphilis, which he claims is not only useful for diagnostic purposes, but is especially valuable as a means of controlling treatment and of verifying cure. The test is a very elaborate one, and it is impossible to furnish a complete description. Briefly stated, the basis of it is as follows: When a substance which the author calls "perethynol" (a fluid containing an infinite number of ultra-microscopic granules in suspension) is added to any human serum flocculation takes place—that is, the granules congregate into masses, microscopic at first, but later becoming visible to the naked eye. Perethynol is an ethylene perchloride and alcohol extract of horse's heart. In syphilis this flocculation is more marked and is proportional to the intensity of the infection. A single test is of little value, but by making a series of tests a curve may be formed, the curve of a syphilitic being very different from that of a normal person. The author has discovered that pig's serum is "antiflocculent," opposing the formation of granules. On the other hand, pig's serum is haemolytic for sheep's red corpuscles. What is of interest is the fact that in exercising the antiflocculent property pig's serum loses its haemolytic action. The application of this is evident. Perethynol, human serum, pig's serum, and, later, sheep's corpuscles, are added together. In proportion as the pig's serum prevents flocculation it loses its power of haemolyzing the corpuscles, so that the latter are completely, partially, or not at all haemolyzed. The degree of haemolysis is found to correspond to the intensity of the syphilis, being complete with a normal serum and almost nil with a powerful syphilitic one.

The results of a series of tests are recorded graphically. Injections of arsenical preparations are also found to exercise an action on the flocculating power of the blood, and Dr. Vernes claims that his reaction enables treatment to be controlled in a completely satisfactory manner.

It is difficult at the present moment to estimate the value of Dr. Vernes's observations. Up to now they have only been tested in a few laboratories in England, and much work will have to be done on the subject. The technique of the reaction appears to be somewhat difficult, and requires the services of a highly skilled pathologist. Dr. Vernes's *Atlas* is written in a lucid style, and is most excellently illustrated by means of numerous charts.

BACTERIOLOGY.

THE seventh edition of Professor HEWLETT'S well-known *Manual of Bacteriology*,⁴ while preserving the general features of former editions, has been revised and brought up to date, so as to include reference to, amongst other things, the serological types of the pneumococcus, Holman's classification of streptococci and infections by paratyphoid C. The section dealing with spirochaetal infections contains an account of Noguchi's recent work on yellow fever, and some of the other sections have been revised where necessary. A full description is now given of the technique of Fildes and McIntosh for carrying out the Wassermann reaction. When a subject is developing so rapidly and on

so wide a front as bacteriology, the task of writing a satisfactory textbook is particularly difficult, since an edition is no sooner published than inevitably it begins to grow rapidly out of date.

Professor Hewlett's volume is the work of a teacher of great experience; the printing and illustrations are excellent; the subject matter is well set out and the diction is extremely clear and comprehensive, so that the book is, perhaps, the most readable of all the bacteriological textbooks in English. These characters have justly gained for it a wide popularity. The following criticisms are offered in a constructive spirit. The book now runs to over 800 pages—surely some compression could be effected without materially reducing its value? On general grounds it seems a pity to label Welch's bacillus by its later Continental name of *perfringens*. While Wassermann's reaction is fully dealt with, we see no reference to the far simpler Sachs-Georgi reaction, which is making such rapid strides on the Continent as a check, if not eventually as a substitute, for the more complicated and difficult Wassermann test. Finally, we should like to see a rather more full description of the present state of knowledge concerning filtrable viruses: Lipschütz's classification of them, given in Kolle and Wassermann's *Handbuch*, is well worthy of mention in the next edition of one of the leading textbooks of bacteriology in this country.

TYPHUS FEVER IN SERBIA.

THE monograph entitled *Typhus Fever, with Particular Reference to the Serbian Epidemic*,⁵ by Dr. RICHARD P. STRONG and colleagues, contains a full account of the work of the American Red Cross in connexion with the suppression of the typhus epidemic in Serbia. The book is divided into four parts. The first, which is written by Dr. Strong, contains a general account of typhus fever, with particular reference to the Serbian epidemic of 1915, followed by a description of the Polish epidemic of 1916. A vivid account is given of the deplorable conditions prevailing in Serbia shortly after the arrival of the American Red Cross. "The conditions in many of the hospitals were about as bad as they well could be. There was no lavatory or bathing or toilet facilities for the patients, no clean linen or clothing for them, and no systematic disinfection of such linen or the beds. There were usually no nurses and often only a few Austrian prisoners as attendants. . . . Under such conditions the mortality was naturally great, and reached in some instances as high as 70 per cent." As a result of the establishment of an international sanitary commission, consisting of American, British, French, Russian and Serbian representatives, the country was divided into sanitary districts, to which were attached sanitary personnel, sanitary stations and hospitals, and an active antityphus campaign was carried out. The epidemic was brought to an end by the efforts of the Serbian medical and sanitary officers and other officials and the Serbian people themselves, working with the foreign detachments. In his account of the Polish epidemic Dr. Strong declares that the antityphus campaign is not being prosecuted by the Polish Government in an energetic and satisfactory manner, and that if the world does not fight typhus in Poland it may soon have to fight it in other countries as well. The second part, which is written by Dr. SUATUCK, is devoted to a description of his clinical observations on typhus fever in Serbia in 1915, and may be said to be the most complete account of the disease given since Murchison. Of the cases observed, 100 were studied in detail, autopsies being performed in 20 cases; 42 cases are related in full. The third, fourth and fifth parts, written by Drs. SELLARDS, ZINSSER, and HOPKINS respectively, give an account of the laboratory work carried on in Serbia. The absence of any mention in this part of the work of the Weil-Felix reaction, which plays so important a part in the laboratory diagnosis of typhus, is to be explained by the fact that in 1915 its value had not been recognized. Moreover, as Dr. Strong points out, during the severe period of the epidemic the number of patients admitted into the hospitals were so numerous that the use of any such methods would have been precluded.

³ *Atlas de Syphilimétrie (100 Graphiques). Les Conditions Expérimentales de l'Extinction de la Syphilis.* By A. Vernes, Paris, F. P. Alcan, 1920. (11 x 7; pp 121. Fr. 35.)

⁴ *A Manual of Bacteriology.* By R. Tanner Hewlett, M.D., F.R.C.P., D.P.H. Seventh edition. London: J. and A. Churchill, 1921. (Demy 8vo, pp. 817; 68 figures, 21 plates. 21s. net.)

⁵ *Typhus Fever, with Particular Reference to the Serbian Epidemic.* By R. P. Strong, M.D., G. C. Shattuck, M.D., A. W. Sellards, M.D., H. Zinsser, M.D., J. G. Hopkins, M.D. Published by the American Red Cross at the Harvard University Press, 1920. (Imp. 8vo, pp. 278; 26 plates.)

Diagnosis from clinical manifestations was the only method possible under such circumstances.

The writers are to be congratulated upon having produced, not only a worthy memorial of the achievements of the American Red Cross, but also an important contribution to the medical history of the war.

DIABETES.

PROFESSOR MARCEL LABBÉ has collected his clinical lectures and papers contributed to various journals on the subject of diabetes mellitus into a volume.⁶ The result is a series of chapters which do not form a very coherent whole. The main point on which the author insists is the recognition of two varieties of diabetes, which he designates *le diabète sans dénutrition* and *le diabète avec dénutrition*. The distinction between the two was formerly expressed in terms of the patients' appearance, "fat diabetics" and "thin diabetics." Professor Labbé contends that the true distinguishing feature is that in the former condition it is the carbohydrate metabolism alone that is deranged, whilst in the latter the protein metabolism is involved also. The clinical description of the disease is admirable, and illustrated by full accounts of cases with painstaking analyses of intake and output. The treatment is discussed at considerable length, but it is unfortunate that this portion of the work is not brought sufficiently up to date to include any mention of Allen's observations and suggestions.

The complications of diabetes are dealt with very fully, and there is an excellent chapter on surgery in diabetics, in which special stress is laid on the choice of anaesthetics. Spinal anaesthesia is the method to be employed for preference, but if a general anaesthetic is unavoidable, ethyl chloride is recommended. It must be admitted that on the whole the book does not advance our knowledge of the causation and prevention of diabetes very far. The records of deranged functions as manifested by abnormalities in excretion are singularly full, but these records do not shed much new light. The principal value of Professor Labbé's discussion of diabetes is to emphasize the necessity for investigation of the disturbances of protein metabolism, instead of, as in the past, concentrating attention too exclusively on the fate of carbohydrates in the body.

THE ART OF DINING.

THE selection of writings to be included in the series of Pilgrims' Books is being made with excellent judgement. The last volume we have seen, *The Art of High Health*,⁷ consists of extracts from WALKER'S *Original*, and a translation of Cornaro's "Sure method of attaining a long and healthful life." Cornaro was born in Venice in 1467 and died in Padua in 1566. His treatise is well known and has a distinct place in the history of dietetics; he was probably the first to use the balance in the study of that subject, and was the advocate of a low mixed diet, consisting of 12 oz. of solid food and 14 oz. of wine a day. Walker was a London stipendiary magistrate who started a weekly paper, *The Original*, the publication of which was stopped after six months, owing to the onset of what proved to be the writer's last illness. Walker's views as to health are remarkable rather for sound common sense than originality. Cornaro apostrophized "O sacred and beneficent Moderation," and Walker was for that Goddess in all things. "Anxiety and quackery," he says, "are destructive of health, but a reasonable attention is absolutely necessary." He mentions what must be a very early instance of a line of treatment now popular, relating how a physician, called to a young lady subject to dreadful fits, "found out that her teeth were in such a state as effectually to prevent mastication; he adopted the strong measure of causing all her teeth to be drawn and a fresh set put in, from which time she completely recovered." Walker's "Aristology or the Art of Dining," which forms the second part of the volume before us, shows that while on hospitable thoughts intent he was an advocate of simplicity. Sir Henry Thompson, famous during the last quarter of the nineteenth century as a medical host, had

without doubt studied Walker. Thompson had seven guests at his "octaves," and Walker wrote: "Eight I hold to be the golden number, never to be exceeded without weakening the efficacy of concentration." A dinner Walker gave at a tavern at Blackwall consisted of turtle soup with cayenne and "lemons cut in halves not in quarters," whitebait with brown bread and butter in abundance, grouse, apple fritters and jelly, ices, a good dessert, coffee and one glass of liquor; with the soup, iced punch; with the whitebait, iced champagne; and with the grouse, claret: "I shall permit no other wines unless, perchance, a bottle or two of port if particularly wanted, as I hold variety of wines a great mistake." Such a dinner would have suited Thompson's ideas well: both he and Walker looked on dinner as an occasion for talk among guests asked, as the latter says, for some reason, "for people brought together unconnectedly had, in my opinion, better be kept separate." But Walker could be a great deal simpler than this, and would invite friends to share his dinner of herrings, hashed mutton and cranberry tart. Walker's governing idea was that, given simplicity, not necessarily divorced from elegance, the best digestives were tranquillity of mind, leisure and agreeable company. Who shall gainsay him?

NOTES ON BOOKS.

THE *Essentials of Medicine* in Lippincott's Nursing Manuals has been written by Professor C. P. EMERSON⁸ for students beginning a medical course, for nurses, and for all others interested in the care of the sick, in clear and simple language, and is copiously illustrated and provided with an ample glossary. Professor Emerson is well known as the author of a good book on *Clinical Diagnosis*, and his elementary exposition of medicine for nurses and others has the essentials of success.

Mr. GORDON SAMSON'S book, *Every Man His Own Builder*,⁹ first appeared in 1912, and the third edition is offered to the public at a time when housing is an urgent problem. The author is an architect, and his object is "to show how any man of normal bodily strength can at need build his own house without the aid of skilled labour." His book is written in plain language and every process is illustrated by explanatory sketches, and a wealth of plans and elevations, intended to ease the task of the amateur builder unversed in the technicalities of professional house designers and builders. In the present edition a table printed in red ink shows the increases in the cost of common building materials at the close of 1920 compared with the prices ruling in 1914.

The general medical reader will find Mr. F. W. RAYNES'S treatise on *Domestic Sanitary Engineering and Plumbing*¹⁰ a good deal fuller and more technical than he is likely to need for ordinary professional or household purposes; but it contains much that is of interest to students of sanitary science and those engaged in public health administration. The main subjects dealt with are indicated in the subtitle; they are domestic water supplies, pump and hydraulic ram work, hydraulics generally, sanitary work, heating by low pressure, hot water systems, and external plumbing. The book is thus intended mainly for students of domestic sanitary engineering and plumbing, and for those whose business it is to design, supervise, or carry out work in this branch of engineering. It is copiously illustrated with drawings, tables, formulae, and worked examples. Chapters VI, VII, VIII, IX, and X are those that especially concern the medical sanitarian; they give a straightforward account of modern drainage work and domestic water supplies from the standpoint of the practical engineer.

⁶ *Essentials of Medicine: A Textbook of Medicine for Students beginning a Medical Course, for Nurses, and for all others interested in the Care of the Sick.* By C. P. Emerson, M.D., Professor of Medicine, Indiana University. Fourth edition, revised. Philadelphia and London: J. B. Lippincott Co. 1920. (Demy 8vo, pp. 412; 117 figures. 12s. 6d. net.)

⁹ *Every Man His Own Builder. A Book for Everyone who Owns a Piece of Land.* By G. G. Samson. Third edition, revised. London: Crosby Lockwood and Son. 1920. (Demy 8vo, pp. 362; 292 figures. 15s. net.)

¹⁰ *Domestic Sanitary Engineering and Plumbing.* By F. W. Raynes. Second edition. London: Longmans, Green and Co. 1920. (Med. 8vo, pp. 487; 277 figures. 21s. net.)

THE publication of Mr. Walter Verdon's book, *Angina Pectoris*, has been transferred to Messrs. Baillière, Tindall, and Cox, of 8, Henrietta Street, Covent Garden, W.C. 2.

⁶ *Le Diabète Sucré.* By Marcel Labbé, M.D. Paris: Masson et Cie. 1920. (Med. 8vo, pp. vii+375; 8 figures. Fr. 20.)

⁷ *The Art of Attaining High Health, together with Aristology or the Art of Dining.* By T. Walker, M.A. London: P. Allan and Co. 1921. (Fcap. 8vo, pp. 283. 5s. net.)

THE COMING OF AGE OF ORAL SEPSIS.

BY

WILLIAM HUNTER, C.B., M.D., F.R.C.P.

SENIOR PHYSICIAN TO THE LONDON FEVER HOSPITAL; CONSULTING
PHYSICIAN TO CHARING CROSS HOSPITAL.

ON the occasion of which an account appeared in the JOURNAL of May 28th, p. 787, Sir Thomas Barlow kindly mentioned my earlier studies on anaemia (1887-90) and the endeavours underlying them to ascertain causes rather than find remedies. May I refer to the following, which I recall now with interest? When, after five years, I described the results (in 1890), I received a letter from a friend saying that it was all very well to describe results of observations and experiments, but what was the practical good of them? The reply I made was: "I don't know what the practical good is, but these are the facts."

The sequel, ten years later (1900), was the practical one, whose importance is now so widely recognized, to which reference was made by Sir Thomas Barlow—namely, the recognition of "Oral Sepsis" as the greatest septic infection in medicine, and of "Oral Antisepsis" as one of the most important and simplest and easiest measures for the prevention of a widespread group of maladies affecting almost every system of the body.

So far as this great practical measure is concerned, it was infinite curiosity about a piece of pigment of no earthly interest to anyone—followed up by studies and experiments lasting fifteen years—that led me to attach importance to oral sepsis as a disease factor, now recognized to be of the greatest possible practical interest to everyone. This outcome has been the greatest satisfaction of my life.

It is of the more interest to me since, as it happens, this summer "Oral Sepsis" celebrates her coming of age—the 21st anniversary of her appearance in medical literature under her new name. She made her entry very quietly, shyly, and even apologetically, her sponsor introducing her with these words:*

"That the common condition I am now about to describe should have any possible connexion with anaemia, especially with so severe and rare a form of anaemia as the one which (alone among all diseases) bears the deadly prognostic title of 'pernicious,' was something for which I was quite unprepared. But the following are the facts."

Although of good parentage—her parents being Experimental Pathology and Clinical Medicine—she had been and still remained at the age of eleven a very delicate child. To give her courage and individuality I sought for a fitting name, and gave her the name of "Oral Sepsis" ("Oral Sepsis as a Cause of Disease," BRITISH MEDICAL JOURNAL, July 28th, 1900, p. 215). My object in giving this special name was definitely to emphasize the nature and importance of the part she played in connexion with ill health.

"It is not the absence of teeth, but the presence of sepsis; it is not dental defects *per se*, but chronic septic poisoning; it is not defective mastication but effective sepsis; it is not accumulation of fermenting food debris between the teeth, but the presence of virulent streptococcal sepsis in open wounds in the gums and sockets, in the teeth and bone, that underlie the ill health so frequently associated with 'bad mouths.'"

The first reception she got was chilling enough. She was promptly called names—designated a "hypothesis" and a "theory"; even the play in which she was staged—that of "Medical Sepsis," as I termed it in 1904—was said not to exist. I recall, on the other hand, the encouraging note I received from an old friend and good physician, the late Dr. George Gibson of Edinburgh: "You have not only invented a new name, but a new disease." Soon, from 1902 onwards, the interest in oral sepsis grew steadily greater, and it has increased steadily ever since.

If the great subject of sepsis in medicine was a theory so also was the whole subject of surgical sepsis; if oral sepsis was a theory, so also was a fatty tumour. The only difference between the two was that no one knew anything about a fatty tumour except that it was a fact which could not be explained, was not preventable, and did no harm; whereas oral sepsis and the multiple ill effects which it produces were great facts of the first magnitude, which could be explained, and were largely preventable.

Since that time much about "oral sepsis" has appeared in medical literature, and an incalculable amount of oral sepsis has been removed, with incalculable benefit to the

world. But an incalculable amount still remains. It still holds true, as summarized in the presidential address (July, 1910) of a physician than whom no one has wider knowledge and experience—Dr. J. Mitchell Bruce:

"Its effects are so widespread, so multiple, and frequently so grave as to make us ashamed of our previous blindness to a common source of blood infection staring us in the face all these years."

But if oral sepsis as a disease factor has thus played, and still continues to play, so important a part, we have now the satisfaction that it is playing it before a big audience; and that many "antibodies" have been formed against it in every branch of medicine, representing almost every system of the body.

To sum up: the gorge created in the landscape of medical diseases by this subject of oral sepsis in the past twenty-one years is both wide and deep; the volume of muddy waters of medical sepsis which has all along been there can now be seen crashing down it visible to all eyes. The rôle of oral sepsis in its causation has received a great volume of recognition, obscured at first by the mists created by its fall, then collecting itself into a great body of facts, till in a period of ten years (1910), and still more now after twenty-one years, it can be seen pouring itself over the "rapids" in a torrent of recognition of its importance not only as a medical but as a great national concern of health.

May I add that I have watched this result with great interest, both from a clinical and a pathological point of view? From the clinical point of view, in the course of some forty years' experience, I can recall nothing so astounding as the marvellous change in health I have seen time and again caused by the removal of obvious, glaring, but continuously overlooked conditions of oral sepsis.

But great as this interest has been, it has almost, if that were possible, been exceeded by the reflection, that so far as my own experience is concerned, it was pathology, and first of all experimental pathology, that formed the basis of my original conclusions. For it was the establishment of the first research endowment in experimental pathology in the country—namely, the John Lucas Walker Studentship in the University of Cambridge—that first gave me in 1887 the opportunity to begin the studies, remote apparently from all spheres of practical interest, that have been associated, directly or indirectly, with such extraordinarily interesting, practical, and unexpected results in the arrest and prevention of disease. So far as these studies have been connected with any of these results, credit may most fittingly be given to the far-sighted and beneficent purposes of those who, like the founder of that Studentship, endeavour to advance the healing art by facilitating investigations into its causation that might otherwise have been impossible.

THE SERUM DIAGNOSIS OF SYPHILIS.

PROFESSOR DREYER'S METHOD.

ON June 2nd Professor GEORGES DREYER, M.D., F.R.S., introduced by Sir ALBROTH WRIGHT, gave a lecture, in the Institute of Pathology and Research at St. Mary's Hospital, on the flocculation test for syphilis, which he has devised.

Professor DREYER began by pointing out that the Wassermann reaction, although for all practical purposes specific, was not really quantitative, so that different workers' results could not be compared numerically, and moreover it was very complicated and employed a large number of variable reagents. In attempting to do away with the necessity for the haemolytic system Heman and Perutz had used the property possessed by syphilitic serum of flocculating a saline suspension of sodium glycocholate and cholesterin. This reaction, however, had proved less sensitive than the Wassermann reaction, and also gave a fair number of false positive results. Sachs and Georgi had improved the flocculation test by using an alcoholic heart extract with cholesterin. To 0.5 c.c.m. of this fluid they added 1 c.c.m. of the serum to be tested diluted 1 in 10, incubated the tubes for two hours at 37 °C. and then left them at room temperature for twenty hours before reading the results. This test also gave in the hands of most workers a certain number of false negative and false positive results.

Professor Dreyer then outlined the ideals to be aimed at in devising a test of this sort. These were: that the technique should be simple; that there should be one

* "Pernicious Anaemia," *Lancet*, January, 1900.

variant only—namely, the serum to be tested; that the results should be expressible in definite units per cubic centimetre, whether absolute quantities (for example, cubic centimetres) or relative quantities (for example, drops) of the different reagents were used in the test; and finally, that the standard unit should be easily maintained and checked.

The Flocculation Test.

The lecturer then detailed the reagents and apparatus required for his test. These were as follows:

An alcoholic extract of calf's heart prepared in a definite and simple manner, which he described. This solution keeps perfectly for at least two years, at room temperature, in the dark.

A 1 per cent. solution of pure cholesterol in absolute alcohol.

The serum to be tested. Sterile 0.9 per cent. saline.

Agglutination tubes and stands.

Pipettes and water-baths.

An apparatus, consisting of a floating siphon, for delivering drops of saline at a definite rate.

A shaded electric light and a 6 magnification hand lens.

An essential feature of the test is the method of preparing the saline suspension of the heart-extract-cholesterol mixture, so that it is the same on all occasions and when made by different workers.

Five c.cm. of the heart extract and 0.25 c.cm. of the cholesterol solution are measured into a clean dry tube and mixed; 1 c.cm. of this mixture is placed at the bottom of a 100 c.cm. measuring cylinder. Sterile normal saline is then allowed to fall from the dropping apparatus a distance of 36 cm. on to the surface of the liquid in the cylinder at such a rate that 34 c.cm. are delivered in 4 mins. 30 secs.

Two suspensions are prepared in this manner, namely:

a. One c.cm. of the heart-cholesterol mixture into which are dropped 10.7 c.cm. of saline.

β. One c.cm. of the heart-cholesterol mixture into which are dropped 34 c.cm. of saline.

The test is then set up, using the two suspensions α and β and different dilutions of serum as shown in the following table.

No. of Tube.	Drops of Saline Solution.	Drops of Serum Diluted 1 : 1. 1 : 20.	Drops of Suspension.	Total Dilution in which the Serum Acts.
1	0	20 1 : 1	6 α suspension	1 : 1.25
2	0	10 1 : 1	15 β suspension	1 : 2.5
3	5	5 1 : 1	15 "	1 : 5.2
4	8	2 1 : 1	15 "	1 : 13.1
5	9	1 1 : 1	15 "	1 : 26.4
6	0	10 1 : 20	15 "	1 : 46
7	5	5 1 : 20	15 "	1 : 92
8	8	2 1 : 20	15 "	1 : 232
9	9	1 1 : 20	15 "	1 : 462

The dilutions in the last column are calculated with allowance for the difference in size of the drops of the three reagents. After the test is set up the tubes are incubated for seven hours in a water-bath at 37° C. The results must be read by artificial light—for example, an electric bulb with an opaque shade so arranged that the light falls on the tubes but not on the observer's eye.

The lecturer then described the different degrees of flocculation observable—namely, Total (t.), Standard (s.), Trace (tr.), and Nil (0) with their intermediate degrees.

"Standard" flocculation can readily be seen with the naked eye; the fine flocculi are evenly distributed, of uniform size and definitely separated from one another. "Trace" is the term applied to very fine flocculation not certainly visible to the normal eye, but readily seen with the 6× hand lens.

The result is expressed in what Professor Dreyer has called Sigma (Σ) units. The standard Σ unit is an arbitrary unit arrived at as follows: The amount of serum which when made up to 1 c.cm. with normal saline causes "standard" flocculation on being mixed with 1.5 c.cm. of a particular β suspension and kept at 37° C. for seven hours is said to contain four Σ units. To find the strength of a serum in Σ units one must multiply the dilution in which "standard" flocculation occurs by the suspension factor of the particular suspension.

Professor Dreyer then showed tables by reference to which the strength of a serum in Σ units could be computed when the "suspension factor" of the particular

suspension in use was known. He mentioned the following precautions which must be observed:

A negative result in a contaminated serum could be trusted. A positive result in an contaminated serum could not be accepted, and the test must be repeated with another specimen. No antiseptics were permissible in any of the reagents.

Hæmolysis of the blood to be tested, if due to mechanical shaking in transit, did not matter; if due to alcohol or ether in the syringe with which the blood was collected it upset the reaction, though to a less extent than the Wassermann reaction.

All vessels must be scrupulously clean.

The incubation period must not exceed seven hours, owing to increased danger of false positives from contamination of the serums. Water in the water-bath should not reach more than 1/2 or 2/3 the height of the liquid in the tubes. If it stood higher convection currents in the tubes were less effective, and the results were not clean cut.

Results were to be interpreted as follows. In cases with no definite history of syphilis—

Less than 1 Σ unit, negative.

Four units and over, positive. If between 1 and 4 units, test should be repeated in case mild degree of contamination of the serum had been overlooked. If result again between 1 and 4 units, positive.

In cases with a definite history of syphilis—

Less than one unit, negative; more than 1 unit, positive.

Cerebro-spinal fluid, whatever the history, less than 1 unit, negative; more than 1 unit, positive.

Professor Dreyer then gave the following results of his test in comparison with the Wassermann reaction:

Cases.	Wassermann Reaction.	Σ Reaction.	
686	Negative	Negative	} Definite history or evidence of syphilis.
322	Positive	Positive	
59	Negative	Positive	
5	Positive	Negative	
4	Positive	Negative	
1	Negative	Positive	} No definite history or evidence of syphilis.

Theory of the Wassermann and Σ Reactions.

The lecturer then went into the theory of the Wassermann and Σ reactions. He came to the conclusion that there were probably two substances involved in the Wassermann reaction—a thermolabile present in all serums, and a thermostable present only in syphilitic serums. The destruction of the thermolabile substance accounted for the weakening of the Wassermann reaction often witnessed after heating the serum.

He thought that most probably the thermostable substance caused the flocculation in the Σ and Sachs-Georgi reactions, and that the thermolabile substance was responsible for the inhibition of flocculation sometimes seen in the higher concentrations, without, however, in his reaction, affecting the end titre of the serum. It was probably the occurrence of inhibition which spoils the Sachs-Georgi reaction.

Professor Dreyer ended with the following conclusions:

1. That the reaction described had yielded results which compared favourably with those given by the Wassermann reaction.

2. That the results are quantitative as well as qualitative.

3. That the reaction can be standardized and different workers' results directly compared.

4. That the effect of treatment in a case of syphilis can be followed in a change in the unit content of the serum.

5. That consequently different methods of treatment can perhaps be compared by their effect on the Σ reaction.

ACCORDING to the New York Medical Record, telephone exchanges for physicians have been installed at Des Moines, St. Louis, and St. Josephs, while Sioux City is shortly to have a similar system. The service is described as follows: When an emergency arises and the person wishes to locate his family doctor who is a member of the exchange either at his consulting room or his residence, by referring to the telephone book he finds the note "If no answer call No. —," and the exchange immediately gets in touch with the doctor wanted either by telephone or messenger.

VENEREAL DISEASES.

THE POLICY OF THE GOVERNMENT.

THE following communication, dated June 2nd, 1921, has been received from the Ministry of Health:

A circular dealing with the prevention and treatment of venereal diseases has been sent to all county and county borough authorities in England and Wales. The general conclusion of the Interdepartmental Committee which considered the question in the light of the experience gained during the war was that although certain drugs, properly and skilfully applied, may be efficacious in preventing venereal disease, the most carefully organized system for the supply of these drugs in "packets," and the instruction of soldiers as to their use, did not produce such a general reduction in the incidence of the disease as to warrant their recommendation for general use by the civilian population. It was, moreover, found that where preventive treatment by a skilled attendant was provided, after exposure to the risk of infection, the results were better than when the same measures were taken by the individual concerned, even though he had received the most careful instruction.

Official Advice.

The Government have given careful consideration to the views of the official Interdepartmental Committee, and the unofficial subcommittee of the National Birth-Rate Commission recently published, and find that there is general agreement that the best way to avoid risk of venereal disease is to abstain from promiscuous sexual intercourse, and that disinfection immediately after exposure to risk of infection is effective only to the extent to which it can be thoroughly applied in the particular case. They find that medical opinion is divided as to the practicability and likelihood of the success of self-disinfection by the civil population, whereas on the moral and social side most weighty objections have been advanced against it. In the circumstances the Government have decided that, whatever the individual or groups of individuals may practise or recommend, they cannot make a system of self-disinfection for the civil community part of their official policy.

On the other hand, the Government have decided to suggest the advisability of local authorities undertaking public instruction and enlightenment as to the dangers arising from promiscuous sexual intercourse and the disastrous consequences on the general health of the community which result from the spread of these diseases. They say: (1) These diseases are usually contracted through promiscuous sexual intercourse, and the best way to avoid risk is to avoid such intercourse. It is the duty of all individuals who have incurred, or think they have incurred, the risk of contracting disease to cleanse themselves thoroughly and immediately, and thereby diminish the risk. (2) If any signs or symptoms of disease, however slight, are experienced, the individual should promptly seek medical advice or attend a venereal diseases clinic; for any attempt at self-treatment of these diseases is likely to be disastrous.

The circular also clears up one or two doubtful points as to the continuance of experimental ablation centres, and as to the legal position of a chemist selling disinfectants against venereal diseases so long as the substances are not sold accompanied by any printed or written recommendations as to their use. It is hoped that this clear statement on behalf of the Government may form a useful basis for united co-operation of persons and societies concerned in the campaign against venereal diseases.

The Circular (No. 202) issued by the Ministry of Health is dated May 31st, 1921, and signed by Sir W. A. Robinson, Secretary. It runs as follows:

Prevention and Treatment of Venereal Diseases.

1. I am directed by the Minister of Health to state that the Government have had under consideration the policy hitherto adopted in this country for dealing with venereal diseases, and the question whether any modification of that policy is required at the present time.

2. As the Council are aware, the national scheme for the prevention and treatment of these diseases is based upon the recommendations contained in the final report of the Royal Commission on Venereal Diseases. The main recommendations of the Commission were—

- (1) That gratuitous treatment for persons suffering from these diseases should be provided at hospitals and other institutions in all parts of the country.
- (2) That a widespread campaign of publicity and education as to the dangers and effects of these diseases, and as to the necessity for early and skilled treatment, should be undertaken.

These recommendations have been and are being carried out under schemes formulated by the Councils and approved by the Minister of Health or his predecessors, while the propaganda campaign, in accordance with the recommendation of the Royal Commission, has been directed, centrally by the National Council for Combating Venereal Diseases, under the supervision of this Department, and locally by the county and county borough councils, a large number of which have co-operated with the local branches of the National Council in carrying out measures of publicity and education. In a few areas, also, Ablution or Disinfecting Centres have recently been instituted as an experimental measure in order that facilities may be provided for the disinfection, by skilled attendants acting under medical supervision, of persons who have exposed themselves to the risk of infection with these diseases.

3. The experience gained during the war by different armies in attempting to prevent the spread of venereal diseases has given rise to question whether, in the case of the civilian community, some further measures should not be adopted with a view to diminishing the incidence of these diseases, and after the conclusion of hostilities this question was considered by an Interdepartmental Committee appointed by the Minister of Health. This Committee came to the general conclusion that although certain drugs, if properly and skilfully applied, are efficacious in preventing venereal diseases, the most carefully organized system for the supply of these drugs in "packets" and the instruction of men as to their use, did not produce such a general reduction in the incidence of these diseases as to warrant its recommendation by the Government. It was, however, found that where preventive treatment was provided, after exposure to the risk of infection, by a skilled attendant, the results were better than when the same measures were taken by the individual affected, even after the most careful instruction. Unofficially also this question has recently been under consideration by a Special Committee of the National Birth-Rate Commission, and the conclusions of that Committee are contained in a report which has now been published.

4. The Government have given careful consideration to the question on which the views of these two committees, official and unofficial, are not completely in accord—namely, the question of self-disinfection—but they find that there is general agreement on the following conclusions:

- (i) That the best way to avoid risk of venereal disease is to abstain from promiscuous sexual intercourse, and that a steady and continuous policy of public enlightenment on this point, and as to the risks of venereal disease and its resulting consequences on the general health of the community, is essential.
- (ii) That disinfection immediately after exposure to risk of infection is effective only to the extent to which it can be thoroughly and intelligently applied in the particular case.

They also find that medical opinion is divided on the question of the efficacy of self-disinfection for the civilian population, and in particular on such questions as (1) whether it is practicable to give such instruction to the population generally as will ensure that the disinfectants are thoroughly and skilfully applied; (2) whether the spreading of knowledge as to the efficacy of disinfectants would not lead to persons running the risk of infection who would otherwise avoid that risk, and thus increase the spread of disease; and (3) whether the disinfectants will not be used in some cases for the treatment of developed disease, with the result that proper treatment will be delayed and the cure of the disease rendered more difficult and uncertain.

5. The actual situation which confronts the Government is that there is not unanimity of opinion on the medical side as to the practicability and likelihood of success of self-disinfection for the civil population, whereas on the moral and social side most weighty objections are advanced against it. It is clear that this question is one which cannot be decided solely by reference to medical opinion—moral and social considerations of very great importance are involved in it. In the circumstances the Government have decided that they cannot give official support to self-disinfection as a policy.

6. The decision of the Government emphasizes the importance, in the interests not only of the individuals concerned, but also in those of the community in general, of continuing and extending public instruction and enlightenment as to the dangers arising from promiscuous sexual intercourse, and the disastrous consequences on the general health of the community which result from the spread of venereal diseases. The Minister is aware that in most parts of the country a wisely directed campaign has been, and is being, carried on in this direction, and he is advised that it is essential that no opportunity should be lost of educating public opinion on this matter. It is important that the Council should call to their aid every

available agency in their area which exists for the purpose of the moral and social betterment of the people, and the assistance of voluntary organizations of this kind should be most valuable in advising as to the lines on which a campaign of publicity and education can best be directed and as to the contents of such leaflets, posters, etc., as the Council may issue.

It is essential that due economy should be exercised in this matter as in all other public services at the present time, but the Minister trusts that the Council will not curtail their expenditure during the current financial year on educational and propaganda work in connexion with these diseases, and he is prepared, as indicated in paragraph (6) of Circular 192, to consider applications for his approval of limited expenditure for this purpose in excess of that incurred by the Council during the past financial year. This is a matter also in which the Council would be justified in looking to voluntary bodies for some financial assistance.

7. The question of the contents of any publications which may be issued by the Council on this subject is one for the decision, in the first instance, of the Council, but the Minister desires to suggest the advisability of the widespread issue of leaflets, etc., warning the public of the dangers of venereal diseases and containing advice on the following lines:

(1) The prevalence of venereal diseases is a grave source of danger and ill health to the public.

(2) These diseases are usually contracted through promiscuous sexual intercourse, and the best way to avoid risk is to avoid such intercourse. It is the duty of all individuals who have incurred, or think they have incurred, the risk of contracting disease, to cleanse themselves thoroughly and immediately, and thereby diminish the risk.

(3) If any signs or symptoms of disease, however slight, are experienced the individual should promptly seek medical advice or attend a Venereal Diseases Clinic.

(4) Any attempt at self-treatment of these diseases is likely to be disastrous.

8. The Minister is of opinion that the arguments which have influenced H.M. Government in deciding against any official advocacy of self-disinfection do not apply to the provision of Ablution Centres where facilities are provided, with proper safeguards, for disinfection by skilled attendants acting under medical supervision.

The experience so far obtained is not sufficient to enable any final conclusions to be drawn as to whether such Ablution Centres should be established permanently in large towns; but the evidence available as to the results obtained in different armies from the provision of these centres justifies further experiments of the same kind for the civilian population, and the Minister is accordingly prepared to consider applications for his approval of the experimental provision of further Ablution Centres.

9. It is understood that questions have arisen as to the precise effect of section 2 (2) of the Venereal Disease Act, 1917, and the Minister considers it desirable to state that, although he is not empowered to give an authoritative interpretation of the provisions of any Act of Parliament, he is advised that a chemist does not commit an offence by selling any substances for which he is asked, merely because those substances are capable of being used as disinfectants against venereal diseases, so long as the substances are not sold accompanied by any written or printed recommendations or instructions as to use. It should be carefully borne in mind that by sections 1 and 2 (1) of the same Act, an offence is committed by any person (other than a duly qualified medical practitioner) who for reward direct or indirect, treats, prescribes for, or offers advice in connexion with the treatment of venereal disease, and by any person who does any of these things or even offers to do them, by advertisement, public notice, or announcement.

SOCIETY FOR THE PREVENTION OF VENEREAL DISEASE.

THE annual general meeting of the Society for the Prevention of Venereal Disease was held at the house of the Royal Society of Medicine on June 6th, under the presidency of Lord WILLOUGHBY DE BROKE. The report of the year's work, read by Dr. WANSEY BAYLY, the Secretary, recorded that the society's efforts had been concentrated upon organizing that mass of public opinion which it believed to support its policy. These efforts had taken the form of press propaganda, addresses to trade union and other organizations, debates and conferences, and the circularization of members of public bodies. The number of county and borough councils which had adopted the society's policy had increased from twelve to twenty. A branch had been formed in New Zealand, one was projected in South Africa, and propaganda was proceeding in Canada and in Jamaica. The report of the Birth-Rate Commission in its medical aspects was claimed as an endorsement of the society's policy. The treasurer's report revealed a total income for the year of £922, and an expenditure of £878.

Lord WILLOUGHBY DE BROKE said that venereal infection still constituted a grave danger to the public welfare, in spite of the official policy, which consisted

of exhortations to be chaste, warnings against the danger of unchastity, and advice to the incontinent to go to the doctor on becoming infected. All these were essential in dealing with the problem, but they were demonstrably insufficient. Two further lines of action were possible: one consisted of disciplinary methods, such as compulsory notification and detention, but these measures were highly contentious, and in any case would involve legislation and consequent delay. The other line of action was the provision of means of immediate self-disinfection, and this was the society's policy. Recently the Ministry of Health had issued a circular to the county and borough councils in which it was stated—

"It is the duty of all individuals who have incurred or think they have incurred the risk of contracting disease to cleanse themselves thoroughly and immediately, and thereby diminish the risk."

That, with the substitution of the word "disinfect" for "cleanse," might have been written from the offices of the society. The society had endeavoured to persuade the Ministry of Health to alter the Act of 1917 by allowing chemists to sell recommended disinfectants under the Government's imprimatur, but the Minister had stated that there were moral and social considerations to be taken into account before self-disinfection could be embraced as a policy. In face of the admission he had just quoted the society should now approach the Ministry with a view to removing the disability of chemists, and should assert itself as the proper body to take the risk and responsibility of issuing instructions and recommending disinfectants. He moved:

That the Society for the Prevention of Venereal Disease take immediate steps to apply formally to the Ministry of Health for their sanction, under the Venereal Disease Act, 1917, of the preparation and sale by chemists, under the supervision and control of the Society for the Prevention of Venereal Disease, of the materials for immediate self-disinfection recommended by them.

Lady ASKWITH seconded the resolution, and it was carried unanimously.

Sir FREDERICK MOTT supported the society's policy, because he believed it to be the only one which could effectively combat the disease. Human nature was not going to be changed at once by moral persuasion, especially having regard to the psychological disharmony prevailing at present in social life. It was said on the Birth-Rate Commission, by those who supported the policy of the National Council, that self-disinfection in the army had not produced the happy results expected. But any method of self-disinfection must be efficiently carried out, with strict observance of the regulations and instructions. When disinfection was carried out under proper conditions—as Sir Archdall Reid had shown at Portsmouth—the success was phenomenal. The early ablation centres of the Government were not materializing. One was in existence (at Manchester) and five were in prospect, but there were 183 curative treatment centres, and therefore there should be 183 areas in which prophylaxis was necessary. Nor would these centres be likely to multiply, because the ratepayers objected to this burden. The society's policy of immediate self-disinfection was therefore called for, and in order that it might be efficient there must be the means of obtaining the disinfectants, and the proper instructions for their use, without trouble.

Dr. J. H. SEQUEIRA said that the upholders of the official policy appeared to rejoice in the increased numbers attending the clinics, whereas a matter for congratulation would rather be diminished numbers at the clinics and a larger proportion of those who had been foolish enough to risk contagion seeking the means of self-disinfection.

Other speakers were Lieut.-General Sir FRANCIS LLOYD, who commented on the unwillingness of public bodies to face the situation; Miss NORAH MARCH, who described propaganda among women's organizations; Rev. HUGH CHAPMAN, the only clergyman as yet officially connected with the society; and Miss ETTIE ROUT, who gave reasons for the failure of self-disinfection in the Rhine army. These reasons were chiefly that the prophylactic system in its direction from London was weak and timid and the outfit out-of-date; there was great laxity and half-heartedness among many of the field officers; officers who permitted a high rate of infection to arise or continue in their ranks were not demobilized, and soldiers who contracted the disease were not punished sufficiently to deter them or to make them particularly anxious for self-disinfection.

The officers and members of the Executive Committee of the society were re-elected.

British Medical Journal.

SATURDAY, JUNE 11TH, 1921.

A NEW STUDY OF APHASIA.

I.

DR. HENRY HEAD in his Hughlings Jackson Lecture for 1920¹ reviewed the subject of aphasia from the historical standpoint. His Linaere Lecture² had dealt with the clinical aspects of disorders of speech. The two lectures are inseparable, and in order to appreciate the importance of Dr. Head's suggestions, the Hughlings Jackson Lecture claims our first consideration.

In the past many hypotheses as to the cerebral localization of speech have been accepted which were neither provable nor useful. In the Middle Ages the brain was supposed to contain three ventricles, of which the anterior was the seat of sensation, the middle that of cogitation and reasoning, whilst the posterior was assigned to memory. Descartes and the philosophers of the seventeenth and eighteenth centuries swept away the materialism of the schoolmen, with the result that no one presumed to correlate directly the activities of the mind with the life of the brain. Gall was the first to insist that the intellectual processes of the mind were materially bound up with the integrity of the brain. His attempts to localize mental functions and moral faculties in the brain were based on the observed effects of injuries; and, although his conclusions may have been fantastic, there was sense in his plea for examination of the brain from the spinal cord upwards. In 1861 Broca described a definite clinical condition which he called "aphemia," produced by destruction of brain substance, and he believed that he had found the faculty of articulated language in the third frontal convolution. Interest in the question of the localization of speech rapidly spread to England, and in 1864 Hughlings Jackson published his first paper on "Loss of speech, with hemiplegia of the left side." Broca and Jackson took part in a discussion on aphasia at the British Association in 1868, so that their views can be readily compared.

The clinical observations of Broca were clear and precise. He recognized two main groups of speechless patients. First, the "aphemic," who has a reduced vocabulary and may be speechless except for a few monosyllables which do not seem to belong to any language. Yet his ideas appear to be intact, he can understand what is said to him, and he recognizes words and phrases which he cannot repeat. The "amnesic" patient, on the other hand, can pronounce words, but they have no bearing on the ideas he wishes to express. He has not lost all kinds of memory, but he no longer recognizes the conventional association between ideas and words either spoken or written. Up to this point Dr. Head admits that Broca's statements are consistent with fact. But the larger number of cases do not correspond with these two clean-cut divisions, and this hampered the determination of the localization of the lesion. Broca himself insisted that it is aphemia only which is caused by a lesion of the third frontal convolution.

Hughlings Jackson, on the other hand, contemplated a bolder and wider conception of speech and its disorders. He failed to command the attention of the medical world, either at that time or later, because he declined artificially to simplify problems which he realized to be intricate and immensely difficult. Jackson did not shrink from approaching the subject from the psychological as well as from the anatomical side, and psychology was in those days considered utterly remote from clinical medicine. He pointed out that healthy language consisted of two distinct but usually inseparable forms: (1) Intellectual—that is, the power to convey propositions; (2) emotional—the ability to exhibit states of feeling. These two are separated by disease. In most cases it is intellectual language which suffers; emotional language usually escapes. The power to form propositions is affected, and not the memory of words or faculty of language. The higher the propositional value of the task the patient is asked to carry out the less he will be able to respond, whereas the lower or more automatic the task the easier will it be to perform. This is the basis of Hughlings Jackson's treatment of disorders of speech.

The temptation to appear simple even at the expense of accuracy was, however, too great for Jackson's contemporaries. They were fascinated by diagrams which could be memorized without necessarily understanding the problem involved. Bastian, Baginsky, Wernicke, and Liehtheim headed a veritable school of "diagrammatists," who, as Head says, "were compelled to lop and twist the clinical facts to fit the Procrustean bed of their hypothetical conceptions." Nevertheless they held the field almost unchallenged until, in 1905, Pierre Marie startled the medical world by a pronouncement which Mott described as "an earthquake to our cherished beliefs in cerebral localization." Marie asserted that the third frontal convolution does not play any special part in the function of language, and that "sensory" aphasia could no longer be accepted. Marie's views led to heated discussions on such terms as "Broca's aphasia," "total aphasia," "word-blindness," and "word-deafness," which, Head remarks, are pure phrases not corresponding to any clinical phenomena. Marie claimed that Broca's aphasia was always accompanied by a marked diminution in the general intelligence, that it was not a special loss of word memories, but a defect partly of general intelligence and partly of special intelligence of language. Jackson had appreciated this long before and had gone much further towards analysing the intellectual defects involved. But his writings were forgotten or remained unread. They bristled with difficulties, and lacked the fluent dogmatism of his contemporaries.

The summary of Hughlings Jackson's views given by Dr. Head may be condensed as follows:—(1) Aphasic patients may be divided into two groups: in Class A the patient is almost speechless, though he may utter one or two unvarying words or jargon; Class B comprises those who have plentiful words but habitually use them wrongly. (2) Loss of power to carry out an order depends on the complexity of the task; the more abstract the conception, the more difficult its execution. (3) Higher and more voluntary aspects of speech suffer more than lower and automatic; hence emotional and impulsive utterances may be retained. (4) Writing is affected not as a separate "faculty," but as part of the failure to propositionize in words. (5) Defects in reading are not due to some loss of function called "alexia," but to an inability to reproduce a proposition which may none the less be received accurately. (6) Imperception,

¹ *Brain*, vol. xliii, p. 390.

² *Ibid.*, Part 2, vol. xliii, p. 87. See also Head, "Disorders of Symbolic Thinking and Expression," *British Journal of Psychology* (General Section), vol. xi, Part 2, p. 179.

is on the receptive side what "aphasia" is on the emissive. Defects of speech are caused on the emissive side by inability to form or express a proposition in words; on the receptive by failure of those mental processes which underlie perceptual recognition. (7) External and internal speech are identical, except that the former is exhibited in the utterance of articulated words, whilst the latter can be discovered by writing only. (8) External and internal speech depend upon the formulation of a proposition which can be verbalized in speech or writing. If the patient cannot formulate to himself and retain a sequence of abstract propositions, the emissive aspect of speech will be affected. (9) If to this defect is added "im-perception," the patient will show impaired comprehension as well as impaired speech. (10) In the majority of cases with defects of speech mental images are unaffected, notwithstanding that almost every hypothesis propounded in the last forty years presupposes some defect in auditory or visual word images.

Thus it is evident that the teaching of Head no less than that of Hughlings Jackson brings us back for our starting point to Locke's view of language—namely, the use of articulate sounds as marks or signs of ideas within a man's own mind whereby they may be made known to others and the thoughts of men's minds be conveyed from one to another. We propose to indicate some of the consequences of this doctrine in another article.

THE AMERICAN UNIVERSITY.

AFTER the London Conference of all the Universities of the Empire in 1919 the Administrative Committee of the Australian universities felt that an era of greatly extended and improved relationship between the universities of the world had begun, and that, if Australia were to keep its place among them, more must be known of the highly important American group. Accordingly, the chairman of the Administrative Committee spent three months in America, and, without any idea of publication, wrote a report designed to furnish the Australian universities with answers to certain questions concerning the American universities. At the wish of the University of Sydney, Professor E. R. Holme has now published part of this attractively written report,¹ which he modestly describes as a preliminary survey of a very wide field, and as but the first impression of a very large subject. Some account of what he has to say will, we believe, be of interest to many readers in this country.

The typical American university is in a period of transition to an improved method of government and administration. The numbers of students have increased since the war, though (probably from the protection exercised by restriction of entry) there is no parallel to the fourfold increase of students reported at Liverpool. A fundamental difference between the American universities and those at Oxford, Cambridge, in Scotland and in Australia is that the former continue to be responsible for a very great amount of secondary education, such as is carried out by our public schools; the reason for this is that the period of four years of American high school education, intended to cover the pupil's school time from his 14th to his 18th year, is not long enough; and one result is that a well-trained American student graduates in medicine two years

later than a well-trained European. The American school system, copied from Prussia, is not one for imitation in Australia, which directly inherited the British scheme—one regarded as providing a good sound basis for development. The matriculation requirements naturally vary among the different universities, but entrance by leaving certificate or high school graduation diploma is one of the essentials. If the university could enforce a proper entrance standard in appropriate subjects, much benefit would accrue to secondary education: there appears, however, to be considerable risk that the influence may work in the opposite direction and that the university entrance standard may be pulled down to the low average level of high school training in schools that have little need to prepare students for universities. There is indeed too much competition for students among American universities, and this naturally exerts an influence adverse to the maintenance of matriculation standards. Nevertheless it is remarkable how good both in quality and quantity is the work accomplished by the American university upon the insufficient and unsafe basis of American public secondary education: it trains its undergraduates to be university men and women all their lives, and by means of associations of alumni (fraternities) and alumnae (sororities) and of publications keeps them mindful of the obligations of academic citizenship. This "class" system—a characteristic American tradition—keeps fellow students permanently in touch, and there is no doubt about the vast and beneficent influence exerted by the universities on American society.

American universities have suffered from the example set by modern competitive methods in business; for a university is not a mercantile venture, and the autocratic powers vested in the president of a university, to whom there is no corresponding official in British universities, undoubtedly has potentialities for harm. There is also, perhaps, too much administrative machinery in American universities, and the attraction of able men out of professorships into administrative posts by apparently higher positions and actually better emoluments is a bad policy. Out of 150 institutions styling themselves universities forty are State universities, and being therefore more generously supported are thus able to supply the deficit not met by the students' fees. The future of the American university should be predominantly on these lines, for, though they are more exposed than endowed universities, such as Harvard, Yale, Princeton, and the Johns Hopkins, to popular influence which might force them to derogate from the higher ideals of a university, it does not appear to be a sound criticism that they are more utilitarian in their motives, for all universities are much concerned with utilitarian purposes, and through the ages have given professional training—for example, in medicine. But the State universities obviously cannot specialize in divinity, and are less impeded than the old endowed universities in making a speciality of the modern sciences and the mechanical arts. In accordance with the Land-Grant Acts, the first in 1862 being known as the Morrill Acts, Congress has allotted to State universities, and for their foundation in States without universities, grants of land. This federal aid to universities is under the general supervision of the Federal Bureau of Education, which is a section of the Department of the Interior. It is rather remarkable that there is not in the United States a university that is a federal institution, and therefore national in the specific sense, especially as George Washington urged the foundation of such a university and left a bequest for its endowment.

¹*The American University: An Australian View.* By E. R. Holme. Professor of English Literature in the University of Sydney. Sydney: Angus and Robertson, Ltd. 1920. (Cr. 8vo, pp. 242. 7s. 6d.)

The really typical American graduate university justly has a high reputation; thus Harvard is famous among all English-speaking peoples in law, and is rising as high in medicine, though in this respect the Johns Hopkins, with distinctions in many other subjects—of which some, such as political economy, are comparatively recent—is perhaps better known. The new development of the University of Minnesota in connexion with the Mayo foundation is rightly mentioned here. It appears that the separation of undergraduate from graduate work has now gone far enough in America. Professor Holme considers that the separate undergraduate university for women is one of the most valuable of the American contributions to higher education, and he refers to the voice recently raised in prayer in this country for at least one women's university and at least one for men only. In the interesting chapter on university extension, which has developed to such a remarkable degree in America, an account is given of the Chautauqua movement begun in 1874; tens of thousands make a kind of Canterbury pilgrimage to this lake-side summer resort, where a holiday may be combined with almost any form of study, and a degree obtained after three years, in each of which six weeks' work is done in Chautauqua classes, the intervening time affording opportunity for reading Chautauqua textbooks.

Though Professor Holme considers it impossible for Australia to copy the American university, which is totally un-British, and Australian universities must develop on the lines of British tradition as long as the Australian people remain a growth from the old stock—97 per cent. of which has the British Isles for its ancestral home—Australia may receive from America some precedents of obvious value, such as those of the "Dormitory," administration, federal aid, and graduate studies which are all critically examined.

THE BIRTHDAY HONOURS.

THE Birthday List contains some honours which will be received with more than ordinary satisfaction by the medical profession. In the first place it is to be noted that the honour of knighthood is conferred on two of the brightest illustrations of scientific medicine—Professor Arthur Keith and Dr. Thomas Lewis. Sir Arthur Keith has added lustre even to the post of Conservator of the Museum of the Royal College of Surgeons of England; he is equally at home in discussing the antiquity of man and in expounding the historical and comparative application of the abstruser truths of anatomy to every-day surgery, medicine, and anthropology. Sir Thomas Lewis is described in the list as honorary consulting physician since April, 1918, to the Ministry of Pensions; in that capacity and as Director of the Medical Research Council's Department of Clinical Research in the cardiographic department of University College Hospital Medical School he has formed one of the most interesting clinics in London, but before and since he has laid the profession in all countries under a deep debt of gratitude by reason of the originality and accuracy of his experimental observations on the mechanism of heart function, and the sanity and clarity of his application of these experimental researches to practical medicine. He is physician to University College Hospital and lecturer on cardiac pathology in its Medical School. His most important contribution to literature is the volume, the second edition of which appeared recently, on the *Mechanism and Graphic Registration of the Heart Beat*. Dr. Sydney Russell Wells, who also receives the honour of knighthood, has been Vice-Chancellor of the University of London since 1919; he, too, is known for his study of disorders of the heart. Dr. William

Henry Willcox, who receives the distinction of F.C.I.E., is physician at St. Mary's Hospital, and was known before the war as medical adviser to the Home Office. As consulting physician to the forces in Mesopotamia he was a colleague of the late Sir Victor Horsley, and afterwards as medical adviser rendered important services to the civil administration in Mesopotamia. We have had the opportunity of publishing an account of many of his observations in these capacities, and in particular those on the cause and prevention of scurvy and beri-beri, and on the nature, prevention, and treatment of heat hyperpyrexia, while his interest in general clinical subjects is shown by the paper published only last week on infective arthritis in its relation especially to infection of the teeth. Major-General Sir William Rice Edwards, who also receives the K.C.I.E., entered the Indian Medical Service in 1886 and became Director-General in 1918. Much of his early service was spent on the North-West Frontier. He was on Lord Roberts's staff in India in 1890 and again in South Africa in 1900, where he much distinguished himself and received the C.M.G. In 1913 he was appointed Inspector-General of Civil Hospitals, Bengal, and in the following year became C.B. His work as an administrator has been marked by a statesman-like grasp of the medical situation in India and an appreciation of the need of improved medical and post-graduate education and of extended opportunities for research. While in Bengal he gave his aid in the foundation of the Calcutta School of Tropical Medicine; since he became Director-General he has shown a like interest in the establishment of the Bombay School of Tropical Medicine and has directed the energies of the Indian Medical Research Fund into some new and fruitful fields. He has been a loyal friend of his own service, whose cause he has championed without fear or favour in troublous times; the success which has attended the efforts of the British Medical Association to remove some of the disadvantages under which the Indian Medical Service has laboured has been due in no small measure to his sympathy. Surgeon Rear Admiral P. W. Bassett-Smith, C.B., who is promoted to be K.C.B., rendered important services both before and during the war while attached to the Royal Naval Hospital at Haslar and to the Royal Naval Medical College at Greenwich. The honour of knighthood is conferred upon Dr. F. Conway Dwyer, surgeon to the Richmond Hospital, Dublin, inspector of anatomy in Ireland, and formerly president of the Royal College of Surgeons in Ireland. A like honour is received by Brigadier-General Donald Johnstone McGavin, C.M.G., Director-General of the New Zealand Army Medical Service. The distinction of C.B. is conferred on Colonel Charles Edward Pollock, C.B.E., assistant director of the Medical Service, Eastern Command. The honour of C.I.E. is received by Lieut.-Colonel Benjamin Hobbs Deare, I.M.S., Principal of the Medical College, Calcutta, and Dr. Mohendra Nath Banerjee, principal of the Carmichael Medical College, Belgatchia, Bengal. The Kaiser-i-Hind medal is awarded to the Rev. Ernest Muir, M.D., missionary and research worker in leprosy, Bengal.

WOMEN AT CAMBRIDGE.

On June 4th, by a narrow majority of 116 to 111, the Cambridge Senate approved a grace authorizing a vote to be taken on June 16th upon both of the alternative propositions for regulating the relation of women students with the University. Votes for both graces will be accepted at the same time. In the event of the first being carried, the second will be withdrawn, and the votes destroyed. The present position arises directly out of the rejection last December of Report A of the Syndicate appointed to consider the question.¹ That rejection, together with the obvious impracticability of giving effect to Report B in

¹ BRITISH MEDICAL JOURNAL, August 21st, 1920, p. 284, and December 18th, 1920, p. 955.

face of the opposition of the governing bodies of the Women's Colleges, left the matter in a position admittedly unsatisfactory. The first proposal is the result of an informal conference of both parties, convened by the Vice-Chancellor, and the 187 signatures to the memorial, in which the scheme was submitted in April, include the names of fifty members of the Senate who voted *non placet*, and twenty-two who did not vote on December 8th. There is this evidence for a substantial measure of agreement upon the compromise which it embodies. The chief points in the scheme are (1) that women students would be matriculated members of the University, and security of admission to university teaching would be obtained; (2) that all degrees would be open to women; (3) that women would be eligible to be members of Boards of Studies, and for Professorships, Lectureships, Examinerships, etc., as well as for Prizes and Studentships; (4) that two women Assessors would sit on the Council of the Senate, with a consultative voice but no vote; (5) that the number of resident undergraduate women would be limited to 500, or such larger number as the University may from time to time prescribe by grace; and (6) that the discipline of the women students would be in the hands of a Board of Women, with two men Assessors. The scheme, as outlined above, definitely excludes women from membership of the Senate, and so falls short of granting the full membership for which the women had hoped. The compromise is, however, acceptable to the governing bodies of Girton and Newnham Colleges, who have signified their intention of refraining from the contemplated appeal to the Royal Commission if it is passed before that body concludes its inquiry. The second proposal is for the admission of women to purely titular degrees. This is a concession to which the women's colleges offer uncompromising opposition. They maintain that it would not materially ease the difficulties under which the staffs of the women's colleges at present labour, and that it would leave the difference in the status of women at Oxford and at Cambridge so clear that it is unlikely to do much towards stemming the alleged increasing tendency for the abler girls to turn to Oxford. It is announced this week that the Council of the Senate has now decided to postpone the vote on the relation of women with the University from June 16th to October 20th, on account of travelling difficulties.

RATS, SHIPS, AND CREWS' QUARTERS.

At the annual meeting of the Association of Port Sanitary Authorities Dr. A. K. Chalmers, who is the medical officer to the Port Authority as well as to the City of Glasgow, introduced a discussion on what he called "de-ratisation of ships at British ports." His subject had nothing to do with the rates, and the word was, we believe, pronounced as though it were spelt with two t's; at any rate the subject debated was the destruction of rats, and, in particular, the need for some uniform method. It might be thought that the problem would be fairly simple in a self-contained place like a ship—we believe a ship to be a "place" for certain purposes—but there are difficulties, among them the obligation to use a fumigant which will not injure the cargo, and it is to be noted that it may be desirable to fumigate ships which are never completely unloaded at any one time at a British port. Another matter on which uniform practice was deemed desirable is the need for the regular destruction of rats after each voyage. Dr. Chalmers pointed out that though plague was primarily a disease of rats, there was no evidence that the rat plague in Eastern countries had diminished the number of rats; millions of rats had died of it in India, but there were as many there to-day as twenty years ago; not only were they numerically as strong, but from a bacteriological point of view their position was even stronger, since they might suffer from a chronic non-fatal but transmissible

form of the disease. Again, at Copenhagen, when the authorities set out to trap and kill rats, the average catch was about 300,000; it was rapidly reduced by half, but remained at 150,000 for some time. It appeared that as fast as rats were killed the birth rate rose; it was only by the adoption of a special policy which consisted in killing the females and liberating the males, who fought and exterminated each other, that the catch was reduced to 90,000. The general opinion of the meeting seemed to be that though it was possible to diminish the number of rats on ships it was impossible to exterminate them in the ports. Eventually a subcommittee was appointed to confer with the appropriate Government department in the hope of devising some unified method for the mitigation of the evil. A discussion also took place on hygiene in crew spaces; it was introduced by Dr. J. Howard Jones, M.O.H. Newport Port Sanitary Authority, after communications from that authority, from the Hull and Goole authority, and from the River Tyne authority had been considered. Various speakers pointed out that the crews' quarters often needed improvement, and that some ship-owners were willing to make improvements, but that the seamen themselves would need education in order to appreciate them. A committee was appointed to investigate the matter and make a report to the council.

PURE AND CLEAN MILK.

IN the JOURNAL of March 6th, 1920, p. 336, some account was given of the steps taken by certain public-spirited milk producers in this country to supply clean fresh milk free from the virus of tubercle or any other disease. For some time before March 14th, 1920, the Food Controller, acting in concert with the Ministry of Health and the Scottish Board of Health, had granted licences permitting the use of the designations "Grade A" and "Grade B" for milk of high hygienic quality. Since that date the system has been replaced by a modified plan not less exacting in its requirements. The Ministry of Health issues licences for two sorts of milk—"Grade A milk" and "Grade A (certified) milk"—and no person is allowed to use either designation save under licence by the Ministry. Our article described the conditions that must be fulfilled in the case of each kind. The licence for Grade A milk lays down strict requirements in regard to such matters as tuberculin tests for the cows, sampling of the milk, inspection of the farm, cooling of the milk on the farm, and its consignment in a sealed container labelled to show the address of the farm, the day of production, and whether from the morning or evening milking. In the case of Grade A (certified) milk further precautions are enforced. The milk, after cooling, must be bottled on the producer's premises in sterilized bottles, and labelled to show the day and time of production. Before delivery to the consumer it may not contain *B. coli* in one-tenth of a cubic centimetre (in each of two tubes) nor more than 30,000 bacteria per cubic centimetre, nor may it be delivered to the consumer as Grade A (certified) milk more than two days after the day of production. Further, it must be delivered to the purchaser in the bottles in which it has been received from the producer with caps intact. For both kinds of Grade A milk there are stringent conditions as to the employment of tuberculin for testing the health of the herd, and periodical veterinary examinations of the animals are required. Last week Dame Margaret Lloyd George opened the Grade A (Certified) Milk Dairy, recently established by the Express Dairy Company at College Farm, Finchley. The ceremony—under the chairmanship of Viscount Elveden, President of the Grade A Milk Producers' Association—was attended by a number of medical officers of health and other members of the medical profession. The visitors had an opportunity of seeing the special herd at milking time, and of observing the details of production, bottling, and laboratory control. It is of some interest to recall that a strong advocate of milk pasteurization, speaking of ideal reforms in an address delivered

thirteen years ago, laid down the following conditions which would have to be fulfilled in the technique of pure milk production: "In order to get milk with a bacterial content of less than 1,000 per cubic centimetre, such as von Behring regards as a not unattainable ideal, or even of less than 10,000, which is the standard for 'certified milk' at Rochester (N.Y.), you must be prepared to devote money and careful attention to the problem. The animals must be kept scrupulously clean. Complete asepsis must be aimed at in milking. The cows' tails, for instance, must be cleansed with an anti-septic wash. Before milking begins it ought to be possible to pass a white kid glove over the cow's udder without staining it. The milker's hands should be washed with special precautions before milking each cow, and special milking suits should be worn. A special cooling room must be available, and the milk should be filled into bottles and sealed for delivery as soon as possible. Always it must be kept cool. The bottles employed must be thoroughly cleaned and sterilized before the milk comes into them. To say nothing of the machinery required, it is obvious that all this needs conscientious workpeople." It would need but a few slight changes to turn this into a description of what actually happens to-day in the production of Grade A (certified) milk in England.

A BYWAY OF EVOLUTION.

DR. WALTER KIDD'S observations on the direction of the slope of hair on the bodies of mammals are well known to anatomists; they have extended over many years, and, did they do no more, would furnish ample evidence of his perseverance and capacity for taking pains. He has now gathered them together in a book,¹ and added many new examples. Shortly stated, his main purpose is to show how this line of evidence lends support to the Lamarckian, or rather, perhaps, the neo-Lamarckian, conception of evolution. Dr. Kidd considers that, apart from the centrifugal forces of the growing hair, the main causes of the formation of whorls, featherings, crests and other patterns of hair may be a certain centripetal force either in the form of friction, pressure, gravitation or muscular traction. These centripetal forces are the all-important factors. That muscular traction does have an influence on the direction of the individual hair is generally admitted—the erector pili muscle, for example. A more general expansion of a skin muscle, such as the platysma, can quite conceivably exert a more general effect on the hairs collectively over an area of skin. Another factor in this connexion does not appear to be mentioned—it is the shape of the individual hair on transverse section; this point is illustrated in the lie of the hair of a negro and a Malayan for example. The shape of the hair in all mammals is certainly not the same. The up-standing condition of the hair in *Choloepus*—certainly, as appears from the picture given, very striking—is attributed by the author to the effect of gravitation; but this effect is not nearly so well marked in *Bradypus*, an animal of similar habits. Moreover, the hair on the ventral surface of quadrupedal mammals, upon which gravity is constantly acting, is not erect as a general rule. Presumably Dr. Kidd would suggest that the intermittent pressure when the animal is lying down is sufficient to overcome the ever-present effect of gravity. It is, however, when one comes to examine the hair direction in horses and the author's explanation of the effects of harness that it becomes difficult to accept fully his conclusions. The evidence of the diversity of effect on the direction of the hair due to the pressure of a tightly or a loosely fitting collar, for example, is unconvincing and the critic is tempted to ask certain apparently trivial but nevertheless pertinent questions. How long, for instance,

is it necessary for a horse to wear a particular collar before a specific effect is produced on the direction of the hairs? And further, if there is a change of collar from a tightly fitting to a loosely fitting, or vice versa—as, for example, on a change of ownership—does the direction of the hair, once established, become altered? Granting, however, for the sake of argument, that these hair patterns are due to the causes stated by Dr. Kidd, the really crucial point is, What evidence is there that these acquired characters are inherited? The only evidence that, so far as we have observed, Dr. Kidd records on this point has reference to ten foals stated (p. 136) to have had the same hair pattern as their mothers: in them the particular patterns are supposed to have been produced by the harness. Though the number is small, yet, if the proof of the inheritance of the acquired character were conclusive, it would be a really important point. But in another place (Chapter V) the author describes "fourteen out of a much larger number of the most instructive varieties of pattern" which he has collected. If the varieties of pattern are so numerous, it is not surprising that a foal should sometimes be born with the same pattern as its mother. What happens if the sire has acquired a different pattern from the mare? There are too many questions to which no reply is as yet forthcoming. Dr. Kidd speaks of the "unpopular doctrine of Lamarckism." Unpopular it is only in the sense that it is not accepted for lack of scientific proof. Many biologists would welcome it were the proof satisfactory. It would solve many difficulties; it would be of vast assistance in the solution of many a problem in sociology. Such evidence is not forthcoming as yet, and it is not to be found in the volume under consideration. As has been said, the book furnishes ample evidence of the author's perseverance and enthusiasm in the collection of material; it is a pity that he introduces so much that is irrelevant and indulges in a style that is often one of unnecessary levity.

SPORT BY ARTIFICIAL LIGHT.

THE present hyperactivity of the sporting instinct is resulting in a demand for artificial illumination of games, even of games played entirely out of doors, partly that the zestful hours may be prolonged, and partly that the players may be rendered independent of the glare and vagaries of the sun. In the discussion at the Illuminating Engineering Society on May 31st, instances were given of how the artificial illumination of sports and games is being put into practice in America. In Chicago a baseball ground is illuminated at night by horizontally directed searchlights proceeding from lamps so placed around the arena that they do not, it is said, dazzle either the players or the spectators. In New Jersey, not only tennis courts in the open but even golf links have been lighted by incandescent gas. The holes on the links are painted white inside so as to be more easily visible. The artificial lighting of tennis courts is fairly well understood in this country, but night golf is something new, though there is a record of a golf match at Highgate which was finished by means of flares. It would seem feasible for golfers to practise putting by artificial light, and for cricketers to practise at the nets, although the illumination of an entire course or field might be out of the question. To judge from the discussion, however, it is the view of some promoters of sport that sunlight is considerably below artificial light in efficiency when the latter is properly distributed and controlled. In some future cricket test the wickets may fall by night instead of by day, which will bring another minor revolution into the habits of a large part of the community. In the case of indoor games the illuminating engineer is more sure of his ground. The illumination of the billiard table is already standardized. With the chess table it is different, and the loser might plausibly attribute his false moves to the dense shadows cast by the pieces when the light on the board

¹ *Initiative in Evolution*. By Walter Kidd, M.D., F.R.S.E. 1920. London: H. F. and G. Witherby. (Med. 8vo, pp. 272; 80 figures, 15s. net.)

comes from an unduly oblique angle. There is some reason to believe that the watching of the swift passage of a ball, either at tennis or cricket, in indifferent or too brilliant daylight has caused injury to eyesight; eager interest in the game has made both spectators and players oblivious of conditions of eyestrain which they would resent and correct under other circumstances. Any study of illumination in this connexion, therefore, is likely to be useful, even if it does not serve the immediate object of turning the sportsman's night into day.

CLINICAL RESEARCH IN PHARMACOLOGY.

IN 1913 Professor Brauer, who occupies the Chair of Medicine in the University of Hamburg, put forward a proposal for the establishment of a research institute for clinical pharmacology. The main underlying idea was to bring about a greater measure of co-operation between the clinician and the pharmacologist. The observations of the pharmacologist on the action of drugs on animals and human beings, if unchecked by clinical observation, are of limited value, and in some instances may be misleading. Professor Brauer failed to obtain financial aid either from the State or from chemical manufacturers, the latter professing a fear that the scientific freedom of the staff might be diminished should manufacturers contribute to the support of the proposed scheme. Nevertheless Professor Brauer obtained enough from an anonymous donor to fit up rooms at the Eppendorfer Hospital. The details published in an article in the *Deutsche medizinische Wochenschrift*, on which we have to rely, are very incomplete. It would appear that the institute, so to call it, is recognized by the university and enjoys full scientific independence.

PRESENTATION TO DR. MACDONALD.

THE presentation to Dr. J. A. Macdonald will be made during the annual meeting of the British Medical Association at Newcastle. It is therefore necessary to close the fund, and any member who intends to subscribe and has not yet done so should send his cheque to the Medical Secretary, 429, Strand, W.C.2, at once. It was during the annual meeting at Cambridge last year that Dr. Macdonald ceased to be Chairman of the Council of the Association, after holding that office for ten difficult years. He was a member of the Representative Body from the beginning, and became its chairman in 1906, so that when he was elected Chairman of Council in 1910 he already had considerable experience of the business of the Association. He never grudged time or energy in its service, and it is very fitting that the occasion should be taken to give him some tangible expression of the gratitude of its members.

WE regret to announce the death, on June 2nd, at the age of 51, of Dr. J. M. Fortescue-Brickdale, Physician to the Bristol Royal Infirmary.

Medical Notes in Parliament.

[FROM OUR PARLIAMENTARY CORRESPONDENT.]

Public Health Officers Bill.

THE private bill introduced by Sir Philip Magnus was considered on Report, on June 3rd, as amended in Standing Committee. The first clause set forth that the medical officer of health of a local authority, who by the terms of his appointment was restricted from private practice as a medical practitioner, should not be appointed for a limited period only, but should be removable by the authority with the consent of the Minister of Health, or by the Minister, but not otherwise. Sir Philip Magnus, under a promise made in Committee, moved to insert the words "in cases to which this section applies." This amendment having been agreed to, he moved as an addition to the clause the words:

This section applies to:

(a) the medical officer of health of a county borough where any portion of the salary of the medical officer was paid out of moneys voted by Parliament before it was constituted a county borough;

(b) the medical officer of health of a county district any portion of whose salary is paid out of the county fund of the county in which the district is situate and charged to the Exchequer contribution account.

On a division the amendment was carried by 100 votes to 17.

The second clause made similar provision as to tenure of office and appointment of sanitary inspectors, but with the provision that where more than one sanitary inspector was appointed by a local authority the clause should only apply to the senior sanitary inspector. Under the bill inspectors of nuisances are to be deemed and called sanitary inspectors.

Mr. John objected to the distinction between a senior and junior sanitary inspector, and moved that the section should apply to all sanitary inspectors. Sir Philip Magnus agreed with most of the arguments used by Mr. John, but said that it was absolutely essential, if the bill was to go through, that the promoters should make concessions to those authorities which some years before bought their freedom by refusing to accept any grants from the Government. That was why the application of this bill was limited both as regards medical officers of health and sanitary inspectors. It was better to have four-fifths of a loaf than no bread. Mr. John, in the circumstances, withdrew his objection, and the bill was read a third time.

The Dentists Bill.

THE Dentists Bill, introduced by the Minister of Health to give effect to the recommendations of the Departmental Committee on the Dentists Act, 1878, was taken in Grand Committee of the House of Commons on June 7th, under the chairmanship of Mr. Tuxton. The provisions were summarized in the *BRITISH MEDICAL JOURNAL* of May 14th, p. 715.

The principal discussion in Grand Committee was as to the future position of dentists at present unregistered as provided for in the bill. Under Clause I of the measure, which is to take effect not earlier than one year nor later than three years from the commencement of the Act, the practice of dentistry by unregistered dentists is to be prohibited. But existing unregistered dentists are to be given the right of admission to the register, subject to evidence of good character, if they satisfy the Dental Board (to be set up) that they have for five years out of seven immediately preceding the commencement of the Act been engaged in the practice of dentistry as their main means of livelihood, or for one year before the commencement of the Act have been members of the Incorporated Dental Society. Existing unregistered dentists who have been in practice less than five years will be required to pass an examination before admission to the register. The Board is to have dispensing power to deal with cases of persons who cannot meet the requirements of the bill by reason of military service.

Dr. Fremantle, on behalf of the British Dental Association, moved an amendment to the Admission Clause (III) to the effect that the unregistered dentists who were to be admitted as registered dentists should be placed on a separate list. His argument was that there should be some discrimination between those who had been fully trained and qualified and those who were to be registered but had not previously so qualified. This was opposed by Colonel Wedgwood and Mr. Seddon.

Sir Alfred Mond (Minister of Health) said he did not like the idea of anything suggesting a separation of sheep and goats. If the amendment were passed it would have the effect of not registering dentists whom it was intended to benefit. For that reason he could not accept it. The amendment would, indeed, if approved, wreck the measure, as it would cut to the foundations of the scheme. Earlier in the session he had refused to introduce the bill because he had understood that it was controversial, but, subject to there being a general agreement amongst those concerned, he had announced he was willing to go forward with it. Otherwise he could not do so, as the Government time was so limited.

Dr. Fremantle said he had no desire to imperil the bill, neither had the British Dental Association. He withdrew his amendment.

Mr. Seddon afterwards moved that members of the National Dental Association and the Chemists' Dental Society should be given the same right of admission to registration as were to be conceded to the Incorporated Dental Society—namely, that membership for one year before the commencement of the Act should qualify for registration. He urged that the National Dental Association had been very effective. Its members were not floating from village to village or town to town, but had permanent residence in their districts.

Mr. Acland, who was chairman of the Departmental Committee, opposed the inclusion of the National Dental Association in the provision. He did so because the witness who attended the departmental inquiry on their behalf had omitted to sign his evidence for publication. Mr. Hartshorn, for the Chemists' Dental Society, said they were prepared to accept the bill as it stood, and did not desire special inclusion.

The amendment was negatived by 26 votes to 6.

The bill, after some further discussion, was passed to be reported to the House.

It should be added that the powers of the General Medical Council, so far as they relate to the maintenance of the *Dentists Register*, will be transferred to the Dental Board, but any regulations made by that Board under the bill must be approved by the General Medical Council and the Privy Council. The Board of 13 is, in the first instance, to be wholly nominated. Afterwards six of its number shall be elected by dentists as prescribed in the schedule. Three of its appointed members will be chosen by the General Medical Council, three by the Minister of Health, and one (the chairman) by the Privy Council.

Dogs' Protection Bill.

Sir F. Banbury, a few minutes before the time for the automatic close of the sitting on June 3rd, moved the second reading of the Dogs' Protection Bill. He said that as a similar bill had already passed a second reading on three different occasions, twice without a division and once with a considerable majority, lengthy explanation was not required. Sir Watson Cheyne summarized the chief objections which the medical profession and scientists had against the bill. He and all his friends were dog lovers; it was not that they disliked dogs, but that they could not afford to lose the experience that could be gained from them. They asserted that there were many fields of knowledge that must be explored if they were to advance the science of medicine, and some of the observations that they gathered from the dog were quite necessary. The animals that were usually used in experiments fell into four classes: the small rodents—rats, mice, and guinea-pigs; dogs, and cats to a smaller extent; horses; rabbits, and apes. Other animals were only occasionally used. Rodents were almost entirely used for investigations into infectious diseases. Horses were used not so much for experiments as for commercial purposes—for the producing of serum such as tetanus antitoxin which saved so many lives in the late war. The dog and the ape were really the only two animals from which was derived the main part of our knowledge of the processes of health and disease. It was true that most of the work could be done with apes, not so conveniently in some cases, certainly not so cheaply. But one or the other must be used for various reasons. To obtain results that could be applied to the treatment of disease animals must be used whose mode of life resembled man's. Apparently it did not matter to Sir Frederick Banbury what animals were vivisected so long as they were not dogs. There were various objections to the use of apes. First, they were scarce in this country; secondly, they were not so easily handled. If a dressing were put on a dog he did not trouble so much about it; in a few hours he apparently forgot it. But the ape did not forget; he never rested satisfied until he had torn open the stitches and vitiated the whole experiment. There was the further consideration of the expense; men engaged in this sort of work were, in the great majority of cases, poor. The results got from the experiments on dogs were of the greatest value. They were the groundwork of all knowledge of the healthy processes of human nature. Physiology, the science of health, was based almost entirely on observations on dogs. Sir Watson Cheyne was still speaking when the House stood adjourned, the debate to be renewed the following Friday if the order be reached.

Glasgow Pensions Committee and the Bellahouston Inquiry.—Mr. Neil McLean, on June 2nd, put a number of questions to the Minister of Pensions as to the Glasgow War Pensions Committee which recently resigned. The Regional Director deputed an officer to take charge of the work in the area, and invited organizations of ex-service men in Glasgow to nominate members to form an advisory committee. This Committee, which meets weekly under the chairmanship of the Regional Director, is composed of ex-service men nominated by the British Legion, the Limbless Ex-Service Men's Association, the Trainees Protective and Welfare Union and the Independent Grand Order of Ex-Service Men, together with a few members of the late Divisional Committee which acted under the local committees for the subdistricts of Glasgow. On these proceedings Mr. McLean raised two separate points. He asked, in the first instance, whether notices of dismissal had been served on certain officials of the clerical staff of the department in Glasgow, and he suggested that these notices should be suspended in view of the public inquiry into administration at Bellahouston Hospital. Mr. Macpherson, in his answer, stated that it had been found necessary for efficiency and economy to reorganize business in the local office, and certain officials, whose services were not required, were given notice; all the files needed for the inquiry would be available. Mr. McLean's second point was as to certain reports which appeared in the Glasgow papers from the ex-service men's Advisory Committee, describing conditions in Bellahouston Hospital as satisfactory, such statements being liable to prejudice the inquiry. Mr. Macpherson replied that Bellahouston Hospital had not been

under the direct management of the Local Committee, but of the Joint Disablement Committee for the South-West of Scotland. He was informed, however, that the Advisory Committee obtained permission from the Regional Director to send two deputations to visit that hospital. On receipt of their reports the Advisory Committee placed on record their satisfaction at the general arrangements of the hospital without desiring to anticipate the inquiry. He was not aware that the action of the Advisory Committee was regarded as an attempt to prejudice the inquiry; nor, in view of the fact that the great majority of men under treatment at Bellahouston were natives of Glasgow, and obtained their treatment at the hospital through the local War Pensions Committee, did it seem at all unreasonable that the Advisory Committee should decide to ascertain for themselves that the existing conditions of treatment were satisfactory. Mr. Barnes asked whether the dismissal of some of the clerical staff of the local War Pensions Department in Glasgow had any connexion with the alleged irregularities in Bellahouston Hospital. Mr. Macpherson stated that they had not. The Glasgow Local War Pensions Committee had nothing to do with Bellahouston Hospital; that hospital was under the Glasgow and West of Scotland Joint Disablement Committee.

Colonial Medical Services.—Dr. Fremantle asked, on June 1st, when the Colonial Secretary proposed to publish the evidence given before the Departmental Committee appointed by his predecessor to inquire into the Colonial Medical Services; and whether he would give a return showing the number of medical appointments vacant in the various colonies under the Crown and stating the steps being taken to fill them. Mr. E. Wood, Under Secretary for the Colonies, replied that it was not possible to publish the evidence, as some of the witnesses were assured that it would not be published, and without that assurance that evidence would not have been given as freely as was desirable. He would consider whether the return suggested could usefully be given. Dr. Fremantle asked whether the Colonial Secretary intended to appoint a Director-General of the Colonial Medical Service, who would, *inter alia*, advise the Minister and permanent staff of the Colonial Office as to all questions relating to the personnel of the Colonial Medical Service. Mr. Wood said that as the recommendations of the committee were at present being considered in connexion with the observations of the Colonial Governments he could not make any statement as to the decision to appoint a Director-General of the Colonial Medical Service. Dr. Fremantle asked whether the Colonial Secretary had sanctioned a minimum salary of £600 per annum, with pension, for colonial medical officers, as recommended in the report of the Colonial Services Medical Committee. Mr. Wood replied in the negative. He said the differences in the resources of the several colonies were so great and the conditions under which their medical officers served so diverse, that he saw no prospect of its being possible to insist that Colonial Governments should adopt the minimum named as a hard-and-fast rule. In a number of the most prosperous colonies the local Governments had adopted and in some cases exceeded the minimum. Dr. Fremantle asked if it was conceivable that any decent respectable medical man could be obtained to go abroad for a less salary than that amount. The Speaker observed that that did not arise out of the question.

National Insurance Administration.—Sir A. Mond stated, on June 1st, on the inquiry by Mr. Wilkie and Sir T. Bransdon, that he hoped at an early date to introduce a bill to give effect to the recommendations of the Departmental Committee on National Insurance Administration. The Ministry of Health has informed Mr. Hodge as regards the increase in the cost of administration for the insurance section of the Ministry as between 1914 and 1920—that is, prior to July, 1919—the central administration was in the hands of the Insurance Commissioners, and has since formed part of the work of the Ministry of Health, it was impossible to give the precise cost of the administration in 1920. No useful comparison could be made between the cost in 1914 and 1920, as throughout the latter year the department was engaged in the very laborious operation of the preparation of the fresh valuation of approved societies.

Insurance Practitioner's Refusal to Disclose.—Sir A. Holbrook asked, on June 2nd, whether the Insurance Committee of the area comprising Bramley, near Basingstoke, had received information that a portion of the Exchequer grant payable to it could be withheld in consequence of a local practitioner having declined to give information detrimental to one of his patients, acquired by him in the course of his duties, such information having been called for at the behest of a rich corporation with whom the man was insured; and whether the Minister of Health would take action to secure that a doctor should not be penalized for doing his duty to his patient. Sir A. Menl replied that in the case to which the question appeared to refer an approved Society sought to obtain the opinion of the medical referee of the Ministry on the question of the incapacity for work of one of their members who was claiming sickness benefit. The insurance practitioner had definitely declined to give any particulars as to the history and condition of the patient likely to assist the medical referee, notwithstanding the provision in his terms of service, which clearly required him to do this. In these circumstances it had become necessary to inform the doctor that a portion of the Exchequer grant, forming part of his remuneration, must be withheld, the grant being payable only if the terms of service were complied with. But in accordance with the provisions of the regulations, any representations which the doctor wished to make in the matter would first be considered.

Ministry of Health: Reorganization.—Sir A. Mond, in answer to Sir S. Hoare, on June 2nd, said that the reorganization scheme of the Ministry of Health was not yet in operation. Throughout the public service, supervising assistant clerks had been assimilated into the higher clerical class, intermediate clerks into the executive class, and first class women clerks into the clerical class. The question of the transfer of any of the first class women clerks to the executive class or the higher clerical class would be considered when the number of such posts arising out of the pending reorganization was known.

Pension Patients in Mental Hospitals.—Mr. John Davison asked the Minister of Pensions, on May 31st, whether in any of the mental hospitals under his control methods of treatment advised by medical officers had been withheld from patients, and, if so, on what grounds; whether schemes of employment suitable for patients were in operation in these hospitals, and, if not, whether such schemes would be instituted. Mr. Macpherson replied that he had no knowledge of any instances in which treatment advised by responsible medical officers had been withheld from patients in hospitals under the control of his department for the treatment of neurasthenia and other mental disorders which were not certifiable under the Lunacy Acts. In the majority of these institutions suitable occupational treatment had already been provided, and it was hoped that it might be found possible to extend the arrangement for the remainder.

VOLUNTARY HOSPITALS COMMITTEE.

The Voluntary Hospitals Committee, over which Viscount Cave presided, was appointed on January 25th "to consider the present financial position of the voluntary hospitals and to make recommendations as to any action which should be taken to assist them." The members of the Committee were Lord Linlithgow, Sir Clarendon Hyde, Sir W. B. Peat, Mr. Vernon Hartshorn, M.P., and Mr. R. C. Norman. The Committee has now completed its report, of which we are enabled to give the following preliminary account.

The report points out that the present financial difficulties of the hospitals are due to the war. The receipts from voluntary subscriptions, donations, and legacies have not fallen off—they have, on the contrary, risen by 67 per cent. since 1913—but during the war the cost of provisions, drugs, dressings, fuel, and labour increased to such an extent that the expenditure of the hospitals has increased by 138 per cent. since 1913. The aggregate deficits of all the voluntary hospitals of Great Britain for the present year are estimated at £1,000,000.

The Committee recognizes that the voluntary system is temporarily in jeopardy, and asks, "Is the voluntary system worth saving?" The answer is, "We are convinced that it is." Apart from the immense sum of voluntary subscriptions and donations (estimated at £3,000,000 a year), the voluntary system secures gratuitous and skilled service, both lay and medical, of inestimable value. It preserves freedom in medicine, and is of inestimable value to the welfare of the sick, the training of the medical profession, and the progress of medical research. The breakdown of the voluntary system would imperil these services and impose a constantly growing charge upon public funds.

It will be remembered that the Committee issued an interim report in March,¹ in the course of which it stated that the evidence already received had convinced it that it was desirable, in the public interest, to maintain the voluntary system of hospital management, and also that, mainly owing to the large increase during and since the war of salaries and wages, and the cost of provisions and materials, the hospitals were faced with a serious deficiency of income to meet the necessary expenditure. The interim report recommended as a pressing matter that the schemes to be approved for the distribution of the surplus disclosed at the quinquennial valuation of approved societies under the National Insurance Acts, should provide for the application of a substantial part of the surplus in making a contribution towards the cost of the maintenance of members of the societies in hospitals. This was recommended in the interests both of the hospitals and of the societies.

The Committee now expresses the opinion that if the voluntary hospitals are to be saved immediate assistance

must be given by the State, such assistance to be strictly limited to a definite period of two years, and to be given only to hospitals which show that they are taking all possible steps to re-establish their financial position. A grant so limited and conditioned would re-establish the hospitals in the self-supporting position which they occupied before the war, and would not be inconsistent with the maintenance of the voluntary system.

The Committee draws attention to a number of steps which managers of voluntary hospitals can themselves take to improve the financial position of the hospitals under their charge—for example, review of expenditure, particularly in the light of comparative costs which could be ascertained by the general adoption of a uniform system of accounts; co-operative buying of drugs, apparatus, stores, and some kinds of provisions; removal of convalescent cases to auxiliary hospitals; co-ordination of appeals for subscriptions; further development of new sources of income, such as subscriptions from wage earners and employers, and other contributory schemes, examples of which are quoted in the report; contributions from approved societies.

The following recommendations, if adopted, will require legislation or executive action:

1. That a Hospital Commission should be set up by the Minister of Health.
2. That Voluntary Hospitals Committees be formed in each county and county borough; the King Edward's Hospital Fund for London to perform the functions of a Voluntary Hospitals Committee for the Metropolitan Police District.
3. That Poor Law guardians be authorized to enter into arrangements as to the use of infirmaries.
4. That county councils be empowered to contribute to the expenses of Voluntary Hospitals Committees.
5. That failing the provision in the National Health Insurance Acts of a "hospital benefit," the Courts be authorized to award to hospitals compensation under the Employers' Liability and Workmen's Compensation Acts.
6. That local authorities be authorized to pay the cost of the treatment in hospitals of persons in their employ.
7. That the payment out of technical education funds of grants for the training of nurses be considered.
8. That provision be made for obtaining and tabulating returns of cases treated in hospitals.
9. That all contributions by employers to hospital funds be allowed as deductions from profits for income tax purposes.
10. That where the payment to a hospital of a testamentary gift of residue is delayed for more than a year, the hospital be authorized to claim repayment of income tax.
11. That legacy and succession duty on testamentary gifts to hospitals be remitted.
12. That Parliament be asked to sanction a temporary grant of £1,000,000 to be expended under the direction of the Hospitals Commission in the assistance of hospitals which require it.

13. That the Hospitals Commission be authorized during a period of two years to recommend grants for the extension and improvement of hospitals, subject to like contributions being made from private sources.

The intention would appear to be that the Hospital Commission should consist of the ablest workers in various leading organizations, philanthropic and medical, that have been identified with hospital services. It is proposed that the Hospital Committee to be set up for each county council, county borough or other area as may be desirable, for arranging as to organization, shall consist of not less than nine persons; in London advantage will be taken of the existence of King Edward's Fund to entrust the work to the Committee of that body.

The intention of the proposal to empower county councils to contribute towards the expenses of Voluntary Hospitals Committees is that county councils should become one of a number of new sources of support for hospitals.

The recommendation in paragraph 3 above, that the Poor Law guardians should be authorized to enter into arrangements as to the use of infirmaries, has reference to the utilization of vacant beds, but does not, we understand, imply any general taking over of the Poor Law infirmaries. The section of the report in which these matters are discussed is voluminous, and will require careful consideration.

¹ BRITISH MEDICAL JOURNAL, March 26th, 1921, p. 468.

England and Wales.

THE LEEDS DEPARTMENT OF PATHOLOGY.

IMPORTANT developments in the department of pathology of the University of Leeds have been steadily going on for a good many years, and some of the more important of them are of recent date. There was a time, and that not very long ago, when there was no definite connexion between the university and the infirmary in respect of pathological work. The autopsies were made by the assistant physicians, who of course afforded all facilities to the professor of pathology. Not only so, but Dr. Jacob and Dr. Trevelyan, who in succession held the position of professor of pathology, were themselves assistant physicians to the infirmary during a part of the time of their tenure of office. When Dr. Leyten was appointed professor, a rule was passed by the infirmary, on the recommendation of the faculty, which practically secured for the holder of the post a place within the walls of the infirmary, and as it was and is rather quaintly expressed in the rules of the infirmary, "Every candidate for the office of pathologist shall hold the position of professor of pathology and bacteriology in the University of Leeds." The members of the assistant staff continued to make autopsies, two days a week being allotted to the professor. It was regarded as a very valuable part of the duty of an assistant physician that some work of this kind should fall to his lot, and it was deemed desirable that a good many of the autopsies should be made by those who were fully in touch with clinical work. The clinical and pathological laboratory at the infirmary was under the charge of Dr. Matthew J. Stewart. During Dr. Leyten's tenure of office as professor of pathology at the university important changes were made, and under special arrangements a large amount of work was done for the Corporation of Leeds and for various centres in the rest of Yorkshire. When Dr. Leyten's regretted illness led to his resignation of the chair, Dr. Stewart was appointed by the council of the university as his successor. In harmony with the rule quoted above he was soon elected pathologist to the infirmary, and it was further arranged that, though the work in the *post-mortem* room was still to be done by several different members of the staff, Dr. Stewart should, as official pathologist to the infirmary, be responsible for the general supervision of the work in the clinical and pathological laboratories of the infirmary.

An arrangement has been entered into by the university, the infirmary and the Corporation of Leeds for the amalgamation of their various pathological interests. Professor Stewart is the responsible working head of this conjoint department, and there is an advisory committee representative of the three bodies, to which he submits an annual report. This report is before us. The staff includes, in addition to Professor Stewart, who is also "city bacteriologist," the lecturer in bacteriology, J. W. McLeod, O.B.E., M.B., Ch.B.; the lecturer in pathology, W. MacAdam, M.A., B.Sc., M.D., Ch.B., M.R.C.P., D.P.H.; the demonstrator in pathology, J. Gordon, M.B., Ch.B.; the demonstrator in bacteriology and public health, G. A. Wyon, B.Sc.Lond., M.D., Ch.B.Edin.; the demonstrators in pathology and bacteriology, H. H. Gleave, M.B., Ch.B.Leeds, and H. V. Phelton, M.B., Ch.B.Leeds; and P. L. Sutherland, M.B., D.Sc., who is the lecturer on industrial diseases. There are also two honorary demonstrators in pathology—namely, Dr. Gruner and Mrs. Clara Stewart. The two honorary demonstrators in medical and surgical pathology are acting members of the assistant staff of the infirmary, and this arrangement is regarded as being very important and as securing that there shall be on the pathological staff men who are in daily touch with clinical work. They hold regular museum classes.

The report to which we have referred gives an admirable summary of the work carried out in the joint department. For the infirmary, 520 autopsies have been performed; 4,199 specimens (not including those from the venereal diseases department) have been examined; of these 2,321 were pathological and 1,873 were bacteriological. Dr. MacAdam is responsible, under Professor Stewart, for the work in the laboratories at the infirmary, where he is assisted by Dr. Gleave, and members of the honorary staff are pleased to have the valuable assistance of one who is a

trained chemical pathologist and a keen investigator. All the bacteriological work of the infirmary is carried out at the extension of the department of pathology, which is situated in St. George's House, adjoining the medical school, where Mr. McLeod, Mr. Wyon and Mr. Gordon act under the professor. The bacteriological work for the Public Health Department of the City of Leeds has been carried out in terms of the agreement with the Corporation, and 3,848 specimens have been examined. The work under the venereal diseases regulations has been carried out during the year for the boroughs of Leeds, Hull and Middlesbrough, and for part of the year, for the City of York; altogether 11,406 specimens have been reported on. Some work has been done for the Ministry of Pensions. A further bond of union between the infirmary and the university is expressed in the conferring by the Board of the Infirmary of the titles of assistant bacteriologist and assistant pathologist on those who hold the lectureships on these subjects. It is pointed out that the pathological and bacteriological work is thus carried on in three places—namely, in the medical school of the university, in its extension in St. George's House and at the infirmary. It would be by no means a wise thing to work towards the complete concentration of the laboratory work either at the infirmary or at the university, but it would indeed be a great advance if, apart from the making of autopsies and those examinations which subserve a clinical purpose, all the work could be concentrated in one central institute, and this is what is in the minds of many who are far-seeing and hopeful.

LEEDS WORKPEOPLE'S HOSPITAL FUND.

The thirty-fourth annual report of the Leeds Workpeople's Hospital Fund presents many gratifying features. The total income from all sources during the year 1920 was £39,739, which is an increase of nearly £14,000 over the year 1919. The main source of income, and the most reliable, is the weekly collections from the various workshops in the city; they amounted to £28,505, which was £9,511 more than in 1919; this proves that the appeal to the workpeople to increase their weekly subscriptions has been largely responded to. Collections in public houses, school collections, competitions and other efforts, including the annual gala, make up the rest of the income. Carried over from 1919 was the sum of £1,936. From this total of about £41,000 grants were made to the various charitable institutions of the city. The General Infirmary received the handsome grant of £20,000, an increase of £10,000 over last year; the Leeds Public Dispensary received £3,000; the Hospital for Women £2,500; the Leeds Maternity Hospital £1,000; the District Nursing Association £800, and smaller institutions various sums from £200 to £50. The Fund also concerns itself with the support of convalescent homes; one of these is for men, and to it 785 patients were admitted during last year; two others for women are situated at Ilkley, and to these 539 patients were admitted. The benefits of these homes are confined to the subscribers to the Fund, and there is no doubt that the popularity of the Fund as a whole has been greatly enhanced by their institution, though, when it was begun, it appeared to some that the character of the organization was being somewhat altered from that which prevailed in the first instance, when the only object aimed at was the provision of money for the charitable institutions of the city.

BRISTOL UNIVERSITY.

As briefly announced in last week's JOURNAL, the University of Bristol has received with deep regret the announcement of the impending resignation of Sir Isambard Owen, M.D., the Vice-Chancellor. It will take effect at the end of the current year, owing to the new rules of the Treasury with regard to superannuation. Sir Isambard Owen, before he went to Bristol, had associations with the West, for he was born near Chipstow in Monmouthshire, and spent much of his boyhood at Gloucester. At the time when he was physician and lecturer in medicine at St. George's Hospital, he took a prominent part in the steps which led to the establishment of the University of Wales. In 1904 he gave up active practice to become Principal of Armstrong College, Newcastle-upon-Tyne. His experience in the reconstitution of the University of Durham proved of great value to him after his appointment in 1909 as Vice-Chancellor of Bristol

University. His powers of organization had full play at Bristol. During his twelve years' work in the internal administration of the university he has found time to promote in many ways the interests of the university and enlist for it public support in the wide area which it serves in the western counties.

INTERNATIONAL TUBERCULOSIS CONFERENCE IN LONDON.

An international conference on tuberculosis will be held in London at the Institution of Civil Engineers, Westminster, from July 26th to July 28th. The National Association for the Prevention of Tuberculosis, which represents Great Britain and Ireland on the Council of the International Union against Tuberculosis, has decided to merge its annual conference in the international meeting and will act as host. The International Union is the successor of the International Tuberculosis Conference which, down to 1913, assembled annually in one or other of the capitals of Europe or in America, and its purpose is to achieve an effective combination of the nations of the world against tuberculosis. The conference is open to members of the International Union against Tuberculosis and to official delegates from countries within the League of Nations and from the United States of America, and also to representatives from all authorities interested in the subject, to whom a fee of one guinea (to include a copy of the Transactions) is charged. The President of the International Union for the current year is M. Léon Bourgeois, President of the French Senate, who will be succeeded on the occasion of the conference in London by Professor Sir Robert Philip, of Edinburgh. The conference is to be welcomed to London on behalf of the Government by Lord Curzon of Kedleston and Sir Alfred Mond, Minister of Health. Addresses will be given at the opening meeting of the conference by M. Léon Bourgeois and Colonel George Bushnell, of the United States Army Medical Corps. The subjects for discussion include "The modes of diffusion of tuberculosis throughout the races of the world," to be opened by Professor Calmette, of the Pasteur Institute, Paris, and "The rôle of the medical profession in the prevention of tuberculosis," to be opened by Sir Humphry Rolleston, followed by Sir George Newman, Chief Medical Officer, Ministry of Health. The Lord Mayor of London will give a reception in honour of the International Union at the Mansion House on July 26th, and other social functions and visits to institutions of special interest are being arranged.

Scotland.

BELLAHOUSTON HOSPITAL.

It was mentioned last week that the Minister of Pensions had appointed a committee to inquire into the management of Bellahouston Hospital by the Ministry of Pensions and the Joint Disablement Committee for the South-West of Scotland. Questions upon the subject which have been put and answered in Parliament have been reported from time to time, but it will be interesting to summarize the position; for the following information we are indebted to the files of the *Glasgow Herald*.

The question at issue, it would appear, is one of the administration and indirectly of the efficiency of the out-patient department of Bellahouston Hospital, an institution maintained by the Ministry of Pensions. Its staff is paid by the Ministry; the indoor surgical and medical staff is drawn from physicians and surgeons, both senior and junior, who are on the staffs of the three large Glasgow voluntary hospitals, and these physicians and surgeons are men in the first rank in Glasgow. While the hospital is an institution belonging to the Ministry of Pensions it is nominally managed by the Joint (Disablement) Committees for the South-West of Scotland, composed of members elected by the Local War Pensions Committees, certain other organizations, and discharged men. This managing body has among its members many of the best known men in civil life in Glasgow, men who have occupied the highest position in municipal affairs: Sir Thomas Dunlop, G.B.E., Sir A. M'Innes Shaw, C.B., Sir John Samuel, K.B.E., and Sir Charles J. Cleland, chairman of the

Education Committee, who is chairman also of the above Committee.

The chairman of the committee alleged in the press that the Ministry of Pensions for some considerable time had been limiting the power of the committee until now it was wellnigh shorn of every vestige of authority. The dismissals, numbering as many as 900 out-patient patients, mentioned by Mr. Neil McLean, M.P., in his question addressed to the Ministry of Pensions on April 14th, came as a surprise to the committee, and were ordered without its knowledge or consent. The chairman stated in the press that the state of affairs which led to the dismissal of these pensioners was entirely due to the repeated refusals of the Ministry to act upon strong representations from the committee for an adequate medical and surgical staff in the out-patient department.

The Ministry replied on April 21st, pointing out that as long ago as September last instructions had been sent to Bellahouston that the entire medical staff of the hospital could be made available for out-patient as well as for in-patient treatment; the fact that these instructions were not carried out, necessitated the intervention of the Commissioner of Medical Services in December. The medical superintendent of the hospital, in consultation with the Commissioner of Medical Services, provided a remedy for the defective working of the out-patient department by making available the services of other members of the medical staff of the hospital for the examination and treatment of out-patients; the Minister went on to say that if the Joint Disablement Committee were ignorant of the alleged dismissals of the out-patients, then there was serious ground for anxiety as to the effectiveness of the supervision of the hospital exercised by the committee.

Sir Charles Cleland, on behalf of the committee, replied to the Ministry on April 26th. The reply is much too long to quote, and we can note one point only. Sir Charles Cleland asks: "Why, when the superintendent of the hospital proceeded to clear out the out-patient department, he did not obtain the services of some of the visiting staff instead of the services of the junior resident staff? . . . The position as regards the discharges from the out-patient department is that the newly appointed medical superintendent, with the aid of members of the junior staff, examined about 2,000 patients between February 5th and February 12th, and discharged about 953 as fit for work. Many of these cases were sent back to hospital on stretchers and in ambulances within 48 hours." This letter, dated April 26th, contains the names of 12 members of the committee who have intimated their resignation, and our information is that since the date of that letter, on April 28th, the Corporation of Glasgow appointed a committee to approach the Government to set up a public inquiry into the situation at Bellahouston Hospital, with the result mentioned last week that a committee of inquiry, with Lord Scott Dickson, Lord Justice-Clerk of Scotland, as chairman, has been appointed. It held its first meeting on June 6th. Since the resignation of members of the voluntary committee, Colonel Warden, Regional Director, Ministry of Pensions, has adopted means whereby the interests of the patients at Bellahouston will be looked after.

Ireland.

ROYAL VICTORIA HOSPITAL, BELFAST.

At the meeting of the board of management of the Royal Victoria Hospital, Belfast, on June 1st, the notification of the resignation, under the age limit rule, of Professor James A. Lindsay, M.D., F.R.C.P., senior physician, was received with great regret, and he was appointed to the consulting staff. Dr. J. E. MacIlwaine, senior out-patient physician, was elected to fill the vacancy, and an election for assistant physician will be held on June 15th. On the recommendation of the medical staff, Professor Lindsay will probably be asked to deliver clinical lectures at the hospital during the teaching session.

DR. F. B. POWER was recently presented at a meeting in Washington with a gold medal, to commemorate his services as director of the Wellcome Chemical Research Laboratories, London. The presentation was made by Mr. Henry S. Wellcome.

Correspondence.

CAPILLARY PRESSURE.

SIR,—I have read Dr. Leonard Hill's lecture on capillary pressure and oedema, published in your issue of May 28th, 1921, and am amazed that a man of his eminence could be guilty of so much fallacious reasoning through failing to take account of some elementary facts in physics.

In paragraph 2 he states his belief that the pressure of the brain against the skull is a measure of the pressure in the arterioles and capillaries within the brain; and in paragraph 3, that the pressure of the cerebro-spinal fluid is the same as the above, and practically the same as the pressure in the cerebral veins. He might as well give the height of the barometer in a garden as a measure of the pressure in a hose-pipe at work in the garden.

When two portions of fluid are separated by a membrane on the stretch the pressures of the fluids at two opposed points are not equal unless the membrane have plane surfaces at the place. If the membrane be concave on one side and convex on the other—as, for example, in a soap bubble—the pressure on the concave side is greater than that on the convex side. With a given tension in the membrane, the smaller the radius of curvature of the curved surface the greater the difference of pressure on the two sides. When the curved surface has the form of a tube the inside pressure exceeds the outside pressure by $\frac{T}{R}$, where

T = the tension per unit of length tending to split the tube longitudinally, and
 R = the radius of the tube.

This may be expressed by the equation

$$p_1 - p_2 = \frac{T}{R}$$

p_1 and p_2 representing inside and outside pressures respectively.

Now the walls of capillaries are incapable of sustaining much tension; but, their radius being very small, about 0.000005 cm., a small tension can maintain a considerable difference of pressure between inside and outside. Thus, using c.g.s. units—

Let $p_1 - p_2$ = the pressure caused by 50 mm. of Hg.
 = 5×13.6 grams per sq. cm.
 = 68 grams per sq. cm.

Then $68 = \frac{T}{0.000005}$

and $T = 0.00034$ grams per cm. of length.
 = 0.34 milligrams per cm. of length.

The maintenance of a considerable pressure in the capillaries, above that of the surrounding tissues, by a small tension in their walls, does not appear to have occurred to Dr. Hill. The walls of capillaries being so thin and collapsible, they are kept open only by having a higher pressure inside than outside. As they have no muscle cells in their wall, their diameter depends largely on this difference of pressure distending them more or less as the case may be.

Dr. Hill has also failed to take fully into account that the blood is not a simple fluid, but consists largely of corpuscles not much less in diameter than the capillaries. When he makes a slight increase in the outside pressure in his modification of the Roy and Brown apparatus described in paragraph 17, this causes a diminution of the tension in the capillary walls, resulting in a diminution of calibre, which causes a slowing of the current, although he may not have made the outside pressure anything like as great as the inside pressure, as he wrongly assumes he has done in paragraph 19. Even when he has increased the pressure so as to stop the flow of corpuscles through a capillary, he has probably not made the outside pressure equal to the inside pressure, but only reduced the calibre of the capillary to that of a corpuscle which then blocks it.

There are several other points in the lecture which I should like to criticize, particularly the explanations of certain phenomena in the eye given in paragraphs 5 and 6, but I fear you will think my letter already too long.—I am, etc.,

JOHN R. GILLESPIE, M.A., M.D.

Knock, Belfast, May 31st.

THE PREPARATION OF SCIENTIFIC PAPERS.

SIR,—I have received to-day the JOURNAL of May 21st. Without waiting till my return home next week, I wish to thank mildly Dr. C. O. Hawthorne for his instructive criticism. To one who used to read his writings until driven off by his verbosity, it is very satisfactory to learn that he now intends to get rid of all superfluities.

"Should have found it necessary." Here the *it* is not redundant, but is essential to represent the thing which was necessary. There is a difference between having an independent opinion and having got one for an express purpose, though he does not seem to think so. Let him substitute *idea*, or any other appropriate word, and perhaps he will appreciate the difference. I have got a variety of paper fasteners, some very ordinary and others rather uncommon, but none with me on my journeyings, otherwise I might have sent him a sample.

I am obliged to him for looking up the double verification of the tower in Siloam. I am sorry he had not a much-needed dip in the pool. You may have a painting "in oils," or "in water colours," but an artist works with his brushes and a variety of paints. I must thank him for drawing attention to the split infinitive, an error into which I do not often tumble. To express strongly, which he suggests, implies the use of strong language, which is foreign to my nature, and certainly outside the vocabulary of a child. Another critic, who does not appear in print, suggests that I should have said, wished strongly. This would have been an egregious mistake, as I have no standard to measure the strength of my own wishes, and I would not attempt to gauge those of another. It would seem, therefore, that for accuracy of expression there is nothing left but either to break the rule of the grammarian or to omit, strongly. The little personal embellishments presented by this person, supercilious in appearance and in character, I can afford to ignore, especially as I am not living in a London fog. I have not followed his example, and so I have eschewed all repetition of his name, having found the personal pronoun quite sufficient.

I am very pleased to have this opportunity of pointing out an error in my letter which seems to have escaped the notice of others. I used the genitive singular, *speciei*, where I intended to use the nominative plural. I was using so many genitives that I suppose this one crept in inadvertently.—I am, etc.,

Dinard St. Enogat, June 3rd.

JAMES BARR.

THE PREVENTION OF PUERPERAL INFECTION.

SIR,—The discussion on this subject is of exceptional interest to the general practitioner, and ought to be of immense profit to him as well. The opinion of the general practitioner, who does the large proportion of the midwifery practice of the country, is surely of some value, but probably the most successful do not bother to express their opinions. I have attended a good number of cases—being at present well in the second thousand—under all sorts of conditions and with the assistance of all sorts of nurses. I have had trouble with sepsis, including one case of death from pyaemia, which I would not wish to occur to my worst enemy; it takes more out of a conscientious man than six months' ordinary work.

In my earlier cases I was all in favour of "leaving things to Nature," which counsel was given me by several shrewd practitioners of many years' standing. My later cases have been absolutely differently conducted, the principle being "get the labour finished as soon as possible." The latter I find the more successful by far, for it has most certainly not increased the morbidity, while at the same time it has won the gratitude and approval of the patients and their friends and saved me valuable time.

The one case of death from pyaemia was a 6 para. I never made a vaginal examination. I arrived in the room as the head was passing over the perineum; the placenta came away perfectly, and there was only a slight perineal laceration which I then considered not serious enough to require a stitch. From this case and others in which there has been a slight rise of temperature I am satisfied that perineal lacerations are the biggest factor in the production of sepsis; they get infected from the vulva, napkins, etc., and it is easy to see the danger of such infected wounds when there is the raw placental surface

at no great distance, and the interval is often bridged with blood clot. Iodoform and boracic powder should be freely used, and a vaginal douche given night and morning. My advice is: Watch the perineum, and even if you arrive when the confinement is completed, do not believe the nurse, but see for yourself that the perineum is all right, and your morbidity will decrease by 50 per cent.

The second point I wish to emphasize is this: the third stage should not be rushed. One should wait at least half an hour if there is no hæmorrhage, and if gentle pressure will not expel the placenta it is much safer to wash carefully and remove it manually than to use excessive force, with the risk of leaving a piece behind or tearing off the membranes. These manipulations rarely cause trouble; for, first, special care is taken to wash both one's hands and the patient; and secondly, no one should think of leaving such a case without giving an intrauterine douche of several quarts of lysol solution, and leaving instructions for a vaginal douche to be given night and morning for several days at least.

Thirdly, in multiparæ, when the first stage is passed, the pelvis normal, and the presentation straightforward, pituitrin $\frac{1}{2}$ to 1 c.cm. with chloroform is to be preferred to forceps. The results are most gratifying to all concerned, and no amount of academic reasoning will convince to the contrary the man who has used it with the necessary caution in any considerable number of cases. Pituitrin expels not only the baby and the placenta, but also blood clot; and when ergot is given after the third stage, an empty and well contracted uterus is the result.

On the other hand, if pituitrin is contraindicated—and it must not be used indiscriminately—why be afraid to use forceps? The second stage can often be terminated in a few minutes, and it is unnecessary to do more than to insert two fingers for about one inch into the vagina to apply the forceps successfully. It is criminal to use unsterilized forceps, and surely every man is taught how to wash up both himself and the patient and pass a catheter.

In a primipara one may sit for two hours or more watching the head bobbing into and out of the vagina, the perineum stretching a little more with each pain till, at the end of the long wait, the last pain gets the head through far enough to begin a tear of the perineum, which is so thinned out that it rips down to the rectum rapidly and the baby is born. It seems to me that this bobbing in and out of the head is as dangerous as the insertion of two aseptic fingers and along these the sterilized forceps, which need never touch hair or skin. And, I believe, with skill, the perineum will be saved as often with forceps as with natural termination.

The great point is not to leave things to Nature—which is quite out of date—but get the second stage over as painlessly as possible, provided that if forceps are used they are followed by thorough douching, preferably intrauterine.

The cases in which the hand has been inserted are certainly not those most likely to go wrong. This is my experience and the experience of others with whom I have talked; the reason is that thorough douching has followed and aseptic precautions have been taken. The simple cases, where there has been no interference, go wrong far more frequently—the simple perineal laceration is overlooked, becomes septic, and leads to sapsæmia, and possibly septicaemia. But the douching must on no account be left to the nurse. I witnessed one "skilled" female push the basin of antiseptic up to the patient and proceed to syringe the lotion into the vagina, allowing it to return from the vagina into the basin! And still we are puzzled as to the cause of sepsis? The great trouble is, in fact, that many patients cannot afford to pay proper nurses. The vaseline on the patient's vulva indicates that the nurse has made at least one, if not a dozen, vaginal examinations before the doctor's arrival with his antiseptic. Further, I personally never like to attend a case with a midwife who is herself attending a number of other cases, for one is apt to leave too much to her, and, on the other hand, she is not so careful when a doctor is there to share responsibility and blame. This is why these cases do not do so well as when the midwife herself attends alone.

To sum up the points I wish to emphasize:

1. Get the second stage over as painlessly as possible. If the patient is not having morphine and hyoscine, pituitrin

may be used in suitable cases or forceps, provided always that the doctor himself follows the forceps immediately with thorough douching.

2. Do not rush the third stage; empty the uterus manually without hesitation, but follow this with a thorough intrauterine douche.

3. It is most important to take great care with all perineal lacerations; such lacerations precede a very large number of septic cases. The vagina should be douched before and after repair, and iodoform and boracic powder should be freely used.

Success in preventing puerperal sepsis does not await any new discovery, but depends on attention to well-known details, and I have been well repaid by attention to the above points.—I am, etc.,

Iford, E., May 23rd.

N. BEATTIE, M.D.

SIR,—During the years 1913 to 1920, while in charge of a maternity hospital in India, I had considerable opportunities for studying the above subject. It is in the hope that my experience may be of some value to others that I venture to address you.

When taking over charge of this institution I found that sepsis was by far the commonest cause of death in the obstetric practice of the hospital, and this was not surprising, as the majority of cases had already been examined by untrained midwives of the barber caste before admission.

In combating this state of affairs, the introduction of gloves, a strict aseptic ritual, and the restriction of vaginal examination to complicated cases by a competent obstetrical medical officer, played their part. But there remained a certain number of infected cases which, in spite of an empty uterus, intrauterine douching, etc., ended fatally. In several such cases I removed the uterus, but only one of these recovered, and I came to the conclusion that by the time I could make up my mind that such a severe measure was necessary either the local infection had spread too far or the patient's infection had become too severe for there to be a reasonable chance of recovery. It is only necessary to examine a uterus so removed to be convinced of the futility of curetting an infected uterus.

At this time I had started using the Carrel-Dakin method in my general surgical wards for the treatment of infected wounds, and was very pleased with the results obtained. I decided to give the method a trial in cases of puerperal sepsis.

Method.

After trying various techniques, it was found that the solution could be best applied to the infected uterus by means of a rubber tube, the two ends of a suitably sized tube being attached to two arms of a Y-shaped glass tube, the distal three inches or so of the loop thus formed being perforated with numerous holes and placed in the uterus. The Y tube being of course outside the vagina, had its stem connected up by means of a rubber tube, with an irrigator containing Dakin's solution. The flow of the solution was controlled by a clip on the last tube. By releasing the clip about one ounce of solution was allowed to douche the interior of the uterus every hour night and day.

This treatment gave apparently excellent results, and during the last complete year it was used there was only one death from sepsis out of the thirteen deaths from all causes that occurred in the 433 cases of labour that were attended. This result was a very great improvement on all previous years' results, and, considering the large number of infected cases admitted, was very gratifying. The details of the treatment were ably carried out by my house-surgeon, Rai Sahib Shiva Rao M. Trasi, M.B., C.M.

With reference to Dr. Blair Bell's remarks on auto-infection, the only cases I have seen in which I would dare to entertain such a suggestion were two cases of infection in obstetrically normal, clean, unexamined cases suffering from influenza. These occurred during the great influenza epidemic. This disease I soon recognized to have a most grave bearing on the prognosis when occurring in those subject to premature or full-term labour.—I am, etc.,

C. BRODRIBB,

Major I.M.S., late M.O. in charge King Edward's Hospital, Secunderabad, Deccan.

Penmaenmawr, May 20th.

SIR,—Writing on the "prevention of puerperal infection" in your issue of May 28th I notice one of your contributors denounces the use of gloves in midwifery. He gives the following three reasons:

1. "They diminish tactile sensibility." Now if the gloves are a good fit they cannot possibly hinder the perception of such gross anatomical landmarks and relations as the os, bag of membranes, fontanelles, cephalic sutures, prolapsed cord, or the proper engagement or otherwise of any foetal part in the pelvic brim.

2. "The hands are clumsily washed . . . the result is that the left hand still infected presses on the fingers of the right glove and they are fouled." Surely no one would ever dream of touching the fingers of a sterilized glove with a bare hand, however clean. If the glove after being boiled, say in a little bag for the purpose, is emptied into a basin containing a weak solution of lysol—the basin having been previously scrubbed with a boiled nailbrush and scalded out from a kettle—nothing is easier than catching hold of the wrist of the glove with the clean left hand and slipping the right hand in up to the fingers as far as it will go, keeping hand and glove under the surface of the solution. It will be still easier if a washed piece of soap is added to the lysol.

3. "It is considered unnecessary to dip the gloves in an antiseptic." Your correspondent goes on to state that as a consequence any infectious material about the vulva is carried into the vagina without any inhibitor. But how could the momentary contact of an infective organism with perchloride or binioidide of mercury inhibit its growth? And why should the use of gloves prevent anyone from previously cleansing the vulval area? No doubt many cases of sepsis occur where no vaginal examination has been made. But why should this fact make us do away with the use of gloves?

I agree with your correspondent that sterile aprons are dangerous. In a house where there is no help they will not long remain sterile, and are therefore liable to give a false sense of security.

Some time ago a writer in the BRITISH MEDICAL JOURNAL advocated palpation per rectum. I thought I would try this, and was astonished to find how much information can be obtained from this method. As no aseptic ritual is required, it can be done before the patient is washed up. One can always carry a few rubber finger stalls for this purpose to every confinement or threatened abortion. Another of your correspondents fears that an examination per rectum of a patient in labour, as a substitute for the classical "per vaginam," could only result in the instant dismissal of the accoucheur. Fortunately this has not yet been my experience.—I am, etc.,

Leeds, May 28th.

H. T. O'NEILL.

SIR,—From the statements made in your leading article and Dr. Blair Bell's paper published in the BRITISH MEDICAL JOURNAL of May 14th it would appear that the objects of the Midwives Act have not been attained. I have always deplored the folly of medical men in giving away their obstetric practice to the so-called qualified midwife. They ought to conduct as many of these cases as they possibly can and to take a pride in getting the best results possible. The more they attend the greater will be their experience and efficiency, and the greater will be their ability to distinguish between the varying degrees of the normal up to the abnormal pregnancy and confinement. Why the general practitioner should wish to avoid midwifery has always been a mystery to me. I am quite sure it will pay him to give his best attention to these cases, and if he will do so at the confinement, as well as during the puerperium, he will find that the present mortality will be greatly reduced.

Without observing all the minute details of the ritual advocated by some of your correspondents, my mortality from puerperal sepsis has been 0.6 per 1,000 of the 1,500 cases I have conducted—that is, one death, and this happened where the surroundings were much better than the average. I believe the latest mortality rate is 1.76 per 1,000, almost three times the number in my own practice. I have been quite as successful with lysol as with binioidide. One point I observe is not to dry my right hand after thoroughly washing and scrubbing it, and always to rinse it in antiseptic after and before each vaginal examination. Should I need to use my left hand

I rewash and scrub it first. I think it quite possible that infection may be conveyed by wiping one's hands on a clean (?) towel.

The present increasing attendance by midwives at confinements does not seem to decrease the mortality from puerperal sepsis; this object might be attained by every general practitioner making a speciality of obstetrics and not allowing any one but himself to make vaginal examinations where these are necessary. I think it quite likely that, where a certified midwife and a doctor both attend a case, the midwife may have contaminated the patient before the doctor has touched her.

There is something very mysterious about puerperal infection, especially considering the experience given in the letter by "Old Fashioned" in the JOURNAL of May 28th. It is a fact that most of my cases which have required the most manipulation have shown no signs of infection, while other more normal cases have not got on so well. I am, etc.,

Bournemouth, May 30th.

J. M. LOVETT.

SIR,—Like other general practitioners, I have been more amused than wrought by Dr. Blair Bell's address and by your leading article thereupon. Our withers remain unwrung. For myself, it is satisfying to find the views on this subject which I expressed in the BRITISH MEDICAL JOURNAL of December 18th, 1920, so strongly confirmed by the letters in the JOURNAL these last two weeks. In my article I stated that "cases of sepsis will occur . . . in which one will not be able to trace a cause . . . the pursuit of a technique which experience has shown to be adequate is enough." I know, from Dr. Bourne's letter in the following issue, that such a view moves Harley Street, and moves also, apparently, Rodney Street to wrath; but, after all, it is the general practitioner who bears the brunt of midwifery practice, and whose opinion is most likely to be generally accepted. What would old Dr. Hutehinson of Liverpool have said to Dr. Blair Bell's "absolute necessities" after fifty-two years in general practice without a maternal death?—I am, etc.,

Harston, Cambridge, May 31st.

W. J. YOUNG.

SIR,—The prevention of puerperal fever is so vitally important that I may be praised for joining in the present discussion.

It is evident that until the public is further enlightened no practitioner may avoid internal examinations without losing practice. What is chiefly important in internal examinations is the size of the pelvis and the help in diagnosing presentations. Anyway there is no need to put the finger up into the uterine cavity or high in the cervix. The presenting part is felt through the anterior fornix. If no fingers were passed inside the cervix, and if no *post partum* douches were given except under hospital conditions, puerperal sepsis would diminish by half.—I am, etc.,

Wolverhampton, May 31st.

FREDERICK EDGE.

REFRACTION WORK IN SCHOOL CHILDREN.

SIR,—As a refractionist of considerable experience I would like to add a word to the discussion on the relative merits of objective and subjective refraction work. During the last ten years I must have done 30,000 refractions, and I am prepared to maintain that if the objective work be done by the right methods and with sufficient care, in most cases (except myopia) any subjective test, except to find what visual acuity is obtained with the correct glass, is waste of time.

The following method, in most cases, will give the cylinder, with an error less than 0.25 D., frequently less than 0.12 D., and the axis as accurately as the frames will allow it to be read.

Taking a case of compound hypermetropic astigmatism, and using the plane mirror, I first correct the meridian of least hypermetropia with a sphere. Then I put in the frame with this sphere a + cylinder somewhat less than the total amount of the astigmatism. If the astigmatism were 4 D., I would use a + 3 D. cyl. I turn this until the bright band indicative of astigmatism running across the pupil lies directly in the axis of the cylinder. This can be done with great accuracy, and an error of 5 deg. will send the band round through 10 deg. or 15 deg. in the opposite direction. Holding smaller cylinders in

my hand I then neutralize the remaining amount of the astigmatism, and often in doing this I find that I have to alter the lens that at first seemed to correct the meridian of least error.

With the correct glass in front of the eye there should be no trace of astigmatism. Adding -0.5 sph. the shadow should move with, equally in both meridians, and adding $+0.5$ sph. it should be reversed, or with the concave mirror it should still move with. Subtract the reciprocal of the distance at which you work and you have the correction.

In a difficult case I work the whole thing out again using a concave mirror, first correcting with a sphere the meridian of greatest hypermetropia and then the astigmatism with $-$ cylinders. The latter method should give the same prescription as the former, only transposed. If the refracting surfaces of the eye are regular the cylinder is obtained by this method with much greater accuracy than by any subjective method in the average school child. If there be much irregular astigmatism the results are uncertain, but those of subjective testing are equally uncertain in such cases.

I do not profess to get the sphere with the same accuracy, as one frequently finds that different spheres are required to correct the centre and the edge of the pupil. In a highish hypermetrope an error of a fraction of a dioptre in the sphere, provided the error be not over-corrected, is unimportant, but in a myope I like to see what sphere gives the best vision. I consider I can do without difficulty 10 cases in an hour, and more if they are easy ones.

Imperfect mydriasis makes objective testing difficult, but it makes subjective nearly valueless. I have found hyoscine a useful cycloplegic. It should be used in a $\frac{1}{4}$ per cent. solution in castor oil. The alkaloid, not the salt, should be employed, and a good hour should be allowed for its action. In some 10,000 cases I have seen no toxic effects, but have made one child delirious by using a 1 per cent. solution.

Messrs. C. W. Dixey have made me a retinoscopy mirror in which a plane and a suitable concave mirror can be used conveniently with no waste of time.—I am, etc.,

T. W. LETCHWORTH,

Assistant Surgeon, Royal Eye Hospital; Ophthalmic
Surgeon, Tottenham and Surrey Education
Committees.

London, W.1, May 28th.

SIR,—It might be of some value to others to add the experience of one who has worried to some mastery of the subject, though through many personal and admitted mistakes.

There can be little doubt about the best method of prescribing glasses for school children. It falls into three stages:

1. At the first interview the visual acuity of each eye and then both eyes is recorded, and a note made of any external defect. (In a public administrative scheme, especially in country districts, this step can form part of the original routine examination of the child and need not necessarily be made by the oculist.) Arrangements are then made for the application of a mydriatic.

2. At the second interview the eyes are fully under atropine, and the error of refraction is estimated by retinoscopy and any disease of media or fundus noted. The child is told to cease the application of the mydriatic.

3. At the third interview—about two weeks later—a subjective test, based on the retinoscopy finding, is attempted in children over 7 years of age.

Now it is true that in some cases this attempt at subjective testing proves time-wasting, or would prove so if persisted in. It is also admitted that sometimes the retinoscopy findings are given preference in contradiction to the child's statement, as when a vigorous hypermetrope will not accept any plus glass at all. But it is also true that in many cases subjective attempt not only checks one's own possibilities of error, but vastly improves the child's chance of a *comfortable* correction, especially in astigmatic cases, where it can often say whether the cylinder in the trial frame makes the letters "slant sideways" or not.

Again, the individual child's power of accommodation varies and should occasionally be allowed for. A healthy outdoor type of country lad does not always appreciate being relieved of all his ciliary effort. And here I join issue with the dogmatist. Not the objective test alone, nor the subjective, should be the final answer, nor need a full correction be always given, but the considered guidance of all factors should determine the final prescription. To rely on retinoscopy alone, however experienced—and I venture to add, however expert one may become—is in my opinion helping still further to augment the income of the thriving prescribing optician.

But such a two-staged routine takes time and patience, and, from a public administrative point of view, means money. I suspect that in some ophthalmic school schemes no administrative provision is made for the possibility even of a subjective test *after* the effects of the mydriatic have passed away.

This point—the opportunity and the attempt at a subjective test in children—should be an acknowledged necessity, and I agree with the opinions advanced by Dr. A. E. Larking in your issue of May 21st, p. 759.—I am, etc.,

C. ALSTON HUGHES, M.D.,

D.Ch.O.

Liverpool, May 29th.

SIR,—We read with great interest the letter of our old friend Dr. Blease (p. 792), and note that he considers both subjective and objective methods should be employed; that only about three cases an hour should be done, and that the doctor should do the frame fitting himself. We have such confidence in Dr. Blease's skill that one of us has always entrusted his own eyesight to his care, but we doubt whether his practical judgement is in this case worthy of his professional skill. Staffordshire has about the lowest rateable value per child of any county in England; funds are therefore strictly limited; we have approximately 10,000 children requiring refraction, including about 2,000 squints. We fail to see "how the goods can be delivered" on such idealistic lines. In this district the local education authority would discover that the best was the enemy of the good, and that common sense in matters medical was rare, and usually in inverse ratio to the degree of education.

We regret to note from Dr. Larking's letter that any education authority or medical officer of health feels competent to dictate the exact rate at which a responsible official should work. In Staffordshire we only endeavour to impress upon our staff that the problem is how to do most good to a hundred thousand children with one oculist and no immediate prospect of more. In these days of financial crisis we weaken our influence with the public by ignoring the economic side of medical questions. Moreover, it would be interesting to hear the earliest age at which the correspondents use and place value on the subjective tests. We have found it only occasionally of value in children of 12 years, but even in children of 13 years in cases of astigmatism most reliance has to be placed on retinoscopy, and our experience in refraction work is that in most cases a difference of 10 degrees, and sometimes even of 20 degrees, in the axis of a cylinder would not be elicited on testing. How often has one found that even emmetropic children with normal fundi will not read all they see!

If much time is spent over the examination the child becomes tired, and no reliable information is then obtainable; so that to examine only three children in one hour does not necessarily mean that the best results accrue, nor that work more quickly done means work inaccurately done.

By far the greatest number of cases referred to the school oculist are children under 12 years of age, so that he must usually rely solely on the retinoscopy. Hence we agree with Mr. Bishop Harman that subjective tests in school children are of little practical value, and that such refraction work should only be carried out by those who have had the necessary experience to judge what is best to help the child to derive most benefit from education.

Dr. Blease points out—and we agree with him—that no reliance can be placed on complete cycloplegia being obtained from the parents' use of atropine, and hence in Stafford county we arrange for the school nurse to insert the atropine at the clinic or the school.—We are, etc.,

A. G. WILKINS (Senior Medical Inspector) and
JAS. WILLIAMSON (County Oculist) for the County
of Stafford.

May 30th.

THE ORGANIZATION OF SCHOOL OPHTHALMIC WORK.

SIR,—Mr. Bishop Harman's lucid article (BRITISH MEDICAL JOURNAL, May 28th, 1921) on the organization of school ophthalmic work is both interesting and instructive. There is one aspect of school ophthalmic work the importance of which requires to be emphasized—namely, the connexion between school clinics and an eye hospital.

Mr. Harman points out that this is essential in order that difficult cases may be properly dealt with. I should like to remark that this is also necessary from the point of view of the oculist himself. The number and variety of ophthalmoscopic conditions to be seen in a school clinic are very small, retinoscopy occupying a very large proportion of the work. So also the number of external diseases is small, if one excludes chronic blepharitis and phlyctenular conjunctivitis. Again, there are no facilities in the school clinics for operating or seeing operations performed. In order, therefore, that the school oculist may be proficient in the practice of ophthalmology as a whole, he must have a wider field of activity than the school clinic. The school oculist, it seems to me, ought to be allowed to spend two afternoons a week in the clinic of an eye hospital. The most satisfactory arrangement seems to hold where the school oculist devotes his forenoons (two and a half hours for five days a week) to the school clinic, and spends his afternoons at an eye hospital and at private practice.—I am, etc.,

JAMES N. TENNENT,
Ophthalmic Surgeon, Dumbartonshire
Education Authority.

Glasgow, May 30th.

CELL ACTIVITY AND SPECIFIC DRUG ACTION.

SIR,—As a general practitioner I was much interested in Dr. S. E. White's letter on cell activity and specific drug action which appeared in your issue of May 7th. The search for the specific curative drug in any case of disease, acute or chronic, must ever remain the chief aim of applied therapeutics. The suggestion that the selection of a drug by means of a close comparison of all its known and recorded symptoms and effects, with the total symptomatology presented by the diseased patient, is the basis of homeopathy. The homeopathic physician believes that in so administering a drug he is administering a specific stimulus to curative tissue reaction. The letter might well have been written by a homeopath; and I cannot see any material difference between the suggestions put forward by Dr. White and the principles by which homeopaths have selected and do select their drugs.

To my mind a more important consideration is whether such a method of drug selection is possible, practicable, or worth while. It is possible because homeopathy possesses a large and complete "symptom register" pertaining to many drugs. The symptoms so recorded have been elicited by the administration of each drug to large numbers of healthy people who were willing to be subjects of experiment, the drug being "pushed" in many instances till serious and poisonous effects were produced. The symptoms felt and the signs presented by each "prover" were carefully correlated and compared with those presented by other "provers," and symptoms doubtfully due to the drug were eliminated. Clinical use and experience, moreover, have still further established a true symptomatology, while the effects of criminal and accidental poisonings have extended our knowledge of drug effects beyond those possible in a "proving." The net result is that, for the main drugs at least, the "symptom register" is full and genuine.

It is practicable to use this method by carefully taking note of all the symptoms presented by the patient—that is, his total divergence from his own or the commonly accepted normal; and not only those particulars which would lead to a diagnosis of the disease he is suffering from. It is then necessary to compare this record with the already existing symptom registers referred to; and to choose therefrom the drug which most closely corresponds to it. The drug is then administered in a dose which must be sufficient to stimulate reaction but insufficient to add to the sufferings of the patient, who—if the choice of drug be correct—is hypersensitive to it. That it is the tissue reaction which cures, and not the drug directly, is suggested by the fact that a repetition of the dose before the first has exhausted itself is very likely to stop reaction altogether. This method of choosing a drug is obviously laborious and time-consuming to the novice, and frequently enough to the experienced homeopath. The results, however, make it well worth while. At the worst they are as good as the physician could formerly get by using drugs in the ordinary manner; in most cases they are decidedly better, and in some they appear at first as little short of miraculous.

Cases that have resisted ordinary drug treatment can often be satisfactorily dealt with; and even those that one had considered hopeless remain hopeless no longer. All this only if the physician spare neither time nor trouble. There are no short cuts to success, and homoeopathy offers no royal road to the cure of the sick. What it does offer is the means to cure so long as the patient has tissues that are capable of curative reaction.—I am, etc.,

London, N., May 19th.

W. N. BARKER, M.B., Ch.B.

HEART BLOCK.

SIR,—I do not think that a paper such as that of Dr. Wardrop Griffith (May 28th, p. 763) should be allowed to pass without criticism, and especially that part where he says "it is clear that the systolic plateau is dimpled by the drag of the contracting auricle." Is it the function of the auricle to "dimple," and if not, why in this particular case? Did Dr. Griffith take the cardiogram from the patient sitting up or lying down? Was the receiver one inch or three inches in diameter? A reference to my article in the February number of the *Practitioner*, on "The pericardial factor in heart disease," will show that a great deal depends on the position of the patient and the size of the receiver, and that what may be a "dimple" in one position may be something quite different in another.

Apparently no consideration has been given in Dr. Griffith's cases to the quantity and quality of the pericardial fluid present; that they should be taken into account is proved by the fact that when the quantity is in excess, as in pericardial effusion, both waves and "dimples" disappear, whereas in toxic conditions the quality of the pericardial fluid varies with that of the other fluids of the body, and shows itself by an increased number of waves, due probably to a modification of the negative intracardial pressure.

His first case is stated to have died "without any obvious (*sic*) cardiac symptoms": possibly something abdominal was the cause of death; yet, are not the pericardial conditions very often disturbed in abdominal and especially peritonitic affections? The cardiac tracing in Fig. 5 is, in my opinion, one that suggests a toxic condition, and the fact that the heart conditions improved towards the end tends to confirm it.—I am, etc.,

Swansea, May 30th.

G. ARBOUR STEPHENS.

THE "MEDICAL DIRECTORY, 1922."

SIR,—We beg leave to inform you that the annual circular has been posted to every member of the profession. We shall be grateful for its early return to us. If any practitioner fails to receive the form we will, upon request, send him a duplicate.—We are, etc.,

THE EDITORS OF THE "MEDICAL DIRECTORY."

7, Great Marlborough Street, London, W.1,
June 4th.

Obituary.

SAMUEL THOMAS KNAGGS, M.D., F.R.C.S.I.,
Sydney.

WE regret to record the death, on April 13th, of Dr. Samuel Thomas Knaggs, who, until his retirement seven years ago, was one of the leading medical men of New South Wales. He was born in Ireland in 1842, and was brought by his father to Newcastle, Australia, six years later, and there he went to school. He returned to Dublin to study medicine, and in 1870 he obtained the diplomas of L.R.C.P.I. and L.R.C.S.I., passing his Fellowship examination and also graduating in medicine and surgery at Aberdeen University in the following year. In 1873, after he had returned to Australia, he obtained the degree of M.D. Aberd. He became one of the best-known general practitioners in New South Wales, was honorary surgeon to the Newcastle Hospital, joined the New South Wales naval forces, attaining the rank of fleet surgeon, and received the Victorian Decoration. In 1875 he became editor of the *New South Wales Medical Gazette*, which, however, ceased publication six months later. Attracted by medical journalism, Dr. Knaggs two years afterwards started his own medical journal, *The Australian Practitioner*, which was admirably edited and had a considerable effect on the public

health activities of that time in the colony; but the business side was unsuccessful and publication eventually ceased. After twelve years' practice in Newcastle Dr. Knaggs went to Sydney, where he again began in general practice. His reputation had preceded him, however, and he soon became honorary surgeon at the Royal Prince Alfred Hospital, lecturer in clinical surgery at the University of Sydney, and examiner in anatomy and physiology to the Board of Technical Education. Later he accepted the position of medical officer of the Education Department, and afterwards was a member of the Board of Health of New South Wales; he was also appointed honorary surgeon to St. Vincent's Hospital, Sydney. His interests in the affairs of the New South Wales Branch of the British Medical Association dated from the very beginning of the Branch, and in 1886 he was chosen to fill the position of President. In 1895 the Branch acquired by purchase *The Australian Medical Gazette*, which had been established fourteen years before, and the first issue under the new management appeared in January, 1895, with Dr. Knaggs and Dr. L. R. Huxtable as editors. Dr. Huxtable died in July of the same year, and Dr. Knaggs continued as responsible editor until 1901. The six volumes of the *Gazette* during his period as editor stand as unassailable evidence of his ability as a medical journalist. After he relinquished the editorship of the *Gazette* he made a voyage to the East, and practised for some time in Kobe, Japan; on his return to Sydney he practically retired from private practice, and for the last seven years had lived in absolute retirement.

Dr. W. H. Crago writes in *The Medical Journal of Australia*: After an acquaintanceship with the late Dr. S. T. Knaggs, extending over forty-five years, I would like to add my tribute to his memory. Dr. Knaggs was a man of the most genial disposition, large-hearted and generous to a fault. As a friend he was loyal and incapable of doing anything mean. Nothing was too much trouble to him when he could do a kindly act to assist a friend or one in need of help. His advice and practical assistance were readily given to the younger men in the profession. It may truly be said of him that he upheld the best traditions of the profession in doing to others what he would that they should do to him.

ALEXANDER ROSE MACLEAY, M.B., C.M. EDIN.,

Honorary Physician, Bootle Borough Hospital.

DR. ALEXANDER R. MACLEAY died suddenly, from heart failure following operation, on May 29th. Born in Inverness, he graduated at the University of Edinburgh in 1887, and after holding residential appointments at the Infirmary, Inverness, and at the Eye Infirmary, Newcastle-on-Tyne, he settled down in practice in Bootle some thirty years ago. Dr. Macleay had a large practice in Bootle and surrounding district, and was one of the foremost practitioners in the town. Pains-taking and keeping himself thoroughly abreast of the times in scientific medicine, Dr. Macleay was appointed one of the honorary physicians to the Bootle Borough Hospital. His keen interest in his profession precluded him from taking any active part in public life. Yet his interests in everything that pertained to the well-being of the community were very close, and his support, quietly and unostentatiously bestowed, was known to many of his fellow townsmen. His outlook on life and its varied problems was that of a philosopher as well as a medical man. His sudden death came as a shock to many of his friends who were unaware of his illness; of a quiet disposition and somewhat reserved, he disliked to draw attention to himself. Indeed, it may be said that Dr. Macleay went about his daily work doing good, realizing that such a life brought its own reward. It was this characteristic that brought him such genuine affection from rich and poor alike.

The funeral took place at Sefton on June 1st; a large number of mourners, including many medical men, were present to pay a last tribute of affection to the memory of one who had so truly earned the esteem of all with whom he came into contact. He leaves a widow, for whom much sympathy will be felt. The memory of a good and conscientious medical man will remain long in the minds of his patients, who realize how good a friend Dr. Macleay was to them.

SURESH PRASAD SARBADHIKARI, B.A., M.D., C.I.E., Professor of Clinical Surgery, Carmichael Medical College, Calcutta.

DR. SURESH PRASAD SARBADHIKARI, one of the most eminent Indian surgeons, died on March 10th, 1921, in his 55th year. The son of a well known physician of Calcutta, he was educated at the Calcutta Medical College, and graduated M.B. of Calcutta University in 1888, and M.D. two years later. After serving for two years as house-surgeon at the Mayo Hospital, Calcutta, he went into private practice and quickly made a name as a surgeon, being one of the pioneers of ovariectomy in India. He was a vice-president of the first Indian Medical Congress in 1894, and was one of the Indian representatives at the International Medical Congress in London. A member of the Calcutta University Senate, he was a university examiner in surgery, and professor of clinical surgery at the Carmichael College. During the war Dr. Sarbadhikari organized the Bengal Ambulance Corps, which did good work in Mesopotamia; he was awarded the C.I.E., and was appointed an honorary lieutenant-colonel in the I.M.S. He had a large share in the establishment of Carmichael Medical College; he was a member of the British Medical Association, and did much to raise the status of Bengali medical men.

We regret to record the sudden death of Dr. WILLIAM ADAM SMITH MICHIE on May 11th. Dr. Michie, who was 69 years of age, was born at Towie, Aberdeenshire, and received his medical education at Aberdeen University, where he graduated M.B., C.M. in 1879, and M.D. in 1885. He subsequently took the diploma of M.R.C.S. Eng. After practising for some time near Aberdeen, he acquired a large general practice in Blackheath Road, Greenwich, and remained there until 1905. Thereafter he went into practice at 152, Gower Street, where he worked with increasing success until the day of his death. Dr. Michie was an old member of the British Medical Association. His funeral was attended by many patients and by a detachment of the Metropolitan Police, many of whom he attended and with whom he was a great favourite. He is survived by his widow and two married daughters.

Universities and Colleges.

UNIVERSITY OF CAMBRIDGE.

At a congregation held on June 4th C. G. L. Wolf, M.D., received the degree of Ph.D., and the following medical degrees were conferred:

M.D.—C. S. Clarke, L. M. Weeks.
M.B., B.Ch.—H. Barbash, L. W. Batten.
B.Ch.—W. H. Marshall.

Diploma in Psychological Medicine.—The dates for the next examinations have been fixed as follows: For Part I (Anatomy and Physiology of the Nervous System and Psychology), October 11th, 12th, and 13th, 1921; for Part II (Neurology and Psychiatry), November 30th, December 1st and 2nd, 1921. A course of instruction for the Diploma will be held in Cambridge from July 18th to August 20th. Lectures and practical work will be given by Dr. Lowson (Psychology), Dr. Thacker (Anatomy and Physiology of the Nervous System), Dr. Prideaux and Dr. Myers (Psychopathology), Dr. Rivers (Psychology and Pathology of Dreams), Dr. Archdale (Mental Diseases). Those who wish to take the course are requested to send their names, if possible before July 10th, to the Secretary of the D.P.M. Committee, Psychological Laboratory, Cambridge, from whom further particulars may be obtained.

UNIVERSITY OF MANCHESTER.

The following awards have been made:—*Tom Jones Exhibition in Anatomy*: L. J. Prosser. *Turner Medical Prize*: G. V. Ashcroft and Margaret Single.

PROFESSOR ACHARD has been elected general secretary of the Académie de Médecine.

AT Bordeaux a post-graduate course in oto-rhinology will be held, under the direction of Professor Mouré, from July 18th to 30th. The fee is 150 francs, and particulars may be had from the Secretary of the Faculty of Medicine, Place de la Victoire, Bordeaux.

PROFESSOR ALBU, a well known Berlin specialist on diseases of the stomach, died recently at the age of 54.

Medical News.

H.R.H. THE DUKE OF CONNAUGHT will distribute the prizes at St. Thomas's Hospital Medical School on Tuesday, June 21st, at 3 p.m., in the Governors' Hall.

A PROVINCIAL meeting of the Section of Diseases in Children of the Royal Society of Medicine will be held at Reading on June 24th and 25th.

A SYSTEMATIC post-graduate course of instruction in diseases of the heart will be held at the National Hospital for Diseases of the Heart, Westmoreland Street, W.1, from July 11th to July 23rd. Practical instruction will be given in the use of the polygraph, electro-cardiograph and other instruments. Further information can be obtained from the secretary at the hospital.

At the meeting of the Röntgen Society to be held at 35, Russell Square, W.C., on June 16th, at 8.15 p.m., there will be a discussion on the physics of the x-ray tube. All interested are invited to attend.

A DINING club, composed of all past and present members of the honorary and house staffs of the Hospital for Sick Children, Great Ormond Street, held its first dinner, under the chairmanship of Sir Thomas Barlow, on June 1st, when sixty-three members attended, including many who were house officers of the hospital as far back as 1880-1890. It is hoped to hold the next annual dinner on the first Saturday in June, 1922.

THE tournament of the Medical Golfing Society will be held at Walton Heath on Thursday, June 16th. The medical golf championship, for which the *Lancet* has presented a cup, will be played; there will be play also for the Henry Morris challenge cup and the Medical Golfing Society's medal (for the best return under handicap). The annual subscription to the Medical Golfing Society is 5s., which should be paid to the honorary secretary and treasurer, Dr. Rolf Crasay, 36, Weymouth Street, London, W.1. Entries for the competition should be sent to him not later than Tuesday, June 14th.

THE annual dinner of the Indian Medical Service will be held at the Trocadero on Wednesday, June 15th, Major-General Sir R. Havelock Charles, G.C.V.O., in the chair. Tickets and all particulars may be obtained from the joint honorary secretary, Colonel J. J. Pratt, J.M.S.(ret.), 63, Addison Road, Kensington, W.14.

DR. T. G. GARRY, M.B.E. (Cairo), has been reappointed British Physician at Pistany (Pöstyén), Czecho-Slovakia, for the summer months. Pistany has natural hot peat baths which are used for various forms of arthritis, pelvic disorders in women, and cutaneous affections. The place is an hour's journey from Pressburg, the capital of the Czecho-Slovakian Republic. The railway arrangements, it is said, are working satisfactorily.

THE subject of acid-fast bacilli in relation to the prevention and cure of tuberculosis has of late occupied much space in the German medical press. The papers advocating or condemning Friedmann's turtle vaccine have become so numerous that Professor J. Schwalbe, editor of the *Deutsche medizinische Wochenschrift*, announces that to check this deluge he will in future publish only such papers as contribute something definitely new to the subject.

DR. J. H. DOUGLAS WEBSTER, honorary radiologist to the Manchester Ear Hospital, and radiologist to the Manchester Board of Guardians, has been appointed Honorary Physician-in-Charge of the Department of Physical Medicine at the Middlesex Hospital, London.

A MEMORIAL to the medical officers, pharmacists, and members of the Belgian Army Medical Corps who lost their lives in the war was inaugurated by the Minister of National Defence in the Leopold Park, Brussels, on May 29th.

THE annual dinner of the West London Medico-Chirurgical Society was held at the Hotel Great Central on June 2nd, with the President, Dr. Frederick J. McCann, in the chair. After the loyal toasts had been honoured, Mr. Aslett Baldwin proposed "The Imperial Forces," making special mention of the great work done during the war by the medical services. In his reply, Surgeon Vice-Admiral Sir Robert Hill, Medical Director-General R.N., expressed his pleasure at being once again among West London friends. Sir Norman Moore, President of the Royal College of Physicians, in proposing prosperity to the West London Medico-Chirurgical Society, said that his recollection of Charles Keetley, with whose name the society would always be associated, was that of a delightful companion and brave man. Passing from the beginnings of

science at Hammersmith in the days of Prince Rupert, Sir Norman Moore spoke of the origins and functions of the London medical societies, and the benefit that came to them and to medicine through healthy competition. The President, in responding, traced the continued success of the society to the spirit of energy and progress which had animated its officers, among whom the names of Keetley, Bidwell, and Alderton would ever be remembered with honour. The health of "Kindred Societies and Guests" was submitted by Dr. Arthur Saunders and replied to by Dr. G. de B. Tuttle, and the toast of "The Chairman" was proposed in warm terms by Dr. Rickard Lloyd.

MR. NORMAN GODFREY BENNETT, M.A., M.B., L.D.S., and MR. MONTAGUE HOPSON, L.D.S., have been appointed to act as examiners in the entrance examination for the Royal Naval Dental Service.

At a recent meeting of the National Baby Week Council a message from Queen Mary was read by Dr. Eric Fritchard, who was in the chair. The message expressed Her Majesty's interest in the forthcoming celebration in July of the fifth anniversary of the inauguration of Baby Week, and her sincere wishes for the successful continuance of the work. At the same meeting Dr. Mabyn Read, medical officer of health for Worcester, gave some statistics regarding the reduction of the infant mortality rate in that city from 145 per 1,000 births in 1900-4 to 67 per 1,000 in 1920. Dr. Leonard Hill pointed the moral of the smokeless atmosphere of London at the present time, the result of the non-use of coal as fuel, and made a strong appeal for the proper use of coal, in order that the health of the whole community, and not least that of the children, might be benefited. Professor Edgar Collis spoke of economy in health and industrial hygiene. To obtain a healthy nation the first essential was expenditure on healthy infants. Miss Eleanor Rathbone, who pleaded for the endowment of motherhood, pointed out that poverty and privation when the mother was child-bearing and the children were young—had a most serious permanent effect on the health of the race.

At a meeting of the College of Physicians of Philadelphia on May 23rd, Madame Curie presented to the College an apparatus designed and used by her in her earlier research work on measuring the radio-activity of radium, and Dr. Robert Abbe of New York presented mementoes of Lister and of Pasteur in a special case for their permanent preservation.

A HANDSOME presentation was made on June 1st to Dr. J. W. Mullen, Superintendent of the Ladywell Sanatorium, Salford, to mark his completion of forty years' service as medical superintendent of the infectious diseases hospital, and also, by a coincidence, the celebration of his silver wedding. A pupil of the late Sir William Stokes, Dr. Mullen qualified in Dublin in 1877, and immediately afterwards became medical superintendent of the Dublin Small-pox Hospital in the midst of a serious epidemic of that disease. Coming to Salford he devoted his life with great success to the care of patients suffering from infectious diseases.

AN exhibition of x-ray photographs has just been opened at the house of the Royal Photographic Society, 35, Russell Square, W.C., under the auspices of the Röntgen Society. Comprising over 250 prints, it includes a number of notable examples from the French radiologists, which arrived by special aeroplane from Paris on the day before the exhibition opened. Of historic interest are the photographs of hands of celebrities taken in 1896 by Mr. A. Campbell Swinton. There is a series of sets of four prints produced by lay workers employed in the radiographic departments of hospitals, or as assistants to qualified radiographers, shown in competition for prizes offered by Dr. Robert Knox, President of the Röntgen Society. The exhibition will remain open daily during the whole of June, except Sundays, from 11 a.m. to 5 p.m., admission free.

THE second International Congress on the History of Medicine will be held in Paris, from July 1st to 5th, under the auspices of the Société Française d'Histoire de la Médecine, and will be presided over by Professors Jeanselme and Menetrier. The Congress will be opened by the inauguration of the new museum of medical history. The mornings will be occupied by such topics as the history of hospitals and public health work, identification of the great epidemics of history, and the food supply of man and beast in antiquity and the Middle Ages, while in the afternoons excursions will be made to various hospitals, museums, and other places of historical interest in and near Paris. Further details may be obtained from the secretary-general, Dr. Laiguol-Lavastine, 12 bis, place de Laborde, 8^e, Paris.

Letters, Notes, and Answers.

As, owing to printing difficulties, the JOURNAL must be sent to press earlier than hitherto, it is essential that communications intended for the current issue should be received by the first post on Tuesday, and lengthy documents on Monday.

ORIGINAL ARTICLES and LETTERS forwarded for publication are understood to be offered to the BRITISH MEDICAL JOURNAL alone unless the contrary be stated.

CORRESPONDENTS who wish notice to be taken of their communications should authenticate them with their names—of course not necessarily for publication.

AUTHORS desiring reprints of their articles published in the BRITISH MEDICAL JOURNAL are requested to communicate with the Office, 429, Strand, W.C.2, on receipt of proof.

In order to avoid delay, it is particularly requested that ALL letters on the editorial business of the JOURNAL be addressed to the Editor at the Office of the JOURNAL.

The postal address of the BRITISH MEDICAL ASSOCIATION and BRITISH MEDICAL JOURNAL is 429, Strand, London, W.C.2. The telegraphic addresses are:

1. EDITOR of the BRITISH MEDICAL JOURNAL, *Aitiology, Westrand, London*; telephone, 2630, Gerrard.

2. FINANCIAL SECRETARY AND BUSINESS MANAGER (Advertisements, etc.), *Articulate, Westrand, London*; telephone, 2630, Gerrard.

3. MEDICAL SECRETARY, *Medisecra, Westrand, London*; telephone, 2630, Gerrard. The address of the Irish Office of the British Medical Association is 16, South Frederick Street, Dublin (telegrams: *Bacillus, Dublin*; telephone, 4737, Dublin), and of the Scottish Office, 6, Rutland Square, Edinburgh (telegrams: *Associate Edinburgh*; telephone, 4361, Central).

QUERIES AND ANSWERS.

"P. C. G." wishes to ascertain the value, if any, of a work on surgery, in Latin, by Johannes Tagantius, printed at Leyden in 1560, and illustrated with woodcuts.

"WORRIED" writes: Can any of your readers kindly advise me as to the treatment of a case of *Oryzias vermicularis* of three years' duration. Injections of salt and infusion of quassia by means of a long tube have been repeatedly and continuously tried without success.

"M.," as the result of a strain of the right knee some years ago, is now liable, on any slight injury, to suffer aching under the patellar ligament. There is no evidence of rheumatism or known focus of infection. He asks whether it is due to a bursitis or to a "nipping" of the fat and synovial membrane under the ligament, and what is the best treatment?

INCOME TAX.

"C. P." inquires as to liability—if any—in respect of interest accruing in India, but not remitted to this country, on stocks belonging to his wife.

"If neither 'C. P.' nor his wife are ordinarily resident in this country the basis of liability is the amount remitted in the year of assessment; in the alternative liability attaches to the income accruing, whether it is remitted to this country or not. The rate payable is the full, or investment, rate.

"MEDICAL MISSIONARY" states that he receives as a foreign missionary "£260 a year tax free." In making a statement for the purpose of reclaiming a portion of the tax suffered on his private income, he asks how he should calculate the gross income.

"If the Missionary Society is specifically accounting for tax to the British income tax authorities on the stipend the amount to be added to the £260 is the sum paid to the authorities by the society. If, however, our correspondent means that the stipend is "tax free" in the sense that it is exempt from assessment to tax in this country—which seems to be the correct position—he should enter the income as "£260 not liable to taxation."

LETTERS, NOTES, ETC.

DIAPHRAGMATIC HERNIA.

DR. HUGH A. DAVIS, of Wimbledon, writes to say that he was recently called to make a necropsy on a newborn infant. The abdominal cavity contained only the liver, left kidney, bladder, and about one and a half inches of the lower bowel. The other abdominal organs were in the thorax tightly packed against the lungs, which were solid. The opening in the diaphragm was about one and a half inches in diameter.

PSYCHIC PHENOMENA.

DR. J. SCOTT BATTAMS (London, N.W.) writes: In your brief notice of Dr. Crawford's book, *The Psychic Structures of the Goligher Circle*, your reviewer suggests three possible attitudes that may be assumed in regard to this field of inquiry, choosing for himself the most common, and perhaps the least desirable

—namely, the sceptical attitude, with a strong bias towards explaining various phenomena as due to illusion of the senses, as in conjuring tricks. In this attitude of mind many who are now spiritualists began to investigate. It accounts probably for the conclusions reached by those who, without even such first-hand experience, ignore or belittle the remarkable investigations of Dr. Crawford and Dr. Geley. Your reviewer advocates investigation "even of spiritalistic phenomena," but kicks at the precautions and conditions demanded by mediums. But in this obscure field of research the methods of science may suffice, but its most delicate instruments are often useless, and it is impossible to lay down hard and fast conditions. They must be discovered by prolonged investigation and repeated experiment; and the true scientist will not ignore the precautions and conditions adopted by other explorers as the result of experience. To those of us who lack such first-hand experience the question of attitude becomes the more important. I express no opinion as to how far a materialistic science is compatible with any idealistic philosophy or spiritual religion, but it may safely be suggested that scientific men should approach the investigation of "so-called psychic phenomena" with the open mind, remembering that we have not reached that summit where there is no more to learn, but are all evolving. Orthodox psychology knows little of the "make-up" of the medium, and, though it has greatly enlarged our conception of the subconscious, yet to many it is a lumber-room and to others, apparently, a cesspool. Nor should we forget the chastening fact that at every advance in knowledge some of our most cherished theories and dogmas pass into oblivion.

Our Reviewer writes: To Dr. Scott Battams's "attitude" towards other explorers no one need take exception; but his admission that the most delicate instruments of science are often useless in this field of research gives the reason why investigators should refrain from advancing hypothesis of pseudopods and mysterious emanations from the medium. Nearly all writers on the subject of mediums have admitted that the practice of deception has at times been detected. Surely such deception resembles an attempt at producing the illusions of the conjurer, who also demands "precautions and conditions." Therefore any research into the origin of the phenomena demands the attitude of mind adopted with regard to the manipulations of the conjurer, and such words as "materialization" and "pseudopods" should be eliminated from the discussion, unless, indeed, the direct attack has been made on the manifestations by seizing a pseudopod and subjecting it to examination. The allegation that such treatment might seriously damage the medium is given as a reason for imposing some of the conditions. We believe, however, that attempts made in this direction have had no disastrous effects. So long as such crucial tests are not made, the investigator should studiously refrain from suggesting explanations of the phenomena—or illusions—which he describes.

"THE BUFF BOOK."

DR. H. J. VAN PRAAGH (Hampstead, N.W.3) writes: I shall be obliged if you will kindly note that my name appears in "The Buff Book" without my knowledge or consent, and I have written to inform the publishers of their error. I have no idea how it got there, and quite agree with you that it is an unprofessional insertion.

VACANCIES.

NOTIFICATIONS of offices vacant in universities, medical colleges, and of vacant resident and other appointments at hospitals, will be found at pages 25, 26, 27, 30, 31, and 32 of our advertisement columns, and advertisements as to partnerships, assistantships, and locum tenencies at pages 23, 29, and 30.

MESSES. R. AND J. BECK, Ltd. (68, Cornhill, E.C.3), have issued a catalogue describing, with illustrations, special types of the Standard London Microscope. Copies may be obtained on application.

SCALE OF CHARGES FOR ADVERTISEMENTS IN THE BRITISH MEDICAL JOURNAL.

	£	s.	d.
Six lines and under	0	9	0
Each additional line	0	1	6
Whole single column (three columns to page)	7	10	0
Half single column	3	15	0
Half page	10	0	0
Whole page	20	0	0

An average line contains six words.

All remittances by Post Office Orders must be made payable to the British Medical Association at the General Post Office, London. No responsibility will be accepted for any such remittance not so safeguarded.

Advertisements should be delivered, addressed to the Manager, 429, Strand, London, not later than the first post on Tuesday morning preceding publication, and, if not paid for at the time, should be accompanied by a reference.

NOTE.—It is against the rules of the Post Office to receive *posto restante* letters addressed either in initials or numbers.

Remarks

ON

RADIUM THERAPY IN UTERINE CANCER.

BY

A. E. HAYWARD PINCH, F.R.C.S.

MEDICAL SUPERINTENDENT, THE RADIUM INSTITUTION.

OF all diseases to which the female sex is subject carcinoma of the uterus is probably that most productive of constant discomfort, incessant pain, and ever-present mental anguish. To a woman the dreaded diagnosis "cancer of the womb" often appears as the equivalent of a death sentence.

The expectation of life of untreated cases rarely exceeds two years, and in the majority of instances fifteen or eighteen months sees a fatal termination.

Until the introduction of Wertheim's abdominal hysterectomy, surgical measures, if adopted, consisted either of local excision of the diseased cervix, or the performance of vaginal hysterectomy, operations which, in the majority of instances, were followed by speedy recurrence. Wertheim's hysterectomy in skilful hands offers, however, a much better prospect of complete recovery from the disease, but the mortality attendant thereon cannot be lightly regarded, and in many cases when the preliminary laparotomy has been performed an inspection of the pelvic cavity shows that the disease is already too widely disseminated to permit of complete eradication. Other methods tried from time to time, consisting chiefly of the local application of caustic pastes of one kind or another, have little more than a transient palliative effect, the disease returning with renewed vigour so soon as the local reaction has subsided.

Radium has been widely used for the treatment of carcinoma of the uterus, but the results obtained by different workers have varied very greatly. Some claim that radium treatment should be used in all cases in preference to operative measures, whilst others content themselves with saying that whilst it produces very great and definite symptomatic improvement, it never effects a cure of the disease. The truth probably lies somewhere between these two views.

CARCINOMA OF THE CERVIX.

Classification of Cases.

It would serve no useful purpose in a paper of this character to discuss the vexed question as to the microscopical pathology of carcinoma of the cervix uteri, and from the point of view of radium treatment it appears to matter little whether the growth originates in the columnar cells of the mucous membrane of the upper two-thirds of the cervical canal or from the squamous epithelium of the mucosa covering the cervix and the lower third of the cervical canal. In many instances microscopical sections show so much metaplasia of the malignant cells that it is impossible to say from which class of epithelium the growth originated. From the macroscopical appearances, however, it is justifiable to divide these growths clinically into three classes:

1. *The Endocervical or Medullary Type.*—These tumours originate in the mucosa of the cervical canal and form circumscribed nodular growths, unaccompanied by any external ulceration; the predominant early symptoms are an occasional slight uterine haemorrhage and a scanty vaginal discharge. Vaginal examination reveals little more than an enlarged and somewhat indurated cervix. These growths sooner or later break down, ulceration and disintegration rapidly occur, and the cervix is speedily transformed into a crateriform ulcer, with its apex at the internal os; its walls are thin, hard, and extremely friable. This is by far the most malignant type of the disease; lymphatic infection takes place at an early date, and involvement of the base of the bladder, leading to the formation of a vesico-vaginal fistula, is commonly observed.

2. *The Flattened Ulcerated Type.*—This condition in its early stages is often mistaken for a simple erosion, although it is probable that not infrequently a chronic erosion forms a starting point of the malignant process. These growths occur as flattened superficial ulcers, with hard edges, and granular vascular base. They tend to spread widely over the surface of the cervix, and to invade the anterior and posterior fornices. The rate of growth is relatively slow,

and infection of the lymphatics and parametric tissues is not so rapid or extensive as in the case of Group 1.

3. *The Proliferative Fungating Type.*—This class is characterized by the so-called "candleflower" growth, which springs from the extremity of the cervix, forming an irregular, fungating, friable mass which sometimes almost fills the vaginal cavity. This class of growth shows comparatively little tendency to invade the substance of the cervix proper, and is perhaps the least malignant of the three types.

Method of Spread.

The method of spread of the disease has been clearly established, and follows very definite lines. Direct extension occurs by permeation of the lymphatics covering the uterus, of those running through the utero-sacral ligaments, and also, though to a lesser degree, of the lymphatics of the broad ligaments. With this permeation some degree of cellulitis is often associated, so that the peri-uterine induration is generally of a composite character, inflammatory and carcinomatous.

Glandular infection takes place but slowly. As a general rule the iliac groups are the first to be affected, followed later by the sacral glands; as the disease progresses, the lateral lumbar and superficial inguinal glands are attacked. With the associated inflammatory infiltration fixation of the uterus occurs, and there is persistent pain, referred to the lower part of the pelvic cavity: it often radiates into the thighs, and this may be regarded as due to infection of the deeper glands; it is to be looked upon as a strong contraindication to operation.

The symptom which usually first attracts the patient's attention is intermittent uterine haemorrhage, and since the age incidence of the disease corresponds very nearly with that of the menopause, many patients regard the intermittent haemorrhages as being associated with the establishment of the climacteric, and for that reason do not seek a cure until the symptoms of a persistent, copious, offensive vaginal discharge and severe pelvic pain are superadded; thus it happens that too frequently, when a patient submits to examination for the first time, the disease is found to have progressed beyond the reach of surgical measures.

Selection of Cases.

When considering the question of radium therapy, cases should be classified into three groups as follows:

1. *Operable Cases.*—The procedure invariably adopted at the London Radium Institute when a case of early operable carcinoma of the uterus presents itself for examination is strongly to urge immediate operation, followed, when the patient has recovered, by a course of prophylactic irradiation. It is not justifiable to advocate radium treatment in lieu of surgical measures, and for that reason no patient is taken for treatment unless she has positively declined to submit to operation.

2. *Border-line Cases.*—This term is used in reference to that class of case in which the extent of the disease and the amount of infiltration and degree of fixity of the uterus are of such a character that the surgeon is unable to declare positively that the condition is operable; and here it is that radium is often of the greatest use, as by its means much of the existing ulceration is healed, the inflammatory infiltration reduced, and the haemorrhage arrested, so that the removal of the uterus can be more satisfactorily accomplished.

3. *Inoperable Cases.*—In these conditions radium will frequently, almost invariably, produce a degree of symptomatic improvement which is unobtainable by any other methods. Haemorrhage is arrested, discharge diminished, ulceration healed, pain ameliorated, and the progress of the disease checked, sometimes almost completely arrested, the patient's general health being improved in every way.

METHODS OF TREATMENT.

Each case must be judged on its merits, and the procedure varied according to the condition present.

1. *Endocervical Type.*

When dealing with cases of the endocervical type, before much breaking down of the substance of the cervix is apparent, vigorous treatment should be adopted. A tube of 100 to 150 mg. activity, screened with 1 mm. of silver, should be introduced into the cervical canal for twenty-four hours, and this may advantageously be supplemented

by the insertion of tiny emanation tubes of about 25 or 30 mg. activity, screened with 0.3 mm. of platinum, into the nodular infiltration of the cervical walls. Three or four such tubes may be used, according to the amount of infiltration present, and should be allowed to remain in position for periods of twelve hours. A definite reaction ensues, and in favourable cases the resultant fibrosis causes shrinking and hardening of the cervical tissue, compressing the invading acini, and inducing disintegration of the contained cells.

It is advisable, at the same time, to supplement this local treatment by radiation of the whole body of the uterus, and the pelvic cavity generally, and for this purpose powerful applicators, screened with 2 mm. of lead, should be applied externally immediately above the pubes and in both iliac fossae, an exposure of twenty-four hours' duration being given. This radiation serves to arrest or retard the lymphatic permeation and general spread of the disease by direct extension from the cervix to the immediately surrounding parts.

2. Flattened Ulcerated Type.

Where the disease is of a superficial ulcerative character better results are obtained by placing the radium applicators in direct contact with the diseased portions of the cervix; it is in these cases that the use of emanation applicators is to be commended, as it is possible with them to concentrate the activity to a very great degree, and to make the applicator of a size and shape exactly fitted to the area treated.

The tubes may be kept in contact by careful packing with gauze, or still better by the use of dental modelling compound. A mould of the diseased cervix is made, and withdrawn, screened emanation tubes are then embedded in it at those parts which will come into contact with the diseased surfaces, and the mould reinserted. The exposure to be given varies with the strength of the tube and the screening employed, though, as a general rule, with screening of 2 mm. of lead, or its equivalent in some other heavy metal, an exposure of twenty-four hours' duration should suffice.

The same procedure with regard to radiation of the pelvic cavity as indicated in the preceding type should be adopted.

3. The Proliferative Fungating Type.

Here it is advisable, before undertaking treatment, to remove as much of the growth as possible by excision or curetting, and then to treat the remains of the cervical stump. This should be accomplished by the insertion of a 100 mg. tube, screened with 1 mm. of silver, into the cervical canal for twenty-four hours, and the use of tiny platinum screened emanation tubes inserted into any remaining outgrowths that may be present. Here, too, the general radiation of the body of the uterus and pelvic cavity should invariably be adopted.

All patients should afterwards be examined at frequent intervals, and the exposures repeated as and when necessary, though it is advisable not to repeat the treatment at intervals of less than five or six weeks. The vaginal mucosa appears to be much more susceptible than the uterine to radium irradiation, and for this reason it is advisable as far as possible to protect the non-infected vaginal mucous membrane by packing, or the interposition of lead and rubber sheeting. Special attention should be paid to the recto-vaginal septum, as unless this protection be given definite proctitis is sometimes produced in very susceptible subjects. The inflammatory reaction resulting from the treatment described is rarely great, but some degree of vaginitis usually appears about a week or ten days after the exposure, and on this account patients should receive a vaginal douche regularly night and morning for four or five weeks after each exposure, in order to prevent the possible occurrence of adhesive vaginitis.

The amount of symptomatic benefit which the majority of patients experience after the treatment is very striking. Haemorrhage is usually arrested more or less completely within a fortnight of the exposure, the discharge is also greatly diminished, the surrounding infiltration lessened, and the pressure symptoms, such as obstructive constipation, and difficulty or frequency of micturition, much ameliorated. In many cases the pain too is greatly relieved, though when due to pressure of enlarged glands on

nerves of the sacral plexus it is not nearly so frequently benefited.

Ultimate Prognosis.

Many instances are on record amongst the case sheets of the Radium Institute in which patients who have come for treatment at a time when the disease was manifestly inoperable and very extensive, have lived for three, four, or five years from the date of their first treatment, and for the greater part of that period have been free, or almost free, from the more distressing symptoms of their complaint. In some cases the improvement, both local and general, has been so great as to induce the hope that the disease had been completely arrested and the patient apparently cured, but unfortunately sooner or later symptoms have appeared indicative of the infection of parts beyond the effective range of radium, and the disease has slowly progressed to a fatal termination.

Recurrence after Hysterectomy.

Patients suffering from recurrence after hysterectomy often do exceedingly well, more especially if treated within a short time of the appearance of the recurrence. The technique adopted is governed almost entirely by its position and shape. If nodular, and situate at the vaginal vault or on the recto-vaginal septum, the actual insertion of an emanation tube, screened with 1 mm. of silver, for twenty-four hours will often bring about disappearance, and recurrence is not very frequent. When the recurrence is situate on the anterior vaginal wall the proximity of the urethra renders the insertion of a tube into the mass a somewhat hazardous procedure, as it might be followed by the production of a fistula, and for this reason the treatment has to be carried out by means of a leaden screened applicator applied in contact with the vaginal surface of the nodule, supplemented by a smaller silver-screened tube applied within the urethra for two or three hours on four or five successive days. In this way fibrosis of the nodule with encapsulation of the enclosed cells is often obtained, and the risk of a vesico-vaginal fistula obviated.

CARCINOMA OF THE BODY OF THE UTERUS.

This condition is much rarer than carcinoma of the cervix, and comparatively few cases have occurred in the practice of the Radium Institute; the total number has not exceeded 2 per cent. of all the cases of uterine cancer treated. In etiology it differs from that of carcinoma of the cervix in two chief particulars—it is more prone to occur after the establishment of the menopause, and is most generally met with in nulliparae.

Carcinoma of the body of the uterus originates in the cells lining the uterine glands, which proliferate, invade, and destroy the submucous and muscular tissues, and at a late stage of the disease may even perforate the peritoneal covering and infect the abdominal cavity. The onset is very insidious, and diagnosis frequently presents considerable difficulty; but the occurrence of slight persistent uterine haemorrhages, with a more or less uniform enlargement of the body of the uterus in an elderly woman, is always strongly suggestive of malignant disease of the body. The exact diagnosis can, however, often only be established by dilating the cervical canal and removing a portion of the uterine mucosa with a curette for microscopic examination.

Hysterectomy for cancer of the body of the uterus gives more encouraging results than in cancer of the cervix. Dissemination does not take place so rapidly, and is rarely very extensive; fixation of the uterus is a very late feature, and its removal is usually easy; for these reasons the prompt performance of a complete hysterectomy should be urged upon all patients directly the presence of the disease has been clearly established. If, however, the patient positively refuses operation, or has not sought advice until a time when the condition is so far advanced as to be inoperable, then radium treatment should be resorted to.

The routine treatment consists of the introduction of a tube of 150 or 200 mg., screened with 1 mm. of silver, into the uterine cavity, the cervical canal having been previously dilated to a degree sufficient to permit of the passage of a tube with ease. The invasion of the uterine walls by the carcinomatous cells renders them extremely friable, and unless great care is taken in introducing the tube, perforation of the wall may quite easily be produced.

The tube should be maintained in position by light gauze packing, and an exposure of twenty-four hours' duration given, the treatment being repeated after an interval of at least two months.

It is advisable in these cases also to give a general external irradiation to the whole pelvic cavity with powerful applicators screened with 2 mm. of lead applied above the fundus of the uterus and in both iliac fossae.

Recurrences after hysterectomy for carcinoma of the body of the uterus are extremely susceptible to radium therapy, and their disappearance under appropriate dosage may be confidently anticipated.

Prophylactic Irradiation.

Though all workers are in agreement in saying that this procedure is often of great value, great diversity of opinion prevails as to the best method to be adopted.

There are three periods at which prophylactic irradiation may be administered—namely: (1) Five or six weeks before the operation; (2) two or three days before the operation; (3) three or four months after the operation.

(1) *Radiation some five or six weeks before the operation* is of particular use in "border-line" cases with much peri-uterine infiltration of a doubtful character. If properly carried out radiation will often reduce the amount of infiltration very considerably, circumscribing its limits, so rendering them more definitely appreciable, and thus enabling the actual extent of the infection to be more easily estimated. On the other hand, the reduction of the inflammatory infiltration is associated with a certain degree of fibrosis, and this, whilst limiting the spread of the disease, at the same time renders the removal of the uterus a little more difficult, and so lengthens the operation. It is unwise to allow a period exceeding six weeks to elapse between the preliminary irradiation and the operation, for if this time limit be passed the fibrosis becomes very pronounced, and of an almost scirrhous character.

(2) *Prophylactic Irradiation immediately before the Operation.*—This is of great service in cases of the fungating type. As a preliminary to the main operation as much of the cauliflower growth as possible should be removed by cauterizing or excision, and a tube of not less than 150 mg. activity, screened with 1 mm. of silver, introduced into the cervical canal two or three days before the operation; an exposure of twenty-four hours' duration should be given. The irradiation obtained in this fashion will suffice to exert a lethal effect on any disseminated cells in the immediately surrounding tissues or lymphatics, but there will not be time for the development of fibrotic changes, which would serve to impede the performance of the major operation. As most of the radiated tissue will be removed by the surgical procedure, only small isolated foci of the disease will remain, and these the radiation will probably have affected so powerfully as to produce their ultimate degeneration.

(3) *Irradiation Three or Four Months after the Operation.*—This should be done as a routine procedure after all cases of Wertheim's hysterectomy for malignant disease, but considerable caution must be observed in its performance. The elaborate and extensive dissection which is associated with Wertheim's operation appears seriously to impair the functions of the trophic nerves of the pelvis, and it is some time before they return to the normal. Too heavy a dose given at too early a date may result in an excessive reaction, with the production of vesico-vaginal or recto-vaginal fistulae. For these reasons, therefore, it is advisable to limit the intravaginal treatment very considerably, not to treat the case until at least three months have elapsed, and then to use a tube of not more than 50 to 70 mg. activity, screened with 2 mm. of lead and rubber, an exposure not exceeding twenty-four hours' duration being given, preferably in two or three periods of twelve or eight hours each. In this way any intense local reaction is avoided, and the possibilities of fistulous formation abolished. A powerful external irradiation may, however, be given with safety, applicators containing 200 or 300 mg., screened with 2 mm. of lead, being applied externally above the pubes and in both iliac fossae, so as thoroughly to irradiate the whole area. The total exposure in this situation may be of from twenty to thirty hours' duration.

REACTION.

The reaction following on treatment carried out in the manner above indicated is not, as a rule, great or severe. There is a considerable difference in the resisting power of the vaginal and of the uterine tissues; the former are much more susceptible; for this reason it is inadvisable to use silver screening if the apparatus is likely to be in contact with the vaginal mucosa for a period of twenty-four hours, as it is possible that, if the tissues have been infiltrated by carcinomatous cells, considerable destruction, perhaps leading to perforation, may occur; lead screening of at least 2 mm. thickness, with a rubber sheath of 3 mm., should therefore be used whenever the exposure is mainly vaginal in character.

If, on the other hand, the tube is to be completely embedded in the cervical canal, this contingency does not arise, and a screening of 1 mm. of silver only may be employed with impunity.

SYMPTOMS.

As a general rule patients suffer little pain or discomfort after the exposure. In most subjects some slight degree of congestive vaginitis appears in about a week or ten days, and for this reason patients are advised to douche freely night and morning for four or five weeks after the treatment is finished. If this precaution be not observed some degree of adhesive vaginitis may ensue, and the resulting adhesions may have to be forcibly broken down at a later date, causing the patient considerable pain and annoyance.

In extremely susceptible subjects a slight transient proctitis has been noted, but this is very infrequent, and when it does occur it is always of a mild degree, and speedily yields to routine treatment.

In patients who have received repeated exposures at intervals of two or three months for periods of one, two, three, or more years much fibrosis is induced in the vaginal wall, and the associated contraction narrows the canal very greatly, its diameter being reduced to that of a lead pencil, or even less.

In inoperable cases occurring in women who have not passed the menopause external irradiation applied with the object of retarding the general extension of the disease usually suppresses the ovarian functions, leading to amenorrhoea or the premature induction of the climacteric.

In untreated inoperable cases the formation of vesico-vaginal or recto-vaginal fistulae is an almost invariable phenomenon in the later stages of the disease; radium treatment properly administered serves rather to retard the appearance of these fistulae than to hasten their development. An excessive prophylactic dose administered too soon after the performance of Wertheim's hysterectomy may, however, induce a reaction of such degree that much breaking down of the recto-vaginal and vesico-vaginal walls may be induced, and fistulae established; it is for this reason that the precautions previously alluded to when speaking of post-operative prophylactic irradiation should be strictly observed.

GENERAL TREATMENT.

Douching after radium treatment should be carried out as a matter of routine, and is best performed by means of the ordinary douche-can with a soft rubber nozzle; the use of a ball enema syringe should be strictly interdicted. Glycothymoline—one part in twenty of warm water—is soothing and cleansing; lysol, tincture of iodine, and sanitas are also of great value when there is much offensive vaginal discharge; in some cases a weak boracic lotion or solution of potassium permanganate will suffice.

In cases of long standing, where there is pronounced infection of the parametric tissues and the pelvic glands, pain is generally a constant and distressing feature, and it is often difficult to find a means of combating this symptom. Aspirin, phenacetin, pyramidon, and other analgesic synthetic compounds should be freely tried before resorting to the use of opiates, but in many cases a cachet containing 4 grains each of aspirin, phenacetin, and pulv. ipecac. co., administered in a glass of hot milk at bedtime, gives great and immediate relief, and ensures the patient a comfortable night's rest.

As an adjunct to radium treatment, injections of colloidal selenium often prove of considerable use, as they serve to diminish the pain and tenderness, cleanse the ulcerated

surfaces, and cause a decrease in the amount of discharge. The procedure usually adopted is to give a dose of 5 c.cm. intramuscularly every fourth day until six such injections have been given. A further series of six at seven-day intervals is then administered, and a period of one week permitted to elapse, during which the patient receives the radium treatment. The majority of patients tolerate these injections very well, but in a small percentage of cases a definite systemic reaction is observed, patients complaining of pain at the site of injection, with sickness, headache, and a slight rise of temperature; if these symptoms are at all pronounced they must be regarded as a contraindication to the continuance of the treatment.

THE TREATMENT OF ACUTE PYOGENIC INFECTION OF THE KNEE-JOINT.

BY

A. H. SOUTHAM, M.A., M.Ch.Oxon., F.R.C.S.Eng.,
RESIDENT SURGICAL OFFICER, MANCHESTER ROYAL INFIRMARY.

Acute pyogenic infection of the knee-joint may arise as the result of a wound of the joint, by extension of inflammation from a neighbouring focus, or in conditions such as septicaemia and pyaemia where the organisms gain access to the joint from the blood stream.

The treatment recommended in the older textbooks was by making vertical incisions on either side of the patella and inserting drainage tubes into the joint. This was often followed by disastrous results, the infection tracked along the fascial planes up into the thigh and down the calf, where, later, secondary abscesses had to be incised, whilst the patient's general condition steadily deteriorated and amputation had finally to be performed as a life-saving measure.

It is not going too far to say that the presence of a drainage tube in the knee joint almost inevitably ends in disaster. It acts as an open drain for the entrance of secondary organisms from without, and as a foreign body in the joint which serves to keep the inflammatory process active. Further, from a study of the anatomy of the knee-joint, it will be apparent that attempts to drain the joint must be inefficient.

The synovial membrane lining the knee-joint has, like the peritoneum, considerable power for overcoming septic infection when placed under suitable conditions. But it must be remembered that the virulence of organisms is much greater when they are contained, under pressure, in a closed cavity such as the acutely inflamed and swollen knee-joint. For the successful treatment of acute arthritis, therefore, it is necessary to place the synovial membrane under the most favourable conditions, and to lower the intra-articular tension and keep it so reduced without the use of drainage tubes. In mild types of infection this can sometimes be accomplished by aspiration or by incision and lavage, followed by suture of the joint, but in acute pyogenic infection this often fails, the joint fills up again and again, and it becomes obvious from the patient's general condition that something radical must be done.

During the war the treatment of acute suppurative arthritis of the knee furnished one of the most difficult problems of surgery. In the early days it was said¹ that surgeons were impotent to prevent the loss of life or limb in these cases. Later, with improved methods and greater knowledge, better results were obtained, though, in many cases, it was impossible to overcome the infection, and amputation had to be resorted to.

Willems, the Belgian surgeon, suggested treatment² of these cases by active movements on the part of the patient to provide free drainage after incision of the joint. But it is difficult to persuade patients to move an acutely inflamed joint, and I have had little success with this procedure. It is, I think, open to question whether it is advisable to start immediate movement of a joint infected by streptococci in a patient who is already in an acutely toxic condition. As a result of experience gained in the war I have adopted the treatment here described in cases of acute pyogenic infection of the knee-joint, arising from general causes, with satisfactory results. The patients have been left with a useful limb and a movable joint. The number of cases is so limited that I would not presume to draw definite conclusions, yet the method seems worthy of

further trial; it is simple, and the after-treatment and dressings are reduced to a minimum; it has, in my hands, given more satisfactory results than can be obtained by other methods of treatment.

In 7 cases it was successful, the patients having left hospital with movement in the joint which was steadily improving. The last case, one of acute osteomyelitis of the tibia and pyaemic infection of the knee-joint, proved fatal from generalized pyaemic abscesses and pericarditis. *Post-mortem* examination of the knee-joint, two weeks after the operation, showed the joint structures to be healthy, and no pus was present in the joint, the acute condition having completely subsided.

Method of Procedure.

Operation should be immediately carried out when pathological examination of the fluid withdrawn from the joint shows that pus cells and pyogenic organisms are present.

Under general anaesthesia the knee-joint is opened by two lateral incisions, on either side of the patella. These extend from the head of the tibia to the upper limit of the subcutaneous pouch. A tourniquet may be used, or the bleeding points, which are numerous, may be caught in artery forceps; these forceps can be removed later, no ligatures being necessary.

The joint is then thoroughly irrigated with hot saline solution, by means of a Higginson's syringe. Every corner of the joint is explored with the nozzle of the syringe and the knee is flexed and extended to ensure thorough lavage. The irrigation should be continued for ten minutes. The synovial cavity is then dried with lint swabs soaked in ether and held in artery forceps. When this has been completed a small quantity of bipp is applied systematically to the articular surfaces and synovial membrane lining the joint. No sutures are used, the lateral incisions being left open for drainage.

About a dozen turns of broad gauze are then wrapped round the joint, plenty of wool and a firm bandage being applied over this. A strapping extension is fixed to the leg and the limb placed in a Thomas splint, with the knee slightly flexed. The patient is then returned to bed and a light weight applied to the extension.

The temperature usually falls about the third day and the patient's general condition rapidly improves. The dressing is not changed till the fourteenth day, when a fresh one is applied, a little bipp being at the same time rubbed over the lateral incisions. The acute symptoms have usually completely subsided by this time; the splint is now removed and the patient encouraged to move the joint. Massage accompanied by active and passive movements is carried out, and the patient should start walking, when the conditions permit, as early as possible. The dressing is changed about every seven days or as required.

The lateral incisions remain healthy and clean throughout, though it is usually several weeks before they are healed. Probably if secondary suture was adopted this stage might be considerably shortened.

CASE I.

C. D., a miner aged 21 years, was admitted to the Manchester Royal Infirmary on November 3rd, 1920. He stated that whilst working in the mine on October 27th he knocked his right knee against a sharp stone; the knee swelled up and he had been treating it at home. He was found to have a dirty ragged wound on the inner side of the knee, which opened into the joint, from which pus could be expressed. Bacteriological examination showed that streptococci were present. The temperature was 103 F. and the pulse 130.

The knee was treated on the lines described. The temperature fell to normal on the fourth day. When the wounds were dressed on the fourteenth day a small abscess was found in the calf; this was incised. The temperature remained normal throughout, and he was discharged from hospital on January 15th, 1921. The knee could then be flexed to a right angle, the joint was normal in size, and the wounds nearly healed. I have seen the man constantly since; he walks well and has a good range of movement in the knee-joint.

CASE II.

P. A., a butcher, aged 32 years, was admitted to the Royal Infirmary on September 27th, 1920, with a compound comminuted fracture of the right tibia and fibula, the result of a street accident. The wounds became badly infected, and several operations were performed on the leg. His progress was satisfactory till January 8th, when he suddenly had a rigor and the temperature reached 104 F. The rigors continued,

and his knee was then found to be swollen and acutely tender. Pathological examination of the joint fluid showed that pus cells and streptococci were present. The patient was continually asking for the leg to be amputated.

On January 12th it was decided to give the treatment above described a trial. This was carried out, and his condition rapidly improved, the temperature becoming normal on January 16th, and remaining so till his discharge. Several sequestra were subsequently removed from the site of the fracture. The Thomas splint was retained longer than usual owing to the condition of the fracture. He was discharged from hospital on February 24th. The patient now walks with a stick, and can flex his knee to a right angle.

CASE III.

A. R., a boy aged 11 years, was admitted to the Royal Infirmary on January 29th, 1920, with a dirty wound over the left knee-joint, the result of a fall some days earlier. The wound did not appear to communicate with the joint, and he was sent home on February 2nd.

He was readmitted to hospital on February 16th. The knee was painful and swollen, and his temperature was 103.6 F. X-ray examination showed no bony injury. The joint was aspirated on several occasions, and pus cells and staphylococci were found present. As the joint repeatedly filled up and his temperature reached 104 F. the procedure described was adopted. The temperature dropped slowly and his condition rapidly improved. He was discharged on March 24th, the wounds being healed. The knee-joint could be flexed about 45 degrees at that time. I have not seen the boy since that date.

CASE IV.

E. J., a boy aged 16 years, was admitted to the Royal Infirmary on February 3rd, 1921, suffering from acute osteomyelitis of the right tibia. Operation was carried out for this condition the same day, when the medullary cavity of the tibia was freely opened.

His progress continued satisfactory till March 1st, when the right knee-joint was found to be painful and swollen. Aspiration of the joint showed pus cells and streptococci to be present. The joint was therefore opened, washed out, and bipp applied, the limb being placed in a Thomas splint. The right elbow-joint also became involved and was treated on similar lines, lateral incisions being made either side of the olecranon.

A streptococcal vaccine was prepared from the pus by Dr. G. E. Loveday, and injections given at regular intervals. This additional treatment contributed in no small degree to the successful result of the case. His subsequent progress was satisfactory, both joints quickly cleared up, but the wound of the tibia continued discharging pus. He is still receiving hospital treatment for this condition, and massage to the affected joints, which are slowly improving.

CONCLUSIONS.

1. The insertion of drainage tubes into the knee-joint is not only unnecessary, but harmful in acute arthritis. If thorough irrigation with saline is carried out at an early stage, the synovial membrane lining the joint can safely overcome the septic infection aided by the application of bipp.

2. The joint cavity must be left open after the irrigation, otherwise the pus will reaccumulate under pressure, and, burrowing through the capsule, spread in the fascial planes.

3. Extension must be applied to the limb during the early stages to separate the articular surfaces and prevent erosion of the cartilages at the site of pressure.

4. Mobilization and massage must be instituted as soon as the stage of active inflammation has subsided, usually within fourteen days.

REFERENCES.

¹ Gray, *The Early Treatment of War Wounds*. ² *Lancet*, July 10th, 1920, p. 81.

THE RESULTS OF NINETY-EIGHT CASES OF NERVE SUTURE.

BY

PAUL G. DANE, M.D., MELB.

IN the *Medical Journal of Australia*, July 26th, 1919, I reported the results of my observations, extending over two years, on 63 cases of nerve suture, comprising 23 cases of suture of ulnar nerve, 14 of median, 12 of musculo-spiral, 13 of sciatic, and one case of musculo-cutaneous nerve of arm.

This number has been amplified since by the addition of other cases, and the original cases have been revised, so

that 98 cases of nerve suture are now presented, arranged in six series as follows:

1. Ulnar series	35 cases
2. Median series	20 "
3. Musculo-spiral series	15 "
4. Sciatic series	22 "
5. Musculo-cutaneous	1 "
6. Brachial plexus	5 "
				98 "

These cases are entirely unselected—they are taken seriatim from the card records of the Massage Department, No. 5 Australian General Hospital, Melbourne, and all are the result of gunshot wounds, and have been under observation for from twelve to thirty-six months.

The results of operative treatment on these various groups will now be given, and following that a more detailed study of them will be touched upon. On deciding as to recovery I have taken the amount of motor recovery as the standard, it being much more important from a practical standpoint, and much more easy to determine accurately and quickly than sensory return; but as a rule sensory recovery was more complete and earlier than return of motor power.

The groups of cases are divided into four classes: Perfect results; Good; Fair; and Bad results. Under the column "Perfect" are grouped cases that have gone on to full motor and sensory recovery, even though the muscular power be feeble, as it is in a great many cases; under "Good" are found cases where there has been a recovery of muscles subserving gross movements, such as the long flexors in the forearm or the gastrocnemius or tibialis anticus in the leg, but where the muscles subserving finer movements, such as the intrinsic muscles of the hand, have not recovered. In my former paper I also included under this group cases that had a probability of further recovery, but it is hardly necessary to do this now, as the cases have been under observation so much longer. In the group labelled "Fair" are cases that have recovered to a more limited extent, and under "Bad" are cases that have not recovered any function.

Table showing Results in 98 Cases of Nerve Suture.

Nerve.	Perfect.	Good.	Fair.	Bad.	Total.
Ulnar	8	12	3	12	35
Median	5	4	5	6	20
Musculo-spiral	5	3	3	4	15
Sciatic	6	4	2	10	22
Musculo-cutaneous	0	1	0	0	1
Brachial plexus	1	1	2	1	5
Total	25	25	15	33	98
Per cent.	25.5	25.5	15.3	33.6	

By this table it is seen that 25.5 per cent. of the cases have gone on to perfect recovery, whereas 49 per cent. (the last two groups) are practically failures, but if we add together the first two columns as constituting good results we get 51 per cent. of good results as against 49 per cent. of bad results. However, I do not think that we can regard the results purely in this manner, as each individual case must be considered by itself; for instance, in the "Perfect" group of 25 cases only 11 cases regained full motor power—by that I mean regained a perfectly useful limb of the same functional capacity as before the wound; in the majority of cases many of the muscles that regain movement remain weak and atrophic.

The explanation of this fact involves many factors, such as concomitant injury to blood vessels, other nerve trunks, sepsis, and improper pre-operative and post-operative treatment—probably more to this last factor than anything else.

A few of these points are now indicated:

Ulnar Nerve Series.—Sixteen cases had also an injury to the median nerve, and one of these had in addition the musculo-spiral severed. Three of these had also the main artery ligatured.

Median Nerve Series.—Nine of these had the ulnar nerve injured, and one had in addition the musculo-spiral nerve severed; one case had both main arterial trunks ligatured.

Sciatic Nerve Series.—Ten of these were suture of external popliteal and the remainder were cases in which the whole sciatic had been severed. Of the former four gained a perfect result, and of the latter only two gained a perfect result.

Throughout the whole six series of 98 cases the only ones which had had any proper pre-operative or post-operative treatment by means of splints were a few of the musculospiral cases. In the great majority of cases it was not until patients came to our department that any postural treatment was adopted, and in many cases months elapsed between the wound and operation, and between the latter and admission to our department. The results of these six series of cases, aggregating 98 in all, do not agree with some of the glowing reports found in the literature. Professor Tinel in his book estimated that 85 per cent. of his cases had recovered or would recover. He of course acknowledges that all were under the best circumstances for recovery, whatever he means by that. Even taking the most liberal estimate of my cases we find that 51 per cent. represents the standard of recovery, and I feel sure that this figure greatly exceeds the real truth, especially if one regards recovery from the point of functional usefulness apart from mere academic recovery of muscle movement. I have erred on the liberal side in estimating recovery, and do not think that many of the cases (if any) in column "Good" will progress any further.

The results on the whole, then, are in some measure disappointing, considering the tremendous amount of regenerative power that the axis cylinders possess, probably more than any other tissues in the body; and yet the results are encouraging when one considers the many unfavourable factors militating against success in almost every case. Some of these factors have been mentioned above and need not be here reconsidered. The question of the lapse of time between receipt of injury and suture of nerve is very hard to evaluate. Some cases that were operated upon a few hours after being wounded did badly, whereas others which were not operated upon for months did well. Of the operative technique I cannot speak, as cases were done by many different surgeons, but I feel sure that it was good, as the majority were operated upon by surgeons whose ability is well known.

A big factor associated, as I have before stated, with practically every case has been the neglect of pre-operative and post-operative postural treatment by means of splints, etc. This neglect, I feel sure, has been responsible for most of the failures, especially with regard to the delicate intrinsic muscles of the hand. It is not to be expected that these muscles will recover so easily as the other larger muscles. Being situated more distally they are at a marked disadvantage from the point of view, first, of time required for processes to grow into them; secondly, the small size of the nerve trunk as it spreads peripherally renders the march of the new processes more difficult, and these small muscles are pulled out of position very easily by the contracture of antagonistic groups, and this with such delicate organs must greatly injure them.

With regard to post-operative treatment, I have not been much impressed with electrical methods, and in future I shall not employ them at all, or only to a very limited extent. It is impossible to know exactly what one is doing in many cases, and probably more harm than good results from violent shocks to sick muscle engines. Scheft showed in 1851, and Professor Langley confirmed his results (*Journal of Physiology*, July, 1916), that a denervated muscle is in a state of fibrillation. It seems to me that, such being the case, it is the height of absurdity to send comparatively violent electrical stimuli into a muscle in a condition like this. There is one thing above all that it requires, and that is rest—complete rest—and this can only be done by the application of appropriate splints, so as to control all joints over which the muscle acts, thus placing it in a condition of maximum relaxation. This is difficult to obtain fully in many cases, but it is the end to be aimed at, and ingenuity and experience can enable one to design splints, etc., to do this.

Hartman and Blaky, in an extensive research on the subject reported in the *Journal of the American Medical Association*, March 22nd, 1920, performed a series of experiments on rabbits, denervating the muscles of the hind legs, and then applying the recognized forms of treatment. They came to the conclusion that neither massage nor

galvanism had the slightest effect in preventing atrophy of muscles—the only positive conclusion that they came to was that the more perfect the coaptation of the divided nerves the more perfect was the result. They did not try the effect of splinting or postural treatment at all; in fact, they used passive movements daily, which to my mind rather vitiates their results, as, unless these movements are done very carefully, stretching of the sick muscle results and does harm, as W. C. Mackenzie has shown in his work on the paralyses following acute anterior poliomyelitis.

I am convinced that we have as a profession not yet grasped the overwhelming importance of rest—perfect rest—and gradual re-education to muscles that have been injured by denervation from whatever cause. In Australia we should have wakened up to this problem much sooner, as it has been preached to us for the past ten years. It must be emphasized that a denervated muscle is a sick muscle (sick unto death almost), and that we must apply to it the cardinal principle that runs all through our treatment of almost every pathological condition. This applies much more forcibly to such small muscles as the intrinsic muscles of the hand and the muscles of the face, more especially as these are always placed at a great disadvantage by the stretching of the antagonistic groups.

As regards recovery of sensation, my experience has been that this is practically never perfect, but in a great many cases some recovery of sensation returns, and this of itself is of great advantage to the individual, protecting him from burns and other injuries, and also indirectly leading to an increase of nutritional activity.

FIVE CASES OF RAT-BITE FEVER:

TWO CASES TREATED SUCCESSFULLY BY
NOVARSENOBILLON.

BY

F. W. BURTON-FANNING, M.D. CAMB., F.R.C.P.,
HONORARY PHYSICIAN TO THE NORFOLK AND NORWICH HOSPITAL.

Judging from my experience, I am inclined to think that this remarkable disease is not so rare as is generally supposed. It has been well recognized in Japan since 1899, and some 40 cases have been recorded there. But it was not until 1910 that Sir T. J. Horder¹ published an account of three cases of rat-bite fever, stating that they were "instances of a disease hitherto undescribed, at least in this country." Since then single cases have been recorded by Dr. G. S. Middleton,² by Dr. R. W. Crieckshank,³ by Dr. J. O'Carroll,⁴ by Professor R. Tanner Hewlett and Dr. G. H. Rodman,⁵ by Dr. F. Nielsen,⁶ and by Dr. J. H. Nixon.⁷ Dr. A. G. Atkinson⁸ had one case under his own observation, and collected the particulars of 5 other cases, which he published for the first time, together with an excellent account of what is known about this disease.

Since 1897 I have seen five patients suffering from rat-bite fever, all of whom came from different parts of Norfolk. In addition, I have been told of a few other cases, some of which at least were probably instances of the same disease.

Three of my patients were in the Norfolk and Norwich Hospital, one was seen with Dr. G. Calthrop in the Wells Cottage Hospital, and the fifth was seen in consultation with Dr. W. Royden, of Fleggburgh. The cardinal features of the disease were present in all my cases, and are so characteristic that if the existence of such a malady is known its diagnosis is easy. There are also a number of less constant symptoms; these are set out by Dr. Atkinson, and I propose only to refer to some of them and to give briefly the notes of three of my cases. The mortality of rat-bite fever in Japan is stated to be 10 per cent.

The fifteen published cases in Great Britain and my own five cases all eventually recovered. It has been noted as one of the features of the malady, as seen in this country, that there is a tendency to its spontaneous subsidence, but its course may be a very long one and the patients are usually gravely ill. In different cases the duration has varied between a few months and as many years. Until recently it was agreed that no treatment was of any avail. The periodic attacks of fever have led to the trial of large doses of quinine, but this and a number of other drugs—

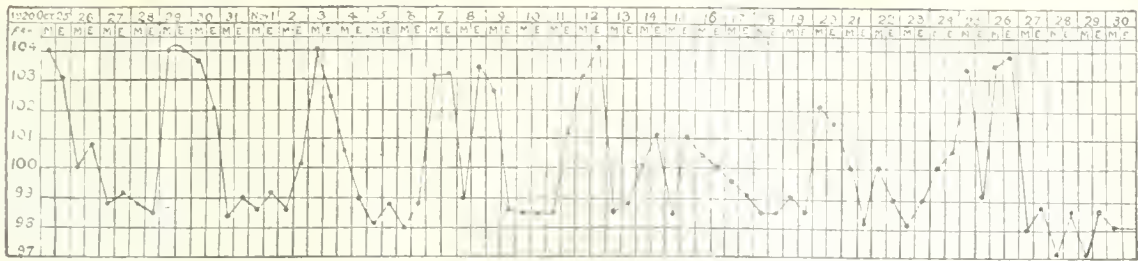

CASE I.—Novarsenobillon 0.45 gram was injected on November 26th.

including atoxyl—have been found useless. Now, however, we have information on the organism which causes the disease, and the last two patients had the benefit of a rational method of treatment which promises to be a cure.

Many different micro-organisms had been found in the past by some observers, and their presence refuted by others. Horder's cases were thoroughly investigated, but with negative results. From two of my patients the blood, and fluid from puncture of inflamed skin in one, have been examined by Dr. G. P. C. Claridge, but he found no organism, and there was no growth on culture media. Other observers have also agreed that there was nothing to be found in the blood or elsewhere.

I am indebted to Dr. Atkinson for having my attention called to a publication by Mr. A. G. R. Foulerton,⁹ describing *Spirochaeta morsus muris*. This organism has been found by Japanese investigators "in the blood of one, out of forty-three apparently healthy house rats examined. Inoculation of a white mouse with the blood of this rat was followed by an infection identical with that produced by inoculation with material from human cases." The negative results obtained by ordinary examination and by culture of the patients' blood are explained, for the demonstration of the spirochaete by direct examination is stated to be difficult. But if white mice are inoculated with the blood, or with exudation from the skin, or with liquid from the affected glands of a human patient suffering from rat-bite fever, the spirochaete can be demonstrated in the mouse's blood. Mr. Foulerton kindly undertook to make some inoculation experiments with the blood of Case III. Six guinea-pigs were inoculated with blood drawn during two bouts of fever, four of the animals have remained quite well, and in none of them have any spirochaetes been detected. Mr. Foulerton writes: "But the clinical evidence leaves no doubt whatever as to the nature of the case, and it appears that others have found the experimental confirmation, by inoculation with patient's blood, somewhat uncertain of result."

Before this spirochaete had been identified as the cause of rat-bite fever its treatment with salvarsan had been advocated by S. Hata.¹⁰ He used salvarsan in eight cases. Five were immediately cured, a sixth case was benefited, and the remaining two cases improved temporarily, but relapsed later. In regard, however, to these last two cases, the author explains that they did not receive a large enough dose. In Case I of mine an intravenous injection of novarsenobillon 0.45 gram was given by Dr. Claridge. As will be seen from the chart an immediate effect was produced, and for the next five weeks the patient had no recurrence of the febrile attacks. Moreover, all the local inflammatory manifestations at once began to clear up, and his general condition to improve markedly. So he returned home to complete his convalescence. Five weeks later it appeared, however, that he was not quite cured. There occurred a rise of temperature to 101.4 and a transient erythema on the limbs. Dr. G. C. Gaynor, under whose care he was at home, gave him a second intravenous injection of novarsenobillon 0.6 gram, and the temperature remained normal for the next seven weeks, while he continued to regain weight and strength and was able to resume work. Two more similar doses were given at intervals of two and three weeks, as the temperature again rose on single occasions to 100, with reappearance of the rash. Three months after his first dose, which was followed by subsequent injections at irregular intervals, the patient appears finally cured and has regained twenty-two pounds of weight.

In Case III the first injection of novarsenobillon was followed by a similar abrupt cessation of fever. Three

more doses were given at regular intervals of a week, but from the time of the first injection he made an uninterrupted recovery as regards every feature of his illness.

If a conclusion may be come to from the experience of these two cases, I would say that a single dose of novarsenobillon puts a stop to the recurring attacks of high fever, and reduces all the inflammatory affections of lymphatics and skin. But, as in the case of *Spirochaeta paluda*, the injection must be repeated at regular intervals of a week to complete the cure.

I will give briefly the notes of three of the patients:

CASE I.

I. H. B., age 154, was admitted into the Norfolk and Norwich Hospital, under my colleague Dr. A. J. Clevehan, who was kind enough to transfer him to me for the purpose of this communication. He had never been ill previously. On October 3rd, 1920, while rat-catching, he was bitten on the left index finger by a ferret which had killed and partly eaten several rats. There were four small punctures on the finger which quickly healed, and never showed at all after the first few days. On October 15th he began to feel ill, and the left axillary glands enlarged. A few days later he was seen by Dr. Gaynor, who noted lymphangitis and lymphadenitis of the left arm, with areas of inflamed skin in other parts, and attacks of fever every few days. On October 25th, on admission to hospital, the patient was obviously very ill; he had a muddy complexion, and was heavy and prostrate. On examination the striking feature was lymphangitis. This could not be traced directly from the bitten finger, but was most marked over both shoulders. Coursing from the tops of each shoulder, over their anterior aspects to the axillae, were three or four parallel red lines. These could be seen and felt to be of about the thickness of the stem of a clinical thermometer. The glands in the right axilla were less enlarged than those in the left axilla, but the lymphangitis was equally marked on the two sides, and less obtrusive affection of the vessels was seen in both arms. Another phenomenon was the occurrence of circular patches of erythema on the forehead, the face, the chest, the upper abdomen, and the forearms. The larger of these were about an inch in diameter; they were red in colour, with a yellowish inner ring. Some were so prominent and swollen as to suggest the presence of pus. With each febrile attack these inflammatory affections of the lymphatics and of the skin would become aggravated and fresh lesions would appear. My patient had a little diarrhoea for a few days, and during each attack of fever he complained also of much soreness and dryness of the throat, where some congestion was apparent.

For the first three weeks of the illness he had epidiidymitis of moderate degree on the left side, which gave him some pain during its existence, but which subsided readily while the other symptoms were at their height. This is a complication which I have not found recorded by others, but it is interesting to read in Foulerton's paper that on *post-mortem* examination of a patient in Japan there was found a single spirochaete in the testicle, while numbers were found in the kidneys and suprarenal glands.

The striking characteristic of rat-bite fever is indicated in the accompanying chart. With almost the punctuality of malaria, every few days the temperature rose sharply, and there was an exacerbation of all symptoms and signs. The fever persisted for from a few hours to a couple of days, and then the temperature became lower and remained so for a certain number of days. The afebrile intervals lasted about three days, and there was a tendency for these to lengthen as the illness went on. In other cases these intervals have extended to a week, but periodicity has been equally marked. This patient's treatment by injections of novarsenobillon has been already referred to.

My first case of rat bite fever occurred in 1897. Its true nature was not recognized at the time, it was diagnosed as ague and was referred to by Professor G. H. F. Nuttall¹¹ as the last case of indigenous ague in England. I am now, however, satisfied, from looking up the excellent

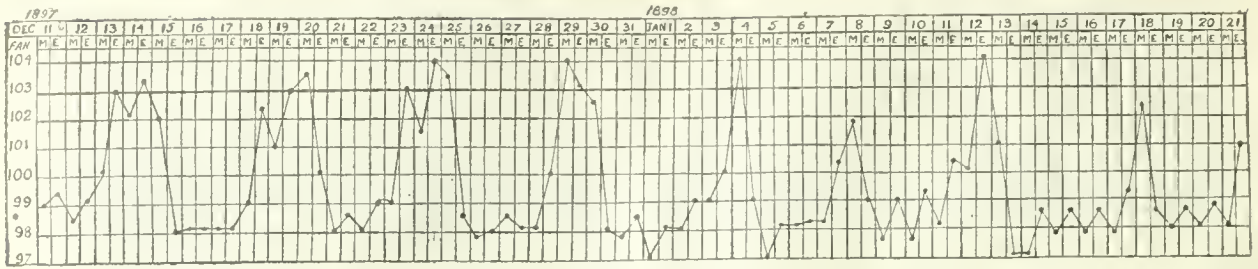

CASE II.

notes of the house-physician, Dr. E. S. Verdon, that in reality it was a case of rat-bite fever in a man who had once been subject to malaria.

CASE II.

W. A., aged 49, was admitted under my care into the Norfolk and Norwich Hospital on December 11th, 1897. He had always lived in Acle, which stands in the centre of a district known for its rivers, broads and marshes, and where *Anopheles maculipennis* is still constantly found. At the age of 10 he had ague, but no mention is made in the notes of recurrence. Nine weeks before coming under my care he had been bitten by a rat in the palm below the right wrist. A local abscess formed, and there was lymphangitis up the arm. An incision had been made, but the skin remained red and indurated. Lymphangitis of the right arm and forearm was the conspicuous condition, but he also had patches of erythema on the other arm. He had paroxysms of fever, shivering and sweating at intervals of from two to four days, along with which it is recorded that the inflammation in the arms increased. Dyspeptic symptoms with frequent vomiting occurred during the whole illness. It was particularly recorded in the notes that quinine in doses up to twenty grains failed to avert the attacks of fever, the last of which occurred fifteen weeks after the bite. Many examinations of his blood were made by Dr. S. H. Long, who at length found a few malarial plasmodia. This finding was confirmed by Professor Nuttall, who saw the slide, which is still in Dr. Long's possession.

In this case there is the history of a rat bite followed after an incubation period by lymphangitis and widespread

surface of the body, of the face, and of the limbs was covered with an extensive papular rash. This was darkish red in colour and with each attack of fever the papules enlarged and fresh ones appeared. The spleen was just palpable and remained slightly enlarged during the illness. On the palmar surface of the right thumb was a sore as large as a florin; this was covered by a yellow slough and surrounded by red skin. There was marked lymphangitis from the thumb up the forearm and the axillary glands on the right side were enlarged and painful.

A blood count showed 11,100 white cells and no eosinophilia. The attacks of fever are represented in the accompanying chart. As these came on the patient complained of severe headache, he felt cold, then followed profuse sweating and occasional vomiting. On one night he was delirious with the fever.

On the evening of the day following his first injection of novarsenobillon the temperature fell, and there was no further recurrence of the attacks of fever, which had previously appeared with more or less regularity every forty-eight hours. Moreover, from this time the rash and the lymphangitis began to fade rapidly and the spleen was no longer palpable. He quickly regained the appearance and feeling of health, and his complete recovery was uninterrupted. I believe that this result was due to his receiving three further doses of novarsenobillon at intervals of a week after his first injection, and without waiting to see if any relapse took place.

In my other two cases the illness was of considerable

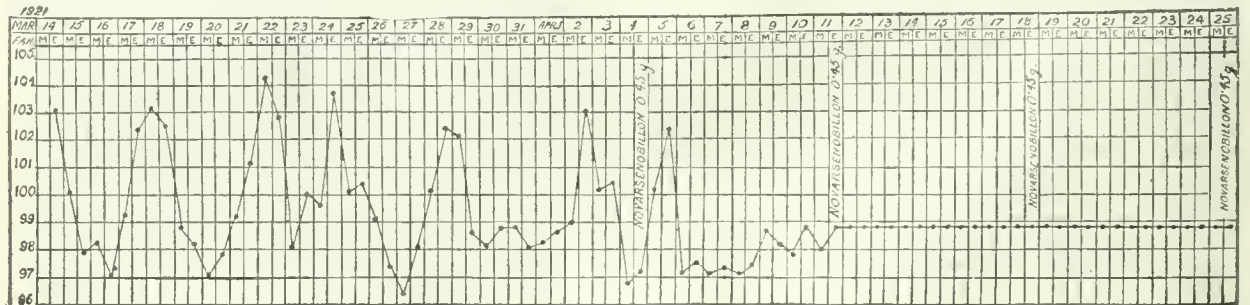

CASE III.

patches of erythema. The paroxysms of fever were not quite punctual in their recurrence and were not controlled by quinine. But the notes quote the patient's statement that they resembled the attacks of ague from which he had definitely suffered thirty-nine years previously and plasmodia were identified by Nuttall and Long. The incidence of rat-bite fever in an old malarial subject, who still harboured the organism of the latter malady, is most remarkable, because the resemblance of the two diseases has been always referred to by writers on rat-bite fever. The temperature chart from the hospital case-book is appended.

CASE III.

S. H., aged 38, was admitted into the Norfolk and Norwich Hospital on March 14th, 1921, under the care of Mr. C. Noon, on account of a septic sore on the thumb with attacks of high fever. I am indebted to Mr. Noon and to his house-surgeon, Mr. P. Murphy, for the following notes and for opportunity to watch the case. The patient was bitten by a rat on February 15th and the small wound on the right thumb healed rapidly under local treatment. About twelve days later there were pain and tenderness at the site of the bite, which increased during the next few days and then extended up the forearm to the axilla. On March 3rd the thumb was incised by his doctor, but no pus was found. Headache, sleeplessness, and slight sore throat, with increasing feverishness, were complained of, and he was sent to the hospital. There he presented the aspect of acute illness, with flushed face and injected conjunctivae. The

severity and was marked by the same type of intermittent fever, extending in one patient over three months and in the other over six months. Two and three weeks elapsed between the bite of the rat and the onset of symptoms. In both patients the wound had healed in the interval, and there was no suppuration. One of the patients had much lymphangitis and lymphadenitis, but the other had only an eruption of boils on the skin. In one of Atkinson's cases the illness was followed by a series of boils.

Without recounting my cases at greater length, I would say that the points of rat-bite fever are as follows: The illness is caused by the bite of a rat, or, as in one of my cases and in one of Atkinson's, by the bite of a ferret, or, as in another of his, by the bite of a kitten—all these animals having just bitten the body of a rat.

There is an incubation period, whose duration in my five cases was from 12 to 21 days, which corresponds with that observed by Atkinson. But the incubation period may extend to two months, as in the cases of Hata and of Hewlett and Rodman. During this period the wound may or may not have healed, and the onset of illness may be associated with fresh inflammation of the wound or of the scar.

Fever of a characteristic type has been the cardinal feature of all cases in this country, though it should be

mentioned that an afebrile form of the disease is described by Japanese writers. There are periodic sharp rises of temperature, which may be accompanied by a rigor. The intervals of normal temperature last three or more days, and the attacks come with some punctuality. With each attack the local inflammations are increased, and there are usually such general symptoms as great malaise, prostration, pains in the limbs, vomiting, diarrhoea, and soreness of the throat.

Swelling of the tongue and definite swellings in different muscles characterized two of Atkinson's cases. The virus of the disease appears particularly to affect the lymphatic system. The constant presence of intense lymphangitis is noted by Japanese writers, and this was the striking feature in four of my cases. It was present in half the cases collected by Atkinson. Enlargement of lymphatic glands has been more common in English cases, though in one of Horder's cases this was absent. Suppuration is often thought to be threatening, but this does not occur except rarely in the wound.

A form of erythema was present in two-thirds of Atkinson's cases and in four of my five cases. Of Horder's three cases it was absent in one, where the only local affection was firm oedema of the bitten arm. In one of my patients the inflamed patches were suggestive of erythema nodosum, but they were more raised, and the only colour effect was the presence of a concentric yellowish ring within the border of the circular red patch.

An Italian case of rat-bite fever, after two years' illness developed retro-ocular cellulitis and exophthalmos. Albuminuria with dropsy has been recorded in several cases; one of my patients had oedema of the feet towards the end of his illness, but there was no albumin in the urine. The occurrence of epididymitis in one of my patients has been mentioned, while in another there was slight but palpable enlargement of the spleen.

Leucocytosis is present as a rule, and increases with each attack of fever. But O'Carroll's case had marked anaemia and a white cell count of 7,200. In this case and in an Italian case eosinophilia was present, though in others its absence is noteworthy. Dr. Claridge's examination of the blood of my patient, I. H. B., gave 23,300 leucocytes with the following differential count: Polymorphs 91.7 per cent., transitionals 1.6 per cent., lymphocytes 5.8 per cent., eosinophils 0.9 per cent.

Rat-bite fever is a serious illness, as testified to by a medical man who himself suffered from it in 1896. He was seen by several eminent doctors, and thought then to have some form of blood poisoning. Dr. G. Master's case is now included in Dr. Atkinson's account of rat-bite fever, and he writes to me:

"I was away from work for seven months and did not feel fit for eighteen months after the start of my illness. The wasting was extreme; I could make my two hands meet round my waist, and at one time I could not turn myself in bed. Treatment did not seem to help in any way."

It now appears that rat-bite fever can be added to the list of diseases for which the cause and the efficient remedy have been found.

REFERENCES.

- ¹Quart. Journ. of Med., 1910. ²Lancet, 1910. ³BRITISH MEDICAL JOURNAL, 1912. ⁴Dublin Journ. of Medical Science, 1912. ⁵Practitioner, 1913. ⁶Practitioner, 1913. ⁷BRITISH MEDICAL JOURNAL, 1914. ⁸Medical Chronicle, 1913. ⁹Journ. Path. and Bact., 1919. ¹⁰Epitome, BRITISH MEDICAL JOURNAL, 1912. ¹¹Journ. of Hygiene, 1901.

THE TREATMENT OF CUTANEOUS ANTHRAX.

BY

W. H. OGILVIE, M.A., M.Ch., F.R.C.S.,

AND

A. W. HALL,

[From the Surgical Department, Guy's Hospital.]

An editorial article in the BRITISH MEDICAL JOURNAL of February 5th, 1921, on the question of anthrax in shaving brushes was concerned mainly with the source of the infected supplies and the methods of dealing with them, but there was a short discussion on means of treatment, in which it was stated that excision of the pustule is no longer recommended. In response to an inquiry the Editor kindly referred us to Circular 172 issued by the

Ministry of Health, January 28th, 1921, from which the following paragraph is quoted:

"Treatment of Persons Infected."

"In general, the best treatment for a case of anthrax is physiological rest of the part affected, combined with intravenous injection of anti-anthrax serum - 60 to 80 c.c.m. on the first day and 60 c.c.m. on the day following, if there has been no reaction (shown by a rise of temperature) and the general condition has not improved. Excision is unnecessary. Subcutaneous injection into the abdominal wall of 30 c.c.m. has apparently been successful in many cases, repeated, if necessary, on successive days. Difficulty is always met with in estimating the efficacy of different methods of treatment of a malady such as anthrax, which is capable of undergoing spontaneous cure. But the following figures, supplied by the medical inspector of factories, with regard to the results of various forms of treatment in 300 cases of cutaneous anthrax (excluding the erysipelalous form) in Great Britain, support the above conclusion:

Treatment.	Cases.	Deaths.	Mortality per cent.
Serum only	200	8	4.0
Excision only	397	44	11.1
Excision and serum	174	25	14.4
No special treatment	29	14	48.3
Total	800	91	11.4

At Guy's Hospital, where a few cases of anthrax are admitted every year, and where the possibility of infection is always present in the minds of those in charge of the surgery owing to the special character of the industries of the borough, the practice for some time past has been to combine excision with serum treatment. It is therefore interesting to compare our figures with those quoted above. We have taken the years 1909 to 1919 because it was only in the year 1910 that serum began to be used regularly. Records for 1918 are unfortunately incomplete. Since 1910 the majority of cases have been treated both by excision and serum, but it is only since 1916 that the serum has been given in doses as large as those recommended in the above circular. In going through the reports all those cases have been omitted where adequate details confirming the diagnosis were absent, or those in which anthrax bacilli were not discovered, though on clinical signs they have been classified as anthrax.

Treatment.	Cases.	Deaths.	Mortality per cent.
Serum only	4	1	25.0
Excision only	6	1	16.6
Excision and serum	37	3	8.1
Treatment not specified	1	1	—
Total	48	6	12.5

The number of cases in this series is obviously far too small to allow conclusions to be drawn from them with any convincing degree of certainty. The gradation of falsehoods into three classes, of which the superlative is "statistics," is a familiar one in political discussion; but it applies with even more force to statistics in medicine or surgery, for the sources of error are innumerable. Successes are nearly all published, very often before they have stood the test of time; failures are as commonly buried in oblivion. Very few series are large enough to exclude the element of chance. But, apart from the factor of the individual and the allowances that must be made for enthusiasm, many other sources of error come in. One is accuracy of diagnosis. Were all cases admitted to Guy's Hospital as anthrax on clinical evidence and not confirmed by discovery of the bacillus to be included, the mortality of the series would be very materially reduced.

This factor of accuracy in diagnosis is especially important in all statistics bearing on the mortality of the surgical treatment of exophthalmic goitre. Another factor is the severity of the type of case which is admitted to any institution. If the death rate from fractures of the base of the skull at different hospitals be examined, it will be found to range from about

CRYPTOGENETIC PNEUMOCOCCAL
SEPTICAEMIA.

BY

SIR JOHN LUMSDEN, K.B.E., M.D.,
PHYSICIAN TO MERCER'S HOSPITAL, DUBLIN.

50 per cent. in some places to 10 per cent. in others. This discrepancy is merely due to the fact that the first hospital is in the centre of an industrial district where severe accidents are common, the second in a scattered neighbourhood with poor facilities for transport, so that most severe head injuries die before reaching hospital. In fracture of the base it is the severity of the injury and not the line of treatment adopted which is the chief factor in determining the result. For this reason the comparison of statistics published by different surgeons during the war is valueless unless the exact conditions are known. The mortality in gunshot wounds of the abdomen, for instance, might be expected to be small at a base hospital, much greater at a casualty clearing station, and still greater at an advanced centre, merely because distance automatically sorted out the severe cases.

If we examine critically the figures quoted from the circular of the Ministry of Health, it is difficult to agree with the conclusion that excision is unnecessary. The very fact that the mortality after excision, *plus* serum, is greater than that for either serum alone or excision alone, shows that other factors are at work. Were excision a harmful factor (as it might be, owing to disturbance of the protective barrier set up by the tissues), the mortality of the cases treated by excision alone should be greater than that of the untreated cases. But, leaving this argument on one side, it is absolutely certain that, were excision harmful, the cases treated by excision only should do worse than those treated by excision *plus* serum. It is unthinkable that a harmful factor should be less harmful by itself than when combined with a beneficent factor. If, then, excision is not harmful, it may be either a valuable or a neutral factor in treatment. The facts that stand out from the report are, first, that over 70 per cent. of the 800 cases have been treated by excision, which seems to point to a fairly general belief in the efficacy of this procedure; and, secondly, that excision by itself has reduced a death rate of 48.3 per cent. to one of 11.1 per cent. without the use of serum in addition. It seems pretty certain that the mortality given for the cases in which both methods were employed involves other questions in addition to that of the treatment adopted. We suggest that the cases treated by serum only would probably include all very slight cases, and all doubtful pustules in leather workers which resembled anthrax lesions but were not proved to be so, or did not seem severe enough to justify excision. In such cases it would be only right, in view of the danger, to give a prophylactic dose of serum. Late cases of genuine anthrax in which a natural cure was being effected would probably also be treated with serum only. On the other hand, extensive lesions of a fulminating type would nearly all come into the class treated by both methods.

It is probable that the series from Guy's Hospital, though small, gives a much fairer picture, and that the death rate when both methods are combined is notably lower than when either is used alone. In the early stages of anthrax the bacilli are limited to the pustule and its immediate neighbourhood. Excision by itself will assure a cure in about 90 per cent. of cases in a disease having a natural mortality of something like 50 per cent., while serum at best cannot be relied upon to avoid a fatal issue in all cases. In view of the danger of anthrax and the local nature of the infection in the early stages, it therefore appears to us to be the wiser course to combine the two methods, which are both known to be good and which cannot be mutually antagonistic, and thus to give the patient every chance. Little or no importance can in the circumstances be attached to the resulting scar. We consider, then, that the combination of excision and serum treatment as used at Guy's Hospital is probably the most rational and the safest course in all cases of cutaneous anthrax which have not reached the stage of a septicaemia.

CRYPTOGENETIC SEPTICAEMIAS are of particular interest to the physician, and, as a search of the literature on the subject shows few cases recorded of pneumococcal septicaemia without any evidence of a focal lesion or portal of entry, the following brief notes of a case recently under my care is, I think, of sufficient interest to record. That a blood infection occurs in acute pneumonia in a large percentage of cases, and that the pneumococcus can be cultured from the blood in many cases has been demonstrated in an extensive series of investigations. It has been stated by one observer that blood cultures give positive results in 50 per cent. of fatal cases; others have suggested invasion of the blood by pneumococcus to be a constant condition. Pneumococcaemia, however, without distinct localizations, has, Osler states, been reported by Wright, Stokes, Pearce, Flexner, Hektoen, and others. The following case would, therefore, seem to be of the cryptogenetic variety.

Mrs. S., aged 48, came to see me about March 8th, 1921. Her symptoms were of an indefinite character. For some weeks she had been feeling unwell, had been losing energy and some weight, appetite was poor, and she suffered from restless nights, shivering fits, occasional diarrhoea, and persistent polyuria. The temperature was normal and the pulse small and of low tension. A hasty examination of chest and abdomen failed to elicit any definite abnormality. She had no cough or any symptoms referable to her chest. She complained of lumbar pain radiating down the back of the thighs, and also some nausea. There was a history of slight discharge from the left ear, lasting a few days, some short time before, but it apparently cleared up, and at present no otitis media was evident. I examined the urine next day—specific gravity 1016, somewhat turbid, no sugar, a trace of albumin. As her family were becoming increasingly anxious on account of her lack of energy, progressive weakness, and shivering attacks, I was asked to admit her to Mercer's Hospital on March 22nd, 1921.

Condition on Admission.

General aspect: Face yellowish, cheeks flushed, eyes bright. Tongue perfectly clean, gums and throat healthy. Although thin, no marked emaciation. Pulse 100, regular. Blood pressure: systolic 90 mm. of mercury; diastolic 65 mm. of mercury. Temperature normal. Abdomen slightly distended, some relative rigidity below liver, and marked tenderness in both loins. Neither kidney was to be felt, but lower pole of spleen palpable. Reflexes normal. Urine: specific gravity 1020, acid, no sugar, slight amount of albumin; microscopically, some pus and epithelial cells, no casts, a number of mobile organisms, probably *B. coli*.

After-History.

During the following week her condition remained unchanged. She appeared apathetic, had no desire for food, had some nausea, was slightly constipated, and sleep was restless. Her temperature ran up to 101° at night, but returned to normal in the morning. On March 29th she had a distinct rigor. The temperature was 103°, and pulse rate 124. Blood examination showed red cells 4,500,000, haemoglobin 85 per cent., white cells, 8,000. Rectal and vaginal examination were negative.

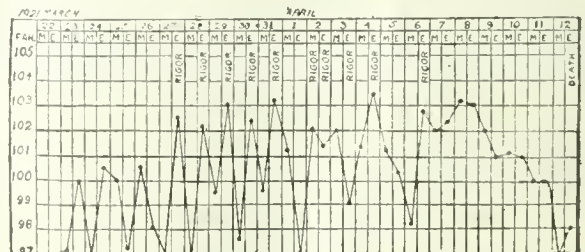

During the second week in hospital the temperature became remittent, she had recurrent rigors, the temperature reaching 103°, and the pulse ranged between 88 and 128. I noticed a slight roughening of the first sound at the apex, and the rhythm became of a gallop type due to reduplication of the first sound, I thought, or possibly pericarditis. Tenderness and pain continued in the loins, and this was the chief complaint from the patient. There was no cough nor any abnormal lung sounds, although at the end of the second week some rhonchi and râles appeared, clearly due to a congestion or oedema. Petchiae appeared on the left breast, arms, gums, and the inside of the cheeks. She had fairly good sleep with the aid of bromidia.

The Journal of the American Medical Association announces that Brigadier-General Charles E. Sawyer, personal physician to President Harding, has been assigned a suite of rooms in the State, War, and Navy Building, formerly occupied as headquarters of the Army, from which he will direct the establishment of a department for the arrangement of better hospital facilities for disabled soldiers and sailors.

Although the results of the first blood culture showed a bacteraemia it was not until the second examination that our pathologist, Dr. Pollock, satisfied himself that there was a pneumococcaemia. During the last week of the patient's illness she became wildly delirious, the sphincters became relaxed, and a slight systolic murmur was audible. She passed into a "typhoid state," and died at the end of the third week in the hospital, the temperature falling gradually to normal and blood pressure remaining persistently low.

Pathological Notes.

The following notes on the examination of the blood and on the *post-mortem* findings are by Dr. Pollock:

"As is my usual practice in blood culture, I withdrew 5 c.cm. of blood from a vein at the bend of the left elbow by means of a serum syringe, discharging the whole blood direct into a flask containing 50 c.cm. nutrient broth. I have found this method preferable to direct plating, as in the latter only a comparatively small amount of blood can be employed, and if the degree of infection be slight failure to cultivate may result. Unfortunately, the first flask became contaminated, and the second attempt was made a day or two subsequently. In this a practically pure culture was obtained of a Gram-positive coccus in pairs and chains, these latter being, in some instances, of such length as to suggest streptococci. Subsequent plate cultivation, however, reduced the chains, when present, to the short, straight diplococci pairs characteristic of pneumococci; the vast majority of organisms, however, being diplococcal in arrangement and, in my opinion, of characteristic morphology. The numerous organisms present in the sections made subsequently from the thrombi present in the right auricle, *post-mortem*, were seen in pairs, characteristically lancet-shaped, and were, in my opinion, characteristic pneumococci. The tendency of this organism in rich liquid media to approximate to a streptococcal type is, I think, noteworthy, being particularly noticeable during the somewhat recent severe epidemics of septic pneumonia."

The results of the *post-mortem* examination were as follows:

Thorax.—Pleura normal, no fluid in cavity.
Lungs.—Some slight emphysema present; oedema of both bases; no pneumococcal consolidation whatever.
Pericardium.—Distended with a clear yellow fluid (about 6 oz.); subepicardial petechiae, most marked over right auricle.
Heart.—Myocardium showed marked fatty infiltration, endocardium some relative mitral incompetence. Both aspects of tricuspid valve were covered with immense adherent vegetations. Growing from this evidently diseased valve up into the cavity of the right auricle, and almost entirely filling it, was a great *ante-mortem* thrombus of a peculiar greenish tint. Miliary vegetations were also present upon the endocardium lining the right auricle.
Abdomen.—Liver: early "nutmeg" condition. Spleen: large, soft, pulpy, with petechial haemorrhages. Kidneys: both showed an early chronic nephritis, more marked in the right. No suppurative condition. Other viscera apparently normal, and general condition of body good.

Memoranda:

MEDICAL, SURGICAL, OBSTETRICAL.

HERPES AND VARICELLA.

THE interest at present shown in the relation between herpes and varicella leads me to send notes of a recent well marked case.

A woman, aged 53 years, was taken ill on April 8th, 1921, with pain low down on the right side of the chest and a feeling of general illness. When seen on the afternoon of April 11th a patch of herpetic vesicles was present; it developed, and ultimately a severe rash occupied the fifth and sixth right dorsal root areas. At first no eruption was to be seen elsewhere, but on April 14th there were two dozen macules, papules, and vesicles scattered over the trunk, shoulders, and buttocks. Three days later a vesicular eruption was present over the whole body, including the face; more than 100 vesicles were counted. The whole cleared away gradually, but severe pain persisted in the area of the "herpetic" rash.

GEORGE E. ELKINGTON, M.B. Lond., F.R.C.S.

Newport Shropshire.

A CASE OF MYOCLONIC EPIDEMIC ENCEPHALITIS.

THE case reported below occurred during the recent small outbreak of epidemic encephalitis in the city of Bristol, and was the only one that could definitely be classified as of the myoclonic type. The remainder of the cases seen, numbering between 20 and 30, were of the common cranial nerve palsy, lethargic type.

G. L., aged 32, began to suffer from acute abdominal pain, without vomiting, on September 16th, 1920; next day he had diplopia, twitchings and spasmodic movements of the body and limbs, and the pain was worse.

He was admitted to the Bristol General Hospital on September 19th as an "acute abdomen." The temperature was 102°, the pulse 100, and the respirations 32. The tongue was coated. The eyes were prominent and bloodshot; the pupils were equal and reacted normally; there was marked nystagmus and left external strabismus. Speech was blurred with a tendency to stammer; he had never stammered before. There was no facial weakness. Spasmodic movements of arms and abdomen were frequent; all the abdominal muscles were involved and the movements were at times rhythmic and 20 to 30 to the minute. There was true abdominal rigidity; the knee jerks were very active.

The spasms ceased on September 20th. The patient, who was somewhat delirious, complained of abdominal pain. The leucocyte count was 15,500. The cerebro-spinal fluid was sterile; the number of cells was not increased, and there was a slight excess of globulin.

On September 23rd he was still boisterous and delirious; the right pupil was larger than the left, and there was facial paralysis on the right side and incontinence of urine. On September 25th he was much better, the temperature was normal, and he was quite rational; the right side of the face was still weak. On September 27th the temperature rose to 99.8 and he relapsed into delirium; no fresh paralysis developed. He died in coma on September 28th.

Post-mortem Examination.

There was some congestion, oedema and softening of the brain, and microscopic sections stained by methylene blue and eosin showed the following changes: In the cerebral cortex there were a few small haemorrhages into the pia mater, and a few of the nerve cells showed neuronophagia. The invading cells were basophil and considerably larger than the small round cells seen infiltrating the mid-brain areas.

In the mid-brain, at the level of the inferior geniculate body, general round-celled infiltration and perivascular infiltration was very dense, notably at the point of exit of the optic nerve. Some of the nerve cells were densely crowded with pigment granules. At the level of the nucleus of the third nerve and superior corpora quadrigemina, round-celled infiltration was present in moderate degree; perivascular infiltration was dense in parts, and some of the blood vessels were thrombosed. In sections through the reticular perivascular infiltration was fairly marked, but there was much less round-celled infiltration. The nerve cells generally appeared degenerate.

In the pons at the middle of the fourth ventricle the same lesions were present in less degree. Several vessels were thrombosed, and neuronophagia was present. The upper half of the olivary nucleus in the median oblongata showed very little abnormality, and in sections of the spinal cord no macroscopic or microscopic lesions were noted.

Compared with sections from other cases of epidemic encephalitis (cranial nerve palsy type) those described here show no lesion or distribution of lesions, at present recognizable by the means employed, that accounts for the variation in symptomatology. I am indebted to Drs. J. Odery Symes and Cecil Clarke for permission to publish these notes.

E. J. BRADLEY, M.D., B.Ch. (Camb.).

Late Scaler R.M.O. Bristol General Hospital.

THE ACTION OF QUININE ON PREGNANT AND NON-PREGNANT UTERUS IN THE TROPICS.

IN tropical countries some medical practitioners advise pregnant women to give prophylactic doses of quinine as soon as pregnancy begins. The result is in many cases that chronic malaria causes severe anaemia and abortions; should the mother go to full term the children are badly nourished and have to be artificially fed owing to the poverty of the mother's milk, and unless both are removed from tropical regions there is great danger of the loss of their lives.

As with some women 5 grains of quinine cause contractions of the pregnant uterus and sometimes haemorrhage, I advise that the 5-grain prophylactic dose be taken in two doses of 2½ grains morning and evening, and in my thirty-two years' experience in Central Africa (11th deg. S. lat.) I have never seen a case where this has done any harm, and in nearly every case the 5 grains has kept the

women free from active malaria until the confinement. Then as the vital powers of resisting disease are much lowered by the excessive fatigue of child-bearing, it is necessary to give 10 grains (in very small doses) a day for five or six days, as very often, if not given, a severe attack of malaria will delay recovery with these doses.

I have never found quinine cause abortion. On the other hand, I have treated cases of abortion in native women (who do not take quinine), in which the frequent abortions were undoubtedly caused by chronic malaria, for when given the above prophylactic doses they were able to go to term and give birth to healthy living children.

With regard to the effect of quinine on the non-pregnant uterus, undoubtedly in a small percentage of cases it causes excessive and too frequent periods. Years ago I found that when 5-grain doses of quinine caused deafness or noises in the ears it was a sign that a smaller dose (3 grains) was sufficient as a prophylactic, and the majority of women under 120 lb. weight will, I think, find this smaller dose will keep them free from active malarial manifestations.

Recently I have treated this menorrhagia also as a sign that only smaller doses of quinine need be taken, and if the 5-grain prophylactic dose is necessary it should be taken in 2½-grain doses twice a day; the few cases treated, however, are not sufficient to lead me to any definite conclusions, and I would value greatly the experience of others in treating this very trying complaint.

WALTER FISHER, M.R.C.S., L.R.C.P.

Kalene Hill, Northern Rhodesia.

Reports of Societies.

THE END-RESULTS OF PLASTIC VAGINAL OPERATIONS FOR GENITAL PROLAPSE.

THE first British Congress of Obstetrics and Gynaecology was held at Birmingham on June 3rd and 4th, when the following societies were represented: the Obstetrical and Gynaecological Section, Royal Society of Medicine; the Edinburgh Obstetrical Society; the North of England Obstetrical and Gynaecological Society; the Glasgow Obstetrical Society; and the Midland Obstetrical and Gynaecological Society.

The opening session in the morning of June 3rd was presided over by Professor H. BRIGGS, President of the Obstetrical and Gynaecological Section of the Royal Society of Medicine. Mr. CHRISTOPHER MARTIN, chairman of the Midland Obstetrical and Gynaecological Society, welcomed the Congress to Birmingham, and expressed the hope, which was echoed by various speakers throughout the day, that this Congress would now become an annual affair, and the chief and authoritative mouthpiece of British gynaecology.

The morning session was devoted to a discussion upon the operative treatment of genital prolapse, opened by Dr. W. E. FOTHERGILL and Dr. F. H. LACEY, of Manchester. The title of their paper was "The End-Results of Plastic Vaginal Operations for Genital Prolapse."

Dr. W. E. FOTHERGILL said that the discussion had originated at a meeting of the North of England Society held at Liverpool in December, 1918. Professor H. Briggs had described the treatment of a case of proclitica, in a patient aged 18, by a vaginal operation combined with ventrofixation, but advocated a modification of Gilliam's operation. Dr. W. F. Shaw deprecated abdominal operations for prolapse, preferring the vaginal methods used in Manchester. Other members urged that the end-results of these measures should be ascertained and published and a collective investigation by the society was suggested. At subsequent meetings this project was developed and the scope of the inquiry came in question. It was proposed to exclude all except cases of complete prolapse, but this was not thought feasible. The term "genital prolapse" had a fairly definite connotation all over the world; and medical men constantly used the word "prolapse" as including both so-called vagino-uterine prolapse and so-called utero-vaginal prolapse. In view of these considerations, it was decided at a Council meeting of the North of England Society in December, 1919, that the inquiry should include "cases of (1) cystocele, (2) rectocele, (3) prolapsus uteri, and (4) elongated cervix protruding from

the vulva"—namely, in two words, cases of "genital prolapse." At an ordinary meeting of the society in Liverpool in October, 1920, Dr. F. H. Lacey gave a preliminary report on traced cases operated on at St. Mary's Hospital, Manchester, during the years 1914-15-16. Subsequently it was arranged to defer the further consideration of the subject to this meeting.

Dr. Fothergill briefly indicated the steps by which he was led to his present technique, starting with his work in Edinburgh under Sir A. R. Simpson and David Berry Hart, who used at that time anterior and posterior colporrhaphies of moderate size, amputation of the cervix, and repair of the perineum. These were done as separate operations, and in some cases all four were used for one patient. Chronic catgut was the suture material, and the immediate results were good. On coming to Manchester in 1895 he found that, owing to the initiative of Professor A. Donald, surgical treatment of genital prolapse was already highly efficient; anterior colporrhaphy incisions were larger than those done in Edinburgh, and the whole thickness of the vaginal wall was removed. Donald had also combined the operation of posterior colporrhaphy with perineorrhaphy in a single operation done from above downwards.

Dr. Fothergill was gradually convinced by clinical experience that the uterus, vagina, and bladder were mainly kept in position by the lateral combinations of unstriated muscle and connective tissue known as the parametrium and the paracolpos, and this was demonstrated by him to the Royal Society of Medicine in 1907. The practical application was that anterior colporrhaphy could be improved by carrying the incision well up and out on either side of the cervix, fully exposing the paracolpos, so that closure of the wound must bring together in front of the cervix structures formerly at its sides. This he demonstrated to the Edinburgh Obstetrical Society in 1908. Subsequently he found that by carrying the incision round behind the cervix instead of in front of it, anterior colporrhaphy and amputation of the cervix could be conveniently combined in one single operation. When the wound was closed the cervical stump passed upwards and backwards so far that the uterus was left in a position of anteversion, thus dispensing with the need of excessive narrowing of the vagina. An improved technique and modifications were afterwards described in the *BRITISH MEDICAL JOURNAL* (April 12th, 1913); the *American Journal of Surgery* (May, 1915); and in the *Journal of Obstetrics and Gynaecology of the British Empire* (March and May, 1915). Dr. Lacey had traced as far as possible the after-histories of the cases treated by Dr. Fothergill at St. Mary's in 1914-15-16, so that since these operations were done periods varying from four and a half to seven and a half years had elapsed; no cases treated by mere perineal repair were included. One hundred and fifty-six patients replied to Dr. Lacey's letter of inquiry; of these, 150 stated without qualification that they were cured, while 6 did not. Of these 6, No. 1 had had three children since the operation, and the womb has gone down again; No. 2 said the "womb was not as it should be," but on examination no prolapse nor other abnormality was found; No. 3 had chronic bronchitis and asthma, and the operation was therefore a failure from the start; in No. 4 the uterus was in good position, but there was some vaginal prolapse; No. 5, a case of rectocele only, had an instrumental labour and was torn badly, and there was a slight recurrence of rectocele; and in No. 6 nothing was found on examination, but she said she still had pain at times. This gave 97½ per cent. of cures. As to the ages of the patients, about one-third had passed the menopause.

In 124 cases combined amputation of the cervix with anterior colporrhaphy was done, while in the remainder the cervix was retained. Thirty-two were examples of elongated cervix with inversion of the vaginal walls from above downwards. It would be unreasonable to expect that the new pelvic floor should always stand the test of labour; the original pelvic floor did not always do so. From this point of view it was of interest to note that 21 of the women under 40 and 3 of those over 40 had since borne children, and 2 others were now pregnant; and, of these 26, 23 had had the cervix removed by the combined operation. To the 24 patients 30 children had been born; 23 labours were natural and 7 instrumental, but in no

case was labour obstructed. Four patients had had two labours each with no recurrence of prolapse; 17 on labour each, with no recurrence, and one was badly torn with a slight recurrence of rectocele. Another had one labour and said that the womb fell slightly when she was tired. Another had three labours, and in this case there was recurrence, requiring another operation. Thus prolapse sufficient to cause inconvenience had only returned in one out of 24 cases. The speaker was therefore of opinion that the addition to these vaginal operations of any abdominal intervention was unnecessary and undesirable, increasing the risk and discomfort to which the patient was exposed. He especially deprecated the use of abdominal measures not in addition to but instead of vaginal surgery.

Dr. F. H. LACEY said that the patients were mostly working women who had to return to work in cotton mills and other laborious work very soon after operation. He had written to 750 patients and received 521 replies, and 455 (87 per cent.) replied to the question, "Did the womb keep up well now?" with the answer "Yes." Of those who said "No" he had examined 29: 17 of these had some prolapse or other discoverable abnormality; one only had proclitidia, and she was aged 75 and had chronic bronchitis. Another had chronic bronchitis and asthma, while another had had to return to the cotton mill immediately after operation. Two others had had labours within one year after; 2 had elongated cervixes, and the remaining 10 had other conditions which had nothing to do with the previous operation—for instance, cystitis and senile vaginitis. The remaining 12 did not feel right, but they showed no anatomical abnormality.

The following table shows the relation of age to success and the percentage of successful cases grouped in decades:

Under 20 (1 case)	100 per cent.
21 to 30 (75 cases)	87 "
31 to 40 (200 cases)	89 "
41 to 50 (108 cases)	95 "
51 to 60 (47 cases)	89 "
61 to 70 (21 cases)	87 "
75 (1 case)	100 "

Taking those of reproductive age, he found that 330 successful cases had 67 children after the operation; 19 improved cases had 6 children; and 33 failures had 16 children. For the 67 children forceps were used in 32 per cent. of cases; for the 6 children forceps were used in 80 per cent. of cases; and for the 16 children forceps were used in 62 per cent. of cases; so that both failures and improved cases showed a higher ratio of labours, and these labours amongst the improved and failures showed a higher ratio of instrumental deliveries. This was what would be expected, and it was obvious that a colporrhaphy or any other operation could scarcely be expected to stand the strain of parturition better than the normal and natural pelvic floor. Dr. Lacey had only seen one death after vaginal operation, and that from pulmonary embolism. He considered abdominal operations unnecessary in the vast majority of cases, but admitted that rarely the abdominal route might be necessary in addition—for instance, in cases of congenital prolapse, or where certain complications existed, such as adhesion in a retroverted uterus. In St. Mary's Hospital no prolonged preparation of the patient was used; only one vaginal douche was given before coming on the table; the vagina was then cleansed with cresol, followed by perchloride, iodine being applied externally. No vaginal douching was used after operation, the parts simply being kept as dry and clean as possible.

Dr. A. DONALD, as a further introduction to the discussion, gave a short account of the history and early technique of colporrhaphy in Manchester. He believed that the operation had been more frequently done in that city than in any other city in this country, and as the oldest member of the present staff of St. Mary's Hospital he was able to speak of the earlier days of the operation. When he was a resident during the years 1884-87 it seemed to him that operative treatment on lines similar to those employed in the radical cure of hernia might be successful, although there was little encouragement in the literature of the subject. It was said that failure always resulted, and the standard textbook indicated that three methods of treatment might be tried: (1) Pessaries in mild cases; (2) a plastic operation on the vagina and perineum to enable the patient to wear a ring pessary in medium cases; and (3) an operation which was meant to

cause a union of the anterior to the posterior vaginal wall in advanced cases. In 1833, as surgeon to the hospital, he put his theory into practice, and in that year operated on six cases, in three of which comparatively full notes of the operation were taken.

The technique then employed was, with certain modifications, similar to his present methods. The cervix was amputated in cases where it was hypertrophied. The vaginal mucous membrane was divided transversely where it was inserted into the cervix in front, and stripped off the cervix. The cervix was then divided into two lips, anterior and posterior, and a wedge was excised from each lip, care being taken to preserve a strip of the mucous membrane of the cervical canal of each lip, which was brought into apposition with the corresponding vaginal mucous membrane. On the anterior vaginal wall a diamond-shaped flap was dissected off, the whole thickness of the vaginal mucous membrane being removed. The raw surface was then brought together with a continuous catgut suture in the deep tissues, and this was covered in and buried when the lateral edges of the cut mucous membrane were stitched in the middle line. On the posterior wall a triangle was mapped out, with the apex close to the cervix and the base at the vaginal outlet. The sides of the triangle diverged, so that at the base they reached the middle of the labium minus of each side. The posterior colporrhaphy was done in stages from above downwards, the triangular flap being separated from its apex for about an inch, and then the sides brought together before the incisions were carried lower down. The deeper tissues were brought together by a continuous catgut suture, which was buried by the stitches uniting the mucous membrane. The healing was not so good in these days, because the catgut was not so reliable and came away early, and in most of the cases there was still a tendency to prolapse; but as a rule they satisfied the condition laid down in the textbooks, and enabled a ring to be retained.

In 1891 he operated on two cases of very bad proclitidia. In both the vagina was completely everted and a large ulcerated mass protruded from the vagina which could not be reduced until after the patient had been in bed for two weeks in one case and for three weeks in the other. In both these cases the operation was completely successful and the prolapse did not return. These cases finally established his belief in colporrhaphy as a curative operation. The number of colporrhaphy operations at St. Mary's Hospital had now enormously increased, and the late Dr. Walls, Dr. Fothergill, Dr. Clifford, and Dr. Fletcher Shaw had all given practical proof of their faith in the operation as a curative measure.

Dr. HERBERT SPENCER was fairly satisfied with vaginal operations and agreed that the abdominal method was unnecessary. He thought that in some cases of severe proclitidia no operation would be certain to cure, but that sometimes the best method might be the removal of the uterus *per vaginam* and packing of the tissues with gauze. He had performed colporrhaphy in 1887. He did not use catgut as he considered it might cause sepsis and tetanus, but instead used buried silk or silkworm-gut passed with a sewing needle.

Dr. T. G. STEVENS considered that, prior to 1913, London was far behind the Manchester school in the treatment of prolapse. He was convinced that the method described by Dr. Fothergill and Professor Donald was the best, that any case of proclitidia, however bad, could be cured by it, and that if failure occurred it was due to the patient getting up too soon or, more rarely, to a subsequent labour. He considered the operation could not be properly done unless catgut was used. There must be every such operation be some risk of sepsis, for the field was not an aseptic one. He preferred raw to chromicized catgut, as in the latter the surface was likely to be hardened and organisms remained intact in the middle, giving rise to sepsis and secondary hæmorrhage. For moderate cases of prolapse as extensive an operation was necessary as in the severe cases, and the more severe the proclitidia the easier was the operation. He considered that abdominal operations played no part in the treatment of prolapse, but in a small percentage of cases—for instance, persistent retroflexion, leading to sacral pain—he had had resort to a Gilliam operation. This, however, had nothing to do with the treatment of prolapse.

Dr. A. E. GIFFS complimented Dr. Lacey upon the amount of work he had carried out in tracing the after-

histories of such a large number of cases. He considered that anatomical cure was the only real criterion of success in the operative treatment of genital prolapse. It was not enough to trust to the patient's report that she felt well; examination might reveal a certain degree of recurrence. He had found the vaginal plastic operation satisfactory in about 96 per cent. of cases. He did not find it necessary to amputate the cervix; if the uterus were put into proper position the hyperplasia of the cervix, which was due to the procidentia, tended to disappear. He protested against wholesale amputation of the cervix except in hyperplasia of the vaginal portion in nulliparae, and claimed that as good results could be obtained by ventrofixation by proper methods, combined in certain cases with the vaginal operation.

Dr. J. E. GEMMELL (Liverpool) favoured the combined abdominal and vaginal methods, and described a method of ventrofixation used by him in which the utero-vesical pouch was obliterated. He had operated upon 480 cases at the Women's Hospital, and had traced the end-results in 192. The answers in all cases were satisfactory. He had done colporrhaphy alone in 40, interposition in 27, and a vaginal plastic operation combined with ventrofixation by his own method in 125. In advanced age he preferred interposition when the uterus was atrophied and there was complete prolapse of the vaginal walls. Especially in young women of child-bearing age he favoured the combined method—the vaginal operation combined with ventrofixation—as there was need of less removal of vaginal tissue, there were better results in parturition, and by his method a new fibro-muscular support was formed for the uterus inside the abdomen.

Dr. WALTER SWAYNE (Bristol) considered that details of technique mattered little; the important thing was that certain anatomical requirements should be fulfilled. Abdominal operation was incorrect anatomically; the damaged pelvic floor must be reconstructed on anatomical principles. He used buried catgut and did no abdominal operation unless there was some such condition present as retroflexion, or diseased ovaries or tubes. Where extensive plastic operations were carried out on women of child-bearing age they should be warned that subsequent labour might destroy the effects of a successful operation.

Dr. C. D. LOCHRANE (Derby) said that the ideal operation for prolapse should meet four requirements: (1) It should restore the parts to normal or as near that as possible; (2) it should be applicable to all ages; (3) it should not interfere with future pregnancy or labour; and (4) it should be the simplest, least dangerous, and least expensive possible. He had come to the conclusion that the vagino-plastic operation gave the best results, and he had during the last six years given up all other types of operation. He emphasized the importance of a careful preliminary examination to determine the sites of injury. He liked to get cases into a hospital three days before operation for vaginal cleansing. A light vaginal pack, soaked in 1 in 1,000 flavine, in saline, was left in overnight, on the night before operation. On the table the vagina, vulva, and perineum were swabbed with flavine (1 in 1,000) and picric acid (2 per cent.) in methylated spirit. He considered a good anterior colporrhaphy of the type described by Fothergill the most essential point. In cases with marked cystocele the bladder should be separated and pushed up before closing the wound. He had found a light application of bipp to the wound in these cases useful in preventing cellulitis. He used no buried sutures, but secured a broad approximation of the levatores ani with figure 8 silk-worm-gut sutures, then closing the wound from above downwards in the usual way with the shortest catgut sutures inserted deeply, and including in their deeper parts the already approximated borders of the levatores ani. The silk-worm-gut was removed on the fifteenth day.

Professor H. BRIGGS thought it was possible to become obsessed with particular methods. It was only important to work along anatomical lines. He used catgut in all cases and thought that Dr. Stevens's secondary haemorrhage might be due to excessive trauma. He protested against elaborate descriptions of special methods and against a tendency to make exaggerated statements.

Dr. WALTER GRIFFITH thought that abdominal operation might be necessary in certain conditions, as where a retroflexed uterus was complicated by adhesions or by prolapsed inflamed ovaries.

Dr. R. H. PARAMORE (Rugby) was surprised that there was no reference to myorrhaphy of the levator ani during the discussion. Was that now considered of little value? He considered that if its edges were brought together the union did not persist, and if it did that would be an abnormal condition.

Professor GAMMELTOFT (Copenhagen) did not consider abdominal operation necessary. He used catgut, and carried out a myorrhaphy of the levator ani in perineorrhaphy.

Dr. J. S. FAIRBAIRN said it was sometimes difficult to judge of the amount of narrowing of the vagina that would follow plastic operations. He only removed the cervix in cases where there was extreme elongation, chiefly owing to the danger of secondary haemorrhage. The position of the uterus varied widely within normal limits, and he considered a symptomatic cure far more important than an anatomical one.

Mr. FURNEAUX JORDAN had for many years done a combined operation, but gradually had come to rely entirely upon the method described by Fothergill. He found he got better results and patients were more comfortable when the cervix was amputated. He believed a plastic operation to be sufficient.

Dr. MILES PHILLIPS thought that no one set procedure would cure every case. Plastic operation alone cured a large percentage of his cases, but in about 4 or 5 per cent., chiefly women over 60 with atrophy of the uterus, he removed the uterus from the vagina, and in addition did an extensive plastic operation, excising a large portion of the pouch of Douglas and stitching the broad ligaments underneath the bladder. He considered abdominal operation unnecessary in prolapse, but a few cases returned with retroversion, and if such failure to get the uterus into an anteverted position could be anticipated, it might be better to do an abdominal operation and complete the cure at the same time.

Dr. T. W. EDEN thought that no set procedure suited every case. He had found the method of vaginal hysterectomy described by Dr. Miles Phillips useful in some cases. Also in congenital prolapse in young women where ligaments and supports were lax and the round ligaments poorly developed it was useful to duplicate the utero-sacral ligaments, obliterating the pouch of Douglas, anteverting the uterus, and at the same time shortening the round ligaments which were lax and long. He emphasized the importance of anteverting the uterus, and considered that if left retroverted recurrence was almost bound to take place.

Dr. W. H. C. NEWNHAM had almost entirely given up the abdominal method and got uniformly satisfactory results by plastic procedures.

Dr. FOTHERGILL, in reply, said that he had very little trouble with secondary haemorrhage, and when it occurred it could be easily checked by packing. Cases complicated by cancer, fibroids, or prolapsed ovaries were not being talked of; the discussion was on genital prolapse. Of course, he operated on such cases by the abdomen. He did not do the interposition operation. Deaths had followed it, and one should not risk killing patients in order to cure prolapse. He did not like vaginal hysterectomy in prolapse, and in his experience some of the worst cases of prolapse had occurred after the uterus was removed. Congenital prolapse might cause difficulty, but in his hands they had been cured by plastic methods.

Dr. DONALD agreed that secondary haemorrhage was one of the drawbacks. He did not pack for it, as the packing stretched the parts too much and spoiled the operation. He considered a symptomatic cure more important than anatomical. The addition of an abdominal operation to a plastic greatly increased the risk, especially in old women, and vaginal hysterectomy often resulted in ultimately increasing the prolapse. He did not trouble about getting the uterus into a position of anteversion.

The afternoon session was devoted to the demonstration of specimens and to short communications. Dr. CLIFFORD WHITE exhibited two specimens showing an unusual condition of sutures after Caesarean section. Dr. EWEN MACLEAN demonstrated a specimen showing a degree of absorption of silk sutures after Caesarean section; hysterectomy had to be done for fibroid five months afterwards, and several silk sutures were found unabsorbed, while microscopically distinct phagocytosis was seen in the uterine wall around

the suture area. The demonstration of these three specimens led to a brisk discussion of the relative merits of silk and catgut in Caesarean section, in which Drs. HERBERT SPENCER, EARDLEY HOLLAND, MILES PHILLIPS, and COMANS BERKELEY took part.

Dr. EWEN MACLEAN demonstrated another specimen showing combined fibromyoma and carcinoma of the uterus. He referred to the rarity of the combination, only 0.4 per cent. in 500 cases in which he had removed the uterus for fibroid. Dr. HERBERT SPENCER and Dr. EDGE both considered that Dr. Maclean's figures showed an unusually low cancer incidence in the fibroid-containing uterus, and the former thought it might have something to do with the district in which Dr. Maclean practised. He had found 6 out of 200 had unrecognized cancer of the uterus, and there were many more cases in which it was recognized.

Dr. HAROLD CHAPPEL showed a specimen illustrating "full time ovarian pregnancy." The foetus had been retained three and a half months after full time; no ovarian tissue had yet been demonstrated in the wall of the sac, but the tube was stretched over it and the ovary of that side was not found. Several speakers discussed the probability of its being a tubo-ovarian pregnancy, and eventually it was decided to have the matter brought up again at the Royal Society of Medicine after completion of the pathological examination.

Dr. G. I. STRACHAN (Cardiff) showed a specimen of an early ovum which he thought to be of not more than twelve to fourteen days' development. In an oblique section through the cephalic extremity the neural matter could be seen just beginning to be differentiated into grey and white.

Dr. F. J. BROWNE (Edinburgh) read a communication entitled "Some points in the pathology of syphilis of the newborn, based upon a study of 35 cases." The author pointed out the necessity, before arriving at a *post-mortem* diagnosis of syphilis, of taking into account all the available evidence—that derived from the clinical history of the parents, the Wassermann test, the placenta, and a complete naked-eye and microscopic examination of the foetus and its internal organs, especially the lungs, liver, spleen, thyroid, thymus, and pancreas. Lantern slides were shown illustrating the histological changes in these organs. The unreliability of naked-eye appearances was discussed, and it was pointed out that the only evidence obtainable of the presence of syphilis might be the histological changes in the organs. The paper was discussed by Dr. EARDLEY HOLLAND, Dr. SWAYNE, and Dr. STRACHAN.

Mr. GORDON LUKER read a paper entitled "Notes on 250 cases of ectopic gestation." Dr. LAPTORN SMITH, Dr. PURSLOW, Dr. EARDLEY HOLLAND, Dr. GILES, Dr. WILLIAMSON, and Mr. CARLTON OLDFIELD taking part in the subsequent discussion.

Dr. WALTER SWAYNE (Bristol) then read a paper on a case of chorion-epithelioma in a nullipara; there had been three months' amenorrhoea, followed by irregular haemorrhages; the patient was aged 50, unmarried, and a virgin. The primary growth was in the uterus, with secondary growths in the mesentery and lymph glands.

Dr. STEVENS led the discussion that followed, and doubt was expressed by several speakers as to whether the case was really one of chorion-epithelioma, the microscopic section on view showing no evidence of the presence of syncytium.

In the evening an enjoyable dinner was held, the chair being occupied by Mr. CHRISTOPHER MARTIN. The toast list included, in addition to "The King," "The Visiting Societies," proposed by the CHAIRMAN and responded to by Dr. MILES PHILLIPS, and "The Midland Obstetrical Society," proposed by Professor H. BRIGGS and responded to by Sir EDWARD MALINS. The morning of Saturday, June 4th, was spent in witnessing operations at the different hospitals of the city, and arrangements were made for golf and excursions in the afternoon.

Thus has come and gone the first British Congress of Obstetrics and Gynaecology—one that was voted by all who were present to have been a great success from both the scientific and the social points of view. This was largely due to the excellence of the arrangements made and the hospitality shown by the Midland Obstetrical and Gynaecological Society, the secretary of which, Mr. Beckwith Whitehouse, upon whose shoulders most of the work naturally fell, is to be heartily congratulated.

PATHOLOGICAL CHANGES IN BREAST EPITHELIUM.

At a meeting of the West London Medico-Chirurgical Society held at the West London Hospital on June 3rd, with the President, Dr. F. J. McCANN, in the chair, a paper was read by Sir G. LENTHAL CHEATLE on some pathological changes in the epithelium of the breast. He said that he would confine his remarks to two main points: (1) to indicate the surgical importance of the ampullae of the breast ducts; and (2) to draw attention to three separate conditions in the breast, all of which had been described to him as "parenchymatous mastitis" by different observers, but of which, in his opinion, only one could be thus justly described.

1. Whole sections of two breasts were shown: in one the ampullae of two ducts contained papillomatous tumours, while in the other one duct ampulla contained an even larger papillomatous tumour. All the ampullae containing the tumours were distended by the growths. Whole sections of a third breast were next shown in which the ampullae of two ducts were distended by cancer. The cancer was undergoing colloid degeneration at the time of excision of the breast. It was pointed out that these sections demonstrated simple growths in one case and malignant in the remaining two, all occurring in the ampullae of the ducts. Sections were then shown of mammary ducts ending in the nipple surface. There was nothing to guard against the entrance of irritating agents except the contraction of the dense musculature surrounding the ducts. Irritating agents might collect in the ampullae and there act undisturbed upon the epithelium lining the duct dilatations.

2. Sir Lenthal Cheatele first dealt with only one of the three conditions he had mentioned which in his opinion justly deserved the term "parenchymatous mastitis." A longitudinal section of an affected duct was shown which exhibited in its surface a localized patch of swollen epithelium. Among the epithelial cells were lymphocytes, a few polymuclear leucocytes, and also newly divided connective tissue cells. There was no ulceration in this duct. Another duct from another breast was also shown in longitudinal section. It contained a patch in which the same process seen in the previous section was occurring, but it had been more intense in character and the surface of the duct had been ulcerated. This condition must be parenchymatous mastitis. It occurred in breasts in which some chronic disturbances were in progress, such as in advanced cancer. In many cases the ducts only were affected, but in some the ducts and a few of the acini with which they communicated were also affected. It could not be very uncommon to find all the acini involved and some of their ducts sharing in the inflammatory changes. His next point was the condition he was anxious to remove from the nomenclature of parenchymatous mastitis, and he showed many sections of breasts which demonstrated his point. He preferred to call it a "diffuse benign neoplastic state." In many cases the ducts only might be affected; in other parts both the ducts and acini were undergoing a similar change. The changes were these: there was a proliferation of epithelium lining the ducts and perhaps some of the acini in connexion with them. The cells which resulted from this proliferation appeared as desquamated cells and collected in great numbers and distended the ducts. This neoplastic change the lecturer considered a common cause of cysts in the breast. There was practically no inflammatory change seen in this condition. Where in some cases collections of lymphocytes could be demonstrated these collections were so far apart and small that it appeared impossible to conceive that they could be causing the neoplastic change. These changes he regarded as secondary. Papillomata were not present in this condition. The third condition described to him as being a form of parenchymatous mastitis he regarded as a state of cancer. Sections were shown in which the ducts, distended with epithelial cells, were being ulcerated by infiltration into surrounding parts by these cells. The subjects from whom were prepared some of the specimens shown of this type of breast had died of cancer.

The President congratulated the lecturer on the excellent series of whole breast sections he had shown. He emphasized the close connexion that existed between papillomatous changes and cancer, referring particularly to these conditions in the uterus.

Mr. McADAM ECCLES recalled that the late Mr. Keetley, the founder of the society, had many years ago expressed the belief that cancer of the breast was always due to infection through the ducts. Mr. Eccles was certain there was a close connexion between papillomata and infection. This was well seen in the case of the bladder. He regarded also many of the cysts of the epididymis as of infective origin. In doubtful breast conditions in women over 50 he thought it safer to advise complete removal of the organ, but not necessarily of the muscles and lymphatic tracts.

Dr. RICKARD LLOYD referred to cases in his practice in which cancer had been proved in patients presenting scanty evidence of the true condition on clinical grounds. He also mentioned cases in which life had been prolonged many years after operation at an early stage for cancer.

Dr. KNYVETT GORDON spoke as a pathologist of the difficulty in many cases in deciding what the true condition was from an examination of only a small portion of the breast. The whole breast section was undoubtedly the best method, but was often impossible. He thought that when intra-acinar proliferation was marked the whole breast should be removed, and where the basement membrane was ruptured the muscles and lymphatic tracts should be removed as well. He did not agree that duct papillomata were necessarily benign.

SURGERY OF NASAL DEFORMITIES.

At a meeting of the Medico-Chirurgical Society of Edinburgh on June 1st, Sir JAMES B. HOBSPON presiding, Dr. DOUGLAS GUTHRIE read a paper on the surgery of nasal deformities. He emphasized the importance of immediate replacement of the injured and deformed parts, and of not forgetting the possibility of septal deflection. Of the common types of deformity, he took first that of lateral deformity or twisted nose; with this there usually was also some deflection of the septum, with partial or complete blockage of the nostrils. The treatment was a sub-mucous resection of the septum; division of bone was rarely necessary. The second group was that of sunken bridge or saddle nose, produced by violence, by an excessive resection of the septum, or by syphilitic disease. Cases of successful treatment of this type of deformity by cartilage graft were described. The graft was obtained from the seventh costal cartilage, and the advantages of such a graft were that it was a natural tissue, that it could be readily shaped to fill the gap, and that it persisted unchanged. The results were least satisfactory in syphilitic disease. The third type was that of nostril deformity, of which three examples were given—one a deflection of the lower end of the septum, one a stenosed nostril produced by redundant tissue of the graft of a previous plastic operation, and the other a case of alar collapse.

Mr. D. M. GREIG advocated the use of paraffin in preference to a graft operation in cases of sunken bridge where the condition was congenital and without scarring; the operation was easy to perform, could be carried out in the out-patient room, and had given him excellent results.

Dr. GUTHRIE, in reply, said that his only experience of the paraffin had been in removing it where it had failed; it wandered into distant tissues, even into the eyelids, where it gave much trouble.

Treatment of Fractures of the Upper Extremity.

Mr. J. W. DOWDEN discussed the principles of the treatment of fractures of the upper limbs. The classical use of splints and prolonged fixation of the parts might give a good result, but much time was wasted. Lucas-Championnière had revolutionized the older treatment by his advocacy of early massage and passive movement. The speaker carried the new doctrine a step further, and advocated early active movement. The principles of his treatment in fractures of the upper extremity were as follows: A sling supported the forearm, the angle at the elbow was altered several times a day, and the range was steadily and painlessly increased. Active movements of all joints and muscles were frequently carried out during the day, increasing the range steadily, and following on the heels of pain. Pain was absolutely the indicator of how far active movement might be carried, and the method was so simple that it could be carried out by young children as well as by adults. Cases of fracture of

the clavicle, of the scapula, humerus, elbow, forearm, and wrist were described, and the injuries, with the functional and anatomical results, were illustrated by x-ray photographs. Certain regions offered special difficulties, notably the elbow and wrist, but even there the results were superior to those of the conventional methods. He had used the method also in severe compound fractures due to war injuries, where its superiority was equally marked; he had not had a case of non-union in compound fracture of the humerus treated in this way.

Mr. C. W. CATHCART said that the results given by this method were well founded, and were an advance in the treatment of fractures; they broke through the dictum that a good functional result could not be obtained without a good anatomical result. But he was doubtful if the method could be applied to fractures of the lower extremity. Mr. D. M. GREIG expressed general agreement, but said that in fracture of the olecranon and in fracture of the humerus in babies it was not suitable. Mr. PIRIE WATSON said he had adopted the method in surgical out-patient work, modifying it by the use of splints for the first few days. Dr. C. SOMERVILLE reported a case of fracture of the ulna in a chauffeur treated by this method, where the man was using the arm again at his work fourteen days after the injury.

Keratoderma Bleorrhagica.

Dr. DAVID LEES reported two cases of this rare condition, showing casts and photographs of the skin lesions. The lesions, horny heaped-up growths on the skin, with parchment-like areas between, were commonest on the soles of the feet, but occurred also on the legs, scrotum, back and abdomen. Forty-seven cases in all had been recorded. The condition was a manifestation of gonococcal toxæmia of severe degree, and polyarthritis was usually present, and also urethritis; only once had gonococci been obtained from the skin lesions. His first case was a man aged 22, who had unusually extensive skin lesions, with a negative Wassermann and positive gonococcal tests. His treatment was as follows: Local application of a solution of arsenic and ipecacuanha in rectified spirit; large doses of gonococcal vaccine (twenty thousand million) after preliminary desensitization; and injections of novarsenobillon. The condition was cured in six weeks and had not recurred. In the second case, a woman aged 63, with the characteristic lesions on the soles and legs, bacteriological and serological proof of gonococcal infection was lacking, and the Wassermann test was also negative. A similar course of treatment was given, and again the horny growths had entirely disappeared. In three months they relapsed, but again cleared up after a second course of novarsenobillon.

Rebicus.

DEFICIENCY DISEASE.

McCARRISON'S *Studies in Deficiency Disease*¹ is a notable book. It is one which demands careful study and full consideration by all medical men. It comes at the right time when our knowledge of the vitamins is crystallizing, and when the new idea that disease is not necessarily due to the activity of a positive agent, but to the absence of indispensable ingredients of diet, is sinking in. As was to be expected, most attention is directed to the conditions caused by absence of the antineuritic vitamin, for it was in relation to that material that the author made his name by his published researches. But quite an adequate account is given of the effects due to the withholding of other vitamins, including the disease pellagra, which in all probability is not quite on all-ours with the other ailments, now labelled as Deficiency Diseases.

"Vitamins are as the spark which ignites the fuel mixture of a petrol-driven engine liberating its energy. The spark is of no use without the fuel, nor the fuel without the spark—nay more, the efficacy of the spark is dependent in great measure on the composition of the fuel mixture."

These illuminating sentences (p. 210) really put the whole problem in a nutshell. Absence of food leads to

¹ *Studies in Deficiency Disease*. By Robert McCarrison, M.D., D.Sc., Hon. LL.D., Belfast. London: Henry Frowde, and Hodder and Stoughton, 1921. (Sup. roy. 8vo, pp. 285; 82 figures. 30s. net.)

starvation; absence of the vitamins renders the food useless, and so also leads to inanition. Inanition or starvation is the essence of all deficiency diseases; the malnutrition so produced renders the tissues an easy prey to infectious agents, so that conditions due secondarily to the latter may cause further symptoms to be superimposed on those due to failure of the food supply. It was first by Dr. McCarrison's work on the effect of avitaminosis, in which he examined the various organs and tissues of the body, that he proved this thesis up to the hilt. The abundant histological features of the effects in these tissues will convince the observer of the similarity in the two cases, starvation and avitaminosis. The remarkable effect on the adrenal body, which hypertrophies, is a case in point. Endocrine insufficiency in other organs is another most important factor, and gastro-intestinal disturbances are pre eminent. It is no doubt true that the absence of individual vitamins will produce different effects, and it is useful to be able to speak of the vitamins A, B, and C as being antirachitic, antineuritic, and antiscorbutic respectively; but underlying all, starvation is at the root of the matter.

A preliminary cursory perusal of the book makes one think the matter is presented in rather a muddled way. Chapters are given which deal more especially with rickets, scurvy, etc. (each, by the way, provided with a useful summary at the end), but, speaking generally, there is no hard-and-fast line drawn between them. When, however, the book is studied carefully, one sees that there is sanity in the author's method. No hard-and-fast line can be drawn because no such line exists; a vitamin cannot be studied individually without consideration of the activities of its fellows. Take, for example, vitamin B so often spoken of as antineuritic, because neuritis is so prominent a symptom in beri-beri, where that vitamin is absent; neuritis is prominent, but it is not the only symptom; other symptoms and other effects are the result of general malnutrition.

The author does not simply describe the effect of his numerous and painstaking experiments on animals (rats, guinea-pigs, monkeys, birds, etc.), the special value of his work lies in their direct and immediate application to man. His commendation of Hindbede's view, in one of the earlier pages makes one think that Dr. McCarrison must be a vegetarian or has leanings in that direction. He certainly recognizes how animals are dependent on the plant world for their vitamin supply, but any suspicion of pure vegetarianism is at once dispelled when one reads the closing chapters, which deal more particularly with the practical applications of his work to human dieting. There we have profound and intimate knowledge of the human wants to be supplied, not only with adequate, but with properly balanced rations.

Before the discovery of the vitamins attention was in the main directed by dieticians to the quantity of the food supplied. The quantity is important, and enough must be given to supply the body with repairing materials and to form the source of the energy dissipated. The quantity of petrol in the tank puts a limit to the work a motor car can perform. But quantity is not the end-all; the sparking apparatus must be in order too. The quantity of vitamin necessary in a diet is infinitely small; its presence is indispensable, and comes under the head of quality rather than quantity. The whole attitude of dieticians accustomed in the past to speak in terms of calories, and little else, has altered. There are proteins; and proteins, fats and fats, and so forth, and not the least important—perhaps the most important—qualitative factor is the presence of these accessory food materials about which we chemically know next to nothing.

It is customary, in dealing with the subject of diet, to suppose that in a mixed diet such as the well-to-do have at their command the risk of deficiency disease is minimal, for an item lacking in one article of food will be made up for in another. This probably is the fact, and so pity for the poor follows, because they have, *volens volens*, to take a restricted diet both in amount and kind. At the same time it is not the poor only who suffer. Infantile scurvy, latent or declared, is an ever-present danger, and is as common in the children of the rich as of the poor, probably more common, so widespread is ignorance of the principles of dieting, and so great the affection of the public for fractionated, treated, widely advertised and expensive substitutes for natural foods. Without going into many details of cases where ill-balanced nutriment upsets health

one cannot refrain from alluding to the case of the unfortunate boy fully described on page 238 et seq. He was in a good social position, had happy and hygienic surroundings, and a dietary "varied enough and liberal enough," but yet did not thrive. On examining his food it was found that the variations had been rung on just the wrong things. His recovery when fed on a diet of the right sort was remarkable. The case which follows this—that of a lady—is equally instructive, but space forbids a fuller description. Those who read this review must obtain the book and inwardly digest it.

A moot point still unsettled is the part that diet plays in the etiology of rickets, and the causation of bad teeth so closely allied to it. No I Paton and his colleagues have seen reason to doubt whether vitamin deficiency is at the root of this malady, and their recently published results were too late to be noticed in the present book. One anticipates that a second edition will soon be called for, and then we shall look forward to what Dr. McCarrison has to say on this disputed question. Until then we must be content with congratulating the author on his first edition and with recommending our readers to study it for themselves.

W. D. HALLIBURTON.

VACCINE AND SERUM TREATMENT.

OF SERGEANT, RIBADEAU-DEMAS and BABONNEIX'S *Traité de pathologie médicale et de thérapeutique appliquée*,² which is to consist of 32 volumes, the tenth volume to appear is that numbered xxx. on bacteriotherapy, vaccinotherapy and serotherapy, with, as its second part, occupying 200 pages, an account of remedies in common use arranged according to their therapeutic action and not in alphabetical order, by H. Carron.

The first, and by far the most interesting, part deals with the modern methods of treatment derived from the science of bacteriology. It is written by Dr. Pierre Pruvost, who points out in the introduction that serums and vaccines exert both specific and non-specific effects, the latter being connected with changes in the colloid equilibrium of the body fluids and the blood changes preceding shock and anaphylactic phenomena described by Widal and his co-workers as the haemoclastic crisis. For practical purposes the various methods employed are divided into three categories: the first contains those forms of treatment which have a well-established position, such as antidiphtherial, antitetanic, antityphoid, and antimeningococcal serums; the second a large number of vaccines and serums which, though often useful, are not constantly effective; and the third group consisting of those which, while of high scientific interest, have not yet been adopted in practice. In the section on bacterial therapy, or the use of living and harmless bacteria, with the object of exerting an antagonistic action on pathogenic organisms, the treatment with lactic acid bacilli is fully described, and reference is briefly made to pyocyanase.

The various vaccines are described in detail, with clear directions as to the contraindications to their use; the section on antityphoid inoculation occupies twenty pages, and deals with both its prophylactic and curative applications. The protection conveyed is regarded as lasting on an average for a period not exceeding two to three years, and the curative effect, of which quite a moderate estimate is made, is stated to be more satisfactory in early life.

The section on serum therapy deals first with saline injections, then gives an account of anaphylaxis and serum reactions, and finally supplies a detailed description of the various serums, those on antidiphtherial and antimeningococcal serum being particularly full. In the special chapter on non-specific serum treatment the administration of horse serum in haemophilia receives full attention, and the difficult subject of injections of proteins is discussed. A well-illustrated chapter on blood transfusion and some general conclusions complete Dr. Pruvost's valuable and up-to-date contribution.

²*Traité de pathologie médicale et de thérapeutique appliquée*. Publié sous la direction de Emile Sergent, L. Ribadeau-Dumas et L. Babonneix. Tome xxx. Thérapeutique; tome ii. Bactériothérapie, vaccinothérapie, sérothérapie, formulaire de thérapeutique. Par Pierre Pruvost et H. Carron. Paris: A. Maloine et Fils. 1921. (Demy 8vo, pp. 524; 35 figures. 28 francs.)

AN AMERICAN TEXTBOOK OF GYNAECOLOGY.

ANY textbook of gynaecology which appears with the imprimatur of Dr. John G. Clark obtains thereby a good send-off, and is certain to receive more than passing attention from those to whom Dr. Clark's name stands for all that is soundest in American gynaecology. Dr. BROOKE M. ANSPACH is to be congratulated, therefore, not only upon having such a godparent for his new book,³ but also upon his having made the book worthy of its sponsor. Founding on an accurate, full, and lucid description of the anatomy and physiology of the reproductive organs in woman, the author follows the usual procedure of discussing the causes in general of pelvic disease and the methods of investigating it. The examination of the urinary system is particularly fully dealt with, and includes catheterization of the ureters, pyelography, and the estimation of the renal function. In his description of the diseases and abnormalities of the different organs Dr. Anspach follows the topographical classification, and while we may regret the sacrifice of strict scientific perspective which this arrangement entails we cannot but admit that on the whole it makes the subject simpler to the student or practitioner who has not given special study to the subject; together they form the public for whom the book is designed. An attempt to redeem the sacrifice is made by devoting separate chapters to the special peculiarities of certain forms of infection, notably gonorrhoea, tuberculosis, and syphilis.

The last sections of the book are occupied with the description of therapeutic measures, operative and medicinal. Special sections of considerable value are devoted to the discussion of radium and x-ray therapy, and to the use of vaccines in gynaecology. The book is sumptuously illustrated by 526 figures, most of which are well designed and likely to prove helpful. At the end of each section is a short but carefully selected bibliography of the more important papers on the subject, culled from both the more classic sources and the most recent work. Dr. Clark in his introduction makes particular reference to this, and we agree that the author has exhibited great discrimination in his choice of references.

The general impression that the book has made upon us is that, without being encyclopaedic, it is full and complete, accurate, lucid, practical, and throughout written with the restraint that is the hall-mark of a well-balanced judgement. We congratulate Dr. Anspach accordingly. Not for a long time have we seen an American textbook so well calculated to become popular with students on this side of the Atlantic as well as in the land of its birth.

A YEOMANRY MEDICAL OFFICER.

THE titanic struggle on the Western Front to a large extent overshadowed the campaigns elsewhere, at any rate in popular interest, and this probably applies to the medical service equally with other branches. Captain TEICHMAN, by publishing his *Diary of a Yeomanry M.O.*,⁴ has rendered a distinct service to the medical records of the war, and his daily record of the doings of a regimental medical officer cannot fail to interest many whose experience was largely confined to the trenches of France. So rarely, except in the last phase, did open fighting occur in France, that the account of the Egyptian and Sinai episodes seems to refer rather to war as understood before 1914, when troops moved in the open, cavalry patrols were constantly engaged, and the enemy showed an enterprise, and yet a regard for the common usages of warfare, which was far removed from the ruthless bitterness of the Germans as exhibited in France.

Captain Teichman does not profess to give any critical description of the operations in the various fields, but in homely fashion jots down the doings of his own regiment, the Worcester Yeomanry, adding such explanations of the general movements as a regimental officer could get to know. He is modest about his own deeds, but it is possible to read between the lines and to recognize that he must have been a most excellent regimental M.O., not sparing himself in work, nor thinking of personal risk. That he was twice wounded is sufficient proof of this,

apart from the decorations which indicate what others thought of his work. It is impossible to estimate what it means to a regiment to have a medical officer who is always "up" with them, and the R.A.M.C., with many fine achievements to be proud of, may regard as its finest the fact that there was a constant flow of such men, who by their cheery optimism as well as their medical and surgical skill did so much to sustain the spirits of all ranks. The value of a medical service depends as much on this as on its technical abilities. Regimental work was often a matter of personal self-sacrifice to a keen professional man, for his opportunities for more than elementary first aid or hasty symptomatic treatment were scanty, and it was only the recognition of the opportunities for the wider scope of service that reconciled the doctor to his very limited professional field.

Of special interest is the description of the difficulties of arranging transport for the wounded, and how they were overcome. Dhoolies, traverses, sand carts, and mule and camel litters were all employed, and the Ford ambulances were of great use in Sinai. Little reference is made, however, to the bugbear of all work in France—the ever-present sepsis—and it would seem that this was a problem of comparatively small importance. Tropical diseases, particularly malaria, gave rise to much more anxiety. It is tempting to follow the author over the various fronts, and to quote some of the incidents he records. The despatching of a venomous snake by D.R.L.S. to the A.D.M.S., who desired specimens for the preparation of antivenene, is a case in point, and the urgent "stop" wire from that officer, who was probably inundated with infuriated and highly venomous reptiles, recalls instances which occurred elsewhere of an order producing embarrassing results.

Until he was drafted to Italy, just before the end, Captain Teichman was fortunate, probably exceptionally so, in returning to his own unit each time after he was a casualty, and therefore the *Diary* is a regimental as well as a personal record; it will be perused by the Yeomanry with as much interest as by its medical readers, who should be numerous.

NOTES ON BOOKS.

PROFESSOR ARTHUR THOMSON'S well known *Outlines of Zoology*⁵ has now reached a seventh edition. It has undergone revision in order to bring it up to date, and by some additions the number of illustrations has been raised to 437. The book is perhaps of more use to the student of general zoology than to the medical student, since it contains much that is not required by the latter: yet every intelligent student will find interest in the chapters dealing with such subjects as geographical distribution and the doctrine of descent, which make the dry bones of morphology of more living interest. Moreover, it is just these very subjects in which Professor Thomson is a past master of the art of exposition. The new edition, which is the seventh, contains a bibliography of the more important textbooks and books on natural history, together with a number of representative test questions for students, which will be of considerable value to the "home student."

*The Canadian Mother's Book*⁶ is a sensible little book written in simple—and sometimes rather ecstatic—language, for the expectant and nursing mother; it is issued by the Child Welfare Division of the Canadian Department of Health. It emphasizes, more than most books of this nature do, the fact that practically every mother, if properly instructed, ought to be able to nurse her baby. "We are all responsible," it says, "for the folly of artificial feeding."

Colonel G. T. BIRDWOOD'S *Clinical Methods for Students in Tropical Medicine*,⁷ of which the third edition has recently been published, is a book which does not waste a word, but in a very practical and pointed manner carries out what it sets out to do. In the new edition Colonel Harvey has rewritten the chapter on the Wassermann

³ *Gynecology*. By Brooke M. Anspach, M.D., Associate in Gynecology, University of Pennsylvania. With an introduction by John G. Clark. London: J. B. Lippincott Company. 1921. (Med. 8vo, pp. 775; 526 figures. 42s. net.)

⁴ *Diary of a Yeomanry M.O. (Egypt, Gallipoli, Palestine, and Italy)*. By Captain O. Teichman, D.S.O., M.C., Croix de Guerre, Croce di Guerra; Royal Army Medical Corps (T.F.). London: T. Fisher Unwin, Ltd. 1921. (Med. 8vo, pp. 283, illustrated. 12s. 6d. net.)

⁵ *Outlines of Zoology*. By A. J. Thomson, M.A., LL.D. Seventh edition, revised. Edinburgh, Glasgow, and London: H. Frowde, and Hodder and Stoughton, 1921. (Cr. 8vo, pp. 810; 437 illustrations. 18s. net.)

⁶ *The Canadian Mother's Book*. Ottawa: The Deputy Minister, Department of Health. 1921.

⁷ *Clinical Methods for Students in Tropical Medicine*. By G. T. Birdwood, M.A., M.D., D.P.H., Lieut.-Colonel I.M.S.; with foreword by Sir J. Roberts, Kt., C.I.E. Calcutta and Simla: Thacker, Spink, and Co.; London: W. Thacker and Co. 1920. (Fcap. 8vo, pp. 391, Rs. 7.8.)

reaction, and Major Megan has written a chapter on the examination of faeces. Colonel Birdwood has contributed new chapters on the recent treatment of leprosy, the management of hookworm disease, and the identification of poisonous snakes. The book is very usefully interleaved, but the index might well have been improved. It is, however, certainly a volume which every student of tropical medicine should possess.

In *The Octocentenary of Reading Abbey* Dr. JAMIESON B. HURRY* has given an interesting sketch of the Noble and Royal Monastery of Reading, founded on June 18th, 1121, by Henry I, who was buried there after his death, on December 1st, 1135, from "a surfeit of lampreys," to which he appears to have been both partial and sensitive, for as this fish always made him dyspeptic it had been banned by his physicians. In 1164 Thomas à Becket dedicated the abbey church to the worship of God, and twenty-one years later Heraclius, Patriarch of Jerusalem, knelt here before Henry II and unsuccessfully implored him to save Jerusalem from capture by Saladin. It was in Reading that, about 1240, the unknown monk composed "Sumer is icuming in," one of the earliest examples of English secular music. King Henry VIII dissolved the abbey, and in 1539 the last abbot, Hugh Cook Faringdon, after a sham trial for treason, was executed before the gateway of his own stately abbey. Reading is, indeed, fortunate in its historian who has produced this attractively written and finely illustrated volume.

* *The Octocentenary of Reading Abbey (1121-1921)*. By Jameson B. Hurry, M.A., M.D. London: Elliot Stock, 1921. (Imp. 8vo, pp. 101; 10 plates. 10s. 6d. net.)

ROYAL MEDICAL BENEVOLENT FUND.

At the last meeting of the Committee, held on May 10th, twenty-one cases were considered, and £308 voted. The following is a summary of the cases relieved:

Daughter, aged 73, of M.R.C.S. Eng. who died in 1891. Owing to a limited income and having to help towards the expenses of a bed-ridden brother in a nursing home, applicant has asked the Fund to help her to supplement her £100 annuity of £40 and the £4 she was paid for making fancy bags and painting little water-colour sketches. Since the war she has had to pawn family things and pay a heavy rate of interest. Her sister applied to the Fund and the Committee made her a grant of £10. Voted £10.

Widow, aged 25, of M.R.C.S., who died of typhus while working on a Red Cross train in 1920. Applicant managed to escape from Russia with her little son and arrived in England without means and is at present being supported by friends. She is very anxious to be self-supporting and to this end has applied to the Fund for help and to advise in placing her son in a school. Voted £10.

Widow, aged 55, of L.F.P.S., who was acting as surgeon on board when torpedoed and all were lost. Applicant receives a pension from the War Risk Association of £5 6s. 8d. a month. Rent 11s. a week. Her youngest son, who is in the merchant service, is now out of work, and applicant finds it difficult to support two on her small pension. Voted £10 in two instalments.

Widow, aged 80, of L.R.C.S.I. and L.R.C.P. Edin. who died in 1918. Her sole income consists of £50 per annum derived from insurance. Applicant asks for help to supplement this amount as her rent is £10, and her board costs 15s. per week. Voted £18 in twelve instalments and also a special grant of £6.

Widow, aged 55, of L.S.A. who died in 1921. Owing to illness applicant's late husband was helped by the Fund. His widow asks for help as she has no settled income. She receives from friends about £25 per annum, and 7s. 6d. a week by letting rooms; her rent is 17s. 6d. a week. Voted £10 in two instalments.

Subscriptions may be sent to the Honorary Treasurer, Sir Charles J. Symonds, K.B.E., C.B., F.R.C.S., at 11, Chandos Street, Cavendish Square, London, W.1.

The Royal Medical Benevolent Fund Guild is overwhelmed, in these days of exorbitant prices for clothing and household necessities, with applications for coats and skirts for ladies and girls holding secretarial posts, and suits for working boys. The Guild appeals for second-hand clothes and household articles for the benefit of the widows and children who in happier times would not have needed assistance. The gifts should be sent to the Secretary of the Guild, 43, Bolsover Street, W.1.

MESSRS. BAILLIÈRE, TINDALL AND COX'S current catalogue gives a list of recently published new books and new editions, with descriptive notes. For the convenience of those who wish to order direct from the publishers, the weight of each book is given and the postal rates.

THE thirty-fifth annual meeting of the American Orthopaedic Association was held at Boston, Mass., from June 2nd to 6th. In addition to many contributions made by the leading American orthopaedic surgeons were papers on "The manipulation of stiff joints" and on "Surgical aspects of milk-borne tuberculosis," by Sir Robert Jones, and another on "Peripheral nerve injuries," by Mr. Harry Platt. Sir Robert Jones also gave clinical and operative demonstrations.

THE VOLUNTARY HOSPITALS COMMITTEE.

WE gave last week, at p. 870, a preliminary account of the report of the Voluntary Hospitals Committee, together with a summary of those recommendations which, if adopted, would require legislative or executive action. The Committee was appointed by the Minister of Health on January 25th, 1921, with Viscount Cave as chairman, "to consider the present financial position of voluntary hospitals and to make recommendations as to any action which should be taken to assist them." In an interim report, described in our issue of March 26th, p. 468, the Committee urged that contributions to voluntary hospitals might reasonably be made out of the available surplus funds of approved societies.

The final report, published on June 9th, is discussed elsewhere in a leading article. We propose to give here a more detailed account of certain matters of general interest, quoting from those sections which specially concern the medical profession.

In order to expedite its report, the Committee limited the evidence to witnesses representing groups of hospitals, or hospitals which might be taken as typical of a number of similar institutions in various parts of the country. Some of the Scottish evidence was heard on behalf of his colleagues by Lord Lighthgow in Edinburgh, and some of it by the Committee in London; the Irish hospitals were not included in the reference. The oral evidence was supplemented by a questionnaire issued to all hospitals outside the London area. The Committee also took evidence from representatives of the Royal Colleges of Physicians and Surgeons, the British Medical Association, the British Hospitals Association and its committees, King Edward's Hospital Fund for London, and from the superintendents of three Poor Law infirmaries.

The Present Financial Position.

In the area covered by King Edward's Fund there are 117 voluntary hospitals of different kinds, including cottage hospitals; in the rest of England and Wales there are 728 hospitals, including general, special and cottage hospitals; in Scotland there are 107 hospitals; making a total for Great Britain of 952. The number of beds available in these institutions at the end of 1920 was approximately 12,797 in London, 31,265 in the rest of England and Wales, and 8,132 in Scotland—a total of 52,194. Besides these there are Poor Law infirmaries with some 92,000 beds, and a number of convalescent homes.

The financial position is gravest in the London area; in the provinces the conditions, though in some cases serious, are in general more satisfactory; while in the Scottish hospitals the outlook is more hopeful still. Reviewing the financial position as a whole the Committee comes to the following conclusion:

"While in certain areas and at particular hospitals the governing bodies have been able to encounter the difficulties caused by the war without permanent injury to the institutions under their care, the position of a large number of hospitals is such as to make it improbable that they can be continued on a voluntary basis unless prompt and vigorous measures are taken to re-establish the position of 1914. The receipts have not fallen off—indeed, they have increased; but the cost of provisions, drugs, dressings, fuel, and labour has grown to such an extent that it far more than counterbalances the increase of income. . . . Under these conditions we estimate that unless some remedy is found there will be deficiencies in the present year in respect of the hospitals in the whole of Great Britain, including London amounting to not less than £1,000,000, and this without any provision being made for the necessary extensions and improvements. The position thus disclosed appears to us to involve danger to the whole of the existing hospital system."

The Committee's Proposals.

The Committee proposes, therefore, to consider the steps that should be taken to meet this serious contingency, and a reasoned statement is given of the losses which might be incurred if the voluntary system came to an end. Convinced that this system is worth saving, any proposals for continuous rate aid or State aid are ruled out.

* Cind. 1355. To be obtained from any bookseller or direct from H.M. Stationery Office. Price 3d. net.

Nevertheless, if the hospitals are to be saved from immediate disaster and restored to the position of security they occupied before the war, it is held that some assistance must forthwith be given from public funds. This, however, should be temporary only, and on the understanding that it is not to be continued beyond a limited period—say two years. Neither should any grant be made except to a hospital which can show that it is doing its best to re-establish its finances, and that it has a fair prospect of so doing before the end of the period of probation.

In regard to the machinery for administering the proposed grant, the Committee recommends the setting up of a central body for Great Britain whose first and principal duty would be to dispense the temporary grants.

"This central body should be formed on the lines of the University Grants Committee, and might bear the name of the 'Hospitals Commission.' It should be appointed by the Minister of Health and should consist of not more than twelve members, of whom the chairman and three others should be selected by the Minister of Health and one by the Secretary for Scotland, and of the remainder one should be nominated by each of the following bodies, namely: The Joint Committee of the Red Cross Society and the Order of St. John of Jerusalem; King Edward's Hospital Fund for London; the British Hospitals Association; the Royal College of Physicians; the Royal College of Surgeons; the British Medical Association; and the Scottish Committee of the British Medical Association. Service on the Hospitals Commission should be voluntary, but it should be advised by a technical expert and will require a small clerical staff. Its expenses should be borne on the votes for the Ministry of Health."

In order to deal with local questions of finance and policy it is recommended that the Commission should have the assistance of committees with local knowledge and influence set up in each area; to these all applications to share in the grant should in the first instance be made. King Edward's Fund would perform this function for London; elsewhere the normal unit should be the county or county borough.

The Committee is impressed with the view, put before it by many witnesses, that the present lack of organization and co-operation among the voluntary hospitals not only detracts from their efficiency, but is the cause of much avoidable expenditure. Subject to certain exceptions in the case of teaching and special hospitals, the Committee sees no reason why arrangements should not be made both for defining the functions of hospitals and promoting co-operation among them:

"If there were some body, such as a Voluntary Hospitals Committee, with authority to organize and grade the hospitals in a district and to act as a clearing house for patients requiring accommodation, a considerable saving might be effected."

Voluntary Hospitals Committees, being independent of the hospitals and able (by their control of grants or funds) to bring pressure upon hospitals

"would be in a position to collect information, to advise as to accounts and expenditure, to marshal appeals for funds, to act as a clearing house for patients, to promote the grading and the co-operation of the hospitals in their area, and to deal with the other matters referred to in the later paragraphs of this report."

Poor Law Infirmaries.

On the relations of the voluntary hospitals with the Poor Law infirmaries the Committee makes the following observations:

"We have been impressed with the volume and quality of the work carried out by the able infirmary officers whom we have seen, and it seems unfortunate that the abundant and varied clinical material in these institutions should be hardly used at all in the training of medical students. Further, we are informed that during the winter months there are, on an average, over 20,000 vacant beds for sick persons in Poor Law institutions, and that during the summer months the number increases to over 30,000; and it is very desirable that these vacant beds, many of which are suitable for general use, should, if possible, be used for reducing the long waiting lists at the voluntary hospitals. In a few instances the voluntary and Poor Law hospitals do to some extent work together. At Paddington arrangements have been made by which members of the staff of St. Mary's Hospital act as part-time officers of the Paddington Infirmary, and the laboratory work required by the infirmary is done at the hospital. At Lambeth the infirmary is visited by members of the staff of Guy's, and patients are sometimes transferred from one institution to the other. At Dudley Road, Birmingham, the guardians have expressed their willingness to allow students from the university to visit the wards. At

Wolverhampton it is proposed that the hospital should take over one of the pavilions of the infirmary (which is not required for Poor Law patients) and use it as an annexe to the hospital. But such instances are rare. It appears to us that it should be possible to make arrangements under which the staff and apparatus of voluntary hospitals should (so far as possible) be available for the treatment of infirmary patients, while the students at the hospital should be allowed to visit the infirmary wards, and the vacant beds at the infirmary should be at the disposal (on proper terms as to payment) of the hospital patients awaiting admission. Such arrangements could best be negotiated through the Voluntary Hospitals Committees when formed, or in London through the King's Fund; and, if statutory authority is required, it should be given."

Suggestions for Economy.

The Committee next suggests various steps which could be taken voluntarily by hospital managers to improve the financial position of the hospitals under their charge.

"With regard to the general expenditure in the hospitals, it has not been possible for us in the time at our disposal to make systematic inquiry. But the striking differences in expenditure between hospitals of like size and character appear to indicate that there is room in some cases for greater economy."

A series of paragraphs deal in turn with reduction of expenditure, uniform accounts, co-operative buying, removal of less serious cases to auxiliary hospitals, systematization of appeals for donations, collections from wage earners and contributions by employers, other contributory schemes—for example, those known as the Oxford and Sussex schemes—payments by patients, and the institution of staff funds.

Oxford and Sussex Schemes.

"The system of weekly contributions has been carried further by the Radcliffe Infirmary and County Hospital at Oxford, which affords an admirable instance both of the benefits of this system and of the advantages of hospital co-ordination. The Radcliffe, which is the only large hospital in the northern part of Oxfordshire and is connected with the medical school of the University, appears to perform the functions both of a 'secondary health centre' and of a 'teaching hospital' as defined in the interim Report of the Consultative Council on the Future Provision of Medical and Allied Services. It takes all the active cases for the Poor Law infirmaries in its district, and has succeeded in linking up with its work the primary and cottage hospitals and (to some extent) the district nursing service within its radius. And it has recently organized a scheme for obtaining weekly contributions, not only from workmen, but from the whole wage-earning population of the towns and villages in its area—and with conspicuous success. . . . We were informed that, although the scheme was only established in September last, there are already 35,000 supporters paying 2d. per week. . . . We are informed that the counties of Wilts and Hants are organizing schemes on somewhat similar lines."

"A method of voluntary insurance, called a Provident Scheme for Hospital Benefits and Additional Medical Services, has been inaugurated by the Sussex hospitals at Brighton, Hove, and Preston, and was described to us by its author, Dr. J. Gordon Dill, senior physician at the Royal Sussex County Hospital. The scheme is confined to persons whose income does not exceed £260 per annum for a single member, £400 per annum for a man and wife without children or a widow with one child, and £500 per annum for a married couple with a family. The subscription for an unmarried person or a widow or widower without children is £1 per annum; married people without children or a widow or widower with one child pay a joint subscription of £1 10s. per annum, and married people with a child or children under 16 or a widow or widower with children under 16 pay a family subscription of £2 per annum. In the case of persons employed at works or factories, the amount is collected as far as possible by weekly deductions from wages. Members are entitled to free consultation and treatment at any of the co-operating hospitals, or, in the case of members unable to leave their beds, at their homes, but subject in the case of country members to payment of half the usual mileage rate from Brighton. The treatment includes ordinary dental treatment, laboratory and x-ray examinations, massage and electrical treatment when required. Urgent cases are admitted to hospital at once and others in their turn, but a member has no precedence over more urgent cases. Of the proceeds of the scheme one-fortieth is reserved for the cost of laboratory work, one-fortieth for x-ray work, one-fortieth for secretarial work, thirty-five-fortieths are divided among the co-operating hospitals on a basis determined according to an estimate of work done, and the remaining two-fortieths are retained until the end of the year and are then distributed among those hospitals which have had the heaviest calls made upon them. Of the sums paid to the hospitals 25 per cent. is placed in a fund which is at the disposal of their medical staff. The scheme is not yet fully established; but Dr. Dill estimates that if 100,000 members can be obtained, the financial problem of the co-operating hospitals will disappear. The main objection taken to the scheme is that it implies a contract on the part of the hospitals to provide such institutional treatment as subscribers may require; and if a large number of

contributors are secured it may be impracticable to provide the necessary beds without largely increasing the hospital accommodation or excluding non-contributors. But the scheme is interesting and well worth careful consideration, and we understand that its adoption in London and elsewhere is being considered."

Payments by Patients.

In regard to payments by patients—a plan already adopted, in one form or another, at a number of voluntary hospitals—the Committee sees no reason why this practice should not be generally followed, provided care is taken that the poor are not excluded from benefits primarily intended for them.

"We were informed that the increase of the weekly collections at Newcastle has not materially interfered with voluntary payments by patients; but this experience may not be general, and it is obvious that if any system of insurance (such as the Sussex scheme) were generally adopted, this source of income would become less productive."

"As to paying wards—that is to say, private wards where patients are received on the terms of paying the whole cost of maintenance and treatment—we doubt whether hospitals can look for any substantial increase of income by the establishment of such wards. Nor is it desirable that they should do so, since wards of this character occupy considerable space, and the experience of other countries goes to show that a hospital which makes a profit on paying patients is tempted to extend its paying wards to the detriment of the poorer patients. But there may be instances in which vacant space may usefully be filled in this way."

Insured Persons.

The suggestion that the cost of maintenance and treatment of insured persons in a voluntary hospital should fall upon the insurance funds appeared to the Committee to rest upon a misconception of the purpose and effect of the Insurance Acts. Medical benefit as defined in the Acts clearly does not include the more advanced treatment normally given in a hospital or the maintenance of an insured person as an in-patient. But while holding that the approved societies are thus not under any obligation to provide the whole cost of maintenance and treatment of their members in hospital, the Committee feels strongly that they do owe the hospitals a large measure of support, and the hope is expressed that the generous example of the National Deposit Friendly Society, in allocating one-third of its available surplus for hospital and nursing services, will be widely followed.

Payments by Public Authorities.

Coming to proposals for aiding the hospitals which would require legislative or executive action, the Committee deals first with the payments now being made by public authorities for services rendered. These fall under the following heads: (1) Pensioners; (2) tuberculous patients; (3) venereal disease; (4) maternity and child welfare; (5) school medical services.

"It has been suggested to us that these payments should be increased in amount. So far as our inquiries have proceeded, we think that the payments made, except in the case of school medical services, are generally reasonable; but there may be exceptions in certain districts. As the cost of treating these cases differs in different localities, we think it best that any negotiations as to the increase in the amount of existing payments should be left to be undertaken by the hospitals or the Voluntary Hospitals Committees when formed; and we therefore make no recommendation as to those payments. . . ."

"A considerable volume of evidence was given in support of a proposal that grants should be made for the training of nurses, who not only receive a practical education in the wards, but at many hospitals are taught by lectures and classes. This proposal was supported by the witnesses called on behalf of the British Medical Association, who pointed out that nurses trained in the hospitals are regularly absorbed by the education authorities or by the general nursing service of the country. We think that grants for this purpose might be considered by the bodies having charge of the funds applicable for technical education."

A further point was made to the Committee by Mr. Bishop Harman in his evidence on behalf of the British Medical Association. He suggested, in effect, that the clinical notes of hospital patients should be collated, that there should be returns from every hospital, and that these should be collected and form part of the data for medical research: what the State is doing, so far as venereal disease is concerned, could and should be done generally. This suggestion is submitted by the Committee for the consideration of the Ministry of Health, and forms one of the recommendations.

Medical Staff Funds.

In connexion with the grants by public authorities the Committee refers to the practice which obtains in some hospitals of carrying a proportion (from 10 per cent. to 20 per cent.) of these grants to a staff fund which is placed at the absolute disposal of the honorary staff.

"In some of these hospitals, as at St. Bartholomew's, at the Royal Infirmary, Manchester, and at the Radcliffe Infirmary, Oxford, the fund has hitherto been applied by the staff to such purposes as the purchase of expensive apparatus or books, and the support of young practitioners taking up special branches of work; but in other cases the fund has been divided among the staff. The practice is supported by the British Medical Association on the ground that patients sent by a public authority are in the position of paying patients and that in the fees paid for such patients the medical practitioner is entitled to share. On the other hand, the honorary staffs of some hospitals are unwilling to share in such a fund; and two distinguished physicians expressed the view that if the medical staffs came to be subsidized to any substantial extent "the bottom would drop out of the voluntary system." It should be remembered also that, although the services of the staff are honorary, they obtain a valuable return in the form of medical and surgical experience and the enhanced reputation which accrues to a member of the visiting staff of a great hospital. If the system of carrying a percentage to a staff fund is confined to cases where the full cost of maintenance and treatment is paid by or on behalf of the patient, not much objection can (we think) be taken to it; but any extension of the practice beyond those limits appears to us endanger the future of the voluntary hospitals."

Further recommendations are that the contributions by employers to hospital funds should be allowed as deductions from profits for income tax purposes; that hospitals be authorized to claim repayment of income tax when payment of a legacy is delayed for more than a year; and that legacy and succession duty on testamentary gifts be remitted.

Temporary Grants.

The question is then asked whether the new sources of income now being opened and the relief recommended in previous paragraphs will enable the voluntary hospitals to attain a stable financial position.

"We think they will; but the process must take some little time, and unless some temporary financial help is provided without delay from public funds some of them are likely to collapse. After most carefully considering the amount required, we recommend that Parliament be asked to sanction an immediate grant of £1,000,000 to be expended in assistance to such voluntary hospitals as are in need of it. The administration of the grant would be entrusted to the Hospitals Commission on the terms set forth above. This grant, if sanctioned by Parliament, should be looked upon, not as a windfall to be divided among all the hospitals or to be distributed equally over the different parts of the country, but as an ambulance fund to be applied at the discretion of the Commission to the relief of actual and pressing needs. . . ."

"It is probable that the grant suggested for 1921 will not of itself be sufficient to enable the hospitals to tide over the crisis, and that a further grant (possibly of less amount) will be required in 1922. But we think that it should be made clear that Parliament will not consider itself under any obligation, express or implied, to continue the grant beyond the latter year, and that the responsibility for maintaining any voluntary hospital after that time will rest wholly upon those who have the charge of the institution. We have every confidence that if the assistance recommended is given by the Exchequer it will be within the power of those having control of our hospitals, by means of economy in management and energy in interesting the public in their work, to maintain that voluntary system of which we are justly proud."

Lastly, the Committee recommends that the Hospitals Commission be authorized during a period of two years from this time to recommend grants for the extension or improvement of hospital accommodation.

"Any such grant to be subject to a contribution of not less amount being hereafter made from other sources, and no such grant to be recommended by the Commission except after consultation with the Voluntary Hospitals Committee of the area, and on that Committee being satisfied that full provision has been made for meeting any increase in yearly expenditure which may be consequent upon the extension or improvement. We estimate that a sum of £250,000 may be required for this purpose in the financial year 1921-22."

The report is signed by the Chairman and the other five members of the Committee—Lord Linlithgow, Sir C. Hyde, Sir W. B. Peat, Mr. V. Hartshorn, and Mr. R. C. Norman. Besides Mr. Bishop Harman, Dr. H. G. Dain, Dr. J. R. Drever, Mr. W. McAdam Eccles, and Mr. A. E. Morison gave evidence on behalf of the British Medical Association.

British Medical Journal.

SATURDAY, JUNE 18TH, 1921.

THE VOLUNTARY HOSPITALS COMMITTEE.

THE Committee on Voluntary Hospitals, appointed by the Minister of Health last January, under the presidency of Viscount Cave, to consider the present financial position of the hospitals in Great Britain and "to make recommendations as to any action which should be taken to assist them," is to be congratulated upon the expedition with which it has performed the work of the inquiry committed to it. Speed has not entailed a loss of efficiency, for a better balanced report of a Government Committee it would be hard to find. There is evidence of a very thorough inquiry, and a complete grasp of the complex problem involved. Moreover, the recommendations made are of such a character as we feel assured will commend them to every section of national opinion, even though they involve public expenditure—a serious matter in these days of high taxation.

The report shows what a great work is done by the voluntary hospitals, and at what a singularly low cost. The contrast drawn between this economy of private effort in hospital management and the cost of State or municipal effort is most striking. To acknowledge the truth of this is not to disparage State effort; the difference is now known to arise from the very nature of things. People of every status in life—poor folk, workpeople, business men, people of leisure, and physicians and surgeons alike—will do for a voluntary concern what they would not dream of doing, and, indeed, what they could not be advised to do, for a State or municipal concern. This willingness to work freely for a voluntary institution is due to the fact that there is a sense of possession of a share in it, which cannot be felt for a huge State machine; and it is particularly true of a hospital, which makes a strong appeal to the best instincts of all who have any bowels of compassion. We have read no more striking commentary on the different feelings entertained for voluntary and State hospitals than the citation (on page 10 of the report) from the evidence of Sir Anthony Bowlby, who said "There is the active sympathy and co-operation of the whole of the populace of this country with hospitals and hospital treatment. The subscribers, and their friends, are in constant touch with the hospitals; ladies visit them; there are ladies' committees and visiting committees; all sorts of opportunities to help poor patients, whether it be as regards clothing, instruments, or convalescent homes. All that, of course, is entirely lacking in the hospitals on the Continent, where there is no such help at all. There is no inter-communication; the hospitals are practically closed places, into which nobody goes except the people who are authorized." Such a commentary as this coincides with the opinion of those acquainted with the facts; it is in itself sufficient to warrant the most strenuous efforts to retain a system which is so purely British and so rooted in the very genius of our people.

From the standpoint of economy, or from that of sentiment, in whichever way the problem be viewed, from the extreme of hard shell matter of fact to the other extreme of human sympathy, the voluntary

hospital system is easily first. As a system it may be called illogical, much less defensible on that ground than a complete and unified State provision; but even in its failure in logic it is logical, for it conforms to human nature—at least to British human nature. Faults there are in the system; these are frankly owned to in the report. Voluntary effort in its beginnings was sporadic. It burst out here and there with intense energy. Pity is moved, and expression is given thereto in the practical fashion of the good Samaritan. It chanced that pity is aroused on the road to Jericho, and there the effort is made, without reference to the road to Damascus. The time has come when sporadic and unequal efforts must be stabilized and correlated, and the recommendation of the Committee that there should be closer working between the hospitals is well timed, and will receive the support of the medical profession. The experience of such methods gained in London, through the action of King Edward's Hospital Fund, proves that there need be no drag on the wheels of progress or wet blanket on the flame of enthusiasm.

The first recommendation of the Committee is that there should be a central Hospitals Commission for Great Britain, formed on the lines of the University Grants Committee. This is in accordance with the plan advocated by the Representative Body of the British Medical Association. The first duty of this central Hospitals Commission would be the administration of the temporary grants recommended, but it would be available for other purposes. The constitution suggested for it would give suitable representation of the medical profession, but we should need to be assured that a like representation would be secured for the profession on the local or county committees. The Branches and Divisions of the British Medical Association would be able and willing to help these local committees, for they have the means of finding the most capable practitioners for the work, as was shown by the methods adopted to man the Local Medical War Committees.

On the several items of the financial recommendations the most pertinent comment is that most, if not all, the suggested reliefs are debts owing to the hospitals. During the war the Government departments responsible for sending sick and wounded into the voluntary hospitals proved most hard-fisted paymasters. They sublet their work to the hospitals on terms that left the London hospitals alone with a loss of over half a million sterling! The National Insurance scheme would have been a hopeless failure medically and financially had it not been for the voluntary hospitals; without these the weight of sickness benefit alone would have crushed it.

In an interim report published last March the Committee recommended as a pressing matter that the schemes to be approved for the distribution of the surplus disclosed at the quinquennial valuation of approved societies under the National Insurance Acts should provide for the application of a substantial part of that surplus in making contributions towards the cost of the maintenance of members of the societies in hospitals. So far as we are aware no society, with the honourable exception of the National Deposit Friendly Society, has at present acted upon this recommendation. The insurance companies have saved money in workmen's compensation, and made profits, on the work of the hospitals, but have not moved one finger to ease the heavy burdens of the hospitals. Municipal authorities have turned to the hospitals for help and got it. Education authorities have used the hospital machinery at inequitable rates. The voluntary hospitals have sown good seed in the

training of a succession of nurses of the sick, and the nation and its services have reaped the increase but forgotten to return a tithe to the diligent producer. These are debts to the hospitals. They should be paid. And they can be paid without endangering that essential feature of the voluntary system—free and independent management.

On the matter of relief to the hospitals on rates, income tax, death duties, and the like, we need not comment, save to remark that a wise liberality with regard to these claims has in other countries attracted money to voluntary effort, to the great saving in national expenditure. The Committee has examined the contribution schemes for hospital support: the workshop contributory schemes in industrial areas, and the Oxford and Sussex schemes come under favourable review. Some of these are well established, and may be expected to develop still greater ability; others, such as the modified Sussex scheme which is under consideration for London, are planned so as to be an insurance for hospital benefit, and raise far-reaching issues. So far, these schemes are in their infancy; the response of the people is yet to be seen.

The service of the medical staffs to the voluntary hospitals is commented upon in more than one part of the report; its value, its assiduity, and free character, are recognized, and the report contains what is, we believe, the first lay commentary on the "Medical Staff Fund Scheme"—the scheme of the British Medical Association for carrying a proportion of the grants for State and municipal patients to a staff fund which is placed at the absolute disposal of the honorary medical and surgical staff. The Committee's opinion is that "if the system of carrying a percentage of a staff fund is confined to cases where the full cost of maintenance and treatment is paid by or on behalf of the patient, not much objection can (we think) be taken to it; but any extension of the practice beyond those limits appears to us to endanger the future of the voluntary hospitals."

Of Poor Law infirmaries the Committee says that while it has been impressed with the volume and quality of the work carried out by infirmary officers, it is unfortunate that the abundant and varied clinical material in these institutions should hardly be used at all in the training of medical students. The estimates that during the winter months there are, on an average, over 20,000 vacant beds, and during the summer months over 30,000, are accepted, and the opinion is expressed that many of the vacant beds are suitable for general use and should be used for reducing the long waiting lists of the voluntary hospitals. The Committee goes on to suggest that one of the duties of a local Voluntary Hospital Committee should be to make arrangements under which the staff and apparatus of voluntary hospitals should be available for the treatment of infirmary patients, that students should be allowed to visit the infirmary wards, and that vacant beds at the infirmary should be at the disposal, on proper terms as to payment, of hospital patients awaiting admission.

We have summarized the report elsewhere in our columns this week. Nevertheless we would urge members of the profession to read the report in its entirety. It can be obtained through any bookseller for 4d. It is worth reading.

Finally, we would suggest to the powers that be, Parliament and the Cabinet, that what they would do they should do quickly: there is salvage to be made. The proposed temporary grant is not a dole but the payment of an overdue debt. Paid now, it will free the voluntary hospitals from a debt that is dragging

them down like a millstone about the neck and threatens to drown them. Freed from that, they, their executives, supporters and well-wishers will regain a buoyancy which will draw into their wake a new generation of supporters.

OPERATIONS FOR GENITAL PROLAPSE.

THE British Congress of Obstetrics and Gynaecology, held at Birmingham on June 3rd and 4th, a report of which is published in our present issue, was, from more than one point of view, an event of great importance to obstetricians and gynaecologists. The Congress was the first which embraced all the British obstetrical and gynaecological societies, and its success, viewed from every standpoint, was such that it is practically certain to be the first of an annual series.

The chief topic discussed—namely, "The end-results of plastic vaginal operations for genital prolapse"—is one of the greatest importance to all gynaecologists, as well as to the general practitioner who will sooner or later be called upon to advise patients with regard to operative treatment. It is therefore well to have an authoritative pronouncement from such a representative body of gynaecologists as those who took part in the discussion regarding the relative values of the vaginal and the abdominal methods of treatment. At the outset it may be said that a motion had been put down to the effect that "this meeting condemns the use of abdominal operations as unnecessary in the treatment of genital prolapse," but it was felt by a majority of the large assembly present that such a motion would, to a greater or less extent, interfere with freedom of debate, and consequently it was withdrawn before the discussion started. We cannot therefore record a definite pronouncement but only a general impression regarding the trend of opinion, and this will be referred to hereafter.

The three opening papers, by Dr. W. E. Fothergill, Dr. Lacey, and Professor Donald, were commendably brief and lucid. Professor Briggs of Liverpool was in the chair, and by his judicious enforcement of a rigid limit of ten minutes to the subsequent speeches it was possible to obtain within the short space of three hours a kaleidoscopic representation of the views of a large number of the leading gynaecologists of Great Britain. It is important to note, in the first place, that the results of the plastic operation given by Drs. Fothergill and Lacey pertained to cases operated upon during the years of war 1914-15-16, when it would naturally be expected that, owing to stress of work and to the fact that sometimes the actual operations had to be performed by relatively inexperienced surgeons, the after-results of operations would not be the best obtainable under more ideal conditions. In the second place, the patients were women of the working classes, employed in cotton mills or engaged in other laborious occupations, and therefore under the necessity of returning to work after the shortest possible period of convalescence. Taking these two facts into consideration, as well as the fact that no ease was included which merely required perineorrhaphy, Dr. Fothergill's 97½ per cent. of cures and the 87 per cent. of cures in the cases followed up by Dr. Lacey speak for themselves. Furthermore, when Dr. Lacey's results are examined more closely the 87 per cent. of cures becomes in reality much higher. Thus out of the 521 replies received, 455, or 87 per cent., answered the question, "Does the womb keep up well now?" with an

emphatic "Yes." Of the remaining 66, 29 were examined, and if 2 cases of hypertrophic elongation of the cervix are excluded, in both of which amputation should have been carried out at the time of operation, only 5 cases remain in which any anatomical abnormality could be discovered. Assuming that the same proportion of anatomical cures would have been found in the whole 66 had they attended for examination, we seem justified in concluding that only in 11 cases, or about 3 per cent., was the operation a failure. A study of the causes of failure in the 3 per cent. shows that, owing to the presence of such conditions as chronic bronchitis, certainly no better results could have been obtained had ventrofixation been done in addition to the vaginal plastic operation, and it goes without saying that ventrofixation *without* reconstruction of the damaged pelvic floor by the vaginal method must have resulted in a much smaller proportion of cures, whether symptomatic or anatomical.

A consideration of the views of those who took part in the subsequent discussion shows very definitely the almost unanimous opinion to be that in a very large proportion of cases, say 97 or 98 per cent., operation by the vaginal route was sufficient, and intervention by the abdominal route unnecessary and undesirable, increasing the risk and discomfort to which the patient was exposed. In a few cases—especially those in which complications existed, such as adhesions in a retroverted uterus, and perhaps also in cases of congenital prolapse in nulliparae, where all the supporting structures are loose and ill nourished—better results could perhaps be obtained by combining the abdominal and vaginal operations. It is, however, evident that such complications as adhesions and diseased ovaries and tubes are not prolapse at all, and may not even be complications of it; even Dr. Fothergill and his most ardent supporters admit the necessity for abdominal operation with a view to dealing with such conditions.

Professor Donald described the stages by which the present perfected plastic vaginal operations were evolved from the crude methods in use in Edinburgh in the early eighties, when all that was aimed at was so to repair the damaged tissues as to enable the patient to retain a pessary—an evolution in which Professor Donald himself has played a main and distinguished part. This is a record of which British gynaecologists in general, and those of the Manchester school in particular, have good reason to be proud.

PROFESSIONAL SECRECY IN COURTS OF LAW.

IN a case heard before Mr. Justice Horridge in the Divorce Court on June 9th the question of venereal disease arose, and counsel for the husband called Dr. John Elliott of Chester, who had treated the wife. Mr. Barrington Ward, K.C., raised the question whether Dr. Elliott was bound to give evidence. The judge asked whether any authority could be shown for counsel being heard merely on behalf of a witness. Mr. Ward replied in the negative, whereupon the judge declined to hear counsel. Dr. Elliott on entering the box asked the judge to exempt him from giving evidence with regard to venereal disease. Dr. Elliott said that he and other medical men had undertaken duties at the clinic on the distinct understanding that professional secrecy as to what happened there would be observed. The judge asked whether the witness could show any statute which upheld that contention. Dr. Elliott referred to Article II (2) of the Public Health Venereal Disease Regulations of the Ministry of Health, which provided that "all information obtained in regard to any person treated under a scheme approved in pursuance of this Article shall be regarded as confidential." The judge said the Ministry

had no power affecting the jurisdiction of the courts: doctors were subject to the orders of the court and must disclose what they knew. Dr. Elliott, while not contesting the ruling, observed that he was placed in a painful position. The Judge retorted: "I cannot see any painful position about it. You are bound to observe the regulations not to disclose voluntarily information you have obtained; but, so far as giving information which you are bound to give in assisting the administration of justice, it is your duty to give it." Dr. Elliott said: "We do not undertake not to disclose voluntarily, but not to disclose at all. It is one of the tenets of the medical profession that confidence must obtain between doctors and patients." The Judge: "But it is not an unfair obligation on doctors to assist in the administration of justice." Dr. Elliott said: "There is another point—that is, the effect of not keeping these proceedings secret." The Judge: "I have nothing to do with that." Dr. Elliott: "Very well, I have nothing further to say. I must bow to your ruling and give evidence." It would appear therefore that, unless Parliament interferes, the undertaking given by the Ministry of Health in the Public Health Venereal Disease Regulations, which have been approved by Parliament, has become of no effect. In the course of a letter on the subject Dr. J. S. Manson of Warrington writes: "The analogy between the doctor who knows, and the lawyer who knows, may be incomplete, yet it is sufficient to set up a certain feeling of injustice or inferiority in the medical profession as compared to the legal profession in the matter of professional secrets. This, however, is a minor point compared with the doctor's conception of his duty to his patient. The patient, anxious for his mental and physical welfare, unburdens his soul and submits his body to the examination of the doctor, and he is entitled, even as part of the treatment, that the information so obtained should be kept secret, and, except for the gravest of public reasons, such as the detection of serious crime or the spread of serious epidemic disease, the doctor should not be compelled to divulge. The decision of this conflict between the duty of a perplexed and conscientious doctor to his patient and his duty to the public should not be left in the hands of a single lawyer, however eminent, but should be referred to a small committee of the House of Lords, composed equally of eminent medical men and lawyers, for their decision. If some such scheme as this were adopted, it would soon be found that in actual practice much of the medical evidence now required in unimportant cases could be dispensed with, while the public welfare would be safeguarded by the necessary medical evidence in the serious and important cases."

ACQUIRED IMMUNITY AFTER EXPERIMENTAL MEASLES.

IN a previous communication, noted in the BRITISH MEDICAL JOURNAL (April 2nd, p. 500), Blake and Trask, of the Hospital of the Rockefeller Institute for Medical Research showed that a condition closely resembling measles in man could be induced in monkeys by the intratracheal injection of filtered or unfiltered nasopharyngeal washings from human patients in the prodromal or early eruptive stage of measles. In order to determine whether experimental measles protects, as human measles does, against a second attack, a series of reinoculation experiments¹ have been carried out on monkeys which had recovered from experimental measles. Monkeys were injected intratracheally with material containing the virus of measles, and other monkeys were intravenously injected with whole blood withdrawn from a monkey on the third day of experimental measles. None of these re-injected monkeys showed any evidence of infection with the virus of measles, and, as they were with one exception injected with a strain different from that originally employed, it seems to follow that the immunity conferred by experi-

¹ F. G. Blake, M.D., and J. D. Trask, jun., M.D., *Journ. Exper. Med.*, Baltimore, 1921, xxxiii, 621-626.

mental measles is, as in man, as efficient against a heterologous as against the homologous strain. Further, this would suggest the probability that all strains of the measles virus are of a homologous strain in as far as their property of stimulating immunity is concerned. As monkeys injected intravenously with the virus remained immune, it appears that the immunity is not solely, if at all, dependent upon a possible barrier offered by the respiratory mucous membrane of a monkey that has recovered from experimental measles.

CATARACT IN IRON WORKERS.

THE fact that cataract is peculiarly liable to develop in glass-workers is well known, and much information on the subject has been published from time to time in our columns. Evidence is now advanced that iron workers are also unduly liable to cataract. Three papers on the subject are published in the *British Journal of Ophthalmology* for May, 1921. Cridland, of Wolverhampton, deals with cataract in puddlers, among whom the cases are comparatively few. He points out that the number of puddlers is by no means large, and is likely to decrease in the future, as steel replaces puddled iron. His contribution adds a few details to the well-known paper which he published on this subject in 1915. St. Clair Roberts has collected notes on cases of cataract occurring in chain-makers at Dudley. In all he found a posterior polar and cortical opacity very similar to that described in glass-blowers. In describing the method of chainmaking by hand, he states that machines for making chains have not proved successful, and he tells us that it is a common belief among the workers that the sight should fail between the ages of 50 and 60. In uncomplicated cases there is no associated lesion of the fundus, and the results of operation are good. The most comprehensive of the three papers is that by Healy of Llanelly, who, having previously had experience of bottlemakers' cataract in Sunderland, has produced really valuable statistics of the number of cataract cases occurring in men of 35 years of age and over engaged in the tinplate industry at Llanelly. He also describes the nature of the work at length, and gives details of 209 cases. In his cases the posterior cortical type of opacity often existed in combination with cortical striae. His paper strongly confirms the supposition that it is the infra-red heat rays which are the important ones in the etiology of this condition, for in the tinplate mill the men are not exposed to ultra-violet rays. The atmosphere of the mills is dusty, and the men perspire freely; they are adverse to the wearing of protective goggles, but Healy believes that much might be done by suitable propaganda to overcome this prejudice. This series of papers offers weighty evidence in favour of the suggestion that cataract in iron-workers should be scheduled under the Workmen's Compensation Act, as well as glass-makers' cataract. The Glass-workers' Cataract Committee of the Royal Society has sent a deputation to Llanelly to inquire into Dr. Healy's cases, and there is reason to hope that the Home Office will shortly place these trades upon the schedule. These papers appear to us to be amongst the most important contributions to ophthalmology that have recently been published.

THE APOTHECARY POET.

ON October 29th, 1895, in celebration of the centenary of the birth of Keats, the late Sir William Osler read before the Johns Hopkins Historical Club one of his attractive biographical essays, that on *John Keats, the Apothecary Poet*, and it is appropriate that Sir George Newman, an honorary Freeman of the Apothecaries' Society, should now dedicate to the Master of that City Company a charming and critical study of *John Keats, Apothecary and*

Poet, on the centenary of his death. After his mother's death from tuberculosis, Keats, then 15 years old, was apprenticed for five years to a surgeon at Edmonton; but in 1814, more than a year before his time was up, he entered at Guy's Hospital, and in 1816 passed the examination for the Licence of the Apothecaries' Society with credit. After this he never attempted any further medical work, though on one or two occasions, when disheartened with the reception of his literary labours, he toyed with the idea of practice. What influence was exerted by medical training on the poet's mind is an interesting question; although his poems and letters do not reveal any obvious impress from the six years of professional study, it is difficult to believe that his sensitive and responsive mind was unaffected thereby. Thus, though a born lover of nature, he appears in his written remains as a trained and acute observer with a sense of thoroughness, a desire for system, knowledge, and philosophy, a wide sympathy with human suffering, and a fuller comprehension of the part played by health and disease in human affairs. The first of his printed poems, "The Imitation of Spenser," was written at the age of 17, and the last appeared in 1820—a period of eight years; nearly the whole of his output, however, was concentrated into a brilliant space of half that length. "Endymion" saw the light in 1818, and the immortal volume containing "Hyperion," "Lamia," "Isabella," "The Eve of St. Agnes," and the five famous Odes came out in July, 1820, when the author lay dying from tuberculosis, almost certainly contracted when nursing his brother, who had succumbed in 1818. As a boy his genius was awakened by Spenser's "Faerie Queen," and he became an inspired and imaginative interpreter of Nature for her own sake. In forsaking the apothecary's calling he adopted the yet nobler mission of repairing the sorrows and wounds of human lives by the healing power of beauty. Lastly, Keats was a philosopher—and, indeed, in one of his letters boldly describes himself as a philosopher first and a poet afterwards. Sir George Newman sums up Keats's philosophy as follows: "That beauty is truth; that such truth is power; that such power moulds the soul; and that the purpose of the soul is devotion to human service through personality."

THE FATE OF THE LYMPHOCYTES.

THE function and fate of the lymphocytes, which mainly enter the blood by the thoracic duct, are still unsettled. In dogs it has been estimated by P. Rous that the surprising number of 3,300,000 lymphocytes pass into the blood during the twenty-four hours, and that this exceeds the total ever present in the blood at one time. The interesting problem as to the fate of the lymphocytes has been investigated by Bunting and Huston,² of the University of Wisconsin. That the lymphocytes become transformed into other forms of leucocytes, as was once believed, is opposed to modern haematological teaching, and such an explanation of their disappearance need not be further considered. Bunting and Huston's experiments on rabbits showed that a billion or more lymphocytes enter the blood from the thoracic duct in the twenty-four hours, and that in six hours 443,000,000 lymphocytes disappear from the circulation. Stained films may present occasional disintegrating lymphocytes, but further experiments proved that there is not, in this way, the rapid destruction that would be necessary to explain the rate of their disappearance from the blood when their supply is cut off by ligation of the thoracic duct and splenectomy. The remaining possible explanation is that the lymphocytes leave the blood; there is not enough lymphocytic accumulation in the tissues to justify the view that they escape in

¹ *John Keats, Apothecary and Poet*. By Sir George Newman, K.C.B., M.D., D.C.L., Honorary Freeman of the Society of Apothecaries of London. Sholely'd: Printed by T. Bostin, 1921. (11p 3s. 1s.)
² C. H. Bunting and J. Huston, *Journ. Exper. Med.*, Baltimore, 1921, xxxix, 595-600.

this direction, and there is not any evidence of their destruction in the tissues. Microscopic examination of the organs led to the conclusion that the majority of the lymphocytes enter the mucous membrane of the gastro-intestinal tract and pass through into the lumen; this lymphocytic migration takes place not only from the blood but from the lymphoid nodules and patches, which are seen in sections to be delivering lymphocytes to the intestine on one side and to the afferent lymphatics and so *en route* for the thoracic duct on the other side. We therefore appear to be brought to the conclusion that in normal conditions the lymphocyte largely fulfils its function upon the surface of the intestinal mucosa; what this function may be is unknown, but the immunity of the gastro-intestinal mucosa to the countless bacteria and their toxins within its lumen suggests the possibility that the lymphocyte may affix toxins.

BRIGHT'S LESS KNOWN CONTRIBUTIONS TO MEDICINE.

IN an account of the observations other than those on renal disease made by Richard Bright, whose rare ability to observe was fortunately accompanied by admirable descriptive powers, Sir William Hale-White¹ remarks how much better it would have been if some modern authors had transcribed Bright's description of a disease instead of painting the picture themselves. A corresponding plan has often been advocated and adopted as regards sermons, and it is hard to believe that medical writers have not borrowed generously, though not quite verbatim, from such an authority as Bright. To this industrious observer, who sought out the secrets of morbid anatomy and avoided speculation, no trouble was too great to obtain an important necropsy, and for this purpose journeys into the country, in his day very tedious, were cheerfully undertaken. His original observations ranged over a wide field, and included the nervous system, the abdomen, heart-block, and the administration of oxygen. Thus he noted hemiopia in cerebral haemorrhage, described lateral sclerosis of the spinal cord in spastic paraplegia, discussed what was later known as Jacksonian epilepsy, and insisted on the association of chorea and rheumatism. In the Lumleian lectures on disorders of the brain delivered in 1837 he drew attention to the connexion between pericarditis and chorea; the lectures were never published, but, according to the late Sir Samuel Wilks, they contained the first description of a mitral murmur in chorea. Among his numerous contributions on abdominal disease, the most original is that on the occurrence of excessive fat in the faeces of patients with pancreatic carcinoma ulcerating into the duodenum; this was based on three cases, one in a woman aged 21 years only. In the first volume of the *Guy's Hospital Reports* he recorded three cases of acute yellow atrophy of the liver under the title of diffused inflammation of the organ, the present name being applied by Rokitansky in 1842; Bright's account, though not the first, as a reference to Dr. Wickham Legg's classic *Bile, Jaundice, and Biliary Diseases* will show, forms an important landmark in the history of this rare and still rather mysterious disease. It is interesting to learn that Bright anticipated his colleague, Thomas Addison, in so far that he described a case of bronzing of the skin, in which the chief morbid change was disease of the adrenals, but apparently he did not associate the symptoms and the lesion, and so Addison's claim to the discovery of the disease (1855) remains unchallenged. Sir W. Hale-White, who has done so much to throw light on the etiology and clinical picture of simple chronic peritonitis, considers that the first description of this condition was probably that given by Bright. Of a joint work on *The Elements of the Practice of Medicine* one volume only appeared (1839), and this is generally regarded as mainly

the work of Addison; but however this may be, it is remarkable for containing a descriptⁿ, which Howard Kelly seventy years later said "could not be surpassed to-day," of the now common disease which was named appendicitis by the late R. H. Fitz of Boston, U.S.A., in 1886.

MEATLESS DIETS.

THE Vegetarian Society of Manchester has published a pamphlet on vegetarian athletics,¹ written by Mr. Henry Light, who is described as captain for twenty years of the Vegetarian Cycling and Athletic Club. We are glad to see that he is no extremist, but one who recognizes the value of moderation both in opinions and in their expression. He presents first a formidable list of eminent athletes who have given up a meat dietary, and if we can trust the statements about their food intake (and non-scientific people are apt to take but scant account of accuracy without any intention to deceive) there is good testimony as to the value of their present system. But this does not mean that they were strict vegetarians. We believe it is usual to dub their dietary "Vem" (vegetables, eggs, milk, including milk products, for example, cheese). There is no physiological reason why such a diet should be inefficient if taken in properly balanced proportions. Towards the close of the pamphlet the question, What constitutes overfeeding and underfeeding? is raised. To answer such a poser we should have to explain the whole of the principles of nutrition, and that is beyond the scope of this note. Suffice it to say that the amount must depend on the age, size, and activities of each individual. The main factor that causes variation in an average adult is the amount of work he does. The energy-supplying food (fat and carbohydrate) must be proportioned to this. The supply of the protein food which builds tissues and repairs waste is a much more constant figure unless actual growth is in progress. There is no reason why all this should not be supplied by the vegetable world. The usefulness of meat in a dietary depends on what Rubner called the specific dynamic action of protein, and of all proteins those of animal flesh are most efficacious in this direction. But if meat has a specific action, the vegetarians can claim (what they have omitted to do in Mr. Light's article) that plants have also a specific usefulness in supplying to animals those accessory factors known as vitamins, which are indispensable to health and even to life itself.

CHILDREN'S DREAMS.

DREAMS are a source of perennial interest. To the foolish they are omens of profound import. To the wise they are a subject of curiosity and provide room for thought and memory searching in an effort to discover what brought them about. Both wise and simple are influenced by them, for a happy morning waking dream means a fair start for the day, and a nightmare a gloomy breakfast. The dreams of our childhood were as real a matter as the facts of our daily experience, and the meaning of these in the physiology of the child mind, has been studied by Dr. Kimmins, and his results have now been published in a small volume.² His investigations were made upon London elementary school children. His method was to secure their narration individually by the younger children to skilled observers, and to arrange that all dreams of children over 8 years of age were recorded by the dreamers themselves in response to the request, "Write a true and full account of the last dream you can remember. State your age, and also say about how long ago you had the dream you have described." Some 6,000 records were obtained from children aged from 8 to 14 years. He notes that in spite of fear dreams, children in normal health delight in dreaming, and it is an evident pleasure to them

¹ The Vegetarian Society, Manchester. 3d.

² *Children's Dreams*. By C. W. Kimmins, M.A., D.Sc. London: Longmans, Green and Co. 1920. (Cr. 8vo, pp. 134. 5s. net.)

¹ W. Hale-White, *Guy's Hospital Reports*, 1921, lxxi, pp. 145-157.

to talk about and record their dreams. There is also a remarkable power of graphic description which exceeds their ability in ordinary essay writing and is so much in advance of their general standard of achievement that it would appear as though some fresh element had come into play. Dreams are far clearer and more vivid in the calm country than in the noise of London. Change of environment stimulates, and hard mental work increases the tendency to dreams; a stuffy bedroom diminishes their clearness. Persons of well-developed intelligence dream far more frequently than those of low culture. Dreams of motion, falling, flying, are rare under the age of 9 or 10 years; they then increase in frequency up to the age of 17 or 18. Regular institutional life tends to diminish this type of dream; the deaf scarcely ever experience it; febrile states accentuate the liability greatly. The fear dream is very common in quite young children: 25 per cent. were of this nature, and were chiefly of the dread of objectionable men; the fear of animals was more common amongst boys than girls. School activities appeared little in the dreams of children of any age. Air raids figured little, for the last of them occurred seven months before the investigation was made. Domestic occurrences and fairy dreams delight the girls, rarely the boys. The dream ghost has almost vanished. In dreams of adventure, common with boys, the dreamer is usually the hero or heroine. Amongst the blind and deaf dreams are lacking in variety; fear dreams are excessive—fear of animals particularly with the deaf, fear of fire with the blind; to the blind the air raid was a far greater terror than to the normal child, and the impression of it extended to a year after the last raid; for the deaf the raid had no terror. The dreams analysed afford no evidence that a child blind from birth ever sees as a dreamer, but abundant evidence that those who have recently become blind see clearly. It is suggested that a careful study of children's dreams may throw much light on the special interests and desires of the child at different ages, and (especially where dreams of unfulfilled wishes recur persistently) on those elements which are conspicuously lacking in the life of the child, and may seriously interfere with his natural development. Of these, the most obvious are dreams which indicate underfeeding and those which give evidence of stress and strain.

THE CENSUS.

THE Census, which was postponed from Sunday, April 24th, on account of industrial troubles, will be taken on Sunday next, June 19th. The schedule of inquiries contains several new features, the full intention of which cannot be gauged solely by the headings. The new Census paper is certainly more complicated than its predecessors, and many householders will find it troublesome to fill up. For the first time particulars of age are sought in years and months. The reason for this is that some people have filled in the space in round figures, such as twenty, thirty, and forty-five. The fresh demand is for precision. The question about divorce was not asked in previous censuses, but it is felt that statistics are important as touching the care of children, besides which the matter needs to be cleared up, for divorced persons have hitherto returned themselves haphazard as either single or married, and all the marriage figures are made unreliable to this extent. Another column is intended to bring out whether both parents are living, or whether either is dead, in order that accurate information may be obtained as to the number of orphans in the country. The section for details of birthplace and nationality contains alternative columns, the second requiring persons not born in the United Kingdom to state whether they are visitors or residents in this country, and of what nationality if born in a foreign country. Under the heading "Personal Occupation" a person in employment must make clear not only his occupation, but the kind of industry in which he is engaged; the name and address

of the employer are to be added, but they will not be published. In this way it will be ascertained that a carman, for example, is employed by a firm of woollen weavers, and is thus connected with the textile industry. The statistics of occupation will be of value from the standpoint of health by bringing out comparative knowledge of the working conditions of different portions of the community. The particulars as to the industries absorbing service will be more useful for economic purposes. In the alternative column persons out of work are to say so, and thus an aggregate total as to employment will be secured. "Place of Work" forms a new inquiry which has been suggested by the important problems of housing and transport. In the past the Census has shown how many persons dwell in different areas; in future it will show where they work. It is hoped thus to learn the daily tide of movement between people's homes and their places of work, its direction, range, and volume. It is believed that such knowledge will be of use in drawing conclusions as to where houses and continuation schools are most needed. Under the heading "Personal Occupation" information is sought in regard to the education of each child, whether part-time or whole-time. Another section, applying only to married men, widowers, or widows, gives a table for the number and ages of all living children and step-children under 16, whether already enumerated or not—that is to say, whether residing in the family or elsewhere. This is inserted with a view to ascertaining the amount of dependency upon various classes of men and women and various occupations or industries. Yet another provision will furnish an index to housing and therefore to health conditions; the enumerator is to note the number of living rooms occupied by each family. Householders in Wales and Monmouthshire will be asked how many persons in the family are able to speak both English and Welsh, or English only or Welsh only. For the present Census the number of districts is close upon 38,000 for England and Wales, or 2,000 more than at the last Census. In the official pamphlet of instructions an account is given of the process of Census-taking, and of the special machinery provided for punching cards, which, thus prepared, will be manipulated by sorting and counting machines for various purposes. The sorting machines are capable of distributing cards into ten receptacles at the rate of 15,000 to 20,000 an hour. Lastly, we may note that the object of the Census is thus defined: it is "to obtain reliable figures of the population of the country, showing how that population is made up, that is to say, of what sorts and conditions of people it is composed and how it is distributed through the local subdivisions."

COLONEL THOMAS SINCLAIR, C.B., Professor of Surgery in Queen's College, Belfast, is among the twenty-four members elected to the Senate of the Parliament of Northern Ireland; and Sir Thomas Joseph Stafford, Bt., C.B., F.R.C.S.I., Deputy Lieutenant and late Medical Commissioner, Local Government Board, Ireland, is elected to the Senate for the Southern Parliament.

REPRESENTATIVES of the Rockefeller Foundation are at present in this country to discuss the extension of the Foundation's activities in the investigation of tropical parasitic diseases. Hitherto the Foundation has been concerned chiefly with ankylostomiasis, but it is intended to take up other subjects, and the British Colonial Office has promised every facility. Meanwhile, Dr. Victor G. Heiser, one of the representatives, is proceeding at once to India with the view of studying the prevalence of ankylostomiasis there. The other representatives are Mr. George E. Vincent, President of the Foundation, and Dr. Wickliffe Rose, general director of the International Health Board.

Medical Notes in Parliament.

[FROM OUR PARLIAMENTARY CORRESPONDENT.]

Naval Medical Vote.

IN Committee of Supply on Naval Estimates, on June 8th, a resolution was reported for a sum not exceeding £720,500, to defray the expense of medical services, including the cost of medical establishments at home and abroad, which will fall due before the end of March, 1922.

Commander Bellairs said he understood that the representatives of the army and navy were meeting together under the presidency of the Lord President of the Council. He desired, if possible, that Admiralty representatives should meet representatives of the War Office to see whether they could not effect economy by amalgamating the medical arrangements of the army and navy. He found, in the case of Hong Kong, that the military hospital there had accommodation for 166 patients, and the maximum number accommodated was 64, showing a surplus accommodation of 102. The minimum number of patients accommodated was 20, which gave a surplus of 146. Similar figures were shown in connexion with the naval hospital, which had accommodation for 135 patients, while the maximum number accommodated was 97 and the minimum 55. The Yokohama Naval Hospital, also on that station, was closed all through the war and right up to 1920, and it had now been reopened. He urged a thoroughgoing inquiry to prevent overlapping between the two services. There was no difference between the body of a sailor and the body of a soldier so far as medicine was concerned. He believed that the House would be shocked if it were to investigate the number of medical men, say, on the China station, and the number of men whom they had to treat. There were also convalescent barracks at Hong Kong for the military.

Sir Godfrey Collins supported the appeal made by the previous speaker, drawing attention to the case of Malak, where the naval and military had separate establishments side by side. He thought that if the army and navy had combined hospital accommodation it would be to the advantage of the services and the taxpayers. He asked, further, why the Admiralty had refused to adopt the recommendation of the Select Committee on National Expenditure to present their accounts to the House of Commons in the modern method. The War Office had accepted that recommendation, and their accounts revealed the cost of patients in every hospital under the War Office, whereas it was impossible to find, from the Naval Estimates, whether the medical establishments of the latter department were efficiently managed.

Mr. Amery, in reply, said the suggestion for amalgamating naval and military hospital work at certain stations abroad was one that naturally at first sight would appeal to the House. He would certainly look into it, but members would realize that the conditions of naval and military service and discipline and many of the aspects of their organization were so different as to make it not altogether an easy thing to carry out this amalgamation. He imagined, however, that there might be some stations where a military hospital could provide for a certain limited number of naval patients, and *vice versa*. With regard to the particular case of Yokohama, he had not only asked for a close investigation as to the cost of that establishment but also as to the possibility of getting some military establishment elsewhere to take up the patients who went to Yokohama. The War Office was at present the only department which had adopted the new method of accounting. The Admiralty was considering the whole question of their system and had before them a report by a Committee presided over by Colonel Gretton.

The vote was afterwards agreed to.

Coroners' Remuneration Bill.

This measure, which was introduced by Sir Thomas Bramsdon as past President of the Coroners' Society for England and Wales, went on second reading to Grand Committee, where Sir John Baird, on behalf of the Government, promised that if the bill was proceeded with, amendments should be made to secure a revision, and not merely an increase, of the salaries of coroners. On June 10th the bill came on report before the House of Commons, when a number of changes were proposed.

Sir Thomas Bramsdon explained that coroners for counties were paid by salary which was arranged by quinquennial valuation under the Act of 1860. Coroners for boroughs were paid by fees—£1 6s. 8d. for each inquest held; that was fixed by statute, the last increase having been made as far back as 1837. A borough coroner thus got nothing unless he actually held an inquest, whatever inquiries of a preliminary kind he might make; if an inquest lasted three or four days his fee was still limited to £1 6s. 8d. No alteration could be made while the law remained as at present. The legislation now proposed was intended to be temporary. A strong Departmental Committee, appointed in 1909, had recommended a revision in the pay of coroners. Sir Thomas Bramsdon added that borough coroners had no allowances; the sum of £1 6s. 8d. included clerk's fees, postages, and other incidental expenses.

Sir John Baird, in explaining the attitude of the Government,

said it was felt that coroners had a claim to consideration. As regards borough coroners, he agreed that what was adequate in 1837 could not be deemed so to-day. As regards county coroners, he pointed out that under the statute by which the quinquennial valuation takes place, the authorities have no power to consider higher cost of living, travelling, and other expenses, but had to revise solely in reference to the number of inquests held. It was now intended that all relevant matters should be taken into account.

The bill as it came down from Committee proposed that local authorities should proceed to revise the rates of salaries or fees payable to coroners, or, in other words, that an obligation should be imposed, and on this Sir Frederick Banbury moved an amendment to alter the words "shall" to "may," and this was carried by 74 votes to 49. Later he carried the deletion of a part of a subsection of the first clause, which provided that the Home Secretary should fix salary or fees if the authority and coroner failed to agree. Another provision in the bill that the fees should be revised so as to be increased by not less than 50 per cent. was consequently struck out, and the measure was afterwards given its third reading as a permissive bill, the real effect being that if it becomes a statute it will remove the provisions at present existing against the revision of fees or salaries by local authorities.

The Dentists Bill.

Through the unexpected lapse of other business, the Dentists Bill was taken on report in the House of Commons on June 13th.

Sir Alfred Mond (Minister of Health), meeting an objection by Colonel Wedgwood, pointed out that it was only on the understanding that this was a more or less agreed measure that the Government had adopted it; that there had been fairly full discussion in Grand Committee; and that if any member who had not put down notice of amendment on report (though there had been time) made a case for one, it could be put forward in another place.

Colonel Wedgwood, on the first clause, moved the adjournment. The report of the Departmental Committee upon which the bill was founded included, he said, a great deal more than a proposal to place dentists in the same category as doctors—that is, as a closed corporation. There were recommendations for a free dental service, and for some form of scholarship to enable children of the working class to become practitioners. Mr. Seddon, supporting the appeal of the Minister of Health, spoke of the excellent spirit manifested upstairs; contradicting Colonel Wedgwood's assertion that passing the examination would cost £1,000, he said there were thousands of dental mechanics who were making provision to meet the examination. The adjournment motion was negatived.

On Clause 3, on the subsection as to the right of persons who had attained the age of 23 before the commencement of the Act to pass "the prescribed examination within ten years from that date," Colonel Wedgwood proposed to alter "the prescribed" to "a modified," his object being to help the dental mechanics. Sir Alfred Mond replied that "a modified" meant nothing, whereas the word "prescribed" meant that the examination was going to be specially prepared to meet the needs of the occasion. It would be prepared by the Dental Board; all the different kinds of dentists would be represented on the Board, and there would be other members as well. The amendment was negatived. Lieut.-Commander Kenworthy moved to omit the subsection in Clause 16 to apply the bill to Ireland, holding that for Ireland this was a domestic matter and might be left to Irish parliaments or "whatever they might end by having in that country." Sir Alfred Mond said that if Ireland did not want the benefit of this bill, he had no doubt that its people could get rid of it at some future date. If Ireland were excluded, a dentist practising there would be unable to come over and practise in England or Scotland. Asked what would happen to the American dentist, the Minister said that any American dentist holding degrees similar to an English dentist could of course practise in this country. The amendment was withdrawn.

On the motion for the third reading of the bill Colonel Wedgwood moved its rejection, as a protest against the way the matter had been approached that night. Members seemed to look at the measure, he said, as one merely affecting dentists and dental practitioners. The question, he submitted, should be whether there would be a better dental service, and whether too much would be paid for getting it. He was not certain that giving any body of people a close monopoly was likely to improve the work they did. A higher standard might be got by a stiff examination, but the cost of training might exclude a certain amount of intelligence in the country which might otherwise come into the service. The bill might raise the practice of dentistry, but the other side to the question was that it would raise prices. Every dental practitioner who got on the register would have to fall in with a scale of fees given to dentists on the register. Nearly every colliery village he knew had its dental practitioner. They did not do their work very well, but they were cheap. The Departmental Committee had tried to balance the coming advance in fees by recommending the establishment of a Public Dental Service; but that idea had not been taken in the bill. He regretted also the dropping of the Committee's proposal for scholarships. The part of the report which would raise the cost to the public had been adopted; the other two parts which

would have kept down the price and enabled the sons of working-class people to become dentists had been rejected.

Sir A. Mond, in reply, urged that the bill was for the benefit of the public. There was nothing new in principle in it. By amending the defect in the Act of 1878 they were endeavouring to bring dentistry, which was an important branch of medical science, up to a higher standard. To do this they were including a large number of men who had not the academic but the practical experience, and liberal provision was made for them. There was nothing in the bill to enable prices to be put up. The law of supply and demand would apply, and the consideration of means. If the bill had been to exclude a large portion of the men practising now and create a scarcity of dentists, there would have been force in Colonel Wedgwood's argument. But practically the same number of dentists would practise.

Mr. Raffan supported the third reading. The proposals as to public dental service and scholarships could not properly be put in the bill as they were administrative matters.

Major Molson also declared himself in favour of the bill in the interests of the public, and remarked that the British Dental Association had behaved very generously in regard to the measure.

The bill was read a third time without division.

Bellahouston Hospital Inquiry.—Mr. Neil McLean, on June 9th, suggested to Mr. Macpherson that the inquiry into the administration of Bellahouston Hospital should be conducted in public. Mr. Macpherson said that, in response to a request for an impartial inquiry, he had appointed a Committee the members of which commanded the respect of all the people in Scotland. In the proceedings the medical sheets of the men might be asked for, and he could not be a party to the public disclosure of such information. Mr. McLean inquired whether the International Union of Ex-Service Men had been refused representation on the Advisory Committee. Mr. Macpherson said he had no information that this body was representative of ex-service men in Glasgow to any great extent. It had been requested to furnish a complete list of its members in Glasgow, but had not done so. He was satisfied that the interests of ex-service men were fully looked after by the twenty-six representatives already serving on the Advisory Committee. If, however, the International Union would satisfy the Regional Director in Scotland as to the strength of its membership, he would reconsider the matter. Mr. McLean submitted that the request for particulars was made on another occasion, and was also in the present instance out of all proportion to the purpose of the inquiry. Mr. Macpherson added that he thought he was entitled to ask the number of members of this union, as representation should be in proportion to membership. But he thought he had met Mr. McLean's point, as three of its members had been present throughout the inquiry.

National Insurance.—In reply to a question by Mr. Thomas Davies, on June 10th, as to an interpretation of a model rule defining the qualifying requirement for sickness or disablement benefit, Sir A. Mond said that under Section 14 (2) of the National Insurance Act, 1911, every approved society was required to have a rule as to the behaviour of members while incapable of work and in receipt of sickness or disablement benefit. The rule in question, which was drawn up with the concurrence of the Advisory Committee, composed of representatives of approved societies of all types, merely set out the restrictions which a society should impose on the activities of a member whom they had already decided to be incapable of work. The Ministry did not lay down any definition of light work, as it rested with each society to interpret its own rules in applying them to any case which might arise.

Discharged Soldiers and Insurance Benefit.—Mr. R. Young asked whether a discharged soldier temporarily unfit for work, and receiving while in hospital 100 per cent. allowance, was entitled to any benefit under the Insurance Act while in hospital. Mr. Parker, for the Ministry of Health, stated that sickness or disablement benefit was not payable to an insured person while he was an inmate of a hospital or similar institution, but the whole or part of the benefit was paid to his dependants, if any, or might be applied towards meeting any expenses for which the insured person might be liable, otherwise than to the hospital, or, with his consent, might be paid to the hospital if it was not maintained out of public funds. So far as the money was not used in any of these ways, it became payable to the insured person on leaving the hospital. Where the insured person was a discharged soldier in receipt of 100 per cent. allowance, the rate of sickness (or disablement) benefit was reduced by 7s. 6d. a week, unless he had been employed for 26 (or 104) weeks since discharge from the army.

London Hospital; the Closing of Wards.—Mr. Charles Edwards asked, on June 9th, whether the attention of the Minister of Health had been called to the closing of certain wards and curtailment of the out-patient department of the London Hospital, and whether he would take any steps to provide adequate facilities for medical treatment for the people of East London. Mr. Parker, for Sir A. Mond, said that no statement could be made until the Government had had the opportunity of considering the report of Lord Cave's committee which was then before them; accommodation for emergency cases was available in the Whitechapel and other infirmaries in East London.

Welsh Board of Health.—Sir A. Mond stated, on June 8th, in answer to Mr. A. T. Davies, that if a vacancy occurred he should be prepared to consider the appointment of a woman to the Welsh Board of Health. At present the Board, which consisted of salaried administrative officers, was sufficient in number for the work to be done.

Indian Army Officers' Pensions.—Colonel Sir C. Yate, on June 7th, asked whether a decision had been reached on the subject of the additional pensions of £100 and £200 a year which it was stated in the India Office Memorandum a year ago would be granted to Indian army officers on the supernumerary list who had held high civil appointments. Mr. Montagu said he hoped to reach a decision shortly, whereupon Sir C. Yate pointed out the long interval since the first announcement.

Hospital Accommodation for Disabled Men.—Viscount Curzon asked, on June 9th, whether the Ministry of Pensions could take up some of the vacant wards in hospitals and so release but accommodation, such as that at Ruskin Park. Mr. Macpherson replied that this hospital was transferred to the Ministry of Pensions by the War Office authorities. It had been fitted with special orthopaedic out-patient arrangements and special sections for the treatment of disabled officers and nurses. It had been found to provide the most convenient and incidentally the most economical centre for treating the large body of the disabled in that district.

NORTH EUROPEAN CONFERENCE ON VENEREAL DISEASES.

THE North European Red Cross Conference on Venereal Diseases, of which a preliminary note appeared in the JOURNAL of May 21st, 1921 (p. 749), was held from May 20th to 25th at Copenhagen. We have received from the National Council for Combating Venereal Diseases a copy of the following series of resolutions adopted by the Conference:

This Conference, having considered the general measures for the combating of venereal diseases which have been adopted by the participating countries, is unanimously of opinion, so far as the experience of the countries represented is concerned:

1. That the provision, by responsible health authorities, of adequate facilities for diagnosis and treatment on lines which ensure that the greatest possible number of infected persons is rendered non-infective, is a measure of prime importance to the reduction of venereal diseases. The urgent necessity of commencing treatment at the earliest possible moment should be emphasized. It is suggested that the above facilities should be provided free of cost to the patient where they are otherwise unlikely to be utilized to the fullest extent.
2. That the questions of compulsory notification and of compulsory treatment, being dependent on the experience, resources, and psychology of the people concerned in each country, must be decided by individual nations.
3. That instruction, theoretical and practical, in the recognition of venereal diseases, particularly in their earliest manifestations, and in their treatment, should form a part of the curriculum of every medical student, and that satisfaction of a test of proficiency in this subject should be a condition of every medical qualification.
4. That provision should be made at suitable treatment centres for such instruction of medical practitioners in the diagnosis and treatment of venereal diseases as will enable them to recognize these disabilities promptly and secure their adequate treatment.
5. That regulation and official toleration of professional prostitution has been found to be medically useless as a check on the spread of venereal diseases and may even prove positively harmful, tending as they do to give official sanction to a vicious traffic.
6. That the provision of "hostels" and rescue homes for the temporary care of girls suffering from venereal disease is a valuable means of preventing the spread of venereal diseases.
7. That the provision of opportunities for wholesome entertainment and recreation is an important factor in reducing the temptation to exposure to venereal infections.
8. That enlightenment of the general public on lines which are best calculated to minimize exposure to infection and emphasize the necessity of thorough treatment is an essential part of any scheme for the combating of venereal diseases. Instruction should particularly be addressed to parents and teachers in such a form as will enable them to give clear information on the reproduction of life and impress on adolescents the importance of individual responsibility to future generations. In the training of teachers special courses on these subjects should be provided.

England and Wales.

WELSH NATIONAL SCHOOL OF MEDICINE.

THE installation of H.R.H. The Prince of Wales as Chancellor of the University of Wales, at Cardiff, on June 8th, was an important event in the history of the Principality; later in the day the Chancellor laid the foundation stone of the department of Public Health and Preventive Medicine, to be erected at a cost of £60,000—the gift of Sir William James Thomas, to whose princely generosity the University already owed its Physiological Block, which was opened on the same occasion.

A number of honorary degrees were conferred by the Chancellor, amongst the distinguished recipients being Lord Haldane and Mr. Arthur James Balfour. The Prince delivered an admirable inaugural address as Chancellor, in the course of which he laid great emphasis upon the importance of laboratory accommodation and research work. There is a vast field for research in the important industrial area around Cardiff not only into the ordinary problems of disease, but into the health reactions of industrial life in the congested coal-mining districts of the Principality.

The Chair of Preventive Medicine at the Welsh National School of Medicine was endowed by the late Miss Emily Talbot of Margam Abbey, who transferred to the trustees of the college the sum of £37,000 in 4 per cent. Port Talbot Railway debenture stocks, the income of which is to be used for the salary of the Mansel Talbot Professor of Preventive Medicine. The University of Wales is fortunate in having secured the services of Professor Edgar L. Collis as the first occupant of this important department of its School of Medicine. The new Institute of Preventive Medicine as a component part of a complete medical school is remarkable as the first of its kind and far-reaching results are expected from this close association of the curative and preventive branches of medical research.

The new preventive medicine block will adjoin the recently erected physiological block as a part of the complete school of medicine, which is to be established on an island site which includes the old college—now used for the preliminary and intermediate stages of the medical curriculum. The buildings of the School of Medicine, when completed, will be an imposing series of structures in one of the main thoroughfares of the city, and close to the King Edward Hospital, which will provide the clinical facilities for the final studies.

A chair of tuberculosis has been endowed through the munificence of Major David Davies, M.P., and the Llandinam family, and by an arrangement with the Welsh National Memorial Association, Colonel S. Lyle Cummins, C.B., A.M.S., was recently appointed the first David Davies Professor of Tuberculosis.

The Dean of the Medical School, Professor David Hepburn, Professor Graham Brown—the Professor of Physiology—and Professors Collis and Cummins, were presented to the Prince, who afterwards inspected the physiological block with Professor Graham Brown, and showed a close interest in the equipment and research work of the department.

A great deal remains to be done before the scheme for a complete medical school is perfected, but, in the words of the address presented by the university authorities to the Chancellor, it is hoped that "the visit of the Prince will help the leaders of public opinion in South Wales to realize the significance of higher education in regard to national prosperity," and that the other captains of industry will follow the generous examples of the princely donors of the physiological and preventive medicine blocks, in the support of science as applied to the art of medicine and to industry.

A CRITICISM OF THE CHESHIRE TUBERCULOSIS SCHEME.

The tuberculosis scheme of the county of Cheshire has recently been the subject of criticism by the County Local Medical and Panel Committee.

The scheme is designed to provide facilities for treatment and prevention of all forms of tuberculosis affecting all classes of persons within the county, which, for administrative purposes, is divided into four dispensary districts, with one subdistrict. In each of these one or

more dispensaries or branch dispensaries is established; at present fourteen such institutions have been set up. The scheme also proposes to provide sanatorium accommodation for early curable cases and pulmonary hospitals for advanced cases. A sanatorium is now being established at Burntwood to provide seventy beds. It will serve the whole county of Cheshire, including the county boroughs, and also the county borough of Stoke-on-Trent, which is in Staffordshire, as is in fact Burntwood itself. There is also now approaching completion a training or employment colony at Wrenbury. The Cheshire branch of the British Red Cross Society and Order of St. John gave £30,000 to the County Council to help in establishing a colony for fifty cured or arrested male cases. Wrenbury Hall, with 162 acres, was purchased for the purpose. The doctor and matron are already installed, and it is hoped that the place may be opened in a few weeks.

Pulmonary hospitals for advanced cases requiring treatment or isolation are provided in tuberculosis pavilions attached to some of the ordinary isolation hospitals of different Cheshire districts. Arrangements have been made with the general hospitals, infirmaries, and cottage hospitals to provide beds for emergency cases and for surgical cases. Additional beds are retained at the Leasowe Children's Hospital for children affected with non-pulmonary tuberculosis, and the Royal Liverpool Country Hospital at Heswall is also used for the same class of disease. A central laboratory for the examination of sputum and pathological specimens has been equipped in connexion with the central office of the county tuberculosis officer. In addition to this officer the staff consists of four whole-time tuberculosis officers and eight tuberculosis nurses, two in each district working under the direction and supervision of the district tuberculosis officer. In the fifth, the Chester district, arrangements were made to share the services of the city tuberculosis officer, while in the part of the Chester area formed into a subdistrict the duties of the tuberculosis officer are carried out by a part-time officer, who is also Medical Officer of Health for the North-West Cheshire Combined Sanitary District. The chief tuberculosis officer was appointed to act as consultant to the district tuberculosis officers and to practitioners where necessary, and generally to supervise the residential treatment of all cases in institutions. As has already been stated, fourteen dispensaries and branch dispensaries have been established. The work done at a dispensary is defined as follows:

"The function of the dispensary is to act as a receiving centre for all classes of cases, and all kinds of information relative to and affecting tuberculosis in the district; a centre to which cases shall be sent for expert examination and diagnosis; a clearing house where all cases of tuberculosis shall be sorted out, classified, and suitable treatment or procedure determined in each instance; old cases re-examined from time to time as may be necessary, and home treatment supervised."

"Each dispensary district constitutes a complete unit of organization, and is under the control of the district tuberculosis officer, the nurses acting directly under his supervision. The tuberculosis officer examines patients at the dispensaries, makes such recommendations and reports as may be necessary in each case, and also acts as a consultant to the medical practitioners in regard to all cases of tuberculosis occurring within his area. . . ."

"One of the important functions of the dispensary is the examination of 'contacts' with a view to detection of incipient cases of disease at the earliest opportunity and before symptoms have become manifest."

The scheme, we understand, was promulgated in 1915, but for various reasons is only now coming into full working order. It has been watched by general practitioners in the county with interest from the first, and recent developments have induced the Cheshire Local Medical and Panel Committee to address a letter to the Cheshire County Council, suggesting that the tuberculosis dispensaries should be done away with and a simpler, more efficient, and less expensive system substituted.

The letter states that nine-tenths of the matters in question are within the day-to-day experience of general practitioners, who are naturally keen but far from unfriendly critics of the new official measures. The letter goes on to point out that the Committee regards the sanatorium at Burntwood as the central feature of the scheme. The sanatorium and the tuberculosis pavilions attached to certain of the isolation hospitals should have observation beds, to which a person, when his illness was first notified, would be admitted. The case could

there be investigated far more thoroughly than at a dispensary consultation; a temperature chart would, for example, be available, and after a few days, or in some cases weeks, no doubt would remain as to the condition of the patient and the tendency of the disease in his case.

With regard to the proposed consultative function of the dispensaries, the Committee expresses the view that consultations should be with consultants, and that in difficult cases the services of physicians, and in cases of surgical tuberculosis those of surgeons, of hospital standing should be available. The letter continues:

"The dispensaries can never provide a satisfactory consultant service. You cannot attract men of matured hospital experience and standing for the salary that can be offered. You cannot 'grow' such experience in an atmosphere in which the clinical element is too rarefied and the administrative too toxic. It is a product of the hospital. True, individuals may transcend their opportunities; but then the higher paid berths elsewhere soon attract them.

"On the other hand, my Committee holds that the senior medical staff at Burntwood, and also at Wrenbury, should be available for consultation, and that the assistant tuberculosis officers should be transferred to the sanatorium staff on the closure of the dispensaries. The Burntwood staff might possibly have to be increased by an extra doctor if the demand for consultants were to grow."

"The monotony of the life of an isolated institution, the tendency to stagnation, and the lack of stimulus from outside association would all be usefully modified by adding the duties of consultant to those of sanatorium medical officers. Alertness, efficiency, knowledge of the districts from which the patients come, their environment, and status will be gained on the one side; on the other, general practitioners will be brought into useful touch with the work at Burntwood."

The examination of contacts, it is considered, would be more likely to be acceptable if done by the family doctor.

"In the long run," it is said, "that system will prove to give more complete results than the vain attempt to carry out a family inquisition through the dispensary. If there were 500 families to be examined a year, at a guinea a family, the expense would be small compared with the saving of the rents of the dispensaries and of salaries."

On sanitary supervision and the enlistment of voluntary aid the letter makes the following observations:

"Since the inception of the scheme the district medical officer of health and sanitary inspector have regarded the matter of tuberculosis as very largely taken out of their hands; and there has been a tendency for the care of the sanitary environment of a tuberculosis patient to fall between two stools. The information that the Local Health Authority was once again to regard itself as fully responsible for the background in which the life of a consumptive is to be led would reawaken it to its opportunities, and bring into play all the forces of local knowledge and local enthusiasm."

The conclusion is that the dispensary system while it may work well in a city is inappropriate to a great scattered county, and the hope is expressed that the county council, with the advice of its chief tuberculosis officer, whose courtesy and desire to help is acknowledged, will accept the expression of the views of general practitioners contained in the letter. Their proposals, it is pointed out, have at least the merit of being far less expensive than the scheme that holds the field.

LIVERPOOL MEDICAL INSTITUTION: THREE JUBILEES.

A special general meeting of members was held on June 8th, to which ladies were invited, to tender the congratulations of the Institution to Drs. W. Macfie Campbell and John B. Edis and Mr. Rushton Parker on attaining the jubilee year of their membership. Dr. John E. Gemmell (President) was in the chair, and there was a good attendance of medical men and ladies. Owing to indisposition, neither Dr. Campbell nor Dr. Edis was able to be present. At the instance of the Chairman, the resolution that the congratulations of the Institution be tendered to each of the members was proposed and seconded formally by life-long friends of the recipients of the honour. In the case of Dr. W. Macfie Campbell, the resolution was proposed by Dr. T. R. Glynn, ex-President, who called to mind that Dr. Campbell was at one time resident house-surgeon at the Northern Hospital when Dr. Glynn was honorary physician. Afterwards he became leading obstetrician. Dr. Campbell had filled all the posts in the Medical Institution and was an ex-President. In spite of a large practice, his zeal in promoting the interests of the profession was remarkable, and Dr. Glynn expressed the hope

that Dr. Macfie Campbell would still enjoy good health, to which he was glad he was now returning, for many years to come. Mr. Charles H. B. Shears, in seconding the resolution, mentioned that he had been house surgeon at the Northern Hospital under Dr. W. Macfie Campbell, and bore testimony to the kindness and sterling character of his old and respected friend. The President read a letter from a member, who preferred to be anonymous, extolling the high professional standing Dr. Macfie Campbell always took in his relation to his fellow practitioners. A letter from Dr. Macfie Campbell was read by the President, in which he expressed his great regret at not being present to receive the congratulations of the members which he so highly appreciated and for which he tendered his sincere thanks. Dr. Macfie Campbell called to mind events in the history of the Liverpool Medical Institution, and mentioned the circumstances in which the first lady—the late Dr. Lucy Craddock—was admitted a member. The resolution was carried unanimously.

Dr. Charles B. Macalister proposed the resolution of congratulations to Dr. John B. Edis. He came to Liverpool to hold the post of medical missionary, and did much work during the epidemic of typhus raging at that time. Although not a robust man, he not only survived an attack of typhus and of typhoid fever, but built up for himself a large midwifery practice, and had brought into the world some ten thousand babies. He was one of the medical officers attached to the Hospital for Diseases of Women, and during a long and strenuous life continued to take a keen interest in the Liverpool Medical Mission. He was a great cyclist and expert with the camera, and to these recreations he ascribed his good health. Mr. Keith W. Monsarrat seconded the resolution, adding that Dr. Edis was a man held in affectionate regard by all with whom he was brought into contact. The Chairman put the resolution to the meeting, which carried it unanimously.

In proposing the resolution of congratulations to Mr. Rushton Parker, who was present, Mr. Paul gave an interesting account of his earliest recollections of Mr. Parker, whom he first met in 1875. Pathology, then comparatively a young science, was the bond of union between them. Mr. Parker was essentially a scientific surgeon, and this habit of mind was his leading characteristic. Mr. Parker recognized at the very outset the genius of the late Hugh Owen Thomas, and was one of the first in Liverpool to introduce the famous surgeon's methods into his own practice. Mr. Parker was ever sincere, frank and outspoken, witty, and possessed of a keen sense of the foibles of his professional brethren. Mr. Paul felt it an honour to be the proposer of these congratulations, and expressed the hope that Mr. Parker might celebrate his diamond jubilee membership. Dr. Glynn seconded the resolution, emphasizing the characteristic love of truth ever to be found in Mr. Rushton Parker, and incidentally alluded to the many acts of kindness he had shown to many of his professional brethren. Mr. Newbolt supported the resolution, adding an expression of his personal regard for Mr. Parker, not only as a surgeon but as a straightforward fearless man. The motion, on being put from the chair, was carried unanimously, and amid applause Mr. Rushton Parker rose to reply. He expressed his appreciation of the high compliment that the Institution had paid him, and went on to describe his earliest experiences, amusingly sketched incidents that happened to him as a young surgeon, and delighted his hearers with reminiscences of Mr. Stubbs, one of the honorary surgeons to the Royal Infirmary at that time. Mr. Parker alluded to the origin and the growth of the Liverpool Royal Infirmary School of Medicine, now the Medical Faculty of the University of Liverpool, and mentioned some of the characteristics of the lecturers of that time. In thanking the members for their congratulations, he felt he ought to propose a resolution of sympathy with Dr. Macfie Campbell and Dr. John B. Edis for their inability to be present on this occasion, and to express the hope that both would soon recover from their indisposition.

LIVERPOOL CHAIR OF OBSTETRICS.

At a meeting of the Council of the University of Liverpool, held on June 8th, Dr. W. Blair Bell, gynaecological and obstetrical surgeon to the Royal Infirmary, Liverpool, and lecturer in clinical gynaecology in the university, was appointed to the Chair of Obstetrics and Gynaecology, vacant through the resignation of Professor Henry Brigg.

THE LEEDS GENERAL INFIRMARY: RE-ALLOCATION OF BEDS.

The question of the re-allocation of beds throughout the hospital was recently referred to the Faculty for consideration and report, and, although this was by common consent regarded as a highly contentious matter, careful consideration in a spirit of mutual concession has resulted in the presentation to the board of a report which had the merit of coming from the Faculty without a dissident and which was adopted. It is true that effect cannot be given to the re-allocation until the modernization of certain of the wards, which was referred to in this column, has been completed. During the years of the war the division of the beds between the various departments has been modified and obscured by many circumstances. Thus, on the outbreak of the struggle a request came from the War Office for accommodation for 115 wounded soldiers, and this was afterwards increased to 135. A ward which is usually kept as an emergency ward was at once put in commission and the large out-patient waiting hall was converted and used for the accommodation of patients, much of the out-patient work being relegated to temporary centres near the infirmary. In passing, it may be mentioned that 4,918 soldiers from convoys were dealt with in the infirmary, and in this way the pressure on the Second Northern General Hospital was lessened. The admission of soldiers came to an end during 1919, but beginning in 1918 and still continuing there has been a yearly admission of discharged soldiers, who are being sent by some one or other of the authorities acting under the Ministry of Pensions. The figures for 1918, 1919, and 1920 were respectively 346, 353, and 283, and it is hoped that the numbers will dwindle and this call on the infirmary soon disappear, except possibly for a small number of special cases sent for investigation. The buildings of the Second Northern General Hospital are being used for pensioners, and this would appear to make further demands on the infirmary unnecessary, except, perhaps, for very special cases. During the war, also, it was found necessary to close two wards owing to a scarcity of nurses, so that when the new pavilion of the King Edward Memorial wing was opened the number of beds, as compared with pre-war years, was not materially increased. When the wards which it is determined are to be used in the not remote future can be occupied, there will be 432 beds for adults and 99 cots for children, with, in the case of the latter, the prospect of a substantial increase in the form of a semi-open-air ward on the terrace with accommodation for about 20 children. The arrangement of the wards has made it possible to allocate these beds and cots as follows:

	Beds.		Cots.	Total.
	Male.	Female.		
Medical	66	47	33	146
Surgical	135	71	52	258
Ophthalmic	27	17	8	52
Aural	14	12	6	32
Gynaecological	—	23	—	23
Isolation	8	8	—	16
Suspected alcoholism	2	—	—	2
Observation	2	—	—	2

Until such time as provision can be made for those patients who are at present accommodated in the isolation wards it will not be possible to transfer the isolation block to the venereal department, which is regarded as desirable, and which has been decided upon. This re-allocation of beds and cots, which has been the subject of much thought, does away with the mixture of medical and surgical cases in children which prevailed to a certain extent under the old arrangements; it brings the surgical cases nearer to the operating theatres, and leads generally to concentration of charges and convenience of teaching. It is hoped that the scheme will be in full operation by the beginning of next year.

PROVISION FOR TREATMENT OF CHILDREN IN LEEDS.

In the re-allocation of beds and cots above referred to, the need for improved and extended accommodation for children has been kept steadily in mind. It is indeed true that the number of children treated both in the in-patient and the out-patient department of the infirmary is greater than many members of the Leeds public grasp. This it is which leads from time to time to expressions of regret that "there is no children's hospital in Leeds." As a matter of fact no fewer than 1,500 were admitted to the children's wards during the year 1920, and the numbers dealt with in the out-patient department are very great. Until lately the accommodation especially reserved for children has been only 71 cots. In the near future, as has been mentioned above, the number of cots will be increased to 99 with the prospect of some 20 more in the semi-open-air ward, and such a segregation of the children's cots will be secured that the infirmary may be regarded as containing within its walls a fully equipped children's hospital. It is true that there is still in Leeds, appreciable by those who have eyes to see, ears to hear, and hearts to understand, an eloquent and urgent appeal for more accommodation for the treatment of children; but those who are best informed will cordially agree with Mr. Charles Lupton, the treasurer of the infirmary, when he says that the wisest way to meet this is not the provision of a new hospital, but a generous extension of the accommodation, some miles away from the centre of Leeds, for the treatment of those cases which are necessarily of long duration, such as articular and abdominal tuberculosis, and heart disease at that stage in its development when a few months of care may improve the prospect of a useful life and may lessen the likelihood of much suffering. An expensive and highly specialized institution is, indeed, in the first instance necessary for the treatment of such cases as may require difficult operations and careful investigation; when this time has been tided over the patients can be transferred to a place where they can get those things which are their later necessity—namely, good food, fresh air, and kindness. Leeds has been happy in the centralization of its medical charities; it is to be hoped that this will not be disturbed; decentralization would lead to extravagance in management, and it would be bad for the welfare of the patients and injurious to the teaching of the students. Those, therefore, who desire to further the treatment of children in Leeds can best do so by subscribing to the funds of the infirmary, and especially by the endowment of cots. In this respect the Leeds Caledonian Society has set a good example: at its annual dinner last January Dr. T. Wardrop Griffith, the president, was able to hand to Mr. Charles Lupton a cheque for £1,200, which he hoped might in time be increased to £1,500, to enable three cots to be endowed; it was, he said, the result of a collection made among the members of the society.

Scotland.

MEDICAL ADVISER TO PRISON COMMISSIONERS.

The Secretary for Scotland has appointed Harry Rainy, M.D., F.R.C.P.E., Vice-President of the Royal College of Physicians of Edinburgh, to be Medical Adviser to the Prison Commissioners for Scotland, in succession to the late Sir Thomas R. Fraser.

GLASGOW EAR, NOSE, AND THROAT HOSPITAL.

At the annual meeting of the Glasgow Hospital for Diseases of the Ear, Nose, and Throat, which was held on June 8th, Lord Provost Paxton presided and moved approval of the directors' report. In this it was stated that during the past year steps had been taken to organize a committee and to raise funds for the proposed new hospital, and that Lord Weir would act as chairman of this committee. It was hoped that the response to the appeal for funds which was now being made would enable the directors to build the new hospital within the next two years, as at present the accommodation available was greatly overtaxed. Last year 6,008 patients were treated at the hospital, and the number of attendances was 20,339. The building fund now amounts to £11,650.

Correspondence.

THE PURE CLINICIAN.

SIR,—I have read with interest but great uneasiness Sir James Mackenzie's address at St. Mary's Hospital; with uneasiness, for am I not right in assuming that Sir James is leading a new movement which appears to be increasing the distance between the patient and the laboratory, instead of striving for what everyone who has the interests of prevention, early diagnosis, and accurate specific treatment at heart desires—a decrease in the distance until there is a complete liaison?

He states that the diagnosis and prevention of typhoid fever, syphilis, and rabies is entirely the result of accurate clinical observation, while such diseases as malaria had to be handed over to the laboratory worker; yet everyone knows that the accurate diagnosis of all these diseases and their prevention cannot be achieved in the absence of the laboratory. The treatment of syphilis has to be controlled by laboratory tests, that of rabies is entirely dependent on the laboratory, while the treatment of the enterics, which can be aborted or very rapidly cured by laboratory products if the laboratory is properly used for early diagnosis, has, in the hands of the pure clinician, made no advance in specific treatment in the last fifty years.

I quite agree with Sir James as to the importance of prognosis. I always teach the importance of this and urge the perusal of the Registrar-General's returns, for it is from these and these alone that prognosis can properly be judged. Sir James takes measles as an instance for prognosis in cases of antigen (vaccine) therapy. Unfortunately the laboratory has so far failed to diagnose this disease, but measles, as Sir James points out, is of little importance; it has little effect on the general death rate. Let me take, however, two diseases, in one of which—tuberculosis—I am especially interested, and the other—heart disease—in which he is.

Now anyone reading such a book as Riviere's *Early Diagnosis of Tuberculosis of the Lungs* will realize to what very great refinement the interpretation of symptoms produced by the excitation of abnormal and interference with normal reflexes and that of physical signs has reached, and yet by these methods no certain diagnosis can be made, for the enlarged glands at the hilus of the lungs can be produced by many other microbes besides the tubercle bacillus. Only by subcutaneous tuberculin tests, a product of the laboratory, can an accurate diagnosis be made at this stage. Sir James Mackenzie's life work has been the accurate diagnosis of the lesions in hearts damaged by the depredations of microbes, but I have not gathered from his writings that he has been particularly interested in the accurate diagnosis of the microbial cause of the symptoms he has been treating; and yet the prevention of heart disease or of the constant flares-up of infection when it has occurred is entirely dependent on the isolation of the causative organism and the immunization of the patient with it.

The failure to control these and other causes of the highest death rates has been due to the seeking for and cure of the symptoms of the diseases instead of the seeking for and destruction of the microbial causes of them. For this there is no excuse, for the laboratory has made known the causes and furnished us with the means of treatment.—I am, etc.,

Dublin, June 4th.

W. M. CROFTON.

DEFECTS IN TUBERCULOSIS ADMINISTRATION.

SIR,—Efforts have been made in the county of Essex to remove the confusion and friction referred to by "Mixture" in your issue of June 4th (p. 839).

Conferences with the Ministry of Health and local sanitary authorities resulted in the unanimous adoption of the principle of a combined medical service for a specified area, whereby a whole-time medical officer was appointed to undertake the duties of local medical officer of health and assistant county medical officer (including tuberculosis officer, school medical inspector, and inspector of midwives). Salary and expenses are apportioned between the county council and the local sanitary authority on an agreed basis. As local medical officer of health he is directly responsible to the local sanitary authority, and

as assistant county medical officer he reports to the county council, through the county medical officer. There are already three such appointments, the first officer having actually taken up duty on April 1st, 1920.

Essex claims to be the pioneer of this fusion of local health duties, and it has succeeded beyond all expectations in removing hindrances to *progressivo preventivo* and remedial work. There is no overlapping or friction, one medical officer being responsible for safeguarding the health interests, personal as well as environmental, of the community. He receives his own notifications of cases of tuberculosis, keeps his own register, acts upon the cases as tuberculosis officer as well as local medical officer of health, and is further supported by a combined nursing and clinic service built up on the same lines. The same remarks apply to the school medical service.

Briefly, it may be said that unification has brought about a more economical service, increased the efficiency, zeal, and interest of the medical officer, and reduced the number of officials who visit homes by establishing a central health officer. The scheme is now about to be established on a somewhat similar basis in six more sanitary districts with an acreage of 203,934.

In other parts of the county we have endeavoured to overcome the difficulties in regard to the record-keeping and following up of notifications of cases of tuberculosis by asking the local authority to appoint the county council's tuberculosis officer as assistant medical officer of health, but this was secured in only three instances.

I am more than ever satisfied, after twelve months' experience, that the combined scheme outlined above is a foundation on which can be built an efficient and co-ordinated health service in county districts.—I am, etc.,

W. A. HULLOUGH,
County Medical Officer.

Chelmsford, June 11th.

A NEW STUDY OF APHASIA.

SIR,—One or two passages in your important discussion of this subject, no less than one or two passages in the lectures referred to therein, are perhaps a little difficult to some of us.

It is not quite clear what is meant by the "materialism" of the schoolmen which is said to have been swept away by Descartes, or how it is that, as a result of the teaching of Descartes, no one "presumed to correlate directly the activities of the Mind with the life of the brain."

For, in the fifth part of the *Discours*, Descartes himself discusses:

"Quels changements se doivent faire dans le cerveau pour causer la veille, et le sommeil et les songes; comment la lumière, les sons, les odeurs, les goûts, la chaleur et toutes les autres qualités des objets extérieurs y peuvent imprimer diverses idées par l'entremise des sens; comment le faim, la soif et les autres passions intérieures y peuvent aussi envoyer les leurs. . . ."

Descartes goes on clearly to indicate how, on the side of cerebral outgoings, movements of the limbs are produced. Even when he pictures animals as differing from human beings in the absence of controlling and directing faculties, he does not hesitate to correlate human reason with the life of the brain, in the famous passage which, though usually quoted as locating the "soul" in the pineal gland, really anticipates what we now express when we correlate so much of our emotional life with states of the chromaffin system.

Again, the view of language attributed by you to Locke is really that of Descartes. For the latter, speaking of animals as automata, says:

"Jamais elles ne pourraient user de paroles ni d'autres signes en les composant comme nous faisons pour déclarer aux autres nos pensées."

Here is the idea of language as expressive of propositions; and the famous sentence which Talleyrand inverted to form his wicked but obvious epigram.—I am, etc.,

London, W., June 10th.

F. G. CROOKSHANK.

THE PREPARATION OF SCIENTIFIC PAPERS.

SIR,—As Sir James Barr is so gracious as to express, in repeated phrases, his gratitude for my "instructive criticism," I may well be content to leave a decision on any disputed points to the judgement of your readers. Sir James states a limited defence with, if I may say so, excellent temper, and he attempts some amusing though

irrelevant counter-strokes; where, even to his ingenuity, defence is frankly impossible, he, as a prudent controversialist, practises a judicious silence. Had he cultivated the "pool" which he commends to me he might perchance have avoided his blunder relative to the "tower." But here again he shows his disposition to preach rather than to practise. His imagination and good nature credit me with a resolve not expressed in my letter, but if he, too, "intends to get rid of all superfluities," our combined examples will surely not be in vain. It is here that his collection of "a variety of paper fasteners" gives me some concern; so formidable an apparatus suggests a provision for the development of a "verbosity" from which Sir James fondly believes himself at present to be free. He offers me a specimen "fastener," but I would much rather hear he had "scrapped the lot." His opportunity just now would seem to lie in "works" rather than in "words," for after his recent enterprise it is to be feared he will, at least for some time, be ineffective in the pulpit.—I am, etc.,

London, W.1, June 13th.

C. O. HAWTHORNE.

REFRACTION WORK IN CHILDREN.

SIR.—When I was a house-surgeon in an eye hospital I was taught that retinoscopy was an exact science, that there should be no obstacle in determining objectively the actual error of refraction in the eye, and that the difficulty in prescribing glasses lay in deciding which glass was most suitable to the individual needs of the patient. In solving this difficulty in children one relied more on objective than subjective findings, entirely so in the case of illiterates.

Dr. A. E. Larking states that he considers three cases an hour a good average, but continues to the effect that six or more could be done were subjective tests dispensed with. It follows that at least half the time employed over the three cases an hour would be spent on subjective examination. What additional information would these subjective tests yield to aid in arriving at the desired glass? As accommodation has been paralysed, the glass giving the best vision would almost invariably be that which gives full correction. The refractionist by his retinoscopy is already aware of the strength of this lens, so that beyond the vision obtained he has learned nothing fresh. This glass, while giving the best vision, is not necessarily the one to be prescribed.

Again, in the very common error of hypermetropia with or without astigmatism, how is the examiner to estimate the presence or amount of latent hypermetropia, the ciliary muscle being paralysed, without knowledge of the manifest hypermetropia obtained only by a subjective examination made before atropine has been used? Is it wiser to lend a patient ear to the lisping assistance of childhood than to rely upon one's own observations and judgement backed by rules proved by experience to be sound, such as full correction in concomitant strabismus, in low and moderate degrees of astigmatism, in low and moderate degrees of myopia, and the use of Mr. Bishop Harman's chart giving the average necessary correction deduced from the total hypermetropia obtained by retinoscopy?

I have no desire to depreciate the importance of subjective examination, but feel convinced that if one is inclined to give it that prominence which Dr. A. E. Larking appears to regard as its due, it would be more helpful if deferred until the action of atropine had passed off.

Mr. J. Parkinson Higham raises the question of sweated labour, I think pertinently. It would be interesting to learn how many hours at six refractions an hour—that is, how many refractions a day—were expected of Dr. A. E. Larking by the Education Committee he mentions.—I am, etc.,

Barra, N.B., June 2nd.

J. N. M. SUTHERLAND.

SIR.—The emphasis laid on speed in refraction work in children will, I am afraid, tempt many men, especially beginners, to spend less time on their cases. This would be a great misfortune.

A case, without astigmatism, takes but a few minutes, but a beginner will find it very difficult to determine that no astigmatism is present, and should spend time on the point. In severe astigmatic cases, any time up to, say, three-quarters of an hour (beginners more) can often be

spent with advantage. It is wonderful what a small change, say, in the axis of a cylinder, will sometimes effect. Until all such possible changes have been tried, the best possible has not been done. Subjective tests are of great value not only in adults, but in children, and, within the above time limits, it would be true to say that the longer the time spent the better the result, and that more time had better be spent than other than the best possible result obtained.

Any number of cases can be done in an hour. The number actually done will depend on the degree of accuracy attained, the skill of the surgeon, the cases waiting, and most particularly on the proportion of severe cases. In our central eye clinic weeks sometimes pass without a case free from astigmatism, and, after having done some 7,000 refractions, I find time well spent at about three cases an hour.

To illustrate the importance of the best possible, perhaps I may be pardoned for giving this instance: A youth was brought to me privately, wearing glasses prescribed, possibly in a hurry, by a public institution. He stated that he had just been dismissed from work owing to his defective sight. A full hour spent on the case—one of severe myopic astigmatism—resulted in new glasses giving a considerable improvement, and a letter to his employer in a conditional reinstatement. He now, a year later, reports that he has retained his post.

Accuracy spells efficiency, comfort, first cost of glasses least cost; and, as bad spelling is now known to be often due to uncertain memory pictures the result of defective sight, accuracy spells spelling.—I am, etc.,

RALPH HOPTON, M.D. Lond.,

Consultant to the Leeds Education Authority;
Eye Surgeon to the Blind School.

Leeds, June 5th.

THE PREVENTION OF PUERPERAL INFECTION.

SIR.—For many years I have read with interest various articles on puerperal sepsis. All the authors advise the use of gloves, yet I have nowhere seen stated how long they should be boiled. Upon the details of the process employed rests the success or otherwise of this method. Unless the most scrupulous care be taken the chances of failure are considerable. For nearly ten years I have never made an examination without using a sterilized glove. The method I adopt is as follows:

On entering the house I ask for a saucepan with lid, a clean pocket-handkerchief, and boiling water, and that the gas stove be started. The glove or gloves (it is better to sterilize two or more at the same time) are each rolled up in a handkerchief beginning at the fingers, first having had at least an ounce of boiling water poured inside to wet all the fingers. They are placed in the pan and boiling water is poured over them, sufficient to boil for fifteen minutes without being dried up. A 4 oz. ear syringe is filled with hot water and also put in the pan. The lid is placed on, and I wait until I am sure all is at boiling point and boil for fifteen minutes. It is necessary to tell the people on no account to interfere with the boiling process.

In the meantime I commence cleansing my hands, continue this for five minutes, then go and see the patient, then resume cleansing the hands, telling the attendant with clean hands to give the patient a good wash with soap and water. It is no use in an ordinary case to suggest shaving the parts. Even the cutting off of extra long hair is resented.

At the end of fifteen minutes the lid is removed and the whole sufficiently cooled with ordinary tap water. The folded handkerchief and the syringe are removed to a basin of 1 in 1,000 biniodido. The vulva is separated by pulling on the neighbouring skin and washed by a stream of antiseptic by means of the syringe. The glove is now unrolled in the solution and the wrist picked up (allowing plenty of solution to float inside) and drawn on the hand to be used. It is assumed that the glove has been made right or left as the case may be, at the beginning. The examination is now made, using no lubricant. It is sometimes a little difficult, but a gentle rotary motion of the hand will overcome this. At the conclusion of the examination the glove is taken off and not used again.

I consider that two things are of the utmost importance. The glove must be sterilized on the spot, and it must be rejected after the examination, and a fresh one used if further interference is necessary. Of course, when forceps

are used, all are boiled together, but even then I roll up the glove.

Unless practitioners are prepared to take similar care in the use of gloves, it will be, in my opinion, much better to trust to the hands.—I am, etc.,

June 3rd.

OPOPONAX.

SIR,—In the articles and letters on puerperal infection two points of interest have received insufficient attention. In the first place, how far is puerperal septicaemia due to the fact that a small proportion of patients have not the ordinary immunity to the risks of infection. The absence of this immunity rather than the presence of any special form of infection may be responsible for a large proportion of the cases of septicaemia. We have all seen cases in ordinary practice in which a simple superficial infection by a common organism (such as the *Staphylococcus aureus*), in the form of a small boil, has proved fatal owing to the want of power to acquire immunity. I do not recollect any report of an investigation of the discharge from the anterior vagina taken day by day for the first week after a normal confinement, but in appearance and odour such discharge suggests organism infection in many patients who show no evidence of toxæmia.

Secondly, have we considered the point of view of the patient herself? In most women a confinement is one of the outstanding incidents of her life and largely a subject of conversation with her friends; the medical attendant who can give her a good hope of freedom from severe pain during that time, without unusual risk, is gratefully thought of. Delivery under anaesthesia is generally indefinitely delayed without instrumental help. To what extent is it proved that septicaemia is increased by such methods? It is of some value to the State for a patient to say that a confinement is "not so bad after all," and that she will not fear to run a similar risk again, as against instances where a woman says that her experience of her first confinement was sufficient to make her prevent a similar occurrence for many years. We cannot ignore altogether the patient's point of view, and an explanation of the risk of sepsis is poor consolation to a woman in a long second stage of a first labour.—I am, etc.,

June 6th.

H. S.

SIR,—When bits of placenta, membranes, blood clots, or other dead animal matter remain in the uterus for a little time after parturition they will usually become infected with dangerous bacteria, and puerperal fever will be likely to result. One of the first points therefore in preventing puerperal infection is to prevent, as far as possible, the retention of putrefiable material in the uterus. I have seen a case where death resulted from a tiny and hardly visible shred of dead tissue adherent to the interior of the uterus, a small abscess resulting opposite it on the exterior surface of the uterus. This abscess opened by a pin-hole opening into the peritoneal cavity, and death resulted. The presence of such shreds cannot readily be suspected or avoided without precautions not often adopted and not to be recommended as routine measures. If, however, a patient suddenly develops rigors and the temperature begins to rise, there is not a moment to be lost. The interior of the uterus should, in my opinion, at once be thoroughly swabbed or scrubbed out with a strong undiluted antiseptic by means of cotton-wool wrapped firmly on a strong uterine probe or sound. I have known this treatment stop at the commencement what seemed certain to be a virulent puerperal fever. In a few hours it will often be too late. The infective material must be removed or rendered harmless before the infection has spread beyond control.—I am, etc.,

June 3rd.

M. A. O.

THE ORGANIZATION OF SCHOOL OPHTHALMIC WORK.

SIR,—Mr. Bishop Harman states that "at present infants under the age of 7 years attending school do not have their eyes examined." Doubtless this is true of many educational areas, but I should like to point out that in the schools administered by the School Board of Glasgow the children in the infant departments have been regularly examined by the visiting oculist since 1905.

The examination is by retinoscopy and is rapidly done with the aid of a skiascope, which I described in the *Ophthalmic Review*, July, 1905. The children are brought into the dark room by classes, and are entirely under the control of their teachers, one of whom attracts the attention of each individual child while under examination. The co-operation of the teachers is essential, but in an experience extending over many years I rarely failed to obtain this, and I think the main reasons were that (a) the results of the examination were often of practical interest to them, and (b) they themselves realized that only with their help could the examination be carried out in a reasonable time.

Mr. Harman indicates the desirability of a routine examination of the eyes of infants, and the object of my letter is to show that such an examination is not only practicable but is an established custom here in Glasgow.

Further, I should like to add that the subjective testing of the older children is done entirely by the teachers.—I am, etc.,

Glasgow, May 28th.

H. WRIGHT THOMSON.

SIR,—Until the organization of school ophthalmic work is put on a better footing there is not likely to be more men seeking qualifications for doing this special work. For the majority it would be throwing time and money away. I know a man who has given four years to work in one of the London ophthalmic hospitals, and as clinical assistant in the eye department of one of the large general hospitals, ultimately becoming the senior clinical assistant. Nearly two years since he was appointed by a county council to do this special work, but during that time he has been favoured with one case only; there have been some 600 in all (it is not possible to find out the exact number); these have been examined and the fees taken by the assistant school inspector and his partner. I make no charge of unfairness or greed, I only mention the fact which speaks for itself, and I shall be pleased to communicate with Mr. Harman if he wishes to verify the statement. But whilst human nature remains what it is, I quite agree with him when he says, "there are advantages in separating the work of school medical inspector from the treatment of children found to be defective." At any rate, this kind of thing should be made impossible in a liberal profession, and until it is, it is no use asking medical men to give up time to acquire this special knowledge.—I am, etc.,

May 31st.

PAX.

COCYGEAL FISTULAE.

SIR,—Mr. Lockhart-Mummery, in your issue of June 4th, expresses the opinion that all fistulae met with in the neighbourhood of the tip of the coccyx, which do not communicate with the rectum, are congenital in origin. This is scarcely correct, because I have notes of a case of coccygeal fistula which was the result of necrosis of the coccyx. Also there is a type of fistula, having no communication with the rectum, which is the result of suppuration of the presacral lymphatic glands. The abscess thus formed, being bounded behind by the sacrum, and in front by the fascia propria of the rectum, has no alternative but to find an exit through the skin between the anus and the tip of the coccyx. Sometimes there is a single opening on one side of the middle line, but often there is a second opening on the opposite side, the result being a vertical horseshoe fistula. There is no doubt, however, that fistulae of congenital origin occur in this locality, but they are extremely rare. Although such a fistula may not make its appearance until comparatively late in life, in all cases it has been preceded either by a tumour or by a post-anal dimple.

Bland-Sutton, to whom, as Mr. Lockhart Mummery says, we owe our knowledge of the origin of this type of fistula, writes thus in his work on *Tumours* (fourth edition, page 432):

"Post-rectal dermoids sometimes open spontaneously in the perineum; the fistula is usually situated in the middle line of the perineum near the tip of the coccyx."

Again, on page 436, he says:

"Faulty coalescence of the cutaneous covering of the back often occurs over the sacral vertebrae, and gives rise to small congenital sinuses known as post-anal dimples and coccygeal sinuses."

The congenital coccygeal fistula should not be confounded with the condition known as sinus over the sacrum and coccyx, which, though rare, is infinitely more commonly met with. Apparently Mr. Lockhart-Mummery fails to discriminate between these two totally distinct conditions, because he says that several years ago the late Mr. Goodall (evidently a misprint for Goodsall) described a number of cases of fistulae over the coccyx, which were difficult to heal, but did not recognize their nature.

Goodsall and I, in our book *Diseases of the Anus and Rectum* (Part I, p. 187), devote a chapter to a lesion which we term "sinus over the sacrum and coccyx," and give notes of ten typical cases. In this disease there is always a clear history of antecedent traumatism, leading ultimately to an abscess, which usually is allowed to burst spontaneously. The resulting aperture is nearly always situated to the left of the middle line, at or about the level of the upper extremity of the internatal cleft and a long way from the tip of the coccyx. The site of the external opening is well shown in Fig. 69 of our book. That these sinuses are not congenital in origin appears from the following reasons:

1. Their appearance is never preceded either by a tumour or by a dimple.
2. The opening is never in the middle line.
3. The primary opening is never near the tip of the coccyx.
4. The sinus is never lined by skin.
5. The opening is usually surrounded by exuberant granulation tissue, similar to that met with in sinuses connected with carious bone.
6. The aperture often temporarily becomes closed—an impossibility if it were of congenital origin, owing to the epithelial lining.
7. Neither hair nor teeth are ever found in them.
8. The sinus can be effectually cured by simply laying it open freely, together with its lateral offshoots, and it is never necessary to excise any tissue whatever.

The mere fact that a sinus in the anal region is found to be lined by epithelium does not necessarily mean that it is of congenital origin. It is not an uncommon experience to find that the track of an anal fistula, if it has been in existence for a considerable time, and especially if it is short and wide in calibre, has become lined by epithelium from the external to the internal openings. This is not to be wondered at, because we know that many sinuses in connexion with long-standing bone disease become so lined, as does also the canal made through the lobule of the ear for the reception of an earring.—I am, etc.

London, W., June 7th.

W. ERNEST MILES.

INTERMISSIONS IN TRYPANOSOMIASIS.

SIR,—I see from the report of the meeting of the Royal Society of Tropical Medicine and Hygiene, on May 20th, in the *BRITISH MEDICAL JOURNAL* for May 28th, that both Dr. Manson-Bahr and Dr. Low were of opinion that cases of trypanosomiasis could not be regarded as cured until a period of at least three years had elapsed since the last appearance of the parasite in the blood.

In support of this view I may mention that, when in medical charge of the sleeping sickness area of Nyasaland in 1913, one of my patients, a child of 7, showed numerous trypanosomes (*T. rhodesiense*) in the blood on first examination, but none on many subsequent occasions until about a year later, when the trypanosomes reappeared, the symptoms, which had been in abeyance, returned, and death followed shortly afterwards. Owing to the opposition of the parents the child received no treatment of any kind, but was kept in his own village and away from the fly-infested bush.

The occurrence, in untreated cases, of such long intervals during which no trypanosomes are found in the peripheral circulation and the symptoms are stationary or absent, makes one hesitate before accepting Dr. Marshall's cases as permanent cures until a longer period has passed without relapse.—I am, etc.,

Duff House, Baff, May 31st.

PHILIP CONRAN.

ENUCLEATION OF THE TONSILS.

SIR, In the *JOURNAL* of June 11th, under the heading of the Laryngological Summer Meeting, I am reported to hold the view that enucleation of the tonsils for enlargement is unjustifiable.

The published title of the paper which I was to read was not my own wording, and, as I was subsequently

informed, it gave rise to a general misunderstanding as to my views. My contention is that enucleation as the routine method for dealing with all tonsils which are enlarged is unjustifiable, especially as all enlarged tonsils are not diseased. I am of opinion that enucleation should be reserved for diseased tonsils or conditions which necessitate the removal of the tonsils, such as chronic peritonsillar abscess, etc. The scarring which frequently results from enucleation may seriously impair and even cause loss of a singing voice in an adult, and may prevent the formation of a singing voice when the operation is performed in childhood. The operation, moreover, is not unattended with danger from severe haemorrhage. There have been many deaths from this cause (I referred to a throat specialist who, up to a year or more ago, had lost four patients from haemorrhage), and not only is the frequency of its occurrence shown by the numerous instruments which have been devised recently to deal with this condition, but to the subject being considered of sufficient importance to call for a discussion at the forthcoming meeting of the British Medical Association at Newcastle.

London, W., June 13th.

T. MARK HOVELL.

THE NOTIFICATION FEE AND THE END OF THE WAR.

SIR,—When I see a case of infectious disease I promptly notify it by telephone (cost 6d.), in order to ensure speedy removal. Postal facilities in this village are somewhat mediocre. Then, *pro forma*, I send on the usual certificate (cost 1d.). Subsequently I receive 1s. for my trouble; net profit 5d. I am informed that I am doing this because we are still at war with Turkey. How much longer are we to remain at war with Turkey? And what has Turkey to do with it, anyhow?—I am, etc.,

H. W. POOLER, M.B.,

Honorary Secretary, Chesterfield Division.

Alfreton, June 13th.

Obituary.

JOHN MATTHEW FORTESCUE-BRICKDALE,

M.A., M.D. OXON., M.R.C.P. LOND.,

Physician, Bristol Royal Infirmary.

The death of Dr. Fortescue-Brickdale at the early age of 51 has deprived the profession in Bristol of a physician who combined a scientific knowledge of medicine with a wide knowledge of literature and a love of the arts, especially music. He was the younger son of the late Matthew Inglett Fortescue-Brickdale, conveyancing counsel to the Court of Chancery. Educated at Dulwich College, Christ Church, Oxford, and Guy's Hospital, he settled in Bristol in 1903. Soon after his arrival he was appointed assistant physician to the Royal Hospital for Women and Children. He also held the appointment of lecturer in pharmacology in the University of Oxford. In 1908 he was elected assistant physician to the Bristol Royal Infirmary and physician in 1919. At the time of his death he was physician to Clifton College and director of the University Public Health Laboratory.

During the war Dr. Fortescue-Brickdale served for two years in France, and contracted there a severe illness, from which he seemed never to have recovered completely. Upon his return from France he was given charge of a special centre at the 2nd Southern General Hospital, Southmead, for cases of chest wounds, on which he published a report in the *Quarterly Journal of Medicine* in 1918. His other publications included a book written in collaboration with Professor Francis, *The Chemical Basis of Pharmacology, A Practical Guide to the Newer Remedies, A Textbook for Nurses* (with Mr. Hey Groves), and *A Textbook of Pharmacology and Medical Treatment for Nurses*. His literary accomplishments made him a valued member of the editorial staff of the *Bristol Medico-Chirurgical Journal*.

Apart from his exceptional intellectual endowments, Fortescue-Brickdale was possessed of a singular personal charm. Grave of aspect, he had nevertheless a deep fund of humour, and could talk entertainingly on any topic. An old Oxford friend writes of him, "He was never one to reply monosyllabically to any remark; he had something of the touchstone in his composition; full of wit himself, he was as often the cause of wit in others." He took part

in many local activities, and for some years before his death had been churchwarden at All Saints Church, Clifton; for he belonged in religious thought to the school of George Herbert and Nicholas Ferrar. By family connexions he had long associations with Bristol, and his death is deeply deplored, not only by his medical confrères and by the masters and boys of Clifton College, but by a wide circle of friends who knew his sterling worth. He leaves a widow and two sons.

We regret to record the death of Dr. HUGH DAVIES-JONES, which took place at Mountain Ash on June 6th, 1921, at the age of 66. He was a native of Menai Bridge, Anglesey, and was educated at Edinburgh and Glasgow, and took the diplomas of L.R.C.P. and S.Edin. in 1880. After acting as assistant to the late Dr. Benjamin Williams of Mountain Ash he went to Llangollen, North Wales, where he practised for about seventeen years. He returned to Mountain Ash in 1903 on the death of his brother, the late Dr. Daniel Davies-Jones, and became surgeon to Messrs. Nixon's Collieries and the Powell Duffryn Colliery. He was a very active member of the British Medical Association. He had been Chairman of the North Glamorgan and Brecknock Division, was a member of the Executive Committee, and represented the Division on the Branch Council; he had recently been appointed to represent the South Wales Branch on the Welsh National Memorial Association. He was very faithful in his attendance at the Division meetings and its committees, and only four days before his death was present at a Division meeting held at the General Hospital, Merthyr. He devoted a good deal of time to ambulance work; he was a lecturer and examiner in the St. John Ambulance Association, and had held very successful classes; recently he received a handsome presentation from one of his classes. Apart from his profession he took an active interest in the welfare of his town, and he and his family gave material and financial assistance to all good causes; during the war, though 60 years of age, he joined the V.T.C. and was a very active member; afterwards he received a commission. He was a kind and genial gentleman, very sympathetic to his patients, and greatly liked by them. He was skilled in his profession, but of a retiring disposition, and did not carry either his heart or his knowledge on the surface. He leaves a widow, two sons, and four daughters to mourn his loss. His two sons are members of the medical profession, the elder having been with his father, while the younger, recently qualified, is a resident at the King Edward VII Hospital, Cardiff. The local profession has lost a staunch friend who will be greatly missed in many spheres.

DR. JOHN GOODWIN SHEA, who died suddenly on March 21st, was born in Dublin in 1856. He took the diploma of L.R.C.S.I. in 1880, and that of L.R.C.P.I. in 1882, and settled in Chesterfield in 1885; after acting for some years as assistant to the late Dr. Jefferies, he succeeded him in practice. Dr. Shea became F.R.C.S.I. in 1894, and graduated M.D. Durham in 1902. He was a J.P. of the borough of Chesterfield for many years, and on the honorary staff of the Chesterfield Royal Hospital. In June of last year he retired from active practice to Ewell, in Surrey. He was a past president of the Midland Branch of the British Medical Association.

The Services.

OFFICERS' ALTERNATIVE PENSIONS.

THE Ministry of Pensions announce that officers and nurses disabled by service in the great war who intend to claim alternative retired pay or pension, based on pre-war earnings and present earning capacity, must make application before July 2nd, 1921, or before a year has elapsed since the first award of disability retired pay or pension, whichever is the later date. Applications for alternative pensions by widows of officers whose deaths were due to service in the great war must also be made before July 2nd, 1921, or within a year of the date of first award of the flat-rate pension. A widow who may not be eligible at present owing to the receipt of allowances for children, but who may become eligible when these allowances cease, must make application before July 2nd, 1921, in order to establish her future claim. The provision relating to the time

limit is contained in the Royal Warrant of July 2nd, 1920, and was necessitated by the difficulty experienced in obtaining proof of pre-war earnings. Under the terms of the Royal Warrant a disabled officer is not eligible for alternative retired pay if his pre-war earnings did not exceed £132 a year, nor is a disabled nurse eligible for alternative pension if her pre-war earnings did not exceed £95 a year. In the case of officers' widows there is no fixed limit.

As the substitution of alternative retired pay or pension for the ordinary flat-rate pension represents in some cases a substantial addition to the amount of the pension, disabled officers and nurses, and officers' widows who have not yet made application, should ascertain without loss of time whether they are entitled to the benefits of the alternative system. Applications and inquiries should be addressed to the Officers' Branch, Ministry of Pensions, Cromwell House Annexe, Millbank, S.W. 1.

HONOURS.

THE following awards are announced for services rendered during the operations in Waziristan:

C.S.I.—Colonel Charles W. Profeit, C.M.G., D.S.O., A.M.S.
C.I.E.—Colonel Thomas Stodart, I.M.S., Lieut.-Colonel (acting Colonel) Corrie Hudson, I.M.S.

O.B.E. (Military Division).—Captain (acting Lieut.-Colonel) Alexander G. Biggam, R.A.M.C., temporary Captain Nitya Nand Joshi, I.M.S., Major Thomas C. C. Leslie, R.A.M.C., Major (acting Lieut.-Colonel) Herbert B. Scott, I.M.S., Major (acting Lieut.-Colonel) Francis B. Shettle, I.M.S., Captain and Brevet Major (temporary Major) John A. Sutton, V.C., I.M.S., Major George S. Wallace, R.A.M.C., Major (temporary Lieut.-Colonel) Norman M. Wilson, I.M.S.

To be Brevet Lieutenant-Colonel. Major T. S. Dudding, O.B.E., R.A.M.C.

Bar to M.C.—Captain William J. S. Ingram, M.C., I.M.S.

M.C.—Temporary Captain Banwari Lal Gupta, I.M.S., temporary Lieutenant Mangalore Gopal Kini, I.M.S., temporary Captain Kishan Ganesh Mobile, I.M.S., Captain (acting Major) D. Reynolds, R.A.M.C., temporary Captain Sarevanamathar Thambiah, I.M.S.

The following are also mentioned for distinguished service: Major acting Lieut.-Colonel John Anderson, I.M.S., Major Duncan Coutts, I.M.S., Captain Radha Krishna Dewan, I.M.S., T.C., Major Charles H. Fielding, I.M.S., Captain (acting Major) Richard E. Flowerdew, I.M.S., Captain Cecil C. Harrison, R.A.M.C.(S.R.), Captain (acting Lieut.-Colonel) John Patrick Hubao, I.M.S., Captain Enathial John Koshi, I.M.S., T.C., Captain (temporary Major) Henry H. Mullholland, R.A.M.C., Captain (acting Lieut.-Colonel) Denis F. Murphy, I.M.S., Lieutenant Altamahomed Tajmahomed Shaikh, I.M.S., T.C., Captain (acting Lieut.-Colonel) Charles H. Smith, O.B.E., I.M.S., Captain Ralph R. Thompson, M.C., R.A.M.C., Captain (acting Major) Jagannath Balkrishna Vaidya, I.M.S., Mrs. Alice Penel, M.B., B.S., of the Afghan Mission Hospital, Bannu, together with twenty-three members of the Indian Medical Department.

Universities and Colleges.

UNIVERSITY OF OXFORD.

Litchfield Lecturer in Medicine. Ernest Mallam, D.M. Magdalen College, has been appointed Litchfield Lecturer in Medicine for two years as from October 5th, 1921.

Examiner in Animal Physiology.—Leonard Hill, M.B., F.R.S., has been reappointed Examiner in Animal Physiology in the Final Honour School of Natural Science.

Election of Members of the Board of the Faculty of Medicine.—The following have been re-elected members of the Board of the Faculty of Medicine: E. W. Ainley Walker, D.Sc., D.M., Fellow of University College, J. H. Thursfield, D.M., Trinity College and St. Bartholomew's Hospital, Claude G. Douglas, B.Sc., D.M., Fellow of St. John's College.

The following have been approved at the examination indicated:

D.P.H.—Part I: H. L. Conlthard, E. ff. Creed, S.-cl-D. A. E. Daab, A. Hunter, J. B. Kirk, N. B. Lushington, E. Newton, S. G. Overton, A. J. Partridge, E. G. Rawlinson, W. G. Southey, C. J. Todd, M. P. Wilson. Part II, and received the Diploma: H. L. Conlthard, T. J. Lloyd, G. W. Ronaldson, C. W. Sharpley.

William Brown, D.M., D.Sc. (Christchurch), Reader in Psychology in the University of London (King's College), has been elected Wilde Reader in Mental Philosophy.

UNIVERSITY OF CAMBRIDGE.

DR. HAMPTON HARTRIDGE, Fellow of King's College, has been reappointed Senior Demonstrator in Physiology.

At a congregation held on June 10th the following medical degrees were conferred:

M.D.—A. C. Roxburgh.
M.B., B.Ch.—J. C. Andrews, R. A. W. Procter, M. B. R. Swann, J. W. McK. Nicholl, F. R. Hobbs.
B.Ch.—A. J. Copland.

The Registry calls the attention of the tutors and praefectors of colleges and of the deans of medical schools to the report of the Special Board for Medicine of May 4th, 1921 (Report, page 9-5), recommending important alterations in the terms for the sending in of the names of candidates, and for the presenting of certificates for the Third Examination for Medical and Surgical Degree. All medical students should be instructed to substitute the words *thirty just* for *ten* or *thirty-one* for *ten*, and *thirty-one days* for *three weeks*, on pages 11, 17, 35, 36 of the Regulations and Schedules for Medical and Surgical Degrees. The additional fee for late entry is £2.

UNIVERSITY OF LONDON.

DR. E. G. GRAHAM LITTLE has been elected by the Graduates of Medicine and Surgery of the University of London to serve his fifth term of office as their representative on the Senate.

The following have been recognized as teachers of the University in the subjects and at the institutions indicated:

London (Royal Free Hospital) School of Medicine for Women: Mrs. Anne L. Gilliat (Anaesthetics).

St. Mary's Hospital Medical School: Mr. C. W. G. Bryan (Surgery). Mr. A. Fleming (Bacteriology).

Dr. Jobson Horne has been appointed Semon Lecturer. The lecture, entitled "The relationship of the larynx to pulmonary tuberculosis," will be delivered at the rooms of the Royal Society of Medicine on July 5th at 5 p.m.

The duration of the appointments of Professor A. D. Waller, F.R.S., and Dr. T. D. Lister, C.B.E., as director and treasurer respectively of the Physiological Laboratory has been extended to the end of 1921. Dr. John Fawcett has been appointed a governor of the Lister Institute of Preventive Medicine, and Dr. A. Thomas a governor of University College, Aberystwith.

The following have been appointed staff examiners in the subjects of examination for medical degrees 1921-22:

Anatomy: Professor G. Elliot Smith, F.R.S., and Dr. W. L. H. Duckworth. *Bacteriology:* Professor R. T. Hewlett. *Chemistry:* Dr. H. R. Le Sueur and Professor W. H. Lewis. *Forensic Medicine and Hygiene:* Drs. R. A. Lyster and W. G. Savage. *General Biology: A. Eastwood, B.Sc., and Miss P. C. Esdaile. Medicine:* Drs. J. Calvert, C.B.E., J. Fawcett, R. T. Williams, and C. R. Box. *Mental Diseases and Psychology:* Drs. R. H. Cole and W. H. B. Stoddart. *Obstetric Medicine:* Dr. Comyns Berkeley, Professor T. Wilson, Dr. J. S. Fairbairn, and Dr. T. G. Stevens. *Oto-Rhino-Laryngology:* Sir W. Milligan and Dr. Herbert Tilley. *Pathology:* Dr. C. Bolton, C.B.E., F.R.S., and Professor H. R. Dean. *Pharmacology:* Professor F. Ransom and Professor G. A. Gunn. *Physics:* A. Wood, M.A., and Professor S. Russ. *Physiology:* Professor J. S. Macdonald, F.R.S., and Professor M. S. Pembrey. *State Medicine:* Drs. W. G. Savage and A. G. R. Foulerton, O.B.E. *Surgery:* J. Sherren, C.B.E., C. H. Fagge, E. W. Hey Groves, and Professor G. E. Gask, C.M.G., D.S.O. *Tropical Medicine:* Dr. G. C. Low.

Mr. H. J. Waring, C.B.E., has been elected chairman of the Brown Animal Sanatory Institution Committee for the remainder of the year 1920-21. The annual report of the superintendent of the institution stated that during the year 6,040 animals, including 2,823 dogs, 2,660 cats, and 221 horses were treated there. The five lectures required to be given under the will of the late Mr. Brown were delivered by the superintendent during December at the Royal College of Surgeons, the subject chosen being influenza. The superintendent had continued in the laboratories his work on influenza for the Medical Research Council, and some interesting results are to be published shortly. He had also carried on researches on leprosy, and on the ultra-microscopic virus group in addition to examining a number of pathological specimens from the hospital. Mr. Twort's appointment as superintendent of the institution has been continued for one year as from June 1st, 1921.

Applications for the post of professor of medicine and director of the medical clinic at St. Mary's Hospital School, salary £2,000 a year, must be received by the Academic Registrar, University of London, not later than the first post on June 23rd.

The following candidates have been approved at the examination indicated:

DIPLOMA IN PSYCHOLOGICAL MEDICINE (with special knowledge of Psychiatry).—C. Farrar-Ridge, W. Moodie, A. A. W. Petrie.

UNIVERSITY OF MANCHESTER.

THE following appointments have been made: *Demonstrators in Pathology:* P. I. C. Gibson, M.B., B.S., and A. Haworth, M.Sc., M.R., Ch.B. *Demonstrators in Anatomy:* Georgina May Duthie, M.B., Ch.B., and R. C. Shaw, M.R.C.S.

ROYAL COLLEGE OF SURGEONS OF ENGLAND.

New Fellows.

At a meeting of the Council of the Royal College of Surgeons, held on June 9th, with Sir Anthony Bowlby, K.C.B., President, in the chair, diplomas of Fellow were conferred upon the following twenty-five candidates (including one woman) who have passed the requisite examinations and have complied with the by-laws—namely:

K. B. Bellwood, E. C. Fowden, G. N. Brandon, G. W. Carte, H. Corsi, R. Coyte, S. G. Dunn, J. A. W. Elden, Satapriya Ghosh, J. B. Payeraft, S. N. Hayes, O. S. Hillman, J. B. Hunter, C. M. Jones, O. R. M. Kelly, T. P. Kilber, C. Lamrinudi, H. M. Livingston, R. P. S. Mason, R. L. Newell, H. C. W. Nuttall, K. G. Pandalai, R. H. O. B. Robinson, F. W. Watkyn-Thomas, H. W. Wookey.

Mr. James Sherren and Mr. L. Bathie Rawling were elected members of the Board of Examiners in the vacancies occasioned by the retirement of two previous members of the Board.

The following were elected as examiners in anatomy and physiology for the Fellowship for the ensuing year:

Anatomy: A. R. Thompson, J. E. S. Frazer, G. Gordon-Taylor, W. F. Haslam. *Physiology:* H. Willoughby Lyle, F. A. Bainbridge, A. Rendle Short, J. Mellanby.

The following recommendations for examiners in other subjects were adopted by the Council:

Elementary Biology: T. W. Shore, J. P. Hill. *Anatomy:* F. G. Parsons, David Hepburn, Arthur Thomson. *Physiology:* G. A. Buckmaster, H. E. Roaf. *Midwifery:* G. F. Darwall Smith,

Cuthbert Lockyer, G. Drummond Robinson, C. Inbert Roberts, *Diploma in Public Health:* Sir F. W. Andrews, F. N. K. Menzies, *Diploma in Tropical Medicine and Hygiene:* H. B. G. Newham (*Bacteriology*); G. C. Low (*Diseases and Hygiene of Tropics*). *Diploma in Ophthalmic Medicine and Surgery:* J. H. Parsons, H. W. Lyle, E. Treacher Collins. *Diploma in Psychological Medicine:* Sir Frederick Mott.

The following professors and lecturers were appointed for the ensuing collegiate year:

Hunterian Professors.—Sir Arthur Keith: Six lectures on "The comparative osteology of human races," illustrated by collections in the Museum. Harold Burrows, C.B.E.: Two lectures on "The results and treatment of gunshot wounds of the blood vessels." Alfred G. T. Fisher: One lecture on "The pathology of chronic arthritis, with remarks on the basal principles of treatment of joint disease as indicated by anatomical and physiological observations." Charles A. Pannett: One lecture on "Hydronephrosis." Alan H. Todd: One lecture on "Orthopaedic aspects of rheumatoid arthritis." Kenneth M. Walker: One lecture on "Enlargement of the prostate."

Arris and Gale Lecturers.—V. Zachary Cope: One lecture on "The nerve supply of the parietal peritoneum and superperitoneal tissues." F. W. Edrige-Green, C.B.E.: One lecture on "New researches in colour vision." Swale Vincent: One lecture on "A critical examination of current views on internal secretion."

Erasmus Wilson Lecturer.—S. G. Shattock: Six demonstrations or pathological specimens in the Museum.

Arnott Demonstrator.—Sir Arthur Keith: Six demonstrations or the contents of the Museum.

Thomas Vicary Lecturer.—Sir Charles A. Pallance: Historical lecture.

A vote of congratulation was accorded to Sir Arthur Keith on the honour of knighthood conferred on him.

It was resolved that the examinations for the primary Fellowship should be held in June and December in 1922 and until further notice.

ROYAL FACULTY OF PHYSICIANS AND SURGEONS,
GLASGOW.

At the monthly meeting of the Royal Faculty of Physicians and Surgeons of Glasgow held on June 6th, the following were admitted (after examination) as Fellows: J. H. Fyfe, A. M. Laurie, T. T. Read, J. D. Wright.

ROYAL COLLEGE OF PHYSICIANS OF IRELAND.

At the monthly business meeting of the President and Fellows held on June 3rd the Most Rev. and Right Hon. John H. Bernard, D.D., Provost of Trinity College, Dublin, was unanimously elected an Honorary Fellow of the College.

The following candidates, having passed the Membership Examination, were duly admitted Members of the College: L. Abrahamson, J. W. Bigger, C. Dickson, J. D. Sandes.

Medical News.

DR. MILES HARRIS PHILLIPS, surgeon to the Jessop Hospital for Women, Sheffield, has been appointed Professor of Obstetrics and Gynaecology in the University of Sheffield.

DR. E. F. HOARE, of the Middle Temple, and Dr. E. G. ANNIS, of Lincoln's Inn, have been called to the Bar.

A VACATION course of post-graduate instruction has been arranged at the Post-Graduate College, West London Hospital, Hammersmith, W., commencing on August 2nd and ending on August 27th. Further particulars can be obtained on application to the Secretary of the College.

DR. W. M. PALMER, of Linton, author of a number of works on the antiquities of Cambridgeshire, has been elected a Fellow of the Society of Antiquaries of London.

THE Council of the Royal Society of Medicine has awarded a Gibson Research Scholarship to Miss Gertrude M. A. Herzfeld, M.B., Ch.B., F.R.C.S. (Edin.), of Edinburgh. The scholarship will be held for two years, with a possibility of renewal for a third year.

WE are asked to state that Dr. Rollier has arranged to give a short post-graduate course of demonstrations on heliotherapy, at Leysin, from August 16th to August 20th.

THE new offices of the General Nursing Council for England and Wales at 12, York Gate, at the corner of Marylebone Road, were opened by Princess Christian on June 10th. The Council was called into existence by the Nurses' Registration Act, 1919, primarily to form and keep a register of nurses for the sick, in accordance with the provisions of the Act. It consists of two persons appointed by the Privy Council, two by the Board of Education, and five by the Ministry of Health, together with sixteen nurses selected by, among others, the Central Committee for the State Registration of Nurses, the College of Nursing, and the Royal British Nurses Association. Of the five members nominated by the Ministry of Health, two—Sir T. Jenner Verrall, LL.D., and Dr. E. W. Goodall, O.B.E.—were appointed at the suggestion of the British Medical Association.

THE fiftieth inter-hospital athletic sports will be held at Queen's Club, Barons Court, S.W., on Tuesday, June 28th, commencing at 2.30 p.m. The prizes will be presented by Viscountess Goschen. Further particulars can be obtained from Mr. L. G. Housden, Honorary Secretary U.H.A.C., Guy's Hospital, S.E.

DR. JAMES GRANT, who has practised at Rhynie, Aberdeenshire, for thirty-three years, has been presented by his patients and friends with an illuminated address and a cheque for £300, in appreciation of his valuable services to the community.

THE Ministry of Health has, at the request of the Metropolitan Water Board, issued a circular to metropolitan borough councils and sanitary authorities within the area of the Board inviting them to restrict the use of water for the watering of streets and the flushing of sewers. The shortage of the metropolitan supply of water is attributed to the prolonged drought.

A COURSE of twelve practical demonstrations on the management and feeding of infants and young children is being given on Tuesdays and Thursdays at the St. Marylebone General Dispensary, 77, Welbeck Street, W., by Dr. Eric Pritchard. Arrangements have been made to visit the Nursing Training School, 1, Wellgarth Road, Golders Green, N.W., to see the methods employed there in dealing with infants. The fee for the course, which commenced on June 14th, is £22s.

THE annual post-graduate class in oto-rhino-laryngology will be held in Professor Moure's clinic at Bordeaux from July 18th to July 30th.

THE Department of Medical Zoology in the School of Hygiene and Public Health, Johns Hopkins University, has arranged to send an expedition to Porto Rico this summer to study malaria and other problems arising out of disease-producing protozoa.

THE second International Congress for the Protection of Childhood will take place at Brussels from July 18th to 21st. The subscription for members is 25 francs, for associate members 10 francs. The organizing secretary is M. H. Velge, 27, rue de Turin, Brussels.

AT the last meeting of the Central Midwives Board for England and Wales, Sir Francis Champneys in the chair, it was reported that copies of the Central Midwives Board (Terms of Office) Order, 1921, had been forwarded from the Ministry of Health, the Order giving effect to the representation made by the Board on January 20th, 1921, that each of the members who, according to the Central Midwives Board (Constitution) Order, 1920, were to be appointed for a term of three years, should be appointed instead annually. It was announced that the Home Office had informed the Midwives Institute that, by virtue of the Regulations to be issued under the Dangerous Drugs Act, 1920, certified midwives who had notified their intention to practise would be authorized, under appropriate conditions, to purchase and be in possession of medicinal opium for use in the practice of midwifery.

THE German Congress of Internal Medicine will be held at Wiesbaden in 1922 under the presidency of Professor Wenckebach. The subsequent congress will be held in Vienna.

AN international congress of ophthalmology will be held at Washington from April 18th to 22nd, 1922, under the auspices of the American Ophthalmological Society, the Ophthalmological Section of the American Medical Association, and the Academy of Ophthalmology and Oto-rhino-laryngology.

THE twenty-sixth Dutch Congress of Public Health will be held in September at Arnhem, when the following subjects will be discussed: (1) Notification of infectious diseases; reporters, Kuiper (Amsterdam) and Kapsenberg (Groningen). (2) Destruction of vermin; reporters, Ringeling and Wolf (Amsterdam).

THE first stone of a Rockefeller tuberculosis dispensary has been laid at Bordeaux to commemorate the 284 American nurses who died during the war.

THE Municipal Council of Paris has decided to increase the fee payable to medical men summoned by the police to 20 francs.

AT a recent meeting of German scientists measures were agreed on as to the preservation of the most important features of scientific research under present social conditions. It was decided that subsidies should be secured for the 400 most important of the (roughly) 3,000 scientific journals published in German. To meet the lack of foreign publications a single large levy was voted to provide German readers with the most important foreign journals. Expedients were also found to combat the

shortage of research apparatus, drugs, experimental animals, and the like by centralizing the machinery for their purchase and distribution.

THE late Mr. Rutherford J. Pye-Smith, F.R.C.S., Emeritus Professor of Surgery in the University of Sheffield, has left estate of the gross value of £7,595, of which £3,603 is net personalty. He left the residue of his estate to his wife for life, and subject to her interest bequeathed £1,000 to the University of Sheffield for the chair in surgery, £100 to the Sheffield Royal Hospital, and £50 each to the Broompark Mission, Sheffield, the Edinburgh Medical Mission, and the Pye-Smith Scholarship Fund, Walthamstow Hall, Sevenoaks.

AT a meeting of the Society of Public Analysts on June 1st a paper on the composition of so-called egg powders was read by Beach, Needs, and Russell, comparing them with ordinary baking powders. A table of compositions was given, and it was suggested that a standard might be laid down for a minimum percentage of actual egg in such preparations.

DR. FRANCIS J. STUBBS has retired from the post of Medical Officer of Health to the Borough of Camberwell, after thirty years' service.

THE International Labour Bureau at Geneva has published figures showing that eleven nations (not including Russia, Turkey, Bulgaria, and Australia) have had 5,500,000 men disabled in the war. Of this number France has 1,500,000; Germany, 1,400,000; Great Britain, 1,170,000; Italy, 570,000; the United States, 200,000; Czechoslovakia, 175,000; Canada, 88,000; Rumania, 84,000; and Belgium, 40,000. Reports sent by the different Governments show that only a few of the disabled men now remain in military hospitals, and that the majority of the severely wounded who have been properly trained and provided with suitable appliances are capable of earning their livelihood, but there is difficulty in finding occupation for them all.

THE American Hospital Association will hold its annual conference at West Baden, Indiana, from September 12th to 17th.

A HOSPITAL ship to contain 500 patients is being built at Philadelphia.

Letters, Notes, and Answers.

As, owing to printing difficulties, the JOURNAL must be sent to press earlier than hitherto, it is essential that communications intended for the current issue should be received by the first post on Tuesday, and lengthy documents on Monday.

ORIGINAL ARTICLES and LETTERS forwarded for publication are understood to be offered to the BRITISH MEDICAL JOURNAL alone unless the contrary be stated.

CORRESPONDENTS who wish notice to be taken of their communications should authenticate them with their names—of course not necessarily for publication.

AUTHORS desiring reprints of their articles published in the BRITISH MEDICAL JOURNAL are requested to communicate with the Office, 429, Strand, W.C.2, on receipt of proof.

IN order to avoid delay, it is particularly requested that ALL letters on the editorial business of the JOURNAL be addressed to the Editor at the Office of the JOURNAL.

THE postal address of the BRITISH MEDICAL ASSOCIATION and BRITISH MEDICAL JOURNAL is 429, Strand, London, W.C.2. The telegraphic addresses are:

1. EDITOR of the BRITISH MEDICAL JOURNAL, *Aitiology*, Westrand, London; telephone, 2630, Gerard.

2. FINANCIAL SECRETARY AND BUSINESS MANAGER (Advertisements, etc.), *Articulate*, Westrand, London; telephone, 2630, Gerard.

3. MEDICAL SECRETARY, *Medisera*, Westrand, London; telephone, 763, Gerard. The address of the Irish Office of the British Medical Association is 16, South Frederick Street, Dublin (Telegrams, London); Dublin; telephone, 4737, Dublin; and of the Scottish Office, 6, Rutland Square, Edinburgh (Telegrams, *Associate Edinburgh*; telephone, 4301, Central).

QUERIES AND ANSWERS.

DR. J. MOSELEY: I find in a mixed or mixed staphylococci abscesses has been seen in infantile eczema, which, when continuing at the time of eruption, may last for months.

T. M.: A few general medical officers of health to an urban district council from the clerk to the council the Sanitary Officers (London) Order, dated December 13th, 1919, Article 10 of which defines the duties of a medical officer of health. Textbooks he will find useful are *Higgins and Public Health*, by Whitelegge and Newman, published by Cassell and Co.; *Hygiene*, by Notter and Firth, published by Longmans and Co.; and *Sanitary Law and Practice*, by Robertson and Porter, published by the Sanitary Publishing Company, Ltd.

"OXYURIS VERMICULARIS."

DR. K. R. COLLIS HALLOWES (Peebles) writes in reply to "Worried": (a) Take care to prevent reinfection by prohibiting articles of diet that may be infected. (b) Internal administration of sulphur in increasing doses. (c) Wash round anus at bedtime, thoroughly dry, and apply a weak mercurial ointment.

"H. D. J." writes: If "Worried" tries aloes wine, about half an ounce, taken early in the morning on an empty stomach once or twice a week, he will find that *Oxyuris vermicularis* is destroyed; also the purgative mineral waters, as "Rubinat" or "Apenta," taken three times a week, will be beneficial. For many years I suffered from the same complaint and cured myself with the above treatment. Reinfection plays an important part and great personal cleanliness is necessary, specially washing the hands and fingers after going to the w.c. The use of lettuce, as in salads, and watercress should be avoided; my experience is that they are a fruitful source of entozoa.

INCOME TAX.

"A. M." and a friend have bought a practice for £2,000, which is to be discharged by the handing over of the first two years' receipts from panel practice.

* "A. M." and his colleague are in partnership and are therefore assessable in one sum—less, of course, the personal allowances applicable to each. The panel receipts will have to be regarded as (gross) income of the firm; the fact that they are paid away in discharge of the capital liability to the outgoing practitioner does not affect their taxability.

"M. G." inquires whether he can claim the average of three years in connexion with the assessment of his fixed salary as full-time public health officer. In the first two of the three years he was in the army.

* Legally the salary is assessable on the basis of the current year and cannot be averaged with previous earnings. We believe that concessions were made in some cases where the three years' average did apply—for example, that a locum-tenent might average his military earnings, though they were dissimilar in nature; but we have not heard of any concession that would cover our correspondent's case.

"A. K." asks for further information with regard to the allowances for interest paid to a bank.

* The primary claim is that repayment is due on that portion of the taxed income which goes in payment of the overdraft interest; there is sometimes a secondary claim—namely, that the income as reduced by the payment is sufficiently low to permit of some allowances being claimed from which the claimant would otherwise have been barred. For instance, if the total income for 1919-20 were £1,050, of which £100 was paid away as bank interest, then the claimant would be entitled (a) to repayment on £100 and (b) to an adjustment in view of the fact that his net income was below £1,000, and he was therefore entitled to pay on that amount at a lower rate than before. We understand from the correspondence that for 1919-20 "A. K." had repayment under both heads, but that for 1920-21 the secondary claim does not arise, seeing that the rate of tax payable on his net income is not affected by the reduction caused by payment of the bank interest.

LETTERS, NOTES, ETC.

NEED FOR POST-GRADUATE INSTRUCTION IN MOUTH SEPSIS.

DR. M. ASTON KEY (Southsea) writes: I confess to a considerable degree of sympathy with your dental correspondent, "A. B. C." (June 4th, p. 842), in his endeavour to secure adequate opportunities for dealing with the treatment of oral sepsis in a post-graduate course.

In the practice of general medicine every week brings us some fresh evidence of the varied results, early or late, arising from this trouble. We who are in the first attacking line know the value of close co-operation with the dental surgeon, not merely to the extent of sending our patients to him, but in discussing with him both the clinical symptoms which we attribute to the sepsis, and also the mode by which he intends to attack it from his standpoint.

The interpretation of skiagrams, the use of high-pressure sprays, of vaccines, and of the many other lesser methods of treatment are all subjects which well repay conferences between physician and dental surgeon; as much and more may be said of wholesale extractions and the period of time over which they are distributed. It is right that we should know the treatments other than extraction which are at the disposal of our dental brethren; if for no other reason, it is useful in dealing with cases in which extraction is difficult or undesirable. As Dr. Pye-Smith used to say, "Commonest things occur most often," and we see the evil results of oral sepsis many times daily. One cannot but feel that such a subject deserves thorough handling in any post-graduate course.

"M.R.C.S." writes to express the opinion that after the paper by Sir W. H. Willcox on infective arthritis (June 4th, p. 804), in which the writer laid stress on the fact that the commonest cause of infection was to be found in connexion with the teeth sockets, and Dr. William Hunter's paper on "The coming of age of oral sepsis" (June 11th, p. 859), there ought to be little need for "A. B. C." to ask whether any post-graduate course can be considered to be complete without some practical instruction in this disease, with its far-reaching effects. "M.R.C.S." is very glad to see there is a prospect of the dean of the medical school to which "A. B. C." is attached arranging for a demonstration.

TOXINS AND NERVE CENTRES.

MR. H. V. DREW, F.R.C.S. (London, W.), writes: In 1913 I was privileged to observe the experimental work then being conducted by Dr. Teale at University College Hospital laboratories, by which he demonstrated that antitetanus toxin would prevent tetanus in animals if given before tetanus inoculation, but had no effect afterwards, and saw this illustrated during the war, when the subjects of tetanus were being, so to speak, "flooded" with tetanus antitoxin, those cases only recovering, as was observed by Hippocrates, which were not acute or chronic. Dr. Teale also demonstrated the reason—namely, that the antitoxin only reached the spinal cord through the nerves themselves and not through the general circulation, the same as in tetanus poisoning. This he clearly showed by coloured injections, which were easily traceable. My object in referring to the above experiments is again to emphasize the necessity of recognizing the bed-rock principle that all diseases are controlled by the vital centres in the medulla, until these are put out of action by the toxin of the special disease of which the patient is suffering—by the direct influence it exerts on those centres by its toxin attacking through the intraspinal fluid, in which they are bathed, and through which only can they be reached. In 1916 I was greatly impressed by the marked resemblance in certain cases between acute pneumonia and cerebro-spinal meningitis and the immediate relief to both afforded by tapping the theca, and the possible differential diagnosis effected by the examination of the cerebro-spinal fluid. Ever since, on reflection, I am more and more convinced that as the vital centres in the medulla control all the vital processes in health, so they are the first affected in disease, and that it is only by attacking the poisonous toxin through the spinal fluid, and by prevention of direct injury to these vital centres, by tapping, pending the results of some form of antitoxin treatment, through the spinal fluid, that success can be attained.

Since you last published a letter from me on this subject, I am glad to see that on these lines sleeping sickness has been successfully attacked, and I only wonder how many thousands of lives have been unnecessarily sacrificed in other diseases since you first published my contribution on this subject in 1917—and several notes since.

"THE BUFF BOOK."

WE have received communications from Dr. W. B. Norcott (Wallington, Surrey) and Dr. Charles Wheen (London, W.), stating that their names have been inserted in the "Buff Book" without their knowledge or consent.

A CATCH.

A CORRESPONDENT invites our opinion upon the following extract from a description of the test match in the *Times*:

"It was a powerful stroke, and Mr. Hendry, after stopping the ball high above his head, finally got control of it as he lay prone on his back."

The anatomist to whom we have referred the matter suggests that the last four words are a misprint for "supine on his face."

VACANCIES.

NOTIFICATIONS of offices vacant in universities, medical colleges, and of vacant resident and other appointments at hospitals, will be found at pages 31, 32, 33, 36, 37, and 33 of our advertisement columns, and advertisements as to partnerships, assistantships, and locum tenencies at pages 34, 35, and 36.

SCALE OF CHARGES FOR ADVERTISEMENTS IN THE BRITISH MEDICAL JOURNAL.

	£	s.	d.
Six lines and under	0	9	0
Each additional line... ..	0	1	6
Whole single column (three columns to page)	7	10	0
Half single column	3	15	0
Half page	10	0	0
Whole page	20	0	0

An average line contains six words.

All remittances by Post Office Orders must be made payable to the British Medical Association at the General Post Office, London. No responsibility will be accepted for any such remittance not so safeguarded.

Advertisements should be delivered, addressed to the Manager, 429, Strand, London, not later than the first post on Tuesday morning preceding publication, and, if not paid for at the time, should be accompanied by a reference.

NOTE.—It is against the rules of the Post Office to receive *postae restantae* letters addressed either in initials or numbers.

INTRINSIC CANCER OF THE LARYNX:

USUAL SITE OF ORIGIN, AS DEMONSTRATED AT 50 LARYNGO-FISSURES, AND ITS INFLUENCE ON DIAGNOSIS, PROGNOSIS, AND TREATMENT.*

BY

SIR STCLAIR THOMSON,

PROFESSOR OF LARYNGOLOGY AND SURGEON FOR DISEASES OF THE THROAT, KING'S COLLEGE HOSPITAL, LONDON.

It has been well said by McBride that in investigations on cancer of the larynx, the "pearl of great price is early diagnosis, for upon this depends the curability of the fell disease."¹ I think it is evident that many of the failures which overtook early efforts at cure by laryngo-fissure were due to delayed diagnosis. Just as early diagnosis and improved technique have advanced, so has this operation progressed until it has succeeded in securing more lasting cures than can be claimed for cancer in any other internal region of the body. Earlier diagnosis has also led to a steady diminution of the number of cases for which complete laryngectomy is the only possibility.

Last year I gave the results of an investigation into impaired mobility of a cord as an indication in diagnosis and prognosis in intrinsic cancer of the larynx, showing that it was neither a necessary nor a frequent symptom, that it was only met with in a minority of cases, and that, though it was a valuable symptom when present, other signs must be relied on for an early diagnosis.²

This summer I submit a research on another point which has not been settled and has threatened to mislead us. I refer to the current view that malignant disease of the endolarynx is most commonly met with in the posterior third of the glottis.

Historical.

Fortunately, in our speciality, and in this country, we need not go very far back to discover a source of error. If we turn to Morell Mackenzie's *Textbook*, published in 1880, we can detect one source and, at the same time, appreciate the progress made in the study of laryngeal cancer in forty years. On page 338 he begins his description by saying that "pain, dyspnoea and dysphagia are generally present," symptoms which, nowadays, we can only regard as indicative of a late and generally inoperable stage of the disease. It is true that he says, later on, that hoarseness may be a very early symptom, and sometimes precedes all other symptoms by months or even years; but the much greater prominence he gives to haemorrhage, fetor and cachexia would only mislead a present-day student. It is evident that he knew little of intrinsic cancer as we see and know it, possibly because forty years ago patients did not present themselves early for a persistent hoarseness, and even at the present day we know that medical men may fail to recognize the danger of delay in getting an expert opinion on a case of "mere huskiness." Mackenzie also misled a generation by stating (p. 336) that "the site of the tumour is in most cases one of the ventricular bands"; he even gives a table of 53 cases in which the cords only appear as the site of origin in 7 cases, and he points out that in 28 cases (or 56.7 per cent.) one of the ventricular bands was the first part affected.

By 1899 progress in diagnosis had been made, as shown by Lennox Browne's greater appreciation of the difference between extrinsic and intrinsic cancer, and his recognition of the fact that in the latter type "hoarseness is the earliest symptom of the disease and may have existed a very long time before advice will have been sought."³ But he also is mistaken when he writes that "enlarged experience convinces me that this form of cancer frequently commences in the ventricle." This teaching, in these two leading textbooks, was retarding progress.

Recent Views.

There can be little doubt that, as claimed by McBride,⁴ it was Semon who altered this view by showing from his experience that the intrinsic form of laryngeal cancer was more common than the extrinsic, and that the cords were "by far the most frequently affected parts." Semon recorded this as early as 1896⁵; it has been

confirmed by Schmiegelow, Chevalier Jackson and myself, and, doubtless, it is now admitted by all laryngologists. It was a great step forward. But, coming next to the consideration of which part of the cord is most frequently the site of origin, we see that Semon's independent observation was dimmed by the teaching of Virchow. He writes as follows: "Virchow has taught us that benign growths, if occurring on the vocal cords, have a tendency to localize themselves on their front parts, and very frequently on the anterior commissure of the vocal cords. If, on the other hand, you find a papillomatous-looking growth on the posterior parts of a vocal cord, particularly if the patient be well advanced in years, that is primarily suspicious, and still more so if such a growth be seated in the interarytenoid fold where benign growths practically never occur."

McBride, in summarizing Semon's teaching on this subject, gives as the first point of most importance, a "tumour which may be very minute, and, while it may be found in any part of the cord, is most commonly situated on the posterior third." I must confess that, like others, I accepted this teaching, and also McBride's statement, that Semon's observations "still remain the last important word which has been said on the diagnosis of early laryngeal cancer."⁶

Material and Methods.

The results of my own observations, which are now considerably larger than Semon's, will, I feel sure, demonstrate to your satisfaction that intrinsic cancer does not show a preference for the posterior part of the vocal cord, and that the interarytenoid region must be rarely affected—for I have never seen a case.

My conclusions are founded on 50 cases, in which the diagnosis was based not only on the appearances reflected in the laryngeal mirror, but also on the direct inspection of the disease when the larynx was opened by a laryngo-fissure. In addition, confirmation was sought in every instance by microscopic examination of the growth; the pathologist confirmed the clinical diagnosis in every case. I have never opened the larynx for epithelioma and found it to be anything else than cancer, although I have twice thought, at first, from clinical inspection that the disease was tuberculosis, but later on altered my diagnosis in time to secure a successful laryngo-fissure.

It will indicate the greater precision we are now able to arrive at in diagnosis if I recall that Grimwald, in 1907, recorded that out of 93 radical operations undertaken for the cure of what was supposed to be laryngeal cancer, the diagnosis turned out to have been mistaken in no less than 17—that is, in nearly 20 per cent. Jobson Horne, about the same date, formed the opinion that tuberculous disease was not infrequently mistaken for epithelioma, as he had learned from the examination of tissues sent him after removal by the mouth, by laryngo-fissure, or even with the entire larynx.⁷

Statistics.

These 50 cases have been tabulated according to the invasion by the neoplasm of (a) the anterior third of the cord only, (b) the middle third only, (c) the posterior third only; or combined invasion of (d) the anterior and middle thirds, (e) the middle and posterior thirds; or (f) the whole cord. I have also the numbers of the cases where (g) the anterior commissure or (h) the posterior commissure was attacked, and, finally, the statistics as regards (i) the subglottic area.

The results, so far as figures can express them, are as follows:

TABLE A.—Intrinsic Cancer.

Site of invasion in 50 cases.		
(a) Anterior third only of cord	...	3 cases
(b) Middle third only of cord	...	7 "
(c) Posterior third only of cord	...	0 "
(d) Anterior and middle thirds of cord	...	16 "
(e) Middle and posterior thirds of cord	...	3 "
(f) Whole cord	...	21 "
		50

TABLE B.—Intrinsic Cancer.

Extension in 50 cases to—		
(g) Anterior commissure	...	6 cases
(h) Posterior commissure (that is, the interarytenoid region)	...	0 "
(i) Subglottic region	...	13 "

* A paper read before the Summer Congress of the Section of Laryngology, Royal Society of Medicine, London, June 2nd, 1921.

Putting it, as regards the cords, in another way, I find that the portion of cord invaded by the cancerous growth is as follows:

TABLE C.—*Intrinsic Cancer.*
Third of cord invaded in 50 cases.

Anterior third in	39 cases
Middle third in	47 "
Posterior third in	24 "

In no single case was the growth at operation found to grow from any other area surrounding the glottis except the vocal cords and subglottic region.

Subglottic Cancer.

To have found the growth in the subglottic area in 13 out of 50 cases may come as a surprise. I was not prepared to find it, or, at least, to have found it so extensive, in several cases. Neither direct nor indirect laryngoscopy will always reveal it, but we may be prepared to meet it when the mobility of the cord is interfered with, and particularly when that mobility is impaired out of proportion to the visible extent of the lesion. Another discovery has been that a subglottic growth is more common in the anterior than in the posterior segment of the larynx. The subglottic invasion was found in one case where the anterior third only of the cord was affected; in 6 cases where only the anterior and middle thirds were attacked; and in 6 cases where the whole cord was invaded. But even in these last 6 cases, I hasten to say, the subglottic part of the growth was much more marked anteriorly, and, in some, was limited to the anterior half of the subglottic area. Indeed, as will be presently shown by illustrations, the cancer, in certain cases, undoubtedly originated below the anterior half of the cord, which it only invaded slowly and after it had made, relatively speaking, considerable progress before causing any symptoms. Want of tension in one cord was, in some cases, the first and only sign. Immobility of the cord is much more common in the subglottic cases; thus, in the 13 cases, the cord was fixed in no less than 6—that is, in nearly half the cases. Whereas, in the remaining 37 cases impaired mobility was only noted in 11—that is, in about 30 per cent. of them.

Author's View.

We now see that these 50 cases—controlled by indirect laryngoscopy, by direct inspection at a laryngo-fissure and by histological examination—yield a conclusion which is in direct opposition to that of Virchow and Semon. In other words, intrinsic cancer of the larynx is much more apt to take its origin in the centre or anterior portion of the vocal cord, or in the anterior half of the subglottic area, than in the posterior third of the larynx.

Pathology.

It is interesting to note that this conclusion appears to me to confirm the previsions which Jobson Horne based on his histological and pathological investigations of the larynx. In 1898, and again in 1907, he pointed out that tuberculosis attacks, by preference, that area of the larynx which is covered with columnar epithelium and is richest in glandular structure; whereas epithelioma shows a preference for that part of the larynx which is clad with squamous epithelium and is relatively free from glands. The posterior half of the larynx supplies the former conditions; the anterior half, which I have just shown to be the favourite site of intrinsic cancer, is lined with pavement epithelium, and is almost void of glands.⁹

As regards prognosis in reference to the site of an intrinsic cancer, it need hardly be pointed out that growths found on the upper surface of the cord, and those of a projecting or even semi-pedunculated character, are the most favourable. The more limited the growth the better is the prospect of completely removing it with a good margin of healthy tissue all round—that is in front and behind, above and below the cord, and also in the depth away from the glottis and toward the thyroid ala. These conditions are most likely to be met with in a growth of the middle of the cord, or of the anterior two-thirds; fortunately, as a reference to my statistics will show, these are the most usual sites.

If the anterior commissure is invaded the prognosis is not quite so good, though complete extirpation can still be effected, although with some sacrifice of the anterior part

of the opposite cord. As the growth approaches the arytenoid region the prognosis becomes less promising, and if the arytenoid itself is undoubtedly invaded it is probable that a hemi-laryngectomy or complete laryngectomy is the more promising operation.

When an epithelioma originates on the inner—that is, the glottic—surface of the cord the prognosis becomes less favourable, partly because there is lymphatic tissue in this area into which the cancer cells spread more rapidly than they do into the elastic tissue of the cord itself, and partly because the growth is already fairly extensive before it has appeared on the surface of the cord in sufficient amount to cause noticeable hoarseness and to be recognized clinically. Doubtless it is for these same two reasons that subglottic cancer is even more unpromising, and also because, as it dips down inside the crico-thyroid membrane, it is less circumscribed than when it lies entirely within the limiting barrier of the thyroid ala. In two cases I had to divide the cricoid cartilage to get below the downward extension of a subglottic epithelioma.

This darker prognosis with subglottic growths is confirmed by a reference to my 13 such cases: 7, or more than 50 per cent. of them, have died of recurrence. It is also striking to note that of these 13 cases the mobility of the cord was impaired or abolished in no less than 6, and that 4 out of the 6 are amongst the recurrences. This confirms the conclusion I enunciated in my paper of a year ago—namely, that impaired mobility of a cord is an unfavourable symptom.¹⁰

Treatment.

As the naked eye is not sufficiently trustworthy as a judge of the extent of an infiltrating growth, the entire cord should always be removed. Thus in one of my cases (No. 25) the pathologist reported that "the growth appears to be in the anterior part of the cord and to have burrowed backwards in the tissues beneath the surface epithelium, which is still intact over a considerable area of the growth." (The patient remains free from recurrence at the age of 77, five years after operation.) In a subglottic case (No. 24) the report of the pathologist was: "Specimen presented a deeply ulcerated new growth in subglottic region, immediately beneath the left vocal cord. A typical epithelioma. Though the growth arises beneath the cord, and the actual mucous membrane of the cord is still intact, the growth has invaded the substance of the cord beneath the mucosa." (The patient died of recurrence.)

CONCLUSIONS.

As Regards Usual Site of Origin.

1. Intrinsic cancer of the larynx originates on the vocal cords or in the subglottic area.
2. It has never been found in the posterior commissure (interarytenoid region), nor originating from the ventricular bands or the ventricle of Morgagni in 50 cases carefully examined both indirectly with the mirror and by direct inspection after splitting the larynx.
3. A malignant growth may originate on any part of a cord, but is more common in the central portion or anterior half than in the posterior area of the larynx.
4. As is now well known, an epithelioma originating in this region remains for a long time limited to the cord affected and the adjoining side of the larynx, but it may cross the anterior commissure, and, in later stages, it invades the arytenoid and the area to the outer side of it.
5. The inner surface of the cord may be affected primarily or by extension. The subglottic area may be invaded by a growth originating in a cord. But a cancer may also start below the level of the cords, in the subglottic area.
6. A subglottic cancer is much more common in the anterior than in the posterior half of the larynx.

As Regards Prognosis.

1. The superficial or projecting tumours of limited extent are the most favourable.
2. Those situated in the middle third or anterior half of the cord are more promising than those invading the anterior commissure in front or the arytenoid region behind.
3. Growths embedded in a cord, or extending into it below an intact mucosa are not so favourable.
4. An epithelioma extending along the inner margin of a cord is still less favourable.

5. Subglottic cancers are very unpromising as regards lasting cure by laryngo-fissure. They are frequently associated with impaired mobility or complete fixation of a cord.

As Regards Operation.

1. In every case, however limited the growth, the entire vocal cord should be excised from the anterior commissure up to and including the vocal process of the arytenoid.

2. The growth, with as wide a margin as possible of apparently healthy tissue all round it, should be removed in one mass; the excision should therefore go down to the lower edge of the subglottic area; above, it should pass through the healthy ventricular band; and externally it must include the perichondrium lining the thyroid ala.

3. To facilitate this the thyroid ala should be removed so that a laryngo-fissure is really a partial hemilaryngectomy.

REFERENCES.

¹ *Journ. of Laryng.*, xxviii, 1913, p. 184. ² St. Clair Thomson, *Intrinsic Cancer of the Larynx: Impaired Mobility of the Affected Cord in Diagnosis and Prognosis*, *Lancet*, 1920, ii, p. 183. ³ *The Throat and Nose*, fifth edition, London, 1899, p. 183. ⁴ *Op. cit.*, p. 183. ⁵ F. Semon, *Clinical Journal*, February 26th, 1896. ⁶ *Loc. cit.* ⁷ *Die Therapie der Kehlkopftuberculose*; München, J. F. Lehmann; 1907, p. 55; quoted by F. Semon, *Journ. of Laryng.*, xxii, 1907, p. 449. ⁸ *Journ. of Laryng.*, xxii, 1907, p. 561. ⁹ W. Jobson Horne, *Journ. of Laryng.*, xiii, October, 1898, p. 481; xxii, November, 1907, p. 561. ¹⁰ *Intrinsic Cancer of the Larynx: Impaired Mobility of the Affected Cord in Diagnosis and Prognosis*, *Lancet*, 1920, ii, p. 183.

HAEMATURIA AS SEEN BY THE SURGEON.

BY

ANDREW FULLERTON, C.B., C.M.G., F.R.C.S.I.,

SRGEON, ROYAL VICTORIA HOSPITAL, BELFAST, AND BELFAST HOSPITAL FOR SICK CHILDREN.

THERE are certain general rules laid down by clinicians to enable the practitioner to make a shrewd guess as to the cause and origin of haematuria in a given case. These rules are useful, but, as I shall show, they cannot always be relied upon for accurate diagnosis.

The cystoscope, combined in many cases with radiography, is indispensable for the examination of cases of haematuria from kidney, ureter, bladder, or prostate, and the urethroscope for doubtful cases of urethral haemorrhage. Indiscriminate enthusiasm, however, must be deprecated. A cystoscope or a urethroscope is not to be used in every patient who complains of urinary symptoms. The cystoscope may prove to be a dangerous weapon in certain cases of tubercle, malignant disease, enlarged prostate, sepsis, and incipient or established uraemia. It is well to proceed as far as possible along the ordinary lines towards diagnosis. The cystoscope or urethroscope may then be used to complete the examination.

General Considerations.

When blood is intimately mixed with the urine it is probable that the source of the haemorrhage is the kidney. This rule is not absolute. All we can say with certainty is that the blood is shed in small or moderate quantity, allowing intimate mixture with the urine before clotting has had time to take place. The cystoscope in a renal case may show a red efflux, the smoky or dark colour of the voided specimen being due to the change of oxyhaemoglobin into methaemoglobin by admixture with the acid urine. The following cases exemplify the difficulties of diagnosis:

A male, aged 56, presented himself with haematuria. The specimen passed was dark in colour. The only other symptom was frequency of micturition. Cystoscopy showed a malignant ulcer on the base of the bladder.

A man, aged 74, complained of difficulty and frequency of micturition, especially at night. The stream was small and the urine dark red; no clots were present. Instead of the expected enlarged prostate the cystoscope showed renal haematuria from the left side.

A clergyman, aged 56, stated that after a chill in 1919 he passed blood intimately mixed with the urine. He passed no clots, had no pain nor any dysuria. He had intervals of freedom with clear urine; later, tiny clots began to appear. The symptoms suggested haematuria of renal origin. Cystoscopy showed a papilloma on the right lateral wall of the bladder.

I could multiply cases to show the fallacy of depending for a diagnosis upon the character of the urine alone.

The presence of frequency of micturition is strongly suggestive that the site of the haematuria is the bladder or prostate; but the second case just mentioned, in which the haemorrhage came from the left kidney, shows how little dependence can be placed on this symptom. Frequency and bleeding in an old man will at once suggest enlarged prostate. The bleeding, as in the case just mentioned, may be from the kidney, or it may be from an unsuspected tumour, as in the case of a man, aged 70, who had symptoms of enlarged prostate. About a month before I saw him he had haematuria with clots and complete retention. Operation discovered not only an enlarged prostate but a papilloma as well. The haematuria was due to the papilloma and his other symptoms to the enlarged prostate.

If frequency of micturition and haematuria are combined with pain in the glans penis, scalding, and urgency, and if, in addition, pus and mucus are present, the diagnosis of cystitis is justified, but malignant growths and calculus must be excluded by direct observation.

Pain in the lumbar region, whether or not it culminates in renal colic, suggests an affection of the renal region of that side, but our expectations were belied in the case of a man, aged 49 years, who had haematuria with left lumbar pain. The cystoscope showed blood issuing from the right ureteral orifice.

If the haematuria is initial—that is, at the beginning of micturition—it comes, probably, from the prostatic urethra, or possibly from the anterior urethra. Blood issuing from the urethra, independently of micturition, comes from a source distal to the compressor urethrae. A small quantity may lie in the urethra and form a cast of the canal, which is swept out by the next act of micturition. Haematuria with massive clotting is often of bladder origin. During the late war, however, one of the most formidable complications of gunshot wounds of the kidney was secondary haemorrhage,¹ and in some of the cases blood was poured out in such quantity that the bladder was distended by large clots difficult to evacuate. In civil injuries of the kidney produced by crushes or strains, clots may form in the bladder. Again, in tumours of the kidney large clots may be passed, as in the case of a man aged 53, who complained that he passed numerous blood clots, about the thickness of the little finger. Cystoscopy showed blood issuing from the right ureteral orifice. Operation revealed a hypernephroma of the right kidney.

The size and shape of the clots may be of assistance in diagnosis. A long cast of the ureter is sometimes passed. Its length and thickness indicate its origin. More frequently shorter lengths are passed. Casts formed in the urethra are thicker and often show constrictions corresponding to those normally present in this canal.

Microscopical examination of the urine, especially if it can be carried out in the intervals between the attacks of bleeding, may be helpful. Mention need only be made of the presence of renal casts, cells from the bladder, ureter, or kidney, portions of tumour, pus cells, crystals, microorganisms, etc.

In the accompanying table I have grouped my cases according to the region affected; under each heading they are arranged in order of frequency. This has many disadvantages, but is convenient for my present purpose.

CASES OF HAEMATURIA.

Kidney.	Cases.
Tubercle of kidney (generally involving bladder secondarily)	100
Symptomless renal haematuria	47
Renal calculus	44
Pyelitis (including pyelitis and cystitis combined)	32
Renal tumours (including cysts)	21
Nephritis	19
Injury to kidney (excluding war injuries)	7
Renal colic (cause?)	5
Hydronephrosis	4
Pyonephrosis	4
Movable kidney	3
Horseshoe kidney	2
Oxaluria	2
Henoch's purpura	1
Accessory renal artery	1
<i>Ureter.</i>	
Ureteral calculus	9
Injury to ureter (excluding war injuries)	1

¹ Abstract of remarks opening a discussion on haematuria at the Ulster Medical Society, January, 1921.

<i>Bladder.</i>		
Cystitis	113
Tumours of bladder	...	72
Simple papillomata	...	41
Malignant growths	...	29
Fibromyoma	...	1
Rhabdomyoma	...	1
Vesical calculus	...	34
Ulceration of bladder	...	10
Tubercle of bladder secondary to tubercle of epididymis	...	5
Ruptured vessels of bladder	...	4
<i>Bilharzia haematobia</i> infection of bladder	...	2
Injury to bladder (excluding war injuries)	...	1
<i>Prostate.</i>		
Enlarged prostate (including malignant disease)	...	50
Prostatic abscess and prostatitis	...	3
<i>Urethra.</i>		
Papillomata of urethra	...	2
Calculus in urethra	...	2
		600

AFFECTIONS OF THE KIDNEY.

Tubercle of the Kidney.

Tuberculosis of the urinary tract is very common in the North of Ireland. Nearly 10 per cent. of all cases cystoscoped by me had urinary tuberculosis, and in 75 per cent. of these haematuria was present. In the overwhelming majority the primary focus, as far as the urinary tract was concerned, was the kidney. In my experience tuberculosis of the bladder, arising secondarily to deposits in the epididymis and testicle, is comparatively rare. If the ureteral catheter is used in all cases of tuberculosis of the epididymis the surgeon will be surprised to find how often the kidney is affected. I have seen tuberculosis of the epididymis make its appearance three months after the removal of a tuberculous kidney on the same side, and I have under my care at present a patient from whom I removed a tuberculous kidney, who has tuberculosis of the epididymis on both sides. While in France I saw, with Major Santos of the Portuguese army, a case in which the right kidney and ureter, the bladder, the prostate, the seminal vesicles and the urethra, including the meatus externus, were all infected with tubercle. Primary tuberculosis of the bladder, if it occurs at all, is so rare that such a diagnosis should not be made except after the most careful examination of all parts of the urinary tract.

The character of the haematuria in most cases of tuberculosis of the urinary tract resembles that found in bad cases of cystitis. The blood comes from the most part from ulcers on the bladder wall. Severe haematuria from the kidney is not, in my experience, frequent, but in the following case the blood was probably of renal origin:

A man, aged 27, first noticed blood ten years ago; it was not accompanied by any other symptoms and lasted for a week. He remained well for five years, when blood again appeared, accompanied this time by pain in the right lumbar region. Three years later he noticed a lump about the size of a pea behind the left testicle. Two years ago irritability of the bladder made its appearance. In January, 1920, I removed a tuberculous right kidney. The left epididymis was at this time hard and nodular, and the vas thickened. Both epididymides are now affected and there is a discharging sinus on both sides. This case has already been referred to.

Symptomless Renal Haematuria.

I have seen 47 cases of renal haematuria in which it was the only symptom of disease except for some renal colic in a few, due, no doubt, to the passage of small clots down the ureter. Some of these cases of symptomless renal haematuria have already perhaps proved, or may in the future declare themselves to be tumours, stones, tubercle, or other demonstrable affection of the kidney, but many will doubtless remain under the heading of what is known as renal epistaxis, renal haemophilia, essential renal haematuria, or symptomless renal haematuria. The haemorrhage in these cases is more or less severe, more or less persistent, and is seen to issue from one ureter. There are intervals of freedom in which the urine shows no departure from the normal. The patient may be otherwise in fair or even good condition, and the haematuria may persist for years without any serious impairment of the health. The bleeding is unilateral. No gross changes in the kidney can be found to account for it. Various hypotheses have been advanced to explain its occurrence. It

has been attributed to passive congestion, circumscribed or diffuse fibrous changes, disturbances of the vasomotor and sensory nerves, multiple microscopic calculi of the papillae, chronic papillitis, a varicose condition of the vessels of the papillae, adhesions, microbial infections, nephritis, etc. The following case will exemplify the difficulties of diagnosis:

A gentleman, aged 42, noticed, about ten days before I saw him, that his urine was bloodstained. There was no pain, except, perhaps, a slight uneasiness in the left side. The urine was dark in colour, and there were no clots, no pus, and no sugar. Both kidneys were easily palpable. Blood was seen to issue from the left ureter. The specimen obtained from the right side was normal in all respects. Shortly after this tubercle bacilli were found in the sputum, and the patient was sent to a sanatorium for some months. He remained free from bleeding for some years. In the summer of 1919 haematuria again appeared, and he passed occasional small clots. No enlargement of either kidney was found. The urine was free from tubercle bacilli, and casts were absent. X-ray examination was negative. The bleeding stopped, and he remained clear for nearly a year. It recurred in July, 1920, and continued till October. I then injected 10 c.cm. of 5 per cent. solution of nitrate of silver into the pelvis of the affected kidney, some of which immediately escaped into the bladder. The bleeding increased for a few days and then ceased. He remained well for a month, when another recurrence took place. The complication of tubercle bacilli in the sputum raised suspicions of tuberculosis of the kidney, but no sign of this has developed during the seven years I have had him under observation.

The following case is one of the most interesting I have seen:

A sailor, aged 30, two months after a fall on his right side on board ship, noticed that his urine was smoky. Professor Rovsing of Copenhagen found blood issuing from the right ureter. X-ray examination was negative. The right kidney was explored and nothing but adhesions to surrounding parts was found. The bleeding continued for three weeks and then cleared up for a few days to recur again for a week. Again it cleared up for three or four weeks and once again it recurred. On my examination the blood was seen to come from the left side. The specimen obtained from the side operated on by Professor Rovsing was absolutely normal. Three years later I again cystoscoped this patient, who had been bleeding off and on since my first examination. The blood was now coming from the right side.

Renal Calculus.

In 44 cases of renal calculus, out of 61 examined, the presence of blood was noted. The two cardinal signs of renal calculus are renal colic and haematuria, one or other or both of which may be entirely absent. Vomiting is also frequently present. In these days radiography will detect the smallest calculus, but in my earlier work, especially in the country, I had to depend on other methods for diagnosis. A history of renal colic with or without blood, the presence of pus, the presence of albumin, and a unilateral diuresis with a diminution of the specific gravity of the urine on the affected side afforded strong presumptive evidence upon which I often operated for stone. I should now be loath to operate without an X-ray examination. The symptoms of renal calculus are sometimes closely simulated by tuberculosis of the kidney, new growths, hydronephrosis, pyonephrosis, the presence of an accessory renal artery, hydatid cysts, and what I can only describe as ureteral spasm. I have often caused typical renal colic of a temporary character by the use of the ureteral catheter, and I have at least on one occasion relieved a patient by the mere passage of the same.

Pyelitis.

The essential feature of pyelitis is the presence of pus in the urine on one or both sides. The most usual cause is the *Bacillus coli communis*, but I have seen staphylococci, streptococci, and other organisms. Though severe haemorrhage may occur, the amount of blood present in my cases has been, as a rule, small, and not a dominant feature in the clinical picture. In acute cases the temperature is raised, and it is unwise to carry out any instrumental examination. After such an examination the temperature is likely to shoot up, and rigors may occur. Every case of pyelitis should be X-rayed. I have seen a patient treated by vaccines for months for persistent pyuria due to a stone in the pelvis of the kidney.

Renal Tumours and Cysts.

Under this heading there were 21 cases, including the following: Hypernephroma, by far the most numerous; malignant adenoma, sarcoma, malignant growths of the

abdomen involving the kidney by continuity, a case of hydatid cyst which I saw in France, congenital cystic kidney, a rare form of cystic kidney removed from a child aged 2 years, and one or two cases judged to be inoperable. In the space at my disposal I can only deal in a general way with this group. In the case of hydatid cysts and the cystic kidney removed from the child aged 2 years, the bleeding, though noticeable, was neither persistent nor serious. In a case of congenital cystic kidney the bleeding was so profuse as to threaten the life of the patient; as is well known, this type of tumour is nearly always bilateral, and it is therefore useless to remove one kidney.

In a case of sarcoma of the kidney the patient, a female child aged 3 years and 3 months, had severe haematuria, and screamed with pain on passing water, no doubt owing to the clots present in the bladder. Cystoscopy confirmed the diagnosis of haemorrhage from a tumour of the left kidney. A few days later I removed a sarcomatous kidney by the trans-peritoneal route. The patient died four months later from recurrence.

A man, aged 53, gave a history of having passed a stone after "terrible" renal colic. Twelve years later he presented himself with an indistinct swelling in the side previously affected with renal colic. In the previous illness he had had haematuria of slight degree. The urine was free from blood when I saw him for the swelling in the loin. I expected to find a stone in the pelvis of the kidney from the history, and also from the cystoscopic examination, which showed a diminished specific gravity in the specimen from the affected side. Operation revealed a malignant adenoma of the kidney.

In several of the cases of hypernephroma the bleeding was considerable and clots were passed. Some of them suffered from renal colic, and others had no other symptom but painless haematuria, at any rate in the early stages.

In cases of tumour of the kidney the earliest symptom may be a type of painless haematuria exactly similar to that described as "essential renal haematuria." I am not sure that every case of renal haematuria of doubtful origin should not be explored to avoid missing an early case of malignant disease. Many unnecessary operations would doubtless be performed, but some cases of tumour would be diagnosed in time to admit of successful removal with less chance of recurrence. The appearance of a tumour in the side shows that the disease is in an advanced stage. Radiography and pyelography may show earlier some alteration in the size or contour of the kidney, or in the pelvic shadow, and ought always to be resorted to in a doubtful case.

Nephritis.

I have examined 19 of these cases suffering from haematuria. In all, some other sign or symptom was present, such as casts in the urine, albumin when the bleeding was for the moment absent, cardio-vascular changes, albuminuric retinitis, oedema of the face and extremities, or some other indication of acute or chronic nephritis. These cases belong to the domain of the physician rather than that of the surgeon. Their chief feature, from a cystoscopic point of view, is the presence of blood on both sides. In 11 of my series this was the case. One of them was a case of trench nephritis, in another with severe renal colic and unilateral haematuria the late Dr. McQuitty made the diagnosis from the discovery of albuminuric retinitis. Some of these cases have cleared up completely.

Injury to the Kidney.

Besides the 56 cases of gunshot wounds of the kidney, fully reported elsewhere,¹ I have seen in civil practice 7 cases sufficiently mild to admit of cystoscopic examination. A comparatively slight strain is sometimes sufficient to injure the kidney and give rise to considerable haematuria. I have seen this occur in a patient who slipped on a plank and apparently bruised his kidney in the effort to right himself. With more severe injuries the presence of a perirenal haematoma, as in gunshot wounds of the kidney, is an outstanding feature and a help in diagnosis.

A young man, aged 18, was seen with Dr. Mann, of Dunnington. He fell across a drain, his shoulders resting on one bank and his feet on the other, so as to produce lateral flexion of the body, with the concavity to the right side. That the kidney on this side was injured was evident from haematuria with clots, a perirenal haematoma and pain. Cystoscopy showed blood issuing from the right ureteral orifice. Recovery without operation took place. In this case the kidney was probably crushed between the ribs and the ilium on the concave side.

It is important to know when to intervene in cases of renal injury. It is almost certainly fatal to operate on a bled patient. Blood transfusion, followed by immediate operation, saved lives during the late war.

Renal Colic without Obvious Cause.

In the 5 cases of this nature that I have seen the colic strongly suggested stone, but radiography failed to show any abnormal shadow. It may be, as Casper suggests, that spasm of the ureter occurs comparable to that of the oesophagus in hysterical people. In such cases the passage of the ureteral catheter might be tried, as in the case already mentioned.

Hydronephrosis.

Haematuria is not a cardinal sign of hydronephrosis, though it may be present. The chief signs and symptoms of this condition are pain, sometimes developing into renal colic with vomiting, and a tumour in the lumbar region which varies in size or even disappears altogether at times. The urine obtained from the affected side is of low specific gravity compared with that of the sound side. At times no fluid can be obtained owing to the block causing the hydronephrosis. In one case inspissated blood was seen by the cystoscope to be squeezed out from the ureter of the affected side like ointment from a tube. Bleeding had evidently taken place at some time into the sac of the distended kidney. By injecting opaque solutions like thorium nitrate or collargol into the pelvis of the kidney, and taking an X-ray photograph, the shape and the size of the pelvis of the kidney and its branches may be determined. If the cavity is large the opaque fluid may be so diluted that no definite shadow is seen.

Pyonephrosis.

The allied condition of pyonephrosis, of which I have had 4 cases giving a history of haematuria, is often diagnosed by the profuse discharge of pus which takes place at intervals from the distended kidney into the bladder.

In a case seen recently the urine had been clear and pronounced normal by our pathological department at the Royal Victoria Hospital. On cystoscopic examination I could detect no change in the ureter of the affected side, but on passing a ureteral catheter some way up clouds of pus were discharged by the side of the catheter into the bladder. The patient had suffered from severe attacks of renal colic. In the calyces of the distended kidney on removal a mixture of inspissated pus and blood was seen, and the colic may have been due to portions of this being passed along the ureter from time to time.

Movable Kidney.

It is well known that during Dietl's crises haematuria may occur, but I have only had 5 cases of movable kidney with haematuria sent to me for cystoscopic examination. In the first case, although the kidney was movable, pain was slight or absent. The specific gravity of the urine on the affected side was 1015, as against 1020 on the sound side. Blood was present in the jets from the affected side. Nephropexy cured the haematuria. In the second case the specific gravity was again lower on the affected side. The patient suffered from Dietl's crises. The late Dr. Hicks found the kidney surrounded by peritoneum which formed a mesentery for it. In the third case crises were present and there was considerable haematuria.

Horseshoe Kidney.

In 2 cases an exploration showed a horseshoe kidney. In the first there was a connecting band across the middle line between the lower poles of the kidneys. In the second case, which was under the care of Mr. Mitchell, I have no further note than that a horseshoe kidney was found. The symptoms in these cases resembled those of movable kidney, and were due, no doubt, to malposition of the organ with kinking of ureter or vessels.

Oxaluria.

Haematuria due to oxaluria is usually dealt with by the physician, but I have cystoscoped 2 cases in which the symptoms were attributed to the presence of numerous crystals of calcium oxalate in the urine. In one of these severe renal colic was complained of, but no stone was found on operation.

Henoch's Purpura.

I have cystoscoped one case of this affection. In addition to haematuria there were ecchymotic spots on the body, arms and legs, particularly about the joints. Haematemesis was present and moderate pyrexia. On cystoscopy blood-stained fluid was seen issuing from both ureters. The urine contained blood casts and granular casts.

Accessory Renal Artery.

I have published two cases of hydronephrosis due to this condition.³ In these no blood was found in the urine. I have, however, seen one other case in which haematuria was present, due, apparently, to the presence of an abnormal artery passing across the ureter to the lower pole of the kidney, "bow-stringing" the ureter, as Mr. Fenwick says, near its junction with the pelvis of the kidney.

AFFECTIONS OF THE URETER.

Ureteral Calculus.

In nine cases haematuria was due to ureteral calculus, which at the time of examination was arrested or actually impacted in the ureter. The symptoms resemble those of renal or vesical calculi, and are diagnosed by *x* ray with the opaque ureteral catheter in position. Stereoscopic radiograms should be taken, as shadows crossed by that of the opaque catheter may be in a different plane and altogether outside the region of the ureter. I adopt the method I suggested in France for locating foreign bodies in the neighbourhood of the kidney and ureter.⁴

Injury to Ureter.

In civil practice I have seen one case of injury to the ureter; it was caused by a fracture of the pelvis. I have published details of four cases seen during the war and caused by gunshot wounds. The haematuria is not, as a rule, serious. The most important diagnostic sign is urinary fistula in gunshot wounds and extravasation in the line of the ureter in civil wounds. I have used collargol injections with *x* ray to localize the lesions and assist in the diagnosis of these cases. The method has already been published in detail.¹

AFFECTIONS OF THE BLADDER.

Cystitis.

Haematuria was found in 113 cases of cystitis. In all it was moderate, and was often only discovered on microscopic examination. When visible it was generally of the terminal type, occurring at the end of micturition in the form of a few drops of blood with the last drops of urine. In some cases, and especially in those known as haemorrhagic cystitis, blood was mixed with the main part of the urine, although more pronounced in the last portion. During the war we became familiar with the haemorrhagic type of cystitis, with ecchymoses scattered over the mucous membrane.¹ In several of these cases streptococci were found. In ordinary circumstances, however, the most frequent organism was the *Bacillus coli communis*. Less frequent were staphylococci, *B. proteus*, gonococci, etc. In many cases, however, no bacteriological examination was made. I am not able to state definitely that in all of these cases the kidneys were free from infection. Cystitis is often due to a descending infection from the kidney. I have investigated a number of cases of cystitis which did not clear up with the ordinary methods of treatment, and in 17 pyelitis was present. These are included under the heading of pyelitis.

Tumours of the Bladder.

Some of the most severe cases of haematuria met with were due to tumours of the bladder. I have notes of 72 cases, and in most of them the haemorrhage is described as severe and associated with the formation of massive clots in the bladder. In some cases, however, the haemorrhage was trifling—at any rate, in the earlier stages.

A man, aged 38, complained of frequency of micturition and pain at the point of the penis. A little blood was passed on straining, and occasionally the act of micturition was suddenly arrested. These symptoms were strongly suggestive of stone. On passing the cystoscope, a pint of residual urine was drawn off. A small papilloma was seen to hang down over the vesical orifice of the urethra, suspended by a long pedicle. This acted as a ball valve, obstructing the flow of urine, and explained the patient's symptoms. The tumour was removed by suprapubic cystotomy.

A man, aged 54, noticed blood in his urine and slight pain in the left groin. He had some frequency of micturition during the day, but was not disturbed at night. There was also some pain at the point of the penis. The urine contained blood, but no pus. The cystoscope showed two small papillomata on the base of the bladder. These were removed by the high frequency current.

In other cases the bleeding was much more profuse, with much clotting, and in many there were multiple papillomata, extending all over the bladder. In the malignant cases sloughing of the free surface of the tumour and cystitis are more apt to occur, and the symptoms are correspondingly more severe.

The following case is so remarkable that I cannot refrain from mentioning it:

A woman, aged 51, had had the left breast removed for cancer about a year and a half before the present illness. She complained of blood in the urine; it was intimately mixed with the urine. There was a little frequency but no pain in the bladder region. There was some pain in the back, extending down the left leg. Cystoscopy showed at the apex of the bladder a sharply circumscribed circular ulcer about the size of a sixpenny-piece. The adjoining walls were drawn in folds towards the ulcerated area. Mr. Kirk operated and found an ulcer corresponding to the cystoscopic picture. The peritoneal aspect of the bladder was involved for an area rather smaller than the mucous membrane. Microscopically the ulcer proved to be scirrhus. In this case it is probable that cancer cells had dropped from the falciform ligament of the liver and taken root on the peritoneal aspect of the bladder.

The following case of fibromyoma is interesting owing to its extreme rarity:

A woman, aged 43, suffered from frequency with pain during micturition and haematuria with occasional clots. On cystoscopic examination I found a rounded projection on the right side about the size of a Tangerine orange; it was covered with normal mucous membrane, except at the inner edge where what looked like minute papillomata, or possibly mucous cysts, could be seen. I took the view that some growth in the pelvis was pushing the bladder wall inward, and referred the patient to a gynaecologist. Dr. Lowry found fibroids of the uterus, and a fibromyoma in the wall of the bladder quite free from the uterus.

The case of rhabdomyosarcoma is also interesting because very uncommon:

The patient had symptoms of cystitis for about a year. Cystoscopic examination showed on the base of the bladder, between the ureteral orifices, an ulcerated area covered with a whitish thick shreddy slough. The bladder was opened by the transvaginal route and a hardish ulcer, about half an inch in diameter, was excised. The excised area included the mouths of both ureters. Professor Symmers pronounced the ulcer to be malignant, a rhabdomyosarcoma showing muscle fibres with striation (foetal type). Also some cells round vessels (perithelioma). I examined the patient a year and a half later; the ureteric orifices were wide open, and the growth had not recurred.

Vesical Calculus.

Out of 46 cases of vesical calculus examined the presence of blood is mentioned in 34. This varied from a microscopic to a moderate degree of haemorrhage. The bleeding generally occurred at the end of micturition. The signs of stone in the bladder are sometimes obscure and the calculus is occasionally only accidentally discovered. Cases of severe cystitis are often labelled stone, and the symptoms are very similar. As a matter of fact, the symptoms of stone are due in a large measure to the cystitis which generally accompanies it. Sudden cessation of the stream is not diagnostic of stone. In cystitis spasm may occur at the neck of the bladder and the stream may be arrested, and in certain cases of stone this symptom may be entirely absent. Pain at the point of the penis is not confined to stone. It is present in cystitis. *X*-ray examination will detect a calculus, but I have seen a shadow in the pelvis diagnosed as stone which proved to be extravasical, and probably due to a deposit of tubercle in the ovary or broad ligament. Sir Almreth Wright asked me to see this case in France. The radiographer of the Harvard Unit had diagnosed a stone in the bladder. I could not find it on cystoscopic examination, but bimanually I could feel a hard mass in the pelvis. I subsequently removed a tuberculous kidney in this patient. The sound will detect most cases of stone, but the only satisfactory method is cystoscopy.

Ulceration of the Bladder.

Ulceration of the bladder is seen most frequently in tubercle of that organ and in malignant disease. Superficial ulceration is sometimes seen in cystitis. I have had

one case of extensive ulceration in which the mucous membrane of about a sixth part of the bladder sloughed, leaving the muscular coat exposed. This was attributed to mercury perchloride solution used to wash out the bladder, but it may have been due to an infection. Unfortunately a bacteriological examination was not made. The haematuria in the ten cases of ulceration of the bladder not due to tubercle or malignant disease, mentioned in the notes, was of a moderate character.

Rupture of Bladder Vessels.

The vessels of the mucous membrane of the healthy bladder very rarely rupture. In a few cases severe straining appears to be capable of causing this accident. I have had four cases in which such rupture had apparently taken place. One of these occurred in a case of retroverted uterus.

Bilharzia haematobia.

I have only cystoscoped two cases of bilharziasis of the bladder; both occurred in soldiers lately returned from the South African war. In the first case the symptoms came on nine months after the patient reached South Africa; he noticed a little blood at the end of micturition, but he had no other urinary symptoms. The urine was examined by Professor Symmers, who found the characteristic ova. The following appearances were seen with the cystoscope: The mucous membrane in places was dull red, thick and raised. Scattered over it were small raised white nodules, varying in size from that of a pin's head to that of a hemp seed. The little white bodies resembled pustular acne spots on the face. Small breaches of surface and haemorrhagic patches in the neighbourhood of these nodules were seen in some places. The appearances in the second case were somewhat similar.

Injury to the Bladder.

Injuries of the bladder are not infrequent in cases of fractured pelvis in civil life, but I have only cystoscoped one such case:

The patient was a railway porter who had been caught between a railway carriage and the platform. On admission to hospital he passed blood. The abdomen had been explored for ruptured bladder. There was some subperitoneal extravasation of blood on the left side of the bladder, but the peritoneum was not torn. Portions of the bowel and omentum were echymosed. The patient was cystoscoped a fortnight after his injury. There were a good many clots in the bladder. Several dark-coloured rents were seen in the left wall. The mucous membrane at the edges of these rents was pale, almost dead white. The rents gaped slightly. While I was examining the patient a gush of haemorrhage took place and obscured the view. This may have been from the right kidney, as I understand that Mr. Kirk later removed a ruptured right kidney.

AFFECTIONS OF THE PROSTATE AND URETHRA.

Enlarged Prostate: Prostatitis.

In some cases of enlarged prostate the haematuria is due to associated cystitis. The haematuria in these is similar to that described under the heading "cystitis." More important from the point of view of treatment is haemorrhage from the vessels of the prostate itself, or of the mucous membrane covering its projection into the bladder. This may be so severe as to fill the bladder with clots, which block the internal meatus and the eye of the catheter used for the relief of retention. The practitioner is in a difficulty when confronted with such a case. A specially constructed catheter, which can be opened at the tip, when the latter has entered the bladder and been pushed up to a region free of the clots, may be used, or it may be necessary to perform cystotomy, or even to remove the prostate as an emergency operation if the patient's condition is otherwise favourable.

The haemorrhage in the cases of prostatic abscess was not of great significance. In the prostatitis case the blood was seen in the seminal fluid after emission.

Papillomata of the Urethra.

I have notes of two cases of severe bleeding from papillomata of the urethra. In the first the bleeding was profuse and independent of micturition. Its source was detected by the urethroscope after the injection of adrenaline. Three or four small papillomata, each about

the size of a corker pin's head, were seen 2½ in. from the external meatus at a somewhat narrowed part of the urethra. Just behind this a large calibre stricture was seen. The papillomata were removed by a sharp curette, and the raw area was touched with a strong solution of nitrate of silver. The bladder, curiously enough, was full of blood, which had apparently passed back through a relaxed sphincter. On washing out, the bladder and ureteral orifices were seen to be healthy. The second case was almost exactly similar. The papillomata were removed by urethral forceps and the canal was packed for a few hours with strips of gauze.

Stone Impacted in the Urethra.

There were two cases of impacted stone in the present series. In the first the stone was situated just inside the meatus externus, and was easily removed. In the second the stone was detected in the prostatic urethra by the urethroscope. It was pushed back into the bladder and removed by litholapaxy. The bleeding in both these cases was trifling.

TREATMENT.

In cases of any severity the patient should be kept at rest, and morphine, if not contraindicated, should be administered. Calcium chloride or lactate should be given for a few days. Preparations of ergot and hazeline may be tried, and sterilized horse serum, or inhalations of CO₂, as recommended by Wright, may be of use in some cases. The underlying cause, if discoverable, will, of course, require attention. Tumours, calculi, tuberculous kidney, etc., demand surgical treatment in suitable cases. The bleeding in cystitis itself will be dealt with by urinary antiseptics and lavage of the bladder. Renal haematuria of the type known as "essential" may tax the resources of the surgeon to the utmost. Section of the kidney, decapsulation, fixation of a movable kidney, incision into the pelvis, with direct attack on the papillae, etc., and injection of silver nitrate solution or adrenaline, are among the methods used. Removal of the offending organ is a radical procedure, only justifiable if all other methods fail and the patient's life is in danger. To control haemorrhage of bladder origin, pending more radical measures, adrenaline may be employed. A slower but more lasting remedy is to irrigate with silver nitrate solution. Failing this, the bladder may have to be opened and the cause dealt with, or, if that is not feasible, a large tube may be inserted and irrigation with hot water carried out. In certain cases of haemorrhage into the bladder, with massive clotting, an evacuating catheter similar to that used for litholapaxy may be used to remove the clots. It may even be necessary to perform cystotomy to clear out the clots. Packing the bladder is an unsatisfactory proceeding. If resorted to, a way of escape must be provided for the urine, and the ureteral orifices must not be blocked. Raising the foot of the bed is helpful in some cases. Bleeding from the anterior urethra can be arrested by pressure. Bleeding from the bulbous or membranous urethra may be controlled by pressure applied to the perineum.

Finally, no patient ought to be allowed to die of haemorrhage without an attempt being made to restore him by transfusion of blood or intravenous injection of gum saline solution.

REFERENCES.

¹ *British Journal of Surgery*, vol. v, No. 18, 1917. ² *Ibid.*, vol. vi, No. 21, 1918. *Ibid.*, vol. i, No. 2, 1913. ³ *Ibid.*, vol. iv, No. 14, 1916.

THE Union of International Associations of Brain Workers will hold a congress at Brussels from August 20th to August 22nd. The union was established in 1910. Before the war 250 associations of various kinds had joined it; of these 100 remained faithful, and took part in a congress held last year. Among the subjects to be discussed next August will be the steps which should be taken by brain workers to assert their rights in relation to both capital and labour, the difficulties encountered in the dissemination of periodical literature, and the steps which the League of Nations can take to carry out its avowed intention of helping brain workers. The subscription to the congress is 20 francs, and full particulars can be obtained on application to the Secrétariat du Congrès International du Travail Intellectuel, Palais Mondial, Parc du Cinquante-naire, Bruxelles.

THE SCHICK REACTION:

A CLINICAL TEST FOR THE DETERMINATION OF
SUSCEPTIBILITY TO DIPHTHERIA.

BY

GLADYS WARD, M.D., D.P.H. EDIN.,

ASSISTANT MEDICAL AND CHILD WELFARE OFFICER, DEPTFORD.

*Preparation of the Toxin and Technique of the
Injection.*

For purposes of the Schick test¹ a toxin which has been ripened for at least a year, and then carefully standardized by determining the minimal lethal dose for a 250-gram guinea-pig, should be used. The bulk toxin will keep its strength very well if a ripened toxin is used. A dilution of the toxin is then made, of such strength that 1 c.cm. contains one-tenth of a minimal lethal dose. The amount actually injected in the test is 0.2 c.cm. of this dilution—that is, one-fiftieth of a minimal lethal dose.

To make the injection it is essential to have a short, sharp-bevelled needle which fits accurately on the syringe. A 1 c.cm. Record syringe is found most convenient. The flexor aspect of the right forearm just below the bend of the elbow is the selected spot. The arm having been first cleaned with ether or spirit, the skin is made taut between the forefinger and thumb of the left hand, and 1.5 c.cm. of the diluted toxin is injected intracutaneously. The result is absolutely useless if the injection be made subcutaneously. When done correctly a raised white wheal with a definite edge, and on which the pores of the skin are visible, is produced. Finally, if the test has been successfully performed, it should be possible to express a small drop of blood-stained serum from the site of the injection.

A true positive reaction is clearly visible at the end of twenty-four hours as a clearly circumscribed red area, generally about $\frac{1}{2}$ inch in diameter, and accompanied by slight infiltration. This increases in intensity for the next three or four days, and then gradually fades, leaving a still distinct area of pigmentation and scaling. This pigmentation is generally faintly visible at the end of four or five weeks, and thereafter disappears. There is no general reaction. People who are using their arms a great deal may complain of some stiffness and local irritation.

A pseudo-reaction appears earlier, reaching its height in from twenty-four to thirty-six hours. It is not definitely circumscribed, and often shows a secondary areola, which fades off into the surrounding skin. The reaction begins to fade at the end of thirty-six hours, and has generally quite disappeared at the end of seventy-six hours, leaving no scaling; but, occasionally, a faint bluish mark persists on the skin for some days. The patient complains more frequently of stiffness and soreness of the arm, and in one or two cases a general reaction (headache, vomiting, etc.) has been noted.

A reaction is said to be negative when there is absolutely nothing to be seen at the site of the injection at any time.

The majority of the readings referred to in this paper were made at twenty-four hour, seventy-six hour, and seven-day intervals, the reasons for these intervals being as follows:

(a) At the end of twenty-four hours both the true and the pseudo-reaction, should it be present, are well marked.

(b) The pseudo-reaction has begun to fade at the end of forty-eight hours, and by the time seventy-six hours have elapsed has generally completely disappeared, thus rendering the second reading much simpler.

(c) The third reading was taken at the end of a week or ten days. I consider the latter quite reliable, and more convenient when dealing with patients in a general hospital.

The reading of the different reactions, after a short apprenticeship, presents little difficulty, except in cases complicated by a pseudo-element, and in these cases a "control" test may be done at a site on the left arm corresponding to the original test on the right. The control toxin is heated to 75° C. for ten minutes, whereby the specific toxin is destroyed, and the proteins, to which the pseudo-reaction is due, are left unchanged.

Careful records should be kept—these to include the name, age, and address of the patient, the date of injection, subsequent readings, and final remarks and results of each case.

It is, of course, essential that the toxin be reliable. I was fortunate in obtaining from Dr. Claude B. Ker one which had been prepared by Dr. R. A. O'Brien, and which had been proved to be entirely satisfactory.

The test depends on a local irritant action of minute quantities of diphtheria toxin given intracutaneously. A negative reaction indicates that the individual is possessed of a necessary number of antibodies to neutralize the

toxin, and is therefore immune to the disease at the time when the test is made. According to Schick himself a negative reaction indicates at least 1,30th of a unit of antitoxin per cubic centimetre of blood—that is, sufficient to protect against diphtheria. Von Behring maintains that 1 100th unit is sufficient. A positive reaction indicates that the individual tested does not contain sufficient antitoxin in his blood to render him immune. A pseudo-reaction is probably a local sensitization phenomenon of a protean character, since a similar reaction can be produced with toxin heated to 75° C. for five minutes, or with dilutions of the autolyzed substance of the diphtheria bacillus in which no toxin is present.

Influence of Age on the Schick Reaction.

The following table has been compiled from tests done in the Royal Hospital for Sick Children and in Craighlockhart Poorhouse Hospital, Edinburgh.

Age.	Number.	Negative.	Positive.	Percentage Positive.
0 to 6 months	25	23	2	8
6 months to 2 years ...	41	21	20	50
2 to 5 years	26	10	16	61
5 to 10 years	44	30	14	34
10 to 15 years	14	10	4	28
Total	150	94	56	37

Here we find that the greatest number of positive Schick reactions occurred in children between the ages of 6 months and 5 years. This we know to correspond with the age incidence of diphtheria.

The following is a table showing the number of deaths from diphtheria in this country in 1917.

All Ages.	— 1	1 —	5 —	10 —	15 —	25 —	35 —	45 —
648	42	404	145	33	6	7	3	8

From this we see that no less than 63 per cent. of the total number of deaths occurred between the ages of 1 and 5 years, and it is interesting to compare this figure with that quoted in the previous table of children between the ages of 2 and 5 years who give positive Schick reactions, the percentage of these being 61.

Influence of Concurrent Disease on the Reaction.

The following table gives the results in the scarlet fever wards:

Age.	Number.	Negative.	Positive.	Percentage Positive.
0 to 1 year	0	0	0	0
1 to 2 years	2	0	2	100
2 to 5	17	0	17	100
5 to 10	47	21	26	55.3
10 to 15	30	11	19	63
15 years and over ...	54	34	20	37
Total	150	66	84	55

These results, though comprising too small a number to be of great value, correspond fairly closely with those published by Dr. Leete² last year, his total percentage of positive results being 57.2.

Comparing the results between children tested in the scarlet fever wards and in the wards of a general hospital we find in the former 66 per cent. positive between the ages of 6 months and 15 years, in the latter only 37 per cent. For a long time, moreover, it has been a recognized fact that, in spite of all precautions, cases of diphtheria occur in the scarlet fever wards more readily than in others. Zingher³ suggests that there may be a destruction of the natural diphtheria antitoxin during an attack of

scarlet fever, while Von Behring has suggested that there is a temporary loss of natural immunity to diphtheria during the acute febrile stage of the disease.

Among the cases studied at the Sick Children's Hospital the actual disease from which the child was suffering at the time did not appear to have any definite bearing on the reaction, but the "acuteness" or "chronicity" of the case apparently bore a close relationship. The percentage of positive Schick reactions is given under the following headings:

Respiratory diseases (not tuberculous), 56.25 per cent. Alimentary diseases (not tuberculous) 50 per cent. Tuberculosis 45.5 per cent. Nervous disorders 33.5 per cent. Rheumatism 27 per cent. Rickets 16.6 per cent. Diseases of kidney and bladder 16.6 per cent. Congenital syphilis 14 per cent.

Another series of cases was then taken and divided into two groups—acute and chronic—care being taken to exclude entirely all such cases as could not be definitely classified.

The "chronic" cases included chronic tuberculous infections, long-standing empyemas, congenital syphilis, etc., while the "acute" were chiefly made up of pneumonia, acute bronchitis, acute gastro-enteritis, etc. The results were as follows:

Of chronic cases 28 per cent. were positive.
Of acute cases 60 per cent. were positive.

We see, therefore, that the number of positive Schick reactions found in the acute cases was as high as that found among scarlet fever patients. The figures obtained by Dr. Leete, in the 500 scarlet fever cases tested by him in the Edinburgh City Fever Hospital, show that between the ages of 1 and 15 years 60 per cent. were positive; my own figure is somewhat higher—namely, 67 per cent. "Acute general cases" in the same age group also gave 60 per cent. positive Schick reactions.

It was interesting to note, moreover, in several cases of *tabes mesenterica* tested, that most of those who came in almost in *extremis* and were "hopeless" from the first gave a strongly positive reaction, whilst those who were less severely infected and left hospital "improved" gave a negative reaction. Another interesting example was supplied by two sisters who were in the ward at the same time suffering from dysentery.

One was aged 7, the other 8, and neither of them had had diphtheria. The infection in both cases was by the *Shiga* bacillus. The younger, who was the more severely ill on admission and subsequently died, gave a strongly positive reaction, whilst the elder, who was only mildly infected and made a good recovery, gave a negative reaction.

It has been noted by various observers that immunity or non-immunity to diphtheria runs in families. Is not this case, then, very suggestive of the fact that any acute infection may cause a temporary loss of natural immunity, and that the high percentage of diphtheria cases occurring in scarlet fever wards may also be explained on these grounds?

It has been suggested that the Schick reaction might be due to a general reaction on the child's part to any toxic material. Dr. Ellsworth Moody⁴ successfully established this as a fallacy by testing 180 children in the St. Louis Children's Hospital with intradermic tuberculin and diphtheria toxin, and by finding similar reactions in only 34 cases.

Influence of Pregnancy on the Reaction.

Report on a series of 50 maternity cases. With the exception of three or four all the tests were made during the first week of the puerperium, the babies' ages varying from two to eight days.

Mother and baby negative	45
Mother and baby positive	1
Mother negative, baby positive	1*
Mother positive, baby negative	3

* Reaction doubtful (baby 4 months).

That is, 90 per cent. of the mothers, and 96 per cent. of the babies, gave a negative reaction. Controls were done at the same time with toxin which had been heated to 75 C. for ten minutes. We found that no less than 30 (that is, 60 per cent.) of the mothers gave pseudo-reactions, 27 of them occurring in the immune mothers and 3 in those who gave positive Schick reactions. Three of the 27 who showed a pseudo-reaction had had diphtheria in infancy.

The actual technique in newly-born infants presented some difficulty, but only those results have been used in which a quite satisfactory injection (showing the well marked white wheal, etc.) was made. The natural

erythema of a young infant's arm rendered one or two readings doubtful at first, but complete absence of pigmentation or scaling at the end of a week led one to the diagnosis of a negative reaction.

Finding 90 per cent. of negative reactions in puerperal women as compared with the 75 per cent. quoted by Schick in the records of the Willard Park Hospital, and the 67 per cent. found by myself in scarlet fever patients, raises once more the long-vexed question of the possibility of pregnancy conferring temporary immunity to disease. It is, however, quite impossible, in a short paper such as this, to enter into the controversial literature on that subject.

The large number of pseudo-reactions (90 per cent.) found among pregnant women. I think, endorses the view that the pseudo-reaction is of the nature of a local anaphylaxis, the woman in this instance being sensitized by the protein absorbed through the placenta.

Immunity in the New-born.

In the 50 odd cases tested only one baby gave a definitely positive reaction, and one in a 4 months baby was doubtful. Schick, however, found 7 per cent. of positive reactions in a series of nearly 300 tests made on new-born infants. According to Zingher,⁵ the antitoxin of the infant obtained from the immune mother lasts for about six to nine months after birth. Kazzowitz and Groer⁶ found that 84 per cent. of mothers and their new-born infants contain a body which has the property of neutralizing diphtheria toxin, and thus they identified with diphtheria antitoxin. This is present in mothers and infants, and, presumably, is transmitted through the placenta to the foetus, and because of its frequency is regarded as a physiological phenomenon. The fact that children of the same family give the same reaction also suggests an hereditary factor, which in the absence of infections by the *Klebs-Loeffler* bacillus gives rise to the presence of the so-called natural antitoxin. That nearly all infants are born with a sufficiency of antitoxin to render them immune to diphtheria is an established fact; why it should persist in some children and disappear in others is still unexplained. Zingher tells us that only a few infants retain their maternal immunity after the twelfth month, and probably all lose it before the eighteenth month of life.

Our next consideration is that of the establishment of an artificial immunity, which will replace or supplement the natural, and carry the child safely through those years when he is most susceptible to the disease.

Active Immunization of Infants.

As the immunity conferred by the mother varies in the length of time it persists—disappearing in most cases at the end of six months, yet persisting in some children till the end of the second year of life—it is obvious that a negative Schick reaction is not reliable until after the second year. Park and Zingher⁷ adopted the following procedure in institutions:

Inmates six months or more in age were Schick-tested. If positive they were immunized by injecting subcutaneously three doses of toxin-antitoxin mixture. Those giving a negative Schick reaction were retested every three months up to the third year because of the gradual loss of passive immunity in many. Those giving a positive test at any time were immunized. After the administration of the immunizing doses (work done by Dr. Blum) immunity developed in from three weeks to three months, and lasted more than two and a half years.

Speaking at the New York Academy of Medicine in 1918 Zingher said: "In children over 2 years of age a negative Schick test indicates a permanent immunity to diphtheria. Fully 99 per cent. of the children over 2 years of age who give a negative Schick reaction continue, when retested at a later period, to give a negative reaction."

He finds that those who gave a positive Schick reaction and were injected with toxin-antitoxin were slow in producing antitoxin. Only 30 per cent. were found to be immune at the end of three weeks, but the Schick test in the other children became fainter and fainter and eventually became negative in most instances.

Later Schick tests showed that 95 per cent. of these children had become immune. He has also immunized children by three doses of toxin-antitoxin and found that they gave negative Schick reactions when retested two and a half to three years later. He recommends that all positive reactors under 18 months be given three doses of toxin-antitoxin, each of 0.5 c.cm., one week apart; and that of the children over 18 months of age, and of adults, only those who give a positive reaction

should be immunized with toxin-antitoxin. They should have three doses of 1 c.cm. one week apart. Young children show no reaction.

In 1916 Park and Zingher⁶ presented a paper based on a series of over 1,000 cases that had been actively immunized with diphtheria toxin-antitoxin. These susceptible individuals were selected by means of the Schick test out of a total of about 10,000 children and adults in ten different institutions. The mixtures of toxin-antitoxin that were used for immunization were either neutral (66 to 70 per cent. L.+ to each unit of antitoxin), or slightly toxic (80 to 90 per cent. L.+ to each dose of antitoxin) to the guinea-pig. The dose was varied from 0.5 c.cm. to 1 c.cm. and the number of injections from one to three. The injections were made subcutaneously at intervals of seven days.

The retests with the Schick reaction showed that only 30 to 40 per cent. became immune three weeks after the first injection, about 50 per cent. at the end of four weeks, 70 to 80 per cent. at the end of six weeks, and 90 to 95 per cent. at the end of eight to twelve weeks.

The best results were obtained with the full immunization consisting of three injections of 1 c.cm. each, given at weekly intervals. The duration of the active immunity was studied in a group of children that was followed up for over one and a half years; these cases showed that the active immunity persisted for at least that length of time. It is possible that the immunity induced by the injections of toxin-antitoxin started a combined cellular production of antitoxin, which would have otherwise appeared much later in life. The L.+ dose of toxin is the amount which, when mixed with 1 unit of antitoxin and injected into a 250-gram guinea-pig, will cause its death at the end of four days.

Conclusions.

1. The Schick test has given us very definite data as to which years are the most dangerous with regard to diphtheria infection in a child's life. These are between 6 months and 6 years, while the periods of lowest susceptibility appear to be under 6 months and over 15 years. These results are endorsed by clinical experience.

2. It is of great value in deciding the difficult question of whether a patient is a carrier or is really suffering from diphtheria. For example, a case of streptococcal tonsillitis in a diphtheria carrier would by culture alone be thought to be one of diphtheria. If a Schick test were done on such a case no doubt would be left—in the case of the test being negative it would be treated as a carrier, and if the reaction were positive, as a case of diphtheria. Similarly in a case with a nasal purulent or sanious discharge the same difficulty would arise and a Schick reaction here too would indicate the line of treatment to be followed.

3. It has, perhaps, its greatest value in showing us to whom, among persons exposed to infection (for example, contacts, doctors and nurses), we may safely omit to give antitoxin—thus greatly minimizing the risk of anaphylaxis and also saving pain and expense. When possible, only those nurses who give a negative Schick reaction should be employed in diphtheria wards.

4. We are able by means of the Schick test to ascertain, in cases which have previously had the disease or have had antitoxin, to what extent their immunity persists, and whether they have sufficient antibodies to overcome a fresh infection.

5. Lastly, it has supplied us with a basis on which to build new immunizing methods, which have given such encouraging results in America that we feel justified in looking forward with confidence to the day when diphtheria will be a disease well under our control, and the infant and child life of this country robbed of one of its chief horrors.

I wish to express my thanks to Dr. Claude B. Ker for his guidance in doing this work, and for permission to publish the results. I also wish to thank Dr. Stewart Fowler, Dr. Lamond Lackie, and Dr. H. Gibson for giving me opportunities of carrying out the tests in their respective wards.

REFERENCES.

- ¹ Schick, B., *Muench. med. Woch.*, 1913, ix, 2608. ² Leete, H. M., The Schick Reaction, *Lancet*, January 24th, 1920. ³ Zingher, *Amer. Journ. Dis. Children*, 1917. ⁴ Moody, Ellsworth, *Journ. Amer. Med. Assoc.*, 1915, lxiv, 15. ⁵ Zingher, *Amer. Journ. Dis. Children*, 1918, xvi, 19. ⁶ Kazzowitz and Groer, *Jahrbuch für Kinderheilkunde*, 1913. ⁷ Park and Zingher, *New York Med. Record*, 1918, xciv. ⁸ Park and Zingher, *New York Med. Record*, 1916, lx. ⁹ Park and Zingher, *Archives of Pediatrics*, xxi, 481.

A MONUMENT was recently erected in one of the public parks of Madrid to Dr. C. M. Cortezo, the Spanish physician and politician, who is editor of the *Siglo Médico*, in recognition of his long philanthropic and public activities. At the inauguration ceremonies, in response to many speeches, Dr. Cortezo said that he accepted the tribute only as homage to the medical profession.

THE TREATMENT OF SYPHILIS IN MACEDONIA ON ACTIVE SERVICE.

BY

TREVOR HAYMAN FOWLER, M.R.C.S., L.R.C.P.LOND.,

CAPTAIN (LATE R.A.M.C.),

LATE SPECIALIST IN VENEREAL DISEASE, BRITISH SALONICA FORCE.

The experience of four and a half years in the army, the greater part of which time was spent in the diagnosis and treatment of venereal diseases, may justify a few remarks upon the methods employed in dealing with syphilis in Macedonia during the late war. I soon became impressed, first, with the importance of making a definite diagnosis as early as possible, and secondly, with the danger of the policy of applying local treatment to a venereal sore and awaiting results.

The hospital for venereal diseases contained some 300 beds, of which roughly a third were set apart for patients suffering from syphilis. Cases admitted to hospital with no other signs beyond a venereal sore were treated as follows: The sore was scraped and the exudate transferred to a microscope slide, a film made, stained by the Giemsa method, no other being at our disposal, and examined. If deemed advisable, the blood serum was tested by the Wassermann reaction, which was regarded as a help to diagnosis, but not relied upon alone, nor was it allowed to outweigh clinical evidence. Cases which left no room for doubt clinically were not necessarily subjected to the microscopic search for the *Spirochaeta pallida*, or to the Wassermann test. It is well perhaps to mention this fact, because in an article which appeared in the *Practitioner* for December, 1920, upon the Wassermann reaction, by Dr. C. Lundie, it was stated that in the army "a diagnosis of syphilis is not allowed, except when the *Spirochaeta pallida* is found or the Wassermann reaction is positive, and *per contra*, a cure is not admitted until both have become negative, a result in the case of the Wassermann sometimes impossible to attain."

The diagnosis having been made the patient was at once put under treatment, the usual course consisting of:

- (1) A weekly injection (intramuscular) of mercury.
- (2) Daily mercurial inunctions.
- (3) A weekly injection (intravenous) of "606" (salvarsan, kharsivan, diarsenol, galy), 0.3 gram, or a fortnightly injection 0.6 gram.
- (4) The urine was tested weekly, and treatment regulated thereby.
- (5) The patient was weighed at the commencement of treatment and at stated intervals throughout the course.

A rigid régime was insisted upon before and after the "606" injections; the reaction was usually slight, sometimes there was none. No cases of arsenical dermatitis occurred, and no suppurations ever followed the mercurial injections. Iodides were frequently given, but they did not form a part of the routine treatment. They were never used except in conjunction with mercury, not being regarded in themselves as a cure for syphilis.

Patients who had had repeated attacks of malaria, or who had suffered from dysentery or severe diarrhoea, and who had become debilitated thereby, did not make good subjects for this intensive treatment. As a rule mercury was withheld in these cases, at first altogether, and "606" administered in doses of 0.3 gram. If, as was usual, improvement took place, mercury was injected cautiously, a careful watch being kept for albuminuria or diarrhoea. A great many cases showed a mixed infection, due either to superimposed sepsis, or to the original sore containing pyogenic organisms. Suppurating inguinal glands were treated by simple surgical methods and were incised when "ripe"; at one time the plan of excising the glands before the skin had become involved was adopted; we found it tedious and without any appreciable advantages. The average stay of a patient in hospital was five to six weeks.

Each patient on leaving hospital was given a slip of paper which he was told to hand to his medical officer; whether this was always done is open to doubt. The advice given was to take one pill of hyd. c. cret. gr. ij each night for three months, to leave off for one month, and at the end of that month to have the blood tested by the

Wassermann reaction; he was told that if this was negative he should go on again exactly in the same way—that is, to take the pills for a further three months, to leave off for a month, and at the end of that month to have his blood tested again, and so on for at least twelve months. He was told that if the Wassermann reaction was at any time positive he should act according to further medical advice; the fact that the reaction was positive not being taken, in the absence of any signs of activity, as proof that a further course of intensive treatment was necessary or advisable.

Although we did not claim to "cure" after so short a course of treatment, we could claim that after a few weeks our patients were fit to carry on their duties in the trenches or elsewhere, which after all was an important matter in such a crisis.

RETROGRADE CATHETERIZATION FOR IMPERMEABLE STRICTURE OF THE URETHRA.

BY

W. J. FOSTER, F.R.C.S. (ENG.),

SURGEON, ROYAL BERKSHIRE HOSPITAL, READING.

THE operation here described is proposed as a substitute, in suitable cases, for Wheelhouse's operation, because it is easier to perform and gives better results from the patient's point of view.

Severe stricture of the urethra with retention of urine in the male is not as common in Reading as in London, but a few cases are admitted to the Royal Berkshire Hospital every year. Most of them can be treated by rapid dilatation under an anaesthetic, and quickly discharged from the wards to out-patients. Frequently before admission attempts have been made to pass a catheter, and the patient arrives with false passages and bleeding from the penis. In these cases I have the bladder aspirated above the pubes two or three times and try what rest, hot baths, and a free purge will do. Sometimes it is possible in a few days to pass a catheter and dilate the stricture. If this fails the patient is anaesthetized and a variety of catheters and sounds are tried. If I fail to get in even a filiform bougie the usual proceeding has been to do Wheelhouse's operation; but when there are false passages and a bleeding urethra this is often very difficult and tedious. Moreover, it leaves the patient with a urethra further damaged, the wound is in a bad place, and there is a chance of trouble with a urinary fistula and sometimes delay in healing. I have known several cases to do very well, and even with neglect after treatment on the patient's part to go very many years before they returned with acute retention of urine. Probably with reasonable care in passing a bougie the patient might have avoided further trouble. In many cases with false passages the difficulty of finding the tiny aperture of the stricture, together with the dirty position of the wound, and the sensitive area in which it is situated, condemns Wheelhouse's operation at the present day, although it was undoubtedly a good operation at the period when it was first performed. With modern experience in the treatment of suprapubic wounds, retrograde catheterization and dilatation of the stricture is preferable.

In such a case as I have described my method of late years has been, in the first place, to pass some sort of a catheter or bougie and perform rapid dilatation of the urethra. If this fails I select a time when the bladder is distended and make a suprapubic opening in the bladder; a No. 10 or 12 catheter (silver) is then taken in the right hand and easily passed into the bladder end of the urethra as far as the stricture. A No. 8 silver catheter is then passed into the penile urethra until it meets with the point of resistance of the stricture, avoiding the false passages if possible. The catheter in the bladder is then advanced with firm pressure, but without violence, until the stricture is stretched and pushed forwards as much as possible. With this catheter held firmly in position the No. 8 catheter is manipulated with the left hand and disentangled from any false passages; it is passed on carefully but firmly until metallic contact is made between the two catheters. Once certain of metallic contact some force and a little rubbing action may be used as long as the surgeon is certain the two catheters are touching at

their points. It is now easy to hold the points of the two catheters in contact, and to allow the penile catheter to push the bladder catheter gradually backwards until the former is in the bladder. A larger penile catheter is now passed in place of the No. 8. If the larger catheter gets trapped in the false passages it is very easy to slip in the bladder catheter again from the suprapubic wound and make contact with a penile catheter.

The urethra can now be rapidly dilated to No. 16 or 18, and a No. 12 silver or a large size hard rubber catheter tied in. The bladder is well washed out through the catheter and suprapubic wound and a drainage tube purse-stringed into the bladder wall. The wound is stitched up, or if too dirty the stitches are inserted and left untied for a few days. It is advisable to put a small drainage tube into the wound below the last stitch, if the wound is sutured at the time, in case of a leak by the side of the large tube. The suprapubic wound is treated as usual after a prostatectomy, and the catheter left in the urethra for a week. The bladder is washed out once or twice daily, according to the condition of the urine.

A case operated on recently by this method left the hospital in four weeks with the suprapubic wound healed, except a superficial granulation and a urethra that a No. 16 would drop through by its own weight. His recovery was delayed by a misunderstanding by which the catheter was removed in four days; the house-surgeon was unable to replace it. Under an anaesthetic a No. 18 sound passed quite easily, and I tied a fresh catheter in for a week. There was no further difficulty. If this had been done at first, as I directed, he would have been fit to go out some days or a week earlier.

I have been unable to find this operation described in any textbook on genito-urinary surgery. Thomson Walker mentions retrograde catheterization. He says: "Suprapubic cystotomy is performed, and retrograde catheterization with a metal sound. The point of this is cut down upon in the perineum. The operation has little to recommend it over the perineal dissection." This is only a method of doing Wheelhouse's operation. I have adopted it with advantage in a case in which I failed to find the aperture in the stricture after starting a Wheelhouse operation in the ordinary way. It certainly solved the difficulty. Should the operation I have described fail, it would be the quickest way of dealing with the difficulty. At present I have never found any necessity, as retrograde catheterization has invariably succeeded.

I think it is highly probable that other surgeons may be using this method of dealing with troublesome strictures, although I have failed to find any record. I am sure those who have not done so will find it a very easy and safe way of dealing with these cases, and the result very satisfactory to the patient. It is needless to say that the whole operation must be performed with strict surgical cleanliness.

In considering what damage is done to the urethra by retrograde catheterization, it is necessary to remember that the actual length of a stricture of the urethra may be considerable, perhaps from half an inch up to 1½ in. or more, but the part of the stricture that is really so small as to prevent the passage of urine or a fine bougie is short; in my opinion it rarely exceeds a quarter of an inch, and is often less. It is this portion that is nipped between the points of the two metal catheters. With a fixed point in the bladder end of the urethra, it is possible to force the penile catheter effectively through the constriction by steady pressure, or with a slight grinding movement. The exact size of the penile catheter may have to be varied, but the No. 6 to 8 is the usual size required to give the necessary rigidity. Once the catheters are in good metallic contact the whole difficulty is overcome.

The damage to the urethra is very slight, and the free drainage of the bladder tends to prevent any inflammatory reaction on the kidneys such as sometimes takes place after passing a catheter. The patient is far more comfortable afterwards, and is not so long in recovery on the average, in severe cases, as after Wheelhouse's operation. I can strongly recommend the operation in selected cases as easy, certain, and better for the patient.

A MONUMENT has been erected at Rome, Georgia, U.S.A., to the memory of Dr. Robert Battey, the originator of Battey's operation, oöphorectomy, first performed at Rome, U.S.A., in 1872. The chief address at the inauguration was made by Dr. Howard Kelly, of Baltimore.

SUGGESTED AUTOINOCULATION OF A RODENT ULCER.

BY

S. C. DYKE, M.B., D.P.H. OXON.,

PATHOLOGIST TO THE CLINICAL UNITS, ST. THOMAS'S HOSPITAL.

IN view of the interest attaching to the autoinoculation of malignant growths the following case may be worth recording:

F. L., a woman aged 71, was admitted to the wards of the Surgical Unit, St. Thomas's Hospital, under Sir Cuthbert Wallace, suffering from a large ulcer over the spine, in the sacro-iliac region. The ulcer, which on admission was about four inches in diameter, was preceded by a small itching papule about five years previously; it steadily increased in size and commenced to ulcerate about one year before the patient's admission to the hospital. As seen in the ward, the ulcer presented a hard, raised edge and was diagnosed clinically as an epithelioma.

The patient also showed a small ulcer on the left upper lip, clinically resembling a rodent ulcer. The history in regard to this was that the patient had been bitten at this spot by a dog about a year previous to admission. The wound healed to a certain extent, but then broke down, and had since remained as a small, slowly growing ulcer.

Both ulcers were excised by Mr. W. W. Wagstaffe, and on examination both proved to be rodent.

Up to a short time before admission the patient had been in the habit of herself dressing the ulcer on her back, and it is easy to understand how cells could have been carried from it on the patient's fingers to the fresh raw surface on her lip resulting from the bite. It is not suggested that there is any absolute proof that inoculation occurred in this way; cases of multiple rodent ulcer, where there is no question of autoinoculation, are common enough, and this may have been one of them. On the other hand, the coexistence of the original ulcerating growth and of a raw surface on an easily accessible place like the lip established a state of affairs very favourable to inoculation, and that such inoculation occurred may at least be regarded as highly probable.

The literature in regard to autoinoculation of malignant growths was very fully reviewed by Shattock and Dudgeon¹ in 1914. They record two cases, one reported by Butlin and one by Schimmelbusch, in which the evidence for autoinoculation by means of the fingers is so strong as to be almost conclusive. One of these cases was an epithelioma; the nature of the growth in Schimmelbusch's case is not mentioned. No instance of suggested autoinoculation of a rodent ulcer occurs among those collected in Shattock and Dudgeon's paper.

REFERENCE.

¹ *Proc. Roy. Soc. Med.*, viii, 1915 (Path.).

Memoranda:

MEDICAL, SURGICAL, OBSTETRICAL.

PERNICIOUS ANAEMIA: REPEATED DOSES OF CALOMEL: RECOVERY.

THREE years ago I attended a married lady, 37 years old, for anaemia. There was no haemorrhage to cause it. The complexion was lemon-coloured. The number of red corpuscles was about three-fifths of the normal, the colour index was above normal (1.25), and there was poikilocytosis. She got steadily worse in spite of arsenic and other tonics, until she was confined to bed. As she complained of the irritation caused by passing uric acid crystals, of which there was a considerable amount, the arsenic was stopped, and she was given 2-grain doses of calomel at first twice a week for six weeks, afterwards once a week for another six weeks, and finally once a month; she has kept on with the monthly dose until the present time.

The improvement after a few doses of calomel was marked. The uric acid crystals disappeared, and the anaemia steadily improved.

With the exception of some red bone marrow tabloids, after she had begun to improve, and some soda mixture for dyspepsia, she had no other drugs. At the present time she feels and looks quite well. Blood smears sent to the Clinical Research Association were reported on as follows:

"A differential count of the white blood corpuscles gives the following result:

Polymorphonuclear neutrophiles ...	32 per cent.
Small lymphocytes ...	62 "
Large lymphocytes ...	4 "
Eosinophiles ...	0.5 "
Mast cells ...	0.5 "
Myelocytes ...	1 "

"The red blood corpuscles seem to have a fairly high colour index. They vary considerably in size and very appreciably in shape.

"Megalocytes are very common. Microcytes and poikilocytes are also seen.

"Diffuse basophilia is seen fairly frequently, and nucleated forms are present in the proportion of one megaloblast per 100 leucocytes.

"No normoblasts were seen. The films gave an impression of a fairly well-marked leucopenia. These films are very suggestive of pernicious anaemia."

South Norwood.

JOHN C. FERRIER, M.D.

TARTAR EMETIC FOR VENEREAL GRANULOMA.

IN the *BRITISH MEDICAL JOURNAL* of November 30th, 1920, Dr. H. Lovett Cumming of Shanghai strongly advocates the use of intramuscular injections of tartar emetic in early cases of venereal granuloma. Might I venture a plea in favour of the intravenous route, both on account of simplicity and of the excellent immediate results both in early and late cases?

All my cases have been native Papuans. During the past eight months I have treated 84 cases (40 males and 44 females); in every instance the patients left the hospital apparently cured after a course of intravenous injections of tartar emetic. It has been impossible to trace the after-history of the majority, so that no statement can be made as to how permanent these results may be. However, four cases seen six months after finishing the treatment showed no sign of relapse. On the other hand, three cases definitely relapsed within two months of finishing the injections; these three cases received a second series of six injections. One of these cases four months after the second series shows no signs of relapse, and the smooth, healthy condition of the scars would lead one to believe that the cure is permanent.

Method.

A solution of 1 per cent. tartar emetic in distilled or rain water is filtered and boiled for two minutes. The injection is given on the same day with a 20 c.cm. Record syringe; 10 c.cm., containing 0.1 gram, is given twice weekly for ten injections; an interval of ten days is allowed to elapse, and then five more injections are given. In the case of men the dose can be increased up to 15 c.cm., containing 0.15 gram, without any very troublesome reactions, but 0.2 gram seems to be a dangerous dose to give as a routine. Acute antimonial poisoning developed in one case after such a dose.

The injections were given generally into the veins of the arm. Any extensive leakage into the subcutaneous tissues resulted in a most painful swelling with much oedema, which subsided in about two weeks without suppuration.

The beneficial effects of this treatment are apparent after two injections—that is, at the end of the first week. The rate at which new epithelium covers the raw ulcerated surfaces is remarkable. Islets of epithelium dotted here and there over the denuded area spring into existence. In the extensive cases of long standing new epithelium grows out from the anal margin and urethral orifice.

W. E. GIBLIN, M.C., M.B.

Samarai, Papua (British New Guinea).

THE PRIMARY ORGANISM IN CULTURES.

THE following may be of interest to some of your readers:

A short time ago I was asked to investigate a small epidemic of cases showing the following symptoms: (1) Pains in the limbs, (2) headache, (3) pyrexia, (4) slight sore throat. Cases in all stages, from the acute to the convalescent, were examined.

Stained smears from cultures of nasopharyngeal swabs of the early acute cases showed a pure culture of a Gram-negative coccus. Cultures of the rest showed a variety of organisms, among which was the Gram-negative coccus. On taking smears from the pure cultures two days later, I found that the Gram-negative coccus was dead and staining very faintly, and that what before appeared pure cultures

now showed a variety of organisms resembling smears of the convalescent cases.

Apparently, what had happened in the convalescent cases had now happened *in vitro*—namely, the primary organism had died, and when this happened the other organisms which had been present in the mucus of the swab began to grow. So that—and this is the point I wish to make—unless cases had been examined in the very early stages, one would have made the mistake of ascribing the epidemic to mixed infection.

I may add that my experience has led me to believe that this difficulty of getting the primary organism is responsible for a number of the failures of vaccine therapy.

C. B. DYSON.

Captain R.A.M.C., Officer in Charge,
District Laboratory.

Southlife.

Reports of Societies.

ORGANISM CULTIVATED FROM CARCINOMATA.

AT a meeting of the Edinburgh Obstetrical Society on June 8th, with Dr. WM. FORDYCE, President, in the chair, specimens of pathological and clinical interest were shown by the President, Drs. HAIG FERGUSON, H. S. DAVIDSON, G. R. LIVINGSTON, and ROBERTSON DOBIE.

Dr. JAMES YOUNG gave a preliminary communication on the life-cycle of an organism that he had obtained by cultivation from carcinomatous tumours. In culture the organism appeared ordinarily as oval or rounded bodies of different sizes and with a bipolar staining, and as bacillary forms of a length and thickness varying with the medium. The round forms were found to vary in size according to the stage in their development. All stages in their evolution were shown, and it was pointed out that in suitable media they proliferated actively. Under certain conditions they clumped together to form densely staining masses of a rounded or a lobulated character. Dr. Young said that he had succeeded in producing germination of these masses. In the process they at first became paler in areas, the remainder of the staining matter showing as masses of irregular size and shape. Eventually the whole spore mass became pale or finely granular, and minute rod-like structures were formed. These became free and developed into the bacillary forms, which Dr. Young believed were the vegetative phase of the organism. The filaments were long or short, and their thickness varied from very fine threads to comparatively thick elements. They usually stained deeply at each end, and they often had deeply staining granules along their course. Dr. Young believed that by cultivating pieces of carcinomatous tissue in a special medium, which he described, he had been able to recognize that the deeply staining masses, which are present commonly in the nucleus or in the intercellular spaces, are in reality spore masses. He had been able to watch them germinate into the rod-like or byphal forms. He had isolated the organism from 28 cases of human carcinoma, and he had also obtained a similar organism from breast carcinoma in the mouse. As controls he had used the medium without tissue and with non-carcinomatous normal or diseased tissue. He believed that the organism belonged to the fungi, but he had been unable so far to classify it. As far as he could say, he believed that the vegetative phase of the germ was passed in the nucleus.

THE fourth report of the Conjoint Board of Scientific Societies contains evidence that scientific investigation is being seriously hampered by the heavy cost of the publication of results. An exceptional number of papers are being communicated to the scientific societies, including many held up during the war, but the resources of the societies, which have not increased, are insufficient at present prices to publish even the normal pre-war number. The report contains an abstract of the third report of the Committee on the Water Power of the Empire, suggesting that a conference should be held with the various dominions and dependencies of the Empire with a view to the creation of an Imperial Water Power Board with powers to carry out a comprehensive policy for stimulating, co-ordinating, and where necessary assisting development throughout the Empire.

Reviews.

THE DAWN IN EUROPE.

BETWEEN the history of ancient Greece and Rome and the close of the glacial period lies the long series of centuries which marks the dawn for modern humanity in Europe. These centuries, numbering roughly one hundred, and known to the archaeologist as the Neolithic and Bronze ages, have been calling for a historian these years past, one who could weave into a consecutive whole the dry facts uncarved by generations of grave-searchers. The best historian we have discovered, the man who has succeeded in painting a vivid and living picture from the scanty material now available, is JOHN M. TYLER, Professor Emeritus of Biology, Amherst College, U.S.A. In his volume, *The New Stone Age in Northern Europe*,¹ he seeks to answer questions we are all interested in: Whence came the fair-haired Nordic peoples who live round the North and Baltic seas? How did they come by their Germanic or Saxon speech? How did they come by their robust manner of living? To be sure the answers he gives us are not final—are not even satisfying—but the manner in which he propounds his problems and frames his answers are those of a facile artist.

He is one of those writers who can have justice done to them only by quotation. The first excerpt we cite is chosen from the chapter in which he pictures the kind of life led by the lake-dwellers in central Europe some five or six thousand years ago:

"Could we have sat on one of these village platforms of a summer afternoon and looked out to the wheat fields on the shore, and seen the canoes come in with fish and game, and the cattle returning from the mainland pasture; could we have watched the men fashioning implements and all manner of woodwork, and the women grinding the grain or moulding the pottery, or spinning or weaving, we should have found a great deal to interest us. The fruit and berries, the smell of roasting fish and baking bread."

A clever picture which combines into a living whole the odds and ends gathered by generations of patient and learned archaeologists. Mr. Tyler's merits constitute even his defects, for to get his vivid results he has, time upon time, to convert probabilities into actualities.

Nevertheless, here is a writer who can waken the past and make it live with a verve. Another passage may be cited to show how he handles the "invention" of agriculture, the discovery which heralded the beginning of neolithic culture:

"When she turned homeward with her load of spoil, some berries, seeds, and small bulbs doubtless fell to the ground and escaped her notice. These grew and flourished in the richer soil around the hut or shelter, for all the garbage could not have accumulated in the hut. Some unusually observing woman noticed this and protected the plants, or even cultivated them a little with her digging stick . . . and gradually started a garden."

This passage is taken from p. 103, and when we come to p. 223 we find the author's gallant supposition has become a fact, for there we read:

"We have seen that women were the first great discoverers and inventors; discoverers and founders of all our household arts and crafts as well as of most of our science."

Our author has, as all good men should have, a "soft side" for women; but if we take as our guide to the past our experience of the present, then we fear it is difficult to allow the claims he here makes for the inventive faculty of early neolithic women.

In spite, however, of a too free use of his fancy and of his genius for painting homely pictures, he has written a book which is not only readable but deserves to be read, for it is founded on a very close and competent study of available literature. Indeed, the list of references to authorities given at the end of the book will prove useful to novice and expert alike. Above all, we wish he had broken away from the traditional story that the early history of man is that of a cradle-land in Asia from which wave upon wave of migrants have issued to give the world its present population. The true story will show many cradle-lands, and a world which was not always echoing the resounding tramp of migratory hordes.

A. KEITH.

¹ *The New Stone Age in Northern Europe*. By John M. Tyler. London: Bell and Sons, Ltd. 1921. (Demy 8vo, pp. 323; illustrated, 15s. net.)

THE NURSING OF EYE CASES.

THE nursing of ophthalmic patients is a special branch of the nurse's duties; in ELLIOT'S *The Care of Eye Cases*, she will find all that is necessary for her to know about the subject.² The book is divided into three parts: in the first are details on the anatomy of the eye, on aseptis and antisepsis in eye surgery, on drops and other remedial measures, bandages, shades and dressings, on the preparation for an eye operation and the care of the patient after operation. The second part deals with the more important diseases of the eye in a brief manner, but sufficiently for the purpose of the work; an appendix is devoted to instruments.

Every surgeon has his own ideas and his own technique, but we venture to think that few will cavil at the sound advice which is presented to the nurse on nearly every page of this book. Perhaps the author might with advantage have laid more stress on the necessity for a nurse who is looking after a case of blennorrhoea to wear a pair of protective goggles and rubber gloves for her own protection; and we should have welcomed a few paragraphs on the care of ophthalmic instruments. We note that the author considers that a Buller's shield is now little used; but we believe that many eye surgeons are old-fashioned enough to consider that a Buller's shield forms a most important part of the treatment of unilateral blennorrhoea and of diphtheria of the conjunctiva, both of them, it is true, conditions happily rare in this country.

The book is well brought out, the illustrations are numerous and very good, and the text remarkably free from typographical errors, though a few have crept into the appendix, such as Placido's disc, Liebrich's probes, the Moorfield's hook, while Streatfeild's name is misspelt. Junior ophthalmic surgeons, who have to deliver a short course of lectures to nurses on ophthalmic surgery, will find in this book an admirable foundation on which to build their lectures.

DISEASES OF CHILDREN.

The Diseases of Children,³ by the late Sir JAMES GOODHART, edited by Professor G. F. STILL, now appears in its eleventh edition, and so proclaims its still vigorous life. The book is well known, and its qualities are proved by the test of time. Its form and size remain the same, but the number of illustrations has increased to sixty. In its 900 pages it gives a sufficiently complete and an admirably practical account of the subject. Goodhart set out to write his book in 1885 from the standpoint of the clinician, and especially from that of his own clinical experience. Through successive editions, and since the accession of Dr. Still to joint authorship, these outstanding qualities have been retained. We find faithful and vivid clinical descriptions of disease and a constant appeal to clinical experience. It is not difficult to understand the success of a book conceived on this plan, and written by two men, each an acknowledged master of his subject in his own generation.

We have an impression that the student would find this an easier book to read if, in the accounts of the various diseases, a more prominent and systematic place were given to pathology, and if the accounts of symptoms in all their fullness and variety were more deliberately connected with the diseased processes underlying them. We would not have less said about symptoms; but it would assist the reader, especially the student reader, if pathology and morbid anatomy were given their paragraphs and subtitles as regularly as symptoms, diagnosis, and treatment. It is interesting to note Dr. Still's views on some matters of immediate interest and discussion. He is sympathetic but cautious towards the doctrine that rickets is due to the lack of a fat-soluble vitamin. He admits the therapeutic value of the newer arsenical preparations in the treatment of congenital syphilis, but on the whole prefers the older methods of treatment by mercury, which are simpler, less painful and dangerous, and probably, he thinks, as effective. He has not admitted the term *spasmodiphilia* into his account of tetany and laryngismus: the word is perhaps clumsy, but some term covering a variety

of clinical conditions that seem to belong to one group is useful. More might perhaps have been said about anaphylaxis, with reference to asthma and certain of the cases of urticaria and eczema in children.

We cordially welcome this new edition of a book that has now served the needs of students and practitioners of medicine for thirty-five years. Goodhart abhorred a compilation. He was not slow to acknowledge his debt to other writers and teachers, but in his book he aimed chiefly at communicating what he had learned and proved in his own wards and practice. Dr. Still carries on that good tradition, and so retains the great merit of the book, that it is written by those having authority, and not as the scribes.

THE CLACTON MILITARY HOSPITAL.

WHEN war broke out the Governors of the Middlesex Hospital offered their convalescent home at Clacton-on-Sea for the treatment of wounded and sick soldiers. The War Office accepted the offer, subject to the condition that a properly qualified medical officer could be found to reside in the hospital. The Board of Governors was faced with the difficulty that nearly all the hospital surgeons had been mobilized for various duties. There remained, however, the two gynaecologists, Dr. Comyns Berkeley and Dr. Victor Bonney, who, being over military age, accepted the post of resident medical officer to the hospital at Clacton between them. From August, 1914, to February, 1919, each of them took half-weekly turns of duty. Their work, surroundings, and experiences are recorded in *The Annals of the Middlesex Hospital at Clacton-on-Sea during the Great War*.⁴

The hospital was one of the "first-line" distributing hospitals in the Eastern Command, and during the four years and a half of its existence dealt with 9,242 patients suffering from all sorts of medical and surgical conditions, many of a serious nature. The solitary resident medical officer acted as physician, surgeon, specialist, x-ray expert, house-surgeon, house-physician, and registrar—just as if these two gynaecologists were officers in the R.A.M.C., ready to go anywhere and do anything, though neither, in fact, held a commission. The volume is not a record of scientific work; the description of the medical and surgical results is condensed into 14 of the 127 pages. The book is a chatty account of life in a soldier's hospital during the war at an exposed position on the East Coast. It is filled with many anecdotes of the medical officers, the matron, sisters and V.A.D.'s and other members of the staff, and of the patients; the hospital dog, donkey, and motor car are not forgotten. The illustrations are many, and consist of sketches, often comic in nature, by James Gibbon, Dr. T. Grimsdale, and Dr. Eric Fagan, and of photographs, some of which are somewhat spoiled by a curious speckling. At the end of the book is a complete list of the staff, the auxiliary hospitals to which patients were distributed, and the regiments to which patients belonged. There is also a list showing the extent to which the shower of honours connected with the war reached the Clacton Hospital; a list chiefly remarkable for its brevity. The Royal Red Cross reached the matron, the housekeeper, and a nurse. The strenuous labours, and sacrifice of time and money by the honorary surgeons appear to have passed quite unnoticed; there is no mention even of letters of thanks. No doubt the explanation is that Clacton, as one of the authors describes it, is really "off the map." It leads nowhere, and the only way out is the way you came in. The object in publishing the book is to advance the cause of the Middlesex Hospital by drawing attention to one part of its war services. There must be many to whom the story will appeal, and we wish the authors every success in their enterprise.

NOTES ON BOOKS.

THE second quarterly instalment of vol. lxxi of the *Guy's Hospital Reports*⁵ reflects credit on the energy of the editor, Dr. A. F. HURST, both for its punctuality and for the interest of its contents, which have not, as some-

² *The Care of Eye Cases*. A Manual for the Nurse, Practitioner and Student. By R. H. Elliot, M.D., Sc.D., F.R.C.S. London: Henry Frowde, and Hodder and Stoughton, 1921. (Demy 8vo, pp. 184; 51 figures. 12s. 6d. net.)

³ *The Diseases of Children*. By the late Sir James Frederic Goodhart, Bt. M.D., LL.D., Aberd., F.R.C.P. Edited by G. F. Still, M.A., M.D., F.R.C.P. Eleventh edition. London: J. and A. Churchill, 1921. (Demy 8vo, pp. 957; 60 figures. 32s. net.)

⁴ *The Annals of the Middlesex Hospital at Clacton-on-Sea during the Great War, 1914-1919*. London: W. J. Clark and Co. 1921. (Fcap. 4to, pp. 127. Illustrated.)

⁵ *Guy's Hospital Reports*, vol. lxxi (vol. i, Fourth Series), No. 2, April, 1921; pp. 137-251. Edited by A. F. Hurst, M.D. London: Henry Frowde, and Hodder and Stoughton, 1921. (12s. 6d. Subscription for volume of four numbers. £2 2s.)

times happens in hospital reports, been previously published. The first article is by Dr. Newton Pitt, *Le Moniteur* of the late Dr. P. H. Pye-Smith, who died in 1914; it quotes some of his numerous aphorisms, the last to the effect "Be sympathetic, and never give a minute diagnosis to the patient himself." Sir William Hale-White supplements his recent article on "Richard Bright and the discovery of the disease bearing his name" by another on his observations other than those on renal disease. The fourth of Dr. J. A. Ryle's studies in gastric secretion records experiments performed on himself to ascertain (1) the degree of discomfort entailed by swallowing and retaining the gastric tube, and (2) the secretory response to a standard test meal in a healthy subject; on no occasion was any real difficulty experienced in swallowing the tube, and after the first trial no unpleasant symptom of any kind was noted, talking and even mastication not being interfered with. Hour-glass contraction of the stomach is admirably described and illustrated in an article by the Editor and Mr. R. P. Rowlands. Mr. A. W. Ormond discusses the pathological effects of the visible and invisible spectrum on the eye, and points out the need for further information on the exact wave-lengths responsible for the morbid effects. Two cases of unilateral hysterical deafness cured by the monochord, an instrument consisting of a steel bar designed to produce high notes, are recorded by Mr. Mollison; and as Mr. T. B. Layton advocates local anaesthesia for the removal of tonsils in adults, and Mr. Zamora reports four cases of mastoiditis and complications without previous otorrhoea, the throat and ear department is well represented. Dr. G. W. Nicholson's studies on tumour formation show a philosophic outlook and much thought; and the volume closes with a case of impacted upper wisdom tooth recorded by Mr. Rowlands and Mr. M. F. Hopson.

The tenth edition of the *Elements of Practical Medicine* by the late Dr. A. H. CARTER, who died in 1918, appeared in 1912, and last year the eleventh was revised and brought out by Dr. A. G. GIBSON,⁶ Lecturer on Morbid Anatomy in the University of Oxford, and Physician to the Radcliffe Infirmary and County Hospital, Oxford. A happier choice of an editor it would have been difficult to find, for Dr. Gibson keeps an accurate watch on the pulse of current medical opinion and has performed his duties with a due sense of proportion. The war has considerably modified and added to our knowledge of some diseases, and care has been taken to incorporate as much of this as comes within the scope of this well known manual, which, as its title implies, is strictly elementary and more suited for the student when commencing clinical work than for the practitioner. In a short appreciation Dr. Carter is described as representing that type of English doctor of which Sydenham was the earliest example.

Professor O'DONOGHUE'S *Introduction to Zoology* for medical students supplies a definite want. The types selected are those which usually appear in the syllabus of elementary examinations in zoology, though the arrangement is somewhat different. The author has adopted Huxley's method of commencing with a vertebrate type, in this case the frog. He deals next with the protozoa, including the life-history of the malaria parasite, coelenterates, earthworm, dogfish, and rabbit. A chapter is devoted to histology and cytology, another to evolution, variation, and heredity, and two to embryology, the chick and the rabbit being selected as the examples in dealing with organogeny and later development. The book is clearly written and understandable. The illustrations are not too loaded with detail, so that they can be followed easily by the beginner. Physiology is dealt with more fully than is usual in a textbook of zoology, and there is a short account of such matters as toxins and antibodies generally. These are valuable additions for all students, more particularly students of medicine, for whom the book is primarily intended. It is a most useful textbook for the elementary student, and anyone who has mastered it has a good solid foundation on which to build.

Most medical men who were on active service during the war have an idea that if they cannot speak French fluently at least they can understand the language. When, however, the average man attempts to read a French medical work—and those who looked a few years ago to

Germany as the fount and origin of modern medical matters may well be surprised at the wealth of scientific information that French medicine has to offer—he is humbled by his ignorance of the precise meaning of many of the scientific terms. To his aid comes the *French-English Medical Dictionary* that Dr. ALFRED GORDON of Philadelphia, has edited. It is full, and appears, so far as we have tested it, to be accurate; it can be commended as a very useful little volume.

The *Empire Municipal Directory and Year Book*,⁷ which has now attained its thirty-ninth annual issue, is a useful directory of the British and Colonial municipal corporations and county, urban, and rural councils. It includes lists of the chief officials, with their addresses and telephone numbers. There are also special articles on such subjects as public health, public cleansing and waste utilization, housing and town planning, practical sanitation, and sewage disposal, containing reviews of recent progress on these problems and descriptions of all the approved methods. The volume may be commended to the attention particularly of public health officials.

⁶ *French-English Medical Dictionary*. By A. Gordon, A.M., M.D. London: H. K. Lewis and Co., Ltd. 1921. (Roy 8vo, pp. 165, 16s. net.)
⁷ *The Empire Municipal Directory of Local Authorities and Officials and Year Book of Municipal Engineering and the Sanitary Record* for 1921-22. London: The Sanitary Publishing Co. Ltd. 1921. (7 x 9½, pp. 271, 10s. 6d. net.)

APPLIANCES AND PREPARATIONS.

A Compact Warm Ether Inhaler.

DR. G. A. TICEHURST (Assistant Physician, East Sussex Hospital, Hastings) writes: The advantages of warm ether vapour for anaesthesia by the open method are generally admitted; they were described by Shipway in this country in 1916,¹ and considerable experience was afforded later by the use of his apparatus at many of our clearing stations and hospitals during the war. I have, however, felt the need of an inhaler of some kind which, being independent of an extraneous source of heat, and not needing continuous air pumping, would be sufficiently compact to be easily accommodated in the anaesthetist's bag, and would yet warm the inhaled vapour to a sufficient extent. A fairly obvious device is the utilization of the heat otherwise lost to the patient in his expired breath; this takes place in all closed forms of inhaler, and to a certain degree with open methods, using a mask. It is incidentally exactly comparable to the exhaust heating of a motor-car carburetter. The inhaler in which I have employed this device somewhat resembles the small Roth-Deaeger instrument, and consists (see illustration) of three parts: 1 a face-piece carrying the usual rubber cushion and provided with inspiratory and expiratory valves; 2 a radiating chamber containing nineteen thin metal tubes; and 3 a container for sponge or gauze upon which the ether is dropped. Ether is inspired from the container through the warmed "radiator" tubes, while the expired breath is directed by the expira-

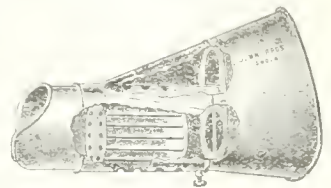

tory valve through a short passage into the radiating chamber, where it passes between the tubes, to which it gives some of its heat, and escapes through holes in the opposite side. The radiator is locked to the face-piece by a small screw, and the container can be revolved into any convenient position for the dropping of ether. The inhaler is strictly of the semi-open type, but the airway has been kept everywhere as free as possible to prevent restriction of breathing and promote interchange of heat; a slight amount of rebreathing is allowed by the volume of the face-piece, the in- and out-going streams being otherwise separate. Without the radiating chamber in use the temperature of the inspired vapour above the face-piece is from 32 to 33 F. This is considerably lower than is shown by a thermometer under a Skinner's mask during "open" administration; but here the actual temperature is variable and uncertain owing to the fluctuation of the alternate warm and cold streams. On bringing the radiating chamber into use the temperature rises in the course of a few minutes to 65-70 F., occasionally higher, generally rather above room temperature, and remains fairly steady. This is again not so high as can be obtained with an extraneous source of heat, but is, I think, sufficient for the purpose. There is a considerable economy of ether over the use of a mask, and a welcome diminution in the amount of ether in the air surrounding operator and anaesthetist. Anaesthetic mixtures can be used equally well if desired. The instrument is made entirely of metal except for the rubber cushion and the valve-flaps; it can therefore be readily sterilized. Its length is approximately 7 in. and its weight 13 oz. It has been made for me by Messrs. Down Brothers, St. Thomas's Street, S.E.1. I have not been able to find any description of an inhaler on these lines; if such exists I must apologize to the designer for my unconscious plagiarism.

¹ *Lancet*, January 8th, 1916.

⁶ *Elements of Practical Medicine*. By Alfred H. Carter, M.D. M.Sc., F.R.C.P. Revised by Alexander G. Gibson, M.A., D.M.Oxon., F.R.C.P. Eleventh edition. London: H. K. Lewis and Co., Ltd. 1920. (Cr. 8vo, pp. 695 + xx, 16s. net.)

⁷ *An Introduction to Zoology*. For Medical Students. By C. H. O'Donoghue, D.Sc., F.Z.S., Professor of Zoology, University of Manitoba. London: G. Bell and Sons, Ltd. 1920. (Demy 8vo, pp. 511; 173 figures, 16s. net.)

X-RAY AND RADIUM PROTECTION.

PRELIMINARY REPORT OF COMMITTEE.

THE X-Ray and Radium Protection Committee, representing the various radiological and other scientific bodies with their headquarters in the metropolis, after deliberating for some weeks, has issued its preliminary report, which is admittedly tentative in some of its recommendations. This report, which is a carefully thought out statement of present knowledge in regard to equipment, ventilation, and working conditions of *x*-ray and radium departments, was a matter of considerable urgency owing to the constant demand for guidance from individuals and institutions; it is printed in full below. After the completion of this, the preliminary part of its work, the Committee intends to proceed with its more extensive objects which may entail considerable research.

The chairman of the Committee is Sir Humphry Rolleston, K.C.B. The other members are: Sir Archibald Reid, K.B.E., C.M.G. (St. Thomas's Hospital), Dr. Robert Knox (King's College Hospital), Dr. G. Harrison Orton (St. Mary's Hospital), Dr. S. Gilbert Scott (London Hospital), Dr. J. C. Mottram (Pathologist, Radium Institute), Dr. G. W. C. Kaye, O.B.E. (National Physical Laboratory), and Mr. Cuthbert Andrews. The honorary secretaries are Dr. Stanley Melville (St. George's Hospital) and Professor S. Russ (the Middlesex Hospital).

Suggestions and offers of personal or other assistance are invited, and should be sent to the Honorary Secretaries of the Committee, care of Royal Society of Medicine, 1, Wimpole Street, W.1. Copies of the preliminary report may be had on application to the Honorary Secretaries.

Introduction.

The danger of over-exposure to *x* rays and radium can be avoided by the provision of efficient protection and suitable working conditions. The known effects on the operator to be guarded against are: (1) Visible injuries to the superficial tissues which may result in permanent damage. (2) Derangements of internal organs and changes in the blood. These are especially important, as their early manifestation is often unrecognized.

General Recommendations.

It is the duty of those in charge of *x*-ray and radium departments to ensure efficient protection and suitable working conditions for the personnel.

The following precautions are recommended:

1. Not more than seven working hours a day.
2. Sundays and two half-days off duty each week, to be spent as much as possible out of doors.
3. An annual holiday of one month, or two separate fortnights.

Sisters and nurses, employed as whole-time workers in *x*-ray and radium departments, should not be called upon for any other hospital service.

Protective Measures.

It cannot be insisted upon too strongly that a primary precaution in all *x*-ray work is to surround the *x*-ray bulb itself as completely as possible with adequate protective material, except for an aperture as small as possible for the work in hand.

The protective measures recommended are dealt with under the following sections:

- I. X rays for diagnostic purposes.
- II. X rays for superficial therapy.
- III. X rays for deep therapy.
- IV. X rays for industrial and research purposes.
- V. Electrical precautions in *x*-ray departments.
- VI. Ventilation of *x*-ray departments.
- VII. Radium therapy.

It must be clearly understood that the protective measures recommended for these various purposes are not necessarily interchangeable; for instance, to use for deep therapy the measures intended for superficial therapy would probably subject the worker to serious injury.

I.—X RAYS FOR DIAGNOSTIC PURPOSES.

(1) *Screen Examinations.*

(a) The *x*-ray bulb to be enclosed as completely as possible with protective material equivalent to not less than 2 mm. of lead. The material of the diaphragm to be equivalent to not less than 2 mm. of lead.

(b) The fluorescent screen to be fitted with lead-glass equivalent to not less than 1 mm. of lead, and to be large enough to cover the area irradiated when the diaphragm is opened to its widest. (Practical difficulties militate at present against the recommendation of a greater degree of protection.)

(c) A travelling protective screen, of material equivalent to not less than 2 mm. of lead, should be employed between the operator and the *x*-ray box.

(d) Protective gloves to be of lead-rubber (or the like) equivalent to not less than $\frac{1}{2}$ mm. of lead and to be lined with leather or other suitable material. (As practical difficulties militate at present against the recommendation of a greater degree of protection, all manipulations during screen examination should be reduced to a minimum.)

(e) A minimum output of radiation should be used with the bulb as far from the screen as is consistent with the efficiency of the work in hand. Screen work to be as expeditious as possible.

(2) *Radiographic Examinations ("Overhead" Equipment).*

(a) The *x*-ray bulb to be enclosed as completely as possible with protective material equivalent to not less than 2 mm. of lead.

(b) The operator to stand behind a protective screen of material equivalent to not less than 2 mm. of lead.

II.—X RAYS FOR SUPERFICIAL THERAPY.

It is difficult to define the line of demarcation between superficial and deep therapy. For this reason it is recommended that, in the reorganization of existing, or the equipment of new, *x*-ray departments small cubicles should not be adopted, but that the precautionary measures suggested for deep therapy should be followed. The definition of superficial therapy is considered to cover sets of apparatus giving a maximum of 100,000 volts (15 cm. spark-gap between points; 5 cm. spark-gap between spheres of diameter 5 cm.).

Cubicle System.

Where the cubicle system is already in existence it is recommended that:

1. The cubicle should be well lighted and ventilated, preferably provided with an exhaust electric fan in an outside wall or ventilation shaft. The controls of the *x*-ray apparatus to be outside the cubicle.

2. The walls of the cubicle to be of material equivalent to not less than 2 mm. of lead. Windows to be of lead-glass of equivalent thickness.

3. The *x*-ray bulb to be enclosed as completely as possible with protective material equivalent to not less than 2 mm. of lead.

III.—X RAYS FOR DEEP THERAPY.

This section refers to sets of apparatus giving voltages above 100,000.

1. Small cubicles are not recommended.

2. A large, lofty, well ventilated and lighted room to be provided.

3. The *x*-ray bulb to be enclosed as completely as possible with protective material equivalent to not less than 3 mm. of lead.

4. A separate enclosure to be provided for the operator, situated as far as possible from the *x*-ray bulb. All controls to be within this enclosure, the walls and windows of which to be of material equivalent to not less than 3 mm. of lead.

IV.—X RAYS FOR INDUSTRIAL AND RESEARCH PURPOSES.

The preceding recommendations for voltages above and below 100,000 will probably apply to the majority of conditions under which *x* rays are used for industrial and research purposes.

V.—ELECTRICAL PRECAUTIONS IN X-RAY DEPARTMENTS.

The following recommendations are made:

1. Wooden, cork, or rubber floors should be provided; existing concrete floors should be covered with one of the above materials.

2. Stout metal tubes or rods should, wherever possible, be used instead of wires for conductors. Thickly insulated wire is preferable to bare wire. Slack or looped wires are to be avoided.

3. All metal parts of the apparatus and room to be efficiently earthed.

4. All main and supply switches should be very distinctly indicated. Wherever possible double-pole switches should be used in preference to single-pole. Fuses no heavier than necessary for the purpose in hand should be used. Unemployed leads to the high-tension generator should not be permitted.

VI.—VENTILATION OF X-RAY DEPARTMENTS.

1. It is strongly recommended that the x-ray department should not be below the ground level.

2. The importance of adequate ventilation in both operating and dark rooms is supreme. Artificial ventilation is recommended in most cases. With very high potentials coronal discharges are difficult to avoid, and these produce ozone and nitrous fumes, both of which are prejudicial to the operator. Dark rooms should be capable of being readily opened up to sunshine and fresh air when not in use. The walls and ceilings of dark rooms are best painted some more cheerful hue than black.

VII.—RADIUM THERAPY.

The following protective measures are recommended for the handling of quantities of radium up to one gram:

1. In order to avoid injury to the fingers the radium, whether in the form of applicators of radium salt or of emanation tubes, should always be manipulated with forceps or similar instruments, and it should be carried from place to place in long-handled boxes lined on all sides with 1 cm. of lead.

2. In order to avoid the penetrating rays of radium all manipulations should be carried out as rapidly as possible, and the operator should not remain in the vicinity of radium for longer than is necessary. The radium, when not in use, should be stored in an enclosure, the wall thickness of which should be equivalent to not less than 8 cm. of lead.

3. In the handling of emanation all manipulations should, as far as possible, be carried out during its relatively inactive state. In manipulations where emanation is likely to come into direct contact with the fingers thin rubber gloves should be worn. The escape of emanation should be very carefully guarded against, and the room in which it is prepared should be provided with an exhaust electric fan.

Existing Facilities for Ensuring Safety of Operators.

The governing bodies of many institutions where radiological work is carried on may wish to have further guarantees of the general safety of the conditions under which their personnel work.

1. Although the Committee believe that an adequate degree of safety would result if the recommendations now put forward were acted upon, they would point out that this is entirely dependent upon the loyal co-operation of the personnel in following the precautionary measures outlined for their benefit.

2. The Committee would also point out that the National Physical Laboratory, Teddington, is prepared to carry out exact measurements upon x-ray protective materials and to arrange for periodic inspection of existing installations on the lines of the present recommendations.

3. Further, in view of the varying susceptibilities of workers to radiation, the Committee recommend that wherever possible, periodic tests—for example, every three months—be made upon the blood of the personnel, so that any changes which occur may be recognized at an early stage. In the present state of our knowledge it is difficult to decide when small variations from the normal blood count become significant.

NURSING associations in the United States of America have collected a sum of money to erect a memorial to the 284 American nurses who gave their lives in the war. It takes the form of a new building for the Florence Nightingale Training School for Nurses at Bordeaux, founded twenty years ago by Dr. Anna Hamilton.

THE third international post-graduate course in balneology and balneotherapy will be held at Carlsbad from September 11th to September 17th, when lectures will be delivered by members of the medical faculties of Berlin, Breslau, Budapesth, Erlangen, Göttingen, Halle, Prague, Rome, San Pablo (Brazil), Stockholm, and Vienna. The opening address will be given by Dr. Abderhalden of Halle.

THE PRIVATE CLINIC SYSTEM.

DISCUSSION AT THE ROYAL SOCIETY OF MEDICINE.

A GENERAL meeting of the Fellows of the Royal Society of Medicine was held on June 16th, under the presidency of Sir JOHN BLAND-SUTTON, to discuss the question of the private clinic system in Great Britain.

Sir THOMAS HORDER, who used the American term "group medicine," said that there was nothing new in this conception. The principle was in daily operation in most of the general hospitals, where patients were often transferred from one ward or department to another so as to secure for them the benefits of the service most nearly adapted to the nature of their disease. The facilities for group practice afforded by general hospital conditions had led to increased efficiency so far as the patient was concerned, and had also contributed to the advance of medical knowledge. It seemed natural, therefore, to consider some adaptation of the method to private practice; perhaps such a development was already overdue, and if the profession did not itself arrange for group medicine its hand might be forced by the public, and that would bring about many professional complications. The problem of the nursing home was bound up with this question of group diagnosis and treatment. The patient of moderate means wondered why little or nothing had been done to improve the present conditions in this respect, and if the development of group clinics hastened the arrival of institutions properly equipped and administered to replace the small private houses used as nursing homes, group medicine would at least have done something which would go far in its justification. Any clinic system must be planned so as to supplement the ordinary routine examination of the patient by facilities for expert investigation, and must also offer like facilities for more thorough and therefore more beneficent treatment than could be undertaken by any individual practitioner. It should also save time both for doctor and patient without sacrifice of efficiency. A practitioner working with a number of juniors, who were in effect his assistants and had no special knowledge or training, was a group indeed, but one which did not fulfil the requirements, and the same was true of a group consisting of a number of practitioners or consultants working together but not chosen so as to represent the various branches of medicine. A true group which did fulfil the requirements laid down consisted of a number of practitioners or consultants of equal professional status, chosen carefully—"hand-picked," as the Americans said—so as to be representative of various branches of medicine. Another system which fulfilled the requirements, although it was not a true group, was one in which a practitioner of great experience and balanced judgement first himself made a careful routine examination of the patients, and then referred them to particular specialists who were in association with him for expert investigation and report. The first of these units he called a group clinic, and the second a personal clinic. The group clinic had certain advantages: it could deal with patients having a large variety of diseases, and it would naturally have some arrangement by which its constituent members would be readily available for the expert examination of any patient. The chief of the personal clinic, on the other hand, must make his own special arrangements with his experts. In the group clinic meetings of all the members could take place at a settled time, whereas the chief of the personal clinic would rarely if ever meet all his experts together. Nevertheless, the personal clinic had advantages of its own. Its chief was brought into close touch with each patient, whereas in a group this personal relationship would tend to lapse, at least in respect to those patients whose trouble was found to concern more than one member of the group. The success of any form of group medicine depended upon a sound judgement at the outset in deciding what expert examinations were necessary, upon the subsequent co-ordination or integration of the various expert reports, and upon the decision as to a programme of treatment; and Sir Thomas Horder rather thought that in these respects the personal clinic would score. To send a patient round to a number of experts quite indiscriminately would bring the whole position of group medicine into disrepute. With regard to finance also, much greater difficulties faced the group clinic than the personal clinic. It was difficult to see how, under the group system, a flat-rate fee could

be arrived at without considering the members of the group as partners in a concern. On the other hand, the specialists attached to a personal clinic might be paid their customary consultation fees as extras. As a general financial principle, he thought it would be better to charge a smaller rate for the original survey, and then a surcharge for whatever special services were necessary, rather than to institute a larger flat-rate fee to cover all services. He left the problem of distribution among the members of the group to other speakers, and also the question of legal relationship, whether a deed of partnership or the setting up of an incorporated body was preferable. Certain precautions must be taken to prevent the growth of undesirable cliques, which would impair the cordial relationships existing at present among members of the profession. He feared also that the personal relationship between doctor and patient would tend to lapse in group medicine; it might be maintained by making the group no larger than was absolutely necessary to cover the main branches of practice, and by each member guarding the personal relationship of all patients who came originally to him. Up to now the private clinic supervised by one man who was fitted for this kind of work had been more easy to set going than the group clinic, yet it seemed highly probable that the group clinic would become a British institution. He believed that it had a better future than the personal clinic, although, of course, initial experiments must be regarded critically and its limitations must be faced—as, for instance, that it was less fitted for rural than for urban areas, and that some men were temperamentally less able than others to work in a team.

Sir HUMPHRY ROLLESTON said that the expression "team work" first became familiar in connexion with research into problems necessitating collaboration between experts in various branches of medicine. There its advantages were obvious, and its application to practice followed naturally. The question was how to place within the reach of the rest of the population the advantages which the necessitous poor got in the ordinary hospitals. To a certain extent practitioners in partnership had endeavoured to carry out the team idea. In choosing a junior partner, for instance, they would apply to the schools for one familiar with recent advances in surgery, and the older partners would give up their holiday for post-graduate instruction along some special line, so as to be authorities on a particular subject in their locality. He went on to refer to the great development of the Mayo Clinic at Rochester, Minnesota, and said that those who had had the opportunity of seeing the phenomenal success which had followed the organization of the Mayo brothers felt like the Queen of Sheba after her visit to Solomon. The Mayo Clinic had now become an educational and research institution as well, but originally it was an excellent example of a surgical clinic—the cases were mainly surgical—run on these group lines of medicine. There was room for a great deal of variation in the personnel and arrangements of team work; the team and its equipment might be made comprehensive, or it might be confined to a surgical or specialist function. The patients might be merely those belonging to members of the particular group, who had united their former practices so as to economize time and secure more satisfactory results, or they might be patients sent by outside practitioners for the purpose of diagnosis, to be returned with the report. In large cities there would be room for both these arrangements. In a small town the team might act injuriously to the interests of practitioners who were not members, and this must be prevented as far as possible. But in any case a team in an organized form was bound to come, if it had not already arrived. From the patient's point of view there was no doubt that a systematic examination by all available methods of the laboratory would be a great advantage. The procedure would be economical because the equipment would be concentrated in one establishment, so that the inclusive charge to the patient might be lower than would be the aggregate of fees under ordinary circumstances, while yet the return to the members might be higher. Medical men, with this combination of facilities and accessibility of advice, would get through their work in a more satisfactory manner and with less waste of time. A team of consultants and experts would be in the same position as a firm of general practitioners; as members of a team they might be regarded as a company, but he saw

no difficulty in securing any necessary statutory amendments to meet the position.

Dr. DRURY PENNINGTON spoke as a general practitioner who had had country experience. His attempts to get team work started had met with individual encouragement, but collectively there was a certain shyness among medical bodies, which hesitated to pronounce one way or the other. The most articulate objection was that the time was not ripe; but certainly the time was judged to be ripe for combination in all lines of trade and commerce. Was the medical profession alone to continue in the old-fashioned way? He maintained that the time was ripe, and for two reasons: (1) the rapidly decreasing power of the public to pay the old dues; (2) the formidable increase in the cost of diagnosis alone during the last fifteen years. When confronted with a chronic case having a multiplicity of symptoms probably arising from some fundamental cause or causes, he had found it necessary, in order to assure himself of the accuracy of his diagnosis, to apply to the bacteriologist and other experts for some of the links in the chain of evidence, but he had always to consider the patient's pocket, and this difficulty was often only surmounted by begging for gratuitous service from his colleagues—to which he greatly objected—or by converting his own fee into payment for such service. No one more highly appreciated the value of the advice of specialists than he did, but he thought that specialism sooner or later tended to produce a mental myopia, and the whole was sometimes lost in the part. He found himself often forced into being an arbiter between the conflicting opinions of rival specialists. He conceived it his duty to keep his eye on the individuality of his patient. He found himself less and less consulting with the man whose sole armamentarium was a stethoscope. Before many years were out he believed the general consulting physician would cease to exist, but he would find his regeneration in the rôle of assessor to a team. Dr. Pennington held that the time was ripe for an adaptation of medical practice to the evident requirements of modern science and economics alike. The formation of teams all over the country, each suited to the local requirements, must supersede the present system of individualism, and the faults which existed here and there in private practice would tend to disappear when the individual himself was no longer the only one to be considered.

Mr. BISHOP HARMAN said that he felt honoured in being asked to contribute to the discussion as Chairman of the Hospitals Committee of the British Medical Association, but he wished to make it clear that he had no authoritative information to give. There were certain points, however, which might throw light on professional feeling in the matter of these private clinics. During the war the Central Medical War Committee urged private practitioners to combine in order to foster subdivision of their work, thereby promoting economy and higher attainment in special branches, and to facilitate continuity during illness, holidays, and periods of study. The recommendation was well received and was acted upon with success. A combination for in-patient work in a private hospital in the provinces had been under review, and no exception had been taken to it. In general, he thought, the principle of combination, either for domiciliary treatment or clinic work, would be conceded. It was the necessary outcome of the growing complexity of medical work. It was the logical corollary of the established principle of hospital practice. It was a means of extending the known benefits, which patients in a charity foundation obtained as a matter of course, to private patients who were able to pay their way. In practice certain difficulties might arise: (1) The cost of establishing an efficient private clinic might be so high as to prevent a combination of capable doctors establishing their clinic on their own resources, and they might be tempted to accept lay association in finance, which might mean lay control or direction. The lay element would desire financial success, and the temptation to some form of advertising would be difficult to combat. Difficulties akin to this had arisen in connexion with establishments which were originally founded as quasi-medical institutions and now combined medical work with facilities for legitimate entertainment. A risk like this could be guarded against by a legal deed of constitution for each clinic before it was set up. (2) If powerful combinations became numerous they might exert an inhibitory influence on the younger members of the

profession who could not or would not seek admission to existing combinations. Possibly existing combinations might be powerful enough to prevent the establishment of new combinations, and thereby act detrimentally on the development of professional knowledge and skill. Possibilities such as these foreshadowed a risk of professional competition far more serious than anything now existing between individual practitioners or partnerships, and it was difficult to see how it could be guarded against. (3) Some might think there was a risk that the commercial aspect of a costly clinic would cause patients to be exploited for profit. That risk was present in any form of practice, individual or combined, and there was no safeguard against it other than a high standard of integrity in the profession. As long as the standard remained as high as it was to-day the risk was minimal, and there was no reason why it should not be maintained. In conclusion, Mr. Harman cited some actual expressions of intelligent patients in describing their experiences to him, which showed with what favour they viewed these arrangements.

Mr. W. H. CLAYTON-GREENE, speaking as a surgeon, declared that the existing system was most unsatisfactory to him. He believed that the phrase of a previous speaker, "mental myopia," excellently described the condition of some of the workers in laboratories who were not brought into contact with cases clinically. Specialism did narrow the view. At one end of Harley Street he thought there was a tendency to talk of ileum stasis, and at the other end a tendency to note duodenal irritation! If cases were consulted over, not only by the surgeon and physician, but by the radiographer and pathologist, many avoidable mistakes would not be made. The custom of sending a patient—or, rather, a piece of the patient—without any clinical report to the expert was utterly wrong. It resulted in what might be called the suggestion-error in diagnosis. These difficulties would be overcome if a clinical system were initiated whereby the specialists in different departments met and consulted and realized their own mistakes. On the operative side every one would agree that the smoothest operations were done in hospital, where real team work was available. How different was the condition obtaining in many of the nursing homes! It had to be remembered that no operation could be prophesied as a perfectly simple one. These reasons made him support most strongly the provision of private clinics. If a clinic system were introduced and did its job well, he had not the slightest doubt that the public would wear a path to its door.

Mr. W. S. DICKIE discussed in considerable detail the cost of setting up an institution for receiving private patients. In his view the ideal hospital for private patients might be constructed at a capital cost of not more than £500 a bed, and probably less. He discussed also the running costs, and his figures as he worked them out showed that a good private hospital might be run at seven guineas per bed per week.

Dr. A. F. HURST described the private clinic which he has set up twenty miles from London. In his view there was no question but that the patient needing elaborate examination gained considerably by the establishment of such a clinic. An inclusive fee made it possible to carry out many examinations, routine and otherwise, which they would be loath to make if each separate examination entailed an additional cost to the patient, and it had been remarkable what unexpected diagnoses they had reached as a result of these extra examinations. A clinic of this sort should be regarded as a place where there was a prolonged consultation. The saving of time to the medical man was very considerable because the work was all in one building, and there was no necessity to fit in various appointments at different places. Time was also saved from the patient's point of view, because within a week, even in the most complicated case, a definite diagnosis should be made if such diagnosis was possible at all. The presence of a resident medical officer was of enormous advantage because he took over a great deal of the routine work, and also was available to examine the patient and check the patient's description of his symptoms at any time, day or night. Dr. Hurst quite realized that the primary object of such an institution was diagnostic, but there were certain patients who ought to have their treatment under the same absolute control from day to day.

Dr. G. C. ANDERSON, who said that he spoke privately and not as an official of the British Medical Association, was quite sure that any movement on the lines of the private clinic system would be welcomed by the general practitioner. He urged the advantage it would be to a general practitioner to send a patient to a private clinic and there obtain a comprehensive report, with, most probably, an accurate diagnosis, owing to the ancillary aids to examination, combined with the ordinary clinical methods. Without such assistance the general practitioner might in the first instance direct the patient to a surgeon only to be told that the case was purely a medical one, or, again, that the surgeon must consult the radiographer. The fees charged at a clinic could be more moderate than the present fees charged by individual consultants because by combination the expenses would be lessened. Dr. Anderson sketched the possible constitution and working of a team. Each member might carry on his usual private practice at the clinic, where he would always have at hand a second opinion. Each member of the team might draw his own fees from the patients who consulted him at the clinic in a private capacity, but if any patient were sent by an outside practitioner to the clinic for general diagnosis the fee received for such diagnosis should go into the central pool, upon which would fall the burden of the upkeep of the establishment. The expenses necessary for the conduct of the clinic would be met out of this central fund, and the practitioners would thereby be enabled to carry on their private practice without any expense at all. Any surplus from the pool could be divided yearly among the members of the clinic. As for treatment, if a patient were treated in a nursing home attached to the clinic payment should be made in the usual way, the nursing home charges going towards the upkeep of the home, whilst the surgeon's or physician's fees would be paid direct to the individual who had undertaken the treatment. It would be an advantage to have a medical assessor attached to the clinic, to whom all patients other than those who wished to see a particular member of the team might be directed in the first instance. To be a success a private clinic should be conducted on such lines as would secure the hearty co-operation both of the general practitioner and of the consulting branch of the profession; the fact that such clinics existed should be communicated to the profession only in the usual way. Once the public was asked to aid in the financing of a nursing home the question of advertising was bound to arise, and he felt strongly that the control of private clinics, whether for diagnosis or treatment purposes, should be entirely in the hands of medical men.

Sir THOMAS HORDER then proposed a resolution:

That in the opinion of this meeting the time is ripe for the formation of group clinics in this country, and that sympathetic encouragement should be given to them by the profession and by its governing bodies.

Dr. C. O. HAWTHORNE suggested that it was inadvisable that such a resolution should be put to the meeting before the subject had been thrown open for general discussion; all the speakers had been those previously advertised to take part. He suggested that the discussion be adjourned to a convenient date.

Sir THOMAS HORDER fell in with this view, and it was agreed to hold a further meeting for fuller discussion, after which the resolution would be submitted.

THE USE AND ABUSE OF SCIENTIFIC MEDICAL LITERATURE.

A LECTURE which had its humorous touches was delivered at the Institute of Pathology and Research at St. Mary's Hospital on June 16th by Professor W. Bulloch, M.D., F.R.S., whose subject was the use and abuse of scientific medical literature. Professor Bulloch did not spare the frailties either of editors or contributors, and he appeared to think that medical journals still left a great deal to be wished for. His subject was suggested to him by a conversation he had with a house surgeon, who was proposing to write a paper on injuries of the upper extremity. Professor Bulloch remarked that this was an unusually comprehensive theme, and that if he confined himself to the last phalanx of the little finger he would probably

find sufficient material, but he discovered that the young man was almost childishly ignorant of medical literature, and had scarcely thought of referring to what might have been written before him.

Professor Bulloch began with a historical sketch, in which he touched slightly on ancient learning, the barrenness and decay of the centuries between the fifth and the eleventh, and the revival in Italy, gradually spreading from Salerno over Europe, until now there were in all the world 275 recognized universities, the largest in Paris, and the smallest at Reykjavik in Iceland with forty-five students. In the evolution of medical knowledge the era of dogma came first, with Hippocrates and Galen as its landmarks; then the era of empiricism, when medicine was based to a certain extent on experience, but was still dominated by preconceived notions, and was not capable of distinguishing between apparently similar phenomena; to this era belonged such terms as "rheumatism," "biliousness," and "congestion." Finally the concept arose that medicine was merely a branch of biology, and an age of specialism came in. Specialism had its bad side as well as its good, but it was mainly through specialism that modern knowledge had advanced. Books at first sufficed to keep pace with the growth of knowledge, but by degrees, with the rush of life, there arose a medical periodical literature. The first medical publications of this kind dated from the later years of the seventeenth century, and the growth had continued, slowly at first, but gathering momentum, until now there were between four and five thousand medical periodical publications of all sorts, including well over a thousand in the United States, over a hundred in Japan, and in China, with its splendid contempt for western civilization, only two, both of them in English. Some of the medical journals, particularly the American, were evanescent; but in our own more stable and conservative country the medical periodical literature shared these qualities, and was also immensely stodgy; the *Lancet* of to-day did not differ in substance and arrangement from the same journal of sixty years ago.

Professor Bulloch then gave some figures to prove how enormous was the output of the medical pen. Between 1893 and 1913, according to the *Catalogue of the Surgeon-General's Library* at Washington—the greatest medical library in the world—25,000 articles were written on tuberculosis alone, more than half of them dealing with the pulmonary form of the disease. At present there were 31 journals devoted exclusively to the subject of tuberculosis, 26 of them European and 5 American. Down to 1893 about 7,000 articles and books had been written on syphilis, but between 1893 and 1913 this output was doubled. In the same twenty years 7,000 articles were written on heart disease and 7,000 on pregnancy, including 870 on tubal pregnancy alone. What would be the result if this colossal production continued in the same ratio? At a time not very remote our libraries would have to be great cities, and all persons not engaged in writing would have to be engaged in editing or cataloguing. One of the good things which the war had done—perhaps its only virtue—was to bring about an increase in the cost of printing and paper, involving the cessation of many useless journals. Already, on any big subject, the task of the student, even if he dealt only with abstracts, was almost hopeless.

As for the British medical weekly journals, Professor Bulloch placed them on a plane of value rather below that of their Continental contemporaries. He gave a satirical summary of the contents—voluminous lectures by so-called leaders of the profession, whose contributions were out of date before they were written, some scrappy and badly reported clinical notes, a leader by an anonymous writer (the anonymity depriving the reader of any means of assessing its value); a record of the doughty deeds of the British Medical Association, what the Association did at its last picnic, and what it would do at its next; the Presidential Address, the Address in Medicine, and the Address in Surgery; various conflicting opinions on the Midwives' Registration Bill; announcements of births, deaths, and marriages, and a number of advertisements. The journals which the speaker selected for his unadulterated praise were various monthly or quarterly productions, like *Brain* and the *Journal of Physiology*. Professor Bulloch made merry over the titles of many journals in the States, where there was an organ called *Medical Chips*, and another, said to be devoted to furnishing materials for the use of busy

physicians, called *Medical Snapshots*. There was also a *Journal of Orificial Surgery*, while the number of dental papers, particularly on the Californian coast, was extraordinary.

Medical periodical literature was a necessity. Medical men could not be individualists. They must supplement their own work with the experience—including the contemporaneous experience—of others. From a study of the work of others they might get a clue to the knowledge still required to elucidate some disease. But, notwithstanding this great literature, there were vast lacunae in our knowledge whichever way we turned. Moreover, many affirmations were made in medical literature which had never been tested, and would not bear testing for a moment. He insisted that every quotation should be verified by reference to the original source, or if the original source was inaccessible the intermediate authority should be cited as well. An enormous number of errors occurred in transmission from one periodical to another, and details were added in an unaccountable fashion. The lecturer described his own efforts to trace the real authority for certain statements made in the literature of haemophilia. In instance after instance he found, on appealing to the person who was invoked as an authority for a statement, that that person had not actually seen the case in question, but had heard about it from someone else. Out of 949 papers on haemophilia he and a colleague found only 44 which were written in such a manner as to be useful for formulating some definite statement on the subject of heredity. Every article should have, for index purposes, a distinct title, as concise as possible; such titles as "A Strange Case," "A Clinical Record," "A Difficult Labour," "A Remarkable Tumour," should never appear in medical literature. On the other hand, the title was sometimes so lengthy as to make one wonder why the paper that followed need have been written at all. Then medical writers should always be explicit in their references. "Smith, B.M.J., 1904," was an instance of what to avoid: there were endless people of the name of Smith, and there were two volumes, each of 2,000 pages, of the *BRITISH MEDICAL JOURNAL* for 1904. He also urged that all articles should be signed; anonymous articles or articles with the initials only appended suggested that the writer had something to conceal. Editorial supervision and censorship needed to be very much more vigorous. The publication of the same paper in several journals—mostly for vanity and self-advertisement—was a thing which should be rigorously banned. In the library of the Royal College of Surgeons he had spread out before him not long ago six separate journals all containing the same paper which he checked in all of them paragraph by paragraph.

THE PART OF THE STATE IN THE PREVENTION OF DISEASE.

DR. ADDISON'S CAVENDISH LECTURE.

THE Cavendish Lecture was delivered before the West London Medico-Chirurgical Society on June 17th by Dr. CHRISTOPHER ADDISON, M.P., who took as his subject, "The part of the State in the prevention of disease." The chair was occupied by Dr. F. J. McCANN, President, who said, in introducing the lecturer, that there were few men who, like Dr. Addison, had risen to eminence in two professions. One of the few was Dr. Addison's late Cabinet colleague, Sir Auckland Geddes, now British Ambassador at Washington, and his earlier reputation, like Dr. Addison's, was achieved in anatomy. There was something in the study of anatomy which fitted men for public service. It taught them to grasp and appreciate detail, it fostered accuracy of statement, and, above all, it was a most excellent stimulus to memory. He was glad to think that, as Minister without portfolio, Dr. Addison would still be able to place his ripe experience and mature judgement at the disposal of the Prime Minister. (Applause.)

Dr. ADDISON, after a reference to his close association in boyhood with Mr. Keetley, the founder of the lectureship, went on to speak of the vast loss, not only in terms of money, but of physical and social wastage, which resulted from avoidable causes, and the need that as little as possible of that loss should be projected into the future. In these matters society must depend above all things upon the guidance of well balanced and carefully considered

professional advice of a practical kind, based upon the undoubted findings of experience, and as little cumbered as might be with the pedantry of high words. An opponent had to be reckoned with in the shape of a certain type of latter-day economist who would readily spend millions on armaments, even over and above the demands of the Services, and would urge the Government to shovel out other millions in all manner of doles and subsidies, but in meticulous and unfriendly detail would question every item spent on preventive services, and "will crucify you if you talk of research."

Individual Effort in Preventive Medicine.

By the nature of the case knowledge was always in advance of its application, but the character of the work of the average medical man placed its own difficulties in the way of his making the fullest use of his knowledge to aid in the prevention of sickness generally. As opportunities occurred, and as he was convinced that disabilities arose from faulty habits or conditions, the medical man gave such counsel as he thought would contribute to the prevention of their recurrence; but apart from the fact that these counsels were afterwards forgotten or not observed by his patients, he was often conscious that the causes were beyond either his control or theirs. The energies of the average medical man were devoted to healing the ill effects, and not so much to the removal of the cause, even when this was understood. At the same time the lecturer thought that there was a deficiency in the teaching of preventive medicine, and that this subject did not enter sufficiently into the medical curriculum. The next generation of medical men, he hoped, would have a better opportunity than the existing one for tracing the influence of domestic, social, and industrial habits and conditions upon physical disablement.

Do what they would as individuals, the fact remained that when an attempt was made to deal with the causes, either immediate or predisposing, in such a way as to affect in bulk the incidence of various avoidable disabilities, difficulties arose which were beyond the bounds of individual effort, and various agencies, central or local, had to be made use of. Some of this work could be most suitably done by voluntary effort. As Lord Cave's report had shown in the case of the voluntary hospitals, there was abundant room for an extension of the activities of such agencies. On the other hand, past history and present conditions showed also that there were many public necessities which could only be adequately dealt with by public measures with the authority of the State behind them.

The Question of a State Medical Service.

In connexion with this necessary intervention of the State for certain purposes much needless apprehension and suspicion had been aroused through the persuasions of some that the one panacea for the ills which had to be reckoned with was what was described as a State medical service. If some of those who entertained that idea were to examine the matter a little more closely they would speedily reject the notion that this was or could be a specific. Two things were certain: first, that much of the work to be undertaken in combating avoidable disease and disablement was best done, or perhaps could only be done, by civil or lay effort: secondly, that our countrymen would never consent to have their lives directed by doctors. The truth was that there were no short cuts on the long laborious road that society must follow, and it was more important to survey the country and make sure of the direction and see to the equipment than to arouse hopes—false hopes—of accomplishing the end in view by altered conditions of medical service which left the necessities of the case untouched.

The Cost of National Ill Health.

Dr. Addison proceeded to sketch the history and machinery of local government in its health aspects, enumerating the various public authorities and their functions and financial responsibilities. He mentioned incidentally that there were in the country 16,000 different rating and valuation authorities. He then presented an estimate of the cost of physical disability. Taking only the cost which was met out of money supplied from public sources—that is, from the Exchequer and from local rates

—in the year 1920 for England and Wales, he arrived at the following figures:

	£
Expenditure under Poor Law for medical services	11,000,000
Medical benefit including drugs under National Health Insurance	9,100,000
Infectious hospitals	3,000,000
Expenditure on asylums and for mental diseases generally	2,020,000
Tuberculosis services	1,900,000
Maternity and child welfare services	1,950,000
School medical services	600,000
Veneral diseases services	400,000
Port sanitary services	117,000

This amounted to a total of just over 30 millions. While ignoring the amounts spent privately on medical attendance, it was reasonable to add to this figure the contributions of the public towards the maintenance of the voluntary hospitals, whose expenditure for 1920 was seven millions; also the sums paid in sickness and disablement benefit by the approved societies, which, including costs of administration, amounted in 1919 to £8,700,000. Therefore it might roughly be said that the health services of the State and payments to the sick out of public and quasi-public funds in twelve months in England and Wales amounted to 46 millions. In passing he contrasted this figure with the grant from the State to the Medical Research Council, which last year was £125,000.

Incipient Disease.

An examination had been made for him at the Ministry of Health of the ailments for which insured persons in certain representative towns in 1916 sought medical advice. A very large proportion required medical attention because of colds, nasal and bronchial catarrh, and digestive disorders. His expert at the Ministry of Health came to these conclusions:

1. That the conditions which impair health and even lead to the disablement of men, women, and children, are not chiefly the conditions which kill them, though they may in many cases predispose to mortal disease.
2. That relatively little of the sickness is attributable directly to infectious disease.
3. That a substantial proportion of this disease is preventable.

Dr. Addison said that it had seemed to him for a long time past that in the medical schools more attention might be paid to instruction in the beginnings of disease with a view to the reduction of those so-called minor ailments which were among the most disabling. Any improvement in the facilities for early and mutual consultation among medical men and early access to improved methods of diagnosis and remedial treatment would go far to encourage people to seek help and advice at the beginning of their disorders, when timely treatment might prevent disabling effects from developing.

Lines of Preventive Effort.

The first line of preventive effort was to help and encourage medical research. He was glad to have been instrumental in increasing the grant to the Medical Research Council last year to £125,000, but he reminded the meeting how little this sum signified by pointing out that the 10 millions which was proposed as a grant in aid for miners' wages was equal to the contributions for medical research on the present basis for a period of eighty years. The reason why he had resisted the pressure put upon him in 1919 to bring the Medical Research Committee under the Ministry of Health was because he believed that research should be the handmaid of all, and not be subject to the embarrassments of any departmental or interdepartmental considerations. In the next place, preventive medicine should find a field in the improvement of home and domestic conditions and habits. Mr. S. P. Vivian, the Registrar-General, had undertaken for him a calculation of the money lost owing to tuberculosis. He found that, whilst the average period of sickness benefit for all persons coming on the sick funds of one of the chief approved societies was 4.9 weeks in the year, the average period of sickness benefit in the case of those with tuberculosis was 13.7 weeks. After making liberal allowances, Mr. Vivian could not bring the annual money cost of tuberculosis to a smaller figure than 14½ millions. Tuberculosis was largely a preventable disease, which would yield to the housing and town-planning provisions now available or in prospect.

After a reference to prevention associated with industrial conditions, and to the report of the Health of Munition Workers' Committee, Dr. Addison said that it could scarcely require argument that in a definite effort to improve and develop our preventive health services, not only the goodwill and sympathetic co-operation, but also the direct counsel and advice of those whose business it was to understand these questions was essential. What form this should take was a proper subject for discussion in detail, but the medical profession in the past, through its various associations and societies, had proved itself well able to arrange for such discussion, and he was sure it would do so in the future. He reiterated the need for well-considered effort in such directions as the spread of useful information and instruction, the provision of better housing conditions, the encouragement of research and inquiry, not only into the more strictly scientific aspects of medical problems, but in the field of employment and industrial conditions, and the improvement of facilities for early diagnosis and treatment, aided by better organization and direction of the agencies charged with responsibility in these matters.

In reply to a vote of thanks, which was accorded to him by acclamation, Dr. Addison said that some parts of his lecture were the result of experiences in public life not always gained in the easiest way. It might seem a far cry from the scientific application of medicine to the question of 16,000 different rating authorities, but all these factors were involved. The first step in the national prevention of disease—namely, the consolidation of the State departments—had been carried out, but the second step awaited the active co-operation of the medical profession in preventive directions. If society had had available in some practical form during the last fifty years the guidance of the medical profession in the prevention of disease a much larger advance towards national fitness would by now have been made.

SCHEME FOR A POST-GRADUATE MEDICAL SCHOOL IN LONDON.

REPORT OF THE MINISTRY OF HEALTH'S COMMITTEE.

The Report of the Post-Graduate Medical Committee, appointed by Dr. Addison, then Minister of Health, last January, to investigate the needs of medical practitioners and other graduates for further education in medicine in London, and to submit proposals for a practicable scheme for meeting these needs, was issued on June 18th. The Committee was constituted as follows:

The Earl of Athlone, G.C.B., *Chairman*.
Mr. H. J. Cardale, M.B.
Sir Wilmot Herringham, K.C.M.G., M.D.
Sir George Makins, G.C.M.G., F.R.C.S.
Sir George Newman, K.C.B., M.D.
Sir Robert Newman, M.P.
Sir Edward Penton, K.B.E.
Sir E. Cooper Perry, M.D.
Mr. J. Dill Russell, M.B., F.R.C.S.
Dr. T. W. Shore, O.B.E.

The Report begins by giving a short review of the provision hitherto made. After a reference to the special clinical or laboratory courses arranged from time to time at the undergraduate schools, and attended chiefly by old students each at his own school, a sketch is given of the story of the Medical Graduates' College and Polyclinic, and of the work of the Fellowship of Medicine and Post-Graduate Medical Association since 1918. The action of the Fellowship in arranging courses to meet a sudden and clamant demand which arose after the armistice is praised, and it is noted that the experiment showed the nature of the demand for post-graduate teaching and, by actual experiment, the difficulties by which the position is surrounded. A brief account is given of the work of the West London and the North-East London Post-Graduate Colleges, of the London School of Clinical Medicine, and of certain special hospitals.

Some comments on the ordinary medical curriculum lead up to the affirmation that "the undergraduate course of training alone does not at present equip men and women to practise their profession in a fully efficient way," so that provision is needed for post-graduate instruction to amplify and consolidate what has been learnt prior to

qualification. Additional training and the acquirement of a sense of responsibility immediately after actual qualification being recognized as essential, the opinion is expressed that the only effective way of bringing such opportunities within the reach of every recently qualified doctor competent and anxious to take advantage of them is to increase considerably the number of resident appointments and clinical assistantships. The number of students who qualified from the London medical schools in the year 1919-20 was 579, and it is thought that the number qualifying in any year in the immediate future may be estimated at 500. Though the teaching hospitals cannot provide resident appointments and clinical assistantships for anything approaching this number the Committee considers that the Poor Law infirmaries, the special hospitals, and the general hospitals without medical schools, can be utilized for the purpose.

THE NEED FOR POST-GRADUATE INSTRUCTION AND THE EXTENT OF THE DEMAND.

The Committee considers that the graduates requiring post-graduate instruction may be divided into seven categories:

(a) Graduates who have recently qualified; their needs have been briefly noted above.

(b) General practitioners of some years' standing who require general courses in medicine and surgery. The courses must be simple, practical, and so arranged as to minimize the calls upon the practitioner's time, opportunity and resources. He may wish to have in concise and concentrated form very much the same kind of instruction as the undergraduate is given at the bedside, but he does not wish to attend the same class as the undergraduate. "This," the Committee says, "is natural enough, and we are convinced that any post-graduate instructions, whether of this particular kind or any other, must be organized quite separately from undergraduate work. By this we mean that at the least it must be given at a different time, if not at a different place."

(c) General practitioners who seek instruction in special subjects; they want to keep abreast with latest advances in specialties in which they are interested, and are anxious to attend first-rate instruction at some special hospital or department. "To an increasing extent," it is said, "doctors are working in co-operation, partners take up different specialties in addition to their usual routine duties, so that collectively they can deal with cases . . . to the greater benefit of their patients, and without as much recourse to a consultant as has been the custom."

(d) Graduates from home and abroad who need instruction immediately after qualification, with a view to a higher degree or diploma, such as the M.D., or the M.S., or the F.R.C.S., or the diploma in public health, or that in tropical medicine. With regard to the latter the Committee points out that provision is already made, but it considers that instruction in public health should be better organized. In 1920, it is stated, 120 persons were preparing for the D.P.H. at five of the London schools, and all the other schools undertake to provide instruction if asked for. This is considered to be uneconomic, and it is suggested that an Institute of State Medicine should be formed in direct connexion with the University of London. In addition to providing courses necessary for the diploma in public health the institute might arrange for instruction in forensic medicine, in toxicology, and in industrial medicine, as well as in the relation of the practitioner to the State, his fellow practitioners, his patients, and the community at large. Such a course should be given by a general practitioner of experience. It would be of service to undergraduates who desire appointments or clinical assistantships and are about to be faced with the difficulties of private practice and the complexities of the insurance system.

(e) Officers in the naval, military, Indian and Colonial Medical Services would find civilian post-graduate instruction useful.

(f) Graduates who require facilities for extended medical research find at present little satisfactory provision made for them; the Committee is of opinion that further facilities should be afforded, but in the main at the undergraduate schools.

(g) Graduates from abroad falling into categories (b), (c), and (f) suffer from the lack of organization in London to meet their needs.

Assistance for General Practitioners.

It is pointed out that doctors in general practice, particularly those in category (b), might encounter difficulty in finding time to attend post-graduate courses; especially will this be true in the case of those working in rural areas, who will find it impossible to attend whole-time courses unless a locumtenent of a reliable and satisfactory kind can be obtained. It is suggested that the creation of a "Panel of Substitutes" among recently qualified practitioners would serve the double purpose of providing locumtenents and of encouraging newly qualified persons to seek resident appointments. The panel (or register) of substitutes would be kept by the central post-graduate office. At the same time it is recognized that the young graduate may have difficulty in meeting his expenses, and the suggestion is made that eventually State aid might be given to supplement the emoluments, if any, attached to resident posts or to clinical assistantships. On the other hand, the Committee has considered certain suggestions for offering inducements to general practitioners to attend post-graduate courses, by giving a certificate after successful attendance, by paying the fees of the courses, or even by raising the capitation fee of insurance practitioners on condition that they attended courses periodically. The Committee does not approve "these adventitious aids." It thinks that the man worth having will go to the post-graduate school "out of pride in his work and his profession, if only it is made practically possible for him to do so without encroaching on his meagre annual holiday, which is probably more essential to his efficiency than further instruction." It is, however, suggested that it would be reasonable to provide a locumtenent free to the practitioner attending a course at periodic intervals.

CENTRAL POST-GRADUATE HOSPITAL AND SCHOOL.

The Committee recommends the institution of a post-graduate medical school, attached to a large and well equipped hospital, for practitioners able to devote from one to three months to general instruction, for practitioners desiring further knowledge in special subjects, for officers in the services enjoying study leave, and for graduates from overseas. The school would be the centre of a great teaching organization, in which the special hospitals of London, the Poor Law infirmaries, and the medical schools with their clinical units and research departments, would all find their place. As an integral part of the organization there would be a bureau or central office, established under a committee of management, to co-ordinate the whole system, and with the central office would be included a library, a hostel, and all things necessary to afford full facilities for social intercourse.

The central institution for post-graduate instruction, with its hospital, should be situated in a central district easy of access. The hospital should be equipped in up-to-date fashion, and should have at least 300 beds devoted in the main to medicine and surgery, a comparatively small number being set aside for the chief specialties, so as to give completeness to the teaching in the out-patient departments, which should be very fully equipped. Midwifery and fevers should be studied in the special hospitals, and other special hospitals would be brought into the scheme for the benefit of post graduates anxious to qualify themselves to follow the several specialties. The general wards of the post-graduate hospital, comprising about one hundred beds for medical and surgical cases respectively, might, it is suggested, be divided into three services, the remaining 100 beds being allocated for special diseases in some such proportion as follows: Ophthalmology, 12; skin diseases, 12; gynaecology, 24; children's diseases, 12; venereal diseases, 6; neurology, 12; laryngology, otology, and rhinology, 12; for observation and septic cases, 12. It would be essential

to have a well-equipped pathological department to work in conjunction with the wards; it would be primarily concerned in giving full opportunity for studying the latest methods of examining blood, sputum, etc., and of applying the usual tests, but it might provide accommodation for a few graduates wishing to carry out research in some particular branch of pathology. The general features of the plan proposed are shown in the accompanying diagram.

The Conduct of the School.

Medicine.—Instruction would be given daily in the mornings in the out-patient department by the assistant physicians; in the afternoons the physicians would take classes in the wards in the usual manner. On one day a week all the physicians might combine to give demonstrations and discuss selected cases in the wards for the benefit of all attending graduates. The resident house physicians, who would be of senior standing, would receive an honorarium for teaching, and would be responsible for some share in the training of the graduates in attendance.

Surgery.—A similar procedure would be followed.

The follow-up departments would be organized under the physicians and surgeons who to this extent at least should share in the out-patient work.

Special Demonstrations.—Late afternoon sessions (5 to 6.30 p.m.) should be arranged for special demonstrations by distinguished consultants not on the regular staff of the hospital. A consultant in medicine or surgery would give

one demonstration a week for ten weeks, but in some of the special subjects it might be unnecessary to provide for more than two or three demonstrations. These afternoon demonstrations would be given by the leaders in the subjects, and arrangements might be made during university vacations for eminent specialists from the provinces and Scotland, or from overseas and foreign countries, to share in the work. The beds at the central hospital allotted to special subjects might be used for these demonstrations, but it would also often be practicable for the specialist to bring with

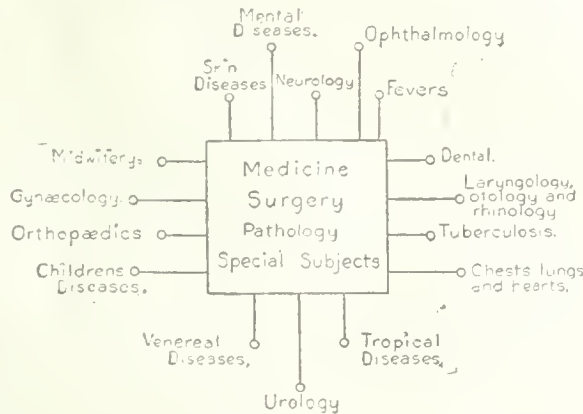

him cases to illustrate his exposition or to hold demonstrations at his own hospital. General practitioners living at no great distance and able to attend only one or two afternoons a week might take advantage of these special demonstrations. Courses, with practical instruction, should be arranged in general and chemical pathology, bacteriology, and serology. Comparative pathology would be a proper subject for post-graduate study should the university be able to carry out the proposals put forward for the establishment of an institute of comparative pathology in conjunction with Brown's Animal Sanatory Institution and perhaps the Royal Veterinary College.

Therapeutics and Applied Anatomy and Physiology.—Courses in these subjects might be arranged at the central school, and pharmacology might be treated from a post-graduate point of view by means of special courses elsewhere under arrangements made by the central school.

Special Hospitals.—It is recommended that the great special hospitals should be closely associated with the central hospital and that the departments of the undergraduate schools should be regarded as special hospitals for the purposes of the scheme. Provision for dental training, would be made at the Royal Dental Hospital, and at existing dental departments attached to the general hospitals with teaching schools.

Staff of the Central Hospital.

The Committee recognizes that the staffing of the central hospital and school presents difficulties, especially if, as is considered desirable, an existing hospital and undergraduate school is converted into a post-graduate school. At the same time the difficulties are not considered

fundamental, and one at least would be diminished if the centre chosen for post-graduate instruction is already a school of the University of London, for the Senate is not likely to raise any objection to its continuance as such, even though its activities were limited to post-graduate work and to research. In this case it would continue to be managed as at present, but the general control of the system of post-graduate education would be assigned to the committee of management of the central office described below. The Committee is of opinion that the conversion of an existing hospital and undergraduate school is the best way of forming a post-graduate school, and points out that if the post-graduate centre achieves the success that is confidently hoped, it would be a unique institution with which it would be a high honour to be associated. If an existing school were converted the present staff would continue to serve it, strengthened as far as necessary by any suitable additions. It is, however, considered desirable that one of the three services in medicine and surgery respectively should be placed in charge of a physician or surgeon who is not a regular member of the hospital staff; he might be a distinguished past or present member of the staff of one of the undergraduate schools, and the duty might be taken in rotation for a period of three months by a series of physicians and surgeons.

Details of Staff and Finance.

On the assumption that the hospital service would be provided by the governors on the same scale as at undergraduate hospitals the following suggestions are made with regard to the constitution of the staff and the remuneration of its members.

Medicine and Surgery.—Three physicians or surgeons each receiving an annual honorarium of 100 guineas; three assistant physicians or surgeons with an annual honorarium of 200 guineas; three resident house officers with a salary of £200 a year with board and residence. The total for each service would be about £1,500 a year.

Pathology.—A full-time professor debarred from private practice and receiving a salary of £1,200 to £1,500, together with superannuation provision, would be required. As the subject would include bacteriology and serology, chemical pathology, morbid histology, and *post-mortem* examinations, full-time lecturers would be required to deal with branches of the subject other than that to which the head of the department devoted himself. The department would provide for instruction of post-graduates and for some research work; its total annual budget, including laboratory maintenance, would be about £4,000.

Special Departments.—A physician or surgeon would be required in each special department, and provision should be made also for teaching therapeutics and applied anatomy and physiology. The estimated cost of these departments and branches is £2,500.

Special demonstrations would be paid for at the rate of about ten guineas a demonstration; the cost it is estimated would be £2,000 a year.

Associated Hospitals.—Payment of the teachers at the special hospitals associated with the central hospital would be regulated by the extent of the demand, but it is estimated that an annual outlay of £1,500 would be required.

Superannuation.—The contribution of the school to the federated superannuation system of the universities on behalf of the full-time members of the staff of the post-graduate school would be £1,000 a year.

The total annual cost of the staff would thus be approximately £14,000.

Central Office.—The establishment of a central office easily accessible from the central hospital is recommended. It should be under the charge of a whole-time principal officer with a medical training, working under a committee of management. This committee should be appointed in the first place by the Privy Council, and should be fully representative of general practitioners and the principal educational bodies. The salary of the principal officer should be £1,500 a year, and he would be provided with an adequate clerical staff. In addition to providing accommodation for the principal officer and his staff the central office should be so arranged as to serve as a convenient meeting place for post-graduates; it would contain a library, a reading room, and a restaurant; it would be desirable to have a hostel also. It is estimated that the annual expenditure would be £4,000.

Financial Summary.

If the recommendations of the Committee were carried out a total annual revenue of £28,000 would be required—namely, for the teachers £14,000, for the central administration £4,000, for the Institute of State Medicine £10,000. There are only two sources from which this income can be derived—namely, the State or private endowment; local support from rates, the Committee points out, could not be expected for a series of institutions of a national character,

and "the course fees paid by post-graduates should, we suggest, be allocated for capital purposes." If the school and the institute were constituent parts of the University of London, as the Committee recommends, they would be eligible for inclusion on the list of grant-aided university institutions, and the Committee hopes that an annual grant of sufficient amount will be favourably considered by the University Grants Committee and the Treasury. If an undergraduate school were converted the grant at present given to that school would provide in part for the annual grant without additional cost to the State. In addition to the annual revenue considerable capital outlays for initial equipment and adaptation of premises for the school, the central office, and the institute, would be required. The Committee expresses the hope that the University Grants Committee might consider the possibility of making a capital grant for initial equipment and for social purposes on the basis of £ for £ contributed from other sources.

Provincial Areas.

The reference to the Committee did not instruct it to make recommendations with regard to provincial areas. While the Committee considers that the plan outlined will serve the purposes of a much wider area than London itself, there will remain a provincial demand to be met by the universities at the great centres, and they have already taken the matter into consideration.

ROYAL MEDICAL BENEVOLENT FUND.

At the meeting of the Committee held on June 14th twenty-seven cases were considered and £382 voted to twenty-three applicants. The following is a summary of some of the cases relieved:

Widow, aged 42, of M.B. Dublin who died in 1915. Applicant had nervous breakdown two years ago and sold her furniture to pay expenses, and only within the last few months has she been well enough to try to support herself and children. She receives £25 subscribed by medical men and invested with the Public Trustee, £30 from Devon and Exeter Medical Society, and £50 from a brother-in-law. Voted £18 in two instalments.

Daughter, aged 67, of M.R.C.S. Eng. who died in 1878. Three daughters were left to support themselves; one died recently who helped with the house. Their sole income is derived from letting apartments. Applicant and her sister, owing to indifferent health, find the work very trying. In 1910 and 1911 the Fund helped this case to the extent of £22. Voted £18 in twelve instalments and a special grant of £6.

Widow, aged 63, of L.R.F.P.S. Glasg. who, when the war broke out, went as a surgeon on transports engaged by different shipping companies, and not coming directly under the Admiralty was not entitled to a pension. Applicant is an invalid. Her son allows her £4 per month; the youngest daughter is out as a cook, but unable to help her mother financially. Voted £12 in twelve instalments.

Widow, aged 45, of L.S.A. Lond. who died in 1921. After paying funeral expenses and debts out of the insurance of £100 applicant had so little left that she applied to the Public Trustee for an advance of £20 pending the settlement of her father-in-law's estate, which is expected to realize about £60 per annum. The eldest girl earns 14s. per week and board; the youngest is undergoing three months' training as a shorthand-typist, the fees being paid by a neighbour. Voted £10.

Daughter, aged 36, of L.R.C.S. Edin. Applicant has supported herself by literary work, but owing to a nervous breakdown has been unable to carry on work, and was dependent on friends. She came under the notice of the Charity Organization Society, who applied to the Fund on her behalf. She was found to be very ill and near starvation. Another society sent her away for six weeks to regain strength, and ask for a grant towards the cost. Voted £15.

Subscriptions may be sent to the Honorary Treasurer, Sir Charters J. Symonds, C.B., F.R.C.S., at 11, Chandos Street, Cavendish Square, London, W.1.

The Royal Medical Benevolent Fund Guild is overwhelmed, in these days of exorbitant prices for clothing and household necessities, with applications for coats and skirts for ladies and girls holding secretarial posts, and suits for working boys. The Guild appeals for second-hand clothes and household articles for the benefit of the widows and children who in happier times would not have needed assistance. The gifts should be sent to the Secretary of the Guild, 43, Bolsover Street, W.1.

THE Labour Department of the United States has equipped a number of automobile dispensaries for child welfare work in country districts; each dispensary has a staff consisting of a woman doctor, nurse, driver, and conductor.

THE French Government announced recently that a premium would henceforward be paid for children born in France. In the provinces 300 francs will be paid for third infants, the scale being gradually increased to 650 francs for the tenth child; in Paris the premiums will be increased 50 per cent.

British Medical Journal.

SATURDAY, JUNE 25TH, 1921.

THE POST-GRADUATE SCHOOL REPORT.

As was to be expected from the constitution of the Post-Graduate Medical Committee, its report is a workmanlike document which makes certain definite proposals and is free from superfluities; we could, indeed, have wished that it had discussed one or two points more fully. It presents a scheme for meeting the wants of general practitioners and other post-graduates who are willing to devote a definite period to whole-time instruction of a general or specialist nature; it definitely recommends that for the proper provision of the necessary facilities a post-graduate medical school should be instituted in a central part of London and that a large and well-equipped hospital should be attached to it. In making this recommendation the Committee arrives at a conclusion which was reached by the Fellowship of Medicine more than a year ago: the Committee, indeed, pays a high compliment to the amalgamated Fellowship of Medicine and Post-Graduate Medical College when it says that one great service rendered by the courses instituted at the beginning of 1919 was to show the nature of the demand for post-graduate teaching, and the extent and variety, demonstrated by actual experiment, of the difficulties with which the position is surrounded. One of the difficulties, as has all along been realized, is that the possible attendants at a post-graduate school will not all want the same sort of instruction and opportunity. The Committee, indeed, as will be seen from the full account of the report given elsewhere (p. 942), makes out that there are seven different classes of post-graduates, although it must be admitted that the wants of some of the classes do not differ fundamentally from those of some others: as, for instance, (a) graduates who have recently qualified, and (b) graduates seeking a higher degree or diploma.

Another difficulty is that, to put the matter rather crudely, the staff of no one hospital can, under any conceivable conditions, be strong enough to be representative of all that is best in London. The Committee seeks to meet this objection by two suggestions, both ingenious and both, we believe, feasible. It will be observed that the Committee proposes that the hospital of the post-graduate school should have at least 300 beds, of which 100 would be for the medical service, 100 for the surgical service, and the remainder divided in certain proportions among various specialties. To bring in teachers not directly attached to the staff of the hospital it is proposed that the 100 medical and the 100 surgical beds should be divided each into three services, and that at the head of one of these services in each case should be a distinguished past or present member of the medical or surgical staff of an undergraduate school, who would take his turn in rotation for a period of three months. In the next place it is suggested that special demonstrations should be given by distinguished consultants not on the regular staff of the hospital; each would give one demonstration a week, for ten weeks as a maximum, the hour fixed being, for the convenience of general practitioners in the neighbourhood, late in the afternoon. The scheme presupposes proper medical

school buildings, with lecture rooms and laboratories. It is considered possible that the specialist giving the demonstrations might bring cases to illustrate his exposition to the Post-Graduate Hospital or might hold his demonstration at his own hospital—whether a special hospital or a general hospital with a medical school—the demonstrations in the latter case being so timed as not to clash with undergraduate instruction. Beds assigned at the Post-Graduate Hospital for special diseases might, however, be utilized, and the scheme contemplates the possibility of eminent specialists from the provinces and Scotland, or even from overseas dominions and foreign countries, taking their share in the work during university vacations. It is proposed to pay fees for the demonstrations, to give the physicians and surgeons of the post-graduate hospital an honorarium, to pay the residents salaries, and to engage whole-time professors and whole-time lecturers in the department of pathology. The cost of all this would, it is estimated, be £14,000 a year, and the central office would cost £4,000 a year. In addition some capital expenditure would be necessary, which might be considerable unless it were possible to take over an undergraduate school as a going concern. There is general agreement that there are too many undergraduate medical schools in London, though when it comes to selecting the particular school which is superfluous, agreement ceases; still, as the Committee points out, the post-graduate centre, if it achieves the success that is confidently anticipated, will be a unique institution with which it would be a high honour to be associated.

The report does not say what is to happen to the West London Post-Graduate College, or the North-East London Post-Graduate College, and we cannot suppose that they will allow themselves to be snuffed out. The Fellowship of Medicine might continue to do the social work, particularly among overseas or foreign visitors, for which it was instituted. The plan for "a panel of substitutes," to consist of recently qualified practitioners who would act as locumtenents for practitioners attending post-graduate classes, is interesting and ingenious. The Committee thinks it hardly possible, however, that it could be realized without a subsidy, direct or indirect, and were the rest of the scheme to be delayed on this account it would be regrettable.

When we ask ourselves what prospect there is of the recommendations of the Committee being carried out, we cannot but regret the introduction into the scheme of a plan for an Institute of State Medicine. We do not doubt that in the present temper of the country and of the House of Commons, objection to the scheme will be taken on the ground of expense. The proposal with regard to an Institute of State Medicine adds something like 50 per cent. to the total annual expenditure the recommendations of the Committee would involve, and we are decidedly of opinion that the establishment of such an institute, although theoretically advisable, is, as a matter of practical politics, not urgent. Excellent training for the examination for the diploma in public health can be obtained both in London and other centres, and we have not heard that candidates have ever experienced any difficulty in obtaining the facilities they needed.

It is a reproach to London, as everybody must be growing tired to be told, that it has not got a post-graduate medical school worthy of it. We may well be grateful to Dr. Addison for appointing the committee which, under the guidance of the Earl of Athlone, chairman of the Middlesex Hospital, has presented the Government, Parliament, and the public with a very clear statement of the situation and a

bold plan for remedying deficiencies which have long been the cause of anxiety to those jealous for the honour of British medicine. We earnestly hope that the recommendations of the report may early receive the attention of Dr. Addison's successor. The matter has two aspects, the national and the international, and in respect of the latter time is of great importance. Many teachers who themselves frequented Vienna and Berlin are sending foreign, and perhaps also overseas, post-graduates to these cities, whereas it is to the interests of this country from many points of view to attract them to London. Already there has been two years' delay: perhaps it was inevitable, but further delay is not inevitable. We hope also that the University of London will show itself alive to the necessities of the situation, and that the Senate will be disposed to encourage the conversion of an undergraduate school into a post-graduate school.

A NEW STUDY OF APHASIA.

II.

In a preceding article some account was given of the position to which the theory of aphasia had been advanced by the labours of Hughlings Jackson and Pierre Marie, and it was shown how Head's examination of Jackson's opinions brought us back to Locke's view that language is the use of articulate sounds as marks or signs of ideas within a man's own mind whereby they can be made known to others. We propose now to consider some of Dr. Head's own most recent observations.

During the war he examined many young and healthy patients who, from head wounds, had developed slighter and more specialized defects of speech than are met with in disease. They were for the most part intelligent and anxious to improve. Even had it not been clearly appreciated before, it would have been obvious from observation of this class of patient that there is no single psychological function or faculty corresponding to "speech." Dugald Stewart saw this when he remarked that "words only convey hints." Gradually societies of men agree amongst themselves to limit the scope of hints conveyed by particular words and phrases until a conventional dialect is arrived at. Words have no natural signification; the idea which each stands for must be learned and retained by those who would exchange thoughts. But words are not only the names of ideas in the mind: they are also the signs of the connexion that the mind gives to ideas one with another.

No lesion can affect speech and speech only. Cerebral injury only disturbs the complex act called "speech" by interfering with certain physiological processes which underlie the use of language. As Head shrewdly put it, "we should as soon expect a special centre for eating as for speech." This idea will come as rather a shock to those who have been brought up on the current teaching, with its terms "motor" and "sensory" aphasia, "alexia," "agraphia," and "amnesia verbalis." We had almost come to regard the faculty of speech as consisting of word-clusters pocketed away in definite centres in the brain which could be destroyed piecemeal and independently of other cerebral faculties. Head reminds us opportunely of Hughlings Jackson's division of language into emotional and intellectual. It is eminently helpful and practical; once grasped it is never forgotten and proves a key to unlock many doors. Emotional utterance is phylogenetically developed earlier and in the presence of injury or disease is retained longer. It enables man in common

with the lower animals to exhibit states of feeling. Intellectual language is developed later and consists in a power to convey ideas or propositions by gesture, vocal sounds, and by written signs. When the physiological processes which subserve the complex act of speech are disturbed, words, numbers, pictures, and every function which depends upon the use of symbols in constructive thought, may be affected. From what has gone before the reader will be prepared to learn that Head does not allow that language can be considered to be a function apart; it may suffer impairment in common with any mental process which demands for its performance exact comprehension, voluntary recall, and perfect expression. We cannot set definite limits to the processes involved, we do not know them. Head suggests that the whole group of allied processes might be spoken of as "symbolic thinking and expression," because it is mainly the use of words, numbers, and pictures which suffers in aphasia and kindred disorders. He warns us against regarding the term as in any way defining the group of processes affected and would have preferred some entirely indifferent term if one had been available. Hughlings Jackson had used the word "propositionize" to represent the mental processes which precede the intelligent use of language. Loss of language for both Hughlings Jackson and Head is, as we understand them, primarily a defect in formulating ideas, and secondarily a defect in correlating ideas to men's arbitrary signs, whether spoken or written words or gestures.

Locke discussed some of the difficulties to be encountered in analysing the nature of language. He pointed out that in the first place the ideas words stand for may be very complex, and made up of a great number of ideas put together; and that, in the second place, the ideas they stand for may have no certain connexion in nature, and no settled standard by which to rectify and adjust them. Thirdly, he observed that the signification of a word may be referred to a standard which is not generally or easily known, and finally he maintained that the signification of the word and the real essence of the thing may not be the same. Locke offers the definition we are looking for: "Words are the voluntary and unsteady signs of men's own ideas." Head's phrase "symbolic action" seems intended to cover all the possible uses of these unsteady signs.

The whole difficulty of adopting Head's views seems to lie in the acceptance of two particular terms: Jackson's "propositionizing" to represent the process of getting ready in the mind a concept or idea in such a shape that it may be communicated to others, and Head's "symbolic action" to represent the utterance of those signs or marks which, if employed according to the conventional dialect of a man's neighbours, will convey to them the idea or sequence of ideas which have been marshalled in his mind. In a concluding article the classification of conditions which Head proposes will be explained.

RESIGNATION OF PROFESSOR SIR HALLIDAY CROOM.

THE Court of the University of Edinburgh, at its meeting on June 13th, received with great regret the resignation of Professor Sir J. Halliday Croom from the Chair of Midwifery and accepted with grateful thanks a gift by the Professor of all the preparations, specimens, apparatus, and diagrams which he had collected during his tenure of the chair. It was known during the session that Sir Halliday Croom intended to resign before the beginning

of another winter, and at the close of his class in the university in March last he bade farewell to the men of the year in characteristically beautiful and thought-laden words. Some parts of this valedictory address were published in *The Student* for May, but it is to be hoped that in its fullness it may be made available for the reading of Sir Halliday's former pupils scattered all over the world. What a teacher has to say of his work after nearly fifty years' devotion to it cannot fail to be interesting; and when, in addition, large numbers of eager undergraduates attended that teaching all these years, interest deepens into absorbing, impressive, and rapt attention. Examples of the Professor's pithy, picturesque, sometimes pungent, and always arresting and memorable phrasing were not wanting in the farewell address. "Obstetrics can never be relegated to a second place in the curriculum. . . . As I have often said to you, in medicine and surgery you can fall back on the advice of your colleagues or on eminent specialists, but in the dramatic incidents of private obstetric practice you must work unaided and alone. . . . You are the lineal descendants of Goodsir, Simpson, Lister, Christison, Lylecock, Syme, and Bennett. . . . Can I make a stronger appeal than the old words, *Noblesse oblige*? . . . Let me assure you that to live is sometimes very difficult, but it is never meritorious in itself, and we must have a reason to allege to our own conscience why we should continue to exist on this crowded earth. . . . I am optimistic enough to re-echo Whittier's article of belief, and to make my last adieu to you all in his words, so full of good cheer and of eternal hope: 'Of course the world is growing better; the Lord reigns; our old planet is swinging slowly into full light. I despair of nothing good. All will come in due time that is really needed, and all you have to do is to work and wait.'" The class was not lacking in its recognition of Sir Halliday Croom's outstanding merits as a teacher, and in presenting the retiring Professor with a silver-mounted walking-stick and a silver cigar box from the present and from some of the former students, Mr. A. M. MacLachlaine said some true things in a felicitous way. "Coming to your department as to a somewhat dry and unromantic study, we have found you not, certainly, miscalling technicalities, but, so to speak, handing us a chair, and illustrating the minutiae of your art with aphorisms and modern instances ranging from the peerage to the byre." In speaking of the Professor's constant kindness shown to his pupils, Mr. MacLachlaine provoked a smile with his remark, "Sir, the medical student, like other wildfowl, responds to kindness." The undergraduate, with unerring instinct, laid emphasis, too, upon the outstanding attractiveness of Sir Halliday's lectures when he spoke of their aphoristic and vivid phraseology. Sentences minted in the midwifery class-room have over and over again become current coin in the University. Carlyle may have called man a tool-using animal, and the French have defined him as the cooking animal; but it needed Sir Halliday Croom to describe woman as a being with a Curve of Carus, throwing a sudden spotlight on this modest and retiring anatomical feature, and showing it up as a feature of generic import. Sir Halliday Croom's resignation of the Midwifery Chair has coincided with the completion of his term of office as Chairman of the Central Midwives Board for Scotland, and has involved his departure from the acting staff of the Royal Maternity Hospital; but he is still hale, hearty, full of life, keen of mind, and imbued with what he himself spoke of as the enthusiasm of humanity, and Edinburgh and his colleagues rejoice in his continued presence in their midst. If he finds time hanging heavily upon his hands a volume from his pen on Medical Edinburgh in the seventies of the past century would be a delightful book of remembrance as well as a joy to the lover of those less recent days when John Hatton Balfour spoke of "woody fibre," when Crum Brown (still alive and well at a great

age) set off explosive mixtures in the chemistry class-room, when Hughes Bennett and Lylecock saluted one another, when Sir William Turner ruled in the anatomy department and "vexed all very nervous pupils," when Sir Robert Christison tried the effect of swallowing calabar bean on an empty stomach, when Spence was said to be somewhat "dismal" in surgery, and Lister was brilliant in invention, when Sir Wyville Thomson described in prismatic eloquence the beauties of the jelly-fish of tropical seas, and when Sir Alexander Russell Simpson (Sir Halliday Croom's friend and predecessor in the chair) had, perhaps, his own brilliancy a little obscured by the exceeding brightness of his uncle's fame. It is understood that Sir Halliday Croom has expressed abhorrence for anything and everything of the nature of reminiscences; but will he not "take another thought" and give to his many friends the real gift of a sketch of the Edinburgh Medical School in the seventies?

PROTECTION OF RADIOLOGICAL WORKERS.

THE X Ray and Radium Protection Committee, the constitution of which was announced in the *JOURNAL* of May 28th, 1921, has now issued a preliminary report which we print in full this week at p. 936. The Committee was set up by a number of metropolitan organizations interested in radiology. The chairman is Sir Humphry Rolleston. In view of the constant demand for guidance from individuals and institutions it was thought desirable to issue an early statement on the means for the protection of the worker, and the present report accordingly gives an outline of existing knowledge with regard to equipment, ventilation, and working conditions of x-ray and radium departments. After the completion of this, the most pressing part of its work, the Committee will proceed further with the collection of data bearing on the effect of irradiation, with special reference to protection. Researches will be undertaken and further reports published from time to time. It will be observed that the preliminary report opens with the positive statement that the danger of over-exposure to x-rays and radium can be avoided by the provision of efficient protection and suitable working conditions; it is, therefore, the duty of those in charge of x-ray and radium departments to ensure that this provision is made for their workers. Although the Committee believes that an adequate degree of safety would result if the recommendations now put forward in some detail were acted upon, it insists that this protection depends entirely upon the loyal co-operation of the workers in following the precautionary measures advised. The Committee further recommends that periodic tests should be made of the blood of the personnel, so that any changes may be recognized at an early stage. This is necessary because susceptibility to radiation is not constant for all workers, and in the present state of knowledge it is difficult to decide when small variations from the normal blood count become significant.

THE IDEALS OF A BELOVED PHYSICIAN.

IN 1905 Dr. C. N. B. Camac of New York brought out, with the consent and guidance of his old teacher, a volume of *Counsels and Ideals*, selected from forty-seven of Sir William Osler's writings. This attractive collection of *obiter dicta*, representing Sir William's philosophy of life down to the time when he took up the duties of the Regius Professor of Medicine at Oxford, met such an immediate and well-deserved demand that within two years a fourth impression was required. In 1918 the book went out of print on account of the loss by enemy submarine action of a consignment for the American market. During his fatal illness Sir W. Osler had the possibility of a second edition in mind, and now, though with some hesitation from the consciousness that he had to act without the help of his former guide, Dr. Camac,

has most successfully accomplished this trust.' The additions, drawn from twenty-six addresses and papers published since 1904, form an appropriate summary of the Regius Professor's general teaching in Britain, and, as in the case of the first edition, leave the reader with the desire to possess, and pick out his own favourite passage from, the originals, some of which are, unhappily, not very easy of access. Comparison of the American with the Oxford period shows that the message of the later series is directed to the further evolution of methods and institutions outlined and advocated in the earlier addresses. The second edition contains an unfamiliar photograph of Sir W. Osler, which though at first sight disappointing grows on one, and a thoughtful and discriminating appreciation by Dr. Cainac, who points out that the reforming influence of the medical leader was greatly enhanced by a most exceptional personality, and that his great achievement—the establishment of a system of training in school and laboratory—was thus rendered possible. The secret of his great influence was human sympathy scattered through all his dealings with his fellows. His literary style is described as showing, in addition to the epigram, an element of surprise, climax and apt quotation constantly sustaining interest. In conclusion, *Counsels and Ideals* should most certainly be added to the Bedside Library list drawn up some years ago by Sir William Osler in order to render the medical student's education "if not of a scholar at least that of a gentleman."

THE FUTURE OF PHARMACY.

THE British Pharmaceutical Conference was held in Scarborough last week, under the presidency of Mr. E. Saville Peck, M.A., of Cambridge, who, in an address on British pharmacy and its possibilities, declared the present position of pharmacy to be unsatisfactory. He considered that a wider preliminary education for those entering the calling was necessary, and suggested that candidates for registration as apprentices and students of the Pharmaceutical Society should be required to pass one of the school-leaving certificate examinations. With a view to stimulating a professional spirit in the rank and file of pharmacists, he suggested that the local associations should discuss pharmaceutical professional matters and should send delegates to the annual conference, so that the considered opinions of members might be focussed for the information of the council of the society. He advocated the formation of an association of teachers from the various schools of pharmacy, which would meet annually for discussion. He advocated also the establishment of a university degree in science with pharmaceutics as one of the final subjects, and strongly urged the institution of a fellowship examination, to include biochemistry and bacteriology, and clinical microscopy, with a view to training students to carry out clinical analyses, and so assist in the diagnosis of disease. They were needed also by wholesale houses to undertake the preparation of vaccines and for research upon new drugs and remedies. Other suggestions contained in the address were as to the need for pharmaceutical research, the advisability of the separation of the prescribing and dispensing of medicines, and the institution of an Army Pharmaceutical Corps. It will be seen that Mr. Peck does not lack courage in the claims he makes for his calling. We agree as to the desirability of raising the standard of preliminary education, and agree also as to the need for pharmaceutical research, although it may be a little difficult to define the boundaries between it and pharmacological research. We are less clear about the advisability of training pharmacists in biochemistry, bacteriology, and microscopy, with a view to their taking charge of the clinical laboratories attached to the

primary and secondary centres described in the Dawson Report. This is what we think Mr. Peck means, and we are aware that the possibility of some such plan was recognized in the Report, but, unless we are very much mistaken, it was intended to apply to the primary centres only. We are by no means satisfied that the plan would work well even in the primary centres, and it would take a good deal to convince us that it is applicable to the secondary. We are inclined to think—and it is in this sense we read the Dawson Report—that the laboratories of the secondary centres must be in charge of a fully equipped medical director, who would have the help of a suitable laboratory assistant, for whom, we think, the training in pharmacy, biochemistry, and bacteriology suggested by Mr. Peck would be superfluous.

MENTAL THERAPEUTICS AND THE PUBLIC.

MORALISTS have always been concerned with the problem of the mental and moral weakling, but their attitude towards it has from age to age undergone profound changes. Thus, at one epoch the mentally and morally feeble were regarded with awe, at another with contempt, and at yet another with active intolerance; and in recent times with a sympathy so broad as to amount to an exoneration of all culpability. The same problem has always faced the medical man, who has endeavoured to solve it on the lines of common sense and experience; he has had a great measure of success, but it is only of late years that a serious attempt has been made to bring it within the field of the scientific method; it has been possible to do this only through the rapid growth of psychological knowledge. The prominence that has been given to mental analysis in the newspapers and monthly periodicals, as well as by writers of fiction, and the large number of irresponsible people practising it, call for the serious attention of the medical profession. Certain sections of the Churches have already defined their attitude. It should be emphasized that mental analysis is a grave operation on the mind, and should only be embarked upon in the same spirit as a serious surgical operation. It is an exploration, the operator having no knowledge beforehand of what he is going to find. Put in another way the whole process is a confession under duress, and the subject of it makes a present of his or her identity to the examiner. All the most intimate memories, desires, hopes, fears, tendencies, experiences, indeed the whole complex constituting the individual, have been surrendered to someone else. And it may be observed here that unless the analyst is convinced that his knowledge of the case before him is that of the true individual he will fail in his object. Thus the relationship between the patient and the examiner is a sacred one, since it involves the opening of the secret chambers of the personality. Once the sanctity of the process is admitted the need for discrimination becomes apparent. No one can lightly undertake to analyse another's mind; no one should lightly consent to be analysed. The necessity for analysis in this instance postulates the need for synthesis. The synthetic process involves considerations of environment, conditions of existence, relationship with other lives near and remote. The advice tendered in respect of the new life which the patient is to live must be tempered with a high conception of morality, or he or she cannot be reclaimed and made once more into a social being. The mere conversion of an inefficient mind into an efficient machine is a different question; it is not preceded by analysis, and can safely be left to competent teachers of mental training. But where analysis is a necessary preliminary the operator's responsibility is enormously increased, and the public should exercise the utmost discretion in its choice. The daily press recently furnished an instance of the practice of psychotherapy by an unqualified person, the end-result of which was an inquest. This may be an

¹ *Counsels and Ideals from the Writings of William Osler*. Selected and edited by C. N. B. Cainac. Second edition, with extracts from articles appearing since 1904. London and New York: Humphrey Mitford. 1921. (Cr. 8vo, pp. 379; 1 plate. 8s. 6d. net.)

extreme instance, but it serves to accentuate the point that (laying aside any question of the operator's analytical and reconstructive skill) the selection of cases for treatment is as difficult and delicate as it is important. Whatever the future may reveal, there is no doubt that in the present state of our knowledge the competent and proper person to make this selection is the medical practitioner, who alone is in the position to take full responsibility. Quackery, in the ordinary sense of the word, may not be actively harmful, but mental quackery is worse than witchcraft.

THE ROYAL SOCIETY OF MEDICINE.

A SPECIAL general meeting of the Fellows of the Royal Society of Medicine was held at the Society's house, 1, Wimpole Street, on June 10th, to consider three resolutions of the Council concerning the *Proceedings* of the Society and the subscription. At a previous meeting, on April 25th, the Council's resolution regarding the raising of the subscription was met by an amendment, proposed by Dr. H. H. Dale, that while the subscription should be raised, one guinea should be remitted from the subscription of Fellows who did not desire to receive the *Proceedings*. This amendment did not obtain a majority large enough to make it operative, but in face of the discussion to which it gave rise the Council underbroke to reconsider the matter, as it was evident that the majority of the Fellows of the Society agreed that too much of the revenue was being spent on the *Proceedings*. Before the meeting on June 10th a statement by the treasurers was circulated, showing that the large deficit of 1920 was due to the sudden increase in the cost of the *Proceedings*, amounting to about £4,000 over that for 1919, which in itself was well above the average of previous years. If the resolution before the meeting were passed £4,000 only would be allowed for *Proceedings*, while £1,500 would be allotted to the library, in accordance with the Council's resolution of October, 1920. The resolution, "That the By-laws be altered so as to provide that the *Proceedings* of the Society shall be published under the direction of the Council as regards arrangements for publication and the financial cost incurred, but this shall not interfere with the right of each Section to decide what shall appear as its own *Proceedings*, subject only to the financial limitations imposed by the Council of the Society," was proposed by Mr. Fagge and seconded by Dr. H. H. Dale; after a short discussion it was passed by 119 votes to 21. The second resolution, which concerned the copyright of papers accepted by the Society, was a merely formal rectification of an already existing By-law; it was adopted on a show of hands. The third resolution, "That the By-laws be altered so as to provide that the subscriptions of all Fellows in the London Postal Area be five guineas per annum, and that the subscriptions of all other Fellows in the United Kingdom be four guineas," provoked some discussion. The difference in the use made of the Society by Fellows residing close to the Society's house and by those living in the provinces or more distant parts of London was pointed out, and it was suggested that many of them might, on the raising of the subscription, resign the Fellowship, though some might wish to remain members of a Section. Since 1914 the number of Fellows and Members has increased from 2,842 to 3,369, but it was suggested that this total is really very small, and that if the work of the Society and the manner of election to it were better known, it might be greatly increased and the finances of the Society placed on a sounder footing. It seemed, however, to be more or less generally recognized that under present conditions the subscription had to be increased, and the resolution was passed by a majority of 107 to 35. At this meeting the freedom of debate was hampered by the fact that it was called for the alteration of by-laws, so that discussion was limited, no amendment being in order and only a direct vote, Yes or No, possible. The annual

meeting of the Society, which is to take place on Wednesday, July 6th, will afford greater latitude for discussing its future, and we venture to express the hope that means will be found to place its finances on a satisfactory basis. Sir Malcolm Morris has given notice that he will at this meeting move the appointment of a Committee of Fellows "to investigate the administration of the Society with a view to suggesting economy and improvements, and that it be authorized to obtain, if necessary, the aid of a chartered accountant." It was a great achievement to bring about the amalgamation of the numerous medical societies which exist in London, and Fellows may be reminded that in many instances the amalgamation enabled them to effect some economy in their list of subscriptions. The alteration in the by-laws by which the Council now has control over the expenditure Sections can incur in the production of the *Proceedings* will in itself tend materially to improve its position.

THE OXFORD OPHTHALMOLOGICAL CONGRESS.

THE twelfth Oxford Ophthalmological Congress will be opened on Thursday, July 7th, by the Master, Mr. Sydney Stephenson. A discussion on the causes of infection after extraction of senile cataract will be opened by Dr. Victor Morax, of Paris, who will maintain that by the improvement of surgical technique an operator is now able to avoid all the causes of infection due to himself, or the instruments or solutions he employs. One cause only remains of which he is not a complete master—namely, infection of the conjunctival sac, which may produce two kinds of infective complications: first, immediate infection, generally severe and often necessitating the enucleation of the eye; and secondly, late infection, which varies in severity, being sometimes slight, leading to iritis or iridocyclitis, after which complete recovery may take place, or more serious, going on to plastic iridocyclitis which may produce secondary glaucoma or sympathetic ophthalmia. The microbe most commonly responsible is, he maintains, the pneumococcus, although streptococci and staphylococci may occasionally be found. The infection, he thinks, reaches the conjunctival sac from the lacrimal duct. On the afternoon of the same day a series of papers will be read, and Dr. William Wallace will give an epidiascope demonstration of war injuries of the fundus. The Doyne Memorial Lecture will be given on the morning of July 8th by Mr. E. E. Maddox of Bournemouth, whose subject is heterophoria; afterwards papers will be read. In the afternoon demonstrations will be given and operations performed at the Eye Hospital. Papers will be read on the morning of Saturday, July 9th. The members will stay at Keble College from the evening of Wednesday, July 6th, and the annual dinner will take place in the hall of the College on the Thursday evening. A scientific museum will be open during the congress in which various specimens, instruments, and drawings will be shown. There will also be a commercial exhibition.

RECIPROCITY WITH SOUTH AFRICA.

THE President of the General Medical Council, in his address¹ at the opening of the summer session last month, said that the Union of South Africa was desirous that degrees in medicine and surgery granted by the universities in the Union should be recognized as registrable qualifications in this country. The Union, he said, admitted to its *Medical Register* practitioners registered in the United Kingdom. The Executive Committee, to which the Council had delegated its powers in this respect, in view of this fact and in view of the great progress made in the Union in developing its own system of medical education, had had no difficulty in advising the Lord President of the Privy Council that Part II of the Medical Act might be applied in South Africa. An Order in Council was issued last month carrying out this recommendation,

¹ SUPPLEMENT, May 28th, 1921, p. 193.

and the General Medical Council is therefore now free to recognize South African medical degrees which fulfil the prescribed conditions.

CONGRESS OF MEDICAL HISTORY.

THE Congress of Medical History, of which we have already published some particulars, will be opened at the Faculty of Medicine in Paris, by the Minister of Instruction, on the morning of Friday, July 1st. Discussions will take place on that afternoon, and on July 2nd, 4th, 5th, and 6th. The subjects for discussion include the history of hospitals; the diet scale of man, of animals, in antiquity, and in the Middle Ages; great historical epidemics; and the part played by drug dealers in the development of biology. On certain afternoons visits will be paid to various medical institutions and also to the principal libraries, galleries, and museums of Paris. On Friday evening Dr. Henry de Rothschild will give an entertainment at the Gymnase Theatre, when a piece by M. Pascal, entitled "Le Caducée," will be given. There will be other afternoon and evening entertainments, and a banquet at the Palais d'Orsay on the evening of July 6th, when the congress closes.

THE SERUM DIAGNOSIS OF SYPHILIS.

In the report in our issue of June 11th, 1921 (p. 859), of a lecture given by Professor Georges Dreyer, M.D., F.R.S., on June 2nd at St. Mary's Hospital, on a new method for the serum diagnosis of syphilis, the expression "Professor Dreyer's method" was used. We are asked by Professor Dreyer to make it quite clear that the lecture was mainly an account of the joint work of himself and Dr. H. K. Ward, M.C., and the method should therefore be referred to as the Dreyer-Ward method.

As already announced, the gold medal founded by a Fellow of the Royal Society of Medicine for a member of the medical profession who specially distinguished himself during the previous three years, was awarded to Sir Almoth Wright, who gave an address in acknowledgement last November (BRITISH MEDICAL JOURNAL, November 20th, 1920, p. 797). The medal, which was not ready at that date, will be presented to Sir Almoth Wright at the annual meeting of the Society at 5 p.m. on July 6th.

Medical Notes in Parliament.

[FROM OUR PARLIAMENTARY CORRESPONDENT.]

Public Health Officers Bill.

THIS measure, which was introduced in the House of Commons by Sir Philip Magnus, and passed through all its stages there, is now awaiting second reading in the House of Lords. It had formal first reading on June 7th, and since then a petition against it has been presented by the City of Westminster.

Dentists Bill.

The Earl of Onslow, on behalf of the Ministry of Health, moved the second reading of the Dentists Bill in the House of Lords on June 16th. Having explained the provisions, he said that there was only one matter in regard to which there was any material difference of opinion, and that was as to the form of the *Register*. The admission of unqualified practitioners, even on the guarantee of experience required under the bill, had been opposed by Sir Frank Colyer, and a different form of register suggested. He had been answered by the chairman of the Departmental Committee (Mr. Acland) upon the report of which the bill was based. The reasons why the Government stood by the report could be explained in Committee. Lord Greville intimated that, as representing the Ivory Cross Society, he would have some criticism to make in Committee.

The Marquess of Salisbury said he believed all in that House were in favour of the bill, but there was an element which

needed careful scrutiny. In order to arrive at an agreement Mr. Acland's Committee seemed to have been led, as a *quid pro quo* to the unqualified practitioners, to admit the existing ones *en bloc* as fully qualified dentists. That might be good tactics from a parliamentary standpoint, but it was extremely bad for the people who suffered from toothache, and the peers would have to consider closely whether they were going to allow a number of practitioners, some of whom were little better than charlatans, to be admitted by a stroke of the pen to the full advantages, privileges, and dignities of dentists in order to facilitate the passage of the bill. That appeared to be the point. If there were a good answer they would bow to it, but he suggested that the Government should carefully consider whether a change in the bill in this respect ought not to be inserted.

Lord Knutsford said he was a member of the Departmental Committee, which sat for a long time and took a great deal of evidence. There was no suggestion that all unregistered men should be admitted *en bloc* to the *Register*. On the contrary, the Committee limited the admission to those men who had been in good practice for five years and could bring evidence as to good character in their practice. They also recommended that those men who had not been five years in practice, but who would submit themselves to a qualifying examination, should also be admitted. They had also received letters and circulars from a certain number of gentlemen, more noisy than wise, who wished to keep out all the unqualified men from the *Register*. He did not know whether it was realized that by far the greater part of the dental work in this country was done now by these unregistered men, and it would be monstrous to prevent them from carrying on their practice. Moreover, the dental work of the country could not be done unless these unqualified men were allowed to practise. Hence the clause. In those circulars and letters, which their Lordships might have read—or might not have read, but have put in the waste-paper basket for other people to read—there was a suggestion that a special list of these men might be made. A much better way would be that the *Register* should show the qualifications of every dentist opposite his name, and that those who were unregistered, or were on the *Register* without qualifications, should have this fact shown opposite their names in brackets. The Marquess of Salisbury spoke of the privileges of being on the *Register*. There was a good deal more than privilege in it. It meant that the way in which a dentist carried on his profession was controlled; that he was obliged to obey the ethics of the profession; that he could not do this and he could not do that; that he might not canvass and that he might not advertise for work. The *Register*, therefore, was a controlling influence. What they wanted to insist upon was that there should be no unregistered men operating in the country. Those were the huge advantages of the bill, and unless it passed good men would not go into the profession. If this bill passed it would increase the number of qualified men who would join and secure better treatment for everybody.

The bill was read a second time.

Ireland and the Dangerous Drugs Regulations.—Captain Charles Craig, on June 16th, brought before the House of Commons two alleged grievances in the proposed operation of the Dangerous Drugs Regulations as affecting Ireland, and for that purpose formally moved an address to His Majesty to annul the draft. His first point was as to the position of farmers. Hitherto they had been able to keep a small supply of laudanum for dosing horses and cattle for certain complaints, especially for colic. In future they would have to get a prescription from a veterinary surgeon before they could procure any laudanum. He understood that the Home Office was willing to modify the rule so that the drug could be obtained on some sort of certificate to be given by the police or some other body, but he asked for information. The second point concerned the chemists and druggists of Ireland. Under the law pharmaceutical chemists in that country had a monopoly of dealing with prescriptions, and ordinary chemists and druggists were able to sell poisons of any kind, though not to compound prescriptions. Under the Regulations the drugs specifically mentioned in the Act could be served out only on prescriptions, which meant that the chemists and druggists would lose their rights. It was hard that because of a certain amount of drug-taking in large cities these traders should lose a considerable part of their business. He put it that the same kind of certificate proposed for farmers should be available for them—for the sale of laudanum for instance—and that they should be at liberty similarly to sell patent medicines, such as chlorodyne and zinc ointment, which, he gathered, contained a prohibited drug, and other things which they received from manufacturers. Sir John Baird (Under Secretary for the Home Office) said it was certainly necessary to meet the case of the farmers. The Committee had suggested that this could be done in one of two ways—either by selling laudanum in a denatured form, or else, pending the discovery of some method of denaturing laudanum, by certificates issued to farmers by the local police. It was intended to provide for such issue. In the case of the chemists and druggists such legal opinion as the Home Office had been able to take held that, though the chemists and druggists were prohibited from compounding mixtures, they were entitled to dispense made-up prescriptions of something they had not made up themselves. Moreover, there was a considerable list of drugs which were exempted. Taking these two things together—the exempted drugs as contained in Schedule 2 and the belief that the druggist would be entitled to dispense mixtures containing poisons

which he had not himself compounded—*Le Doped* that the position was met. On a further question Sir John Parnall said, as regards the farmers, that the police authorities would not have to state whether a man was entitled to have land in. The certificate to be granted by the police authorities would be on a form supplied by the Home Office, and would be to the effect that the man was a bona fide farmer or stock owner. That was a matter of fact, not of opinion. Captain Craig afterwards withdrew his motion.

The Appointment of Medical Referees.—Mr. J. Guest asked the Minister of Pensions, on June 16th, (1) whether, since the original appointments of medical referees were made before the completion of medical demobilization, these appointments would now again be declared vacant and re-advertised, or whether the original appointments were fixed and permanent appointments of the present holders; (2) whether the appointments of medical referees were now reviewed every six months as originally decided; how many of these appointments have been considered vacant on review and changed, and whether the opinion of the local pensions committee is ever asked or considered in these appointments. Mr. Macpherson replied that in the latter part of 1919, when the demobilization of medical men was practically complete, the then existing appointments of medical referees to the number of 962 were declared and 1,553 new appointments were made, preference being given to those men who had served overseas during the war. All the present appointments were temporary, being subject to one month's notice on either side. While the paramount consideration in making these appointments must be medical, consideration was always given to representations made by local committees. In answer to Mr. Guest, Mr. Macpherson said that the Ministry utilized the services of 1,717 medical referees, whose appointments were part-time and subject to a month's notice. Payment was made at the rate of 5s. per case, except where the examination was in connexion with a claim to alternative pension, when the fee was 10s. 6d. The amount paid in fees to medical referees during the last financial year was approximately £2,500. He did not think there had been a transfer of duties formerly performed by war pensions committees to the medical referees. They dealt purely with the medical aspect of a case, and the local pensions committees dealt mainly with the facts.

Criminal Law Amendment Bill.—Viscountess Astor asked Mr. Chamberlain, on June 15th, whether he had received copies of two resolutions passed at a meeting held in the House of Commons in support of the Bishop of London's Criminal Law Amendment Bill, at which practically every organization interested was represented, promising to abstain from introducing controversial amendments, and whether, in the circumstances, he would give facilities for the passage of the bill this session. Mr. Chamberlain said he had received the resolutions, but could not make a pledge to find time at this stage, though he hoped it might be possible to do so later. Viscountess Astor again pleaded for a definite assurance, remarking that the measure would not involve any expenditure and was one of the bills that the Government could get through. Mr. Chamberlain said that he quite understood the importance attached to it by a very large section of public opinion, and he was anxious that it should be considered by the House this session. Major Claud Lowther asked whether Mr. Chamberlain was aware that the bill was likely to lead to considerable controversy. Viscountess Astor: Only by a certain section.

Scottish Universities.—Mr. Munro announced, at the instance of Mr. McCallum Scott, the decision that the annual financial and statistical reports relating to Scottish Universities for 1919-20 and future years, will be made available for members of the House of Commons in the form in which they appear in the returns from universities issued by the University Grants Committee.

National Health Insurance.—Mr. Jack Jones asked, on June 15th, if the Minister of Health would consider, in view of the large amount of unemployment and consequent distress, the advisability of making an allowance in contributions, under the National Health Insurance Act, so as to prevent a reduction in benefits to those who were drawing allowances under the Act. Sir A. Mond replied that the matter was being seriously considered, in the hope that it might be possible to do something in the direction suggested.

Medical Benefit.—Mr. Lyle, on June 20th, asked if there were statistics showing the number of insured under the National Insurance Act who were already in arrears with the maximum total of unpaid subscriptions, which, unless met before October, would debar them from medical benefit in 1922. Sir A. Mond replied that all insured persons remained entitled to medical benefit so long as they continued in insurance, and there was no suspension of benefit on account of arrears of contribution.

Holloway Prison.—Mr. Shortt, in reply to Lieut. Commander Kenworthy, on June 14th, said that no complaint as to the condition of the food served to prisoners in Holloway Prison had been made to the Visiting Committee. Members of the Committee frequently tested the quality of the food and were satisfied with it. Individual prisoners sometimes complained, but otherwise there was nothing to support the suggestion. No complaint had been made of the milk being sour. Mr. Shortt also answered in the negative the question as to the abolition of the hospital.

Medical Officers and Inspectors of Prisons.—Mr. Alfred T. Davies asked, on June 15th, what proportion of medical men whose services were used for examining ex-service men, had had experience overseas during the war, and whether the Minister of Pensions would consider the desirability of employing a larger number of such medical men in the interests of those so examined from time to time. Major Tremen said that approximately 60 per cent. of the medical officers employed in the department in examining ex-service men had served overseas during the great war. It was the practice of the Ministry, other things being equal, to give preference to medical men possessing the qualification named.

Income Tax Assessment.—In Committee on the Finance Bill, on June 14th, Mr. Hughes moved an amendment to Clause 18, under which Parliament is asked to say that Sections 43 and 44 of the Income Tax Act of 1918 were not continued in force for the year 1920-21, and are now expressly repealed. Under Section 43 of the Act of 1918, any person or company whose profits were reduced from war circumstances could claim to be charged on the average of three years ending the year of assessment instead of on the average of the previous three years. Under Section 44, any individual proving that his actual income from all sources was less by 10 per cent. than the income on which he had been assessed on the three years' average, was entitled to be charged upon his actual income and to obtain repayment of the difference. Last year Mr. Holmes moved specifically that these sections of the 1918 Act should remain in force. This was defeated at the instance of the Government by a large majority. But it seems to have been left obscure whether in the absence of a definite repealing provision the sections do not remain in force. Sir Robert Horne stated that there had been six decisions by Commissioners, three one way and three another, and none had gone to a court of law. Five hundred claims were pending. In the course of the debate there were protests, more especially against the retrospective part of Sir Robert Horne's proposal, but it was carried by 205 votes to 31.

Reassessment of Pensions.—Lieut.-Colonel the Hon. G. F. Stanley informed Mr. Frederick Thomson that, in the case of both officers and other ranks serving during the late war with a force under the British flag, service should count for reassessment of pension as if the service had been rendered with the British forces.

Deaths Associated with Vaccination.—In answer to Mr. J. Davison, Sir A. Mond stated that according to the Registrar-General's returns, the deaths registered in England and Wales in each of the last ten years as caused by or associated with vaccination are as follows:

	Registered on Certificate of a Registered Medical Practitioner.	Registered on Coroner's Certificate after Inquest.	Uncertified.	Total.
1911	11	4	—	15
1912	6	4	—	10
1913	6	—	1	7
1914	1	4	—	5
1915	9	1	—	10
1916	2	1	—	3
1917	6	2	—	8
1918	4	—	—	4
1919	5	2	—	7
1920	15	4	—	19

It cannot, however, be stated whether any of the cases in which no inquest was held were reported to a coroner or not.

Outbreaks of Rabies.—Major Barnston informed Captain Sir Hamilton Benn, on June 14th, that the most recent outbreak of rabies in England occurred at Southampton on June 6th and at Salisbury on June 7th. There had been no recent outbreak of rabies in Scotland. In Wales the last outbreak was on September 8th, 1920. As regards Wales the Muzzling Order was withdrawn on May 1st, 1921.

Wholesale and Retail Milk Prices.—Sir A. Boscawen said that the average prices at which contracts had been made for the summer months for milk delivered into London, producer paying carriage, were as follows: May and June, 1s. 2d. to 1s. 3d. per gallon; July, 1s. 4d. to 1s. 6d.; August, 1s. 6d. to 1s. 8d.; and September, 1s. 8d. to 1s. 10d. He understood that the price at which milk was being retailed in London was usually 8d. a quart. On another question, by Mr. Hurd, the Ministers said he was unaware that in some districts in Somerset farmers were receiving from wholesalers more than 10d., 8d., and in some exceptional cases, 6d. per gallon for their milk.

The River Lee.—Major Malone, on June 16th, asked the Minister of Health if he would exercise such pressure on the Lee Conservancy Board as to compel that authority to purify the river. He said that as late as last week the medical officer for Tottenham had reported to his Committee that objectionable matter, consisting of decomposing organic material and oil substances, had entered the river below the Tottenham Lock, causing, that reach to be highly polluted and offensive. Sir A. Mond replied that he had no information as to the complaints referred to, and he had no power to compel the Board to carry out the work indicated.

For-Save Men in Asylums.—Mr. F. Roberts asked, on June 16th, whether when an ex-service man had been committed to an asylum on account of mental injury attributable to the war, the man himself and his next of kin were informed that one of the privileges attached to his having been placed on a private patient footing was that, provided that he could not be proved to be dangerous and unfit to be at large, his next of kin had the right, in accordance with Section 72 to 74 of the Lunacy Act, to direct his discharge. Sir Alfred Mond said it was not desirable to furnish this information on admission, but when a service patient was sufficiently recovered to raise the question of his discharge, he was informed of the legal position and of the steps to be taken by his relatives.

England and Wales.

THE WEST MIDDLESEX HOSPITAL.

THE West Middlesex Hospital, situated at Isleworth, was formerly known as the Brentford Union Infirmary. It is built on an extensive site, which includes also the buildings of the workhouse, separate blocks for pulmonary tuberculosis, midwifery, and mentally defective boys. The wards of the hospital are of modern construction, well lighted and ventilated, and diverge from each side of a long central corridor. The wards on one side of this corridor contain 14 beds; on the other side are larger wards of 24 beds. There are three stories to each block. The total number of beds in the hospital is 420, but at present not all of these are available for patients. The number of beds in the workhouse is 880. Recently more of these have been made available for chronic patients and slight cases from the hospital; the total number of patients in the workhouse under the care of the medical staff of the hospital is now about 500.

Although it is now described as the West Middlesex Hospital the institution remains under the guardians of the poor of the Brentford Union. There is an arrangement by which the County Council sends its patients to the tuberculosis block, which has been raised off from the rest of the building. But this block, like the rest of the hospital, is under the governance of the guardians. The medical staff consists of a superintendent and two assistants. There is also a consultant staff, drawn mainly from London, whose services are honorary so far as the Poor Law patients are concerned: but they are paid the sum of one guinea as travelling expenses for each attendance.

The patients consist of Poor Law patients who are considered to be destitute and have to pass through the hands of the relieving officer. But the Ministry of Health allows considerable latitude in the estimation of medical destitution. Consequently many of the patients are by no means destitute, from the financial point of view. They are admitted because their means do not permit them to obtain suitable treatment; and those who can afford to pay are charged up to a maximum of £3 5s. a week for maintenance. Recently it has been decided to set apart two wards of eight beds each for a better class of paying patient. These patients will pay four guineas a week for their maintenance, with extra charges on a fixed scale for special services of a consultant or specialist nature, such as consultations, operations, x-ray work, and so on. The paying patients will only be admitted on the recommendation of an outside practitioner; they will be admitted through the clerk to the guardians, and not through the relieving officer; and it is intended that only serious cases, medical or surgical, shall be accepted for admission. Further, it is hoped to institute something of an out-patient nature, at all events for special cases. These paying patients will be treated by the medical superintendent and his assistants, but will have available the services of the consultant staff at the tariff which has been laid down.

In this brief description it will be seen that the arrangements at the West Middlesex Hospital differ in essential points from the ideals aimed at in Bradford; for example, the only attempt at disguising the nature of the institution has been the change of name. The guardians of the poor are the authority responsible for the institution. Except in case of emergency, the patients pass through the hands of the relieving officer. The hospital is not a municipal hospital open to all ratepayers. Inability to pay more than a certain rate for maintenance remains a safeguard against

misuse. With regard to the paying patients, however, the criterion for admission is not so much financial disability as the severity of the condition of sickness or disease. If the patient is sufficiently ill, or requires operation, he will be admitted, provided that his doctor recommends him and the clerk to the guardians is satisfied that he cannot afford to pay specialists' and nursing home fees. The decision as to admission rests with the authorities of the hospital; financial limitation being contemplated to a certain extent, inasmuch as the fees payable for consultant or specialist assistance are on quite a low scale.

The arrangements at this hospital do not seem to be in accord with the expressed opinions of the British Medical Association. The general practitioner is not used in any way except as a safeguard in the admission of patients to the paying wards. The treatment of the patient passes entirely into the hands of the hospital staff, and it is, we understand, considered impossible to make arrangements that patients admitted to the paying wards shall be treated by their own family practitioners. The hospital is not in any sense a primary centre such as is described in the Dawson Report.

There seems little doubt that the hospital, as at present conducted, meets some of the needs of the community. It provides hospital facilities for those who cannot afford to pay the ordinary fees of surgeons and of nursing homes. The facilities provided include nearly all those things which are said to be lacking in the treatment of pauper patients and the poorer classes of the community. Both with regard to Poor Law patients and those who will become paying patients in the hospital it imposes limits to prevent abuse by those who can afford to pay. It safeguards the general practitioner by refusing admission to the paying wards except on his recommendation. There are certain other points which should be carefully considered by the medical profession. In the first place the question arises whether the facilities provided at the public expense should be limited to certain sections of the community. At the present time the necessity of limiting expenditure probably renders such limitations obligatory. Should they be maintained when the financial position of the local authority improves? Much has been said about the abolition of the stigma of pauperism. But so long as a distinction of classes is made into those who can afford to pay for their treatment and those who cannot, so long there is bound to remain a stigma, at all events of poverty. The distinction involves the retention of an official of the nature of a relieving officer. He may be glorified by the name of almoner, but in essence his duties will in this respect be the same.

Secondly, so long as the distinction of classes is maintained, are the safeguards to the general practitioner sufficient? On the one hand, the relieving officer should be an efficient check in preventing abuse of the Poor Law side of the institution; on the other hand, the requirement of a doctor's recommendation should prevent the use of the paying wards by persons able to pay full fees and charges. The requirement that the clerk to the guardians shall approve the recommendation will tend to relieve the general practitioner of the risk of incurring odium by refusing to recommend unsuitable patients. The working of these safeguards is likely to be more satisfactory if the local profession is represented by a strong medical committee acting in harmony with the hospital authorities, and ready to judge any hospital scheme by the criterion whether it will work in the long run for the good of the community. This leads to a third question, which is, whether attendance by general practitioners will prove to be feasible in hospitals which serve large populous areas. So far as indication of their opinion has hitherto been given, the great majority of public medical officials regard such an arrangement as impossible. In cottage hospitals it can be made to work. In primary health centres, provided they serve a small area, it is possible that every local practitioner will be able to attend his patients in the hospital, though even here difficulties may arise. In large hospitals of the infirmary type it is not so easy to see how the difficulties would be overcome, and anything which helps us to understand how they may be surmounted is of value. The study of systems such as exist or are proposed in institutions of the nature of Bradford Municipal Hospital and the West Middlesex Hospital should help to elucidate these questions.

Scotland.

PARLIAMENTARY REPRESENTATION OF SCOTTISH UNIVERSITIES.

At meetings of the Unionist Associations of the Scottish Universities held recently a letter was received from Sir Watson Cheyne, Bt., K.C.M.G., one of the members for the Universities, stating that he might be compelled on account of his health to resign at any moment, and that even if he were able to remain in office till the end of the present Parliament he had definitely decided not to seek re-election. He suggested that a suitable prospective candidate should be selected without delay, so that he, Sir Watson Cheyne, might be in a position, if he felt unable to go on any longer, to resign without feeling that he was doing anything harmful to the constituency. It was unanimously agreed that in view of the complex problems of public health with which the House of Commons has now to deal, and of the value in relation thereto of highly trained professional opinion, the services of an eminent medical graduate of one of the Scottish Universities should if possible be obtained. Sir George Andreas Berry, LL.D., F.R.S.E., a former President of the Royal College of Surgeons, Edinburgh, and of the Ophthalmological Society of the United Kingdom, has been invited to become prospective Unionist candidate, and he has agreed to place his services at the disposal of the constituency. Sir George, who was educated at Marlborough and Edinburgh University, and also studied in London, Paris, Copenhagen, Vienna, and Giessen, was from 1882 to 1905 ophthalmic surgeon to the Edinburgh Royal Infirmary, later he acted as one of the managers; and for the past ten years he has been a member of the University Court of the University of Edinburgh. During the war, and for one year after the war, he served as Chief of the Ophthalmic Department of the 2nd General Hospital, in which capacity he had sometimes to deal with 100 new cases a day. He was knighted in 1916 in recognition of his scientific work. Lady Berry is a daughter of the late Sir William Muir, K.C.S.I., for many years Vice-Chancellor and Principal of the University of Edinburgh.

EDINBURGH UNIVERSITY COURT.

At a meeting of the Edinburgh University Court, on June 13th, Professor Sir Robert Philip and Professor Ritchie were appointed representatives of the University to the International Conference on Tuberculosis to be held in London in July. The Court resolved, consequent on the approval of the ordinance concerning matriculation and graduation fees, that on and after September 1st, 1921, the matriculation fee payable at the beginning of each academic year should be two guineas instead of one guinea; the fees for the degrees of Bachelor of Medicine and Bachelor of Surgery are to be £34 13s., for the degree of Master of Surgery £21, and for the degree of Doctor of Medicine £21. As recorded in another column, the resignation was intimated, and received by the Court with great regret, of Professor Sir John Halliday Croom from the chair of midwifery, and the gift by the professor of all the preparations, specimens, apparatus, and diagrams collected during his tenure of the chair, was accepted with thanks. The Court accepted also the offer of the Associated Societies of the University to present the records of the Hunterian Medical Society, formerly one of the Associated Societies, but now defunct for many years, and directed that the records should be deposited in the University library. It was reported to the Court that Lord Lytton and other members of the Committee on Indian Students appointed by the India Office would visit Edinburgh University on Monday, June 27th, and successive days. The Court resolved to invite all the Indian students and graduates of the University resident in Edinburgh to meet the committee in the Old College on June 27th. at 4 p.m.

CARE OF THE BLIND.

The Scottish Board of Health has issued a circular to local authorities with regard to the Blind Persons Act, 1920, drawing attention to the desirability of making proper use of the existing facilities and of assisting voluntary effort. At present, it is pointed out, grants are payable to approved voluntary agencies in accordance with the regulations made by the Board in respect of such services

as workshops and homes for the blind, hostels, home teaching, and book production. Application may, however, also be made by a voluntary agency for a grant in aid of any scheme of assistance other than those referred to in the regulations, which has for its object the betterment of the conditions of the blind or the prevention of blindness.

Ireland.

IRISH MEDICAL ASSOCIATION.

The annual general meeting of the Irish Medical Association was held in Dublin on June 15th, Dr. E. Magennis presiding. The statement of accounts showed a surplus of £854, and the membership at the end of the year was 684. The annual report and financial statement were adopted. Dr. Magennis was re-elected president, and in acknowledging the honour said that it had been suggested that the constitution of the Association should be altered, as the present system had not been a success; it was also proposed that the present subscription be increased. Dr. W. O'Sullivan was re-elected vice-president.

ROYAL MEDICAL BENEVOLENT FUND SOCIETY.

The annual meeting of the Royal Medical Benevolent Fund Society of Ireland was held in Dublin on June 15th at the Royal College of Physicians, with Sir James Craig in the chair. The annual report was read by Sir John Moore. The amount given in grants during the year was £1,201, and the revenue from all sources was £2,915. The President said that it was a serious reproach to the members of the medical profession that they did not realize the urgent need of supporting the Benevolent Fund Society.

ROYAL VICTORIA HOSPITAL, BELFAST.

At the meeting of the Board of Management of the Royal Victoria Hospital, Belfast, held on June 15th, S. B. Boyd Campbell, M.D., F.R.C.P. Edin., was appointed assistant physician, in the place of Dr. J. E. MacIlwaine, lately appointed physician.

Correspondence.

TREATMENT OF ACUTE TOXAEMIA.

SIR,—In his letter on this subject to the JOURNAL of June 4th Sir Archdall Reid states clearly a strong prima facie case for his belief that it is possible, by artificial means, to abstract toxin from sufferers under acute febrile diseases, and appeals to all ranks of the profession to make a trial of the treatment he has employed with a view to testing its value. Among the diseases mentioned by him as suitable for this trial are acute lobar pneumonia, diphtheria, measles, puerperal fever, sepsis, small-pox, etc., and the treatment he advocates is the giving, as early as possible, a dose of aspirin (10 grains), phenacetin (5 grains), and pulv. ipecac. co. (5 grains), to be repeated once or twice in twenty-four hours till the symptoms cease to recur. Unable as I am to make any such trial myself, but being sufficiently convinced of the importance of testing the results of Sir A. Reid's considerable experience in the matter, I ask for space for the following few remarks:

It seems essential (1) that the selected cases for testing should be in the earliest stage possible for observation, so as to lessen the likelihood of natural recovery at the recognized average periods; (2) that a careful diagnosis be made, and the symptoms, signs, and course of each case accurately recorded; (3) that every possible means be taken for careful examination of the sweat for the purpose of discovering the presence or absence of toxins.

Sir Archdall's hypothesis is based to some extent on the widespread belief that the sweating which occurs, whether in the so-called "critical" or continuous form, in many acute fevers is a natural method of cooling the healthy body; but this hypothesis also requires the assumption that elimination of toxins accompanies the sweating which so soon follows on the administration of each dose of the drug in febrile cases.

Lastly, though this point is perhaps not essential, I would remark that the exact nature of the drugs employed by Sir Archdall Reid may possibly escape the notice of

some who will make trial of this treatment. Some practitioners who object to phenacetin may prefer to give 15 grains of aspirin, and leave out the phenacetin; and some may question the importance of giving the compound ipecacuanha powder. Many may be inclined to attribute the rapid fall of temperature, abolition of headache, and sweating to the aspirin, and to give aspirin alone. I mention this as it seems desirable, in an extended trial of this great importance, that the medicine and doses used should be uniform throughout, and that, at least in the early trials for the purpose of testing the value of the treatment, Sir A. Reid's formula should be strictly followed. If the test corroborates his results, it would be of course open to anyone to modify the composition of the medicine employed.

There is an ample field for this testing in fever hospitals and especially in general practice.—I am, etc.,
London, W., June 19th. H. BRYAN DONKIN.

WHAT IS SCIENCE?

SIR,—In your issue of June 4th, in a very able and interesting leader on Medicine a Science, in which you do me the honour of mentioning my name, you have discussed various definitions of the word *science*. You quote specifically Sir William Osler's dictum that "the goal of science is the acquisition of new powers by new discoveries," and that of Clifford, recalled by Sir E. Ray Lankester, that "the subject of science is the human universe; that is to say, everything that is, or has been, or may be, related to man." You dismiss—rightly in my opinion—both these descriptions as not entirely satisfactory.

Now, I am far from being prepared to give a definition of science; still less am I in a position to correct or amend the definitions given by the very distinguished men whom you have quoted. Yet, without attempting to define science, may I suggest a provisional test for what is a science—a test that has been helpful to me, and, I think, may perhaps be of service to others? It is a test that I have ventured to apply tentatively in a chapter on "Science" contributed to a recent book on *Mediaeval Contributions to Modern Civilization*, edited by Professor F. J. C. Hearnshaw.

The test I apply is that *science is knowledge in the making*. We are all in danger of considering that science is a particular kind of knowledge, but reflection shows that it is not so. A Greek text, for example, may be scientifically treated and the scientist (called a philologist) may apply a perfectly scientific method in restoring or correcting it. Again, chemical knowledge can be quite unscientifically treated, as a glance at an advertisement of a quack remedy may rapidly convince us. The corrected text, however, can hardly be said to give "new powers" (to use Sir William Osler's phrase) in the ordinary sense of the word "power." Yet it is clearly knowledge in the making, and the text may be said to be scientifically edited.

Apply this test for a moment to medical studies, and let us take, as an example, the simplest and most fundamental of those studies. Descriptive human anatomy was, in the main, a creation of the sixteenth and seventeenth centuries. In the hands of Leonardo and Vesalius, of Fallopius, Fabricius ab Aquapendente and Eustachius, it was a progressive science. During the eighteenth and nineteenth centuries the limit of that type of knowledge was nearly reached. Descriptive anatomy is now a valuable and indispensable *discipline*, but it has almost as much ceased to be a science as has the equally indispensable knowledge of the multiplication table. Descriptive anatomy is hardly any longer knowledge in the making. Of course anatomists still retain their position as men of science—there are probably none with a better right to that title—but they do so mainly by virtue of the excursions they make into kindred and still progressive studies, such, for instance, as comparative anatomy, embryology, ethnology, physiological mechanics, and the like.

Apply the same test to the knowledge of a language. The grammar and construction of the classical and of the Western European languages are a fully explored field. The learning of them is a discipline; science has no part here. But there are still progressive sciences of phonetics and of comparative grammar. When the unwritten language of some wild tribe is from time to time explored, the process is or should be an application of scientific

method, and that method is still applicable to the imperfectly known languages of the monuments of the ancient East.

Science in this view is inextricably wrapped up with research; it is the growing edge between the unknown and the known, between the desert and the sown. In places this edge is sharp and clear, in places there is a wider and debatable area.

But there is a corollary arising out of this view of science as a process. To understand a process it is inevitably necessary to understand how it came to be what it is. A process is an organic thing—to understand it you must know and understand its history. Thus the teaching of science becomes, in its ultimate analysis, instruction in history; not, of course, what is usually termed "history" by the professed historians, nor even by the historians of science, but history, nevertheless. The "heuristic" method of teaching science—the only method that teaches science proper, the art of discovery, as distinct from the results of science—is in reality a method of recognizing this. You can only explain "scientific knowledge" by explaining *why* you hold that knowledge to be true knowledge. The answer to this question Why? must in its nature be a verification of past experience by present evidence, and this is, in fact, the method of history.

Thus we see the wheel turn full circle. The methods and the manner of teaching of the science of medicine that are so eloquently preached by Sir James Mackenzie are not far removed from the line of advance of what are too narrowly termed the "humanities." For the truth is that knowledge is one, and there is only one true and safe method of advancing it, and that is science. It is sometimes pathetic to see so-called "specialization" in scientific knowledge tending to separate men's thoughts and spheres of work rather than to unite them. This separation, however, mentally destructive though it be, can only be a passing phase, and is, perhaps, already declining. It is an evil against which the life work of the great men you have quoted—Osler and Clifford, Lankester and Mackenzie—stands out in lasting protest.—I am, etc.,

Oxford, June 15th.

CHARLES SINGER.

CAPILLARY PRESSURE.

SIR,—Dr. Gillespie (June 11th, p. 873) compares the capillaries to a soap bubble, and imagines the capillary wall as exerting a surface tension which raises the internal pressure. Now in the amputated leg of a frog the capillaries of the web of the foot are not emptied. Many remain full. It is evident, then, that the capillary wall does not exert a surface tension comparable to that of a soap bubble. The same thing holds good for the capillaries of the arm. Let the circulation be stopped by a tourniquet, after emptying the big veins by raising the arm for a second or two; the skin only slowly blanches, and the blanching that does take place seems to be brought about by gravity or bringing in the compressive action of the muscles. Again, in the case of the brain: when the skull is trephined and the dura incised the brain bulges in the trephine hole, but collapses when the heart stops beating and gravity comes into play. It does not collapse if the animal be so tilted that gravity keeps the vessels full. The surface tension energy imagined by Dr. Gillespie should certainly empty the capillaries against a very moderate opposing force of gravity.

If the brain ceases to bulge into the trephine hole when the heart stops beating, and the animal is in the horizontal position, it is just to infer that the expansion of the brain is due to that part of the force of the heart-beat which is left over after overcoming the resistance in the arteries and arterioles and maintaining the kinetic energy of flow, and the pressure that is required to reduce the bulging of the brain into the trephine hole is then the pressure that is required to overcome the expansion of the arteriole, capillary and venous network. That pressure is the same within the limits of measurement as the venous pressure measured directly in the torcular Herophili, and the same as that of the cerebro-spinal fluid measured by passing a hollow needle through the occipital atlantal membrane.

The method which I have used for measuring capillary pressure is one contrived by Roy and Graham Brown, and is one which has been used by many other physiologists. My findings are supported by Basle, who, after cutting

the finger and inserting it into a suitable vessel, measured the pressure to which the escaping blood raised the manometer—that is to say, he measured the internal pressure and found results which agree closely with those obtained by me using the Roy and Graham Brown apparatus.

In the amputated leg of the frog a very slight alteration of external pressure sends the corpuscles swirling along the capillary vessels. When the blood is flowing naturally a very small external pressure suffices to stop the flow in the outlying capillaries at the external edge of the web, the flow taking the pathway of less resistance through wider networks.

Physiological experiment has shown that an artery, big or small, when compressed by a surrounding fluid pressure, is shut up by a compressive force practically equal to that of the pressure which is maintaining the flow through the artery, and which is measured directly by a manometer connected with the lumen of the artery. The same holds good for a vein, big or small. It holds good also for the excised kidney when Ringer's fluid is circulated through it and the whole organ is submitted to external compression. It is known that a pressure of 10 to 15 mm. Hg suffices to maintain a circulation through the kidney. If the capillaries of the kidney were striving to contract like a soap bubble owing to surface tension, they ought to resist the flow of fluid at such low pressure.

The capillaries open into the veins, and measurement shows that venous pressure is very low, and in close agreement with the measurements of capillary pressure made by me. It seems highly improbable that there should be a high internal pressure produced by surface tension inside capillaries and a very low pressure in the veins with which they closely communicate. All these facts seem to show that we have the right to assume that the Roy and Graham Brown method holds good for the capillary sized vessels.

These statements are founded on physiological experiment, and if erroneous they can be overthrown by further experiment and more exact measurement. Physical theory unaccompanied by such experiment will do nothing to elucidate the principles of capillary circulation.—I am, etc.,

London, N.W.3, June 14th.

LEONARD HILL.

SIR,—The application of even elementary facts in physics to physiological data presents more difficulty than is apparent at first sight. It is apt to be forgotten that the physicist, especially in his mathematical treatment of experimental data, simplifies his data as far as possible. He introduces into his argument certain postulates, but prefers not to have too many postulates to deal with. The physiologist, on the other hand, can advance only slowly because he can neglect no data whatsoever pertaining to his problem.

To illustrate: Dr. Gillespie, in his interesting letter, sees an analogy between the mechanism which maintains a soap-bubble wall under tension and the mechanism by means of which a capillary wall, though thin and flaccid, could withstand high capillary pressure. Now, in the case of a soap bubble the pressure distending it is created by the tendency of the walls—surface tension—to contract into smallest compass, and, as elementary books on physics state, the pressure inside a soap bubble decreases as the bubble gets larger. Consequently, considering the very small radius of a capillary, it could withstand high internal pressure. After all, states Dr. Gillespie, the tension of the wall would be very small.

Now the physiologist may enter the field and ask whether the walls of a capillary actually behave like a soap-bubble film. If the pressure inside a soap bubble could be suddenly diminished below atmospheric the bubble walls would collapse. If, similarly, the pressure inside a capillary is reduced to zero we do not find that the walls of the capillary suddenly collapse. When the large veins are emptied by raising the arm for a few seconds and the brachial artery stopped by a tourniquet it takes quite a considerable time for the skin to become blanched, and even in this the blanching is aided by gravity. Evidently, then, there is no analogy between the tension of the wall of the soap bubble and the physical state of the wall of a capillary full of blood.

But I am quite willing to be aided by the simple formula used by Dr. Gillespie. I shall now proceed to apply it.

Let p_1 = represent inside pressure—for example, pressure inside capillary.
 p_2 = represent outside pressure—for example, pressure outside capillary.

Now, states Dr. Gillespie,

Let $p_1 - p_2 =$ the pressure caused by 50 mm. of Hg.

Here, again, the physiologist must interrupt the physicist. Where is that 50 mm. of Hg obtained? There is an airiness about that postulate of quite an engaging nature. The trouble is that no data whatever are available to the physiologist until he first measures p_1 plus p_2 —the pressure inside the capillary and the pressure outside the capillary.

Now the point arises whether the pressure outside the capillary can be compared with the pressure in a soap bubble. The skin is elastic and is distended by the inhibition of the tissues. Wounds we know gape. The skin then exerts a force inwards. It, like the soap bubble film, struggles to contract itself into smaller compass. According to the latter part of Dr. Gillespie's argument, we shall not need so much pressure to blanch capillaries, because the skin is compressing them. Now we find that $p_1 + p_2$ may amount to 33 mm. of Hg, where the measurement is made at heart level on the skin of the last digit of the thumb.

But p_2 can be measured—that is, the pressure required to collapse the flaccid capillary wall—when we have reduced the capillary blood pressure to zero and then found the pressure required to blanch them. According to Dr. Gillespie, that should not require much pressure, for the distended capillary wall under tension is striving to collapse and the outside skin is striving to contract. A small pressure, much less than the internal tissue pressure, is sufficient, according to Dr. Gillespie, to narrow the capillary walls and squeeze the blood out. We find that the pressure required to blanch the same last digit of the thumb at heart level is 23 mm. of Hg.

Now $p_1 + p_2 = 33$ mm. of Hg,
 $p_2 = 23$ mm. of Hg.

Accordingly $p_1 = 10$ mm. of Hg
 and $p_1 - p_2 = -10$ mm. of Hg approximately,

following Dr. Gillespie,

$T = \frac{1}{2} \times 15.6$ grams per sq. cm.
 $= 7.8$ grams per sq. cm.

Then $-15.6 = \frac{0.000005 \times T}{r}$
 and $T = 0.00005$ gram per cm. of length.

It will be noted that when physiology enters the field and supplies actual measurements in place of a gross assumption of 50 mm. of Hg, as the value of $p_1 - p_2$, Dr. Gillespie's application of simple physical law shows the tension per unit of length tending to split the tube longitudinally is actually a minus quantity. Is not this the result to be expected? No such tension exists.

The fact is, Dr. Hill is as nearly correct as any man of equal eminence who has devoted a large measure of his life to the study of these difficult problems can hope to be in the present state of our knowledge. The capillary wall is, to use Dr. Gillespie's phrase, "so thin and collapsible"; the venous wall is thicker but collapsible. The moment you compress and diminish the calibre of a vein by outside pressure, you measure the internal pressure. Similarly in a capillary, but with this fundamental physiological difficulty before you, in both cases—if you constrict the wall even slightly, the pressure you measure is no longer capillary but mounts automatically to the higher arteriole pressure of the entering blood stream.

There is no evidence whatever that the capillary wall is under strain like the film of a soap bubble. If you block by compression a capillary by stopping a red corpuscle, you have overtopped the internal capillary pressure without any assistance whatever from the flaccid capillary wall.

Finally, in the case of the measurement of arterial blood pressure it has been found that stoppage of the pulse wave accurately measures the systolic pressure and gives practically the same reading as a manometer connected directly with the artery. The blood flow stops at a pressure of at most a few millimetres of Hg higher.

Now the arterial wall is under distension, and to this extent may be compared to a soap-bubble film. It exerts

pressure tending to narrow the artery. But we have to exert a pressure equal to the internal pressure and no less to stop the pulse wave when the armet is used on the upper arm.—I am, etc.,

Halesowen, June 10th.

JAMES M. McQUEEN.

HEART-BLOCK.

SIR,—In your issue of June 11th Dr. G. Arbour Stephens makes some criticisms on my paper on heart-block which appeared in the *JOURNAL* of June 4th. Especially he calls in question my justification for the statement "it is clear that the systolic plateau is dimpled by the drag of the contracting auricle," and in connexion with this he asks "Is it the function of the auricle to 'dimple,' and if not, why in this particular case?"

I think it is generally recognized that when the auricle contracts at its usual time, that is to say, immediately before the ventricle, it will drive blood into that cavity, and cause its apex to rise against the chest wall to such an extent that in many cases, though not in all, this may be demonstrated in a tracing taken from the apex beat. It has been explained to us, and by no one better than by Sir Arthur Keith, that the auricles not only drive blood into the ventricles, but pull the bases of the ventricles upwards and backwards over the volume of blood in the auricles, and he happily likens this double action to that of a man pulling on a boot; for not only does he push his foot into the boot, but he pulls the boot up over his foot. Now, when the left auricle contracts, as it normally does at a time when the ventricle is at rest, its pull at the base in a direction away from the apex of the heart is more than neutralized in many instances by the projection of blood into the cavity of the ventricle, whose apex therefore is caused to rise, as may be shown in a tracing. When, however, the auricle contracts at the same time as the ventricle, there is probably no passage of blood into the lower chamber, and there will be no such wave as I have described. On the other hand, the auricle will, by its contraction, draw back the base of the ventricle in the manner described by Keith, and this will result in a dimpling of the systolic plateau.

It may be asked, "If the auricle cannot drive its blood onwards when it contracts at the same time as the ventricle, what becomes of that blood?" I suppose the answer to this is that it is driven back to some extent into the pulmonary veins, in the same way as we know from jugular tracings that the right auricle drives blood back into the veins of the neck when it finds itself contracting at the same time as the ventricle in some varieties of extrasystole, and in certain cases of spasmodic tachycardia. It is only therefore, I repeat, when the auricle and ventricle are contracting synchronously, and especially when the auricular systole falls near the middle of that of the ventricle, that we should expect to find this dimpling. It is seen in Figs. 4 and 5 of my paper that every fourth ventricular systole, and only every fourth, has an auricular systole associated with it in this manner. It is the plateaus of those systoles, and of those alone, therefore, which show the dimpling. The observation is not an original one on my part.

I am well aware how deceptive tracings taken from the region of the apex may be. As Mackenzie pointed out long ago, a systolic plateau may easily be represented by a systolic depression if care is not taken to place the receiver exactly over the apex beat. There may be no accessible apex beat, and that which has been so regarded may have its real character exposed by presenting a depression which is found to be systolic in time. During the systole of the ventricle there is often some lateral movement of the apex, and so the "apex tracing" may present mixed characters, and the movements of respiration may cause the tracing to present a rhythmical transition from plateaus to depressions. Now before I accept a tracing as being that of the apex beat, I try to eliminate these and other sources of fallacy. My receiver is $1\frac{1}{2}$ inch in diameter, and it might I think with advantage be less; a receiver three inches in diameter cannot give a tracing of the "apex beat" alone with accuracy, for this is a phenomenon limited to the apex of the heart. It may be the case that valuable information can be obtained by the use of a receiver of this size, but it would be the resultant of more than one movement and not the effect merely of the forward thrust, of the maintenance of this and of the

recession, and it was these alone with which I was concerned.

Dr. Stephens says I have given "no consideration . . . to the quantity and quality of the pericardial fluid present." That is true; but in none of the cases was there any evidence of fluid in the pericardial cavity. The absence of the ordinary signs of pericardial effusion is, of course, quite compatible with the presence in the sac of a considerable increase in the amount of the physiological secretion. My attention has not been directed to the influence of such small quantities of fluid on the characters of the apex beat.

Dr. Stephens claims more for my tracing (Fig. 5), and sees more in it than I do myself. To me, apart from the points discussed, it shows merely a condition of complete heart-block, and tells me nothing as to its causation; to Dr. Stephens it "suggests a toxic condition." The subsequent history does, I agree, lend support to such a view, with which, however, I was not concerned in my paper, but I cannot read into the tracing anything bearing upon the cause of the block.

I am quoted as having stated that my first case (the italics are my own) died "without any obvious (*sic*) cardiac symptoms." If I am right in supposing that the "*sic*" implies an incorrect use by me of the word "obvious" I do not agree. But the criticism may be on other grounds; and I may be in the position of Diogenes Tenfelsdrökh, who was asked to believe that the reason for the appalling epitaph he had written not being engraved was a "defect of Latinity." I do regret, however, that Dr. Stephens has, quite accidentally, I feel sure, quoted me as saying "the case died." I am glad to feel that I did not express myself in those words. What I wrote was "He"—that is to say the patient—"died."—I am, etc.,

Leeds, June 20th.

T. WARDROP GRIFFITH.

VOLUNTARY HOSPITALS COMMITTEE.

SIR,—In Section 39, with reference to the "contributors' certificates" issued at the Great Northern Central Hospital, the Committee says: "The scheme is in its infancy, and we are unable to express an opinion as to its value." The Committee must here be speaking of "value" in a financial sense only, since the contributor's certificate is merely the old "subscriber's line," which, from the medical standpoint, experience has shown to be an unmitigated evil. It is evil in two aspects. For many years, and as recently as this month, I have heard hospital officers allege that it is difficult to keep beds clear for cases medically urgent because cases not medically urgent are admitted in virtue of holding a line from a subscriber whom it will not do to offend. Thus, in practice, a non-medical condition takes precedence of medical urgency in the admission of patients. In the second place, I have known of the relatives of poor people sacrificing a whole working day in the search for a line which had been demanded after the patient was admitted. This was a means of impressing on them the importance of the hospital subscription in a factory or in a congregation.

No matter how generously the "voluntary" regulations are drawn, in practice constant supervision is needed to guard against an insidious entry of compulsion.—I am, etc.,

Dundee, June 19th.

R. C. BUIST.

CAMBRIDGE DIPLOMA IN HYGIENE.

SIR,—The University of Cambridge, in response to a communication from the League of Red Cross Societies at Geneva, has established a new Diploma in Hygiene.

In order that the scheme may assume an international aspect, it is hoped to bring together men representing the views of different countries; and that candidates from advanced countries, such as America and Scandinavia, as well as those from the more recently reorganized nations of Eastern Europe, may avail themselves of the facilities provided in these classes.

The training is primarily intended to benefit those who wish to familiarize themselves with English methods of sanitary science and practice, and to return to their own countries holding an official certificate that they are qualified to act as officers of health.

The diploma is open to candidates from all countries outside the British Dominions who possess a qualification to practise medicine or surgery which, though not registrable in Great Britain, is recognized by the authority of

the country in which the candidate practises. The diploma is not registrable by the General Medical Council of Great Britain and Ireland.

The full course must extend over a period of nine calendar months, and all candidates must have matriculated and resided in the University for not less than two terms, or for one term and during a long vacation course. The examination is divided into two parts, and the requirements for each part are similar to those demanded for the diploma in public health, with the exception that no detailed knowledge of English public health laws and statutes will be called for. It appears to be more important that candidates should become acquainted with the general principles of the English code of sanitary legislation than that they should possess a detailed knowledge of the legal duties and responsibilities of our sanitary authorities.

Arrangements are now being completed to ensure lodging accommodation not only for D.P.H. students but for the students who intend to take the diploma in hygiene.—I am, etc.,

J. E. PURVIS,
Secretary to the State Medicine Syndicate.
Public Health Laboratory, Cambridge.
June 18th.

COCCYGEAL FISTULAE.

SIR,—I have read Mr. Ernest Miles's comments on my paper on coccygeal fistulae in your issue of June 18th with much interest. There are one or two points which seem to me to call for a reply.

I did not mean to convey that all abscesses and fistulae over the coccyx are necessarily due to dermoids. Ordinary abscesses may, of course, occur in this as in any other situation due to caries of underlying bone, etc.; but the majority of such lesions in this situation will, I believe, prove to be due to the causes I have described.

The condition described by the late Mr. Goodsall as "sinuses over the sacrum and coccyx" is, I feel sure, the same as that which I have described as congenital coccygeal fistulae, in spite of Mr. Miles's arguments to the contrary. As no sections were made in Mr. Goodsall's cases it is not possible to prove this, but the descriptions given of his 10 cases bear such similarity to my own that I feel sure had a microscopical examination of sections of the fistulous tracks been made their congenital origin would have been apparent.

Mr. Miles seems to attach much importance to the opening of these sinuses being in the middle line, and to argue that when the opening is not in the middle line the sinuses cannot be congenital in origin. These congenital sinuses, however, may open in any direction, as the external openings are more often than not due to the secondary septic infection. Only this week I operated upon a patient in whom there was a large fistula with two long tracks running forward, one on each side of the anus, and opening on each side in front of the anus. Posteriorly these tracks communicated with a small cavity over the tip of the coccyx. This cavity proved to be a dermoid cyst of congenital origin, which had suppurated as the result of injury.

Most of the reasons given by Mr. Miles for considering that these sinuses are not congenital are quite unconvincing. Unless a case is seen before there is any sinus, it is not possible to know whether there had previously been a dimple or not. There may be quite a large amount of granulation tissue where suppuration has been going on for some time, and I see no reason why the aperture should not temporarily close, even where the sinus is congenital in origin, since it does not follow that the external opening, which is usually the result of secondary suppuration, is lined with skin. Teeth one would not expect to find in an inclusion dermoid.

With regard to their not being lined with skin, this can only be ascertained by a microscopical examination, as considerable modification of the lining membrane may have taken place as the result of suppuration. These cases are not so rare as Mr. Miles thinks. Since I have been on the look-out for them I have seen quite a number, and I feel sure that if Mr. Miles will have sections cut of such cases, he will be surprised by the number in which he finds evidence of congenital origin, in spite of the history

of injury, and the fact that there had been no previous history of any lump.—I am, etc.,

J. P. LOCKHART-MUMMERY, F.R.C.S.
London, June 18th.

NORTH EUROPEAN CONFERENCE ON VENEREAL DISEASES.

SIR,—In reference to your report of this conference, appearing in the JOURNAL of June 18th, permit me to inform you that the English delegates to the conference consisted of: Colonel L. W. Harrison, Dr. F. N. Kay Menzies, and Mrs. C. Neville Rolfe (Mrs. Gotto), who are well known opponents to immediate self-disinfection as a method of prevention.

Directly I heard that the conference had been arranged, I communicated with the Danish Red Cross at Copenhagen, requesting that my society should be represented at the conference, and the secretary sent me a most courteous reply, intimating that he would be pleased to welcome delegates from the Society for the Prevention of Venereal Disease, but that the selection of such delegates was entirely in the hands of the British Red Cross. I thereupon reiterated my request to the British Red Cross, and received a reply stating that the Society for the Prevention of Venereal Disease could not be represented at the conference, as the League of Red Cross Societies at Geneva had adopted the National Council for Combating Venereal Diseases as the recognized channel in this country, for communications on these subjects, and that they had already selected the delegates mentioned above.

The views of that very large section of the public in this country, who support the policy of immediate self-disinfection advocated by the Society for the Prevention of Venereal Disease, had no opportunity, therefore, of being represented at the conference, and this important aspect of venereal disease prevention was therefore largely neglected.—I am, etc.,

H. WANSEY BAYLY,
London, W., June 17th.
Hon. Sec. S.P.V.D.

THE PATHOLOGICAL MUSEUM AT THE ANNUAL MEETING.

SIR,—The Committee wish to call attention to the importance of the Pathological Museum, and the necessity of making it an adjunct to the work of the Sections.

It is requested that readers of papers in the various Sections, or others taking part in the discussions, should have specimens illustrating these to show, and should communicate at once with the Secretary of the Pathological Museum Committee. This also applies to anyone who wishes to exhibit specimens of general interest.—I am, etc.,

A. F. BERNARD SHAW, M.D.,
Honorary Secretary, Pathological Museum.
College of Medicine, Newcastle-upon-Tyne,
June 16th.

The Services.

INDIAN MEDICAL SERVICE.
ANNUAL DINNER IN LONDON.

The annual dinner in London of the Indian Medical Service took place on the evening of June 15th, when Major-General Sir R. Havelock Charles, G.C.V.O., M.D., Medical Adviser to the Secretary of State for India, was in the chair.

The officers present were:

- Major-Generals: E. E. Giffard, C.S.I., G. F. A. Harris, C.S.I., Sir P. Hehir, K.C.I.E., C.B., C.M.G.
- Colonels: J. K. Close, J. Crummin, V.C., C.B., C.I.E., Sir P. J. Freyer, K.C.B., J. L. Pratt, H. Austen Smith, C.I.E., C. N. C. Wimberley, C.M.G.
- Lieutenant-Colonels: A. Alcock, C.I.E., W. G. P. Alpin, O.B.E., J. Anderson, C.I.E., F. V. O. Beit, G. T. Birdwood, L. P. Brassey, A. W. T. Bust, W. H. Burke, S. H. Burnett, D. G. Crawford, C. D. Dawes, R. H. Elliot, S. C. Evans, A. A. Gibbs, L. Hirsch, C.I.E., C. T. Hudson, C.M.G., E. V. Hugo, C.M.G., J. G. Hulbert, S. P. James, J. G. Jordan, H. Kirkpatrick, W. Glen Liston, C.I.E., R. McCarrison, R. H. L. Meyer, A. Miller, R. A. Needham, C.I.E., D.S.O., J. W. F. Raitt, Sir L. Rogers, C.I.E., A. Spitteler, R. Steen, W. A. Sykes, D.S.O., W. H. Thornhill, W. Vost, J. N. Walker, H. J. Walton, J. H. Tull Walsh, H. R. Woolbert, J. C. S. Vaughan, A. C. Younan, A. W. Cook Young.
- Majors: H. C. Brown, C.I.E., H. P. Cook, W. T. Finlayson, D.S.O., C. A. Godson, M.C., I. Davenport Jones, H. C. Keates, W. D. Keyworth, H. H. King, A. A. McNeight, M. J. Quirke,

F. B. Shettle, E. C. Taylor, C. Thomson, W. P. G. Williams, N. M. Wilson, W. E. Rees Williams, O.B.E.

Captains: P. M. Antia, H. S. Cormack, M. L. C. Irvine, N. G. C. McVean, N. D. Puri.

The guests were the Editors of the BRITISH MEDICAL JOURNAL and the *Lancet*.

The toast to the Service was given by the Chairman: Colonel R. H. Elliot, who proposed the health of Sir Havelock Charles, eulogized his loyal defence of the interests of the Service. The toast was very warmly received and suitably acknowledged.

ROYAL NAVAL MEDICAL SERVICE.

APPROVAL has been given this year by His Majesty in Council for the following alterations in the regulations regarding promotion. They are applicable to medical officers of the Royal Naval Reserve and Royal Naval Volunteer Reserve serving on July 1st, 1919:

(a) Surgeon Lieutenants to be eligible for promotion after six years instead of eight as at present, the promotion of those on the list on July 1st, 1919, being antedated as necessary.

(b) Surgeon Lieutenant Commanders to be eligible for promotion to Surgeon Commander after six years instead of eight as at present, those on the list on July 1st, 1919, being given two years' seniority.

(c) Surgeon Commanders on the list on July 1st, 1919, to be given two years' seniority.

(d) The necessary promotions to the ranks of Surgeon Lieutenant Commander and Surgeon Commander to be made.

(e) The period of sea service required to qualify an officer for promotion to the ranks of Surgeon Lieutenant Commander and Surgeon Commander to be reduced from three to two years.

Officers who are promoted, or whose seniority is antedated under any of these rules, will not receive any advantage in respect thereof as regards pay from a date earlier than July 1st, 1919, but they will be granted such increments of pay as their new rank or seniority may entitle them to as from that date.

NAVAL, MILITARY, AND AIR FORCE HYGIENE.

A MEETING of the Naval, Military, and Air Force Hygiene Group of the Society of Medical Officers of Health will be held at the house of the Society, 1, Upper Montague Street, W.C., on Thursday, June 30th, at 4.30 p.m. Colonel H. W. Grattan, C.B.E., D.S.O., A.M.S., Deputy Director of Hygiene, War Office, will read a paper on "The co-operation between civil and military sanitary authorities during a grave national emergency."

HONOURS.

THE following appointments to the Order of the British Empire are announced:

To be Officers (Military Division).—Major (acting Lieut.-Colonel) John B. Dalzell-Hunter and Captain (acting Lieut.-Colonel) James Bennett Hance, of the Indian Medical Service, in recognition of services rendered in connexion with minor military operations within the Indian Empire or in territories adjacent thereto; Captain William Hunt, M.C., R.A.M.C., attached Egyptian Army, in recognition of valuable services rendered in connexion with military operations against the Garjak Nners, Sudan.

Universities and Colleges.

UNIVERSITY OF OXFORD.

At a congregation held on June 16th the degree of Doctor of Medicine was conferred on Herbert C. Squires.

UNIVERSITY OF CAMBRIDGE.

DR. G. H. F. NUTTALL'S reappointment for three years as Quick Professor of Biology expires in November, 1921, and a fresh election to the chair will be held on July 20th.

Dr. Louis Cobbett has been reappointed University Lecturer in Pathology.

At the congregation held on June 10th the degree of Doctor of Medicine was conferred on Mark Avent (Gonville and Caius College).

UNIVERSITY OF LONDON.

Semon Lecture, 1920-21.

DR. W. JOBSON HORNE, President of the Laryngological Section of the Royal Society of Medicine, will deliver the Semon lecture in the lecture hall of the Royal Society of Medicine, 1, Wimpole Street, W.1, on Tuesday, July 5th, at 5 p.m. The chair will be taken by Mr. Herbert Tilley, F.R.C.S. The subject of the lecture is "The relationship of the larynx to pulmonary tuberculosis" (with lantern illustrations).

ROYAL COLLEGE OF PHYSICIANS OF LONDON.

AN extraordinary comitia of the Royal College of Physicians of London was held on June 15th, the President, Sir Norman Moore, Bt., occupying the chair. Communications were received 1) from the Secretary of the Royal College of Surgeons:

these were read and entered on the minutes; (2) from Jngalkisor Adhya, M.B., M.R.C.P., resigning the Membership of the College; this was accepted. Sir Humphry D. Rolleston was appointed a representative of the College on the Court of Governors of the University of Sheffield in place of Dr. T. D. Acland. A report from the representative of the College on the General Medical Council concerning the meeting of the Council held in May last was received and ordered to be entered in the minutes.

After some discussion the following resolution was passed and referred to the Committee of Management for report to the College:

That every candidate for the conjoint diploma of the Royal College of Physicians and the Royal College of Surgeons shall be required to produce evidence of adequate training in diseases of children, and that the final examination shall include examination in diseases of children.

The President then dissolved the comitia.

Obituary.

CHARLES JAMES MORTON, M.D., C.M. EDIN.

DR. CHARLES JAMES MORTON, who died at Territet, Switzerland, on May 28th, at the age of 57 years, received his medical education at Edinburgh, taking the degree of M.B., C.M., and the diplomas L.R.C.P., L.R.C.S. Edin., and L.R.F.P.S. Glasg. in 1886. After some time spent in study in London and Vienna, he took his M.D. degree in 1890, and in the same year settled at Walthamstow, where he practised for fifteen years and was much beloved by patients of all classes. He took great interest in the work of the British Medical Association, was secretary of the East London and Essex District of the Metropolitan Counties Branch in 1900-1, secretary of the Walthamstow Division during 1903-5, and Representative of the Walthamstow Division in the Representative Body for 1904-7. After leaving Walthamstow he migrated to Welbeck Street, where he practised as a radiologist. He was appointed radiologist at Guy's Hospital in 1907, doing much good work there till 1912, when failing health compelled him to resign.

On the outbreak of war Dr. Morton immediately offered his services, and received his commission in the Royal Army Medical Corps in 1914, being posted as radiologist to the Pavilion (Indian) Hospital, Brighton, and afterwards in a similar capacity to the Kitchener and 2nd Eastern Hospitals. He served until March, 1920, but his health having suffered severely from the labours of these strenuous years, he was obliged to give up active work and retire to Switzerland.

In addition to other offices Dr. Morton was consulting physician to the Walthamstow Dispensary and consulting radiologist to the Surrey County Hospital. Though not a prolific writer, he contributed a number of very practical articles on radiology to medical periodicals. His loss will be felt by a wide circle of friends, especially those of his profession whose interests he always had at heart. He leaves behind a widow and daughter.

Medical News.

IT has not been found possible to arrange for a meeting in July of the Dermatological Section of the Royal Society of Medicine.

MR. A. M. M. FORBES, coroner for East Middlesex, has been elected President of the Coroners' Society for England and Wales.

THE sixth annual meeting of the National Council for Combating Venereal Diseases will be held at the Morley Hall, George Street, Hanover Square, W., on Tuesday, June 28th, at 4.15 p.m., when Lord Gorell will preside.

DR. R. M. F. PICKEN, Assistant Medical Officer of Health, Glasgow, has been appointed Medical Officer of Health of the City of Cardiff and Port Sanitary Officer.

A CONFERENCE under the joint auspices of the Central Committee for the Care of Cripples, 19, Berkeley Street, London, W.1, and the Newcastle Invalid Children's Aid Association, 17, Ellison Place, Newcastle-upon-Tyne, will be held at Newcastle on July 19th, 1921. The subjects for discussion will be the treatment and education of physically defective children and the best methods of administration and co-ordination to procure the same. Programmes will be ready by the first week in July.

THE KING, on the occasion of the opening of the Northern Parliament of Ireland, conferred the honour of knighthood upon Dr. John Walton Browne, Deputy-Lieutenant for county Antrim, and surgeon to the Belfast Ophthalmic Hospital.

THE annual general meeting of the Medico-Legal Society will be held at 11, Chandos-street, W.1, at 8.15 p.m., on Thursday, July 7th (not Tuesday, June 28th, as previously announced). At 8.30 Dr. Louise Mellroy will read a paper on some factors in the control of the birth-rate, to be followed by a discussion.

THE National Housing and Town Planning Council has arranged for a number of conferences to be held in various localities during the next six weeks. The places selected are Manchester, Leeds, Llandrindod Wells (for Wales and Monmouthshire), Bristol, and Birmingham. The conference for the Home and Eastern Counties will be held at Caxton Hall, Westminster; for the Northern and Eastern Midland Counties at Newcastle-on-Tyne; and for other parts of the Midlands at Birmingham. The conference for Scotland has been arranged by the Scottish National Committee; it will sit on July 11th and 12th, under the presidency of Sir Henry Ballantyne, Chairman of the Royal Commission on Housing in Scotland, and will be addressed by Sir George MacRae, the Chairman of the Scottish Board of Health. The conferences, it is expected, will protest against proposals, attributed to the Ministry of Health, for cutting down the schemes of local authorities.

ON June 22nd a monument was unveiled at Utrecht to the celebrated ophthalmologist, Franciscus Cornelis Donders.

THE Research Defence Society will hold its annual general meeting on Wednesday next, June 29th, at 3.30, at the house of the Medical Society of London (11, Chandos Street, Cavendish Square). The chair will be taken by Lord Lamington, G.C.M.G., G.C.I.E. A short address will be given by Dr. H. H. Dale, C.B.E., F.R.S., on the work of the National Institute for Medical Research. The Society seeks to help the public to understand the aims and achievements of scientific medicine, and all interested are invited to attend the meeting and to bring friends. Specimens will be shown after the meeting, and tea and coffee will be served at 4.30.

THE seventeenth South African Medical Congress will be held in Cape Town from October 10th to 15th, with Dr. Hugh Smith, of Cape Town, as president. Every registered medical practitioner in South Africa is being invited to attend.

THE second English-speaking conference on infant welfare, organized by the National Association for the Prevention of Infant Mortality and National Baby Week Council, will be held at the Central Hall, Westminster, instead of at the Kingsway Hall, as previously announced, on July 5th, 6th, and 7th. Lord Astor, formerly Parliamentary Secretary to the Minister of Health, will preside and deliver the inaugural address. The subjects for discussion include "Residential provision for mothers and babies," "The physiological and economic aspects of the milk supply," "Uniformity of method and practice in the conduct of infant welfare centres," "Inheritance and environment as factors in racial health," and there will be special lectures in the evenings. In connexion with the conference a child welfare exhibition will be open from July 5th to July 9th, on the ground floor of the Central Hall, Westminster, and demonstrations will be given there on the care of the baby and on the work in day nurseries and Montessori schools. Throughout the week a large number of infant welfare centres and similar institutions will be open for inspection by delegates to the conference. For further particulars and for tickets and their prices, application should be made to Miss Halford, secretary, National Association for the Prevention of Infant Mortality, 4 and 5, Tavistock Square, W.C.1.

IN order to give effect to the decision of its governing body to appoint an advisory committee of experts in industrial hygiene, the International Labour Office has dispatched a letter to the Governments of Belgium, France, Germany, Great Britain, Italy, Japan, the Netherlands, Spain, Sweden, and Switzerland, requesting each of them to nominate as a member of this advisory committee one of its health inspectors or factory inspectors. The members of the committee in the various countries will keep in touch with the International Labour Office and its Industrial Hygiene Section by correspondence; the committee will meet when convened by the governing body, preferably on the occasion of the International Labour Conference.

THE sixth annual meeting of the National Council for Combating Venereal Diseases will be held in the Barnes Hall of the Royal Society of Medicine, 1, Wimpole Street, W., on Tuesday, June 28th, at 4.15 p.m., and not at the Morley Hall, George Street, Hanover Square, as previously arranged.

THE annual tournament of the Medical Golfing Society was held on June 16th at the Walton Heath golf course. The day passed very successfully and the pleasure of the competitors was largely due to the excellent condition of the course. The results of the various competitions were as follows: *Lancet Cup*, open to members of the medical profession, and given for the best scratch return under bogey—winner, H. D. Gillies, 3 up; *Henry Morris Challenge Cup*, under handicap: Class A: 1, C. E. Finney, 3 up; 2, J. A. Torrens, 2 up; last 9 holes, Murray Thompson, 2 up. Class B: 1, Eric Gandy, all square; 2, Sir Charles Ryall, 1 down; last 9 holes, E. H. Shaw, 1 up.

AT the St. Antoine Hospital, Paris, a special course on diseases of the digestive system, consisting of lectures in the mornings and afternoons, followed by practical work, will take place during the week July 11th to 18th. The fee is 100 francs; application should be made to Dr. Le Noir at the Hospital (Salle Arant).

THE Ministry of Health has issued a revised list of sanatoriums and other residential institutions approved by the Minister for the treatment of persons suffering from tuberculosis, and resident in England and Wales, with the names of the administrative counties and county boroughs in which the institutions are situate. The list is dated May 9th, 1921, and can be obtained through any bookseller or direct from H.M. Stationery Office, price 3d. net.

Letters, Notes, and Answers.

As, owing to printing difficulties, the JOURNAL must be sent to press earlier than hitherto, it is essential that communications intended for the current issue should be received by the first post on Tuesday, and lengthy documents on Monday.

ORIGINAL ARTICLES and LETTERS forwarded for publication are understood to be offered to the BRITISH MEDICAL JOURNAL alone unless the contrary be stated.

CORRESPONDENTS who wish notice to be taken of their communications should authenticate them with their names—of course not necessarily for publication.

AUTHORS desiring reprints of their articles published in the BRITISH MEDICAL JOURNAL are requested to communicate with the Office, 429, Strand, W.C.2, on receipt of proof.

IN order to avoid delay, it is particularly requested that ALL letters on the editorial business of the JOURNAL be addressed to the Editor at the Office of the JOURNAL.

THE postal address of the BRITISH MEDICAL ASSOCIATION and BRITISH MEDICAL JOURNAL is 429, Strand, London, W.C.2. The telegraphic addresses are:

1. EDITOR of the BRITISH MEDICAL JOURNAL, *Aitology, Westrand, London*; telephone, 2630, Gerrard.
2. FINANCIAL SECRETARY AND BUSINESS MANAGER (Advertisements, etc.), *Articulate, Westrand, London*; telephone, 2630, Gerrard.
3. MEDICAL SECRETARY, *Medisera, Westrand, London*; telephone, 2630, Gerrard. The address of the Irish Office of the British Medical Association is 16, South Frederick Street, Dublin (telegrams: *Bacillus, Dublin*; telephone, 4737, Dublin), and of the Scottish Office, 6, Rutland Square, Edinburgh (telegrams: *Associate, Edinburgh*; telephone, 4361, Central).

QUERIES AND ANSWERS.

MEMBER B.M.A. for twenty-five years wishes to hear the opinion of any colleague who has been using a kitchen stove made entirely for anthracite, with particular reference to cooking meals, hot water and cleanliness.

"SENEX," who has been asked to act as judge at a baby show, wishes to know how "points" should be given.

An article on Baby Shows and How to Judge Babies, by Dr. Eric Pritchard, appeared in *National Health*, June, 1917. The National Baby Week Council (5, Tavistock Square, London, W.C.1) has issued a leaflet (No. 6) on "Baby Shows and How to Judge Babies." Single copies can be obtained for 2d. post free, and score sheets for use by judges at baby shows for 6d. a dozen.

INCOME TAX.

"N." writes inquiring as to the position of practitioners who "spend a considerable part of the year abroad, engaging there in practice."

* * * Tax is chargeable under Schedule D "in respect of the annual profits or gains arising or accruing to any person residing in the United Kingdom from any trade, profession . . . whether the same be respectively carried on in the

United Kingdom or elsewhere." If our correspondent maintains a residence in this country and actually resides here personally during a portion of any financial year, we anticipate that he would be held liable on the whole of the net profits; if he was not in this country during the year we consider he could claim exemption on his foreign earnings. The question is not one of domicile, but of residence. "Domicile," as our correspondent is no doubt aware, has a technical legal meaning. A man might give up his residence here and with his family reside wholly abroad, while still retaining his English domicile.

"NESTOR" has for fifteen years returned and been assessed on the basis of three years' average receipts, "less expenses for the year in question." He is now asked to have his books audited and to supply a copy of the resulting profit and loss account.

We advise "Nestor" to point out that he has made his return on a cash basis for fifteen years, and that that method is established as the appropriate method of dealing with medical profits over the whole country. It has to be borne in mind that this system, however, breaks down when any special cause enters to increase or decrease the receipts; as, for instance, in the case of the purchase of an additional practice or the sale of a panel connexion, but we assume that there has been no such cause in this case. Our correspondent, however, is not quite correct on the question of expenses; these, like the receipts, should be taken on the basis of the three years.

"H." had to buy a second car in 1920 owing to the fact that his first car had broken down and was necessarily out of commission for some time. The car was bought for £350 and sold for £100 when the first car became available.

On the facts stated, and assuming that the two cars were not used together for any appreciable period, we are of opinion that the loss of £250 on the purchase and resale of the second car can properly be treated as an expense incurred in the overhaul of the first car.

LETTERS, NOTES, ETC.

DENTAL CARIES, APPENDICITIS, AND GASTRIC ULCER.

DR. W. E. NICKOLLS DUNN (London, W.) writes: In his letter from Mauritius in the JOURNAL of June 4th Dr. Andrew Balfour comments on the prevalence of ankylostomiasis. He continues, "Other worm infections are exceedingly common, and so, be it noted, is appendicitis." For several years I was in charge of the Luxor Hospital for natives in Upper Egypt, and much to my surprise I never saw a case of appendicitis. Ankylostomiasis was almost universal amongst the men. For many years I have pointed out that my patients had for the most part sound teeth, and that I never saw appendicitis, gastric ulcer, or cancer of breast or stomach. The town arab acquires dental caries, and the Egyptian surgeons inform me that they see appendicitis amongst the arab children in Cairo. In my opinion our diet, which causes dental caries, may also cause the appendicitis, ulcer, and cancer of the stomach. It is my expectation that with prevention of dental caries the above-named diseases will become infrequent.

NEED FOR POST-GRADUATE INSTRUCTION IN MOUTH SEPSIS.

"X. Y. Z." writes with reference to the difficulty "A. B. C."—a dental surgeon—is experiencing in arranging demonstrations, as part of a post-graduate course, at the hospital to which he is attached; in my opinion, no post-graduate course in medicine is complete without this subject being fully dealt with; indeed, so strongly do I feel about it that I would go farther and say that if time is a factor to be considered, then some of the less important classes should be cut out in order to give this subject a proper opportunity of being taught. The holding of such an opinion seems all the more justified after reading the article "The coming of age of oral sepsis," by Dr. William Hunter, which appears in the JOURNAL of June 11th, p. 859.

THE CHEMISTS' EXHIBITION.

THE Chemists' Exhibition, the twenty-second in a series organized by the *British and Colonial Pharmacist*, was held during five days of this week at the Central Hall, Westminster. The exhibits were confined to medicinal, dietary, and toilet preparations, but even with this restriction the contributions of nearly a hundred firms crowded two large floors. The general appearance of the stands said much, not only for skill and ingenuity in chemical manufacture, but for that decorative ability which makes the most of the product. The pharmaceutical craft is very old, receptive though it be of modern notions, and one firm (Allen and Hanburys, Ltd.), amid a tempting display of their gelatine capsules and other goods, summoned up some ghosts of former times by exhibiting their old prescription books and ledgers, dating

back to the eighteenth century, from which many quaint extracts might be made. Another old firm, with considerably more than a century behind it—Howards and Sons, Ltd.—made a feature of their standard ether and quinine salts and aspirin tablets; and then again, to show the stability of British firms, there was Pears' soap, which began its career in the reign of George III. Many exhibitors emphasized the wide range of their products, while others concentrated on a single article. Among the former were Parke, Davis and Co., with their lozenges and pills and soaps and peroxide solutions, making a very effective display, Genatosen, Limited, the British purchasers of the Sanatogen Company, and the Hoffmann-La Roche Works, from which came alkaloids, fine chemicals and pharmaceutical products. On the other hand, one large stall—that of William Browning Co., Ltd., a pioneer firm along this line—was devoted to purified petroleum and petroleum jellies. British Colloids, Ltd., placed in the forefront two of their colloidal preparations—one of metallic silver, and the other containing iron in colloidal form. Then there were on view such well known preparations as Glaxo products, Horlick's malted milk, and, on another range of application, were soaps and ointments at the stand of Newbery and Sons, Ltd., the Sanitas fluids and powders and embrocations, and the Milton disinfectant, a clear hypochlorite fluid. A little aside from the strict purpose of the exhibition, but none the less interesting, was a display of supports, pads, and cushions for the feet, shown by the Scholl Manufacturing Co., Ltd., and a range of natural mineral waters, brought together by Ingram and Royle, Ltd., the product of half a hundred springs, from Aix-les-Bains to Woodhall Spa. Elsewhere in the exhibition one noted many improvements in the way of syringes, atomizers, tubes, sprinklers, bottle-caps, and the like. The ingenuity shown in this direction seems to make an advance with each successive exhibition.

POST AND PROPTER.

"T. L. B." writes: A town medical society, taking its annual half holiday this week at a remote moorland village, where the only resident doctor had died a short time previously, was confronted by the following typewritten notice in the church signed by the two chairmen of parish meetings:

"A public meeting of the inhabitants of B— and H— will be held in the school at B— on Saturday, April 30th, 1921, at 7 p.m., to discuss the possibility of securing the services of a doctor for the district; and to consider the question of providing a hearse for the two parishes."

This apparent slur on the profession caused, at first, some consternation, but serene feelings were restored when it was recognized that the villagers had apparently never felt the need of a hearse until they were without a doctor.

VACANCIES.

NOTIFICATIONS of offices vacant in universities, medical colleges, and of vacant resident and other appointments at hospitals, will be found at pages 30, 31, 34, 35, 36, and 37 of our advertisement columns, and advertisements as to partnerships, assistantships, and locum tenencies at pages 32 and 33.

THE appointments of certifying factory surgeon at Ruabon (Denbigh) and West Drayton (Middlesex) are vacant.

THE post of one of the Medical Referees under the Workmen's Compensation Act, 1906, for the Falmouth and Truro, Helston, Newquay, Penzance, Redruth, and St. Austell County Courts, in Circuit No. 59, is vacant. Applications to the Private Secretary, Home Office, by July 13th.

Cultivation of Medicinal Plants in Scotland, by R. Glode Guyer, is the title of a little book which has been published at the price of 1s. 6d. by the well-known drug firm of Duncan, Flockhart and Co., Edinburgh and London. An interesting account of the romantic early history of the cultivation of medicinal plants in Scotland introduces the story, illustrated by photographs, of the establishment in 1915 by Messrs. Duncan and Flockhart of gardens at Edinburgh for the cultivation of medicinal plants under their laboratory control.

SCALE OF CHARGES FOR ADVERTISEMENTS IN THE BRITISH MEDICAL JOURNAL.

	£	s.	d.
Six lines and under	0	9	0
Each additional line	0	1	6
Whole single column (three columns to page)	7	10	0
Half single column	3	15	0
Half page	10	0	0
Whole page	20	0	0

An average line contains six words.

All remittances by Post Office Orders must be made payable to the British Medical Association at the General Post Office, London. No responsibility will be accepted for any such remittance not so safeguarded.

Advertisements should be delivered, addressed to the Manager, 429, Strand, London, not later than the first post on Tuesday morning preceding publication, and, if not paid for at the time, should be accompanied by a reference.

NOTE.—It is against the rules of the Post Office to receive *postæ restantæ* letters addressed either in initials or numbers.

THE
British Medical Journal.

THE JOURNAL OF THE BRITISH MEDICAL ASSOCIATION.

SUPPLEMENT

CONTAINING

CURRENT NOTES ON THE WORK OF THE ASSOCIATION

REPORTS OF CONFERENCES

MEETINGS OF BRANCHES AND DIVISIONS

THE GENERAL MEDICAL COUNCIL

MEDICAL BILLS IN PARLIAMENT

NATIONAL INSURANCE PROCEEDINGS

NAVAL AND MILITARY APPOINTMENTS

CORRESPONDENCE, ETC.

VOLUME I, 1921.

London :

PRINTED AND PUBLISHED AT THE OFFICE OF THE BRITISH MEDICAL ASSOCIATION,
429, STRAND, W.C.

INDEX TO SUPPLEMENT FOR VOLUME I, 1921.

A.

ADAMS, W. Coode : London Panel Committee, 14
 Admiralty surgeons' fees. *See* Fees
 Air Force, Royal, Medical B anch, 19, 24, 48, 84, 92, 96, 100, 104, 164, 180, 187, 196, 214, 236
 Anaesthetists' fees. *See* Fees
 Army, British, 15, 19, 24, 35, 40, 47, 67, 75, 80, 84, 92, 95, 100, 104, 164, 179, 187, 196, 203, 213, 227, 236
 Army, British : Army Medical Service, 19, 24, 35, 40, 47, 49, 75, 80, 84, 92, 95, 100, 104, 164, 179, 187, 196, 203, 213, 227, 236—Alteration of dress distinctions, 49
 Army, British : Defence Force, 164, 180, 188, 196, 203, 214, 228, 235
 Army, British : General Reserve of Officers, 24
 Army, British : Overseas Forces, 180
 Army, British : Royal Army Medical Corps, 15, 19, 24, 35, 40, 47, 49, 67, 75, 80, 81, 84, 92, 100, 104, 164, 179, 187, 196, 203, 213, 227, 236—Present position of R.A.M.C. officers, 10—Alteration of dress distinctions, 49—Pay of, 81
 Army British : South African Medical Corps, 180
 Army, British : Special Reserve of Officers, 20, 36, 76, 80, 104, 228, 236
 Army, British : Territorial Force, 16, 20, 36, 48, 68, 76, 80, 84, 92, 96, 100, 104, 164, 180, 188, 214, 228, 236
 Army Medical Service : Royal Army Medical Corps, 16, 20, 36, 48, 68, 76, 80, 84, 96, 100, 104, 164, 180, 188, 214, 228, 236
 Army, British : Territorial Force Reserve, Army Medical Service, 68
 Army, British : Territorial Force Reserve, Royal Army Medical Corps, 20, 76, 80, 84, 92, 104, 188, 214, 228
 Army, British : Volunteer Force, 80
 Army, Indian. *See* Indian Medical Service Association, British Medical : Aims and objects of, 205
 Association, British Medical, Annual Meeting 1921, Newcastle-upon-Tyne : The sections, 85, 93, 160, 207, 239—Hotel accommodation, 97, 168, 191—Arrangements, 101, 163, 229—Programme, 189, 215, 229—Provisional timetable, 191—Accommodation, 191—Annual exhibition, 229—The temperance breakfast, 229—Religious services, 233
 Association, British Medical, Annual Representative Meeting, 1921 : Notices of motion, 101, 160, 224—Provisional agenda, 181
 Association, British Medical : Annual reports of Branches and Divisions, 97
 Association, British Medical, and the need for a central organization, 206
 Association, British Medical, Council : Proceedings, 9, 49, 69, 184—Dr. Macdonald's mission to South Africa, 70, 165—Annual report of Council and balance sheet, 105 *et seq*—Election, 165, 197, 206, 222, 230—Appendix to report : Return of attendances, 172
 Association, British Medical : Question of it becoming a federation, 53—Report of Council on, 55—Discussion at meeting of the Reigate Division, 169
 Association, British Medical, Handbook, 41
 Association, British Medical, Library : Lending department, 42—Hours of opening, 166
 Association, British Medical, and the Life Offices Association, 206
 Association, British Medical, membership of, 21, 97
 Association, British Medical : Members of long standing or retired from practice, 21
 Association, British Medical : Scholarships and grants in aid of scientific research, 54, 91, 166, 177, 203, 230
 Association, British Medical, value of to individual members, 206
 Attendances at Council and committees, 172

B.

BALL, E. J. : Insurance medical records, 23
 Banff, Elgin, and Nairn Division : Election of officers, 223—Question of federation, 223—Vote of thanks, 223
 Bath Division : Annual meeting, 222—Election of officers, 222—Annual report of central council, 222
 Belfast Division : Election of officers, 12—Special constabulary, examination fees for, 12—Paper by Dr. Robert Reid, 19
 Belgrade University library, 233
 BENNETT, W. G. : The Dental Bill and insurance practice, 84
 BENSON, Philip Lambert : Insurance remuneration, 195
 PHILIPS, H. B. : The new system of medical records, 66
 Birmingham : Conference of Representatives of Panel Committees (Group F) at, 51
 Birmingham Panel Committee, 47
 Blackpool Division : Address by Medical Secretary, 31
 BLOXSON, H. : Insurance medical records, 18

Board, Central Midwives (Scotland), constitution of, 31
 Bournemouth Division : Annual meeting, 222
 BRACKENBURY, H. R. : Dental anaesthetics, insurance records, 95
 Bradford Division : British Medical Association Lecture, 198
 Bradford Hospital. *See* Hospital
 Brighton Panel Committee, 67
 British Medical Association. *See* Association
 BRODRIBB, F. A. : Insurance medical records, 15
 BROWN, John : Central Insurance Defence Fund, 34
 BUCHAN, G. F. : National health and the practitioner, 186
 Buckinghamshire Division : Meeting at Aylesbury, 98
 Buckinghamshire insurance practitioners, meeting of, 195
 Buckinghamshire Local Medical and Panel Committee : Various business, 196
 "Buff Book," 197
 BRIST, R. C. : The Medical Guild on the Interim Report of the Scottish Consultative Council, 32
 BURMAN, Fredk. J. : Insurance medical records, 23
 Bury Division : Consultative Council's report, 74—Dangerous Drugs Regulations, 74

C.

CAIRD, Francis M. : Medical service scheme for Scotland, 195
 Camberwell Division : Dangerous Drugs Regulations, 43—National Provident Scheme for Hospitals and Additional Medical Services, 198
 CAMPBELL, Jno. : Dangerous Drugs Regulations, 46
 Cape of Good Hope (Western) Branch : Address on the early diagnosis of tuberculosis by the President (D. P. Marais), 179
 CARDALE, H. J. : London Panel Committee, 14
 CARRUTHERS, Thomas : The new medical record cards, 84
 Central help, need of early application for, 10
 Central organization, need for a, 206
 Central Professional Committee, proposed, 25
 Chemists' hours, 207. *See also* Insurance
 Cheshire (Mid) Division : Annual meeting, 31—Address by Medical Secretary, 31
 Chester and district, future of the medical services in (John Elliott), 89
 Chesterfield Division : Annual report, 98
 Chichester and Worthing Division : Diagnostic significance of abdominal pain in the adult (Robert Hutchison), 193
 Cinematograph Exhibition, Medical, 101
 City Division : Dinner, 19, 95—E. W. Goodall : Nervous group of the acute infectious fevers, 38—W. McAdam Eccles : Early diagnosis of acute abdomen, 74—Medical officers invited to become members of the Division, 186—National provident scheme for hospitals, 186
 CLARKE, Sidney : Supply of drugs in rural areas, 23—Election of Panel Committees, 202
 Cleveland Division : Financial statement, 44
 Fees for police cases, 44—Annual dinner, 44
 Election of officers, 223—Resolution re removal of placenta, etc., 223—Fees for practitioners called by the police, 223
 COATES R. : Fees for doctors called in by midwives, 34
 Colonial Medical Services, 93, 208—Letter from Colonial Office, 205
 Committees of inquiry, 53
 Conference of hospital staffs. *See* Hospitals, voluntary
 Contract Practice Subcommittees, 22
 Cornwall, East, Division : Election of officers, 12—Proposed division of area into two divisions, 12—Report of Consultative Council, 12
 Cornwall, West, Division : Question of federation, 223
 Coroners' inquests, mileage for, 54
 COUNCIL, GENERAL MEDICAL : Appointment of Registrar, 225
 Buff telephone book, 79
 Dangerous Drugs Regulations, 211
 Dental education and examination, 225
 Election of committees, 201, 225
 Executive Committee, 79
 Finance, 201
 Health Ministry and post-graduate study, 79
 Inspection of public health examinations, 225
 Medical education regulations, 225
 Medical Register, correction of, 79
 Medical registration, 31
 Penal cases, 212
 President's address, 199
 Reciprocity with Belgians, cessation of, 79
 Recognition of examiners, 225
 Results of qualifying examinations, 225
 Registration of medical students, 31, 225

Coventry Panel and Local Medical Committee, 203
 Croydon Division : Annual meeting, 223—Clinical meeting, 223

Current Notes :

Anaesthetists' fees in insurance practice, 97, 160
 Annual Meeting : Sections, 85, 93, 160, 207, 229—Arrangements, 101, 229
 Annual reports of Branches and Divisions, 97
 Annual Representative Meeting : Motions, 101
 Army Medical Service, 49
 Association, value of to individual members, 206
 Belgrade University library, 233
 "Buff Book," 197
 Central Professional Committee, proposed, 25
 Certification under the Workmen's Compensation Act, 54
 Chemists' hours, 207
 Colonial Medical Service, 93
 Committees of inquiry, 53
 Compensation for loss of public health appointment, 54
 Contract Practice Subcommittees, 22
 Council election, 165, 197, 206, 230
 Council meeting, 49
 Dangerous Drugs Act, Draft Regulations, 29, 41, 49, 54, 229
 Deputation from Panel Conference to Ministry of Health, 8
 Directory, a classified, 77
 Dispensing in rural areas, 97
 Distribution Committee on Central and Mileage Pools, 10, 42
 Earl Haig's Fund for Officers and ex-Service Men, 54
 Emergency treatment by insurance practitioners, 97
 Encephalitis lethargica schedule in London, 21
 Federation, question of the Association becoming in part a, 53
 Fees of Admiralty surgeons and agents, 77, 165
 Fees for examination of Civil Service candidates, 221
 Fees for cases of miscarriage and abortion, 29
 Fees of practitioners called in by midwives, 233—(Scotland), 72, 185
 Fees for treatment of school children in Scotland, 25
 Government committees, reports of, 221
 Handbook of the Association, 41
 Health certificates for emigrants, 159
 Home Office regulations as to dangerous drugs, 25
 Hospitals Committee, 21
 Hospitals, voluntary, conference of representatives of staffs of, in Scotland, 25
 Indian Medical Service and the new scale of pay, 8, 93—Civil branch, 50, 85
 Inquests, payment of travelling expenses in connexion with, 229
 Insurance Acts Committee : Deputation to Ministry of Health, 8
 Insurance index registers, inflation of, 77
 Insurance medical records, 10, 41—Memorandum, 41
 Insurance practitioners, hints for, 184
 Insured persons in hospital, treatment of, 207
 "Juveniles" and contract rates, 8
 Library, lending (of the Association), 42—Hours of opening, 166
 Logical conclusion, 206
 MACDONALD, J. A. : His visit to South Africa, 165—Presentation, 221, 230, 233
 Medical aid institutions, approved : Application for extension of area, 21
 Medical books for Serbia, 85
 Medical certificate on behalf of a jury-woman, refusal of, 81
 Medical cinematograph exhibition, 101
 Medical officers of health, security of tenure of, 85, 233
 Medical record cards. *See* Insurance
 Medico-Political Committee, work of, 72
 Medico-Sociological Section at Newcastle, 207
 Membership of the Association, 21, 97
 Members of long standing or retired from practice, 21
 Mileage for coroners' inquests, 54
 Mileage fees for pension referees, 93
 Mileage returns (1921), 184
 Need for a central organization, 206
 Need of early application for central help, 10
 New South Wales Branch, 197
 New Zealand Branch, 221
 Nursing schemes for insured persons, 207
 Paying patients in Poor Law infirmaries, 159
 Poor Law hospitals and civil needs, 25
 Postal rates, the new, 221, 229
 Post-graduate education, 85
 Public Health Committee's work, 54

Current Notes (continued):

R.A.M.C. officers: Present position of, 10—Pay of, 81
Religious services at annual meeting, 233
Research scholarships, regulations as to, 166
Salaries of university teachers and professors, 29
Scholarships and grants in aid of scientific research, 54
Scottish Committee, 42
Unemployment Insurance Act and doctors' domestic servants, 21, 41
Value of the Association to individual members, 206
Wellhouse Hospital, Barnet, 81
Women jurors, exemption of, 165
Yorkshire Divisions: Tour of Medical Secretary, 101

D.

DAIN, H. Guy: Medical records, 46
Devon County Panel Committee: Medical records, 47
Directory, a classified, 77
Distribution Committee. *See* Insurance
Dorset and West Hants Branch: Annual meeting, 222
Drugs, dangerous: Home Office Regulations, 25, 29, 41, 49, 54—Protest by the British Medical Association 37, 75—Letter from Home Office, 49, 63—Parliamentary note on, 54—Meeting at House of Commons, 77—Home Office Committee appointed, 79—Summary of evidence before Home Office Committee, 82—Committee's report, 210—General Medical Council and, 211
DUDLEY, P. Hughes: Evening surgery, 47
DUNSTAN, R.: London Panel Committee, 14
Durham County Medical and Panel Committee: Communications from London and Newcastle-on-Tyne Panel Committees, 15

E.

EALES, G. Young: The dextro-filing case, 40
Ealing Division: Election of officers, 50—The work of the Association, 50
EATES, A. R.: Medical benefit, 27
EDWARDS, C.: Central Insurance Defence Fund, 28
ELLIOTT, John: Future of the medical services in Chester and the district, 89
Emigrants, health certificates for, 159
Encephalitis lethargica schedule in London, 21
Essex, North-East, Division: Clinical meeting, 11—Dinner, 11—Address by Medical Secretary, 11
Essex, South, Division: Some clinical bits and pieces (Herbert French), 88
Exeter Division: Medical cinematograph exhibition, 101

F.

FARMAN, R. J.: London Panel Committee, 14
Fees of Admiralty surgeons and agents, 77, 165
Fees, anaesthetists', in insurance practice, 97, 99, 160, 171, 187, 202
Fees for doctors called in by midwives, 12, 233—(Scotland), 72, 185—Ministry of Health's new scale of fees, 12
Fees for examination of Civil Service candidates, 221
Fees, mileage, for pension referees, 93
Fees for cases of miscarriage and abortion, 29
Fees for treatment of school children in Scotland, 25
FLEMING, Chas. E. S.: Record cards, 27—Anaesthetists' fees in insurance practice, 202
FORBES, Alex.: New system of medical records, 44
FORTY, A. Alan: Overlapping ministries, 33
FORBERGILL, E. Rowland: Proposed opportunities for affiliating bodies concerned with allied sciences, 171
FOX, Adam: Medical records in courts of law, 18
FRENCH, Herbert: Some clinical bits and pieces, 88
Fund Earl Haig's, for Officers and ex-Service Men, 54

G.

General Medical Council. *See* Council
GENGE, G. Gilbert: Anaesthetists' fees in insurance practice, 202
Glamorgan, North, Division: Monthly report of Medical Secretary, 64—Dangerous Drugs Act, 64—Address by T. R. Llewellyn, 64
Glasgow and West of Scotland Branch: Annual meeting, 88—Annual meeting of the Association (Glasgow, 1922), 88
Gloucestershire Panel Committee: Medical records, 67
GODFREY, John Thomas, convicted on a charge of fraud, 85—General Medical Council and the penal case of, 213
GOVER, Frederick Percy Richard, penal case of, 212

Government Committees, reports of, 221
GREGG, E. A.: London Panel Committee, 14

H.

Haig Fund. *See* Fund
Harrow Division: Record cards for insured patients, 26—Question of federation, 178—Scheme for hospital and additional medical services, 178—Election of officers, 223—Address by H. S. Souttar, 223—Dinner to H. S. Wansbrough Jones, 223
Hastings: Meeting of the profession at 103—Address by Medical Secretary, 103—Address by Chairman, 223—Address by Dr. Parry, 223

HEALTH MINISTRY:

Emergency treatment and anaesthetists' fees: Circular letter, 97, 99
Fees of doctors called in by midwives, 12
Insurance practitioners and tuberculosis reports, 201
Medical profession's opinion on questions of policy, 42
Mileage returns (1921), 184
National Insurance business. *See* Insurance
Paying patients in Poor Law infirmaries: Policy *re*, 93—Deputation, 159, 166
Scottish Consultative Council's report, 193

HELM, W. H.: Mutual aid schemes, 14
Hertfordshire (East) Division:—A. P. Giles: Pessaries *versus* operation in treatment of displacements, 102
Hertfordshire (West) Division: New medical record cards, 26
Hertfordshire Panel Committee: Hints for insurance practitioners, 184
HOBSON, William: The new system of medical records 39
Holborn Division: Joint meeting with Westminster Division, 186—National health and the practitioner (G. F. Buchan), 186
Home Office regulations as to dangerous drugs, 25
Hospital, Bradford Municipal: Report of Advisory Committee, 91
Hospital, Wellhouse, Barnet, 81
Hospitals Committee: Payment of members of staffs of voluntary hospitals, 21—Conference of Representatives of Medical Staffs of Voluntary Hospitals, 22—Utilization of Poor Law hospitals, 22
Hospitals and insured patients, 163
Hospitals, Poor Law, and civil needs, 25
Hospitals, voluntary: Conference of Representatives of Medical Staffs, 1, 25, 50—Conservation of the voluntary principle, 1—Subsidies from rates and the State, 4—Employers' and insurance companies' contributions, 4—Contributions from patients, 5—National health insurance patients, 6—Patients of various classes, 6—Attitude of medical staffs as regards paying patients, 6—Future procedure, 7—Conference in Scotland, 25, 50

Huddersfield Division: Address by Medical Secretary, 178

I.

Indian Medical Service, 16, 19, 35, 48, 67, 75, 96, 104, 164, 188, 227—New scale of pay, 8, 93—Civil Branch, 50, 85
Infirmaries, Poor Law, paying patients in, 93, 159, 166
Inquests, payment of travelling expenses in connexion with, 229

Insurance, National:

Anaesthetist's fees in insurance practice, 97, 99
Charges of fraud in insurance practice (J. T. Godfrey), 83
Chemists' hours, 207
Conference of representatives of Panel Committees (Group F) at Birmingham, 51
CORRESPONDENCE:
Anaesthetist's fees in insurance practice, 171, 187, 202
"Availability" in emergency cases, 103
Central Insurance Defence Fund, 28, 32
Curt warning, 33
Dental anaesthetics, insurance records, 95
Dental Bill and insurance practice, 84
Dental treatment by insurance practitioners, 103
Dextro-filing case, 34, 40
Drugs, Dangerous, Regulations, 46
Drugs, supply of in rural areas, 23
Envelopes and cards, 88
Evening surgery, 33, 47
Fees for doctors called in by midwives, 34
Hospital treatment of insured persons, 226
London Panel Committee, 14
Macedonia, Dr., mission of to South Africa, 202, 226
Medical benefit, 27, 47
Medical Guild on the Interim Report of the Scottish Consultative Council, 32
Medical record cards, 14, 18, 23, 27, 34, 44, 45, 66, 75, 84
Medical records in courts of law, 18—In Scotland, 46

Insurance, National (continued):

Medical service scheme for Scotland, 195
Mileage under the Insurance Acts, 163
Mileage records, 33
Motor taxation, the new, 34
Mutual aid schemes, 14
National health and the practitioner, 203
Overlapping ministries, 33
Panel Committees election, 202
Proposed opportunities for affiliating bodies concerned with allied sciences, 171
Regional medical officers, 80
Remuneration, 195
Dispensing in rural areas, 97
Distribution Committee for central and mileage pools, 10, 32, 42
District medical officers for Scotland, 74
Emergency treatment by insurance practitioners, 97, 99
Expenditure and income statistics, 22
Fees for Scottish practitioners called in by midwives, 185
Funds, distribution of, 10, 32, 42
Hospitals and insured patients, 163
Index registers, inflation of, 77
Inquiry into an insurance practitioner's conduct, 15
Insured persons in hospitals, treatment of, 207
Insurance practitioners, hints for, 184
Insurance practitioners and tuberculosis reports, Ministry of Health Memorandum, 201
Medical aid institutions, improved, application for extension of area, 17, 21
Medical record cards, 10, 12, 32, 41—Statement by Ministry of Health, 13—In Scotland, 32—Memorandum, 41
Mileage returns (1921), 184
Nursing schemes for insured persons, 207
Sanatorium benefit in Scotland, 23
Unemployment Insurance Act and doctors' domestic servants, 21, 41

Insurance Acts Committee: Deputation to Ministry of Health, 8—Position of, 227
Inverness County Education Authority and medical inspection of school children, 206
Inverness Division: Report of council *re* federation, 207—Annual report of council, 207
Isle of Ely Division: Medical representation in Parliament, 185—Fees for police calls, 185—Question of federation, 186—Representation of Panel Committees, 186

J.

JONES, J. C.: The new system of medical records, 66—Dental treatment by insurance practitioners, 103—Mileage under the Insurance Acts, 163
JONES, W. B.: Insurance medical records, 14
Jurors, women, exemption of, 165
Jurywoman, refusal of a medical certificate on behalf of, 81
"Juveniles" and contract rates, 8

K.

Kensington Division: Annual meeting, 223
Kent Branch: Annual report, 207—Average attendance, 207—Experiences in a casualty clearing station, 207
Kent County Local Medical and Panel Committee: Resolutions relating to Insurance Medical Committees, 215—Emergency treatment and anaesthetists' fees, 215
KINGDON, Clement Thomas Cory, penal case of, 212

L.

Lancashire and Cheshire Branch: A correction *re* Dr. Walter Stansfield, 233
Lancaster Division: Dangerous Drugs Act, 64
LANGDALE-SMITH, H. G.: A curt warning, 33
Leeds Division: Address by Medical Secretary, 178
LEWIS, W. H.: Regional medical officers, 80
Lewisham Division: Election of officers, 43—Adoption of organization and ethical rules, 43—Provident scheme for hospitals, 179—Report of Consultative Council, 179—Municipal clinics, 179
LILLEY, E. Lewis: Mutual aid schemes, 14
Lincoln, North, Division: Address by Medical Secretary, 233
LIVINGSTON, George R.: Medical records in Scotland, 46
LOCKETT, T. Wood: Insurance medical records, 45—Anaesthetists' fees in insurance practice, 187
London, suggested medical provident scheme for, 161
London County Insurance Committee: Remuneration of medical practitioners, 35—Limitation of practitioners' fees, 35—Surgery accommodation, 35—Rescriptions, 35—Medical records, 35, 179—Scale of fees under "own arrangements," 66—Correction of practitioners' lists, 67—Change of address notification, 95—Lock-up surgeries, 95—

Range of medical service, 95, 179—Women practitioners and male insured persons, 179—Sanatorium benefits, 179

London County Panel Committee: Correspondence on, 14—Record cards, 34, 67, 89—Complaints against practitioners, 35—Service of a second practitioner, 67—Dangerous Drugs Regulations, 67—Medical records, 89—Surgery and waiting-room accommodation, 95—Reconstitution scheme, 95—Post-graduate courses, 103—Chemists' hours of service, 103, 179—Annual dinner, 163—Excessive prescribing, 235—Limitation of lists, 235—Payment for emergency treatment, 235

LYTH, J. C.: Insurance medical records, 15

M.

MCCULLOCH, J. Duff: London Panel Committee, 14

MACDONALD, Dr.: Mission to South Africa, 69, 70, 165, 202, 226—Presentation to, 221, 230, 233

MACKENZIE, Eneas K.: Insurance medical records, 23

MACKENZIE, Ronald P.: Dr. Macdonald's mission to South Africa, 202

Malaya Branch: A correction re salaries of practitioners in Government service, 50—Control of rice and beri-beri, 74—Conference re prevention of venereal diseases, 83

MANSON, J. S.: The new system of medical records, 66

Marylebone Division: Election of Representatives, 11, 198—Multiple door plates, 11—Treatment of private patients in hospitals in the United States of America and Canada, 83—Annual meeting, 198—Annual reports, 198—Question of federation, 198—National Provident Scheme for Hospital and Allied Medical Services, 198

Maternity and child welfare, 30

Medical aid institutions. *See* Insurance

Medical certificate on behalf of a jurywoman, refusal of, 81

Medical officers of health, security of tenure of, 85, 233

Medical profession and questions of policy, means of obtaining the collective opinion of, 42—Deputation to Minister of Health, 42—Memorandum of British Medical Association, 42

Medical provident scheme, suggested organization for London, 161

Medical registration, 31

Medical-Political Committee, work of, 72

METCALFE, Brian B.: Record cards, 27

Metropolitan Counties Branch: Medical provident scheme for London, 161

Mileage for coroners' inquests, 54

Mileage fees for pension referees, 93

MORGAN, R. W.: The new system of medical records, 75

Municipal clinics and the private practitioner, conference at 429, Strand, 86

MURPHY, H. Howard: Insurance envelopes and cards, 88

MURRELL, Christine: Maternity and child welfare work, 30

N.

NAPIER, Francis: Dr. Macdonald's mission to South Africa, 202

National health and the practitioner (G. F. Buchan), 184

Navy, Royal, medical service of, 8, 15, 19, 24, 35, 40, 47, 67, 75, 80, 84, 92, 95, 100, 104, 163, 179, 187, 196, 203, 213, 227, 235—Admiralty surgeons' fees, 77, 165

Navy, British: Royal Naval Volunteer Reserve, 196, 227

NELSON, Jos.: New record cards, 45

NEWELL, A. G.: "Availability" in emergency cases, 103

Newport (Mon.) Local Medical and Panel Committee: Record cards, 35

New South Wales Branch, 197—Annual report, 197

New Zealand Branch: Annual report, 221

Norfolk, East, Division: District medical officers' salaries, 74—Fees for attendance upon pauper women in confinement, 74

Northampton Division: Annual meeting, 223—Election of officers, 223—Fees under Lunacy and Mental Deficiency Acts, 223

Northumberland, North, Division: Annual report, 64

Nottingham Division: Joint meeting with Nottingham Medico-Chirurgical Society, 73—Address by Medical Secretary, 73—Report of work done by the Division, 83—End of

dispute with the Colliery Field Club, 83—Salary for maternity and child welfare work raised, 83

O.

ORMISTON, George, penal case of, 213

P.

Panel Conference: Deputation from to the Ministry of Health, 8

PAULLEY, J.: Record cards, 27

Paying patients in Poor Law infirmaries: Policy of the Ministry of Health, 93—Deputation to the Minister of Health, 159, 166

PENROSE, Geo. R.: Insurance medical records, 18

Pension referees, mileage fees for, 93

PIKE, J. B.: Insurance medical records, 23

PORTER, Frederick: Medical Service scheme for Scotland, 195

Portsmouth Division: New medical record cards, 26—Dangerous Drugs Regulations, 38, 64

Postal rates, the new, 221, 229

Post-graduate education, 85

Public Health appointment, compensation for loss of, 54

Public Health Committee, work of, 54

Q.

QUINE, Wm. J. Aitken: Insurance medical records, 18

R.

R.A.M.C. officers, present position of, 10

Reigate Division: Discussion on the proposals for federation, 169

Rochdale Division: Report of Consultative Council, 63—Macdonald testimonial, 63—Annual meeting, 102

S.

St. Helens Division: Visit of the Medical Secretary, 26

Salaries of university teachers and professors, 29

Sanatorium benefit. *See* Insurance

School children, medical inspection of, and Inverness County Education Authority, 205

Scotland, medical records in, 32

SCOTT, L. Ferris, appointed Financial Secretary and Business Manager, 184

SCOTT, S. Noy: Record cards, 27

Scottish Board of Health: Sanatorium benefit in Scotland, 23—Constitution of Central Midwives Board for Scotland, 31—District medical officers for Scotland, 74

Scottish Committee: Report of Consultative Council, 42—Scale of fees to practitioners under the Midwives (Scotland) Act, 42—Mileage grant to insurance practitioners, 42—Highlands and Islands Sub-committee, 42—Election of direct representatives, 208

Scottish Consultative Council's report, 193—Views of the Royal College of Physicians of Edinburgh, 193

Serbia, medical books for, 85

SHAW, Lauriston E.: London Panel Committee, 14

Singapore Division: Communication re examinations of King Edward VII Medical School, 179—Annual meeting of the Branch, 179—The febrile phases of syphilis, 179

South-Eastern Counties Division: Annual report, 102—Report of Council to Division re Federation, 102—Scottish Consultative Council's report, 102

Southern Branch: Election of members, 11, 12—Representative's report, 12—Discussion on report of Consultative Council, 12

SPEIRS, John L.: National health and the practitioner, 203

Staffordshire, South, Division: Election of officers, 223—Wolverhampton After-care Committee, appointment to, 223—Annual report of Central Council, 233

STANSFIELD, Walter (of Birkenhead): Correction re report of his death, 233

STRICH, A. Benham: Hospital treatment of insured persons, 226

Stockton Division: Dangerous Drugs Act, 64—Contract rates for attendance on police, 64

Suffolk Branch: Spring meeting, 102—Re financing small Divisions, 102

Suffolk, North, Division: Report of Council on federation question, 98

Suffolk, South, Division: Annual meeting, 186

Suffolk, West, Division: Question of federation, 179—Position of Dr. Fothergill, 179—A. Hope Goese: The clinical diagnosis of cardiac arrhythmia masked by graphic mteods, 179—Tea, 179—Golf competition result, 179

Sunderland Division: Annual meeting, 44

Surrey Branch: Council election, 198—Change of boundaries, 198

T.

Tuberculosis reports and insurance practitioners, Ministry of Health's memorandum, 201. *See also* Insurance

U.

Uganda Branch: Election of Representative to Representative Body, 44—Private practice in the Protectorate, 44—Allowance of M.O.H., 44—Scientific discussions, 44—Temporary medical officers' appointments, 44—Medical women and Sinhalese doctors unsuitable for the Protectorate, 44—Annual meeting, 102

Ulster Branch: Dangerous Drugs Regulations, 43

Unemployment insurance. *See* Insurance

University teachers' salaries. *See* Salaries

V.

VARTAN, Charles S.: New motor taxation, 34

VICKERS, H.: Medical record cards, 45

Ward Branch: Election of new Branch Council, 19—Revision of rules, 19—Parliamentary representative, 19—Branch Honorary Secretary, 19—Post-graduate classes, 19

W.

Wales, South, and Monmouthshire Branch: Annual meeting, 207—Presidential address, 207—Clinical meeting and exhibition of x-ray photographs, 207—Social meeting, 207

WARD, Gordon: Anaesthetist's fees in insurance practice, 171

Warrington Division: Annual dinner, 31

Warwickshire Local Medical and Panel Committee: Co-operation with Coventry, 35—Medical records, 35—Accounts submitted by Insurance Committee, 35—"Vague" certificates, 35

WELSH, Robert A.: Mileage records, 33—Medical benefit, 47

Westminster Division: Joint meeting with Holborn Division, 185—National health and the practitioner (G. F. Buchan), 186

WIGHTMAN, C. F.: Evening surgery, 33

Willesden Division: Rates for contract work, 11—Local Health Council, 11—Medical officer of health's report, 11—Maternity and child welfare work, 30—Staffing of school treatment clinic scheme, 63—Future pooling of medical and allied services, 64—Pooling of the existing hospital accommodation, 64—Dangerous Drugs Act, 88—Medical inspection and treatment of school children, 88—Practitioners' mutual help scheme, 88—Clinical meetings and a medical club, 88—Clinical work of the Division, 88—Central Council election, 88—Annual meeting, 234

WILLIAMS, Sir Dawson, awarded the Gold Medal of the Association, 184

WILLIAMS, F. S.: Insurance medical records, 23

Wiltshire Branch: Annual meeting, 198—County laboratory, 198—Election of officers, 198—Council election, 198—Post-graduate lectures, 198—Voluntary Hospitals Association, 198

Witwatersrand Branch: Presidential address, 165—Visit of Dr. J. A. Macdonald, 165

Wolverhampton Panel Committee: Letter from London Panel Committee, 35—Confidence in Insurance Acts Committee of British Medical Association, 35

Women jurors. *See* Jurors

Worcestershire and Herefordshire Branch: Differential diagnosis of acute abdominal conditions from a clinical standpoint (P. L. Daniel), 198—Tea, 198—Exhibition of cases, 198—Vote of thanks, 198

Workmen's Compensation Act, certification under, 54

Z.

Zanzibar Branch: Demonstration of cases, 193

SUPPLEMENT

TO THE

BRITISH MEDICAL JOURNAL.

LONDON: SATURDAY, JANUARY 1st, 1921.

CONTENTS.

	PAGE		PAGE
CONFERENCE OF REPRESENTATIVES OF MEDICAL STAFFS OF VOLUNTARY HOSPITALS.		BRITISH MEDICAL ASSOCIATION.	
Financial Position of Voluntary Hospitals	1	CURRENT NOTICES:	
CONSERVATION OF THE VOLUNTARY PRINCIPLE	1	THE I.M.S. AND THE NEW SCALE OF PAY	3
SUBSIDIES FROM RATES AND THE STATE	4	DEPUTATION FROM THE PANEL CONFERENCE TO THE MINISTRY OF HEALTH	8
EMPLOYERS AND INSURANCE COMPANIES' CONTRIBUTIONS	4	"JUVENILES" AND CONTRACT RATES	8
CONTRIBUTIONS FROM PATIENTS	5	ASSOCIATION NOTICES	3
THE CONTRIBUTORY METHOD OF SUBSCRIPTION	5	ASSOCIATION INTELLIGENCE AND DIARY	8
NATIONAL HEALTH INSURANCE PATIENTS	6	NAVAL AND MILITARY APPOINTMENTS	3
PATIENTS OF VARIOUS CLASSES	6	DIARY OF SOCIETIES AND LECTURES	3
ATTITUDE OF MEDICAL STAFFS AS REGARDS PAYING PATIENTS	6	APPOINTMENTS	3
FUTURE PROCEDURE	7	BIRTHS, MARRIAGES, AND DEATHS	3

CONFERENCE OF REPRESENTATIVES OF MEDICAL STAFFS OF VOLUNTARY HOSPITALS.

London, Tuesday, December 21st, 1920.

A CONFERENCE of representatives of the medical staffs of voluntary hospitals of England and Wales, convened by the British Medical Association, was held in the Barnes Hall of the Royal Society of Medicine, 1, Wimpole Street, W., on December 21st, 1920. The purpose of the Conference was to discuss the situation created by the decision of the Minister of Health to appoint a small committee "to inquire into and report upon the financial position of the voluntary hospitals throughout the country, and to make recommendations."

The chair was taken by Sir JAMES GALLOWAY, K.B.E., senior physician, Charing Cross Hospital, and twenty-seven principal London hospitals and seventy-one provincial hospitals were represented, in almost every case by both a physician and a surgeon from their staffs. Members of the Hospitals Committee of the British Medical Association and the Chairman of Council (Dr. R. A. Bolam) were also present.

The CHAIRMAN, in opening the proceedings, said that many things which were happening affected the position of the medical staffs of voluntary hospitals, and on the initiative of the Chairman of Council of the British Medical Association it was thought desirable to bring representatives of such staffs together for the interchange of views and the passing of resolutions. Many hospital men in London were ignorant of the conditions of hospital practice in industrial areas, while the men in such areas were not as familiar as they were in London and other places with the conditions of hospitals serving large residential populations. Everything was to be gained by this, the first real interchange of hospital staff opinion. Many of the motions on the agenda which had been received from the staffs of various hospitals overlapped, and it had been a matter of some difficulty to select those most suitable for broad discussions; but he had endeavoured to make such a selection, and he hoped the representatives would support him in what was necessarily a somewhat arbitrary procedure. He thought also that it would be a great pity if the Conference were left without any sequel, and therefore he would at the proper time ask the representatives to nominate some body which might be responsible for continuing its work.

THE FINANCIAL POSITION OF VOLUNTARY HOSPITALS.

The Conference then, on the Chairman's motion, proceeded to consider what was the general opinion of hospital

staffs as to how the present financial difficulties of voluntary hospitals should be met.

The Conservation of the Voluntary Principle.

MR. BISHOP HARMAN (Chairman, Hospitals Committee, British Medical Association) moved:

That this Conference of the staffs of voluntary hospitals called by the British Medical Association desires to record its belief that the voluntary method of maintenance and staffing of the voluntary hospitals of the country is to the advantage of the public, of medical science, and of the medical profession, and that it should be maintained.

He wished the venerable President of the Association (Sir Clifford Allbutt) could have been present to move this resolution, because of his unique knowledge of the voluntary hospitals, and of the work he had done on their behalf. All those present had been bred and apprenticed in the service of the voluntary hospitals. They all knew the work done by those hospitals and believed in them. Times were changing, and there were many difficulties, but whatever modification the voluntary principle might undergo they were convinced that something like what they knew as the voluntary principle was necessary for the maintenance of this type of institution, and in the best interests both of the profession and the general public. When they lauded the voluntary hospitals they did not for a moment belittle the work done by the great State institutions. They recognized that work ungrudgingly. Yet they felt that there was something in the spirit of the voluntary hospitals which they could not afford to lose. Freedom was a necessary condition to the gathering of the best fruits of medical experience and practice. The voluntary hospitals had grown as time and place and circumstances directed, with nothing forced or artificial about them. This spontaneity which characterized them was of great advantage alike to the public and to medical science. He thought he spoke for most of those present when he said that they believed in the voluntary system so completely that they would like, if they could, to have the voluntary hospital of the old days, when all expenditure was paid by the charitable, when all the patients were necessitous and all the doctors gave their free service. That might not be possible now, but they wanted the nearest approximation to it that could be secured. This fine spirit of independence was of the greatest advantage to their professional life, and what advantaged medicine advantaged the public. There were other ways in which the public benefited. It would be a

positive loss to the public if there were no charities to which it could contribute of its surplus funds. Again, there were many most capable people in this country who exercised a useful influence in communal affairs, not by being elected to a public body, but by giving their services freely in the management of these hospitals. It would be a loss to the State if all the voluntary hospitals were gathered within the precise bounds of State activity and nothing was left to the voluntary action of these friendly semi-public agencies. Within recent years a member of the profession, Dr. Maudsley, had left a large sum for the founding of a voluntary hospital in that branch of medicine which was most completely covered by State service—the treatment of mental disease. Everyone knew how excellent were the State institutions for this purpose, yet Dr. Maudsley had felt that something was wanting, and the result was the great hospital now standing at Denmark Hill. That was one instance of the tenacious belief of the profession in this sense of freedom which could only be maintained within the voluntary system.

Sir HENRY DAVY (Royal Devon and Exeter Hospital) seconded the motion. The staff of his hospital was extremely anxious that the voluntary principle should be maintained as far as possible, and had asked its representatives to express its views strongly on the subject. Not only did the staff believe firmly in the voluntary principle, but also in its practicability, at least in a very large number of cases, in the existing situation. His was not a very large hospital (180 beds): it had a subscription list of about £5,000 and endowments yielding about £3,000 a year, but although there had been financial difficulties the way out was now being seen. A wage limit of £3 per week was instituted, and any person earning a wage above this limit could not be received into the hospital except by special leave of the Committee. The Hospital Committee elected once or twice a year a subcommittee of twelve to deal with admissions, and an inquiry officer was appointed to discover exactly the circumstances of each patient and to recommend what charge should be made. The maximum charge per week for an in-patient was 10s., but below this it varied according to what the responsible body thought the person could pay, and in necessitous cases no charge was made at all. During the last three or four months the hospital had had no difficulty in getting as much as from 250 to £60 a week from patients, and that, he believed, was going to save the position so far as finance was concerned. The hospital had also a method whereby persons above the wage limit could be received. If a doctor in the district had a case which required surgical operation or special medical treatment, he would write to one of the staff, and that member of the staff would place the matter before the special subcommittee. On admission this patient was charged whatever was thought advisable by the members of the staff under whose care he was going. The money received, which was paid into the hospital, was divided into two portions, half going to the hospital itself, and the other half to members of the staff. A number of State patients were also received, for whom the hospital was paid. In these ways the voluntary system, with all its freedom and helpfulness, was safeguarded, and the wishes of the profession also were being met. He believed that a very large number of hospitals which were now in great difficulty would be able to carry on if a similar plan were adopted. The out-patients were asked to contribute 1s. towards the cost of their medicine, and to pay the actual cost of their dressings according to the prices ruled by contract in the hospital, and 1s. also was charged for treatment in the electrical department. The alternative to carrying on a hospital in this manner was to let it be put on the rates.

Sir HAMILTON BALLANCE (Norfolk and Norwich Hospital) said that Sir Henry Davy had certainly told the Conference how a hospital could be kept going, but not on the voluntary system. Most hospitals at the present time were receiving contributions in respect of pensioners; many were receiving contributions from local authorities in respect of school children, and many were receiving money from workmen who contributed weekly to a fund organized for the purpose. The first two of these at least were not really voluntary contributions; they came either from the State or from the local municipal funds. Mr. Harman's motion would, if logically carried out, exclude these two classes of contributions, for they could not be accepted under a really voluntarily supported system. With regard to the staff, when pensioners were taken into a hospital the staff commonly received a proportion of the 9s. a day paid in respect of these pensioners. Some of the motions before the Conference put forward the view that the staff ought to have a portion of the workmen's contributory fund also. But this made it impossible to call

the staffs "honorary." If a local authority chose to pay three guineas a week for the maintenance of a patient, he did not see why, after the hospital had fully met its expenses in connexion with that patient, a sum should not be handed over to the staff, if the staff chose, for medical services, but in that case the staff must not regard itself as honorary. He did not like the idea of the staff taking a proportion of the funds paid to the hospital, whether for pensioners sent by the State, or for children sent by the local Education Committee, or for workmen sent through a workmen's contributory fund, unless the hospital had been fully reimbursed for its expenses in connexion with these cases.

Mr. F. W. COLLINSON (Preston Royal Infirmary) did not think personally that a charge made to local authorities affected their position as members of the staffs of voluntary hospitals. In the institution with which he was connected the method of charging patients had been in practice for some years, and had finally been regularized and defined, and had proved quite successful. The board felt that although the hospital was originally founded for the treatment of the necessitous, there was a large class of people who could not be called necessitous but yet were unable to meet the expenses of illness in their own homes or in private nursing homes. In these cases it was held to be perfectly justifiable to meet the people half way, and to use to a certain extent the funds of a voluntary hospital for helping them out of a very great difficulty. The people who felt the full force of such misfortunes were the middle classes. The professional man or shopkeeper in a small way could not afford to pay for an operation at home, and his domestic arrangements often precluded it; in helping such a person the infirmary board did not regard itself as departing from the voluntary principle. Apportioning a share of the funds for the members of the staff was satisfactory, in that it gave them the feeling that they were being compensated to a certain extent for the number of hours they spent in hospital, and, moreover, that they were not being "done" by persons able to pay for their services. Arrangements were now being made in Preston for using contributory methods, and an energetic secretary was trying to whip up the workpeople to give 2d. a week, which would yield £10,000 a year, and would largely help the hospital out of its difficulties. Thirty years ago a large proportion of operations were done outside the infirmary; to-day it was the smaller proportion which were done outside, and if the young surgeons could not remunerate themselves to some extent for the many hours they gave to the hospitals it would be very hard upon them. The institution still remained a voluntary hospital for those unable to pay, and thereby it maintained its original function, for it was for the benefit of those classes that the hospitals were first built. That should not prevent an institution charging when the persons in question could afford to pay. It might seem that the hospital was being turned into a cheap nursing home, but there was no claim upon the hospital for these people to be treated voluntarily.

Dr. ASTLEY CLARKE (Leicester Royal Infirmary) said that his hospital was in an industrial centre, and none of the 350 beds were paying beds; no payment was received for any patient who came in, and yet the hospital was thoroughly solvent. The income was obtained as a result of organization, forethought, and perseverance, and if other hospitals had followed the same policy the position of the voluntary hospitals at the present time would be greatly ameliorated. Roughly speaking, the finance of a hospital should be regarded as falling within two categories: capital expenditure and annual upkeep. The former should represent the gifts of employers, large philanthropic givers, and also legacies; the maintenance of the hospital, on the other hand, should be the primary concern of the people who stood to benefit. In Leicester certain special efforts were made which were only possible in such centres as county boroughs where, unlike London, local patriotism was strong. The treasurer went round to the great manufacturers and asked for a handsome annual subscription, and of that subscription he guaranteed to pay three-fourths to capital for future extensions, so that the employer would not again be approached for big sums when next the hospital developed. In the surrounding villages also special efforts were organized. In the speaker's view the primary meaning of a voluntary hospital system was a system free from bureaucracy.

Mr. W. S. DICKIE (North Riding Infirmary) said that the financial problem—which offered the only reason for departing from the voluntary system—did not arise in an acute form in the hospitals for which he spoke. The annual expenditure was fairly well met by subscriptions, but four-fifths of the funds came by way of workmen's contributions. For that reason those who had sent him to

the Conference were decidedly in favour of the continuance of the voluntary principle. Not that they believed it was necessarily the very best, but it was the one which for the time being answered to the conditions. They could fairly say in his part of Yorkshire that in the near future they would get sufficient to keep the hospitals going on the lines on which such institutions should be run. He was instructed to urge that the voluntary system as applied to the maintenance and staffing of hospitals should be supported.

The CHAIRMAN OF COUNCIL (Dr. Bolam), in order, he said, to clarify the situation, moved an amendment which substituted "administration" for "maintenance and staffing" in Mr. Harman's resolution. The one principle that the mover of the resolution contended for was the voluntary spirit, and that could be maintained by leaving the administration of the hospitals in the hands of the voluntary committees now administering them. This would at once put to the test the feeling of the Conference as to whether the great voluntary hospitals should be handed over to the municipalities or the State, or should remain under the control of those now supervising their work. He took it that the great majority of the representatives were out for the voluntary principle to that extent. (Hear, hear.) The hospitals represented in the Conference fell into several categories from the standpoint of their sources of financial support. Some could very well continue their work on purely voluntary lines, ministering to their patients through their endowments and voluntary subscriptions. Others, in a sense equally prosperous, were at the other extreme in that they ministered to their patients as a result of contributions which came practically from the patients themselves—a different kind of thing altogether, and one which bordered on the provident club or dispensary principle. Others, again, were in an intermediate position, wherein funds to a certain proportion were available for the benefit of the purely indigent, while the greater part came from people who, giving at first in a purely charitable spirit, gave now in the expectation that should illness overtake themselves or their families the hospital ministrations would be available for them. It would be well to have a resolution whose terms could be supported by the representatives of all these different classes of hospitals.

Sir HAMILTON BALLANCE seconded Dr. Bolam's amendment, and the amendment was accepted by Mr. Bishop Harman.

Dr. P. MACDONALD (York County Hospital) opposed the resolution. He did not believe that the voluntary method of maintenance or administration was to the advantage of the public, of the medical profession, or of medical science. Mr. Harman's introductory speech had made two alternating impressions on his mind. The first was that the mover had got hold of Wells's time machine and travelled back a century or so, and the next was that in the year 1920 that Conference had had Rip van Winkle coming from mid-Victorian times and addressing them before he was quite awake. These were not mid-Victorian times; they were neo-Georgian times. They were characterized by the insurgence of democracy, intolerance of caste and privilege, and the assertion of equality. What, in the light of these things, was going to be said for the voluntary system? The great mass of the people in this country were to get medical service—the most important thing after food and clothing and housing and the opportunity to work—from charitable sources, either wholly or partially! That was what the great voluntary system proposed. It would not do. The country had been through a war; most people believed that the war was waged to make the world safe for democracy. Much had been said about making a country fit for heroes to live in, and some of the heroes believed it. Did those present really think that these men, having been told what they were told, were going to have this important service given to them as a charity? Perhaps it was a sentimental objection, but the world was ruled by sentiment, and the English people were the most sentimental race on earth, with the possible exception of the Scottish. (Laughter.) But the ease against voluntarism was not all sentiment. There were hard, solid facts to be advanced in opposition. One fact was the number of hospital beds at the disposal of the community under this system. He himself had come to the conclusion that to be adequate the hospital beds must be increased by 200 per cent., and Sir Napier Burnett, in his preliminary survey of hospitals, had since stated that in his opinion the provision of hospital beds, which was now 1 per 1,000 of the population, should be 3 per 1,000 in industrial areas and 1.5 per 1,000 in rural areas. Take the case of Bradford. Bradford had three voluntary hospitals, with a total of 361 beds, serving a population which could not be less than half a million, and

the conditions were so intolerable that a municipal hospital had been established with (on paper) 1,148 beds. The voluntary system was inadequate, and never could be anything else. He believed he was correct in saying that the chairman of the Bradford Royal Infirmary had declared that its deficit was at the rate of £1,000 a month. He asked the Conference, was it going to demand anything less than adequacy? The tragedy was that valuable time was being wasted. The movement away from voluntarism and towards adequacy was at present a gentle stream, and if taken in time a barrage might be put across it, and it might be guided into sluices and made to send its energy through turbines. But if they tried to dam it they would fail; they would only give it a better head, an accelerated pace, so that shortly they would not be able to influence it at all, and it would become a cataract. The time to deal with the matter was now. It was for the Conference to give a lead, and that was why he hoped this resolution would be rejected altogether, and that they would declare that the voluntary system for the provision of hospitals was inadequate and wholly unsatisfactory.

Dr. FRANK RADCLIFFE (Oldham Royal Infirmary) pointed out certain great differences between the Poor Law infirmary and the voluntary hospital. It had to be remembered that in a publicly elected body like a board of guardians there might always be in the minds of some of the members a fear of the poll, and this did not apply in the case of the governors of a voluntary hospital. Those who had had experience of both the State-aided institution and the voluntary hospital knew how many advantages the latter possessed.

Mr. L. P. GAMGEE (Birmingham General Hospital) pointed out that large hospitals treated an enormous number of insured persons, and the Government had a very large fund in respect of insurance, amounting to millions, which was originally allocated for hospital treatment. If, by voting for this resolution, he excluded the present voluntary hospitals from participation in that fund he would regret it, firm believer in the voluntary system though he was.

Dr. T. SANSOME (West Bromwich and District Hospital) said that the point to be borne in mind was the large sum it was necessary to raise to keep the voluntary hospitals going. Probably the hospitals represented in that room were practically in debt to the extent of three millions. It was impossible to-day to run hospitals entirely on the voluntary system, especially as, being the best institutions for the purpose, they were called upon to do so much work for pensioners and others. The three millions of which he had spoken would never be secured from the people to-day, and it would be necessary to go to the Government for help. He would like the hospitals to remain as voluntary as possible, but they would drift hopelessly unless the Government did something for them.

Mr. BISHOP HARMAN, in reply, said that only two objections had been formulated against his resolution, one of them arising out of the interpretation of the word "voluntary," and the other the extreme logical opposition to voluntarism which Dr. Peter Macdonald had offered. The voluntary method as applied to maintenance or administration did not exclude from the hospitals a number of accessory pieces of work undertaken by them on a business basis. The State, for example, came to the voluntary hospitals when it was desired to establish venereal diseases clinics, and asked the hospitals to take over the work in return for State subsidy. Such work was an annex to the hospital, but not necessarily part and parcel of it. The flavour of voluntarism was retained, and, indeed, it was because of that flavour that the voluntary hospitals were sought out by the State or the municipality to perform these special services. (Children's and pensions clinics did not infringe the principle of a voluntary institution. Years ago "voluntary" and "gratis" were interchangeable words, but now they were miles apart. The word "voluntary" conveyed a principle hard to define, yet one which was understood by them all. In education the universities and medical and other schools were voluntary establishments, and yet were largely State aided. As for Dr. Macdonald, the speaker appreciated the logic of his argument. He would not defend voluntarism on logical grounds, but as with illogical people so with an illogical system, it was often very lovable.

Mr. Harman's resolution, with the word "administration" substituted for the words "maintenance and staffing," was then put, and in a meeting which numbered about 150, was carried with four dissentients.

Mr. A. E. MORISON (Durham County Hospital) moved: "That necessitous persons shall continue to be treated free," and this was immediately agreed to, with one dissentient.

Subsidies from Rates.

Mr. BISHOP HARMAN moved:

That it is undesirable that the voluntary hospitals should be subsidized by the local rating authorities, except in so far as payment is made for the examination and the care of patients for whom these authorities are responsible.

This, he said, was a bold challenge to the position taken up by the Government in Clause 11 of the recent Ministry of Health (Miscellaneous Provisions) Bill, which would enable county councils to subsidize local hospitals. The provision was hailed with the warmest enthusiasm in some quarters and met with equally determined opposition in others; ultimately the Minister withdrew part of that clause and agreed to remit the question to a special committee. The speaker did not wish to see the voluntary hospitals in the hands of local councils. When the great State hospitals already in existence were put upon a modern basis one of the conditions of the change would be that the control was taken from the many small authorities now governing them and put into the hands of the larger municipal authorities. With a number of State hospitals having very large accommodation governed by these authorities, were the authorities likely to look with a kindly eye upon voluntary institutions? Such a state of affairs must affect the voluntary hospitals, and almost certainly in some parts of the country would mean their disappearance or incorporation into a State hospital service.

The motion was agreed to, apparently without dissent.

Subsidies from the State.

Mr. BISHOP HARMAN then moved:

That in times of exceptional financial difficulty it is desirable that the central Government should subsidize voluntary hospitals, and that such subsidy in the case of any individual hospital should take the form of a contribution proportional to the income received by the hospital from voluntary and other contributions. The subsidies here proposed should be made through some central hospital fund, such as King Edward's Fund for London or the Red Cross.

He pointed to the parallel of the university grants which were made through and distributed by a committee appointed by the Government. The same method should be followed if the State was to help the hospitals. The principle was not democratic, but it appeared best to serve the purpose.

The CHAIRMAN OF COUNCIL moved an amendment which left out the reference to the ratio of Government contribution to income, and inserted words to the effect that the subsidy should take the form of grants in respect of the training of medical practitioners and nurses or of loans for extending the purposes of the hospital. Dr. Bolam thought that the principle whereby the grant was made proportional to the income of the hospital was very likely to lead to hardship in particular cases. It was a better principle, he contended, to allot a contribution in respect of work done which was capable of assessment. It must be recognized by them all as citizens that the Government was in no position at present to give any exceptional grants, and that it must look to the community in the various centres for the general support of the hospitals to the fullest extent. The grants that came from the Exchequer must necessarily be small, and could be properly given along the lines suggested in his amendment. He had expressly not laid it down by whom the money should be distributed. That was a matter of detail which it was not desirable to pursue at the present moment.

Mr. E. DEANESLY (Wolverhampton and Staffordshire General Hospital) seconded Dr. Bolam's amendment. He thought it highly desirable to include the reasons for which a Government grant was claimed.

Dr. P. MACDONALD hoped that both the mover of the original resolution and the mover of the amendment would content themselves with the mere statement that it was desirable that in times of financial difficulty the central Government should subsidize the voluntary hospitals.

Dr. HUGH BARBER (Derbyshire Royal Infirmary) urged the retention of the final clause of the motion, in which it was suggested that the subsidies should be made through some central hospital fund.

The CHAIRMAN OF COUNCIL pointed out that the grants which already came to hospitals from the State were usually sequestered for special purposes and were not applied to the maintenance and treatment of patients. He was convinced that his amendment was in proper sequence to the resolution already adopted by the Conference, affirming the desirability of maintaining the voluntary system. There was no more subtle drug in the pharmacopoeia than Government aid. If it was desired to maintain the

voluntary system, then Government aid must only be invoked in so far as the institutions were doing national work; that course would stave off the day when these institutions were taken under Government charge entirely.

The CHAIRMAN, in reply to a question, said that the Conference was only framing expressions of opinion for its own guidance and the guidance of whatever body the Conference might appoint to pursue the matter further.

Dr. Bolam's amendment, which Mr. Harman said he could not accept, was put to the Conference and lost by a large majority.

Mr. L. P. GANGE (Birmingham General Hospital) thought it well that the specific form of the Government contribution should be set down in the resolution. Unless this was done voluntary contributions would disappear. If the Government contribution was proportional to the income received from voluntary sources the voluntary subscriber would be encouraged and would continue, but if the Government paid the whole of the deficit then the voluntary subscription would cease.

Mr. MCADAM ECCLES (St. Bartholomew's Hospital) asked whether the Chairman of the Hospitals Committee really intended that the State should subsidize the voluntary hospitals indiscriminately. There were two classes of voluntary hospitals; those which were purely local to certain municipalities, and those which fulfilled a wider function in large centres of population and generally had medical and nursing schools attached to them. It would be better to ask the central Government to subsidize the large hospitals with medical and nursing schools attached, and leave it to the municipalities to subsidize local hospitals with local interests. ("No.")

Mr. HARMAN was not prepared to modify the original motion, nor to look at it in the way Mr. Eccles suggested. It was not desirable that any subsidy should be allocated to a particular hospital; it should only be given to a fund.

Dr. P. MACDONALD proposed, and Mr. L. P. GANGE seconded, that the middle clause of the motion, defining the form of Government contribution, should be left out, but this amendment was lost. A further amendment, proposed by Dr. HASLIP, which deleted the last phrase referring to specific organizations, was carried. The motion as finally agreed to was as follows:

That in times of financial difficulty it is desirable that the central Government should subsidize voluntary hospitals, and that such subsidy in the case of any individual hospital should take the form of a contribution proportional to the income received by the hospital from voluntary and other contributions. The subsidies here proposed should be made through some central hospital fund.

Employers' and Insurance Companies' Contributions.

Mr. BISHOP HARMAN moved:

That greatly extended support for voluntary hospitals should be sought from employers and insurance companies, seeing that they benefit largely, both directly and indirectly, by the services of the voluntary hospitals.

All those whose practice was in industrial areas knew that, despite the large number of working people coming to the hospitals, there was no proportionate recognition by the employers who undoubtedly benefited by the rapid treatment of their workpeople. The insurance companies now did an enormous business in connexion with the Employers' Liability Acts, and these companies also benefited very largely by the services of the voluntary hospitals. In the old days when insurance companies came into being to cover fire risk, they themselves furnished the first fire brigades. It became necessary at length for the communities to have their own fire brigades, but the London insurance companies still maintained their salvage corps which did valuable work in saving material. That principle might have been followed by the insurance companies in their business in connexion with the employers' liability; they had not done it in this country, though it had been done in America.

Mr. A. E. MORISON (Durham County Hospital and Sunderland Royal Infirmary) said that a very large amount of work was done both for insurance companies and employers without payment either to hospital or surgeon. The representative of a leading insurance company told him that if the insurance companies contributed, the employers would at once reduce their capitation grant for accidents. Before the war the speaker was looking after compensation work in his area, where there was a large colliery company, with three mines and employing ten thousand men. A cottage hospital, fully equipped, was looked after by the local practitioners, and in certain cases of accidents and operations he was called in. For three years he did every operation on every patient who came under the Workmen's Compensation

Act: for this he received a salary. The employers admitted that he saved them something like £4,000 a year in compensation by doing this. It was certainly incumbent upon employers to help the hospitals. At the same time, many of the large works in his area were now contributing at the rate of £1 for every £1,000 paid in wages, so that subscriptions, which in the case of one firm used to be about £20, rose to as much as £250 a year.

Mr. A. J. COUZENS (Queen Mary's Hospital for the East End) suggested that the discussion was waste of time. As medical men, had they anything to do with the methods by which funds were raised?

Dr. G. THOMSON (King Edward Memorial Hospital, Ealing) pointed out that it was comparatively easy to secure contributions in large industrial areas where there was a certain amount of local patriotism, but conditions were very different in London. So far as London was concerned, he thought that this could be only a pious resolution. It could only be put into effect through some central fund, which could allocate the money to hospitals scattered over a wide area.

Dr. A. J. H. ILES (Taunton and Somerset Hospital) suggested that the contributions from the insurance companies should be in the form of payment for work done. He did not think they could expect to get greatly extended funds from insurance companies in the ordinary way, but such companies should pay for work actually done on their behalf. He gave an instance of how this method had been applied successfully.

Dr. G. E. HASLIP (Hospitals Committee) urged that this was a pious resolution. The insurance companies would allow the voluntary hospitals to go on doing their work voluntarily for as long as they were willing to do so. This insurance question really involved a big principle affecting the whole situation. Directly a workman was receiving compensation for his accident he was no longer one of the necessitous poor for whom the voluntary hospitals were started.

Dr. E. T. COLLINS (King Edward VII's Hospital, Cardiff) disagreed with the last speaker. Many of those present at the Conference, he said, were members of boards of management and house committees, and if this resolution was carried it would enable the representatives who sat on such bodies to bring the matter to the notice of their colleagues as the expression of the opinion of a very large gathering of hospital physicians and surgeons. He agreed that as members of the medical staff it was no part of their duty to consider how money was to be raised, but as members of boards and committees it would be of very great value to have such a resolution.

Mr. W. S. DICKIE (North Riding Infirmary), while agreeing with the motion so far as it related to employers, thought that a will-o'-the-wisp was being pursued so far as it related to insurance companies. The insurance company was a business association, and was in the habit of claiming that hospital treatment was of no value to it, or might even in certain conceivable circumstances increase its expenditure instead of lessening it.

The resolution was carried.

Contributions from Patients.

Dr. J. R. ROBERTSON and Mr. F. G. RALPHS (both Ashton-under-Lyne Infirmary) respectively proposed and seconded:

That every patient of a voluntary hospital who is not a necessitous person should make a weekly contribution towards the cost of maintenance.

Dr. HASLIP did not think the supporters of the voluntary system quite appreciated what they were voting upon. How much did they think they were going to get out of the working man when he was in hospital and economically in a low state? Unless he was an insured person he could not usually contribute to the hospital at all. In that case he came into the category of necessitous persons. Very well. But if he was an insured person, from whom must the contribution come? From the Government? In that case the hospitals would be receiving Government contributions.

The CHAIRMAN OF COUNCIL, having elicited from the mover of the resolution that it was intended to propose that the patient should make a weekly contribution during the time he was in hospital, said that he thought the motion would secure a wider acceptance if the term "weekly" were deleted. It would then be possible to discuss whether the payment should be made while the patient was actually lying ill or whether a system of voluntary insurance should be encouraged.

Mr. E. DEANESLY (Wolverhampton and Staffordshire General Hospital) said that every hospital which had a

workmen's contribution fund would object to this principle. In some hospitals a weekly contribution might be a useful expedient, but to press it generally would be a mistake.

Dr. J. G. CLEGG (Manchester Royal Eye Infirmary) suggested that instead of "weekly contribution" the words "a contribution during treatment" should be used, and this would include both out-patients and in-patients.

Dr. ASTLEY (CLARKE Leicester) said that workmen who contributed to the hospitals by way of a workmen's fund would have nothing to do with paying beds in hospitals. They regarded admission as a right, and would not have almoners. He was sure that such men would withdraw their subscriptions absolutely if the principle of payment were insisted on.

Mr. J. L. JOYCE (Royal Berkshire Hospital, Reading) said that in his own hospital every patient had to pay 2s. a day for maintenance unless he could prove that he belonged to the necessitous poor, and 70 per cent. of the patients paid this contribution gladly. For a long time past it had been the custom, when patients left the hospital, to ask them to make a voluntary contribution, and when this system of payment for maintenance was started it was assumed that these voluntary contributions would diminish; on the contrary, they went up, and the workman's subscriptions to the hospital had increased also.

Dr. P. MACDONALD pleaded that if they were going to retain charity it should be retained completely and logically. He objected strongly to semi-charity and oblique charity.

Mr. E. H. E. STACK (Bristol Royal Infirmary) put it that the question was whether they were to get subscriptions from the well or the ill. That was the definite point to settle. It would certainly be wrong to mix the two. He suggested that a phrase might be inserted in the resolution: "Every patient who is not a regular subscriber," etc.

Dr. ROBERTSON, while willing to withdraw the word "weekly" in his motion, wanted to make it clear that the payment was for treatment, with or without maintenance.

The CHAIRMAN OF COUNCIL pointed out that in the case of certain hospitals this would mean that the funds forthcoming by weekly contributions from workmen, which now were in the hands of hospital governors, would be retained by representatives of workmen and paid out weekly for the individuals who happened to be in hospital. There were in industrial centres numbers of hospitals where 50 per cent. or more of the income—in some cases 90 per cent.—was in the form of weekly contributions from the workpeople, and now it was proposed to ask that the workmen as patients should pay during illness.

The CHAIRMAN thought it would be possible to make special provision to meet cases in which workmen's contributions were already forthcoming.

The resolution was carried in this form:

That every patient of a voluntary hospital who is not a necessitous person should make a contribution during treatment towards the cost of maintenance.

The Contributory Method of Subscription.

Mr. A. E. MORISON moved, on behalf of Durham County Hospital, a resolution affirming that the contributory method of subscription was the only one possible under the conditions obtaining in the North of England. In view, however, of the increased maintenance and other costs, the contributory rates paid by workmen should be materially increased. This, he said, was the feeling of hospital staffs in County Durham, a very populous industrial area. For something like twenty-five years it had been the custom among the workmen to contribute on the provident basis. At first, of course, the hospitals were regarded as charities; that view had now passed away, and the workmen resented any such suggestion, having regard to the payment by them of large donations. The staffs had been constantly pointing out to them that the only charitable part of the undertaking was the work of the medical and nursing staff. In most of the collieries and other works the workers were asked to contribute a certain sum per week, and all the workpeople not contributing in any other way were now being asked to set aside 3d. a week for the infirmary. Last year £10,000, or about one-third of the cost of upkeep, was received by way of the workmen's contributions. Before the war the men contributed about £8,000 a year—rather more than half the total contributions to the infirmary. The minimum of 3d. a week now asked for, which had already secured a good response, meant, in the case of seven works, an increase of subscription during the first eleven months of 1920 of £6,000, and it was expected that the workmen's contributions for the whole year would amount to something like £21,000. Another method was under consideration; this was for various collieries and other works to hold back the money

collected and send the hospital a capitation fee per week for every patient admitted from the area. Many collieries and works contributed exceedingly well, others very badly, only at the rate of 3d. per man per week, and it was desired to bring a little pressure of public opinion to bear upon these latter.

Dr. FRANK RADCLIFFE seconded the motion. Speaking of the Royal Infirmary, Oldham, he said that in 1910 the annual subscriptions amounted to £2,052, and in 1919 to £3,538, an increase of 75 per cent. There was still some charity left. The income from endowments in 1910 was £2,323, and in 1919 £4,831, an increase of more than 100 per cent. From the classes which might be called either capitalist or provident they had got an increased subscription of about 80 per cent. The figures for the Hospital Saturday Collection, a purely working-class affair, were in 1910 £2,492, and in 1919 £2,840. The workpeople of Oldham and their trade unions also had seen clearly that they ought to contribute more. A penny a head per week from the workmen in Oldham would put the Royal Infirmary in clover.

Mr. W. S. DICKIE and others supported the motion, and in answer to a question Mr. MORISON said that his motion, of course, aimed at voluntary contributions from the workpeople, but moral pressure should not be lost sight of.

Sir HAMILTON BALLANCE remarked that, of course, Mr. Morison under this scheme did not expect a working man to go to the hospital when he sprained his ankle, but only to go there for the treatment which the hospital was specially designed to give. Did he include the wives and families of the workmen?

Mr. MORISON replied in the affirmative.

Sir HAMILTON BALLANCE: Has the hospital any trouble with general practitioners in Mr. Morison's area?

Mr. MORISON: No. Most of our cases are sent by general practitioners.

Dr. HASLIP said that he calculated that if 3d. a week could be obtained from every insured person the hospitals would have a revenue of over eight millions a year.

After further discussion it was agreed that the Durham motion should be accepted as a rider to the Ashton-under-Lyne motion already carried, and that the motion should read as follows:

That every patient of a voluntary hospital who is not a necessitous person should make a contribution, during treatment, towards the cost of maintenance, unless the contributory method of subscription, regarded as essential in industrial areas, is adopted. In view, however, of the increased cost of maintenance this Conference considers that the contributory rates paid by workmen should be materially increased.

In this form it was adopted.

National Health Insurance Patients.

Dr. JOHN RUSSELL (North Staffordshire Infirmary) moved that in the case of persons insured under the National Insurance Acts payment should be made to the hospital for treatment which could not be obtained from the panel doctor in accordance with his agreement under the Acts. He wished to emphasize the feeling in North Staffordshire in favour of the voluntary system; but they considered that if the State made itself responsible for the treatment of any part of the community then a payment should be made by the State to the hospitals. How should this payment be made? At the outset of national insurance the people affected were promised that they should have opportunities of hospital consultation and treatment, but this had never been given under the Acts, simply because such facilities were already provided by the voluntary hospitals. In an area such as North Staffordshire 40 per cent. of the in-patients and 26 per cent. of the out-patients were insured persons. The latter percentage was very much higher until recently, when a system was adopted whereby insured people were examined by the surgeon or physician in charge of the out-patient department and in suitable cases were referred back to their own insurance practitioner for treatment, with a letter from the member of the honorary staff. This had materially diminished the number of out-patients on the books of the infirmary, and had been accomplished without any friction between the insurance practitioners and the infirmary staff.

Mr. E. DEANESLY, in supporting the motion, said that there was only one source from which it would be possible to look for a steady flow of funds for the hospital in future—namely, insurance. For years the hospitals had been doing the work for which national insurance was started, relieving the disabilities of the people who eventually came within national insurance, and keeping workmen in a fit state of health to do their work. It would be necessary

to add to the insurance fund a hospital benefit—say another 3d. a week—derived from both employer and insured person. This question was one of the most crucial they had to discuss.

Dr. F. RADCLIFFE questioned whether it was possible for them to get a penny from Insurance Acts funds without a new Act of Parliament. Moreover, immediately the Ministry of Health gave any money towards the treatment of insured persons in hospital, inspectors would be sent down, and there would be interference with the freedom of hospital practice.

Dr. A. J. CLEVELAND (Norfolk and Norwich Hospital) asked how, if the insurance funds were to be drawn upon for hospital treatment, the hospitals could expect to carry on the workmen's contribution schemes. The workmen could not be expected to continue their weekly pence for the support and maintenance of themselves or their fellows in hospital when the insurance authorities were asked to pay for them in hospital also.

Mr. W. S. DICKIE asked whether the payment to the hospital was to be for treatment which the insurance practitioner had neglected to give, or for treatment which presumably could not properly be undertaken, consistently with the best interests of the patient, by a general practitioner of ordinary competence and skill.

The CHAIRMAN OF COUNCIL wanted to know by whom this payment was to be made. The mover of the resolution had left that point vague. Was it to be made by the insured person during his term of sickness or, by means of a contributory system, during health? or was it to be from an insurance fund formed in part by the insured person and in part by the State, or by the State entirely? There was not much prospect of a subvention from the funds of the State for this purpose, nor was it likely that any Government at present would undertake to persuade the working classes that they must contribute some pence more a week towards the cost of hospital treatment.

Mr. R. J. FERGUSON (Kent and Canterbury Hospital) opposed the resolution on the ground of its effects upon insurance practice and the various complications it would introduce.

After some further discussion, Dr. RUSSELL agreed to withdraw the resolution. The CHAIRMAN said that the position of the insured person would doubtless be considered by the Hospitals Committee.

Patients of Various Classes.

Dr. MURRAY BLYTH (David Lewis Northern Hospital, Liverpool) moved:

That the voluntary hospitals should provide accommodation for patients of all classes who are able to pay for it, and that no fixed rate of payment for professional services rendered to such patients should be established; the fee so payable to remain, as at present, a matter of arrangement between patient, family physician, and consultant.

Dr. P. MACDONALD, in seconding, said that the hardest hit people in the community were the middle classes, and he believed that the easiest way of dealing with them in case of illness was by establishing accommodation for them in hospital.

Dr. BLYTH, in answer to questions, said that the staff of his hospital found it impossible to particularize the phrase "of all classes." Ultimately he agreed to leave out those words.

Mr. E. H. E. STACK (Bristol Royal Infirmary) said that this motion raised the whole question of the position of the general practitioner. He himself as consultant in a hospital thought it would be very unfair if a great number of the patients of general practitioners were allowed to come in under his care in hospital when they could be looked after by the general practitioners themselves. The best solution was to institute large nursing homes.

The CHAIRMAN OF COUNCIL moved to alter the opening phrase of the motion so that it should run:

That where voluntary hospitals provide accommodation for patients who are able to pay for it, no fixed rate of payment, etc.

Dr. T. SANSOME (West Bromwich and District Hospital) seconded, remarking that this principle had been applied at his hospital for a number of years. Sir HENRY DAVY also supported the amendment, which was accepted by Dr. Blyth, and with this modification the motion was agreed to.

ATTITUDE OF MEMBERS OF MEDICAL STAFFS OF HOSPITALS AS REGARDS PAYING PATIENTS.

The final hour of the Conference was devoted to this subject.

Dr. ASTLEY CLARKE (Leicester Royal Infirmary) moved :

That in the event of decisions being taken which would lead to patients paying, in part or in whole, the hospital maintenance fees, either individually or by some contributory method, or with the addition of rate aid or State aid, or by a combination of two or more of these methods, a percentage of all such payments should be passed into a fund which can be allocated in any manner which the honorary medical staff may determine.

The mover said that it was quite obvious that the old idea of an honorary staff had passed away. All of them had received money, for example, on account of pensioners. It was most important that the so-called honorary staffs of hospitals should define their position exactly. They were out for as much philanthropy as any other portion of the community. This resolution did not propose to touch any of the money subscribed voluntarily by the philanthropic person; but when money came to an institution from the State it was but logical to claim that a certain percentage, separately determinable in each area, should be allocated to the honorary medical staff. At Leicester they had no teaching school and no paid appointments of any kind, and it was extremely difficult for a young physician or surgeon who wanted to take up hospital work to make a living at all for some years. Other hospitals presented a different state of affairs, but what he had said was certainly true of many of the big hospitals in industrial areas. Much water had flowed under the bridges since a decision was taken on this matter at the Hospital Staffs Conference at Cambridge last June.

Mr. CECIL MARRIOTT (Leicester Royal Infirmary), in seconding, said that in the case of the necessitous poor, with the hospitals on an entirely voluntary basis, the medical staffs were all willing to remain as honorary physicians and surgeons doing gratuitous work; but when it came to a question of paying patients the position was changed, and a portion of the money so received should be allocated to a staff fund. That staff fund could be distributed in various ways, but some recognition of the services of the staff should certainly be made when payment was accepted by the hospital for the patients who were in its wards. The voluntary system with regard to these patients had gone by the board.

Mr. McADAM ECCLES (St. Bartholomew's Hospital) supported the resolution. If they determined, as members of staffs of voluntary hospitals, that a sum should be paid over to a fund to be entirely administered by the medical staff of the hospital, he did not think there was anyone who could gainsay them. Of course, if such money were paid directly into the pockets of particular members of the staff, and not into a common fund, objections might at once be raised.

Dr. F. RADCLIFFE wanted to omit the reference to patients for whom payment was made by a contributory method, for those words meant that in the hospitals in industrial areas, where the workmen contributed so much a week or a year, the staffs would receive payment for practically everybody who came into the institution. ("Why not?") He would be very sorry to see their honorary status disappear so completely.

Dr. J. A. NIXON (Bristol Royal Infirmary) thought it most important that the interests of the younger men in the profession should not be neglected. Conditions had altered so greatly that they could not expect to get a really free selection of competent young men on hospital staffs unless they quite boldly changed their attitude on this matter and told the public that such men must be paid. If this money were put into a staff fund it would have the advantage that those members of the staff who had done well in practice might perfectly well forego their share, which would mean that a larger amount could be allocated to the younger men. The time had come when they should drop this comparatively modern innovation of working entirely gratuitously for hospitals.

Sir HAMILTON BALLANCE asked if the mover would agree to delete the word "honorary." In future the vast majority of patients who came into hospital would be paid for; perhaps only 10 per cent. would come in free; the rest would be pensioners of the State, or participants in a contributory scheme of payment, or individually paying patients. If as honorary officers they were only going to look after a very small minimum of patients it seemed ridiculous to retain the title. Personally he liked his honorary position with its freedom, but if they were going to be paid let them frankly relinquish the adjective.

Dr. J. H. ABRAM (Liverpool Royal Infirmary) thought that there would be plenty of time for the discussion of titles. The Royal Infirmary staff did not want any percentage on contributions from insurance companies as far as the ordinary treatment of patients under the voluntary system was concerned, but when the State took a hand in

the business they thought a certain percentage ought to come to them.

Mr. R. J. FERGUSON said that at the Kent and Canterbury Hospital it had been decided to classify patients admitted thus: (1) Those earning less than £3 a week if without dependants or £3 10s. with dependants; (2) those earning between £3 and £6 a week; (3) those earning £6 a week and over. The first class was attended free by the staff, while the others contributed certain sums. Operations were classified according to their seriousness, but for patients not needing operation it was considered that a fee of 1s. 6d. a day should be charged for the staff fund.

The CHAIRMAN OF COUNCIL hoped that the Conference would pass the resolution unanimously. Although it had been suggested that by the acceptance of a percentage payment the staff ceased to be honorary, yet no one could contest the proposition that such a sum was not a payment but an honorarium. (Hear, hear.) He hoped also that the suggestion would be taken up that there should be payments from the contributing patients in such a way that these could be put as low or as high as might seem desirable. If a hospital accepted the responsibility for the maintenance and treatment of a certain class of patients in return for payment, either at the actual time of illness or during health, the profession would be right in staking out its claim to remuneration. The remuneration at present would only be an acknowledgement, but the time might come when the whole cost for these people would be paid by the State, and if the ground had been reserved by making it quite clear that there must be an acknowledgement for service—in the case of those near the necessitous line the acknowledgement might be very little—it would safeguard the claim of the medical staff for remuneration at a later date.

Sir HAMILTON BALLANCE again pressed his suggestion that the word "honorary" should be deleted, but the CHAIRMAN did not think there need be much hesitation over the acceptance of the word. He knew of one large hospital in which the staff, always accounted honorary, had been paid an honorarium for attendance ever since 1750.

The Leicester resolution was then put and carried unanimously.

FUTURE PROCEDURE.

The CHAIRMAN said that a resolution was down in his name asking the Conference to consider the question of submitting evidence before the Government Committee and the arrangement of witnesses therefor. In view of the length of the sitting, however, he would not enter upon this subject, but he thought it very desirable that the Conference should not leave off at a loose end, and that some body should be empowered to continue the consideration of the subjects which had occupied it that day, and if necessary to call another Conference for further debate. The alternatives were that the Hospitals Committee of the British Medical Association should have that power, and perhaps be asked to co-opt certain other members for this particular purpose, or that a small *ad hoc* committee should be appointed. The latter procedure, however, would be costly and would have to be undertaken right from the beginning, whereas machinery suitable for the purpose already existed in the shape of the Hospitals Committee.

Sir RICHARD LEECE (Derbyshire Royal Infirmary) proposed, and Sir HAMILTON BALLANCE seconded, and it was unanimously agreed—

That this Conference of staffs of voluntary hospitals of England and Wales convened by the British Medical Association considers that the questions discussed by the Conference are of great importance and by no means solved as yet. The Conference therefore believes it would be well to have a mechanism whereby a similar Conference could be called as and when necessary. To this end the Conference desires to ask the British Medical Association to authorize its Hospitals Committee to call the Conference when deemed desirable.

Votes of Thanks.

Sir HENRY DAVY moved a vote of thanks to the Royal Society of Medicine for lending the hall for the Conference, and this was seconded by the CHAIRMAN OF COUNCIL of the British Medical Association, who said that his Council was greatly indebted to the Royal Society of Medicine for its hearty co-operation in the matter of that most important meeting.

The resolution was carried with acclamation, and a vote of thanks to Sir James Galloway for the excellent way in which he had presided was carried in the same manner, at the instance of Sir HAMILTON BALLANCE.

British Medical Association.

CURRENT NOTES.

The I.M.S. and the New Scale of Pay.

OWING to the number of letters received by the British Medical Association from I.M.S. officers stating that the new scale of pay announced at the Annual Representative Meeting in June last has not yet become effective, representations have been made to the India Office. A reply has been received by the Association saying that the India Office presumes that by this time the pay has been adjusted at the new rates and that confirmation of this presumption has been asked for by telegram from the Government of India. I.M.S. officers need have no doubt whatever that they will receive the new rates of pay.

Deputation from the Panel Conference to the Ministry of Health.

The members of the Executive Subcommittee of the Insurance Acts Committee met representatives of the Ministry of Health on December 17th, 1920, and discussed with them the following questions arising out of the Annual Conference of Representatives of Local Medical and Panel Committees, 1920:

Inflation of index registers. Transfer of practices. Medical records. Election of Panel Committees. Dispensing. Emergency treatment. Branch surgeries. Postage on official communications. Amendment of model form for services outside the agreement. Procedure in connexion with statutory inquiries in regard to removal of practitioners' names from list. Ministry of Health Regional Medical Officers.

After a long discussion the Ministry's representatives agreed to send to the Insurance Acts Committee a considered communication embodying the decisions arrived at. A further report will be published as soon as this is received.

"Juveniles" and Contract Rates.

The Medico-Political Committee, in its consideration of the question of the fees which should be paid in respect of attendance on families at contract rates, was in some doubt as to the exact interpretation of the term "juvenile" in its relation to contract practice rates. It appears that in some cases the term "juvenile" includes persons from infancy to the age of 16, in others the age of entrance seems to be about 5. It is clear that the risks undertaken are much greater when infants are included than when entrance is at a later age, and therefore a contract rate which would be suitable for one category of "juveniles" would not do for the other. The Medical Secretary would be glad of any information from medical men engaged in contract practice which will assist the Committee in ascertaining what is understood by the term "juvenile" in their locality.

Association Notices.

BRANCH AND DIVISION MEETINGS TO BE HELD.

BORDER COUNTIES BRANCH.—A meeting of the Border Counties Branch will be held at Carlisle on Friday, January 14th, when Major Sinclair will give his Demonstration on the Treatment of Fractures, in the Lowther Hall, Lowther Street, at 3.30 p.m. The various methods of treatment will be shown, and a lantern demonstration given. There will be a dinner of the members in the evening.

MIDLAND BRANCH: NOTTINGHAM DIVISION.—Major Sinclair, C.M.G., R.A.M.C., will give a demonstration on "Fractures" in the General Hospital, Nottingham, on Wednesday, January 19th, starting at 2 p.m. At 4.30 an adjournment will be made to 64, St. James's Street, Nottingham, for tea, at the invitation of the Nottingham Medico-Chirurgical Society. At 5 p.m. Major Sinclair will give a lantern slide demonstration, illustrating his previous demonstration. All members of the Association are cordially invited to be present at this demonstration. Major Sinclair has kindly offered to repeat this demonstration the following day for the benefit of the nursing sisters of the Nottingham and neighbouring general hospitals.

Naval and Military Appointments.

ROYAL NAVAL MEDICAL SERVICE.

The following notifications are announced by the Admiralty; Surgeon Commanders. C. J. Baxter to the *President* additional for R.N. recruiting headquarters (temporary). H. A. Kellond-Knight to the *Assistance*. H. Hunt to the *Repulse* on recommissioning. W. W. Kerr to the *Raleigh*. C. A. G. Plumps for special service with R.M. battalion. J. G. Peebles to the Osea Naval Base; Surgeon Lieutenant Commanders H. E. J. White to the *Excellent*. F. C. Alton O.B.E., to the *Valiant* (temporary). R. S. W. W. Biddulph to the *Argus* on recommissioning. Surgeon Lieutenants: E. E. Kelley to the *Argus* on recommissioning. G. L. Stanley to the *Repulse* on recommissioning.

Surgeon Lieutenant E. S. Mellor has been promoted to the rank of Surgeon Lieutenant Commander.

DIARY OF SOCIETIES AND LECTURES.

LONDON DERMATOLOGICAL SOCIETY. 49, Leicester Square, W.C.—Thurs., 6 p.m., Cheshamfield Lecture by Dr. W. Griffith: Eczema.

ROYAL SOCIETY OF MEDICINE.—*Section of Surgery*: Wed., 4.30 p.m., Exhibits; 5.30 p.m., Mr. James Berry: A further series of 500 goitre operations, with special reference to after-results. Abstracts of notes with charts and specimens will be on view at 4.30 p.m. *Section of Obstetrics*: Thurs., 8 p.m., Dr. Louise Mellroy: Morphine in Labour. Mr Percival Cole: Inoperable Uterine Carcinoma Treated by the Cold Cautery Method.

POST-GRADUATE COURSES AND LECTURES.

SALFORD ROYAL HOSPITAL.—Thurs., 4.30 p.m., Mr. Macalpine: Urinary Disease.

WEST LONDON POST-GRADUATE COLLEGE. Hammersmith, W.—Daily, 10 a.m., Ward Visits; 2 p.m., In- and Out-patient Clinics and Operations. Mon., 2 p.m., Dr. Stewart: Out-patients; 2 p.m., Dr. Simson: Diseases of Women. Tues., 2 p.m., Mr. Gray: Out-patients; 2 p.m., Mr. Davis: Throat, Nose, and Ear. Wed., 10 a.m., Mr. MacDonald: Genito-Urinary; 2 p.m., Mr. Armour: Wards. Thurs., 2 p.m., Mr. Harman: Eyes; 2 p.m., Mr. Balowio: Orthopaedics. Fri., 10 a.m., Dr. McDougal: Electrical; 2 p.m., Dr. Burnford: Out-patients. Sat., 2 p.m., Dr. Owen and Mr. Sinclair: Out-patients.

British Medical Association.

OFFICES AND LIBRARY, 409, STRAND, LONDON, W.C.9.

Reference and Lending Library.

THE READING ROOM, in which books of reference, periodicals, and standard works can be consulted, is open to members from 10 a.m. to 6.30 p.m., Saturdays 10 to 2.

LENDING LIBRARY: Members are entitled to borrow books, including current medical works; they will be forwarded, if desired, on application to the Librarian, accompanied by 1s. for each volume for postage and packing.

Departments.

SUBSCRIPTIONS AND ADVERTISEMENTS (Financial Secretary and Business Manager). Telegrams: Articulate, Westrand, London. MEDICAL SECRETARY (Telegrams: Medisecra, Westrand, London). EDITOR, *British Medical Journal* (Telegrams: Aitiology, Westrand, London). Telephone number for all Departments: Gerrard 2650 (3 lines).

SCOTTISH MEDICAL SECRETARY: 6, Rutland Square, Edinburgh. (Telegrams: Associate, Edinburgh. Tel: 4351 Central.)

IRISH MEDICAL SECRETARY: 16, South Frederick Street, Dublin. (Telegrams: Bacillus, Dublin. Tel: 4737 Dublin.)

Diary of the Association.

JANUARY.

- 11 Tues. London: Contract Practice Subcommittee, 2.30 p.m.
14 Fri. Border Counties Branch, Lowther Hall, Lowther Street, Carlisle, 3.30 p.m. Demonstration by Major Sinclair on the Treatment of Fractures.
19 Wed. Nottingham Division: General Hospital, Nottingham. Demonstrations by Major Sinclair on Fractures at 2 p.m. and 5 p.m. Tea 4.30 p.m.
21 Fri. North of England Branch: Royal Victoria Infirmary, Newcastle-on-Tyne, 2.15 to 4.30 p.m. Clinical Demonstrations.

APPOINTMENTS.

BASDEN. Miss Margaret, M.B., B.S. Lond., F.R.C.S. Eng., Honorary Obstetric Surgeon to the London (Female) Lock Hospital, with charge of the beds in the maternity and labour wards and the mental defectives' unit.

FINGAN. P. O'Connell, L.D.S., R.C.S. Eng., D.D.S., Dental Surgeon to the Male and Female Lock Hospitals.

BIRTHS, MARRIAGES, AND DEATHS.

The charge for inserting announcements of Births, Marriages, and Deaths is 9s., which sum should be forwarded with the notice not later than the first post on Tuesday morning in order to ensure insertion in the current issue.

BIRTH.

WIGHT.—At Swatow, China, on November 14th, 1920, to Dr. and Mrs. A. Wight, English Presbyterian Mission—a daughter.

MARRIAGE.

JOHNSTONE—DEMPSTER.—On December 21st, 1920, at St. Ninian's Cathedral, Perth, George Gordon Johnstone, M.C., M.D., D.P.H., to Constance Margaret, eldest daughter of Mr. and Mrs. T. Dempster of Perth.

SUPPLEMENT

TO THE

BRITISH MEDICAL JOURNAL.

LONDON: SATURDAY, JANUARY 8TH, 1921.

CONTENTS.

	PAGE		PAGE
BRITISH MEDICAL ASSOCIATION.		INSURANCE:	
PROCEEDINGS OF COUNCIL	9	The New Medical Records	12
CURRENT NOTES:		Correspondence	14
Insurance Medical Records	10	Inquiry into a Practitioner's Conduct	15
Present Position of R.A.M.C. Officers	10	Local Medical and Panel Committees	15
The Need of Early Application for Central Help	10	NAVAL AND MILITARY APPOINTMENTS	15
Distribution Committee on Central and Mileage Pools	10	Diary of Societies and Lectures	16
ASSOCIATION NOTICES:		Association Intelligence	16
Proposed Alterations of Branches and Divisions	10	Diary of the Association	16
Branch and Division Meetings to be Held	11	Appointments... ..	16
MEETINGS OF BRANCHES AND DIVISIONS	11	Births, Marriages, and Deaths	16
FEES OF DOCTORS CALLED IN BY MIDWIVES	12		

British Medical Association.

PROCEEDINGS OF COUNCIL.

A MEETING of the Council was held at 429, Strand, London, W.C., on Wednesday, December 15th, 1920, with Dr. R. A. BOLAM in the chair. There were present:

Dr. T. W. H. GARSTANG (Chairman of Representative Meetings), Dr. G. E. HASLIP (Treasurer), Dr. T. RIDLEY BAILEY (Bilston), Dr. J. A. P. BARNES (London), Sir JAMES BARR (Liverpool), Dr. J. W. BONE (Luton), Dr. H. B. BRACKENBURY (Hornsey), Dr. H. C. BRISTOWE (Wrighton), Colonel Sir W. J. BUCHANAN, I.M.S. (ret.) (Dublin), Dr. C. BULTAR (London), Mr. RUSSELL COOMBE (Exeter), Dr. J. SINGLETON DARLING (Lurgan), The Right Hon. Lord DAWSON (London), Dr. JAMES DON (Newcastle), Mr. W. McADAM ECCLES (London), Dr. A. FORBES (Sheffield), Dr. E. R. FOTHERGILL (Hove), Dr. H. A. FRANCIS (London), Dr. JOHN GOFF (Windsorham), Mr. N. BISHOP HARMAN (London), Dr. I. W. JOHNSON (Bury), Dr. R. LANGDON-DOWN (Hampton Wick), Dr. W. F. LAW (Dublin), Dr. DAVID LAWSON (Banchory), Major-General Sir RICHARD H. LUCC (Derby), Major-General Sir WILLIAM MACPHERSON, A.M.S. (ret.) (London), Dr. S. MORTON MACKENZIE (Dorking), Dr. H. C. MACTIER (Wolverhampton), Surgeon-Captain E. H. MEADE, R.N. (ret.) (London), Dr. REGINALD C. PEACOCKE (Dublin), Dr. C. M. PEARSON (Edinburgh), Dr. FRANK RADCLIFFE (Oldham), Dr. C. E. ROBERTSON (Glasgow), Dr. D. ROSS (London), Dr. D. A. SHEAHAN (Portsmouth), Dr. W. JOHNSON SMYTH (Bournemouth), Dr. W. SNODGRASS (Glasgow), Dr. F. O. STEDMAN (Weybridge), Dr. JOHN STEVENS (Edinburgh), Dr. W. B. CRAWFORD (Treasure, Cardiff), Mr. E. B. TURNER (London), Dr. E. O. TURNER (Great Missenden), Sir JENNER VERRALL (Bath).

It was reported that Sir Richard H. Luce, K.C.M.G., C.B., Dr. J. W. Bone, and Dr. James Don had been elected to fill the vacancies on the Council caused respectively by the resignations of Dr. G. K. Smiley and Dr. A. Fulton and by the election of Dr. Bolam as chairman. It was resolved to submit the name of Major-General Sir William Macpherson, K.C.M.G., C.B., A.M.S. (ret.), to the Representative Body for election to represent the Army Medical Services on the Council in the place of the late Sir William Babbie, and in the meantime to invite Sir William Macpherson to attend the meetings of the Council and the Naval and Military Committee as representing the A.M.S.

The congratulations of the Council were offered to Professor C. S. Sherrington, who has frequently taken a distinguished part in the work of the Association, on his election to the Presidency of the Royal Society. The Chairman on behalf of the Council congratulated Mr. E. B. Turner on receiving the Medal of the Order of the British Empire for exceptional services during the war.

A communication was received from Mrs. Guy Illiston stating that the Association's memorial window to her husband's memory had been put up in St. John's Church, Felixstowe, and asking the Association to accept the deep appreciation of herself and family for the gift.

Finance.

The Council resolved to increase the salaries of the two Assistant Medical Secretaries, and to increase by 33½ per cent. the retiring allowance granted in 1918 to Dr. Guy Stephen, late sub-editor. It was resolved that the Association should effect for its officials, so long as they remain in its service, policies providing for an annuity of

£300, commencing at the age of 65, and that the Association should pay the whole premiums necessary in order to secure such policies.

In view of the growing popularity and demand for the British Medical Association Lectures, an additional sum of £200 was set apart for this purpose during 1921 out of the ordinary funds of the Association.

In pursuance of a communication addressed to the Prime Minister on July 20th, 1920, on the need of State Awards for Scientific Research, the following were appointed to co-operate with the British Science Guild: Sir T. Clifford Allbutt, Professor W. E. Dixon, Dr. J. S. Haldane, Dr. R. T. Leiper, Professor Benjamin Moore, and Mr. E. B. Turner.

The Council appointed Dr. R. Scott Stevenson to the vacant post of Sub-editor of the BRITISH MEDICAL JOURNAL.

Ministry of Health.

After a long discussion on the formation of a Central Medical Committee representative of the profession as a whole, to consult with the Minister of Health on questions of policy affecting the profession, it was resolved that the preliminary negotiations for the establishment of such a Representative Committee should be entrusted to an *ad hoc* committee consisting of the officers of the Association, together with Dr. J. A. Macdonald, Sir Jenner Verrall, and Dr. H. B. Brackenbury.

In view of the present political situation, no action was taken in the matter of calling a special Representative Meeting to consider the Medical Consultative Councils' Reports to the Minister of Health.

Annual Meetings.

The Annual Meeting for 1922 will be held at Glasgow. Upon intimation by the Chairman of the Scottish Committee that Sir William Macewen had been nominated by the Branch Council as President for 1922-23, and that Sir William Macewen was willing to accept the position, the Council resolved to recommend to the Representative Body:

That Sir William Macewen, C.B., LL.D., M.D., F.R.C.S., F.R.S., D.Sc., Regius Professor of Surgery, University of Glasgow, one of the Honorary Surgeons to H.M. the King in Scotland, be elected President of the Association for 1922-23.

The report of the Arrangements Committee for the Annual Meeting at Newcastle-on-Tyne in July, 1921, was received and approved. It was resolved that the three-day Scientific Sections should be limited to five—namely, Medicine, Surgery, Pathology and Bacteriology, Orthopaedics and Children's Diseases, Preventive Medicine and Industrial Diseases; that the two-day Sections be limited to six—namely, Oto-Rhino-Laryngology, Ophthalmology, Neurology and Psychiatry, Venereal Diseases, Obstetrics and Gynaecology, and Physiology Pharmacology Therapeutics and Dietetics; and that the following single-day Sections be held: Ambulance and Red Cross, Dermatology, Radiology and Electro-Therapeutics, Urology, Proctology,

and Medical Sociology. In connexion with the Newcastle Annual Meeting, Sir Thomas Oliver, M.D., will be invited to deliver a Special Address in Industrial Medicine on the evening of Wednesday, July 20th, and Professor Arthur Keith, F.R.S., to deliver a Popular Lecture on the evening of Friday, July 22nd. The President-elect, Professor David Drummond, C.B.E., M.D., D.C.L., will deliver his Presidential Address on Tuesday, July 19th, at 8.30 p.m. The Sections will meet as usual on the Wednesday, Thursday, and Friday. The Annual Representative Meeting will begin on the Friday of the preceding week—July 15th—at 10 a.m.

Professional Civil Servants in Ireland.

The Institution of Professional Civil Servants (Ireland) lately invited the Association to join in a deputation to the Government with respect to the Government of Ireland Bill. The object of the deputation is to press upon the Government various reasons for the amendment of the bill with a view to safeguarding, in any change that may come about as a result of the passing of the bill, the interests of present permanent established and unestablished professional and technical civil servants in Ireland. It was reported to the Council that the officers of the Association had nominated the Chairman of Representative Meetings to take part in the deputation.

Medico-Sociological Committee.

The Council, at its previous meeting on October 6th, 1920, resolved that a Medico-Sociological Committee be appointed experimentally, to consider social and economic questions affecting the public welfare as to which the medical profession has special knowledge, and to take such steps as may be found necessary in order to create or develop public opinion thereon. Having heard a report on this matter the Council on December 15th decided that the Medico-Sociological Committee should consist of the officers of the Association (*ex officio*), the Chairmen of the Medico-Political, Hospitals, Insurance Acts, and Public Health Committees, Drs. E. R. Fothergill, A. Forbes, A. C. Farquharson, M.P., and S. Morton Mackenzie, with power to add additional members, medical or lay, not exceeding six in all, for the consideration of the subject which the Association members of the Committee propose for the time being to consider.

CURRENT NOTES.

Insurance Medical Records.

In view of the controversy in the public press with regard to the new medical records which came into force on January 1st it may be advantageous to recapitulate the action which has been taken in this matter by the Insurance Acts Committee and by the Conference of Local Medical and Panel Committees.

The Insurance Acts Committee accepted the obligation to keep records in some form, and agreed that the prime purpose of the records should be clinical and not statistical or administrative, but it was not prepared to express any opinion as to the propriety of the present proposals until some experience had been gained of their working. Accordingly, the Insurance Acts Committee recommended to the Conference of Local Medical and Panel Committees that the new form of record must be tried before it could be either condemned or approved. This recommendation met with the approval of the annual Conference of Local Medical and Panel Committees held in October last, and an amendment urging non-acceptance of these records by practitioners was lost. In preparing the case for arbitration in connexion with the revised capitation rate it was recognized that some new system of medical records would be instituted, and insurance practitioners throughout the country were aware that it would be incumbent upon them to keep some form of record in the near future. When the question of medical records was discussed at the October conference no mention was made of the possible violation of professional secrecy as a result of keeping these records; in fact no objection at all was raised on ethical grounds, and if proper care is exercised by practitioners, and those persons who are appointed to scrutinize the records for statistical purposes have a proper sense of responsibility, there need be no violation of any secrets which insurance practitioners, in common with other practitioners throughout the country, are anxious to safeguard.

Present Position of R.A.M.C. Officers.

The Naval and Military Committee of the British Medical Association at its last meeting considered a letter drawing attention to several matters which are causing dissatisfaction among the officers of the Royal Army Medical Corps. Owing to the death of Sir William Babbie, who had proved himself invaluable from his wide experience and knowledge of army affairs, there was at that time no one on the Committee who directly represented the Army Medical Service. Since the Committee last met the Council of the Association has been fortunate in securing the help of Major General Sir William G. Macpherson, K.C.M.G., C.B., A.M.S. (ret.), as representative of the Army Medical Service, and in that capacity he will be a member *ex officio* of the Naval and Military Committee. In the meanwhile officers of the R.A.M.C. who are members of the Association may rest assured that a close watch on their interests is being maintained.

The Need of Early Application for Central Help.

It sometimes happens that medical practitioners fail to achieve success in local fights because they have not applied soon enough for assistance from the head office. The following is a case in point: An Education Committee decided to appoint an additional whole-time officer to do work which had previously been done by the local practitioners, and which they were ready and willing to continue to do. The local profession put up a very good fight in the committee for the continuation of the employment of general practitioners, and very nearly succeeded in carrying their point. The British Medical Association heard nothing of the case until it was too late to take effective action. Had central aid been applied for at an earlier date there might well have been a different result, for there is plenty of experience to show that a combination of local and central pressure often succeeds where either alone would have failed. It should be borne in mind that the Association through its central and local machinery can do a very great deal to help the profession in cases of this kind, but assistance must be applied for early.

Distribution Committee on Central and Mileage Pools.

For the information of rural insurance practitioners in particular, we publish the following complete list of the medical members of the Ministry of Health Distribution Committee on Central and Mileage Pools: Dr. H. G. Dain (Birmingham), Dr. H. J. Farman (London), Dr. E. Lewys-Lloyd (Merioneth), and Dr. J. P. Williams-Freeman (Andover); with the addition of Dr. T. Wood Locket (Melksham, Wilts) and Dr. Wm. Baigent (Northallerton, Yorks), when questions concerning the Central Mileage Fund are under consideration. All the above practitioners were nominated by the Insurance Acts Committee.

Association Notices.

A LEWISHAM DIVISION.

NOTICE is hereby given by the Council to all concerned that, as a result of a proposal made by the members of the Association resident in Lewisham, the Council has decided that as from January 8th, 1921, a Lewisham Division be formed of area co-terminous with the Borough of Lewisham, the new Division to form part of the Metropolitan Counties Branch, and the existing Woolwich and Lewisham Division to be modified accordingly.

PROPOSED ALTERATION OF AREA OF MIDLAND BRANCH, AND FORMATION OF A LINCOLNSHIRE BRANCH.

NOTICE is hereby given under Article 12 and By-law 77 to all concerned of a proposal made by the Midland Branch Council for subdivision of that Branch into two Branches, as follows:

Midland Branch: Area to be co-terminous with the combined areas of the existing Chesterfield, Derby, Leicester and Rutland, and Nottingham Divisions.

Lincolnshire Branch: Area to be co-terminous with the combined areas of Holland, Kesteven and Lincoln Divisions.

Written notice of the proposal has been given to all concerned, and the matter will be determined in due course.

by the Council. Any member affected by the proposed change, and objecting thereto, is requested to write, giving reason therefor, to the Medical Secretary, 429, Strand, W.C.2, not later than February 8th, 1921.

PROPOSED FORMATION OF A SHANGHAI BRANCH.

NOTICE is hereby given to all concerned of a proposal made by the members and non-members of the Association resident in Shanghai, for formation of a Shanghai Branch of the Association, of area such as may be agreed upon with the Hong Kong and China Branch. The matter will be determined in due course by the Council. Any member affected by the proposed change, and objecting thereto, is requested to write, giving reason therefor, to the Medical Secretary, 429, Strand, W.C.2, not later than April 30th, 1921.

LIBRARY OF THE BRITISH MEDICAL ASSOCIATION.

A LIST of periodical publications, official reports, and Blue Books in the Library of the British Medical Association available for issue to members on loan has been printed, and copies can be obtained free on application to the Librarian at the house of the Association, 429, Strand, W.C. The regulations governing the loan of these publications are stated in the introduction to the list. The Library is open for consultation from 10 a.m. till 6.30 p.m. (on Saturdays 10 a.m. till 2 p.m.).

BRANCH AND DIVISION MEETINGS TO BE HELD.

BORDER COUNTIES BRANCH.—A meeting of the Border Counties Branch will be held at Carlisle on Friday, January 14th, when Major Sinclair will give his Demonstration on the Treatment of Fractures, in the Lowther Hall, Lowther Street, at 3.30 p.m. The various methods of treatment will be shown, and a lantern demonstration given. There will be a dinner of the members in the evening.

MIDLAND BRANCH: NOTTINGHAM DIVISION.—Major Sinclair, C.M.G., R.A.M.C., will give a demonstration on "Fractures" in the General Hospital, Nottingham, on Wednesday, January 19th, starting at 2 p.m. At 4.30 an adjournment will be made to 64, St. James's Street, Nottingham, for tea, at the invitation of the Nottingham Medico-Chirurgical Society. At 5 p.m. Major Sinclair will give a lantern slide demonstration, illustrating his previous demonstration. All members of the Association are cordially invited to be present at this demonstration. Major Sinclair has kindly offered to repeat this demonstration the following day for the benefit of the nursing sisters of the Nottingham and neighbouring general hospitals.

Meetings of Branches and Divisions.

ESSEX BRANCH: NORTH-EAST ESSEX DIVISION.

A CLINICAL meeting of the North East Essex Division was held at the Essex County Hospital on December 11th, 1920. Dr. S. W. CURT was in the chair. Dr. MILNER BURGESS (Frinton-on-Sea) read a paper on a case of glioma or gamma of the brain. Dr. HIRKINOTHAM (Colchester) showed a case of aortic incompetence with a curious murmur audible in the mouth. This case caused much discussion. Dr. FELL showed a case of myxoedema and a case of disseminated sclerosis simulating cerebellar tumour.

On December 17th a dinner was held in the Red Lion Hotel, Colchester. Dr. S. W. CURT was in the chair. Dr. ALFRED COX, the guest of the evening, spoke on the probable developments of medical service in this country and how the British Medical Association may mould them. Dr. Cox anticipated more State interference with general practice and the extension of the Insurance Act to dependants. He explained the course of negotiations between the Government and the British Medical Association with regard to various health measures in the past and showed how the Association had gained many points for the profession; the relative position of bargainers was one of give and take, and always must be so. Had the profession understood this during the negotiations over the Insurance Act it would have won a notable victory for the Association. In the future the Association could, by holding together and negotiating wisely, mould the various legislative measures proposed into practical and beneficial measures for all concerned. Increased membership was required, since the Ministry of Health was unwilling to negotiate with numerous bodies each claiming to represent the profession. At the close of his speech Dr. Cox answered many questions.

METROPOLITAN COUNTIES BRANCH: MARLBORNE DIVISION.

A MEETING of the Marlbone Division was held at 11, Chandos Street, on December 14th, 1920, when Sir JAMES GALLOWAY was in the chair. The following were elected representatives of the Branch Council: Sir James Galloway, Dr. B. Hartzkorne, Dr.

Halliday Sutherland, Mr. H. S. Souttar, Dr. Gouillet, and Dr. Blackhall-Morison.

A discussion on the question of "Multiple door-plates" was opened by Dr. ESTELLE COLL. She stated that in the neighbourhood there were houses sublet to doctors who were debarred from putting up plates; also that there were some houses in which doctors were not allowed to practise at all. Several members took part in the discussion. Much light was thrown on the matter by Mr. BISHOP HARMAN, who dealt with the legal position of the tenants and ground landlords. It was eventually decided that the Division was not in a position to take any action, and a resolution to this effect was carried.

The meeting passed a resolution sympathizing with Mr. Edward Wallis, the honorary secretary, in his severe illness, and expressing hope of his speedy recovery.

METROPOLITAN COUNTIES BRANCH: WILLESDEN DIVISION.

A MEETING of the Willesden Division (to which non-members were invited) was held on December 22nd, 1920, at St. Andrew's Parish Hall, Willesden, with Dr. CRONE in the chair.

Rates for Contract Work.—The following resolution, of which due notice had been given, was agreed to without dissent, and the honorary Secretary was instructed to circulate a copy to every member and non-member in the Division:

That rates for contract work in Willesden be not less than the insurance rates—that is, 3d. per week per person over 15 years, and for those under 15 years 2d. per week.

Local Health Council.—The CHAIRMAN reported that the Division's three representatives (Drs. Paterson, Scott, and himself) on the Willesden Local Health Council had attended a preliminary meeting with representatives of the Urban District Council, the board of guardians, and the Cottage Hospital. Dr. Buehan, M.O.H., had briefly summarized the Medical Consultative Council's Report. The Chairman stated that the general impression he gathered as to the views of those present was that while approving the proposals of the Report they were of opinion that the time was not ripe for the inauguration of the scheme, and that the question of finance would militate against its early inception. He added that at the meeting he had pledged his word that if the scheme was inaugurated the Willesden profession would work it, and that eventually the Committee had appointed a small subcommittee (to which their honorary secretary, Dr. Paterson, was appointed) to draw up an agenda embodying the outlines of the Consultative Council's Report and indicating how far it could be carried into effect.

The Medical Officer of Health's Report. A discussion of the forty-fourth annual report of the medical officer of health for Willesden was opened by Drs. McEVoy and SKENE, who both regretted the absence of the medical officer of health, Dr. BUCHAN. They drew attention to the great increase in the medical activities of the Urban Council, chiefly carried out through the Health Committee; to the apparent ignorance of such activities on the part of the great body of over 100 medical practitioners in the locality; and to the necessity for the medical profession of the area to stir itself and take a hand in the formulation, guidance, and carrying out of those activities. They felt that the District Council should be asked to co-opt two or three of the local profession to its Health Committee, and that the profession itself should have its own small committee to consider these matters and advise both the local profession and the District Council. Reference was made to what appeared to be fallacious deductions from certain medical statistics, the speakers criticizing the undue magnification of inferences favourable to officials, and the slurring over of inferences creditable to the local profession; and to the fact that the general practitioners of the area were not utilized for the medical examination and treatment of school children at present carried out by the whole-time medical officers. Discussing the work and conduct of the baby clinics and isolation hospital, it was remarked that the latter had apparently during the war without any reference to members of the local profession and while a considerable number were serving with His Majesty's forces blossomed out into a municipal hospital staffed by whole-time medical officers. Dr. Skene added that as a reconvert to the British Medical Association he could not help pointing out that this report emphasized the great necessity for organization by the members of the medical profession, and that the Association, despite its faults and past mistakes, was the only medical organization capable of assisting them in organizing and fighting for the "family doctor."

Drs. STOCKER, SCOTT, LOCK, and others took part in the discussion, and the meeting agreed that efforts should be made to secure the election of two medical members to the District Council. The members present expressed their appreciation of the exceedingly able and thorough examination of the M.O.H.'s report placed before them by Drs. McEvoy and Skene.

Consideration of the question of a practitioner's mutual help scheme, which was to have been introduced by Dr. C. T. F. Scott, was postponed to the next meeting in view of the lateness of the hour.

On Tuesday, January 18th, Dr. Christine Murrell will open a discussion on "Maternity and child welfare clinics."

SOUTHERN BRANCH.

A MEETING of the Southern Branch was held at Portsmouth on December 9th, 1920, when Dr. A. A. MACKLITH (Southampton) was in the chair.

Dr. A. BOSWORTH WRIGHT, nominated by the Portsmouth

Division, was unanimously appointed as President elect. Seven new members were elected, bringing the membership up to 327.

Dr. D. SHEAHAN gave a full account of his stewardship as Representative at the Annual Representative Meeting for the past eleven years, during which time he had never missed a Division meeting.

The President (Dr. MACKETH) then invited a discussion on the Report of the Consultative Council. The matter having been very fully considered by the Divisions, the feeling of the meeting was that no useful purpose would be served by going over the ground again. The President then moved the following resolution:

While strongly supporting most of the provisions of the scheme outlined in the Report of the Consultative Council as an ideal to be kept in view, this meeting of the Southern Branch of the British Medical Association desires to point out that the matters calling for immediate attention are: (1) The greater provision of consultants and specialists. (2) The provision of the services of midwives and nurses. (3) The provision of the services of bacteriologists and pathologists. (4) The supply of vaccines and similar preparations. (5) The extension of medical attendance to the dependants of insured persons.

Mr. C. P. CHILDE moved the following amendment, which was seconded by Mr. LOCKHART STEPHENS:

In the opinion of the Southern Branch, the revolution in the practice of medicine outlined in the Report of the Consultative Council, whatever its advantages, is wholly inopportune in view of the obvious financial burden it will place on the shoulders of the taxpayer. The consideration therefore of any change of this sweeping character should be deferred until such time as the country has recovered from the crushing financial straits to which it has been reduced owing to the late war.

Dr. MEARNS FRASER and Mr. SCOTT RIDOUT spoke in favour of the amendment, and Dr. ALDERSON opposed it. On the vote being taken the amendment was carried with two dissentients.

SOUTH-WESTERN BRANCH: EAST CORNWALL DIVISION.

A MEETING of the East Cornwall Division was held at Liskeard on December 8th, 1920, when Dr. H. C. JONAS, President of the Branch, Mr. RUSSELL COOMBE, Chairman of the Organization Committee, and Dr. F. A. ROPER, Honorary Secretary of the Branch, were present. The following officers were elected:

Chairman: Dr. W. Nettle. *Vice-Chairman:* Dr. H. A. Burrowes. *Representative in Representative Body:* Dr. J. G. Morgan. *Honorary Secretary:* Dr. E. H. Hugo (Bodmin).

Dr. HUGO pointed out the impossibility, owing to the long distances, bad roads, and inconvenient and round-about railway service, of ever getting together a large meeting of the Division, and suggested that it might possibly be advisable to divide up the area into two Divisions.

Dr. JONAS expressed his pleasure at the revival of this Division after so long a period of inactivity, and Mr. RUSSELL COOMBE, in endorsing the President's remarks and congratulating the Division, gave a full and interesting summary of the work of the Association from its inception to the present day, for which account the meeting accorded him their thanks.

The meeting considered the interim report of the Consultative Council of Medical and Allied Subjects and recorded answers to the questions.

ULSTER BRANCH: BELFAST DIVISION.

THE opening meeting of the Belfast Division was held in the Medical Institute on December 9th, 1920. The following officers for 1920-21 were elected:

Chairman: Dr. R. Reid. *Treasurer and Secretary:* Dr. W. L. Storey. *Representatives in Representative Body:* Drs. R. W. Leslie and A. G. Robb.

The following resolution was adopted:

That this meeting take this the first opportunity of expressing its opinion that it is unjust of the authorities to ask medical practitioners to examine candidates for, or members of, the Special Constabulary without remuneration, and that those practitioners who have already made examinations *gratis* should be paid for their professional services.

The Honorary Secretary was instructed to send copies of the resolution to the local press and to the signatories of the notice that appeared in the newspapers regarding the enrolment of special constables.

FEES OF DOCTORS CALLED IN BY MIDWIVES.

THE Ministry of Health has issued to local supervising authorities under the Midwives Act a new scale of fees to be paid by the authorities to medical practitioners called in by midwives under Section 14 of the Midwives Act, 1918; this scale will take the place of that prescribed in December, 1918, by the Local Government Board, and comes into operation as from January 1st, 1921.

The chief alterations made by the new scale are: (1) The fee for attendance at confinements is 2 guineas in all cases, instead of 1 guinea in ordinary cases and 2 guineas in those necessitating operative issues; (2) a special fee of 1 guinea is prescribed for operative assistance given after the confinement, and also for attendance at abortions or miscarriages; (3) the fee for visits is increased to 5s. by day, and 10s. by night.

In a circular letter accompanying the new scale of fees local supervising authorities are asked to notify the terms of the new scale to the doctors practising in their districts; they are also reminded that they are empowered to recover the fee except in cases of poverty. The prescribed scale of fees is framed in the following terms:

	£	s.	d.
1. Fee for all attendances of a doctor at parturition—that is, from the commencement of labour until the child is born—whether operative assistance or not is involved, including all subsequent visits during the first ten days, inclusive of the day of birth	2	2	0
2. Fee for attendance of a second doctor to give an anaesthetic, whether on account of abortion or miscarriage, at parturition or subsequently	1	1	0
3. Fee for suturing the perineum, for the removal of adherent or retained placenta, for exploration of the uterus, for the treatment of post-partum haemorrhage, or for any operative emergency arising directly from parturition, including all subsequent necessary visits during the first ten days, inclusive of the day of birth	1	1	0
4. Fee for attendance at, or in connexion with, an abortion or miscarriage, including all subsequent visits during the ten days after and including the first visit	1	1	0
5. Fee for visits to mother or child not included under (1) to (4): Day (9 a.m. to 8 p.m.)	0	5	0
Night (8 p.m. to 9 a.m.)	0	10	0
6. The usual mileage fee of the district to be paid for all attendances under (1) to (5) of this scale.			
7. No fee shall be payable by the local supervising authority (a) where the doctor has agreed to attend the patient under arrangement made by or on behalf of the patient or by any club, medical institute, or other association of which the patient or her husband is a member; (b) where the doctor receives or agrees to receive a fee from the patient or her representative; (c) in respect of any services performed by the doctor after the expiry of four weeks from the day of birth.			

INSURANCE.

THE NEW MEDICAL RECORDS.

THE Interdepartmental Committee appointed by the Minister of Health to consider the form of medical record to be kept by insurance practitioners issued its report¹ last summer; a summary of this report was given in the SUPPLEMENT of July 31st, 1920, at p. 53. The obligation on insurance practitioners to keep records, which was in abeyance during the war period, is defined in the terms of service under the Medical Benefit Regulations; a practitioner is required "to keep records of the diseases of his patients and of his treatment of them in such form as the Minister may from time to time determine." The Committee recommended that such notes should be kept of every case treated as are likely to be of value to the practitioner himself, or to any other practitioner treating the same patient in subsequent illnesses. The form of record which would best meet this purpose, and would serve both as a medical record and as an index card, was described in the report and further illustrated in appendices. The Minister of Health accepted the Committee's recommendations relating to England and Wales, and the coming into force of the arrangements was fixed for January 1st, 1921.

Professional Secrecy under the System.

The new insurance records have been criticized in the public press on two grounds. The first objection is that insurance practitioners under paragraph 8 (13) (c) of the Terms of Service are required to afford to medical officers of the department, or such other persons as they may appoint for the purpose, access at all reasonable times to these records, and to furnish them with the records, or with any necessary information with regard to entries therein which they may require. There does not appear to be much substance in this criticism. The country has acquiesced in the insurance scheme, and it would probably often be impossible for medical officers of the Ministry of Health to utilize the records in the manner desired without employing confidential subordinates. The Ministry's concern with the information to be obtained from the cards will be mainly statistical.

The second criticism is to the effect that when an insurance patient changes his doctor the record card may pass into the hands of clerks employed in the offices of the Insurance Committees. With regard to this objection, it may be well to quote from paragraph 49 of the Committee's report:

"When the patient changes his insurance practitioner it will be necessary, in order to preserve the continuity of the record, to ensure that it is transferred from the old to the new doctor.

¹ Cmd. 835. H.M. Stationery Office. Price 3d. net.

The machinery of Insurance Committees will necessarily be utilized for this transmission, and provision could be made for avoiding disclosure of particulars of the illnesses from which patients have suffered to those engaged in the handling of the records in their transference by the use of special 'window' envelopes (in the form set out in Appendix IV). While thus avoiding disclosure that might be (or might at least be feared to be) prejudicial to the interests of insured persons, the use of these 'window' envelopes would enable the committees to make such entries on the front of the records as are rendered necessary in consequence of change of a doctor. The doctor previously responsible for the treatment of a patient who had been accepted by another doctor, on receiving intimation that the patient was removed from his list, would forward the record in one of these 'window' envelopes, enclosed in an outer envelope, to the Insurance Committee, who would arrange for its transfer to the new doctor if he resides in that area, or to another Insurance Committee if the new doctor resides in another area."

The "window" envelope is the method devised for "avoiding disclosure." These envelopes have an adhesive flap, and it appears to be intended, though it is nowhere so stated, that the old doctor, before sending the record on to his Insurance Committee, should close the flap. The "window" envelope ought to reach the new doctor closed and intact, for this is the means taken to preserve professional secrecy in the transmission of the card from the old doctor to the new. Short of improper action by the clerical staff of one or other of the Insurance Committees when two are concerned, the method would appear to ensure secrecy.

Instructions to Practitioners.

The Interdepartmental Committee advised that at the time when the new records were brought into operation practitioners should be furnished with a memorandum explanatory of the objects they are intended to serve and the mode in which they should be kept, and that a printed card giving concise directions as to the method of filling up and transmitting the records should be supplied for filing with the record cards. This suggestion has been carried into effect by the Ministry of Health, which has issued a Memorandum (274 I.C.) for the guidance of insurance practitioners, together with a card (274A I.C.) summarizing the instructions. The introduction states that the new form of record is based upon the recommendations of the Interdepartmental Committee. The objects the record is intended to fulfil are classified into (a) clinical, (b) administrative, and (c) statistical.

Clinical Purpose.

The clinical purpose, which is regarded as of paramount importance, is "to contribute to the efficient treatment of insured persons by preserving in a permanent and readily accessible form records of such clinical data as are likely to be of assistance to the practitioner making the record, or other practitioners under whose care the patient may subsequently come." To attain this object the record has been made continuous. It will be kept ordinarily in the possession of the practitioner who has, for the time being, the insured person under his care, "so that a connected history of illnesses may be obtained, and opportunity afforded for tracing the connexions and interactions of one illness with another." While it will be left, broadly, to the practitioner's judgement "to decide what notes are likely to be of value in a particular case, this discretion must clearly be exercised reasonably" and with due regard to the colleagues who will be dependent on him for useful notes concerning patients who, through removal or otherwise, may pass from his care to theirs. On the subject of trivial ailments a quotation is given from the Committee's report:

"The ultimate value, in a continuous history, of a note of disturbances to health, which at the moment may appear relatively unimportant, cannot be determined with confidence at that time, inasmuch as they may only manifest their true significance when they can be considered in their relation to subsequent occurrences."

The clinical part of the record is arranged in two columns headed respectively "Clinical Notes" and "Diagnosis." The second column is intended for definite diagnoses only, of which the practitioner feels reasonably certain. In order to economize time the use of certain symbols is permitted in making Clinical Notes in the first column. These symbols are:

"S.M. = minor surgery; Tr. = minor surgery (cases of injury); D. = digestive disturbance (undefined); Rh. = rheumatism and allied conditions; R.C. = catarrh of the respiratory tract; P.C.O. = pyrexia of unknown origin."

No other symbols are countenanced, nor any abbreviations that might not be readily intelligible to every medical man.

Administrative Purpose.

The most important data required under this head are a record of occasions (a) on which a patient is seen by the doctor, and (b) on which certificates of incapacity are given. Every visit or surgery attendance must be entered, but a special

arrangement has been made for reducing the labour of entry in cases in which another record (daybook or visiting list) is kept. This allows the practitioner, after entering the first three attendances or the first visit on the card, to insert weekly the total number of attendances, and weekly or monthly the total number of visits, giving the date of the first and last of these attendances or visits. As regards certificates, an entry is required on every occasion on which a first and on which a final certificate is given.

Method of Keeping Records.

The new form of record is thus described in the memorandum for the guidance of insurance practitioners:

"It takes the form of an envelope, which is itself the first record, and in which continuation cards will subsequently be placed. Each insurance practitioner will shortly receive from the Insurance Committee an envelope record in respect of each insured person on his list. These records will also take the place of the present Medical Index Cards. In order to relieve the doctor of clerical work the first portion of each envelope record will be completed, before issue, to show the insured person's name, address, society, an I number, the practitioner's name, the committee's cipher, and the date of issue. The records relating to men will be ruled in red, and those relating to women in blue. In addition to verifying the particulars already appearing on the envelope record the practitioner should, on the occasion of the insured person's first attendance for treatment, insert particulars as to occupation and age. Any subsequent alteration or addition should be made, when ascertained, in the appropriate space."

When the space on the back of an envelope is filled, further details are to be entered on a continuation card, which should be kept in the envelope record. On the death of an insured person the record is to be completed and forwarded to the Insurance Committee. When an insured person, by reason of removal or otherwise, transfers to the list of another practitioner, either in the same or another area, or goes out of insurance, the practitioner holding the record must forward it to the Insurance Committee when requested. When treatment is given to an insured person in respect of whom no envelope is held, a continuation card should be used by the practitioner pending arrival of the envelope. In the case of temporary residents and "travellers" a continuation card should be kept and forwarded to the Insurance Committee on the completion of treatment.

The memorandum refers as follows to the transmission of records through the post:

"These medical records are confidential documents. The Insurance Committees will supply practitioners with two kinds of envelopes: (1) A 'window' envelope, which is designed to conceal effectively the medical particulars inserted on the cards; and (2) a larger envelope, in which the 'window' envelopes and their contents can be transmitted through the post to the Insurance Committee. The covers sent through the post must bear postage stamps in the ordinary way, and practitioners will be informed by Insurance Committees of the arrangements for making payment to them of an allowance in respect of the additional expenditure incurred in connexion with the postage of these records."

STATEMENT BY THE MINISTRY.

The following statement by the Ministry of Health has been circulated to the press:

In view of the unfounded apprehension that may be created in the minds of insured persons and others by certain press criticisms of the new system of medical records to be kept by insurance practitioners, the Minister of Health thinks it desirable to issue a short statement on this subject.

In the original framing of the Regulations under the Insurance Act the importance was recognized of systematic recording of illnesses, both for the assistance of the doctor in treatment and for the collection of facts which would contribute to medical progress. At that time, however, it was thought desirable, in order to avoid any possible objections on the ground of professional secrecy, that particulars of illnesses should be entered by the doctor on one half of a folded card, and particulars identifying the patient on the other half, that these should be separated at the end of each year, and that thus when the two halves had been forwarded separately, one to the Insurance Committee for administrative purposes, containing no particulars of illnesses, and the other, containing the records of illnesses, to the Central Department, there would be no means of identifying the person who had suffered from these illnesses.

This feature of the system was much criticized by the medical profession on two grounds: first, that the doctor did not have in his possession a continuous record from year to year, and thereby obtain the assistance in the treatment of his patient that such a record would have afforded; second, that the history of illnesses in successive years could not be traced for statistical purposes, thus destroying much of the value the cards might otherwise have had in this way.

The Departmental Committee, presided over by Sir Humphry Rolleston, devoted, as their report shows, much thought to the

question of how a continuous record could be obtained without prejudicial disclosure of the patient's illnesses. This they considered they had attained by the system they proposed of "window envelopes," in which the cards could be transmitted from one doctor to another when a patient moved from one area to another. These envelopes are so devised that when sealed by the doctor no medical particulars are accessible to the officials of Insurance Committees through whose hands the envelopes pass; thus the procedure provides for medical particulars being conveyed from doctor to doctor without possibility of disclosure of medical particulars to any person in transit, unless he should, quite improperly, break the seal of the envelope. It is not to be believed that responsible officials will be so carried away by impertinent curiosity as to be guilty of an impropriety, particularly as the confidential nature of the records has been emphasized in the instructions to Insurance Committees.

The other possibility of leakage which is alleged is through the system of inspection of the records by medical officers of the Ministry, or "such other persons as they may appoint for the purpose." These words are inserted so that when required certain trustworthy clerks, who are established civil servants, may be employed to see that the more formal parts of the record are being properly kept, a purpose for which it is not necessary that the time of the medical officers themselves should be taken up. But the medical officers will themselves see the records from time to time for the purpose of assisting insurance practitioners in keeping the more distinctively medical part of the record and in connexion with consulting or referee duties.

For such inspection by persons other than medical officers there are a number of parallels. For example, full particulars of the cases of patients treated are kept in the registry of every important hospital, and are accessible for preservation and filing purposes to the clerical staff of the institution, but no one has thought it yet to say that hospitals must be prevented from keeping records of patients treated or preclude any but the medical staff from the handling of the records which is necessary in order that their full value may be obtained.

The Departmental Committee, composed mainly of medical men, devoted in their report a paragraph to the subject of the growing necessity, if the advance of medicine is to be properly maintained, of clerical work in connexion with medical practice, and pointed out that if the doctor is not to be diverted from his more strictly medical functions by work of this kind it is necessary that medically unskilled assistance should be employed for the purpose.

Summing the matter up, the system impugned has been carefully devised by an expert and mainly medical committee with the express object of meeting the desire of the profession for records that will be of real value in the treatment of disease and in the advancement of medical knowledge, and at the same time of preserving, in a way that the patients themselves are likely to desire, that secrecy as to medical particulars on which the medical profession itself has rightly always laid such stress.

CORRESPONDENCE.

Mutual Aid Schemes.

SIR,—In the SUPPLEMENT of the BRITISH MEDICAL JOURNAL for December 11th, page 153, Mr. Bishop Harman, speaking on what the work of a Division should be, said: "Secretaries might well study the Sheffield scheme for co-operative work during holidays or sickness of members." It may be of interest to the profession to know that in Leicester we have had in operation for two years a scheme of collective locum tenencies during holidays or sickness, which has been a conspicuous success.

The scheme is based on practitioners being invited to express their willingness to do some of the work of members absent on holiday or through illness, and on those members of the profession who desire to avail themselves of the facilities afforded by the scheme, contributing at certain rates to a pool. After payment of the necessary expenses for printing, etc., the sum remaining is divided amongst the members doing the work of absent doctors at so much per unit on the number of patients attended.

During the summer of 1919, £163 16s. was contributed to the pool. The expenses amounted to £5 16s. 3d., leaving £156 19s. 9d. to be distributed. During the summer of the current year £275 5s. was paid into the pool. The expenses amounted to £4 2s. 8d., and £271 2s. 4d. was distributed amongst those who did the work.

At the present time a scheme is in operation for sickness and short holidays during the winter months, and this has already proved very useful in a number of cases. —I am, etc.,

E. LEWIS LILLEY,

Honorary Secretary Leicester Panel Committee, and
Chairman Leicester Public Medical Service.

Leicester, Dec. 20th, 1920.

SIR,—The SUPPLEMENT of December 11th, 1920, contains a reference to the Sheffield scheme for mutual aid in holidays and in emergencies. The Sheffield Division do not

claim entire credit for the idea, as their scheme is built very largely on one which has been in force for some time in Middlesbrough. It is felt that this disclaimer is due to the Cleveland Division, who so readily gave valuable assistance while the scheme was being organized in Sheffield.—I am, etc.,

Sheffield, Jan. 3rd.

W. H. HELM.

The London Panel Committee.

SIR,—Dr. Brackenbry's very temperate and conciliatory letter in the SUPPLEMENT to the BRITISH MEDICAL JOURNAL of December 18th, 1920, under the above heading, makes clear the reason for the policy of the London Panel Committee which he criticizes. He says "the Committee's"—that is, the Insurance Acts Committee of the British Medical Association—"chief duty is to watch over the interests of the whole profession in its relation to the National Insurance Acts and their developments." With this statement we agree, but the fact that this is the Committee's chief duty naturally makes many doubtful as to its ideal fitness to have also as its chief duty the watching over of the interests of that part of the profession which has undertaken work in connexion with the Insurance Acts. It may be that those interests are identical, but they may not be, and in order to protect the interests of practitioners engaged in insurance work, the policy of the London Panel Committee is to establish in some form or other an independent executive committee of the Conference of Local Medical and Panel Committees. The object of such an executive would be to learn what are the views of the Conference as to the interests of their constituents, to support those views against all comers if so instructed, or to make, if so permitted, compromises on those views in the interests of the profession as a whole, but in all things to act as an instrument of the Conference and of the Conference alone.

As a constituent member of the Association of Panel Committees, the London Panel Committee believe that the aim they have in view would be secured by the development of that association.

Dr. Brackenbry's statement that the London Panel Committee are inconsistent in withdrawing their support from the Defence Fund will not bear examination. The London Panel Committee's contention is that this Fund, which is now almost entirely provided by Panel Committees, should be entirely so provided, and whilst bearing the cost of the Conference and other activities in connexion with safeguarding the interests of the Panel Committees' constituents, should not be used for any other purpose. In the London Panel Committee's opinion this position can only be satisfactorily secured by entrusting the Fund to a body directly elected by, and solely responsible to, the Conference of Panel Committees. Holding these views the Panel Committee for London could not consistently support the Defence Fund so long as it is entrusted to a body not so constituted.—We are, etc.,

H. J. CARDALE, E. A. GREGG,
W. COODE ADAMS, R. DUNSTAN,
LAURISTON E. SHAW, R. J. FARMAN.

Staple House, Chancery Lane, W.C.2.
Dec. 21st, 1920.

SIR,—At a recent meeting of this Committee, Circular Letter No. 191, from the County of London Panel Committee, came up for consideration. It was unanimously resolved that this Committee should reply that they were diametrically opposed to every point in the programme of the County of London Panel Committee in this connexion. —I am, etc.,

J. DUFF McCULLOCH,

Honorary Secretary, Bradford Local Medical
and Panel Committee.

December 27th, 1920.

Insurance Medical Records.

SIR,—With the introduction of the new medical records the question will be asked, How can the necessary work be simplified? I have two or three suggestions.

Besides the ordinary guide cards (consisting of the letters of the alphabet) there should be inserted among the records a sufficient number of guides containing the most frequent names on the doctor's list.

Let us consider the records under the name of "Smith," and suppose a doctor has twenty such records in his cabinet. When a patient of this name consults him the record will be removed from the cabinet, the necessary entry will be made, and before it is returned a wire clip will be slipped over the top of the record and the latter replaced. The clip should be kept on the record as long as the patient is under treatment.

A further aid is to insert a long paper knife, or similar object, in the place of the record as it is being withdrawn; the latter is then always put back in the same place. Let us further suppose that at a given time the doctor is treating four patients of the name of "Smith." Each of these records will have a clip on it, and search will only have to be made among four records instead of twenty, which will be a considerable saving of time. When the attendance is completed the clip is removed.—I am, etc.,

Builth Wells, Dec. 23rd, 1920.

W. BLACK JONES.

SIR, I enclose a copy of a letter which I am sending to the local press. I have experienced some hostility to the new medical records on the part of insured persons, on the grounds stated in my letter. It is bad enough to have to keep records one does not want to keep, without this added complication. If some such action were taken generally, it might remove the misapprehension which undoubtedly exists, and would take away one at any rate of the worries with which the Insurance Acts have saddled us.—I am, etc.,

York, Jan. 3rd.

J. C. LYTH.

* * * The letter referred to by Dr. Lyth is signed by him in his capacity as Honorary Secretary of the York Local Medical and Panel Committee; it runs as follows:

It is evident that considerable misapprehension, with resulting apprehension, exists in the minds of the public in regard to the new records required to be kept by insurance practitioners. This is, I believe, largely the result of a campaign engaged in by certain organs of the press, a campaign in which the matter has been dealt with in such a misleading way that it is difficult to avoid the conclusion that some of the misstatements are deliberate.

This would not greatly signify if it were not that medical practitioners are now placed in the unfortunate position of having to keep records, which they do not in many cases wish to keep, and to do so against the will of their patients. Briefly, the principal charge made against the new records is that they will make or may make public portions of a person's private history, which he has always rightly believed would be safe with his doctor.

Now, I do not for a moment desire to be taken as being in favour of the introduction of these records. I have always been against them, and have strenuously resisted their introduction. But the grounds of my resistance have been that I did not think the value of the records commensurate with the extra work involved for the medical practitioners. The value of the records is doubtful, and the extra clerical work considerable. I consider that the time spent on this work could be better employed in trying to cure the diseases which we are asked to tabulate.

But the idea that the records will or may become public in any sense of the term is simply nonsense. If it were so, no medical practitioner would lend himself to the work for an instant.

The record system has been devised with a most careful eye to prevent any such risk, and I think it most important that patients should know this. The records (which, as records, are probably as good as can be devised, if such are to be kept) are, in the first instance, kept by the medical attendant in his own possession. Only on the death or transfer of a patient are they given up to the Insurance Committee.

If this takes place, they are to be delivered in a sealed envelope showing only the name, address, and number of the person concerned. If this person has transferred to another district, or another doctor, the record is then forwarded to the doctor accepting the insured person, who opens the envelope for the first time. He thus has the advantage of seeing what has been the opinion of the original doctor on the case—an advantage which it must surely be obvious is shared equally by the patient. In no circumstances can the record be seen by even the clerical staff of an Insurance Committee; much less can it become public in any sense of the term. The only person other than a panel practitioner who may view the records is the Regional Medical Officer, who may, in his capacity of referee, have occasion to ask for their production. But he also is a medical man, who would require a full knowledge of the case in order to form a just estimate of the insured person's ability to work. To this also no reasonable person can take exception.

Should the keeping of these records prove so onerous as gravely to interfere with adequate time being spent on the more proper duties of panel practitioners, I have no doubt that they will not fail to say so, and it will be for the public then to support them in a refusal to perform such work. But it is worse than futile to deliberately confuse the issue and increase the difficulties of practitioners by creating misgivings in the minds of patients in regard to work which, granted the time to do it in, must necessarily be for their benefit.

SIR,—I have put the following notice in my waiting room and headed it: "Read this: a warning to the insured" —

The Ministry of Health now compels panel doctors to keep records of all the illnesses of the insured. These records will be

inspected, and the record card will be sent to the patient's new doctor when he moves or changes his doctor.

You cannot get away from your record; it will follow you as long as you are insured.

The good old rule that all that is told to the doctor is secret no longer applies to the insured. I think it only fair that insured patients should know of this most important change.

If the Ministry are too many for us, we can at least—and I think it is no less than our duty—warn our ignorant patients what they may expect. They have the votes and the political power not the profession. I hope other doctors will follow my example. I am, etc.,

England's Piece, Yattendon, Berks,
Dec. 19th, 1920.

F. A. BRODRIBB.

"COUNTRY PRACTITIONER" writes: I have just received a bundle of over 900 medical record envelopes tied up with string. After sorting these out I shall have to purchase a special cabinet with alphabetical guides. An enterprising firm has sent me an advertisement of one of these, which I find will cost me about £5. Surely this expense should be covered in some way, either by extra remuneration or else the Insurance Committee should provide receptacles for the cards.

INQUIRY INTO AN INSURANCE PRACTITIONER'S CONDUCT.

WE have received from the Ministry of Health a copy of a letter, dated December 22nd, 1920, addressed to the London Insurance Committee, conveying the Minister's decision in the matter of an inquiry, held on November 16th, 1920, in regard to a London medical practitioner, whose name and address we omit. The report mentioned in the letter has not been forwarded to us.

"I am directed by the Minister of Health to enclose a copy of the report made by the Inquiry Committee appointed by him to consider the representation made by the London Insurance Committee against Dr. A. of B., together with a formal document in which is embodied the decision of the Minister that Dr. A. should not be removed from the medical list, and his direction that the Insurance Committee's costs should be paid by Dr. A.

"With regard to the notice which was exhibited by Dr. A. in his waiting room, and which was of a character seriously to prejudice insurance administration, I am to state that the Minister notes that the practitioner has admitted the impropriety of, and has expressed his regret for, his action in this matter, and, further, that he was in failing health at the time. But for these considerations the Minister would have felt bound to regard the case as one for a severe penalty on the practitioner."

LOCAL MEDICAL AND PANEL COMMITTEES. DURHAM COUNTY.

THE Durham County Medical and Panel Committee, at a meeting held on December 16th, 1920, had under consideration a communication from the Panel Committee for the County of London urging the desirability of replacing the present Insurance Acts Committee by an organization composed entirely of representatives of Panel Committees, together with a communication from the Newcastle-on-Tyne Panel Committee expressing the opinion that such action would be short-sighted and an ill-advised policy. The Durham County Panel Committee expressed agreement with the opinion of the Newcastle-on-Tyne Panel Committee in this matter.

Naval and Military Appointments.

ROYAL NAVAL MEDICAL SERVICE.

THE following appointments are announced by the Admiralty: Surgeon Commanders: W. E. Ormsby, O.B.E., to the *Ramillies*; C. J. O'Connell to the *Fred*, for R.N. Barracks; Surgeon Lieutenant L. S. Goss, O.B.E., to the *Pomona*, for R.N. College, Dartmouth.

ARMY MEDICAL SERVICE.

ROYAL ARMY MEDICAL CORPS.

Major G. W. Heron, D.S.O., O.B.E., relinquishes the acting rank of Colonel.

Major G. R. Panton to be acting Lieutenant-Colonel from July 20th to November 20th, 1920.

Captain Thomas J. E. Thompson, M.C., to be acting Major from January 8th to February 11th, 1919, and from March 20th to April 5th, 1919.

Captain S. Arnott is restored to the establishment.

Temporary Captain W. W. Forbes, O.B.E., relinquishes the acting rank of Major.

The following Lieutenants (Temporary Captains) to be Captains: D. J. H. Jones, T. H. Twigg, J. K. Holland, K. Masson, R. S. Strachan.

The following officers relinquish their commissions: Temporary Lieut. Colonel W. J. N. Vincent, O.B.E., on ceasing to be employed at the Wharfedale War Hospital, and retains the rank of Lieut.-Colonel; Temporary Major J. Dalrymple, C.M.G., O.B.E., and is granted the rank of Lieut.-Colonel; temporary Captain A. G. Welsford, and is granted the rank of Major, September 18th, 1920 (substituted for notification in the *London Gazette* of October 25th, 1920).

INDIAN MEDICAL SERVICE.

Lieut.-Colonel W. M. Anderson has been posted as Chief Medical Officer in the North-West Frontier Province.

Lieut.-Colonel de V. Coudon has been transferred to the temporary non-effective list, September 29th, 1920.

Lieut.-Colonel F. N. Windsor has been permitted to retire, August 15th, 1920.

Lieut.-Colonel L. J. M. Deas has been granted one year combined leave, October 20th, 1920.

Major R. H. Lee has been appointed to officiate as Civil Surgeon, Aimer, and Chief Medical Officer in Rajputana in addition to his own duties as Agency Surgeon, Kotah and Jhalawar, October 26th, 1920.

Major James Jackson Robb (since retired) has been promoted to the rank of Lieutenant-Colonel.

The promotion to present rank of Major Andrew Smith Leslie has been antedated from September 1st, 1918, to March 1st, 1918.

Colonel Percy Charles Hutchison Strickland has been permitted to retire from the service, August 19th, 1920.

Captain M. A. Nicholson was placed under the orders of the Civil Commissioner, Badliad (January 8th, 1919).

Major A. N. Dickson has been posted as Civil Surgeon, Kurram (October 26th, 1920).

Major H. B. Drake, Assay Master, Bombay, has been granted combined leave for twenty months (October 21st, 1920).

Major T. H. G. Oster, I.M.S., has been appointed temporarily as Director, Pasteur Institute, Ransoon.

The following officers have been granted permanent commissions as Lieutenants, with effect from November 1st, 1920, and have been promoted to be Captains from the same date: A. J. D'Souza, M.C., L. S. Modi, K. B. Bharucha, M. G. Bhandari, S. D. Billimoria, M. S. Joshi, R. C. Malhotra, H. A. Khia, S. L. Mitra, N. B. Mehta, M. A. Singh, S. C. Contractor, R. N. Khosla, K. N. Kapadia, M.C., H. S. Rajab, P. R. Vakil, M. L. Dhaswan, B. S. Dondy, A. M. Ghosh, S. Nas, M. T. Khandwala, M. L. Bhargava, T. R. Khandu, G. R. Oberai, J. Chaudra, G. A. Khan, J. E. Dharmibhoy, A. M. V. Hesterlow, M. Prasad, B. B. Gadgil, F. N. Basu, G. R. D. Rai, S. L. Patney, D. N. Bhaduri, R. D. Dani, G. Verghese, B. R. Chaudhari.

The following officers have been granted permanent commissions as Lieutenants, and will retain the temporary rank of Captain, with effect from November 1st, 1920: A. Ba Thaw, I. S. Nalwa, S. G. Mohamed, J. W. F. Albuquerque, G. Kumar, P. M. Antia, R. C. Watts.

TERRITORIAL FORCE.

ROYAL ARMY MEDICAL CORPS.

Temporary Major W. A. Smith, T.D. (4th Battalion East Lancashire Regiment), relinquishes his temporary commission.

Captain C. E. K. Herapath, M.C., to be Major.

To be Captains: Captain A. C. Court, M.C. (late R.A.M.C.S.R.), Captain A. G. M. Middleton, M.C. (late R.A.M.C.), with precedence from December 17th, 1913, and May 23rd, 1918 respectively.

Captain Arthur E. Richmond, O.B.E., R.A.M.C., to be Adjutant of the R.A.M.C. School of Instruction, West Lancashire Division (T.F.).

Captain G. B. Gill to be Major.

Captain P. J. Watkin, M.C. (late R.A.M.C.), to be Captain, with precedence as from April 3rd, 1918.

H. M. Brown (late Devon Regiment), to be Lieutenant.

Super-numerary for Service with the Officers' Training Corps: London University Contingent.—Captain J. H. Ryffel resigns his commission and retains the rank of Captain. Lieutenant D. R. Wheeler (late R.A.M.C.) to be Lieutenant for service with Belfast University Contingent, Senior Division, Officers' Training Corps, with precedence as from May 7th, 1918.

DIARY OF SOCIETIES AND LECTURES.

HARVEIAN SOCIETY OF LONDON, 11, Chandos Street, W.1.—Thurs., 8.30 p.m., Annual General Meeting. Address by retiring President, Dr. W. Hill: The Great Advances in the Investigation and Treatment of Diseases of the Oesophagus during the Present Century (with lantern slides). Conversation.

MEDICAL SOCIETY OF LONDON, 11, Chandos Street, W.1.—Mon., 8.30 p.m., Pathological evening. Specimens and demonstrations by Dr. B. H. Spillsbury, Dr. E. H. Kettle, Dr. E. H. Shaw, Dr. Carnegie Dickson, Dr. A. Fleming, Dr. John Matthews, Dr. Robert Knox, Dr. Crofton Atkins, Dr. Harrison Croft, and Mr. C. A. Clark.

ROYAL SOCIETY OF MEDICINE.—Section of *Psychiatry*: Tues., 8.30 p.m., Dr. Morowoka: The Chord Plexus in Mental Disease. Section of *Neurology*: Thurs., 8.30 p.m., Internal meeting (tea, coffee, smoking). *Clinical Section*: Fri., 5 p.m., Cases. Section of *Ophthalmology*: Fri., 8 p.m., Cases; 8.30 p.m., Dr. Ransom Pridgen: The Size of the Physiological Cup in Relation to Glaucoma; Mr. B. T. Lang: Sclerometry.

SOCIETY FOR THE STUDY OF ISBERNITY, 11, Chandos Street, W.—Tues., 4 p.m., Discussion: Alcohol and Industrial Efficiency, to be opened by Dr. H. M. Vernon.

LONDON DERMATOLOGICAL SOCIETY, 49, Leicester Square, W.C.—Thurs., 6 p.m., Chesterfield Lecture by Dr. J. L. Bunch: Drug Eruptions.

POST-GRADUATE COURSES AND LECTURES.

GLASGOW POST-GRADUATE MEDICAL ASSOCIATION, Western Infirmary.—Wed., 4.15 p.m., Professor Stockman and Mr. Edington: Medical and Surgical Cases.

HOSPITAL FOR SICK CHILDREN, Great Ormond Street, W.C.—Thurs., 4 p.m., Mr. Twistington Higgins: Significance of Lymph.

MANCHESTER: ANCOATS HOSPITAL.—Thurs., 4.30 p.m., Mr. Diggle: Carcinoma of the Larynx.

MANCHESTER ROYAL INFIRMARY.—Tues., 4.30 p.m., Sir William Thorburn: Surgical Treatment of Neuralgia.

MANCHESTER: ST. MARY'S HOSPITALS (Whitworth Street West Branch).—Fri., 4.30 p.m., Dr. Donald: Bladder Symptoms in Gynaecological Practice.

WEST LONDON POST-GRADUATE COLLEGE, Hammersmith, W.—Daily, 10 a.m., Ward Visits: 2 p.m., In- and Out-patient Clinics and Operations. Mon., 12.15 p.m., Dr. Burnford: Pathological Demonstration; 5 p.m., Dr. Saunders: Investigation of Cases with Symptoms of Digestive Trouble. Tues., 12 noon, Mr. Gray: Fractures; 5 p.m., Mr. Davis: Lecture. Wed., 10 a.m., Mr. MacDonald: Genito-urinary; 5 p.m., Mr. Simson: Obstetric Emergencies. Thurs., 2 p.m., Mr. Armour: Operations; 5 p.m., Dr. Taylor: The Circulatory System. Fri., 10 a.m., Dr. McDougal: Electrical; 5 p.m., Mr. Baldwin: Appendicitis. Sat., 12 noon, Mr. Sinclair: Surgical Diseases of Abdomen; 2 p.m., Dr. Owen: Out-patients.

British Medical Association.

OFFICES AND LIBRARY, 429, STRAND, LONDON, W.C.9.

Reference and Lending Library.

THE READING ROOM, in which books of reference, periodicals, and standard works can be consulted, is open to members from 10 a.m. to 6.30 p.m., Saturdays 10 to 2.

LENDING LIBRARY: Members are entitled to borrow books, including current medical works; they will be forwarded, if desired, on application to the Librarian, accompanied by Is. for each volume for postage and packing.

Departments.

SUBSCRIPTIONS AND ADVERTISEMENTS (Financial Secretary and Business Manager): Telegrams: Articulate, Westrand, London). MEDICAL SECRETARY (Telegrams: Medisecra, Westrand, London). Edition, *British Medical Journal* (Telegrams: Aillogis, Westrand, London). Telephone number for all Departments: Gerrard 2630 (3 lines).

SCOTTISH MEDICAL SECRETARY: 6, Rutland Square, Edinburgh. (Telegrams: Associate, Edinburgh. Tel.: 4361 Central.)

IRISH MEDICAL SECRETARY: 36, South Frederick Street, Dublin. (Telegrams: Baedilus, Dublin. Tel.: 4737 Dublin.)

Diary of the Association.

JANUARY.

- 11 Tues. London: Contract Practice Subcommittee, 2.30 p.m.
12 Wed. London: Hospitals Committee, 2 p.m.
London: Propaganda Subcommittee, 2.15 p.m.
14 Fri. London: Ministry of Health Committee, 2.30 p.m.
Border Counties Branch: Lowther Hall, Lowther Street, Carlisle, 3.30 p.m. Demonstration by Major Sinclair on the Treatment of Fractures.
19 Wed. London: Medical Research and Laboratory Workers Subcommittee, 2.30 p.m.
London: University Teachers and Laboratory Workers' Salaries Subcommittee, 4 p.m.
Nottingham Division: General Hospital, Nottingham. Demonstrations by Major Sinclair on Fractures at 2 p.m. and 5 p.m. Tea 4.30 p.m.
20 Thurs. London: Territorial Force Subcommittee, 2.45 p.m.
21 Fri. North of England Branch: Royal Victoria Infirmary, Newcastle-on-Tyne, 2.15 to 4.30 p.m. Clinical Demonstrations.
25 Tues. London: Seruitary Subcommittee, 2 p.m. (Time provisional.)
23 Wed. London: Medico-Political Committee, 2.30 p.m.
28 Fri. London: Central Ethical Committee, 2 p.m.

FEBRUARY.

- 1 Tues. London: Organization Committee, 11 p.m. (Time provisional.)
16 Wed. London: Council, 10 a.m.

APPOINTMENTS.

EDMISTON, J. F., M.B., Ch.B. Liverp., Honorary Assistant Medical Officer, Southport Infirmary.

HARRER, T. H., M.D. Lond., Honorary Assistant Medical Officer, Southport Infirmary.

LITTLE, P. MacDonald, M.C., M.B., Ch.B. Edin., Resident House-Surgeon, Royal Devon and Exeter Hospital.

LOHMER, G. N., M.B., B.S. Melbourne, Medical Registrar, St. Mary's Hospital, Paddington.

STIDSTON, C. A., D.S.O., M.D., B.S. Lond., M.R.C.S., L.R.C.P., Honorary Surgeon to the Wolverhampton and Staffordshire General Hospital, Wolverhampton.

THWAITE, Harold, M.B., B.S. Lond., M.R.C.S., L.R.C.P., Physician to Out-patients to the Birmingham and Midland Free Hospital for Sick Children.

WILSON, A. Cyril, M.R.C.S., L.R.C.P., Senior Assistant Medical Officer to Peckham House and a member of the Special Neurological Clinic, Ministry of Pensions, Grosvenor Gardens.

BIRTHS, MARRIAGES, AND DEATHS.

The charge for inserting announcements of Births, Marriages, and Deaths is 9s., which sum should be forwarded with the notice not later than the first post on Tuesday morning in order to ensure insertion in the current issue.

BIRTHS.

HODDER.—On December 29th, 1920, at Stafford, the wife of Dr. A. E. Hodder—a daughter.

SINCLAIR.—On the 24th December, 1920, at Heathdale, Harborne, Birmingham, to Mr. and Mrs. William Sinclair (née Stephanie P. L. H. T. Daniel, M.B., B.S., M.R.C.S.)—a son.

WOOD.—On December 27th, 1920, at 31, Ightenhill Park Lane, Burnley, the wife of Stanley Wood, M.R.C.S., of a daughter.

MARRIAGE.

DUNLOP—HYSLOP.—On December 28th, 1920, at St. Germain's Church, Edgbaston, Birmingham, by the Rev. R. W. Gibson, M.A., Vicar, James Kirkwood Dunlop, M.A., M.B., Ch.B., Sanghar, Dumfriesshire, to Chrissie Jane, elder daughter of Robert Hyslop, Creetown.

DEATHS.

DOWLING.—On 6th December, 1920, at 93, Bradford Street, Bolton, Rose Mary, the beloved wife of Francis Edward Dowling, L.R.C.S. and P.Ed., etc.

EMMS.—On Christmas Day, at The Cedars, Thurcaston, suddenly, Dr. Emms, late of Belgrave, age 70.

SUPPLEMENT

TO THE

BRITISH MEDICAL JOURNAL.

LONDON: SATURDAY, JANUARY 15TH, 1921.

CONTENTS.

	PAGE
BRITISH MEDICAL ASSOCIATION.	
THE MEDICAL SECRETARY'S VISIT TO LANCASHIRE DIVISIONS	18
ASSOCIATION NOTICES	18
MEETINGS OF BRANCHES AND DIVISIONS	19
ASSOCIATION INTELLIGENCE AND DIARY	20
NAVAL AND MILITARY APPOINTMENTS	19
DIARY OF SOCIETIES AND LECTURES	20

	PAGE
INSURANCE.	
Application by Approved Medical Aid Institution for Extension of Area	17
CORRESPONDENCE.	
INSURANCE MEDICAL RECORDS	13
MEDICAL RECORDS IN COURTS OF LAW	18
APPOINTMENTS... ..	20
BIRTHS, MARRIAGES, AND DEATHS	20

INSURANCE.

APPLICATION BY APPROVED MEDICAL AID INSTITUTION FOR EXTENSION OF AREA.

Those who have studied the various aspects of National Health Insurance will remember that Section 15 (4) of the National Insurance Act, 1911, allowed certain medical aid institutions "existing at the time of the passing of the Act" to receive the approval of the Commissioners, and, under conditions approved by them, to provide medical benefit for their members. This clause was the subject of great controversy at the time, and as first introduced was strongly opposed by the British Medical Association on the ground that not only did it give Government recognition to institutions already existing, but it allowed others to be set up. A compromise was arrived at in a conference between representatives of the Association and of the friendly societies, held in October, 1911, with Mr. Lloyd George in the chair. It was agreed that the "approval" of these societies should be limited to those then existing. This, like most compromises, pleased neither of the sides primarily interested. The almost universal opinion in the medical profession was then, and had been for years, that the medical aid institutions' method of providing medical attendance was bad in principle and had failed in practice. The Medical Alliance, the body representing these institutions, believed in the principle of having salaried doctors under the control of a lay committee, and it naturally fought for the vested interest which it represented.

The rules of the institutions had to receive the approval of the Commissioners, and they can only be changed now with the sanction of the Ministry of Health. The Middlesbrough and District Friendly Societies Medical Aid Association was approved in 1913, and its rules allowed it to operate within three miles of the Middlesbrough Town Hall. The governing body of the institution applied in November, 1919, to be allowed a radius of five miles. The British Medical Association, on hearing of this application, raised strong objection, and the Ministry refused it on the ground that the extension "would have the effect of so widening the scope of the association's activities as to change the character of the institution from that prevailing when it was originally approved." The institution then modified its application, asking to be allowed to take in only the areas of Normanby, Eston, and Grangetown, which are thickly populated industrial areas contiguous to Middlesbrough.

The Ministry decided to hold an inquiry on January 4th, 1921, at Middlesbrough.

Mr. R. W. Harris and Dr. J. Smith Whitaker represented the Ministry, and there were present a number of representatives of the Medical Aid Institution and of the workmen in the area which it was desired to include. These were introduced by Mr. Trevelyan Thompson, one of the members of Parliament for

Middlesbrough, and their views were stated by Mr. Robert Bell, Secretary of the Institute. Mr. Anderson represented the Medical Alliance, with which the Middlesbrough Institute is federated. Mr. Hutton and Mr. Peacock, Chairman and Secretary respectively of the North Riding Insurance Committee, represented that Committee. Mr. Plant, of Messrs. Steavenson and Plant, solicitors, represented the doctors in the area proposed to be included. Dr. G. H. Lowe, Honorary Secretary of the Middlesbrough Panel Committee and of the Cleveland Division of the British Medical Association, represented those bodies, and the Medical Secretary attended for the British Medical Association.

After a few opening remarks by Mr. Harris, who stated the objects of the inquiry, the Medical Secretary inquired whether the North Riding Pharmaceutical Committee had been asked to send representatives, as their interests were obviously involved. Mr. Harris said they had not been summoned, and promised that the point would be kept in mind by the Ministry.

The main argument for the extension, stated very persuasively by Mr. Bell, was that the areas proposed to be included were contiguous to the area already worked by the Institution, and that insured persons who wanted to join it ought not to be debarred by a boundary which was artificial, seeing that the work and interests of the workmen who were already members of the Institution were the same as those of the men just outside; also that it was unfair that they should have to provide for the dependants of insured persons residing in the new area, many of whom were now members, and should be debarred from accepting the insured persons, who were financially a better bargain from the Institution's point of view.

Mr. Plant dealt with the position of the doctors in the area now proposed to be absorbed. He pointed out that the idea of extension came from a body of workmen in that area who had resisted the efforts of the local doctors to obtain an increased weekly payment, and had brought in "doctors of their own" to prevent this increase; that these workmen had found themselves unable to provide medical attendance at a less figure than that suggested by the local doctors, and had had to raise their subscription to at least as high a rate; that the great majority of the workmen had stuck to their old doctors, but that those responsible for introducing the new men were looking to this absorption by the Middlesbrough Institution to stabilize their position by getting the machinery of the Insurance Act behind it. Mr. Plant showed that there was no ground for suggesting that the medical service in the district was not adequate, as there were eight doctors for a population of 30,000, without counting the two new doctors under the control of the workmen; that if the Middlesbrough Institution really believed that they were offering a better service than that given by the private practitioners of the district, there was nothing to hinder them allowing their doctors to go on the North Riding panel, and nothing then to prevent the insured persons in the area now in question choosing those doctors. This point evidently impressed the representatives of the

Ministry, who put searching questions to Mr. Bell and Mr. Anderson as to what difference there would be between the services of their doctors *quæ* medical aid doctors and of the same men *quæ* private insurance practitioners. The only reply seemed to be that the Institute would relieve the doctor of his clerical work, and thus enable him to give a better service than the doctor who had no such machinery at his back. Mr. Plant retorted that any advantage this might give would be far more than counterbalanced by the practical certainty of frequent change of personnel among the Institution doctors.

The Chairman of the North Riding Insurance Committee said that his Committee saw no advantage to the medical service of the district in the extension asked for. He was afraid it would be detrimental to the service, and unfair to the other doctors, inasmuch as the Committee would be unable to allocate to the Institution persons outside the approved radius of the Institution, while the other doctors would be obliged to accept allocations. He stated that there had never been a complaint about the medical service in the area under question during the whole seven years' existence of the service.

The Medical Secretary, after the detailed examination of the local position by Mr. Plant, confined himself mainly to the general aspect of the question, and reminded the representatives of the Ministry of the history of the clause in the 1911 Act which preserved the existence of the medical aid institutions. He said the Association held as strongly as ever that the principle underlying these institutes was bad, and the proof that the profession generally thought so was to be found in the inability of institutes to get doctors, or keep those they wanted to keep. He claimed that an extension of boundary should remove any institution from the category of institutions "existing at the time of the passing of the Act." In this case the part proposed to be included would be more important and richer from the Institution's point of view than the area covered by the parent body. Consent to the proposal would be to allow the less to swallow the greater. If consent were given to the proposal, the fight against these institutions—which had been patched up by the compromise, so far as the then existing bodies were concerned, and so long as they were content with the old position—would be reopened, and the consequences could not fail to be bad for the National Insurance medical service.

Mr. Bell replied, and the representatives of the Ministry stated that the decision of the Ministry would be announced shortly.

CORRESPONDENCE.

Insurance Medical Records.

SIR,—There is a great deal of nonsense written about the record cards and secrecy. As if we should dream of putting down anything on the cards that was really confidential! All we need put down is a clinical note, which not one man or woman in ten thousand, attended in private practice or otherwise, would object to.

There is less publicity in these records than in hospital records. As to the value patients set on keeping their complaints secret, it is instructive to listen for a few moments to the conversation in one's waiting-room. Symptoms and diseases—especially in medical terms, if they can get hold of them—are bandied about with the greatest gusto. And among private patients it is the same. They write to comparative strangers the most glowing description of their most intimate symptoms, and nothing pleases them better than the semi-public discussion of their own and other people's illnesses.

The complaints about the cards are got up, and kept up, by the press—not for the highest reasons. I have tested the trouble of keeping the records, and really it is very little extra work, and we are well paid for it.—I am, etc.,

Fairford, Glos., Jan. 8th.

H. BLOXSOME.

SIR,—It seems curious that neither the Interdepartmental Committee nor anyone at the Ministry of Health has foreseen the advantage which would have accrued if the new record envelopes had been made and printed so that a stiff edge would have been at the top. As at present designed the thin upper edges, which will be constantly fingered, will soon become dog-eared, and probably torn in course of time.

I suggest a better plan would have been to have the opening at the bottom. The record would then be placed in the drawer or cabinet with the open end downwards and the stout edge uppermost; this, as well as making the envelopes more durable, would have greatly facilitated the finding of any individual record. A possible objection

might be that the continuation cards would be in danger of falling out. I find, however, by trial, that this does not happen. An alternative would be to have the opening at the side, but the important point is that a stiff edge should be at the top.

With regard to secrecy: the Ministry have been caught napping in their instructions as to how we are to deal with temporary residents. For these cases we are told to fill in a continuation card and send it to the Local Insurance Committee; but no window envelopes have been issued suitable for this purpose, hence no secrecy.—I am, etc.,

Southport, Jan. 8th.

GEO. R. PENROSE.

SIR,—I have just sent a panel patient to a large city hospital as an "acute abdomen." Unless I worry the staff by post or make a long rail or motor journey to see the patient in hospital, all that I shall know as to the progress and outcome of the case will be the patient's unreliable version on the next occasion I happen to see him. In other words, at a time when the patient is necessarily under non-panel medical care and suffering from a complaint which may colour the whole of his subsequent medical history, no provision is made for maintaining the continuity of his records. The position is manifestly absurd, and when appreciated by the opponents of the record system will furnish them with a much more deadly weapon than the "secrecy stunt."—I am, etc.,

WM. J. AITKEN QUINE, M.B., B.S., D.P.H.

Chinley, Jan. 9th.

Medical Records in Courts of Law.

SIR.—It appears to have been overlooked by all concerned that various and far-reaching legal problems may arise by the demand of the courts of law for the production of these record cards in court. A late Master of the Rolls, Sir George Jessel, laid it down that the courts of law do not recognize professional secrecy between a doctor and his patient, and this view was upheld by the House of Lords, and therefore any judge can demand the production of these cards in court if he thinks fit. The cards will practically be a life-history of insured people, giving their age, changes of occupation and changes of address, in addition to the history of their diseases. Up to the present all citizens are supposed to stand equal before the law; now they will be divided into two classes in their relation to the law courts: one class of the community will be liable to have the records of their life-histories produced in open court and the other class will be immune from this publicity.—I am, etc.,

Stalybridge, Jan. 9th.

ADAM FOX, L.R.C.P., L.R.C.S.

British Medical Association.

THE MEDICAL SECRETARY'S VISIT TO LANCASHIRE DIVISIONS.

THE Honorary Secretary of the Lancashire and Cheshire Branch, Mr. F. Strong Heaney, has arranged the following series of Division meetings to be addressed by the Medical Secretary in the week beginning January 17th:

Monday, January 17th.—Evening: Ashton-under-Lyne.

Tuesday, January 18th.—Afternoon: Mid Cheshire, Evening: Stockport, Macclesfield and East Cheshire, and Hyde.

Wednesday, January 19th.—Afternoon: Liverpool and Birkenhead.

Thursday, January 20th.—Afternoon: Salford. Evening: Blackpool.

Friday, January 21st.—Afternoon: St. Helens. Evening: Wigan.

On Wednesday evening Dr. Cox will be the guest of the St. Helens Medical Society at its annual dinner. The Chairman of Representative Meetings, Dr. T.W. H. Garstang, hopes to accompany the Medical Secretary to most of the meetings.

Association Notices.

BRANCH AND DIVISION MEETINGS TO BE HELD.

METROPOLITAN COUNTIES BRANCH: WILLESDEN DIVISION.—A meeting of the Willesden Division (open to non-members) will be held at St. Andrew's Parish Hall on Tuesday, January 18th, at 8.30 p.m. Dr. Christine Murrell will read a paper on maternity and child welfare clinics.

METROPOLITAN COUNTIES BRANCH: HARROW DIVISION.—A meeting of the Harrow Division will be held on January 25th at the Gayton Rooms, Harrow, when Dr. Crichton-Miller will read, at 9 p.m., a paper on toxins, endocrines, and emotives.

MIDLAND BRANCH: NOTTINGHAM DIVISION.—Major Sinclair, C.M.G., R.A.M.C., will give a demonstration on "Fractures" in the General Hospital, Nottingham, on Wednesday, January 19th, starting at 2 p.m. At 4.30 an adjournment will be made to 64, St. James's Street, Nottingham, for tea, at the invitation of the Nottingham Medico-Chirurgical Society. At 5 p.m. Major Sinclair will give a lantern slide demonstration, illustrating his previous demonstration. All members of the Association are cordially invited to be present at this demonstration. Major Sinclair has kindly offered to repeat this demonstration the following day for the benefit of the nursing sisters of the Nottingham and neighbouring general hospitals.

Meetings of Branches and Divisions.

VICTORIAN BRANCH.

At the close of the year the ballot papers were issued for the election of the new Branch Council. With the end of the Lodge dispute now in view, the incoming Council will be free from the heavy labours attaching to this question, and will be able to devote its energies in other directions. The situation at present is that nine large Orders, as well as certain smaller Friendly Societies, are working in harmony with the British Medical Association on the basis of the Wasley award. Three only have definitely refused to accept the terms of the British Medical Association.

Revision of Rules.

One of the many important subjects considered by the Council in 1920 was that of the revision of the rules. It had been recognized for some time that the time was ripe for such revision, but action in respect of the rule governing the annual subscription was rendered imperative by legislation passed at the Representative Meeting held at Cambridge last June, by which the annual contribution from Overseas Branches was raised to £22s. per member. The Council submitted to a special meeting of the Branch a proposal that the rates of subscription be four guineas for town members, three and a half guineas for country members, and two and a half guineas for junior members. Of these amounts, £2 2s., £1 11s. 6d., and 10s. 6d., respectively, were allotted to the Medical Society of Victoria. The Branch endorsed the suggestions of the Council regarding the increased subscription, though not without expressions of protest from various members who considered that the additional subscription asked of overseas members was scarcely warranted.

Another important change arising out of the revision of the rules is that the Council, elected by the members of the Branch, will in future select its own office-bearers. Hitherto the officers have been chosen by a general ballot of the members. There will be a Chairman of Committees, also selected by the Council, who, it is anticipated, will hold office for several consecutive years at least, and thus be conversant with the details of the activities of the retiring Council. There will also be representatives on the Council selected by the Divisions in town and country. This policy is designed to ensure greater strength to the Council, and to facilitate exchanges of views between the Council and the various Divisions; the change was suggested by experience in the recent Lodge dispute, when it was found that the presence of the local secretaries of Divisions on the Organization Committee was of the greatest assistance.

Parliamentary Representatives.

The election of Dr. J. R. Harris to the Legislative Council and of Dr. Stanley S. Argyle to the Legislative Assembly of the Victorian State Parliament are matters for congratulation. These gentlemen were entertained at dinner by the members of the Victorian Branch at the Grand Hotel, Melbourne, on November 25th, to mark their entry into Parliament. The medical profession in Victoria now feel that their views will be laid authoritatively before Parliament, and that misrepresentations of the opinions and attitude of the British Medical Association, some of which are matters of recent experience, will in future not go uncorrected.

Branch Honorary Secretary.

The Council has placed on record its very great appreciation of the services rendered the Association by Dr. J. W. Dunbar Hooper, during his four years' tenure of office as Honorary Secretary to the Victorian Branch. Dr. Hooper carried out the duties of honorary secretary during a particularly stressful term, which embraced almost the whole of the war period and that of the Lodge dispute. Only when the latter was fairly settled did he feel free to resign from the office which had absorbed such a large

amount of his time at a very great personal sacrifice. Dr. E. L. Davies was appointed as honorary secretary in succession to Dr. Hooper.

Post-graduate Classes.

The first series of post-graduate classes, arranged by the Permanent Committee for Post-graduate Work, established on the initiative of the Council of the British Medical Association, was held during the fortnight commencing November 8th, 1920. All the teaching hospitals, the Faculty of Medicine, the Walter and Eliza Hall Institute of Medical Research, and the Commonwealth Serum Laboratories co-operated, and the classes were well attended. The inaugural lecture on "Instruments of precision in diagnosis," was delivered at the University of Melbourne by Professor W. A. Osborne.

METROPOLITAN COUNTIES BRANCH: CITY DIVISION.

A DIVISIONAL dinner—the first since pre-war days—was held at the Abercorn Rooms, Great Eastern Hotel, on January 6th when Dr. CUTHBERT DIXON presided.

Dr. E. Goodall, President of the Branch, will deliver an address to the Division at the Metropolitan Hospital on Thursday, January 27th, at 9 p.m., on the nervous group of the acute infectious diseases.

A dinner dance has been arranged at the Abercorn Rooms on March 31st.

ULSTER BRANCH: BELFAST DIVISION.

At the opening meeting of the Belfast Division of the British Medical Association, a paper, perhaps most instructive from the point of view of diagnostic argument, was read by Dr. ROBERT REID, of Whiteabbey, Belfast, Chairman of the Division, on some interesting cases in general practice. A vote of thanks was accorded Dr. Reid, on the proposition of Colonel A. FULLERTON, seconded by Dr. R. W. LESLIE.

Naval and Military Appointments.

ROYAL NAVAL MEDICAL SERVICE.

The following appointments are announced by the Admiralty: Surgeon Commanders: E. S. Miller to the *Warspite*, P. H. Boyden to the *Dryad*, W. L. Martin, O.B.E., to R.M. Depot, Deal, A. R. Thomas, O.B.E., and E. D. J. O'Malley, to the *Valiant*, R. H. Mornement, O.B.E., to R.M.A., Eastney, W. P. Walker to the *Indefatigable*, J. W. Craig to the *President* for R.N. College and Hospital School, Greenwich (temporary). Surgeon Lieut. Commander H. R. Bull to the *Raleigh* on commissioning. Surgeon Lieutenants: F. L. H. MacDowel to Special R.M. Battalion, J. R. Brennan to the *Cruace*.

ARMY MEDICAL SERVICE.

The following Major-Generals retire on retired pay: Louis E. Anderson, C.B., June 3rd, 1920 substituted for notification in the *London Gazette*, May 10th, 1920; Gerald Cree, C.B., C.M.G.

ROYAL ARMY MEDICAL CORPS.

The following are placed on the half-pay list on account of ill health: Lieut.-Colonel G. J. S. Archer, Major H. S. Dickson.

The following relinquish the acting rank of Major: Temporary Captain Robert B. Wallace, D.S.O., M.C., Captain and Brevet Major J. D. Bowie, D.S.O.

Captain W. Walker, M.C., to be acting Major.
To be temporary Captains, Temporary Lieutenant H. J. Brink, E. Tanton (late temporary Captain with seniority from September 29th, 1915).

J. A. B. Sim to be temporary Lieutenant.

The following officers relinquish their commissions: Temporary Major W. A. Brend, December 11th, 1917, and retains the rank of Major (substituted for the notification in the *London Gazette* of December 10th, 1917). Temporary Captains and retain the rank of Captain: O. V. Burrows, M.C., E. H. Cleveland, J. A. MacSweeney, S. Wigglesworth, W. Kingdon, G. Fildes, R. Stephens. Temporary Captains on appointment to the Indian Medical Service: P. A. Dargan, H. J. H. Symons, M.C. Temporary Lieutenant D. M. O'Dwyer, and retains the rank of Lieutenant.

ROYAL AIR FORCE.

MEDICAL BRANCH.

Wing Commanders to be Group Captains: D. Munro, C.I.E., with effect from December 31st, 1920; N. J. Roche, O.B.E., R. V. Wells, C.B.E.

Squadron Leader to be Wing Commander: J. MacGregor, M.C.
Flight Lieutenants to be Squadron Leaders: T. J. Kelly, M.C., R. S. Overton.

INDIAN MEDICAL SERVICE.

Major J. A. Shorten, Professor of Physiology, Medical College, Calcutta, has been granted combined leave for seven months (December 1st, 1920).

Colonel J. B. Smith, C.B., K.H.P., has been promoted to the rank of Major-General (June 26th, 1920).

The following officers have been permitted to retire, with effect from the dates noted: Major-General H. H. Hendley, M.D., K.H.S. (June 26th, 1920). Lieut. Colonel F. N. Windsor, M.B. (August 15th, 1920). Major H. C. Brown, C.I.E. (October 23rd, 1920).

The promotion to present rank of Major H. Stout, O.B.E., M.D., has been antedated from August 1st, 1920, to February 1st, 1920.

The following Colonels have been appointed Honorary Surgeons to His Majesty the King: C. R. M. Green (June 15th, 1920), J. Garvie (June 20th, 1920).

The services of Captain J. H. Horne, M.B., have been placed temporarily at the disposal of the Chief Commissioner, Assam.

Major E. C. Taylor has been granted combined leave for one year (September 15th, 1920).

Major C. B. McConaghy has been appointed to hold charge of the current duties of the office of Political Agent, Bhopal, in addition to his own (November 19th 1920).

Captain (Brevet Major) T. A. Hughes, appointed to be Professor of Physiology, King Edward Medical College, Lahore (October 25th, 1920).

Major M. R. C. MacWatters, Professor of Surgery, King George's Medical College, Lucknow, has been granted combined leave for one year (November 3rd, 1920).

Major H. Halliday, Civil Surgeon, Simla West, has been granted privilege leave for six months (November 10th, 1920).

Major (Brevet Lieut.-Colonel) F. A. F. Burnardo, C.B.E., C.I.E., Civil Surgeon, Simla East, appointed to hold charge of the duties of the Civil Surgeon, Simla West.

Major R. F. D. MacGregor has been posted as Medical Officer, Sistan Consulate (December 12th, 1920).

Lieut.-Colonel H. Anstey Smith, C.I.E., M.B., has been promoted to the rank of Colonel (April 19th, 1920).

To be Lieutenants (April 24th, 1920): E. T. N. Taylor, M.B., A. S. Garewal, A. V. Lopes.

SPECIAL RESERVE OF OFFICERS.

ROYAL ARMY MEDICAL CORPS.

Lieut.-Colonel J. H. P. Graham relinquishes his commission and retains the rank of Lieut.-Colonel.

TERRITORIAL FORCE.

ROYAL ARMY MEDICAL CORPS.

Major M. J. Mahoney, D.S.O., resigns his commission and retains the rank of Major.

Captain J. Ramsay, O.B.E., to be Major.

Captain G. R. E. G. Mackay, M.C., resigns his commission and is granted the rank of Major.

To be Captains: Captain J. Paton (late R.A.M.C.), with precedence as from April 1st, 1915 (October 14th, 1920—substituted for notification in the *London Gazette* of October 20th, 1920); Captain T. M. Jamieson from 4th Southern General Hospital, with precedence as from June 4th, 1915.

Captain L. R. G. de Granville to be Lieutenant, with precedence as from February 27th, 1915, and to relinquish the rank of Captain.

1st *London (C. of L.) Sauxitary Company*.—Major L. T. F. Bryett, T.D. resigns his commission and retains his rank, with permission to wear the prescribed uniform.

Supernumerary for Service with the O.T.C.—Temporary Captain V. G. L. Fielden, resigns his commission and retains the rank of Captain.

TERRITORIAL FORCE RESERVE.

ROYAL ARMY MEDICAL CORPS.

Captains W. C. Hodges and E. G. Annis resign their commissions, and are granted the rank of Major.

DIARY OF SOCIETIES AND LECTURES.

HUNTERIAN SOCIETY, Stion College, Embankment, E.C.—Wed., 9 p.m.: Lecture by Sir W. Arbuthnot Lane on Colectomy.

LONDON DERMATOLOGICAL SOCIETY, 49, Leicester Square, W.C.2.—Tuesday, 4.30 p.m.: Pathological Specimens and Cases.

MEDICO-LEGAL SOCIETY, 11, Chandos Street, W.1.—Tuesday, 8.30 p.m., Dr. H. G. Sutherland; Medical Evidence in the Stanton Murder Trial.

ROYAL SOCIETY OF MEDICINE.—General Meeting of Fellows, Tues., 5 p.m. *Section of Therapeutics and Pharmacology*: Tues., 4.30 p.m., Laboratory Meeting at the National Institute for Medical Research, Hampstead. Presidential Address by Dr. H. H. Dale: Tendencies in Chemotherapy; Dr. J. H. Burn: Comparison of Digitalis Tinctures; Demonstrations. *Section of Pathology*: Tues., 8.30 p.m., Sir G. Lenthal Cheatle: Carcinoma of Breast; Dr. J. A. Murray: Early Carcinoma in the Mouse Mammary; Mr. A. H. Drew: Amitosis and Mitosis. *Section of History of Medicine*: Wed., 5 p.m., Dr. O. C. Gruner: The *De Viribus of Avicenna*; Dr. W. J. Turrell: Electro-therapists of the Eighteenth Century. *Section of Dermatology*: Thurs., 4.30 p.m., Cases. *Section of Otolaryngology*: Fri., 4.45 p.m., Cases; 5 p.m., Mr. T. Ritchie Rodger: Cavernous Sinus Thrombosis. *Section of Electro-Therapeutics*: Fri., 8.30 p.m., Dr. W. J. Turrell: Therapeutic Activity of Galvanic Current.

POST-GRADUATE COURSES AND LECTURES.

GLASGOW POST GRADUATE MEDICAL ASSOCIATION, Royal Infirmary.—Wed., 4.15 p.m., Drs. Cowan and J. K. Reubie: Modern Treatment of Diabetes.

MANCHESTER ROYAL INFIRMARY.—Tues., 4.30 p.m., Dr. E. S. Reynolds: Apbasia.

MANCHESTER: ST. MARY'S HOSPITALS (WHITWORTH STREET WEST BRANCH).—Fri., 4.30 p.m., Dr. Lapage: Vomiting in New-born and Young Infants.

NATIONAL HOSPITAL FOR DISEASES OF THE HEART, Westminsterland Street, W.1.—Mon., 5.30 p.m., Dr. Parsons-Smith: Mitral Stenosis.

NORTH OF ENGLAND BRANCH, BRITISH MEDICAL ASSOCIATION, Royal Victoria Infirmary, Newcastle-on-Tyne.—Fri., 2.15 p.m., Mr. F. C. Pybus: Tuberculosis of the Spine; 2.45 p.m., Mr. J. Clay, O.B.E.: Urethral Obstruction; 3.15 p.m., Dr. A. Parkin: Clinical Cases; 3.45 p.m., Tea; 4 p.m., Dr. R. A. Bolam, O.B.E.: Dermatological Cases.

SALFORD ROYAL HOSPITAL.—Thurs., 4.30 p.m., Dr. Langley: Diagnosis of Diseases of the Liver.

WEST LONDON POST-GRADUATE COLLEGE, Hammersmith, W.—Daily, 10 a.m., Ward Visits; 2 p.m., In- and Out-patient Clinics and Operations. Mon., 2 p.m., Dr. Stewart: Out-patients; 5 p.m., Dr. Saunders: Digestive Disturbances of Children. Tues., 10 a.m., Mr. Steadman: Dental; 5 p.m., Dr. Burnford: Physiology of Digestive Tract. Wed., 11 a.m., Mr. MacDonald: Cystoscopy; 5 p.m., Dr. Simson: Obstetric Emergencies. Thurs., 2 p.m., Mr. Bishop Harman: Eyes; 5 p.m., Professor H. Littlejohn: Medico-legal *Post-mortem* Examination of a Newly-born Infant. Fri., 2.30 p.m., Mr. Addison: Wards; 5 p.m., Mr. Baldwin: Appendicitis. Sat., 12 noon, Mr. Sinclair: Diseases of Abdomen; 2 p.m., Dr. Owen: Out-patients.

British Medical Association.

OFFICES AND LIBRARY, 49, STRAND, LONDON, W.C.2.

Reference and Lending Library.

THE READING ROOM, in which books of reference, periodicals and standard works can be consulted, is open to member from 10 a.m. to 6.30 p.m., Saturdays 10 to 2.

LENDING LIBRARY: Members are entitled to borrow books including current medical works; they will be forwarded if desired, on application to the Librarian, accompanied by 1s. for each volume for postage and packing.

Departments.

SUBSCRIPTIONS AND ADVERTISEMENTS (Financial Secretary and Business Manager, Telegrams: Articulate, Westrand, London); MEDICAL SECRETARY (Telegrams: Medisecura, Westand, London); EDITOR, *British Medical Journal* (Telegrams: Aitiology, Westrand, London).
Telephone number for all Departments: Gerrard 2630 (3 lines).

SCOTTISH MEDICAL SECRETARY: 6, Rutland Square, Edinburgh (Telegrams: Associate, Edinburgh. Tel.: 4361 Central).

IRISH MEDICAL SECRETARY: 16, South Frederick Street, Dublin (Telegrams: Breillus, Dublin. Tel.: 4737 Dublin.)

Diary of the Association.

JANUARY.

- 14 Fri. London: Ministry of Health Committee, 2.30 p.m.
18 Tues. Willesden Division, St. Andrew's Parish Hall, High Road, Willesden Green, N.W., 8.30 p.m.
19 Wed. London: Medical Research and Laboratory Workers Sub-committee, 2.30 p.m.
London: University Teachers and Laboratory Workers' Salaries Sub-committee, 4 p.m.
Nottingham Division: General Hospital, Nottingham. Demonstrations by Major Sinclair on Fractures at 2 p.m. and 5 p.m. Tea 4.30 p.m.
20 Thurs. London: Territorial Force Sub-committee, 2.45 p.m.
21 Fri. North of England Branch: Royal Victoria Infirmary, Newcastle-on-Tyne, 2.15 to 4.30 p.m. Clinical Demonstrations.
25 Tues. London: Scrutiny Sub-committee, 2 p.m. (Time provisional.)
Harrow Division, Gayten Rooms, Harrow, 9 p.m.
26 Wed. London: Journal Committee, 2.30 p.m.
London: Medico-Political Committee, 2.30 p.m.
27 Thurs. London: Insurance Acts Committee, 2.30 p.m.
City Division, Metropolitan Hospital, 9 p.m.
28 Fri. London: Central Ethical Committee, 2 p.m.

FEBRUARY.

- 1 Tues. London: Organization Committee, 11 a.m.
London: Grants Sub-committee, 10.30 a.m.
2 Wed. London: Finance Committee, 2.30 p.m.
4 Fri. London: Naval and Military Committee, 2.30 p.m.
16 Wed. London: **Council**, 10 a.m.

APPOINTMENTS.

MARSHALL, W. H., M.R.C.S., L.R.C.P., House-Physician, West London Hospital, Hammersmith, W.

MOORE, C. A., M.S.Lond., Ch.M., F.R.C.S., Surgeon to the Bristol General Hospital.

WAYTE, J. W., M.B., B.S.Lond., Junior Medical Officer and Registrar, Croydon General Hospital.

EDINBURGH ROYAL INFIRMARY.—The following appointments have been made:—*Resident House-Physician*: T. R. R. Todd, M.B., Ch.B., to Professor Sir Robert Philip. *Resident House-Surgeons*: E. H. Aultlett, M.B., Ch.B., to Sir David Wallace; W. D. Brunton, M.B., Ch.B., to Mr. A. A. Scott-Skiving; D. A. Miller, M.B., Ch.B., to Mr. N. T. Brewis; T. E. Hastings, M.B., Ch.B., and Charles Simpson, M.B., Ch.B., to Surgical Out-Patient Department, under Mr. Chiene. *Clinical Assistant*: Major A. G. Coullie, M.B., Ch.B., F.R.C.S.E., I.M.S., to Dr. Norman Walker.

HAMPSHIRE GENERAL AND NORTH-WEST LONDON HOSPITAL.—*House-Physician*: Philip Hudson, M.B., B.S.Lond., *House-Surgeon*: Roland H. Fulton, M.B., Ch.B., New Zealand. *Casualty Medical Officer*: G. S. Lawrence, M.A., M.B., Ch.B., Aberd. *Casualty Surgical Officer*: W. A. Miller, D.S.O., M.C., M.B., Ch.B., Edin.

BIRTHS, MARRIAGES, AND DEATHS.

The charge for inserting announcements of Births, Marriages, and Deaths is 9s., which sum should be forwarded with the notice not later than the first post on Tuesday morning in order to ensure insertion in the current issue.

BIRTHS.

BOURHILL.—At Wynford, Pentre Broughton, near Wrexham, on January 1st, 1921, to Dr. and Mrs. C. J. G. Bourhill—a son.

MARSHALL.—At a nursing home, Manchester, on Friday, January 7th, the wife of H. F. Marshall, F.R.C.S.E. (nee Christian Haig Ferguson), of a daughter.

MARRIAGE.

PARSONS—DAWNEY.—On January 3rd, 1921, at the Church of St. Mary-le-Park, Battersea, Christopher Thackray Parsons, O.B.E., M.D. Lond., to Annie Burgess, widow of Archibald Hugh Payau Davuay, F.R.C.S.

DEATHS.

FOX.—On January 4th, at Thornleigh, Accrington, Dr. Michael John Fox, V.D., J.P., aged 74 years.

Requiescat in pace.

HAMILTON.—On January 1st, at Essex House, Barnes, Henry Thomas Hamilton, L.R.C.P.L., L.S.A., J.M., son of the late Dr. Henry Hamilton, of Hatfield House, Chilham, aged 63 years.

HIGGINS.—On December 28th, 1920, suddenly, Charles Higgins, Consulting Ophthalmic Surgeon to Guy's Hospital.

SUPPLEMENT

TO THE

BRITISH MEDICAL JOURNAL.

LONDON: SATURDAY, JANUARY 22ND, 1921.

CONTENTS.

	PAGE			PAGE
BRITISH MEDICAL ASSOCIATION		INSURANCE.		
CURRENT NOTES:		EXPENDITURE AND INCOME STATISTICS	...	22
MEMBERSHIP OF THE ASSOCIATION	21	SANATORIUM BENEFIT IN SCOTLAND	...	23
APPLICATION BY APPROVED MEDICAL AID INSTITUTION FOR EXTENSION OF AREA	21	CORRESPONDENCE:		
UNEMPLOYMENT INSURANCE ACT AND DOCTORS' DOMESTIC SERVANTS	21	SUPPLY OF DRUGS IN RURAL AREAS	...	23
MEMBERS OF LONG STANDING OR RETIRED FROM PRACTICE	21	INSURANCE MEDICAL RECORDS	...	23
THE ENCEPHALITIS LETHARGICA SCHEDULE IN LONDON	21	NAVAL AND MILITARY APPOINTMENTS		
THE HOSPITALS COMMITTEE	21	DIARY OF SOCIETIES AND LECTURES	...	24
THE CONTRACT PRACTICE SUBCOMMITTEE	22	APPOINTMENTS...	...	24
ASSOCIATION NOTICES	22	BIRTHS, MARRIAGES, AND DEATHS	...	24
ASSOCIATION INTELLIGENCE AND DIARY	24			

British Medical Association.

CURRENT NOTES.

Membership of the Association

BETWEEN January 1st and January 11th of the present year 444 new members have joined the British Medical Association.

Members of Long Standing or Retired from Practice.

The Council is recommending the Representative Body to reduce to two guineas the membership sub-scription in the case of members of forty years' standing, and also in the case of members of not less than ten years' standing retired from practice. If approved by the Annual Representative Meeting at Newcastle, these changes would in the ordinary way become effective as from January 1st, 1922, but the Council hopes to find means by which they can, if approved, be made retrospective for the current year.

Application by Approved Medical Aid Institution for Extension of Area

With reference to the report published in the SUPPLEMENT last week of an application for extension of area by the Middlesbrough and District Friendly Societies Medical Aid Association, we are informed by the Ministry of Health that the application has been refused. This news will be welcomed not only by the local members of the medical profession, who are principally concerned, but by all those practising in areas in which such institutions exist. As the Medical Secretary informed the representatives of the Ministry at the inquiry, the British Medical Association is willing to respect the compromise arrived at whereby those institutions which were approved at the beginning of the operation of the Insurance Act shall be tolerated so long as they are content to remain "as existing at the time of the passing of the Act." But, believing as it does that the principle on which these institutions are based is entirely wrong, the Association is bound to prevent by every means in its power any extension of their activities.

Unemployment Insurance Act and Doctors' Domestic Servants.

In November last the British Medical Association approached the Ministry of Labour upon the relation to the Unemployment Insurance Act of domestic servants employed by medical practitioners. A test case was put up by Dr. X. for a ruling as to whether or not L. N., a domestic servant, who also attends to the surgery door to admit and show out patients during consulting hours, is an employed person within the meaning of the Act. Dr. Courtenay Lord represented the Association, by invitation of the

Ministry of Labour, when the case was under consideration. The ruling of the Minister is to the effect that the said employment is not such as to make the said L. N. an employed person within the meaning of the said Act. In the covering letter the Ministry states "the decision will cover in principle all persons employed in the same occupation provided that the conditions are precisely similar." It is understood that a decision with regard to doctors' chauffeurs will be communicated to the Association without delay.

The Encephalitis Lethargica Schedule in London.

A member of the Association practising in London has forwarded copies of correspondence which has passed lately between the medical officer of health and himself regarding a schedule of inquiry on notified cases of encephalitis lethargica issued by the London County Council. This schedule includes a series of thirteen questions about the symptoms, etc., of the patient, with spaces for "results of blood tests or bacteriological examinations," "results of *post mortem* examination." One question has eight subheads on symptomatology—namely, "fever; lethargy; ptosis, squint, nystagmus; facial paralysis; paralysis or paresis of particular muscles of the trunk or limbs or sphincters; mental condition; delirium, tremors, or other nervous symptoms; speech changes." On receiving this schedule, the completion of which demands a good deal of time and the application of recent knowledge, the medical man asked what would be the fee for so doing. The answer was to the effect that no fee was payable, but that the medical officer of health would write (so far, we gather, with no result) to the London County Council on the matter. The medical officer of health added that these forms had been filled up by doctors all over London for some considerable time, and that this was the first occasion on which he had had difficulty in obtaining the information. That this should be so is a credit to the public spirit of London practitioners, but does not speak very well for their acumen. The delay in restoring, not to mention increasing, the notification fee for infectious diseases in general may, however, have accustomed the profession to exploitation at the hands of public bodies.

The Hospitals Committee.

The Hospitals Committee of the Association met on January 12th, and considered, amongst other matters, the following:

Payment of Members of Staffs of Voluntary Hospitals.—The Committee is collecting information as to the methods of payment of medical staffs of voluntary hospitals in respect of State- or rate-maintained and other "paying" patients in voluntary hospitals, and will be glad to receive details of any scheme in force of which it has not already been notified; the Committee has also appointed a sub-

committee to meet a subcommittee of the British Hospitals Association to discuss the question of obtaining increased payment from the Ministry of Pensions for hospitals, and any other relevant questions arising out of the Conference of Representatives of Voluntary Hospitals held on December 21st, 1920.

Conference of Representatives of Medical Staffs of Voluntary Hospitals.—Arising out of the Conference of Representatives of Medical Staffs of Voluntary Hospitals, held on December 21st, 1920, the Hospitals Committee has appointed a small subcommittee to prepare a statement of evidence for submission, on behalf of the British Medical Association, to the Committee appointed by the Minister of Health "to inquire into and report upon the financial position of the voluntary hospitals throughout the country and to make recommendations." This statement of evidence will be submitted to the Hospitals Committee for approval and will be finally decided upon at its next meeting.

Utilization of Poor Law Hospitals.—The Committee is also considering the question of the utilization of spare beds in Poor Law infirmaries for augmentation of voluntary hospitals. The Committee is well aware that suggestions to this effect have been made in several areas, and would be glad to be informed of the details of any scheme, other than those already notified, in order that the information may be utilized for a memorandum which is being prepared for consideration at its next meeting.

The Contract Practice Subcommittee.

The Contract Practice Subcommittee met on January 11th. A number of reports were received from areas which had recently adopted revised scales for attendance on uninsured persons at contract rates. The Subcommittee notes with regret that there is still a marked tendency to accept a much lower fee for persons up to the age of 16 than for adults. The question of mileage in connexion with coroners' inquests was considered, and it was decided to recommend the Medico-Political Committee to approach county councils with a view to inducing them to pay mileage, as is being done in the case of Montgomeryshire. The question of fees for certifying factory surgeons was under discussion, and it was decided to recommend the Medico-Political Committee to co-operate with the Association of Certifying Factory Surgeons in a renewed effort to get these fees placed on a more satisfactory basis. That Committee was asked also to consider the increased telephone rates as they affect medical men.

Association Notices.

BRANCH AND DIVISION MEETINGS TO BE HELD.

METROPOLITAN COUNTIES BRANCH: HARROW DIVISION.—A meeting of the Harrow Division will be held on January 25th at the Gayton Rooms, Harrow, when Dr. Crichton-Miller will read, at 9 p.m., a paper on toxins, endocrines, and emotions.

INSURANCE.

EXPENDITURE AND INCOME STATISTICS.

As insurance practitioners are already aware, it is necessary to be in a position to justify any application that may be made to the proper authorities by the Insurance Acts Committee for increase in remuneration for work under the Insurance Act, on the grounds of increased practice expenses. The difficulty experienced by a medical practitioner in adopting a compound system of keeping his accounts has been a source of embarrassment to the British Medical Association in collecting statistics of expenditure and income at times when such information has been urgently required for furthering the interests of practitioners in their relations with Governmental and other bodies. A form for collection of statistics to be furnished by individual practitioners was sent in June, 1920, to Panel Committees, with a request that it should be distributed to those practitioners who could be relied upon to keep the figures and send them for the confidential use of the Insurance Acts Committee. These statistics, incidentally, are desired now, and should be forwarded to the Medical Secretary of the Association. As a result of the experience gained and the criticisms of that form, the Committee has drawn up a new form designed

by practitioners who understand and fully appreciate both the individual practitioner's and the Association's requirements. This is believed to be a considerable improvement on the old form, and should be found very useful to all practitioners who wish to keep particulars of their income and expenditure on a simple plan, irrespective of whether they place the schedule at the temporary disposal of the Committee or not. Practitioners are assured that the information supplied will be treated as strictly private and confidential, and will be used with great discretion; the names of individuals will not be disclosed even to the Insurance Acts Committee.

Description of the Form.

The form consists of a series of interleaves, with cash columns lettered to correspond with the various sections of expenditure and income, contained within a stiff cover. There are four divisions into which the columns of expenditure and income fall: wholly professional expenses, partly professional expenses, non-professional expenses, and professional income. It includes:

WHOLLY PROFESSIONAL EXPENSES.

(Note.—The whole of these expenses are deductible for income tax.)

Surgery Expenses.

Drugs, bottles, etc., carriage and delivery of medicines.
Salary of dispenser.
Branch surgery and establishment expenses applicable thereto.

Personal Expenses.

Professional books and journals.
Subscriptions to professional societies.
Instruments.
Laboratory and other fees.

Miscellaneous Expenses.

Professional stationery, postages, telegrams, etc., telephone.
Commissions on debt collecting, etc., sundries.

Salary of Assistant or Locumtenent.

Travelling.

Professional rail, cab fares, etc.
Motors, horses, etc.: (a) hire; (b) running expenses and repairs, including insurance; (c) wages and livery; (d) purchase and sale.

PARTLY PROFESSIONAL EXPENSES.

(Note.—A part of these expenses, usually one-third, but possibly up to two-thirds, is deductible for income tax.)

Establishment Expenses.

Rent or annual value of house; rates, house duty, etc.; repairs; fuel and light; fire insurance; servants' wages and insurance; household cleaning materials.

NON-PROFESSIONAL EXPENSES.

Household Expenses.

Provisions for whole household (in households where garden, dairy, pig, or poultry produce are self-supplied the value of these should be added); beverages, laundry, clothing (for whole household under each item); household replenishment; household sundries.

Personal.

Sundries (books, postage, stationery, etc.); private expenditure; life and other insurance premiums.
Education.
Holidays.
Income tax and other taxes not previously entered.

PROFESSIONAL INCOME.

Private fees (all descriptions).
Appointments.
National Insurance: (i) Capitation fees; (ii) drug fees; (iii) mileage.

A practitioner merely has to enter at the time of payment or receipt the amount expended or received in the appropriate column, at the same time entering the date and subsection number in the vacant space provided in the column. The sectional letters and the subsection numbers are omitted from the above summary of the schedule.

The new return and additional copies of the cash column interleaves will be supplied free to every practitioner who promises to send his return to the Medical Secretary when requested so to do. The form will be returned to the practitioner concerned as soon as the necessary particulars have been extracted. The information under each separate heading is essential, but any practitioner who is unable to state his non-professional expenses is asked to give what information he can under the other headings. Interleaves or, if desired, the complete book should be forwarded to the Medical Secretary, British Medical Association, 429, Strand, London, W.C.2.

Other practitioners who may wish to use the form to keep private particulars of their income and expenditure in a simple and easily accessible way can obtain it at a price of 1s., post free, and extra copies of the inside cash interleaves at 3d. each, from the Medical Secretary.

SANATORIUM BENEFIT IN SCOTLAND.

THE following communication has been sent to us by the Scottish Board of Health, 125, George Street, Edinburgh:

There appears to be some misunderstanding of the position of sanatorium benefit in Scotland. In England sanatorium benefit will not cease until May 1st to be included among the benefits conferred upon insured persons by Part I of the National Insurance Act, 1911; but in Scotland this termination has taken place, and as from January 1st, 1921, the Public Health Local Authorities have been required to make arrangements for the treatment of tuberculosis in insured persons. The issue of the National Health Insurance Termination of Sanatorium Benefit Regulations (Scotland), 1920, by the Scottish Board of Health completed the final transfer of this liability from Insurance Committees to local authorities.

Special arrangements have been made to ensure that there shall be no break in the continuity of treatment resulting from the transfer, and a special scheme under which treatment will be afforded by local authorities to ex-Service men suffering from tuberculosis has been devised. The local authorities are to receive, in respect of the treatment of insured persons suffering from tuberculosis, an Exchequer grant, which may be taken broadly as representing the amount that has been available to local Insurance Committees for institutional treatment; and in respect of the treatment of ex-Service men, the local authorities will obtain reimbursement of the entire cost of institutional treatment, and will also receive payment for the services of their tuberculosis officers.

CORRESPONDENCE.

Supply of Drugs in Rural Areas.

SIR,—I wish to call attention to the unreasonableness of Article 10 (2) of the Medical Benefit Regulations, 1920.

A certain rural practitioner does not wish to undertake any dispensing for insured persons, for there is a chemist residing practically opposite to him, and the latter has hitherto undertaken such work. An insured person, residing more than a mile away from the doctor, now claims to be supplied with drugs, etc., from the doctor, and the Insurance Committee has required that doctor to dispense such drugs, etc., much against the practitioner's wish.

Apparently the Insurance Committee cannot act otherwise under Article 10 (2). The doctor, of course, dispenses for his own private patients. It seems absurd that in this single isolated case, which inflicts no hardship upon the insured person, the doctor should be called upon to undertake a duty contrary to his usual practice.

In my opinion Article 10 (2) should be so amended that an Insurance Committee should have powers in refusing to allow an insured person this option of obtaining drugs from a practitioner, under special circumstances. The Article as it stands is entirely in favour of an insured person, and is unreasonable government.—I am, etc.,

SIDNEY CLARKE, M.D.,

Hon. Secretary, Hertfordshire Local Medical and Panel Committees.

St. Albans, Jan. 14th.

Insurance Medical Records.

SIR,—It is refreshing to read Dr. Bloxsome's letter in the SUPPLEMENT of January 15th after all the utter nonsense that has been inflicted upon us, both in the daily press and your previous issues, by men who, on the one hand, are using our profession as a pawn in a very apparent political game, and those who in the profession would like us to continue as little better than mountebanks.

I should think the majority of men would welcome the new system of keeping records of our cases as a definite step forward in a really scientific direction. Many of us have all through their careers kept records both of insured and private patients, and fully appreciate the fact that without these records they would have made little progress in their profession. The keeping of written records compels a man to read, because—unless he is a fool or a mountebank—he will not put in writing what he does not believe to be correct both in reasoning and fact. We have only to review the career of a man such as Sir James Mackenzie to realize the tremendous advantage to humanity which follows the keeping of records of cases, and, while it is given to few to possess the genius of such a man, and to be able to draw such far-reaching inferences as he has done, we can all gain tremendous benefits from the new system if we conscientiously carry it out.

The "professional secrecy" stunt is nothing but dust meant to delude the public, and an excuse for laziness. The records are not difficult to keep, if done daily; and even if they were they are worth it, and we are well paid for the work. Words fail me to realize the mentality of the man who puts up warning notices in his waiting-room about the keeping of records; he is certainly devoid of

any sense of humour, and my experience of the public, at least in these northern parts, is such that I know they are not to be taken in by such clap-trap.—I am, etc.,

Croft Mhairi, Tain, Jan. 16th.

ENEAS K. MACKENZIE.

SIR,—I have read with interest and some astonishment Dr. Bloxsome's letter under the above heading. It is ridiculous to say that the keeping of these records is very little extra work. With a moderately large panel I also have tested it. The amount of extra work, especially at this time of the year, is so much that I shall have to get clerical assistance.

I have thought the matter out, and think that the most expeditious way to get things done would be to have a clerk sitting in the waiting-room with the cabinets of envelopes; as the patient entered the room the clerk would find and hand him his envelope, which he would then bring in to me as his turn for admission arrived. Later, when surgery was over, the clerk would have to replace my pile of envelopes in their proper order in the cabinets. Whilst doing all this the whole idea of professional secrecy is done away with—it means that a third party possibly understands what is written, or otherwise that the doctor refrains from writing down essential details.

I am not interested in newspaper stunts; this is an innovation in our professional relations with patients, and I think a bad one. I quite agree with Dr. Fox's remarks about the production of record cards in law courts.

Dr. Bloxsome says we "are well paid for the work," and again I join issue with him. The bulk of practitioners doing panel work with whom I am acquainted agree that it is grievously underpaid.—I am, etc.,

Wednesfield, Jan. 10th. F. S. WILLIAMS, M.B., B.S. Lond.

SIR,—The suggestion made by Dr. Penrose in the SUPPLEMENT of January 15th is a most important one. In my own case the upper ends of the cards are already losing their elasticity to such an extent that I have had to add another box, and repack them more loosely. The stiffening of the upper portion means shortening the length of time it takes to hunt up a name. Perhaps a wire edge might be a still further improvement. I find the actual time taken for my panel, very slightly under 2,000, exceeds one hour daily, with the cards in their new state, in entering them up from one's day-book. There is no trouble in keeping a day-book. The time is taken up in entering from the day-book on to the cards, and the softer and more fingered these cards get the longer will be the time. I have tried several methods, and began keeping the cards from the moment they reached me, but I cannot reduce the time taken in entering up the record cards, working rapidly, to less than over one hour daily, so this softening of the cards is a very important matter.—I am, etc.,

Bristol, Jan. 15th.

E. J. BALL.

SIR,—The medical record scheme is decidedly a vexed question. The salient point is that it is unworkable. Even with a small panel it is at times impossible to make entries of all attendances, etc., and surely it is not necessary. Taken as a case-paper—giving essential points as to diagnoses and length of period of treatment—the record may be useful, both to the practitioner attending and to any successive medical attendant. That should be the use of the record, and it should be for medical use only. In the absence of records, I have made rough notes, alphabetically arranged, and I see no objection to the record if it is kept for a legitimate purpose of that nature; it will be beneficial both to doctor and patient. But to look out a card every time a patient is seen, with perhaps twenty or thirty people waiting for attendance, is practically impossible, and constitutes not a use but an abuse of the record system. This applies to a panel of hundreds, and with thousands the grievance is multiplied in corresponding ratio. It can only be done by employing clerical assistance, and then medical secrecy is altogether abolished.—I am, etc.,

Loughborough, Jan. 9th.

J. B. PIKE.

SIR,—Like a number of my friends, while complaining loudly at having so much extra work thrown on us by the Insurance Department of the Ministry of Health in the filling up of record envelopes and continuation cards, I am still anxious to fill them up as the Ministry would wish them done, but I find the directions are not explicit enough, and I am in doubt how to do them.

The directions say they are intended to last the whole of a man's working life, and at the same time every attendance is to be registered. If I were to follow this out with some of my patients the record envelope would be filled up and would also be filled with continuation cards in less than twelve months. It would help me and

no doubt a number of others if we might have a fac-simile of the back of an envelope for a supposed ease of pneumonia filled up and published in the next issue of your valuable JOURNAL. We should then see how it was intended we should fill them up.—I am, etc.,

Rotherham, Jan. 15th.

FREDK. J. BURMAN.

"J. S. D." writes: I have read with interest the various letters in the SUPPLEMENT regarding the new medical records, and it appears to me that the profession is being saddled needlessly with a great deal of cumbersome clerical work of very doubtful use, both from a statistical standpoint and the maintenance of professional secrecy. To my mind it seems belated and ludicrous to attempt to preserve professional secrecy by means of sealed windowed envelopes when one thinks of the immense number of incapacity certificates, issued daily by practitioners to insured persons, openly stating their names, and the diseases from which they are suffering; as every doctor knows, these are usually sent to the secretary in the case of small societies, or to the branch office of large societies, where they are probably open to the inspection of every member of the staff. The new arrangement looks very much like a case of "locking the stable door after the horse has bolted."

Naval and Military Appointments.

ROYAL NAVAL MEDICAL SERVICE.

THE following notifications are announced by the Admiralty: Surgeon Commanders R. B. Scribner to the *Victory* for hospital ship *Berberice*, G. S. Davidge to the *Crescent*, additional for duty at Leith and Granton, G. T. Verry to the *President*, additional for three months' hospital course, A. Woolcombe to the *Colossus*, T. E. Blunt to Haslar Hospital, Surgeon Lieut. Commanders H. E. R. Stephens, O.B.E., to the *Cleopatra* (temporary), L. R. Warburton, O.B.E., to R.N. Hospital, Catham, A. H. Joy to the *Bee*. Surgeon Lieutenant A. F. Grimby to the *Cyclamen*.

Surgeon Lieutenant G. L. Ritchie has been promoted to the rank of Surgeon Lieutenant Commander.

ARMY MEDICAL SERVICE.

Colonel E. M. Morphew, C.M.G., D.S.O., is placed on half pay. Colonel C. K. Morgan, C.B., C.M.G., retires on retired pay.

ROYAL ARMY MEDICAL CORPS.

Major F. T. Dowling relinquishes the acting rank of Lieutenant-Colonel.

Major J. Startin, M.C., is placed on the half-pay list on account of ill health.

The following retire on retired pay: Lieut.-Colonel A. F. Weston, Major F. A. Stephens, D.S.O. (November 14th, 1920, substituted for notification in the *London Gazette* of November 12th, 1920).

Captain D. T. M. Large to be temporary Major whilst specially employed.

Captain L. F. K. Way, D.S.O., retires, receiving a gratuity.

The following officers relinquish their commissions: Temporary Majors and retain the rank of Major: H. W. Wooley, J. M. Mathieson (on ceasing to be employed at the Wharfedale War Hospital). Temporary Captains and retain the rank of Captain: P. MacD. Little, M.C., T. Sheehan, H. Morell, L. Fraser, H. Bell, G. Cock, R. W. Harper, E. C. Lindsey, C. F. Maciachlan, M.C., O. Marshall, R. C. Phelps. Temporary Lieutenants and retain the rank of Lieutenant: J. S. F. J. Kerr, E. P. O'Dowd, J. A. A. P. Scott.

ROYAL AIR FORCE.

MEDICAL BRANCH.

Captain J. Fanning is transferred to the unemployed list.

Captain A. E. McCulloch relinquishes his temporary R.A.F. commission (January 9th, 1919, substituted for notification in the *London Gazette* of January 21st, 1919).

GENERAL RESERVE OF OFFICERS.

ROYAL ARMY MEDICAL CORPS.

A. L. Aymer, late Captain R.A.M.C. to be Major, April 24th, 1920, and the notifications in the *London Gazette* of April 28th and June 4th, 1920, are cancelled.

DIARY OF SOCIETIES AND LECTURES.

HARVEIAN SOCIETY OF LONDON, Paddington Town Hall, W.—Thursday, 8.30 p.m., adjourned debate on the Future of the Poor Law Infirmary.

LONDON DERMATOLOGICAL SOCIETY, 49, Leicester Square, W.C.—Thursday, 6 p.m., Chesterton Lecture by Dr. W. K. Sibley: Acne.

MEDICAL SOCIETY OF LONDON, 11, Chandos Street, W.1.—Monday, 8.30 p.m., Dr. Anthony Feiling: Multiple Neuritis. Dr. F. G. Crookshank: Handprints in Mongolian and other Imbeciles.

ROYAL SOCIETY OF MEDICINE.—*Section of Odontology*: Monday, 8 p.m., Sir Frank Colyer: Old Dental Instruments. *Section of Medicine*: Tuesday, 5.30 p.m., Dr. P. J. Cammidge: Classification of Diabetes Mellitus. Dr. E. P. Poulton: Treatment of Peptic Ulcer by Gastric and Gastro-duodenal Tubes (to be preceded, at 5 p.m., by a demonstration of Cases). *Section of Bacteriology and Climatology*: Thursday, 5.30 p.m., Presidential Address, Dr. G. L. Pardington: Advancing Years and Palneotherapy. Members of Section, with guests, will dine at the Welbeck Palace Hotel, Welbeck Street, W., at 7 p.m. Those intending to be present are requested to notify Dr. C. F. Sonntag, 80A, Belsize Park Gardens, N.W.3, by January 26th. *Section of Urology*: Thursday, 3.30 p.m., at King's College Hospital, Operations by Mr. Thomson Walker: 8.30 p.m., at 1, Wimpole Street, W., Mr. Thomson Walker: Obstruction after Suprapubic Prostatectomy. *Section of Study of Disease in Children*: Friday, 4.30 p.m., Cases. *Section of Epidemiology and State Medicine*: Friday, 8.30 p.m., Dr. A. S. M. MacGregor: Current Small-pox in Glasgow.

POST-GRADUATE COURSES AND LECTURES.

GLASGOW POST-GRADUATE MEDICAL ASSOCIATION, Royal Maternity and Women's Hospital.—Wednesday, 4.15 p.m., Dr. J. H. Martin: Obstetrical Cases.

HOSPITAL FOR SICK CHILDREN, Great Ormond Street, W.C.1.—Thursday, 4 p.m., Mr. Barrington Ward: Hare lip and Left Palate.

MANCHESTER: ANCOATS HOSPITAL.—Thursday, 4.30 p.m., Dr. Reushaw: Specific Bactericidal Substances.

MANCHESTER ROYAL INFIRMARY.—Tuesday, 4.30 p.m., Dr. J. M. Brockbank: Pernicious Anaemia.

MANCHESTER: ST. MARY'S HOSPITALS (Whitworth Street West Branch).—Friday, 4.30 p.m., Dr. Clifford: Differential Diagnosis of Abdominal Swellings.

NATIONAL HOSPITAL FOR DISEASES OF THE HEART, Westmoreland Street, W.1.—Monday, 5.30 p.m., Dr. J. Parkinson: Tachycardia.

NATIONAL HOSPITAL FOR THE PARALYSED AND EPILEPTIC, Queen Square, W.C.1.—Daily (except Wednesday and Saturday), 2 p.m., Out-patient Clinics. Lectures, 3.30 p.m., Monday and Friday, Dr. Greenfield: Cerebro-spinal Fluid. Demonstrations of Cases, 3.30 p.m.; Tuesday, Dr. Russell; Thursday, Dr. Taylor.

NORTH-EAST LONDON POST-GRADUATE COLLEGE, Prince of Wales's General Hospital, Tottenham, N.—Daily, In- and Out-patient Clinics, etc., 2.30 p.m., Operations. Lectures, 3 p.m.—Wednesday, Dr. Whiting: Cardiac Arrhythmia. Thursday, Dr. Hadfield: Spinal Anaesthesia. Friday, Dr. Sundell: Thoracic Tuberculosis in Children. Full particulars can be obtained from the Dean.

WEST LONDON POST-GRADUATE COLLEGE, Hammersmith, W.—Daily, 10 a.m., Ward Visits; 2 p.m., In- and Out-patient Clinics and Operations. Lectures, 5 p.m.—Monday, Mr. Harman: Chronic Indigestion and Visual Acuity. Tuesday, Dr. Burnford: Investigation of Digestive Tract. Wednesday, Dr. Simson: Obstetric Emergencies. Thursday, Mr. Pinch: Radium Therapy. Friday, Mr. Baldwin: Appendicitis.

British Medical Association.

OFFICES AND LIBRARY, 429, STRAND, LONDON, W.C.2.

Reference and Lending Library.

THE READING ROOM, in which books of reference, periodicals, and standard works can be consulted, is open to members from 10 a.m. to 6.30 p.m., Saturdays 10 to 2.

LENDING LIBRARY: Members are entitled to borrow books, including current medical works; they will be forwarded, if desired, on application to the Librarian, accompanied by 1s. for each volume for postage and packing.

Departments.

SUBSCRIPTIONS AND ADVERTISEMENTS (Financial Secretary and Business Manager, Telegrams: Articulat, Westrand, London), MEDICAL SECRETARY (Telegrams: Medisecra, Westrand, London), EDITOR, *British Medical Journal* (Telegrams: Aftiology, Westrand, London).

Telephone number for all Departments: Gerrard 2630 (3 lines).

SCOTTISH MEDICAL SECRETARY: 6, Rutland Square, Edinburgh. (Telegrams: Associate, Edinburgh. Tel.: 4361 Central.)

IRISH MEDICAL SECRETARY: 16, South Frederick Street, Dublin. (Telegrams: Ecillus, Dublin. Tel.: 4737 Dublin.)

Diary of the Association.

JANUARY.

- 21 Fri. London: Ministry of Health Committee, 2.30 p.m.
25 Tues. London: Scrutiny Subcommittee, 2 p.m.
London: Superannuation Subcommittee, 2 p.m.
London: Public Health Committee, 3 p.m.
Harrow Division, Gayton Rooms, Harrow, 9 p.m.
25 Wed. London: Medico-Political Committee, 11.30 a.m.
London: Journal Committee, 2.30 p.m.
27 Thurs. London: Insurance Aets Committee, 2.30 p.m.
City Division, Metropolitan Hospital, 9 p.m.
28 Fri. London: Central Ethical Committee, 2 p.m.

FEBRUARY.

- 1 Tues. London: Grants Subcommittee, 9.30 a.m.
London: Propaganda Subcommittee, 10 a.m.
London: Organization Committee, 11 a.m.
2 Wed. London: Finance Committee, 2.30 p.m.
4 Fri. London: Medico-Sociological Committee, 2.30 p.m.
London: Naval and Military Committee, 2.30 p.m.
16 Wed. London: Council, 10 a.m.

APPOINTMENTS.

ADAMSON, James W. W., M.D. Durh., a Senior Neurologist at Ashhurst Neurological Hospital (Ministry of Pensions), Littlemore, Oxford.

EAST, A. G., M.B., D.O. Oxon., D.O.M.S., Honorary Ophthalmic Surgeon to the Royal Cornwall Infirmary.

VALENTINE, J. A., B.A., M.D. Dubl., D.T.M. and H. Camb., Surgeon Portsmouth and Southern Counties Eye and Ear Hospital.

BIRTHS, MARRIAGES, AND DEATHS.

The charge for inserting announcements of Births, Marriages, and Deaths is 9s., which sum should be forwarded with the notice not later than the first post on Tuesday morning in order to ensure insertion in the current issue.

BIRTH.

MILLER.—On January 8th, 'at 32, Abercorn Place, N.W.8, to Dorothy, wife of Dr. Reginald Miller, F.R.C.P. (of 110, Harley Street, W.1)—a daughter.

DEATH.

MACKENZIE.—On the 14th January, at The Croft, Dorking, Helen, widow of Sir Stephen Mackenzie, M.D., of 18, Cavendish Square, W.

SUPPLEMENT

TO THE

BRITISH MEDICAL JOURNAL.

LONDON: SATURDAY, JANUARY 29TH, 1921.

CONTENTS.

	PAGE
BRITISH MEDICAL ASSOCIATION.	
CURRENT NOTES:	
CONFERENCE OF REPRESENTATIVES OF VOLUNTARY HOSPITAL STAFFS IN SCOTLAND...	25
PROPOSED CENTRAL PROFESSIONAL COMMITTEE	25
HOME OFFICE REGULATIONS AS TO DANGEROUS DRUGS	25
FEES FOR TREATMENT OF SCHOOL CHILDREN IN SCOTLAND	25
POOR LAW HOSPITALS AND CIVIL NEEDS	25
MEETINGS OF BRANCHES AND DIVISIONS	25
ASSOCIATION NOTICES	26

	PAGE
INSURANCE CORRESPONDENCE:	
RECORD CARDS	27
MEDICAL BENEFIT	27
CENTRAL INSURANCE DEFECT FUND	28
DIARY OF SOCIETIES AND LECTURES	28
ASSOCIATION INTELLIGENCE	28
DIARY OF THE ASSOCIATION	28
APPOINTMENTS	28
BIRTHS, MARRIAGES, AND DEATHS	28

British Medical Association.

CURRENT NOTES.

Conference of Representatives of Voluntary Hospital Staffs in Scotland

The Hospitals Subcommittee of the Scottish Committee has convened a conference of staffs of voluntary hospitals to be held in the offices at 6, Rutland Square, Edinburgh, on Saturday, February 5th, at 2.30 p.m., to consider the present financial position of voluntary hospitals.

Proposed Central Professional Committee.

It will be remembered that when, on November 1st, 1920, a deputation of the British Medical Association waited upon the Minister of Health in regard to certain clauses in his Miscellaneous Provisions Bill and the Municipal Hospital at Bradford, he declared that he would not consult half a dozen different bodies each claiming to represent the profession, and invited the Association to take action to provide some body which he would be justified in considering representative of all sections. Dr. Addison followed this up by a letter, dated November 26th, to the Chairman of Council, in which he said:

"The difficulty is how to secure the appointment of a body which will be recognized not only by practitioners of all classes but by the various existing organizations as expressing the views of all sections of the profession. It is, of course, not for me to make any suggestions as to how such a body might be, or ought to be, constituted. But I am satisfied that it will be impossible to secure the constitution of a representative body without the good offices of the British Medical Association in bringing them together, and if your Council have not already done so, I would suggest that you should now initiate action to secure the appointment of a body whose credentials will be incontestable."

Since that time the Council has given very careful consideration to the matter, the details of which will probably be reported later; but it will interest members of the profession to know now that the Council at its last meeting resolved to invite those bodies with which the British Medical Association has been accustomed to work to assist it in establishing a joint representative committee, and it has asked the Society of Medical Officers of Health, the Medical Women's Federation, the Poor Law Medical Officers' Association of England and Wales, the Medico-Psychological Association, and the Association of Certifying Factory Surgeons if they are willing to co-operate with the Association in forming a body which could be suggested to the Minister of Health as providing him with the representative medical body which he has asked for. This is a preliminary step, and it must be understood that the above list is not necessarily final or complete. It is particularly hoped that the co-operation of the Royal Colleges may be secured when the project is a little more mature, and it is proposed that

such a joint representative medical committee, if established, should be empowered to confer, before making representations to the Ministry of Health on behalf of the profession on any matter, with any other medical society not represented on the committee.

Home Office Regulations as to Dangerous Drugs.

As stated in the JOURNAL of January 15th, page 96, the Home Office has issued draft Regulations of a very drastic nature in regard to the prescribing and dispensing of medicinal opium, morphine, cocaine, eegonine, and diamorphine. These regulations are issued under the Dangerous Drugs Act, and forty days must elapse between the issue of the draft regulations and their becoming operative. The Medico-Political Committee has already made a protest to the Home Office on general grounds, and is considering detailed representations with a view to modification of the regulations. These regulations, which will affect the daily life of every practising doctor, have been issued without any attempt to consult the British Medical Association as representing the organized profession. It is understood that the Pharmaceutical Society also was not consulted and is making strong representations as to the impracticability of the regulations.

Fees for Treatment of School Children in Scotland.

Attention was called to this matter in "Current Notes" on December 4th, 1920, and the situation which had arisen in Renfrewshire was explained. The local education authority had offered a fee of 15s. an hour for clinic work, and the practitioners in Port Glasgow had refused this and asked the support of the British Medical Association. The matter was taken up by the Division Secretary and the Scottish Medical Secretary, with the result that an offer of £1 1s. an hour has now been made.

Poor Law Hospitals and Civil Needs.

The Hospitals Committee has given very careful consideration to the question of the utilization of Poor Law hospitals for civil needs, and has passed the following resolutions, which will be submitted to the Council at its meeting on February 15th:

1. That in those infirmaries where there is spare accommodation and when the beds of the Poor Law patients have been met, it would be desirable that certain beds should be set aside for private patients paying a fee to be settled by the guardians, and that where a general practitioner wishes to continue to treat them patients of his own, he should be allowed to do so under the general administrative supervision of the medical superintendent, and that any of these patients should be allowed to call in a consultant from outside, the patient bearing the cost thereof.
2. That for "paying" patients admitted to infirmaries there should be an inclusive charge—to cover the cost of medical supervision, maintenance, nursing, food, and medicines within the ordinary tariff and pharmacopoeia

of the infirmary, the patient paying his medical attendant independently.

3. That any extra nursing and any food or medicine ordered over and above those allowed under the ordinary tariff and pharmacopoeia of the infirmaries should be charged as extras to the patient.
4. That all medical attendance by private practitioners on "paying" patients in infirmaries should be under the supervision of the medical superintendent of the infirmary.
5. That infirmaries, so far as practicable, should be utilized for medical education.

These resolutions were submitted by Dr. E. W. G. Masterman to a meeting of the Infirmary Medical Superintendents' Society, who passed the following resolutions in connexion therewith:

- (1) That when in any infirmary there are beds to spare, after the needs of the poor in the district are met, it is desirable that accommodation should be provided for private patients, who would pay a fixed sum covering their expenses.
- (2) That if, and only if, separate wards can be provided for their accommodation, such patients should, if they desire, continue under the treatment of their own medical attendants while in the infirmary, subject to the general administrative supervision of the medical superintendent, and also, if they so desire, call in other consultants' advice at their own expense.

Meetings of Branches and Divisions.

METROPOLITAN COUNTIES BRANCH: HARROW DIVISION.

THE Division recently held three meetings to discuss the new record card for insured patients. These were held on January 4th, 14th, and 21st.

At the first meeting two resolutions were passed, after prolonged discussion. The first called attention to the objections to these records, outlined under five heads. The second had reference to the attitude of the Council in the matter, which was severely criticized, and to the correspondence of the Medical Secretary in the *Times*. The latter also was commented on very adversely.

On January 14th, as a result of these resolutions, the Division met again, to hear Dr. R. A. Bolam, Dr. Brackenbury, and Dr. Cox, who attended to put the case for the Association before the Division. The speeches of these visitors were of great assistance, and much information about the records and the press controversy regarding them was made available to the members. This meeting was adjourned to January 21st, as much remained for discussion, but before the adjournment a vote of confidence in the Medical Secretary was carried unanimously.

On January 21st another crowded meeting assembled, and many interesting speeches were made. A noticeable feature of several of these were the strong appeals for greater membership of the Association and for unanimity among the profession generally. As a result the following voting took place on these motions:

1. That the resolution embodying the Division's objections to the records be rescinded.
For, 8. Against, 7.

Many members refrained from voting, and it was agreed that the records should be discussed again in six months' time—after a trial of them had been made—the result to be reported to the Insurance Acts Committee.

2. That the resolution criticizing the action of the British Medical Association Council be rescinded.
For, 9. Against, 5.

Again a number of members did not vote.

The Division expressed its thanks to Drs. Bolam, Brackenbury, and Cox for having attended the meeting on January 14th.

METROPOLITAN COUNTIES BRANCH: WEST HERTFORDSHIRE DIVISION.

AT a meeting of the Watford Ward of the West Hertfordshire Division, held on January 7th, the following resolution was unanimously adopted:

That this meeting of panel practitioners protests—

1. That the new medical record cards were not submitted, previous to their issue, either to the Divisions of the British Medical Association or to the Panel Committees for an opinion from those who had to use them as to their feasibility and usefulness.
2. That this meeting is of opinion (a) that it is a waste of practitioners' time to verify and supply particulars of a clerical nature, and that generally the time required for this work will be more than can be given by panel practitioners, except to the prejudice of their real work; (b) that in the winter and times of stress it will be impossible to keep accurately the records as at present required, and therefore their value for statistical purposes will be destroyed; (c) that the record card should be kept by the insured person, the necessary particulars being entered by the doctor when giving attendance; (d) that panel practitioners should only be asked to supply the information required under Clinical Notes and Diagnosis.

LANCASHIRE AND CHESHIRE BRANCH: ST. HELENS DIVISION.

Visit of the Medical Secretary.

A MEETING of this Division was held on January 21st in the Board Room of the Providence Hospital, a large attendance of members and others being present to hear Dr. Cox, who was ably supported by Dr. Garstang, Chairman of Representative Meetings. Both were accorded a hearty welcome.

Dr. Cox gave a practical address on the history and working of the Association, pointing out that the interest of every class of practitioner was catered for by the Association. He showed the advantages to all classes—consultants, general practitioners, those in the public health and other institutional services, and to the men serving in the navy and army. The audience was much interested and the address not unprofitable; the Divisional Secretary being later in a position to report the acquisition of four new members, and the reclamation of other two former members who had resigned.

An animated discussion followed, during which many questions were asked and criticisms offered, to which Dr. Cox replied.

Dr. GARSTANG also spoke and gave a lucid and interesting account of the administrative machinery of the British Medical Association and its committees. He impressed upon his hearers how greatly the Association was dependent upon the Branches, Divisions, and especially the members, for the proper and efficient working of that body, and how deeply their individual and collective responsibility was concerned. The meeting was unanimous in its expression of appreciation of the work of the Association, and the visit of the Medical Secretary has aroused in the Division a keener interest in the British Medical Association and its work.

SOUTHERN BRANCH: PORTSMOUTH DIVISION.

A WELL attended meeting was held on January 11th at Portsmouth, to which all medical practitioners resident in Portsmouth were invited, to discuss the attitude of the profession to the new panel record cards. After considerable discussion the following resolution was, on the motion of Dr. J. G. BLACKMAN, seconded by Dr. A. V. MAYBURY, jun., carried unanimously:

This meeting is of opinion that the present record cards are for the most part valueless, that they occupy valuable time which would be better devoted to the treatment of the sick, and moreover they violate the confidence which should exist between doctor and patient. That this resolution be sent to the Ministry of Health, local members of Parliament, and the press, and to the Friendly Societies Council.

The following motion, proposed by Dr. MCASKIE and seconded by Dr. NEWTON, was, after discussion, carried by a large majority:

That the record cards be kept (according to regulation), and only handed over under protest until secrecy is assured.

The question of whether the record cards would be available for use in legal cases was also raised.

On the motion of Dr. SHEAHAN, seconded by Dr. BLACKMAN, it was unanimously resolved:

That the Insurance Acts Committee in not offering the most strenuous opposition to the new system of record keeping has forfeited the confidence of practitioners working under the National Health Insurance Acts.

Association Notices.

MEETING OF COUNCIL.

THE next meeting of Council will be held on Wednesday, February 16th, in the Council Room, 429, Strand, London, W.C.2, at 10 a.m.

CHANGE OF AREAS.

Areas of Edinburgh and Leith, and Lothians, Divisions.

NOTICE is hereby given by the Council to all concerned that, as the result of a proposal to that effect by the Edinburgh and Leith Division, the Council has decided that as from January 29th, 1921, the following places (having been merged by the Edinburgh Boundaries Extension Act, 1920, in the City of Edinburgh)—namely, Colinton, Corstorphine, Cramond, Juniper Green, and Liberton—be transferred from the area of the Lothians Division to that of the Edinburgh and Leith Division.

BRANCH AND DIVISION MEETINGS TO BE HELD.

METROPOLITAN COUNTIES BRANCH: CAMBERWELL DIVISION.—A meeting of the Camberwell Division will be held on Wednesday, March 2nd, when Dr. Hector Cameron, of Guy's Hospital, will give an address on Children.

METROPOLITAN COUNTIES BRANCH: EAST HERTFORDSHIRE DIVISION.—A meeting of this Division will be held at the Hertford County Hospital on Wednesday, February 2nd, at 2.30 p.m. A lecture will be delivered by Dr. John Freeman (London) on asthma from the immunological point of view, at 3 p.m. Each member is asked to invite one non-member.

INSURANCE. CORRESPONDENCE.

Record Cards.

SIR,—The flutter that the record cards have caused is somewhat amusing, but reveals a state of mind in our profession which is not logical.

As to the vast proportion of the insured, I do not think they can grumble at the details of their illnesses being recorded or becoming public property.

As to the profession, it is a pity that those of us who foresaw the probable developments were not listened to. Personally I have always hated the Act.

I must not omit to mention that the record cards have proved valuable to me in one particular. As I see each patient I refer to my batch of cards, and I am surprised to find what a number of patients I have been treating for whom no record card has been provided.

Plymouth, Jan. 22nd.

S. NOY SCOTT.

SIR,—A large medical fund that has several thousand insured members, attended by several medical men, has adopted a method of note-taking that might with advantage be used by private practitioners.

Bradford-on-Avon, Jan. 22nd.

CHAS. E. S. FLEMMING.

The following is a reproduction, reduced in size, of the leaf forwarded by Dr. Flemming:

Table with columns: Name, Address, Date, V, A, C, Clinical Notes, Diagnosis. Includes a signature line for the Doctor.

SIR,—In common with Dr. Mackenzie, I was very glad to read Dr. Bloxsome's letter in the SUPPLEMENT of January 15th.

With a panel of 900 I find the keeping of the records entails very little extra work. Undoubtedly during an epi-

demic the clerical work would assume greater proportions, but epidemics do not last for ever.

The "professional secrecy" question is, I think, much over-rated. Are we not, as a profession, making ourselves ridiculous over this subject?—I am, etc.,

J. PAULLY, M.B., B.S.Lond.

Pulham Market, Norfolk, Jan. 23rd.

SIR,—The medical record scheme is one that is admittedly not desired by the bulk of the panel practitioners or their insured patients.

I suggest that if we are to get this fresh inquisition rescinded we must once and for all pull together and endeavour to get every Panel Committee in the country to put a spoke in the wheel against this Ministerial tyranny.

Liskeard, Cornwall, Jan. 24th.

BRIAN B. METCALFE.

The Annual Conference of Local Medical and Panel Committees held on October 21st, 1920, after discussion passed a resolution to the following effect: While accepting the obligation to keep records in some form...

Medical Benefit.

SIR,—Enclosed is a copy of a letter I am sending to the Minister of Health. The subjects, to my mind, are so important that I think they deserve publication.

A. R. EATES, M.D.

To the Minister of Health.

SIR,—Re doctors' "lists," capitation fees, medical benefit, I beg to make a statement, and to ask if you will be so good as to order an inquiry to be made upon the cases I now bring to your notice.

I am on the panel for the County of London, and am supposed to have a "list" of between 1,400 and 1,500 insured persons; record cards supplied, so far, are woefully incomplete in number.

1. Mr. A., who was taken off, "ceased insurance," as from June 30th, 1919. Since that date A. applied for, and was really in need of, medical aid, which I could not give him as an insured person.

2. Miss B. removed, "ceased" June 30th, 1919; "reinstated" July 10th, 1919. Postcard and letter to Insurance Committee re date of reinstatement secured correction of date to July 1st, 1919.

3. Mr. C. Removed, "ceased" September 30th, 1920, whilst under treatment. After his removal from my list I charged a fee, in accordance with regulations, giving an official receipt.

4. Miss D. Removed, "ceased" September 30th, 1920. Has come up since for treatment, maintains that she has been wrongly deprived of benefit, declines to pay fees, and has been referred by me to the Insurance Committee.

5. Miss E. "Title to benefit not established." Removed September 30th, 1920. Maintains she is in full benefit. Cannot pay fees. Referred to Insurance Committee.

6. Miss F. "Out of benefit" March, 1919. Removed. Has since been attended by me—not charged fees. Maintains she is in full benefit.

to benefit. Am I to charge her fees, and so risk depriving her of treatment of which she is really in need?

7. Mrs. G. Removed, "ceased", December 31st, 1919. Recently came up for treatment as an insured person. Referred to Insurance Committee. Has since been "reinstated," and four quarters' capitation fees have been credited to me. No explanation of this blunder (?). May I here point out, Sir, that had this insured person not come up for treatment when she did, or had my own bookkeeping been as faulty as that of the Government, I should have lost one year's capitation fee? The same observation applies to the other cases mentioned, but who knows to how many others who have not come up for treatment it is applicable?

The last case I would bring under your notice is of a different nature:

8. Mr. E. This man applied to be placed upon my list in March, 1920. He brought his own card and that of his wife. These were signed by me and sent, together with some half a dozen others, to the Insurance Committee on March 24th, 1920. Some two months later the man applied to me for his card—his wife's had reached her. Referred to the Insurance Committee, who, after several applications by the insured person, furnished him with his medical card, placing the man on my list as from July 30th, 1920, thereby depriving me of two quarters' capitation fees.

Many representations by me have failed to get this matter adjusted by the Insurance Committee. Now, Sir, upon what grounds do the Committee justify their action in this case? I sent up the card in March, and it is for the Committee to prove that it was received only in July. And I mean to say that I see no reason why I should suffer for the errors of the Committee.

In conclusion, Sir, I would say that if doctors are prosecuted for alleged frauds upon Insurance Committees and approved societies, I now confidently expect to hear that by your action in the cases I place before you the Public Prosecutor will get busy.—I am, Sir, your humble fellow-servant of the State.

London, W., Jan. 13th.

A. R. EATES, M.B.

Central Insurance Defence Fund.

SIR,—As one who has applied for the return of the balance due to me, might I suggest to my fellow conspirators who are doing the same that the amounts they receive should be handed over to the Royal Medical Benevolent Fund to augment the *endowment*? If half the men ask for a refunding of their money and put it to such a use the endowment of this fine institution would benefit to the extent of about £6,000, and the donors would not feel that their pockets were any the lighter.—I am, etc.,

Bridport, Jan. 20th.

C. EDWARDS, M.D.

"AN OLD KINGSLEYITE" writes: The Secretary has sent a letter to the subscribers to the above fund, saying that it is to be wound up. In brief the chief points are as follows: About £30,000 subscribed; expended, £18,000, for compensation, etc.; balance £12,000. The subscribers are entitled to receive the balance, which may be 12s. 6d. in the £. The Insurance Acts Committee with the Council of the British Medical Association, after careful consideration decided that the balance be transferred to a new trust called the National Insurance Defence Trust. The objects are set forth and are worthy of support. Already I have consulted some of the subscribers, and it is suggested that one-half should be devoted to the Defence Trust and the other divided equally between the Royal Medical Benevolent Fund and Epsom College. Both have special claims on the medical profession; both are in need of special financial help. The British Medical Association for many years, through the active assistance of our late general manager, Mr. Elliston, raised large sums. Some of the subscribers have died; others have removed, and their addresses are lost. Few, if any, would wish to have their subscriptions returned if they knew that these very worthy charities would receive their share.

DIARY OF SOCIETIES AND LECTURES.

LONDON DERMATOLOGICAL SOCIETY, 49, Leicester Square, W.C.—Thurs., 6 p.m., Chesterfield Lecture by Dr. W. Griffith: Parasitic Diseases of the Skin.

MIDDLESEX HOSPITAL MEDICAL SCHOOL.—Emeritus Lectures: Surgeon Rear Admiral Bassett-Smith, Tues., 3 p.m., Mediterranean Fever; Thurs., 3 p.m., Malaria.

ROYAL SOCIETY OF MEDICINE.—Occasional Lecture, Thurs., 5.30 p.m., Prof. F. Hobday: Diseases of Animals Contagious to Man. Section of Surgery: Subsection of Orthopaedics: Tues., 5 p.m., Cases; 6 p.m., Dr. G. Murray Leick: Reactions and Electrical Treatment of Intrinsic Muscles of Foot. Section of Pathology: Pathological Laboratory, University College Hospital Medical School, Tues., 8.30 p.m., Dr. Penfield: Golgi Apparatus in Nerve Cells; Mr. Barrington: Fungus Parasite in Kidney of Rabbit; Dr. Walshe: Encephalitis Lethargica; Dr. Lewis: Demonstrations; Mr. T. W. P. Lawrence: Specimen; Prof. Boycott: Hypertrophy of Haemoglobin. Section of Surgery: Wed., 5 p.m., Cases; 5.30 p.m., Mr. G. L. Edington: Meckel's Diverticulum as a Cause of Intestinal Obstruction. Section of Obstetrics and Gynaecology: Thurs., 8 p.m., Mr. F. C. Pybus: Tuberculous Peritubal Cyst; Dr. T. W. Eden and Mr. F. L. Provis: X-ray Treatment of Fibroids and Chronic Metritis. Section of Laryngology: Fri., 4 p.m., Epidiascope Demonstrations and Cases. Section of Anaesthetics: Fri., 8.30 p.m., Dr. Rowbotham and Dr. I. Magill: Anaesthesia in Plastic Surgery.

POST-GRADUATE COURSES AND LECTURES.

GLASGOW POST-GRADUATE MEDICAL ASSOCIATION, Victoria Infirmary, —Wed., 4.15 p.m., Mr. Parry: Surgical Cases.

HOSPITAL FOR SICK CHILDREN, Great Ormond Street, W.C.1.—Thurs., 4 p.m., Dr. W. J. Pearson: The Premature Child.

LONDON LOCK HOSPITALS.—Clinical instruction daily. Lectures: (Male Hospital, Dean Street) Mon., 5 p.m., Mr. Gibbs: Complications of Prostatic Urethritis; Tues., 2.30 p.m., Mr. McDonagh: Nervous Syphilis; 5 p.m., Mr. Juler: Venereal Diseases of the Eye; Wed., 4.30 p.m., Mr. Joly: Acute Gonorrhoea in the Male; Fri., 4 p.m., Mr. Abraham: Gonorrhoeal Rheumatism.

MANCHESTER BABIES' HOSPITAL.—Sat., 3.30 p.m., Dr. Chisholm: Treatment of the Premature Child.

MANCHESTER ROYAL INFIRMARY.—Tues., 4.30 p.m., Mr. C. Roberts: Hernia.

MANCHESTER: ST. MARY'S HOSPITALS (Whitworth Street West Branch)—Fri., 4.30 p.m., Dr. Fothergill: Physical Signs in Abdomino-pelvic Surgery.

NATIONAL HOSPITAL FOR DISEASES OF THE HEART, Westmoreland Street, W.1.—Mon., 5.30 p.m., Dr. Goodall: Cardio-analysis.

NATIONAL HOSPITAL FOR THE PARALYSED AND EPILEPTIC, Queen Square, W.C.1.—Daily (except Wed. and Sat.), 2 p.m., Out-patient Clinics. Lectures—3.30 p.m., Mon., Dr. Greenfield: Cerebro-spinal Fluid; Tues., Dr. Collier: Headache; Thurs., Dr. Buzzard: Neuritic Affections. Demonstration of cases, Fri., 3.30 p.m.

NORTH-EAST LONDON POST-GRADUATE COLLEGE, Prince of Wales's General Hospital, Tottenham, N.—Daily, 2 p.m., In- and Out-patient Clinics, Operations, etc. Lecture-demonstrations.—Mon., 4.30 p.m., Mr. Tanner: Surgical Cases; Tues., 3 p.m., Mr. Hayton: Vincent's Angina; Wed., 4.30 p.m., Dr. Alexander: Thyroid Insufficiency; Thurs., 3 p.m., Mr. Carson: Surgical Cases; Fri., 3 p.m., Mr. Gillespie: Cases of Surgical Interest.

SALFORD ROYAL HOSPITAL.—Thurs., 4.30 p.m., Mr. Jefferson: Gall Stones.

WEST LONDON POST-GRADUATE COLLEGE, Hammersmith, W.—Daily, 10 a.m., Ward Visits; 2 p.m., In- and Out-patient Clinics and Operations. Lectures—5 p.m., Mon., Dr. Saunders: Digestive Disturbances of Adults; Tues., Dr. Burnford: Morbid Anatomy of Digestive Tract; Wed., Mr. Armour: Abdominal Tumours; Thurs., Dr. Strangeways: Rheumatoid Arthritis; Fri., Mr. Baldwin: Appendicitis.

British Medical Association.

OFFICES AND LIBRARY, 439, STRAND, LONDON, W.C.2.

Reference and Lending Library.

THE READING ROOM, in which books of reference, periodicals, and standard works can be consulted, is open to members from 10 a.m. to 6.30 p.m., Saturdays 10 to 2.

LENDING LIBRARY: Members are entitled to borrow books, including current medical works; they will be forwarded, if desired, on application to the Librarian, accompanied by 1s. for each volume for postage and packing.

Departments.

SUBSCRIPTIONS AND ADVERTISEMENTS (Financial Secretary and Business Manager. Telegrams: Articulate, Westrand, London). MEDICAL SECRETARY (Telegrams: Medisecra, Westrand, London). EDITOR, *British Medical Journal* (Telegrams: Aitiology, Westrand, London).

Telephone number for all Departments: Gerrard 2630 (3 lines).

SCOTTISH MEDICAL SECRETARY: 6, Rutland Square, Edinburgh. (Telegrams: Associate, Edinburgh. Tel.: 4361 Central.)

IRISH MEDICAL SECRETARY: 16, South Frederick Street, Dublin. (Telegrams: Bacillus, Dublin. Tel.: 4737 Dublin.)

Diary of the Association.

JANUARY.

28 Fri. London: Central Ethical Committee, 2 p.m.

FEBRUARY.

1 Tues. London: Grants Subcommittee, 9.30 a.m.
London: Propaganda Subcommittee, 10 a.m.
London: Organization Committee, 11 a.m.

2 Wed. London: Finance Committee, 2.30 p.m.
East Hertfordshire Division, Hertford County Hospital, 2.30 p.m. Lecture, 3 p.m.

4 Fri. London: Medico-Sociological Committee, 2.30 p.m.
London: Naval and Military Committee, 2.30 p.m.

16 Wed. London: Council, 10 a.m.

APPOINTMENTS.

DAVIDSON, Maurice, M.A., M.D. Oxon., M.R.C.P. Lond., Assistant Physician, Brompton Hospital for Consumption and Diseases of the Chest.

STRETTON, John Weston, F.R.C.S. Eng., B.Ch. Cantab., Honorary Surgeon, Kidderminster Infirmary and Children's Hospital.

BIRTHS, MARRIAGES, AND DEATHS.

The charge for inserting announcements of Births, Marriages, and Deaths is 9s., which sum should be forwarded with the notice not later than the first post on Tuesday morning.

BIRTHS.

QUINLAN. On January 20th, at Stanley House, South Reddish, Stockport, the wife of W. T. Quinlan, M.R.C.S., L.R.C.P., of a son.

WATSON. On January 18th, at 33, High Street, Sheerness, the wife of F. H. Watson, M.B., B.Ch. Cantab., of a son.

IN MEMORIAM.

DYER.—In ever loving, proud, and grateful memory of Francis N. Y. Dyer, M.A., M.B., B.Ch. Cambridge, M.R.C.S., L.R.C.P. Lond., Captain R.A.F., late Surgeon R.N., who died of scarlet fever at the London Fever Hospital on January 24th, 1920, where he was Assistant Medical Officer, aged 26, the very dear and only child of Mr. and Mrs. Dyer, East Parade, Harrogate.

SUPPLEMENT TO THE BRITISH MEDICAL JOURNAL.

LONDON: SATURDAY, FEBRUARY 5TH, 1921.

CONTENTS.

	PAGE		PAGE
BRITISH MEDICAL ASSOCIATION		INSURANCE.	
CURRENT NOTES:		DISTRIBUTION OF FUNDS	31
DRAFT REGULATIONS UNDER THE DANGEROUS DRUGS ACT ...	29	MEDICAL RECORDS IN SCOTLAND	31
FEES FOR CASES OF MISCARRIAGE AND ABORTION	29	CORRESPONDENCE	34
SALARIES OF UNIVERSITY TEACHERS AND PROFESSORS	23	LOCAL MEDICAL AND PANEL COMMITTEES	34
THE HALF-YEARLY INDEXES	29	INSURANCE COMMITTEES	35
MEETINGS OF BRANCHES AND DIVISIONS:		NAVAL AND MILITARY APPOINTMENTS	35
WILLESDEN DIVISION	30	DIARY OF SOCIETIES AND LECTURES	35
BLACKPOOL, MID-CHEESHIRE, AND WARRINGTON DIVISIONS ...	31	ASSOCIATION INTELLIGENCE	35
ASSOCIATION NOTICES:		DIARY OF THE ASSOCIATION	35
MEETING OF COUNCIL	31	APPOINTMENTS... ..	36
MOTIONS FOR ANNUAL REPRESENTATIVE MEETING, 1921 ...	31	BIRTHS, MARRIAGES, AND DEATHS	36
CENTRAL MIDWIVES BOARD FOR SCOTLAND	31		
GENERAL MEDICAL COUNCIL: MEDICAL REGISTRATION	31		

British Medical Association.

CURRENT NOTES.

Draft Regulations under the Dangerous Drugs Act.

FURTHER study of the draft Regulations made by the Home Office under the Dangerous Drugs Act of 1920 shows that the first impressions of the far-reaching effect they must have on the work of the medical practitioner, if put in force unmodified, were by no means exaggerated.¹ Four separate books will have to be kept at each surgery or branch surgery: one for cocaine and eegonine, one for morphine, one for heroin, and lastly, one for medicinal opium, and in each case for the substances containing them. In these books must be entered the details of all transactions in these drugs whether incoming or outgoing. Moreover, the entries must be made on the day on which any transaction in them takes place. The books must be open to inspection at any time. As the regulations now stand it would seem clear that entries must be made whenever a hypodermic injection of morphine is given or a morphine suppository is administered.

Apart from the great inconvenience and expense which these regulations will cause to bona fide patients who require medicines containing these drugs, serious objection will be raised by doctors who dispense their medicine to the requirement that the total amount of the drug in the package or bottle (and in case of solutions the amount and percentage of the drug in the solution) must be stated on the label of the bottle or package containing preparations of the drugs in question. The psychological effect of this requirement on many patients, like most other practical points connected with prescribing and dispensing, has been overlooked or ignored by the draftsman.

The British Medical Association obtained a copy of these draft regulations as soon as they were available, and no time was lost in sending a protest to the Home Office. Detailed criticism has been now sent in by the Medico-Political Committee, but individual practitioners can materially assist the campaign for modification of the regulations by writing to the Home Office urging that

the regulations should be held up until there has been consultation with representatives of those chiefly affected by them.

Fees for Cases of Miscarriage and Abortion.

The Association, when trying to assess what would be an adequate fee for attendance on cases of miscarriage and abortion for medical men called in on the advice of midwives, found some difficulty in arriving at a reasonable flat-rate fee in the absence of any data as to what proportion of such cases were really difficult. The fee fixed by the Ministry of Health is one guinea, with a further guinea if an anaesthetist is required. In order to obtain data in the event of future negotiations the Medical Secretary invites practitioners who keep a record of such cases to inform him of the number of cases of this kind to which they are called, and their character—stating whether they are difficult, taking up much time, and giving other particulars. If a sufficient number of examples could be collected it might be possible to determine what flat rate could be considered adequate.

Salaries of University Teachers and Professors.

A special subcommittee is at present engaged in considering the question of the salaries of members of the medical profession who are professors and teachers at university and teaching schools. This subcommittee has the advantage of the assistance of representatives of the Association of University Teachers, and hopes soon to be in a position to report, through the Medico-Political Committee, to the Council in order that a scale of salaries may be submitted to the Representative Meeting for its approval.

The Half-Yearly Indexes.

The usual half-yearly indexes to the JOURNAL and to the SUPPLEMENT and EPILOGUE have been prepared and printed. They will, however, not be issued with all copies of the JOURNAL, but only to those readers who ask for them. Any member or subscriber who desires to have one or all of the indexes can obtain what he wants, post free, by sending a post-card notifying his desire to the Financial Secretary and Business Manager, British Medical Association, 429, Strand, W.C.2. Those wishing to receive the indexes regularly as published should intimate this desire.

¹ See BRITISH MEDICAL JOURNAL, January 15th, 1921, p. 36; SUPPLEMENT, January 29th, 1921, p. 25.

Meetings of Branches and Divisions.

WILLESDEN DIVISION.

Maternity and Child Welfare Work.

At a meeting of the Willesden Division, which was held on January 18th, with Dr. J. S. CRONE, J.P., in the chair, an address was given on the subject of maternity and child welfare work, by Dr. CHRISTINE MURRELL. Two main points, she said, needed consideration:

- (1) What was done at clinics and did it need to be done?
- (2) If this was to be done, what was the best way?

The nature of the work was (i) preventive, (ii) curative, (iii) both combined, and the people dealt with were (a) infants, (b) children, (c) mothers.

In regard to the preventive work, often known as consultations, so far as (a) infants was concerned, this was new work. The Registrar-General's statistics, when first the mortality at various ages was worked out, showed variations between 30 and 130 per 1,000 births. The highest mortality was found in towns and the lowest in rural areas. So enormous a difference pointed to many preventable causes, such as housing and sanitation, both very important, and ignorance in mothercraft—due largely to compulsory education, which took the children out of the home during the ages when they would in the past have absorbed almost unconsciously the way in which to bring up healthy children. This pointed to a need for advisory work. Moreover, the whole range of medicine was permeated by the preventive spirit, a change much to be welcomed; all now recognized the value in health—as in other things—of a stitch taken in time. The value of the awakening of the spirit of competition and interest in the mothers at the consultations, whose life-work was otherwise done in almost complete isolation, was found to be of great value. In the past this work was not done by the general practitioner or obstetrician, and only occasionally by the children's specialist.

The result of the work that has been done was seen in a real lowering of the mortality rate, although undue claims were sometimes made. Increase of health in survivors was shown markedly in the lowered incidence of rickets. Opponents sometimes claimed that patent foods were too much pushed at consultations, but on the contrary, the value of breast feeding was strongly emphasized. The doctor had increased opportunity of observation of infant life and of gaining knowledge in infant feeding. Preventive work, so far as (b) children, was concerned, has already been almost universally adopted in the form of school medical inspection; while the preventive work for (c) mothers was gradually being introduced in the form of ante-natal clinics.

On the other hand, in regard to curative work, this was carried on in infant clinics, in school clinics, and in maternal clinics where both ante- and post-natal work was done. These ranked like the out-patient departments of hospitals and should be dealt with on the same lines. The question as to whether preventive and curative work could advantageously be combined at the same clinics had been much debated. There was no doubt that such a method was most convenient for the patients, saving considerable time; but the originators of the preventive work opposed the combination, as they feared under such a system the curative work would tend to dominate the situation and the preventive be allowed to slide. Dr. Murrell considered that this work was worth doing, but even those who did not agree would probably admit that it was almost certain that it was going to be done. On the point, therefore, of how it should be done it was useless for the profession to criticize schemes put forward unless they had a definite alternative to propose.

There were, she considered, three chief methods of carrying on the work: (1) The present basis, under which the initiative was left to voluntary philanthropic effort, as so frequently happened in British public life. Practically all the preventive work was started in this way, and for this the public was deeply indebted to the originators, but it was too cumbersome as a permanent method. (2) The work might be taken over completely by the local health authority. The disadvantages for the general public was that there was a tendency for the work undertaken in this way to become bureaucratic, and to suffer from a loss of elasticity which was so necessary in medical work. For the profession the disadvantage was that up to the present it had been taken for granted that when anything medical whatever was undertaken by the local health authority it must necessarily be placed under the M.O.H. This was unfair to him, and a retrograde step from the scientific point of view of medicine. Whereas the whole tendency of medicine as knowledge increased was to specialize more and more, here the reverse method was adopted when a medical officer, appointed chiefly for his executive and public health qualifications, was asked to take on the direction of clinical work. In actual practice, it generally drifted into the hands of a junior whole-time medical officer less experienced in the work under his control than the men who had to work under him. This objection might possibly be met by the appointment of a Clinical Medical Officer to the local health authority, who would not be under the M.O.H., but would work side by side with him. (3) The local profession should undertake the work, working in close collaboration with the local health authority.

This method from the administrative point of view was slightly more cumbersome, and in the initial stage would certainly be more difficult, but in Dr. Murrell's opinion it was the best.

The advantages for the general public were that they would get, she believed, what they wanted—namely, personal touch in their dealings with the doctor, and elasticity for meeting local conditions. For the profession the gain was that (1) the professional relationship between all the doctors of a district, which was always a matter needing delicate adjustment, would be much better arranged under such professional control; (2) the relation of the doctor and nurse, which under the local health authority's scheme was apt to be unsatisfactory, would be maintained on its usual professional lines; (3) the divorce between work at the clinic and home visiting could be much reduced, and the relationship of the clinic doctor and the usual medical attendant (when they were not actually the same) remain as close as that between the throat and ear or eye specialist and the general practitioner.

The difficulties, not disadvantages, would be found chiefly in organization and administration. A committee could be formed on the lines suggested in the Dawson Report—namely, a big local health committee with the public health committee of local health authority as its nucleus, and due representation of the local profession, with probably two subcommittees, one lay and the other professional, working in the same relation to each other as the medical and general committees of a general hospital. The clinics, either isolated or as branches of a larger health centre, would receive financial grants from the local health authority, a condition for such grants being that the work reached a required standard. The grants would need careful adjustment, but some such demarcation might possibly be adopted as (a) a grant covering the whole cost, in the case of patients of the insurance level, and (b) partial (for example, equipment expenses, etc.), for patients above the insurance level. In this way also the appointment of whole-time medical officers would be avoided. The appointment of such officers, in Dr. Murrell's opinion, was not fair either to the public or to the officers themselves. Advisory work could not be done well by people who had never had clinical experience, and who were unaware of the home conditions, and therefore suffered from loss of perspective in all their work. Also, for such officers there were very few posts for seniors in their branch of work, and the work itself unfitted them for any other branch of medicine, and those who did not get good promotion were in a few years' time in a sorry case. The most important point was that if the public was to get good clinical medical service the work should be under the control of a medical officer with clinical experience.

Discussion.

After an expression of thanks to Dr. Christine Murrell a discussion followed, in which Drs. SKENE, CORAM JAMES, RAWES, SCOTT, WILSON, and others took part. It was agreed that maternity and child welfare work was bound to progress, and that it was desirable to secure the right of every local practitioner to participate in the work of the clinic if he so chose. It was pointed out that the British Medical Association, and also the Ministry of Health, as instanced by the annual report of the Chief Medical Officer, Sir George Newman, were against a whole-time salaried State medical service. The fact was also referred to that the medical inspection and treatment of school children had originally been carried out by the local practitioners.

Dr. G. C. ANDERSON, Deputy Medical Secretary, British Medical Association, was present at the meeting, and, on being asked to speak, said that the maternity and child welfare question had come to the forefront at perhaps an unfortunate time from the professional point of view, namely, when most general practitioners were serving with His Majesty's Forces, and the general practitioner in many localities felt that they were now placed at a disadvantage in having to deal with what practically amounted to an accomplished fact. The views placed before the meeting by Dr. Murrell were practically the policy of the Association in the matter. It would appear that the only solution to the many problems connected with the medical services undertaken by local authorities was action along the lines of the Report of the Consultative Council. If the profession did not support that Report it might find itself faced with a whole-time salaried State medical service. Referring to the replies of some Divisions to the questions recently circulated by the Association on the Consultative Council's Report, to the effect that the whole idea was far too costly to have put into operation, Dr. Anderson said that the costliness of the complete scheme was admitted by everyone, but the proposals in the Report were intended to be a foundation upon which to build, and it was not necessary that the whole should be put into operation at once. He suggested that the local profession should adopt the proposals of the Report, with a view to securing that the local health services should follow upon the lines thereof, as he felt that the proposal of the Report constituted the great hope for the general practitioner, and it was upon the general practitioner that the health of the community rested.

LANCASHIRE AND CHESHIRE BRANCH: MID-CHESHIRE DIVISION.

THE annual meeting of the Mid-Cheshire Division was held at the Altrincham Hospital on January 18th. Dr. COX, O.B.E., the Medical Secretary, who was accompanied by Dr. Garstang, the Chairman of Representative Meetings, was present, and gave an address entitled: "The claims of the British Medical Association on every section of the medical profession." Dr. Cox developed the subject of his address under the various headings of "consultants," "whole-time medical officers," "the Services," and "the general practitioners," and made out a strong case for the claims of the Association on each of these sections of the profession. He subsequently dealt fully with a number of questions put to him by members.

BLACKPOOL DIVISION.

A MEETING of practitioners of the Blackpool Division, presided over by Dr. McCANDLISH, was held on January 20th when Dr. COX, Medical Secretary, and Dr. GARSTANG, Chairman of Representative Meetings, addressed the meeting.

Dr. COX spoke fully on the claims of the British Medical Association on every branch of the profession, and Dr. GARSTANG dealt with matters of organization and the method of electing the Council. In the discussion which followed, a severe criticism was passed on certain phases of the policy pursued by the Association.

On the motion of Dr. BARTON, seconded by Dr. STEWART, the following resolution was adopted with one dissentient:

That this meeting of medical practitioners of the Blackpool Division strongly condemns the British Medical Association for the feeble and ineffective action invariably taken when dealing with matters affecting the welfare of the profession.

A cordial vote of thanks, proposed by the CHAIRMAN and seconded by Dr. BARTON, was accorded to Drs. COX and Garstang for their attendance at the meeting.

There were twenty-one practitioners present at the meeting, ten of whom were members of the British Medical Association and eleven non-members. Dr. COX and Dr. GARSTANG expressed satisfaction with the interest that had been shown by the meeting, but regretted that members could vote for a resolution which condemned the Association for whose policy they were partly responsible. The hope was then expressed that these gentlemen would again visit the Division.

WARRINGTON DIVISION.

THE annual dinner of the Division was held at the Mirmarleigh Café, Warrington, on January 20th, when Dr. FERGUSON presided. There were twenty-two present, including members and non-members. The CHAIRMAN having proposed the Royal toasts, that of "The Army and Navy" was proposed by Dr. PEACOCKE and responded to by Dr. LEITH MURRAY (Liverpool) and Dr. TASSER, M.C. The toast of "The British Medical Association" was proposed by Mr. HEDLEY TAYLOR, and Dr. J. B. NADEN, J.P., responded. "The Visitors" was proposed by Dr. JOHNSTONE, and Dr. RATCLIFF-GAYLARD replied. Dr. FOX, J.P., proposed the toast of "The Ministry of Pensions," which was responded to by the HONORARY SECRETARY, and that of "The Chairman" was proposed by Dr. LEONARD. Amongst the guests were Dr. Ramsbottom, Mr. Roberts (Manchester), Dr. Leith Murray (Liverpool), Dr. Ratcliff-Gaylard (Birkenhead), Dr. S. E. Critchley, with Mr. Tasker (Carnarvon), Mr. Hedley Taylor and Mr. Forster. Mr. Thelwall Thomas (Liverpool), Professor J. W. Smith (Manchester) and others were unable to be present.

Association Notices.

MEETING OF COUNCIL.

THE next meeting of Council will be held on Wednesday February 16th, in the Council Room, 429, Strand, London, W.C.2, at 10 a.m.

MOTIONS FOR ANNUAL REPRESENTATIVE MEETING, NEWCASTLE, JULY, 1921.

NOTICES OF MOTION by Divisions, Constituencies, or Branches for the consideration of the Annual Representative Meeting of the Association, commencing Friday, July 15th, 1921, proposing to make any addition to, or any amendment, alteration, or repeal of any Article or By-law, or to make any new Article or By-law, or proposing material alteration of the policy of the Association in matters relating to the honour and interests of the profession or of the Association, require to be published in the BRITISH MEDICAL JOURNAL SUPPLEMENT not later than May 14th, and for this purpose should be received by the Medical Secretary not later than April 30th.

BRANCH AND DIVISION MEETINGS TO BE HELD.

METROPOLITAN COUNTIES BRANCH: LEWISHAM DIVISION.—A meeting of members of the Division will be held to-day, Friday, February 4th, at 4 p.m., at 326, Brownhill Road, Catford, S.E.6.

CENTRAL MIDWIVES BOARD FOR SCOTLAND.

THE Scottish Board of Health has announced this week the constitution of the Central Midwives Board for Scotland as from February 1st, 1921, under the terms of the Midwives (Scotland) Act, 1915. The members appointed, with the bodies appointing them, are as follows:

Miss A. H. Turnbull; Miss I. L. Scrimgeour, Miss K. L. Scott. By the Scottish Board of Health.

Sir A. Buchan Hepburn, Bt. By the Association of County Councils for Scotland.

Sir Robert Cranston, K.C.V.O. By the Convention of Royal Burghs of Scotland.

Dr. James Haig Ferguson (Edinburgh). By the Queen Victoria Jubilee Institute for Nurses (Scottish Branch).

Dr. A. Campbell Munro. By the Society of Medical Officers of Health of Scotland.

Professor J. A. Kynoch, M.B. (St. Andrews). By the University Courts of the Universities of Edinburgh and St. Andrews.

Professor Robert Gordon McKerron, M.D. (Aberdeen). By the University Courts of the Universities of Glasgow and Aberdeen.

Dr. Robert Jardine (Glasgow). By the Royal College of Physicians of Edinburgh; Royal College of Surgeons of Edinburgh; Royal Faculty of Physicians and Surgeons of Glasgow.

Dr. Michael Dewar (Edinburgh); Dr. E. H. L. Oliphant (Glasgow). By the Scottish Committee of the British Medical Association.

* Midwives practising in Scotland.

GENERAL MEDICAL COUNCIL.

MEDICAL REGISTRATION.

ONE of the periodical revisions of a part of the *Medical Register* is being made, and practitioners are being circularized by the Registrar of the General Medical Council for purposes of inquiry as to whether they have ceased to practise or have changed their residences. It is of great importance that this inquiry should be answered without delay by the practitioners concerned, and if for any reason a permanent address cannot be given, some other should be supplied to which official communications can be directed. The responsibility of keeping his address correct rests with the practitioner, the *Medical Register* being the official book in which alone the entry of a name confers any legal privileges, and it must not be confused with any of the directories which issue circulars every year. Unless a practitioner's name continues to appear upon the *Medical Register* he is not entitled to recover charges in a court of law; he is not entitled to hold public appointments; nor is a certificate, as required by law, valid unless the practitioner's name be on the *Register*—points that are sometimes overlooked. With this circular from the Registrar, is enclosed a copy of certain important notices from the General Medical Council reiterating its resolutions upon forms of professional misconduct. The importance of a practitioner making certain of the exactitude of every certificate he may write is again emphasized, and as under the Midwives Act (Scotland) of 1915 the provisions of the Midwives Act of 1902 is extended since that date to Scotland (forbidding any woman "habitually for gain to attend women in childbirth otherwise than under the direction of a qualified medical practitioner, unless she be a certified midwife"), it is again pointed out by the Council that, in accordance with this recent enactment, medical practitioners must not knowingly enable uncertified women, under the pretence that such women are under their direction, to attend women in childbirth contrary to law.

REGISTRATION OF MEDICAL STUDENTS.

THE General Medical Council draws attention to the fact that on and after January 1st, 1923, all those who desire to be registered as medical or dental students will have to produce evidence that they have attained the age of 17 years, and the minimum standard of general education required will be that of university matriculation or entrance examination. Before registration as a medical student every applicant will be required to have passed, in addition to the examination in general education, an examination in elementary physics and elementary chemistry, conducted or recognized by one of the licensing bodies. A student who has attended an approved course of instruction in elementary biology at a secondary

school or other teaching institution recognized by a licensing body may be admitted to the professional examination in elementary biology immediately after his registration as a student.

INSURANCE.

DISTRIBUTION OF FUNDS.

A REPORT, dated December 30th, 1920, has been made by the Committee appointed by the Minister of Health to advise as to the basis on which, and the proportions in which, the funds available for remuneration of insurance practitioners for the treatment of insured persons and for mileage should be distributed amongst the Insurance Committee areas in England and Wales.

Central Practitioners' Fund.

The first part deals with the distribution of funds available for treatment. The revised apportionment recommended for 1920 is set out in an appendix. In the main this has been made on the basis outlined in the Committee's previous report dated November 26th, 1919, but the data available in respect of 1920 have been taken into consideration. The apportionment of the fund for 1921 has been considered on similar lines to those adopted for the provisional apportionment for 1920, and the basis on which, in the Committee's view, the respective shares of the several committees should be calculated is shown in a second appendix. In re-examining the 1920 distribution it became apparent that, though the final results were generally in close relation to the figures provisionally adopted, the situation had not yet reached a state of equilibrium after the serious disturbances during the war and during demobilization. Accordingly the Committee recommends that the distribution for 1921 set out in Appendix II should be regarded as provisional only, and should be reviewed towards the end of this year.

Central Mileage Fund.

In its former report the Committee proposed that this fund should be divided into two parts, namely:

(a) That portion required to meet the risks of a country practitioner which can properly be measured with reference merely to distance travelled; and

(b) The remainder to provide additional remuneration where the difficulties of the district are of an exceptional character, and therefore involve extra expense and/or loss of time not met by a grant on the ordinary basis of distance.

A grant of £300,000 having been made for 1920, its distribution was considered in detail. The first question was, What proportion of the total fund should be allotted under (b), in addition to any payments under (a), to districts presenting aspects of special difficulty, and such Insurance Committees as held themselves entitled to participate in this portion of the fund were invited to submit claims. These claims in England were examined by medical officers of the Ministry of Health, who consulted together as to a common standard. The areas were then visited by a medical officer. As a result of these investigations the Committee received reports as to the difficulties facing insurance practitioners in certain parts of the country. In the case of Wales reports were received from doctors in rural areas, and these were in the first place examined in detail by the Welsh Board of Health.

The claims received from the several areas showed much diversity. The main difficulties presented were the necessity of walking over rough country—such as mountain, marsh, or fen—severe gradients, and winter conditions. The Committee now concludes that a larger portion than 5 per cent. of the total fund should be reserved for these difficult areas, and it recommends that £34,900 should be allotted to committees for supplementary payments in respect of difficulties of an exceptional character. As regards the main portion of the Mileage Fund, the Committee recommends a distribution at the rate of 2s. 4d. a unit on the basis of the returns made. The resulting amounts so allotted to committees are set out in Appendix III.

As regards the Mileage Fund for 1921, the Committee recommends that 85 per cent. be provisionally taken as representing the main portion of the fund for the purpose of making quarterly advances to committees on the basis of their unit returns, and that provisional advances be made to the difficult areas, as set out in Appendix III. The closing paragraph of the Report is of special importance:

"It is desirable to draw attention to the difficulties under which your Committee have laboured, so far as the distribution of the Mileage Fund is concerned, owing to the inadequacy of the response on the part of insurance practitioners in England to the Ministry's request for returns. It cannot be too strongly pressed on the profession that it is solely in the interests of the practitioners themselves that the fund should be equitably distributed, and that unless the necessary particulars are furnished by the doctors individually, there is a possible risk of an unequal and anomalous distribution."

MEDICAL RECORDS IN SCOTLAND.

THE following letter has been received by the Scottish Insurance Acts Subcommittee from the Board of Health:

Scottish Board of Health,
83, Princes Street, Edinburgh.
January 7th, 1921.

SIR,

I am directed by the Scottish Board of Health to state that they have had before them the question raised at the recent conference with representatives of your Committee as to refunding to practitioners the cost of postages incurred in connexion with the new medical record procedure to be commenced as from January 1st, 1921. The Board understand from what passed at the conference that a similar question has been raised with the Ministry on behalf of English practitioners.

The Board have given the matter their careful consideration, and they desire to draw the attention of your Committee to the two following points of national difference, namely:

1. The obligation laid upon practitioners in Scotland in terms of the First Schedule to the Medical Benefit Regulations, 1920, is defined as follows, namely: "A practitioner is required to furnish records of the diseases of his patients and of his treatment of them in such form as the Board may from time to time determine." There is therefore a definite obligation on practitioners to send records to Insurance Committees without special remuneration therefor. The Board observe that the corresponding provision in the English Regulations requires the practitioner only to keep such records.

2. In Scotland the obligation of the practitioner to keep medical records is restricted to the recording of certificates of incapacity issued and furnishing an annual summary thereof. The record card adopted for use in England requires the recording by the practitioners of every attendance and visit on his insured patients. The Board are of opinion that the amount of clerical work devolving upon the Scottish practitioner is definitely less than that of the practitioner in England.

Apart from the foregoing considerations the Board desire to add that on the information before them they are unable to regard as reasonable the contention that the annual cost to practitioners is sufficient to justify any special payment. Practitioners should transmit these records to Insurance Committees along with their weekly consignments of medical cards, etc., and in the view of the Board such a method would not involve the practitioner in any appreciable additional expense. The Board are of opinion that no case has been made for any special payment to practitioners.

I am, Sir, your obedient servant,
(Sgd.) H. L. T. FRASER,
Assistant Secretary.

The Subcommittee, at its meeting on January 25th, decided that it could not accept the Board's interpretation of the regulation in this respect, and resolved to advise practitioners not to transmit records to Insurance Committees until arrangements are made for reimbursement of the expenses incurred.

CORRESPONDENCE.

The Medical Guild on the Interim Report of the Scottish Consultative Council.

SIR,—Its public utterances suggest that the Guild's chief end is to vilify the Act and enjoy it forever. Its misfortune is to rest oblivious of the fact that a public problem was put to the medical profession for solution in 1912 and that an analogous problem is put to it now. The problem in 1912 was to place at the service of the employed such medical aid as might be necessary in the prevention and cure of personal illness, and the problem now is to put the same aid at service for the wives and children in the same section of the population. The Consultative Council in their Report recommend as the function of the State "organizing" and "supplementing existing arrangements," and, as a first step, "unification of local authorities concerned with health." As the principle of organization, other than this, they recommend "the family as the normal unit and the family doctor as the normal medical attendant" and as the mediator of any auxiliary health agencies. The rest of their recommendations deal with individual deficiencies, and suggest modes in which they may be met when it is practicable to do so.

On this report the Medical Guild has issued a memorandum with the title "A State socialistic scheme of

medical service for Scotland." In this memorandum of twelve paragraphs the most important statements are either false in fact or false in suggestion. The third paragraph opens: "That the Insurance Act has been a failure from the public health point of view has not been seriously questioned." This is a very serious matter, and if the Medical Guild will face it and apply the methods of science to disentangle the influence of the Act among the conditions of public health since 1913, some discoveries await them. The only test, so far, which has the Act as the main factor in its results is the valuation of the funds for sickness benefit now in progress.

This assertion as history is followed by five paragraphs in which practically each statement is false in suggestion. "The family doctor is to be a State doctor," "The patient a name in a departmental directory," "The wishes of the patient and his family will have no place in a scheme of this kind," "The scheme assumes that the family practitioner is an ignorant and incompetent person, and that there is no second medical opinion or help available for cases in which it is required." This, which is almost more than suggestion, is followed by words that imply that in the days before the Insurance Act no one ever lacked a consultation or laboratory assistance. Happy Edinburgh! Were there no citizens whose economic defect was not covered by medical charity?

The ninth paragraph says "there is no attempt to estimate the cost of this scheme." This statement is quite true; but, as the recommendations of the report are not devised for this year or next, and may, indeed, be forwarded where and when practicable, the Advisory Council would have been even less wise than their critics had they attempted such an estimate, and we may leave its omission to balance the fact that the cost of the absence of the scheme is a no less real charge on the community than the cost of its fulfilment, and that the cost of its absence is collected in illness of those who cannot help themselves and in days of work lost from unfitness that might be prevented.—I am, etc.,

Dundee, Jan. 31st.

R. C. BUIST.

Mileage Records.

SIR,—A circular letter has been sent round from the Ministry of Health to doctors who were selected to keep these records, intimating that records are wanted for a complete year. As one of the doctors keeping a record of travelling in a typical rural area in North Northumberland, I would draw attention to a statement in this circular letter. It is this:

"It will be appreciated that the records already available, which have been kept for the most part under summer conditions only, might be misleading if not checked by further returns obtained in respect of winter months."

Apparently it is assumed that from looking at our mileage records, the difference between summer and winter travelling can be gauged, and I wish to show that it cannot be, for the number of miles will not do it.

It goes without saying that winter travelling is heavier upon both the man and his machine, but I question whether we country doctors travel on an average many more miles, if any more, in winter than in summer. We may have fewer patients in summer, but for all practical purposes we have to visit the same villages and outlying places with the same regularity all the year round. During winter we get more walking to do; we have to walk to places we motor to in summer. Lately, for instance, although we have not had snowstorms yet, we have had excessive rains and floods and gales. Four times this winter I have had to travel eight or nine miles round about to places four miles away owing either to flood water or fallen trees. A medical neighbour of mine recently, in order to reach his home nine miles away, tried three different roads, and was stopped on every one, and he took three hours and made a roundabout journey of fifteen miles to get there during a night of wind and rain. Now, Sir, I wish to point out that these, to us, very serious matters do not appear in our mileage records. We simply put down a certain number of miles day by day, the number of visits to insured and to uninsured persons, and nothing more.

Nothing is recorded of the difficulties, the nature of the roads here in winter, nor the time taken up. Frequently I am absent on a journey perhaps five hours distance, say, twenty miles—and visited not more than four or five people, and have spent two or more hours walking over fields, moors, or impassable roads. Reading our record figures for mileage must be like looking at a map of the district; they give no idea of the labour and time involved in making just a few visits. Now this is what we have to do almost daily through our long North Country winter,

even when we have no snow. When we get our snowstorms we may have to leave our cars behind and walk home—as I had to do last week, but because of flood water I left it at a farm and walked three miles home in the pouring rain. I am sure many country practitioners have a worse time than I have, but these (so-called, or mis-called) mileage returns show nothing of all this, and my claim is that they should. We country doctors do not grumble so much at the miles as such, but at the awful difficulties and the great length of time involved in getting through our country work.—I am, etc.,

Felton, Northumberland, Jan. 23rd.

ROBERT A. WELSH.

Overlapping Ministries.

SIR,—I desire to bring to the notice of the British Medical Association a condition of affairs in regard to a panel patient of mine which I consider calls for some explanation.

The patient presented himself to-day to me for medicine, which he alleged the Pensions Clinic for Dysentery, at Oxford, suggested he should do. He has been attending the clinic for five months. This is the first and only intimation I have had that the patient was attending such a clinic.

The point I desire to bring forward is, that if a department of State intervenes between patient and doctor in the rôle of consultant or what not, it is only right that some intimation should be given to the medical man whose patient he is, if only from the point of view of courtesy, whereas a helpful co-operation in elucidating the case and transmitting laboratory results or suggestions of treatment would be welcome.

I feel that there can be but little semblance between the established etiquette of private practice and that of insurance practice under a State department, in the instance I am quoting.—I am, etc.,

Baubury, Jan. 21st.

A. ALAN FORTY.

** The British Medical Association has on several occasions drawn the attention of the Ministry of Health to the overlapping of work as between that department and the Ministry of Pensions. A further representation upon this matter has now been made to the Ministry of Health.

Evening Surgery.

SIR,—On January 25th we received the following communication from the Insurance Committee for the County of Cambridge:

Dear Sirs,

I am directed by my Committee to inform you that they have had under consideration the surgery hours of doctors (Clause 8 (3) of the First Schedule to the Medical Benefit Regulations, 1920), and resolved that all panel doctors who have not hitherto arranged for evening surgery hours be asked to arrange for same forthwith.

My partner and I have been in practice here for some twenty-five years and have never had any evening surgery, although, of course, we have not refused to attend to any message that may have come in the evening.

Why should doctors be called upon to give up their evenings? The so-called working classes leave off work earlier than they ever did; then why should doctors work more hours? The working classes (if hard work is the qualification for inclusion in the term "working classes," surely doctors have a right to be included) have their half-day a week, their Sundays, and bank holidays—privileges which the doctors do not enjoy.

I was under the impression that panel patients were to be given a free choice of doctors. Panel patients know quite well what doctors have an evening surgery and what doctors have not, so surely they have no cause of complaint if they deliberately select a doctor who has no evening surgery.

If, then, there be no cause of complaint, why should the Insurance Committee order doctors to alter their arrangements forthwith? The question is, Have the Insurance Committees power to make such an order?—I am, etc.,

Royston, Jan. 31st.

C. F. WIGHTMAN.

A Curt Warning.

SIR,—The following extracts from an Insurance Committee circular may be of interest to insurance practitioners. It is in reference to "cases of apparently inadvertent breaches by doctors of the certification rules," and proceeds:

"It is considered that practitioners attending insured persons on behalf of the Committee should now be well acquainted with them, that infringements of them expose a doctor not only to

censure but to monetary penalty, and that such censure and penalty may be looked for in the case of any future irregularities."

It is not difficult to foresee the day when we shall receive similar circulars in reference to our weekly or monthly returns of sick and injured, including cases of P.U.O. and N.Y.D.—I am, etc.,

H. G. LANGDALE-SMITH,

Stechford, Jan. 31st.

The New Motor Taxation.

SIR,—Is the medical profession taking the new motor taxation without a protest? I for one—and there must be hundreds like me—feel the great injustice, and hope that something will be done to remedy a great wrong.

In 1914 I bought an Overland because I could not afford a better. It served my partner while I was with the B.E.F., and I am still using it, not being able to afford another. Now instead of a £5 3s. tax I have to pay £28.

My income is about £1,000 a year (can be verified by income-tax returns), and I have four children, all at school, the eldest 15. My bachelor doctor friends, who are, I dare say, making more money than I am, can afford to buy up-to-date cars with smaller cylinders and a supposed lesser horse-power and they get off with a lighter tax. Where in the name of conscience is the justice?

Can nothing be done for men in my position by our parliamentary representatives, or must we be utterly crushed? Were I not a doctor I would not be able to afford a car, and I can honestly say I do not use it a dozen times a year for pleasure only.

This tax is extortionate. Our cheap cars are going to be millstones round our necks. Why did we get a half-tax concession before and now have to pay the same as a millionaire and the man who simply keeps a car for pleasure?—I am, etc.,

Sandiacre, Notts, Jan. 21st.

CHARLES S. VARTAN.

* The British Medical Association has met the Minister of Transport on several occasions in an effort to obtain some remission of motor-car taxation for medical men. On the third occasion the Association pointed out at a deputation that in its opinion a flat-rate tax on petrol would be preferable to the £1 per horse-power tax. The Minister refused to make any concession and stated that as commercial cars were now being taxed no case could be made out for a concession to any section of the community. Details of action taken by the Association in this matter have appeared from time to time in "Current Notes," in the SUPPLEMENTS of May 1st, May 8th, May 29th, and July 19th, 1920, and also in the JOURNAL of May 15th, p. 685.

Central Insurance Defence Fund.

SIR,—Like many others I had filled up my reply, claiming the balance for myself. Dr. Edwards's suggestion in last week's SUPPLEMENT meets with my heartiest approval, and I hope others will write to Dr. Cox, the Secretary of the Fund. Dr. Cox has assured me that he will see that the subscribers' wishes are carried out, so it is not too late to act. Personally I wish Epsom College to share equally with the Royal Medical Benevolent Fund. Both are needy and deserving of all the support that can be given.—I am, etc.,

Blackpool, Jan. 31st.

JOHN BROWN.

Fees for Doctors called in by Midwives.

SIR,—Regarding the so-called new scale of fees of doctors called in by midwives (for the only real alterations are very slight and not worth the trouble of drawing up a new scale), are we to understand that this scale has been accepted as either reasonable or adequate by the British Medical Association? Personally, I wish to give every assistance to midwives when requiring help, but I cannot accept 2 guineas as a fee for forceps delivery or other difficult case—for instance, those in which turning is required. One almost always gives chloroform in these cases, without calling in another doctor.—I am, etc.,

Bridgwater, Jan. 14th.

R. COATES.

* The Annual Representative Meeting expressed the opinion that the fee of £2 2s. is too small to enable the Association to urge unwilling practitioners to accept it.

Insurance Record Cards.

"N.B.M.A." writes: As a member of the medical profession, which I entered as pupil fifty-four years ago. I must express my surprise at the attitude taken by many of the panel doctors of the present day in objecting to the use of the record cards. In nearly every business house in the country the card system is being adopted, and if we are professional men surely we are business men as well; if not we ought to be, in order to justify

our demands for any increase of pay. I have been on the panel since the commencement, and have kept a record card of every patient, every visit, and every attendance at my surgery, and find no difficulty in keeping them. System only is required, and plenty of time can be given for the examination of each case. My panel on January 1st, 1920, was 2,026. I have taken an extract for the month of March of that year, the busiest month of the year, and can give exact figures for each day of the month as I count up each night the visits paid and the attendances at my surgery of both insured patients, club patients, and private patients. I find the results for March as follows: The attendance of insured patients at surgery for the month numbered 1,037, or an average of 33.14 a day. Club patients, an average of 10 a day; private patients, an average of 27 a day, or a total average of 70 a day for the busiest month of the year. The visits numbered 757 for the whole month, an average of 24 a day, and on the visiting list 45 were insured patients. 16 club patients and 102 private patients. Every record card is marked up with every attendance at surgery, and visits and certificates as given, and attached to each is a copy of the prescription that he last had. Every complaint is noted, also the principal symptoms. This system gives an excellent record of a year's work, although it has never, so far, been used for statistical purposes. I fail to see why every methodical medical man of a business turn of mind cannot do likewise, and then we should have a good case to bring before the Ministry of Health for increased remuneration.

"A. B. C." asks where he can purchase the Dextro filing case for insurance records and envelopes.

LOCAL MEDICAL AND PANEL COMMITTEES.

COUNTY OF LONDON.

Record Cards.—At the meeting of the London Panel Committee on January 25th Dr. J. G. Duncanson, one of the regional medical officers for London, attended in order to explain the new record system. Dr. DUNCANSON said that the practitioner in the first instance had to verify the correctness of the entries on the card as he received it from the Insurance Committee, and to insert particulars of age, occupation, and marriage relation, which he would elicit from the patient when he came for treatment. With regard to the particulars of visits and attendances, certain medical men might prefer to put down on the card merely the date of the first visit and afterwards the total number of visits. If they did this, they should be prepared to furnish at the inspection the day-book or visiting list from which the figures were transferred. A great licence was left to the practitioner in the matter of clinical notes, but such notes would prove of great advantage alike to the practitioner and to any future practitioner under whose care the patient might go. On the question of secrecy he thought that the possibility of misdemeanour by the clerical staff was remote, especially when it was remembered that these were men with positions to lose and that such practices were subject to penalties.

In reply to questions, Dr. Duncanson said that there was no necessity to keep clinical notes of every visit. The clinical note was a note regarding the case, and presumably would be made at the first visit, and only altered later in exceptional circumstances. Asked whether the insured person had the right to refuse to have his diagnosis written on the card, Dr. Duncanson said that that was beyond him to answer. On the question of certificates, Dr. Duncanson said that a practitioner might give a vague certificate (1) when a certificate bearing the actual diagnosis would be prejudicial to the health of the patient, as in cancer or mental disease, and (2) in venereal disease when this was (a) congenital, or (b) acquired innocently, or (c) when the patient had been suffering for more than two years from the disease. On issuing vague certificates the practitioner must take care to communicate with his regional medical officer, stating his reasons for issuing such a certificate and giving the real diagnosis. As for the special intermediate certificate, this was not intended to be issued indiscriminately. If this certificate was not accepted by an approved society, the practitioner should communicate with the regional medical officer, who might then see the patient with or without consultation with the practitioner. In reply to a question, Dr. Duncanson said that a certificate should not be issued in uncomplicated pregnancy so long as the woman was capable of doing remunerative work, and the same criterion—the capacity for doing remunerative work—applied in the case of discharged soldiers undergoing training for another occupation.

A letter was read from the Cheshire Panel Committee urging that a request be sent to the Insurance Acts Committee to summon a conference to deal with the matter of record cards. Dr. E. A. GREGG said that as the London Committee did not recognize the Insurance Acts Committee it could not join in the request, but he urged that a

sympathetic reply be sent to Cheshire. Dr. H. J. CARDALE said that some of the statements in the memorandum circulated by Cheshire were inaccurate, and the London Committee must not give an unqualified endorsement. Ultimately it was agreed that no action be taken on the request of Cheshire, but that the consideration of the form of record card be remitted to a subcommittee.

Complaints against Practitioners.

The London Panel Committee Gazette for January draws the attention of insurance practitioners in London to the advisability of a doctor at once consulting the secretary of the Panel Committee on receipt of the notification of a complaint having been lodged against him by an insured person. "It is much to be desired that no action of any description should be taken without the advice of the secretary having been first obtained. The Panel Committee have secured the services of a firm of solicitors who have made the study of the National Health Insurance Acts and Regulations a speciality, and the secretary is empowered to seek their advice in all cases which raise questions of general interest to doctors on the panel."

WARWICKSHIRE.

THE Warwickshire Panel and Local Medical Committee held its first meeting of the new year at Coventry on January 20th, when Dr. H. TIBBITS (Chairman) presided over a good attendance.

With a view to obtaining close co-operation between the Committee and that of the neighbouring City of Coventry, Dr. W. H. Lowman, Chairman of the latter Panel Committee, was appointed a member to fill an existing vacancy. A letter was reported from the Ministry of Health in reply to one sent by the Committee raising the question of the degree of privilege attaching to confidential information imparted to the Regional Medical Officers of the Ministry under Article 10 of the Terms of Service. In this the Ministry stated that they were not aware that the fulfilment of the obligation referred to would involve the practitioner in any risk of proceedings being successfully taken against him.

Considerable discussion took place with regard to the new scheme of record keeping, opinion being fairly divided as to the degree of difficulty involved in this work. The Regional Medical Officer (Dr. T. M. Carter) attended by the Chairman's request, and the matter was discussed with him. Strong objection was taken by members to any contingent possibility of a routine examination of records by lay officials of the Ministry, and it was agreed that where this might become a necessity in the case of open negligence, the work should be done through the agency of part-time medical officials.

Matters of principle arose on consideration of accounts submitted by the Insurance Committee for review in respect of treatment rendered by practitioners under the local distribution scheme. Certain accounts submitted were for payment of anaesthetist's fees where the anaesthetic had been given in a local hospital. The Committee decided that these accounts being rendered in hospitals "where standard methods operated for rendering professional services" should not be recommended for payment from the local pool. An account for anaesthetic administered for certain dental extractions was not recommended on the ground that the service did not come within the category of those required to be given to the insured. On a review of certain services for which fees had been charged by an insurance practitioner to his insured patient, the Committee decided that surgical treatment in an incomplete abortion where a portion of the placenta was adherent to the posterior wall of the uterus, should not have been the subject of a charge; the service not being outside the ordinary competence of general practitioners in the district.

The dual notification required by the issue of "vague" certificates had been the subject of complaint, practitioners being required under Certification Rule 13 to send a note of clinical details to the regional medical officer and a statement as to the issue of the certificate to the Society. The Panel Committee considered that the procedure allowed by the rule was valuable, and adopted a draft form embodying both sets of notifications. It was decided to ask the Insurance Committee to adopt and print the form for issue to practitioners, this being performable in the middle; that portion appropriate to the Society to be sent under stamped cover to the Committee for forwarding where the Society's address was unknown to the doctor.

WOLVERHAMPTON.

A MEETING of the Borough of Wolverhampton Panel Committee, held on January 4th, the letter from the London Panel Committee suggesting that a separate body be set up to negotiate with the Government in all panel matters was received, and it was unanimously resolved:

That the Wolverhampton Panel Committee strongly opposes any change in the negotiating body and expresses its confidence in and appreciation of the Insurance Acts Committee of the British Medical Association.

NEWPORT, MON.

At a meeting of the Newport (Mon.) Local Medical and Panel Committee on January 12th, the following resolution was carried:

That in the opinion of this Committee the record cards are needless tax on the time of the panel practitioner, and of little use from a clinical or statistical point of view.

INSURANCE COMMITTEES.

COUNTY OF LONDON.

Remuneration of Medical Practitioners.—At the meeting of the London Insurance Committee, on January 27th, it was reported that the amount of the central practitioners' fund for 1920 had been finally determined at £6,675,000. The amount retained to meet claims for the first quarter of the year in respect to the treatment of invalided men was £60,350, leaving £6,614,650 available for distribution amongst insurance committees. The London share of this is 13.53 per cent., or £894,962, less £270 withheld from the Exchequer grant owing to the default of certain practitioners. The Insurance Committee has already paid £863,154 to practitioners for 1920, so that a balance of £31,528 remains to be distributed on the basis of the number of insured persons on practitioners' lists. The amount of the central practitioners' fund for 1921 has been provisionally determined at £6,450,000, and the London Committee's share at £873,330.

Limitation of Practitioners' Lists.—The Committee permitted three insurance practitioners to include up to 4,500 insured persons on their lists, these practitioners having already applied for and received permission to employ permanent assistants. With regard to two others who practised in partnership, and had been granted permission to employ an assistant jointly, the Committee decided to allow each of them to bring his individual list up to 3,750.

Surgery Accommodation.—The Committee decided on a previous occasion that the permission given to certain practitioners to include more than 3,000 insured persons on their lists should be subject to the Committee being satisfied as to the adequacy of the surgery and waiting-room accommodation. On this subject of accommodation the Committee at this meeting appointed the members of a deputation which is to wait upon the Ministry of Health, jointly with a deputation from the Panel Committee.

Prescriptions.—During nine months of last year London insurance practitioners issued 3,553,729 prescriptions. The average cost per prescription was 9.47d., the total cost, £140,201, and the average number of prescriptions per insured person was 0.71.

Medical Records.—Forms of record for 838,500 men and 814,500 women have been issued since January 1st to practitioners in the London area. A motion was on the agenda, supported by Dr. Ethel Bentham, that the Committee record its dissatisfaction with the scheme for the compilation of medical records on account of the expenditure involved, and also on the ground of its inexpediency as "calculated to lessen confidence in doctors and to deter patients from seeking advice." Just as the motion was reached, however, a member representing approved societies drew the Chairman's attention to the fact that a quorum was not present.

Naval and Military Appointments.

ROYAL NAVAL MEDICAL SERVICE.

THE following appointments are announced by the Admiralty: Surgeon Captain R. A. Ross to the *Ganges* for Sick Quarters, Shotley; Surgeon Commanders T. W. Myles, C.B.E., A. C. W. Newport, M.V.O., and A. H. S. Richardson to the *President*, additional, for three months' hospital course; C. R. Rickard to the *Victory*, additional, for Haslar Hospital (temporary). Surgeon Lieutenant Commanders J. G. Dawson and F. J. D. Twigg to the *President*, additional, for three months' hospital course. Surgeon Lieutenant G. G. Newman to the *Cyclamen* on commissioning. Surgeon Lieutenant (temporary) T. L. P. Harries to the *Pembroke*, additional, for R.N. Barracks, (Chatham temporary). Surgeon Lieutenants promoted to the rank of Surgeon Lieutenant Commander: J. D. Bangay, L. F. Strugnell.

ARMY MEDICAL SERVICE.

Colonel J. McD. McCarthy retires on retired pay. Colonel J. R. McMunn, C.B., C.M.G., vacates the temporary appointment of Assistant Director-General. Colonel L. P. More is placed on half-pay, March 22nd, 1920 (Substituted for notification in the *London Gazette* of May 10th, 1920)

ROYAL ARMY MEDICAL CORPS.

Lieut.-Colonel J. Hennessy, C.B., C.M.G., is placed on the half-pay list on account of ill health. Major and Brevet Lieut.-Colonel F. J. Brown, R. of O., relinquishes the temporary rank of Lieutenant-Colonel, November 25th, 1919. (Substituted for notification in the *London Gazette* of May 25th, 1920.)

Temporary Captain H. N. L. Webber relinquishes the acting rank of Major.

The following officers are, receiving a gratuity: Majors J. B. Meldin, R. B. Hole; Captain R. C. Robertson, M.C.

Temporary Captains J. N. Deacon, M.C., and P. Templeton relinquish their commissions and retain the rank of Captains.

The following officers relinquish their commissions:—Temporary Captains and retain the rank of Captain: J. N. Deacon, M.C., P. Templeton, W. S. T. Neville (December 24th, 1919), A. F. Wyatt. Temporary Lieutenant T. B. Pakenham, and retains the rank of Lieutenant.

The notification in the *London Gazette* of February 27th, 1919, regarding temporary Lieutenant C. Fletcher is cancelled. W. A. Lynn to be temporary Lieutenant.

INDIAN MEDICAL SERVICE.

Major-General W. R. Edwards, C.B., C.M.G., K.I.P., has been nominated to be a member of the Council of State.

The services of Captain C. Newcomb have been placed temporarily at the disposal of the Government of Madras (December 4th, 1920).

Captain H. K. Rowntree, M.C., has been appointed to officiate as Assistant Director-General, Indian Medical Service.

Captain E. S. Goss, M.C., has been appointed to officiate as Additional Assistant Director-General, Indian Medical Service.

Major (Temporary Lieut.-Colonel) H. Ross, O.B.E., has been appointed to the staff of the British Mission to Kabul as Medical Officer.

Lieutenants to be Captains: J. M. Shah (December 17th, 1918), J. G. Bird, M.B. (January 23rd, 1920), S. L. Bhatia, M.C. (April 8th, 1920), G. R. McRobert, M.B. (April 13th, 1920), A. C. Chatterji, M.B. (April 17th, 1920), D. Sanjay, M.B. (July 5th, 1920), S. M. A. Faruki, M.B. (July 6th, 1920), M. Fazzal-din, M.B. (July 13th, 1920), G. C. Maitra (July 14th, 1920), H. E. Magee (July 23rd, 1920), L. K. Ledger (August 1st, 1920), B. Basu (August 6th, 1920), P. F. A. Grant, M.B. (August 9th, 1920).

Lieut.-Colonel A. Street has been permitted to retire from the service (June 26th, 1920).

Captain H. H. King appointed sub *pro tempore* to the Bacteriological Department (March 15th, 1920).

The services of Lieut.-Colonel G. Mel C. Smith, C.M.G., have been replaced at the disposal of the Government of the Punjab (December 13th, 1920).

Lieut.-Colonel J. H. Hugo, D.S.O., has been posted as Residency Surgeon in Kashmir (December 13th, 1920).

Major to be Lieutenant-Colonels (December 27th, 1920): A. G. McKeudrick, O. St. J. Moses, F. W. Sumner, H. R. Nutt, W. D. Ritchie, N. E. H. Scott, C.I.E., J. K. S. Fleming, O.B.E., E. C. Hepper, C. E. Southon, O.B.E., G. Fowler, J. Husband, H. B. Foster, G. C. L. Kerans, D.S.O., C. B. McConaghy, H. W. Ihms, E. W. Browne, J. B. Christian, A. Murphy, O.B.E., L. P. Brassey, C. F. Marr, P. L. O'Neill, C.I.E.

The tenure of the appointment of Colonel C. N. C. Wimberley, C.M.G., will reckon from November 3rd, 1919.

Lieut.-Colonel C. M. Goodbody, C.I.E., D.S.O., has been transferred to the temporary non-effective list (November 14th, 1920).

Lieut.-Colonel L. G. Fischer has retired from the service (October 28th, 1920).

SPECIAL RESERVE OF OFFICERS.

ROYAL ARMY MEDICAL CORPS.

Brevet Lieut.-Colonel W. H. G. H. Best is restored to the establishment.

The following Captains relinquish their commissions and retain the rank of Captain: D. C. Pinn, D.S.O., W. E. P. Briggs, E. R. W. Gilmore, S. F. Castell, K. McAlpine, J. L. Rowlands, J. Aitkin.

Captain C. H. Carlton, M.C., relinquishes his commission on appointment to the R.A.M.C.T.F.

TERRITORIAL FORCE.

ARMY MEDICAL SERVICE.

Lieut.-Colonel J. G. Martin, T.D., to be Colonel and Assistant Director of Medical Services, West Lancashire Division.

The announcements regarding Major C. H. Lindsay, C.M.G., D.S.O., R.A.M.C., and Colonel C. H. Lindsay, C.M.G., D.S.O., A.M.S., which appeared in the *London Gazette* of April 9th, 1920, are cancelled.

ROYAL ARMY MEDICAL CORPS.

Lieut.-Colonel P. Paget, T.D., to be Deputy Assistant Director of Medical Services, 42nd (East Lancashire) Division, with pay and allowances of a Major.

Lieut.-Colonel E. L. Gowlland, D.S.O. (late R.A.M.C.), to be Major, with precedence as from March 4th, 1911, and to relinquish the rank of Lieutenant-Colonel.

Major C. H. Lindsay, C.M.G., D.S.O., to be Deputy Assistant Director of Medical Services, West Lancashire Division (April 23rd, 1920).

Major J. B. Scott, M.C. (late R.A.M.C.S.R.), to be Captain, with precedence as from April 1st, 1915, and to relinquish the rank of Major Captains to be Majors: A. A. Hingston, L. Ball, M.C., L. D. Bailey, M.C., T. H. Kenworthy, M.C.

To be Captains: A. H. Crook (late Surgeon Lieutenant, R.N.V.R.), with precedence as from February 23rd, 1918. Captain F. R. Harris (late R.A.M.C.), with precedence from April 1st, 1920; Captain E. F. Skinner (late Captain R.A.M.C.T.F.), with precedence from October 10th, 1911; Captain R. F. Lintock, M.B. (late R.A.M.C.), with precedence as from February 18th, 1919. Captain D. S. Sutherland, from T.F. Res., with precedence as from September 30th, 1912. Major E. Walker (late R.A.M.C.), with precedence as from September 1st, 1913, and to relinquish the rank of Major. Captain C. H. Carlton, M.C. (late R.A.M.C.S.R.), with precedence from January 31st, 1915.

Captain J. E. Dunbar is restored to the establishment.

DIARY OF SOCIETIES AND LECTURES.

LONDON DERMATOLOGICAL SOCIETY, 49, Leicester Square, W.C.—Thurs., 6 p.m., Chesterfield Lecture by Dr. Sibley: Alopecia.

MEDICAL SOCIETY OF LONDON, 11, Chandos Street, W.1.—Monday, 9 p.m., Mr. George E. Gask, C.M.G., D.S.O., F.R.C.S.: First Left-shoulder Lecture: Surgery of the Lung and Pleura.

MIDDLESEX HOSPITAL MEDICAL SCHOOL, W.—Emeritus Lecture, Tues., 3 p.m., Surgeon Rear Admiral Bassett-Smith: Trypanosomiasis.

ROYAL SOCIETY OF MEDICINE.—Section of *Psychiatry*: Tues., 8.30 p.m., Dr. W. A. Potts: Mental Tests. Section of *Surgery*, Subsection of *Proctology*: Wed., 5.30 p.m., Sir C. Gordon-Watson: Fistulae treated by Excision and Primary Suture; Mr. W. B. Gabriel: Results of Investigation of Rectal Fistulae; Mr. H. Greene Anderson: Abdomino-perineal Excision of Rectum. Section of *Neurology*: Thurs., National Hospital for the Paralysed and Epileptic, Queen Square, W.C.1., 8 p.m., Joint Meeting of *Clinical Medicine and Surgery Sections*, Fri., 5 p.m., Discussion: 'The Medical and Surgical Treatment of Graves's Disease, to be opened by Dr. Hector Mackenzie and Mr. James Berry. Section of *Ophthalmology*, 8 p.m., Cases, 8.30 p.m., Mr. B. T. Lang: Scotometry; Dr. T. Harrison Butler: Late Infection after Strabismic; Mr. M. L. Hepburn: Trephining.

POST-GRADUATE COURSES AND LECTURES.

GLASGOW POST-GRADUATE MEDICAL ASSOCIATION, Royal Asylum, Gartnavel.—Wed., 4.15 p.m., Dr. Henderson: Mental Cases.

HOSPITAL FOR SICK CHILDREN, Great Ormond Street, W.C.—Thurs., 4 p.m., Dr. Nabarro: Congenital Syphilis.

LONDON LOCK HOSPITALS.—Daily Clinics, Lectures (Male Hospital, Dean Street), Mon., 5 p.m., Mr. Gibbs: Complications in Treatment of Syphilis; Tues., 2.30 p.m., Mr. McDonagh: Metallic Intoxication; 5 p.m., Mr. Juler: Fundus, Orbit, and Neuro-

muscular Apparatus; Wed., 4.30 p.m., Mr. Joly: Chronic Gonorrhoea in the Male; Fri., 4 p.m., Mr. Abraham: Late Sequelae in Gonorrhoea in the Female.

MANCHESTER: ANCOATS HOSPITAL.—Thurs., 4.30 p.m., Dr. Morrison: Radiographical Demonstrations.

MANCHESTER BABIES' HOSPITAL, Onward Buildings, Deansgate.—Sat., 3.30 p.m., Dr. Dyson: Skin Diseases in the Infant.

MANCHESTER ROYAL INFIRMARY.—Tues., 4.30 p.m., Dr. H. R. Dean: Pneumococcus and the Serum Treatment of Pneumonia.

NATIONAL HOSPITAL FOR DISEASES OF THE HEART, Westmoreland Street, W.—Mon., 5.30 p.m., Dr. F. W. Price: Arterial Pulse.

NATIONAL HOSPITAL FOR THE PARALYSED AND EPILEPTIC, Queen Square, W.C.—Daily (except Wed. and Sat.), 2 p.m., Out-patient Clinics. Lectures.—3.30 p.m., Mon., Dr. K. Wilson: Old and New Afferent Systems; Tues., Dr. Collier: Cerebral Vascular Lesions; Thurs., Dr. Buzzard: Neuritic Affections; Fri., Mr. Sargent: Cerebral Abscess.

NORTH-EAST LONDON POST-GRADUATE COLLEGE, Prince of Wales's General Hospital, Tottenham, N.—Daily, 2 p.m., In- and Out-patient Clinics, Operations, etc. Lecture-demonstrations.—Mon., 4.30 p.m., Mr. Banister: Heart Disease in Pregnancy; Tues., 3 p.m., Dr. Metcalfe: Electrolysis in Surface Diseases; Wed., 4.30 p.m., Mr. N. Fleming: Eye Disease; Thurs., 3 p.m., Dr. Hadfield: Anaesthesia; Fri., 3 p.m., Mr. Benians: Clinical Pathology.

ST. MARY'S HOSPITALS, Manchester, Whitworth Street West Branch, Fri., 4.30 p.m., Dr. Fletcher Shaw: Caesarean Section.

WEST LONDON POST-GRADUATE COLLEGE, Hammersmith, W.—Daily, 10 a.m., Ward Visits; 2 p.m., In- and Out-patient Clinics and Operations. Lectures.—5 p.m., Mon., Dr. Saunders: Digestive Disturbances of Old Age; Tues. and Fri., Mr. Baldwin: Appendicitis; Wed., Mr. Armour: Abdominal Tumours; Thurs., Dr. Porter: Epidemic Diarrhoea.

British Medical Association.

OFFICES AND LIBRARY, 429, STRAND, LONDON, W.C.2.

Reference and Lending Library.

THE READING ROOM, in which books of reference, periodicals, and standard works can be consulted, is open to members from 10 a.m. to 6.30 p.m., Saturdays 10 to 2.

LENDING LIBRARY: Members are entitled to borrow books, including current medical works; they will be forwarded, if desired, on application to the Librarian, accompanied by 1s. for each volume for postage and packing.

Departments.

SUBSCRIPTIONS AND ADVERTISEMENTS (Financial Secretary and Business Manager, Telegrams: Articulate, Westland, London), MEDICAL SECRETARY (Telegrams: Medisera, Westland, London), EDITOR, *British Medical Journal* (Telegrams: Atiology, Westrand, London). Telephone number for all Departments: Gerrard 2650 (3 lines).

SCOTTISH MEDICAL SECRETARY: 6, Rutland Square, Edinburgh. (Telegrams: Associate, Edinburgh, Tel.: 4361 Central.)

IRISH MEDICAL SECRETARY: 16, South Frederick Street, Dublin. (Telegrams: Bacillus, Dublin, Tel.: 4737 Dublin.)

Diary of the Association.

FEBRUARY.

- 4 Fri. Lewisham Division, 326, Browbill Road, Catford, S.E.6, 4 p.m.
London: Medico-Sociological Committee, 2.30 p.m.
London: Naval and Military Committee, 2.30 p.m.
10 Thurs. London: Ministry of Pensions Subcommittee, 2.30 p.m.
16 Wed. London: Council, 10 a.m.
24 Thurs. London: Dominions Committee, 3 p.m.

MARCH.

- 2 Wed. Camberwell Division.

APPOINTMENTS.

FORBES, Joseph, L.R.C.P., L.R.C.S. (Irel.), Assistant House-Surgeon to the Doncaster Royal Infirmary.

HENRY, Miss Lydia M., M.D. Sheffield, Assistant Medical Officer for the Borough of Blackburn.

O'DWYER, D. M., M.B., B.Ch., Senior House-Surgeon, Doncaster Royal Infirmary.

POWELL, A., M.D. Lond., Medical Superintendent North Wales Sanatorium, Llangwyfan, vice D. B. Evans, M.R.C.S., L.R.C.P., resigned.

STALEY, M. E., M.B. Lond., Medical Officer for the Colonial Medical Service in Fiji.

VALENTINE, J. A., B.A., M.D. Dub., D.T.M. and H. Camb., Ophthalmic Surgeon, Portsmouth, and Southern Counties Eye and Ear Hospital.

WALFORD, Harold R. S., M.R.C.S., L.R.C.P., Senior Assistant Physician, Union of South Africa Mental Hospital Service.

WHITEFORD, C. Hamilton, M.R.C.S., L.R.C.P., Consulting Surgeon to the Great Western Railway, Plymouth Centre.

BIRTHS, MARRIAGES, AND DEATHS.

The charge for inserting announcements of Births, Marriages, and Deaths is 9s., which sum should be forwarded with the notice not later than the first post on Tuesday morning, in order to ensure insertion in the current issue.

MARRIAGE.

McKERROW-BEETEE.—On January 25th, at St. Matthew's Church, Walsall, by the Rev. B. F. Rilton, M.A., Mungo, youngest son of Dr. McKerrow, Worthington, to Ida, second daughter of Mr. John Beebee, Walsall.

SUPPLEMENT

TO THE

BRITISH MEDICAL JOURNAL.

37-

LONDON: SATURDAY, FEBRUARY 12TH, 1921.

CONTENTS.

	PAGE		PAGE
DANGEROUS DRUGS REGULATIONS: Memorandum from the British Medical Association to the Home Secretary ...	27	INSURANCE CORRESPONDENCE	
ASSOCIATION NOTICES:		THE NEW SYSTEM OF MEDICAL RECORDS. By Sir	
MEETING OF COUNCIL ...	38	WILLIAM HUDSON ...	39
MEMORANDUMS FOR ANNUAL REPRESENTATIVE MEETING ...	38	DIARY OF SOCIETIES AND LECTURES ...	40
BRANCH AND DIVISION MEETINGS TO BE HELD ...	28	ASSOCIATION INTELLIGENCE ...	40
MEETINGS OF BRANCHES AND DIVISIONS ...	78	DIARY OF THE ASSOCIATION ...	40
NAVAL AND MILITARY APPOINTMENTS ...	40	APPOINTMENTS ...	40
		BIRTHS, MARRIAGES, AND DEATHS ...	40

DANGEROUS DRUGS REGULATIONS.

PROTEST BY THE BRITISH MEDICAL ASSOCIATION.

The following letter and memorandum were addressed on February 3rd to the Home Secretary by the British Medical Association:

4.9, Strand, W.C.

Sir,

I have the honour to forward the enclosed memorandum concerning the draft Regulations made by the Secretary of State under Section 7 of the Dangerous Drugs Act of 1920.

The Association wishes to impress on you, Sir, that the medical profession is seriously alarmed at the prospect which the proposed operation of the Regulations opens up. The responsibilities and anxieties of medical practitioners—already great—seem likely to be seriously increased by clerical work and restrictions of a kind hitherto unknown in medical practice.

The Association trusts that you will withdraw the Regulations pending consideration of the question *de novo* in conference with representatives of the medical, dental, veterinary, and pharmaceutical professions; or, failing that, that you will allow this Association to state its objections to the Regulations by a small deputation.

Yours obediently,

ALFRED COX,
Medical Secretary.

The Secretary of State for Home Affairs,
Home Office, Whitehall.

MEMORANDUM

SUBMITTED BY THE BRITISH MEDICAL ASSOCIATION TO THE SECRETARY OF STATE FOR HOME AFFAIRS CONCERNING DRAFT REGULATIONS MADE BY THE SECRETARY OF STATE UNDER SECTION 7 OF THE DANGEROUS DRUGS ACT, 1920 (10 and 11 Geo. 5, Ch. 46).

1. The British Medical Association is well aware of the public danger arising from the improper use of the drugs whose manufacture, sale, possession and distribution it is proposed to control under these Regulations, and has on several occasions urged the necessity of such control. It further recognizes that in consequence medical practitioners must submit to the imposition of certain restraints in prescribing, compounding, dispensing and administering these drugs, and of certain clerical duties in recording their transactions in them.

2. But it appears to the Association that the Regulations as drafted will have effects far beyond those contemplated in Section 7 of the Dangerous Drugs Act of 1920, under which they are made and which states expressly that they

are to be "for the purpose of preventing the improper use of the drugs to which this part of the Act applies."

3. On the one hand, the medical profession will be hampered in its legitimate use of these drugs in treating the sick, and on the other hand the public will be inconvenienced by delay in obtaining medicines necessary for their treatment, and may even in some circumstances be deprived of remedies which, properly used, are invaluable in the relief of pain and in the saving of life. The cost of medicines containing these drugs must also be seriously increased if the restrictions contained in the Regulations are enforced.

4. As it is understood that it is necessary for the Regulations to be brought into force at an early date owing to the probable early lapse of the powers under the Defence of the Realm Regulation 40 B, some detailed criticisms of the draft Regulations in so far as they affect medical practitioners are herewith submitted. These criticisms must not, however, be regarded as complete.

5. The Association regrets that, so far as it is aware, no opportunity was afforded to any body representing the medical profession, or any other of the professions concerned, to give advice on the practical side of the question before the opinions of the Home Office were crystallized into draft Regulations. The Association knows by long experience how much easier it is to influence such regulations while they are in a fluid state and before they have been made public.

Regulation 5.

"Prescription must be in writing."

(a) Some medical men typewrite their prescriptions. It is difficult to see that this favours any improper use of the drugs, provided that the other provisions as to date, address, signature, and qualifications are carried out.

(b) Prescriptions, particularly in hospital work, may be printed—for example, where a stock mixture is ordered, and to this a scheduled drug may be added.

"And marked with the words 'Not to be repeated.'"

This appears to be totally unnecessary, as it is fully provided for by Regulation 6 (a) and (b).

"A prescription for the use of the drugs must be given by a duly qualified medical practitioner, and must comply," etc.

This appears to forbid every personal administration of the drugs by a duly qualified medical practitioner, or under his direct personal supervision, unless he writes a prescription in each case. In hospital practice particularly this would be impracticable. (See below.)

Regulation 6.

This Regulation should not apply to a medical practitioner dispensing his own medicines. It is customary to enter all prescriptions in a day-book, showing the name and address of the patient to whom supplied and the date on which supplied.

If this Regulation be enforced it appears that it will be necessary to keep four records of each transaction:

1. The customary record in the day-book of the service given to the patient and all medicines supplied, including, perhaps, things additional to the scheduled drug.
2. The prescription for the scheduled drug under Regulation 6 (b).
3. The record of the ingredients of the prescription, etc., in a special book under Regulation 6 (c).
4. The record in a special book for the special drug under Regulation 9 (b) and (c).

Regulation 8.

As drafted, the Regulation seems to demand that every mixture containing any of the scheduled drugs or preparations, even though the percentage may be below that laid down in Regulation 1, must have plainly marked on it the amount of the drug contained. This is probably not intended, as it would bring in such medicines as ordinary cough mixtures and the like, which appear to be expressly excluded from the operation of the Dangerous Drugs Act.

In any case the Regulation should not be applied to articles dispensed in pursuance of a prescription given by a duly qualified medical practitioner or to articles dispensed by a duly qualified medical practitioner for the personal use of his own patient, for two reasons:

1. Nervous and apprehensive patients would hesitate or even refuse to take or use medicines so labelled.
2. All patients taking or using these drugs on their doctor's prescription would become aware of the fact and also of the exact nature and dose of the drug prescribed. The objections to this are obvious and have been recognized in the nomenclature of the *British Pharmacopoeia*, which in the case of at least some preparations of opium disigns the fact that they contain this drug by giving them the name of some inert component—for example, opium pill is called *pilula saponis composita*, and opium suppositories are called *suppositoria plumbi composita*.

This Regulation will, in fact, not carry out the "purpose of preventing the improper use of the drugs to which this part of this Act applies," to quote Section 7 of the Dangerous Drugs Act, but will have exactly the contrary effect.

Regulation 9.

As applied to medical practitioners these records appear to be unnecessarily complicated.

- (1) Clause (a): One book might be substituted for four books.
- (2) Clause (c): The entry of the drugs purchased or obtained on the day on which the drug is received is not always feasible. Drug hampers are not always unpacked on the day of receipt.
- (3) Clause (d): Separate books at each set of premises. This would involve a set of books at every branch surgery and at every practitioner's private house, apart from his main surgery, as it is necessary to keep a small supply of such things as opium pill, chlorodyne, and hypodermic tablets of morphine always ready for personal administration in case of emergency.
- (4) Clause (g): Information as to purchases, stocks, and transactions. This would involve a complete record of every use of any of these drugs, and would be quite impracticable to a busy practitioner. By far the largest amounts would be used in compounding mixtures whose strength is below that laid down in Regulation 1. There is also a considerable waste—for example, in giving hypodermic injections, throwing away old stock, and the like.

Regulation 13.

This Regulation would appear to interfere with the delivery of the drugs to persons licensed or authorized to possess them without their signed authority in writing. This would be troublesome in the case of railway and other carriers; very awkward where a doctor wanted a supply in emergency and wished to telephone to his chemist to send some at once instead of giving a written authority to a messenger and sending it by hand; and quite impossible in the case of a patient with a sudden attack of, for example, gall-stone colic, or with severe haemoptysis needing immediate treatment.

6. *Matters requiring to be Adequately Provided for in Draft Regulations.*—Personal administration of the scheduled drugs by a medical practitioner—for example:

- Instillation of cocaine into the eye in testing refractions or examining the eye, or in eye operations;
- Spraying the throat or nose with cocaine for purposes of examination or operation;
- Injecting cocaine as a local anaesthetic;
- Hypodermic injection of morphine or heroin;
- Administration of morphine suppositories.

It is not clear how these procedures are to be carried out under the Regulations. Must a prescription be written out in each case? Must a record be kept for each case as laid down in Regulation 6? In how far will it be legal to depute personal administration to nurses and to hospital orderlies?

In small hospitals without resident house-surgeons, in nursing homes, and in private practice where a trained nurse is in attendance, it is a common occurrence to leave a hypodermic injection or a sedative draught which would contain one of the scheduled drugs, to be given if neces-

sary. Would this be in conformity with the Regulations, or would the nurse or orderly be a person not authorized to be in possession of the drug?

7. The Association would urge the Secretary of State to defer the operation of the Draft Regulations until the representatives of the medical, dental, veterinary, and pharmaceutical professions have been consulted. If this is not granted, the Association would press upon the Secretary of State to receive a deputation which could place more fully before him the reasons which have convinced the Association that the Regulations are so impracticable that they are bound to be ignored or evaded on a very extensive scale.

Association Notices.

MEETING OF COUNCIL.

THE next meeting of Council will be held on Wednesday, February 16th, in the Council Room, 429, Strand, London, W.C.2, at 10 a.m.

MOTIONS FOR ANNUAL REPRESENTATIVE MEETING, NEWCASTLE, JULY, 1921.

NOTICES OF MOTION by Divisions, Constituencies, or Branches, for the consideration of the Annual Representative Meeting of the Association, commencing Friday, July 15th, 1921, proposing to make any addition to or any amendment, alteration, or repeal of, any Article or By-law, or to make any new Article or By-law, or proposing material alteration of the policy of the Association in matters relating to the honour and interests of the profession or of the Association, must be published in the BRITISH MEDICAL JOURNAL SUPPLEMENT not later than May 14th, and for this purpose should be received by the Medical Secretary not later than April 30th.

BRANCH AND DIVISION MEETINGS TO BE HELD.

METROPOLITAN COUNTIES BRANCH: CAMBERWELL DIVISION.—A meeting of the Camberwell Division will be held on Wednesday, March 2nd, when Dr. H. C. Cameron, of Guy's Hospital, will give an address on Children.

METROPOLITAN COUNTIES BRANCH: WILLESDEN DIVISION.—A meeting of members and non-members will be held on Tuesday, February 15th, at 8.30 p.m., at St. Andrew's Parish Hall (Institute behind Church), High Road, Willesden Green, N.W. The meeting will consider proposals made by the Medical Officer of Health of Willesden, at the request of the Committee, for staffing the clinics with part-time medical practitioners. Dr. Anderson, Deputy Medical Secretary, has been instructed by the Council of the British Medical Association to advise and assist the Division in preparing a scheme for working clinics, and will be present.

SUSSEX BRANCH: CHICHESTER AND WORTHING DIVISION.—A meeting of the Division will be held at the Steyne Hotel, Worthing, on Wednesday, February 16th, at 6.30 p.m. At 6.45 p.m. Dr. A. F. Hurst, Physician and Neurologist to Guy's Hospital, will give an address on Asthma. Members wishing to stay for dinner (price 7s. 6d.) are requested to notify Dr. H. Milbank-Smith, Worthing Lodge, Worthing, by Monday, February 14th.

Meetings of Branches and Divisions.

METROPOLITAN COUNTIES BRANCH: CITY DIVISION. A MEETING of this Division was held on January 27th at the Metropolitan Hospital. Dr. E. W. GOODALL delivered an address on the "Nervous group of the acute infectious fevers." The members were very interested in the lecture, which was comprehensive and exceedingly useful from a practical point of view. A hearty vote of thanks was accorded to Dr. Goodall for his kindness in delivering the lecture.

SOUTHERN BRANCH: PORTSMOUTH DIVISION. *Dangerous Drugs Regulations.*

At a meeting of the Executive Committee, Portsmouth Division, held on February 3rd, the following resolution was unanimously adopted:

We, the members of the Executive of the Portsmouth Division of the British Medical Association, having read the proposed regulations for the sale of dangerous drugs, etc., emphatically protest against their application to medical men, as it is utterly impossible to carry them out: the result will be, either that the practitioner will be bound to ignore the regulations or his patients will be deprived of valuable and anodyne drugs, and thereby their sufferings will go unalleviated.

It was also resolved that copies of this resolution be sent to the Home Secretary, to local members of Parliament, and to the medical press.

INSURANCE.

CORRESPONDENCE.

The New System of Medical Records.

SIR,—The Insurance Acts Committee of the British Medical Association is issuing a memorandum on the character of the new system of medical records, which will be found to be more or less a defence in favour of their acceptance by the panel practitioner.

I believe the memorandum is divided into three parts, the first being a history of what has led up to the institution of the records, and the remaining parts will be mainly a critical defence of their favourable reception.

As to the first part, which concerns history, I have very little to say. It seems to me to be a correct and fair statement. As a matter of fact, this system was laid before the last Panel Conference held in London, and duly accepted by that conference for trial. I was not present at that conference, and do not feel justified in agreeing with the decisions of the conference. I am under the impression that the full nature of the new system was hardly comprehended by the delegates when they determined to give it a trial. Previous conferences have passed some very definite lines of liberty which should characterize any new form of records to be introduced. For instance, it was determined by a special conference in July, 1919, that the "Commissioners be requested to devise some simpler form in order to make work less onerous"; and again at the same conference, "that whilst not objecting to the principle of records in a simple form, the conference strongly opposed any complex system involving a multiplicity of forms with a consequent increase in clerical work."

I am under the impression that the last conference, which accepted the present record system, hardly comprehended the complexity of the system, accompanied as it is with multiplicity of forms and consequent increase in clerical work. However, they resolved that the new system should be given a trial, and the Insurance Acts Committee was perfectly justified in taking the view that it was their duty to smooth the way, so far as possible, for a fair trial to be given to the new system.

The trial is now in operation, and there are very varied accounts from different parts of the country as to their being received with favour or disfavour. I am told that in Lancashire there is an opinion favourable to the new system, a statement which surprises me considerably, for my own county entertains a very strong feeling of antagonism towards the system, which they consider alike complex, accompanied with an undue multiplicity of forms and burdensome pressure of increased clerical work. It seems to me, therefore, that it is opportune from the commencement to discuss the working of this system in its trial in the initial stages, and I think there should be ample opportunity given for the expression of the views of panel practitioners upon the bearing which this system has on their professional life. I am bound to admit that we have, more or less, deserved what we have got, but I do not think we should, any of us, be deterred from the expression of our opinions of the system now that it has come.

If the system is to remain, the wisdom of which I gravely doubt, it should, to my mind, be made less burdensome to the practitioner, and much less inquisitorial into the ailments of insured persons. If any records of ailments are to be made it seems to me they should only be those of a serious, acute, or preventable character, in which there may be shown to be some local circumstances, in the districts where insured persons dwell, which may require the more efficient oversight of sanitary authorities.

It is said that there is no obligation to enter notes in these records of every trivial illness or symptom. I do not so read the Regulations, for I think the intimation is quite clear that all ailments of every kind are to be entered in the records, and we must take the thing for what it is, and not what it ought to be, if we are to estimate its true value. An entry is certainly to be made in the column headed "Diagnosis" "when a definite and reasonably certain conclusion" has been arrived at. Thus if a married or unmarried woman has a miscarriage it must be entered as such. A spade must be called a spade, and not an excusable or inexcusable shovel.

The entry of all consultations and visits is required. If that means anything, it must imply what the word states, and every single consultation should find its place in the record. To my mind, also, it is necessary to enter every certificate that is given, though there seems a desire to prune down the record of the number of certificates. Whatever we may desire in this respect, I gather from the Regulations that all consultations and certificates must be

entered, and not simply the first and the final certificates. In other words, all intermediate certificates should, in my judgement, according to the said Regulations, find their due entry. If there is to be any alteration of detail, the sooner pronouncement is made on that matter the better, because there is a great diversity of opinion as to the extent of the obligation of the entries which will have to be made in the records.

I am unable, also, to sympathize with the protest against the comment in what is called the "Political Press." Doubtless every opportunity is taken for every act of a departmental official of the Government to be brought within the range of adverse criticism if the policy of the paper so dictates, but surely we have nothing to do with that. The protest of panel practitioners if they object to this system is not a political protest against the Government, but a professional and personal objection to the incidence of the burden which departmental officials are placing upon panel practitioners. Whether the Press approves or disapproves is a matter entirely for them, and we should be surely justified in making use of any portion of the public press which voices the sentiment of the profession for the time being. In this matter we have nothing to do with political quarrels. We are taking a purely business and not political view of this matter, and I hope we shall endeavour to keep outside the sphere of the party political game. Whatever it may be, we should have no part or lot in that sort of thing.

A good deal has been said in some papers by way of protest against the infringement of secrecy, which has hitherto prevailed between the medical practitioner and his patient in the matter of the privacy of the professional consultation which has taken place between them, and it has been said that too much has been made of this charge of violation of secrecy. To my mind, it is impossible to say too much about anything, whether it is legislative or departmental administration, which interferes with the privacy of a citizen's ailments. The State has no business to exercise an inquisitorial investigation into matters of private concern. If the individual is suffering from a preventable disease of an infectious or contagious character, then it becomes a matter not of private but of public interest, and legislation has very properly dealt with that matter: but the poor and the rich are all treated alike in that respect. The peer of the realm or the pauper in any parish are equally notifiable if they suffer from infectious diseases, but beyond that the general practitioner finds an alteration of the treatment of the individual, according to whether he may or may not be an insured person.

Departmental administration says that it will acknowledge no private right of the individual in this respect. There, it seems to me, a grave departure in the equality of the treatment of individuals has taken place. Why should certain people who are better off, so as to be outside the insurance scheme, be treated more favourably than those who are obliged, perforce by economic circumstances, to be numbered as insured persons, to be ticketed and labelled with all their ailments, in the same way as paupers have always been treated under the Poor Law system? It is the introduction of that antiquated system in a new form, and to my mind is highly objectionable. After all, illness is no respecter of persons. Kipling has put the solid truth in this matter when he said:

"For the Colonel's lady and Judy O'Grady
Are sisters under the skin."

Why should the colonel's lady be exempt from finding a place on the ailments schedules of Government departments while her poorer sister, Judy O'Grady, is duly labelled, ticketed, and docketed? That is exactly what has happened. One can readily see how this sentiment finds its reflection in a great deal of uneasiness which is being felt by insured persons, and, I think, not without reason. No Government department has any right to treat Mary Ann differently than it will treat her mistress the Lady Jane. The Lady Jane is exempt from interference, but her maid, Mary Ann, must go on the schedules. Lady Jane may be a far more dangerous person than Mary Ann, but Government authorities would not dare to bring her within the schedules of ordinary ailments.

There is another matter which I think to the panel practitioner is of grave moment. We have been frequently told, when discussions have taken place on the subject, that it was never intended that the panel practitioner should be subject to any regular inspection in his work. Panel conferences have protested against it, and we have always been assured that no system of inspection would ever take place, but now it appears that these district officers, regional or otherwise, "or such other persons as they may appoint for the purpose," forsooth, are to have access

at all reasonable times to these records, and we are to furnish them with any necessary information with regard to the entries therein which they may require. This is a gross betrayal, and, if we are to submit to it, will be a surrender of all the present liberty in the exercise of our professional duties which hitherto we have always enjoyed. We are to be inspected, forsooth, at every turn in all our panel work. To my mind this is State inspection with a vengeance, and the commencement of what will be infinitely worse in detail as time goes on, unless we can destroy the obnoxious innovation. We said we would not, we have always said we would not, and I hope we shall say we will not submit to this system of inspection.

This system was to have a trial. The trial is with us now. We have put the shoes on, and we have a right to say where they pinch.

I hope that some of the most objectionable features of this record system will soon be revised and altogether withdrawn. It is quite possible to devise a simple system which would be useful and helpful as between practitioner and practitioner in the interests of patients, but it would not be this system of medical records.—I am, etc.,

Crewe, Feb. 6th.

WILLIAM HODGSON.

Dr. G. YOUNG EALES (Torquay) writes: "In the SUPPLEMENT of February 5th, page 34, A. B. C. asks where he can purchase the Dextro filing case for insurance record envelopes. The address is Dextro, Ltd., 30, Arcade Chambers, St. Mary's Gate, Manchester. The case is cheap, handy, and convenient."

Several other correspondents have been good enough to send this information.

Naval and Military Appointments.

ROYAL NAVAL MEDICAL SERVICE.

THE following appointments are announced by the Admiralty: Surgeon Commanders J. H. Lightfoot to the *Conqueror*, J. Boyan to the *Dolphin*, C. T. Baxter to the *President*, additional, for R.N. Recruiting Headquarters. Surgeon Lieut. Commander F. C. Wright to the *Birmingham*. Surgeon Lieutenants F. L. H. McPowel to Haulbowline Hospital and Dockyard, J. C. Brown to Special R.M. Battalion, H. B. Parker, D.Sc., to the *Undaunted* for voyage.

ARMY MEDICAL SERVICE.

ROYAL ARMY MEDICAL CORPS.

Lieut.-Colonel A. E. Master retires on retired pay.
Lieut.-Colonel J. D. G. Macpherson is placed on retired pay on account of ill health contracted on active service.

DIARY OF SOCIETIES AND LECTURES.

HARVIAN SOCIETY, Town Hall, Harrow Road, Paddington—Thurs., 8.30 p.m., Dr. Wm. Brown: Psycho-analysis.

HENTERTIAN SOCIETY, Sion College, The Embankment, E.C.—Wed., 9 p.m., Oration by Dr. H. H. Bashford: The Ideal Element in Medicine.

MEDICO-LEGAL SOCIETY, 11, Chandos Street, W.1.—Thurs., 8.30 p.m., Dr. Halliday Sutherland: Medical Evidence in the Stanton Murder Trial.

MEDICAL SOCIETY OF LONDON, 11, Chandos Street, W.1.—Mon., 8.30 p.m., Discussion on Skin Disease: Its Relation to Internal Disorder, to be introduced by Sir James Gallova, followed by Dr. Arthur Hall, Dr. E. W. Goodall, Dr. A. Whitfield, Dr. E. Graham Little, Dr. H. W. Barber, Dr. H. G. Adamson, Dr. J. M. H. MacLeod, Dr. H. MacCormac, and Dr. K. Hutchison.

ROYAL COLLEGE OF PHYSICIANS, Pall Mall East, S.W.—Thurs., 5 p.m., Dr. Martin Flack: Nitroly Lecture—Respiratory Efficiency in Relation to Health and Disease.

ROYAL COLLEGE OF SURGEONS, Lincoln's Inn Fields, W.C.—Mon., 4 p.m., Hunterian Oration by Sir Charters J. Symonds, K.B.E., C.B.; Wed., 5 p.m., Arris and Gale Lecture by Dr. F. W. Edridge-Green, C.B.E.: Cause and Prevention of Myopia.

ROYAL SOCIETY OF MEDICINE.—General meeting of Fellows, Tues., 5 p.m., *War Section*: Mon., 5 p.m., Exhibition and Demonstration of Splints etc., by Major M. Sinclair; 9 p.m., Paper with illustrative slides by Major Sinclair. *Section of Therapeutics and Pharmacology*: Tues., 4.30 p.m., Dr. J. H. Burn: Physiological Comparison of Digitalis Tinctures: Oral Administration of Pituitary Extract (Experimental). Dr. P. Hannill; (Clinical) Dr. M. Donaldson. *Section of Pathology*: Tues., 8.30 p.m., Drs. Gye and Kettle: Passive Immunity in Tetanus; Dr. Mackenzie Wallis: Estimation of Sugar in Blood; Dr. A. E. Gow: Pancreatic Infarct and Fat Necrosis; Dr. T. H. G. Shore: Influenzal Meningitis of Spinal Cord, etc.; Dr. E. H. Kettle: Congenital Sacral Teratoma, etc. *Section of History of Medicine*: Wed., 5 p.m., *Section of Dermatology*: Thurs., 4.20 p.m., Cases. *Section of Ology*: Fri., 4.45 p.m., Cases; 5 p.m., Dr. A. R. Friel: Zinc Ionization and Electrolysis in Chronic Otorrhoea. *Section of Electro-Therapeutics*: Fri., 8.30 p.m., Social evening, Informal discussion on questions of interest affecting the Section.

ROYAL SOCIETY OF TROPICAL MEDICINE AND HYGIENE, 11, Chandos Street, W.1.—Fri., 7.45 p.m., Microscopical Specimens; 8.15 p.m., Papers:—Lieut.-Col. J. O. Kennedy, R.A.M.C.: Pathology of Relapsing Fever; Dr. A. M. Cole: Five Cases of Sarcosis Infection; Dr. A. Connall, W.A.M.S.: Examination of Chrysopeps for Filaria in West Africa.

POST-GRADUATE COURSES AND LECTURES.

GLASGOW POST-GRADUATE MEDICAL ASSOCIATION, Royal Hospital for Sick Children.—Wed., 4.15 p.m., Mr. A. MacLennan and Mr. W. Rankin: Surgical Cases.

HOSPITAL FOR SICK CHILDREN, Great Ormond Street, W.C.1.—Thurs., 4 p.m., Dr. Cockayne: Myopathy.

LONDON LOCK HOSPITALS.—Clinical Instruction daily. Lectures (Male Hospital, Dean Street, W.1.) Mon., 5 p.m., Mr. Gibbs: Ante-

natal and Post natal Treatment of Syphilis; Tues., 2.30 p.m., Mr. McDonagh: Laboratory Results and Clinical Experience; Wed., 4.30 p.m., Mr. Joly: Tests of Cure for Gonorrhoea; Fri., 4 p.m., Mr. Abraham: Early Syphilis Rashles.

MANCHESTER BARRIES' HOSPITAL.—Sat., 3.30 p.m., Dr. Renshaw: Congenital Syphilis.

MANCHESTER ROYAL INFIRMARY.—Tues., 4.30 p.m., Dr. F. E. Tylecote: Lumbar Puncture and its Value in Diagnosis.

NATIONAL HOSPITAL FOR DISEASES OF THE HEART, Westminster Street, W.1.—Mon., 5.30 p.m., Dr. Russell Wells: Irregular Heart Action.

NATIONAL HOSPITAL FOR THE PARALYSED AND EPILEPTIC, Queen Square, W.C.1.—Daily, excepting Wed. and Sat., 2 p.m., Out-patient Clinics. Lectures.—3.30 p.m., Mon., Dr. K. Wilson: Old and New Afferent Systems; Tues., 3.30 p.m., Dr. Collier: Acute Polyneuritis. Demonstrations of Cases.—3.30 p.m., Thurs., Dr. Taylor: Fri., Dr. Tooth.

NORTH-EAST LONDON POST-GRADUATE COLLEGE, Prince of Wales's General Hospital, Tottenham, N.15.—Daily, 2 p.m., In- and Out-patient Clinics, Operations, etc. Lecture Demonstrations:—Mon., 4.30 p.m., Mr. Tanner: Surgical Cases; Tues., 4.20 p.m., Dr. A. J. Whiting: Innocent Irregularities of the Heart; Wed., 3 p.m., Dr. Oliver: Skin Cases; Thurs., 3 p.m., Mr. Carson: Surgical Cases; Fri., 3 p.m., Mr. Benians: Diagnostic Clinical Pathology.

NORTH OF ENGLAND BRANCH, British Medical Association, Royal Victoria Infirmary, Newcastle-upon-Tyne.—Fri., 2.15 p.m., Mr. Grey Turner: Cancer of the Colon; 2.45 p.m., Dr. D. W. Patterson, O.B.E.: Diseases of the Bronchi; 3.15 p.m., Professor H. B. Angus: Splint Treatment of Fractures of the Upper Extremity; 3.45 p.m., Tea; 4 p.m., Dr. A. F. B. Shaw: Arterial Degeneration; 4.30 p.m., Mr. N. Hodgson: Compound Fractures.

SALFORD ROYAL HOSPITAL.—Thurs., 4.30 p.m., Mr. Smalley: Nasal Sinusitis.

ST. MARY'S HOSPITALS, Manchester, Whitworth Street West Branch.—Fri., 4.30 p.m., Mr. Morley: Acute Intestinal Obstruction in Infants.

WEST LONDON POST-GRADUATE COLLEGE, Hammersmith, W.—Daily, 10 a.m., Ward visits; 2 p.m., In- and Out-patient Clinics and Operations. Lectures.—5 p.m., Mon., Mr. Harman: Intestinal Sepsis and Irido-cyclitis; Tues., Dr. Morton: X-ray Appearances of Stomach Diseases; Wed., Dr. Owen: Gastric Disorders; Thurs., Dr. Bruce: X-ray Diagnosis of Joint Disease; Fri., Mr. Baldwin: Appendicitis.

British Medical Association.

OFFICES AND LIBRARY, 429, STRAND, LONDON, W.C.2.

Reference and Lending Library.

THE READING ROOM, in which books of reference, periodicals, and standard works can be consulted, is open to members from 10 a.m. to 6.30 p.m., Saturdays 10 to 2.

LENDING LIBRARY: Members are entitled to borrow books, including current medical works; they will be forwarded, if desired, on application to the Librarian, accompanied by 1s. for each volume for postage and packing.

Departments.

SUBSCRIPTIONS AND ADVERTISEMENTS (Financial Secretary and Business Manager, Telegrams: Articulate, Westrand, London).
MEDICAL SECRETARY (Telegram: Medisecra, Westrand, London).
EDITOR, *British Medical Journal* (Telegrams: Ailiology, Westrand, London).

Telephone number for all Departments: Gerrard 2630 (3 lines).

SCOTTISH MEDICAL SECRETARY: 6, Rutland Square, Edinburgh, (Telegrams: Associate, Edinburgh, Tel.: 4361 Central.)

IRISH MEDICAL SECRETARY: 16, South Frederick Street, Dublin, (Telegrams: Bacillus, Dublin, Tel.: 4737 Dublin.)

Diary of the Association.

FEbruary.

- 15 Tues. London: Scrutiny Subcommittee, 2 p.m., Willesden Division, St. Andrew's Parish Hall, High Road, Willesden Green, N.W., 8.30 p.m.
- 16 Wed. London: Council, 10 a.m., Chichester and Worthing Division, Steyne Hotel, Worthing, 6.39 p.m.; address by Dr. A. F. Harst on Asthma 6.45 p.m.
- 24 Thurs. London: Dominion Committee, 3 p.m.

APPOINTMENTS.

GRIFITH, Nora, B.A., M.B., B.Ch., B.A.O. Dub., Assistant Medical Officer of Health and School Medical Officer to Mountain Ash Education Committee, Glam.

MORLEY, John, Ch.M., F.R.C.S., Honorary Assistant Surgeon, Manchester Royal Infirmary.

STUART, F. J., O.B.E., M.R.C.S., L.R.C.P., Medical Superintendent, County Mental Hospital, Bury Wood, Northampton.

BIRTHS, MARRIAGES, AND DEATHS.

The charge for inserting announcements of Births, Marriages, and Deaths is 6s., which sum should be forwarded with the notice not later than the first post on Tuesday morning, in order to ensure insertion in the current issue.

BIRTHS.

DICK.—On February 6th, at Beaufort House, Grange Park, Ealing, the wife of Major A. M. Dick, F.R.C.S., 1 M.S., a daughter.

EAGER.—On February 6th, at Exminster, Devon, the wife of Richard Eager, O.B.E., M.D., of a son.

DEATHS.

BASSALL.—On January 31st, at The Dingle, Manor Road, Worthing, John Bassall, M.D., M.R.C.S., F.R.M.S., late of Northwick, Cheshire and Headingley House, Knutsford, aged 65 years.

SCOTT.—At "The Tower," Murrayfield, Edinburgh, on February 2nd, Sarah Jeffrey, wife of Dr. Joseph Scott, Teberau, Persia.

SUPPLEMENT

TO THE

BRITISH MEDICAL JOURNAL.

LONDON: SATURDAY, FEBRUARY 19TH, 1921.

CONTENTS.

	PAGE		PAGE
BRITISH MEDICAL ASSOCIATION.		ASSOCIATION NOTICES:	
CURRENT NOTES:		MOTIONS FOR ANNUAL REPRESENTATIVE MEETING, 1921 ...	44
MEMORANDUM ON INSURANCE MEDICAL RECORDS ...	41	ELECTION OF MEMBERS OF COUNCIL, 1921-22 ...	44
DANGEROUS DRUGS REGULATIONS ...	41	INSURANCE:	
UNEMPLOYMENT INSURANCE ACT ...	41	CORRESPONDENCE ...	41
HANDBOOK OF THE ASSOCIATION ...	41	LOCAL MEDICAL AND PANEL COMMITTEES ...	47
SCOTTISH COMMITTEE ...	42	NAVAL AND MILITARY APPOINTMENTS ...	47
THE REPORT OF THE DISTRIBUTION COMMITTEE ...	42	DIARY OF SOCIETIES AND LECTURES ...	48
LENDING LIBRARY ...	42	ASSOCIATION INTELLIGENCE ...	48
MEANS OF OBTAINING THE COLLECTIVE OPINION OF THE		DIARY OF THE ASSOCIATION ...	48
PROFESSION ON QUESTIONS OF POLICY:		APPOINTMENTS... ..	48
MEMORANDUM BY THE BRITISH MEDICAL ASSOCIATION ...	42	BIRTHS, MARRIAGES, AND DEATHS ...	48
MEETINGS OF BRANCHES AND DIVISIONS ...	43		

British Medical Association.

CURRENT NOTES.

Memorandum on Insurance Medical Records.

A MEMORANDUM on Medical Records (Document M. 29) divided into three parts—the first historical, the second instructional, and the third ethical—has been issued by the Insurance Acts Committee to all Panel and Local Medical Committees. It has been considered advisable to issue to every insurance practitioner the second and third parts of this Memorandum in order, on the one hand, that the duties of insurance practitioners in connexion with the keeping of record cards may be fully understood, and on the other that the true position with regard to the preservation of professional secrecy under the new system may be made clear to all concerned. The first part of the Memorandum, tracing the history of record cards from the inception of the Insurance Acts to the present date, may, however, be obtained by any practitioner on application to the Medical Secretary, 429, Strand, W.C.2.

Dangerous Drugs Regulations.

Last week's SUPPLEMENT contained the full text of the Memorandum on the draft Regulations under Section 7 of the Dangerous Drugs Act, 1920, which was forwarded on February 3rd, 1921, by the British Medical Association to the Home Secretary. The Regulations are for the control of all dealings in morphine, cocaine, ecgonine, diamorphine (heroin), and their respective salts, as well as in medicinal opium and any preparations containing not less than 0.2 per cent. of morphine, or 0.1 per cent. of cocaine, ecgonine, or diamorphine. It was recorded in last week's JOURNAL, p. 241, that the Permanent Under-Secretary of State in the Home Office, Sir Edward Troup, in a statement in the public press, had said among other things that a doctor will not have to enter the fact in a book whenever he gives a hypodermic injection of morphine or otherwise administers any of these drugs. Sir Edward Troup has since replied to the British Medical Association in a letter dated February 12th, written on behalf of the Home Secretary. The Secretary of State, he says, has very

carefully considered the representations submitted on behalf of the British Medical Association, and he thinks that it should be possible to meet most, if not all, of the points taken in the Association's memorandum. The Home Secretary suggests that in the first instance the Medical Secretary of the Association should discuss the various points with the representatives of the Home Office, and if after such discussion a deputation from the Association appears to be desirable, the Secretary of State will be very willing to receive one. On February 14th Dr. Alfred Cox, the Medical Secretary, had a conversation with Sir Malcolm Delevingne, an Assistant Secretary in the Home Office, who agreed to send his proposals in time for consideration by the Council of the Association at its meeting on February 16th.

Unemployment Insurance Act.

Two further decisions have been received from the Ministry of Labour in connexion with doctors' servants and the Unemployment Insurance Act (see SUPPLEMENT, January 22nd, 1921, p. 21). It should be borne in mind that exemption from the scope of the Act as regards domestic servants is governed by the following statement: "employed in domestic service except when the employed person is employed in any trade or business carried on for the purpose of gain." The Ministry's decisions are as follows: Contributions are payable in respect of a medicine boy and messenger and a coachman employed by a doctor. A covering letter states that these decisions will apply to persons employed in the same occupation under similar conditions, and that the decision regarding a doctor's coachman will apply in principle to chauffeurs employed by medical practitioners to drive them on their rounds to visit patients.

Handbook of the Association.

The question of the *Handbook* of the Association for 1921-22 will be under consideration by the Propaganda Subcommittee on or about March 16th. The Subcommittee would be grateful for any suggestions on the subject from Honorary Secretaries or other members interested. Copies of the current *Handbook* will, so far as possible, be sent to members who apply for them.

Scottish Committee.

The following, among other matters, were dealt with at a meeting of the Scottish Committee held on February 10th, 1921:

Report of Scottish Consultative Council.—It was decided to hold a meeting of Scottish representatives in May to consider the Report. A questionnaire is to be issued to Divisions on the recommendations contained in the Report; replies to be sent in before April 15th.

Scale of Fees to Practitioners under the Midwives (Scotland) Act.—No reply having been yet received from the Board of Health to the proposals put forward by the Committee, it was resolved to advise practitioners not to undertake to respond to the call of midwives until a satisfactory reply has been given by the Board.

Mileage Grant to Insurance Practitioners.—The Rural Practitioners Subcommittee reported that the grant for 1920 has now been distributed on the basis of the scheme agreed to by the Subcommittee. The total sum is £55,000, with an additional sum of £10,000 for areas of special difficulty. The object of the "grading" of the units in the scheme is to secure that quasi-rural practitioners shall not benefit unduly at the expense of the strictly rural practitioner, and that object seems to the Subcommittee to have been attained. Panel Committees, however, are requested to examine carefully the local distribution with this in view. It was noted by the Committee that the value of the "unit" is 1s. 8d. in Scotland, which is apparently less than in England, and the Subcommittee was requested to consider the matter.

Highlands and Islands Subcommittee.—The Subcommittee recorded its satisfaction that the Board of Health had agreed to their representations for an increase in the guaranteed minimum income in single-practice areas, and for an increase in the scale of fees chargeable to patients under the Board's scheme. It was resolved that the Board be urged to fulfil their promise to review the Highlands grant in the light of the alterations in the Lowlands mileage grant, and to base the case for increase on: (a) The fact of the specially arduous conditions in the Highlands, which are comparable, not with average Lowland rural areas, but with the areas of special difficulty to which the additional grant of £10,000 is applicable; (b) the fact that the Lowlands grant has been increased two and a half times; (c) the fact that the cost of motor travelling is still increasing.

The Report of the Distribution Committee.

The importance of this matter justifies a further allusion to this report, which was dealt with in the SUPPLEMENT of February 5th, p. 32. The concluding paragraph on the difficulties of obtaining returns of mileage refers to a subject on which the Insurance Acts Committee has made repeated appeals to those concerned. If those insurance practitioners for whom the mileage fund is provided and who are directly concerned in getting their proper share of this fund neglect to send in their returns, they must not be surprised if the result of the distribution is unsatisfactory to them.

To deal with another aspect of the work of the Distribution Committee, some public acknowledgement is due to the Chairman, Sir Woodburn Kirby, for his services to insurance practitioners. The medical members of the Committee and the departmental members are of course interested, each in different ways, in the money to be distributed. But the chairman has no interest beyond that of performing a public service, and Sir Woodburn Kirby, a busy and eminent accountant, has performed a real service to the medical profession in accepting a position which entails no small demand on his time and skill. He is connected by birth and by marriage with our profession, and it is pleasant to suppose that this may have had something to do with his willingness to accept and continue in the chair of the Committee.

Lending Library.

The Librarian will be glad to assist members of the Association in the selection of works to be sent them by post, in accordance with the arrangements for borrowing books that are notified each week on the last page of the SUPPLEMENT.

**THE MEANS OF OBTAINING THE COLLECTIVE
OPINION OF THE MEDICAL PROFESSION
ON QUESTIONS OF POLICY.**

The Minister of Health made a request to a deputation from the British Medical Association on November 1st, 1920, that he should be provided with a body really representative of the whole profession, which he could consult on questions of policy, instead of being approached by half a dozen bodies each claiming to represent the profession. The matter has since then received the active attention of the Council, and certain sectional medical organizations have been invited to co-operate with the Association in forming such a body.

The Federation of Medical and Allied Societies called a conference on February 1st, 1921, with a view to discussing co-operation on the lines suggested by the Minister of Health. It issued a statement in which it laid down its ideas of the qualifications of such a body. The British Medical Association, amongst other bodies, was invited to the conference, but declined because it was itself engaged, at the suggestion of the Minister of Health, in trying to constitute a central medical committee representative of the profession as a whole.

The following memorandum, stating the views of the Association on the qualifications of a body professing to represent the medical profession as a whole, has been sent to the Federation, to the bodies whose representatives signed the invitation to the February 1st conference, to those other bodies invited to the conference, and to the Minister of Health:

**MEMORANDUM OF THE BRITISH MEDICAL
ASSOCIATION.**

1. The Minister of Health, addressing a deputation from the British Medical Association on November 1st, 1920, complained of the number of bodies that approached him claiming to be representative of the profession, and asked that some one body recognised as representing the whole profession should be provided, so that he could consult it on matters of policy affecting the medical profession. Further, in a letter to the Chairman of Council of the Association, dated November 26th, 1920, the Minister said he was "satisfied that it would be impossible to secure the constitution of a representative body without the good offices of the B.M.A. in bringing them together," and went on to suggest that the Council of the Association "should now initiate action to secure the appointment of a body whose credentials will be incontestable."

2. The Association has accepted the Minister's suggestion, and has invited certain medical bodies to co-operate with it in constituting a body which will satisfy his requirements. The Association desires to state its views as to the qualifications of such a body.

**Qualifications of a Body Representing the Medical
Profession as a Whole.**

3. In the first place the body must represent the views of the medical profession *and the medical profession alone*. The Minister has asked for such a body. When he wishes for the views of the Dental, Pharmaceutical or Nursing professions, he will naturally call on the organisations which represent those professions. They would not desire to have their views confused with those of the medical profession, and the medical profession would certainly not consider that representations from any body which attempted to fuse the interests and views of widely differing bodies ought to be taken by the Minister as the considered policy of the medical profession.

4. The body must be an immediately and directly *responsible* body—that is to say it must recognise the authority of its constituents and no other authority. It must be under the constitutional control of the whole of its constituents and without undue bias toward any one section of them. A body which the bulk of the profession felt they had no direct means of controlling would be worse than useless for the purpose of the Minister, and might do great damage to the interests of the profession itself.

5. The body must therefore be really *representative*. That is to say it must have modern constitutional methods of ascertaining the opinion of its constituents

and of securing their acceptance of agreements made on their behalf. The body as a whole, or the constituent parts of the body, must therefore have machinery, both central and local, for the purpose of eliciting opinions on policy.

6. The constituents of the body must be directly and intimately concerned in what is generally known as "medical politics," and they must be trained in expressing opinions on such matters. Bodies exclusively or mainly scientific have no concern with medical politics and have not the machinery for dealing with such matters.

7. The body must not profess to promote the interests of the community rather than those of doctors. Such a body would not be recognised by doctors as the body which primarily represents them and their views. Doctors are citizens as well as doctors, but what the Minister is understood to require is a body which will tell him what doctors *qua* doctors think, whether as to the interests of their own profession or as to general questions of public health.

How far does the British Medical Association meet these Requirements?

8. The British Medical Association acting alone would be justified in claiming that it possesses the qualifications enumerated above. It contains 52 per cent. of the whole profession on the Register, and this percentage applies approximately to every section of the profession. If those who are not practising their profession, and what may be called the "floating medical population" be eliminated, the Association could be shown to include about 60 per cent. of the active members of the profession.

9. It is really representative of its members and has well-tried machinery, both local and central for ascertaining their views. The control of its members over the Association is thoroughly democratic and complete. Its members are trained, both locally and centrally, in dealing with medical politics. It does not profess to represent the views of other professions, but it does claim to know with greater certainty than any other body the opinions of the majority of the medical profession.

10. Moreover, the Association is recognised informally by large numbers of practitioners who do not belong to it as the body which voices the wishes and sentiments of the profession as a whole. It is very frequently consulted by non-members individually in their troubles; also by bodies of non-members, or bodies of local practitioners, some members some not. It is recognised by the public as the body which bears the same relation to doctors generally as, for example, the National Union of Teachers does to elementary teachers, or the Miners' Federation to miners. The Government has frequently made use of it as the body which can more adequately than any other body represent the general profession. To name only the most recent and most conspicuous example—the machinery of the Association, both central and local, was used by the Government for the purpose of providing doctors for the services with due regard to the interests of the civil population. The Government recognised that there was no other existing body which had the machinery, and there was no question about the Association's ability to deal with and represent the views of practitioners, whether members of the Association or not.

11. The Association does not profess to include every member of the medical profession, and it knows of no organisation of any other calling which can make such a claim. The Association does claim to be by far the largest body of organised medical practitioners with a machinery capable of eliciting, by recognised constitutional methods, the views of the organised profession.

Co-operation of the British Medical Association with other Organized Medical Bodies.

12. In order to make itself as useful as possible to all sections of the profession the Association has always tried to work with organised bodies representing distinct sections of the profession. Representatives of the Society of Medical Officers of Health, the Medical Women's Federation, the Poor Law Medical Officers' Association of England and Wales, the Medico-Psychological Association, the Association of Certifying Factory Surgeons, and other bodies have frequently sat on Committees of the Association. All these Societies have on occasion attended on deputations to Ministers arranged by the Association. Most of them regularly and closely co-operate with the Association in its work for the pro-

fession. The three first-named societies have standing representation on some of the most important Committees of the Association.

13. The Insurance Acts Committee of the Association in a very special way represents the interests of the (approximately) 14,000 practitioners engaged in National Health Insurance work. A majority of the Committee consists of members elected directly by the Local Medical and Panel Committees of the country with no restriction as to whether their nominees are members of the Association or not. The Committee is directly authorised by a representative Conference, acting on behalf of the Local Medical and Panel Committees, to carry out all negotiations with the Ministry of Health on matters affecting practitioners engaged in National Health Insurance work.

14. Though the constitution of the Association and its traditional and regular co-operation with bodies representing special sections of the profession would justify it in claiming the qualifications required by a body representing the profession generally, it has invited these other bodies as independent organisations to join with it in attempting to form the body suggested by the Minister of Health.

15. The Association therefore feels that in accepting Dr. Addison's suggestion, if, as it expects, it secures the co-operation of the medical societies above named, it will be able to offer the Minister a body which (with the exception next to be mentioned) is *really* representative of all the organised medical profession, both generally and sectionally. The body when formed would, of course, consult with other medical bodies not directly represented on it when such consultation was thought desirable or necessary.

16. The exception referred to is that of the Royal College of Physicians of London and the Royal College of Surgeons of England. The Association recognises that the Councils of these bodies are able to speak for the consultant section of the profession in a way which is not open even to the British Medical Association which includes a large number of the Fellows of the Colleges. The Association has intimated to the Royal Colleges that their co-operation in the matter now under consideration would be greatly valued and that after the adhesion of the other bodies referred to has been obtained the Royal Colleges will be approached again more formally.

Meetings of Branches and Divisions.

ULSTER BRANCH.

Dangerous Drugs Regulations.

THE Ulster Branch has passed the following resolution:

That the Ulster Branch of the British Medical Association, at its meeting in Belfast on February 10th, 1921, protests strongly against the action of the Home Secretary in having issued Regulations under the Dangerous Drugs Act imposing severe and impracticable restrictions on doctors in connexion with such drugs as cocaine, egonine, heroin, and medicinal opium, without any consultation with the British Medical Association.

That while anxious to help to suppress the use of habit-forming drugs the profession is against action which is not based on a knowledge of the customs of the profession as ascertained by consultation with its organization.

That a copy of this resolution be sent to the Home Secretary, the Chief Secretary, and to each of the members of Parliament for the Ulster constituencies.

METROPOLITAN COUNTIES BRANCH: CAMBERWELL DIVISION.

At a meeting of the Executive Committee of the Camberwell Division the Dangerous Drugs Act was considered, and it was resolved:

That the Executive Committee of the Division be applied to the Home Secretary, and be desired that they are impracticable that we must adhere to every clause of it.

A copy of the resolution was directed to be sent to the Home Secretary, the members of Parliament for the Division, the British Medical Association, and the medical press.

METROPOLITAN COUNTIES BRANCH: LEWISHAM DIVISION.

A MEETING of the Lewisham Division was held on February 4th, when the organization and ethical rules were adopted. The following officers were elected:

Chairman. Dr. G. W. Charsley. *Vice-Chairman.* Dr. Thomas E. White. *Representative on Branch Council.* Dr. James Gilchrist. *Honorary Secretary.* Dr. C. J. B. Buchan.

The Honorary Secretary reported that he had written to the Home Secretary about the draft Regulations under the Dangerous Drugs Act; it was decided that each member present should write also.

NORTH OF ENGLAND BRANCH: CLEVELAND DIVISION.

A BUSINESS meeting was held in the Zetland Hotel, Saltburn, on January 27th, when Dr. W. A. STEPHEN (Loftus) occupied the chair. The financial statement for 1920 was approved. It was resolved that the minimum fees to be charged to police authorities by members of the Division for professional attendance at the request of the police be half a guinea between the hours of 8 a.m. and 8 p.m., and one guinea between 8 p.m. and 8 a.m., and that such request be in writing. The Secretary was instructed to convey the resolution to the local authorities concerned. It was agreed to continue for 1921 the half-crown voluntary subscription for payment of Division expenses not defrayed by the head office.

The annual dinner was held in the Zetland Hotel, Saltburn, on February 3rd, when fifty-six members and friends were present, under the presidency of Dr. W. A. STEPHEN. A most enjoyable and successful evening was spent. Dr. T. M. BODY proposed the toast of "The Industries of Cleveland," which was suitably replied to by Sir ALFRED HUTCHINSON. The toast of "The Cleveland Division of the British Medical Association" was given by Mr. W. EDWARDS, M.A., in a humorous speech. The CHAIRMAN, in his reply, said that the Division was full of life and embraced in its ranks all the specialists in the area, as well as the vast majority of the general practitioners. He was particularly glad to see the close intercourse between the members of the country and Middlesbrough sections. "Sister Professions" was proposed by Dr. J. A. LONGLEY and responded to by Rev. H. HUBBARD, D.S.O., and by Mr. GEORGE BARNLEY, solicitor. "The Guests," proposed by Dr. A. BRYANS, was replied to by Mr. E. SPENCE, Deputy Mayor of Middlesbrough, and Mr. T. W. RIDLEY.

NORTH OF ENGLAND BRANCH: SUNDERLAND DIVISION.

The annual meeting of the Sunderland Division was held on February 1st, when Dr. R. G. BELL was in the chair. The annual report and financial statement was presented.

The following officers were elected for the coming year:

Chairman: Dr. R. G. Bell. Vice-Chairman: Dr. Chalmers.
Honorary Secretary and Treasurer: Dr. H. Boyd Cunningham.

UGANDA BRANCH.

A MEETING of the Uganda Branch was held at Entebbe on November 24th, 1920, when the President, Dr. A. R. COOK, was in the chair.

A unanimous vote of thanks was accorded to Dr. J. H. REFOR for his services as honorary secretary of the Branch, on his resignation of the office, and his appointment as Representative in the Representative Body for 1921-22 was confirmed.

In view of the Colonial Office reference to private practice in its terms of appointment the whole question was discussed, and it was unanimously resolved:

That the Colonial Office be asked to inform all applicants for medical appointments in Uganda that at present in most stations in the Protectorate the income from private practice was practically nil.

It was unanimously agreed that the Secretary of State's ruling, that one-half of the M.O.H. allowance should be granted to medical officers and senior medical officers who enjoy the privilege of private practice, be accepted.

It was resolved to resume scientific discussions at the forthcoming general meetings, and Major Wiggins, P.M.O., promised to open a discussion on blackwater fever at the meeting in January.

The scheme of temporary medical officers' appointments was discussed. It was decided to forward recommendations to the Colonial Office through the Governor, and also to express regret that the medical staff of the Protectorate was not larger than it was in January last, and to suggest that the immediate introduction of the West Coast scheme of pay and allowances, present and prospective, was absolutely essential for the welfare of the Protectorate.

The P.M.O. reported that the Governor had agreed with the opinion that medical women and Sinhalese doctors were both unsuitable for filling vacancies on the staff on account of the conditions of the country.

Association Notices.

MOTIONS FOR ANNUAL REPRESENTATIVE MEETING, NEWCASTLE, JULY, 1921.

NOTICES OF MOTION by Divisions, Constituencies, or Branches, for the consideration of the Annual Representative Meeting of the Association, commencing Friday, July 15th, 1921, proposing to make any addition to, or any amendment, alteration, or repeal of, any Article or By-law, or to make any new Article or By-law, or proposing material alteration of the policy of the Association in matters relating to the honour and interests of the profession or of the Association, must be published in the

BRITISH MEDICAL JOURNAL SUPPLEMENT not later than May 14th, and for this purpose should be received by the Medical Secretary not later than April 30th.

ELECTION OF MEMBERS OF COUNCIL FOR 1921-22 BY BRANCHES OUTSIDE THE UNITED KINGDOM.

THE following being the only nominations received for election to the Council for 1921-22 by Branches outside the United Kingdom (February 12th was the last day for receipt of nominations) are elected Members of Council for the periods stated:

No Nomination. South Australian, Tasmanian, Victorian, and Western Australian Branches.

Dr. H. A. FRANCIS (for two years 1921-23). New South Wales and Queensland Branches.

Dr. DAVID EWART (elected in 1920-21 for three years). New Zealand Branch.

No Nomination. Barbados, Bermuda, British Guiana, Grenada, Halifax (Nova Scotia), Jamaica, Leeward Islands, Montreal, St. John (New Brunswick), Saskatchewan, Toronto, Trinidad and Tobago Branches.

Lieut.-Colonel R. H. ELLIOT, I.M.S. (ret.). Assam, Baluchistan, Bombay, Burma, Ceylon, Hyderabad and Central Provinces, Punjab, South Indian and Madras Branches.

No Nomination. Hong Kong and China, Malaya Branches.

Dr. T. D. GREENLEES. Border (South Africa), Cape of Good Hope (Eastern), Cape of Good Hope (Western), East Africa, Egyptian, Gibraltar, Griqualand West, Malta, Natal Coastal, Natal Inland, Nyasaland, Orange Free State and Basutoland, Pretoria, Rhodesia, Uganda, Witwatersrand Branches.*

* Lieut.-Colonel Ward, C.B.E., D.S.O., was also nominated for this group, but has stated that he will be unable to give the time necessary, and so will not seek election.

BRANCH AND DIVISION MEETINGS TO BE HELD.

EDINBURGH BRANCH.—The winter clinical meeting of the Edinburgh Branch will be held in the Royal Infirmary on Friday, March 4th. All members of the profession are cordially invited. The museum will be open from 11 a.m. Arrangements will be made for holding special clinics during the forenoon. The clinical meeting will be held at 3.15 p.m. Those who have patients, specimens, etc., to show are requested to communicate with Dr. John Eason, 35, Melville Street, or Mr. J. W. Struthers, 15, Ainslie Place, not later than February 20th. At 5 p.m. Dr. J. S. Haldane, LL.D., F.R.S., Oxford, will deliver a lecture on "Some recent advances in the physiology of respiration, circulation, and renal excretion." There will be dinner at 6.30 p.m. in the Caledonian Station Hotel; morning dress; dinner ticket, price 10s. 6d. Members of the Branch are requested to notify the Honorary Secretaries not later than February 28th whether or not they intend to be present.

METROPOLITAN COUNTIES BRANCH: CAMBERWELL DIVISION.—A meeting of the Camberwell Division will be held on Wednesday, March 2nd, when Dr. H. C. Cameron, of Guy's Hospital, will give an address on Children.

WORCESTERSHIRE AND HEREFORDSHIRE BRANCH.—The spring meeting of this Branch will be held at Ledbury on Thursday, April 14th, when a British Medical Association Lecture will be given by Mr. P. L. Daniel, F.R.C.S., on "The differential diagnosis of acute abdominal conditions."

INSURANCE.

CORRESPONDENCE.

The New System of Medical Records.

SIR,—The letter from Sir William Hodgson on this subject, traversing the Memorandum issued by the Insurance Acts Committee, and condemning at some length and somewhat illogically, if I may say so, the whole system, demands a reply.

The Conference of Local Medical and Panel Committees held last October instructed its executive body—the Insurance Acts Committee—of which Sir William is a member, to hold its hand, neither condemning nor approving until sufficient time had elapsed to allow a considered judgement to be given, and a month seems hardly long enough for that purpose.

The first part of the Memorandum makes it quite clear that the keeping of records was part of the bargain made with the Government in 1912, and was and has been paid for as such ever since. That the obligations, but not the payment, was suspended for four years during great national stress does not affect the fact, but rather the reverse.

Granted that a record must be kept—and this was accepted by the conference—the only question that can arise is as to the form which it should take. It had to be "simple and not involving a multiplicity of forms." The great objection to the old form of record was that any

value to the practitioner or his patient was lost by its having to be surrendered at the end of each year, whereby the whole of his more or less valuable clinical notes was lost, and he had to begin all over again entering names and addresses, etc.

The new record card certainly has several advantages—it is a continuous record; the name, address, and other particulars are entered on it once and for all before it comes into the practitioner's possession; and it acts as an index register of his panel.

With a fairly extensive experience of recording illnesses, both privately and in the out-patient department of a large hospital, I have yet to see a more simple form of record card than the one recently evolved by the Inter-departmental Committee. If Sir William Hodgson (or anyone else) would bring his great talents to bear on evolving a more simple and at the same time useful card, no one, I venture to say, would more cordially welcome it than his colleagues of the Insurance Acts Committee.

Sir William Hodgson was scarcely happy in his quotation from Kipling and the deduction he drew from it. The "colonel's lady" without doubt has all her ailments duly "labelled, ticketed, and docketed" in the case-book of her family doctor, while it is the "Judy O'Grady—her sister under the skin"—who has not up to the present had that advantage. Now the Government steps in and says Judy shall be placed medically on a par with her more fortunate sister. Does any thinking man with the welfare of his profession and patients at heart deny the wisdom of this, or the right of the Ministry to see that it is done?

Similarly with the peer and the pauper, each has his health sheet kept either in the consulting-room of his doctor or in the archives of a board of guardians. The peer takes good care to consult a doctor who keeps records; he wants no haphazard physician with placebos. This leads up to the question of secrecy and how far this cry is genuine. It seems to me the question hardly comes in if the doctor keeps his own records. Does Sir William Hodgson or those who think with him refrain from sending cases of venereal disease and all its sequelae to the best general hospital, where all the details are noted and may be seen by both nurses and attendants? Did he in the old club days refuse to accept clubs which required certificates of sickness? If not, for ever let him hold his pen on this subject.

Much has been made of the time wasted in keeping records. Of course it takes a little time—very little when one is used to it—but in my experience the time is more than saved on some future occasion. The obligation is to keep only such notes of every case treated as in the opinion of the practitioner are likely to be of value to himself or any other practitioner treating the patient subsequently. The discretion is left to the practitioner's own judgement. Is it much trouble to enter the letter "D." in case of digestive disturbances or the letters "R.C." in minor respiratory troubles? These or similar symbols are all that need or are expected to be entered in "trivial" cases. But where does trivial end and serious begin? The "R.C." may become tuberculosis of the lung, the vague "D." may become carcinoma of the stomach, the septic mouth may infect the heart valves, or the neurasthenia may become the G.P.I. Let us then make some note, however brief, so that we may learn—those of us at any rate who do not know it all. Also let us keep an accurate summary of all attendances, otherwise when the economy campaign reaches the capitation fee, our negotiators may be "in the soup."

As regards inspection by the Regional Medical Officers, I can only say that I have been assured by the courteous gentleman who has charge of this region that his final instructions from the Ministry were something as follows: "You are a panel doctor going to help with your knowledge and experience other panel doctors, and by so much as you cease to be a panel doctor and become an official by that much will you have failed in your duty." If that is so, why should we call "Wolf" when there is no wolf but only a courteous colleague?

In conclusion I would say—and in this I feel sure Sir William Hodgson will agree—that a more earnest, zealous, or hard working body of men than the Insurance Acts Committee it would be difficult to find, and that any real criticisms of this system, or anything else connected with the working of the Acts, will always be welcomed with both hands.—I am, etc.,

Sheffield, Feb. 14th.

ALEX. FORBES.

Insurance Medical Records.

SIR,—We are pledged to make an honest attempt to keep the new record cards, but have reserved to ourselves the right of criticism in the light of experience. I believe

that many of our anticipated difficulties, whether they be realized or not, can be traced to the fundamental error of attempting to combine for our insured patients visiting lists, daybooks, and clinical life-histories all on one card—a combination never attempted for our private patients.

When the time comes to revise the present Regulations I would like panel practitioners and Panel Committees to consider seriously the following suggestions:

Let the present envelopes remain as index cards and clinical life-histories of our insured patients.

Let the only obligation on the part of the general practitioner, after verifying the correctness of certain particulars, be to enter on these envelopes such clinical notes as he may consider of value either to himself or to succeeding medical practitioners.

Let the law of averages be applied to assist us in obtaining the necessary statistics of attendances and visits, as is being done at the present time in the ease of the mileage returns.

Let it be the duty of Panel Committees to find a certain percentage (say 10 per cent.) of practitioners with average practices who would undertake to keep a simple form of loose-leaved daybook for their insured patients, providing either a fortnightly or monthly return of all attendances and visits, these returns, when completed, to be forwarded to the regional referee's office, there to be tabulated.

Let some suitable remuneration be granted from the local medical pool to these public-spirited gentlemen for their labours on behalf of the rest of the profession.

From these compact reliable returns the average number of attendances and visits per insured person for the area could easily be calculated.

Result.—(1) Relief to 90 per cent. of practitioners of much irksome and tiresome work. (2) Less wear and tear of envelopes. (3) Less continuation cards required, and so less bulk. (4) More efficient clinical records: attention directed solely to making them of real value. (5) A compact reliable and easily digested set of statistics in place of a mass of unreliable figures difficult to collect or tabulate. (6) Less local inspection: statistics of attendances and visits would be worked out in regional offices.

Arguments can be adduced both for and against this proposal, but I believe those in favour far outweigh those against, and I ask panel practitioners to give it their serious consideration; it would make for simplicity, efficiency, and reduction of labour.—I am, etc.,

Bratton, Wilts, Feb. 13th.

T. WOOD LOCKET.

Note.—The germ of this suggestion appeared in the second part of an amendment placed on the agenda of the last Panel Conference by Warrington.—T.W.L.

The New Record Cards.

SIR.—I am instructed to forward to you the following resolution which was passed at a meeting of the Kingston-upon-Hull Panel and Local Medical Committee held on February 4th, 1921:

This Committee, having carefully considered the question of the new medical Record Cards and the agitation which has been fomented against them in the public press, and having heard the views of their members who have had five weeks' experience of the working of the system, desires to record its opinion that:

1. The outcry which has taken place against the Records in some press organs is quite unwarranted, probably promoted for interested reasons, and not likely to conduce either to the safety and welfare of panel patients or to the smooth and efficient working of the National Health Insurance Acts.

2. While the system is doubtless capable of improvement in some of its details, it embodies a sound and necessary principle, and, if honestly and thoroughly administered, is calculated to be of great future benefit alike to patients, doctors, and the Ministry of Health.

3. As at the Conference of Local Medical and Panel Committees, held in London on October 21st, 1920, the scheme was discussed, and it was resolved that a fair trial should be given to the new Record Cards; that decision should be loyally accepted and adhered to for at least one year, during which time efforts could be made to collate the experiences of committees and doctors throughout the country with a view to improving some of the details of the present scheme and eliminating any features which may be found to interfere with its usefulness or efficiency.

—I am, etc.,

JOS. NELSON,

Honorary Secretary.

Hull, Feb. 14th.

SIR,—May I be allowed to state that my partners and I have found that the new medical record cards entail very little extra work and we entirely approve of them.

Between us we have a panel of over 2,500. We have placed all our record cards together in cabinets in the

surgery, and find that it is a matter of only a few seconds to ask a patient to produce his or her card, find it in the cabinets, and make the required entries. It is true that clerical errors are prominent in the cards as issued, and we have found that a number of cards are missing. These are easily replaced by continuation cards. The new cards are only a month old, but we, at any rate, have "got to work" with them.

Not one of our patients has raised any objection on seeing entries made on their cards. At first we were considerably puzzled as to how to proceed on receipt of the new cards, which all arrived together, but a month's trial of them has shown that we were hasty in raising objections.

The point as to whether it is necessary to record every attendance, visit, and certificate has still to be settled. I refuse to believe that such details are required just to show whether we are earning our money. The cards are on trial, and will no doubt be amended in some way. I consider that it is very necessary to keep records of all patients, and shall be just as pleased to receive records of those who are troublesome and worry one with nothing wrong as I shall be to receive records of interesting cases.

As far as I can in the rush of work I intend to keep the records to the best of my ability, and I hope others will do the same. I am, etc.,

Uxbridge, Feb. 3rd.

H. VICKERS, M.R.C.S., L.R.C.P.

Medical Records.

SIR,—A letter from Sir W. Hodgson in the SUPPLEMENT of February 12th seems to require some reply lest panel practitioners may be misled as to the duties imposed upon them in connexion with the new record cards.

The obligation of panel practitioners in the matter are clearly laid down in the report of the Records Committee and in the instructions issued by Insurance Committees with the cards. It is not correct to state that all certificates must be entered on the card. Only first and final certificates are required.

It is not correct to state that all ailments of every kind are to be entered on the records. With regard to clinical notes and diagnosis there is no obligation to make any entry on any particular case, but the doctor must make such entries as he considers will be of value to himself, or any doctor coming after, in the treatment of the patient. A series of symbols is suggested for the recording of minor ailments should the doctor consider it necessary to enter them.

It is required that all attendances and visits are to be entered, and arrangements are provided for summarizing visits each week or month, as well as attendances where these are very frequent.

The Records Committee considered the "professional secrecy" question, and were satisfied that the arrangements they suggested and which have been set up will provide efficiently against leakage of professional information during transit from doctor to doctor.

As Sir W. Hodgson says, the system is on trial, and if he or anyone else, will devise a more simple system which would be useful and helpful as between practitioner and practitioner in the interests of patients, or, after experience, offer constructive criticisms of this system, the Insurance Acts Committee will welcome them. At the same time I would suggest that those who squeal that the shoes pinch before they have had time to try them on, are never likely to find out where they really do pinch, or to get a comfortable working fit.—I am, etc.,

Birmingham, Feb. 15th.

H. GUY DAIN.

Medical Records in Scotland.

SIR,—The insurance practitioner of to-day is required in Scotland to "furnish" records, and, according to the Scottish Board of Health, in England merely to "keep" records. The Scottish Board have omitted from their Regulations two essential words "and deliver." To establish the contention of the Board—that there is a definite obligation on Scottish panel practitioners to send their records to Insurance Committees—the Regulation should read "furnish and deliver." No travesty of the English language can clothe the word "furnish" with a meaning it has not got. If I ask a firm to furnish me with suitable appliances for filing the record cards it will do so; the delivery of the goods is another matter. I shall have to pay carriage. It would, therefore, appear that the Scottish Board are not in any essential point in advance of the English Board, and it becomes a matter for arbitration as to whether the cards are to be delivered by the practitioner or, alternatively, collected by the Board: in addition I submit that if kept and available for inspection in my consulting room I have furnished records and complied with the spirit and letter of Clause 8 (11) Terms of Service

for Practitioners, etc. Obviously records "furnished" may be delivered by the practitioner, collected by the Board, or available for inspection.

Scottish practitioners would do well to note the letter of the Scottish Board as published in the SUPPLEMENT of February 5th, 1921. No doubt we will in time receive many official documents with a quasi-judicial tone, entirely cold and unsympathetic towards the rural practitioner, indicating that the Scottish Board are drifting towards a policy of trying to enforce the record card regulations according to their own interpretation, and riding rough-shod over the practitioner. It is essential that we should as one man follow the recommendations of the Scottish Insurance Acts Subcommittee, and not transmit records to Insurance Committees until arrangements are made for reimbursement of expenses incurred.

Record keeping should not have begun until all the essentials were in the hands of practitioners. We are temporizing in Scotland until the arrival of the envelope. The scheme of the Interdepartmental Committee has begun in chaos, and is apparently in danger of ending in confusion.

We are told that the records "are designed to afford a continuous record of illness and incapacity." What about age, occupation, and, in the case of women, whether married, single, or widow, with date of such marriage or widowhood? Surely secretaries of approved societies are in a better position than practitioners to supply the details, which do not seem to be connected with a "continuous record of illness and incapacity."

It is quite obvious from the correspondence in the SUPPLEMENT and notices in the lay press that there is a wide divergence of opinion on the question of medical records. As regards the value of purely clinical records there can be no doubt in the mind of any experienced practitioner. We must remember, however, that this is just the beginning: an enlightened Board of Health will at an early date consider the question of embodying the records of welfare and health visitors and records of medical inspectors of school children, so that the logical ideal will be attained, and the envelope of each insured person will contain a continuous record of health, illness, and incapacity from the cradle to the grave.—I am, etc.,

Dumfries, Feb. 12th.

GEORGE R. LIVINGSTON.

Dangerous Drugs Regulations.

SIR,—The Medical Benefit Subcommittee of the Brighton Insurance Committee have had before them, and have very carefully considered, the provisions of the draft Regulations proposed to be issued by the Secretary of State for Home Affairs under the Dangerous Drugs Act, 1920. As a result of this consideration the Subcommittee passed the following resolutions:

1. That the Secretary of State for Home Affairs be informed that the procedure which it is required, in compliance with the proposed Regulations, that insurance practitioners should adopt, will prove, under the unnecessary official interference with everyday practice, so irksome to practitioners that it will be detrimental to the interests of the injured person inasmuch as the consequence will be, in many cases, to deprive the insured person of the drug which may be necessary, and which would otherwise be given, and further if such drug is prescribed, its required advertisement on the bottle or package will have a harmful effect on the patient in many cases.
2. That the insurance practitioner should be allowed, as heretofore, every latitude in determining the drugs considered most desirable for his insurance patient without having to disclose to lay inspecting officials professional matters, and should be responsible to the Minister of Health alone for his actions in this direction.

In the discussion which took place the main points which were emphasized are as follows:

"Article 8 (8) of the terms of service for insurance practitioners stipulates: 'A practitioner is required to supply to a patient where requisite drugs and appliances, which are necessarily or ordinarily administered by a practitioner in person, or are needed for immediate administration or application or needed for use before a supply can conveniently be obtained otherwise under the Regulations.'"

It would appear from the rather vague terms of the draft Regulations, that on every occasion upon which an insurance practitioner is under the necessity of complying with the obligations undertaken as a consequence of the foregoing article, he must make, or cause to be made, in a book kept for the purpose, specific and detailed, and indeed somewhat laboured entries, if the particular drug comes within the scope of these proposed Regulations. It is strongly felt that this will be detrimental to the interests of insured persons, inasmuch as the practitioner rather than comply with the necessary clerical procedure may

refrain from giving the necessary drug. I am aware that Sir Edward Troup, Permanent Under-Secretary at the Home Office, in a letter which appeared in the *Times* of February 9th, stated as follows:

"In several important respects the Draft Regulations have been misunderstood. It has been suggested, for instance, that a doctor is required on each occasion on which he gives a hypodermic injection of morphia, or otherwise administers any of the drugs, to enter the fact in a book. This is not so. The Regulations require certain records to be kept in cases where drugs are supplied, and these apply to doctors who supply medicines to their patients, as well as to chemists who supply them on a doctor's prescription. But there is no requirement that a record has to be kept of a personal administration of the drugs by a doctor."

If Sir Edward Troup's interpretation on this point is the correct one, then it is respectfully submitted that the draft Regulations should be so amended as to make the matter quite clear.

Provided an insurance practitioner has occasion to prescribe medicines containing an amount beyond the statutory limit of any of the drugs set forth in the proposed Regulations, then the fact must be advertised on the bottle or package containing such drugs. Indeed, the article defining the "application" of the Regulations in connexion with morphine, cocaine, egonine, and diamorphine, when read in conjunction with Article (8) of the Regulations, is rather confusing. However, it is suggested that a bottle or package loudly proclaiming to the insured person the fact that it contains a certain percentage of a dangerous drug is not conducive to that serene frame of mind which, in the interests of the patient himself, his medical attendant would wish him to cultivate.

It is hoped that your influential journal will see its way to support the views above expressed and make every endeavour to get the proposed Regulations so amended as to entirely safeguard the interests of the country's insured population.—I am, etc.,

JNO. CAMPBELL,

Acting Clerk to the Insurance Committee for the
Borough of Brighton.

February 11th.

Medical Benefit.

SIR, I agree with everything in the letter you publish from Dr. Eates, of the London Panel, under date January 15th, sent to the Minister of Health. I believe every panel practitioner in the country could tell the same tale of insured persons being removed from his list through errors either of the Insurance Committees, the approved societies, or both. People are removed, and when the doctor tells them they can no longer be attended as panel patients they are surprised—they say they are stamping their cards, and produce them for us to see. They urge there is a mistake, and very often there is. I have been told officially that it is the doctor's duty to satisfy himself that a person is entitled to benefit. Why the doctor? To do this involves a weary correspondence with the Insurance Committee and the approved society, and very few men have the time to do it—they simply "let things go." It does not so much matter for a townsman with a large panel, but the country doctor, with a small panel and most of his patients many miles away, loses not only his capitation fees but his mileage.

Like Dr. Eates, I consider that our record cards supplied under the new Regulations are "wofully incomplete," and the reason given by the Northumberland Insurance Committee is that the supplies have run short at the Ministry of Health.

I hold that when an insured person is removed from a doctor's list, he should be told at the time in plain language which he can understand that until he is restored to that list he must pay for his medical attention. The term "ceased to be insured" is too vague, and it should be explained why he has "ceased to be insured." I often get such a removal notice, and I know the person is in regular insurable employment, but unless I give myself infinite trouble writing letters and making inquiries I never find out, and then I hear it was all a mistake, after losing possibly several quarters' fees. Why should we be penalized through the mistakes of others? I have long pointed out that all the penalizing falls on the doctor and never on the Insurance Committee, the approved society, nor the insured person. We not only have our own clerical work to do, but a vast deal that should belong to others.

I have definitely come to the conclusion that these matters are becoming worse. It would seem that with the increase of officials all round the work of the Insurance Act is less efficiently performed than it was in its early days.—I am, etc.,

Felton, Northumberland, Feb. 7th.

ROBERT A. WELSH.

Evening Surgery.

SIR,—I was very glad to see Dr. Wightman's letter, in the SUPPLEMENT of February 5th, about evening surgeries in the country. As regards my own practice, which is a very scattered one, there has never been an evening surgery and no grounds of complaint have arisen on that account. Any urgent case is seen at the surgery at any time, and it is much more convenient for the great bulk of my patients, who reside several miles away, to be seen at their own homes. I think we should hold out strongly against compulsory evening surgeries. Surely we should be allowed a short space of leisure in the evenings after a strenuous day's work. We have precious little time as it is that we can call our own, our days and nights being often taken up with work.—I am, etc.,

Caxton, nr. Cambridge, Feb. 8th.

P. HUGHES DUDLEY.

LOCAL MEDICAL AND PANEL COMMITTEES.

BIRMINGHAM.

A MEETING of the Birmingham Panel Committee was held on February 1st, with Dr. DAIN in the chair. The Birmingham Insurance Committee intimated that the "datum line" in connexion with the scrutiny of prescriptions was, as suggested by the Panel Committee, fixed at 75 per cent. above the average cost of prescriptions issued during the previous quarter. In reply to a letter from the Dewshury Panel Committee suggesting the giving up of the use of the telephone by practitioners as a protest against the new rates, it was decided to take no steps.

The Secretary was instructed to write, protesting against the proposed Regulations under the Dangerous Drugs Act, to the Home Secretary, the Ministry of Health, the General Medical Council, the Royal Colleges of Surgeons and Physicians, to local Members of Parliament, University representatives in Parliament, and Sir Gilbert Barling.

It was decided to refrain from asking for a special conference of Panel and Local Medical Committees to consider the record cards, as had been requested by the Cheshire Panel Committee.

DEVON COUNTY.

The following resolution was passed at a meeting held on February 11th, 1921:

That the Devon County Panel Committee recognizes that the keeping of some form of continuous medical record is not only desirable in the interests of patients, but constitutes one of the duties of panel practitioners; and that such duty was definitely considered as part of the service to be paid for when the case for increased remuneration was put before the Arbitration Board in 1920; and that while it does not approve the present form as best suited for its purpose, the Committee advises Devonshire practitioners loyally to carry out the decision of the Conference of Representatives of Panel Committees in 1920, and to give the new record forms a trial before passing a formal opinion thereon.

Naval and Military Appointments.

ROYAL NAVAL MEDICAL SERVICE.

THE following appointments are announced by the Admiralty: Surgeon Commander R. Connell to the *Cleopatra*. Surgeon Lieut. Commanders H. E. R. Stephens, O.B.E., to the *Alacrity*, H. E. Scargill to the *Horvath*, W. J. Morris to the *Endeavour*. Surgeon Lieutenants J. H. B. Crosbie to the *Victory*, additional for Haslar Hospital, G. V. Hobbs to the *Iron Duke*, R. Biddle, O.B.E., to the *Hackbus*.

ARMY MEDICAL SERVICE.

Colonels T. V. Forrest, C.B., C.M.G., and S. L. Cummins, C.B., C.M.G., retire on retired pay.

ROYAL ARMY MEDICAL CORPS.

Lieut.-Colonel M. P. Corkery, O.B.E., is placed on the half-pay list on account of ill health.

Lieut.-Colonel J. Grech, D.S.O., retires on retired pay, November 23rd, 1920, and is granted the rank of Colonel (substituted for notification in the *London Gazette*, November 12th, 1920).

Major H. G. Pinches retires on retired pay, and is granted the rank of Lieutenant-Colonel.

Major J. A. Manifold, D.S.O., to be an assistant Professor, Royal Army Medical College.

The following relinquish the acting rank of Lieutenant-Colonel: Major H. T. Wilson, D.S.O., Captain and Brevet Major R. E. Barnsley, Major C. R. M. Morris, D.S.O.

The following Captains to be Majors: Brevet Major J. A. Manifold, D.S.O., S. S. Dykes, W. H. O'Riordan, M.C., C. T. V. Benson (acting Lieut.-Colonel) W. P. MacArthur, D.S.O., O.B.E., (acting Major) R. C. Priest, Brevet Major S. Tomlinson, D.S.O., (temporary Major) A. D. Stirling, D.S.O., G. P. Taylor, D.S.O., M.C., R. C. Paris, E. C. Lambkin, D.S.O., M.C., O. W. McSheehy, D.S.O., O.B.E., Brevet Major M. J. Williamson, M.C., C. L. Franklin, M.C., M. White, M.C., J. J. D. Roche, H. P. Joyn, A. S. M. Windsor, H. R. Edwards, J. R. Yonell, P. G. M. Elvery, D.S.O., M.C., J. J. H. Beekton, W. B. Rennie, M.C., W. Mathieson, O.B.E.

Captain L. F. K. Way, D.S.O., retires, receiving a gratuity, January 14th, 1921, and is granted the rank of Lieut.-Colonel. (Substituted for the notification in the *London Gazette*, January 13th, 1921.)

Temporary Captain W. L. Hay relinquishes the acting rank of Major.

The notification in the *London Gazette* of January 13th, 1921, regarding Major J. Startin, M.C., is cancelled.

The name of Captain Geoffrey Dowson Gripper is as now described, and not as in the *London Gazette* of May 9th, 1919.

To be Captains: Lieutenants (temporary Captains) P. A. Stewart, J. C. Collins, W. I. Fitzg., Powell, G. W. B. Shaw, W. C. Mackinnon. To be temporary Captains: F. W. Harlow, late temporary Captain, with seniority from December 19th, 1914; temporary Lieutenant O. T. J. C. de H. Clavre.

The following officers relinquish their commissions: Temporary Captains and retain the rank of Captain: R. Graut, J. Monroe, L. V. Gatt, C. F. Strange.

ROYAL AIR FORCE.

MEDICAL BRANCH.

The following are granted short service commissions as Flight Lieutenants, retaining their present seniority, with effect from February 4th: S. E. Duff, C. McC. Jones.

Flight Lieutenant R. Mugliston resigns his short service commission and is permitted to retain the rank of Captain.

F. R. Humphreys (Major R.A.M.C. T.F.) is granted a temporary commission as Flight Lieutenant and to be honorary Squadron Leader.

INDIAN MEDICAL SERVICE.

Major R. H. Bott, M.B., F.R.C.S., Professor of Operative Surgery, King Edward Medical College, Lahore, has been granted combined leave for eight months.

Lieut.-Colonel G. Tate, M.B., Officiating Professor of Midwifery, King Edward Medical College, Lahore, appointed to act as Professor of Operative Surgery in the College in addition to his own duties during the absence on leave of Major Bott.

Major W. S. Patton, M.B., has been placed on special duty under the Director-General, I.M.S.

Major J. McPherson appointed to hold charge of the current duties of the office of Political Agent, Eastern Rajputana States, in addition to his own duties (December 16th, 1920).

The following officers have been appointed to the service permanently, with effect from March 14th, 1920: B. Z. Shah, P. C. Banerjee, B. Sabai, D. B. Thapar.

The undermentioned officers have been permitted to retire from the service, with effect from the date specified:—Lieut.-Colonels: J. L. Macrae, October 21st, 1920; R. H. Castor, November 9th, 1920; J. Davidson, D.S.O., November 27th, 1920; C. A. Johnston, C.B., D.S.O., October 30th, 1920.

In the list of Majors promoted to be Lieutenant-Colonels, published in our issue of February 5th, p. 36, the name of G. Fowler was incorrectly printed.

TERRITORIAL FORCE.

ROYAL ARMY MEDICAL CORPS.

Major W. T. Rowe, M.C., to be Lieutenant-Colonel and command 3rd Northern Casualty Clearing Station.

Captains to be Majors: A. Robertson, O.B.E., R. G. Badenoch, G. T. Willan, D.S.O.

DIARY OF SOCIETIES AND LECTURES.

MEDICAL SOCIETY OF LONDON, 11, Chandos Street, W.1.—Mon., 9 p.m., Second Lettsoman Lecture by Mr. George E. Gask, C.M.G., D.S.O.: The Surgery of the Lung and Pleura.

MIDDLESEX HOSPITAL MEDICAL SCHOOL, W.—Emeritus Lectures, 3 p.m.—Tues., Sir A. Pearce Gould: Surgery. Fri., Sir R. Douglas Powell: Phthisis.

ROYAL COLLEGE OF PHYSICIANS, Pall Mall East, S.W.—Tues. and Thurs., 5 p.m., Dr. M. Ruth Flack: Miroly Lectures—Respiratory Efficiency in Relation to Health and Disease.

ROYAL COLLEGE OF SURGEONS, Lincoln's Inn Fields, W.C.—Mon., 5 p.m., Arris and Gale Lecture by Professor J. Howell Evans: The Azygos System of Veins in their Association with Surgical Affections.

ROYAL SOCIETY OF MEDICINE.—Section of Medicine: Guy's Hospital, Tues., 4-5.30 p.m., Tea, and Demonstrations by the Physicians and Assistant Physicians: 5.30 p.m., Dr. G. H. Hunt: Cardiac Efficiency; Mr. J. M. H. Campbell: Causation of Dyspnoea; Dr. J. A. Ryle: The Fractional Test Meal. Section of Tropical Medicine: Thurs., 5 p.m., Election of Officers and Council; Presidential Address by Sir Leonard Rogers; Paper by Dr. J. Gordon Thomson and Dr. A. Robertson: Laboratory Reports in the Diagnosis of Suspected Dysentery; Demonstrations by Professor Leiper and others. Section of Urology: Thurs., 8.30 p.m., Clinical and Pathological Evening; specimens will be shown. Section for the Study of Disease in Children: Fri., 4.30 p.m., Discussion on the Diagnosis and Treatment of Congenital Syphilis and its Effects, to be opened by Sir H. D. Rolleston and Mr. O. L. Addison. Section of Epidemiology and State Medicine: Fri., 8.30 p.m., Dr. R. M. F. Picken: Epidemiology of Measles in a Rural and Residential Area. Clinical, Medical, and Surgical Sections: Fri., 8.30 p.m., Adjourned Discussion on the Medical and Surgical Treatment of Graves's Disease; Mr. Donald Arnorn, Dr. J. M. H. Campbell, Mr. W. H. C. Romanis, Mr. A. J. Walton, Professor Earle, and others.

ST. JOHN'S HOSPITAL, 49, Leicester Square, W.C.2.—Thurs., 6 p.m., Dr. W. Griffith: Chesterfield Lecture—Diseases of the Skin Appendages.

POST-GRADUATE COURSES AND LECTURES.

GLASGOW POST-GRADUATE MEDICAL ASSOCIATION, Royal Maternity and Women's Hospital.—Wed., 4.15 p.m., Dr. S. J. Cameron: Obstetrical Cases.

HOSPITAL FOR SICK CHILDREN, Great Ormond Street, W.C.—Thurs., 4 p.m., Dr. T. Thompson: Neuritis.

MANCHESTER: ANCOATS HOSPITAL.—Thurs., 4.30 p.m., Dr. Stirling: Treatment of Common Eye Diseases.

MANCHESTER BABIES' HOSPITAL, Slade Lane.—Sat., 3.30 p.m., Dr. Chisholm: The Non-thriving Infant.

MANCHESTER ROYAL INFIRMARY.—Tues., 4.30 p.m., Mr. P. R. Wrigley: Choleraeitis.

MANCHESTER: ST. MARY'S HOSPITAL (Whitworth Street West Branch)—Fri., 4.30 p.m., Dr. Lacey: Toxaemias of Pregnancy.

NATIONAL HOSPITAL FOR DISEASES OF THE HEART, Westminster Street, W.1.—Mon., 5.30 p.m., Dr. Hamill: Myocardial Disease.

NATIONAL HOSPITAL FOR THE PARALYSED AND EPILEPTIC, Queen Square, W.C.1.—Daily (except Wed. and Sat.) 2 p.m., Out-patient Clinics. Lectures, 3.30 p.m.—Mon., Dr. K. Wilson: Hysteria; Tues., Dr. Collier: Diseases of the Cranial Nerves; Thurs., Mr. Scott: Disturbances of the Vestibular System; Fri., Dr. G. Stewart: Affections of the Pituitary Gland.

WEST LONDON POST-GRADUATE COLLEGE, Hammersmith, W.—Daily, 10 a.m., Ward Visits; 2 p.m., In- and Out-patient Clinics and Operations. Lectures, 5 p.m.—Mon., Dr. G. Stewart: Locomotor Ataxia; Tues., Dr. Burnford: Functions of the Digestive Tract; Wed., Mr. Armour: Abdominal Tumours; Thurs., Mr. S. Edwards: Rectal Surgery; Fri., Mr. Addison: Carcinoma of the Breast.

British Medical Association.

OFFICES AND LIBRARY, 49, STRAND, LONDON, W.C.2.

Reference and Lending Library.

THE READING ROOM, in which books of reference, periodicals, and standard works can be consulted, is open to members from 10 a.m. to 6.30 p.m., Saturdays 10 to 2.

LENDING LIBRARY: Members are entitled to borrow books, including current medical works; they will be forwarded, if desired, on application to the Librarian, accompanied by Is. for each volume for postage and packing.

Departments.

SUBSCRIPTIONS AND ADVERTISEMENTS (Financial Secretary and Business Manager, Telegrams: Articulate, Westrand, London). MEDICAL SECRETARY (Telegrams: Medisecra, Westrand, London). EDITOR, *British Medical Journal* (Telegrams: Aitiology, Westrand, London). Telephone number for all Departments: Gerrard 2630 (3 lines).

SCOTTISH MEDICAL SECRETARY: 6, Rutland Square, Edinburgh. (Telegrams: Associate, Edinburgh. Tel.: 4361 Central.)

IRISH MEDICAL SECRETARY: 16, South Frederick Street, Dublin. (Telegrams: Bacillus, Dublin. Tel.: 4737 Dublin.)

Diary of the Association.

FEBRUARY.

22 Tues. London: Whitley Council Subcommittee, 2.30 p.m.
24 Thurs. London: Dominions Committee, 3 p.m.

MARCH.

2 Wed. Camberwell Division.
3 Thurs. London: Executive Subcommittee of the Insurance Acts Committee.
4 Fri. Edinburgh Branch: Winter Clinical Meeting, Royal Infirmary, 3.15 p.m. Lecture by Dr. J. S. Haldane, 5 p.m.; Dinner, Caledonian Station Hotel, 6.30 p.m.

APRIL.

14 Thurs. Worcestershire and Herefordshire Branch: British Medical Association Lecture by Mr. P. L. Daniel, F.R.C.S., on the Differential Diagnosis of Acute Abdominal Conditions.

APPOINTMENTS.

BURGESS, Arthur H., F.R.C.S. Eng., M.B., M.Sc. Vict., Professor of Clinical Surgery in the University of Manchester.

MCDONALD, Niel, O.B.E., M.B., Ch.B. Vict., M.R.C.S., L.R.C.P. Lond., Anaesthetist to the Great Northern Central Hospital, London, N.

MACEWEN, William, O.B.E. (Military), M.B., Ch.B., D.P.H., Assistant Medical Officer of Health and Assistant School Medical Officer for Birkenhead.

MACGARROL, R., M.B., Ch.B., Assistant Medical Officer to the Stobhill Hospital, Springburn, Glasgow.

SCHARFF, J. W., M.B., D.P.H. Dub., Assistant Health Officer (Rural), Singapore.

STANNUS, H. S., M.D., M.R.C.P. Lond., Medical Adviser to the Board of Inland Revenue.

ST. THOMAS'S HOSPITAL.—The following appointments have been made:—Casualty Officers and Resident Anaesthetists: G. A. Back, M.R.C.S., L.R.C.P., E. D. Granger, M.B., B.S. Lond., C. K. J. Hamilton, M.C., B.A., M.B., B.Ch. Oxon., J. T. S. Hoay, M.A., M.B., B.Ch. Oxon., P. T. Liang, M.A., B.Ch. Cantab., D.T.M., A. D. Whitelaw, B.A. Cantab., M.R.C.S., L.R.C.P., Resident House-Physicians: L. B. Maxwell, O.B.E., B.A. Cantab., M.R.C.S., L.R.C.P., A. T. Hawley, B.A. Cantab., M.R.C.S., L.R.C.P., G. M. Kendall, M.B. Cantab., Resident House-Physician (for Children): F. B. Hobbs, B.A., M.B., B.Ch. Cantab., Resident House-Surgeons: D. G. Garnett, B.A. Cantab., M.R.C.S., L.R.C.P., W. A. Low, M.C., M.R.C.S., L.R.C.P., Obstetric House-Physicians: (Senior) C. D. Maitland, M.B., B.S. Lond., F.R.C.S.; (Junior) E. S. Orme, B.A. Cantab., M.R.C.S., L.R.C.P., Clinical Assistants: (Throat) F. G. Wood, M.A., B.Ch. Cantab.; (Skin) S. H. G. Humfrey, B.A. Cantab., M.R.C.S., L.R.C.P.; (Ear) R. H. O. B. Robinson, B.A., M.B., B.Ch. Cantab.; (Children's Medical) J. A. P. Shaw, B.A. Cantab., M.R.C.S., L.R.C.P., R. N. L. Symes, M.R.C.S., L.R.C.P.; (Tuberculosis Department) G. D. C. Tracey, B.A. Cantab., M.R.C.S., L.R.C.P., K. H. Tallerman, M.C., B.A. Cantab., M.R.C.S., L.R.C.P.; (Electrical and X-Ray Department) B. Shires, M.B., Ch.B. Edin.; (Orthopaedic) C. L. C. Burns, M.R.C.S., L.R.C.P.; (Mental) C. J. Thomas, M.R.C.S., L.R.C.P.; (Electro-cardiograph) B. T. Parsons Smith, M.D. Lond. Several other gentlemen have received extensions of their appointments.

BIRTHS, MARRIAGES, AND DEATHS.

The charge for inserting announcements of Births, Marriages, and Deaths is 9s., which sum should be forwarded with the notice not later than the first post on Tuesday morning, in order to ensure insertion in the current issue.

BIRTH.

CRAWFORD.—February 10th 1921, at 245, Lower Circular Road, Calcutta, the wife of Lieut.-Colonel V. J. Crawford, D.S.O., R.A.M.C., of a daughter.

DEATH.

GARD.—On February 13th, at a nursing home, William John Gard, M.R.C.S. Eng., L.R.C.P. Lond., beloved husband of Julia Mary Gard, of 2, Clarendon Terrace, Stoke, Devonport, aged 68 years. Friends please accept this the only intimation.

SUPPLEMENT

TO THE

BRITISH MEDICAL JOURNAL.

LONDON: SATURDAY, FEBRUARY 26TH, 1921.

CONTENTS.

	PAGE		PAGE
BRITISH MEDICAL ASSOCIATION.		CONFERENCE OF STAFFS OF VOLUNTARY HOSPITALS IN SCOTLAND 50	
CURRENT NOTES:		INSURANCE:	
MEETING OF COUNCIL	49	CONFERENCE OF REPRESENTATIVES OF PARLIAM. COMMITTEES (GROUP F) AT BIRMINGHAM	51
DANGEROUS DRUGS REGULATIONS	49	DIARY OF SOCIETIES AND LECTURES	52
THE ARMY MEDICAL SERVICE	49	ASSOCIATION INTELLIGENCE	52
I.M.S. PAY—CIVIL BRANCH	50	POST-GRADUATE COURSES AND LECTURES	52
ASSOCIATION NOTICES:		BIRTHS, MARRIAGES, AND DEATHS	52
SUGGESTED CHANGES OF AREAS	50		
BRANCH AND DIVISION MEETINGS TO BE HELD	50		
MEETINGS OF BRANCHES AND DIVISIONS	50		

British Medical Association.

CURRENT NOTES.

Meeting of Council.

At the meeting of the Central Council held on February 16th congratulations were accorded to Sir Dawson Williams, Sir Squire Sprigge, Sir Charles Ryall, Sir William Hodgson, and Sir Alexander J. Hood of Sydney, on the knighthoods conferred on them at the New Year. Dr. J. A. Macdonald gave an extremely interesting account of his recent visit to the South African Branches, and the welcome he received everywhere throughout his tour. The Council expressed its pleasure at the conspicuous success with which Dr. Macdonald had acted as its representative in South Africa. Among the many important matters discussed was that of the steps to be taken whereby the Association may become in part a federation. The Council approved for publication in an early issue of the SUPPLEMENT an exhaustive report on this subject submitted in draft by the Organization Committee, and resolved to convene an extraordinary general meeting of the Association, to be held at Newcastle on July 19th, 1921, immediately after the statutory Annual General Meeting, for the purpose of adopting the amended articles and by-laws. An account of the complimentary luncheon given to Sir Dawson Williams, Editor of the BRITISH MEDICAL JOURNAL, by the Council, appears in the JOURNAL at p. 309. The usual report of the proceedings of Council will shortly be published in the SUPPLEMENT; but the position in regard to the draft Dangerous Drugs Regulations, as reported to the Council on February 16th, is described in a Current Note below.

Dangerous Drugs Regulations.

The Divisions of the Association and the Local Medical and Panel Committees are to be congratulated on the prompt way in which most of them have taken action in regard to the Regulations of the Home Office under the Dangerous Drugs Act. The Home Office has received many communications from individual doctors as well as from Divisions and Local Medical and Panel Committees, and many members of Parliament have been stimulated to action in regard to these unfortunate Regulations.

As reported in Current Notes last week, the Home Office has sent a statement of the modifications it is prepared to make in the Regulations; and this was considered by the Council on February 16th. The letter, summarized, states:

1. That there is no reason why prescriptions should not be either typewritten or printed.

2. That it is recognized that it will not be necessary to write the words "not to be repeated" on a prescription containing one of the drugs.

3. That the Regulations were not intended to try to get a record of drugs administered personally or under the direct supervision of a practitioner—that direct administration would not be held to be "supply" under the Regulations.

4. Suggestions are made for the simplification of the record demanded, and it is proposed now that one book instead of four shall be kept for the record so long as each of the four drugs is dealt with on separate pages, and that in the record, in addition to the date, name and address of the patient, it should only be necessary to make a cross reference to the prescription containing the drugs in the doctor's day book.

5. That Regulation 8 does not apply to preparations of the drugs which contain less than the percentages mentioned in Regulation 1, and that therefore the Association is in error in supposing that any package or bottle containing any preparation which contains one of the drugs, in whatever proportion, was intended to be marked with the name of the drug and the percentage thereof on the label. The Secretary of State is, moreover, prepared to drop the suggestion that the name and quantity of the drug shall be stated on the label of any medicine dispensed by a doctor or by a chemist on a doctor's prescription.

6. It will not be necessary to keep records at each separate branch surgery or house of call. All that will be required will be a record wherever the doctor keeps a separate day book.

7. There will be no difficulty about a doctor getting a supply of drugs by a telephone message, and alterations will be made in the Regulations to make it quite clear that the delivery by a chemist to his own messenger or to any common carrier for the purpose of delivery at a doctor's house is not intended to be covered by the Regulation.

The Council decided to express no opinion on the new proposals of the Home Office until the Regulations have been seen in their new form, and the Home Office has been so informed. In the meantime the Association, in conjunction with the British Dental Association, the Pharmaceutical Society of Great Britain, and other bodies concerned, is pressing the Home Secretary to receive a deputation, to urge on him (1) that Regulations of this kind should not have been issued, and shall not in future be issued, until the organizations concerned have been effectively consulted; (2) that the draft Regulations should be withdrawn pending the discussion of the subject by a small expert committee.

The attitude of the profession should continue to be one of great vigilance, as it may be necessary to call upon Parliament to object to the draft Regulations if the Home Office insists on placing them before the House without reference to an expert committee.

The Army Medical Service.

The attention of the Association has been called to an Army Order altering the dress distinctions on the cap and tunic of general officers and officers of the administrative staff, and it is understood that this is causing a considerable amount of irritation in the R.A.M.C. and amongst the officers concerned. It is unfortunate, from the point of

view of the medical profession, that such action should have been taken, as it appears to mean the restoration of class distinctions between medical and combatant officers. This element of class distinction created much discontent in the Medical Service of the Army in the years before it was constituted a Royal Corps, and it is a well-known fact that the professional efficiency of the R.A.M.C. made great advances as a result of its abolition, with corresponding advantage to the Army as a whole. The most bitter opponents of the changes which were then made in ranks and titles of medical officers now recognize their value. When the war broke out, the only rank which might be called a class distinction rank was that of surgeon-general, and this was altered to major-general early in 1918. Major-Generals, A.M.S., then wore the scarlet cap and gorget patches of the rank, while officers of the administrative medical staff of junior rank wore the blue cap band and gorget patches of other administrative staff officers. The new Army Order changes all this. Major-Generals, A.M.S., must now revert to the black velvet band and patches of surgeon-general, while administrative medical officers revert to bands and patches of dull cherry, the colour of the R.A.M.C. facings. The class distinction introduced by the new Order is made more significant by the fact that, although it affects the small number of senior officers of the Royal Army Ordnance, Veterinary, and Pay Corps, it does not affect those in the Royal Army Service Corps or the many officers of general rank who are, or were, employed on duties which were quite as far removed from combatant work as that of the A.M.S. It will be the duty of the Association to watch the effect of this Order, and to take any steps that may appear necessary to safeguard the interests of R.A.M.C. officers.

I.M.S. Pay—Civil Branch.

The Association has received a number of complaints from I.M.S. officers in civil employ owing to the fact that they have not yet received the increase of pay as promised last July. Very strong representations have been made to the India Office, and a letter has been received stating that a telegram has been sent to the Government of India asking that adjustment of arrears and pay due under the new scale shall be specially expedited. Representations have also been made privately, and the Chairman of the Committee has been given an unequivocal promise from a high quarter that the undertaking of the Secretary of State will be kept in full and that all back pay which is due will be given. The Naval and Military Committee is watching this matter very closely, and officers of the I.M.S. may confidently leave their interests in its hands.

Association Notices.

SUGGESTED CHANGES OF AREAS.

Proposed Ealing Division.

NOTICE is hereby given to all concerned of a proposal, made at a meeting of the members of the Association resident in the Ealing district, held on February 17th, 1921, that so much of the present South Middlesex Division as is contained within the Municipal Borough of Ealing, the Urban Districts of Hayes, Greenford, Southall-Norwood, Hanwell, Acton, Chiswick, and Brentford, be detached from that Division to form a separate Division, to be called the Ealing Division. Written notice of the proposal has been given to the Metropolitan Counties Branch and the South Middlesex Division, and the matter will be determined in due course by the Council. Any member affected by the proposed change, and objecting thereto, is requested to write, giving the reason therefor, to the Medical Secretary, 429, Strand, W.C., not later than March 26th, 1921.

BRANCH AND DIVISION MEETINGS TO BE HELD.

EDINBURGH BRANCH.—The winter clinical meeting of the Edinburgh Branch will be held in the Royal Infirmary on Friday, March 4th. All members of the profession are cordially invited. The museum will be open from 11 a.m. Arrangements will be made for holding special clinics during the forenoon. The clinical meeting will be held at 3.15 p.m. At 5 p.m. Dr. J. S. Haldane, LL.D., F.R.S., Oxford, will deliver a lecture on "Some recent advances in the physiology of respiration, circulation, and renal excretion." There will be dinner at 6.30 p.m. in the Caledonian Station Hotel; morning dress; dinner ticket, price 10s. 6d. Members of the Branch are requested to notify the Honorary Secretaries not later than February 28th whether or not they intend to be present.

METROPOLITAN COUNTIES BRANCH: CAMBERWELL DIVISION.—A meeting of the Camberwell Division will be held on Wednesday, March 2nd, when Dr. H. C. Cameron, of Guy's Hospital, will give an address on Children.

METROPOLITAN COUNTIES BRANCH: CITY DIVISION.—A meeting of the City Division will be held at the Metropolitan Hospital on Wednesday, March 2nd, at 9.15 p.m., when Mr. McAdam Eccles will give a British Medical Association lecture on the Early Diagnosis of Acute Abdomens. A general meeting of the Division will be held on March 9th, and a dinner-dance will take place at the Abercorn Rooms, Great Eastern Hotel, on March 31st.

Meetings of Branches and Divisions.

METROPOLITAN COUNTIES BRANCH: EALING DIVISION.

A MEETING of the members of the Association in Ealing and the neighbourhood, held at Ealing Broadway on February 17th, was well attended by practitioners from all parts of this area.

After some introductory remarks by Dr. GOODALL, President of the Metropolitan Counties Branch, Dr. J. W. BELL (North Ealing) was unanimously elected to the chair.

The following resolution was unanimously passed:

That the Council of the British Medical Association be requested to constitute a new Division of the Association, to be called the Ealing Division, which shall include all members resident in the borough of Ealing, the urban districts of Hayes, Greenford, Southall-Norwood, Hanwell, Acton, Chiswick, and Brentford.

The following officers were elected:

Chairman: Dr. J. W. Bell (Ealing). *Honorary Secretary:* Dr. J. A. Davidson (Golden Manor House, Hanwell). *Executive Committee:* Dr. Thomas Orr (Ealing), Dr. S. M. Banham (Ealing), Dr. Agnes Dunnell (Ealing), Dr. J. L. Timmins (Acton), Dr. G. Thomson (West Ealing), Dr. H. H. Tomkins (South Ealing), and Dr. A. H. Hart (Southall). *Representatives on Branch Council:* Dr. J. A. Davidson, and Dr. Agnes Dunnell.

Dr. ANDERSON, Deputy Medical Secretary of the Association, having spoken on the services rendered by the Association in the interests of its members, an animated debate followed. Questions were asked, and answered by Dr. ANDERSON and Mr. BISHOP HARMAN. Confidence in the power of the Association to help its members was freely expressed, and the proceedings terminated with a cordial vote of thanks to the Deputy Medical Secretary and members and officials of the Branch who visited Ealing for the occasion.

MALAYA BRANCH.

A Correction.

In the report of the proceedings of the Malaya Branch, published on December 18th, 1920, p. 166, it was incorrectly stated that the salaries paid to medical practitioners in the Government service were *inadequate*; it should have been stated that the meeting considered that the salaries were *adequate*.

CONFERENCE OF STAFFS OF VOLUNTARY HOSPITALS IN SCOTLAND.

A CONFERENCE of representatives of the honorary medical staffs of voluntary hospitals in Scotland, convened by the Hospitals Subcommittee of the Scottish Committee, was held in the offices of the Association, 6, Rutland Square, Edinburgh, on February 5th, to consider what is the general opinion of hospital staffs as to how the present financial difficulties of voluntary hospitals should be met. All the teaching hospitals were represented, as well as a large number of the smaller general and special hospitals throughout the country. Dr. R. C. BURST, Chairman of the Hospitals Subcommittee, presided.

It was moved on behalf of the Hospitals Subcommittee:

That the voluntary method of administration of the voluntary hospitals of the country should be maintained.

Dr. NORMAN WALKER moved an amendment:

That the present methods of administration of the voluntary hospitals should be continued.

He instanced the difficulty of defining "voluntary," and argued that where so many differences of opinion existed and when so many proposals were being considered, some of which might be thought to conflict with the voluntary principle, it was better to adopt a resolution in general terms which would cover everything that was at the present time regarded as voluntary.

The CHAIRMAN, on behalf of the Subcommittee, accepted the proposal, and called for a discussion on the general question.

Dr. STEPHEN (Banff) said he had been instructed to oppose the motion. He and his colleagues felt that it was no longer possible to carry on the smaller hospitals and to provide the necessary up-to-date equipment from voluntary sources alone, and that they must look for help from the State or elsewhere. Dr. McFARLAN (Stirling) said that the staff of his infirmary took the same attitude.

Dr. WALKER, in reply, pointed out that while changes might be required in connexion with some hospitals, they

would not be wanted everywhere. He, in common with the majority of people who considered this question, wished the voluntary principle to be maintained as far as possible.

The motion was agreed to.

The second motion standing in the name of the Subcommittee—

That necessitous persons shall continue to be treated free.— was withdrawn, the meeting being of opinion that the principle was sufficiently expressed in the previous motion.

Considerable discussion took place on the next motion, proposed by the Hospitals Subcommittee:

That it is undesirable that the voluntary hospitals should be subsidized by the local rating authorities, except in so far as payment is made for the examination and the care of patients for whom these authorities are responsible.

Dr. WALKER moved as an amendment:

That except under special circumstances it is not desirable that voluntary hospitals should be subsidized by the local rating authorities.

He preferred "not desirable" to "undesirable" as being less committal. The whole motion was too specific, and they would require a definition of the word "subsidized."

Dr. TROTTER (Perth), who seconded the amendment, said that Perth Royal Infirmary had approached the local authorities for relief of rates on the ground that they were a voluntary hospital.

Dr. BALLANTYNE (Glasgow) asked if the motion would preclude the acceptance of subscriptions from the local authority out of the "Common Good." He suggested that an addition should be made to show that it was taking money out of the rates that was objected to.

The CHAIRMAN pointed out that a corporation might make a contribution in its capacity as an employer or in return for beds being retained for a special purpose. Such a contribution would be in keeping with the voluntary principle, but a contribution given as a rating authority on behalf of the citizens raised a very different issue.

Dr. STEVENS (Edinburgh) supported the motion in that it supported the principle of payment for work done, and would not in any way compromise the hospital accepting payment. Professor MONRO (Glasgow) also supported the motion, objecting to the amendment as lacking in definiteness.

Dr. SNODGRASS (Chairman of the Scottish Committee), said that if they had a regular subsidy from the corporation they would have regularized control. "We want" (he said) "to avoid the hospitals being controlled by the State or municipality. We do not object to voluntary subscriptions from a corporation, but we object to a regularized system which would involve control."

The amendment was rejected, and the motion was carried with the substitution of "not desirable" for "undesirable."

The next motion was by the Hospitals Subcommittee:

That greatly extended support for voluntary hospitals should be sought from employers, employees, and insurance companies.

An amendment by Dundee Royal Infirmary to insert "and organized" between the words "extended" and "support" was accepted.

An amendment was proposed by Dr. NORMAN WALKER:

That the ever-increasing demand for the upkeep and extension of the existing and the provision of new hospitals necessitates an appeal to all sections of the community for increased support.

He wanted to broaden this motion for many reasons. Most hospitals had managed to carry on last year only by making a very special effort, and it was doubtful if this special effort could be made again. More hospital beds were required, and he could not see where the money was to come from to provide them. All classes of the community benefited, directly or indirectly, from the existence of the voluntary hospitals, and it ought to be brought home to the public how much they had benefited.

Professor MACKINTOSH supported the amendment, and felt that it would be a mistake to seem to pillory employers in this way. Mr. WADE thought it most desirable that the motion should not be altered since all present were prepared to defend the voluntary principle. If the voluntary principle did best for the country, then it must be maintained. Employers were beginning to realize more and more how much they benefited financially from the work done in hospitals.

After further discussion the motion was carried by a small majority, and the following rider was agreed to:

That the ever-increasing demand for the upkeep and extension of existing hospitals and for the provision of new hospitals necessitates greatly extended and adequately organized support by all sections of the community.

The Hospitals Subcommittee proposed:

That every patient of a voluntary hospital who is not a necessitous person should make a contribution, during treatment, towards the cost of maintenance, except where the contributory method of subscription is adopted as essential in industrial areas.

Professor MONRO (Glasgow Western Infirmary) opposed the motion. He objected to the principle, and believed it would be difficult to carry out in practice, with any degree of justice. Professor BOYD (Edinburgh Royal Infirmary) also opposed it, and said that the Royal Infirmary staff could not accept the motion.

Mr. PRINGLE (Glasgow Royal Infirmary) said the position in Glasgow was different from that in Edinburgh, because patients were not admitted to the Glasgow Royal Infirmary without a subscriber's line. The staff were unanimously of opinion that some steps should be taken to obtain contributions from patients who were able to pay. Dr. DIXON (Hawick) said that the principle had always obtained in their hospital and there had never been any difficulty. Dr. WALKER believed the contributory method promised the best results; the exacting of payment from patients would conflict with it, and would meet with opposition from the managerial side.

Professor MACKINTOSH (Aberdeen), though he agreed that patients did not give nearly as much as they ought to, could not agree to the proposal to make it a rule that persons under treatment should make a contribution.

The motion was rejected.

A motion that hospital almoners should be appointed was also lost.

The following was agreed to unanimously:

That where voluntary hospitals provide accommodation for patients who are able to pay for maintenance and treatment no fixed rate of payment for professional services rendered to such patients should be established, the fees so payable to remain as at present a matter of arrangement between patient, family physician, and consultant.

The motion by the Hospitals Subcommittee—

That in the event of decisions being taken which would lead to patients paying, in part or in whole, the hospital maintenance fees, either individually or by some contributory method, or with the addition of rate aid or State aid, or by a combination of two or more of these methods, a percentage of all such payments shall be passed into a fund which can be allocated in any manner which such honorary medical staff may determine.—

was rejected in favour of the resolution of the former Conference—namely:

That when a hospital receives payment from any public body for the treatment of individual cases a reasonable proportion of the amount received be put at the disposal of the medical staff.

The following motion by Glasgow Royal Infirmary was referred to the Hospitals Subcommittee for inquiry and action:

That in respect that the training and education of nurses is a branch of secondary education, voluntary hospitals, which are recognized training schools for nurses, should receive Government grants-in-aid as are given to schools for ordinary secondary education.

It was unanimously resolved:

That this Conference of Representatives of Medical Staffs of Voluntary Hospitals of Scotland, convened by the British Medical Association, considers that the questions discussed by the Conference are of great importance and by no means solved as yet. The Conference therefore believes it would be well to have the mechanism whereby a similar conference could be called as and when necessary. To this end the Conference desires to ask the Scottish Committee to authorize its Hospitals Subcommittee to call a Conference when deemed desirable.

The meeting concluded with a vote of thanks to the Chairman for his conduct of the business.

INSURANCE.

CONFERENCE OF REPRESENTATIVES OF PANEL COMMITTEES (GROUP F) AT BIRMINGHAM.

A MEETING of Representatives of Panel Committees comprising Group "F" was held at Birmingham on February 8th.

The SECRETARY (Birmingham Panel Committee) stated that no replies had been received to the invitations sent for the meeting from Burton on Trent, Worcester, Derbyshire, Derby and Leicestershire.

Dr. DAM (Chairman of the Birmingham Panel Committee) explained the objects of the conference, and said that he had been asked by his committee to arrange for a meeting of representatives of Panel Committees forming Group "F," to consider the formation of a Standing Joint Committee for that group, that in several groups such a committee had already been formed and found to be very useful. He stated that if it was decided to form one for Group "F," he thought the

Birmingham Panel Committee would be pleased to offer their room for the purpose of holding the meetings, and this offer was accepted.

Dr. Dain was then elected chairman for the meeting, and on a motion by him, it was decided to form a Standing Joint Committee. Several members considered that such a committee would be very useful and would strengthen the hands of their representatives on the Insurance Acts Committee.

The model scheme for the constitution of a Standing Joint Committee contained in M. 28 British Medical Association, was then considered, and the following scheme adopted:

1. There shall be a Standing Joint Committee for those Local Medical and Panel Committees comprised in Group "F," which jointly nominate two members for election on the Insurance Acts Committee.

2. The objects of the Standing Joint Committee shall be:

(i) To consider any matter affecting the welfare of insurance practitioners, and to take such action as may be deemed to be necessary in the interests of the insurance practitioners in the group.

(ii) To enter into any arrangements with neighbouring Local Medical and Panel Committees or group committees thereof, for similar purposes to those stated in Clause (i).

3. The Committee shall be called the "Group 'F' Standing Joint Committee of Local Medical and Panel Committees."

4. The following Local Medical and Panel Committees shall be deemed to be members of the group, but the list shall be corrected in accordance with any fresh grouping which may in future be adopted for the constitution of the Insurance Acts Committee:

Staffordshire	Burton-on-Trent	Stoke-on-Trent
Smethwick	Walsall	West Bromwich
Wolverhampton	Warwickshire	Birmingham
Coventry	Worcestershire	Dudley
Worcester	Herefordshire	Shropshire
Derbyshire	Derby	Leicestershire
Leicester		

5. Each of the Panel Committees comprised in the group under Article (4) hereof shall appoint one representative and a deputy to this Standing Joint Committee, and these shall be elected annually at the annual meetings of the respective committees comprised in the group, and shall be eligible for re-election. The representatives with any members of the Insurance Acts Committee who reside in the area of the group (who shall be *ex officio* members) shall constitute the Standing Joint Committee of the group.

6. The officers of the Standing Joint Committee shall be chairman, vice-chairman, secretary, and treasurer.

7. The Standing Joint Committee shall meet half-yearly in the months of April and September, also before any special conference of Local Medical and Panel Committees.

8. Special meetings shall be held at the discretion of the chairman (or, in his absence, the vice-chairman), or at the request of not less than six members of the Standing Joint Committee.

9. Two weeks' notice shall be given of the holding of all regular meetings; and for special meetings not less than three days' notice, and not more than seven days' notice, when called on demand.

10. An annual capitation, the amount of which shall be fixed annually in accordance with the requirements of the Joint Committee, but shall not exceed . . . per practitioner on the respective panel lists, shall be paid by each Panel Committee to the treasurer to meet the expenses of the Standing Joint Committee.

(A discussion here took place as to the amount to be fixed, and it was decided that this should be brought up again at the next meeting, after the representatives had reported to their committees.)

11. An annual financial statement shall be prepared by the treasurer and presented to the meeting held in the month of April in each year.

Dr. CROFTS (Leicester) suggested on behalf of his committee that Group "F" be divided into two single-member constituencies for the purpose of electing representatives on the Insurance Acts Committee. After some discussion, it was decided that the various Panel Committees should consider the proposal and their views be brought forward at the first meeting of the Standing Joint Committee.

On the motion of Dr. RIDLEY BAILEY (Insurance Acts Committee), the following resolution regarding the proposed Regulations in connexion with the Dangerous Drugs Act was carried unanimously:

That the representatives of the Panel Committees comprising Group "F" assembled in conference in Birmingham, strongly protest against the proposed Regulations of the Dangerous Drugs Act, and call upon the Government to withdraw the Regulations affecting the medical profession, as they are impracticable to carry out and likely to militate against the proper use of the drugs scheduled.

The Secretary was asked to forward a copy of the resolution, together with a list of the Panel Committees referred to, to the Prime Minister, the Chancellor of the Exchequer, the Chancellor of the University of Birmingham (Right Hon. Lord Robert Cecil, M.P.).

Drs. DAIN and RIDLEY BAILEY referred to several matters at present being discussed by the Insurance Acts Committee with the Government.

It was decided to hold the first meeting of the Standing Joint Committee on Thursday, April 14th, at 3.15 p.m., the business to be to elect officers; and the Secretary of the Birmingham Panel Committee was asked to send out the notices.

DIARY OF SOCIETIES AND LECTURES.

MEDICAL SOCIETY OF LONDON, 11, Chandos Street, W.1.—Mon., 8.30 p.m., Discussion on the Chemical Estimation of Gastric Function, to be introduced by Dr. J. H. Ryffel, M.A., Dr. J. A. Kyle, Dr. T. I. Bennett, Dr. R. L. M. Wallis, Mr. E. C. Dodds, Dr. G. Graham, Dr. C. Bolton, Dr. R. Hutchison, Dr. W. H. Wilcox.

MIDDLESEX HOSPITAL MEDICAL SCHOOL, W.—Emeritus Lectures, 3 p.m.—Tues. and Thurs., Dr. W. McC. Wanklyn: Future of the Medical Profession.

ROYAL COLLEGE OF PHYSICIANS, Pall Mall East, S.W.—Tues. and Thurs., 5 p.m., Dr. George Graham: Goulstonian Lectures—Glycaemia and Glycosuria.

ROYAL SOCIETY OF MEDICINE.—Section of *Otolaryngology*: Mon., 8 p.m., Mr. W. W. James: Dental Infection; Mr. P. Cole: Pedicle Bone Grafts Two Years after Operation. Section of *Surgery, Subsection of Orthopaedics*: Tues., 5 p.m., Cases; 5.30 p.m., Discussion on Recurrent Dislocations (Shoulder, Patella, etc.) and their Treatment, opened by the President, Mr. Laming Evans (Shoulder); Mr. W. Rowley Bristow (Patella). Examples of the condition will be shown. Section of *Pathology*: Bacteriological Department, Guy's Hospital, S.E.1, Tues., 8.30 p.m., Demonstrations, Dr. E. P. Poulton: (1) Modification of Van Slyke's Method of Measuring Oxygen in Blood; (2) Method of Obtaining Alveolar Air Samples in Untrained Persons. Section of *Surgery*: Wed., 5.30 p.m., Demonstration, Mr. Edred M. Corner: The Fate of Silk Nerve Regeneration, and Internal Scars (Amputations); Pathological Specimens, Skiagraphic Plates, Prints, and Illustrations will be on view at 4.30 p.m. Section of *Obstetrics and Gynaecology*: Thurs., 8 p.m., Specimens, Dr. Russell Andrews: (1) Two Cases of Sarcoma of the Uterus; (2) Lipomatosis of Stroma of a Uterine Fibromyoma; Papers, Dr. Geoffrey Evans: The Arteries in a Uterus twenty-four days after Delivery; Dr. Alec Bourne: Puerperal Salpingo-peritonitis. Section of *Laryngology*: Fri., 4 p.m., Cases, Section of *Anaesthetics*: Fri., 8.30 p.m., Mr. R. Apperly: Importance of Examination by Anaesthetist of Patient.

ST. JOHN'S HOSPITAL, 49, Leicester Square, W.C.2.—Thurs., 6 p.m., Dr. W. Griffith: Chesterfield Lecture—Skin Eruptions of Syphilis.

TUBERCULOSIS SOCIETY OF GREAT BRITAIN AND IRELAND, Margaret Street Hospital, W.1.—Mon., 7.30 p.m., Dr. W. Gordon: Rain-bearing Winds and Tuberculosis.

British Medical Association.

OFFICES AND LIBRARY, 429, STRAND, LONDON, W.C.2.

Departments.

SUBSCRIPTIONS AND ADVERTISEMENTS (Financial Secretary and Business Manager, Telegrams: Articulate, Westrand, London), MEDICAL SECRETARY (Telegrams: Medisera, Westrand, London), EDITOR, *British Medical Journal* (Telegrams: Aitology, Westrand, London).

Telephone number for all Departments: Gerrard 2630 (3 lines).

SCOTTISH MEDICAL SECRETARY—6, Rutland Square, Edinburgh. (Telegrams: Associate, Edinburgh. Tel.: 4361 Central.)

IRISH MEDICAL SECRETARY: 16, South Frederick Street, Dublin. (Telegrams: Bacillus, Dublin. Tel.: 4737 Dublin.)

Diary of the Association.

- FEBRUARY.
- 25 Fri., London: Medico-Sociological Committee, 2.30 p.m.
- MARCH.
- 2 Wed., Camberwell Division.
City Division: British Medical Association Lecture by Mr. MeAdam Eccles on Early Diagnosis of Acute Abdomens, Metropolitan Hospital, 9.15 p.m.
- 3 Thurs., London: Executive Subcommittee of the Insurance Acts Committee.
- 4 Fri., Edinburgh Branch: Winter Clinical Meeting, Royal Infirmary, 3.15 p.m., Lecture by Dr. J. S. Haldane, 5 p.m.; Dinner, Caledonian Station Hotel, 6.30 p.m.
- 8 Tues., London: Scrutiny Subcommittee, 2 p.m.
- 9 Wed., City Division: General Meeting.
- 16 Wed., London: Joint Conference of Ministry of Health, Medico-Political, Hospitals, and Public Health Committees, 2 p.m.
- 18 Fri., North of England Branch, Mental Hospital, Ryhope, 3 p.m., Professor J. Middlemiss: Incipient Insanity.

POST-GRADUATE COURSES AND LECTURES.

- GLASGOW POST-GRADUATE MEDICAL ASSOCIATION, Ear, Nose, and Throat Hospital.—Wed., 4.15 p.m., Members of the Staff: Cases.
- HOSPITAL FOR SICK CHILDREN, Great Ormond Street, W.C.—Thurs., 4 p.m., Dr. A. M. H. Gray: Itching in Children.
- MANCHESTER BABIES' HOSPITAL, Slade Lane.—Sat., 3.30 p.m., Dr. Hickling: Tickets.
- MANCHESTER ROYAL INFIRMARY.—Tues., 4.30 p.m., Dr. C. H. Melland: Heart Disease.
- MANCHESTER: ST. MARY'S HOSPITALS (Whitworth Street West Branch).—Fri., 4.30 p.m., Dr. Douglas: Tumours Complicating Labour, Pregnancy, and the Puerperium.
- NATIONAL HOSPITAL FOR DISEASES OF THE HEART, Westminster, W.1.—Mon., 5.30 p.m., Dr. Moon: Arterio-sclerosis.
- NATIONAL HOSPITAL FOR THE PARALYSED AND EPILEPTIC, Queen Square, W.C.1.—Daily (except Wed. and Sat.) 2 p.m., Out-patient Clinics, Lectures, 3.30 p.m.—Mon., Dr. K. Wilson: Functional Nervous Disease; Tues., Mr. Armour: Cervical Ribs; Thurs., Dr. G. Holmes: Muscular Atrophies, Fri., 3.30 p.m., Dr. Tooth: Demonstration of Cases.
- NORTH-EAST LONDON POST-GRADUATE COLLEGE, Prince of Wales's General Hospital, Tottenham, N.15.—Daily, 2 p.m., In-patient and Out-patient Clinics, Operations, etc. Lecture-Demonstrations.—Mon., 4.30 p.m., Mr. Banister: Pyelitis in Pregnancy; Tues., 3 p.m., Mr. Howell Evans: Surgical Cases; Wed., 3 p.m., Dr. Oliver: Skin Cases; Thurs., 3 p.m., Dr. Provis: Modern Treatment of Syphilis; Fri., 3 p.m., Mr. Gillespie: Surgical Cases.
- SALFORD ROYAL HOSPITAL.—Thurs., 4.30 p.m., Dr. Gibson: Scorbolic Dermatitis.
- WEST LONDON POST-GRADUATE COLLEGE, Hammersmith, W.—Daily, 10 a.m., Ward Visits; 2 p.m., In- and Out-patient Clinics and Operations; Lectures, 5 p.m.—Mon., Dr. G. Stewart: General Paralysis of the Insane; Tues., Mr. Grey: Surgical Disorders of Stomach and Duodenum; Wed., Mr. Armour: Abdominal Tumours; Thurs., Sir A. Garrod: Interaction of the Glands of Internal Secretion; Fri., Mr. Addison: Early Hip Disease. Sat., 12 noon, Mr. Sinclair: Surgical Diseases of the Abdomen.

BIRTHS, MARRIAGES, AND DEATHS.

The charge for inserting announcements of Births, Marriages and Deaths is 9s., which sum should be forwarded with the notice not later than the first post on Tuesday morning, in order to ensure insertion in the current issue.

BIRTH.

CLARK.—On February 13th, at 1, Tynedale Terrace, Benton, Northumberland, to Dr. and Mrs. G. A. Clark, a son.

SUPPLEMENT

TO THE

BRITISH MEDICAL JOURNAL.

LONDON: SATURDAY, MARCH 5TH, 1921.

CONTENTS.

	PAGE		PAGE
THE QUESTION OF STEPS TO BE TAKEN WHEREBY THE ASSOCIATION MAY BECOME IN PART A FEDERATION.		Annual Meeting of the British Medical Association, Newcastle-on-Tyne, 1921: Provisional Programme	65
Report by the Council	55	ASSOCIATION NOTICES:	
DANGEROUS DRUGS REGULATIONS: Communication from the Home Office	63	MOTIONS FOR ANNUAL REPRESENTATIVE MEETING, 1921 ...	63
CURRENT NOTES:		ELECTION OF REPRESENTATIVE BODY, 1921-22 ...	63
THE QUESTION OF FEDERATION	53	BRANCH AND DIVISION MEETINGS TO BE HELD ...	63
COMMITTEES OF INQUIRY	53	MEETINGS OF BRANCHES AND DIVISIONS ...	63
SCHOLARSHIPS AND GRANTS IN AID OF SCIENTIFIC RESEARCH ...	54	INSURANCE:	
DANGEROUS DRUGS REGULATIONS	54	CORRESPONDENCE	66
WORK OF THE PUBLIC HEALTH COMMITTEE	54	INSURANCE COMMITTEES	66
COMPENSATION FOR LOSS OF PUBLIC HEALTH APPOINTMENT... ...	54	LOCAL MEDICAL AND PANEL COMMITTEES	67
EARL HAIG'S FUND FOR OFFICERS AND EX-SERVICE MEN	54	NAVAL AND MILITARY APPOINTMENTS	67
MILEAGE FOR CORONERS' INQUESTS	54	DIARY OF SOCIETIES AND LECTURES	68
CERTIFICATION UNDER THE WORKMEN'S COMPENSATION ACT... ...	54	ASSOCIATION INTELLIGENCE	68
		APPOINTMENTS...	68
		BIRTHS, MARRIAGES, AND DEATHS	68

SPECIAL NOTICE TO MEMBERS.

As the subject matter of the Report of the Council contained herein will require to be dealt with by early meetings of the Divisions, this "Supplement" should be carefully preserved and taken to the Division meeting.

British Medical Association.

CURRENT NOTES.

Question of the Association Becoming in Part a Federation.

As will be seen from the report by the Council printed in this SUPPLEMENT, an interesting stage has been reached in providing the powers whereby the British Medical Association could, if and so far as might be desired, become in part a federation. It will be remembered that this question has several times been raised in connexion with some of the Australian Branches since 1895 onwards, and also more recently in connexion with Ireland. It was first raised in the Representative Body, in connexion with sectional medical bodies at home, by the Brighton Division in 1914.

The present report marks a new epoch in the history of the Association. It provides machinery whereby the Association could, if and when so desired, admit into close and formal co-operation with itself, not only Oversea Branches or groups of such Branches which consider that this would be the best way of securing that full autonomy which several Oversea Branches have asked for, but also sectional medical societies at home with which the Association has been constantly working in co-operation. As regards the Oversea Branches, the Council naturally prefers, as closest and most intimate, the existing relationship of the Oversea Branches and Federal Committees to the parent body. Thus the Council would not at all, of its own accord, propose that any Branch or Federal Committee should take steps, even preliminary to federation with the Association, whereby the Branch or Committee would cease to be a Branch or Committee of the Association. None the less, the Council recognizes that in special circumstances a Branch or group might possibly find this a good plan, as perhaps best giving that full and free self-government which some of the Oversea Branches have intimated to the Council that the interests of their work might require. If the new Articles and By-laws are adopted by the Divisions and Representative Body, and any Oversea Branch should in fact decide to take advantage of the new facilities and therefore cease to be a Branch of the Association in the ordinary sense, the Association would of course extend to it a hearty welcome as an affiliating body, and loyally do its utmost to give it the fullest and most helpful co-operation. As regards the

home societies with which the Association has in the past co-operated, it is impossible to say how many of these would take the opportunity thus provided, but at any rate if the new Articles and By-laws go through, the Association will be able to offer to bodies with whom it wishes to work and who wish to work with it, a formal status and relationship which must materially change, and the Council believes strengthen, the position of the Association.

There is a special point to which attention was drawn in the February meeting of the Council which should receive the closest attention of those who are interested in the work of the Association. The Annual Representative Meeting, Cambridge, agreed that the Articles and By-laws to provide facilities for possible federation arrangements should be so worded as to make it possible for the Association to offer federation not only to medical bodies but to bodies allied in scope and work though not purely medical. It is very desirable that the Divisions should consider seriously, before these new Articles and By-laws are adopted, whether they wish the Association to place itself in a position to become a federation of medical bodies alone, or a mixed federation of medical bodies and bodies whose scope and work have an intimate medical bearing. This aspect is dealt with in paras. 1, 4 (b), 10, and 11 of the report, draft Articles 6 and 7, and By-law 10.

Committees of Inquiry.

Evidence was given by the British Medical Association at a meeting on February 23rd of the Committee appointed by the Minister of Health, under the chairmanship of Viscount Cave, to inquire into the financial position of voluntary hospitals.

The Association has arranged to give evidence also before the Departmental Committee—over which the Earl of Athlone, Chairman of the Middlesex Hospital, is presiding—which was appointed "to investigate the needs of medical practitioners and other graduates for further education in medicine in London, and to submit proposals for a practicable scheme for meeting them." Three representatives of the Association have been appointed to deal with the matter from three different aspects. The President, the Right Hon. Sir T. Clifford Allbutt, will give evidence from the standpoint of the teacher, Dr. C. O. Hawthorne will represent the point of view of practitioners who feel the need of post-graduate work, and Mr. R. J. Willan will speak from the standpoint of the organizer of post-graduate courses.

Scholarships and Grants in Aid of Scientific Research.

It has been the custom of the Council of the British Medical Association to award annually a number of Scholarships and Grants in aid of scientific research. The Scholarships include an Ernest Hart Memorial Scholarship of the value of £200 per annum, and three Research Scholarships each of the value of £150 per annum. The Science Grants amount, in the aggregate, to £350 per annum. The Council is now prepared to receive applications for the Association's Scholarships and Grants for 1921, the awards for which will be made in July next. Forms for the purpose can be obtained from the Medical Secretary, 429, Strand, W.C.2. Further particulars will appear in an early issue.

Dangerous Drugs Regulations.

In the Parliamentary Notes in this week's JOURNAL are printed the statements made in the House of Commons by the Home Secretary regarding the advice given to him by various medical bodies. It will be seen that Mr. Shortt stated that the draft had been submitted last November to the Royal Colleges of Physicians and Surgeons, and to the General Medical Council, and subject to certain minor suggestions had been approved by these bodies, whereas the Pharmaceutical Society of Great Britain had contended that the proposal to prohibit the sale of drugs to the public except on a medical prescription was *ultra vires*. We recorded in a Current Note last week that the British Medical Association, in conjunction with the British Dental Association, the Pharmaceutical Society of Great Britain, and other bodies concerned, was urging the Home Secretary to receive a deputation and appoint a small expert committee to advise him on the redrafting of the Dangerous Drugs Regulations. As will be seen from the letter printed in the SUPPLEMENT at p. 63, the Secretary of State has declined to take this course, but suggests that each of the bodies concerned should confer separately with representatives of the Home Office. The signatories of the joint letter are meeting on Thursday to consider parliamentary action.

Work of the Public Health Committee.

The Public Health Committee at its last meeting dealt with a difficulty which has arisen in connexion with the fees payable to tuberculosis officers acting as referees to the Ministry of Pensions in connexion with the filling up of form M.R.1, and received a report that in the near future the Ministry of Pensions, in conjunction with the Ministry of Health, proposed to pay public health authorities a lump sum in respect of this work, calculated on the average cost of the work done in the past, instead of paying by fee as formerly. The Committee has asked the Ministry of Pensions to take all possible steps to ensure that this sum of money should be paid to the tuberculosis officers in addition to their official salaries. The Committee at the same time considered a proposal by the Ministry of Pensions to pay tuberculosis officers from January 1st, 1921, until the new scheme of payment comes into force, the sum of 2s. 6d. for certifying to local Pensions Committees that a pensioner whom they have been called upon to examine is or is not able to work. The Committee has informed the Ministry that it will advise tuberculosis officers to accept this fee provided that the certificate is confined to a mere statement that the man is or is not able to work. Further consideration was given to the position as regards security of tenure of medical officers of health, as the Order designed to bring this about has not yet been made effective, and it was decided to recommend the Council to authorize the Committee to draft a bill for the purpose of obtaining security of tenure. Sir Philip Magnus, M.P., has been asked to inquire why the Order giving a modified security has not yet been issued by the Ministry of Health, and he has put down a question in the House. In connexion with mileage for public vaccinators the Committee is co-operating with the Association of Public Vaccinators in an effort to draw up a model scale of mileage for this service.

Compensation for Loss of Public Health Appointment.

The Council has approved the recommendation of the Public Health Committee in regard to the position of part-time medical officers of health who have been, or may be,

dispossessed of their appointments either by absorption of area or change of boundary. The Committee reported that in its opinion an effort should be made to obtain for such officers by way of compensation a sum calculated on the following basis:

For each year of service, 1/60th of the average salary for the last five years, plus:	
For 20 years' service and upwards	... 10/60ths additional
.. 15 years' service but under 20	... 7/60ths ..
.. 10 15	... 5/60ths ..
.. 5 10	... 3/60ths ..
Under 5 years' service 1/60th ..

The Association, when requested by any medical officer of health concerned, will bring this suggested scale to the notice of any local authority in which changes of the kind mentioned are proposed.

Earl Haig's Fund for Officers and ex-Service Men.

The Council at its meeting on February 16th considered a suggestion from the Oxford Division that it should "organize an attempt whereby every medical man in this country should be asked for a minimum donation or subscription of £1 ls. to this Fund." The Council came to the conclusion that as many medical men had already subscribed to this Fund individually, and had associated themselves with appeals in various parts of the country, it would not be advisable for the Council to take any action. But the Council warmly commends the example of the Oxford Division to the other Divisions and Branches of the Association. The Oxford Division took action in November, and reports that its resolution in favour of the Fund was taken up with great enthusiasm, and that since that time a cheque for £101 has been sent to Earl Haig's Fund.

Mileage for Coroners' Inquests.

In a Current Note published in the SUPPLEMENT of September 18th, 1920, p. 73, the question of travelling expenses in connexion with coroners' inquests was discussed, and it was stated that the Council of the County of Montgomery had agreed that travelling expenses on the approved county scale should be allowed to medical witnesses at coroners' inquests. The Medical Secretary has now addressed a letter to the clerks of county councils throughout England and Wales calling attention to the fact that under the Coroners Act a coroner has no power to pay travelling expenses to medical witnesses. The letter goes on to point out that even before the war the fees allowed by the Act for performing *post-mortem* examinations and attending at inquests were inadequate; they are now absurdly small, and the Association is pressing the Home Office to bring in an amending Act to meet this and other important points. In the meanwhile, however, the Association feels that those medical men who are so situated that they have to spend much time in travelling to do *post-mortem* examinations and attend inquests are at a special disadvantage which can and ought to be remedied at once. The letter concludes by expressing the hope that the council addressed will take the matter into consideration with a view to following the precedent set by the Montgomeryshire County Council.

Certification under the Workmen's Compensation Act.

From letters received by the Medical Department it appears that it is not at all uncommon for employers who require a certificate of disability from an injured workman in connexion with the Workmen's Compensation Act to send the man to the doctor hoping either that the doctor will not raise the question of a fee or that if he does he will get it out of the patient. For the benefit of members of the Association the Medico-Political Committee has directed that attention shall be called to Paragraph 14 of Schedule 1 of the Workmen's Compensation Act, 1906, which governs the position, and runs as follows:

Any workman receiving weekly payments under this Act shall, if so required by the employer, from time to time submit himself for examination by a duly qualified medical practitioner provided and paid by the employer.

Matters Referred to Divisions.

THE QUESTION OF STEPS TO BE TAKEN

WHEREBY

THE ASSOCIATION MAY BECOME IN
PART A FEDERATION.REPORT OF COUNCIL TO DIVISIONS AND
REPRESENTATIVE BODY.

INSTRUCTION OF A.R.M. 1920.

1. On consideration of the report and recommendations of the Council, 1919-20, (*B.M.J.* Supplement, April 24th, 1920), as to the possibility and desirability of taking further powers under the constitution of the Association whereby it might become in part a federation of medical bodies, the Annual Representative Meeting, Cambridge, 1920, passed the following resolution:—

"44. Resolved: That the Association take steps to obtain further powers under its constitution, on the lines indicated in the joint opinion of Counsel (Messrs. C. E. E. Jenkins, K.C., and T. R. Colquhoun Dill), dated March 6th, 1920 (see *B.M.J.* Supplement, April 24th, 1920, page 139), whereby the Association may, without abandoning its present position as an Association of individual members of the medical profession, become in addition a federation of medical bodies, provided that it be an instruction to the Council:—

(1) To arrange for there being held at an early date a conference of representatives of the Oversea Branches, especially the Branches in the Dominions, with representatives of the Association at home and with representatives of other bodies, if any, who in the opinion of the Council should be invited to such a conference, with a view to arriving, if possible, at a full agreement as to what should be the lines of the proposed new Articles and By-laws.

(2) To report further as soon as practicable to the Representative Body on the subject, with, if possible, such draft alterations of the Articles and By-laws as the Council may suggest with a view to taking further powers under the constitution of the Association in the way proposed.

(3) To arrange that the draft new Articles and By-laws shall *inter alia*:—

(a) Define the classes of organisations to be admissible, whether directly or by means of nominees, to membership of the Association. Such classes to include any portion of the Association which may incorporate itself separately, but also desire admission on the new basis; and to include also medical bodies outside the Association, and bodies representative of the allied professions, anywhere within the Empire.

(b) Assign to the Representative Body the settlement of the general conditions of such membership, including decision as to what shall be the minimum numerical backing within a body seeking to become such member of the Association, which shall render a request for such membership eligible for consideration.

(c) Assign to the Council the duty of submitting to the Representative Body, with a view to such membership, the name of any body proposing, or proposed by the Council, to become such member of the Association.

(d) Assign to the Representative Body the decision as to whether any individual body applying shall be admitted as such member of the Association, and if so, upon what special conditions, if any, in the individual case."

2. These instructions were referred at once by the Council to the Organisation Committee, and by the latter to the Scrutiny Sub-Committee which, under the chairmanship of Sir Jenner Verrall, LL.D., has been making a detailed scrutiny of the constitution and machinery of the Association (see *B.M.J.* Supplement, April 24th, 1920, page 111, para. 64).

3. In consultation with the legal advisers of the Association, the Scrutiny Sub-Committee went into the whole question of steps for federation facilities. Subsequently, on the report of the Organisation Committee, the Council has gone carefully into the matter.

CERTAIN BROAD PRINCIPLES.

4. As a result of several consultations with Counsel certain broad principles emerged:—

(a) That the status, objects and desires of bodies seeking affiliation might be expected to vary so widely as to make it undesirable to load the Articles and By-laws with the details necessary to meet every case that might arise. The proposed alterations in the Articles and By-laws should therefore place on the Representative Body, on receiving a report from the Council, the duty of deciding either to accept or refuse an application for affiliation, and of settling the terms upon which the application (if entertained) shall be granted, and the rights which shall be conceded.

(b) That the alterations made in the Articles and By-laws should be so general and wide in their scope as to give the Representative Body power to provide for the closest possible relation with purely medical bodies, designated in this report "Class (A)" bodies, such as the Oversea Branches, and on the other hand for a much looser or less intimate relationship with bodies not purely medical, designated in this report "Class (B)" bodies. It is believed the former object will be found to be fully provided for; the latter will depend entirely on the decisions of the Representative Body itself as to the terms and conditions it proposes in respect of any bodies applying.

(c) That from a legal point of view it is necessary to distinguish "corporate" bodies (*i.e.* bodies which have an existence in a legal sense) from "unincorporated" bodies (which have no such existence). The former can definitely become affiliated members of the Association; the latter can only nominate persons to act for them as affiliated members. Hence the separation into Corporate and Nominated members.

5. The Council has carefully considered the question whether Minute 44 of the Representative Meeting at Cambridge contemplated not only possible affiliation of outside bodies to the Association as a whole, but possible affiliation of local bodies outside the Association to Divisions or Branches of the Association. However this may be, the Council is legally advised that outside bodies could not be affiliated to, *i.e.*, be members of, a Division or Branch unless they were members of the Association, and that there would be great difficulty in giving an outside body actual membership of the Division or Branch, because neither a Division nor a Branch is in itself a "corporate" body, and not being such cannot legally take into affiliation another body. Provision is made, however, for Divisions and Branches to co-opt or appoint such persons as they desire to their Executive Committees and Branch Councils.

PROVISION MADE IN THE APPENDED ARTICLES AND BY-LAWS.

Possible Privileges of Affiliated Bodies.

6. The Council is legally advised that provision for representation of affiliated bodies at General Meetings of the Association is necessary under the Companies Acts. This has accordingly been provided for.

7. The draft amended Articles and By-laws proposed by the Council are appended. In detail it will be found that these give the Representative Body full discretion as to which (for example) of the following privileges it will grant to any bodies seeking one or other kind of affiliation:—

(i.) *As regards the Representative Body.*

Representation.
Right to bring forward motions.
Right to vote.
Right to attend merely, or be heard.

(ii.) *As regards the Council.*

Representation.
Right to bring forward motions.
Right to vote.

(iii.) *As regards Standing Committees.*

Representation.
Right to bring forward motions.
Right to vote.

(iv.) *As regards "British Medical Journal."*

Use of for notices and reports of meetings.
Refusal of advertisements.
Use of "Important Notices"
Supply of *British Medical Journal*

8. (a) One privilege not conceded is the right to vote in a Referendum. Since on a Referendum every individual

vote is reckoned in the total vote, it is the opinion of the Council that the possibility of an affiliated body with a large membership becoming possessed of what might be a casting vote is one not to be entertained.

(b) It is not proposed that the Association should pay the expenses of a representative sent by an affiliated body to an Association meeting.

9. It will be seen that in the draft Articles and By-Laws submitted, the possible privileges to be accorded to an affiliating body are referred to only in general terms. The Council on legal advice does not propose to attempt to define or enumerate in the Articles and By-laws the privileges which, or some of which, might be given by the Association. To make such an enumeration in the Articles and By-laws would make the Articles and By-laws unduly complicated and unwieldy, and would fetter the procedure of the Association.

Proposed Rules of Representative Body.

10. The Council proposes, in order to carry out the instruction of the Annual Representative Meeting at Cambridge, that under the provisions contained in draft Article 8 and By-law 10 (5), the Representative Body shall adopt rules, which it can modify from time to time, as to the possible privileges of a body affiliating with the Association, and as to the terms and conditions of admission to affiliation. The Council proposes that in the rules there shall be stated all the privileges which, or some of which, the Association might possibly give to a body affiliating to it and that the question of any reciprocal privileges be also dealt with therein. The Council further proposes that the Representative Body shall in the rules lay down, in general terms, for its own guidance and that of the Council, the privileges which may be accorded to a Class (A), and to a Class (B) body, respectively. Thus in the case of a Class (A), i.e., a wholly medical body, the relationship would or might be, according as mutually agreed in the individual case, of the closest possible nature consistent with the stability of the Association, and in the case of a Class (B), i.e., a non-medical body, probably much less close.

11. The rules will however, the Council proposes, leave to the Representative Body the fullest possible power to discriminate, and to decide in the individual case, what privileges shall or shall not be given, and on what terms. The rules will also regulate the procedure of the Council, and of the Representative Body itself, as regards possible applications for affiliations and as regards the actual arrangements effecting affiliation.

12. Pursuant to Minute 44 (1) of the Cambridge Representative Meeting, the Council is calling, to meet on July 5th, at the Head Office of the Association, a Conference of representatives of the Oversea bodies and of Ireland, including the Representatives and Members of Council for those areas, with representatives of the Council. The Council does not consider the time yet opportune for a Conference with other bodies such as are referred to in Minute 44 (1) of the A.R.M., 1920. The Council proposes to submit to the Divisions, to the Conference on July 5th, and to the Representative Meeting at Newcastle, draft rules of the Representative Body to govern affiliation.

Question of Financial or other Responsibility.

13. The Council is advised by Counsel that such affiliation as is proposed, of an outside body to the Association, would involve neither body in financial or other responsibility for actions of the other.

Application for Affiliation.

14. Any application will be dealt with, in the first instance, by the Council, and the Council will report to the Representative Body. The Representative Body will thus not deal with any such application except on report by the Council. These general provisions will, the Council intends, be supplemented by the rules of the Representative Body referred to in paragraph 10 above.

Termination of Affiliation.

15. Either body would be free to terminate the affiliation on notice duly given, and including, in the case of the Association, adoption of a resolution to that effect by the Representative Body by a majority of at least two-thirds of the votes thereon, after opportunity given to the body concerned to be heard on the subject at the Representative Meeting dealing with it.

GENERAL MEETINGS FOR ALTERATION OF ARTICLES.

16. If the representatives of the Oversea bodies and Ireland attending the Conference on July 5th, express their approval of the suggested alterations of the Articles and By-laws, the Council proposes that these be approved and adopted by the Annual Representative Meeting at Newcastle, and by General Meetings to be held on July 19th in Newcastle and August 3rd in London, and thus be made operative at once.

17. To be in time for consideration by the Conference and Annual Representative Meeting, any proposal by a Division, Branch or Federal Committee for amendment of the draft Articles and By-laws now submitted by the Council would require to be published in the *British Medical Journal* not later than May 14th, and should therefore be received at the Head Office not later than April 30th.

18. The Council recommends :

RECOMMENDATION.

That the Annual Representative Meeting, 1921, having considered the opinion of the representatives of the Oversea bodies and Ireland, approve and adopt the draft Articles and By-laws submitted by the Council (see Appendix), with a view to placing the Association in a position to become in part (if and as found desirable) a federation; and instruct the Council to submit those Articles to Extraordinary General Meetings of the Association on July 19th, and (if adopted by the Extraordinary General Meeting on July 19th) August 3rd, 1921, for final adoption as Articles of the Association.

APPENDIX.

(DRAFT) ARTICLES AND BY-LAWS SUBMITTED BY COUNCIL TO DIVISIONS AND REPRESENTATIVE BODY TO PLACE THE ASSOCIATION IN A POSITION TO BECOME IN PART A FEDERATION.

(NOTE.—Articles and By-laws not mentioned in this Appendix are intended to remain as at present, but to be re-numbered (including cross references) where necessary consequentially. References to lineage of existing Articles and By-laws are to those of the booklet print of the Memorandum, Articles and By-laws.)

New Articles 3-8 to take the place of existing Articles 3 and 4.

MEMBERSHIP.

3. The Association shall consist of members of the following classes, viz:—

- (1) Individual Members.
- (2) Corporate Members.
- (3) Nominated Members.

Individual Members.

(i.) *Ordinary.*

4. The following individuals shall be eligible as ordinary members of the Association, viz:—

(a) Any medical practitioner registered in the United Kingdom under the Medical Acts;

(b) Any medical practitioner who does not reside within the area of any Branch of the Association and who, though not so registered, is possessed of any of the qualifications described in Schedule (A) of the Medical Act, 1858; and

(c) Any medical practitioner residing within the area of any Branch of the Association situate in any part of the British Empire, other than the United Kingdom, who is so registered or possesses such medical qualification as shall, subject to the By-laws, be prescribed by the rules of the said Branch.

(ii.) *Honorary and Extraordinary.*

5. (1) The Association shall have power to elect as honorary members such individuals, and in such manner, as the By-laws may provide, and to admit members so elected to such privileges (other than that of voting as members of the Association) as may from time to time be conferred on them by or under the By-laws.

(2) Each Division or Branch shall have power to admit to certain of the privileges of membership of such

Division or Branch, other than that of voting: (a) individual members of the Association who are not entitled to be ordinary members of such Division or Branch; and (b) individuals being members of the medical profession, or distinguished in other sciences, who are not eligible as ordinary members of the Association.

Corporate Members.

6. The following corporate bodies shall be entitled to be corporate members of the Association, viz., any association or body of persons which:—

(a) Is incorporated under the laws of the United Kingdom or of any other part of the British Empire; and

(b) Has for one of its objects the promotion of medical or any allied science or of the welfare of the medical or any allied profession; and

(c) Is approved as a corporate member by the Representative Body hereinafter mentioned.

Nominated Members.

7. A nominated member of the Association shall be an individual nominated for that purpose by any unincorporate association or body of persons which—

(a) Has been formed within the United Kingdom or any other part of the British Empire; and

(b) Has for one of its objects the promotion of medical or any allied science or of the welfare of the medical or any allied profession; and

(c) Is approved by the Representative Body for the purpose of making such nomination. Any such association or body is hereinafter referred to as a "nominating body."

Members Generally.

8. Subject as hereinbefore provided, the conditions of membership shall be such as may from time to time be prescribed by the By-laws, and in particular the By-laws may prescribe modes of application for membership and the designations under which individuals shall be admitted to the privileges of extraordinary membership and the nature of such privileges and the conditions of admission thereto, and the conditions upon which any approval may be given by the Representative Body in the case of corporate members and nominating bodies.

[Existing Articles 3 and 4.

"Eligibility.

"3. Any medical practitioner registered in the United Kingdom under the Medical Acts, and any medical practitioner who does not reside within the area of any Branch of the Association and who, though not so registered, is possessed of any of the qualifications described in Schedule (A) of the Medical Act, 1858, and any medical practitioner residing within the area of any Branch of the Association situate in any part of the British Empire other than the United Kingdom, who is so registered or possesses such medical qualification as shall, subject to the By-laws, be prescribed by the rules of the said Branch, shall be eligible as an ordinary member of the Association. Subject as aforesaid the mode and conditions of election to membership shall from time to time be determined by or in accordance with the By-laws."

"Honorary and Extraordinary Members

"4. (1) The Association shall have power to elect as honorary members such persons, and in such manner as the By-laws may provide, and to admit members so elected to such privileges (other than that of voting as members of the Association) as may from time to time be conferred on them by or under the By-laws.

"(2) Each Division or Branch shall have power to admit to certain of the privileges of membership of such Division or Branch, other than that of voting: (a) members of the Association who are not entitled to be ordinary members of such Division or Branch; and (b) members of the medical profession, or persons distinguished in other sciences, who are not eligible as ordinary members of the Association. The By-laws may prescribe the designation under which persons shall be admitted to such privileges, the nature of the privileges to be conferred upon them and the conditions of admission thereto."

Article 9.

Existing Article 5 (to be Article 9) to be amended by insertion after "amount," in line 3, "or calculated in such manner."

[Existing Article 5.
"Subscriptions.

"5. Save as otherwise provided by the By-laws every member shall pay to the Association a subscription of such amount as may for the time being be prescribed by the By-laws. The said subscription shall be considered due in advance on the 1st of January of each year, or in the case of members elected during the year, at the time of election."

Article 10.

10. Each year's subscription shall, in the case of an individual member, entitle the member to all such privileges of membership as attach to the class of individual members to which he belongs, including that of receiving the Journal for the current year, and, in the case of an ordinary member, to the ordinary privileges of membership of that Division and of that Branch of which he is an ordinary member, and shall in the case of a corporate or nominated member entitle the member or the nominating body to all such privileges as may be prescribed by the conditions upon which such member is admitted to membership.

[Existing Article 6.

"Each year's subscription shall entitle the member to all privileges of membership of the Association, including that of receiving the Journal for the current year, and to the ordinary privileges of membership of that Division and of that Branch of which he is an ordinary member."

Article 11.

Re-Eligibility.

11. No person who shall have been a member of the Association and ceased to be such shall be eligible for re-election until all arrears of subscription (if any) due from such member to the Association at the date when the former membership ceased, shall have been paid, and no individual member whose former membership shall have been terminated by reason of his conviction or expulsion as hereinafter provided shall, without the previous sanction of the Council, be eligible for re-election by any Branch Council.

[Existing Article 7.

"Re-Eligibility.

"7. No person who shall have been a member of the Association and ceased to be such shall be eligible for re-election until he shall have paid all arrears of subscription (if any) due from him to the Association at the date when his former membership ceased, and no person whose former membership shall have been terminated by reason of his conviction or expulsion as hereinafter provided shall, without the previous sanction of the Council, be eligible for re-election by any Branch Council."

Article 12.

Existing Article 8 (to be Article 12) to be amended by substitution of "such" for "his," in line 1.

[Existing Article 8.

"Duration of Membership.

"8. Every member shall remain a member until his membership is terminated in accordance with the provisions hereinafter contained."

Article 13.

Termination of Membership.

13. Membership of the Association may be terminated in any of the following ways, namely:—

(a) In the case of any member, by resignation, subject to such notice as may be prescribed by the By-laws and subject to the provisions of the next succeeding Article

(b) In the case of any member, *ipso facto*, save as hereinafter provided, by default in the payment of subscriptions to the Association for such period as may be prescribed by the By-laws."

(c) In the case of an individual member, *ipso facto* (i.) upon sentence (after conviction in a Court of Justice of any crime) to imprisonment with hard labour without the option of a fine, or to any greater punishment; or (ii.) upon erasure from the Medical Register under Section 29 of the Medical Act of 1858; or (iii.) upon erasure from the Medical Register of any part of the British Empire on the ground of professional misconduct; or (iv.) upon forfeiture through misconduct of the medical qualification (if any) by virtue of which the member shall have been eligible for membership.

(d) In the case of an individual member, by expulsion (after the enquiry and in the manner prescribed in the next succeeding Article) on the ground that the conduct of the member is detrimental to the honour and interests of the medical profession or of the Association or calculated to bring the profession into disrepute, or on the ground that the member has wilfully and persistently refused to comply with the Regulations of the Association, or the rules of any Division or Branch of which he may be a member.

(e) In the case of a corporate member or a nominated member, *ipso facto* upon the passing by the Representative Body of a resolution that it is undesirable that such membership shall continue. Provided that no such resolution shall have effect unless (i.) the resolution is passed at a meeting of the Representative Body of which not less than six months' notice in writing has been given to the member concerned, stating that such resolution will be proposed at that meeting, and (ii.) opportunity has been given to the member concerned to be heard at such meeting, and (iii.) the resolution is carried by a majority of not less than two-thirds of the votes given thereon in the manner prescribed by the By-laws.

[Existing Article 9.

Termination of Membership.

"9. Membership of the Association may be terminated in any of the following ways, namely:—

"(a) By resignation, subject to such notice as may be prescribed by the By-laws and subject to the provisions of the next succeeding Article.

"(b) *Ipso facto*, save as hereinafter provided, by default in the payment of subscriptions to the Association for such period as may be prescribed by the By-laws.

"(c) *Ipso facto* (i.) upon sentence (after conviction in a Court of Justice of any crime) to imprisonment with hard labour without the option of a fine, or to any greater punishment; or (ii.) upon erasure from the Medical Register under Section 29 of the Medical Act of 1858; or (iii.) upon erasure from the Medical Register of any British Colony or Dependency on the ground of professional misconduct; or (iv.) upon forfeiture through misconduct of the medical qualification by virtue of which the member shall have been eligible for membership.

"(d) By expulsion (after the enquiry and in the manner prescribed in the next succeeding Article) on the ground that the conduct of the member is detrimental to the honour and interests of the medical profession or Association or calculated to bring the profession into disrepute, or on the ground that the member has wilfully and persistently refused to comply with the Regulations of the Association or the rules of any Division or Branch of which he may be a Member."]

Article 14.

Heading of existing Article 10 (to be Article 14) to be, instead of "Expulsion," "Expulsion of Individual Members."

Article 15.

Existing Article 11 (to be Article 15) to be amended by inserting, after "The," in line 1, "individual."

[Existing Article 11.

Formation of Divisions and Branches.

"11. The members of the Association shall be formed into separate local bodies styled Divisions and Branches."]

Article 16 (2).

Existing Article 12 (2) (to be Article 16 (2)) to be amended by inserting at the end of the last sentence but one, after the word "thereof," the words:—"The Council shall also have full power to dissolve any Division or Branch."; and by adding at the end of the Article, the words:—"or which it is proposed to dissolve."

[Existing Article 12 (2).

"12. (2) Subject in the case of Divisions and Branches not in the United Kingdom to the provisions of the By-laws, it shall rest with the Council from time to time to determine, recognise, and declare by resolution published in the Journal, what bodies of members shall be Divisions, and what Divisions and groups of Divisions shall be Branches of the Association, and what shall be the local area of each Division, and accordingly the Council shall have full power from time to time to amalgamate, subdivide and modify Divisions and Branches and the local areas thereof. Nevertheless, not less than one month's notice in all cases shall be given (in the manner prescribed by the By-laws) to any Division or Branch in whose boundaries or area any change is proposed."]

Article 18.

Existing Article 14 (to be Article 18) to be amended by inserting after "every," in the first line, "ordinary."

[Existing Article 14.

Membership

"14. Every member whose address as registered for the time being in the books of the Association is at a place situate within the area of any Division shall, *ipso facto*, be an ordinary member of that Division and of no other, and every ordinary member of a Division shall, *ipso facto*, be an ordinary member of the Branch which comprises that Division and of no other."]

Article 29.

Existing Article 25 (to be Article 29) to be amended by deleting the first four lines, and inserting in place thereof:—

Annual Scientific Meetings.

"29. The Council shall at least once a year arrange Meetings or Conferences of the Association either alone or in conjunction with other bodies (attendance at which shall be open to every individual member of the Association, and to such other persons or classes of persons as may from time to time be authorised in that behalf by the Representative Body), for the purpose of receiving" (etc., as at present).

[Existing Article 25.

Annual Scientific Meetings.

"25. The Council shall at least once a year arrange meetings or Conferences, alone or in conjunction with other bodies, which it shall be open to every member of the Association to attend, for the purpose of receiving addresses or other communications relating to the medical or allied sciences, and discussing such subjects pertaining thereto as the Council may think proper, and the Council may arrange to hold such meetings or Conferences in the United Kingdom or abroad. When held in the United Kingdom, one such meeting shall be convened at the same place as the Annual General Meeting of the Association, and in connection, but so as not to conflict therewith. For the more convenient consideration of the matters to be discussed, the Council may provide that they shall be considered in sectional meetings, and the Council shall appoint a President and other officers of such Section as well as readers of any addresses that may be given."]

Article 32.

General Powers (of Representative Body).

32. Subject to the provisions of any statute, the general control and direction of the policy and affairs of the Association shall be vested in a body of Representatives,

styled "the Representative Body," and composed (a) of individual members of the Association elected by the Divisions in the manner prescribed by the By-laws, and (b) of the members of the Council for the time being in office or elected to take office, and (c) of persons (if any) appointed by such corporate members and nominating bodies as may be empowered in that behalf by the conditions of membership affecting them respectively.

[Existing Article 28.

"General Powers.

"28. Subject to the provisions of any statute the general control and direction of the policy and affairs of the Association shall be vested in a body of Representatives styled "the Representative Body" and composed of members of the Association elected by the Divisions in the manner prescribed by the By-laws, and of the members of the Council for the time being in office or elected to take office."]

Article 33 (2).

33. (2.) Except as may be prescribed by the Representative Body, no person who is not a member of that Body shall be entitled to take part in any Representative Meeting.

[Existing Article 29 (2).

"29. (2). No member of the Association who is not a member of the Representative Body shall be entitled to take part in any Representative Meeting."]

Article 34 (2).

Existing Article 30 (2) (to be Article 34 (2)) to be amended by inserting, in the last line but 3, after "Division":—

"or by any corporate member of the Association or nominating body authorised in that behalf by the Representative Body, and shall have been published" (etc., as at present).

[Existing Article 30 (2)

"Resolutions (of Representative Body).

"30. (2). Provided that no resolution of the Representative Body to make any addition to or any amendment, alteration, or repeal of any Regulation or By-law or to make any new Regulation or By-law, shall have any operation unless a proposal to make the same shall have been previously approved and submitted to the Representative Body, either by the Council, or by a Branch, or by a Division, and shall have been published in the *Journal* not less than two months before the Annual Representative Meeting, or one month before the Special Representative Meeting at which such resolution is passed."]

Article 36.

Existing Article 32 (to be Article 36) to be amended by substituting, in line 5, for "members of the Association," "persons"; and by inserting, after "elected," in the same line, "or appointed."

[Existing Article 32.

"Composition (of Council).

32. The Council shall be composed of the President of the Association, the President-Elect, the Past-President, the Chairman of Representative Meetings, the Chairman of Council, the Past-Chairman of Council, and Treasurer *ex officio*, and of members of the Association elected by the bodies, and in the manner prescribed in that behalf by the By-laws."]

Article 42.

Existing Article 38 (to be Article 42) to be amended (1) by inserting, in the second line, after "Council":—" (other than such members, if any, thereof as may be appointed by a corporate member or by a nominating body)"; and (2) by substituting for the second sentence of second paragraph, the following:—

"The expenses, defined as aforesaid, within the United Kingdom, of all individual members attending meetings of Council or of Committees and of all persons invited by the Representative Body or by the Council to attend, and attending, any Conference or meeting, shall be defrayed in like manner."

[Existing Article 38.

"Expenses.

"38.—(1) The expenses, as defined in the By-laws, within the United Kingdom of members of Council and Representatives of Divisions attending any Representative Meeting shall be defrayed out of the general funds of the Association.

"Attendance of Representatives of Divisions for this purpose shall be construed to mean attendance at each session of the Representative Meeting, unless the Council shall be satisfied that good cause existed for absence from any particular session or sessions. The expenses, defined as aforesaid, within the United Kingdom of all members attending meetings of Council or of Committees and of all members authorised by the Representative Body or by the Council to attend, and attending, any Conference shall be defrayed in like manner.

"(2) The Council shall (subject as hereinbefore provided) determine what shall be considered an attendance for the purpose of this Article."]

Article 43.

Existing Article 39 (to be Article 43) to be amended by inserting, after "Division," in last line but one:—

"and of every corporate member and nominating body."

[Existing Article 39.

"Financial and other Reports and Audit.

"39. The Council shall annually prepare a Balance Sheet and Financial Statement of the Association for the past year, an Estimate of the probable income and expenditure of the Association for the coming year, and a Report of the general state and proceedings of the Association for the past year to be presented to the Annual Representative Meeting. Such Balance Sheet and Statement shall be audited by a professional accountant and a copy of the same as audited and also a copy of such Estimate and Report shall be sent to the Secretary of every Branch and Division, and published in the *Journal* not less than two months before the said meeting."]

Article 45.

Existing Article 41 (to be Article 45) to be amended by inserting, in line 4, after "separate," "class or."

[Existing Article 41.

"By-laws.

"41. Save so far as determined by statute or by the Regulations the constitution and mode of government of the Association, the rights and obligations of every member and separate body of members thereof, the appointment, duties, powers, and privileges of all Officers, and of all Councils, Committees, and governing and administrative bodies both of the Association and of every Division and Branch, shall be such as may from time to time be prescribed and determined by or in accordance with the By-laws, and the By-laws may from time to time be added to, amended, altered, or repealed by the Representative Body, subject to the provisions hereinbefore contained with respect to a resolution of that body for the purposes aforesaid."]

By-law 4.

Existing By-law 4 to be amended (i.) By inserting in the heading thereof, after "Membership":—(1) "Individual Members," (ii.) By inserting, in line 1, after "for," "ordinary."

[Existing By-law 4.

"MEMBERSHIP.

Application.

"4. Every candidate for membership of the Association shall apply for election in writing, addressed to the Association, and stating his agreement, if elected, to abide by the Regulations and

By-laws, and the rules of the Division and Branch to which he may at any time belong, and to pay his subscription for the current year.”]

By-law 5 (1).

Existing By-law 5 (1) to be amended (i.) by inserting in line 2, after “election of,” “ordinary”; (ii.) by substituting, in line 9, for the words “a member,” the words “an ordinary member.”

Existing By-law 5 (1).

“*Election by Branches.*

“5. (1) In the case of a Branch in the United Kingdom, the mode of election of members shall be as follows:—Every candidate who resides within the area of a Branch shall forward his application to the Secretary of such Branch. Notice of the proposed election shall be sent by the Branch Secretary to the Association at the Head Office, and to every member of the Branch Council, and the candidate, if not disqualified by any Regulation of the Association, may be elected a member of the Association by the Branch Council at any meeting thereof held not less than seven days (or such longer period as the Branch may by its rules prescribe) after the date of the said notice. A Branch may require that each candidate for election shall furnish a certificate signed by two members (either of the Association, or of the Branch, or of the Division in which he resides, as the rules of the Branch may prescribe) stating that from personal knowledge they consider him a suitable person for election.”]

By-law 6.

Existing By-law 6 to be amended (i.) by inserting, in line 4, after “three,” “individual”; (ii.) by inserting, in last line but 2, after “elected,” “an ordinary.”

[Existing By-law 6.

“*Election by the Council.*

“6. Every candidate who does not reside within the area of any Branch shall forward his application to the Association at the Head Office, together with a certificate signed by three members of the Association stating that from personal knowledge they consider him a suitable person for election. Notice of the proposed election shall be sent by the Association from the Head Office to every member of the Council, and the candidate, if not disqualified by any of the Regulations or the By-laws, may be elected a member of the Association by the Council at any Meeting thereof held not less than one month after the date of the said notice.”]

New By-law 10, to follow existing By-law 9.

(2) *Corporate and Nominated Members.*

(1) Every application by an association or body of persons (in this By-law called “the applicant body”) desiring to become a corporate member or to be empowered to nominate a nominated member, shall be in writing signed by the Secretary or other responsible officer of the applicant body and transmitted to the Association at the Head Office.

(2) Every such application shall be considered by the Council at a meeting of which a notice, specifying that such consideration will form part of the business thereat, shall be sent to every member of the Council. Such consideration shall include a consideration of the Memorandum of Association or instrument of foundation and the regulations of the applicant body, and of the question whether the application appears to be within the powers of and to be made with the concurrence of a substantial number of the members of that body.

(3) The Council shall report to the Representative Body upon all applications considered by the Council, and no application shall be considered by the Representative Body except upon the report of the Council.

(4) The Representative Body may in each case reported on by the Council give or withhold the approval required by the Regulations, and shall not be bound to state any reasons for any such action.

(5) Where such approval is given, the Representative Body shall prescribe the conditions upon which the

membership applied for is to be permitted, and such conditions may include conditions fixing the amount of the subscription, and regulating, restricting, or negating rights of representation upon the Representative Body and upon the Council, and upon any Standing Committee, rights of attendance at meetings of the Representative Body and at scientific meetings of the Association, and such other conditions as the Representative Body may consider proper in each particular case.

By-law 11.

Annual List of Members.

11. In the month of May in each year a list of members of the Association shall be prepared and published, stating the names and addresses of such members as shown by the register (to be kept by the Association at the Head Office) of members of the Association on April 30th of that year. The persons named in the said list as ordinary members of any Division or Branch and no others (etc., as at present).

[Existing By-law 10.

“*Annual List of Members.*

“10. In the month of May in each year a list of members of the Association shall be prepared and published stating the names and addresses of the ordinary members of each Division and Branch as shown by the register (to be kept by the Association at the Head Office) of members of the Association on April 30th of that year, and those named in the said list as members of any Division or Branch and no others shall be deemed to be the ordinary members of such Division and Branch at the date of the publication of such list for all the purposes of the Regulations and the By-laws. Such list is hereinafter referred to as the ‘annual list.’”]

By-law 12.

Amount (of Subscriptions).

12. (1) On and after the 1st of January, 1922, and except as hereinafter provided, the annual subscription to the Association shall be:—

(a) For an ordinary member resident in any part of the United Kingdom—three guineas.

(b) For an ordinary member resident elsewhere—two guineas.

(c) For a corporate member or a nominated member—such sum whether by way of capitation or otherwise as the Representative Body may fix in each particular case.

Provided as follows:—

(i.) In the case of an ordinary member resident in the United Kingdom and admitted before the expiration of two years from the date of his registration under the Medical Acts, the annual subscription shall be one-and-a-half guineas until the 31st December next occurring after the expiration of the period of four years from the date of such registration.

(ii.) A member admitted on or after the 1st of July in any year shall pay half the current subscription for that year.

(2) For the purposes of this By-law an ordinary member shall be deemed to reside in that place in which his ordinary place of abode is situate at the time at which according to the Regulations his subscription is considered due.

[Existing By-law 11.

“*Subscriptions: Amount.*

“11. (1) On and after the 1st of January, 1921, and except as hereinafter provided, the Annual Subscription to the Association shall be:—

“(a) For a member resident in any part of the United Kingdom—three guineas.

“(b) For a member resident elsewhere—two guineas.

Provided as follows:—

“(c) In the case of a member resident in the United Kingdom and admitted before the expiration of two years from the date of his registration under the Medical Acts, the annual subscription shall be one-and-a-half guineas until the 31st of December next occurring after the expiration of the period of four years from the date of such registration.

“(d) A member admitted on or after the 1st of July in any year shall pay half his current subscription for that year.

"(2) For the purposes of this By-law a member shall be deemed to reside in that place in which his ordinary place of abode is situate at the time at which according to the Regulations his subscription is considered due."

By-law 14.

Arrears of Subscription, Cessation of Membership.

14. (1) If the subscription of a member for any year shall not have been paid on or before the 31st of December in that year, such member shall *ipso facto* (but save as otherwise provided by the Regulations and without prejudice to his liability to the Association) cease to be a member as from that day. Provided that upon payment before the 31st day of March in the succeeding year of all subscriptions due from such member he shall, if eligible, be restored to membership without re-election or new application.

(2) No member shall (except in case of a cesser of membership under the provisions of Clause (c), (d) or (e) of the 13th Article of Association or under the previous provision of this By-law) cease to be a member without having given three months' previous notice in writing of such member's intention in that behalf to the Association at the Head Office, and having paid all arrears of subscriptions (if any) due.

[Existing By-law 13.

Arrears of Subscription, Cessation of Membership.

" 13. (1) If the subscription of a member for any year shall not have been paid on or before the 31st of December in that year, he shall *ipso facto* (but save as otherwise provided by the Regulations and without prejudice to his liability to the Association) cease to be a member as from that day. Provided that upon payment before the 31st day of March in the succeeding year of all subscriptions due from him he shall, if eligible, be restored to membership without re-election.

(2) No member shall (except in case of his expulsion, or of his ceasing to be a member under the provisions of Clause (c) of the 9th Article of Association or under the previous provision of this By-law) cease to be a member without having given three months' previous notice in writing of his intention in that behalf to the Association at the Head Office, and having paid all arrears of subscriptions (if any) due from him."

By-law 17.

Existing By-law 16 (to be By-law 17) to be amended by substituting in line 3 and last but one, for "members" "persons."

[Existing By-law 16.

Local Management: Branches.

" 16. The management of the affairs of each Branch shall, save as otherwise provided in the By-laws, be vested in a Branch Council, composed of the following members:—

" (a) Those members of the Council who are elected (as hereinafter provided) by the Branch or by any group of Branches to which the Branch belongs or (wholly or in part) by Representatives of Constituencies comprised in the Branch.

" (b) The members elected to represent on the Representative Body the Divisions comprised in the Branch.

" (c) Such Officers of the Branch as the Branch shall by its rules declare to be members *ex officio* of the Branch Council.

" (d) Such members (if any) of any Local Medical Committee formed under the National Insurance Act, 1911, and such medical members (if any) of any Insurance Committee constituted under that Act, being (in either case) ordinary members of the Association resident within the area of the Branch as the Branch may appoint or the Branch Council may co-opt to be members of the Branch Council.

" (e) Such other members as the Branch may by its rules decide."

By-law 20.

Existing By-law 19 (to be By-law 20) to be amended by substituting in line 4 and last line but one, for "members", "persons."

[Existing By-law 19.

Local Management: Divisions.

" 19. The management of the affairs of each Division shall, save as otherwise provided in the By-laws, be vested in an Executive Committee composed of the following members:—

" (a) The member or members representing the Division on the Representative Body;

" (b) The member or members representing the Division on the Branch Council;

" (c) Such Officers of the Division as the Division shall by its rules declare to be members *ex officio* of the Executive Committee.

" (d) Such members (if any) of any Local Medical Committee formed under the National Insurance Act, 1911, and such medical members (if any) of any Insurance Committee constituted under that Act, being (in either case) ordinary members of the Association resident within the area of the Division as the Division may appoint or the Executive Committee may co-opt to be members of the Executive Committee.

" (e) Such other members elected by the Division as the Division may determine."

By-law 30.

Existing By-law 29 (to be By-law 30) to be amended by substituting, in line 4, for "members," "persons entitled to vote."

[Existing By-law 29.

Quorum (at General Meetings).

" 29. Except as hereinafter provided in this By-law no business shall be transacted in any General Meeting unless there be present a quorum of not less than 100 members. If within one hour from the time appointed for the meeting such quorum be not present, the Meeting, if convened upon the requisition of members, shall be dissolved. In any other case it shall stand adjourned to the same day in the following week, at the same time and place, and if at such adjourned meeting a quorum be not present those present shall be deemed to be a quorum."

New By-law 32. to follow existing By-law 30.

Persons entitled to Attend and Vote (at General Meetings).

32. (1) At every General Meeting of the Association the following persons shall be entitled to be present, namely:—

Every individual member of the Association.

Every nominated member of the Association.

One person to represent each corporate member of the Association, provided that such person shall be an official of such corporate member duly authorised by resolution of the corporation to act as such representative.

(2) Every such person (other than an honorary or extraordinary member) shall be entitled to vote at such Meeting.

By-law 33.

Voting at General Meetings.

33. At a General Meeting, unless a poll is demanded in writing by at least five persons present and entitled to vote, a declaration by the Chairman that a resolution has been carried, or carried by a particular majority, or lost or not carried by a particular majority, and an entry to that effect in the book of proceedings of the Association, shall be sufficient evidence of the fact without proof of the number or proportion of the votes recorded in favour of or against any such resolution. If a poll be demanded by five or more such persons, the same shall be taken, in such manner and either at once or after an interval or adjournment, as the Chairman directs, and the result of such poll shall be deemed to be the resolution of the Association in General Meeting. On a show of hands every such person shall have one vote, and upon a poll every such person shall have one vote. Votes must be given personally. In case of any equality of votes at any General Meeting, the Chairman shall have a second or

[Existing By-law 31.

"Voting at General Meetings.

"31. At a General Meeting, unless a poll is demanded in writing by at least five members, a declaration by the Chairman that a resolution has been carried, or carried by a particular majority, or lost or not carried by a particular majority, and an entry to that effect in the book of proceedings of the Association shall be sufficient evidence of the fact without proof of the number or proportion of the votes recorded in favour of or against any such resolution. If a poll be demanded by five members or more, the same shall be taken in such manner and either at once or after an interval or adjournment, as the Chairman directs, and the result of such poll shall be deemed to be the resolution of the Association in General Meeting. On a show of hands every member present in person shall have one vote, and upon a poll every member present in person shall have one vote. Votes must be given personally. In case of any equality of votes at any General Meeting, the Chairman shall have a second or casting vote."

By-law 44 (1).

Voting (in Representative Meetings).

44. (1) In any Representative Meeting, only Representatives of Constituencies and such representatives (if any) of corporate members and nominating bodies as may be empowered in that behalf by the Representative Body, and members of Council representing the Navy, Air Force, Army, and Indian Medical Services, shall be entitled to vote.

By-law 44 (2) and (3).

Existing By-law 42 (2) (to be By-law 44 (2)) to be amended by inserting, after "Representatives," in line 2, "of Constituencies."

Existing By-law 42 (3) (to be By-law 44 (3)) to be amended by inserting, after "Services," in last line but 1, "and representatives (if any) of corporate members and nominating bodies."

[Existing By-law 42.

"Voting.

"42. (1) In any Representative Meeting only Representatives of Constituencies and members of Council representing the Navy, Air Force, Army, and Indian Medical Services shall be entitled to vote.

"(2) Voting shall be by show of hands, unless before such vote is taken twenty Representatives present request that the vote be taken by card.

"(3) Where a vote is taken by card the Representative of each Constituency shall be entitled (or in the case of a Constituency electing two or more Representatives, such of those Representatives as are present shall together be entitled) to record a total number of votes equal to the number of members in that Constituency according to the annual list then in force; and where two or more Representatives of a Constituency are present the total number of votes of that Constituency shall be divided equally between those Representatives, fractions of votes being ignored. Members of Council representing the Navy, Air Force, Army, and Indian Medical Services shall not take part in a vote taken by card.

"(4) In speaking and voting upon any matter, the Representative or Representatives of any Constituency shall have regard and so far as may be conform to the preponderance of opinion of the members of that Constituency so far as such opinion is known to him or them.

"(5) The Chairman shall in the case of *æ* equality of votes have a casting vote, but shall not otherwise be entitled to vote."

By-law 48.

Existing By-law 46 (to be By-law 48) to be amended (1) by substituting "persons" for "members" in line 2; (2) by inserting "or appointed" after "elected" in line 3; (3) by inserting "members of the Association" after "Twenty-four," and deleting the existing words "of the Association," in sub-para. (a); (4) by inserting "members of the Association" after "Seven," and deleting the existing words "of the Association," in sub-para. (b); (5) by inserting "members of the

Association" after "Twelve," in sub-para. (c); (6) by inserting "members of the Association" after "Four," in sub-para. (d); and (7) by inserting a new sub-para. "(f)" as follows:—

"(f) Persons (if any) appointed by such corporate members and nominating bodies as may be empowered in that behalf by the Representative Body."

[Existing By-law 46.

"COUNCIL. Composition.

"46. The Council shall be composed of the members *ex officio* mentioned in the Regulations and of members elected in manner following, namely:—

"(a) Twenty-four by the Branches and Divisions of the Association in the United Kingdom which shall be grouped for that purpose as hereinafter mentioned.

"(b) Seven by the Branches of the Association not in the United Kingdom which shall be grouped for that purpose as hereinafter mentioned.

"(c) Twelve by the elected Representatives of the Constituencies comprised in the Branches and Divisions of the Association in the United Kingdom, which Branches and Divisions shall be formed for that purpose into twelve groups as hereinafter mentioned, the Representatives of all the Constituencies in each such group being entitled together to elect one member of Council.

"(d) Four by the Representative Meeting, which shall have power to elect such members at such time and in such manner as the Meeting may decide, provided that the term of office of each member so elected shall expire at the close of the Annual Representative Meeting next following the date of his election.

"(e) One medical officer on the active or retired list of each of the following Services, namely:—The Royal Navy Medical Service, the Royal Air Force Medical Service, the Army Medical Service, and the Indian Medical Service, to be elected by the Representative Body from officers nominated by Council, but so that no officer shall be elected who shall have retired from the active list more than five years before the election."

By-law 71.

Existing By-law 69 (to be By-law 71) to be amended, (1) by omitting, in line 4, the words "composed in the manner," and (2) by adding, at the end of the By-law:—

"The said Standing Committees shall be composed in the manner appearing in the said Schedule. Provided that the Council may add to any such Committee a person or persons to represent thereon any corporate member or nominating body which may be authorised by the Representative Body to require such representation."

[Existing By-law 69.

"69. Without prejudice to the foregoing By-laws there shall be Standing Committees, which may include persons who are not members of the Association, called by the names, composed in the manner, and having the powers and duties set forth in the Schedule to these By-laws."

By-law 79.

Existing By-law 77 (to be By-law 79) to be amended by inserting, after "or," in line 4, "in the case of a corporate member or nominated member, addressed to the Secretary of the corporation or nominating body at their last known address, or in the case of any member."

[Existing By-law 77.

"Notices.

77. (1) A notice may be served by the Association upon any member, either personally or by sending it through the post, in a prepaid letter addressed to such member at his last known address, or by publication of such notice in the *Journal*, and sending a copy of the *Journal* containing such notice to such member, prepaid and addressed as above mentioned.

(2) A notice may be served on any Division or Branch by serving the same as aforesaid on the Secretary of such Division or Branch, and if there be none, then on any two members of such Division or Branch.

(3) Any notice, if served by post, shall be deemed to have been served on the day following that on which the letter, or a copy of the *Journal* containing the same, is posted, and in proving such service it shall be sufficient to prove that the letter, or a copy of the *Journal* containing the notice, was properly addressed and put into the Post Office."]

DANGEROUS DRUGS REGULATIONS.

THE following communication has been forwarded to the Medical Secretary of the British Medical Association by Sir Edward Troup, Permanent Under-Secretary of State in the Home Office. Further references to this matter will be found in a Current Note in the SUPPLEMENT, and in Parliamentary Notes in the JOURNAL of this week.

Home Office, Whitehall,
February 25th, 1921.

Sir,

I am directed by the Secretary of State to say that he has had under consideration the letter of February 22nd, signed jointly by yourself and representatives of other bodies, on the subject of the draft Regulations issued under the Dangerous Drugs Act, 1920.

The letter repeats the request made in the previous letter of the Pharmaceutical Society that the Secretary of State will receive a joint deputation from the several bodies signing the joint letter, with a view to the appointment of a committee representative of the different interests to consider the draft Regulations and the objections which have been submitted. After full consideration the Secretary of State is of opinion that the appointment of such a committee is not necessary, would cause much delay, and would not be likely to lead to any useful result.

The interests concerned in the matters dealt with by the regulations are diverse, including the medical and dental professions, pharmaceutical chemists, the managements of hospitals and public institutions, manufacturers of the drugs, wholesale dealers, veterinary practitioners, registered and unregistered, users of the drugs for agricultural purposes, etc., etc.; and while the representatives of any particular interest would be able to speak with regard to his own case, he would not necessarily be able to judge on the application of the Regulations in other cases.

If it be true, as suggested in the joint letter, that the interests of the different bodies are more or less conflicting, the Secretary of State cannot agree that a solution of the difficulties caused by a conflict of interests—for example, as between the pharmaceutical chemist and the medical profession on the question of dispensing—is likely to be found by a joint committee, nor could he allow the Regulations, which are framed for the purpose of carrying out the objects of the International Opium Convention, to be the subject of bargaining between conflicting interests.

It appears to him that the right course is for each of the bodies concerned to confer with the representatives of the Department, who are anxious to remove the misapprehensions which have arisen and to agree to any modifications consistent with the public interest and our international obligations; and if any fear is entertained by some bodies that concessions may be made to other interests which will be injurious to themselves, the Secretary of State will be willing to communicate to the bodies concerned the terms of the modifications he proposes to make in the draft Regulations and to give them an opportunity of submitting further representations.

A letter on similar lines is being sent to the other bodies which signed the joint letter.

I am, Sir, your obedient servant,
(Signed) EDWARD TROUP.

LIBRARY OF THE BRITISH MEDICAL ASSOCIATION.

A LIST of periodical publications, official reports, and Blue Books in the Library of the British Medical Association available for issue to members on loan has been printed, and copies can be obtained free on application to the Librarian at the house of the Association, 429, Strand, W.C. The regulations governing the loan of these publications are stated in the introduction to the list. The Library is open for consultation from 10 a.m. till 6.30 p.m. (on Saturdays 10 a.m. till 2 p.m.).

Association Notices.

MOTIONS FOR ANNUAL REPRESENTATIVE MEETING, NEWCASTLE, JULY, 1921.

NOTICES OF MOTION by Divisions, Constituencies, or Branches, for the consideration of the Annual Representative Meeting of the Association, commencing Friday, July 15th, 1921, proposing to make any addition to, or any amendment, alteration, or repeal of, any Article or By-law, or to make any new Article or By-law, or proposing material alteration of the policy of the Association in matters relating to the honour and interests of the profession or of the Association, must be published in the BRITISH MEDICAL JOURNAL SUPPLEMENT not later than May 14th, and for this purpose should be received by the Medical Secretary **not later than April 30th.**

ELECTION OF REPRESENTATIVE BODY OF ASSOCIATION, 1921-22.

Constituencies in Representative Body.

THE Council has finally grouped the **Home Divisions** for election of the Representative Body 1921-22 in the same manner as for 1920-21, except that the Caithness and Sutherland Division of the Northern Counties of Scotland Branch, and the Rotherham and Sheffield Divisions of the Yorkshire Branch, have been made independent Constituencies.

As intimated to all the **Oversea Bodies**, the Council has made each Oversea Division and Division-Branch an independent Constituency.

Election of Representatives and Deputy-Representatives.

THE REPRESENTATIVES AND DEPUTY-REPRESENTATIVES in the Representative Body *must be elected not later than June 17th*, and their names notified to the Medical Secretary **not later than June 24th.** The Annual Representative Meeting at Newcastle begins on July 15th.

Special attention is drawn to the fact that the election of Representative(s) and Deputy-Representative(s) may, at the discretion of the Constituency, be carried out by General Meeting of the Constituency, or by postal vote.

BRANCH AND DIVISION MEETINGS TO BE HELD.

EDINBURGH BRANCH.—The winter clinical meeting of the Edinburgh Branch will be held in the Royal Infirmary on Friday, March 4th. All members of the profession are cordially invited. The museum will be open from 11 a.m. Arrangements will be made for holding special clinics during the forenoon. The clinical meeting will be held at 3.15 p.m. At 5 p.m. Dr. J. S. Haldane, LL.D., F.R.S., Oxford, will deliver a lecture on "Some recent advances in the physiology of respiration, circulation, and renal excretion." There will be dinner at 6.30 p.m. in the Caledonian Station Hotel; morning dress; dinner ticket, price 10s. 6d.

WORCESTERSHIRE AND HEREFORDSHIRE BRANCH.—The spring meeting of this Branch will be held at Ledbury on Thursday, April 14th, when a British Medical Association Lecture will be given by Mr. P. L. Daniel, F.R.C.S., on "The differential diagnosis of acute abdominal conditions."

Meetings of Branches and Divisions.

LANCASHIRE AND CHESHIRE BRANCH: ROCHDALE DIVISION.
A MEETING of the Rochdale Division was held on February 2nd, when Dr. BATEMAN was in the chair. Dr. Bateman introduced the report of the Consultative Council on Medical and Allied Services, pointing out its chief points which would be to the benefit of the general practitioner, after which the different questions to Divisions were gone into separately and answered. On reaching the portion of the report regarding secondary health centres it was decided to postpone to a future meeting the consideration of the rest of the report.

On the motion of Dr. MILROE, seconded by Dr. BATEMAN, it was resolved to open a divisional list for the Dr. Macdonald testimonial; the sum of nine guineas was collected at the meeting.

METROPOLITAN COUNTIES BRANCH: WILLESDEN DIVISION.

A MEETING of the Willesden Division, to which non-members resident in the area had been invited, was held on February 15th, with Dr. C. T. P. SCOTT in the chair.

The proposals drawn up by Dr. Buchan, Medical Officer of Health, at the request of the Executive Committee of the Division, for the staffing of the clinics of the school treatment and maternity and child welfare centres by part-time medical practitioners were considered, and an interesting discussion took place upon the three schemes prepared, and generally upon the question of the participation of the general

practitioners of the area in any scheme of the local authority for the medical inspection and treatment of school children and maternity and child welfare work, in the course of which the Deputy Medical Secretary of the Association gave details of a scheme in operation in Scotland, in the working of which there was complete co-operation between the authority and the local profession.

None of the schemes prepared by Dr. Buchan (for the utilization of the services of part-time practitioners) being considered satisfactory, it was agreed to consult the whole of the local profession individually upon the question. Instructions were given to a subcommittee, consisting of Drs. MacEvoy, Skene, Scott, Grainger Evans, with the Secretary, Dr. Paterson, to prepare a draft scheme for submission to a subsequent meeting of the Division. It was felt that prior to the preparation of the draft scheme it would be necessary to ascertain from each practitioner in the area whether he was prepared (1) to take part in the medical inspection of school children; (2) to participate in the treatment, and if so of what diseases, of the children who must be treated under the authority's scheme, and to participate in the work at the local authority's maternity and child welfare clinic. It was pointed out that in all cases the private practitioner would be adequately remunerated for any work, and that the schemes must be approved by the Council of the Association.

During the discussion the speakers all referred to the necessity for the utmost harmony in the relationship between the medical officials of the local authority and the local profession, and a letter was read from a former Secretary of the Division to one of the members present. This letter expressed the pleasure of the writer at seeing that the Willesden Division was still taking such a keen interest in medical politics, stating that he was a seceder from the ranks of general practitioners and had become a Government official, and from that point of view it was more than ever impressed upon him how much the officials were dependent upon the goodwill of the general practitioner; that much of the prejudice of the general practitioner against the official was undoubtedly due to a very great extent to the fact that the two sides did not come into personal contact, and that he was glad to see that the members of his old Division were going the right way to work in meeting the officials and securing an interchange of views, and were apparently anxious, not only for a share in the work, but for new opportunities that were likely to arise for increasing their experience and medical knowledge.

The conference on the Interim Report on the Future Provision of Medical and Allied Services, convened by the Chairman of the Willesden Urban District Council, was continued in the Council Chamber, Kilburn, on Thursday, February 17th. It was agreed to adopt the proposals set out in the Report of the Consultative Council on Medical and Allied Services, to the conditions obtaining in Willesden, and the question of how far the existing accommodation at the various institutions and hospitals in the parish could best be used was gone into, having regard to present statutory restrictions and regulations, in order that the present accommodation available could be fully used by the sick of Willesden.

A scheme was outlined whereby, in the event of further legislation, a systematized provision of all forms of medical and allied services in the parish could be made available for the inhabitants of Willesden, based on the lines of the report of the Consultative Council.

The pooling of the existing hospital accommodation and the allocation to them of work was considered—for instance, the Municipal Hospital was suggested for all infectious cases, the Willesden Infirmary for maternity cases, diseases of women, and other diseases of adults, the Willesden Hospital for diseases of children and adults, and St. Monica's Home, Brondesbury, for the same.

It was agreed:

- That the Willesden Infirmary or the Willesden Hospital should become the general hospital for Willesden, and should include provision for general and special services, laboratories, and other services, as set out in the "Dawson Report."
- That everything should be done to ensure the hearty co-operation of the general medical practitioner in the parish.
- That, as far as may be practicable, all public medical work in institutions or otherwise, should be carried out by part-time general medical practitioners.
- That primary health centres on the lines of the "Dawson Report" should be established.
- That, should it not be practicable to have beds attached to primary health centres, wards should be set apart at the various hospitals in Willesden where patients may be attended by their own medical practitioners.
- That a Local Medical Advisory Council should be formed on the lines of the "Dawson Report."

NORTH OF ENGLAND BRANCH: NORTH NORTHUMBERLAND DIVISION.

THE annual report shows that during 1920 six meetings of the Division were held, four being at Alnwick, one at Belford, and one—the annual summer meeting—at Bamburgh. It was decided at the second meeting in February that in future meetings the chief aim should be scientific. In pursuance of this course Dr. Hume was invited and attended the meeting at Belford in April, when he gave a most instructive and comprehensive address on "Disorders of the heart in pensioners"; whilst Dr. Bolam, with the help of Dr. Thompson, was present at the Infirmary at Alnwick in October to give an address and practical demonstration on the diagnosis and treatment of syphilis by modern methods. These two meetings were well

attended and thoroughly appreciated; the best thanks of the Division were accorded to the lecturers and demonstrator. The report notes with satisfaction that, with one exception, every medical man in active practice within the area of the Division is a member of the British Medical Association. On December 1st a very successful and well attended dinner was held at Alnwick for the purpose of meeting and hearing an address from Dr. Cox, the Medical Secretary.

NORTH OF ENGLAND BRANCH: STOCKTON DIVISION.

AT the last meeting of the Stockton Division the contemplated issue by the Home Office of an order under the Dangerous Drugs Act was discussed and the following resolution was unanimously adopted:

The Stockton Division of the British Medical Association considers that the order in question will serve no public interest and will impose unnecessary clerical work on medical practitioners.

A copy of the resolution has been sent to the Home Secretary, and the local member of Parliament has been personally interviewed in regard to the matter.

Contract rates for medical attendance on members of police force were also discussed. It was agreed that a fee of 26s. per head per annum for urban districts was reasonable, and that mileage should be extra in rural areas. The North of England Branch was asked to secure united action in the matter.

NORTH LANCASHIRE AND SOUTH WESTMORLAND BRANCH: LANCASTER DIVISION.

THE following resolution was passed at a meeting of the profession held at the County Hotel, Lancaster, on February 20th:

Having carefully considered the draft Regulations under the Dangerous Drugs Act, as applied to medical men, we consider the conditions impossible to carry out.

SOUTHERN BRANCH: PORTSMOUTH DIVISION.

AT a recent meeting of the Portsmouth Division the proposed draft Regulations for the sale of morphine, heroin, and opium (medicinal) were discussed, and the following resolutions were adopted and forwarded to the Home Secretary:

- That this meeting of Portsmouth medical men protests against the action of the Home Secretary in formulating Regulations for the sale of dangerous drugs, etc., without consulting the largest organized body of medical men in the kingdom—the British Medical Association.
- That the medical men of the Portsmouth District, emphatically protest against the proposed Regulations under the Dangerous Drugs Act; that these regulations, if carried out, would have a most detrimental psychic effect on our patients; that they are unnecessary; and that the new clerical work and its concurrent inquisition are degrading and impossible of fulfilment for the medical profession—one of the hardest worked professions in the kingdom; and we further regard these draft Regulations as an intolerable and unwarrantable interference with our rights and privileges, and a slur on our honour and bona fides.

Mr. Atterbury was present at the meeting as representative of the local Pharmaceutical Society, and gave invaluable help and information.

SOUTH WALES AND MONMOUTHSHIRE BRANCH: NORTH GLAMORGAN DIVISION.

A MEETING of the North Glamorgan and Brecknock Division was held at Aberdare on February 17th, when Dr. F. J. JAYNE was in the chair. This was the first Division meeting to be held at the Aberdare Hospital, and every one testified that it had been thoroughly enjoyable. The SECRETARY gave extracts from the Medical Secretary's monthly report, observing that these reports of the Medical Secretary were very interesting and useful. The draft Regulations regarding dangerous drugs, a copy of which had been sent to most members present, was then considered, and the following resolution was carried:

That we, as medical men, having perused the draft circular of Regulations re dangerous drugs, are of opinion that the suggested regulations are utterly impracticable, and are futile to meet the real intention of same, whilst at the same time penalizing medical men, and imposing on them that which cannot be carried out. We therefore appeal to the authorities not to put them into operation in their present form, and without consulting the profession as to the best means of arriving at practical regulations, which will meet with the requirements and prevent illicit sale by unauthorized persons.

The resolution was directed to be forwarded to the Home Secretary, and in addition every one present promised to write a personal letter to the Home Office and to their respective Members of Parliament. At the invitation of the Division, Dr. T. R. LLEWELLYN, Regional Medical Officer to the Ministry of Health for the area, was present, and addressed the Division regarding his work and the relationship between himself and medical men and the Ministry of Health, emphasizing more particularly the new records which panel practitioners are asked to keep. Dr. Llewellyn pointed out that the profession were in honour and duty bound under an obligation to give the records a trial, and he explained what was really expected, and indicated that the records were of clinical and administrative importance. Several members asked questions and criticized the records from various points of view, and an interesting and useful discussion ensued. At the close, Dr. Llewellyn acknowledged his indebtedness to the Division for the opportunity of addressing them on this important if thorny subject of records, and a vote of thanks was accorded him for his presence and address.

British Medical Association.

EIGHTY-NINTH ANNUAL MEETING, NEWCASTLE-UPON-TYNE, JULY, 1921.

Patron: HIS MAJESTY THE KING.

President: The Right Hon. Sir T. CLIFFORD ALBUTT, P.C., K.C.B., F.R.S., Regius Professor of Physic, University of Cambridge.

President-Elect: DAVID DRUMMOND, C.B.E., M.A., M.D., D.C.L., Pro-Vice-Chancellor and Professor Principles and Practice of Medicine, University of Durham.

Chairman of Representative Meetings: T. W. H. GARSTANG, M.A., M.R.C.S., D.P.H.

Chairman of Council: R. A. BOLAM, O.B.E., M.D., M.R.C.P.

Treasurer: G. E. HASLIP, M.D.

PROGRAMME.

The President will give an Address on Tuesday, July 19th, at 8 p.m.

The REPRESENTATIVE MEETING will begin on Friday, July 15th, at 10 a.m., and be continued on the following days.

The statutory ANNUAL GENERAL MEETING will be held on July 19th, at 2 p.m., and the Adjourned General Meeting at 8 p.m.

The Annual Dinner of the Association will take place on Thursday, July 21st, at 7.30 p.m.

Religious services will be held on Tuesday, July 19th, at 5 p.m.

The Conference of Secretaries will be held at 2 p.m. on Wednesday, July 20th, and the Secretaries' Dinner will take place in the evening at 6.30.

A Special Address on Industrial Medicine will be given by Sir Thomas Oliver, M.D., on Wednesday, July 20th, at 8 p.m.

The Popular Lecture will be delivered by Professor Arthur Keith, F.R.S., on Friday, July 22nd, at 7.30 p.m.

DEMONSTRATIONS.

Laboratory and Clinical Demonstrations will be given on Wednesday, July 20th, Thursday, July 21st, and Friday, July 22nd, between 3 p.m. and 4.30 p.m.

THE SECTIONS.

The Sections will meet from 10 a.m. to 1 p.m.

The following Sections meet on three days Wednesday, Thursday, and Friday, July 20, 21, and 22.

MEDICINE.

President: Professor THOMAS BEATTIE, M.D., F.R.C.P.
Vice-Presidents: The Right Hon. LORD DAWSON OF PENN, G.C.V.O., M.D., F.R.C.P.; Professor A. J. HALL, M.D., F.R.C.P.; G. S. HAYNES, M.D.; J. WILKIE SMITH, M.D.
Honorary Secretaries: Professor W. E. HUME, C.M.G., M.D., F.R.C.P., (4, Ellison Place, Newcastle-on-Tyne); C. E. LAKIN, M.D., F.R.C.P., (105, Harley Street, London, W.1); W. T. RITCHIE, O.B.E., M.D., F.R.C.P.Ed. (14, Rothesay Place, Edinburgh).

SURGERY.

President: Professor J. RUTHERFORD MORISON, F.R.C.S.
Vice-Presidents: Professor H. BRUNTON ANGUS, F.R.C.S.; ARTHUR COOKE, F.R.C.S.; W. J. GREER, F.R.C.S.I.; A. M. MARTIN, M.B.
Honorary Secretaries: W. GIRLING BALL, F.R.C.S. (77, Wimpole Street, London, W.1); J. M. RENTON, F.R.C.S. (16, Sandyford Place, Glasgow, W.); G. GREY TURNER, M.S., F.R.C.S. (The Hawthorns, Osborne Road, Newcastle-on-Tyne).

PATHOLOGY AND BACTERIOLOGY.

President: Professor STUART McDONALD, M.D., F.R.C.P.Ed.
Vice-Presidents: J. F. GASKELL, M.D., F.R.C.P.; JAMES A. MURRAY, M.D.; Professor MATTHEW J. STEWART, M.B.
Honorary Secretaries: R. R. ELWORTHY, O.B.E., M.D. (West London Hospital, Hammersmith, London, W.6); A. F. BERNARD SHAW, M.D. (Pathological Department, College of Medicine, Newcastle-on-Tyne).

PREVENTIVE MEDICINE WITH INDUSTRIAL DISEASES.

President: Sir THOMAS OLIVER, M.D., F.R.C.P., LL.D.
Vice-Presidents: Sir JOSIAH COURT, M.R.C.S.; T. EUSTACE HILL, O.B.E., M.B.; I. G. MODLIN, O.B.E., M.D.
Honorary Secretaries: W. H. DICKINSON, O.B.E., M.B. (1, Ridley Villas, Newcastle-on-Tyne); C. M. WILSON, M.C., M.D. (64, South Audley Street, Grosvenor Square, W.1).

ORTHOPAEDICS AND DISEASES IN CHILDREN.

President: A. H. TUBBY, C.B., C.M.G., M.S., F.R.C.S.
Vice-Presidents: R. C. ELSMLIE, O.B.E., M.S., F.R.C.S.; H. MORLEY FLETCHER, M.D., F.R.C.P.; LACHLAN G. FRASER, M.D.; Sir HENRY M. W. GRAY, K.B.E., C.B., C.M.G., F.R.C.S.; A. E. MORISON, F.R.C.S. (Director of Demonstrations).
Honorary Secretaries: FRANK HAWTHORN, D.S.O., M.D. (10, Ellison Place, Newcastle-on-Tyne); C. MAX PAGE, D.S.O., F.R.C.S. (134, Harley Street, London, W.1); H. R. SOUPER, M.D. (Ministry of Pensions Hospital, Castle Leazes, Newcastle-on-Tyne).

The following Sections meet on two days.

NEUROLOGY AND PSYCHIATRY.

President: Professor A. W. MACKINTOSH, M.D., F.R.C.P.Ed.
Vice-Presidents: A. HELEN A. BOYLE, M.D.; E. FARQUHAR BUZZARD, M.D., F.R.C.P.; HARRY CAMPBELL, M.D., F.R.C.P.; HORSLEY DRUMMOND, M.D.
Honorary Secretaries: ANTHONY FEILING, M.D. (41, Devonshire Street, London, W.); GEORGE HALL, M.D., C.M.G. (1, Elington Road, Jesmond Road, Newcastle-on-Tyne).

OBSTETRICS AND GYNAECOLOGY.

President: Professor R. P. RANKEN LYLE, M.D.
Vice-Presidents: Lady BARRETT, M.D.; W. R. GROVE, M.D.; WILLIAM ROBINSON, F.R.C.S.
Honorary Secretaries: MABEL R. CAMPBELL, M.B. (49, Wimpole Road, Newcastle-on-Tyne); GORDON LEY, F.R.C.S. (5, Wimpole Street, London, W.1); E. FARQUHAR MURRAY, M.D., F.R.C.S. (52, Jesmond Road, Newcastle-on-Tyne).

OPHTHALMOLOGY.

President: Professor J. D. WARDALE, M.B., B.S.
Vice-Presidents: H. P. BENNETT, M.B.; Lieut.-Colonel R. H. ELLIOT, M.D., F.R.C.S., I.M.S. (ret.); HARRY M. TRAUQUAIR, M.D., F.R.C.S.Ed.
Honorary Secretaries: N. B. B. FLEMING, M.B., Ch.B. (9, Harley Street, London, W.1); STANLEY ROBSON, M.S., F.R.C.S.Ed. (Milton House, Rowlands Gill, co. Durham).

OTO-RHINO-LARYNGOLOGY.

Not yet completed.

PHYSIOLOGY, PHARMACOLOGY, THERAPEUTICS, AND DIETETICS.

President: H. H. DALE, C.B.E., M.D., F.R.S.
Vice-Presidents: Professor A. V. HILL, M.A., D.Sc., F.R.S.; Professor JOHN C. MEAKINS, M.D.; Professor J. A. MENZIES, M.D.; ALFRED PARKIN, F.R.C.S.
Honorary Secretaries: Miss MILDRED ATKINSON, B.Sc. (College of Medicine, Newcastle-on-Tyne); O. INCHLEY, M.D. (Babraham, Cambridge).

VENEREAL DISEASES.

President: Colonel L. W. HARRISON, D.S.O., R.A.M.C.
Vice-Presidents: JAMES CHARLES BUCKLEY, M.D.; CHARLES GIBBS, F.R.C.S.; MARY RAW, M.B.
Honorary Secretaries: KENNETH M. WALKER, O.B.E., F.R.C.S. (86, Harley Street, London, W.1); JAMES HUDSON, M.D. (42, Crossley Terrace, Newcastle-on-Tyne).

The following Sections meet on one day.

AMBULANCE AND RED CROSS.

President: Sir JAMES CANTLIE, K.B.E., F.R.C.S.
Vice-Presidents: ROBERT ANDERSON, M.D.; Sir G. T. BEATSON, K.C.B., K.B.E., M.D.; Major-General Sir G. J. H. EVATT, K.C.B., M.D.; Rev. C. F. TOWNLEY, M.A.

Honorary Secretaries: Lieut.-Colonel R. M. VICK, O.B.E. (The Warden's House, St. Bartholomew's Hospital, E.C.1); H. L. RUTTER, M.B.E., F.R.C.S., (31, West Parade, Newcastle-on-Tyne).

DERMATOLOGY.

President: JOHN FARQUHAR CHRISTIE, M.B.
Vice-Presidents: ERNEST DORE, M.D., F.R.C.P.; ARTHUR D. HEATH, M.D., M.R.C.P.; D. WELLS PATTERSON, O.B.E., M.B., M.R.C.P.

Honorary Secretaries: WILLIAM JENKINS OLIVER, M.B. (53, Queen Anne Street, London, W.1); SYDNEY THOMPSON, M.B., B.S. (19, Windsor Terrace, Newcastle-on-Tyne).

MEDICAL SOCIOLOGY.

President: Sir JENNER VERRALL, LL.D., M.R.C.S.
Vice-Presidents: CHARLES BUTTAR, M.D.; A. C. FARQUHARSON, M.D., M.P.; E. ROWLAND FOTHERGILL, M.B., B.S.

Honorary Secretaries: MABEL G. BRODIE, M.B. (Maternity and Child Welfare Offices, 42, Old Elvet, Durham); J. F. WALKER, M.B. (Rocklands, Clifton Terrace, Southend-on-Sea).

PROCTOLOGY.

President: J. P. LOCKHART-MUMMERY, F.R.C.S.
Vice-Presidents: HENRY B. DENSHAM, M.B.; W. ERNEST MILES, F.R.C.S.; D. P. D. WILKIE, O.B.E., F.R.C.S.

Honorary Secretaries: CECIL W. ROWNTREE, F.R.C.S. (9, Upper Brook Street, London, W.1); HAMILTON DRUMMOND, F.R.C.S. (6, Saville Place, Newcastle-on-Tyne).

RADIOLOGY AND ELECTRO-THERAPEUTICS

Not yet completed.

UROLOGY.

President: J. W. THOMSON WALKER, O.B.E., F.R.C.S.
Vice-Presidents: P. J. CAMMIDGE, M.D.; JOHN CLAY, C.B.E., F.R.C.S.; H. C. PEARSON, F.R.C.S. Ed.

Honorary Secretaries: SYDNEY G. MACDONALD, F.R.C.S. (51, Queen Anne Street, London, W.1); W. S. DICKIE, O.B.E., F.R.C.S. (Ardencape, Southfield Road, Middlesbrough).

The Honorary Local General Secretary of the meeting is R. J. Willan, O.B.E., M.V.O., F.R.C.S., 6, Keusington Terrace, Newcastle-on-Tyne.

INSURANCE.

CORRESPONDENCE.

The New System of Medical Records.

SIR,—The letter of Dr. T. Wood Locket in your issue of February 19th is worthy of the fullest consideration by all panel practitioners and Committees. He has been good enough to refer in his detailed scheme to the suggestion contained in the second part of the amendment placed on the agenda of the last Panel Conference by the Warrington Panel Committee. This Committee felt that the proper time to suggest amendments to the scheme of the Inter-departmental Committee on Medical Records was before the expense had been incurred in the manufacture and issue of the cards, but apparently those who swayed the last Panel Conference were also members of that Inter-departmental Committee, and the mover of the amendment—Dr. Ferguson—did not find a seconder. When passing this amendment the Warrington Committee had in memory the practical failure of the two previous methods of keeping records—the “floppy” book of 1913 and the stacks of parcelled cards which, dust-ridden, still encumber insurance offices, and it desired to limit the present experiment in the interests of economy and efficiency.

The mistake of the Interdepartmental Committee was its recommendation to issue cards to all insurance practitioners for all insurance patients, not recognizing that a very large proportion of these practitioners either by training, temperament, or by the arduous nature of their work are not fitted to keep such accurate records as to be reliable for statistical or other purposes. The argument that the scrappy notes on the back of an envelope are likely to benefit medical research is surely the height of fatuity, and even if some observation of purest ray serene were made by a genius for research, what chance would it have of being discovered “in its dark unfathomable cave” by the docketing clerks and the officers of the Ministry? Clinical records have some value, which, however, should not be exaggerated; the real question is whether they are worth the time, labour, and expense that are involved in keeping them.

There is another aspect on which I think all will agree—namely, that the Government is entitled to know what attendances are being given to the insured population. This information should be as accurate and reliable as possible, and Dr. T. Wood Locket's scheme of selecting a certain proportion of practitioners in each area working amongst a fair sample of the population seems to me to be the most likely to give accurate results. Panel practitioners would, of course, have to agree to accept inferences from these figures, and they would have to meet the expense, as Dr. Locket suggests, from the medical pool.

If some such limited scheme as this had been adopted from the first, there would have been none of the present outcry against records, and the panel-prying stunt of the *Daily Mail* would not even have had its present insubstantial basis.

Now that the cards have been issued, let us use them, as Dr. Locket suggests, for clinical notes in cases that suggest themselves to our clinical conscience, and leave the other details of attendances, certificates, etc., to medical recorders.—I am, etc.,

J. S. MANSON,

Warrington, Feb. 20th. Hon. Sec., Warrington Panel Committee

SIR,—The panel record card system puts the profession in the ambiguous position of the mythical preacher who taught us to act according to his preaching but not according to his deeds.

The profession has taught the lessons of industrial fatigue in relation to poor work, to accidents, and to disease and the longevity of the operatives. It has investigated this matter very carefully, and has arrived at some perfectly true, because scientific, conclusions. And having arrived at those conclusions, it has proceeded to violate its own idol by imposing on its members, already overworked, an additional and unnecessary imposition. To secure the problematical ideal of a clinical record of insured persons a nobler ideal—a demonstrated and dictated ideal—has been shattered. An imposition has been laid upon the shoulders of the overworked; by so doing we are degrading ourselves and eating our own words and impairing our efficiency.

Then how fatuous is the purpose of the records! Records for statistical scientific purposes we could understand even if we disapproved of the burden of keeping them. Records for disciplinary purposes we could understand. But records for clinical purposes! Have men become so altruistic that they have forgotten self to such an extent that all their past illnesses are forgotten? Or is there an epidemic of amnesia?—I am, etc.,

Pensilva, near Liskeard, Cornwall.

J. C. JONES, M.B.

SIR,—There is one aspect of the present system of records which is extremely irritating to a busy medical man, and which is quite unnecessary.

A patient walks in and says he is an insured patient, but has not got his medical card with him. The following process has then to be carried out:

1. A diagnosis has to be made and a prescription written. I am not sure whether this prescription ought to be on the usual insurance forms in triplicate or on private prescription forms.
2. Next a certificate has to be given that the patient is unfit for work.
3. Then an account for temporary residents has to be filled up and signed by the patient and endorsed by the doctor to the effect that the patient cannot produce his medical card and has paid a fee.
4. Next a continuation card has to be filled in with any necessary clinical details.
5. And an official receipt has to be given for the fee paid. It frequently happens that the patient then goes home, and the doctor sees him no more.
6. It is now the duty of the doctor—who supposes, from the non-appearance of the patient for, say a week, that the case is concluded—to send up the form of account and the continuation card to the clerk to the Insurance Committee.

Is not this an absurd amount of red tape? Its only object so far as I can see is to pander to careless patients. Would it not be much better and simpler to make patients who cannot produce their medical cards pay fees like private patients? This is a particular hardship in health resorts where there is a great influx of visitors.—I am, etc.,

Sandown, I.W., Feb. 28th.

H. B. BILLUPS,

INSURANCE COMMITTEES.

LONDON.

Scale of Fees under “Own Arrangements.”—The London Insurance Committee, at its meeting on February 24th, approved a revised scale of fees for the calculation of the sums expended by insured persons who are allowed to make their own arrangements. The scale hitherto in operation was adopted in 1913, and objections have been raised to its continuance in view of

the altered conditions now prevailing. The new scale is as follows:

	s.	d.
Attendance on patient at practitioner's residence, surgery, or dispensary	3	0
Visit to patient's residence	4	6
Special visit, such as visit made by patient's desire on same day as that on which a call is received after 10 a.m. or on Sunday	4	6
Night visit (between 8 p.m. and 8 a.m., in response to call received between those hours)	6	0
Surgical operation requiring local or general anaesthetic, or case of abortion or miscarriage	21	0
Administration of general anaesthetic	21	0
Setting of fracture (femur 2ls.) others	10	6
Reduction of dislocation (hip 2ls.), others	10	6
Fee for report	2	6
Fee for attendance for giving certificates	1	0

Subsequent attendances after the setting of a fracture or reduction of a dislocation are to be at "visit" rate.

Correction of Practitioners' Lists.—It was reported that corrected lists, representing nearly 200,000 persons, had been supplied to 237 practitioners in the London area, leaving over 1,200 practitioners' lists to be corrected in accordance with the requirements of the Distribution Fund. The correction, so far as it has gone, has shown that the number of medical index cards, which record the number of insured persons on each practitioner's list, differs to the extent of 9 or 10 per cent. from the figures of credit in the book ledgers: in the case of some practitioners the figures of credit are less than the number of cards, and in other cases more. It is upon the basis of these figures of credit that, for administrative convenience, the practitioners concerned have been paid, as it is impracticable to count on each quarter day the actual number of cards on the lists of 1,500 doctors, and these figures are adjusted by additions and corrections as they occur. Cases are given in which the figures of credit as a result of the correction have been reduced by several hundreds. In one case, when the figures before correction were 2,416, they have been reduced by 609, involving a monetary adjustment per annum of £334 19s. It is understood that the effect of correcting practitioners' lists now in progress will not vary the total amount available for distribution, but it will alter the incidence of payment of individual practitioners. Steps are being taken to ensure the maintenance of a correct list, both of figures of credit and medical index cards, and to secure that the adjustments in the two methods of record are carried out uniformly.

LOCAL MEDICAL AND PANEL COMMITTEES.

LONDON.
Record Cards.—At the meeting of the London Panel Committee on February 22nd, the question of record cards was again discussed, and the Committee accepted two recommendations of a subcommittee to the effect that some form of medical record was necessary, and that practitioners should not be required to enter matters on the record cards which in their opinion were likely to be detrimental to the interests of the insured persons concerned. A third recommendation, however, that the Committee should express no opinion with regard to the present form of record until it had been in use for a period of six months, was opposed by Dr. E. A. Gregg and others. Dr. Gregg agreed that a clinical record might be of great value, but he objected to the time-sheet, and pointed out various drawbacks, such as, for instance, that the period during which the practitioner was most busily engaged in attending to the patient was likely to be the very period during which he would omit to make the entries, and consequently would receive no credit for the work he was doing. The recommendation of the subcommittee was lost, and Dr. Gregg then moved:

"That in the opinion of the London Panel Committee the present medical records are neither advantageous to the medical service nor beneficial to the community, and that it is desirable that they be discontinued forthwith."

In spite of a remonstrance from the chairman of the Committee (Dr. Cardale), who said that the passing of this motion would be a futile proceeding and one not quite worthy of the reputation of the London Panel Committee, which had always stood for sanity in insurance policy, the motion was carried by about 22 to 12.

Services of a Second Practitioner.—A recommendation was before the Committee that an account for the services of a second practitioner in administering a general anaesthetic in a certain case be disallowed on the ground that a general anaesthetic was not necessary; the operation was for the evacuation of an abscess in quinsy. The practitioner attended before the Committee and said that in this case the patient, who was a young girl, could not or would not open her mouth without a general anaesthetic, and he produced other medical opinion to show that such an anaesthetic was necessary. After hearing the practitioner, who added to his evidence a protest against the waste of time involved in such an inquiry, the Committee unanimously rejected the subcommittee's recommendation and allowed the charge. In another case an account for emergency treatment was disallowed on the ground that although the patient's own doctor had been sent for, and was not available, his deputy had not been sent for and another practitioner was called in.

Dangerous Drugs Regulations.—The Committee agreed to make a protest against the draft regulations, issued by the Home Office, under the Dangerous Drugs Act, with regard to the prescribing and dispensing of certain drugs. An inquiry is to

be made of the Ministry of Health as to the obligations laid upon insurance practitioners, and the Ministry is to be asked to use its influence to obtain a postponement of the Regulations.

BRIGHTON.

The following resolutions have been unanimously adopted:

Medical Records.

That this meeting of insurance practitioners for Brighton, having considered the present record cards, is of opinion that they should be given a fair trial, but that in order to safeguard so far as possible the secrecy of the information given thereon, the Ministry of Health should claim privilege as being confidential documents, the contents of which ought not in the public interest to be disclosed; and, further, should take from time to time any other steps which would tend to secure most fully that secrecy which is essential for successful medical practice and is required for reliable statistical data.

Dangerous Drugs Regulations.

Having considered the Regulations proposed to be issued by the Home Office under the Dangerous Drugs Act, the Panel and Local Medical Committee for Brighton is of opinion that: (a) The procedure which it is required that the insurance practitioners should adopt will prove, under the unnecessary official interference with everyday practice, both irksome and detrimental to the interests of the insured person, seeing that the consequence will be in many cases to deprive such persons of the drugs which would otherwise be given, or, if they are given, their required advertisement on the bottle will have a harmful effect on the patient in many cases. (b) The insurance practitioner should be allowed, as heretofore, every latitude in determining the drugs considered most desirable for his insurance patient, without having to disclose to any inspecting officials professional matters, and should be responsible to the Minister of Health alone for his actions.

GLOUCESTERSHIRE.

At a joint meeting of the Gloucestershire Local Medical and Panel Committee and the corresponding Committee of the County Borough of Gloucester, held on February 1st, the following resolution was adopted:

That, in the opinion of this meeting, the record cards should take the place of the medical cards, and should be in the possession of the insured persons, who should be responsible for them and should produce them when required by the practitioners, and should surrender them for inspection from time to time in the same way as they surrender the stamped cards. Further, that the practitioners should only be responsible for such entries on the records as would afford a useful and continuous clinical record; all other particulars—for example, age, employment, etc.—being supplied by the approved societies.

A copy of the resolution has been forwarded to the Ministry of Health.

Naval and Military Appointments.

ROYAL NAVAL MEDICAL SERVICE.

The following appointments are announced by the Admiralty: Surgeon Commanders F. H. Stephens, O.B.E., to the *Cambrian*, G. C. Cross to the *Cleopatra*, J. L. Barford to the *Pembroke*, for R.N. Barracks, Chatham (temporary), F. E. Bolton to the *Southampton*, Surgeon Lieutenant Commanders A. C. Paterson to the *Caroline*, A. S. Paterson to the *Crescent* (temporary), G. L. Ritchie, M.C., to the *Southampton*. Surgeon Lieutenant J. F. M. Campbell to the *Factory*, Surgeon Lieutenant (temporary) T. L. P. Harries to the *Indus*. To be Surgeon Lieutenant: J. W. Tighe.

ARMY MEDICAL SERVICE.

ROYAL ARMY MEDICAL CORPS.

Major H. M. J. Perry, O.B.E., to be a Professor at the Royal Army Medical College.

Major T. H. Gibbon, O.B.E., retains the temporary rank of Lieutenant-Colonel whilst specially employed.

Major P. J. Marett retires, receiving a gratuity, and is granted the rank of Lieutenant-Colonel.

Temporary Captain S. A. McClintock to be temporary Major whilst specially employed.

The notification in the *London Gazette* of July 1st, 1919, regarding Captain O. D. Jarvis is cancelled.

To be temporary Captains: C. B. Dyson, late Captain S.R. (seniority from November 7th, 1919), R. T. G. Aickin, late temporary Captain (seniority from February 3rd, 1917).

Temporary Captain F. W. H. Pilot relinquishes his commission.

INDIAN MEDICAL SERVICE.

Major Geoffrey Gratix Hirst to be an officer in charge, Medical Store Depot, vice Lieut.-Colonel William Davey Hayward, M.B., retired, August 5th, 1920.

The promotion to present rank of Major Robert Knowles is antedated from February 1st, 1920, to August 1st, 1919.

Lieut.-Colonel D. W. Sutherland, C.I.E., V.H.S., M.D., Principal and Professor of Medicine, King Edward Medical College, Lahore, is granted, with effect from January 15th, 1921, furlough on average salary for five months and in continuation vacation leave for three months.

Lieut.-Colonel E. V. Hugo, C.M.G., M.D., F.R.C.S., V.H.S., Professor of Surgery, King Edward Medical College, Lahore, is appointed to officiate as Principal of the College during the absence on leave of Lieut.-Colonel D. W. Sutherland until further orders.

Major J. J. Harper Nelson, O.B.E., M.C., M.D., F.R.C.S.E., Professor of Materia Medica, King Edward Medical College, Lahore, is appointed to officiate as Professor of Medicine in the College, with effect from date on which he assumes charge of his duties and until further orders.

Captain Amir Chand, M.B., is appointed to officiate as Professor of Materia Medica in the College, with effect from date on which he assumes charge of his duties and until further orders.

The services of Captain H. R. H. Robson, M.B., are placed temporarily at the disposal of the Government of Burma (December 13th, 1920).

Lieut.-Colonel F. H. G. Hutchinson, M.B., D.P.H., D.T.M., Sanitary Commissioner with the Government of India, is granted privilege

leave for six months and in continuation furlough on average salary for four months and ordinary furlough for two months, with effect from February 14th, 1921, or such subsequent date on which he may avail himself of the leave.

Lieut.-Colonel A. B. Fry, C.I.E., D.S.O., M.D., D.P.H., Special Deputy Sanitary Commissioner, Bengal, is placed on special duty under the Director-General Indian Medical Service, with effect from February 1st, 1921. He is appointed to officiate as Sanitary Commissioner with the Government of India, with effect from February 14th, 1921, or such subsequent date on which Lieut.-Colonel F. H. G. Hutchinson, M.B., D.P.H., D.T.M., proceeds on leave. Lodging allowance has been fixed at 12s. a day, irrespective of rank, for officers on study leave.

TERRITORIAL FORCE.

ROYAL ARMY MEDICAL CORPS.

Lieut.-Colonel P. R. Ash resigns his commission and retains the rank of Lieutenant-Colonel. Lieut.-Colonel J. B. Berry, T.D., relinquishes his commission on account of ill health, and retains the rank of Lieutenant-Colonel.

Captain D. G. Rice Oxley, M.C., to be Lieutenant-Colonel and command the 1st London (City of London) Field Ambulance.

Major N. Maclaren, T.D., to be Lieutenant-Colonel and command 1st Western Casualty Clearing Station.

To be Majors: Captain G. B. Gill, May 27th, 1920 (substituted for notification in the *London Gazette*, December 31st, 1920), W. Bowater, Surgeon-Major R. L. FitzGerald, from 5th Battalion East Lancashire Regiment, with precedence as from January 16th, 1916. Captain C. H. S. Redmond, Captain W. D. Carruthers, from 1st London (City of London) Sanitary Company, with precedence as from December 1st, 1915.

Captain (acting Lieut.-Colonel) J. R. Pooler, O.B.E., relinquishes his acting rank on ceasing to be employed.

Captain L. E. G. de Glanville (late R.A.M.C.) to be Lieutenant with precedence as from February 27th, 1915, and to relinquish the rank of Captain, July 21st, 1920 (substituted for notification published in the *London Gazette*, January 3rd, 1921, under the name L. R. G. de Glanville).

Captain (acting Major) W. C. Gunn relinquishes his acting rank on ceasing to be specially employed.

To be Captains:—Majors and to relinquish the rank of Major, J. L. Menzies, M.C. (late R.A.M.C.), with precedence as from May 10th 1918; P. J. Gaffikin, M.C. (late R.A.M.C.S.R.), with precedence as from April 1st, 1915; Captain H. W. Featherstone (late R.A.M.C.S.R.), with precedence from June 1st, 1913; Captain T. Carnwath, D.S.O., from T.F.Res. (August 3rd, 1920); Captain A. C. MacDonald, M.C. (late R.A.M.C.S.R.), with precedence as from February 10th, 1917; Captain H. L. Garson, O.B.E., M.C. (late R.A.M.C.S.R.), with precedence from May 13th, 1915.

Captain D. Buchanan is seconded under para. 114, T.F. Regulations. The following officers resign their commissions: Lieut.-Colonel C. S. Brebner, D.S.O., and retains the rank of Lieutenant Colonel. Major W. Macdonald, and retains the rank of Major. Captains J. Dale, O.B.E., and A. C. Mallace, M.C., and are granted the rank of Major. Captains and retain the rank of Captain: H. C. Gilmore, W. H. Dater, J. Morley, J. H. Barclay, L. T. Whelan, M.C.

To be Lieutenants: Captain T. D. Webster (late R.A.M.C.), with precedence as from May 7th, 1917, and to relinquish the rank of Captain. Lieutenant R. K. Nisbet (late R.A.M.C.), with precedence as from January 10th, 1915; Second Lieutenant R. J. Dyson, from T.F.Res. (West Yorkshire Regiment).

TERRITORIAL FORCE RESERVE.

ARMY MEDICAL SERVICE.

Major Sir Robert Jones, K.B.E., C.B., T.D., from 1st Western General Hospital, to be Colonel, and to be granted the honorary rank of Major-General.

DIARY OF SOCIETIES AND LECTURES.

HUNTERIAN SOCIETY, Stion College, The Embankment, E.C., Wed., 9 p.m.—Mr. H. Tyrrell Gray: Obscure Intestinal Colic. Dr. A. R. Friel: Continuous Electric Current in Treatment.

MEDICAL SOCIETY OF LONDON, 11, Chandos Street, W.1.—Mon., 9 p.m., Mr. G. E. Gask: Lentsomian Lecture on Surgery of the Chest and Pleura.

MIDDLESEX HOSPITAL MEDICAL SCHOOL, W.—Emeritus Lectures, 3 p.m.—Tues. Dr. W. McC. Wanklyn: Future of the Medical Profession. Fri., Sir J. Kingston-Fowler: Treatment of Tuberculosis.

ROYAL COLLEGE OF PHYSICIANS, Pall Mall East, S.W.—Tues., 5 p.m., Dr. George Graham: Goulstonian Lecture—Glycaemia and Glycosuria. Thurs., 5 p.m., Dr. A. Whitfield: Lumléian Lecture—Etiology of Skin Diseases.

ROYAL SOCIETY OF MEDICINE.—Section of *Psychiatry*: Tues., 5.30 p.m., Dr. Henry Devine: Study of Hallucinations in a Case of Schizophrenia. Section of *Balneology and Climatology*: Thurs., 5.30 p.m., Discussion on Baths and Health Resorts in Gynaecology. Members of the Section, with guests, will dine together at the Welbeck Palace Hotel, Welbeck Street, W., at 7 p.m. Those intending to be present are requested to notify Dr. C. F. Sonntag, 80A, Belsize Park Gardens, N.W.3. Section of *Neurology and Ophthalmology*: Thurs., 8 p.m., Cases. Thurs. and Fri., 8.30 p.m., Discussion: Ocular Palsies, to be opened by Dr. Gordon Holmes and Mr. Leslie Paton, and continued by Mr. J. B. Lawford, Mr. H. S. Mayon, Mr. N. Bishop Harman, Mr. Foster Moor, Mr. W. H. McMullen, Mr. M. L. Hine, Dr. S. A. K. Wilson, and others. *Clinical Section*: Fri., 5 p.m., Cases.

ST. JOHN'S HOSPITAL, 49, Leicester Square, W.C.2.—Thurs., 6 p.m., Dr. K. Sibley: Chesterfield Lecture—Electrical Treatments.

POST-GRADUATE COURSES AND LECTURES.

GLASGOW POST-GRADUATE MEDICAL ASSOCIATION, Western Infirmary.—Wed., 4.15 p.m., Professor Monro and Sir Kennedy Dalziel: Medical and Surgical Cases.

HOSPITAL FOR SICK CHILDREN, Great Ormond Street, W.C.—Thurs., 4 p.m., Dr. C. E. Heald: Muscular Defects in Poliomyelitis.

LONDON HOSPITAL MEDICAL COLLEGE.—Lecture Demonstrations on Gonorrhoea: Mr. Clarkson, Tues. and Thurs., 4.30 p.m., Men; Dr. Simpson, Wed. and Fri., 4.30 p.m., Women.

MANCHESTER BABIES' HOSPITAL, Slade Lane.—Sat., 3.30 p.m., Dr. Chisholm: Therapeutic Value of Food Preparations.

MANCHESTER ROYAL INFIRMARY.—Tuesday, 4.30 p.m., Mr. H. H. Bayler: Surgical Disorders of Infancy and Early Childhood.

NATIONAL HOSPITAL FOR DISEASES OF THE HEART, Westmoreland Street, W.1.—Mon., 5.30 p.m., Dr. J. Parkinson: Dropsy.

NATIONAL HOSPITAL FOR THE PARALYSED AND EPILEPTIC, Queen Square, W.C.1.—Daily (except Wed. and Sat.) 2 p.m., Out-patient Clinics. Lectures: 3.30 p.m.—Mon., Mr. Scott: Disturbances of the Vestibular System; Tues., Dr. R. Russell: Syphilis of the Nervous System; Thurs., Dr. G. Holmes: Muscular Atrophy; Fri., 3.30 p.m., Dr. E. J. Reynolds: X-Ray Demonstration of Cases.

ST. MARY'S HOSPITALS, Manchester (Whitworth Street West Branch).—Fri., 4.30 p.m., Dr. Ward: Dyspepsia in Infancy.

SALFORD ROYAL HOSPITAL.—Thurs., 4.30 p.m., Dr. Jenkins: Examination of Sputum.

WEST LONDON POST-GRADUATE COLLEGE, Hammermith, W.—Daily, 10 a.m., Ward Visits: 2 p.m., In- and Out-patient Clinics and Operations. Mon., 2.30 p.m., Dr. Saunders: Medical Cases. Lectures—5 p.m., Mon., Dr. G. Stewart: Spinal Tumours; Tues., Dr. Pernet: Alimentary Tract and Morbid Skin Manifestations; Wed., Mr. Gibb: Glaucoma; Thurs., Dr. B. Spilbury: Aseptic Poisoning; Fri., Mr. Steadman: Dental Sepsis; Sat., noon, Mr. Sinclair: Surgical Diseases of Abdomen.

British Medical Association.

OFFICES AND LIBRARY, 429, STRAND, LONDON, W.C.9.

Reference and Lending Library.

THE READING ROOM, in which books of reference, periodicals, and standard works can be consulted, is open to members from 10 a.m. to 6.30 p.m., Saturdays 10 to 2.

LENDING LIBRARY: Members are entitled to borrow books, including current medical works; they will be forwarded, if desired, on application to the Librarian, accompanied by 1s. for each volume for postage and packing.

Departments.

SUBSCRIPTIONS AND ADVERTISEMENTS (Financial Secretary and Business Manager, Telegrams: Articulate, Westrand, London), MEDICAL SECRETARY (Telegrams: Madisecra, Westrand, London), EDITOR, *British Medical Journal* (Telegrams: Aitiology, Westrand, London).

Telephone number for all Departments: Gerrard 2630 (3 lines).

SCOTTISH MEDICAL SECRETARY: 6, Rutland Square, Edinburgh (Telegrams: Associate, Edinburg. Tel.: 4361 Central.)

IRISH MEDICAL SECRETARY: 16, South Frederick Street, Dublin (Telegrams: Bacillus, Dublin. Tel.: 4737 Dublin.)

Diary of the Association.

MARCH.

- 4 Fri. Edinburgh Branch: Winter Clinical Meeting, Royal Infirmary, 3.15 p.m. Lecture by Dr. J. S. Haldane, F.R.S., 5 p.m.; Dinner, Caledonian Station Hotel, 6.30 p.m.
- 8 Tues. London: Scrutiny Subcommittee, 2 p.m.
- 9 Wed. London: Finance Committee, 2.30 p.m.
London: Special Subcommittee as to Salaries of Laboratory Research Workers, Professors, and Teachers, 2.30 p.m.
City Division: General Meeting.
- 10 Thurs. London: Contract Practice Subcommittee, 2.30 p.m.
- 11 Fri. London: Standing Subcommittee of Central Ethical Committee, 2 p.m.
- 15 Tues. London: Propaganda Subcommittee, 2.15 p.m.
- 16 Wed. London: Joint Conference of Ministry of Health, Medical, Political, Hospitals, and Public Health Committees, 2 p.m.
- 18 Fri. North of England Branch, Mental Hospital, Ryhope, 3 p.m. Professor J. Middlemas: Incipient Insanity.
- 22 Tues. London: Public Health Committee (provisional).
- 23 Wed. London: Hospitals Committee, 2.30 p.m.
- 30 Wed. London: Medico-Political Committee (provisional).

APRIL.

- 14 Thurs. Worcestershire and Herefordshire Branch: British Medical Association Lecture by Mr. P. L. Daniel, F.R.C.S., on the Differential Diagnosis of Acute Abdominal Conditions.

APPOINTMENTS.

BURNELL-JONES, H. S., L.M.S.S.A., D.P.H.Oxon., Clinical Assistant, Venereal Diseases Department, General Hospital, and Honorary Anaesthetist, Dental Hospital, Birmingham.

CANDLER, A. L., M.B., B.S.Lond., F.R.C.S., Surgeon to the Royal Devon and Exeter Hospital.

COLYER, Stanley, M.D.Lond., M.R.C.P., Assistant Radiologist to the Royal Dental Hospital.

ROPER, Frank A., M.D.Camb., M.R.C.P.Lond., Physician to the Royal Devon and Exeter Hospital.

STANNUS, Hugh S., M.D., M.R.C.P.Lond., Physician to Out-patients, French Hospital, London.

TODD, Alan H., M.S., B.Sc.Lond., F.R.C.S.Eng., Assistant Surgeon to the Queen's Hospital for Children, Hackney Road, E.2.

BIRTHS, MARRIAGES, AND DEATHS.

The charge for inserting announcements of Births, Marriages, and Deaths is 9s., which sum should be forwarded with the notice not later than the first post on Tuesday morning, in order to ensure insertion in the current issue.

BIRTHS.

MAYNARD.—On February 23rd, at 1, Cleveland Gardens, W., the wife of Edwin Maynard, M.D., F.R.C.S., of 81, Oxford Terrace, Hyde Park, W., of a son.

PINSON.—On February 21st, at 155, High Street, Chorlton-on-Medlock, Manchester, to Lillie Mary, M.R.C.S., and K. B. Pinson, M.B., M.R.C.S.—a daughter.

VICKERY.—February 17th, 1921, at The Gleu, Fordingbridge, Hants, to Dr. and Mrs. E. P. H. Vickery—a son.

MARRIAGE.

RICHARDS-OLIVIER.—On December 21st, 1920, at St. Martin-in-the-Fields, by the Rev. Dr. Oxford, William Arthur Richards, M.B., B.S.Lond., to Noel Olivier, M.B., B.S.Lond.

DEATH.

HOWARD.—On February 25th, 1921, at Park Lane House, Macclisfield, Annie, the wife of Arthur Howard, M.B., Ch.B.

LONDON: SATURDAY, MARCH 12TH, 1921.

CONTENTS.

BRITISH MEDICAL ASSOCIATION.		PAGE	INSURANCE:	PAGE
PROCEEDINGS OF COUNCIL...	...	69	DISTRICT MEDICAL OFFICERS FOR SCOTLAND	74
DR. MACDONALD'S MISSION TO SOUTH AFRICA	...	70	CORRESPONDENCE	75
CURRENT NOTES:			DANGEROUS DRUGS REGULATIONS:	
WORK OF THE MEDICO-POLITICAL COMMITTEE	...	72	LETTER TO THE HOME SECRETARY	75
FEES FOR PRACTITIONERS CALLED IN BY MIDWIVES (SCOTLAND)	...	72	NAVAL AND MILITARY APPOINTMENTS	75
ASSOCIATION NOTICES:			DIARY OF SOCIETIES AND LECTURES	76
ELECTION OF COUNCIL, 1921-22	...	72	ASSOCIATION INTELLIGENCE	76
ELECTION OF REPRESENTATIVE BODY, 1921-22	...	73	APPOINTMENTS...	76
MOTIONS FOR ANNUAL REPRESENTATIVE MEETING, 1921	...	73	BIRTHS, MARRIAGES, AND DEATHS	76
BRANCH AND DIVISION MEETINGS TO BE HELD	...	73		
MEETINGS OF BRANCHES AND DIVISIONS	...	73		

British Medical Association.

PROCEEDINGS OF COUNCIL.

A MEETING of the Council was held at 429, Strand, London, W.C., on Wednesday, February 16th, 1921, with Dr. R. A. BOLAM in the chair. There were present:

Sir Clifford Allbutt (President), Dr. T. W. H. Garstang (Chairman of Representative Meetings), Dr. G. E. Haslip (Treasurer), Dr. T. Ridley Bailey (Staffs), Dr. J. A. P. Barnes (London), Sir James Barr (Liverpool), Dr. J. W. Bone (Luton), Dr. H. B. Brackenbury (London), Dr. H. C. Bristowe (Wrighton), Dr. C. Buttar (London), Mr. Russell Coombe (Exeter), Dr. J. Singleton Darling (Lurgan), Dr. James Don (Newcastle), Dr. R. Langd in Down (Hampton Wick), Mr. W. McAdam Eccles (London), Lieut.-Col. R. H. Elliot, Dr. A. C. Farquharson, M.P. (London), Dr. A. Forbes (Sheffield), Dr. E. R. Fothergill (Hove), Dr. H. A. Francis (London), Dr. J. Goff (Windlesham), Mr. N. Bishop Harman (London), Dr. I. W. Johnson (Bury), Dr. D. Lawson (Banbury), Sir R. H. Luce (Derby), Dr. J. A. Macdonald (Tamnton), Dr. S. Morton Mackenzie (Dorling), Major-General Sir William Macpherson (London), Dr. H. C. Mactier (Wolverhampton), Surgeon Captain E. H. Meaden (London), Dr. R. Peacocke (Dublin), Dr. C. M. Pearson (Edinburgh), Dr. F. Radcliffe (Oldham), Dr. D. Ross (London), Dr. D. A. Sheahan (Portsmouth), Dr. W. Johnson Smyth (Bournemouth), Dr. W. Snodgrass (Glasgow), Dr. F. O. Stedman (Weybridge), Dr. J. Stevens (Edinburgh), Dr. W. B. Crawford (Treasure (Cardiff), Mr. E. B. Turner (London), Dr. E. O. Turner (Bucks), Sir Jenner Verrall (Bath).

The Council resolved to send a special letter to Sir Dawson Williams, Editor of the BRITISH MEDICAL JOURNAL, expressing its gratification that the Editor's services to the medical profession, medical journalism, and the community had been recognized by the King. Congratulations on their knighthoods was conveyed also to Sir Squire Sprigge, Sir Charles Ryall, Sir William Hodgson, and Sir Alexander Jarvie Hood.

Dr. Macdonald's Visit to South Africa.

The Chairman, on behalf of the Council, welcomed Dr. J. A. Macdonald after his recent visit to South Africa on behalf of the Association, and drew attention to resolutions by South African Branches expressing appreciation of Dr. Macdonald's work and personality. Dr. Macdonald, at the Chairman's invitation, then gave the Council some account of his travels (a report of this appears in the SUPPLEMENT at page 70). The Council placed on record its deep appreciation of the great service rendered to the Association by Dr. Macdonald during his tour of the South African Branches as the Council's representative.

The Question of Federation.

The Council approved for publication the report to Divisions and Representative Body (since published in the SUPPLEMENT of March 5th, 1921) upon the steps to be taken whereby the British Medical Association may become in part a federation. The Council resolved to convene an extraordinary general meeting of the Association, to be held at Newcastle on July 19th, 1921, for adoption of the amended articles and by-laws enabling the Association to become in part a federation. Should the amended articles and by-laws be adopted on July 19th, a further extraordinary general meeting will be held at 429, Strand, London, on August 3rd, 1921, to confirm the adoption. The Council decided also that a conference on this subject should be held at the Head Office on July 5th,

at 10 a.m., and invitations are being sent to the Oversea Branches, the Federal Committees, and the Joint Organization Committee for Ireland. This conference, after consideration of the report and recommendations published in last week's SUPPLEMENT will (by instruction of the Council) report direct to the Annual Representative Meeting, with particular reference to the views expressed by the Oversea and Irish representatives.

Professional Secrecy.

Arising out of a recommendation of the Central Ethical Committee the Council expressed the following opinion:

1. That when a medical practitioner refuses to divulge information which he has obtained in the exercise of his professional duties in such circumstances as the following:

- (a) In a court of law when the court has ruled that the information so obtained must be disclosed;
- (b) Where it is already provided by Act of Parliament that he must do so, for instance, as in notification of certain diseases,

such action must be taken entirely on his own responsibility, and the Association could not be expected to support him or protect him from consequences he may incur in so doing.

2. That if attempts be made to add additional exceptions to the general rule of the profession as regards professional secrecy, the Association recognizes that it will be necessary, after due consideration (i) to resist by all lawful means any such encroachment, and (ii) where such encroachment is attempted, to accord support by any means in the power of the Association to any individual practitioner who may be assailed through such new encroachment.

Municipal Hospitals and Clinics.

The Ministry of Health Committee, in its report to the Council, submitted a number of recommendations as to the policy of the Association on the question of municipal hospitals and clinics. It was decided to call a joint meeting of the Medico-Political, Public Health, Hospitals, and Ministry of Health Committees, to consider the whole question of municipal hospitals and clinics. The drawing up of an agenda for this meeting was placed in the hands of the four chairmen concerned, who were further empowered to invite to the conference representative medical officers of health or others particularly interested in the setting up or administration of municipal hospitals or clinics.

On the subject of Poor Law hospitals and civil needs a series of proposals put forward by the Hospitals Committee was approved for recommendation to the Representative Body, together with a number of the resolutions passed by the Conference of Representatives of Medical Staffs of Voluntary Hospitals held on December 21st, 1920, and reported in the SUPPLEMENT of January 1st, 1921.

The Collective Opinion of the Profession.

The report of the Special Committee appointed to consider the formation of a Central Medical Representative Committee was received and discussed, with particular reference to the memorandum on this subject published in the SUPPLEMENT of February 19th, 1921. The Chairman undertook that the Committee would take into consideration the series of questions formulated by Dr. Fothergill, and since embodied in a letter by him printed in the

JOURNAL of March 5th. The Special Committee considering this subject now consists of Dr. Bolam (chairman), Dr. Garstang, Dr. Haslip, Dr. Brackebury, Sir Jenner Verrall, and Dr. E. J. Maclean. The Chairman stated that the Certifying Factory Surgeons' Association and the Poor Law Medical Officers' Association of England and Wales had already accepted the invitation to co-operate with the British Medical Association in forming such a representative medical committee as the Minister of Health had asked for. (Since then the Society of Medical Officers of Health has also accepted.) The Chairman of the Scottish Committee stated that his committee was of opinion that there should be a Scottish representative on the English Central Committee when set up, and an English representative on the analogous Scottish Committee. This and other points Dr. Bolam undertook to bring to the notice of the Special Committee.

Medico-Political.

The report of the Medico-Political Committee included reference to medical certificates of inability to attend school, fees for medical practitioners called in on the advice of midwives, notification of infectious diseases, fees and travelling allowances for medical witnesses, the Tasmanian Medical Act, and the organization of the Post Office medical officers. Arising out of this Committee's report the Council resolved that the British Medical Association should endeavour to obtain the best terms and conditions for medically qualified laboratory and research workers and professors and teachers, so far as possible in co-operation with the Association of University Teachers. With regard to medical attendance on miners' and other workers' families, it was resolved that free choice of doctor by patient and of patient by doctor should be a recognized principle in all forms of contract practice. It was agreed that the British Medical Association should co-operate with the Association of Certifying Factory Surgeons in an endeavour to obtain increased fees for these practitioners. As recorded in the SUPPLEMENT, the position with regard to the draft Regulations under the Dangerous Drugs Act, 1920, was laid before the Council by the Chairman of the Medico-Political Committee and Dr. J. W. Bone. The Council was informed of the modifications which the Home Office was prepared to grant, but declined to give any opinion as to the practicability of the modified Regulations until the new draft had been seen.

Public Health.

The Public Health Committee was instructed to prepare and submit to a future meeting of the Council a draft Parliamentary Bill providing security of tenure for medical officers of health. On the recommendation of the Committee the Council expressed its approval of a resolution passed in July, 1920, by the National Veterinary Medical Association of Great Britain and Ireland, deprecating the use of tuberculin by persons other than members of the medical and veterinary professions, and calling for immediate steps to control the standardization of tuberculin used in the diagnosis of tuberculosis in cattle.

Emergency Medical Organization.

The report of the Naval and Military Committee introduced to the Council a scheme, drawn up in outline by the Territorial Force Subcommittee, for the expansion of the Army Medical Service in the event of a national emergency. The Council resolved to remit the scheme for consideration and report by an *ad hoc* committee consisting of those members of the late Central Medical War Committee who are members of the Council, together with four representatives of the Naval and Military Committee.

DR. MACDONALD'S MISSION TO SOUTH AFRICA.

At the meeting of the Council of the British Medical Association on February 26th Dr. Macdonald gave an account of the visit he paid last autumn, at the request of the Council, to the South African Branches. A proposal to establish a South African Medical Association has recently been mooted, and Dr. Macdonald's first objective was the Medical Congress in Durban, Natal, where it was anticipated that this proposal would be discussed. Dr. Macdonald, who was cordially received by the Council, began the account of his visit by stating that he left Southampton on September 11th, 1920, by the *Walmer Castle*, and after an uneventful voyage reached Capetown, where the boat stopped for

a day. There he had the advantage of talking with Dr. Jasper Anderson and Dr. Darley Hartley. After leaving Capetown, stops were made at Port Elizabeth and East London, but at neither place did he go ashore, as the landing facilities at both were bad—by tender at the former, and by basket to the tender at the latter. Medical men journeying to the congress at Durban came aboard at both places.

At Durban, which was reached on October 2nd, he was met by the president of the Natal Coastal Branch of the Association, Dr. Campbell, whose guest he was during his ten days' stay in Durban. The Congress, of which Dr. Campbell was president, was an unqualified success, especially so when it was realized that in the whole of South Africa there are only some 600 to 700 members of the Association, separated by hundreds of miles; over 100 attended the Congress, the largest number that had attended any medical congress ever held in South Africa.

The Congress was run on the same lines as the Annual Meeting at home, with the usual papers, discussions, exhibitions, and entertainments, the latter displaying the lavish and whole-hearted hospitality characteristic of colonial life. On the scientific side the Congress was, he thought, a distinct success, the papers, judging from those he heard, being excellent; the discussions were keen and critical, with a more independent and self-reliant tone than was often heard at home; this characteristic had been notable also at the meetings he had attended during the visit he had paid to Australia and New Zealand in 1914 on behalf of the Association. The exhibition of instruments, drugs, etc., was good, and must have been very useful to practitioners coming from outlying places who had little chance of seeing modern developments in appliances, instruments, and so on.

So far as he was concerned, however, the most interesting aspect of the Congress was the medico-political. The constitution of the Congress was curious in that while it was under the aegis and management of the British Medical Association any medical practitioner could on payment of one guinea attend the meetings, take part in the discussions, and vote on any matter not specially connected with Association work. Many points were raised at the meeting, but the main interest centred in a proposal which had been made to form a Medical Association of South Africa; while the movers in the matter wished to drop the term "British," they expressed the hope that their association would be affiliated or federated to the British Medical Association. The movement originated in the Witwatersrand Branch, and the main reasons assigned for making the proposal were that the new association would not be hampered by the constitution of the British Medical Association, and that an association with the name Medical Association of South Africa would attract men who would not join an association bearing the name "British." A keen discussion took place, during which it appeared that the movers in the scheme proposed to form the new association into a trade union and register it as such. It seemed that it was in this matter that they considered they would be hampered by the constitution of the British Medical Association, and that they were of opinion that the British Medical Association could not undertake collective bargaining. The opinion of their own legal advisers on this point, together with the letters of the Medical Secretary on the subject, proved the latter opinion to be wrong. Dr. Macdonald said that he had been asked to take part in the discussion, but declined on the ground that the matter was one of internal politics in which the central authorities of the British Medical Association had no desire to force the hands of members in South Africa. He had, however, expressed his willingness to give any information he could as to the powers of the British Medical Association or restrictions imposed by its constitution. The discussion on the question whether a separate medical trade union for South Africa should be formed ended by the adoption of a resolution postponing the question until the next Congress, to be held at Capetown this year, and directing that in the meantime the British Medical Association Branches should be consulted and a plebiscite taken.

He had a most kind and flattering reception from the Congress, and every one seemed to vie the one with the other in their determination to make his visit a pleasant one; in this he had no hesitation in saying they had succeeded.

He gathered that there was considerable slackness in organization, and practically no rules concerning ethical procedure, owing probably to the effect of the war. He advised that instead of the Branches acting independently the position of the South African Committee should be strengthened with a view to its being used to settle disputes and conduct negotiations. He recommended also the formation of Divisions in the very large Branches; the appointment of a travelling secretary who would visit the outlying districts from which men had difficulty in attending any congress; the appointment of a correspondent or correspondents to keep alive the intercourse between the Central Office and the South African Branches. He had promised also to try and induce the Central Council to send out a delegate periodically to South Africa on such a mission as his.

From Durban he proceeded to Pietermaritzburg, through some magnificent scenery, one of the finest views he had ever seen being the Valley of a Thousand Kopjes. At Pietermaritzburg, where he was a guest of Dr. and Mrs. Campbell Watt, who made his stay very happy by their kindness, he had an equally hospitable reception. He attended a dinner given by the Administrator of Natal at which all the doctors of the locality were invited to meet him. A well-attended meeting of the profession was held, at which there was an interesting discussion upon the question of the proposed new association. Here again everyone seemed to lay themselves out to make his stay pleasant, and he might at once say that this was true of every place he stopped at.

The next stage of his journey was to Johannesburg. On the way he stayed for a day at Ladysmith, whence he took a car to visit the battlefields. While in Ladysmith he was able to meet all the medical practitioners there; he then went on through Elandslaagte, Majuba, Sand Spruit, among other places, to Johannesburg—a most interesting journey.

Dr. R. Mackenzie, C.M.G., President of the Witwatersrand Branch, with Mrs. Mackenzie, made his stay at Johannesburg like being at home. He had expected that the meeting here would be large, and was not disappointed, something like eighty practitioners being present. When the question of the proposal for a new association came up for discussion he was asked to make a statement from the British Medical Association point of view; this he did, and had expected a keen discussion. In this expectation, however, he was disappointed, the discussion being practically confined to a speech by Dr. Napier in favour of the new association. He (Dr. Macdonald) had no difficulty in correcting the inaccuracies contained in this speech, and the discussion then ended. He understood that at a subsequent meeting of the South African Medical Association only seven practitioners were present. While at Johannesburg he paid a visit, under the guidance of Dr. Watkins-Pitchford and Sir Spencer Lister, to the South African Institute, which is devoted to medical research. The system of investigating and recording the incidence and progress of pulmonary silicosis among workers in the Rand mines was fully explained to him, as were the mode of preparation and results of the vaccine which had been used with success in the treatment of pneumonia complicated by influenza.

From Johannesburg he went to Pretoria, where there was a big meeting of the profession, at which some Dutch practitioners were present; it was held under the chairmanship of Dr. Gairdner, President of the Branch.

While at Johannesburg he had visited the gold mines, and at Pretoria one of the medical men drove him to the Premier Diamond Mine, where the Cullinan diamond was found. It was a curious mine, being merely a big hole in the ground, out of which some 93 million tons of gravel and clay had been excavated. He arrived just at the midday blasting, when in the course of two or three minutes there were some 2,500 explosions. During his stay in Pretoria he had an interview with General Smuts, the Premier, having received an introduction through the kindness of Dr. Peter Macdonald of York.

On the way back to Johannesburg he attended a meeting at Bloemfontein, where he met with the only rain of any consequence which fell during his visit to South Africa. The meeting there was not so well attended as others, owing probably to the short notice and the absence of the President, Dr. Manning. The discussion on the new association, however, was very keen, and there

appeared to be more support for the idea than at any place he visited.

The journey to East London took him through the veldt, which consisted of hundreds of miles of sandy plains—very poor ground and very poor cattle. He was told, however, that had he been a fortnight later he would have found the district covered with grass and flowers. East London, where he stayed with Dr. and Mrs. Bruce-Bays, was a charming seaside place. There was a good meeting of the local medical profession, at which very little sympathy was shown for a South African medical trade union.

Journeying from East London to Grahamstown he had his first experience of travelling by car over the veldt, and though the road was mostly such as an Englishman would scarcely trust his car on, the first eighty miles of the distance, to Breakfastlei, were covered at some twenty miles an hour. This journey, which was through Kaffirland proper, was very interesting, affording many varied glimpses of Kaffir life. At Breakfastlei he was met by two practitioners from Grahamstown, who took him the rest of the journey to that town through some wonderful scenery. Grahamstown, where he was entertained by Dr. Dru Drury, appeared to be the most English town of all those he visited in South Africa. It was a great educational centre and a cathedral city. The meeting of the profession there showed very little sympathy with the idea of a new association. He went with Dr. Dru Drury and Dr. Griffiths from there through fine scenery to Port Elizabeth, and was present at an excellent meeting, which was attended by every practitioner in Port Elizabeth. On his advice it was decided to form a Division at Port Elizabeth, since communication between it and Grahamstown is difficult.

From Port Elizabeth he went on to Capetown by the Garden Route through very beautiful scenery. There was an excellent meeting, at which no sympathy was shown with the idea of a South African medical trade union. During his week's stay in Capetown he enjoyed some very fine drives, and was entertained most hospitably.

From Capetown he went to Kimberley, where the kindness of the profession made his stay very pleasant. Dr. Symons, the President of the Branch, Dr. Lewis Jones, Dr. Wicks, and Mr. Grimmer, assistant manager of the de Beers Mines, doing everything possible for him. The meeting of the medical profession, which was well attended, showed very little sympathy with the idea of a new association. From Kimberley he travelled north into Rhodesia and reached Bulawayo, where Drs. Eaton and Forrester, the President and Secretary of the Rhodesian Branch, looked after his comfort very kindly, and he had the opportunity of meeting most of the doctors of the district. He visited Rhodes's grave on the Matoppoos, where also was the grave of Dr. Jameson and the memorial to Major Alan Wilson and the men who died at Shangani. From Bulawayo he went on to the Victoria Falls, a wonderful place, where he spent a few days. During a trip of some ten miles by motor boat on the Zambesi he saw five hippopotamuses and about a dozen crocodiles. Returning from Victoria Falls to Bulawayo, he went on to Salisbury, where Dr. and Mrs. Fleming were particularly kind to him, and the Deputy Administrator of Southern Rhodesia put a car at his disposal, and showed him great kindness generally. The meeting here was one of the best, considering the small number of medical men in the district. Some travelled about one hundred miles by car to attend the meeting.

For himself personally, the tragedy of the trip was that he had been disappointed in his hope of traversing the whole of the Cape to Cairo route by land, going through Tanganyika, Nairobi, Entebbe, to the Nile, and so to Khartoum and Cairo. Difficulties were raised about the journey, and he read in the newspapers that objections were made to a British subject penetrating the Belgian Congo at that time. He had therefore reluctantly abandoned the project, only to receive on his return home a letter from Dr. C. A. Wiggins of Entebbe, stating that the profession there was very disappointed, having made arrangements to convey him from Entebbe to the Nile, arrangements of which he did not know until he received Dr. Wiggins's letter. From Capetown he came home by the *Kenilworth Castle*.

The advice he had given as to the organization of the profession, during his visits to the various centres, had been

mainly on the lines of strengthening the position of the South African Committee, and making use of it for dealing with disputes, etc.—the establishment on both sides of more regular correspondence between the Central Office and South Africa, and the bringing into existence there of a set of ethical rules.

He was everywhere shown the greatest kindness, and the hope was expressed repeatedly that he would persuade the Council to arrange more such periodical visits. He felt that such a course was desirable, especially when it was realized that in two years the universities in South Africa would be beginning to confer their own degrees; students would then no longer have to come home for a degree or diploma, and the risk of the profession in South Africa becoming estranged from the profession at home would thereby be increased.

The CHAIRMAN called the attention of the Council to two communications received from South African Branches—the one from the Witwatersrand Branch, transmitting a resolution adopted on November 25th, 1920, thanking the British Medical Association in England for sending a man of Dr. Macdonald's outstanding ability, tact, and courtesy to visit the Branch; the other was from the Eastern Province Branch, enclosing a copy of two resolutions adopted on November 29th. The first thanked the Central Council for giving the Branch the advantage of meeting Dr. Macdonald and hearing his explanation of the relation of Overseas Branches to the parent Association; the second stated that the Branch could see no advantage in forming a Medical Association of South Africa, and was resolved in every way to maintain and strengthen the British Medical Association.

On the motion of Sir JENNER VERRALL, seconded by Dr. T. W. H. GARSTANG, Chairman of Representative Meetings, the Council unanimously adopted a resolution placing on record "its deep appreciation of the great service rendered to the Association by Dr. Macdonald in his recent visit to the South African Branches as the Council's representative."

British Medical Association.

CURRENT NOTES.

Work of the Medico-Political Committee.

AT the last meeting of the Medico-Political Committee a number of important matters were under discussion: (1) The question of payment for certificates for children who are unable to attend school was considered, and it was decided to recommend the Council to inform all local education authorities that, in the opinion of the Representative Body, such certificates should be paid for by the authority requiring them and that a form of certificate should be provided for the purpose. The Council has approved the recommendation, and the necessary action is being taken. (2) The question of motor car taxation was also considered, and it was decided, with the approval of the Council, to back up the effort of the Automobile Association and Motor Union to obtain the substitution of a flat rate tax on petrol for the present £1 per horse-power tax. (3) At its September meeting the Committee decided to ask the Civil Service Commissioners to raise to one guinea the fee now paid in respect of the examination of candidates for the Civil Service. The Civil Service Commissioners have refused to accede to the request, but the Committee is pressing them to reconsider the decision. (4) As a result of action taken at the September meeting, the Board of Customs and Excise has informed the Association that pensions officers who send applicants for pensions for blindness to obtain certificates of blindness from honorary officers of voluntary hospitals are not acting in accordance with the spirit of the instructions issued to them under the Act. (5) The Council has approved a recommendation by the Committee that the Association should endeavour to obtain the best possible terms and conditions for medically qualified laboratory and research workers and professors and teachers, in co-operation with the Association of University Teachers, and a subcommittee is now considering the matter. (6) Further consideration was given to

the fee for notification of infectious diseases, and it was decided to seek the assistance of the Committee of Medical Members of Parliament with a view to the early restoration of the pre-war fee. (7) The Council has approved the Committee's recommendation that the British Medical Association should co-operate with the Association of Certifying Factory Surgeons with a view to obtaining an increase in their fees. (8) The new rates for telephone service were considered, and the Committee, while regretting the increase, was of opinion that, assuming an increase to be necessary, this will not weigh more heavily on medical men than on other classes of telephone subscribers; the Committee, therefore, did not consider that there were sufficient grounds for making a special complaint.

Fees for Practitioners called in by Midwives (Scotland).

Some time ago the Scottish Committee, at the request of the Scottish Board of Health, submitted a revised scale of fees for practitioners called in by midwives. The scale proposed that (a) a flat rate of £2 2s. be paid for all emergencies arising during or immediately after parturition and should include responsibility for attendance during ten days after confinement; (b) £1 1s. for anaesthetist's fee; (c) £2 2s. for abortion or miscarriage, and (d) 5s. for a single day visit and 10s. 6d. for a night visit. At a conference between the Board and the Chairman's Subcommittee, held on February 25th, the Board intimated that under the Midwives (Scotland) Act, 1915, it was precluded from paying an inclusive fee to cover more than one subsequent visit, and it asked the Committee to reconsider the scale in the light of that, and to submit proposals on the lines of the English scale but including only one subsequent visit.

The Scottish Committee, at a meeting on March 4th, reconsidered the matter, and, having in view the prevailing fees charged for midwifery in private practice, and the decision of the Representative Body that a fee of £2 2s. is not sufficient in cases where operative interference is required, the Committee decided to submit the following scale to the Board, namely:

	£	s.	d.
(1) Fee for all attendances of a doctor during parturition (that is, from commencement of labour until the child is born), whether operative assistance or not is involved, including attendance during the third stage and including one subsequent visit	2	2	0
(2) Fee for attendance of a second doctor to give an anaesthetic	1	1	0
(3) Fee for suturing the perineum, for the removal of adherent or retained placenta, for exploration of the uterus, for the treatment of <i>post-partum</i> haemorrhage, or for any operative emergency arising directly from parturition, including one subsequent necessary visit	1	1	0
(4) Fee for attendance at, or in connexion with, an abortion or miscarriage, including one subsequent necessary visit	2	2	0
(5) Fee for visits to mother or child not included under (1) to (4):			
Day (9 a.m. to 8 p.m.)	0	5	0
Night (8 p.m. to 9 a.m.)	0	10	0
No fee to be paid for subsequent visits during the first ten days after parturition in a case where the doctor has already attended and been paid under (1), (3), and (4).			
(6) The usual mileage fee of the district to be paid for all attendances.			

It was agreed to suggest to the Board that practitioners called in in an emergency should give an honourable undertaking to give all necessary visits during the first ten days without additional charge.

Association Notices.

ELECTION OF COUNCIL OF ASSOCIATION, 1921-22.

A LIST of the Groups of Branches in the United Kingdom for election of twenty-four Members of the Council, 1921-22, and *Nomination Form*, are printed below. The *Nominations* must be in the hands of the Medical Secretary **by May 16th**.

The result of the election for Members of Council by the Groups of the Oversea Branches was published in the SUPPLEMENT of February 19th, 1921.

GROUPS OF HOME BRANCHES FOR ELECTION OF TWENTY-FOUR MEMBERS OF THE COUNCIL, 1921-22.

(Each Group elects One Member of Council unless otherwise stated.)

- | | |
|---|--|
| BRANCHES IN GROUP (A) —
North of England
North Lancashire and South
Westmorland | BRANCHES IN GROUP (J) —
Dorset and West Hants
South-Western
Wiltshire |
| BRANCHES IN GROUP (B) —
Yorkshire | BRANCHES IN GROUP (K) —
Oxford and Reading
Southern |
| BRANCHES IN GROUP (C) —
Lancashire and Cheshire
(Two to be elected) | BRANCHES IN GROUP (L) —
Kent
Surrey
Sussex |
| BRANCHES IN GROUP (D) —
East York and North Lincoln
Midland | BRANCHES IN GROUP (M) —
Aberdeen
Dundee
Northern Counties
Perth |
| BRANCHES IN GROUP (E) —
Cambridge and Huntingdon
Essex
Norfolk
South Midland
Suffolk | BRANCHES IN GROUP (N) —
Edinburgh
Fife |
| BRANCHES IN GROUP (F) —
Birmingham
Staffordshire | BRANCHES IN GROUP (O) —
Glasgow and West of Scotland
(Four City Divisions) |
| BRANCHES IN GROUP (G) —
North Wales
Shropshire and Mid Wales
South Wales and Monmouth-
shire | BRANCHES IN GROUP (P) —
Border Counties
Glasgow and West of Scotland
(Five County Divisions)
Stirling |
| BRANCHES IN GROUP (H) —
Metropolitan Counties
(Four to be elected) | BRANCHES IN GROUP (Q)
Connaught
South-Eastern of Ireland |
| BRANCHES IN GROUP (I) —
Bath and Bristol
Gloucestershire
West Somerset
Worcestershire and Here-
fordshire | BRANCHES IN GROUP (R)
Leinster |
| | BRANCHES IN GROUP (S) —
Munster |
| | BRANCHES IN GROUP (T) —
Ulster |

FORM FOR NOMINATION

BY A DIVISION, OR BY THREE MEMBERS OF A BRANCH, IN THE GROUP, OF A CANDIDATE FOR ELECTION AS ONE OF THE TWENTY-FOUR MEMBERS OF THE COUNCIL, 1921-22, TO BE ELECTED BY THE GROUPED HOME BRANCHES.

* By instruction of the Division I (* or We, the undersigned Members of the Branch) hereby nominate

..... of

as a Candidate for Election by the Branches in Group† as a Member of the Council of the Association.

.....Honorary Secretary.*
.....Division.*
(.....Member.*
.....Member.*
.....Member.*)

I hereby declare my willingness to serve, if elected, as a Member of the Council for the year 1921-22.

Candidate's Signature.....

N.B. — The Nominations must be in the hands of the Medical Secretary, 429, Strand, London, W.C.2., by **May 16th**. The above form may be used, or, if preferred, a separate form will be sent on application to the Medical Secretary.

* Please omit words not required. In the case of a nomination by members, the nomination, to be valid, must be signed by at least three members.

† The Group should be indicated by filling in the index letter (as above).

ELECTION OF REPRESENTATIVE BODY OF ASSOCIATION, 1921-22.

Constituencies in Representative Body.

THE Council has finally grouped the **Home Divisions** for election of the Representative Body, 1921-22, in the same manner as for 1920-21, except that the **Caithness and Sutherland Division** of the Northern Counties of Scotland Branch, and the **Rotherham and Sheffield**

Divisions of the Yorkshire Branch, have been made independent Constituencies.

As intimated to all the **Oversea Bodies**, the Council has made each Oversea Division and Division-Branch an independent Constituency.

Election of Representatives and Deputy-Representatives.

The REPRESENTATIVES AND DEPUTY-REPRESENTATIVES in the Representative Body must be elected not later than **June 17th**, and their names notified to the Medical Secretary **not later than June 24th**. The Annual Representative Meeting at Newcastle begins on July 15th.

Special attention is drawn to the fact that the election of Representative(s) and Deputy-Representative(s) may, at the discretion of the Constituency, be carried out by General Meeting of the Constituency, or by postal vote.

MOTIONS FOR ANNUAL REPRESENTATIVE MEETING, NEWCASTLE, JULY, 1921.

NOTICES OF MOTION by Divisions, Constituencies, or Branches, for the consideration of the Annual Representative Meeting of the Association, commencing Friday, July 15th, 1921, proposing to make any addition to, or any amendment, alteration, or repeal of, any Article or By-law, or to make any new Article or By-law, or proposing material alteration of the policy of the Association in matters relating to the honour and interests of the profession or of the Association, must be published in the **BRITISH MEDICAL JOURNAL SUPPLEMENT** not later than **May 14th**, and for this purpose should be received by the Medical Secretary **not later than April 30th**.

LIBRARY OF THE BRITISH MEDICAL ASSOCIATION.

A LIST of periodical publications, official reports, and Blue Books in the Library of the British Medical Association available for issue to members on loan has been printed, and copies can be obtained free on application to the Librarian at the house of the Association, 429, Strand, W.C. The regulations governing the loan of these publications are stated in the introduction to the list. The Library is open for consultation from 10 a.m. till 6.30 p.m. (on Saturdays 10 a.m. till 2 p.m.).

BRANCH AND DIVISION MEETINGS TO BE HELD.

METROPOLITAN COUNTIES BRANCH: MARYLEBONE DIVISION.—A meeting of the Division will be held at 8.30 p.m. on Wednesday, March 16th, at 11, Chandos Street. Agenda: Election of two Representatives of the Division on the Branch Council any nominations for Representatives should reach the Honorary Secretaries by first post, March 15th). Address by Dr. T. Watts Eden, F.R.C.P., on "Some notes on the treatment of private patients in hospitals in the U.S.A. and Canada."

METROPOLITAN COUNTIES BRANCH: WILLESDEN DIVISION.—A meeting of members and non-members will be held on Tuesday, March 15th, at 8.30 p.m., at St. Andrew's Parish Hall, High Road, Willesden Green, N.W. (1) Report on conference with Willesden District Council, etc. (see **BRITISH MEDICAL JOURNAL SUPPLEMENT**, March 5th, 1921). (2) Consider formation of "Practitioners' Mutual Help Scheme" on lines of Sheffield Division. (3) Clinical meetings and medical club.

WORCESTERSHIRE AND HEREFORDSHIRE BRANCH.—A meeting of the Branch will be held at the Feathers Hotel, Ledbury, on Thursday, April 7th, at 3.15 p.m., when a British Medical Association lecture will be given by Mr. P. Daniel, F.R.C.S., Surgeon to Charing Cross Hospital, on "Differential diagnosis of acute abdominal conditions from a clinical standpoint." A discussion will follow. The Branch Council will meet at 3 p.m.

Meetings of Branches and Divisions.

JOINT MEETING OF NOTTINGHAM DIVISION AND NOTTINGHAM MEDICO-CHIRURGICAL SOCIETY.

A JOINT meeting of the Nottingham Division of the British Medical Association and the Nottingham Medico-Chirurgical Society was held on March 2nd, with Dr. J. P. BLURTON, President of the Society, in the chair. The MEDICAL SECRETARY, by invitation of the two societies, addressed the meeting on "Some of the difficulties of a medical organizer." He detailed a considerable number of obstacles that he had met during the thirty years he had been interested in medical organization. The chief of these was the fact that nobody liked to be organized, least of all the medical man, for it meant some sacrifice of individuality. But the profession had for the

last twenty years been going through a process of intensive education, and was finding out that if it wanted to maintain its influence in public affairs and to preserve its status it must be organized for those purposes. He dealt with the atmosphere of suspicion of leaders which was a marked feature of all organizations; it was due not to any special dose of original sin in the medical profession, but to the imperfection of human nature. The average man did not understand democratic government; he did not realize that in selecting a man to represent him he necessarily must repose trust in him; on the contrary, he was inclined to resent action by his representatives because he did not, and could not, know all the factors which had influenced his representatives. This suspicion led to sensitive men declining to have anything to do with medical politics, and thereby the profession was deprived of the services of some of its best intellects. Dr. Cox also dwelt on the difficulty of reconciling the various interests inside the profession, and pointed out that no body other than the British Medical Association was capable of doing this, because no other body comprised and catered for all sections as the Association did. He said that up to the present time the consultant element of the profession had rather held aloof from medical politics, with a few brilliant exceptions, but that economic and other factors were forcing them to see that they also must have an organization which must be able to place the force of the whole organized profession at the back of any section which needed it at any particular time. The entry of the hospital physicians and surgeons and medical teachers into medical politics would be a great gain to all.

Dr. Cox urged members to take a proper pride in the Association; this, if properly developed, would make the Association a much greater force than it now was. If doctors could be induced to take the long view, both backwards and forwards, they would perceive that the Association had done great work for every section of the profession, was now more thoroughly equipped for that work than ever it had been, and that its future possibilities were unbounded. He was not at all pessimistic about the future of medical organization. The difficulties he had alluded to in his address were mainly due to the fact that the medical profession had only recently begun to realize the necessity for organization, as, up to twenty years ago, doctors had mainly had to deal as individuals with individuals, and did not need an organization for that purpose. The position was so changed nowadays, when all kinds of doctors were continually dealing with organized bodies of lay people, that the difficulties of a medical organizer were bound to get less as the necessity for, and the good results obtained from, organization became more apparent.

After several questions had been asked and answered, Dr. HOUFTON proposed and Dr. J. H. COX seconded a vote of thanks to Dr. Alfred Cox, which was carried very heartily.

LANCASHIRE AND CHESHIRE BRANCH: BURY DIVISION.

A MEETING of the Bury Division was held on February 2nd to consider the Consultative Council's interim report. Dr. TURNBULL was in the chair. The discussion, in which all took part, was introduced by Dr. I. W. JOHNSON. The advantages were felt to be: (1) Work would be in the hands of the general practitioner. (2) Every general practitioner would have the right to attend his own patients in an institution and have the advantages of institutional treatment, with the right to demand specialist treatment for such cases as needed it. The disadvantages were felt to be (1) the great cost, (2) opposition by present whole-time and part-time men adversely affected. A resolution approving the general principles of the scheme was unanimously adopted. A further resolution was passed appointing the Executive of the Division an Advisory Committee provisionally with power to co-opt members to safeguard the interests of the profession in any developments of the subject occurring within the area of the Division.

A MEETING of the Bury Division was held on February 24th, with Dr. TURNBULL in the chair. The HONORARY SECRETARY read the correspondence relating to the Dangerous Drugs Regulations, including the latest information available in the Assistant Medical Secretary's letter of February 21st. A general discussion ensued. On the motion of Dr. COOK, seconded by Dr. YOUNG, it was unanimously resolved:

The Bury Division of the British Medical Association, having read and discussed the proposed Regulations for the sale of dangerous drugs, emphatically protests against the application of these, or any similar regulations, to registered medical practitioners.

The Secretary was instructed to forward a copy of the resolution to the Home Office, the Ministry of Health, the British Medical Association, and the M.P. for Bury. Arrangements were also made with local secretaries and others to forward a copy to M.P.'s of other parliamentary divisions within the area of the Division, and the Secretary undertook to furnish copies of the resolution for this purpose to Drs. Lawrie, J. P. Stuart, and C. Crawshaw. The action of the Association in dealing with the Dangerous Drugs Regulations was criticized on the ground that, instead of devoting its time to getting details amended, the Council should make it plain that what the medical profession required was to be exempt and entirely outside the scope of any such regulations. Dr. NUTTALL proposed the following resolution, which was seconded by Dr. YOUNG, and unanimously carried:

That the Bury Division of the British Medical Association is of the opinion that the concessions mentioned in the Assistant Medical Secretary's letter of February 21st are utterly inadequate and do

not cover the objections to the draft Regulations, and requests the British Medical Association to call upon the Home Office to withdraw these draft Regulations unconditionally, in so far as they relate to registered medical practitioners.

A copy of the resolution was directed to be sent to the Medical Secretary of the British Medical Association.

Several members spoke on the subject of the new pink monthly certificates for insured persons, and described the difficulties they had experienced in obtaining from their respective Insurance Committees sufficient copies of them for their requirements. On Dr. J. HOLMES'S motion it was decided to bring the matter to the notice of the Insurance Acts Committee of the British Medical Association, in order that that Committee might use its influence to get a better supply for insurance practitioners.

MALAYA BRANCH.

At a meeting of the Malaya Branch of the British Medical Association at Kuala Lumpur, Selangor, Federated Malay States, in October, 1920, a paper was read by Dr. A. J. McCLOSKEY, S.M.O. Selangor, on the effect of the control and rationing of rice on beri-beri. He pointed out that control of rice came into force early in July, 1919, and rationing in January, 1920, in Perak, and in February, March, and April, 1920, in different parts of Selangor, and in 1920 he had found a marked reduction of the number of beri-beri cases admitted to hospital. The figures were: for Perak, in 1919, 504 cases of beri-beri treated, in 1920, 57 cases; or in 1919, 2.2 per cent. of the total of all diseases, in 1920 of 0.2 per cent. For Selangor, the corresponding figures were 673 cases in 1919, 173 in 1920, or 4.21 per cent. of all diseases treated, to 0.9 per cent. The rice consumed in Selangor and Negri Sembilan during 1919 and first two months of 1920 was Siam rice; since February, 1920, the rice consumed in Selangor has been all Rangoon and in Negri Sembilan mostly Rangoon. In Perak mostly Rangoon rice was consumed during the whole of 1919 and 1920, and in this State was found the lowest percentage of beri-beri during 1919, verifying the fact as stated by Fraser and Stanton that Siam rice was considerably more potent in its beri-beri-producing power than Rangoon rice. The control and rationing of rice had varied the rice used not only in quantity, but in kind and variety, and the reduced rice ration was supplemented by other articles of diet such as sweet potatoes and wheat flour, and in this way prevented the occurrence of beri-beri. The Siam rice consumed in 1919 was of a broken variety and not highly polished.

METROPOLITAN COUNTIES BRANCH: CITY DIVISION.

A MEETING of the City Division was held on March 2nd at the Metropolitan Hospital, Kingsland Road, N., when Dr. CUTHBERT DIXON was in the chair. There was a good attendance. Mr. W. MCADAM ECCLES delivered a comprehensive and helpful lecture on the early diagnosis of acute abdomen, which was greatly appreciated. An animated discussion followed, and the proceedings came to a close with a very hearty and unanimous vote of thanks to Mr. Eccles.

NORFOLK BRANCH: EAST NORFOLK DIVISION.

A MEETING of the East Norfolk Division was held at Norwich on March 1st. It was decided that as all the Poor Law authorities had increased the district medical officers' salaries by 12 to 33 per cent., no further increase should be asked for at present. Several of the members were of the opinion that the work was decreasing. It was reported that the fee for attendance upon pauper women in confinement was in many cases inadequate. A resolution was passed requesting the guardians to adopt a universal fee of £2.

The following protest was sent to the Home Office:

This Division of the British Medical Association protests against any Regulations which affect medical men being issued without the profession being previously consulted.

INSURANCE.

DISTRICT MEDICAL OFFICERS FOR SCOTLAND.

THE Scottish Board of Health announces that it has appointed the following medical men to be District Medical Officers:

Senior District Medical Officers.—Western District (Headquarters, Glasgow): R. Buchanan, M.B., C.M., D.P.H. South Eastern District (Headquarters, Edinburgh): A. M. McIntosh C.M.G., M.B., Ch.B., F.R.C.S.

Junior District Medical Officers.—South-Western District (Headquarters, Glasgow): John Gilmonr, M.B., C.M., F.R.C.S. D.P.H. Northern District (Headquarters, Aberdeen): John Jeffrey, M.B., Ch.B., F.R.C.S. Eastern District (Headquarters Dundee): J. Murray Young, M.B., C.M.

These officers will act as Medical Referees in case referred to them on questions of incapacity of insure persons for work and as consultants in giving second opinions on questions of diagnosis and treatment. They have also administrative duties in connexion with the Insurance Medical Service and other work of the Scottish Board of Health.

CORRESPONDENCE.

The New System of Medical Records.

SIR,—From reading the correspondence on the new system of medical records it is clear that there are two sides—a majority who view them with more or less disfavour and a minority who take the opposite view. I am inclined to think that the latter consist of those who have small panels and those who have very large ones. These last, no doubt, are fortunate to have dispensers who can relieve them of all the dispensing and book-keeping connected with their private practice, and so give them time to ferret out the record cards.

Speaking as a country practitioner who has to do all his own dispensing, both for private patients and insured patients in rural areas, I regard them as an unmitigated nuisance and from a clinical point of view quite useless. Holding as I do other appointments, I am appalled at the time nowadays which is taken up and wasted in what I term ink splashing.

We are provided with record envelopes often incorrectly addressed, and on the assumption that everybody brings his or her medical card with them, whereas it is the exception for them to do so and not the rule. In country districts it is not uncommon to have twenty or thirty patients with the same surname, and it is hardly to be expected that we can remember everybody's Christian name; and so if, say, out of twenty patients called Pike we enter the details of one of them on the envelope of another Pike in error, we are not provided with spare envelopes to replace the defaced one. What will happen when we take our holidays, and locums who are strange to the district replace us, Heaven only knows. When we visit a patient we spend our time finding out his age, occupation, married or single, which is annoying to both doctor and patient?

In the numerous letters that have been written on this subject I have not seen any reference to one most important point from the patient's point of view, and that is that the time taken up in taking out the record envelope from its file and filling up the details diverts the mind of the doctor from concentrating his attention on the diagnosis and treatment of his patient. You cannot have it both ways. One cannot imagine what would happen in a time of a bad influenza epidemic. This winter has been a comparatively healthy one, and even so many of us have to fill in our records after evening consulting hours when we should be resting.

If, however, some form of records is bound to stay, I agree with the letter of Dr. Manson in to-day's SUPPLEMENT that every insurance practitioner should carefully consider the alternative proposals of Dr. T. Wood Locket, as outlined in his letter of February 19th. It is certainly a most excellent and well-thought-out idea.—I am, etc.,
Gilligham, Dorset, March 5th. R. W. MORGAN, M.D.

DANGEROUS DRUGS REGULATIONS.

WE printed last week in the SUPPLEMENT the letter received by the Medical Secretary from Sir Edward Troup, Permanent Under-Secretary of State in the Home Office. The following joint reply was forwarded to the Home Secretary on March 3rd. It was signed by the Medical Secretary of the British Medical Association, the Secretary of the Pharmaceutical Society of Great Britain, the Vice-Chairman of the Scottish Pharmaceutical Federation, the President of the Pharmaceutical Society of Ireland, and the Secretary to the Parliamentary Committee of the Co-operative Congress.

March 3rd, 1921.

SIR,

Your letter of the 25th directed to the signatories of the letter of the 22nd February respecting the Regulations issued under the Dangerous Drugs Act, 1920, was considered to-day at a full meeting of the signatories, which passed the following resolution:

This meeting learns with grave concern the unwillingness of the Home Secretary to appoint an expert committee to advise him before he makes the Regulations under the Dangerous Drugs Act, and resolves to take every step to bring to the notice of Parliament the absolute necessity for the appointment of such a committee.

The meeting appointed a small subcommittee, consisting of the signatories to this letter, and instructed us to bring to your notice the following observations.

It is by no means the intention of any of the bodies which have approached you on this subject to dictate to you the form of the Regulations. On the contrary, we

unreservedly recognize your responsibility for carrying out the objects of the International Opium Convention, and we do not suggest that you should enter into any process of bargaining between the conflicting interests. What we do press for most earnestly is, that in making the Regulations which will govern the dealings of large numbers of people with very important drugs, you will be guided by people who know what the difficulties are, have considered the points of view of the various sections concerned in dealing in these drugs, and more especially have tried to combine these views in such a way as to convince you that no section has been overlooked, and that the public interest will be conserved.

We would most respectfully suggest that you should reconsider this question of the appointment of a committee. We do not ask that the committee shall be a committee representative of the different interests. We ask that it should be composed of persons who have sufficient knowledge of the technical points, including the legal points, to enable them to appreciate the representations of persons representing the various interests involved.

We feel sure that such a process would not lead to any waste of time but rather that it would be a much quicker process than the one suggested in the last paragraph of your letter of the 25th ult. Moreover, it would enable the various bodies concerned to place their views before the committee in the presence of each other and so give the committee which would advise you every opportunity for reconciling as far as possible the different points of view.

We believe, Sir, that you have no conception of the strong resentment which has been caused by the publication of the draft Regulations without previous effective consultation with bodies that are deeply and legitimately interested in dealings with dangerous drugs. We are anxious to assist you in arriving at Regulations which, while meeting the main object for which such Regulations have to be devised—namely, the control of illicit traffic in these drugs—will be as little onerous as possible.

We believe that our suggestion of a committee advising you after having heard what can be said by the bodies concerned will be the best and the quickest way of enabling practical Regulations to be made.

Naval and Military Appointments.

ROYAL NAVAL MEDICAL SERVICE.

The following appointments are announced by the Admiralty: Surgeon Captain D. W. Hewitt, C.B., C.M.G., to the *President*, for hospital ship *Panama*. Surgeon Commanders J. W. Craig to the *Orion*, as Squadron Medical Officer, L. Lindop to the *Hawkins*.

ARMY MEDICAL SERVICE.

Colonel Lancelot P. More is placed on half-pay April 1st, 1920 (substituted for notification in the *London Gazette*, January 27th, 1921).

ROYAL ARMY MEDICAL CORPS.

Major T. E. Harty, D.S.O., relinquishes the acting rank of Lieutenant-Colonel.

Major C. Kelly, M.C., is placed on the half-pay list on account of ill health.

Major J. B. Clarke retires on retired pay.

Temporary Major J. H. Spencer to be Captain, January 25th, 1912, but not to reckon for pay or allowances prior to June 1st, 1920, with precedence next below R. O. Kelly, and to retain the temporary rank of Major (substituted for notification in the *London Gazette*, July 23rd, 1920).

To be temporary Captains: E. G. S. Hall, late Captain S.R., with seniority March 3rd, 1918; R. Stephens, late temporary Captain, with seniority October 15th, 1915.

Lieutenant J. P. P. Gallagher resigns his commission. The following officers relinquish their commissions; Temporary Major G. W. Beresford, and retains the rank of Major. Temporary Captain (acting Major) J. B. Butler, and is granted the rank of Major. Temporary Captains and retain the rank of Captain: I. Ridge Jones, Z. A. Green, E. G. M. Gilchrist, W. Kirk, H. H. McClelland. Temporary honorary Captain M. Bronk, and retains the honorary rank of Captain. Temporary Lieutenant J. A. B. Sim.

INDIAN MEDICAL SERVICE.

Major J. A. Cruickshank appointed temporarily to the staff of the Bombay Bacteriological Laboratory.

Lieut.-Colonel C. Milne and Brevet Colonel W. H. Ogilvie have been promoted to the rank of Colonel (May 19th and 20th, 1920, respectively).

Major E. H. B. Stanley has been promoted to the rank of Lieut.-Colonel (July 29th, 1920).

Lieut.-Colonel J. Entrican appointed to hold the office of the Inspector-General of Civil Hospitals, Burma, substantively *pro tempore*, with effect from April 21st, 1920, until further orders.

Major H. W. Pierpoint has been posted as Agency Surgeon, Baghelkhand.

Lieut.-Colonel S. Hunt has been appointed Residency Surgeon, Gwalior.

The following officers have been promoted to the rank of Major with effect from the dates specified—January 30th, 1921: B. Gale, J. H. Horne, H. H. King, R. E. Flowerdew, J. G. B. Shand, and A. J. Lee. January 31st, 1921: C. H. Smith, T. J. C. Evans, A. C. Anderson, D. G. Cooper, W. L. Forsyth, and G. T. Burke.

The undermentioned officers have been permitted to retire from the service: Lieut.-Colonel G. T. Birdwood (November 2nd, 1920), Lieut.-Colonel G. H. Frost (January 1st, 1921), Colonel P. J. Lumsden (November 27th, 1920).

Lieut.-Colonel S. Hunt, an Agency Surgeon on reversion from military duty, is posted temporarily as Agency Surgeon, Baghelkhand (December 31st, 1920).

Lieut.-Colonel R. Steen, M.B., has been transferred to the temporary non-selective list (December 7th, 1920).

TERRITORIAL FORCE.

ROYAL ARMY MEDICAL CORPS.

Captains to be Majors: E. T. H. Lea, J. L. Menzies, M.C. The following officers resign their commissions: Captains B. J. Alcock and L. D. B. Cogan, D.S.O., and are granted the rank of Major. Captain W. G. Cook, and retains the rank of Captain. Lieutenant H. G. Kilner, from 5th Battalion Suffolk Regiment, to be Captain with precedence as from September 8th, 1915.

TERRITORIAL FORCE RESERVE.

ROYAL ARMY MEDICAL CORPS.

The announcement regarding Captain L. A. Mackenzie, M.C., which appeared in the *London Gazette* of January 3rd, 1919, is cancelled.

SPECIAL RESERVE OF OFFICERS.

ROYAL ARMY MEDICAL CORPS.

Captain P. Walsh relinquishes the acting rank of Major. Captain E. T. H. Lea relinquishes his commission on appointment to the R.A.M.C.(T.F.). The following Captains relinquish their commissions and retain the rank of Captain: W. Buchan, V. D. Wyborn, D. Roger, E. S. Davies, A. J. Macartney, C. B. Dyson.

DIARY OF SOCIETIES AND LECTURES.

HARVEIAN SOCIETY OF LONDON, Town Hall, Paddington Green, W.—Thurs., 8.30 p.m., Dr. Leonard Williams: The Thyroid Gland in Everyday Life.

LONDON DERMATOLOGICAL SOCIETY, 49, Leicester Square, W.C.2.—Tues., 4.30 p.m., Cases; 5 p.m., Dr. R. Craik: Ringworms.

MEDICAL SOCIETY OF LONDON, 11, Chandos Street, W.1.—Mon., 8.30 p.m., Discussion on Non-operative Treatment of Surgical Tuberculosis, by Sir Henry Gauvain, followed by Sir Anthony Bowlby, K.C.B., P.R.C.S., Mr. T. H. Kellock, Dr. W. T. Gordon Pugh, and Mr. W. H. Trethowan.

MEDICO-LEGAL SOCIETY, 11, Chandos Street, W.1.—Thurs., 8.30 p.m., Sir John Collie: The Plaintiff—a Psychological Study.

MIDDLESEX HOSPITAL MEDICAL SCHOOL, W.—Fri., 3 p.m., Emeritus Lecture by Sir J. Kingston Fowler: Treatment of Tuberculosis.

ROYAL COLLEGE OF PHYSICIANS, Pall Mall East, S.W.—Thurs. and Thurs., 5 p.m.—Dr. A. Whitfield: Linnæan Lectures, Etiology of Skin Diseases.

ROYAL SOCIETY OF MEDICINE.—General Meeting of Fellows, Mon., 5.30 p.m.: Discussion on the Eradication of Tuberculosis in Men and Animals, to be opened by Sir John McFadyean, followed by Sir Clifford Allbutt, Dr. Arthur Leatham, Professor Hobday, Dr. A. C. Imbau, Mr. Cyril Nichol, Sir G. Sims Woodhead, and others.

General Meeting of Fellows, Tues. 5 p.m.: Ballot for election to Fellowship. *War Section*: Mon., 5.30 p.m., Colonel H. E. R. James: Instruction for Medical Students in case of National Emergency. *Section of Therapeutics and Pharmacology*: Tues., 4.30 p.m., Mr. P. B. Roth: Uses of Heliotherapy. *Section of Pathology*: Tues., 8.30 p.m., Sir Lenthal Cheate: Parenchymatous Inflammation of the Breast; Dr. J. A. Murray and Dr. W. H. Woglom: Experimental Tar Cancer; Dr. A. J. Eagleton: Standardization of Antipneumococcal Serum; Dr. Nathan Raw: Attenuated Tubercle Bacilli. *Section of History of Medicine*: Wed., 5 p.m., Professor G. Elliot Smith: Ancient Egyptian Pathology and Medicine; Mr. Geoffrey Keynes: Unpublished Letters of Sir Thomas Browne; Mr. Marshall Montgomery: Identity of "cursed hebenon" in *Hamlet* with *ignum vitæ*. *Section of Study of Disease in Children*: Wed., 8.30 p.m., Adjourned Discussion on Congenital Syphilis, to be reopened by Dr. Morley Fletcher, and continued by Mr. John Adams, Dr. Jewesbury, Mr. McDonagh, Mr. Neame, Dr. Pitts, and others. *Section of Dermatology*: Thurs., 4.30 p.m., Cases; 5 p.m., Mr. T. C. Benliss: Catalytic Enzymes as an Aid to Diagnosis of Hair Infections. Cases. *Section of Otolaryngology*: Fri., 5 p.m., Demonstration of pathological specimens by Dr. Albert Gray; Mr. Jefferson Faulder and Mr. Colledge: Ears under Modern War Conditions. Cases. *Section of Electro-Therapeutics*: Fri., 8.30 p.m., Mackenzie-Davidson Memorial Lecture (Professor W. D. Halliburton): Physiological Advance—the Importance of the Infinitely Little.

ROYAL SOCIETY OF TROPICAL MEDICINE AND HYGIENE, Royal Army Medical College, Grosvenor Road, S.W.1.—Fri., 8.15 p.m., Demonstrations.

POST-GRADUATE COURSES AND LECTURES.

GLASGOW POST-GRADUATE MEDICAL ASSOCIATION, Royal Maternity and Women's Hospital.—Wed., 4.15 p.m., Dr. S. J. Cameron: Obstetrical Cases.

HOSPITAL FOR SICK CHILDREN, Great Ormond Street, W.C.1.—Thurs., 4 p.m., Dr. Hutchison: Diseases of the Liver.

LONDON HOSPITAL MEDICAL COLLEGE.—Lecture Demonstrations on Gonorrhoea, Tues. and Thurs., 4.30 p.m., Mr. Clarkson: Men, Wed. and Fri., 4.30 p.m., Dr. Simpson: Women.

MANCHESTER ROYAL INFIRMARY.—Tues., 4.30 p.m., Mr. H. H. Rayer: Surgical Disorders of Infancy and Early Childhood.

NATIONAL HOSPITAL FOR DISEASES OF THE HEART, Westmoreland Street, W.1.—Mon., 5.30 p.m., Dr. S. Oodall: Practical Points in Treatment.

NATIONAL HOSPITAL FOR THE PARALYSED AND EPILEPTIC, Queen Square, W.C.1.—Daily (except Wed. and Sat.), 2 p.m., Out-patient Clinics. Lectures, 3.30 p.m.—Mon., Dr. Saunders: Friedreich's

Ataxia; Tues., Dr. R. Russell: Syphilis of the Nervous System; Thurs., Dr. Saunders: Occupation Neuroses; Fri., Dr. Hinds-Howell: Disseminated Sclerosis.

NORTH OF ENGLAND BRANCH, BRITISH MEDICAL ASSOCIATION, Mental Hospital, Ryhope.—Fri., 3 p.m., Professor J. Middlemiss: Incipient Insanity.

WEST LONDON POST-GRADUATE COLLEGE, Hammersmith, W.—Daily, 10 a.m., Ward Visits; 2 p.m., In- and Out-patient Clinics and Operations. Lectures, 5 p.m.—Mon., Dr. G. Stewart: Syringomyelia; Tues., Dr. Pernef: Acquired Syphilis in Infancy and Childhood; Wed., Mr. Gibb: Glaucoma; Thurs., Dr. B. Ball: Nasal Spurrage; Fri., Mr. Steadman: Dental Sepsis; Sat. (noon), Mr. Sinclair: Surgical Diseases of the Abdomen.

British Medical Association.

OFFICES AND LIBRARY, 429, STRAND, LONDON, W.C.2.

Reference and Lending Library.

THE READING ROOM, in which books of reference, periodicals, and standard works can be consulted, is open to members from 10 a.m. to 6.30 p.m., Saturdays 10 to 2.

LENDING LIBRARY: Members are entitled to borrow books, including current medical works; they will be forwarded, if desired, on application to the Librarian, accompanied by ls. for each volume for postage and packing.

Departments.

SUBSCRIPTIONS AND ADVERTISEMENTS (Financial Secretary and Business Manager, Telegrams: Articulate, Westrand, London), MEDICAL SECRETARY (Telegrams: Medisecra, Westrand, London), EDITOR, *British Medical Journal* (Telegrams: Altiology, Westrand, London). Telephone number for all Departments: Gerrard 2630 (3 lines).

SCOTTISH MEDICAL SECRETARY: 6, Rutland Square, Edinburgh, (Telegrams: Associate, Edinburgh. Tel.: 4361 Central.)

IRISH MEDICAL SECRETARY: 16, South Frederick Street, Dublin. (Telegrams: Bacillus, Dublin. Tel.: 4737 Dublin.)

Diary of the Association.

MARCH.

- 11 Fri. London: Standing Subcommittee of Central Ethical Committee, 2 p.m.
- 15 Tues. London: Propaganda Subcommittee, 2.15 p.m. Willesden Division: St. Andrew's Parish Hall, High Road, Willesden Green, N.W., 8.30 p.m.
- 16 Wed. London: Joint Conference of Ministry of Health, Medical-Political, Hospitals, and Public Health Committees, 2 p.m. Marylebone Division: 11, Chandos Street, W., 8.30 p.m.
- 18 Fri. London: Medico-Sociological Committee, 2 p.m. North of England Branch, Mental Hospital, Ryhope, 3 p.m. Professor J. Middlemiss: Incipient Insanity.
- 22 Tues. London: Public Health Committee (provisional). London: Science Committee, 2.30 p.m.
- 23 Wed. London: Hospitals Committee, 2.30 p.m.
- 24 Thurs. London: Rural Practitioners Subcommittee, 2.30 p.m.
- 30 Wed. London: Medico-Political Committee (provisional).

APRIL.

- 7 Thurs. Worcestershire and Herefordshire Branch: British Medical Association Lecture by Mr. P. L. Daniel, F.R.C.S., on the Differential Diagnosis of Acute Abdominal Conditions.

APPOINTMENTS.

ALEXANDER, R. C., M.A., M.B., Ch.B., F.R.C.S. Edin., Visiting Surgeon, Dundee Royal Infirmary.

DENNINO, F. A. V., L.R.C.P. and S. Edin., District Medical Officer and Public Vaccinator for the Rochester District of the Medway Union.

IVENS, Miss Frances, M.B., M.S. Lond., Honorary Surgeon to the Liverpool Maternity Hospital, vice Dr. Alexander Stookes, retired.

GERRARD, Miss D., M.B., Ch.B. Edin., Junior House-Surgeon at the Children's Hospital, Sunderland.

GLASS, A. G., M.A., M.D., D.P.H., Medical Officer of Health for the Combined Urban District of Farnworth and Kearsley, Lancs.

RIVETT, Louis Carnac, M.A., M.Ch. Cantab., F.R.O.S. Eng., Obstetric Surgeon to Out-patients at Queen Charlotte's Lying-in Hospital, Marylebone Road, N.W.

TANNER, W. E., M.S., F.R.C.S., Surgeon to Out-patients, the Evelina Hospital for Children, Southwark.

BIRTHS, MARRIAGES, AND DEATHS.

The charge for inserting announcements of Births, Marriages, and Deaths is 9s., which sum should be forwarded with the notice not later than the first post on Tuesday morning, in order to ensure insertion in the current issue.

DEATHS.

BROWNE.—On February 28th, 1921, at Lismore, Windsor Avenue, Belfast, Matilda Elwin, the beloved wife of J. Walton Browne, M.D.

WRIGHT.—On February 18th, at 7, Warwick Avenue, Paddington, Dr. Edward Wright, O.B.E., in his 54th year.

BRITISH MEDICAL JOURNAL. ⁷⁷

LONDON: SATURDAY, MARCH 19TH, 1921.

CONTENTS.

BRITISH MEDICAL ASSOCIATION.		PAGE	GENERAL MEDICAL COUNCIL:		PAGE
CURRENT NOTES:			MEETING OF THE EXECUTIVE COMMITTEE...		
INFLATION OF INSURANCE INDEX REGISTERS	77	INSURANCE CORRESPONDENCE:	...	79
A CLASSIFIED DIRECTORY	77	REGIONAL MEDICAL OFFICERS	80
FEES OF ADMIRALTY SURGEONS AND AGENTS	77	NAVAL AND MILITARY APPOINTMENTS	80
DANGEROUS DRUGS DRAFT REGULATIONS:			DIARY OF SOCIETIES AND LECTURES ...		
MEETING AT THE HOUSE OF COMMONS	77	ASSOCIATION INTELLIGENCE	80
ASSOCIATION NOTICES:			APPOINTMENTS...		
A ZANZIBAR BRANCH	79	BIRTHS, MARRIAGES, AND DEATHS	80
BRANCH AND DIVISION MEETINGS TO BE HELD	79			

British Medical Association.

CURRENT NOTES.

Inflation of Insurance Index Registers.

THE Insurance Acts Committee Executive and representatives of the Ministry of Health recently discussed the opinion which was expressed by the last Conference of Local Medical and Panel Committees—that inflation in the index registers is largely due to the dilatory methods of approved societies in returning the orange slips. The reply of the Ministry of Health has now been received, and is to the following effect:

It is recognized that it is of the utmost importance that approved societies should issue orange slips as soon as they are in possession of information as to persons ceasing to be entitled to medical benefit, and their attention has been called to this matter on several occasions. It will be remembered, however, that during the abnormal period of the war, and since the war, the difficulty which approved societies sometimes experience in getting information with regard to the position of their members has been seriously increased. It is hoped that the passing of this abnormal period and the coming into full operation of the new arrangements under which the medical benefit of persons going out of insurance is terminated at half-yearly periods, instead of, in all cases, at December 31st, will tend to eliminate the causes of former delays.

The Ministry will also be prepared to take action in regard to any particular cases which may be brought to their notice where there would appear to have been avoidable delay on the part of any society in issuing orange slips.

The Medical Secretary would be glad to hear of any particular instances of delay which have been brought to the notice of Panel Committees, in order that the matter may be taken up with the Ministry.

A Classified Directory.

In the JOURNAL of August 28th, 1920, p. 330, there appeared under the above heading a note drawing attention to a proposed publication, "The Buff Book," of which a circular had been issued by a firm styled the Business Telephone Directories Limited. The Central Ethical Committee of the British Medical Association considered that the insertion of a medical practitioner's name in this publication would be objectionable from the point of view that only selected names would be published therein to the exclusion of others. It seemed clear that no medical practitioner's name (with address and telephone number) would appear in "The Buff Book" unless he paid the minimum fee of one guinea. Further objection, moreover, arose in connexion with the specimens of type at varying prices shown in the circular. As will be seen from the report published in the SUPPLEMENT this week at p. 79, the Executive Committee of the General Medical Council has had this matter before it, and has passed a resolution which confirms, and indeed reinforces, the opinion expressed by the Central Ethical Committee of the British Medical Association. The grounds of objection, though stated in different words, are those put forward in the JOURNAL of August 28th last.

Fees of Admiralty Surgeons and Agents.

The British Medical Association has been endeavouring for the past twelve months to obtain a more reasonable

scale of fees for Admiralty surgeons and agents, but so far without any definite result. About June last a very satisfactory revised scale of fees was under the consideration of the Admiralty, but, unfortunately, it never received sanction. Frequent requests for an early settlement have always been met with the reply that the matter is under consideration by the Treasury. Feeling that the delay in this matter had been quite unreasonable, the Association requested Captain W. E. Elliot, M.P., to be good enough to ask a question in the House. Accordingly, Captain Elliot asked the Parliamentary Secretary to the Admiralty the following question:

When it is intended to revise the scale of fees paid by the Admiralty to surgeons and agents (Article 21, Clause 3), seeing that these fees are below those paid by other departments and have not been revised for thirty-five years, notwithstanding the enormous increase in the cost of living?

and received a reply as follows:

A revised scale of fees is now under consideration, and it is hoped that a decision may be reached and promulgated very shortly.

The reply is unsatisfactory, but it is hoped that the effect of the question will be to accelerate a decision.

DANGEROUS DRUGS DRAFT REGULATIONS.

MEETING AT THE HOUSE OF COMMONS.

ONE of the largest meetings of private members ever held at the House of Commons took place on Wednesday, March 9th, when some 200 members of Parliament gathered to hear the opinions of the medical and allied professions on the draft Regulations made by the Home Secretary under the Dangerous Drugs Act, 1920. Sir Henry Craik, K.C.B., M.P., was called upon to preside, and those immediately supporting him were: Mr. E. B. Turner, Chairman of the Medico-Political Committee of the British Medical Association, and Dr. Alfred Cox, Medical Secretary; Sir William Glyn-Jones, Secretary, Pharmaceutical Society of Great Britain; Mr. A. V. Alexander, Secretary, Parliamentary Committee of the Co-operative Congress; Mr. J. E. Connor, President, Pharmaceutical Society of Ireland; Mr. Walter McNab, Vice-Chairman, Scottish Pharmaceutical Federation; Mr. John Keall, President of the Retail Pharmacists' Union; Mr. Woolcock, M.P., and Mr. Kiley, M.P.

Sir HENRY CRAIK mentioned that there were some ten or twelve thousand members of the medical profession in the constituency (Scottish Universities) of which he was a representative, and he assumed that was why he was called to the chair. A large number of letters which members of Parliament had received indicated the immense amount of interest taken in this matter. He understood that they had met rather for inquiry than to protest against the proposed Regulations. Their object was to hear what well-known experts were able to tell them, in order that they might be prepared to criticize the Regulations when they came before the House of Commons. Since the meeting had been convened, Mr. Woolcock had received from Mr. Shortt, the Home Secretary, the following reply to a question:

"I have decided to appoint a small committee on the lines suggested by the hon. member, to consider and report to me in

cases in which we have not been able to come to an agreement with interested parties, what further modifications, if any, can safely and properly be made in the Draft Regulations, having regard to the main principles on which the Regulations are based, and which are essential in the public interest for safeguarding the use of drugs."

Sir WILLIAM GLYN-JONES expressed pleasure that so many members of the House of Commons were attending the meeting. The matter, he said, was of considerable importance, and it also involved a wider question, namely, what should be the procedure a department should take when the House delegated to it the working of legislation. This kind of thing was constantly arising. If as a result of the present difficulty, some procedure could be adopted whereby a Government department should take care to make such investigation as was necessary to put it in a fitting position to act for the House, still more good would result. Sir W. Glyn-Jones went on to present a statement of the position of affairs. He said that in January, 1912, Great Britain signed the Opium Convention which pledged the signatories to enact pharmacy laws or regulations to confine to medical or legitimate purposes the manufacture, sale, and use of morphine, cocaine, and their salts. The significant words were added: "unless laws or regulations on the subject are already in existence." Amongst the measures which the signatories were committed to take were: "To require that such persons shall enter in their books the quantities manufactured, imports, sales, and all other distribution, and exports of morphine, cocaine, and their respective salts." Again the following significant words are added: "This rule shall not necessarily apply to medical prescriptions, and to sales by duly authorized chemists." The Dangerous Drugs Act was passed last year to give the Home Office the power to make the required regulations. The Pharmaceutical Society being the statutory body to enforce the Pharmacy Acts in Great Britain, and to make regulations as to the keeping, dispensing, and selling of poisons, subject to the consent of the Privy Council, was also empowered by the Act to amend the schedule of poisons by adding thereto or removing therefrom any article, or by transferring an article from one part to another part of the schedule. The Council took the necessary steps to transfer from Part 2 of the schedule to Part 1 all the substances included in the provisions of the Dangerous Drugs Act, and the consent of the Privy Council to this change was notified in the *Gazette* on December 3rd, 1920.

On November 2nd the Home Office submitted for the confidential information of the Society and for the observations of its council a preliminary draft of the Regulations. On December 6th the Society wrote raising fundamental objections to the Regulations as drafted. The letter stated that the Society's council had appointed a subcommittee to place before the Home Office their suggestions, but wished to know at the first stage the opinion of the Home Secretary on the points raised in their communication. After a month's interval a reply was received from the Home Office disputing the preliminary objection, and saying that the Regulations were now formally issued in draft, and that any representations on details would be considered before the Regulations were finally made. The official notice had, in fact, been gazetted on January 7th and the draft Regulations published. They were ill-conceived and badly drafted, and bore on their face convincing evidence that the Home Office was without the knowledge of the conditions surrounding the supply of the substances dealt with, or that the Regulations were prepared with the deliberate disregard of those conditions. Nevertheless Sir Edward Troup wrote to the *Times* on February 10th a letter in which he said:

"The Regulations have not, as has been suggested, been issued without previous consultation with the interests most directly concerned. A preliminary draft was submitted to the Pharmaceutical Societies of Great Britain and Ireland, the General Medical Council, the Royal College of Physicians, and the Royal College of Surgeons."

To describe that statement as disingenuous would not be an extreme criticism. On February 3rd the Society submitted criticisms in detail, and asked that a joint deputation representing medical practitioners, pharmacists, dentists, veterinary surgeons, agriculturists, and other users of the drugs, should be received by the Home Secretary, with a view to urging the appointment by him of a joint committee to advise on the redrafting of the Regulations. The Home Office declined to receive the joint deputation, but offered to see one from the pharmacists. In the meantime officials of the Home Office were meeting various people separately and privately. On February 22nd a joint request, signed

by all the bodies represented and others, was sent asking for a re-consideration of the refusal to receive a joint deputation, with a view to the appointment of a small expert committee. On February 25th the Home Office replied maintaining its refusal.

Sir W. Glyn-Jones went on to say that the bodies concerned could not accept as a reasonable explanation of the alarmingly unsuitable character of the draft Regulations that they were put up to be shot at; but for the intervention of the societies referred to, the Regulations as drafted would have been made operative in due course. The societies realized that members of Parliament shared with their constituents a growing dislike of legislation by regulations and orders. Nothing but the most powerful reasons could justify the House of Commons deputing to a Government department the duty of legislating. It would have been inconvenient, if not impossible, for the House of Commons to have embodied such detailed provision in an Act of Parliament itself; if such an attempt had been made, the course would probably have been of appointing a Select Committee to take evidence, and upon its report the provisions would have been drafted. The duty, however, was delegated to the Home Office, in the belief that it would take adequate steps to see that the Regulations were properly made.

So much for the facts. He (Sir W. Glyn-Jones) was satisfied that the bulwark against the misuse of these drugs was the existence of people properly trained in responsibility. They could never by means of regulations prevent confirmed morphine takers from obtaining this drug. He hoped that the Select Committee to be set up would allow any person who had anything to tell them to come before them.

Dr. ALFRED COX said that that gathering was an inspiring sight for people who still believed in the power and the willingness of members of Parliament to protect the interests of the public. They were asking for the help of members to prevent the perpetration of a gross official blunder. When the body which he represented went to the Home Office, they received the greatest courtesy and consideration, and they were promised modifications which would go very far towards meeting the requirements of the profession. But they were not satisfied because they did not think that the method adopted was the proper one for dealing with these subjects. They had come to the House of Commons because they desired that this sort of thing should never happen again, and that next time a Government department was framing regulations to carry out an Act passed by the House of Commons, it should take care to consult people who knew what the business was. The Home Office said they did consult the people who knew. They went to the Royal College of Physicians, the Royal College of Surgeons, and the General Medical Council. To go to the Royal Colleges on matters of this kind was like going to the Lord Chancellor for advice on the habits of country solicitors. If they had come to the British Medical Association, which acted for the working members of the profession, that body would have advised them not to attempt to issue regulations which showed complete ignorance of ordinary practice and of human nature. Dr. Cox's second point was that the Committee which advised the Home Secretary should hear what each party had to say in the presence of the others. In this way the doctors would learn what the pharmacist considered were the objections to the Regulations; also what the wholesale men thought of them. To use a theatrical phrase, the Committee might be able to get the Home Secretary "to join the flats" and see that the Regulations were sensible and practical.

In the course of discussion, Sir William Glyn-Jones stated, with regard to the operation of the Regulations, that they had, after being framed, to be laid on the table of each House of Parliament for twenty-one days.

In reply to a question by Sir CLEMENT KINLOCH-COOKE as to the objection to the disclosure of certain drugs used in medicines prescribed, Dr. COX said that the Home Office intended to remedy this, but it had not been remedied yet.

Dr. MURRAY said that on a second reading of the bill he raised the question as to consultation by the Home Office with the Pharmaceutical Society and the British Medical Association, and understood that this was to be done.

Colonel RAW proposed:

That this meeting agrees to take all possible steps to secure the fullest consultation and consideration before the Dangerous Drugs Act Regulations are framed, and that a small committee take charge of the matter and report.

Mr. A. M. SAMUEL seconded the motion.

After further discussion the CHAIRMAN suggested that the following words should be added to the resolution:

In the opinion of this meeting any committee appointed by the Home Secretary should have wide terms of reference, and should be empowered to hear any evidence submitted to them on any matter affected by the Regulations, and should be sufficiently large to be fully representative.

The resolution thus developed was put to the meeting and carried unanimously.

The following were appointed members of the committee of representatives of the meeting:

Sir Henry Craik, Sir John Butcher, Sir Richard Winfrey, Lieut.-Colonel Raw, the Hon. W. Ormsby Gore, Mr. W. J. U. Woolcock, Dr. Murray, Mr. J. Hinds, Mr. Kiley, and Mr. A. E. Waterson.

On the motion of Mr. E. B. TURNER, seconded by Mr. E. T. NETHERCOAT, President of the Pharmaceutical Society, a hearty vote of thanks was passed to Sir Henry Craik for presiding.

Home Office Committee.

The Home Secretary has now appointed a Committee to consider the outstanding objections to the draft Regulations under the Dangerous Drugs Act, and to advise what modifications can safely and properly be made, having regard to the main principles on which the Regulations are based and which are essential in the public interest for safeguarding the use of the drugs.

The Committee is constituted as follows:

Mr. CHESTER JONES (Chairman),
Sir MALCOLM DELEVINGT, K.C.B.,
Captain W. E. ELLIOT, M.C., M.B., M.P.,
Major A. C. FARQUHARSON, M.D., M.P.,
Mr. GERALD A. FRANCIS, M.P.,
Mr. W. J. U. WOOLCOCK, C.B.E., M.P.

The secretary of the Committee is Mr. A. H. ANDERSON of the Home Office.

Association Notices.

A ZANZIBAR BRANCH.

THE following change has been made in accordance with the Articles and By-laws, and takes effect as from the date of publication of this notice:

That a Zanzibar Branch of the Association be formed, of area coterminous with the Protectorate of Zanzibar.

Representation in Representative Body. Under arrangements made by the Council, the Branch will be entitled to independent representation in the Representative Body, 1921-22, to return one Representative.

BRANCH AND DIVISION MEETINGS TO BE HELD.

SOUTH-WESTERN BRANCH.—An intermediate meeting of the Branch will be held at Newton Abbot on Thursday, April 7th. Members should notify the Honorary Secretary, Mr. F. A. Roper (12, Southernhay West, Exeter) not later than March 25th of any cases, notes, paper, specimens, or notices of motion they may wish to bring forward in order that they may be placed on the agenda paper.

GENERAL MEDICAL COUNCIL.

EXECUTIVE COMMITTEE.

A MEETING of the Executive Committee of the General Medical Council was held on February 21st, with Sir DONALD MACALISTER, President of the Council, in the chair.

Cessation of Reciprocity with Belgium.

A communication was received from the Privy Council, dated December 21st, 1920, stating that whereas the Kingdom of Belgium no longer afforded to the medical practitioners of the United Kingdom such privileges of practising in Belgium as were offered during the late war, the Order in Council of January 7th, 1915, should be revoked. The Executive Committee resolved, therefore, to instruct the Registrar that its resolution of January 22nd, 1915—that medical practitioners legally authorized to practise medicine, surgery, and midwifery in Belgium should be entitled to be registered in the Foreign List of the *Medical Register*—ceased to have effect as from December 21st, 1920, and that he should no longer register medical practitioners in the Foreign List in respect of Belgian qualifications.

Suggested Reciprocity with Spain.

A communication was received from the Privy Council including a translation of a Royal decree relating to the practice of medicine and dentistry in Spain with a view to

applying to Spain the provisions of Part II of the Medical Act of 1886. The decree stated that henceforth only doctors and dentists who had obtained their qualifications in countries with which Spain had reciprocal relations would be authorized to practise, and that temporary authorizations now in force would terminate as soon as the period expired for which they were granted. The Executive Committee represented that inquiries should be made by the Privy Council through the Foreign Office regarding: (1) the privileges of practising in Spain which would be afforded to registered medical practitioners of the United Kingdom in the event of reciprocity being established with that country, and also (2) the conditions and course of study and examinations prescribed for the attainment by Spanish practitioners of a medical diploma or degree entitling them to practise medicine, surgery, and midwifery in Spain, the recognition of which by the General Medical Council would be necessary in the event of reciprocity being established.

Ministry of Health and Post graduate Study.

THE REGISTRAR reported that a committee had been recently appointed by the Minister of Health to investigate the needs of medical practitioners and other graduates for further education in medicine in London, and to submit proposals for a practical scheme for meeting them. The Executive Committee expressed its gratification that the Ministry of Health had appointed such a committee, and desired that the scope of the investigations of the committee should be extended to the country as a whole. As, however, the statutory concern of the General Medical Council was not with post graduate instruction for registered practitioners but for the courses of study and examinations for primary qualifications, the Executive Committee felt itself unable to draw up any memorandum on the subject of post graduate instruction, but it was of opinion that many members of the Council would, if invited, be glad to submit their personal views for the information of the Ministry's committee.

Law Fellowship Book.

THE Executive Committee proceeded to deal with the question of the appearance of names in this book, which was informally under its consideration in November. The Bar Council had sent a communication stating that it considered that the book was issued for advertising purposes, and that it had resolved that it was not in accordance with the etiquette of the profession that barristers should insert their names in the book. The Law Society had so far felt a difficulty in expressing an opinion that it was contrary to the etiquette of the profession that solicitors should insert their names in the book. The view the Society had always expressed on the question of direct advertising was that so long as a directory was open to the whole profession without distinction, whether for payment or not, there was no objection to a solicitor allowing his name to appear in it; a further communication on the subject, however, might be sent. The Royal College of Veterinary Surgeons desired to be informed of any decision to which the General Medical Council might come on the subject. It was resolved:

That the Executive Committee is of opinion that the insertion of the name of a medical practitioner for payment, whether with or without typographical display, in a list issued to the public, and purporting to be a list of local medical practitioners, which is not open to the whole of the profession without such payment, is not in accordance with the professional standards in respect of advertising, and might be held to bring a practitioner so advertising himself within the terms of No. 5 of the Council's *Warning Notices*.

Correction of the Medical Register.

As a result of the issue of voting papers for the elections of direct representatives for the three divisions of the United Kingdom in November, 1919, 2,277 papers in all were returned through the Dead Letter Office. Although there is no obligation to do so, very great pains are always taken to prevent the unnecessary removal of names from the *Medical Register*, and in this case the usual care was taken. Not only were books of reference consulted, but information was obtained from the British Medical Association and other sources, and by the courtesy of the Editors a list of those who could not be traced was published in the *BRITISH MEDICAL JOURNAL* and *Lancet*. As a result only 484 names had to be erased from the *Register*, or in other words, 1,793 practitioners were saved from the serious consequences of their own neglect. In consequence of the close relationships which had been established between the Ministries of Health and Pensions, the Boards of Education and Trade, Insurance Committees,

chemists, and the General Medical Council, it is far more difficult now than it used to be for persons whose names do not appear upon the *Medical Register* to continue to practise as if registered.

INSURANCE.

CORRESPONDENCE.

Regional Medical Officers.

SIR.—A study of the Ministry of Health Memorandum N.M. 1 regarding regional medical staff will suggest the possibility of trouble in the working of the scheme. I would especially refer to the powers of the approved societies as detailed in paragraphs Nos. 11 and 24. In both, in the circumstances defined, the powers of the approved societies are absolute—that is, the desire or even the information of doctor or patient is ignored; the gravity of the matter is the more important in No. 24, where it is stated that the approved societies may draw the attention of the Regional Medical Staff when an insured member, admittedly incapable of work, has been in receipt of sickness or disablement benefit for at least four consecutive weeks, where they think it may be desirable that a second medical opinion should be obtained. The power of the societies to act is complete, and is in no way fettered or qualified by any feelings or wishes of patient or doctor.

This seems a new and unwarrantable interference between the patient and his medical attendant, and will surely constitute another obstructive snag to the easy progress of the National Insurance scheme. One can well imagine the possibility of onerous individuals in the societies doing irreparable damage between patient and doctor with such power in their hands, especially when prompted by personal grudges.

The Insurance Acts Committee might add to the many benefits which the practitioner and the community already owes to it by securing such amendment to this part of the scheme as will safeguard the legitimate interests of patient and doctor.—I am, etc.,

Llansantffraid, Mont., March 13th.

W. H. LEWIS.

Naval and Military Appointments.

ROYAL NAVAL MEDICAL SERVICE.

The following appointments are announced by the Admiralty: Surgeon Commanders J. M. Hayes to the *Castor*, G. Nunn, O.B.E., to the *Briton*. Surgeon Lieutenant Commanders H. H. Ormsby to the *Victory* for R.M. Division, Forton, H. Wilks to the *Thistle*, C. M. R. Thatcher to H.M. Dockyard, Portsmouth, R. F. P. Cory to the *Pembroke* additional, J. A. O'Flynn to the *Fitzroy*, G. F. B. Page to the *Beaufort*. Surgeon Lieutenants J. F. M. Campbell to the *Flinders*, J. H. B. Crosbie to the *Kellett*, J. J. Carroll to the *Burslem*.

ARMY MEDICAL SERVICE.

ROYAL ARMY MEDICAL CORPS.

Lieut.-Colonel M. P. Corkery, C.B.E., is placed on retired pay on account of ill health contracted on active service, February 5th, 1921 (substituted for the notification in the *London Gazette*, February 4th, 1921).

Major G. W. Heron, D.S.O., O.B.E., is seconded for service under the Foreign Office.

Captain and Brevet Major J. D. Kidd, O.B.E., M.C., relinquishes the acting rank of Major.

Temporary Captain J. H. Jones to be temporary Major whilst commanding troops on a hospital ship.

E. C. Lindsey, late temporary Captain, to be temporary Captain, with seniority from April 15th, 1916.

The notifications in the *London Gazette* of November 16th, 1916, and July 10th, 1919, regarding temporary Captain J. H. Jones are cancelled.

The following Lieutenants (temporary Captains) to be Captains: J. E. Measham, J. M. Savege, J. C. Burns, G. K. Fulton, R. B. Evans.

The following officers relinquish their commissions: Temporary Captain H. V. Lamb, and retains the rank of Captain; temporary Lieut. W. H. Steavenson, and retains the rank of Lieutenant.

SPECIAL RESERVE OF OFFICERS.

ROYAL ARMY MEDICAL CORPS.

Captain R. T. C. Robertson, D.S.O., to be Major.

The following officers relinquish their commissions: Captain, and is granted the rank of Major: H. D. Gardner. Captains, and retain the rank of Captain: F. M. Rorie, W. Andrew, H. Wands, F. Cameron, M.C.,

TERRITORIAL FORCE.

ROYAL ARMY MEDICAL CORPS.

Major F. Loud, T.D., Sussex R.G.A. (temporary Major R.A.M.C., T.F.) relinquishes his temporary commission in the R.A.M.C., T.F.

Captain J. R. Pooler, O.B.E., to be Major.

Captain H. B. Porteous relinquishes his commission in the Territorial Force on appointment to a permanent commission in the Royal Air Force.

To be Captains: Captains B. E. A. Ratt (late R.A.M.C.), with precedence as from April 14th, 1919; John Taylor (late R.A.M.C., S.R.), with precedence from April 1st, 1915; F. A. E. Crew (from 6th Battalion Devon Regiment), with precedence as from June 1st, 1916, and to remain attached to the Edinburgh University Officers' Training Corps; V. Townrow (late R.A.M.C.), with precedence as from February 10th, 1918.

To be Lieutenants: Captain L. H. Taylor (late R.A.M.C.), with precedence as from September 7th, 1916, and to relinquish the rank of Captain; Lieut. O. G. Misquith (late 24th Battalion London Regiment).

4th Northern General Hospital.—Major E. C. Clements, O.B.E., relinquishes his commission in the Territorial Force, August 1st, 1919, on appointment to a permanent commission in the Royal Air Force.

TERRITORIAL FORCE RESERVE.

ROYAL ARMY MEDICAL CORPS.

Major G. L. L. Lawson resigns his commission, July 15th, 1920, and is granted the rank of Lieutenant-Colonel (substituted for notification in the *London Gazette*, July 14th, 1920).

Captain C. H. J. Fagan, O.B.E., from General List to be Lieutenant-Colonel.

VOLUNTEER FORCE.

Surgeon-Captain R. W. Branthwaite (Surgeon-Captain Territorial Force Reserve), 2nd Cadet Battalion, London Regiment, resigns his commission on ceasing to be employed with a cadet battalion.

DIARY OF SOCIETIES AND LECTURES.

ROYAL SOCIETY OF MEDICINE.—*Section of Odontology*: Mon., 8 p.m., Mr. J. G. Turner: Dental Sepsis in Relation to Rheumatism, etc. *Section of Medicine*: Tues., 5.30 p.m., Dr. Parkes Weber: Thrombosis of Inferior Vena Cava and both Renal Veins. Dr. Nathan Raw: Treatment of Tuberculosis with Attenuated Tubercle Vaccines.

POST-GRADUATE COURSES AND LECTURES.

GLASGOW POST-GRADUATE MEDICAL ASSOCIATION, Royal Infirmary.—Wed., 4.15 p.m., Dr. D. Watson: Venereal Disease in the Male.

MANCHESTER ROYAL INFIRMARY.—Tues., 4.30 p.m., Dr. D. E. Core: Treatment of Neurasthenia.

NATIONAL HOSPITAL FOR DISEASES OF THE HEART, Westminster Street, W.1. Mon., 5.30 p.m., Dr. F. W. Price: Heart-block.

WEST LONDON POST-GRADUATE COLLEGE, Hammersmith, W.—Daily, 10 a.m., Ward Visits; 2 p.m., In- and Out-patient Clinics and Operations.

British Medical Association.

OFFICES AND LIBRARY, 429, STRAND, LONDON, W.C.2.

Reference and Lending Library.

THE READING ROOM, in which books of reference, periodicals, and standard works can be consulted, is open to members from 10 a.m. to 6.30 p.m., Saturdays 10 to 2.

LENDING LIBRARY: Members are entitled to borrow books, including current medical works; they will be forwarded, if desired, on application to the Librarian, accompanied by 1s. for each volume for postage and packing.

Departments.

SUBSCRIPTIONS AND ADVERTISEMENTS (Financial Secretary and Business Manager, Telegrams: Articulate, Westrand, London). MEDICAL SECRETARY (Telegrams: Medicisera, Westrand, London). EDITOR, *British Medical Journal* (Telegrams: Aitiology, Westrand, London).

Telephone number for all Departments: Gerrard 2650 (3 lines).

SCOTTISH MEDICAL SECRETARY: 6, Rutland Square, Edinburgh (Telegrams: Associate, Edinburgh. Tel.: 4361 Central.)

IRISH MEDICAL SECRETARY: 16, South Frederick Street, Dublin (Telegrams: Bacillus, Dublin. Tel.: 4737 Dublin.)

Diary of the Association.

MARCH.

- 22 Tues. London: Public Health Committee, 3 p.m.
London: Science Committee, 2.30 p.m.
London: Scrutiny Subcommittee, 11.30 a.m.
23 Wed. London: Hospitals Committee, 2.30 p.m.
24 Thurs. London: Rural Practitioners Subcommittee, 2.30 p.m.
30 Wed. London: Medico-Political Committee (provisional).

APRIL.

- 7 Thurs. Worcestershire and Herefordshire Branch: British Medical Association Lecture by Mr. P. L. Dantel F.R.C.S., on the Differential Diagnosis of Acute Abdominal Conditions.
South-Western Branch, Newton Abbot.

APPOINTMENTS.

HIRSCH, Charles T. W., M.R.C.S., L.R.C.P., Anaesthetist to Hospital for Epilepsy and Paralysis, Maida Vale.

JOHNSTON, W. H., M.D., F.R.C.S. (Edin.), Medical Superintendent to the Highbury, Uffculme, and Sorrento Hospitals, of the Birmingham Orthopaedic Centre, vice Dr. J. A. Dickson, resigned.

BIRTHS, MARRIAGES, AND DEATHS.

The charge for inserting announcements of Births, Marriages, and Deaths is 9s, which sum should be forwarded with the notice not later than the first post on Tuesday morning, in order to ensure insertion in the current issue.

BIRTHS.

ABRAHAM.—On March 4th, at 59, Cambridge Terrace, W.2, Lilian Angela (*née* Francis), wife of J. Johnston Abraham, C.B.E., D.S.O., F.R.C.S., of a daughter (Joan Lilian).

BEVAN-JOHN.—On March 11th, at "Fairfield," Llanelly, to Dr. and Mrs. R. Bevan-John, a son.

LONDON: SATURDAY, MARCH 26TH, 1921.

CONTENTS.

BRITISH MEDICAL ASSOCIATION.		PAGE	MEETINGS OF BRANCHES AND DIVISIONS		PAGE
CURRENT NOTES:			INSURANCE:		
PAY OF THE R.A.M.C.	81	CHARGES OF FRAUD IN INSURANCE PRACTICE	83		
REFUSAL OF A MEDICAL CERTIFICATE ON BEHALF OF A JURY-WOMAN	81	CORRESPONDENCE	84		
WELLHOUSE HOSPITAL, BARNET	81	NAVAL AND MILITARY APPOINTMENTS	84		
DANGEROUS DRUGS REGULATIONS:			DIARY OF SOCIETIES AND LECTURES	84	
SUMMARY OF EVIDENCE ON BEHALF OF THE ASSOCIATION BEFORE THE HOME OFFICE COMMITTEE	82	ASSOCIATION INTELLIGENCE	84		
ASSOCIATION NOTICES:			APPOINTMENTS... ..	84	
ELECTION OF COUNCIL AND REPRESENTATIVE BODY, 1921-22	82	BIRTHS, MARRIAGES, AND DEATHS	84		
MOTIONS FOR ANNUAL REPRESENTATIVE MEETING, 1921	83				

British Medical Association.

CURRENT NOTES.

Pay of the R.A.M.C.

THE Naval and Military Committee of the British Medical Association has had under consideration the question of pay and retired pay in the Royal Army Medical Corps. The revised scale of pay, published on September 13th, 1919, was not entirely satisfactory. The most notable anomaly which it contained was that concerning the retired pay of majors, who under the new scale actually received less money than they did before. The Association at once called attention to this point, and it has been remedied. The Committee is of opinion that the amended scale of pay and retired pay which was issued on October 9th, 1920, and published in the BRITISH MEDICAL JOURNAL, October 16th, is a fair scale, and compares favourably with those of other services. There are, however, several points which need adjustment, such as the absence of any provision for an increase in the pay of majors between fifteen years' service and the date of their promotion to lieutenant-colonel. There is also the case of the Director-General, A.M.S., who receives considerably less emoluments than any other officer holding a lieutenant-general's appointment, and, being on consolidated pay, is at a further disadvantage by reason of income tax. These matters will receive the attention of the Naval and Military Committee.

Refusal of a Medical Certificate on Behalf of a Jurywoman.

Recently the Under Sheriff of Middlesex declined to accept a certificate which stated that a certain lady on account of a recent operation for appendicitis was unable to serve upon a jury at the Middlesex Assizes. A certificate was sent in accordance with a notice on the summons which stated that

"Application for exemption from attendances at jury ... must reach the Summoning Officer within three days of the receipt of this summons supported by medical certificate or otherwise that you are or will be unable to serve."

The Under Sheriff wrote stating that he was unable to excuse the patient, and must ask her to attend. Not having attended she was afterwards informed that she had been fined £2 2s. for non-attendance. The medical practitioner asked for the advice of the British Medical Association, and was told that if the patient was prepared to fight the case out she ought to write to the authorities and tell them that she did not intend to pay the fine and would be prepared to take the consequences, when the doctor would be able to attend the court and state his views on the injustice of the whole procedure. The practitioner was strongly advised to press this case as a test case, and was offered any help the Association could give him. He has since reported that the patient adopted the suggestion

made to her, and received, first, an apologetic explanation suggesting that someone had exceeded his authority, and, later, a notice that the fine had been remitted.

Wellhouse Hospital, Barnet.

The Wellhouse Hospital, Barnet, is a Poor Law infirmary with 204 beds, under the control of the board of guardians of the Barnet Union. The British Medical Association has had brought to its notice arrangements which have been made by the Barnet guardians whereby separate accommodation will be provided in the Wellhouse Hospital for persons who cannot secure admission to the voluntary hospitals, and are able to pay for medical care, treatment, and nursing. The local medical profession, which had not been consulted at all in the matter, held a meeting on January 19th, when a resolution was passed maintaining that the practitioners in the Barnet rural area should be allowed the right of entry into the Wellhouse Hospital to attend their own patients sent in by them. This was forwarded with a covering letter to the guardians, who, however, replied that they were unable at present to entertain any proposal to interfere with the existing arrangements, and indicating that the scheme in question had received the sanction of the Ministry of Health. The British Medical Association then approached the Ministry of Health in this matter, and the Deputy Medical Secretary, in the course of a letter, wrote as follows:

"Knowing how firmly the Minister believes in the advisability of consultation, both centrally and locally, in any new development of this kind, the Association is surprised at being informed that the new arrangements at the Wellhouse Hospital have received the sanction of the Minister of Health. Any new proposals for the medical service of the community are not likely to meet with much success if at the outset they are framed so as to excite hostility in the minds of the local medical profession, for, after all, the health services of this country cannot be satisfactory unless the hearty co-operation of the medical profession is assured. I should be glad to know, as soon as possible, whether or not the Minister has sanctioned the proposed arrangements at the Wellhouse Hospital, and whether or not he suggested that the local profession should be consulted before the scheme was finally settled. If the Minister has given his sanction I would most respectfully request that he suggests to the Barnet guardians the advisability of consulting the local profession before the schemes are actually put into operation."

The reply to this letter stated that the Ministry of Health had not been consulted in regard to the scheme of the board of guardians concerned. Inquiries have, however, been made, and the following letter has been addressed by the Ministry to the guardians of the Barnet Union:

"I am directed by the Minister of Health to state that he has been informed that the guardians of the Barnet Union have in contemplation a scheme for admitting persons other than sick poor to the Wellhouse Hospital. Such a scheme appears to the Minister to raise very important principles, medical and other, and he would be glad to receive as early as possible a full statement of the exact nature of the proposals, and what steps, if any, have been taken towards putting them into operation."

The matter is being considered by the Hospitals Committee of the Association at its meeting this week.

DANGEROUS DRUGS REGULATIONS.

THE following is a summary of the evidence given on March 22nd before the Home Office Committee on Dangerous Drugs Regulations, by Dr. J. W. Bone and Dr. Alfred Cox, on behalf of the British Medical Association:

1. The Association understands that the Committee is in possession of the correspondence which has passed between the Association and the Home Office in respect to the Draft Regulations. It is proposed, therefore, to take the detailed consideration of the Regulations up at the point where it was left by the letter from the Home Office of February 15th, on the assumption that the alterations in the Regulations promised by the Home Office will be made.

2. But before dealing with any details of the Regulations the Association desires to emphasize the statement made in the first paragraph of its Memorandum of February 3rd—namely, that it is "aware of the public danger arising from the improper use of the drugs . . . and recognizes that in consequence medical practitioners must submit to the imposition of certain restraints in prescribing, compounding, dispensing and administering these drugs, and of certain clerical duties in recording their transactions in them." The Association, speaking on behalf of a very considerable section of the medical profession, trusts that before placing on the profession such restraints and clerical duties the Committee will satisfy itself that they are necessary, will carry out the objects of the Opium Convention, and are not merely being imposed on doctors because it is felt that as regulations must be imposed on some distributors they must be imposed on all.

3. Clause 7 of the Dangerous Drugs Act, 1920, says that provision may be made for, *inter alia*, regulating the issue of prescriptions and the dispensing of the drugs by medical practitioners "for the purpose of preventing the improper use of the drugs." The Association earnestly hopes that the Committee will satisfy itself that improper use of the drugs can rightfully be laid to the charge of the medical profession. So far as the British Medical Association has been able to ascertain there is no evidence that the medical profession has had any part in the illicit traffic in these drugs. Unless the Committee is satisfied that there is such evidence, the Association would urge that it will not countenance the idea of placing restrictions on a body of professional men to whom the lives and health of the community are entrusted, and who, therefore, may be assumed to be trustworthy as regards handling powerful and dangerous drugs. Their time ought not to be taken up in keeping records of small dealings in drugs, unless it can be proved that these records are essential.

4. The Association has carefully examined the draft Regulations as amended in accordance with the Home Office letter of February 15th. It would appear that the idea originally underlying the draft Regulations was that every distributor of the drugs shall keep a balance sheet of his dealings in them; that is to say, that every doctor, for example, shall keep records which would enable anyone investigating them to ascertain how much of each of the drugs has come into the doctor's possession and what has become of them. The Association agrees that if this could be done the information thus obtained would enable a close check to be kept on the distribution of these drugs.

5. But this idea, which presumably underlay the original draft Regulations, has been abandoned. The striking of a balance was never a possibility, even under the original draft. If Clauses 4 and 5 (as explained in the Home Office letter of February 15th) were not meant to apply to personal administration, and seeing also that no record need be kept of those quantities of the drugs which are used in making preparations of less percentage strength than those mentioned in the Act. Under the Regulations as amended the check kept on the distribution of those of "the drugs" which get into the possession of a medical practitioner is worthless.

6. The following example is taken from the practice of one of the witnesses (Dr. Bone) who is a partner in a large practice in Luton which dispenses for all its private patients:

In 1919 there were 25 buying transactions in the scheduled drugs which, aggregated, would appear as follows:

Opium.				
Tinct. opii	2 lb. 8 oz.
Liq. opii sed.	8 oz.
Pulv. ipecac. co.	4 oz.
Pil. plumbi c. opio (gr. 5)	1 gross
Pil. opii (gr. 1/2)	1 gross
Morphine.				
Morph. sulph.	2 dr.
Liq. morph. hydrochlor.	9 oz.
Tinct. chlor. et morph.	6 oz.
Hypodermic tablets morph. sulph. (gr. 1/4)	2 tubes
(20 in each tube)				
Hypodermic tablets morph. sulph. (gr. 1/6)	2 tubes
(20 in each tube)				
Heroin.				
Tabellac heroin (gr. 1/25)	124
Cocaine.				
Tabell. cocain et pot. chlorat.	200
Ophthalmic tablets cocaine hydrochl. (gr. 1/50)	2 tubes
(12 in each tube)				

7. The *outgoings* that would require to be recorded under the Regulations (as amended by the Home Office letter of February

15th) would only be those relating to pulv. ipecac. co., pil. plumbi c. opio, pil. opii, and the tablets of heroin and cocaine, as these are the only transactions in which any of the drugs were dispensed at or above the scheduled percentage strength. In every other case the drugs were administered personally or were dispensed in mixtures below the scheduled strength. Such a record would, it appears to the Association, be useless as a check on illicit traffic.

8. The Association would again raise the question asked in its letter of February 3rd—namely: "In small hospitals without resident house-surgeons, in nursing homes and in private practice where a trained nurse is in attendance it is a common occurrence to leave a hypodermic injection or a sedative draught which would contain one of the scheduled drugs to be given if necessary. Would this be in conformity with the Regulations, or would the nurse or orderly be a person not authorized to be in possession of the drug?"

The class of cases above alluded to is a very common one, and unless the doctor can delegate his authority to administer the drugs personally there will be much totally unnecessary suffering. It cannot be expected, for example, that the honorary medical officers to hospitals should pay visits to those institutions merely to administer a sedative drug which up to the present has been administered, without any evidence of abuse, by trained nurses or other responsible persons.

9. The Association believes that Regulation 9 presents the following dilemma. Take the case of a person handing to a chemist, say in Brighton, a prescription purporting to be signed by a doctor in York. Either the chemist is a very careful person who declines to take the risk of deciding whether or not the prescription is really signed by a medical practitioner (he could only be sure if he were familiar with the writing), or he accepts the prescription at its face value and takes the risk of it being a forgery. In the first case the patient may be put to quite unnecessary inconvenience; in the second the Regulation is seriously impaired as a protection against unauthorized possession of the drugs.

10. Regulation 13. The Association is not satisfied with the answer given in the Home Office letter of February 15th. It is not yet clear whether Regulation 13 does or does not require that the messenger of an authorized person (either doctor, chemist, or patient) must be authorized in writing to receive the drugs. If it is meant that there is to be an authorization in writing in every case, the demand is an impossible one. If such authorization is not demanded, the uncertainties and difficulties of the pharmacist seem to be very great. Any undue difficulties placed in the way of the pharmacist will, of course, be reflected on the patient, and in due course on the doctor who gives the prescription.

11. The Association must in any case press for the exclusion of the substances mentioned in its letter of February 15th. Regulations may be necessary as regards some preparations of the drugs, but it is impossible for anyone to hold that any of the substances mentioned in that letter (with the possible exception of pulv. ipecac. co.) could be used by the illicit drug-taker. There seems no reason why they should not be excepted from any restrictions laid on prescriber, buyer or seller.

Association Notices.

ELECTION OF COUNCIL OF ASSOCIATION,
1921-22.

A LIST of the Groups of Branches in the United Kingdom for election of twenty-four Members of the Council, 1921-22, and **Nomination Form**, were published in the SUPPLEMENT of March 12th (p. 73). The **Nominations** must be in the hands of the Medical Secretary **by May 16th**.

The result of the election for Members of Council by the Groups of the Oversea Branches was published in the SUPPLEMENT of February 19th, 1921.

ELECTION OF REPRESENTATIVE BODY OF
ASSOCIATION, 1921-22.*Constituencies in Representative Body.*

THE Council has finally grouped the **Home Divisions** for election of the Representative Body, 1921-22, in the same manner as for 1920-21, except that the Caithness and Sutherland Division of the Northern Counties of Scotland Branch, and the Rotherham and Sheffield Divisions of the Yorkshire Branch, have been made independent Constituencies.

As intimated to all the **Overseas Bodies**, the Council has made each Oversea Division and Division-Branch an independent Constituency.

Election of Representatives and Deputy-Representatives.

THE REPRESENTATIVES AND DEPUTY-REPRESENTATIVES in the Representative Body must be elected not later than **June 17th**, and their names notified to the Medical Secretary **not later than June 24th**. The Annual Representative Meeting at Newcastle begins on July 15th.

Special attention is drawn to the fact that the election of Representative(s) and Deputy-Representative(s) may, at the discretion of the Constituency, be carried out by General Meeting of the Constituency, or by postal vote.

MOTIONS FOR ANNUAL REPRESENTATIVE MEETING, NEWCASTLE, JULY, 1921.

NOTICES OF MOTION by Divisions, Constituencies, or Branches, for the consideration of the Annual Representative Meeting of the Association, commencing Friday, July 15th, 1921, proposing to make any addition to, or any amendment, alteration, or repeal of, any Article or By-law, or to make any new Article or By-law, or proposing material alteration of the policy of the Association in matters relating to the honour and interests of the profession or of the Association, must be published in the *BRITISH MEDICAL JOURNAL SUPPLEMENT* not later than May 14th, and for this purpose should be received by the Medical Secretary **not later than April 30th.**

LIBRARY OF THE BRITISH MEDICAL ASSOCIATION.

A LIST of periodical publications, official reports, and Blue Books in the Library of the British Medical Association available for issue to members on loan has been printed, and copies can be obtained free on application to the Librarian at the house of the Association, 429, Strand, W.C. The regulations governing the loan of these publications are stated in the introduction to the list. The Library is open for consultation from 10 a.m. till 6.30 p.m. (on Saturdays 10 a.m. till 2 p.m.).

BRANCH AND DIVISION MEETINGS TO BE HELD.

SOUTH-WESTERN BRANCH.—An intermediate meeting of the Branch will be held at Newton Abbot on Thursday, April 7th. Members should notify the Honorary Secretary, Mr. F. A. Roper (12, Southernhay West, Exeter) not later than March 25th of any cases, notes, papers, specimens, or notices of motion they may wish to bring forward in order that they may be placed on the agenda paper.

Meetings of Branches and Divisions.

MALAYA BRANCH.

The Malaya Branch of the British Medical Association held a conference on January 20th, 1921, with the Commissioners of the National Council for Combating Venereal Diseases. Dr. MALCOLM WATSON, president of the Malayan Branch of the Association, presided, and in his opening address welcomed the advent of the Commissioners and dwelt on the importance of venereal disease to the community. Dr. HALLAM stated that the objects of the Commission were to confer with the local authorities in the Far Eastern ports with regard to the possible measures which might be undertaken to reduce the incidence of venereal disease, and spoke of the recommendations which had been approved by the National Council for the provision of free treatment, early treatment centres, and a campaign of education of the general public. He mentioned the fact that in Japan the public health department was in favour of suppressing brothels, and cited as an instance the improvement in one of the counties of Japan in which the measures had been already enforced.

Dr. D. J. GALLOWAY in his reply gave full approval to the establishment of free diagnosis and free treatment, and although approving of a campaign of education of the general public in principle, he was of opinion that little could be done on that score in Singapore. He proceeded to point out the great divergence which existed between the facts as existing there and the commonly accepted ideals which were held on this subject in civilized countries, and urged that the only way by which any useful measure could be evolved to deal with the evil was by a careful study of the local conditions. To that end he moved the following resolution:

That this Association memorialize the Government of the Straits Settlements and Federated Malay States to cause full enquiry to be made as to (a) the prevalence of venereal disease, (b) the cause of that prevalence, (c) means of treatment, (d) means of prevention, and (e) the subject of prostitution generally.

Dr. RATRAY, in seconding Dr. Galloway's proposal, stated that for the past year he had been making efforts to establish a kindred society in Malaya, giving greater prominence to the value of disinfectants in the prevention of venereal disease. Dr. HOOPS gave his experiences of the value of antiveneal clinics which he had established in Kedah. Dr. HACKER spoke of his experiences with the garrison in Singapore; he was in favour of early treatment.

In the subsequent discussion, Dr. CANDRIK, Dr. GLASS, Dr. DAWSON and Dr. VAN DORT joined. The proceedings were terminated by the unanimous adoption of Dr. Galloway's resolution, a copy of which has been forwarded to the Colonial Secretary. The Council and members of the Malaya Branch afterwards entertained the Commissioners to dinner at the Europe Hotel.

METROPOLITAN COUNTIES BRANCH: MARYLEBONE DIVISION.

A MEETING of the Marylebone Division was held on March 16th, when SIR JAMES GALLOWAY was in the chair. The senior honorary secretary, Mr. C. Edward Wallis, was welcomed back after his recent serious illness, and Messrs. E. E. Ware and Philip Figdor were elected to fill the vacancies on the Branch Council. Dr. T. WATTS EDIN gave a most interesting address on "Some notes on the treatment of private patients in hospitals in the United States of America and Canada," which was followed by a discussion.

MIDLAND BRANCH: NOTTINGHAM DIVISION.

THE report of the work done by the Division in 1920 shows that the membership increased from 161 to 177. During the year there were twelve Divisional meetings, four of which were combined meetings with the Nottingham Medico-Chirurgical Society, at which scientific and clinical matters only were discussed. The Executive Committee had nine meetings, while there were several smaller meetings, such as delegates meeting the Colliery Field Club Board four times and numerous smaller special meetings at various centres. In the early part of the year the Division agreed that all doctors should raise their private fees 50 per cent., and this was advertised to the public.

The Division, after a long and arduous fight with the Colliery Field Club, has just brought this dispute to a satisfactory ending. As a result of this the contract price for medical attendance on dependants of miners has been raised from 16s. 3d. to 21s. 8d. per annum per married man, in addition to the whole system being placed upon what the Executive hopes will prove to be a more satisfactory and businesslike footing. The result of these negotiations is that the salaries of the Notts colliery surgeons have been increased by £8,242 per annum, or an average of £114 10s. per colliery surgeon. Before 1916 the contract price for this was only 15s. 6d.

Again, owing to the action of the local Division, the salary for maternity and child welfare work in one district was raised from £20 to £80 for forty sessions. A scheme has already been started in some of the districts whereby neighbouring practitioners do one another's holiday work. It is hoped to develop this scheme further in the future. In addition to the above local work, the Executive Committee points out that during the year the increased capitation rates for attendance under the National Insurance Act came into force, and that the British Medical Association was largely responsible in obtaining that increase from the Government.

INSURANCE.

CHARGES OF FRAUD IN INSURANCE PRACTICE.

IN the JOURNAL of December 25th, 1920, at p. 932, we recorded that at the Manchester Assizes on November 29th Dr. J. T. Godfrey, of Royton, was convicted and sentenced to three months' imprisonment on an indictment charging him with fraudulent conversion of goods and attempting to obtain money by false pretences. The charges were preferred by the Lancashire Insurance Committee. We have now received from the Ministry of Health a communication relating to an inquiry held at Manchester on February 9th under Part VI of the Medical Benefit Regulations, 1920, in regard to Dr. J. T. Godfrey, together with the report of the Inquiry Committee, and a formal statement of the Minister's decision.

The Committee of Inquiry consisted of Mr. Hugh Gamon, barrister-at-law (chairman), Dr. A. Forbes, and Dr. T. A. Goodfellow. The Minister of Health was represented by Mr. L. G. Dawson, and Dr. Godfrey by Mr. John G. Mahaffy. The administrative officer and cashier of the Lancashire Insurance Committee gave evidence on oath as to the nature of the offences. It was admitted on the part of Dr. Godfrey that his conviction was on six charges, of which three related to attempts by him to obtain payment from the Lancashire Insurance Committee in respect of fictitious attendances upon insured persons, and the other three charges concerned the obtaining by Dr. Godfrey for his own benefit from a chemist of drugs and appliances by means of prescriptions written by him containing the names of insured persons from his list of patients. Dr. Godfrey, in the course of his evidence before the Committee, stated on oath that he had been unjustly convicted, contending that the evidence upon which his conviction had been obtained was to a large extent false, and suggesting that his conviction was the result of a conspiracy. He, however, brought before the Committee no evidence to support such contention, and the Committee was not able to accept his unsupported evidence of his innocence with regard to the transactions in question. They expressed themselves satisfied that all the offences, and particularly those of attempting to obtain money by false pretences, were deliberately committed.

The Minister of Health, having read and considered the Inquiry Committee's report, is satisfied that Dr. Godfrey's continuance on the Medical List would be prejudicial to the efficiency of the medical service of the insured, and accordingly decides that his name be removed as from April 1st, 1921, from the Medical Lists of the Insurance Committees for the County of Lancaster and for the County Boroughs of Oldham and Rochdale.

CORRESPONDENCE.

The New Medical Records.

SIR.—I am in practice in Scotland, in the County of Renfrew Insurance Area, and here is my experience with the new record cards and envelopes:

My record cards begin with the date January 7th, 1921, which was the date on which I received them.

On March 12th, 1921, my envelopes arrived and I proceeded to put the record cards inside. I found (1) I was duplicating on the envelope the date on the record card; (2) I must get hold of a paper cutter, or some such implement, in order to open up the inside of the "paper poke" and get the record card to reach the bottom; (3) I must double the size of my former cabinet to accommodate the envelopes and record cards, at what will no doubt be a substantial sum.

Meanwhile I have suspended operations pending an envelope opener and an enlarged cabinet.—I am, etc.,

THOS. CARRUTHERS, M.A., M.B., Ch.B.

Kilbarchan, Renfrewshire, March 17th.

The Dental Bill and Insurance Practice.

SIR.—Has any consideration been given as to how the new Dental Bill will affect panel practitioners? At the present time about nineteen-twentieths of insurance patients are treated by unqualified dentists.

I understand that under the present Regulations panel practitioners are liable to give anaesthetics for dental treatment. I presume that we shall now be compelled to attend at the surgeries of these formerly unqualified men which will cause a large increase of work. I hope I am wrong in my surmise. I shall be glad to know it.

It would be rather a Gilbertian situation if one week one is punished by the General Medical Council for giving an anaesthetic for a man, and the next week punished by the Insurance Commissioners for not doing so. Great is the power of parliamentary whitewash.—I am, etc.,

Worcester, March 20th.

W. G. BENNETT.

Naval and Military Appointments.

ROYAL NAVAL MEDICAL SERVICE.

The following appointments are announced by the Admiralty: Surgeon Commander K. H. Jones to the *Fisgard*. Surgeon Lieutenant H. A. L. Guthrie to the *Robin*.

ARMY MEDICAL SERVICE.
ROYAL ARMY MEDICAL CORPS.

Lieut.-Colonel E. A. Bourke, D.S.O., is placed on retired pay on account of ill health contracted on active service.

The following temporary Captains relinquish their commissions and retain the rank of Captain: J. Anastasia, M.B.E., A. G. Wright.

ROYAL AIR FORCE.
MEDICAL BRANCH.

The following are granted permanent commissions as Flight Lieutenants, retaining their present seniority (subject to acceptance of final conditions of service): the notification in the *London Gazette* of July 13th appointing these officers to short-service commissions is cancelled; E. N. H. Gray, R. E. Bell, E. A. Lumley, M.C., D. G. Boddie, H. McW. Daniel, A. E. Barr-Simm (July 13th, 1920).

Flight Lieutenant D. McLaren is granted a permanent commission, retaining his present substantive rank and seniority (subject to acceptance of final conditions of service, March 31st, 1920). The notification in the *London Gazette* of September 14th, 1920, appointing this officer to a short-service commission is cancelled.

TERRITORIAL FORCE.
ROYAL ARMY MEDICAL CORPS.

Lieut.-Colonel A. B. Lyon, T.D., is appointed to command 1st London C.C.S.

Lieut.-Colonel J. H. Harris, T.D., resigns his commission and retains the rank of Lieutenant-Colonel, with permission to wear the prescribed uniform.

Captain and Brevet Major R. E. Barnsley, M.C., R.A.M.C., to be Adjutant of the R.A.M.C. School of Instruction, Northern Division (T.F.).

Captain P. J. Gaffikin, M.C., to be Major.

The following officers resign their commissions:—Major J. R. Lensen, and is granted the rank of Lieutenant-Colonel. Major A. W. French, T.D., and retains the rank of Major. Captain W. T. P. Meade-King, and is granted the rank of Major. Captains, and retain the rank of Captain: C. F. Backhouse, A. J. H. Isles, S. L. Brimblecombe, C. E. M. Jones, C. H. Maskew, A. V. Maybury.

5th Southern General Hospital.—The following officers resign their commissions and retain their rank: Lieut.-Colonel J. L. Square, Major (brevet Lieut.-Colonel) J. W. Gill, Major A. C. Roper, Captain (brevet Major) E. G. Smith, and Captains W. L. Pethybridge, G. F. Clion, G. C. F. Robinson, B. Dyball, R. V. Solly, R. Jaques, H. Andrew, and C. D. Lodsey.

5th Southern General Hospital.—The following officers resign their

commissions and retain their rank: Major N. E. Aldridge, Captains C. H. Sanders, M. H. Way, J. L. Wright, C. Lamplough, J. E. F. Falser, A. W. Power.

TERRITORIAL FORCE RESERVE.

ROYAL ARMY MEDICAL CORPS.

Lieut.-Colonel C. A. Lees, C.B.E., from 2nd London (County of London) General Hospital, to be Lieutenant-Colonel.

DIARY OF SOCIETIES AND LECTURES.

ROYAL SOCIETY OF MEDICINE.—*Section of Laryngology*: Fri., 4 p.m., Cases. 4.15 p.m., Mr. A. Ryland: Epidiascope Demonstration of a Pharyngeal Pouch. *Section of Anaesthetics*: Fri., 8.30 p.m., Drs. R. L. Mackenzie Wallis and C. Langton Hewer: A New General Anaesthetic.

ST. JOHN'S HOSPITAL, 49, Leicester Square, W.C.—Thurs., 6 p.m., Chesterfield Lecture, Dr. W. Griffith: Bullous Eruptions.

POST-GRADUATE COURSES AND LECTURES.

GLASGOW POST-GRADUATE MEDICAL ASSOCIATION, Lock Hospital, 41, Tottenhamrow.—Wed., 4.15 p.m., Dr. Madeline Archibald: Venereal Disease in the Female.

WEST LONDON POST-GRADUATE COLLEGE, Hammersmith, W.—Daily, 10 a.m. (and 2.30 p.m. Fri.), Ward Visits; 2 p.m., In- and Out-patient Clinics and Operations.

British Medical Association.

OFFICES AND LIBRARY, 429, STRAND, LONDON, W.C.2.

Reference and Lending Library.

THE READING ROOM, in which books of reference, periodicals, and standard works can be consulted, is open to members from 10 a.m. to 6.30 p.m., Saturdays 10 to 2.

LENDING LIBRARY: Members are entitled to borrow books, including current medical works; they will be forwarded, if desired, on application to the Librarian, accompanied by Is. for each volume for postage and packing.

Departments.

SUBSCRIPTIONS AND ADVERTISEMENTS (Financial Secretary and Business Manager. Telegrams: Articulate, Westrand, London). MEDICAL SECRETARY (Telegrams: Mediseera, Westrand, London). EDITOR, *British Medical Journal* (Telegrams: Ailiology, Westrand, London). Telephone number for all Departments: Gerrard 2630 (3 lines).

SCOTTISH MEDICAL SECRETARY: 6, Rulland Square, Edinburgh. (Telegrams: Associate, Edinburgh. Tel.: 4361 Central.)

IRISH MEDICAL SECRETARY: 16, South Frederick Street, Dublin. (Telegrams: Bacillus, Dublin. Tel.: 4737 Dublin.)

Diary of the Association.

MARCH.

- 23 Tues. London: Grants Subcommittee, 10 a.m.
London: Organization Committee, 12 noon.
30 Wed. London: Medico-Political Committee, 2.30 p.m.

APRIL.

- 1 Fri. London: Central Ethical Committee, 2 p.m.
London: Medico-Sociological Committee, 2.30 p.m.
7 Thurs. Worcestershire and Herefordshire Branch: British Medical Association Lecture by Mr. P. L. Daniel, F.R.C.S., on the Differential Diagnosis of Acute Abdominal Conditions.
South-Western Branch, Newton Abbot.

APPOINTMENTS.

RICHARDS, H. A., M.A., B.Ch.Cantab., Junior Anaesthetist and Assistant Instructor in Anaesthetics to King's College Hospital.

ROBINSON, G. C. F., F.R.C.S. Eng., Honorary Consulting Surgeon to East Cornwall Hospital (Bodmin), Liskeard Cottage Hospital, Fowey Cottage Hospital, Kingsbridge Cottage Hospital, Totnes and District Hospital.

BIRTHS, MARRIAGES, AND DEATHS.

The charge for inserting announcements of Births, Marriages, and Deaths is 9s, which sum should be forwarded with the notice not later than the first post on Tuesday morning, in order to ensure insertion in the current issue.

MARRIAGES.

ANDERSON—HOOD.—On the 18th March, at St. Columba's (Church of Scotland), Pont Street, S.W., the marriage of Major H. Graeme Anderson, M.D., F.R.C.S., R.A.F., of 75, Harley Street, W., to Gladys, elder daughter of Charles Hood, of Hatch End, Middlesex.

JARVIS—COCKBURN.—At Duddingston Kirk, Midlothian, on March 17th, 1921, by the Rev. William Robertson, D.D., assisted by the Rev. William Serle, B.D., Captain Oswald D. Jarvis, O.B.E., Royal Army Medical Corps, to Alice, eldest daughter of the late Rev. George Cockburn, B.D., and of Mrs. Cockburn, 13, Elm Place, Aberdeen.

DEATHS.

FORT.—On March 13th, at Shorelea, Oldham, Lancs., Thomas Fort, M.R.C.S., L.R.C.P., L.M., in his 69th year.

KAY.—March 11th (suddenly), at The Grove, Starbeck, Harrogate, Elizabeth Mary, wife of Walter Smith-Kay, M.D., formerly Medical Superintendent of West Riding Asylum, Wadsley, Sheffield.

CONTENTS.

BRITISH MEDICAL ASSOCIATION.	PAGE
CURRENT NOTES:	
SECURITY OF TENURE FOR MEDICAL OFFICERS OF HEALTH ...	85
POST-GRADUATE EDUCATION ...	85
I.M.S. PAY—CIVIL SIDE ...	85
SECTIONS AT THE ANNUAL MEETING ...	85
MEDICAL BOOKS FOR SERBIA ...	85
MUNICIPAL CLINICS AND THE PRIVATE PRACTITIONER. CONFERENCE OF COMMITTEES OF THE ASSOCIATION	86
ASSOCIATION NOTICES:	
SCHOLARSHIPS AND GRANTS IN AID OF SCIENTIFIC RESEARCH	87
ELECTION OF COUNCIL AND REPRESENTATIVE BODY, 1921-22 ...	87
MOTIONS FOR ANNUAL REPRESENTATIVE MEETING, 1921 ...	87
MEETINGS OF BRANCHES AND DIVISIONS ...	88

	PAGE
THE FUTURE OF THE MEDICAL SERVICES IN CHESTER AND THE DISTRICT. BY JOHN ELLIOTT, O.B.E., M.D., F.R.C.P. ...	89
THE BRADFORD MUNICIPAL HOSPITAL. REPORT OF THE BRADFORD ADVISORY MEDICAL COMMITTEE ...	91
INSURANCE:	
CORRESPONDENCE ...	88
COUNTY OF LONDON PANEL COMMITTEE ...	89
NAVAL AND MILITARY APPOINTMENTS ...	92
DIARY OF SOCIETIES AND LECTURES ...	92
ASSOCIATION INTELLIGENCE ...	92
APPOINTMENTS... ...	92
BIRTHS, MARRIAGES, AND DEATHS ...	92

British Medical Association.

CURRENT NOTES.

Security of Tenure for Medical Officers of Health.

THE Public Health Committee of the Association at its meeting on March 22nd had under consideration the question of security of tenure of medical officers of health. Sanction had previously been obtained from the Council to proceed with the preparation of a bill with the object of obtaining security of tenure for medical officers of health and sanitary inspectors. This action had become necessary owing to Dr. Addison's statement in the House of Commons on March 2nd that legislation would be necessary to give security of tenure to existing health officers. The Committee has taken a bill called the Public Health Officers Bill, which was drawn up by the Association in 1910, and made such amendments to it as will give it the best possible chance of obtaining parliamentary sanction. Sir Philip Magnus, who has for many years been an enthusiastic supporter of the Association's efforts to obtain this object and who has given valuable assistance in the past, has again very kindly promised to undertake to introduce the bill, and it will now be pressed forward with all possible speed. He hopes it will be possible to gain for the bill the friendly interest of the Minister of Health. The Association has been advised that it would not only be futile but very inadvisable to make any effort at the present time to obtain superannuation for medical officers of health, and, in view of this advice and the statements on the subject which have recently been made in the House by Dr. Addison, has decided not to press this question for the present.

Post-Graduate Education.

The Science Committee of the British Medical Association has lately had under consideration the question of post graduate medical instruction in Great Britain, more particularly with a view to co-operation in the work of the Fellowship of Medicine and Post-Graduate Medical Association. In the meanwhile, as announced in the JOURNAL of January 29th, the Ministry of Health appointed a Committee, under the chairmanship of the Earl of Athlone, with the following terms of reference:

"To investigate the needs of medical practitioners and other graduates for further education in medicine in London, and to submit proposals for a practicable scheme for meeting them."

Upon the appointment of this Departmental Committee the British Medical Association requested to be allowed to submit evidence which it felt would prove of value to the Committee in its deliberations. The President of the Association, the Right Hon. Sir Clifford Allbutt, with Dr. C. O. Hawthorne and Mr. R. J. Willan, attended before the Committee on March 15th, and we hope to publish shortly a summary of their evidence.

I.M.S. Pay—Civil Side.

The British Medical Association has just been informed by the India Office that the revised rates of pay for the civil side of the Indian Medical Service which were promised in June, 1920, were announced in India on March 3rd, 1921. There has been a delay in issue of this pay which seems unreasonably long, and the Association has on several occasions lately informed the India Office that such delay was giving rise to very widespread dissatisfaction. The pay of administrative officers has not yet been decided upon, but it is understood that the proposals of the Government of India on this subject are now in the hands of the India Office, and the Association is pressing the India Office for an early decision on this matter.

Sections at the Annual Meeting.

In the SUPPLEMENT of March 5th, 1921, at p. 65, we printed the provisional programme of the Annual Meeting of the British Medical Association to be held at Newcastle-on-Tyne in July next. We are now able to give the dates on which the two-day sections and the one-day sections will meet.

Two-day Sections.

Neurology and Psychiatry ...	July 20th and 21st
Obstetrics and Gynaecology ...	July 21st and 22nd
Ophthalmology ...	July 21st and 22nd
Oto-Rhino-Laryngology ...	July 20th and 21st
Physiology, Pharmacology, Therapeutics and Dietetics ...	July 20th and 21st
Veneral Diseases ...	July 20th and 21st

One-day Sections.

Ambulance and Red Cross ...	July 20th
Dermatology ...	July 21st
Medical Sociology ...	July 22nd
Proctology ...	July 20th
Radiology and Electro-therapeutics ...	July 22nd
Urology ...	July 22nd

The following five sections will meet on each of the three days: Medicine, Surgery, Pathology and Bacteriology, Preventive Medicine with Industrial Diseases, Orthopaedics and Diseases in Children.

Medical Books for Serbia.

In a Current Note in the SUPPLEMENT of July 17th, 1920, a short account was given of the plight of the Serbian libraries after the war, and of the effort being made to reconstruct them. In this endeavour the Royal Society of Literature sought the help of the British Medical Association, and a letter from a subcommittee of the Society was considered by the Science Committee. In accordance with the instructions of the Committee the librarian prepared a list of surplus books which the Association could supply towards restoring the ruined libraries in Belgrade and other Serbian towns. This list was forwarded to the Serbian Library Section of the Royal Society of Literature. At the last meeting of the Science

Committee the librarian reported that some fifty volumes had been chosen, and would in due course be forwarded to the Serbian Library Section. By the gift of standard English works it is hoped to promote the study of our own literature and science where these have hitherto been too little known. A medical faculty of the University of Belgrade is being established, and an English medical library will be of special value to the students and staff.

MUNICIPAL CLINICS AND THE PRIVATE PRACTITIONER.

CONFERENCE OF COMMITTEES OF THE BRITISH MEDICAL ASSOCIATION.

A CONFERENCE of the Medico-Political, Public Health, Hospitals, and Ministry of Health Committees of the Association was held in the Council Room at 429, Strand, on March 16th, to consider the question of municipal clinics and hospitals, and the relations thereto of medical officers employed by municipal authorities and of private practitioners. There was a large attendance. Dr. R. A. BOLAM (Chairman of Council) presided, and, in opening the proceedings, mentioned that Dr. G. F. BUCHAN and Mr. H. S. SOUTTAR attended by invitation on account of their special interest in the subject under discussion.

A motion was proposed by Dr. E. J. MACLEAN affirming the desirability of finding a means of reconciling the differences between medical officers employed in municipal clinics and hospitals on the one hand and practitioners in related areas on the other.

Dr. H. B. BRACKENBURY said that in posing the problem before them he would start from the fundamental position—which he could not imagine the Representative Body ever going back upon—that it was the business of the private practitioner to treat the members of the public. The question was how far this general proposition might be limited or modified in special circumstances, and also how far it was possible to associate the private practitioner with the advance of preventive medicine in a wider aspect than its purely individual and domestic concerns. Unless they took it for granted that in general the private practitioner was to do the treatment and the whole-time officer attend to administration, he saw no possibility of harmony, though he could quite believe that each side of that proposition might need some modification.

Dr. G. F. BUCHAN began by dealing with certain matters relative to the municipal clinics and hospital in Willesden. The clinics were supported from the rates, and the feeling of all parties on the local council was that institutions supported from the rates should be available to all ratepayers. These clinics were not the crotchets of himself as medical officer: they were the outcome of the developments in public health legislation extending over the last forty years. In these clinics the clinic medical officer was the pivot of the whole organization. He dealt with a definite area and section of the population, had specified hours of work and salary, and had at his back the specialist and the hospital; the officer himself was a general, though not a private, practitioner. Dr. BUCHAN thought that if part-time service was introduced it must be thoroughly understood that the part-time officer was willing to accept responsibility, and to give a large amount of time—not much less than half his time—to the work. He must realize that the organization depended largely on him for maintenance and initiative. Furthermore, the part-time service must be on the same economic level as the whole-time service in the matter of cost to the ratepayers. He did not believe that administration could be separated from treatment, although the work of some men would be in its major part administrative, and the work of others in its major part clinical. He regarded it as peculiarly the business of the British Medical Association to try and make practical the ideals of Lord Dawson's report.

Mr. BISHOP HARMAN said that medical officers of health naturally stood for organization and private practitioners for freedom. The two positions were not incompatible with the public health ideal, but the attitude taken up by many on one side or the other was incompatible. An organization grew by accretion, swallowing up first one province and then another, until it might become unwieldy and embarrassed in action. He appealed to medical officers to recognize human nature, to preserve freedom as far as possible, and adapt existing circumstances rather than seek violent change.

Dr. Maclean's motion was agreed to unanimously, and a further motion was proposed by Dr. BRACKENBURY

urging that wherever possible a part-time service for municipal clinics should be provided.

Dr. BRACKENBURY said that those on his side did not differ from Dr. BUCHAN in his contention for the municipal clinic, but they thought that the means already to hand in the shape of the private practitioners of the locality ought to be utilized. Medical inspection might be left in the hands of administrative whole-time officers, but the treatment of the individual should remain, wherever possible, with the private practitioner. There was no difference as to the need for specialization. Nobody had stated that all medical practitioners were capable of doing all work, but when a man had done a thousand tonsils and adenoids cases he could do them as well as the man who had done five thousand. Given a certain degree of experience, relative efficiency ceased to matter. He agreed that a part-time man must do his agreed public work punctually and regularly, and allow no exigency of private practice to interfere.

Dr. ROCYN-JONES said that in his area part-time service had failed because the clinics had been secondary to his private practice in the practitioner's estimation. He did not believe that inspection and treatment could be divorced.

Dr. Brackenbury's motion was withdrawn, and the following was carried *nemine contradicente*, on the motion of Mr. BISHOP HARMAN:

That it is desirable in the interests of harmonious working, both from the public and professional standpoints, that clinical work done for the public health authority should, wherever possible, be carried out through the agency of private practitioners, subject to conditions to be agreed upon.

The CHAIRMAN suggested that the Conference should now consider the method to be adopted by the local authority in connexion with the treatment of a child found upon inspection to be defective. A memorandum was presented dealing with this subject, and special attention was directed to a suggested method:

The child should be given a note to hand to his parent stating the condition for which treatment is required, with the advice that the family doctor should be consulted thereon. A letter addressed to the family doctor should accompany the note to the parent, describing the condition found on inspection, and the doctor should at the same time be furnished with a post-card on which he should be asked to state his willingness or otherwise to treat the case. If the doctor agrees to treat the case it may be assumed that he is of opinion that the parents can pay, or at any rate that he is willing to take the risk. The responsibility of the education authority would then cease until such time as the child is again inspected. Should the school medical officer not be satisfied with the result of treatment the private practitioner should be offered an opportunity of consultation. If the family doctor prefers not to undertake treatment, or if there is no family doctor, the child should be treated at the clinic.

Dr. SNELL said that practically the same method had been tried in Coventry, but it was found that it did not work, chiefly because the private practitioner did not carry out the treatment of cases referred to him, as in many instances he did not consider it necessary. He (Dr. Snell) was of opinion that the amount of work taken out of the hands of private practitioners owing to the activities of the local authority was very small. Most of the work done by clinics never had been done by private practitioners, and the existence of the clinics, by raising the standard required as regards the health of children, had caused many children to be taken to private practitioners who would not otherwise have come under their treatment.

Dr. R. A. LYSTER regarded the method suggested as ideal, but from his own experience in Hampshire there were difficulties in carrying it out; a considerable number of practitioners resented the sending of a statement from the local authority to the parents giving the diagnosis, as it might suggest that private practitioners did not know their business. Any authority which tried to recover the cost of treatment wasted more money over the attempted recovery than the treatment actually cost. Medical inspection and treatment of school children by local authorities had increased the work of private practitioners. The employment of part-time officers was disliked by public authorities and was unpopular with the public. Such appointments had been tried and found to be unsatisfactory. Practitioners as a whole were, moreover, very suspicious of the part-time officer who was also in private practice.

Dr. A. LYNDON felt that the inspection of school children, which the profession ought to welcome, could only be done by whole-time officers. The practitioners in his area had no desire to carry out such inspection. Dr. BRACKENBURY agreed that inspection was better done by

whole-time than by part-time officers, but he was anxious about procedure immediately after inspection. A defective child should, in the first instance, be referred to a private practitioner if the parent was willing to engage one. Dr. C. SANDERS instanced the practice in his own area, where the parents nearly always attended at the inspection, and were advised immediately to consult a private practitioner when necessary.

Mr. BISHOP HARMAN suggested the following modification:

That a note should be sent to the parent stating that the child was suffering from certain defects, with a request that the family doctor be consulted, along with the statement that if the family doctor did not treat within a certain time treatment would be carried out at the school clinic.

He believed that clinics often resulted in children being taken to the private doctor in order to confirm the advice or suggestions given.

Dr. C. E. S. FLEMING thought that provision should be made in rural areas for consultations between private practitioners and the school medical officer. Dr. BUCHAN thought that only a small percentage of the letters sent from the school clinic would ever reach the practitioner, and in his experience very few parents attended the inspection of their children.

Ultimately the Conference unanimously resolved:

That in every case where defect is discovered on medical inspection a communication should be made to the parent, notifying him of the necessity of treatment and advising the calling in of a private practitioner.

On the motion of Dr. BRACKENBURY, seconded by Dr. DOMVILLE, it was also unanimously agreed that a form be prepared by the British Medical Association and the Society of Medical Officers of Health on which such communication could be made when necessary.

Certain resolutions were then passed with regard to the setting up and the staffing of the clinics:

- (1) That the giving of advice and treatment at school clinics should, wherever possible, be by the private practitioners of the area;
- (2) that the practitioners of the area should have the right themselves to refer cases to the school medical officer for treatment;
- (3) that home treatment undertaken by health visitors or nurses under the direction of medical officers who themselves are not in domiciliary attendance should be specifically limited by the directions of the medical officer.

With a view to carrying out the first of these resolutions the local authority, through the medical officer of health, should invite the medical practitioners to submit a scheme, and in the event of this scheme not being accepted by the local authority, or of a modification of it not being accepted by the practitioners, a conference should if possible be held for the adjustment of details.

Several matters were left over owing to the lateness of the hour, and it was left to the discretion of the Chairman to summon the Conference again if and when it seemed desirable.

Association Notices.

SCHOLARSHIPS AND GRANTS IN AID OF SCIENTIFIC RESEARCH.

SCHOLARSHIPS.

THE Council of the British Medical Association is prepared to receive applications for Research Scholarships as follows:

1. An ERNEST HART MEMORIAL SCHOLARSHIP, of the value of £200 per annum, for the study of some subject in the department of State Medicine.

2. THREE RESEARCH SCHOLARSHIPS, each of the value of £150 per annum, for research into some subject relating to the Causation, Prevention, or Treatment of Disease.

Each scholarship is tenable for one year, commencing on October 1st, 1921. A Scholar may be reappointed for not more than two additional terms.

The Conditions of the award of Scholarships are stated in the Regulations, a copy of which will be supplied on application to the Medical Secretary of the Association, 429, Strand, London, W.C.2.

GRANTS.

The Council of the British Medical Association is also prepared to receive applications for Grants for the assistance of Research into the Causation, Treatment, or Prevention of Disease. Preference will be given, other things

being equal, to members of the medical profession, and to applicants who propose as subjects of investigation problems directly related to practical medicine.

The Conditions of the award of Grants are stated in the Regulations, a copy of which will be supplied on application to the Medical Secretary of the Association, 429, Strand, London, W.C.2.

Applications.

Applications for Scholarships and Grants for the year 1921-22 must be made not later than Saturday, June 25th, 1921, in the prescribed form, a copy of which will be supplied by the Medical Secretary on application.

Each application should be accompanied by testimonials, including a recommendation from the head of the laboratory, if any, in which the applicant proposes to work, setting out the fitness of the candidate to conduct such work, and the probable value of the work to be undertaken. This is not intended, however, to prevent applications for Grants in aid of work which need not be performed in a recognized laboratory.

ELECTION OF COUNCIL OF ASSOCIATION, 1921-22.

A LIST of the Groups of Branches in the United Kingdom for election of twenty-four Members of the Council, 1921-22, and *Nomination Form*, were published in the SUPPLEMENT of March 12th (p. 73). The *Nominations* must be in the hands of the Medical Secretary **by May 16th**.

The result of the election for Members of Council by the Groups of the Oversea Branches was published in the SUPPLEMENT of February 19th, 1921.

ELECTION OF REPRESENTATIVE BODY OF ASSOCIATION, 1921-22.

Constituencies in Representative Body.

THE Council has finally grouped the *Home Divisions* for election of the Representative Body, 1921-22, in the same manner as for 1920-21, except that the Caithness and Sutherland Division of the Northern Counties of Scotland Branch, and the Rotherham and Sheffield Divisions of the Yorkshire Branch have been made independent Constituencies.

As intimated to all the *Oversea Bodies*, the Council has made each Oversea Division and Division-Branch an independent Constituency.

Election of Representatives and Deputy-Representatives.

THE REPRESENTATIVES AND DEPUTY-REPRESENTATIVES in the Representative Body must be elected not later than **June 17th**, and their names notified to the Medical Secretary **not later than June 24th**. The Annual Representative Meeting at Newcastle begins on July 15th.

Special attention is drawn to the fact that the election of Representative(s) and Deputy-Representative(s) may, at the discretion of the Constituency, be carried out by General Meeting of the Constituency, or by postal vote.

MOTIONS FOR ANNUAL REPRESENTATIVE MEETING, NEWCASTLE, JULY, 1921.

NOTICES OF MOTION by Divisions, Constituencies, or Branches, for the consideration of the Annual Representative Meeting of the Association, commencing Friday, July 15th, 1921, proposing to make any addition to, or any amendment, alteration, or repeal of, any Article or By-law, or to make any new Article or By-law, or proposing material alteration of the policy of the Association in matters relating to the honour and interests of the profession or of the Association, must be published in the BRITISH MEDICAL JOURNAL SUPPLEMENT not later than May 14th, and for this purpose should be received by the Medical Secretary **not later than April 30th**.

LIBRARY OF THE BRITISH MEDICAL ASSOCIATION.

A LIST of periodical publications, official reports, and Blue Books in the Library of the British Medical Association available for issue to members on loan has been printed, and copies can be obtained free on application to the Librarian at the house of the Association, 429, Strand, W.C. The regulations governing the loan of these publications are stated in the introduction to the list. The Library is open for consultation from 10 a.m. till 6.30 p.m. (on Saturdays 10 a.m. till 2 p.m.).

Meetings of Branches and Divisions.

GLASGOW AND WEST OF SCOTLAND BRANCH.

THE annual meeting of the Branch was held on March 16th, when Dr. LIVINGSTONE LOUDON, President, was in the chair. The following office-bearers were elected:

President: Dr. C. E. Robertson. *President-elect:* Dr. G. Douglas McKee. *Vice-Presidents:* Drs. Snodgrass and Livingstone London. *Honorary Secretary:* Dr. J. Russell. *Honorary Treasurer:* Dr. W. O. Taylor.

The retiring secretary, Dr. A. Kennedy Glen, was accorded a hearty vote of thanks for his services throughout the past two years, during which time the membership of the Branch has considerably increased.

Annual Meeting, Glasgow, 1922.—The retiring PRESIDENT, in demitting office, thanked the members for the honour they had done him and congratulated the Branch on its increasing strength. The ensuing year, he said, would be a busy one preparing for the Annual Meeting of the Association, but he was sure that members would take up the work enthusiastically and carry it through successfully. They had reason for congratulation in having obtained Sir William Macewen's consent to his nomination as President. Some discussion followed as to the method of appointing a general committee, and it was ultimately resolved that a preliminary committee be formed consisting of the members present, together with the Branch Council, with power to add to their number.

METROPOLITAN COUNTIES BRANCH: WILLESDEN DIVISION.

A MEETING of the Division was held on March 15th, with Dr. J. S. CRONE in the chair.

The Honorary Secretary (Dr. W. PATERSON) read a letter of protest forwarded to the Home Secretary, pursuant to the instructions of the last meeting, with respect to the Dangerous Drugs Regulations, and a communication from Colonel Pinkham, M.P., regretting that illness prevented him taking any immediate action in the matter. The Secretary reported a very successful meeting of members of Parliament which had been arranged by the Association and the Pharmaceutical Society, with the result that the Government had appointed a committee to go into the whole question.

The Secretary reported that the questionnaire on medical inspection and treatment of school children, maternity and child welfare work, had been issued to 50 members and 55 non-members; that there were 52 replies, of which 36 expressed a positive opinion.

Of the 36 replies 24 were willing (12 were not) to undertake on a part-time basis the medical inspection of school children. In answer to Question 2—namely, whether they desired to undertake on a part-time basis the medical treatment of school children, and, if so, what branch of the work they were willing to undertake—22 were willing (14 were not) to undertake the treatment of minor ailments; 12 were willing (24 were not) to undertake operations for adenoids and tonsils; 13 were willing (23 were not) to administer anaesthetics for tonsils and adenoids; 24 were willing (12 were not) to administer anaesthetics for dental operations; none of the 36 were willing to undertake the treatment of ringworm by x-rays. In answer to Question 3, 13 were willing (23 were not) to undertake on a part-time basis the treatment necessary at maternity and child welfare clinics.

The meeting considered the question of the formation of a Practitioners' Mutual Help Scheme, and Dr. SCOTT explained what was being done in Middlesbrough, Sheffield, and other places in connexion with the provision of locumtenents for holidays, etc., and explained the scheme issued by the head office. The meeting expressed general approval of the formation of such a scheme, and appointed a subcommittee to consider and report upon the matter.

Dr. SKENE, in introducing a discussion on clinical meetings and a medical club, stated that, while it was necessary for the Division in looking after the interests of the local practitioners to hold many meetings the business of which must of necessity be of a medico-political character, he felt that the Division should take action in the matter of arranging clinical meetings and discussions and, if possible, a social club. He did not desire to suggest anything elaborate, but rather that the clinical meetings should be discussions by the local practitioners of any matter of interest which they might come across in their own practice, or which would be of interest to themselves or their colleagues in their everyday work. In order that the meetings should not be too dry, he suggested that something of a social character should be also arranged.

Dr. STURRIDGE was strongly in favour of the project and spoke as to the interesting and successful clinical meetings held by the medical officers of the divisions of the army to which he was attached at Malta and with the Rhine Army of Occupation. Dr. MACEVOY and others supported the suggestion, the former stating that the original Willesden Division arose out of the old Willesden Medical Society. He thought it only fair that the Honorary Secretary should be relieved from any work which might arise out of the clinical side of the Division's activities.

The CHAIRMAN stated that it was only the stress of medico-political work which had shelved the question of arranging the clinical work of the Division, and that the Division rules already provided for the holding of such meetings and the appointment of a clinical secretary. It was agreed that clinical meetings should be arranged for, and that Dr. Skene be appointed Clinical Secretary for one year.

It was unanimously resolved that the Division approve the candidature of the Secretary (Dr. Paterson) for election to the Central Council.

ESSEX BRANCH: SOUTH ESSEX DIVISION.

AT a meeting of the South Essex Division of the British Medical Association Dr. HERBERT FRENCH, of Guy's Hospital, read a paper on "Some clinical bits and pieces."

He advanced the emphatic opinion that acute nephritis did not occur without a cause, such as the chemical reaction to a foreign protein, as exemplified in puerperal eclampsia, or the presence of a focus of sepsis in some region of the body, as exemplified in scarlet fever and other exanthemata, and also further in a series of fourteen cases of tonsillitis which had recently come under his notice. These cases all showed the classical symptoms of acute nephritis—fever, albuminuria, oedema, and in one case haematuria and casts. They were all cured—the urine was free from albumin, and the patient quite well within at the most ten days—by enucleating the tonsils.

Dr. French then called attention to a condition often misdiagnosed as "calcareous rheumatism," but really due to a spicule of bone on the plantar surface of the os calcis, perhaps due to ossification of tendon or ligament. X rays would clear up the diagnosis and would sometimes show a tendency to shadow in the tendo Achillis as well. Treatment would be either surgical removal of the spicule or the formation of a groove inside the heel of the boot.

In regard to pyloric stenosis, non-malignant, produced by the fibrosis resulting from the scar of a healed gastric ulcer, he suggested that it did not give rise to vomiting until a late stage of the condition. He expressed the opinion that the development of contraction was such a slow process that in some cases the musculature of the stomach wall was able by hypertrophy to keep pace with the obstruction due to increasing narrowness of the pyloric orifice for years before giving up the struggle and resorting to ejection of the stomach contents instead. The condition could be definitely diagnosed only by serial x-ray examination after bismuth meal. Early gastroenterostomy was highly satisfactory before vomiting supervened, but not by any means so successful after the onset of vomiting.

He pleaded for a sane use of thyroid extract, which he strongly recommended as alleviative if not curative in tic douloureux, and the periodic sick headaches of women. He detailed illustrative cases, and incidentally drew attention to the nervous symptoms of myxoedema which would also be controlled by thyroid extract. As examples, he spoke of two patients who both presented a sign which he regarded as pathognomonic of myxoedema—the peculiar gelatinous appearance of the tissues between the eyelid and the eyebrow on the outer half of each eye. One case alternated melancholia with acute mania, and the other presented the symptoms of multiple peripheral neuritis. Both cases were able to resume their ordinary duties after three or four weeks' thyroid medication.

Discussions took place on each of the four points raised by Dr. French, who was heartily thanked for coming to speak.

INSURANCE.

CORRESPONDENCE.

Insurance Envelopes and Cards.

SIR,—The Minister of Health, acting on the advice of a special committee, has decided that both clinical and statistical records are necessary, and that the former are the most essential and important. To carry this out the envelopes and cards have been devised and sent to all insurance practitioners with instructions for filling in details.

Statistics have always been based on the returns of the year, and there is no indication that this basis will be altered. Is it intended that the envelopes and cards are to be sent every year to the Insurance Committee for statistic tables to be drawn up?

The clinical records are to be kept on the same envelopes and cards, and to be retained until the patient dies, or is transferred to some other medical man, in the hands of the medical attendant?

If they have to be sent each year for the purpose of statistics they will necessarily be kept a long time to tabulate, etc., and meanwhile the medical man will be without envelopes or cards to continue his entries. What is he to do in order to carry on the records?

It looks as if this had escaped the attention of the Committee and the Insurance Commissioners; at any rate they have not sent instructions for this dilemma, and unless they have some means of overcoming the chaos they will have to alter the single record arrangement and have separate cards for statistics and for clinical history and report of treatment, etc.

The old white cards in use till this year were well adapted for statistical purposes. The name, address, society, etc., and place for notes and treatment, on one side, and the space for each day of the year ruled on the other, with age, occupation, and nature of illness at the

lower half. But these cards were called in each Christmas, and then the medical men had a very heavy task to fill up new cards for the ensuing year. They also lost their records of illnesses, treatment, etc., of the past year and years.

The modern envelopes and cards are not suited for statistical purposes. Flimsy and difficult to handle, they will soon wear out and be a constant worry. The having to write on the back of the envelope is a mistake; and the ruling is most inconvenient—insufficient space for anything and no place for record of treatment.

What can be done to improve matters? The old white cards might be reissued for statistical purposes, and could be sent up every year. The new buff cards could be much improved, and then used only for clinical notes, records of treatment, and diagnosis, etc. In any case, the unfortunate medical man will have the trouble of much more writing, many more cards, and the expense of providing cabinets or boxes for the increased cards.—I am, etc.,

Twickenham, March 24th. H. HOWARD MURPHY, M.D.

LOCAL MEDICAL AND PANEL COMMITTEES.

COUNTY OF LONDON.

At a meeting on March 22nd, 1921, the London Panel Committee passed the following resolutions:

- That the Committee are of opinion that some form of medical record is necessary.
- That the Committee are of opinion that practitioners should not be required to enter matters on the record cards which in their opinion are likely to be detrimental to the interests of the insured persons concerned.
- That in the opinion of the London Panel Committee the present medical records are neither advantageous to the medical service nor beneficial to the community, and that it is desirable that they be discontinued forthwith.

THE FUTURE OF THE MEDICAL SERVICES IN CHESTER AND THE DISTRICT.

BY

JOHN ELLIOTT, O.B.E., M.D., F.R.C.P.,
HONORARY PHYSICIAN, CHESTER ROYAL INFIRMARY.

A LITTLE while ago I happened to be travelling with a colleague when we fell to talking of the prospects of medical practice. My estimate of the position was not exactly rosy, but the pessimism of my companion was unqualified. I hinted to him that I contemplated an incursion into the troubled waters of medical politics on the lines of the present discussion. He said, "Why should you or I move in the matter when the younger generation of practitioners, whom it more intimately concerns, will not even take the trouble to consider it?" He went on to tell me that out of some 600 medical men in his district 12 only attended a meeting called in their interest. This is a weighty indictment, but, I am pleased to say, cannot be urged against the profession in Chester and the neighbourhood, and the attendance here to-day is sufficient justification of the subject which I suggested for discussion.

The National Insurance Act.

The causes which have led up to the changed outlook for medical practice are so recent and so well known to all of you that I shall not waste your time by even mentioning them.

The National Insurance Act has come to stay, and yet we cannot part with the old system of club practice without a tinge of passing regret. It may be different in large industrial centres, but in country agricultural districts, such as ours, the old club practice offered advantages which no other system can surpass. As I have so frequently seen, the club patients in the surgeries of our country doctors were not merely individuals—they were friends. Under any State system I think they are more likely to be regarded as "cases," and it has been suggested that their doctor may be required to give damaging evidence against them in a court of law, either with or without the production of their record cards. The profession would welcome a definite pronouncement from Dr. Addison on this matter and any legislation that may be necessary to ensure the confidential character of the relation between doctor and patient. The Insurance Act has made no provision for hospital treatment of insured persons, but

it is sufficiently evident that the voluntary hospitals can no longer undertake such treatment without remuneration. The London Hospital has declined to do so unless the approved societies come to its aid. Let us hope that the surplus millions now in the hands of these societies may be utilized for such a purpose. It is evident from Dr. Addison's latest pronouncement that he has this matter under favourable consideration.

So much for the persons whose incomes entitle them to the benefits of National Insurance. They are adequately provided for. The crux of the situation centres round the provision of adequate medical treatment, both general and specialist (in the widest sense of the word), for the lower middle classes, whose incomes will not stand the strain of consultation and operation fees and nursing home charges.

The Poor Law Infirmaries.

The Poor Law infirmaries have now a large number of vacant beds. Strange to say, during the course of the war poverty has to a large extent vanished from our midst, and yet the everlasting truth, "the poor we have always with us," still holds good. The scene has shifted, and under very efficient and thorough taxation it is we ourselves who are the poor, and in my opinion we shall be poorer still before we are much older unless we are "up and doing." In Bradford the guardians have handed over their charge of the infirmary to the municipal authorities, the Poor Law infirmary thus becoming a municipal hospital with a whole-time medical service.

In other places they have opened them for the reception of paying patients, providing maintenance and treatment of every description at a very moderate cost—as, for example, in Manchester, where 200 beds have become available in Withington and Crumpsall Infirmaries, the contribution of three guineas per week entitling patients to maintenance and full medical service. Again, the guardians of the West Derby Union, Liverpool, at the request of the Chairman of the Middle Classes Union, Liverpool branch, have opened wards for the reception of paying patients on similar terms to those charged by the Manchester Poor Law infirmaries mentioned. It would be well to note carefully the conditions of service (BRITISH MEDICAL JOURNAL, February 5th, 1921, p. 209). The private medical attendant can consult with the medical staff of the infirmary, but no interference will be allowed either in the treatment or nursing of the patient. The staff consists of a medical superintendent, three resident medical officers, and a visiting staff of specialists. Patients will be admitted either on the recommendation of their own doctor, or on the personal application of the patient or his friends.

There can be no question that this constitutes a direct challenge to the position of the general practitioner, and if the practice is extended, as seems highly probable, it will very largely relieve him of the care and treatment of his own patients. I gather, however, that this procedure on the part of the Poor Law guardians has not yet received the sanction of the Ministry of Health.

Unless we take immediate steps to provide an efficient and complete medical service, including hospital accommodation for persons of moderate income, the prospects of the general practitioner are gloomy in the extreme.

Increasing numbers of students are flocking to our universities and medical schools, which are overcrowded already. At my old hospital (St. Bartholomew's) 150 full term students entered in 1920; in 1919 there were 161 entries; in previous years the entries numbered about 100. No doubt the previous shortage was due to war service, whilst its resulting post-war influx accounts in some measure for these figures, but the fact remains that our profession is attracting a very large number of students, both men and women. On inquiry of the General Medical Council I find that 1,457 students obtained a qualification to practise medicine in 1920. What is to become of the majority if, as seems probable, the medical care of the lower middle classes is to be largely taken out of our hands either by the Poor Law guardians' activities or by an extension of the principle of compulsory national insurance?

Before taking leave of the subject of the Poor Law infirmaries I would draw attention to a very able article on "Industrial Hospitals" by Dr. Bolam and Mr. Orde.† The authors advocate the use of the vacant Poor Law beds for (1) workers incapacitated by industry; (2) workers unable through curable disabilities to do full work: the costs of maintenance, etc., to be defrayed by contributions from both employers and the workers themselves, there being no burden on rates or taxes. This seems to me to be an altogether admirable suggestion.

* An address delivered at a meeting of practitioners under the auspices of the Chester and North Wales Medical Society, March 2nd, 1921.

Schemes for Providing Health Service.

I propose briefly to consider various schemes which have been either suggested or established with a view to the provision of an efficient health service by the general body of the medical profession itself.

Medical Consultative Council.—A diagram of the scheme propounded in the interim report of the Consultative Council on Medical and Allied Services was shown and explained, and Dr. Elliott went on to express the opinion that it would in many respects be an ideal scheme if unlimited financial support were forthcoming. Under present conditions he thought it out of the question.

The Gloucestershire Scheme was also illustrated by a diagram. I find the financial clauses of this scheme somewhat difficult to understand, and in any case I am sure we shall all agree that, like the scheme of the Consultative Council, it is much too ambitious for us to contemplate in this district. I hear from Dr. Middleton Martin, M.O.H. for Gloucestershire, to whose initiative the scheme is due, that it is not yet in operation, so that it is impossible for us to judge of its working.

Schemes for Medical Insurance.

The Sussex Provident Scheme is applicable to insured persons, and those whose income does not exceed £260 for single members, and £500 for a family. Benefits: Consultations, hospital treatment, dental treatment, laboratory, x-ray, massage, and electrical treatment. Subscriptions: £1 per annum for single members; for a married couple without children, 30s.; family rate, £2. Children over 16 years old counted as single members. For details of the scheme see BRITISH MEDICAL JOURNAL, January 22nd, 1921.

Leicester also has a provident scheme. Of the details of this I have no knowledge.

Co-operative Polyclinic for London, suggested by Mr. Parker, F.R.C.S. (*Lancet*, February 5th, 1921), with a maximum income limit of £2,000. Premium from £1 to £12 per year according to income. A private company to finance the scheme. I feel sure this scheme will not commend itself to you.

One great advantage of provident schemes is that the voluntary hospitals would benefit by them; in fact, if feasible and applicable to all areas, such a scheme would go far towards solving the financial problem of the voluntary hospitals. The Sussex scheme seems to me to be an ideal one for a limited community in a compact area. It can only be successful if the great majority of eligible persons become members.

The difficulties inseparable from the organization of a provident scheme in a district such as ours seem to me to be insurmountable.

It is not improbable that a considerable extension of the insurance principle may be in contemplation in the near future, either on voluntary or compulsory lines, so that it would be well to weigh carefully the very obvious advantages offered by a voluntary organization on the lines of the Sussex Provident Scheme.

I have now briefly described various schemes, either suggested or in operation, and have endeavoured to point out what in my opinion are their advantages and disadvantages; and have come to the conclusion that none of them are applicable to our immediate needs in this district. I have dealt with the matter from the point of view of the general practitioner. In my opinion the interests of the consultant and specialist are indissolubly linked with his, so that no special consideration from their point of view is necessary.

What can be Done in Cheshire and Flintshire?

In the first place, I am satisfied that in the event of any scheme being formulated the unit should be county council and county borough, but that if the Flintshire County Council and the Cheshire County Council agreed on a joint scheme the Ministry of Health would consider it favourably. It will be conceded that it is impossible at present to embark on any scheme which involves any great expenditure of public money. Our aim must be to forestall the kind intentions of the Poor Law guardians, and also any considerable extension of compulsory insurance, by providing for persons of moderate income a medical service which shall be equal in quality to that obtainable by anyone, whatever his income or advantages, and this with an eye to future contingencies in the way of linking up of various hospitals and other centres, and organizing the medical practitioners in the district for a complete health service, under which the general practitioner shall retain the care and treatment of his patients to the fullest possible extent.

Dr. Elliott showed a map of Cheshire on which the centres at present available for health service were marked and the accommodation they afforded and the uses to which they could be put indicated. After pointing out that the map showed that the district was in an exceptionally favourable position for the realization of a complete scheme, he made the following proposals:

1. The centralization of clinics as far as possible; such centralization not to interfere with existing centres for tuberculosis, maternity and child welfare, school clinics, etc. It must be obvious that the centralization of the various clinics must be an advantage both from the point of view of the local authorities, who will be saved much expenditure which would inevitably attend the acquisition of scattered sites and buildings, and from that of the medical practitioner, as being far more convenient for clinical study and teaching. It would also facilitate the formation of an extended scheme of health service in the future. The reconstruction of the Chester Royal Infirmary has provided much available space in wards not at present utilized, and is capable of almost indefinite extension in the way of separate huts or buildings on the site of the infirmary field.

2. The provision at cottage hospitals as well as at larger institutions of beds for paying patients, where they could be under the care of their own medical attendant, who could by arrangement with consultants or specialists procure any necessary special treatment. The provision of such beds would not involve serious outlay. In a small ward a few beds screened off with movable side screens would be all that is required. To do more than this in the present financial straits of the voluntary hospitals and the prevailing inflated prices in the building trade would be a costly mistake.

3. Similarly beds should be provided at all centres as far as possible for maternity cases; for cases in which difficulty is anticipated, or where operative interference is required; above all for cases whose home surroundings render the aseptic conduction of the labour impossible. The importance of this cannot be overestimated. I feel sure that the County Council would come to the financial aid of such a necessary procedure, and I hope the medical officer to the Council is prepared strongly to recommend such a course to his Council. It is a cause also which, I am convinced, would forcibly appeal to the benevolent. Since writing this I have read the leading article in the BRITISH MEDICAL JOURNAL of March 5th, p. 354, and would strongly recommend its careful perusal to those of you who have not already done so. I cannot refrain from quoting two paragraphs from that article: "Every general hospital should have a maternity ward or be associated with a lying-in hospital." Again, speaking of the "condition of the rooms where women are confined in poor and middle-class practices," it is said, "there is at present no possibility of getting all parturient women, or even all primigravidae, into a local cottage hospital or maternity ward."

4. Provision of a whole-time pathologist, whose headquarters should be at the Chester Royal Infirmary, but whose services should be available for any of the centres when required. The salary of such an officer could not be less than from £700 to £1,000 a year. If the authorities of the Chester Royal Infirmary agreed to such an appointment, his salary would have to be provided partly by the Royal Infirmary, partly by payment for public work done (Wassermann tests, etc.), and partly by contribution from the other centres which utilize part of his services. He should be at liberty also to undertake pathological work on the lines of private practice. I feel sure that Dr. Meredith Young would recommend his Council to help us financially with the salary of a pathologist. This matter would also, I believe, appeal to the city authorities.

5. An organized system of clinical lectures and demonstrations—to be held at any of the centres where interesting clinical material is available, and where any practitioner has matters of interest to communicate; the resources of special institutions, asylums, etc., to be available for this purpose, as also laboratory, x-ray, and electro-therapeutic departments. In this connexion I cannot do better than quote the weighty words of Sir George Newman ("The State and the Doctor," Cambridge meeting of the British Medical Association, July, 1920):

"In my view the State should never take out of the hands of the general practitioner—whether in contractual practice or otherwise—the patient whom he is willing and competent to handle on reasonable terms. The difficulty has been that the practitioner has not been in a position to render the medical service required by the State. It is evident that the solution is dependent partly on reform in the medical schools—a reform which, happily, is proceeding rapidly—and partly upon adequate arrangements for graduate education for the practitioner, and, may I add, willingness on his part to avail himself of the facilities which are provided? There is much remaining to be done in both directions; but before substantial progress can be achieved there is, first, considerable apathy to be overcome and a fuller appreciation of the needs of the situation; and, secondly, the further education of the practitioner must include an adequate professoriate, hospital and laboratory accommodation, and proper organization."

6. Organization of a system which would provide for special consultations or treatment at the wish of the general practitioner. This would present no difficulty, and needs no further notice.

7. The appointment of a representative committee to consider the best way of organizing a scheme on the lines suggested above when the circumstances are favourable, and when the co-operation of the local authorities can be obtained.

In conclusion, I wish to express my thanks to Dr. Meredith Young for his kind help, and for the hospital survey of the county which he undertook.

THE BRADFORD MUNICIPAL HOSPITAL.

THE following report of the Bradford Advisory Medical Committee, which had been considered in draft at a previous meeting held on February 10th, was adopted at a meeting of the medical profession of Bradford held on March 17th. The report, of which a copy has been forwarded to the Minister of Health and to the Bradford Health Committee, is signed by Dr. J. B. Dunlop, Chairman, Dr. J. Phillips, Vice-Chairman, and Drs. J. F. Allan, F. Beetham, R. A. Lankester, A. Manknell, G. H. Oliver, H. Shackleton, J. Wherry Wilson, W. Campbell, B. Hughes, J. V. S. Taylor, H. Vallow, and Dr. W. N. West Watson, Honorary Secretary.

Bradford Advisory Medical Committee's Report.

The Advisory Medical Committee, appointed by the medical profession of Bradford "to deal with the Health Committee on all matters relating to the public health of the city," has had under careful consideration the report of Dr. Buchan (medical officer of health) which was laid before the Health Committee, relating to the proposed establishment of a municipal hospital at St. Luke's. It has appeared to the Committee that the scheme before it is one which aims at establishing a municipal hospital of such magnitude that it will lead to the extinction of the existing voluntary institutions.

The discussion in Parliament and throughout the country of Clauses 10 and 11 of the now defunct Miscellaneous Provisions Bill showed that there was a very strong body of opinion averse from any steps being taken which would endanger the continued existence of voluntary hospitals.

Dr. Addison, Minister of Health, has several times stated that he is most anxious to do everything in his power to assist the voluntary hospitals to carry on, and it is also laid down in the Interim Report of Consultative Council on Medical and Allied Services that "We hope that the scheme that we have suggested will help these institutions, since these institutions are an essential part of the scheme." A non-medical committee has been appointed by Parliament with instructions to consider and report, at an early date, what measures can be taken to stabilize the position of the voluntary hospitals.

Conclusions.—The present would therefore appear to be a very inopportune time to launch an elaborate and costly scheme such as is proposed in Dr. Buchan's report, the carrying out of which would threaten the very existence of the voluntary hospitals in Bradford. The day when a tremendous struggle is required to ward off national bankruptcy hardly seems the best time to precipitate a crisis which must inevitably place a huge and permanent additional burden upon the rates.

Cost of Proposed Scheme.—In Dr. Buchan's report the number of beds available at St. Luke's Hospital is 1,148. The cost per bed per week at the Royal Infirmary is £3 12s. 6d. The cost to the Insurance Committee for a tuberculous patient at a sanatorium is £5 8s. 6d. per week. The Bradford Municipal Maternity Hospital costs very considerably more than either of the above. Calculating upon these data, the costs to the ratepayers of Bradford for the upkeep of St. Luke's Hospital would be at least £240,000 per annum. This sum means at least 16s. per head of the population of Bradford per annum. The inevitable result of a large addition to the rates, necessitated by this scheme, must be that many of the present supporters of the voluntary hospitals will not be able to continue their subscriptions, so that it will hardly be possible for these institutions to continue to exist.

Scope of the Scheme.—The present scheme also contemplates taking over work which is now being adequately performed by the existing voluntary hospitals and the medical practitioners of the city, thus producing an unnecessary and extravagant overlapping. This Committee, therefore, can only approve of the St. Luke's Hospital scheme in so far as it is necessary to complete the adequate provision for the institutional treatment of Bradford's sick.

Need for More Hospital Accommodation.—With regard to beds for in-patients, there is unquestionably a present deficiency, and this Committee would welcome the prospect of this being made up by the provision of a limited number of beds for general medical and surgical cases at St. Luke's Hospital.

Criticism of Proposed Accommodation.—The criticism of the number of beds set out in Dr. Buchan's scheme as being necessary at St. Luke's Hospital is based upon the following considerations:

(a) Sir Napier Burnett, who is the authority upon hospital matters, has estimated that three beds per 1,000 of population is the number required in an urban community: this would mean 900 beds for Bradford.

(b) Apart from St. Luke's Hospital, clinics and special hospitals, Bradford has in the three voluntary hospitals over 300 beds.

(c) Thus the number of beds required at St. Luke's Hospital is only 600, whereas the scheme provides for 1,148. Of the latter, 826 are allocated to medical and surgical cases, a number which closely approximates the total given in the above estimate as being necessary for the general requirements of the City.

(d) The number of beds allotted to the treatment of venereal disease is 108, which in the opinion of the Committee is unnecessary, inasmuch as very few venereal cases require in-patient treatment for more than a day or two, and the Ministry of Health has approved as adequate the accommodation and treatment now provided at the Royal Infirmary.

The question therefore comes to be whether the Health Committee intends to be content to supply only such accommodation and treatment as are at present not satisfactorily available; if so, by co-operating with the voluntary hospital boards, there will be no need for the full scheme as outlined in Dr. Buchan's report.

Special Departments. Turning to the question of special departments, the Committee considers that since there is abundant accommodation for the treatment of eye, ear, and throat cases at the Royal Eye and Ear Hospital, it is unnecessary to open a new department at St. Luke's Hospital, but rather that arrangements be made with the board of the Royal Eye and Ear Hospital for the treatment of St. Luke's cases. With regard to the suggested out-patient departments the Committee is of the opinion that no such departments are necessary, because, since the introduction of the National Health Insurance Act, with its provision for domiciliary treatment of ordinary illness, all voluntary hospitals have found that the work of their out-patient departments has been greatly reduced, and has assumed to a great extent a consultative character. The Committee considers that adequate provision for out-patient treatment is already made at the existing voluntary hospitals, and therefore it cannot see any justification for burdening the ratepayers with the cost of a new department of this kind at St. Luke's. As to casualties the Committee considers that as the casualty departments at the three voluntary hospitals are adequate and efficient for the City's needs, it is unnecessary to initiate a casualty department at St. Luke's Hospital. The Committee is also of the opinion that efficient x-ray and pathological departments should be established at St. Luke's, and also that experienced anaesthetists should be appointed. This would not preclude the general practitioner in the case from giving the anaesthetic if he and the surgeon so agree.

The Committee's Proposed Alternative Scheme.

Co-operation.—The Committee considers that the interests of the community will be best served by co-ordinating all the hospitals in the city—the three voluntary hospitals and St. Luke's Hospital—in such a way that each institution will become one branch of a conjoint hospital scheme. If this is to be accomplished it is essential that a joint board with executive powers shall be appointed, comprising representatives of each of the voluntary hospitals and of the Health Committee representing St. Luke's Hospital. While the internal affairs of each institution would continue to be administered by its own Board of Management, all matters which affected the hospitals as a conjoint institution would be dealt with by the joint board. This would include such matters as allocation of special work to a special hospital, and other methods and arrangements for avoiding overlapping; it would enable the Health Committee and its medical officer to receive first-hand information regarding the scope and accommodation of the voluntary hospitals, and the joint board would be a most important and useful body to discuss and determine such alterations as would be called for from time to time with regard to the provision for institutional treatment of Bradford's sick. The most urgently important function which such a board would be called upon to deal with would be the appointment of visiting staffs.

Staffing.—In the opinion of the Committee the best method of staffing would be a similar one to that which is satisfactorily working in the Paddington district of London. The Paddington district of London has an infirmary corresponding to St. Luke's, a general voluntary hospital and a children's hospital corresponding to our voluntary hospitals, and when the Poor Law infirmary was developed on lines somewhat similar to those proposed in Bradford, the visiting staff was appointed from the members of the staffs of the voluntary hospitals. At a discussion on the future of hospitals, held in London only a few weeks ago, the Medical Officer of Health for Paddington said of this arrangement: "The experiment of linking the local infirmary to St. Mary's Hospital has been so successful that there can be no doubt that such linking up will be general in the future." That some similar arrangement might be adopted with regard to the staffing of St. Luke's Hospital is the opinion of the Advisory Medical Committee. It would involve the enlargement of the staffs of the voluntary hospitals so that these would include all the men now doing consulting work in Bradford. The appointments would be open to all properly qualified medical practitioners. It could only be worked if a joint hospital board, such as the Committee has suggested, were set up with properly defined statutory powers, to include the nomination for election of applicants for any vacant posts on the staffs of any of the hospitals, selected after advertisement and after consultation with the Advisory Medical Committee. The actual appointments must, of course, be finally

made by the board of the hospital affected, or by the Health Committee in the case of St. Luke's, and in practice there is no likelihood of friction arising. When appointments are to be made to the staff of any hospital, it is customary for the lay members of the hospital board to be guided to their choice, to a considerable extent, by the opinion of their medical colleagues. With regard to appointments under this scheme, the joint hospital board would have the great advantage of the collective opinion of the medical profession, as voiced by the Advisory Medical Committee. This Committee has been democratically elected by the whole of the local medical profession, and it is felt that it is the body most capable of judging the relative merits of candidates for medical appointments.

Practitioners' Ward.—It is also considered desirable that beds should be set apart into which patients might be sent for treatment by their own medical attendants. The Committee suggests that the following conditions are necessary:

1. That the medical superintendent must have the right to decline to admit a case if he considers it to be unsuitable.
2. If a patient be in the ward over four weeks, a consultation must be held between one of the visiting staff and the practitioner in charge of the case.

Staff.—The Committee is of the opinion that in the first instance the following visiting staff would be necessary to carry out the work at St. Luke's Hospital efficiently: Four physicians, four surgeons, one obstetrician, one consulting ophthalmic surgeon, one consulting aural surgeon, one pathologist, one radiologist, two anaesthetists. This Committee is of the opinion that beds should be placed at the disposal of the tuberculosis officer of the city for cases requiring special observation. The Committee considers that for the best administration of the hospital it is not desirable that the medical superintendent of the institution should also act in the capacity of a member of the visiting staff, but that in consideration of the present circumstances this recommendation should not apply to the present administrator.

Admission.—The Committee believes that it will be the wish of the citizens of Bradford that only persons resident within the city boundaries shall be treated at the rate-maintained hospital, and that, as has been the custom with regard to Poor Law patients, contributions from patients or their relatives should be demanded according to their financial position. Patients from without the city should only be admitted if the total cost of their treatment and maintenance be met. Patients should be admitted to hospital only on the recommendation of a medical practitioner, except in cases of accident or emergency. Power to recommend patients to hospital should be expressly forbidden to all other parties.

Administration.—With regard to administration, the Committee is of the opinion that a hospital board should be constituted at St. Luke's Hospital to deal with the interior professional relations of the hospital and hospital arrangements, and that the hospital board should consist of the visiting staff, together with the superintendent of the hospital and at least four general practitioners appointed by the Advisory Medical Committee. Throughout its deliberations it has been the constant endeavour of the Advisory Medical Committee to produce a scheme which, while giving full consideration to the interests of the public health of the city by establishing an adequate hospital accommodation, shall, at the same time, be consistent with the economy so necessary at the present time. In this report the Committee has studiously avoided the mention of municipal clinics and health visitors, as it has not had time adequately to consider the evidence on which sound recommendations can be formulated. The Committee intends to embody in a further report its opinions and recommendations upon the general public health service of the city.

Naval and Military Appointments.

ROYAL NAVAL MEDICAL SERVICE.

The following appointments are announced by the Admiralty: Surgeon Commanders E. R. Glazebrook to R.M. Division, Chatham; H. St. C. Colson to R.N. College, Greenwich (temporary); K. H. Jones to the *Fisgard*. Surgeon Lieutenant Commander R. A. Brown to the *Southampton*. Surgeon Lieutenants E. St. G. S. Goodwin to the *Ganges* for R.N. Sick Quarters, Shotley; J. W. Tighe to R.N. College, Greenwich.

ARMY MEDICAL SERVICE.

Major General O. R. A. Julian, C.B., C.M.G., C.B.E., retires on retired pay.

ROYAL ARMY MEDICAL CORPS.

Lieutenant (temporary Captain) H. G. P. Armitage to be Captain. H. W. Street, late Captain C.A.M.C., to be temporary Captain. The following Captains relinquish the acting rank of Major: C. M. Gozney, M.C., G. D. Harding, C. R. Dudgeon, M.C. The following officers relinquish their commissions: Temporary Major M. H. Allen, and retains the rank of Major. Temporary Captain J. D. Judson, and retains the rank of Captain.

ROYAL AIR FORCE.

MEDICAL BRANCH.

J. H. Peck is granted a short service commission as Squadron Leader for a period of two years on the active list, with effect from and with seniority of March 1st. J. C. Johnson is granted a temporary commission as Flight Lieutenant, with effect from and with seniority of March 4th. Flight Lieutenant L. G. Davies relinquishes his temporary commission upon termination of his appointment.

TERRITORIAL FORCE RESERVE.

ROYAL ARMY MEDICAL CORPS.

Captain E. Hulme resigns his commission, and retains the rank of Captain.

DIARY OF SOCIETIES AND LECTURES.

ROYAL SOCIETY OF MEDICINE. *Section of Tropical Diseases and Parasitology*: Mon., 8.30 p.m., Dr. W. Broughton-Alcock: Laboratory Observations on Pansiclers with Malaria; Dr. H. C. Lucey: Large Mononuclear Leucocyte Count in Diagnosis of Malaria. *Section of Surgery—Subsection of Orthopaedics*: Tues., 5 p.m. Cases. *Section of Pathology*: Institute of Pathology, Charing Cross Hospital Medical School, Tues., 8.30 p.m., Mr. W. S. Cole and Dr. W. J. Adie: Quantitative Analysis of Gastric Contents; Mr. Cole and Miss J. Aynton: Post-operative Ketosis; Mr. J. E. Barnard: Demonstration of Structure of Bacteria; Dr. A. B. Rother: Agglutinins in Normal Serums for *B. enteritidis*, etc.; Dr. G. S. Wilson: Counting Viable Bacteria; Dr. H. B. Weir and Dr. Adie: (a) Infarct of Spleen; (b) Gumma of Heart; Dr. W. W. C. Topley, Mr. Barnard, and Dr. Wilson: Bacterial Cultures from a Single Cell; Drs. Topley and Weir: Lesions in Epidemic Diseases of Mice; Dr. Topley: *B. enteritidis* and *B. suis* group. *Clinical Section*: Fri., 5 p.m. Cases; 5.30 p.m., Dr. Ivor Davies: Hair Cast of Stomach and Gastro-intestinal Tract; Dr. M. Cassidy: Neoplasm of Lung.

ST. JOHN'S HOSPITAL, 49, Leicester Square, W.C.—Thurs., 6 p.m., Chesterfield Lecture by Dr. W. Knowles Sibley: Seborrhoea and Psoriasis.

POST-GRADUATE COURSES AND LECTURES.

GLASGOW POST-GRADUATE MEDICAL ASSOCIATION, Royal Samaritan Hospital for Women.—Wed., 4.15 p.m., Dr. W. D. Macfarlane: Gynaecological Cases.

MANCHESTER ROYAL INFIRMARY.—Tues., 4.30 p.m., Mr. W. H. Hey: Diagnosis of the Chronic Abdomen.

WEST LONDON POST-GRADUATE COLLEGE, Hammersmith, W.—Daily, 10 a.m. (and 2.30 p.m. Tues.), Ward Visits; 2 p.m., In- and Out-patient Clinics and Operations.

British Medical Association.

OFFICES AND LIBRARY, 429, STRAND, LONDON, W.C.2.

Reference and Lending Library.

THE READING ROOM, in which books of reference, periodicals, and standard works can be consulted, is open to members from 10 a.m. to 6.30 p.m., Saturdays 10 to 2.

LENDING LIBRARY: Members are entitled to borrow books, including current medical works; they will be forwarded, if desired, on application to the Librarian, accompanied by 1s. for each volume for postage and packing.

Departments.

SUBSCRIPTIONS AND ADVERTISEMENTS (Financial Secretary and Business Manager. Telegrams: Articulate, Westrand, London). MEDICAL SECRETARY (Telegrams: Mediscera, Westrand, London). EDITOR, *British Medical Journal* (Telegrams: Aitiology, Westrand, London).

Telephone number for all Departments: Gerrard 2630 (3 lines).

SCOTTISH MEDICAL SECRETARY: 6, Rutland Square, Edinburgh. (Telegrams: Associate, Edinburgh. Tel.: 4361 Central.) IRISH MEDICAL SECRETARY: 16, South Frederick Street, Dublin. (Telegrams: Bacillus, Dublin. Tel.: 4737 Dublin.)

Diary of the Association.

APRIL.

- 7 Thurs. Worcestershire and Herefordshire Branch: British Medical Association Lecture by Mr. P. L. Daniel, F.R.C.S., on the Differential Diagnosis of Acute Abdominal Conditions. South-Western Branch, Newton Abbot.
- 8 Fri. London: Medico-Sociological Committee, 2.30 p.m.

APPOINTMENTS.

BROWNIE, W. Barrie, M.D., F.R.C.S. Edin., Ophthalmic Referee to County Court Circuit No. 4.

LEECH, E. Bosdin, M.D. Cantab., F.R.C.P., Physician to the Manchester Royal Infirmary.

WHITEHEAD, Henry, M.D. Vict. Manch., D.P.H., Medical Officer of Health for Wigan, vice Dr. F. E. Wynne.

WOOD, W. Q., M.D., F.R.C.S.E., Assistant Surgeon to the Chalmers Hospital, Edinburgh.

UNIVERSITY COLLEGE HOSPITAL.—The following appointments are announced:—*House-Physicians*: M. H. K. Kane, J. C. Blake. *House-Surgeon*: T. A. Butcher. *Obstetric Assistant*: C. A. Kirton. *Casualty Surgical Officer*: R. O. Eades. *Third Assistant in the Throat, Nose and Ear Department*: G. C. Scantlebury.

BIRTHS, MARRIAGES, AND DEATHS.

The charge for inserting announcements of Births, Marriages, and Deaths is 9s., which sum should be forwarded with the notice not later than the first post on Tuesday morning, in order to ensure insertion in the current issue.

MARRIAGE.

MOGG—THOMPSON.—On March 24th, at St. John's Church, Mansfield, by the Rev. W. Bathurst Soole, Gordon C. F. Moga, B.A., B.Sc., M.R.C.S., elder son of H. W. French Mogg, to Annie Gladys Thompson, M.B., Ch.B., elder daughter of Mr. and Mrs. Sidney Thompson, of Stone Cross, Mansfield.

DEATHS.

EWAN.—At 99, Philip Lane, Tottenham, London, N., on March 2nd, William John Strachan Ewan, M.B., C.M., eldest son of the late Rev. William Ewan, M.A., of Fyvie U. F. Church, and of 93, Bon Accord Street, Aberdeen.

KENNY.—On March 9th, 1921, at The Grange, Wickersley, near Rotherham, Yorks, John Drought Kenny, M.D., Ch.M., R.U.J., formerly of Treton, near Rotherham.

PYE-SMITH.—On March 23rd, at his house in Ampthill, Beds, after three days' illness, Rutherford John Pye-Smith, J.P., F.R.C.S., late of Sheffield, aged 73. Funeral 29th inst., 2.30 p.m., at Ampthill.

SUPPLEMENT

TO THE

BRITISH MEDICAL JOURNAL.

LONDON: SATURDAY, APRIL 9th, 1921.

CONTENTS.

BRITISH MEDICAL ASSOCIATION.		PAGE			PAGE
CURRENT NOTES:					
THE INDIAN MEDICAL SERVICE	93	INSURANCE.		
COLONIAL MEDICAL SERVICES	95	CORRESPONDENCE	95
ANNUAL MEETING AT NEWCASTLE: RADIOLOGY SECTION	95	LONDON PANEL COMMITTEE	95
MILEAGE FEES FOR PENSION REFEREES	95	LONDON INSURANCE COMMITTEE	95
PAYING PATIENTS IN POOR LAW INFIRMARIES: POLICY OF THE MINISTRY OF HEALTH					
...	...	93	NAVAL AND MILITARY APPOINTMENTS		
ASSOCIATION NOTICES:					
SCHOLARSHIPS AND GRANTS IN AID OF SCIENTIFIC RESEARCH	...	94	DIARY OF SOCIETIES AND LECTURES		
ELECTION OF COUNCIL AND REPRESENTATIVE BODY, 1921-22	94	ASSOCIATION INTELLIGENCE		
MOTIONS FOR ANNUAL REPRESENTATIVE MEETING, 1921	94	POST-GRADUATE COURSES AND LECTURES		
MEETINGS OF BRANCHES AND DIVISIONS					
...	...	95	APPOINTMENTS		
			BIRTHS, MARRIAGES, AND DEATHS		
					96

British Medical Association.

CURRENT NOTES.

The Indian Medical Service.

THE promise made in response to the representations of the British Medical Association that the pay of the officers of the Indian Medical Service should be increased by 50 per cent. was in part fulfilled soon afterwards by the issue of a new scale for officers in military employment. A resolution of the Government of India fixing scales for officers in civil employment was, we are informed, published in India on March 3rd. The new scales, it is stated, were, in consultation with the Secretary of State, settled as long ago as February, 1920, and payments will be made with retrospective effect from January 1st, 1920. When the official text is received it will be carefully examined; judging from the account published in the *Pioneer Mail* of March 11th, the provisions of the resolution are complicated.

Colonial Medical Services.

At its last meeting the Dominions Committee of the Association had again before it a large number of questions affecting the Colonial Medical Services. The Committee took strong exception to the delay on the part of the Colonial Office in dealing with the recommendations of the Departmental Committee, the report of which is dated as long ago as July 1st, 1920. In its reply to the Association of November 15th, 1920 printed in the SUPPLEMENT of November 27th, 1920, p. 141, the Colonial Office stated that the report of the Departmental Committee had been transmitted to the Colonial Governments and that it was expected that the observations of the latter would be received in a few weeks. In these circumstances the Dominions Committee, on March 21st, drew the attention of the Colonial Office to the great uneasiness and dissatisfaction felt by the British Medical Association at the delay in dealing effectively with the recommendations contained in the report, and intimated to the Colonial Office that unless the Association received very definite and early assurance that the grievances complained of were being remedied, it would be impossible for the Association to refrain from active dissuasion of medical men who might be thinking of entering the Colonial Service. In a reply dated March 29th, the Colonial Office expressed regret that the expectation that the Colonial Governments would reply at an early date to the circular dispatch sending out the report of the Departmental Committee had not been fulfilled; that several replies had been received, but that some of the larger colonies had not yet answered, and that a telegraphic reminder had been sent to all whose opinion was likely to be of importance. The Colonial Office further stated that in one case it had been ascertained that the delay was due to the desire of the Governor to obtain a full and complete expression of

opinion from the Medical Department, and to the wish of the head of the Medical Department, in his turn, to ascertain the views of his subordinates; that the officers in question are scattered over a very large tract of country, and would naturally take time to consider and formulate their views on the report; that as soon as the replies are forthcoming from the more important colonies which have not yet answered, the whole question will be carefully considered; and that "the Secretary of State trusts that he will be able to arrive at a definite conclusion, at any rate on the main suggestions of the Committee, without further delay." The Association is now on the point of making further detailed representations to the Colonial Office. These will be reported in this column as soon as possible.

Annual Meeting at Newcastle: Radiology Section

The Chairman of Council and the President-elect have invited Dr. Robert Knox to become President of the Section of Radiology and Electro-Therapeutics at the forthcoming Annual Meeting of the British Medical Association at Newcastle-on-Tyne, in place of the late Dr. W. Ironside Bruce, and Dr. Knox has accepted the post.

Mileage Fees for Pension Referees.

In February the Ministry of Pensions Subcommittee learned that the Ministry of Pensions was contemplating a reduction in the fees paid to medical referees in respect of mileage. A letter was sent to the Ministry pointing out that the proposed reduction was neither necessary nor reasonable, seeing that the cost of travelling was still very high. The Ministry of Pensions replied that the revised fees had been drawn up after due consideration of all the circumstances, and expressed regret that the suggestion made by the British Medical Association—that the old scale should be continued—could not be adopted. The chief reduction in the new scale of fees is that no fee is paid in respect of the first mile. It is understood that the new scale came into operation on March 1st, 1921. The Subcommittee has considered this reply and is of opinion that the matter cannot usefully be pressed further.

PAYING PATIENTS IN POOR LAW INFIRMARIES.

POLICY OF THE MINISTRY OF HEALTH.

THE following communication from the Ministry of Health has been received by the Medical Secretary of the British Medical Association:

Ministry of Health, Whitehall, S.W.1,
April 2nd, 1921.

Sir,

I am directed by the Minister of Health to refer to Dr. Anderson's letter of the 5th ult. and the previous correspondence respecting the schemes in contemplation by the guardians of the Manchester and West Derby Unions for the admission of persons other than the sick poor to their institutions, and to state that, following upon the inquiries which have been made on the subject, the Minister has addressed to

each board of guardians a letter in the terms of that to the West Derby guardians, a copy of which is enclosed for the information of the British Medical Association.

I am, Sir, your obedient servant,
(Signed) H. H. TURNER.

The letter referred to in the above communication is as follows:

Ministry of Health, March 29th, 1921.

Sir,

The Minister of Health has given further consideration to the scheme described in your letter of the 28th ultimo for admitting paying patients to vacant beds in the guardians' institutions, and he has directed me to request you to lay before the guardians the following observations in regard to this scheme.

1. The Minister deplors the conditions which have arisen in Liverpool and elsewhere as a result of the shortage of hospital accommodation, and in his opinion the only solution of the problem which is likely to command general approval is to make the institutions at present controlled by the guardians available for the use of the community as a whole, but free from the restrictions and disabilities that are inseparable from the use of these institutions so long as they remain under the control of the Poor Law authorities.

2. At the same time the Minister recognizes that the scheme of the guardians is a sincere attempt to meet a grave need, and pending the complete reorganization of the health services of the country which the Government have in view, he would be most reluctant to place any obstacles in the way of any practical proposals which the guardians can bring forward as a temporary measure for alleviating the suffering caused by the shortage of hospital accommodation, and which it is within their legal competence to carry into effect.

3. The Minister feels bound, however, to inform the guardians that he is advised that there is no legal authority under which they are empowered:

(a) To hold themselves out as prepared to receive patients, without investigation of their circumstances, in consideration of an undertaking to pay a fixed weekly sum;

(b) To recover from or in respect of a patient a sum in excess of the actual cost of the relief given, or, on the other hand, to compound for the recovery of a fixed sum less than the actual cost of relief where the patient's means are sufficient to enable him to repay the whole of that cost; or

(c) To differentiate between patients as regards the accommodation provided for them, or as regards their treatment, nursing, dietary, etc., merely on the ground that repayment is being obtained.

4. Apart from the legal issues above mentioned, the Minister considers that in order to secure the fullest benefit consistent with reasonable economy from the operation of the scheme, it is essential that it should be carefully co-ordinated with other agencies for the provision of medical treatment; and with this object the local medical committee, if appointed, or other appointed representatives of the medical profession and the managers of the voluntary hospitals in the locality should be called by the guardians into consultation with them.

Among matters which might usefully form the subject of such consultation would be the kinds of cases, medically, that would be most suitable for admission, and amongst these the kinds, if any, as to which it is considered that on medical grounds priority might advisedly be given, and the kind of recommendation—for example, from a medical practitioner already in attendance, or from a hospital or other medical institution—which should be regarded as affording *prima facie* ground for admission. Other questions meriting consideration might be whether, in order to avoid waste from overlapping, any kind of division of function could be arranged between large general hospitals on the one hand and the guardians' infirmary on the other, and whether arrangements could be made whereby the medical teaching staff of the university could have access to the guardians' infirmary for purposes of medical education.

I am, Sir, your obedient servant,
(Signed) H. W. S. FRANCIS,
Assistant Secretary.

Association Notices.

SCHOLARSHIPS AND GRANTS IN AID OF SCIENTIFIC RESEARCH.

SCHOLARSHIPS.

THE Council of the British Medical Association is prepared to receive applications for Research Scholarships as follows:

1. An ERNEST HART MEMORIAL SCHOLARSHIP, of the value of £200 per annum, for the study of some subject in the department of State Medicine.

2. THREE RESEARCH SCHOLARSHIPS, each of the value of £150 per annum, for research into some subject relating to the Causation, Prevention, or Treatment of Disease.

Each scholarship is tenable for one year, commencing on October 1st, 1921. A Scholar may be reappointed for not more than two additional terms.

The Conditions of the award of Scholarships are stated in the Regulations, a copy of which will be supplied on application to the Medical Secretary of the Association, 429, Strand, London, W.C.2.

GRANTS.

The Council of the British Medical Association is also prepared to receive applications for Grants for the assistance of Research into the Causation, Treatment, or Prevention of Disease. Preference will be given, other things being equal, to members of the medical profession, and to applicants who propose as subjects of investigation problems directly related to practical medicine.

The Conditions of the award of Grants are stated in the Regulations, a copy of which will be supplied on application to the Medical Secretary of the Association, 429, Strand, London, W.C.2.

Applications.

Applications for Scholarships and Grants for the year 1921-22 must be made not later than Saturday, June 25th, 1921, in the prescribed form, a copy of which will be supplied by the Medical Secretary on application.

Each application should be accompanied by testimonials, including a recommendation from the head of the laboratory, if any, in which the applicant proposes to work, setting out the fitness of the candidate to conduct such work, and the probable value of the work to be undertaken. This is not intended, however, to prevent applications for Grants in aid of work which need not be performed in a recognized laboratory.

ELECTION OF COUNCIL OF ASSOCIATION, 1921-22.

A LIST of the Groups of Branches in the United Kingdom for election of twenty-four Members of the Council, 1921-22, and **Nomination Form**, were published in the SUPPLEMENT of March 12th (p. 73). The **Nominations** must be in the hands of the Medical Secretary **by May 16th**.

The result of the election for Members of Council by the Groups of the Oversea Branches was published in the SUPPLEMENT of February 19th, 1921.

ELECTION OF REPRESENTATIVE BODY OF ASSOCIATION, 1921-22.

Constituencies in Representative Body.

THE Council has finally grouped the **Home Divisions** for election of the Representative Body, 1921-22, in the same manner as for 1920-21, except that the Caithness and Sutherland Division of the Northern Counties of Scotland Branch, and the Rotherham and Sheffield Divisions of the Yorkshire Branch have been made independent Constituencies.

As intimated to all the **Oversea Bodies**, the Council has made each Oversea Division and Division-Branch an independent Constituency.

Election of Representatives and Deputy-Representatives.

THE REPRESENTATIVES AND DEPUTY-REPRESENTATIVES in the Representative Body *must be elected not later than June 17th*, and their names notified to the Medical Secretary **not later than June 24th**. The Annual Representative Meeting at Newcastle begins on July 15th.

Special attention is drawn to the fact that the election of Representative(s) and Deputy-Representative(s) may, at the discretion of the Constituency, be carried out by General Meeting of the Constituency, or by postal vote.

MOTIONS FOR ANNUAL REPRESENTATIVE MEETING, NEWCASTLE, JULY, 1921.

NOTICES OF MOTION by Divisions, Constituencies, or Branches, for the consideration of the Annual Representative Meeting of the Association, commencing Friday, July 15th, 1921, proposing to make any addition to, or any amendment, alteration, or repeal of, any Article or By-law, or to make any new Article or By-law, or proposing material alteration of the policy of the Association in matters relating to the honour and interests of the profession or of the Association, must be published in the BRITISH MEDICAL JOURNAL SUPPLEMENT not later than May 14th, and for this purpose should be received by the Medical Secretary **not later than April 30th**.

BRANCH AND DIVISION MEETINGS TO BE HELD.

SUSSEX BRANCH: HASTINGS DIVISION.—A meeting of the Division, to which all medical practitioners in East Sussex are invited, will be held at the Albany Hotel, Hastings, on Friday, April 15th, at 4 p.m. Dr. Alfred Cox, Medical Secretary British Medical Association, will give an address entitled "How much more State medical service does the medical profession want?" The chair will be taken by Dr. J. D. Hessey. The address will be followed by questions and a discussion, to be opened by Dr. E. W. Skinner, J.P.

Meetings of Branches and Divisions.

METROPOLITAN COUNTIES BRANCH: CITY DIVISION.

The City Division held a dinner-dance at the Abercorn Rooms, Great Eastern Hotel, Liverpool Street, on March 31st. Over fifty members and friends attended, and a most successful evening was spent. It is intended to hold another similar function in December.

INSURANCE.

CORRESPONDENCE.

Dental Anaesthetics: Insurance Records.

SIR,—It is evident that there are misapprehensions still to be removed in spite of all official communications and of memoranda from the Insurance Acts Committee sent to all Panel Committees and to every insurance practitioner. It is curious that some doctors prefer the greater trouble of writing to the lesser trouble of reading.

Dr. W. G. Bennett will be glad to know that he will not, as an insurance practitioner, be compelled to attend his patients at the surgeries of dentists who may be newly qualified under the Dental Bill if it becomes an Act. Indeed, as an insurance practitioner he is not in any way concerned with dental treatment by a dentist old or new. Such treatment is not within the insurance contract, and therefore fees for anaesthetics required for such treatment are a purely private matter, and are not allowed to be paid from the medical pool. If Dr. Bennett has been sending in claims for such anaesthetics his claims should have been disallowed by his Panel Committee.

Dr. Howard Murphy is concerned as to his course of action in order to keep his records when, as he imagines, the envelopes are "sent each year to the Insurance Committee for statistical tables to be drawn up." He will be relieved to know that they have not to be sent up each year or at any other time; and if he will read the official instructions he will see that the contingency of having to keep some notes with regard to a patient for whom he is not at the time in possession of an official envelope has not been overlooked, and that the course of action in this contingency is definitely laid down.

I do not think that Dr. Murphy's suggestion that two separate sets of records should be required will commend itself to insurance practitioners in general, but he does draw attention to several minor points which merit attention. May I emphasize the request of the Insurance Acts Committee that practitioners and Panel Committees will send up within the next six weeks any practical suggestions for the improvement of the present record forms or of the procedure to be adopted in connexion with them, so that all such suggestions may be codified and submitted to the next Panel Conference? This will be helpful, whereas such resolutions as those of the London Panel Committee—that records are necessary but that the present ones should be discontinued—are not helpful in the least. Perhaps they are not intended to be.—I am, etc.,

Stroud Green, N., April 2nd.

H. B. BRACKENBURY.

LOCAL MEDICAL AND PANEL COMMITTEES.

LONDON.

AT the last meeting of the London Panel Committee a report was presented by a deputation which waited recently on the Ministry of Health to discuss the question of surgery and waiting-room accommodation. The matter arose out of the action of the Insurance Committee in imposing a condition with respect to surgery accommodation upon practitioners who had applied for permission to include more than 3,000 insured persons on their lists. The representatives of the Ministry at the interview expressed the opinion that the question of surgery accommodation was a relevant circumstance in dealing with practitioners who had unusually large lists, and suggested that the Allocation Subcommittee, which is constituted partly of Insurance Committee representatives and Panel Committee representatives, was the proper body to deal in the first instance with all questions relating to surgery accommodation. This suggestion was agreed to, and the terms of reference of the

Allocation Subcommittee are to be widened accordingly. If a practitioner's accommodation appears to be inadequate for his practice, representations at first will be made to him, and in the event of his refusal to comply with a reasonable request, the matter will be brought to the notice of the Insurance Committee.

A scheme has been drafted for the reconstitution of the Panel Committee. The chief features of the proposals are that members of the committee should be elected for three years, one-third to retire annually; and that representation should be based on the number of electors in each area (one representative for each thirty or part of thirty in every borough). Under the present arrangements some boroughs are inadequately represented and others over-represented.

INSURANCE COMMITTEES.

LONDON.

THE London Insurance Committee, on March 31st, passed a resolution to the effect that unless steps were taken to keep the Committee notified of changes of address by insured persons, it would be unable to keep up to date the list of persons for whose treatment each insurance practitioner was responsible, as required by the Medical Benefit Regulations, and, further, that in view of the large number of inaccuracies in the registers, due to the non-notification of changes of address, it was impracticable properly to carry out the clause of the allocation scheme relating to the assignment of insured persons to practitioners. A deputation is to bring the subject before the Minister of Health.

Lock-up Surgeries.—It was reported that the Minister of Health's attention had been drawn recently to cases, particularly in the East End of London, in which insurance practitioners resided at a considerable distance from their surgeries, and inadequate arrangements were made for the attendance of a deputy in the absence of the principal practitioner. The Committee was requested to investigate the matter. Inquiries have already proceeded in three boroughs, and a full report is to be made when the investigations are completed. The Minister stated that while the considerations applied with special force when a practitioner was continuously absent from his practice and did not attend at the surgery, mere attendance during the restricted surgery hours was not in itself a complete fulfilment of the obligation to give personal service if during the remainder of the day and night the practitioner was not within reasonable call.

Range of Medical Service.—The Local Medical Committee having decided that an operation for the removal of haemorrhoids and an operation for the removal of cysts in the neighbourhood of the knee-joint were not such as could be properly undertaken by a general practitioner of ordinary professional competence and skill, the Medical Benefit Subcommittee of the Insurance Committee challenged this finding, and recommended to the Insurance Committee that it should intimate to the Ministry of Health its non-concurrence with this limitation upon the duties to be expected from an insurance practitioner. Mr. P. Rockliffe urged that if it was true that certain insurance practitioners were not capable of performing these operations their capitation fee should be forfeited and given to the hospitals where the operations were in fact performed. After some discussion, in which the medical members protested against lay judgement in a professional matter, the chairman of the subcommittee took back the recommendation in order to enable his subcommittee to present it later in a more reasoned form. The opinion of the Local Medical Committee was arrived at on the grounds that an operation for haemorrhoids involved risk of both primary and secondary haemorrhage, and that the removal of cysts from the neighbourhood of the knee-joint involved perforation of the joint and consequent risk of sepsis.

Naval and Military Appointments.

ROYAL NAVAL MEDICAL SERVICE.

THE following appointments are announced by the Admiralty: Surgeon Commanders F. C. Wright to the *Lowestoft* for service on station as requisite; A. C. W. Newport, M.V.O., to the *President*, additional, for Cambridge University Naval School; D. G. Addison-Scott to the *Lowestoft* as Fleet Medical Officer on re-commissioning; C. H. L. Petch to the *Dragon*, W. H. Edgar to the *Wildfire*, A. R. Thomas, O.B.E., to the *Sandhurst*, G. Christie to the *Victory* additional for Haslar Hospital, J. H. Burdett to R.N. Hospital, Malta; Surgeon Lieutenant Commanders G. L. Ritchie, M.C., to the *Osea*, W. J. Gerrard to the *Surprise*; Surgeon Lieutenant G. Aubrey to the *Ajax*.

ARMY MEDICAL SERVICE.

ROYAL ARMY MEDICAL CORPS.

Lieut.-Colonel T. E. Fielding, D.S.O., relinquishes the acting rank of Colonel.
Lieut.-Colonel A. R. O'Flaherty retires on retired pay.
Lieut.-Colonel N. Tyan-ke is placed on retired pay and is granted the rank of Colonel.
Major and Brevet Lieut.-Colonel F. W. Lamballe is placed on retired pay on account of ill health caused by military service.
Major W. Byam, O.B.E., relinquishes the temporary rank of Lieut.-Colonel on reduction of establishment.
Temporary Major E. H. Marshall (Major R.H. and R.F.A.T.F.) relinquishes his temporary commission.
Captain R. G. Shaw, M.C., to be acting Major from November 21st, 1919, to June 4th, 1920.

Captain A. B. H. Bridges, O.B.E., is restored to the establishment. To be Captains: Temporary Captain A. S. Plant, M.C., with seniority, February 4th, 1918, and precedence next below R. C. Atchinson; Captain S. O. Dolan from R.A.M.C.(T.F.), with seniority August 16th, 1918, and precedence next below C. F. Anthonisz; Captain F. McKibbin, from R.A.M.C.(S.I.), with seniority September 25th, 1918, and precedence next below P. A. L'Estrange.

F. J. Scrimgeour, O.B.E., relinquishes the local rank of Major, July 10th, 1919 (substituted for notification in the *London Gazette*, November 22nd, 1920).

Temporary Lieutenant H. P. Hodge to be temporary Captain.

The following relinquish their commissions: Temporary Lieutenant-Colonel and retain the rank of Lieutenant-Colonel: P. C. E. Tribe, O.B.E., Ernest W. White. Temporary Captains and retain the rank of Captain: C. L. de Zylva, on ceasing to serve with the Ceylon Sanitary Company; P. Kitchin, A. Cowes, Arthur G. Leitch.

ROYAL AIR FORCE. MEDICAL BRANCH.

The following are granted temporary commissions in the ranks stated, with effect from and with seniority of the dates indicated: Flight Lieutenants C. W. T. Baldwin (March 24th), D. Le Bas and W. R. Reith (April 1st), Flying Officers: F. T. Allen (March 29th), J. A. Perdrau (April 1st).

INDIAN MEDICAL SERVICE.

Lieut.-Colonel W. R. Battye, D.S.O., has been posted as Administrative Medical Officer in Central India and Agency Surgeon, Southern States of Central India.

Major G. D. Franklin, O.B.E., has been posted as Residency Surgeon, Madore.

Colonel T. Stodart, M.B., has been permitted to retire from the service (January 13th, 1921).

Major-General W. R. Edwards, C.R., C.M.G., K.H.P., Director-General, has been granted privilege leave for six months, March 15th, 1921.

Major-General W. H. B. Robinson, C.R., Surgeon-General with the Government of Bengal, has been appointed to officiate as Director-General, with effect from the date on which he assumes charge of that office.

Lieut.-Colonel W. H. Dickinson, Officiating Chemical Examiner, Bengal, and Professor of Chemistry, Medical College, Calcutta, has been granted, with effect from February 1st, combined leave for twelve months.

Colonel J. Garvie, K.H.S., Inspector-General of Civil Hospitals and Prisons, Assam, has been granted, with effect from March 20th, combined leave for eight months.

Lieut.-Colonel B. H. Deava, Principal and Professor of Medicine, Medical College, Calcutta, and First Physician to the College Hospitals, has been appointed to officiate as Inspector-General of Civil Hospitals and Prisons, Assam.

The services of Captain C. Newcombe, M.B., have been placed permanently at the disposal of the Government of Madras (December 4th, 1920).

Major R. T. D. MacGregor, Medical Officer, His Britannic Majesty's Consulate for Sistan and Kalin, is appointed to officiate as His Britannic Majesty's Consul for Sistan and Kalin in addition to his own duties (January 17th).

Lieut.-Colonel F. A. Smith has been posted as Residency Surgeon at Hyderabad (February 1st).

The undermentioned officers have been permitted to retire from the service, with effect from the dates specified: Colonel W. M. Molesworth, C.I.E., C.B.E., V.B.S. (January 22nd), Lieut.-Colonels C. Doochan and J. M. Crawford, O.B.E. (February 1st), Lieut.-Colonel W. B. Lane, C.I.E., C.B.E. (February 8th).

Major R. B. Seymour Sewell, Surgeon-Naturalist Marine Survey of India, has been granted, with effect from September 1st, 1920, thirteen months' combined leave.

Colonel C. R. M. Green, Inspector-General of Civil Hospitals, Central Provinces, has been granted privilege leave from February 25th.

Lieut.-Colonel P. F. Chapman, C.I.E., Civil Surgeon, Nagpur, has been appointed to officiate as Inspector-General of Civil Hospitals, Central Provinces, with effect from the date on which he assumes charge of his duties.

Lieut.-Colonel F. O'Kinealy, C.I.E., Surgeon-Superintendent General Hospital, Calcutta, has been appointed to officiate as Surgeon-General with the Government of Bengal (March 15th).

Major (Brevet Lieut.-Colonel) F. P. Connor, D.S.O., Professor of Clinical and Operative Surgery, Medical College, Calcutta, and Surgeon to the College Hospital, has been granted, with effect from February 21st, combined leave for eight months.

Major H. R. Steen, M.D., has been appointed to act as Professor of Clinical and Operative Surgery, Medical College, Calcutta, and Surgeon to the College Hospital (February 21st).

TERRITORIAL FORCE.

ROYAL ARMY MEDICAL CORPS.

Lieut. Colonel H. J. de Legh, T.D., resigns his commission and retains the rank of Lieutenant-Colonel, with permission to wear the prescribed uniform.

Captain H. J. G. Wells, R.A.M.C., to be Adjutant of the R.A.M.C. School of Instruction, West Riding Division.

Captain R. Ellis resigns his commission, and is granted the rank of Major.

Captain A. M. Daillie resigns his commission and retains the rank of Captain.

Captains to be Majors: S. F. St. J. Steadman, H. K. Griffith.

Captain J. G. Cooke resigns his commission, and is granted the rank of Major.

Captain D. R. E. Roberts (late R.A.M.C.) to be Captain, with precedence as from April 10th, 1918.

Lieutenant J. F. O'Grady to be Captain.

J. A. L. Loudon to be Lieutenant.

2nd London Sanitary Company.—Captain F. S. Carson, M.C., resigns his commission and retains the rank of Captain.

5th Southern General Hospital.—Captain C. H. Cowen resigns his commission and is granted the rank of Major.

Supernumery for Service with the O.T.C.—Captain H. Emerson, M.C., to be Major.

Sanitary Service.—Major R. A. Farrar is restored to the establishment on ceasing to be employed under the Colonial Office.

DIARY OF SOCIETIES AND LECTURES.

- HARVEIAN SOCIETY,** Town Hall, Paddington Green, W.—Thurs., 8.30 p.m., Mr. D. C. L. Fitzwilliams, C.M.G.: Naevi of Children and their Treatment.
- HUNTERIAN SOCIETY,** Sion College, Embankment, E.C.—Wed., 9 p.m., Discussion on the Treatment of Syphilis. To be opened by Mr. J. E. R. McDonagh.
- ROYAL COLLEGE OF PHYSICIANS OF LONDON,** Pall Mall East, S.W.—Tues. and Thurs., 5 p.m., Oliver Sharpey Lectures by Dr. Thomas Lewis, C.B.E., F.R.S.: Observations upon the Nature of Auricular Flutter and Fibrillation.
- ROYAL SOCIETY OF MEDICINE,**—Mon., 5 p.m., Demonstration of Lantern Slides in natural colours of dermatological and other medical subjects. Tues., 5 p.m., General Meeting of Fellows. *War Section:* Mon., 5.30 p.m., Surgeon-Commander S. F. Dudley, R.N.: Influenza Epidemic in the Royal Navy. *Section of Surgery, Subsection of Proctology:* Wed., 5 p.m., Discussion on Pruritus Ani, to be opened by Mr. Lockhart-Mummery and Sir Charles Gordon-Watson. *Section of Otolology:* Leicester Infirmary, Sat., 2.30 p.m., Mr. T. B. Layton and Mr. A. Ryland: Quantitative Estimation of Hearing; Unilateral Deafness. Mr. F. J. Clemenson: Sinusitis in Children. Cases will be shown by Dr. Macleod and Mr. Kece. Demonstration at the Aural Clinic of the Leicester Education Committee.
- ST. JOHN'S HOSPITAL,** 49, Leicester Square, W.C.—Thurs., 6 p.m., Chesterfield Lecture by Dr. W. Griffith: Treatment of Skin Diseases.
- SOCIETY FOR THE STUDY OF INEBRIETY,** 11, Chandos Street, W.1.—Thurs., 4 p.m., Discussion on the Use of Alcohol in Medicine. To be introduced by Dr. H. H. Dale, C.B.E., F.R.S.

British Medical Association.

OFFICES AND LIBRARY, 419, STRAND, LONDON, W.C.2.

Reference and Lending Library.

- THE READING ROOM,** in which books of reference, periodical and standard works can be consulted, is open to member from 10 a.m. to 6.30 p.m., Saturdays 10 to 2.
- LENDING LIBRARY:** Members are entitled to borrow books including current medical works; they will be forwarded if desired, on application to the Librarian, accompanied by 1s. for each volume for postage and packing.

Departments.

SUBSCRIPTIONS AND ADVERTISEMENTS (Financial Secretary and Business Manager, Telegrams: Articulate, Westrand, London).
MEDICAL SECRETARY (Telegrams: Medisecra, Westrand, London).
EDITOR, British Medical Journal (Telegrams: Aitiology, Westrand, London).

Telephone number for all Departments: Gerrard 2630 (3 lines).

SCOTTISH MEDICAL SECRETARY: 6, Rutland Square, Edinburgh (Telegrams: Associate, Edinburgh. Tel.: 4351 Central.)

IRISH MEDICAL SECRETARY: 16, South Frederick Street, Dublin (Telegrams: Facillus, Dublin. Tel.: 4737 Dublin.)

Diary of the Association.

APRIL.

- 15 Fri. London: Standing Subcommittee of Central Ethical Committee, 2.30 p.m.
Hastings Division, Albany Hotel, Hastings, 4 p.m.: Address by Dr. Alfred Cox on "How much more State medical service does the profession want?"
- 20 Wed. London: **Council**, 10 a.m.

POST-GRADUATE COURSES AND LECTURES.

GLASGOW POST-GRADUATE MEDICAL ASSOCIATION, Eye Infirmary, Wed., 4.15 p.m., Eye Cases.

MANCHESTER ROYAL INFIRMARY,—Tues., 4.30 p.m., Mr. F. H. Westmacott: Suppuration in the Accessory Cavities of the Nose.

WEST LONDON POST-GRADUATE COLLEGE, Hammersmith, W.—Daily, 10 a.m. (and 2.30 p.m. Tues), Ward Visits; 2 p.m., In- and Out-patient Clinics and Operations.

APPOINTMENTS.

BERRY, William A., M.D., D.P.H., Medical Officer of Health for the City of Bloemfontein, O.F.S.

BROWNLE, W. Barrie, M.D., Glas., F.R.C.S.E., Ophthalmic Specialist to County Court Circuit No. 4.

MILTON, J. Penn, M.R.C.S., L.R.C.P. Lond., Medical Superintendent to the Darvell Hall Sanatorium of the East Sussex County Council.

RIDDEL, James W. G. H., M.C., M.B., Ch.B., F.R.C.S. Edin., Major R.A.M.C. (R. of O.), Assistant Surgeon, South Devon and East Cornwall Hospital, Plymouth.

ROBINSON, William, M.B., Ch.B.: Leeds, Superintendent of the Brentwood Mental Hospital.

YOUNG, Gavin, M.C., M.B., Ch.B., Glas., F.R.F.P.S.G., Assistant Surgeon to the Throat and Nose Department, Western Infirmary of Glasgow.

BIRTHS, MARRIAGES, AND DEATHS.

The charge for inserting announcements of Births, Marriages, and Deaths is 9s., which sum should be forwarded with the notice not later than the first post on Tuesday morning, in order to ensure insertion in the current issue.

BIRTH.

WILLIAMS—On the 30th March, at Wednesfield, to F. S. Williams M.B., B.S. Lond., and Mrs. Williams—a son.

SUPPLEMENT

TO THE

BRITISH MEDICAL JOURNAL.

LONDON: SATURDAY, APRIL 16TH, 1921.

CONTENTS.

BRITISH MEDICAL ASSOCIATION.	PAGE	INSURANCE.	PAGE
CURRENT NOTES:		EMERGENCY TREATMENT AND ANAESTHETISTS' FEES: Circular Letter to Insurance and Panel Committees...	
MEMBERSHIP OF THE ASSOCIATION	97	99
ANNUAL REPORTS OF DIVISIONS AND BRANCHES	97	NAVAL AND MILITARY APPOINTMENTS ..	100
EMERGENCY TREATMENT BY INSURANCE PRACTITIONERS	97	DIARY OF SOCIETIES AND LECTURES	100
ANAESTHETISTS' FEES IN INSURANCE PRACTICE	97	ASSOCIATION INTELLIGENCE	100
DISPENSING IN RURAL AREAS	97	DIARY OF THE ASSOCIATION	100
ANNUAL MEETING AT NEWCASTLE: Hotel Accommodation	97	APPOINTMENTS... ..	100
ASSOCIATION NOTICES:		BIRTHS, MARRIAGES, AND DEATHS	100
MEETING OF COUNCIL	98		
MEETINGS OF BRANCHES AND DIVISIONS	98		

British Medical Association.

CURRENT NOTES.

Membership of the Association.

In the period January 1st to March 31st, 962 new members joined the British Medical Association. The accession of new members to the Association thus continues to show a steady increase, a fact which is all the more gratifying having regard to the increased subscription.

Annual Reports of Divisions and Branches.

The number of annual reports received for 1920 by the Council from Divisions and Branches shows a marked increase on those received for several years past. There are still, however, some Divisions and Branches which have not reported. The reports are of great help to the Council, and it is hoped that those bodies which have not yet sent their reports will do so as soon as possible.

Emergency Treatment by Insurance Practitioners.

The last Conference of Panel Committees passed the following resolution:

That in the opinion of this Conference the ruling by which an insured person requiring emergency treatment outside the area in which his insurance practitioner resides is regarded as a temporary resident is inequitable in its operation and liable to grave abuse and should be amended.

The Insurance Acts Committee, after discussing the whole matter, proposed to the Ministry of Health that in all cases in which the emergency happens outside the district in which the patient's own doctor has undertaken to give attendance, it should be paid for on an attendance basis out of the area pool of the patient's home area. It was pointed out by the Ministry that this proposal would be, from an administrative point of view, practically unworkable, and therefore the Insurance Acts Committee agreed to accept the new arrangement which is contained in the circular letter to Insurance and Panel Committees printed in full at page 99 of this week's SUPPLEMENT.

Anaesthetists' Fees in Insurance Practice.

As considerable differences of opinion appeared to exist not only in the minds of insurance practitioners but in the decisions made from time to time by Panel Committees with regard to the payment of anaesthetists' fees, the Insurance Acts Committee reviewed the whole subject and

eventually discussed every aspect of it with representatives of the Ministry of Health. With the decisions which are now set out in the circular letter referred to above the Insurance Acts Committee is in entire agreement.

Dispensing in Rural Areas.

Representatives of the Rural Practitioners Subcommittee of the Insurance Acts Committee are at present discussing with the Ministry of Health amendments to the present Regulations as set out in Article 10 (2) in regard to dispensing in rural areas. The matter is one which concerns Insurance Committees, chemists and doctors, and a conference between representatives of these parties and the Ministry has already discussed the difficulties. It is hoped that before long a solution satisfactory to all will be found. An announcement may be expected shortly.

EIGHTY-NINTH ANNUAL MEETING

OF THE

British Medical Association.

NEWCASTLE-UPON-TYNE, 1921.

HOTEL ACCOMMODATION.

GREAT difficulty is being experienced in compiling a satisfactory list of hotel and lodging accommodation in Newcastle, owing to the small number of hotels in the town, and to the acute shortage of houses compelling large numbers of people to live in apartments.

A list of private addresses at which rooms may be engaged will be published early in May. In the meantime the Hotels and Lodgings Committee is issuing herewith particulars of hotels in and around Newcastle. As the hotel accommodation is very limited indeed, and is even now being taken up for as far ahead as July by their regular class of guests, members are strongly advised to make their bookings at once.

Many of the hotels included in the list given on page 98 are short distances out of Newcastle, and are specially suited for members who intend to make their visit coincide with their annual holiday. Details as to distance and train service are inserted, so that members may judge of their convenience in attending sectional meetings and evening functions. It is possible, of course, that the train services may be modified before the date of the meeting, and the hotel tariffs quoted are also liable to alteration. The prices quoted are for single persons per night.

ADVANCE LIST OF HOTELS.
NEWCASTLE-UPON-TYNE.

	Bed and Breakfast.	Lunch.	Dinner.
Central Station	11/6	4/-	7/6
Turk's Head	11/-	3/-	5/-
County	9/6	3/-	4/6
Douglas	12/6	3/6	6/-
Central Exchange	8/-	2/6	4/6
Tyne Temperance	9/-	—	—
Market	6/6	—	—
Clyde	8/-	—	—
Sun	8/-	3/-	—
Norfolk	8/-	3/-	—

Several of the above hotels, as indicated, do not give lunch or dinner. There are abundant restaurants in the town where such meals can be obtained, as also at the other hotels included in the list.

St. Margaret's	10/6	3/-	4/-
Imperial	10/6	3/-	5/-
Keensington	8/6	2/6	3/6
Osborne	10/6	3/6	5/-

These hotels are chiefly residential. They each expect to have a number of rooms available at the date of the meetings.

Teas can be had at all the hotels mentioned above, and some will quote terms which are inclusive for the day or week. Particulars could be obtained by application to the Manager. All these hotels are within a short distance of the Reception Room.

WHITLEY BAY.

Popular seaside resort; bathing, boating, etc. On coast, close to Tynemouth. Train service: journey, half an hour by electric train, every quarter or half hour. Late trains available till 11.45 p.m.

Waverley (10 double rooms available for dates of meeting)	9/-	3/-	4/-
Royal	12/6	4/-	5/-
Avenue	10/-	3/6	5/-
Esplanade (a number of rooms with twin beds. Only 2 single rooms, and 1 double room)	8/6	3/6	6/-

DURHAM.

Train service: 40 minutes slow; 20 minutes express. Morning trains convenient, and last train 10.50 p.m.

County: Bed and breakfast, 10/6; inclusive charge per day, £1 1s.
Three Tuns: Bed and breakfast, 9/-; inclusive charge per day, 17/6
Rose and Crown: Bed and breakfast, 8/-; inclusive charge per day, 16/-
Other meals can be obtained at the above hotels.

SOUTH SHIELDS.

Frequent train service. Journey, 34 minutes. Convenient trains. Last train, 11.45 p.m.

Golden Lion	8/6	3/6	4/6
Regent	8/6	2/6	5/-
Royal	10/6	4/-	5/-

SUNDERLAND.

Seaside resort. Golf, etc. Numerous and convenient trains. Journey, 22 minutes (express). Last train from Newcastle, 11.18 p.m.

Grand	8/6	3/-	4/-
Queen's	8/6	3/6	4/6
Roker	8/-	2/6	4/6
Park Hotel	8/6	4/6	4/6

HEXHAM.

Very beautiful old market town, abounding in natural and historical interest. Situated on the Tyne about twenty miles from Newcastle. Golf, etc. Convenient and frequent trains. Journey, 35 minutes express; 50 minutes slow. Last train 9.50 p.m.; 10.45 p.m. Thursdays only.

Hydropathic. Special terms for doctors attending the meetings, 12/- per day.

Royal	8/-	—	3/-
Abbey	8/6	(Inclusive charge per day, 14/-)	—

MORPETH.

Another fine old market town. Train service: Express 40 minutes. Convenient trains. Last train from Newcastle 8.55 p.m.; 10.52 p.m. Thursdays only.

George and Dragon }
Queen's Head } Terms on application.
New Phoenix }

CORBRIDGE.

A lovely residential spot in the beautiful Tyne valley, about five miles east of Hexham, and of great archaeological interest. Train service: Express 40 minutes. Convenient morning trains. Last train from Newcastle 9.50 p.m.; 10.45 p.m. Thursdays only.

Wheatshief } Tyuedale } Bed and breakfast, between 5/- and 7/5. Angel }

The hotels at Hexham, Morpeth, and Corbridge are on main roads to Newcastle, and would be very well suited for doctors bringing their cars with them. Many of the hotels quote reduced figures for double rooms when shared by two people. Inquiry should be made about this when engaging rooms.

The Chairman of the Hotels and Lodgings Committee is Dr. H. KERR, O.B.E., and the Honorary Secretary, Dr. E. F. MURRAY, 52, Jesmond Road, Newcastle-upon-Tyne. (Telephone: 916 Jesmond.)

Association Notices.

MEETING OF COUNCIL.

The next meeting of Council will be held on Wednesday, April 20th, in the Council Room, 429, Strand, London, W.C.2, at 10 a.m., and will adjourn at 5 p.m. till 10 a.m. on Thursday, April 21st.

AN EALING DIVISION.

THE following change has been made by the Council, and takes effect on April 16th:

That an Ealing Division be formed, of area co-terminous with the district comprised in the Municipal Borough of Ealing, the Urban Districts of Acton, Brentford, Chiswick, Greenford, Hanwell, Hayes, Sonthall-Norwood, the new Division to form part of the Metropolitan Counties Branch, and the area of the South Middlesex Division to be modified accordingly.

Representation in Representative Body.—As may be decided by the Council.

BRANCH AND DIVISION MEETINGS TO BE HELD.

METROPOLITAN COUNTIES BRANCH: SOUTH-WEST ESSEX DIVISION.—The annual meeting and dinner of the Division will be held on Thursday, May 19th.

SUSSEX BRANCH: HASTINGS DIVISION.—A meeting of the Division, to which all medical practitioners in East Sussex are invited, will be held at the Albany Hotel, Hastings, on Friday, April 15th, at 4 p.m. Dr. Alfred Cox, Medical Secretary British Medical Association, will give an address entitled "How much more State medical service does the medical profession want?" The chair will be taken by Dr. J. D. Hessey. The address will be followed by questions and a discussion, to be opened by Dr. E. W. Skinner, J.P.

Meetings of Branches and Divisions.

MIDLAND BRANCH: CHESTERFIELD DIVISION.

THE annual report for the year 1920 was presented to the annual meeting of the Division held on March 11th. The outstanding feature of the year was the negotiation with the colliery field clubs for increased remuneration and the establishment of a system of "free choice of doctor." Up to the middle of the summer the discussion with the Field Club representatives was proceeding satisfactorily; at that period the medical officers to two of the largest clubs were induced to make private arrangements with their respective committees, with the result that the collective negotiations were seriously embarrassed. In the long run, however, the Division executive was successful in obtaining a considerably higher rate of remuneration than had applied previously over the greater part of the area. A successful dinner was given by members of the Division to Dr. J. Court on the occasion of his knighthood, and to Dr. A. W. Shea on being awarded the Distinguished Service Order. The success of this dinner brought about a desire that one shall be held annually. During the year five Divisional meetings were held, with an average attendance of 10.5 out of a membership of 53, which the executive does not consider satisfactory. The executive met seven times, and there were fourteen special meetings, to most of which non-members were invited for the discussion of special business.

SOUTH MIDLAND BRANCH: BUCKINGHAMSHIRE DIVISION.

A MEETING of the Buckinghamshire Division was held on March 30th, at the Royal Bucks Hospital, Aylesbury, with Dr. KENNISH in the chair. After a discussion on motor car taxation, it was decided to send the following resolution to the Representative Meeting:

That in the case of a medical man having two cars, who uses only one at a time, the licence for the second car should be halved.

On the question of coroners' inquest fees it was unanimously resolved:

That an adequate travelling allowance be paid in connexion with attendance at a coroner's court, and that the fee for giving evidence should be two guineas, and for a post-mortem examination three guineas; also that these fees should apply to the staffs of hospitals.

It was also resolved:

That when medical men consider the salary paid by a public body is inadequate, statistics and full particulars of the work done should be submitted to the Division for their consideration with a view of obtaining the support of the whole profession.

SUFFOLK BRANCH: NORTH SUFFOLK DIVISION.

At a meeting of the North Suffolk Division, held on March 31st, the report of the Council on the question referred to Divisions as to the British Medical Association becoming in part a federation was considered. It was resolved by 8 votes to 2 that the Association should become a federation of medical bodies alone.

INSURANCE.

EMERGENCY TREATMENT AND ANAESTHETISTS' FEES.

THE following circular letter has been issued this week by the Ministry of Health to all Insurance and Panel Committees:

Emergency Treatment and Payment of Fees for the Provision of the Services of Anaesthetists.

Sir,

I am directed by the Minister of Health to state that he has been in communication with the representatives of insurance practitioners with regard to certain difficulties, which have arisen in connexion with these matters, as affecting the distribution of funds between insurance practitioners.

1. *Emergency Treatment.*

The Conference of Panel Committees, held in October of last year, passed the following resolution:

"That in the opinion of this Conference the ruling by which an insured person requiring emergency treatment outside the area in which his insurance practitioner resides is regarded as a temporary resident is inequitable in its operation and liable to grave abuse and should be amended."

It is understood that the difficulty contemplated by the resolution is mainly that which arises in the case of insured persons who, being on the list of a practitioner in their home area, leave their home daily to work in some other district and return to their place of residence in the evening.

Where in such cases a practitioner renders emergency treatment outside of the insured person's home area, the credit which he receives for such a person as a "temporary resident" creates, it is considered, an undue charge against the Practitioners' Fund, and the Department have accordingly prepared an additional model clause for inclusion in the Distribution schemes. The clause should be inserted as a proviso to paragraph 1 of Clause 4 of the Distribution Scheme (Form M.C.3) as follows:

"Provided that if an application for treatment is made by an insured person who is outside the radius of practice of the practitioner responsible for his treatment, and intends to remain outside the radius for less than twenty-four hours, the practitioner providing treatment will, instead of having the applicant placed on his list, be entitled to be paid as though the treatment had been given in an emergency under the last preceding clause, and the amount paid to the practitioner will be payable out of the Fund in the same manner and subject to the same conditions as payments made in respect of the administration of anaesthetics."

This will involve the insertion of the words "or under the proviso to Clause 4 of the Scheme" after the word "anaesthetics" in the second line of Clause 8 of the Scheme.

It will be seen that the effect of this amendment will be to make these payments a charge on the Practitioners' Fund for the area in which treatment is given. If, in any area, these charges on the Fund appear to the Committee to be unduly high compared with other areas, it will be open to the Committee to submit a case for consideration to the Distribution Committee appointed under Article 20 of the Regulations.

If the Committee, after consultation with the Panel Committee, desire to amend the Distribution scheme in this manner, the Department would be prepared to approve the amendment, and approval is hereby given to the adoption of the clause set out above. If it is decided to amend the Scheme, the Department should be informed, and the necessary notice sent to practitioners under agreement with the Committee.

2. *Anaesthetists' Fees.*

It has been found, as a result of recent correspondence with committees, that the power of Panel Committees under Clause 2 of the Distribution Scheme to scrutinize and disallow claims for the payment of anaesthetists' fees has resulted in a number of such claims being disallowed on the ground that the operation or service in connexion with which the anaesthetic was administered was outside the scope of medical benefit.

While it is open to the Panel Committee to raise such a question for determination in the manner prescribed by Article 35 of the Regulations, it is clearly undesirable that there should be any general action which should tend to an undue narrowing of the view taken by practitioners of their obligations under the terms of service.

It has been agreed that it would be of assistance if a model form were issued for use by practitioners claiming

fees for the services of anaesthetists, and the enclosed model form (G.P. 19) has accordingly been prepared for this purpose. It will be observed that the form contains a declaration to be signed by the practitioner claiming the fee to the effect that no charge was made by him for the operation or other service in connexion with which the anaesthetic was administered which he regarded as within his obligations as an insurance practitioner.

It is hoped that this declaration will obviate the necessity for the raising of any questions under Article 35 in connexion with cases in which an anaesthetist's fee is claimed.

It is desirable that this form should be generally adopted, and where this is done it will be necessary to make provision in paragraph 2 of the Distribution Scheme that the accounts for anaesthetists' fees should be furnished by practitioners on the form provided for the purpose, which should be appended to the scheme.

If any form is proposed to be appended to the Distribution Scheme other than the enclosed model, it will be necessary to obtain the approval of the Department, but the model form and the alteration to Article 2 of the Distribution Scheme is hereby formally approved.

Discussion has also taken place with representatives of insurance practitioners in regard to certain special cases where doubt has been expressed as to whether anaesthetists' fees were payable. In view of the different circumstances of particular cases, and having regard to the fact that an appeal may be made against the disallowance of such fees, it is not possible for the Department to give any rulings which would be of universal application, but the following notes of cases may be taken as generally representing the view of the Department arrived at after the discussions above referred to:

(a) *Operations in Cottage Hospitals and Similar Institutions.*—The question whether a fee should be allowed for the services of an anaesthetist where the operation is performed in hospital is a matter for the Panel Committee to determine. It is considered in general that if the staff of the hospital is a selected staff no anaesthetist's fee should be allowed, but if the hospital is one where any general practitioner can treat his own patient, the fact that the operation was performed in a hospital would not necessitate disallowance of the fee, provided that the service in connexion with which the anaesthetic was administered was within the scope of medical benefit.

(b) *Anaesthetics Administered by Assistants and Partners.*—It is considered that in general anaesthetists' fees should be payable in cases where an insurance practitioner performs the operation and the anaesthetic is administered by his assistant or partner. Similarly, the fee would be payable where the practitioner responsible for the case administers the anaesthetic and the assistant or partner performs the operation.

(c) *Arrangements under Article 10 (1) of the Terms of Service.*—If a practitioner arranges with another practitioner under Article 10 (1) of the Terms of Service to perform the operation, and the anaesthetic is administered by the practitioner himself or his assistant or by another practitioner, it is considered that the fee would be payable.

(d) *Anaesthetics Administered in Connexion with the Extraction of Teeth, or in Connexion with an Operation Performed by a Specialist.*—Where the extraction is performed by a dentist no fee would be payable. In the comparatively rare cases where teeth are extracted by an insurance practitioner as part of his agreement—for example, in rural areas where this service is customarily undertaken by doctors—a fee would be chargeable against the Practitioners' Fund.

No fee would be payable in respect of anaesthetics administered in connexion with an operation performed by a specialist, as the operation itself would be outside the scope of medical benefit. It is also clear that where an insurance practitioner performs the operation and also administers the anaesthetic no fee would be payable.

I am to add that Regulations are at present under consideration to amend Article 10 (2) of the present Regulations in regard to dispensing in rural areas, of which formal notice to all practitioners will be necessary, and if the Committee decide to adopt the amendments to the Distribution Scheme indicated above, they may find it convenient to defer giving notice of the alterations to practitioners until they are in a position to include in the same communication a notice of the proposed amendment of Article 10 (2).

A further communication will be addressed to Committees on this matter as soon as possible.

I am, Sir,

Your obedient servant,

R. W. HARRIS.

FORM G.P. 19.

Form for Use under Art. 2 of the Distribution Scheme M.C./3.

To the Insurance Committee for the County of
Borough of

I hereby give notice that on [date] I rendered to the patient named below, who is included in my list, the professional service, particulars of which are appended hereto, which required the services of a second practitioner for the purpose of administering an anaesthetic.

I hereby declare that the service was undertaken by me without charge to the patient, as being within my obligation under my terms of service.

And I hereby claim the payment of the fee provided for in the Distribution Scheme.

Name of insured person
Society and Branch
Membership No.
Address

Name of practitioner administering anaesthetic—
.....

Place where operation was performed—
.....

Particulars of service rendered. (Here describe shortly the nature of the operation or other service.)

Signature

Date

NOTE.—This form must be forwarded to the Insurance Committee within seven days after the date on which the service was rendered.

Naval and Military Appointments.

ROYAL NAVAL MEDICAL SERVICE.

THE following appointments are announced by the Admiralty: Surgeon Commanders J. W. Craig to the *Conqueror* as Squadron Medical Officer; J. H. Lightfoot to the *Orion*; A. T. Rivers and G. D. Bateman to the *President*, additional (temporary), for service with the Medical Director; H. C. Whiteside to R.N. Sick Quarters, Dartmouth.

Surgeon Lieutenant Commander E. B. Fletcher, O.B.E., has been promoted to the rank of Surgeon Commander (D) and appointed to the *President*, additional, as Assistant to M.D.G. Surgeon Lieutenant J. B. Crawford has been promoted to the rank of Surgeon Lieutenant Commander.

ARMY MEDICAL SERVICE.

ROYAL ARMY MEDICAL CORPS.

Captain and Brevet Major J. D. Kidd, O.B.E., M.C., relinquishes the acting rank of Major, January 6th, 1921 (substituted for notice in the *London Gazette*, March 9th, 1921).

The following temporary Captains relinquish their commissions and retain the rank of Captain: L. J. Maxwell, J. A. Martin, R. H. Balfour-Barrow, P. G. Simpson, D. Evans, T. L. Davies, D. C. Snelzer, H. P. W. Lincoln, W. Pritchard-Airey, J. H. Whiteside.

ROYAL AIR FORCE.

MEDICAL BRANCH.

A. F. Wright is granted a temporary commission as Flight Lieutenant with effect from, and with seniority of, March 22nd.

The following relinquish their temporary commissions on return to naval duty: Wing Commander G. D. Bateman, O.B.E. (Surgeon Commander, R.N.), Squadron Leader A. R. Sharrod (Surgeon Lieutenant Commander, R.N.).

TERRITORIAL FORCE.

ROYAL ARMY MEDICAL CORPS.

Major W. A. Thompson to be Lieut.-Colonel and command 3rd Northern Field Ambulance.

Captain G. C. E. Simpson, O.B.E., to be Lieut.-Colonel and command 2nd West Lancashire Field Ambulance.

Captain L. T. Challinor vacates the appointment of D.A.D.M.S., 48th (South Midland) Division.

To be Majors:—Captains: L. A. Mackenzie, M.C., J. Turtle, S. J. Foulding, A. D. Kennedy, J. Taylor.

The following officers resign their commissions: Major (Brevet Lieut.-Colonel) B. M. H. Rogers, and is granted the rank of Lieut.-Colonel; Major W. R. N. Smithard, T.D., and is granted the rank of Lieut.-Colonel; Major L. T. Whelan, M.C. (February 25th, 1921), and retains the rank of Major (substituted for notification in the *London Gazette* of February 24th, 1921); Captain W. E. Kingdon, and retains the rank of Captain.

E. E. Pleasance (late Surgeon Sub-Lieutenant R.N.V.R.) to be Lieutenant.

DIARY OF SOCIETIES AND LECTURES.

ROYAL SOCIETY OF MEDICINE.—*Section of Therapeutics and Pharmacology*: Tues., 4.30 p.m., Annual General Meeting. Sir Leonard Rogers: Treatment of Leprosy and Tuberculosis with Sodium Glycinate. Dr. E. R. Walker: Quinine in the Treatment of Asiatic Cholera. *Section of Pathology*: Tues., 8.30 p.m., Annual General Meeting. Sir Lenthal Cheate: Parenchymatous Inflammation of Breast. Mr. A. T. Gleason, Miss K. Allen, and Dr. R. A. O'Brien: (1) Schick Reaction; (2) Diphtheria Prophylactic Immunization. Dr. E. H. Kelle and Dr. Joan Ross: Endotheliomata. *Section of History of Medicine*: Wed., 5 p.m., Dr. T. Wilson Parry: Psychiatric Trephined Skulls of Great Britain. Dr. F. G. Chandler: History of the Diagnosis and Treatment of Emphysema. *Section of Dermatology*: Thurs., 4.30 p.m., Cases. *Section of Study of Disease in Children*: Fri., 4.30 p.m., Cases. *Section of Epidemiology and State Medicine*: Fri., 8.30 p.m., Dr. W. M. Willoughby: Plague on Ships.

ROYAL COLLEGE OF SURGEONS, Lincoln's Inn Fields, W.C.—Mon., 5 p.m., Museum Demonstrations, Professor Shattock: Myoma, Chondroma. Fri., 5 p.m., Professor Keith: Microscopic Structure of the Colon in Health and Disease.

POST-GRADUATE COURSES AND LECTURES.

GLASGOW POST-GRADUATE MEDICAL ASSOCIATION, Victoria Infirmary, Wed., 4.15 p.m., Dr. W. H. Brown: Skin Cases.

LONDON LOCK HOSPITALS.—Clinics daily. Lectures: (at 91, Dean Street, W.), Mon., 2.30 p.m., Mr. Thomson: Gonorrhoea; 5 p.m., Mr. Gibbs: Posterior Urethritis; Tues., 2.30 p.m., Mr. McDonaga: Nervous Syphilis; 5 p.m., Mr. Juler: Venereal Diseases of the Eye; Wed., 4.30 p.m., Mr. Joly: Acute Gonorrhoea in the Male; Thurs., 4 p.m., Dr. Sidney Phillips: Syphilitic Affections of Liver; Friday, 2.30 p.m., Demonstration of Tests used in Gonorrhoea; 4 p.m., Mr. Abraham: Gonorrhoea in the Female. (At 283, Harrow Road) Mr. Ernest Lane: Venereal Disease in Women and Children.

MANCHESTER ROYAL INFIRMARY.—Thes., 4.30 p.m., Mr. J. P. Buckley: Lotussusception.

WEST LONDON POST-GRADUATE COLLEGE, Hammersmith, W.—Daily, 10 a.m. (and Wed., 1 p.m.), Ward Visits; 2 p.m., In- and Out-patient Clinics and Operations.

British Medical Association.

OFFICES AND LIBRARY, 419, STRAND, LONDON, W.C.2.

Reference and Lending Library.

THE READING ROOM, in which books of reference, periodicals, and standard works can be consulted, is open to members from 10 a.m. to 6.30 p.m., Saturdays 10 to 2.

LENDING LIBRARY: Members are entitled to borrow books, including current medical works; they will be forwarded, if desired, on application to the Librarian, accompanied by 1s. for each volume for postage and packing.

Departments.

SUBSCRIPTIONS AND ADVERTISEMENTS (Financial Secretary and Business Manager, Telegrams: Articulate, Westrand, London), MEDICAL SECRETARY (Telegrams: Medisecra, Westrand, London), EDITOR, *British Medical Journal* (Telegrams: Aitiology, Westrand, London).

Telephone number for all Departments: Gerrard 2630 (3 lines).

SCOTTISH MEDICAL SECRETARY: 6, Rutland Square, Edinburgh. (Telegrams: Associate, Edinburgh. Tel.: 4361 Central.)

IRISH MEDICAL SECRETARY: 16, South Frederick Street, Dublin. (Telegrams: Bacillus, Dublin. Tel.: 4737 Dublin.)

Diary of the Association.

APRIL.

15 Fri. London: Medico-Sociological Committee, 2.30 p.m.
London: Standing Subcommittee of Central Ethical Committee, 2.30 p.m.

Hastings Division, Albany Hotel, Hastings, 4 p.m.: Address by Dr. Alfred Cox on "How much more State medical service does the medical profession want?"

20 Wed. London: Council, 10 a.m. to 5 p.m.

21 Thurs. London: Council, 10 a.m.

MAY.

19 Thurs. South-West Essex Division: Annual Meeting and Dinner.

APPOINTMENTS.

GRIFFITHS, Alfred, M.B., C.M., F.R.C.S. Edin., Medical Referee under the Workmen's Compensation Act, 1906, for the Sheriffdom of Stirling, Dumbarton, and Clackmannan, and to be attached more particularly to the Falkirk district, vice A. D. Fraser, M.D.

HIRSCH, Charles T. W., Captain late R.A.M.C., M.R.C.S., L.R.C.P., Anaesthetist to the London Temperance Hospital.

ORR, John, O.B.E., M.B., C.M. Edin., Certifying Factory Surgeon for Eccles (Lancaster).

BIRTHS, MARRIAGES, AND DEATHS.

The charge for inserting announcements of Births, Marriages, and Deaths is 9s., which sum should be forwarded with the notice not later than the first post on Tuesday morning, in order to ensure insertion in the current issue.

MARRIAGES.

CORNELIUS-MATHER.—At Garrison Church, Colaba, Bombay, India, on March 19th, 1921, Captain W. H. Cornelius, R.A.M.C., eldest son of Mr. and Mrs. W. F. Cornelius, Teignmouth, to Dorothy, second daughter of Mr. and Mrs. A. Mather, Sefton Park, Liverpool.

DAVY-DECKITT.—On March 31st, 1921, at St. Paul's Church, Crew, by the Rev. J. Mellinsh, Hon. C.F., and the Rev. W. H. Brind, Richard Denis Davy, M.C., Captain R.A.M.C., son of the late Dr. Davy and of Mrs. Davy, of Hull, to Fanny, daughter of Mr. and Mrs. Duckitt, of Liverpool.

GRAHAM-BONNER.—On April 6th, in London, Norman B. Graham, M.C., B.A., M.B., D.P.M., of Purdysburn Villa Colony, Belfast, to Fannie Joan, third daughter of the late G. T. Bonner, Esq., and Mrs. Bonner, of Derby.

GRIFFITH-VISICK.—On April 11th, at Lyndhurst Road Church, Hampstead, by the Rev. Dr. R. H. Horton, John Richard Griffith, F.R.C.S. Eng., son of Arthur P. Griffith and Mrs. Griffith, of 59, Montpelier Road, Brighton, to Elsie Maud Visick, M.R.C.S., L.R.C.P., daughter of Dr. and Mrs. Hedley C. Visick, of 35, Rosslyn Hill, Hampstead.

DEATHS.

BARNES.—At 6, Portland Square, Carlisle, on the 12th inst., Henry Barnes, O.B.E., M.D., LL.D., aged 78.

CULLEN.—On March 29th, at Meerut, India, of pneumonia, William Harbour Cullen, Major Indian Medical Service, younger son of the late Deputy Surgeon-General David Cullen, A.M.D., and of Mrs. Cullen of Halsey House, Cheltenham, aged 40.

MINNS.—On April 6th, the result of a motor accident, Captain Allan Noel Minns, D.S.O., M.C., R.A.M.C., Alexandra House, Thetford, Norfolk.

SHEA.—On March 21st, at Carlton Dene, London Road, Ewell, Surrey, John Goodwin Shea, J.P., M.D., late of Chertfield, aged 65.

SUPPLEMENT

TO THE

BRITISH MEDICAL JOURNAL.

LONDON: SATURDAY, APRIL 23RD, 1921.

CONTENTS.

BRITISH MEDICAL ASSOCIATION.		PAGE	MEETINGS OF THE PROFESSION:		PAGE
CURRENT NOTES:			THE MEDICAL SECRETARY AT HASTINGS ...		105
THE ANNUAL MEETING AT NEWCASTLE ...	101	INSURANCE:			
MOTIONS FOR THE ANNUAL REPRESENTATIVE MEETING ...	101	CORRESPONDENCE ...		105	
TOUR OF YORKSHIRE DIVISIONS ...	101	LONDON PANEL COMMITTEE ...		105	
MEDICAL CINEMATOGRAPH EXHIBITION ...	101	NAVAL AND MILITARY APPOINTMENTS...		104	
ASSOCIATION NOTICES:			ASSOCIATION INTELLIGENCE ...		104
ELECTION OF COUNCIL AND REPRESENTATIVE BODY ...	102	DIARY OF SOCIETIES AND LECTURES ...		104	
MOTIONS FOR ANNUAL REPRESENTATIVE MEETING ...	102	APPOINTMENTS...		104	
BRANCH AND DIVISION MEETINGS TO BE HELD ...	102	BIRTHS, MARRIAGES, AND DEATHS ...		104	
MEETINGS OF BRANCHES AND DIVISIONS ...	102				

British Medical Association.

CURRENT NOTES.

The Annual Meeting at Newcastle.

THE arrangements are gradually going forward for the eighty-ninth Annual Meeting of the British Medical Association to be held next July at Newcastle-on-Tyne. The Association has twice before met in Newcastle; the first occasion was in 1870, with Dr. Edward Charlton as president, and the second in 1893, under the presidency of Sir George Hare Philipson. The proceedings will open this year on Friday morning, July 15th, when the Representative Body will begin its annual meeting, the session being continued on the three following weekdays. Council meetings have been provisionally fixed for the mornings of Monday, July 18th, and Wednesday, July 20th. The statutory annual general meeting will be held at 2 p.m. on Tuesday, July 19th, on which day the social and scientific business of the annual meeting will commence with the delivery by Professor David Drummond of his Presidential Address to the Association at 8 p.m. The sectional meetings for scientific and clinical work will be held, as usual, on the Wednesday, Thursday, and Friday; the mornings from 10 a.m. to 1 p.m. being given up to discussions, and the afternoons from 3 to 4.30 o'clock to clinical and laboratory demonstrations, of which a special feature will be made, as was the case at Cambridge last year. The list of sections and their presidents is printed below. The first five sections will meet on July 20th, 21st, and 22nd; the six following sections on two days each; and the remaining six sections on one day each.

Medicine: Professor Thomas Beattie.
Surgery: Professor J. Rutherford Morison.
Pathology and Bacteriology: Professor Stuart McDonald.
Preventive Medicine with Industrial Diseases: Sir Thomas Oliver.

Orthopaedics and Diseases in Children: Mr. A. H. Tabby.

Neurology and Psychiatry (July 20th and 21st): Professor A. W. Mackintosh.

Obstetrics and Gynaecology (July 21st and 22nd): Professor R. P. Ranken Lyle.

Ophthalmology (July 21st and 22nd): Professor J. D. Wardale.

Oto-Rhino-Laryngology (July 20th and 21st): Dr. G. William Hill.

Physiology, Pharmacology, Therapeutics, and Dietetics (July 20th and 21st): Dr. H. H. Dale.

Veneral Diseases (July 20th and 21st): Colonel L. W. Harrison.

Ambulance and Red Cross (July 20th): Sir James Cantlie.
Dermatology (July 21st): Dr. J. Farquhar Christie.

Medical Sociology (July 22nd): Sir Jenner Verrall.
Proctology (July 20th): Mr. J. P. Lockhart-Mummery.

Radiology and Electro-Therapeutics (July 22nd): Dr. Robert Knox.

Urology (July 22nd): Mr. J. W. Thomson Walker.

There will be religious services on Tuesday, July 19th, at 5 p.m. On Wednesday evening at 8 o'clock Sir Thomas Oliver will give an address on Industrial Diseases, and on the same day the Secretaries will hold their annual conference and dinner. The Annual Dinner of the Association will be held on Thursday evening, July 21st, and on Friday Professor Arthur Keith will deliver the Popular Lecture at 7.30 p.m. Saturday, July 23rd, the last day of the meeting, has been set apart for excursions to places of interest in the neighbourhood. Articles on the history, institutions, and industries of Newcastle have appeared in the JOURNAL of December 11th, 1920, March 12th and April 16th, 1921, and information about hotel accommodation was given in last week's SUPPLEMENT. The Honorary Local General Secretary is Mr. R. J. Willan (6, Kensington Terrace, Newcastle-on-Tyne).

Motions for the Annual Representative Meeting.

As will be seen in another column, motions of which two months' notice are required by the By-laws must be in the hands of the Medical Secretary by April 30th. Motions which do not propose any alterations of Articles or By-laws, nor any material alteration in the policy of the Association, are in order any time before the Annual Representative Meeting (which opens on July 15th at Newcastle), but the earlier they are received the greater publicity they will get. So far the only motions received which would involve any alteration in policy are one which suggests the formation of a "student class" of members with a reduced subscription, one proposing that the collective opinion of the profession can only be expressed by a body directly elected by the profession, and one suggesting that the Association should appoint representatives to the Federation of Medical and Allied Societies. Full notice of these and of all other motions received will be given in the SUPPLEMENT on or before May 14th. Those Divisions which have ideas for the improvement of the constitution, policy, or working arrangements of the Association are invited to formulate them and send them to the Medical Secretary.

Tour of Yorkshire Divisions.

The Medical Secretary has made arrangements to visit the following Divisions of the Yorkshire Branch during the last week in April:

Wednesday, April 27th, Leeds Division at Leeds, 5.30 p.m.
Wednesday, April 27th, Halifax Division at Halifax; evening meeting.
Thursday, April 28th, Barnsley Division at Barnsley, 4 p.m.
Thursday, April 28th, Huddersfield Division at Huddersfield; evening meeting.
Friday, April 29th, Scarborough Division at Scarborough, 8 p.m.

Medical Cinematograph Exhibition.

A cinematograph exhibition of medical and surgical films was held on March 30th, at Exeter, under the auspices of the Exeter Division of the British Medical Association.

The following films were exhibited: Cholecystectomy, appendicectomy, gastro-enterostomy, hysterectomy, undescended testes, tibial bone graft, wound sterilization (Carrel). Over 100 members attended, many coming from distant towns, and the greatest interest was shown in the demonstration.

Association Notices.

ELECTION OF COUNCIL OF ASSOCIATION, 1921-22.

A LIST of the Groups of Branches in the United Kingdom for election of twenty-four Members of the Council, 1921-22, and **Nomination Form**, were published in the SUPPLEMENT of March 12th (p. 73). The **Nominations** must be in the hands of the Medical Secretary **by May 16th**.

The result of the election for Members of Council by the Groups of the Oversea Branches was published in the SUPPLEMENT of February 19th, 1921.

ELECTION OF REPRESENTATIVE BODY OF ASSOCIATION, 1921-22.

Constituencies in Representative Body.

THE Council has finally grouped the **Home Divisions** for election of the Representative Body, 1921-22, in the same manner as for 1920-21, except that the Calthness and Sutherland Division of the Northern Counties of Scotland Branch, and the Rotherham and Sheffield Divisions of the Yorkshire Branch have been made independent Constituencies.

As intimated to all the **Oversea Bodies**, the Council has made each Oversea Division and Division-Branch an independent Constituency.

Election of Representatives and Deputy-Representatives.

THE REPRESENTATIVES AND DEPUTY-REPRESENTATIVES in the Representative Body *must be elected not later than June 17th*, and their names notified to the Medical Secretary **not later than June 24th**. The Annual Representative Meeting at Newcastle begins on July 15th.

Special attention is drawn to the fact that the election of Representative(s) and Deputy-Representative(s) may, at the discretion of the Constituency, be carried out by General Meeting of the Constituency, or by postal vote.

MOTIONS FOR ANNUAL REPRESENTATIVE MEETING, NEWCASTLE, JULY, 1921.

NOTICES OF MOTION by Divisions, Constituencies, or Branches, for the consideration of the Annual Representative Meeting of the Association, commencing Friday, July 15th, 1921, proposing to make any addition to, or any amendment, alteration, or repeal of, any Article or By-law, or to make any new Article or By-law, or proposing material alteration of the policy of the Association in matters relating to the honour and interests of the profession or of the Association, must be published in the BRITISH MEDICAL JOURNAL SUPPLEMENT not later than May 14th, and for this purpose should be received by the Medical Secretary **not later than April 30th**.

BRANCH AND DIVISION MEETINGS TO BE HELD.

METROPOLITAN COUNTIES BRANCH: CITY DIVISION.—A general meeting of the Division will be held at the Metropolitan Hospital to-day (Friday, April 22nd), at 9.15 p.m. Agenda: Election of officers for ensuing year. Representative for Annual Representative Meeting. Other matters.

METROPOLITAN COUNTIES BRANCH: LEWISHAM DIVISION.—A meeting of the Lewisham Division, to which all medical practitioners of Lewisham are invited, will be held at 45, Laurie Park Road, Sydenham, S.E.26, on April 26th, at 8.30 p.m., when the chair will be taken by Dr. G. W. Charsley. Agenda: Discussion of the Report of the Consultative Council (SUPPLEMENT, October 16th, 1920). Discussion re Municipal Clinics of Points in Letter from Honorary Secretary of Willesden Division in the BRITISH MEDICAL JOURNAL of January 29th, p. 171. Drs. Charsley and Gilchrist will report a case of pyaemia, and show specimens.

METROPOLITAN COUNTIES BRANCH: SOUTH-WEST ESSEX DIVISION.—The annual meeting and dinner of the Division will be held on Thursday, May 19th.

Meetings of Branches and Divisions.

EDINBURGH BRANCH: SOUTH-EASTERN COUNTIES DIVISION. A MEETING of the Division was held at Newtown St. Boswells on April 6th, when Dr. A. D. FLEMING, Chairman of the Division, presided.

The annual report and financial statement were presented and approved.

The report of the Council to Divisions and the Representative Body regarding the steps to be taken whereby the Association may become in part a federation was submitted, together with a circular on that subject from Dr. E. R. Fothergill. Dr. A. J. CAMPBELL referred to the desire of the authorities that there should be some body to represent authoritatively the views of the medical profession, and expressed the opinion that the public did not fully appreciate the extent to which the British Medical Association represented the profession.

After discussion, the following resolution was adopted:

That while this Division does not object to a federation of any bodies composed exclusively of medical practitioners, it objects to federation with bodies not consisting exclusively of registered medical persons.

The Scottish Consultative Council's Report having been issued to members was taken as read. The HONORARY SECRETARY submitted a resolution that had been passed by the Edinburgh Branch. The discussion opened with some remarks as to the exact meaning of various parts of the scheme, and particularly as regards the persons who would be entitled to benefit under it. Drs. MUIR, BLAIR, MCLAGAN, CULLEN, HENDERSON, and others contributed to the discussion. It was soon apparent that members considered that the scheme would entail financial liabilities far beyond anything that was likely to be met in the present state of public finances, and that it was only possible to discuss the various proposals on the assumption that the scheme would be financed irrespective of its cost. The questions asked by the Scottish Committee were generally answered in the affirmative, it being deemed that the majority of the proposals made in the scheme were in themselves desirable if they could be paid for. The questions answered in the negative were Nos. 4 and 13.

LANCASHIRE AND CHESHIRE BRANCH: ROCHDALE DIVISION.

THE annual meeting of the Rochdale Division was held at Rochdale on April 6th, when Dr. GEDDES was in the chair. The annual report showed that the membership had increased by three during the year; the average attendance at meetings was ten. The financial statement showed a small deficit.

The following officers were elected:

Chairman: Dr. Bateman. Vice-Chairman: Dr. Geddes. Secretary and Treasurer: Dr. James Melvin. Auditor: Dr. Harris. Representative in Representative Body and to Branch Council: Dr. S. T. Lord. Deputy Representative: Dr. James Melvin.

METROPOLITAN COUNTIES BRANCH (EAST HERTFORDSHIRE DIVISION).

A MEETING of the East Hertfordshire Division was held at the County Hospital, Hertford, on April 13th, when Dr. A. E. GILES (London) delivered a most instructive lecture on "Pessaries versus Operation in the Treatment of Displacements." Considerable discussion followed, in which most of those present took part.

SUFFOLK BRANCH.

THE spring meeting of the Suffolk Branch was held at Holesworth on April 13th, 1921. The following resolution was adopted:

That having in view the necessary financial difficulty of a small Division, the Branch Council asks the Organization Committee to consider some means of financing such Divisions providing the percentage of members is high.

Dr. CHARLES (Ipswich) showed an interesting series of pathological specimens. Dr. P. L. GIUSEPPI (Felixstowe) read a paper on some developments in the treatment of urethral strictures. Dr. WOOD (Woolpit) opened a discussion on thyroid therapy in private practice, and Dr. MITCHELL (Brookford) opened a discussion on the treatment of common colds and catarrhal conditions of the upper respiratory tracts.

UGANDA BRANCH.

THE annual meeting of the Uganda Branch was held at Mulago, Kampala, on January 15th, when Dr. Cook was in the chair.

The following officers were unanimously elected for 1921:

President: Major Wiggins, P.M.O. President-elect: Major Keane, D.S.O. Vice-President: Dr. Stanley Smith. Honorary Secretary and Treasurer: Captain Owen.

Dr. Peacock, who had been elected Honorary Treasurer and Secretary at a meeting held on July 22nd, 1920, was unable to act, as he had been transferred to an out-station. The Model Rules were accepted with slight modifications. It was agreed that no action should be taken with regard to modification of by-laws regarding adjudication of ethical cases (Articles of Association 10, b). It was noted with regret that Dr. J. A. Macdonald has been unable to visit Uganda. Major Wiggins, P.M.O., on behalf of the members, welcomed Dr. Cave, the only lady member in the country. Votes of thanks to the retiring President, Honorary Secretary, and other officers, and to Dr. Baker and Major Keane for entertaining the members at Mulago, were passed unanimously. A discussion on blackwater fever took place during the afternoon.

MEETINGS OF THE PROFESSION.

HASTINGS.

THE Medical Secretary addressed a meeting of the medical profession of Hastings and district at the Albany Hotel, Hastings, on Friday, April 15th. The meeting was called by Dr. A. M. Dady, Secretary of the Sussex Branch. There were fourteen present, Dr. J. D. HESSEY of St. Leonards being in the chair.

Dr. Cox said that his main object in attending the meeting was not so much to discuss the subject on which he had promised to address them but to find out whether the medical profession in Hastings and district was dead or only sleeping. There could be only two explanations of the prolonged disorganization of the medical profession in that district—either they were so well off that they had no grievances or they were unable to look far enough ahead to see that a local profession without proper organization was in a dangerous position.

He went on to deal with his subject, which was "How much more State medical service does the medical profession want?" He recounted the long list of appointments, part-time and whole-time, which involve the employment of the medical profession by the State, either centrally or locally. He said that there were about 1,000 more whole-time practitioners in the British islands in civil employ than there were in the Navy, the Army, the Air Force, and Indian Medical Service combined, and when it came to part-time employment a considerable majority of medical practitioners were doing some form of State medical service. Moreover, a great many of these services had been introduced at the distinct invitation of the profession itself, and the medical profession was divided, and always would be divided, as to how far other services now left to private practice ought to be organized by the State. For example, many practitioners believed that the average wage-earner could not be expected to provide himself with the services of specialists and institutional treatment, and that therefore the State ought to organize the provision of such services. Dr. Cox's experience led him to believe that the profession as a whole was convinced that a whole-time State medical service would be a bad thing for the profession and worse for the public, but he pointed out that if, as had been suggested by many practitioners themselves, the dependants of the insured were ever included in the National Insurance system there would be little difference between that position and a whole-time service. So long as the doctor had some work outside the State system and so long as the patient could choose his doctor there would be some difference, but it would not be great if the insured persons and their dependants were all medically provided for by the State. He did not believe such an extension was within measurable distance, mainly because the country could not afford it, but also because there were not sufficient doctors in the country to do the work properly if the dependants made the same demands on the doctors as the present insured persons did. If such an extension should come, the best hope of the profession would lie in the fact that all the developments of the National Insurance system had been in the direction of placing on the doctors themselves the responsibility for working the system properly. So long as that principle prevailed, the liberty of the doctor and his feeling of responsibility could not be seriously damaged.

Dr. Cox said that he threw out these reflections for discussion, not because he had any particular theory to advance, but because it was necessary that the profession should keep its eye on the tendencies which affected it and make up its mind which way it wanted those tendencies to move. His own personal opinion was that there was a great gain to the community in direct payment by the person who got a thing, whether it was medical attendance or boots. It encouraged self-reliance in the citizen and enabled him to speak his mind and act freely as regards the person who supplied the boots or the medical attendance in a way he could never do if the articles were supplied through a State store or a State system. Therefore he urged on the profession to stimulate every possible method of supplying what the public wanted in the medical line, other than State provision. As an instance of what the profession could do in this way, he pointed to Dr. Gordon Dill's scheme, which as an example of initiative and goodwill was worth any amount of mere grumbling at large about State encroachment on private practice, but much more difficult to do.

There were those who said it did not matter how much more or how much less State medical service the profession wanted because the question would not be settled by them. But this ignored the great social and political power of the profession. He entirely disagreed with those who belittled the political influence of the medical profession. His official experience had convinced him to the contrary, and there had never been a more striking proof of this than the recent discussion over the Dangerous Drugs Regulations. When the doctors really got busy and showed their Members of Parliament that they were seriously interested in this matter it was most striking to see how anxious the members were to meet the wishes of their medical constituents if they possibly could. They realized, if the doctors themselves did not, what an important factor the doctor could be in political life if and when he chose. Dr. Cox ended by urging those present to resuscitate the Hastings Division and to make it a useful unit in the machinery of the Association. If they were really contented (an unprecedented state of things), it was their duty to cast their ideas into the common pool. But he felt sure the time would come when they would have their own local difficulties and would be glad to know that they had behind them a national association.

The CHAIRMAN, Dr. E. W. SKINNER of Rye, Dr. G. LOCKE, Dr. F. B. LEWIS, Dr. W. MUIR-SMITH of Eastbourne, and others joined in the discussion. They all agreed on the necessity for unity and organization, and deplored the tendency to the employment of whole-time practitioners for work which private practitioners could do quite well. Dr. Muir-Smith pointed out that this tendency could be repressed if the doctors would only take the trouble. At Eastbourne, where they had a very active Division, they had got nearly all the work of the local authorities into the hands of private practitioners, and they were on the best terms with their local authorities. In fact, they had shown that the profession could by its unity, and having the national organization at its back, get almost anything in reason that it asked for.

A small committee was appointed to attempt to revive the Division, and Dr. HesseY consented to act as convener. The meeting closed with a hearty vote of thanks to Dr. Cox.

INSURANCE.

CORRESPONDENCE.

"Availability" in Emergency Cases.

SIR,—In the giving of "immediate" treatment in "emergency" cases to an insured person practitioners have variously interpreted the meaning to be given to the word "available" in the regulations. To be of avail a practitioner must be of value, use, service, or advantage to the person in such an emergency, and therefore it seems to me the term can be only in relation to the insured person and not to the practitioner, and that therefore it is of no moment or importance to contend that a practitioner was "available" because he was in the house and not sent for if the "emergency" exists. This is the only human and honourable view, and, I think I may add, its practicable exposition. A definite adoption of this view at the next conference might save much discussion at medical service subcommittees and correspondence with practitioners.—I am, etc.,

Harringay, April 17th.

A. G. NEWELL, M.D.

Dental Treatment by Insurance Practitioners.

SIR,—In reference to the circular letter issued by the Ministry of Health to Panel Committees the following words occur in Anaesthetists' Fees, paragraph (d): "where teeth are extracted by an insurance practitioner as part of his agreement," etc.

May I ask if it is part of a doctor's agreement in rural areas to extract teeth for insured patients? If so, then I take it that the capitation fee covers the dental treatment provided, and that no charge should be made. May I ask also if it is permissible to refuse to give the treatment conditionally or unconditionally?

Two issues arise: First, ought the capitation fee to include the patient's right to dental extraction by his panel doctor? Secondly, is this an unconditional right? If the answer to these two questions is in the affirmative, then the Ministry of Health is lending encouragement to dental treatment by persons unqualified in dental surgery.—I am, etc.,

Pensilva, nr. Liskeard, Cornwall, April 17th.

J. C. JONES.

LOCAL MEDICAL AND PANEL COMMITTEES.

LONDON.

Post-Graduate Courses.

THE London Panel Committee proposes to arrange for further courses of post-graduate lectures and teaching on similar lines to those followed in the courses held in previous years. The subjects proposed are at present clinical pathology and the diagnosis, treatment and prevention of venereal diseases. If a sufficient number express the desire, the Committee will endeavour to arrange for courses in general medicine and general surgery with opportunities for clinical teaching. The courses in clinical pathology, general medicine and general surgery will be held at Charing Cross Hospital; that in venereal disease at St. Thomas's Hospital. The fee for each course is £3 3s., which must be paid to the Secretary of the Panel Committee before a card of admission to the lectures is issued. In order that arrangements may be made for a start in the first week in May, applications must reach the Secretary, Staple House, 51, Chancery Lane, W.C.2, not later than April 18th. The Panel Committee is in negotiation also with the Metropolitan Asylums Board, with a view to the institution of post-graduate clinical demonstrations by the medical officers of the Board in the wards of the fever hospitals. The scheme provides that each course shall comprise a series of four or five clinical demonstrations in the wards of the hospitals, and that the fee for each course shall be one guinea, payable in advance to the Secretary of the Committee. Practitioners desirous of participating in these courses should make early application.

Chemists' Hours of Service.

Complaints have been made by practitioners in some districts that the insured persons on their lists have experienced difficulty in obtaining their medicines owing to the early

closing of chemists' shops. It is desired that concrete examples of such difficulties may be sent to the Secretary of the Panel Committee. The list of hours of service for chemists appears at the end of each *Borough Medical List*, a copy of which has been supplied by the London Insurance Committee to each practitioner on the panel.

Naval and Military Appointments.

ROYAL NAVAL MEDICAL SERVICE.

The following appointments are announced by the Admiralty: Surgeon Commanders A. C. W. Newport, M.V.O., S. Roach, and G. D. Eateiman to the *Pembroke*, additional (temporary); W. T. Haydon to R.N. Barracks, Devonport; R. W. Stairstreet to the *Orion*. Surgeon Lieutenant Commanders H. St. C. Colson and G. A. S. Hamilton to the *Pembroke*, additional (temporary); J. D. Bangay, O.B.E., to the *Victory*, for R.M. Division Portsmouth. Surgeon Lieutenants H. L. Pridham and J. W. Tighe to the *Pembroke*, additional (temporary); C. N. Ratcliffe to the *Bryony*, A. G. Taylor to the *Sandhurst*, A. W. Gunn to the *Impregnable*.

ARMY MEDICAL SERVICE. ROYAL ARMY MEDICAL CORPS.

Temporary Captain M. Bates, O.B.E., relinquishes the acting rank of Major, October 15th, 1919 (substituted for notification in the *London Gazette*, April 22nd, 1920).

Captain C. B. Hogg is placed on the half-pay list on account of ill health.

The following temporary Captains relinquish their commissions, and retain the rank of Captain: C. H. Evans, W. B. Wilson, B. A. Cheadle, W. L. Young, R. S. Dollard, J. G. M. Sloane.

Lieutenant (temporary Captain) M. F. D. Graham resigns his commission, and is granted the rank of Captain.

ROYAL AIR FORCE. MEDICAL BRANCH.

The following are granted short service commissions as Flight Lieutenants, with effect from, and with seniority of, April 4th: M. J. Calahane, O. St. L. Campion, S. E. Elphick, A. E. Jenkins, W. B. Wilson.

INDIAN MEDICAL SERVICE.

The promotion of Major A. Cameron, O.B.E., M.B., to his present rank has been antedated from October 15th to September 1st, 1915.

The promotion of Major R. S. Townsend, M.C., M.B., to his present rank has been antedated from February 1st, 1920, to August 1st, 1919.

SPECIAL RESERVE OF OFFICERS. ROYAL ARMY MEDICAL CORPS.

The following Captains relinquish their commissions and retain the rank of Captain: H. Smith, G. Day.

TERRITORIAL FORCE.

ROYAL ARMY MEDICAL CORPS.

Major J. Oweo, T.D., resigns his commission and retains the rank of Major, with permission to wear the prescribed uniform.

Major (acting Lieut.-Colonel) L. C. V. Hardwicke relinquishes the acting rank of Lieutenant-Colonel on ceasing to be specially employed.

Captain H. W. Symons to be Major.
To be Captains: Major T. P. Cole (late R.A.M.C.), with precedence as from April 10th, 1918, and relinquishes the rank of Major; Captain H. V. Walsh (late R.A.M.C.), with precedence as from December 15th, 1918. Captain A. W. A. Davies (late R.A.M.C., S.R.), with precedence as from November 24th, 1917; Captain W. H. Kerr (late R.A.M.C., S.R.), with precedence as from May 1st, 1918; Captain A. E. Chisholm (late R.A.M.C.), with precedence as from March 11th, 1918; Lieut. C. G. Teall.

2nd London Sanitary Company.—Captain R. O. Sibley resigns his commission, and is granted the rank of Major.

TERRITORIAL FORCE RESERVE.

ROYAL ARMY MEDICAL CORPS.

Major G. F. Whyte, T.D., from General List to be Lieutenant-Colonel.

DIARY OF SOCIETIES AND LECTURES.

HUNTERIAN SOCIETY, Sion College, the Embankment, E.C.—Wed., 8.45 p.m., Annual General Meeting.

ROYAL COLLEGE OF SURGEONS, Lincoln's Inn Fields, W.C.—Museum Demonstrations: Mon., 5 p.m., Professor Shattock; Ostoma. Fri., 5 p.m., Professor Keith: Peritoneal Adhesions and Intestinal Stasis.

ROYAL SOCIETY OF MEDICINE.—Special General Meeting of Fellows, Mon., 5 p.m. *Section of Odontology*: Mon., 8 p.m., Mr. G. G. Campton and Mr. John Millard: Growth of the Face. *Section of Medicine*: Clinica. Meeting at St. Bartholomew's Hospital, Tues. Tea at 4 p.m. Dr. G. Graham: Treatment of Diabetes. Dr. A. E.

Gow: Intravenous Protein Therapy. Dr. Drysdale: Splenectomy in Acoholic Jaundice. Dr. F. R. Fraser: Digitalis Treatment by the Rapid Method. *Section of Urology*: Thurs. At St. Bartholomew's Hospital, 3.30. Operations by Mr. W. Girling Ball. At 1, Wimpole Street, 8.15 p.m., Specimens; 8.30 p.m., Mr. R. Thompson: Treatment of Epispadias and of Extroversion of Bladder.

POST-GRADUATE COURSES AND LECTURES.

GLASGOW POST-GRADUATE MEDICAL ASSOCIATION, Royal Infirmary, Wed., 4.15 p.m., Dr. Katharine Chapman: X Rays in Diagnosis and Treatment.

LONDON HOSPITAL MEDICAL COLLEGE, Mon., 5 p.m., Dr. W. M. Feldman: Ante-natal and Post-natal Child Physiology.

LONDON LOCK HOSPITALS.—Clinics daily. *Lectures*: (at 91, Dean Street, W.), Mon., 2.30 p.m., Mr. Thomson: Preparation of Deteriorated Vaccines for Gonorrhoea; 5 p.m., Mr. Gibbs: Complications in Treatment of Syphilis; Tues., 2.30 p.m., Mr. McDonagh: Metallic Toxication; 5 p.m., Mr. Juler: Syphilitic Diseases of Fundus, Orbit and Ocular Muscles; Wed., 4.30 p.m., Mr. Joly: Chronic Gonorrhoea in the Male; Fri., 2.30 p.m., Demonstration of Tests used in Syphilis; 4 p.m., Mr. Abraham: Late Sequelae of Gonorrhoea in the Female. (At 233, Harrow Road, W.) Wed., 3 p.m., Mr. Ernest Lane: Venereal Disease in Women and Children.

MANCHESTER ROYAL INFIRMARY, Tues., 4.30 p.m., Dr. J. G. Clegg: Iritis and Cyclitis.

NORTH-EAST LONDON POST-GRADUATE COLLEGE, Prince of Wales's General Hospital, Tottenham, N.15.—*Special Intensive Course*: Daily, 10.30 a.m. and 11.45 a.m. Demonstrations on Clinical and Laboratory Methods; 2 p.m. and 3 p.m., Groups of Illustrative Cases; 4.30 p.m., Clinical Lectures, free to medical practitioners. First Lecture, Monday, 4.30 p.m., Sir William Hale-White on Pleurisy. Full Syllabus of Course printed in *Bulletin of Fellowship of Medicine*.

ST. JOHN'S HOSPITAL, 49, Leicester Square, W.C.—Chesterfield Lecture, Thurs., 6 p.m., by Dr. W. K. Owsley Sibley: Lupus Vulgaris and Erythematosis.

WEST LONDON POST GRADUATE COLLEGE, HAMMERSMITH, W.—Daily, 10 a.m. (and Mod.), Tues. and Fri. at 2.30 p.m., Ward Visits; 2 p.m., In- and Out-patient Clinics and Operations.

APPOINTMENTS.

HAIRE, Norman, M.B., Ch.M. Syd., one of the Honorary Physicians of the Saffron Hill Maternity Centre (Holborn, Finsbury, and City Border).

PUNCH, A. L., M.B., B.S. Lond., M.R.C.P. (Physician in

charge of Out-patients), Great Northern Central Hospital, Holloway.

STORRS, C. S., M.D. Camb., Certifying Factory Surgeon for the Colne (Launce) district.

WALSHE, F. M. R., M.D., F.R.C.P., Assistant Physician to Out-patients, National Hospital for the Paralyzed and Epileptic, Queen Square, W.C.

EDINBURGH ROYAL INFIRMARY.—*Resident House-Physicians*: H. A. Macmillan, M.C., M.B., Ch.B., to Dr. Fleming; A. Y. Cochrane, M.B., Ch.B., to Dr. E. Bramwell. *Resident House-Surgeons*: R. M. Galloway, M.B., Ch.B., to Prof. Alexis Thomson; E. M. Byes, M.B., Ch.B., to Surgical Out-patient Department. *Clinical Assistants*: E. M. Carfoot, M.D., J. E. C. Henderson, M.D., and D. Watson, M.B., Ch.B., to Dr. Logan Turner.

BIRTHS, MARRIAGES, AND DEATHS.

The charge for inserting announcements of Births, Marriages, and Deaths is 6s., which sum should be forwarded with the notice not later than the first post on Tuesday morning, in order to ensure insertion in the current issue.

BIRTHS.

PINKERTON.—On April 19th, at a nursing home in Bolin-broke Grove, S.W., to Norah Dorothy Pinkerton, B.Sc., M.B., B.S., M.R.C.S., and John McLean Pinkerton, M.C., D.Sc., M.B., Ch.B., a daughter.

WOODWARK.—On April 11th, at 4, Harley Street, W., to Hilda (née Robinson), wife of A. S. Woodwark, C.M.G., C.B.E., M.D., F.R.C.P., a son.

MARRIAGE.

CAIRN-SARKIES.—On April 13th at Paddington, Myles Denton Cairn, M.D., B.Sc. Lond., of Hove, Sussex, to Mavis, younger daughter of Mr. J. Sarkies, late I.C.S. and Mrs. Sarkies.

DEATHS.

TYTLER.—On April 9th, at 23, Broadway, Withington, Manchester, Peter Tytler, M.D., aged 71, the beloved husband of Emily Tytler.
WRIGHT.—On April 2nd, suddenly, Joseph Farrall Wright, M.R.C.S., L.R.C.P., of 46, Derby Street, Bolton.

SUPPLEMENT

TO THE

BRITISH MEDICAL JOURNAL.

LONDON: SATURDAY, APRIL 30TH, 1921.

CONTENTS.

BRITISH MEDICAL ASSOCIATION.	PAGE	CURRENT NOTES	PAGE
REPORT OF COUNCIL, 1920-21	105	PAYING PATIENTS IN POOR LAW INFIRMARIES	159
APPENDIX I. FINANCIAL STATEMENT	139	HEALTH CERTIFICATES FOR EMIGRANTS... ..	159
APPENDIX II. MEMORANDA FOR GUIDANCE OF REPRESENTATIVE BODY IN REGARD TO THE APPROVAL OF CORPORATE MEMBERS AND NOMINATING BODIES	148	ANAESTHETISTS' FEES IN INSURANCE PRACTICE	160
APPENDIX III. MEMORANDUM ON THE REPORT OF THE CONSULTATIVE COUNCIL ON MEDICAL AND ALLIED SERVICES.	151	A MEDICAL PROVIDENT SCHEME: SUGGESTED ORGANIZATION FOR LONDON	161
APPENDIX IV. QUESTIONS TO DIVISIONS ON THE REPORT OF THE CONSULTATIVE COUNCIL	153	NOTICES OF MOTION FOR ANNUAL REPRESENTATIVE MEETING, 1921	160
APPENDIX V. SUMMARY OF REPLIES OF DIVISIONS TO QUESTIONS CONTAINED IN APPENDIX IV	154	ASSOCIATION NOTICES... ..	160
APPENDIX VI. MEMORANDUM FROM THE FEDERATION OF MEDICAL AND ALLIED SOCIETIES	155	THE ANNUAL MEETING AT NEWCASTLE	163
APPENDIX VII. MEANS OF OBTAINING THE COLLECTIVE OPINION OF THE PROFESSION ON QUESTIONS OF POLICY... ..	156	INSURANCE:	
APPENDIX VIII. REPORT ON THE FUTURE OF POOR LAW INFIRMARIES: RECOMMENDATIONS	157	LONDON PANEL COMMITTEE: ANNUAL DINNER	163
		HOSPITALS AND INSURED PATIENTS	163
		CORRESPONDENCE:	163
		NAVAL AND MILITARY APPOINTMENTS... ..	163
		ASSOCIATION INTELLIGENCE; DIARY, ETC.	164

SPECIAL NOTICE TO MEMBERS.

As the subject matter of the Report of the Council contained herein will require to be dealt with by the Divisions, this "Supplement" should be carefully preserved and taken to the Division meeting, which should be called at an early date.

MATTERS REFERRED TO DIVISIONS.

British Medical Association.

ANNUAL REPORT OF COUNCIL, 1920-21.

CONTENTS.

	Page
Preliminary - - - - -	105
Finance - - - - -	107
Journal - - - - -	109
Organisation - - - - -	109
Science - - - - -	120
Medical Ethics - - - - -	122
Ministry of Health - - - - -	122
Central Representative Medical Committee - - - - -	123
Medico-Political - - - - -	124
National Health Insurance - - - - -	131
Public Health and Poor Law - - - - -	132
Hospitals - - - - -	133
Naval and Military - - - - -	134
Medico-Sociological - - - - -	135
Scotland - - - - -	135
Wales - - - - -	136
Ireland - - - - -	136
Oversea Branches - - - - -	137

Preliminary.

THE ANNUAL MEETING AT CAMBRIDGE, 1920.

1. The Council, in accordance with the usual custom, has thanked the Cambridge Executive for their work, which culminated in the meeting at Cambridge in June last. But the Association generally will desire to have placed on record here its thanks to those who were responsible for the admirable arrangements made for the reception of the Association, and especially to the Honorary Local Secretaries, Dr. J. F. Gaskell and Dr. G. S. Haynes;

its opinion that the Cambridge Meeting was from every point of view one of the most enjoyable and successful in the long line of Annual Meetings; and the special debt of gratitude which the Association owes to its President, the Rt. Hon. Sir T. Clifford Allbutt. His position as President for five years has given him a unique place in the long and distinguished list of Presidents of the Association. His unique professional position, his strong and steady support of the Association in every possible way, and the devoted service given by him during the War to the nation, the profession and the Association, made the Privy Councillorship conferred upon him just after the Cambridge meeting seem peculiarly appropriate. His unflinching courtesy and geniality have endeared him to every member of the Association who knows him.

THE ANNUAL MEETING AT NEWCASTLE IN 1921.

2. Any place would have a difficult task to follow Cambridge in holding an Annual Meeting, but, remembering the successful Meeting that was held in Newcastle in 1893, the good work of the North of England Branch in the scientific, medico-political and social spheres and the high position it holds as an active unit of the Association, the Council feels sure that under the Presidency of Prof. David Drummond the Association may confidently look forward to a Meeting at Newcastle which in its own way will stand comparison even with Cambridge.

ANNUAL MEETING, 1922.

3. In connection with the Annual Meeting, 1922, to be held at Glasgow, the Glasgow and West of Scotland Branch has nominated Sir William Macewen, C.B., as President-Elect.

4. The Council recommends:—

Recommendation.—That Sir William Macewen, C.B., LL.D., M.D., F.R.C.S., F.R.S., D.Sc., Regius Professor of Surgery, University of Glasgow, one of the Hon. Surgeons to H.M. the King in Scotland, be elected President of the Association for 1922-23.

ANNUAL MEETING, 1923.

5. The Portsmouth Division has invited the Council to hold the Annual Meeting at Portsmouth in 1923.

6. The Council recommends:—

Recommendation. That the Annual Meeting, 1923, be held at Portsmouth.

HONOURS.

7. The Council has pleasure in announcing that during the present session honours have been conferred upon the following Members of the Association.

Privy Council.

Sir T. Clifford Allbutt, K.C.B. (President).

President of Royal Society.

Professor C. S. Sherrington (Oxford).

Knighthood.

Dr. Dawson Williams, C.B.E. (Editor, *B.M.J.*).

Dr. S. Squire Sprigge, M.A. (Editor, *Lancet*).

Mr. Chas. Ryall, C.B.E. (London).

Dr. William Hodgson, J.P. (Crewe).

Dr. Alexander Jarvie Hood (Sydney, N.S.W.).

OBITUARY.

8. The Association has to deplore the loss of the following Members:—

Name.	Offices held.
Dr. Phineas S. Abraham ...	President of Section of Dermatology, 1910.
Sir William Babbie, V.C., K.C.B., K.C.M.G.	Representative of the Army Medical Service on the Central Council, and a Member of the Naval and Military Committee; Vice-President of Section, Navy, Army and Ambulance, 1912.
Dr. Henry Barnes, LL.D. ...	President of the Association, Carlisle Meeting, 1896; Secretary, Section of Medicine, 1870; Vice-President of that Section, 1893; a former President of Border Counties Branch, a Member of the Branch Council, and a former Member of the Executive Committee of the English Division; Member of Association from 1864.
Dr. Henry Blake ...	A former Chairman and Representative of the old East Norfolk Division of the East Anglian Branch.
Dr. Wm. Ironside Bruce ...	Secretary of Section of Radiology and Medical Electricity, 1910; Vice-President of Section of Electro-Therapeutics, 1913, and nominated President of the Section of Radiology and Electro-Therapeutics at the forthcoming Annual Meeting at Newcastle-on-Tyne.
Dr. Ernest Hook Buckell ...	A former President of the Sussex Branch.
Sir John W. Byers ...	At one time a Member of the Central Council and Chairman of the Irish Committee; a former President of the North of Ireland Branch and President of the Section of Obstetric Medicine and Gynaecology, 1901.
Sir Charles Alexander Cameron	Past President of the Leinster Branch.
Mr. Robert Campbell...	A former President of the Ulster Branch; Vice-President of Section of Diseases of Children, 1909.
Dr. Arthur Desborough Clark	A Member of the Executive Committee of the Brighton Division of the Sussex Branch.
Dr. Frederick Herbert Dayus	A Member of the Executive Committee and a former Vice-Chairman of the Stratford Division of the Metropolitan Counties Branch.
Sir Alexander Dempsey ...	One of the Secretaries of the Annual Meeting at Belfast, 1884; a former Secretary and Treasurer and afterwards President of the North of Ireland Branch; Vice-President of Section of Ethics, 1895.
Deputy-Surgeon-General Wm. Gerard Don, A.M.S., (Ret.)	President of Section of Navy, Army and Ambulance, 1901.
Dr. John Henry Ewart ...	A former Representative of the Eastbourne Division of the Sussex Branch; a Member of the Central Ethical Committee and a former Member of Council.
Dr. Thomas Fort ...	A former Chairman and Representative of the Lancashire and Cheshire Branch and for some years a Member of the Council of that Branch.
Sir Kendal Matthew St. John Franks	A former President of the Transvaal Branch and for some years a Member of the Branch Council; Vice-President of the Sub-Section, Laryngology and Rhinology, 1894.
Dr. Charles Brooke Gratte...	A former Member of the Executive Committee of the Monmouthshire Division of the South Wales and Monmouthshire Branch and for some years a Member of the Council of that Branch.
Dr. Montagu Handfield-Jone	Secretary 1891, Vice-President 1895, of Section of Obstetric Medicine.
Dr. Robert Harris ...	A Member of the Lancashire and Cheshire Branch Council; a former President of the Branch, and for many years Secretary of the Southport Division.
Mr. Arthur Jackson ...	A former President of the Shropshire and Mid. Wales Branch.
Dr. Thomas Fair Johnston ...	A former Secretary of the Blyth Division of the North of England Branch.
Dr. Thomas Millhouse Livingstone	Vice-President, Section of Laryngology, Rhinology and Otology, 1914.
Dr. Donald Joseph Macaulay	A former Chairman of the Halifax Division of the Yorkshire Branch.
Dr. Thomas Fraser McFarlane	President of the Dundee Branch.
Dr. James Charles McWalter	Vice-Chairman of the Dublin Division of the Leinster Branch; Vice-President of the Section of Pharmacology and Therapeutics, 1914.
Dr. Frederick Charles Mears	A Member of the Executive Committee of the Tyneside Division of the North of England Branch.
Dr. Thomas George Miles ...	A former Member of the Insurance Acts Committee.
Surgeon-Major-General Henry Foljambe Paterson, A.M.S. (Ret.)	First President of the Hong Kong and China Branch.
Dr. David Lloyd Roberts ...	President of the Section of Obstetrics, 1902.
Dr. Wm. Latta Robertson, M.C.	Honorary Treasurer of the Dundee Branch.
Sir Felix Semon, K.C.V.O. ...	President of the Section of Laryngology, 1888 and 1895.
Dr. Frederick Charles Smyth	A former Member of the Executive Committee of the Belfast Division of the Ulster Branch.
Professor Sinclair White ...	President of the Association part of 1909. One of the Secretaries of the Annual Meeting at Sheffield, 1908; Secretary of the Section of Surgery, 1906, and President, 1908.
Dr. David Yellowlees ...	President of the Psychological Section, 1885.

Dr. Edward William Mahaffy Adair, Dr. John Wilson Adam, Dr. Evan Alban, Dr. Samuel Alfred Alcorn, Dr. W. H. Allan, Major Edward Randolph Armstrong, I.M.S., Dr. Walter Robert Awdry, Dr. C. Ayres, Dr. Annie Agnes Baird, Dr. Francis Joseph Batten, Dr. David Morgan Beddoe, Dr. P. M. Belhapa, Dr. Morry's Dewes Best, Dr. R. K. Bird, Dr. George H. S. Blackburne, Dr. A. O. Boer, Dr. William Bower, Dr. Lewis Dransfield Brown, Dr. Thomas William Brown, Dr. Henry Browne, Dr. Henry William Bryant, Dr. James Patrick Thomas Burke, Dr. Harry Burton, Dr. John Kerr Butter, Dr. Johannes Avetician Calantar, Lt. Col. R. H. Castor, I.M.S., Dr. Ebert Chambers, Mr. William L. Christie, Dr. J. Vivian Church, Dr. J. P. Clifford, Lt. Col. Robert Cobb, I.M.S., (Ret.), Dr. Victor Evelyn Collins, Dr. John Connell, Dr. John Joseph Connolly, Dr. Gladys Mary Cooksey, Dr. Archibald Gladstone Corbett, Lieut. Cecil Gerald Sedgely Corner, I.M.S., Dr. James Joseph Corr, Dr. Alexander Cosgrave, Dr. Michael James Bodkin Costello, Dr. James Luke Crisp, Dr. Charles Edward Dawson, Lt. Col. Thomas Henry Delany, I.M.S., (Ret.), Dr. Robert Denman, Dr. R. T. de Silva, Lt. Col. Henry Peers Dimmock, O.B.E., I.M.S., (Ret.), Capt. Subramanya Doraisamy, I.M.S., Dr. Augustus Charles Dove, Lt. Col. Ralph Evelyn Drake-Brockman, D.S.O., Dr. W. A. V. Dwyer, Dr. Edgar Duke, Dr. Robert Joseph Dwyer, Dr. Charles Edward Eadon-Clarke, Dr. Irene Cecil Davy Eaton, Dr. Alfred Wilson Emms, Dr. George Evans, Dr. William John Strachan Ewan, Dr. Harry Fayle, M.C., Dr. John Fotheringham, Senr., Lt. Col. Thomas Howard Foulkes, C.I.E., I.M.S., Dr. Michael John Fox, Dr. George Philip Francis, Dr. Alexander George Fraser, Dr. Jean Mary Frew, Dr. A. Fuller, Dr. William Kingston Fyffe, Dr. Charles Alexander Robert Gatley, Dr. George Gautby, Dr. Ernest Wm. Graham, Dr. Andrew Moir Gray, Dr. Wm. Frederick Liddon Green, Dr. James Greenwood, Dr. Neville Griffiths, Lt. Col. Percy de Ilaga Haig, I.M.S., (Ret.), Dr. James Arthur Harrahan, Dr. L. Herschell Harris, Dr. Walter Anstice Harvey, Dr. Clarence Haslewood, Dr. John Hassall, Dr. Richard Hatch, Dr. Edwin Hegan, Dr. Daniel D. Henegan, Lt. Col. Daniel Hennesey, R.A.M.C., (Ret.), Dr. Thomas Whiteside Hime, Mr. Wheeldon Hind, Dr. Harry Hollis, Dr. Albert Wm. Dunning Hunt, Major G. Gregory James, I.M.S., Dr. John Jamison, Dr. Claude Johnson, Dr. Henry Jones, Dr. Hugh Owen Jones, Dr. John Kenrick Jones, Dr. John Drought Kenny, Dr. Augustus Keppel Reade, Dr. Robert Kirk, Dr. James Kirkland, Dr. James Gowans Laing, Dr. Timothy Wood Lee, Dr. John Leslie, Dr. Robert Murray Leslie, Dr. John Lewtas, C.B.E., Dr. Osborne Ernest Barber Linnick, Dr. Alex. Mayne Love, Dr. Lionel Francis Lovell-Keays, Dr. William Houston Low, Dr. Donald Macaulay, O.B.E., Lt. Col. Benjamin Thomas McCreery, R.A.M.C., (Ret.), Dr. G. N. MacDairmid, Dr. Robert McElvie, Dr. William Andrew McKee, Dr. Archibald Andrew McKinnon, Dr. Ronald Nimian Mackenzie, Dr. Kenneth Norman Maclean, Dr. Robert Sater Mair, Dr. Edwin Allan Maling, Dr. Guy Eugene Manning, Dr. Robert Bruce Marjoriebanks, Dr. Walter Gibson Marsden, Dr. Alexander Wm. Mather, Dr. Francis Hollingsworth May, Dr. Frank Elliott Meade, Dr. John Gordon Smith Mennie, Dr. David Mitchell, Dr. Trafford Mitchell, Dr. M. M. Mody, Dr. Ethel Amy Mordaunt, Dr. William Morrison, Dr. Selby Woodhouse Morton, Dr. George Munro, Dr. George Bain Murdoch, Dr. James Murray, Dr. Edward Herbert Myddelton Gavey, Dr. A. Y. Narayanaiah, Dr. Joseph Nee tham, Dr. George Nisbet, Dr. Walter Blake Nisbet, Lt. Col. Thomas Edward Noding, R.A.M.C., (Ret.), Lt. Col. Arthur Hollbrook Nott, I.M.S., (Ret.), Dr. Henry Barton Owens, Dr. George Shepley Page, Dr. Gerald Crécy Parnell, Dr. Maurice Paterson, Dr. Alfred William Pearson, Capt. John Walter Pigeon, I.M.S., Dr. James Lind Porteous, Dr. Thomas Power, Dr. Zachariah Prentice, Dr. Robert Harding Rains, Dr. James Herbert Rhodes, Dr. Cyril Stephen Stokes Rigby, Dr. Richard Lumley Roberts, Dr. George James Robertson, Dr. John Roger, Dr. Dermid Maxwell Ross, Dr. Kenneth Mackinnon Ross, Dr. Charles E. R. Rutland, Dr. Ernest Noel Ryeart, Lieut. N. N. Saha, I.M.S., Dr. A. E. Salter, Dr. Samuel Radford Savage, Dr. Walter Joseph Schuller, Dr. John Robinson Scott, Dr. George Broadfoot Serle, Dr. Lionel Shingleton-Smith, Dr. Edmund James Simpson, Dr. Matilda Ann Sinclair, Dr. M. Sinnetamby, Dr. David Angus Smith, Dr. Charles Edward Southwell, Dr. E. J. S. Spark, Dr. F. G. Spittel, Dr. John Spring, Dr. Louis Edward Stamm, Dr. Benjamin Hosford Steede, Dr. James Stewart, Dr. James Stothard, Dr. Peter Sturrock Sturrock, Dr. Nusservanji F. Surveyor, Dr. Robert Russell Thomas, Dr. John Hilton Thompson, Dr. Thomas Thomson, Dr. Charles Augustus Thorne, M.B.E., Dr. John Thorney, Dr. Francis Henry Thornton, Dr. Arthur Joseph Henry Thornton, Dr. Harold Tipping, Dr. Claude J. Tozer, F.S.O., Major Wilfred Warwick Treves, O.B.E., R.A.M.C., Dr. John Tubb-Thomas, Dr. Edward Turner, Dr. Charles Tweedy, Dr. Alexander Veitch, Dr. Raymond Verel, O.B.E.,

Dr. Charles William Vickers, Dr. Robert Spence Walton, Dr. Thomas Warren, Dr. George Henry Watson, Dr. Ernest Webster, Dr. William Owen Williams, Dr. Stanislaus E. A. Z. Woinski, Dr. Edward Wright.

AWARD OF THE MEDAL OF THE ASSOCIATION.

MAJOR ARTHUR MARTIN-LEAKE, V.C., F.R.C.S., R.A.M.C.

9. It is hoped that Major Arthur Martin-Leake, V.C., F.R.C.S., R.A.M.C., who is now in India, may be able to be present at Newcastle to receive the Gold Medal awarded to him in 1915.—

"*Victoria Cross*.—For great devotion to duty and self-sacrifice at Vlakkfontein, February 8th, 1902, when he went out into the firing line to dress a wounded man under very heavy fire from about forty Boers only 100 yards off. When he had done all he could for him he went over to a badly wounded officer, and while trying to place him in a more comfortable position he was shot three times. He only gave up when thoroughly exhausted, and then he refused water until other wounded men had been served."—*London Gazette*, May 13th, 1902.)

"*Bar to Victoria Cross*.—For most conspicuous bravery and devotion to duty throughout the campaign, especially during the period October 29th to November 8th, 1914, near Zonnebeke, in rescuing, whilst exposed to constant fire, a large number of the wounded who were lying close to the enemy's trenches."—(*London Gazette*, February, 1915.)

SIR DAWSON WILLIAMS, C.B.E. (Editor, *British Medical Journal*).

10. The Council has decided to award the Gold Medal of the Association to Sir Dawson Williams, C.B.E., Editor of the *British Medical Journal* for his distinguished services to the Association and the medical profession as Editor of the *British Medical Journal* from 1898. The Medal will be presented on the occasion of the President's Address at Newcastle on July 19th, 1921.

ATTENDANCES AT COUNCIL AND COMMITTEE MEETINGS.

11. A list of attendances at Council, Committee and Subcommittee meetings, from the A.R.M. 1920, to April 8th, 1921, will be published in the *B.M.J.* Supplement of May 7th.

Finance.

12. The Revenue of the Association for the year ending December 31st, 1920, again shows a substantial increase on the previous year, but the expenditure has increased in greater proportion, so that the excess of expenditure over income is over £12,000 (£12,695 11s. 7d.). For Financial Statement see Appendix I. In 1919 the balance of income over expenditure was £5,204, but this was in large measure due to the receipt during that year of £5,000 from the Government as a contribution to the cost of the Central Medical War Committee, the expenses of which the Association had met from year to year during the period, nearly four years, for which it sat; this was credited to the receipts of 1919. Further, an opportunity having occurred the stock of paper was increased by an amount equivalent to £3,259.

13. The income in 1920 was £86,372; in 1919 it was £80,223. For a correct comparison of the two years, however, the sum of £5,000 credited to 1919 in respect of the Government Contribution for the Central Medical War Committee must be deducted from the receipts of that year, and when this is done it is seen that the ordinary income of 1920 exceeded the ordinary income of 1919 by £11,139; of this enhanced amount nearly the whole was due to increases in subscriptions (£3,920), and in receipts from advertisements (£6,345), making together £10,265. The true position when a comparison is made between 1919 and 1920 is, therefore, rather more favourable to the latter year than might appear from the crude figure given above. The increase under the head of subscriptions was due in part to an increase in the total number of Members, and in part to the receipt, too late for inclusion in the accounts for 1919, of certain remittances due during that year. The rest of the increase in income is due in the main to the receipt of a higher rental from the Cinema Company and the payment by it of arrears.

14. The total expenditure for 1920 was £97,171, to which is to be added £1,096 written off investments and £200 off the Library; when these amounts are added to the actual expenditure the total amounts to £98,467. In 1919 the comparable figure was £75,018. The increase in 1920

over 1919 was therefore £23,449. In 1920, however, the expenditure on general repairs, upkeep and alterations was £3,907 compared with £283 in 1919. This large increase was in the main due to the cost of repairing, cleaning, and redecorating the Association's house; very little had been done in the way of repairs since the house was taken into use in 1908, and during the war it was difficult to get even trifling defects attended to. The opportunity was taken to improve the lighting and ventilation of the Council Chamber, and to provide in the basement a luncheon room and kitchen for the clerical staff; this has been much appreciated by the staff and is managed by a Committee elected by it. The Council made a grant of £110 towards furnishing. The architects' fees for plans of the alteration amounted to £177 7s. In the accounts for the last six years a sum of £1,000 has been written off for each year for depreciation of premises; in view of the amount expended on repairs in 1920 no such deduction has been made in the present accounts.

GENERAL ASSOCIATION EXPENSES.

15. General Association Expenses rose from £1,539 in 1919 to £5,472 in 1920. It will be seen from Abstract A that more than half of this increase of £3,932 is accounted for by further payments (Plaintiffs' costs) in the Pratt case. Legal charges for advice in connection with the proposal that the Association should become in part a Federation amounted to £114. Disbursements through the Science Committee (Abstracts A and B), increased from £445 in 1919 to £1,119 in 1920 owing in the main to two causes—firstly, the return of peace made possible the resumption of laboratory work, and secondly, the institution of British Medical Association lectures. These lectures, which involved an expenditure of £268, are a new and successful feature in the Association's work.

16. The cost of Dr. Macdonald's mission to South Africa, undertaken by desire of the Council in response to a request from the South African Branches that a representative from home should attend the Medical Congress at Durban and visit each Branch, was £600.

GENERAL MEETINGS AND COMMITTEES.

17. The expenditure on the Representative Meeting, the Secretaries' Conference and the Sections of the Annual Meeting, and on the Meetings of Council, was (Abstract B) £3,830, or £894 more than in 1919, owing chiefly to increased cost of printing the agenda, etc., and to the expenses of the Sections at the Annual Meeting at Cambridge.

18. In the accounts for 1920 the cost of the Scottish Committee has been transferred from Abstract B (Central Committees) to the Profit and Loss Account, where it has been customary to show the cost of the Irish Committee. Allowance being made for this it will be seen that the expenditure, £9,396, of Central Committees in 1920 was £617 in excess of that for 1919; the Committees chiefly responsible are the Organisation, which spent £983 more and the Hospitals Committee which spent £110 more than in 1919, the Ministry of Health Committee which increased its expenditure from £140 to £467, and the Science Committee which disbursed £268 for lectures. The Office Committee, a new charge, cost £333. On the other hand several Committees reduced their expenditure; the Insurance Acts Committee showed the very substantial reduction of £1,404 the Central Ethical Committee spent £206 less, the Medico-Political £131 less, and the Naval and Military Committee £83 less.

CENTRAL STAFF EXPENSES.

19. The expenditure under this head (Abstract E) rose from £8,695 to £11,191, owing in the main to increases in the salaries of the staff rendered necessary by the altered value of money and increased cost of living. As from October 1st, 1920, the salary of the Medical Secretary was increased to £1,500, of the Deputy Medical Secretary to £1,050, and of the Scottish Medical Secretary to £1,000, rising by annual increments respectively to £1,800, £1,400 and £1,250.

FINANCIAL SECRETARY AND BUSINESS MANAGER.

20. Mr. W. E. Warne, the Financial Secretary and Business Manager, having reached the age of retirement, will shortly leave the service of the Association. A Selection Committee previously examined the applications for the post and recommended three applicants for consideration by the Council, which, at its meeting on April 20th, 1921, appointed Mr. L. Ferris Scott, C.A., to the position of Financial Secretary and Business Manager.

APPORTIONMENT OF MEMBER'S SUBSCRIPTION.

21. The following shows how the subscription of a member was apportioned towards defraying the expenses of the Association for the year ending December 31st, 1920:—

	£	s.	d.
General Association Expenses ...	5,472	4	0
Central Meeting Expenses ...	9,396	6	10
Central Premises Expenses ...	7,373	5	3
Central Printing, Stationery and Postage Account ...	2,402	1	9
Central Staff Account ...	11,191	8	0
Library Account Expenses ...	758		7
Journal Account Expenses ...	12,166	8	9
Grant to Irish Committee ...	1,183		9
Grant to Scottish Committee ...	1,633	1	1
Capitation Grants to Branches ...	3,251	2	3
Subscriptions written off for deaths ...	2,300	1	8
Written Off Investments, Depreciation, Advertisement Reserve etc. ...	1,546	1	1
		<u>£</u>	<u>2</u> <u>0</u>

ESTIMATE OF EXPENDITURE AND RECEIPTS FOR 1921.

22. The following figures represent an approximate forecast of the probable expenditure and revenue for the current year:—

	EXPENDITURE.		Estimate for 1921.
	1920	Estimate for 1921.	
	£	£	£
General Association Expenses	5,472	2,672 Decrease	2,800
Central Meeting Expenses ...	9,396	304 Increase	9,700
Central Premises Expenses ...	7,372	3,372 Decrease	4,000
Central Printing, Stationery and Postage Account ...	2,402	148 Increase	2,550
Central Staff Expenses ...	11,191	1,009 Increase	12,200
Library Account ...	758	22 Increase	780
Journal Account Expenses ...	51,958	592 Increase	52,550
Irish Committee ...	1,183	...	1,183
Scottish Committee ...	1,633	...	1,633
Capitation Grants ...	3,251	200 Increase	3,451
Arrears Written off ...	2,300	247 Decrease	2,053
Depreciation ...	1,296	1,096 Decrease	200
Estimated Total Expenditure	<u>£93,100</u>
	RECEIPTS.		
Subscriptions ...	42,393	10,000 Increase	52,393
Advertisements ...	31,916	5,000 Increase	36,916
Sundry Sales of Journals ...	7,876	...	7,876
Investments and Rents ...	3,561	200 Decrease	3,361
Estimated Total Revenue	<u>£100,546</u>
Estimated Total Revenue	£100,546
Estimated Total Expenditure	93,100
Estimated Surplus 1921	<u>£7,446</u>

WORK OF THE OFFICE COMMITTEE.

23. The Office Committee, which was instituted last year and consists of the Chairman of Representative Meetings, the Chairman of Council, the Treasurer, and the Editor, the Medical Secretary and the Financial Secretary, has met six times during the present Session and has done much useful work in co-ordinating the departments in the Office, in attending to various matters concerning the premises, and in keeping in touch with the requirements of the staff. Much of the work of the Committee consists of that adjustment as between departments which contributes greatly to easy working and is therefore very important, but it is difficult if not impossible to describe it in detail.

24. The Common Room, which was hardly ever used by members, has been turned into an office, and thus additional room, which was sorely needed, has been given to the clerical staff of the Medical Department. The basement, which was formerly used as a lumber room, has now been transformed partly into storage room, partly into rooms in which stencilling can be done, and partly into a Staff luncheon room and kitchen, as mentioned in paragraph 14. The provision of storage accommodation in the basement has released a room on the third floor which has been placed at the disposal of the Card Register Department, a department which has long required room for expansion.

THE WORK OF THE INTELLIGENCE DEPARTMENT.

25. The work of the Intelligence Department has developed along the lines laid down last year. Its function is so to deal with the mass of routine work as to ensure that no social or economic development, national or local, which may at a later stage touch the interests of the medical profession, passes unnoticed at the outset through the pressure of more urgent work. Its progress is marked by the increase in the number of calls made upon its services. The work involves close scrutiny of all public and private Bills on their introduction, parliamentary records, a considerable volume of official literature, a number of professional journals, and a daily average of from 30 to 40 cuttings from the London and Provincial press. Matters requiring immediate attention are brought to the notice of the appropriate department, and all information acquired in the course of the preliminary survey is recorded in the form found to be most readily available for future reference. Special enquiries have been carried out in one or two cases. Local newspaper cuttings of medical interest are always welcomed.

"British Medical Journal."

26. The gross cost of the production and distribution of the *British Medical Journal*, including all editorial and a proportion of the managerial expenses, was £51,958. The receipts from advertisements, sales to non-members, and a few small items amounted to £39,792, so that the net cost of the *Journal* to Members of the Association was £12,166, or 8s. 9d. a head for the year, including postage. This may be put in another way by stating that while the gross cost of producing a single copy of the *Journal* and supplying it to a Member was 9½d., the cost to him was 2½d. To a non-member the price of a single copy of the *Journal* including postage is 1s. 4d. The charges for postage of the *Journal* to Members amounted to £5,731 as against £4,082 in the previous year; this increase of £1,649 was for the main part due to the increase of the home postal rate from one half-penny to a penny, but in part also to the increase in the number of Members. The cost of address bands (material and labour) rose from £133 to £323; it is seen, therefore, that the distribution of the *Journal* to Members cost £1,839 more in 1920 than in 1919. The cost of production increased by £9,104. The Association pays Union rates; increases in the wages of compositors, machine hands, and generally of all printers' workmen were responsible for £4,835; increased expenditure on paper accounts for £2,118; these two items amount together £6,953. The remainder of the increased expenditure is for the most part due to increments of salary to members of the editorial and managerial staffs, but it may be noted that the new postage rate on correspondence has increased expenditure under this head by £219.

27. The average number of copies of the *British Medical Journal* printed weekly rose from 24,520 in 1919 to 26,195 in 1920. Owing to the enormously increased cost of printing and paper, the Council on December 17th, 1919, resolved (as recorded in last year's Report of Council) that, save on exceptional occasions, the maximum number of pages in any issue of the *Journal* should not exceed 104. This number was exceeded on ten occasions only. In order to effect economies in the cost of printing by abolishing night work it was decided that the *Journal* should be sent to press earlier than formerly. The change was made in April, 1920.

28. In September, 1920, new postal rates for newspapers came into force, and their effect was to double the cost of postage of the *Journal*. Until then it was possible, by reducing the number of pages of the *Journal*, including editorial matter, Supplement and advertisements, to 92, to keep within the ½d. postal rate. Since September the home postage on a copy of the *Journal* containing 92 pages or less has been 1d.; on those issues which contained more than 92 pages it has been 1½d. In view of this great increase of expenditure on postage an endeavour has been made to keep the *Journal* within 92 pages each week.

29. The publication of the Proceedings of the Annual Meeting at Cambridge, which had occupied nearly 236 pages of the *Journal*, was completed in the issue of December 25th, 1920. During the year the publication of the Proceedings of Council, which had been in abeyance during the war, was resumed. The Current Notes in the Supplement have been extended and developed in various directions with the object of keeping Members informed, week by week, of matters which are being dealt with by the standing committees of the Association. Space is

always held available in that column for brief notes on current matters of interest, setting out what the Association has done and is doing in various fields of activity.

30. The Journal Committee continues to exercise strict supervision over advertisements tendered for publication in the *Journal* and has found it necessary to exclude a considerable number which for one reason or another have not conformed to the policy and requirements of the Association.

31. During the year Mr. Albert Lucas, F.R.C.S., who had served on the Journal Committee since 1909 and was its Chairman for seven years, including the whole period of the war with its many and great difficulties, ceased to be Chairman, and the Council on June 8th accorded to him a warm vote of thanks for his services. On July 15th the Journal Committee elected Dr. J. A. Macdonald to be its Chairman for the ensuing year; during Dr. Macdonald's visit to South Africa, Dr. T. W. H. Garstang, Chairman of Representative Meetings, acted for him. Dr. R. Scott Stevenson has been appointed Sub-Editor of the *Journal* and took up his duties at the New Year.

Organisation.

QUESTION OF EFFICIENCY OF CONSTITUTION AND MACHINERY OF THE ASSOCIATION.

32. The Council has carefully considered the instruction contained in the following Minutes 155, 160 and 167 of the Annual Representative Meeting, 1919:—

Minute 155. Resolved: That this Meeting is of opinion that much closer touch and more personal interchange of views between Headquarters and Divisions, and also between individual Branches and Divisions, should be aimed at, and feels assured that by such means reconciling views would more readily be reached and concerted action made effective.

Minute 160 Resolved: That the following motion by Plymouth be referred to the Council for consideration and report:—

That amendments be made to the existing Regulations or By-laws, or if necessary the same be repealed and new ones adopted, whereby more prompt and active steps can be taken in matters of urgency and importance to secure quicker decisions and results, rather than by the present system of referring such matters to and from Divisional, Branch and Council Meetings, by which much valuable time is lost.

Minute 167. Resolved: That during the ensuing year the Council of the Association shall make a scrutiny of the existing local and central machinery of the Association and the By-laws controlling this, with a view to the discovery of possible defects or deficiencies and to the correction of the same, and report with recommendations.

33. A careful detailed scrutiny of the constitution and machinery of the Association has been made accordingly, the Organisation Committee having, with the approval of the Council, appointed a Special Sub-Committee to deal with the matter in the first instance. Sir Jenner Verrall, LL.D., who was a member of the Constitution Committee appointed by the Annual Meeting at Ipswich, 1900, has acted as Chairman of the Sub-Committee. The Sub-Committee dealt also with the question whether or no the Association should take power to become in part a federation of medical bodies. On that subject the Council has reported separately (see *B.M.J.* Supplement, March 5th (page 55) and this Supplement (page 119). The Sub-Committee held 23 meetings.

34. With certain exceptions, the present report of the Council deals only with matters in respect of which the Council proposes change or adjustment of the constitution or machinery of the Association. During or as a result of its scrutiny of the machinery, the Council has dealt with a large number of other matters. In respect of some of these, special action has been taken, e.g., a Medico-Sociological Committee has been provisionally set up, the Model Rules of Organisation of Divisions and Branches in the United Kingdom are being amended to provide that Executive Committees and Branch Councils shall have power to co-opt persons who are members of the Association, and the question of the use of bankers' orders in connection with the payment of the Association subscription has been dealt with.

35. The Council is glad to report its conclusion that the constitution and machinery of the Association have on

the whole proved well suited for carrying out the objects of the Association. The changes recommended in the following report are variations in the present constitution, or in present procedure, which experience seems to show would help the Association in keeping abreast of the times and make it still fitter than at present to fulfil its work for its members.

36. As in the case of all other voluntary bodies, medical and non-medical, the Association comprises members who realise the importance of effective organisation and members who do not. In every Division and in every Branch of the Association there are such members. The Council is glad to note evidence of increasing recognition by members of the need of that watchfulness and alertness on the part of the Divisions and Branches which are necessary elements of the life of a body representative of the medical profession. The percentage of members who take a keen interest in public questions affecting the profession is a steadily increasing one.

37. Recognising that the interests, professional and public, committed to the care of the Divisions and Branches, cannot afford to be compromised by neglect of duty on the part of the Officers of those bodies, the Council desires to remind the members of the Association of the duty incumbent upon them, of appointing or retaining on the Executive of the Division and Branch, only such members as can be depended upon to carry out the work for which they hold office.

ORDER FOLLOWED IN THIS REPORT.

38. Taking the order of the Articles and By-laws as the most convenient, the Council states its conclusions and recommendations under:—

(I.) Membership; (II.) Divisions and Branches; (III.) Representative Body; (IV.) Referendum; (V.) Council; (VI.) Committees; (VII.) Officers.

39. It must be clearly understood that the object of this report is to initiate in the Divisions, and then in the R.B., a discussion on the principles enunciated in the Recommendations. When the Divisions and Representative Body have decided as to the recommendations made, the Council will, at the A.R.M. 1922, so far as necessary, submit draft amended Articles or By-laws, so that while the general discussion will take place this year the changes in the constitution of the Association which are agreed upon will not come into force until after the A.R.M. 1922.

(I.) Membership.

ELIGIBILITY FOR MEMBERSHIP.

(Article 3.)

40. As regards the criterion for eligibility for membership in the case of practitioners not resident within the area of any Branch of the Association, there are now a number of medical qualifications additional to those "described in Schedule A of the Medical Act, 1858," which entitle to registration in the United Kingdom, and provision ought to be made for them.

Recommendation—That Article 3 be brought up to date so as to provide that any medical practitioner who does not reside within the area of any Branch, and who, though not registered in the United Kingdom, is possessed of a qualification registrable there, shall be eligible for membership of the Association.

ELECTION BY BRANCHES.

(By-law 5.)

41. Ever since the reorganisation of the Association in 1902, the By-laws have provided that applications for election by candidates resident within the area of a Branch in the United Kingdom shall be forwarded by the candidate to the Honorary Secretary of the Branch. In practice, the Council finds that it has long been the custom for the applications, which are frequently accompanied by a remittance, to be sent direct by the candidate to the Head Office, the latter forthwith registering them and forwarding them immediately to the Branch Secretary. For this existing practice there is obviously much to be said.

Recommendation—That it be an instruction to the Council to take steps for verbal amendment of By-law 5 (1) so as to provide that candidates for membership resident in the United Kingdom, shall forward their applications to the Head Office, and that thereupon the latter shall at once notify both the Division and Branch Secretaries concerned.

ELECTION BY COUNCIL (APPLICANTS OUTSIDE BRANCH AREA). (By-law 6.)

42. Candidates resident outside the area of the Branches of the Association often find it difficult to procure the 3 approving signatures at present required by By-law 6. The requirement has probably prevented many desirable candidates from applying.

Recommendation—That it be an instruction to the Council to take steps for amendment of By-law 6 (4th and 5th lines) so as to provide that only 2 approving signatures shall be required in respect of a candidate not resident within any Branch area.

43. By-law 6 (last line but 1) provides that at least a month's notice be given to the members of the Council of the application for election of a member not resident in a Branch area. The idea was that members of the Council might in the interval make enquiries as to the desirability of any of the candidates. In practice this is not done, and there seems to be no advantage in the requirement. By far the greater number of candidates are members of the Services and thus require no approving signatures. The existing requirement means special circularisation of the members of the Council three weeks before the main Agenda of the Council meeting is issued, and the Council considers this expense unnecessary.

Recommendation—That it be an instruction to the Council to take steps for amendment of By-law 6 (last line but one) so as to provide that in respect of the proposed election by the Council of a candidate not resident within a Branch area notice shall be sent to each member of the Council with the Agenda of the meeting at which the election is proposed to be held.

(II.) Divisions and Branches.

QUESTION OF NON-MEMBERS BEING ELIGIBLE ON OCCASION FOR MEMBERSHIP OF BRANCH COUNCILS AND DIVISION EXECUTIVE COMMITTEES.

(By-laws 16 and 19.)

44. The Council is legally advised that existing By-laws 16 and 19 do not make it clear whether persons not members of the Association could, if so desired, be placed on the Branch Council or Division Executive Committee. The Council considers that it should be made clear that non-members of the Association cannot be made members of the Branch or Division Executive.

Recommendation—That it be an instruction to the Council to take steps for amendment of By-laws 16 and 19, as to local management of Branches and Divisions, so as to make it quite clear that a Branch Council or Division Executive Committee may not include persons not members of the Association.

MEMBERS OF COUNCIL AND MEMBERSHIP *ex officio* OF BRANCH COUNCIL.

(By-law 16.)

45. The Council considers that a member of the Council should not be, *ex officio*, a member of any Branch Council except that of the Branch in the area of which he or she resides. This will be all the more desirable if the R.B. approves the suggestion made later in this report that the members of Council elected by the R.B. shall be elected by groups representing respectively England, Wales, Scotland and Ireland. If this were passed, obviously it would, for example, be useless for 12 members of Council to be on the Branch Council of every English Branch.

Recommendation—That it be an instruction to the Council to take steps for amendment of By-law 16 (a) so as to provide simply that the Branch Councils in the U.K. shall include, as member(s) *ex officio*, the member(s) of the Council, if any (other than representing the Services or the Oversea Branches), resident in the area of the Branch.

HONORARY SECRETARIES OF DIVISIONS, AND MEMBERSHIP *ex officio* OF BRANCH COUNCIL.

(By-law 16.)

46. The Council is convinced that it will tend to better co-ordination and efficiency of the machinery of the Association if the Honorary Secretary of each Division

is *ex officio* a member of the Branch Council. Some Branches already have Rules to this effect, and the arrangement works well.

Recommendation.—That it be an instruction to the Council to take steps for amendment of By-law 16 so as to provide that the *Honorary Secretaries of the Divisions* of a Branch (*i.e.* one from each Division) shall be members *ex officio* of the Branch Council.

QUESTION OF REPRESENTATION ON OCCASION OF LOCAL STATUTORY COMMITTEES AND OTHER LOCAL MEDICAL SOCIETIES ON BRANCH COUNCILS AND DIVISION EXECUTIVE COMMITTEES.

(By-laws 16 and 19.)

47. **Recommendation.**—That it be an instruction to the Council to take steps for amendment of By-laws 16 (d) and 19 (e) so as to give Branches and Divisions the power of placing upon their Councils and Executive Committees, not only members of Local Medical Committees and medical members of Insurance Committees under the National Insurance Act, 1911 (as at present), but *medical members of any local Council or Committee under any Act whatsoever, and representatives of any local medical societies* (being in either case members of the Association).

COMPOSITION OF EXECUTIVE COMMITTEE OF DIVISION.

(By-law 19.)

48. By-law 16 (e) provides that a Branch may appoint to serve on its Branch Council "such other members as the Branch may by its Rules decide," but By-law 19 (e) does not give specific similar power to a Division.

Recommendation.—That it be an instruction to the Council to take steps to bring By-law 19 (e) into line with By-law 16 (e).

POWERS OF COUNCIL IN CONNECTION WITH WORK OF BRANCHES.

49. The Council is of opinion that provision should be made in the By-laws specifically empowering the Council to deal with inactive Branches.

Recommendation.—That it be an instruction to the Council to take steps for insertion of a new By-law empowering the Council to organise any Branch which may have become unorganised or inactive, and to act for such Branch pending its re-organisation.

DUTIES AND POWERS OF BRANCH COUNCILS IN CONNECTION WITH WORK OF DIVISIONS.

(By-law 17.)

50. The Council has considered By-law 17 (co-ordination of policy of Divisions), and is of opinion that the duties of a Branch Council in relation to the work of a Division should be made more definite.

Recommendation.—That it be an instruction to the Council to take steps for amendment of By-law 17 to read as follows ((b) (c) and (d) are proposed additions to the present By-law):—

Branch Council and Work of Divisions.

" 17. It shall *inter alia* be the duty of every Branch Council:—

- (a) To advise the Divisions forming the Branch in matters of policy affecting the medical profession, with a view to promoting a common policy throughout those Divisions.
- (b) To suggest to the Divisions concerned, where considered necessary or desirable by the Branch Council, or in the case of inactivity of a Division, to the Council, such modification of Division areas as would, in the opinion of the Branch Council, contribute to the more effective working of such Division or Divisions, and to advise the Council thereon from time to time.
- (c) To call, when deemed necessary or desirable by the Branch Council, joint meetings of the members of two or more Divisions for the purpose of discussing matters in which those Divisions are jointly interested.

(d) To take, where considered necessary or desirable by the Branch Council, action to organise any Division which may have become unorganised or inactive, and pending such reorganisation to act for such Division.

(e) To report to the Council upon the questions dealt with by such advice or action in all cases in which such a report is considered by the Branch Council to be necessary or desirable, or is requested by the Council."

QUESTION OF SUB-DIVISIONS.

(By-law 21 (1).)

51. In the experience of the Council, By-law 21 (1) as to Sub-Divisions, made in 1914, is an unnecessary and undesirable complication of the machinery of the Association. Practically no Division has taken advantage of it. Areas which would appear to require special treatment of the kind suggested in the present By-law had better be made separate Divisions.

Recommendation.—That it be an instruction to the Council to take steps for deletion of By-law 21 (1), as to Sub-Divisions.

JOINT COMMITTEES OF DIVISIONS.

(By-law 21 (2) and (3).)

52. In connection with By-law 21 (3) as to Joint Committees of Divisions, the Council considers that it would be simpler and better if any joint committee the Divisions desired to appoint were appointed through Division Meetings convened by the Honorary Secretaries of the Divisions, instead of the existing arrangement (By-law 21 (3)) whereby the joint meetings can be convened only by the Branch Secretary or Secretaries.

Recommendation.—That it be an instruction to the Council to take steps for amendment of By-law 21 (3) to read somewhat as follows:—

"(3) Where the members of two or more Divisions desire to meet in combination for the purpose of discussing matters in which those Divisions are jointly interested, or for the appointment of Joint Committees as aforesaid, such meetings shall be convened by the *Honorary Secretaries of those Divisions*, or, by agreement, by one of such Secretaries, or, if necessary, by the Branch Council."

ORDINARY AND SUPPLEMENTARY GRANTS.

(By-laws 23-6.)

53. The Council is elsewhere recommending (*see para 135 of this Report*) that the A.R.M., 1921, amend By-law 23 so as to empower the Council to pay ordinary grants to Branches up to a maximum of 6s. a head (instead of the present 4s.).

54. Under such circumstances as have in some areas occurred, for example during the War, the Council finds that the work of a Division or Divisions may be interfered with by non-activity of the Branch Council, whereby the financial provision intended (By-laws 23 and 26) to meet the needs of the work of the Division does not reach the latter.

Recommendation.—That it be an instruction to the Council to take steps for amendment of By-law 23 (1) by addition of a provision to the effect that, in exceptional circumstances, and at the discretion of the Council, a portion of the ordinary annual grant to a Branch may be paid by the Treasurer of the Association *direct to a Division or Divisions of a Branch*, instead of to the Branch.

55. The question has arisen whether a second grant, or second instalment of grant, paid by a Branch Council to a Division in a given year is not really a supplementary grant within the meaning of By-laws 24-5, and, as such, payable by the Council and not the Branch Council. It is obvious to the Council that the supplementary grant provided for by By-laws 24-5 is a grant supplementary to the ordinary grant made by the Council to a Branch, and not at all necessarily to a sum paid by a Branch Council to a Division. The Council considers however that By-law 26 should be verbally amended so as to obviate any possible doubt. It would be a serious matter if the time of the Council, already heavily mortgaged, were to be taken up in dealing with ordinary applications by Divisions to their Branch Councils for further grants

which the Branch Council can make from funds in its hands.

Recommendation.—That it be an instruction to the Council to take steps for verbal amendment of By-law 26 ("Application of Grants") to read, in the last line but 2:—" . . . such sum or sums as the Branch Council may from time to time consider necessary to enable the Division to defray its expenses."

NEED FOR BETTER ORGANISATION OF WORK OF DIVISIONS AND BRANCHES: QUESTION OF RULES.

56. It is impossible for any Division or Branch to work effectively which is not in possession of up-to-date Rules. Rules which are obsolete are of little use, and sometimes an actual danger, to the body possessing them.

(A.) RULES OF DIVISIONS AND BRANCHES IN THE BRITISH ISLANDS.

(1) Rules of Organisation.

57. The Council finds that of the 213 Divisions and Division-Branches in the British Islands, there are 81 which are without Rules of Organisation. The Rules of 94 out of the 132 Divisions which have such Rules date back to before the war, and the Rules of 68 of them to before 1906. They are thus, in ways more or less numerous, out of date.

58. Similarly, of the 36 Branches in the British Islands of more than one Division, 5 are not in possession of Organisation Rules, and of the 31 which have such Rules, the Rules of 15 date back to before 1906.

(2) The Revised Ethical Rules.

59. The Annual Representative Meeting, 1919 (Min. 173) urged all Divisions and Branches in the British Islands to adopt the Rules governing Procedure in Ethical Matters, approved by that Meeting. There are still 73 Divisions and Division-Branches, and 6 Branches of more than one Division, which have not adopted the Rules. Till these Divisions and Branches have adopted the Rules, and notified the Council of their adoption, they have thus no means of making their decisions binding on their members or of dealing effectively with ethical matters. Such a Division or Branch is helpless as regards the points just mentioned, nor could it be allowed by the Council to avail itself of the Notices in the *British Medical Journal* as to appointments.

Adoption of Rules a Simple Matter.

60. On application to the Head Office the Council at once sends to any Division or Branch Secretary sufficient copies of the Model Rules of Organisation or of the Revised Ethical Rules for issue to all the members thereof with the Agenda of the meeting at which they are to be adopted. When adopted, all that is required is for the Division or Branch Secretary to notify the Medical Secretary, and when approved under the standing authority given by the Council, the Rules become operative forthwith.

61. It should further be borne in mind that the Rules of the Home Divisions and Branches, adopted and approved as above, are by special arrangement by the Council printed at the Head Office, at the cost of the central funds, in convenient booklet form, sufficient copies being then sent to the Division Executive Committee or Branch Council for issue to all the members of the Division or Branch, as well as copies to hand to new members on election.

Recommendation.—That the Annual Representative Meeting, 1921, strongly urges the Divisions and Branches in the British Islands not already in possession of Rules of Organisation of date subsequent to November, 1918, to adopt forthwith Rules of Organisation based upon the latest Model Rules of Organisation supplied by the Council.

Recommendation.—That the Annual Representative Meeting, 1921, strongly urges all Divisions and Branches in the British Islands which have not already adopted the Revised Rules governing Procedure in Ethical Matters, as approved by the Representative Body, 1919, to adopt those Rules forthwith.

Recommendation.—That it be a standing instruction to the Council to report to the Annual Representative Meeting the names of all Divisions and Branches in the British Islands which are without either Rules of Organisation or the Revised Ethical Rules approved by the Representative Body in 1919.

QUESTION OF RECOGNITION OF DIVISIONS AND BRANCHES WHICH HAVE NOT ADOPTED RULES.

62. The Council considers it of great and urgent importance that every Division and every Branch should be in possession of Organisation Rules and Rules as to Procedure in Ethical Matters, and is of opinion that no group of members should be permanently or finally recognised as a Division or a Branch unless they are in possession of Rules of Organisation and Rules as to Procedure in Ethical Matters (in the case of the British Islands, the Revised Ethical Rules urged by the A.R.M., 1919, for adoption). The Council is legally advised that effect can be given to this principle by amendment of existing Article 12, and that such amendment would not be inconsistent with Article 16 ("Autonomy of Divisions and Branches") or with any other Article or any By-law.

Recommendation.—That it be an instruction to the Council to take steps for amendment of Article 12 (2) to provide that no new group of members within the British Islands shall be finally recognised as a Division or as a Branch until such Division or Branch shall have adopted Rules of Organisation and the current Rules governing Procedure in Ethical Matters, and until such Rules shall have been approved by the Council.

(B.) OVERSEA DIVISIONS AND BRANCHES.

63. As is recognised explicitly in Article 16 and By-laws 15, 18 and 22, the conditions in the Oversea Divisions and Branches differ in many ways from those at home, and materially from one Division or Branch to another. For these reasons the Council and Representative Body have up to the present refrained from recommending any special Rules for adoption by those Divisions and Branches generally.

64. None the less, the Council recognises the importance of the Branches of the Association everywhere having at least Rules of Organisation. Of the 61 Oversea Divisions and Division-Branches, the Council is in possession of Rules of only 23. Of the 3 Oversea Branches of more than one Division, the Council is in possession of Rules of 2.

Recommendation.—That it be an instruction to the Council to draw the attention of those Oversea Divisions and Branches not in possession of such Rules, to the importance of every Division and Branch having up-to-date Rules of Organisation and Rules governing Procedure in Ethical Matters; and to draw the attention of all the Oversea bodies to the importance of keeping the Council duly supplied with copies.

POSTAL VOTING BY MEMBERS.

(NOTE—For question of postal voting by members on *Referendum*, see Section (IV.) of this Report.)

65. Considerable attention has been given to proposals that further facilities should be given for postal voting. In the opinion of the Council it is inadvisable to extend these powers of individual postal voting further than they at present exist. There are few, if any, similar bodies in which the individual member has greater power to influence the affairs, including the policy, of the organisation than is the case in the Association.

66. As matters stand, postal voting is already, or can be, adopted as regards election of members of Council, Division and Branch Officers, Representatives, Deputy-Representatives, etc., if the Division or Branch so chooses. But as regards voting on matters in general, including especially questions of policy, votes cast in meeting after discussion of a given subject are in the opinion of the Council of so much greater value than votes given through the post, that the Council is against anything that would tend to do away with the Divisional Meeting and the discussion thereat. These, in the opinion of the Council, are essential for the formation of instructed opinion.

(III.) Representative Body.

FORMATION OF CONSTITUENCIES.

(By-law 33 (3).)

67. At the present time the only reason for which the Council can grant separate representation to a Division which has less than 50 members is "special difficulties as to holding joint meetings with neighbouring Divisions." Experience goes to show that there are sometimes other reasons which should influence the Council in its decision, and the Council therefore asks to be given power to use its discretion in this matter.

Recommendation.—That it be an instruction to the Council to take steps for amendment of By-law 33 (3) so as to provide (simply) that the Council shall have power to give separate representation to any Division, though of fewer than 50 members, when it appears to the Council to be desirable.

TIME OF ELECTION OF REPRESENTATIVES.

(By-law 35 (1).)

68. At present Representatives can be elected not more than nine months nor less than four weeks before the A.R.M. at which they take office. In the opinion of the Council it is important that the Representatives should be appointed at least 2 months before the A.R.M., in order that, as prospective Representatives for the ensuing year, they may follow closely the work of their Constituencies and come to the A.R.M. fully instructed thereon.

Recommendation.—That it be an instruction to the Council to take steps for amendment of By-law 35 (1) so that the Representatives shall be elected not more than 9, nor less than 2 months before the A.R.M. at which they take office.

ELECTION OF REPRESENTATIVES BY GENERAL MEETING OF CONSTITUENCY OR BY VOTING PAPERS?

(By-law 35 (1).)

69. Indecision and difficulty have been caused by the fact that existing By-law 35 (1) leaves the decision whether the election of the Representative(s) is to be by General Meeting of the Constituency or by voting papers, to be "as the said Constituency may decide." In practice, to get such a decision may be rather difficult, as a Constituency frequently comprises two or more Divisions. The Council considers that there should be a ready means of settling the mode of election.

Recommendation.—That it be an instruction to the Council to take steps for amendment of By-law 35 (1) (last line but one), so as to provide that the *Executive Committee(s) of the Division(s) comprised in the Constituency shall decide* whether the election of the Representative(s) is to be by General Meeting of the Constituency or by postal vote.

ARRANGEMENTS FOR ELECTION OF REPRESENTATIVES.

(By-law 35 (2).)

70. Difficulty has frequently arisen owing to the provision in By-law 35 (2) that the meeting or voting papers for election of the Representative(s) shall be called or issued "by the Secretary of one of the Divisions" (in a compound Constituency).

Recommendation.—That it be an instruction to the Council to take steps for amendment of By-law 35 (2) so as to provide that, in the case of a Constituency containing more than one Division, the meeting for election of the Representative(s) shall be called, or the voting papers issued, *by the Secretary of the largest Division*, or, failing action by him, by the Council.

NEED FOR MEETING OF CONSTITUENCY SHORTLY BEFORE A.R.M.

(By-law 35 (3) and (4).)

71. The Council considers it desirable that, in whatever manner the Representative(s) is elected (*i.e.* whether by meeting or postal vote), a meeting of the Constituency shall be held within the 28 days before the A.R.M., for consideration of the Agenda of the A.R.M. and instruction of the Representative(s).

Recommendation.—That it be an instruction to the Council to take steps for amendment of By-law 35 (3) and (4) so as to provide that a *Meeting of the Constituency shall be held within the 28 days before the A.R.M.* to consider the Agenda of the A.R.M. and instruct the Representative(s) thereon.

NOTICE OF ELECTION OF REPRESENTATIVES.

(By-law 35 (4).)

72. There is, yearly, considerable irregularity in connection with the return of the Representatives. Some Constituencies fail to elect or to notify the Head Office of the result of the election within the four, or the three,

weeks at present prescribed (By-law 35 (1) and (4)). Such returns, made or received late, are under By-law 35 (4) invalid, but the Representative Body has made a practice of accepting them. The Council considers that the **Representative Body should discontinue acceptance of late returns**, giving all concerned due previous warning that the requirements of the By-laws as to election, and notice of election, of Representatives must be complied with.

73. The Council is also of opinion that notification of result of election not less than three weeks before the A.R.M. is much too short a time. In harmony with the Recommendation contained in paragraph 68 of this Report (to the effect that the Representatives shall be elected not less than two months before the A.R.M.), the Council recommends:

Recommendation.—That it be an instruction to the Council to take steps for amendment of By-law 35 (4) so as to provide that notice of the names and addresses and mode of election of the Representatives be sent to the Head Office *not less than six weeks* before the A.R.M.

FILLING OF CASUAL VACANCY IN OFFICE OF REPRESENTATIVE.

(By-law 36 (4).)

74. By-law 36 (4), as to filling of casual vacancy in the post of Representative, is not sufficiently definite as regards notification of the result to the Head Office.

Recommendation.—That it be an instruction to the Council to take steps for amendment of By-law 36 (4), by insertion of provision that the name and address of the new Representative *shall be forwarded as soon as may be to the Head Office.*

DEPUTY-REPRESENTATIVES.

(By-law 37.)

75. The majority of the Constituencies, as a routine step, use the power given by By-law 37, adopted in 1917, to elect Deputy-Representatives for the year. The Council is glad of this, as the arrangement is more satisfactory in every way than the former plan, by which it was practically left to chance as to how, when, or if at all, a Deputy would be elected in the event of the Representative being unable or unwilling to attend a given Meeting. The Council considers that the new arrangement should be made the general and only one.

Recommendation.—That it be an instruction to the Council to take steps for amendment of By-law 37 so as to provide that, at the same time as it elects its Representative(s), each Constituency *shall elect its Deputy-Representative(s) for the year.*

CONVENING OF ANNUAL REPRESENTATIVE MEETINGS.

(By-law 38.)

76. Under the Articles and By-laws as they stand, the Council decides the place of the Annual General Meeting (Art. 17) and of the general Scientific Meetings (Art. 25), but the Annual Representative Meeting (By-law 38) decides the place of the next Annual Representative Meeting. In practice the Annual Representative Meeting and the Annual General Meeting are held at the same place, and it is desirable that this should be recognised in the By-laws. This will necessitate the Council submitting a recommendation to the Representative Body as to the place in which the Annual Representative Meeting is to be held, in view especially of the interdependence of the General, Scientific and Representative Meetings.

Recommendation.—That it be an instruction to the Council to take steps for amendment of By-law 38 ("Convening of Annual Representative Meetings"), whereby it will be the *duty of the Council to submit to the Annual Representative Meeting a recommendation as to where the next Annual Representative Meeting should be held.*

REQUISITION FOR SPECIAL REPRESENTATIVE MEETING.

(By-law 39 (1).)

77. The Council is of opinion that 7 is too small a number of Constituencies to make requisition for, and commit the Association to the expense of, a Special Representative Meeting.

Recommendation—That it be an instruction to the Council to take steps for amendment of By-law 39 (1) so as to provide that Special Representative Meetings shall be convened at any time by the Chairman of Representative Meetings on the requisition of the Council (as at present), or on the requisition of not less than 20 Constituencies.

BUSINESS OF SPECIAL REPRESENTATIVE MEETINGS.

(By-law 39 (2).)

78. The Council considers it important that there should be the utmost liberty for discussion of any subject for which a Special Representative Meeting is convened. In the light of experience, it is possible that the existing words "indicate the object," in By-law 39 (2), would be apt to prevent such free and full discussion. The Council proposes to clear the matter up with Counsel.

Recommendation.—That it be an instruction to the Council to take steps for amendment of By-law 39 (2), so as to provide that free and full discussion shall be in order, if on reference to Counsel it is found that the present wording ("indicate the object for which such Meeting is convened") would tend to prevent such discussion at a Special Representative Meeting.

ELECTION OF MEMBERS OF COUNCIL BY A.R.M.

(By-law 40.)

79. Existing By-law 40 (fifth line) is incorrect in stating, as an item of the business of the A.R.M., the election of "12 members of the Council." In point of fact, the A.R.M. elects at present 16 members of the Council, viz., 12 by the grouped Representatives and 4 by the Representatives acting together. The Council considers that By-law 40 should leave the other By-laws to state the number of members of Council to be elected by the A.R.M.

Recommendation.—That it be an instruction to the Council to take steps for amendment of By-law 40 so as to read (fifth and sixth lines) as follows:—
"to elect such members of the Council, and such other Officers" (etc., as at present).

RESOLUTIONS BY DIVISIONS AND BRANCHES FOR CONSIDERATION OF A.R.M.

(By-law 40.)

80. The Council considers that the present wording of By-law 40 (last line but seven, etc.), viz., "to consider any resolution relating to the honour and interests of the medical profession or of the Association," is unduly restricted and not as wide as is permitted by paragraph 3 of the Memorandum of Association, nor as wide as the present practice of the Association in this connection.

Recommendation.—That it be an instruction to the Council to take steps for amendment of By-law 40 (last line but seven, etc.) so as to state as part of the business of the A.R.M.:—

"... to consider any resolution relating to the promotion of the medical or allied sciences or the maintenance of the honour or interests of the medical profession or of the Association which shall" (etc., as at present).

BUSINESS OF A.R.M.

(By-law 40.)

81. There is a verbal discrepancy between Article 30 (2), as to resolutions of the Representative Body, and By-law 40 (last line but two), as to the business of the A.R.M. The Council is legally advised that it will be well to amend the By-law to tally in this respect with the Article.

Recommendation.—That it be an instruction to the Council to take steps for amendment of By-law 40, as to business of A.R.M. (last line but two), so as to read "shall have been published in the Journal . . ."

ROLL CALL: CARD VOTE.

(By-law 42 (2).)

82. Though existing By-law 42 says nothing as to it, vote by roll call is now one of the recognised methods of voting in Representative Meetings. Under that method, the names of those voting for or against a motion

or amendment are taken, and recorded in the Minutes. The method is found extremely useful, being precise, and saving the time of the Meeting, as compared with the more cumbersome method of card vote, and the Council considers that voting by roll call should be regularised by By-law. Under the S.O.s. of the Representative Body a request by 10 Representatives secures (if a vote by card is not decided on) a vote by roll call. Under existing By-law 42 (2), a request by 20 Representatives secures a vote by card. In the opinion of the Council, the number of Representatives to secure a vote by roll call should be 15, and to secure a vote by card, a request to that effect by a majority of the Representatives present should be necessary.

Recommendation.—That it be an instruction to the Council to take steps for amendment of By-law 42 (2) so as to read somewhat as follows:—

"(2) Voting shall be by show of hands, unless before such vote is taken 15 Representatives present request that the vote be taken by roll call, in which event it shall, subject as below, be so taken. If however a vote by card is requested by a majority of the Representatives present, the vote shall be by card."

(IV.) Question of Referendum on Resolutions of R.B. or of General Meeting. (Art. 31.)

83. The Council has carefully considered the motion by Plymouth, referred to the Council in Minute 160 of the A.R.M., 1919 (see para. 32 of this report). In dealing with the motion, the Council has had the help of a memorandum by the Division on the subject. The Division raises two questions in connection with the procedure on a referendum as to a resolution of the Representative Body or General Meeting, viz., (1) whether the taking of a referendum could not be expedited in various ways which the Division suggests; and (2) whether Division Secretaries should not be empowered to obtain the decision of the Division either by general meeting or postal referendum of the members of the Division.

(1) QUESTION WHETHER REFERENDUM ON RESOLUTION OF R.B. OR GENERAL MEETING COULD NOT BE CARRIED OUT MORE EXPEDITIOUSLY.

84. Under present Article 31, the steps are:—

(1) Representative Body (or General Meeting) by resolution decides a question.

(2) Council holds, within 3 months (in practice immediately after the Meeting at which the resolution is passed), a meeting to consider the resolution, generally with others (Art. 31 (a)).

(3) Council at its meeting may approve the resolution, and is held to have approved it unless half or more of the members of the Council are present and it is determined by a majority of not less than two-thirds of the votes given, that the resolution does not properly represent the wishes of the Association and that a referendum is expedient (Art. 31 (b)).

(4) (If referendum being taken) Requisition for Division meetings must be sent by Council within 8 weeks of its meeting, together with any observations the Council may think fit to make as to the resolution (Art. 31 (c)).

(5) Meeting of Division to be held within 4 weeks of receipt of Council's requisition (Art. 31 (c)).

(6) Certificate of Division Secretary as to number of votes for and against resolution has to be in hands of Council within 4 months of meeting of Council (Art. 31 (e)).

(7) Resolution is deemed "approved on a referendum" if total of votes given at the Division meetings in its favour exceeds total of votes given against (Art. 31 (e)).

(8) If Council meeting prescribed by Article 31 (a) is not held, or if requisition prescribed by Art. 31 (a) is not sent, resolution comes into operation immediately on expiration of the 3 months or the 8 weeks, as the case may be (Art. 31 (f)).

(9) Approval of the resolution by Council or on referendum has to be published forthwith in Journal (Art. 31 (g)).

85. The Plymouth Division proposes that (a) the Council meeting be held within one month (instead of three); (b)

the referendum go to the Divisions within *one* week (instead of eight) of Council's decision to take it; and (c) the Divisions should arrive at their decisions within *one* week (instead of four).

(a) *Time of Meeting of Council.*

86. The Council considers that the proposal (a) of the Division is a good one. It seems desirable that the Council should arrive at its decision while the matter is fresh in the minds of its members. The month proposed by the Plymouth Division might on occasion save valuable time. The interval was in 1903 "7 days," being altered in 1910 to the present "3 months."

(b) *Time of Issue of Referendum to Divisions.*

87. It would be impossible for the Council to refer such a matter to the Divisions within one week of its meeting, it being not at all a straightforward task to draw up and settle, in terms fair and sufficiently informative, a referendum in such a case. It would rarely or never be possible, with due regard for efficient dispatch of business, for the Council simply to send to the Divisions a bare resolution of the R.B. or General Meeting and ask them to reply "yes" or "no." In practice it is found that, to give a clear issue, it is necessary to send, with the resolution, a statement of the main facts in connection with which the resolution was passed. The Council considers that Article 31 (c) properly directs that there should go to the Divisions, with the resolution, "such observations on the subject . . . as the Council may direct," and in order that this may be adequately done, the "8 weeks" stated by Article 31 (c) is, in the opinion of the Council, an appropriate time, especially in view of the fact that the A.R.M.s, at which most decisions of the Association are taken, are ordinarily held towards the end of July, and that in the following weeks a meeting of the Council, to settle the terms of the referendum, would be with difficulty arranged, nor could satisfactory meetings of Divisions in this period be secured.

(c) *Time of consideration of Referendum by the Divisions.*

88. The Plymouth Division raises the question whether it would not be possible for the Divisions to arrive at their decisions on a referendum within *one* week of its receipt (instead of the present four). The Council considers that the present period of four weeks, found to work well in practice, is a good one. Should there be any need for greater urgency, the Council considers that arrangements can readily be made to meet the special circumstances.

Recommendation—That it be an instruction to the Council to take steps for amendment of Article 31 (a) and (f) so as to provide that the meeting of the Council to consider a resolution of the R.B., or of a General Meeting, must be held *within one month* of the passing of the resolution.

(2) QUESTION OF DIVISION SECRETARIES HAVING AN OPTION TO OBTAIN DECISION OF DIVISION ON A REFERENDUM BY GENERAL MEETING OR INDIVIDUAL POSTAL VOTE.

89. From first to last the question of adopting the plan of individual postal vote, instead of or as part of a referendum to Division meetings, has received a large amount of consideration from the Association. Invariably, the decisions have been against introduction of individual postal vote as part of the referendum, on the ground that it would be subversive of the Divisional machinery of the Association. Obviously, the best decisions are those arrived at collectively after discussion, and the Division meeting (Article 31 (c) and (d)) ensures such discussion. This applies with special force to any matter which is considered of such importance as to necessitate an appeal to the Divisions from a decision of the R.B. The Council therefore regards as inadvisable the introduction of individual postal vote as part, or possible part, of a referendum.

(V.) Council.

COMPOSITION OF COUNCIL.
(By-law 46.)

90. In the scrutiny made of the machinery of the Association special consideration has been given by the Council to the question of the composition of the Council. At present, the Council consists of members appointed as follows:—

Category	No. of Members of Council
(a) Grouped Branches and Divisions in U.K. (By-law 46 (a))	24
(b) Grouped Branches outside U.K. (By-law 46 (b))	7
(c) 12 Groups of U.K. Representatives (By-law 46 (c))	12
(d) Representatives (By-law 46 (d))	4
(e) Representative Body (By-law 46 (e))	4 Service Members)
(f) Members <i>ex-officio</i> (Article 32)	7 (President, President-Elect, Past-President, Chairmen of R.B. and of Council, Past-Chairman of Council, Treasurer)
Total	58

Thus, of the total 40 members of the Council other than the Oversea, Service and *ex-officio* members, 24 are at present elected by the votes of the individual members of the Branches in the U.K., grouped in 24 groups for the purpose, 12 by the Representatives in the Representative Body grouped in 12 groups for that purpose, and 4 by the Representatives present at the A.R.M. acting together. There is no restriction as to what members of the Association shall be elected, except that to be eligible for election in the 24-election ((a) above) or the 12-election ((c) above), the candidate must be a member of a Branch in the group (By-law 51). In practice, those elected to the Council in the 12-election are nearly always Representatives, while on the other hand in the 24-election ((a) above) it often happens that some of those elected are neither Representatives nor members of the Representative Body.

91. As the 24-grouping and the 12-grouping (which are necessarily co-ordinated the one with the other) at present stand, there has advisedly been over-representation of Ireland and, to a less extent, of Scotland. On the combined 24 and 12-groupings, as matters stand, there is one member of Council—

- Ireland (741 B.M.A. members), for each 124 members.
- Scotland (2,122 B.M.A. members), for each 353 members.
- Wales (877 B.M.A. members), for each 584 members.
- English Provinces (9,501 B.M.A. members), for each 582 members.
- Metropolitan Counties Branch (3,000 B.M.A. members), for each 500 members.

92. In the opinion of the Council the election of 12 members of the Council by 12 groups of representatives is, on various grounds, especially the fact that the electorate is often a very small one, unsatisfactory. The Council considers that existing By-law 46 (c) and (d) should be deleted, and that the 16 members of Council in question should be elected by the grouped Representatives of England, Ireland, Scotland and Wales, acting together to elect, England 12, Ireland 1, Scotland 2, and Wales 1, members of Council.

Recommendation.—That it be an instruction to the Council to take steps for amendment of By-law 46 (and other By-laws consequentially) by substituting for existing By-law 46 (c) and (d), a paragraph somewhat as follows:—

"(c) 16 by the Representatives of Constituencies present at the Annual Representative Meeting, namely, 12 by the Representatives (acting together) of the Constituencies in England; 1 by the Representatives (acting together) of the Constituencies in Ireland; 2 by the Representatives (acting together) of the Constituencies in Scotland; and 1 by the Representatives (acting together) of the Constituencies in Wales;"

existing By-law 46 (e) to become 46 (d).

Recommendation That the R.B. direct that if and when the new system of election of the Council comes into operation, the Council reconsider the proportion of members of Council to be allotted to the various parts of the United Kingdom under By-law 46 (a), and the grouping within those parts.

MEMBERS OF COUNCIL REPRESENTING OVERSEA BRANCHES.
(By-law 46 (b).)

93. The Council has postponed consideration of the question of election of members of Council by the Oversea

Branches, pending settlement of the question of possible affiliation facilities. At present (1920-21 Council), the 5,708 members of the Oversea Branches are entitled to return seven members to the Council (By-law 46 (b)), i.e. on an average one member of Council for each 815 Oversea Branch members.

QUALIFICATION FOR ELECTION AS MEMBER OF COUNCIL TO REPRESENT A BRANCH OR GROUP IN THE UNITED KINGDOM.

94. While in the opinion of the Council the present arrangement whereby there is no stipulation to the effect that membership of the R.B. shall be a condition of eligibility for election as a member of the Council, is a good one, the Council is of the opinion that members of Council should have been members of the Association for at least the three years immediately preceding the election.

Recommendation—That it be an instruction to the Council to take steps for amendment of the By-laws so as to provide that no one shall be eligible for election as a member of Council to represent a Branch or Group in the United Kingdom, unless at the time of his (or her) election *he has been a member of the Association for at least the three years immediately preceding the election.*

MEMBERS OF COUNCIL *ex officio*.

(Article 32.)

(a) PAST-CHAIRMAN OF REPRESENTATIVE MEETINGS.

95. The Council considers it important that the Past-Chairman of Representative Meetings should be *ex-officio* a member of Council for one year after the expiration of his term of office.

Recommendation—That it be an instruction to the Council to take steps for amendment of Article 32 (and By-laws consequentially) so as to provide that the *Past-Chairman of Representative Meetings shall be a member of Council ex-officio for the year immediately following his period of office as Chairman.* (See also paragraph 122).

(b) DEPUTY-CHAIRMAN OF REPRESENTATIVE MEETINGS.

96. The Council considers that it would be helpful to the work of the Association if the Deputy-Chairman of Representative Meetings, in addition to the Chairman of Representative Meetings, were a member of the Council *ex officio*. It is important that the Deputy-Chairman should, by membership of the Council during the previous twelve months, have had the opportunity of making himself familiar with the central work of the Association.

Recommendation—That it be an instruction to the Council to take steps for amendment of Article 32 so as to provide that the *Deputy-Chairman of Representative Meetings shall be a member of the Council ex officio.*

VACANCIES IN COUNCIL.

97. By-law 55 provides for the filling of casual vacancies in the Council, i.e., vacancies occurring through the resignation, etc., of a member of Council. There is no explicit provision, however, in the By-laws for the filling of a vacancy caused by default of the electing body or group.

Recommendation—That it be an instruction to the Council to take steps for insertion of a new By-law somewhat as follows:—

“In the event of a vacancy (other than a casual vacancy under By-law 55) among the elected members of the Council, the Council shall in its discretion take steps to fill such vacancy, either by an election conducted in the usual way or by itself appointing a member to fill the vacancy.”

(VI.) Committees.

98. Apart from any modification which may arise from adoption of the proposals as regards affiliation facilities, the Council has specially considered the wish expressed by the Representative Body in 1915 to widen the basis of admission to Standing Committees. On consideration of existing By-law 69, the Council is of opinion that full provision is already made therein for the admission of practically any person, whether member or non-member of the Association, as a member of such a Committee, whose work or co-operation may be considered likely to be of assistance to the Committee.

SCOTTISH, IRISH, WELSH AND DOMINIONS COMMITTEES

99. Under By-law 70 each Standing Committee except the Scottish Committee must appoint from its own number a member of Council as Chairman. Under the By-law the Scottish Committee appoints both a Chairman and a Deputy-Chairman, and either the Chairman, Deputy-Chairman or Honorary Secretary of that Committee must be a member of the Council.

In the opinion of the Council this option should also be given to the Irish, Welsh and Dominions Committees.

Recommendation—That it be an instruction to the Council to take steps for amendment of By-law 70 so as to read somewhat as follows:—

“70. Each Standing Committee, except the Scottish, Irish, Welsh, and Dominions Committees, shall appoint from its own number a member of Council as Chairman. Each Committee thus excepted shall appoint (etc. as at present).”

CASUAL VACANCIES IN COMMITTEES.

(By-law 71.)

100. The Council considers that *all* Committees (and not merely Standing Committees) should have power to fill any casual vacancy arising amongst their appointed members.

Recommendation—That it be an instruction to the Council to take steps for amendment of By-law 71 so as to provide that *each* Committee (Standing or other) shall have power to fill any casual vacancy arising amongst its appointed members.

ABSENCE FROM COMMITTEE MEETINGS.

(By-law 72.)

101. The Council considers that a member of *any* Committee or Sub-Committee (whether Standing or other) absent without good reason from three consecutive meetings of the Committee should be deemed to have resigned his or her membership thereof.

Recommendation—That it be an instruction to the Council to take steps for amendment of By-law 72 so as to provide that if an appointed member of *any* Committee or Sub-Committee shall be absent from three successive meetings of that Committee or Sub-Committee, such member shall (except in case of illness or for some reason approved by the Chairman of the Committee or Sub-Committee) be deemed to have resigned his or her membership thereof, and a casual vacancy thereupon arise.

CONSULTATION BETWEEN COMMITTEES.

(Proposed new By-law.)

102. It is not provided in the present By-laws that Committees shall have full power to consult each other. Yet circumstances often arise in which it is important that a Committee should freely consult, or make suggestions to, another Committee or Committees.

Recommendation—That it be an instruction to the Council to take steps for insertion, after existing By-law 73 or elsewhere, of a new By-law somewhat as follows:—

“Consultation between Committees.

In respect of any matter with which it is dealing, it shall be competent for any Committee to consult, report to, or make suggestions to any other Committee of the Association. Similarly, it shall be competent for any Sub-Committee to consult, report to, or make a recommendation to any other Sub-Committee of the same parent Committee.”

CO-OPTION BY STANDING COMMITTEES.

103. Only the Organisation, Science, Insurance Acts, Scottish and Irish Committees have power of co-option of members. They have used that power both in the interest of the Association and with due regard to economy in respect of travelling expenses. The Council considers that it would be to the advantage of the work of the Association if each Standing Committee had the power of co-option.

Recommendation—That it be an instruction to the Council to take steps for insertion of a new By-law, after existing By-law 69 or elsewhere, somewhat as follows:—

“Each Standing Committee shall have power to call to its assistance for special purposes persons specially qualified to assist in any branch of its reference.”

STANDING COMMITTEES.

(See Schedule to By-laws.)

(1) FINANCE COMMITTEE.

(a) *Composition.*

104. The Council being adequately represented on the Finance Committee by the Chairman of the Organisation, Journal, Science, Medico-Political, Central Ethical and Insurance Acts Committees, there is, in the opinion of the Council, no need for the Council to appoint members specially to the Finance Committee.

105. Further, the Journal Committee being adequately represented in the Finance Committee by the Chairman of the former, there is, in the opinion of the Council, no need for the appointment of additional members of the Journal Committee to the Finance Committee.

106. In point of fact, the Council considers the existing Finance Committee (possible membership 20) too large. Under the proposal of the Council the Committee would have a membership of 14.

Recommendation.—That it be an instruction to the Council to take steps for amendment of the schedule to the By-laws, as to the composition of the Finance Committee, by omission (1) of appointment of members thereto by the Council; (2) of appointment of members thereto by the Journal Committee.

(b) *Reference to Finance Committee: Question of Premises Committee.*

107. The reference to the Finance Committee needs alteration, for (1) in the case of some of the funds held in trust by the Association it is the duty of other Committees to advise as to the administration thereof; (2) the supervision of the organisation and working of the Central Office is carried out by the Office Committee; (3) the Finance Committee (not the Premises Committee, which never meets) deals with questions affecting the land and house property of the Association.

Recommendation.—That it be an instruction to the Council to take steps for amendment of the reference to the Finance Committee so as to read somewhat as follows:—

“To certify the accounts prior to their presentation to the Council; to advise on (a) the administration of any funds held in trust by the Association not administered by any other Committee and of the Superannuation Fund; (b) as to the appointment of administrators for any such Funds; (c) as to the financial bearings of any proposals involving special expenditure; and (d) as to the financial position and real estate of the Association.”

Recommendation.—That it be an instruction to the Council to take steps for omission from the schedule to the By-laws of the provision for a Premises Committee.

(2) ORGANISATION COMMITTEE.

Reference.

108. The reference to the Organisation Committee also needs alteration, for the actual work of the Committee is wider than its reference. It will, the Council considers, be well that the Organisation Committee, and not as at present (nominally) the Science Committee, shall undertake the detail of the work of the central body as regards encouraging and assisting the scientific work of the Divisions and Branches.

109. Further, the *Journal* is one important means of propaganda by the Association, and it is necessary that the fact shall have the due attention of the Journal Committee. The Council is of opinion that it would therefore be helpful as regards co-ordination and effectiveness of work if the Organisation Committee appointed a member to the Journal Committee, such member to be, ordinarily or if possible, the Chairman of the Propaganda Subcommittee of the Organisation Committee. If the principle of election by the Organisation Committee of a member of the Journal Committee is approved by the Representative Body and the By-law altered accordingly, the actual method of making the nomination can be readily and simply provided for by standing order of the Organisation Committee.

Recommendation.—That it be an instruction to the Council to take steps for amendment of the reference to the Organisation Committee so as to read somewhat as follows:—

“(a) To organise systematic endeavours to maintain and increase the membership of the Association; to make reports to other Committees and the Council accordingly; and to advise and assist Divisions and Branches in the strengthening of their organisation, including the organisation of their work for the promotion of the medical and allied sciences;

(b) To advise as to the interpretation or alteration of the existing, or the adoption of new, Regulations and By-laws; as to questions of areas of existing, or formation of new, Divisions and Branches; as to grouping for electoral purposes; and as to the Rules (other than those relating to ethical matters) of Divisions and Branches and combinations thereof;

(c) To advise as to the ordinary and supplementary grants to Branches and Divisions.”

(3) JOURNAL COMMITTEE.

(a) *Composition.*

110. It has happened occasionally that the attendance at a meeting of the Journal Committee, the elected members of which at present number only 6, *viz.*, 3 appointed by the R.B. and 3 by the Council, has been too small to permit of full justice to its work.

Recommendation.—That it be an instruction to the Council to take steps to provide that the Representative Body and Council shall each appoint 4 members, and the Organisation Committee 1 member, to the Journal Committee.

(b) *Reference.*

111. The reference to the Journal Committee should be simplified, for (1) this Committee is not responsible for all the publications of the Association; (2) the Council considers (*see* para 105) that the Journal Committee is sufficiently represented in the Finance Committee by the Chairman of the Journal Committee.

Recommendation.—That it be an instruction to the Council to take steps for amendment of the reference to the Journal Committee so as to read somewhat as follows:—

“To consider matters connected with the *Journal* and any other publications of the Association which do not come within the scope of other Committees.”

(4) SCIENCE COMMITTEE.

(a) *Composition.*

112. At present the elected members of the Science Committee (8 in number) are appointed wholly by the Council. The Council is of opinion that it would add to the efficiency of the Committee if its membership were slightly larger, and appointed in part by the Representative Body.

Recommendation.—That it be an instruction to the Council to take steps to provide that the Representative Body shall appoint 4, and the Council 6, members of the Science Committee.

(b) *Reference.*

113. The reference to the Science Committee needs alteration, for (1) this Committee is not responsible, or not responsible in chief, for assisting the Officers of Sections; (2) it is now an important part of the work of the Science Committee to provide lecturers on scientific and clinical subjects for Division and Branch meetings; (3) the Council is proposing (paras. 108-9) that the Organisation Committee shall be made responsible in connection with the scientific work of the Divisions and Branches other than the provision of lecturers at meetings thereof.

Recommendation.—That it be an instruction to the Council to take steps for amendment of the reference to the Science Committee to read somewhat as follows:—

"To advise, and when so directed, act for the Council in all matters not specifically referred to other Committees which concern the work of the Association for the promotion of the medical and allied sciences, including the conditions of award of scholarships or grants given by the Association or under trusts undertaken by the Association; the arrangement of Committees for special scientific work; the provision of lecturers on scientific and clinical subjects to the Divisions and Branches or otherwise; and all matters connected with the library and its management."

(5) "PARLIAMENTARY AND MEDICO-POLITICAL" COMMITTEE.

(a) Name of Committee.

114. The Council finds that for various reasons it would be better, as indicating more helpfully the scope of the work of the Medico-Political Committee, to call it the "Parliamentary and Medico-Political Committee."

Recommendation.—That it be an instruction to the Council to take steps for alteration of the name of the Medico-Political Committee to "Parliamentary and Medico-Political Committee."

(b) Reference.

115. The Council proposes that, with but slight modification the existing reference to the Medico-Political Committee shall apply to the "Parliamentary and Medico-Political Committee." Other Committees of the Association, e.g., the Public Health, Insurance Acts, Hospitals and Naval and Military Committees, initiate on occasion Parliamentary action in connection with their work. This practice should not in any way be interfered with.

Recommendation.—That it be an instruction to the Council to take steps to provide that the reference to the Parliamentary and Medico-Political Committee shall be somewhat as follows:—

"To deal with Parliamentary and medico-political questions, and, generally, with all matters involving the public relations of the profession, not specially referred to other Committees."

(6) PUBLIC HEALTH, INSURANCE ACTS AND HOSPITALS COMMITTEES.

116. The Council has considered the question of the existing references to the present (Standing) Public Health, Insurance Acts and Hospitals Committees, the question whether the existing (*ad hoc*) Ministry of Health Committee should be made a Standing Committee, and if so, with what reference. The fact that there is now a Ministry of Health will, it is practically certain, necessitate considerable change as regards the work of some or all of these and possibly other Committees of the Association, but the Council does not consider the matter as yet ripe for solution.

(7) INSURANCE ACTS COMMITTEES.

117. The Council recommends:—

Recommendation.—That it be an instruction to the Council to take steps for amendment of the Schedule to the By-laws as to the composition of the Insurance Acts Committee, so as to define more clearly the method of election of the 22 practitioners referred to in the second paragraph thereof.

(8) NAVAL AND MILITARY, AND (9) DOMINIONS COMMITTEES.

117A. The Council has under consideration the question of the names and composition of, and the references to, the Naval and Military and Dominions Committees.

(10) IRISH COMMITTEE.

118. The Council has postponed consideration of the question of the Irish Committee, pending settlement of the question of possible affiliation facilities.

(11) ARRANGEMENTS COMMITTEE.

119. The Council considers it important that the existing (*ad hoc*) Arrangements Committee be made a Standing

Committee, formally entrusted with the duties carried out by the existing Committee.

Recommendation.—That it be an instruction to the Council to take steps to provide for a (standing) Arrangements Committee, somewhat as follows:—

The Arrangements Committee shall consist of the Officers of the Association, together with 6 members elected by the Council and 6 members elected by the Local Committee of Management of the Annual Meeting. The duty of the Arrangements Committee shall be to consider and advise the Council as to the appointment of Officers of Sections and Readers of Addresses at the Annual Meeting, and such other matters affecting the arrangements for the Annual Meeting as shall be referred to it.

MEDICO-SOCIOLOGICAL COMMITTEE.

(See also paragraph 266).

120. There are many matters intimately affecting the public health and welfare as to which the profession has special knowledge and which can best be dealt with by a partly lay and partly medical Committee. Considering that such a Committee would complete the Medico-Sociological machinery inaugurated by the appointment of the Medico-Sociological Section of the Annual Meeting, the Council has appointed as an experiment a Medico-Sociological Committee, with the following reference:—

"To consider social and economic questions affecting the public welfare as to which the medical profession may be thought to have special knowledge; and to take such steps as may be found necessary in order to create or develop public opinion thereon. The Committee shall add to its number for special purposes representative persons specially qualified to assist in any branch of its reference."

(VII.) Officers.

CHAIRMAN OF REPRESENTATIVE MEETINGS.

(Articles 32, 36, etc.)

121. The name of this Officer is still, technically, "Chairman of Representative Meetings," but in practice the designation "Chairman of the Representative Body" is frequently used as more definite, a consideration of importance as regards dealing with bodies and persons outside the Association. As the title stands it is apt to give, and has on occasion given, to persons ignorant of the constitution of the Association, the impression that the Chairman of Representative Meetings is Chairman only while the Meetings are in session. Similarly in the case of the Deputy-Chairman of Representative Meetings.

Recommendation.—That it be an instruction to the Council to take steps for verbal amendment of Article 32, etc., so as to provide that the Chairman of Representative Meetings shall be styled "Chairman of the Representative Body," and the Deputy-Chairman of Representative Meetings, "Deputy-Chairman of the Representative Body."

PAST-CHAIRMAN OF REPRESENTATIVE MEETINGS.

(By-law 61.)

(See also paragraph 95).

122. Under Article 32 and By-law 62, the Chairman of Council is for one year after his period of office a member of the Council *ex officio* for the space of one year. In the opinion of the Council it is important that the Chairman of Representative Meetings should similarly, for one year after his period of office, be a member of the Representative Body *ex officio*.

Recommendation.—That it be an instruction to the Council to take steps to provide that the Chairman of Representative Meetings shall, during his period of office *and for one year thereafter*, be a member of the Representative Body *ex officio*.

DEPUTY-CHAIRMAN OF REPRESENTATIVE MEETINGS.

(a) Status.

(Article 36.)

123. *Pari passu* with the increase of the work of the Association, the post of Deputy-Chairman of Representative Meetings becomes more and more important. In

paragraph 96 of this Report the Council is proposing that the Deputy-Chairman of Representative Meetings be a member of the Council *ex officio*. The Council considers that it is also necessary that he should have the status of an Officer of the Association.

Recommendation.—That it be an instruction to the Council to take steps for amendment of Article 36, etc., so as to provide that the Deputy-Chairman of Representative Meetings shall be an Officer of the Association.

(b) *Election.*

(By-laws 40 and 61.)

124. If the foregoing recommendation is approved by the Representative Body, the Council proposes that consequential adjustment be made in the By-laws.

Recommendation.—That it be an instruction to the Council to take steps for amendment of Section VIII. of the By-laws ("Officers") so as to include therein as requiring to be elected annually at the Annual Representative Meeting (in addition to the Chairman of Representative Meetings as at present), the Deputy-Chairman of Representative Meetings.

CHAIRMAN OF COUNCIL.

(By-law 62.)

125. The Chairman of Council is elected by that Council from its own number, and thus may have come on to the Council in any one of various ways, e.g., have been elected by grouped Representatives, by all the Representatives acting together, etc. By-law 62 requires verbal amendment to bring it into relation with the facts.

Recommendation.—That it be an instruction to the Council to take steps for amendment of By-law 62 (sixth line) so as to read for "group of Branches" "body or bodies."

Question of Steps to be taken whereby the Association may Become in Part a Federation.

Draft "Rules" or "Memoranda" of Representative Body as to Facilities for Federation or Affiliation accordingly.

126. In its report as to the question of the steps to be taken whereby the Association may become in part a federation (*B.M.J.* Supplement, March 5th, 1921, page 56, paras. 10-12), the Council stated that it proposed, in order to carry out the instructions of the Annual Representative Meeting at Cambridge, that the Representative Body should, under draft Article 8 and By-law 10 (5) (see same Supplement), adopt "Rules," which it could modify from time to time, as to the possible privileges of a body affiliating with the Association, and as to the terms and conditions of admission to affiliation.

127. The Council now submits accordingly, for the consideration of the Conference of Oversea Representatives on July 5th, the Divisions and the Representative Body, draft "Rules" or (as Counsel prefers to call them) "Memoranda," of the Representative Body on the subject (see Appendix II).

128. While thus carrying out the instructions contained in Minute 44 of the Annual Representative Meeting, 1920, the Council desires to add that, in its opinion, it would be inadvisable to affiliate to the Association at the present time any bodies whose ordinary membership is open to other than members of the medical profession. Any such step would not, in the opinion of the Council, as matters stand, add to the strength of the Association or of the medical profession as a whole.

129. The Council recommends:—

Recommendation.—That the A.R.M. 1921, adopt, as Memoranda of the Representative Body, the Memoranda, submitted in draft by the Council, in connection with the question of corporate members and nominating bodies.

SUBSCRIPTION.

(a) *Subscription of Oversea Members.*

130. The A.R.M., 1920, raised the subscription for members in the United Kingdom to 3, and for members

outside the United Kingdom to 2 guineas. The Council has since received representations as to the question of the subscription of Oversea members, from the Australian and New Zealand Branches. Having carefully considered the financial position of the Association and the special position of the Oversea Branches, the Council is of opinion that there is a case for reduction of the subscription payable to the Association by members resident overseas, other than members of the Royal Navy, Royal Air Force, Army and Indian Medical Services, from 2 to 1½ guineas. Much of the work done by the Council for the Branches at home and for the Services has to be done in the Dominions by the Branches themselves in combination, and this necessitates the levying of special local subscriptions.

(b) *Subscription of U.K. Members retired from Practice and U.K. Members of 40 years' standing.*

131. The Annual Representative Meeting at Cambridge instructed the Council to consider the question of reduction of the subscription of members retired from practice and of members of 40 years' standing.

132. The Council is of opinion that there should be a concession as regards the subscription payable by U.K. members of not less than 10 years' standing retired from practice, and by U.K. members of 40 years' standing whether retired from practice or not; and that the finances of the Association permit of a reduced subscription in respect of such members of 2 guineas.

(c) *Subscription of Husband and Wife resident in same House in U.K.*

133. The Council has also considered the question of a reduced subscription where husband and wife are both members and living in the same house in the U.K. The Council is of opinion that a reduction, from the ordinary joint subscription of 6, to one of 4½ guineas, is desirable in such cases.

(d) *(Alternative) Draft By-law Amendments accordingly.*

134. To meet the case (i.) where the R.B. desires to give effect to the above principles in existing By-law 11, or (ii.) in By-law 12 proposed by the Council as part of the plan for securing affiliation facilities (see *B.M.J.* Supplement, March 5th, 1921, page 60), the Council submits alternative Recommendations A and B.—

Recommendation A.—That the A.R.M., 1921, amend existing By-law 11 to read as follows:—

By-law 11. (1) On and after the 1st January, 1922, the annual subscription to the Association shall be as follows:—

A. *As to Members resident in any part of the United Kingdom—*

(i.) For a Member of not less than ten years' standing who has definitely and permanently retired from the active practice of the medical profession and has signed and transmitted to the Treasurer a declaration to that effect—Two Guineas.

(ii.) For any Member of not less than forty years' standing—Two Guineas.

(iii.) For a Member admitted to membership before the expiration of two years from the date of his registration under the Medical Acts—One Guinea and a Half until the 31st December next occurring after the expiration of four years from the date of such registration.

(iv.) For two Members being a husband and his wife residing together—Four Guineas and a Half.

(v.) Except as otherwise herein provided—Three Guineas.

B. *As to Members resident outside the United Kingdom—*

(i.) For any Officer of the Royal Navy Medical Service, the Royal Air Force Medical Service, the Army Medical Service, or the Indian Medical Service—Two Guineas.

(ii.) For any other Member—One Guinea and a Half.

Provided that any Member, wherever resident, who is admitted on or after the 1st July in any year, shall pay only half his current subscription for that year.

(2) For the purposes of this By-law a Member shall be deemed to reside in that place in which his ordinary place of abode is situate at the time at which according to the Regulations his subscription is considered due.

Recommendation B.—That the A.R.M. 1921 adopt, as a By-law of the Association, the following amended form of draft By-law 12 contained in the Appendix to the report of the Council as to the question of steps whereby the Association may become in part a federation (B.M.J. Supplement, March 5th, 1921, page 60):—

By-law 12. (1) On and after the 1st January, 1922, the annual subscription to the Association shall be as follows:—

A. As to ordinary Members resident in any part of the United Kingdom—

(i.) For a Member of not less than ten years' standing who has definitely and permanently retired from the active practice of the medical profession and has signed and transmitted to the Treasurer a declaration to that effect—Two Guineas.

(ii.) For any Member of not less than forty years' standing—Two Guineas.

(iii.) For a Member admitted to membership before the expiration of two years from the date of his registration under the Medical Acts—One Guinea and a Half, until the 31st December next occurring after the expiration of four years from the date of such registration.

(iv.) For two Members being a husband and his wife residing together—Four Guineas and a Half.

(v.) Except as otherwise herein provided—Three Guineas.

B. As to ordinary Members resident outside the United Kingdom—

(i.) For any Officer of the Royal Navy Medical Service, the Royal Air Force Medical Service, the Army Medical Service, or the Indian Medical Service—Two Guineas.

(ii.) For any other Member—One Guinea and a Half.

C. As to Corporate Members and Nominated Members—

Such sum whether by way of capitation or otherwise as the Representative Body may fix in each particular case.

Provided that any Member of any class (and in the case of an ordinary Member wherever resident) admitted on or after the 1st of July in any year shall pay only half the current subscription for that year.

(2) For the purposes of this By-law an ordinary Member shall be deemed to reside in that place in which his ordinary place of abode is situate at the time at which according to the Regulations his subscription is considered due.

AMOUNTS OF GRANTS TO BRANCHES.

135. The A.R.M., 1920 (Min. 51) instructed the Council to take steps for higher payments to the Divisions by the Branches. In view of the needs of the work of the Divisions and Branches, the Council finds that the existing By-law provision for ordinary grants to Branches, viz., up to a maximum of 4s. per Branch member, is insufficient

Recommendation.—That the A.R.M. 1921 amend By-law 23 (1) so as to read, in the 3rd and 4th lines, for "four shillings," "six shillings."

MEMBERSHIP.

136. The following is a statement of the changes in the membership during 1920 (the figures for 1919 are given for comparison):—

1919		1920		
New members ..	2,276	New members ..	2,627	
Arrears paid ..	111	Paid arrears ..	346	
Withdrawn		Withdrawn		
resignations ..	5	resignations ..	52	
	2,302		3,025	
Resignations ..	301	Resignations ..	716	
Deaths ..	834	Deaths ..	328	
Arrears ..	384	Arrears ..	741	
	1,019	Expelled ..	1	
	1,373		1,786	
Increase ..	1,373	Increase ..	1,239	

(Membership, December 31st, 1919 ... 21,355
Membership, December 31st, 1920 ... 22,594)

The Council is glad to report that in spite of the increase of subscription the net membership of the Association on March 4th showed an increase of 136.

NEW DIVISIONS AND BRANCHES.

137. During the year the Council has formed a number of new Divisions and Branches, including Ealing and Lewisham Divisions of the Metropolitan Counties Branch. For the new Branches formed overseas see para. 282 of this report.

HISTORY OF THE ASSOCIATION.

138. The Council considers it highly desirable that there should be a permanent record of the work of the Association and has asked Mr. S. D. Clippingdale, F.R.C.S., to prepare a short history for publication.

PROPAGANDA LITERATURE.

139. The following new leaflets have been prepared by the Propaganda Sub-Committee. They are now available and will be sent on application:—

"How does the B.M.A. spend its Money?"

"Science and the B.M.A."

"What the B.M.A. is doing now."

"Why all Poor Law Medical Officers should join the B.M.A."

"What the Association has done in connection with the Insurance Acts."

A "Services" leaflet is in preparation.

CONSTITUENCIES FOR ELECTION OF REPRESENTATIVE BODY, 1921-22.

(a) *Home Divisions.*

140. The Council has grouped the Home Divisions for election of Representatives, 1921-22, in the same way as for 1920-21, except that the Caithness and Sutherland Division of the Northern Counties of Scotland Branch, the Ealing Division of the Metropolitan Counties Branch, and the Rotherham and Sheffield Divisions of the Yorkshire Branch, have each been made independent Constituencies.

(b) *Oversea Divisions.*

141. The Council has made each Oversea Division and Division-Branch an independent Constituency.

GROUPING OF BRANCHES FOR ELECTION OF THE COUNCIL, 1921-22.

(By-law 46 (a) and (b).)

142. Under the authority conferred upon it by the Representative Body, the Council has grouped the Branches and Constituencies for election of the Council, 1921-22, in the same manner as for 1920-21 (see B.M.J. Supplement, October 9th, 1920, page 90; and March 12th, 1921, page 72).

Science.

SCIENTIFIC WORK OF ANNUAL MEETING, 1921.

143. Guided by the experience of the very successful Meeting at Cambridge the three day sections have been limited to five, viz. Medicine, Surgery, Pathology and Bacteriology, Orthopaedics and Children's Diseases, Preventive Medicine and Industrial Diseases. It has been decided to hold six two-day sections in Oto-Rhino-Laryngology, Ophthalmology, Neurology, Venereal Diseases, Obstetrics and Gynaecology, and Physiology, Pharmacology, Therapeutics and Diabetics; whilst single day sections will be held in Ambulance and Red Cross, Dermatology, Radiology and Electro-Therapeutics, Urology, Proctology, and Medical Sociology.

B.M.A. LECTURES IN CLINICAL AND SCIENTIFIC SUBJECTS.

144. The increasing popularity of the scheme whereby the services of skilled lecturers are provided at the cost of the central funds is shown by the appended list of lectures which have been given since the A.R.M. of last year. In view of the growing demand for these lectures the Council has decided to set aside during 1921 an additional sum of £200, making a total of £400.

List of Lectures with Subjects since last A.R.M.

Lecturer's Name.	Title of Lecture.	Division or Branch.
Mr. Victor Bonney.	"Modern Methods in the Treatment of Difficult Labour."	Oxford and Reading Branch.
Dr. Robert Hutchison.	"The Diagnostic significance of Abdominal Pain in Childhood."	South Midland Branch.
Dr. W. Langdon Brown.	"The Internal Secretory Glands."	Suffolk Branch.
Dr. Henry McCormac, C.B.E.	"Some Observations on the Treatment of Syphilis."	Essex Branch.
Dr. H. Russell Andrews.	"Treatment of Uterine Fibroids."	Worcester and Hereford Branch.
Mr. A. Fleming.	"Vaccine Therapy in relation to General Practice."	Maidstone Division.
Prof. G. R. Murray.	"The Diagnosis and Treatment of the Diseases of the Endocrine Glands."	South Western Branch.
Mr. W. Sampson Handley.	"The Lines of Advance in the Surgery of the Breast."	Sheffield Division.
Major M. Sinclair, C.M.G., R.A.M.C. Do.	"Demonstration on the Treatment of Fractures." Do.	Border Counties Branch. Nottingham Division.
Mr. H. Wade, C.M.G., D.S.O.	"Modern Treatment of Fractures."	Fife Branch.
Dr. B. H. Spilbury.	"Criminal Abortion."	East York Division.
Dr. S. Alwyn Smith, O.B.E., D.S.O.	"Treatment of Fractures."	East Herts Division.
Sir Henry M. W. Gray, K.B.E., C.B., C.M.G.	"Application of the Professional Lessons of the War to Civil Work."	Northern Counties of Scotland Branch.
Sir Cuthbert S. Wallace, K.C.M.G., C.B.	"Shock."	Richmond Division.
Mr. Peter L. Daniel.	"The Differential Diagnosis of acute Abdominal conditions."	Worcester and Hereford Branch.
Mr. W. McAdam Eccles.	"The early Diagnosis of acute Abdominal affections."	City Division.
Dr. J. S. Haldane, F.R.S.	"Some recent Advances in the Physiology of Respiration, Circulation and Renal Excretion."	Edinburgh Branch.

STATE AWARD FOR SCIENTIFIC RESEARCH.

145. In 1914 the A.R.M. passed the following resolution:—

108. Resolved: That in the opinion of the Representative Body of the British Medical Association the petition of Sir Ronald Ross, K.C.B., F.R.S., to the House of Commons for remuneration for his services to the Empire in having discovered how malarial fever can be prevented, should be granted.

The Council decided subsequently that it would not press the Government to deal with the matter during the period of the war. With the return of peace conditions the Council approached the Chancellor of the Exchequer asking him to further a petition from Sir Ronald Ross to the House of Commons asking for compensation for losses in the emoluments of his profession owing to his work for the Empire in connection with malaria, citing the precedent of Jenner in support of the claim. The Chancellor of the Exchequer replied that, notwithstanding the precedent cited, it was not in accordance with modern usage for a petition of this class to be recommended to the House of Commons by the Crown on the advice of a Minister, and after reviewing the whole position he was unable to do anything. The Council thereupon addressed the Speaker of the House of Commons on the subject and asked him whether petitions could be received by him, and if not, whether he could indicate the route by which such petitions could be allowed to reach the House of Commons. The Speaker replied stating in accordance with the Standing Orders of the House that no application may be made for

a grant of public money except with the consent of the Crown. In the face of this opposition the Council came to the conclusion that no further action can usefully be taken by the Association in support of the petition of Sir Ronald Ross. The Council is co-operating with the Science Guild in efforts to find some way in which scientific inventors and discoverers may be encouraged by the State.

POST-GRADUATE MEDICAL INSTRUCTION.

146. In January the Minister of Health appointed a Committee, under the Chairmanship of the Earl of Athlone, to investigate the needs of medical practitioners and other graduates for further education in medicine in London, and to submit proposals for a practicable scheme for meeting them. The following gentlemen were asked by the Council to give evidence before this Committee:—

The President of the Association, The Rt. Hon. Sir T. Clifford Allbutt, K.C.B., LL.D., F.R.S.
Dr. C. O. Hawthorne, and
Mr. R. J. Willan, M.V.O., O.B.E.

The President's evidence was based on his wide general knowledge of, and long interest in, the subject. Dr. Hawthorne spoke as one who had much practical experience of Sir Jonathan Hutchison's Polyclinic, while Mr. Willan based his evidence on practical experience gained in connection with his successful efforts to promote post-graduate work on behalf of the Newcastle Division of the Association.

REMUNERATION OF LABORATORY AND RESEARCH WORKERS.

(a) *Whole-time.*

147. The Council has experienced difficulties in attempting to define for the purpose of advertisements submitted to the *Journal* the word "permanently" contained in the following Minute 65 of the A.R.M., 1920:—

Minute 65.—Resolved: That the minimum commencing salary of a whole-time medically qualified laboratory or research worker, who is permanently employed as such, should not be less than £500 per annum.

For instance, a laboratory worker may be permanently employed, but yet may be allowed to carry out in his employer's laboratory some private work which may be of pecuniary advantage to himself. The Council considers that Minute 65 of the A.R.M. should be so modified that the £500 minimum shall apply only to appointments which do not carry with them such advantages.

The Council recommends:—

Recommendation.—That Minute 65 of the A.R.M. 1920 be further defined as follows:—

That the minimum commencing salary of a whole-time medically qualified laboratory or research worker who is permanently and *exclusively* employed as such should not be less than £500 per annum.

(b) *Part-time.*

The Council recommends:—

Recommendation.—That those medically qualified laboratory or research workers holding part-time appointments should receive remuneration for the time engaged, at the rate of not less than £500 per annum.

THE LIBRARY.

148. The Council has considered a proposal that the Library should be made more accessible to members of the Association by making use of the Divisional machinery and has decided to try as an experiment in the South Essex Division, an arrangement whereby books from the Lending Library will be supplied to the members of the Division through the Division itself, the Division being responsible for the books. The details of the scheme are at present being worked out, and if the experiment proves a success these details will be communicated to other Divisions who may be anxious to adopt such a scheme.

149. The Council, last year, approved of a proposal whereby the Library was to remain open until 6.30 p.m. on week-days and 2.0 p.m. on Saturdays. This extension of hours has been responsible for 818 additional attendances and the Council proposes to continue the experiment for a further period of one year.

150. The catalogue of Periodical Publications in the Library is to be reprinted and brought up to date.

Medical Ethics.

PROFESSIONAL SECRECY.

151. The Council has given consideration to the following Minute 76 of the Annual Representative Meeting, 1920:—

That the Council be instructed to consider the extent to which, and the ways in which, the Association is prepared to support its members in maintaining professional secrecy.

The Council realises that there are times when public interest must prevail and over-ride the doctor's claim that information which he has obtained in a professional capacity shall not be disclosed, e.g., in a Court of Law when the Court has ruled that information of a confidential nature must be disclosed. Where a doctor refuses to obey the order of a Court in this respect the Council is of opinion that he must do so entirely on his own responsibility.

152. It appears to the Council, however, that the encroachments on professional secrecy are most likely to come from that side of Government which is concerned with the administration of the law. This tendency to encroachment has been partly in legislation and partly in judicial action. The Association had occasion not very long ago to resist with great difficulty a suggestion by the Lord Chief Justice and the Law Officers of the Crown that doctors should depart from their tradition of professional secrecy in order to aid the Law Officers in detecting the practice of abortion. The representations made by the Association were so effective that no further action has been taken in the matter, but at any time attempts may be renewed. The Council is of opinion that all such attempts should be resisted with all the means at the disposal of the Association.

153. The Council recommends:—

Recommendation.—(1) That when a medical practitioner refuses to divulge information which he has obtained in the exercise of his professional duties in such circumstances as the following:—

- (a) In a Court of Law when the Court has ruled that information so obtained must be disclosed;
- (b) where it is already provided by Act of Parliament that he must do so, for instance, in the notification of certain diseases;

such action must be taken entirely on his own responsibility and the Association cannot be expected to support him or protect him from consequences he may incur in so doing.

- (2) That if attempts be made to add additional exceptions to the general rule of the profession as regards professional secrecy, the Association recognises that it will be necessary, after consideration, (i.) to resist by all lawful means any such encroachment, and (ii.) where such encroachment is attempted, to accord support by any means in the power of the Association to any individual practitioner who may be assailed through such new encroachment.

SOUTH WALES COLLIERY MEDICAL AID SCHEMES.

154. The Council has sanctioned the insertion of eight Important Notices in respect of Workmen's Medical Schemes in the South Wales Colliery area. The Council views with great concern the extension of these Schemes and is desirous of supporting the local profession in its fight against them in every possible way. In order that the machinery of the Association may be placed promptly and fully at the disposal of the Divisions requiring it, the Council has adopted (with slight amendments) a Report of the Contract Practice Committee of the South Wales and Monmouthshire Branch, describing fully the objections, both public and professional, to Schemes formed under Section 15 (3) of the National Health Insurance Act.

IMPORTANT NOTICES.

155. During the year it has been necessary to insert several Important Notices in the *Journal* regarding Appointments the salaries attached to which did not conform to the scale laid down by the Representative Body. These Important Notices were only inserted at the request of the Divisions concerned, and in several

instances the Divisions also adopted resolutions under the Ethical Rules in relation to the appointments. The Council is glad to report that on several occasions such action had the desired result, the salary attached to the post being raised at least to the minimum recognised by the Association, and many practitioners are known to have refrained from applying for appointments after they had considered the objections to the appointments which were placed before them by the Association.

156. In order that the Important Notices may be utilised with no avoidable delay in cases where the salary of a whole-time or part-time appointment does not conform to a recognised minimum laid down by the Association, the Council has authorised the Chairman of the Central Ethical Committee to insert such Notices without waiting for the application of a Division or Branch under certain conditions. The conditions are (i.) that the salary or conditions of the appointment in question do not conform to a recognised minimum laid down by the Association, and (ii.) that the Division or Branch within whose area the appointment lies must have adopted the current rules of procedure in ethical matters. The adoption of this procedure will enable an Important Notice to be inserted promptly in cases where the delay consequent on following the present procedure, which is to wait for the initiative to be taken by the Division, might be dangerous.

Ministry of Health.

157. A Ministry of Health Committee was again appointed by the Council with a general reference to consider and report from time to time what should be represented to the Minister of Health as being the ideal system of Medical and Allied Services which would receive the support of the profession and towards which the Government should work. Representatives of the Medical Women's Federation, the Poor Law Medical Officers' Association, the Society of Medical Officers of Health and the British Dental Association were co-opted, as were all the members of the Association who are also members of the Consultative Councils in England and Wales.

REPORTS OF THE CONSULTATIVE COUNCILS OF THE MINISTRY OF HEALTH.

158. The Council in accordance with the instructions contained in Minutes 145 and 149 of the A.R.M. 1920, and after consideration of the opinion as to the Report of the Consultative Council expressed by the Meeting in Minutes 148, 149, 151-3, prepared and issued to the Divisions and Branches in October, 1920, the Memorandum (D. 4) (Appendix III. hereto) and Questions (D. 5) (Appendix IV. hereto) on the Report of the Consultative Council on Medical and Allied Services:—

Minute 145.—That the A.R.M. thanks the Ministry of Health Committee for work already undertaken and proceeds to consider the general principles contained in the Report of the English Consultative Council to the Ministry of Health; and that the whole question be submitted anew to the Divisions and thereafter considered at a Special Representative Meeting.

Minute 147.—Resolved: That the discussion on the question of the Report of the Consultative Council of the Ministry of Health be closed at 4 p.m. this afternoon; and that the matter be then referred to the Council to consider and to submit an exhaustive report to the Divisions, and to call, in due time, a Special Representative Meeting to consider this matter.

159. Division Secretaries were supplied with copies of the Reports of the English and Welsh Consultative Councils and of the summaries thereof, which had appeared in the *B.M.J.* May 29th and June 5th, 1920, and were asked to forward the replies of their Divisions to the Questions by November 15th, 1920, in view of the instruction of the A.R.M. 1920, as to the calling of a S.R.M., and the possibility of legislation early this year. Subsequently, however, the Council did not consider it necessary to incur the expenditure of calling a S.R.M. as it seemed very improbable that there would be any legislation before the A.R.M.

160. Up to January 14th, 1921, replies to the Questions were received from 127 Divisions and Branches, and a brief résumé thereof is given in Appendix V. hereto.

161. It was evident from the replies of a number of the Divisions that they had understood Question 1 as necessarily involving the establishment of a whole-time Salaried

State Medical Service, and that owing to this misapprehension some of their answers to subsequent questions had been prejudiced. It is necessary therefore to restate the question, and the Council hopes that the Divisions will give the following paragraph their careful consideration and instruct their Representatives, so that when the matter is discussed at the Representative Meeting the opinion of the Association on what is a fundamental point may be clearly elicited.

The original question was:—

“ Domiciliary Attendance.”

Should the State assume the responsibility for seeing that for every household in the land a family doctor is available? ”

162. What the Ministry of Health Committee was trying to bring out in the question was whether or not it is desirable that the State should undertake the responsibility for seeing that there is no district in the country without a practitioner who may be consulted when needed, payment for his services being made by one of the methods now in vogue:—

(1) As regards necessitous persons, by the public authority;

(2) As regards insured persons, under arrangements made by National Insurance Authorities; and

(3) As regards others, by payment of fees to the doctor himself, either by periodical contribution or on the basis of services rendered.

The question might in other words be restated as follows:—

Domiciliary Attendance.

Should the State assume responsibility for seeing that for every person requiring medical attention there should be available a general practitioner, who, however, would not necessarily be in the whole-time service of the State; whose services would only be available free of charge if the person were necessitous; and whose services should otherwise be available either on a contract or insurance arrangement, or on payment of fees?

MINISTRY OF HEALTH (MISCELLANEOUS PROVISIONS) BILL.

163. In the before-mentioned Memorandum the Council drew the attention of the Divisions to Clause 11 of the Ministry of Health (Miscellaneous Provisions) Bill, introduced into the House of Commons on August 16th last. That clause proposed to give the Councils of Counties and County Boroughs power (already possessed, but rarely exercised, by urban and rural sanitary authorities under the 1875 Public Health Act) to supply and maintain hospitals (including out-patient departments) of a general or special character; to contribute on terms and conditions to be approved by the Minister of Health to any voluntary hospital or similar institution in their area; and to maintain any poor law hospital or infirmary in their area.

164. The Council immediately made representations to the Minister of Health that there should be such amendments made to the Bill, and to the 1875 Public Health Act, as would require all local authorities to obtain the sanction of the Ministry of Health to their proposals before exercising any of their powers thereunder. It was felt that before such powers were conferred at all, it was essential that the conditions under which patients could be received into such aided or maintained hospitals, and the terms and conditions of the appointment of the staffs of such hospitals, should be made the subject of consultation with the profession. Dr. Addison was reminded that the Report of the Medical Consultative Council pointed out that “ many hospitals schemes are likely to be defective because their promoters fail to realise that a modern hospital should be part of a more comprehensive organisation.”

165. The Minister of Health thereupon invited a deputation to meet him and it did so on November 1st, 1920, the proceedings being fully reported in the *B.M.J.* Supplement of November 6th, 1920. It will be seen from that report that the Minister accepted the suggestions of the Association as regards the above Bill; agreed that on questions affecting the profession there should be consultation with it, and raised the question of a central committee representative of the medical profession which he could consult on questions of health legislation. The Bill was dropped, but as will be noted from references in the Hospitals section of this report the hospital problems which it was intended to deal with still remain and have caused much anxiety.

LOCAL MEDICAL ADVISORY COMMITTEE.

166. The possibility of general action by local health authorities on the lines of the suggestions in the Report of the Consultative Council, together with sporadic action such as has taken place at Bradford (*see* para. 255), has raised the question whether Local Medical Advisory Committees should be set up in anticipation of any legislation so as to be ready to be consulted by any Local Authority, or to press its views unasked on any such Authority as was taking steps likely to prejudice the interests of the profession locally. The necessity of such a Committee, representative of the whole profession, has been recognised by the Representative Body, which was, however, then contemplating that the Committee would be a statutory body. Pending the setting up of a Statutory Local Medical Advisory Committee it is a question whether the profession should elect such a Committee or should press for the recognition of the local Division or Branch of the B.M.A. when the area of that Division or Branch is approximately coterminous with that of the Local Authority. The matter is receiving the attention of the Council.

Proposed Central Medical Committee Representative of the Profession as a whole to consult with the Minister of Health on Questions of Policy affecting the Profession.

167. When, as mentioned in para. 165, a deputation from the Association waited upon the Minister of Health in regard to certain clauses in the Ministry of Health (Miscellaneous Provisions) Bill, after agreeing to accept, in the main, the suggestions brought forward by the deputation, Dr. Addison spoke at length in regard to a request made for consultation with the profession on the general policy of utilising the Poor Law Institutions for general hospital purposes. He said:—

“ On several occasions I have said in public ‘ If you want us to consult you, get busy and set up machinery whereby you can readily be consulted.’ I quite agree as to the reasonableness of consultation in the formative stages regarding regulations or conditions, or general principles, if some machinery for consultation were available, but I will not consult half a dozen different bodies, each claiming to represent the profession. No body of medical men is more competent than those before me to-day to state a case for the profession, and I should be very glad to see them in consultation. I am speaking now, of course, of consultation with an exterior body, in respect of the profession generally. I am leaving out of account for the moment the Consultative Council, which is now a part of the machinery of the Ministry. As soon as practicable, I, or an officer acting on my behalf, will be willing to discuss the general principles with some body representing the profession. I can imagine no organisation better qualified than the British Medical Association to get together a representative body, but I repeat that I am not going to make an agreement of this kind with a number of different bodies, each claiming to be representative.”

168. Subsequently the following correspondence took place between the Chairman of Council and Dr. Addison:—

“ Ministry of Health,

“ Whitehall, S.W.1.

“ November 26th, 1920.

“ Dear Professor Bolam,

“ You will remember that at the deputation from the British Medical Association which met me on the 1st instant, the question of consultations with the profession was discussed, and I stated that I was quite ready to agree to consult a representative body on questions of policy affecting practitioners, but that I could not undertake to consult all the various bodies which now claim a representative character. The difficulty is how to secure the appointment of a body which will be recognised not only by practitioners of all classes, but by the various existing organisations as expressing the views of all sections of the profession. It is, of course, not for me to make any suggestions as to how such a body might be, or ought to be, constituted. But I am satisfied that it will be impossible to secure the constitution of a representative body without the good offices of the British Medical Association in bringing them

together, and if your Council have not already done so, I would suggest that you should now initiate action to secure the appointment of a body whose credentials will be incontestable.

"Yours truly,
(Signed) CHRISTOPHER ADDISON."

"3, Queen's Square,
"Saville Row,
"Newcastle-on-Tyne.
"November 29th, 1920.

"Dear Dr. Addison.

"I am much obliged for your letter of the 26th instant.

"We took at once certain preliminary steps to secure a representative body, such as you kindly agreed to consult. The difficulties of satisfying all interests concerned are so great that one is bound to proceed cautiously in order to avoid jeopardising the successful result of negotiations. The matter was placed before our Ministry of Health Committee, and we have appointed a small Committee, consisting of the Officers of the Association, viz.: Sir T. Clifford Allbutt, Dr. T. W. H. Garstang, Dr. R. A. Bolam, Dr. G. E. Haslip, the Chairmen of the following standing Committees:—

"Ministry of Health Committee (Mr. E. B. Turner);

"Public Health Committee (Dr. T. Ridley Bailey);

"Insurance Acts Committee (Dr. H. B. Brackenbury);

"Hospitals Committee (Mr. N. Bishop Harman); together with Lord Dawson, Sir Malcolm Morris, K.C.V.O., and Dr. Ewen J. Maclean, Cardiff.

"The reference to this Committee was to consider and make a recommendation to the Council as to the suggested personnel of a representative body to consult yourself on questions of policy affecting practitioners. The meeting of this Committee is arranged for the 8th prox., in order to report to Council, which meets on 15th December.

"On behalf of the Council, I would wish to assure you that we are fully alive to the importance of obtaining, if possible, a body whose credentials, as you say, shall be incontestable in regard to its representative character. No effort will be spared on our part to reconcile conflicting interests, and attain that most desirable end.

"Yours sincerely,

(Signed) R. A. BOLAM."

(Note.—Sir Malcolm Morris declined to serve, and Dr. Gordon Dill was appointed in his stead.)

169. In December, 1920, the Council expressed the view that the B.M.A. itself adequately represents the views of the profession, by reason of the facts (1) that the Association contains a majority of the members of the profession, and, so far as is known, this is approximately true of every section of the profession; (2) that on the Committees of the Association dealing with Medico-Political matters there are representatives of other important medical societies officially nominated by them; (3) that the Insurance Acts Committee contains a majority of members directly elected by the Panel Committees of the country and so is representative of insurance practitioners, whether members of the B.M.A. or not.

170. The Council nevertheless was prepared to assist in establishing a Joint Representative Committee on which those Medical Corporations, Societies, or Committees with which the Association has been accustomed to work shall be invited to appoint representatives in due proportion, this Joint Representative Committee, if established, being empowered to confer with any other medical society not represented on the Joint Representative Committee before making representations to the Ministry of Health on behalf of the profession on any matter.

171. Preliminary negotiations for the establishment of such a Representative Committee were entrusted by the Council to an *ad hoc* Committee consisting of the Officers of the Association, together with Dr. J. A. Macdonald, Sir Jenner Verall, Dr. H. B. Brackenbury, and Dr. Ewen J. Maclean, to consider the position thus created, and to ascertain whether or not the Scottish Committee desired

that it should be represented on the proposed Committee. That Committee was of opinion that it should be represented.

172. The Council has communicated with the Society of Medical Officers of Health, the Medical Women's Federation, the Poor Law Medical Officers' Association of England and Wales, the Medico-Psychological Association, and the Association of Certifying Factory Surgeons, informing them of what had transpired, and asking them if they would be willing to co-operate with the Association in forming a body which could be suggested to the Minister of Health as providing him with the representative medical body which he had asked for.

173. It was left to the Chairman of Council to take action in communicating to the Royal Colleges the fact that the Association is in touch with certain medical bodies with which it has worked in the past, and that when relationship has been established with these bodies as regards the proposed new Committee, it is the intention of the Association to approach the Royal Colleges with a view of ascertaining under what conditions their co-operation could be secured.

174. Meanwhile the Council was called upon to deal with the proposal that another body should take the initiative in forming the body suggested by Dr. Addison. The communication and Memorandum enclosed therewith (Appendix VI.) were received from the Federation of Medical and Allied Societies inviting the Association, together with other bodies, to appoint three representatives to attend a private Conference upon the subject of a Central Representative Medical Committee on February 1st.

175. In view of the previous decisions of the Representative Body and Council upon the question of co-operation with the Federation, the Federation was informed that the Association regretted that it was unable to accept the invitation of the Federation to the Conference on February 1st, because the Minister of Health, in a letter dated November 26th, 1920, had asked the British Medical Association itself to "initiate action to secure the appointment of a body whose credentials will be incontestable," and the Association was engaged in trying to constitute such a body.

176. With a view of securing that the Association's point of view shall be known to all concerned the appended Memorandum (Appendix VII. hereto) was forwarded to (i.) the Minister of Health, (ii.) the various persons and bodies signing the above invitation of the Federation, (iii.) the Royal Colleges and other Societies invited to the Conference, and was published in the B.M.J. of 19th February.

177. The present position is that the Society of Medical Officers of Health, the Poor Law Medical Officers' Association, and the Association of Certifying Factory Surgeons have agreed to co-operate in the formation of the proposed Committee. The Medical Women's Federation is discussing the matter at its next Council meeting to be held in May. The Medico-Psychological Association has stated that it would be glad to co-operate with the British Medical Association through the Federation of Medical and Allied Societies in all matters and questions to be considered by the Ministry of Health.

Medico-Political.

FEE FOR NOTIFICATION OF INFECTIOUS DISEASES.

178. The Council, after careful consideration of Minute 160 of the A.R.M., 1920, which instructed the Council to press for the raising of the fee for notification of infectious diseases to 5s., came to the conclusion that it would be unwise to press the Government to increase this fee at the present time, and has concentrated its attention on trying to hasten the time when the old fee of 2s. 6d. shall be restored.

The A.R.M. 1920 also passed the following Minute 159:—

That the Representative Meeting instruct the Council to press for the immediate reversion to the 2s. 6d. fee for the notification of infectious diseases.

The 2s. 6d. fee for notification of infectious diseases was reduced to 1s. by Clauses 5 (2) and 24 (2) of the Local Government (Emergency Provisions) Act, 1916, and it cannot be restored except by (a) a special Act of Parliament, or (b) the official declaration of the end of the war. The Council has found no encouragement from any source for the suggestion that a special Act of Parliament should be demanded for the purpose of restoring the fee. Its efforts to hasten the official declara-

tion of the end of the war have been fruitless, because it is evident that many things of great national importance will be affected by that declaration. The matter has been pressed on the attention of the Ministry of Health by letters and on the notice of Parliament by questions and by an attempt to include a clause in the Ministry of Health (Miscellaneous Provisions) Bill, but all without effect. Judging by the latest statements by Ministers on this subject, the declaration of the end of the war cannot be long delayed, and we have the promise of the Ministry of Health stated in their circular to Local Authorities in December, 1919, that the fee will at once revert to 2s. 6d.

179. The Council urged the Minister of Health to take the necessary steps to give effect to the following Minute 162 of the A.R.M. 1920:—

That all necessary postage on notifications should be prepaid by the Authority responsible.

but the Ministry replied that it had no power to authorise or require local authorities to prepay postage on these forms, which by Statute are supplied free of charge to medical practitioners.

GAS LIGHT AND COKE COMPANY'S EMPLOYEES' BENEFIT SOCIETY.

180. The Council is pleased to report action which has resulted in a very substantial increase in the remuneration of the Medical Officers of the Gas Light and Coke Company's Employees' Benefit Society. When these negotiations were commenced, the Society was paying its Medical Officers 7s. 6d. per annum per family to include all the dependants. With very considerable difficulty the Council induced the Medical Officers to take combined action, and they are now receiving 21s. per family, together with several other concessions desired by them.

VICTORIA (AUSTRALIA) FRIENDLY SOCIETY APPOINTMENTS.

181. For many years the B.M.A. in Australia has been fighting the Friendly Societies for improved terms for medical contract work, and a uniform form of agreement between the Lodges and the doctors. An important Notice was first inserted on June 27th, 1914. The fight came to a climax on 21st May, 1919, when the Victorian Branch asked for the help of the Council in preventing the proposed importation of medical men from England. The "Important Notice" in the *B.M.J.* was continued, and advertisements were inserted in some of the most important newspapers in England, Scotland and Ireland, requesting doctors to apply for information before accepting any appointment connected with the Friendly Societies in Victoria, Australia. The Societies sent a representative to the United Kingdom to obtain medical practitioners, but their efforts were frustrated, for a report has since been received from the Secretary of the Victorian Branch stating that only four doctors were obtained from England, and that as a result of the action taken by the Association eleven of the fifteen Societies concerned have come into line with the policy of the B.M.A. The Victorian Branch has expressed its cordial thanks to the Council for the help thus given. The incident is very gratifying, not only because of the success of the action of the Association, but because it affords a concrete example of the advantages which our Oversea Branches may derive from their connection with the Association.

FEES FOR TRINITY HOUSE SURGEONS.

182. As a result of negotiations with Trinity House, the Elder Brethren have agreed to pay their M.O.s a 13s. capitation fee, as against a pre-war fee of 8s. for attendance on their employees, including the provision of medicines.

M.A.B. AND BONUSES FOR MEDICAL WOMEN.

183. As a result of negotiations by the Association and the Medical Women's Federation, the Metropolitan Asylums Board has granted the same war bonus to its women doctors as to the men, though previously they have made a difference between the two sexes. The Medical Women's Federation has thanked the Association for its help.

TAXATION OF MOTOR CARS.

184. The Council reports (i.) that the gist of Minute 178 of the A.R.M. 1920 (*i.e.*, that the fairest way to tax motor locomotion was by way of a tax on motor spirit)

was forwarded to the Minister of Transport on 16th July, 1920, and the attention of Sir William Joynson-Hicks, M.P., was also drawn to it; (ii.) that by invitation of Sir William Joynson-Hicks, the Chairman and Deputy Medical Secretary attended a deputation to the Minister of Transport on 18th June, 1920; (iii.) that representatives of the motor industry who were present were chiefly concerned in proving that the industry was in favour of a spirit tax of 1½d. per gallon as against the Government's proposed horse-power tax; and (iv.) that the Minister undertook to consider the facts and figures placed before him, and stated that it was a matter of indifference to him how the tax was levied so long as it produced the necessary 8½ to 8½ millions. The Government eventually decided to stand by its horse-power standard and definitely refused to make any rebates to any classes, whether commercial or professional. The Council has decided to co-operate with the Automobile Association and Motor Union in its efforts to obtain the substitution of a petrol tax for the present horse-power tax.

CENTRAL EMERGENCY FUND.

185. This voluntary fund was created by the Council in 1905 to assist members of the profession in maintaining their interests against organised bodies of the community. It is a Trust Fund and therefore not subject to any of the restrictions placed on the funds of the Association by Company Law. For some time no grants have been made from the fund, but past experience has shown how useful it can be in enabling individuals to face the financial difficulties which may be incurred by them when standing out for the policy recommended by the Association. The Council urges members to keep the fund well supported as need for it will certainly arise before long. An audited statement of the fund appears amongst the financial statements in this Report.

REPORT OF DEPARTMENTAL COMMITTEE ON WORKMEN'S COMPENSATION.

186. The Council has had before it (a) an analysis (as far as the recommendations affect the medical aspect of the Act) of the Report of the Departmental Committee appointed by the Home Office to inquire into the working of the present system of the payment of compensation to workmen for injuries sustained in the course of employment; and (b) a comparison of these recommendations with those of the Association as placed before the Departmental Committee. Further action is being reserved until legislation is introduced.

FEES FOR MEDICAL REFEREES UNDER WORKMEN'S COMPENSATION ACT.

187. The Council drew the attention of the Treasury to the fees which were fixed by the Treasury in 1907 for Referees under the Workmen's Compensation Act, and urged that they should be increased by 50 per cent.

To this the Home Secretary replied that he was not satisfied that any general revision of fees was necessary, and that the all-round increase proposed by the Association involving a substantial addition to public expenditure could not be entertained, especially in the present financial situation, unless the case for it were clearly established. The Council realises that the present time is probably as bad a time as could be selected for pressing such claims on the Treasury, and has decided not to press this matter further until a more suitable occasion.

FEES FOR MEDICAL EXAMINATION FOR LIFE INSURANCE.

188. The scale of fees set out in Minutes 119, 124, 128-30 of the A.R.M. 1920, has been accepted by the Insurance Companies represented by (a) the Life Offices' Association, and (b) the Association of Industrial Assurance Companies and collecting Friendly Societies. On the suggestion of the Life Offices' Association it has also been agreed that in the case of Industrial Offices which issue policies in their Ordinary Branches for £50 and under, if the 5s. form of examiner is used a fee of 5s. will be paid to the medical examiner; and if the 10s. 6d. form is used the fee will be 10s. 6d. The agreement has been loyally supported by both the Insurance Companies and the members of the Association, with exceedingly few exceptions.

MINIMUM SCALE OF FEES FOR PUBLIC DENTAL OFFICERS.

180. At the request of the British Dental Association for assistance in its efforts to carry into effect a scale of minimum salaries for Public Dental Officers, the Council has decided that advertisements offering a salary less than £500 per annum for whole-time single-handed Dental Officers, and advertisements offering less than £450 per annum for Assistant Dental Officers, shall not be inserted in the *B.M.J.*

VACCINATION.

190. The Council, acting on instructions contained in Minute 194 of the A.R.M. 1920, sent letters to the Ministry of Health of England and the Board of Health, Scotland, stating that in the opinion of the Association a session for vaccination should be limited to 2½ hours; that the fee for medical practitioners serving should be not less than £2 2s. per session; and that for whole-time service in performing vaccination the fee should be not less than £12 12s. per week. Only acknowledgments have been received.

POST OFFICE MEDICAL OFFICERS.

191. Continued efforts have been made by the Council to obtain recognition of the Association by the Postmaster-General as the mouthpiece of Post Office Medical Officers. This he has persistently refused to grant as he looks upon the Association of British Postal Medical Officers as the official body. As the Council knows that the number of Postal Medical Officers in the B.M.A. far exceeds those in the other Association it intends to pursue the matter if the Postal Medical Officer members of the B.M.A. will authorise it so to do. The Council has therefore issued a letter to all members who are Post Office Medical Officers asking them to state if they desire that pressure should be brought to bear on the P.M.G. with a view to obtaining his recognition of the B.M.A. as the body representative of Postal Medical Officers. Of the 1,411 members to whom this letter was issued, 814 have agreed to the proposed action of the B.M.A. and 18 have disagreed. A further letter is being sent to the 579 P.O.M.Os. who have not replied to the first letter.

FEES FOR MEDICAL PRACTITIONERS CALLED IN BY THE POLICE.

192. Pursuant to the following Minute 161 of the A.R.M. 1920:—

That fees for Police Calls should be:—Day Call, 7s. 6d.; Night Call, 10s. 6d.,

the Council considered the subject and, finding that these fees are settled locally and not by any central authority, issued a circular to all Divisions in the United Kingdom asking them to take steps locally to obtain the fees laid down in the Minute of the A.R.M., and failing that, to press for at least a 50 per cent. increase on the local pre-war fees. A number of Divisions have reported successful action in this matter.

GOVERNMENT COMMITTEE ON BLINDNESS.

193. Information having been received that evidence was to be taken by the Government Committee on Blindness, on the connection between industrial disease and blindness, the Council considered that this was a favourable opportunity to put forward witnesses who would speak *inter alia* as to the false economy of the Government in suppressing the reports of certifying factory surgeons on accidents. On 22nd March, 1921, Dr. W. F. Dearden (Honorary Secretary, Association of Certifying Factory Surgeons) and Dr. Percival J. Hay, Senior Ophthalmic Surgeon, Royal Hospital, Sheffield, gave evidence before the Committee.

FEES FOR MEDICAL PRACTITIONERS ATTENDING COURTS MARTIAL.

194. The Council, after consideration of the fees payable under Army Council Instruction 279 of 1920, to medical practitioners subpoenaed to attend Courts Martial: (viz. £2 2s. per diem for giving evidence and third class return railway fare, unless otherwise specially allowed by the Court), informed the War Office that it was of opinion (i) that Medical Officers should be placed in the same position as Army Officers when travelling, and allowed first class return railway fare; and (ii) that the fee for medical practitioners giving evidence at Courts Martial should be increased by 50 per cent. The Council is glad

to be able to report that these fees have, as from 4th May, 1920, been increased by 50 per cent. The Court now has authority to grant first class fares at its discretion.

UNEMPLOYMENT INSURANCE ACT, 1920.

195. The following rulings under the Unemployment Insurance Act, 1920, have been given by the Minister of Labour, to whom representations have been made by the Association with regard to persons employed by doctors:—

- (i.) That a domestic servant (in the employ of a medical practitioner), part of whose duties is to answer the door to patients "is not . . . an employed person within the meaning of the said Act;"
- (ii.) that doctors' coachmen and chauffeurs are employed persons within the meaning of the Act; and
- (iii.) that a medicine boy, who also acts as a messenger and cleaner of a surgery which is separate, but attached to the doctor's house, is an employed person within the meaning of the Act.

DEATH CERTIFICATION AND CORONERS' LAW.

196. On 3rd August, 1920, the Home Secretary and the Minister of Health received a deputation from the Association on the above matters. A full report of the deputation was published in the Supplement of 14th August, 1920 (p. 62), from which it will be seen that the main points raised were (a) dissatisfaction with the present form of death certificate, which made it possible for a doctor to certify death without having seen the dead body; (b) that it was objectionable that the paper certifying the cause of death should be handed to relatives of the deceased; (c) that there should be a dual certificate, one part stating the fact of death, to be given to the relatives, and the other part stating cause of death to be sent to the proper authorities; (d) that reform was needed with regard to the issue of burial orders, the registrar being entitled at present to issue such a certificate on information only, and could take a statement from any unqualified person, or relatives; (e) that there was need for legislation to govern the action of Coroners in investigating causes of death following accidents, and to prohibit riders by juries making remarks about people who were not present to defend themselves; (f) that reform was necessary with regard to identifying bodies; (g) that a fee should be provided for signing death certificates; (h) that a doctor should be entitled to a fee for giving evidence which might obviate the necessity for an inquest; (i) that a Resident M.O. of an institution who is called upon to give evidence at an inquest on a person who died in the institution should be paid for his attendance; and (j) that a fee of £1 1s. for a post-mortem examination was inadequate.

The Home Secretary and the Minister of Health both stated by letter that the points raised by the Association were receiving careful consideration, but no further information has been obtained. The questions are to be discussed with the Medical Parliamentary Committee at an early date, but it is understood that the probability of securing legislation this year is small.

SALARIES AND SUPERANNUATION OF PROFESSORS AND TEACHERS.

197. Pursuant to Minutes 65, 66 and 68 of the A.R.M. 1920, the Council has considered the question of the adoption of scales of salaries for members of the medical profession who are professors or teachers at Universities or Teaching Colleges, and makes the following recommendations in connection therewith:—

Relatively Higher Rate of Salaries of Medical, as Compared with Other Teachers.

Recommendation.—That in view of the longer period required for the education of a medical practitioner, as compared with other professions, the salaries of Medical Professors, Teachers, or Laboratory Workers should be at a higher rate than for other professions.

Non-Professorial Staff.

Recommendation.—That the essentially whole-time Non-Professorial Medical Teaching Staff should be divided into three grades as defined below, and with salaries as stated:—

Grade III.—Comprising those who are junior workers temporarily employed on probation; no person shall remain in Grade III. for more than two years.

That the minimum salaries for Grade III. be as follows:—

1st year	£300
2nd "	£350

Grade II.—Comprising Laboratory or Research Workers, or Teachers, who are permanently and exclusively employed as such.

That in accordance with Minute 65 of A.R.M. 1920, the minimum commencing salary for Grade II. shall be £500 per annum and that the full scale of this grade shall be as follows:—

1st year	£500
2nd "	£550
3rd "	£600
4th "	£650
5th "	£700
6th "	£750

and that this scale should not preclude a further increase in salary when circumstances render it desirable.

Grade I.—Comprising those of Grade II. whose qualifications or duties justify a position of seniority in status and a higher remuneration.

That the minimum salaries for Grade I. be as follows:—

1st year	£750
2nd "	£800
3rd "	£850
4th "	£900
5th "	£950
6th "	£1,000

and that this scale should not preclude a further increase in salary when circumstances render it desirable.

That after the probationary period (*i.e.*, Grade III.) has been completed, dismissal should only be possible on grounds of neglect of duty, improper conduct, or incapacity.

Professorial Staff.

Recommendation.—That the minimum salary for Professors who are permanently and exclusively employed as such should be £1,500 p.a.; the more important Chairs carrying considerably higher remuneration.

MEDICAL CERTIFICATES OF INABILITY TO ATTEND SCHOOL.

198. Pursuant to Minute 156 of A.R.M. 1920, the Education Authorities in England and Wales (326) have been informed that the Association is of opinion that where an elementary school authority requires a medical certificate of the inability of a child to attend school, the fee for such certificate should be paid by the Education Authority. The Education Authorities have also been informed that the Association is of opinion that a form of certificate should be provided for use in cases where the school attendance officer or other representative of the local education authority requires a certificate to be furnished. Up to 30th March, 1921, 53 replies had been received, of which (a) 21 stated that the matter should receive attention; (b) 9 stated that the onus for provision of certificates was on the parents; (c) 7 that they provide a certificate and pay for it, 1s. being the usual fee; (d) 2 were not in sympathy; (e) 8 were taking no action; (f) 2 asked what the fee should be; (g) 4 provide a School M.O. from whom certificates are obtained free of charge. The Scottish and Irish Medical Secretaries have been asked for their remarks on how this matter should be dealt with in Scotland and Ireland.

FEES AND TRAVELLING ALLOWANCES FOR MEDICAL WITNESSES.

199. Minutes 158 and 180 of the A.R.M. 1920, stated (i.) that the fees for medical witnesses should be 3 guineas for giving evidence at Assizes, County Courts,

and Petty Sessions, and 2 guineas in addition as a qualifying fee, and (ii.) that the Council should endeavour to obtain increased travelling allowances for medical witnesses, particularly where a journey by motor car is necessary. The Council reports that, after full consideration, whilst not considering the fees and travelling allowances to medical witnesses satisfactory, it is of opinion that the time is not opportune to apply for a further increase. As a result of representations made last session (as reported to the A.R.M. 1920) the allowances to medical witnesses in criminal cases were increased by 50 per cent. as from 25th March, 1920.

TRAVELLING ALLOWANCES OF PRACTITIONERS ATTENDING CORONERS' INQUESTS.

200. All County Councils in England and Wales (62) have been asked to grant travelling allowances to medical practitioners when attending coroners' inquests, and 27 replies have been received, of which 21 stated that the matter would receive attention; 4 gave details of travelling expenses which they are actually paying; and 2 asked for further information.

MEDICAL ATTENDANCE ON MINERS' AND OTHER WORKERS' FAMILIES.

201. Pursuant to Minutes 111 112 of the A.R.M. 1920, the question of the establishment of a minimum uniform contract practice rate for the dependants of miners and other workers throughout the United Kingdom has been considered, and the Council has come to the conclusions (i.) that it is impossible to establish a minimum uniform contract practice rate throughout the United Kingdom, and (ii.) that it is desirable, where possible, that minimum uniform rates should be established for areas in which conditions are approximately the same. The conditions both economic and social vary considerably from area to area, and so do the desire and capacity of the medical profession for organisation with a view to improvement of conditions. The Council believes that most good can be done by first trying to establish an ideal of what contract practice in the industrial areas should be, and secondly by pressing the better organised areas to try to get the model system adopted locally, in the hope that the more backward areas will gradually follow. Wales and Monmouthshire are not included in this scheme because many areas are paid by the poundage system and it is thought best, at first, to deal with the commoner capitation system, leaving Wales to be dealt with later.

202. The Council has accordingly instructed the Medico-Political Committee to draw up and submit to the Division for consideration, a model scheme embodying the conditions of service and the method and amount of remuneration for attendance on miners' and other workers' dependants in England (Monmouthshire for this purpose being excluded), as outlined below —

(i.) Free choice of doctor by patient and of patient by doctor;

It may be thought that as "free choice" is so essential a part of the creed of the Association as applied to contract work it is hardly necessary to emphasise it. As a matter of fact, however, there are still areas where doctors, by trying to preserve monopolies, are greatly hampering the struggle for better conditions. The Council is of opinion that it is impossible to organise a strong movement for improvement of remuneration and other conditions unless the workmen are promised free choice of all the doctors in the neighbourhood who are willing to do that kind of work.

(ii.) Weekly deductions to be made at the colliery or works office and disbursed direct to doctors without intervention of any Committee;

(iii.) That a Joint Committee should be set up to consider questions arising as to conditions of service;

(iv.) That as the conditions of service will be less onerous than conditions under the National Insurance Act, the remuneration should not be on the same scale, but should in no case be less than 4½d. per week if paid by all workers, married or unmarried, or 9d. per week, if paid by married men (including unmarried men with dependants) only; and

(v.) That as it is realised that the conditions in certain areas may not allow of the above terms being obtained, the approval of the Council may be given

provisionally to a scheme involving a less payment when the local Division can show that the conditions in the area demand it.

FEES FOR MEDICAL PRACTITIONERS CALLED IN ON THE ADVICE OF MIDWIVES.

203. After a very careful review of all the circumstances the Council reports to the A.R.M. that it considers it inadvisable to suggest any alteration of the definition of day and night visits in connection with the fees paid to medical practitioners called in on the advice of midwives, as suggested in the following Minute 173 of the A.R.M. 1920:

Minute 173—Resolved: That it be referred to the Council to consider whether the definition of day and night visits in connection with the question of the fees for medical practitioners called in on the advice of midwives should be amended to read as follows:—

Day (9 a.m. to 6 p.m.) 5s.

Night (6 p.m. to 9 a.m.) 10s.

Day visits are at present defined as from 9 a.m. to 8 p.m. and night visits as from 8 p.m. to 9 a.m., and as this adjustment is only of comparatively recent date (the periods formerly having been 12 hours for day and 12 for night), the Council does not advise any attempt at the present time to alter the arrangement.

TASMANIAN MEDICAL ACT.

204. Pursuant to Minute 221 of the A.R.M. 1920, a joint meeting of the Hospitals, Medico-Political and Dominions Committees, together with the Australasian Representatives, was held at Cambridge on July 1st, 1920, to consider what action, if any, could be taken with reference to the grave situation which had arisen in Tasmania owing to the passing into law of a Medical Act which (i.) made it an offence, with heavy penalties, for any registered medical practitioner to refuse or fail to meet in consultation any other registered medical practitioner; and (ii.) also made it an offence for any person or association to prevent, or attempt to prevent, directly or indirectly, any medical practitioner from accepting an appointment to a state-aided hospital. These provisions were the outcome of resignations of members of the Honorary Staffs of Hospitals in Tasmania, owing to the fact that the Tasmanian Government insisted upon their attending rich and poor alike gratuitously in hospitals. Certain suggestions were made at the Conference, and the Council has adopted such as seemed to be advisable.

205. The Council ascertained that the G.M.C. had been informed by the Colonial Office (a) that the Tasmanian Government was satisfied that this legislation had accomplished what it was intended to do, viz., that medical practitioners could, if they so desired, under the protection of the law, consult with any other medical practitioner; (b) that without this protection no member of the B.M.A. dared consult with practitioners outside that organisation; and (c) that, apart from this, there was the more important principle that in the case of life and death, and unless there was some valid reason, no medical practitioner should be permitted to refuse to consult with another who was attempting to save life, more so when that refusal might be due to fear of the consequences that might follow as a result of action on the part of the B.M.A. The solicitude for members of the B.M.A. shown in (b) above is quite touching but it need hardly be said that the Council does not accept this as in any way representing the real situation or the views of the Association either in Tasmania or elsewhere. But there are great difficulties in even seeming to interfere with the right of the Dominions to govern themselves. The Council is therefore of opinion that, whilst strongly protesting against this legislation as being class legislation of the worst kind, the Association can take no further steps which would be of help to the Tasmanian medical profession in this matter. The episode is a warning to the profession here and elsewhere of the kind of penal legislation as to which the medical profession needs to be continually on its guard.

FEES FOR CERTIFYING FACTORY SURGEONS.

206. The Council has offered to co-operate with the Association of Certifying Factory Surgeons in an endeavour to obtain an increase in the fees for these Surgeons.

PRISON MEDICAL OFFICERS.

207. After full consideration of the salaries and conditions of service of whole-time Prison Medical Officers, the Council informed the Home Secretary that it was considered that the commencing salaries and the annual increments of whole-time Prison Medical Officers were too low, and it was suggested that the increments should be raised from £20 to £50 for Senior, and from £15 to £25 for Junior Medical Officers. The Home Secretary was asked to take steps to secure that those Officers who had been in the Service prior to the institution of the improved scale of salaries should receive relatively higher salaries than those Officers who had joined the Service on the improved scale. He was also informed that the Association was of opinion that the maximum salary for whole-time Medical Officers should be increased to at least £800 per annum. The Home Secretary replied that in view of the present high rate of bonus to these Officers and the financial position of the country, he felt it impossible to ask the Treasury or Parliament for any further increase, and the Council, after due consideration of all the circumstances, has decided to take no further action at present.

208. Representations have also been made to the Home Secretary with regard to part-time Prison Medical Officers, and as a result thereof an increase of 30 per cent. in salary has been granted, as from 1st April, 1920, to those part-time Officers whose salaries had not been increased during the war. A fee of £2 2s. has also been sanctioned for each confinement attended by Medical Officers in prisons, and a fee of 10s. 6d. for each report required by a Court of Law, if the Medical Officer is not called as a witness and if he receives no fee as such from the Court.

CENTRAL COUNCIL FOR DISTRICT NURSING IN LONDON.

209. In response to a request from the Ministry of Health to nominate three representatives of the Association to serve on the Central Council for District Nursing in London (for the third triennial period of that Council), the Council has nominated the previous representatives of the Association, namely, Mr. E. B. Turner, Dr. T. W. H. Garstang, and Dr. M. G. Biggs.

DEVELOPMENT OF THE MEDICAL SERVICES OF WILLESDEN URBAN DISTRICT COUNCIL.

210. The rapid development of the Public Health Services of the Willesden U.D.C. has been considered by the Council, apart from the general question of the municipalisation of hospitals and clinics. The general outline of the Scheme is the establishment of a Municipal Hospital, with School and Maternity and Child Welfare Clinics staffed by whole-time salaried Medical Officers. The apparent intention of the Willesden U.D.C. to render the private practitioner superfluous to the great bulk of the ratepayers has caused serious alarm to the local practitioners. Every assistance is being given to the Division in the formulation of an alternative scheme, which while assisting the U.D.C. in all legitimate attempts to provide medical service to those who cannot provide it for themselves, shall preserve the right of the private practitioner to earn his living without unfair competition from the body spending the rates to which he is a contributor.

211. Arising out of the consideration of above matter by the Medico-Political Ministry of Health, Public Health and Hospitals Committees, the Council summoned a joint meeting of the four Committees. A Memorandum was prepared and placed before that meeting with the object of focussing the discussion upon the question of municipal hospitals and clinics and the relations thereto of medical officers employed by municipal authorities, and private practitioners. A further Conference of the four Committees is to be held for the purpose of completing the discussion.

212. The attention of members is drawn to the report of the proceedings which appeared in the *B.M.J.* Supplement of April 2nd, from which it will be seen that there was considerable agreement upon many general principles, with healthy differences as to details, in connection with the work of medical inspection and treatment of School Children. A further Conference is to be held to deal with the remaining subjects placed before the meeting, namely, Maternity and Child Welfare Work and Municipal Hospitals.

DANGEROUS DRUGS ACT, 1920: DRAFT REGULATIONS.

213. The Dangerous Drugs Act, 1920, was intended to control the sale and distribution of drugs—used by drug abusers—*i.e.*, opium, morphia, cocaine, heroin—and it gave the Home Secretary power to make Regulations. A set of Draft Regulations was issued by the Home Office on 7th January, 1921, and if no strong objection had been taken to them there is little doubt that at the end of the prescribed 10 days they would have become law, after which they could only have been withdrawn on the vote of one of the Houses of Parliament. This original draft required practitioners to keep in special books records of all purchases and supplies of “the drugs”—morphine, cocaine, ecgonine, heroin and medicinal opium, and these records were to be open at any time to inspection—presumably by the police. Apparently a separate set of books would be required at each branch surgery and call house. A prescription in writing was to be given whenever “the drugs” were ordered even apparently if they were used for personal administration. The name and amount of “the drugs” was to appear on any bottle or package containing “the drugs” and the draft apparently placed quite unnecessary difficulties in the way of “the drugs” being got by patients or used by doctors. The Draft Regulations showed an astonishing ignorance of the conditions of practice. The Home Office had not consulted the Association before issuing the Draft, but it afterwards explained that that document had been submitted to the Royal College of Physicians, London, the Royal College of Surgeons, England, and the General Medical Council, none of whom had taken objection to it. Immediately on receipt of the Draft the Home Secretary was informed that the Regulations were hopelessly impracticable and useless for the purpose of limiting the abuse of drugs. The Association took joint action with the Pharmaceutical Society of Great Britain (whose help, and especially that of Sir William Glyn-Jones, its Secretary, has been of the greatest value) and other bodies representing the manufacturers and wholesale and retail distributors of the drugs, and asked the Home Secretary to receive a joint deputation. This he refused, as also the suggestion that he should appoint a small expert Committee to advise him *de novo* on the Regulations. In company with the bodies above-mentioned a campaign in the Press and amongst Members of Parliament was at once instituted. The Parliamentary Medical Committee gave its assistance and so did many other members, amongst whom Mr. W. J. Uglow Woolcock, Mr. J. D. Kiley and Sir Henry Craik deserve special mention. The Divisions and Branches and the Panel Committees were urged to approach their Members, with the result that the meeting of Members of Parliament which took place on 9th March, 1921, has been described as the biggest meeting of its kind within the memory of the oldest Member. At that meeting it was evident that the pressure on the Home Secretary had had the desired effect, for he had on the same afternoon announced the setting up of a Committee to advise him on the Regulations. The Committee was composed as follows:—

Mr. Chester Jones (Chairman); Sir Malcolm Delevingne, K.C.B.; Capt. W. E. Elliott, M.C., M.P.; Major A. C. Farquharson, M.P.; Mr. Gerald A. France, M.P., and Mr. W. J. U. Woolcock, C.B.E., M.P.: to which Sir Beville Stanier, M.P., was afterwards added.

A *precis* of evidence was prepared by Dr. J. W. Bone and the Medical Secretary, who both gave evidence on 22nd March, 1921, and the Medical Secretary was recalled on April 4th. In their evidence they made it clear that while the Association did not wish to be merely obstructive and was willing to help any practicable efforts to check drug abuse, it considered most of the Draft Regulations and especially that part which required the doctor to keep a record of the ingoings and outgoings of “the drugs” to be quite useless and therefore irritating.

214. The Home Secretary had in a letter of 15th February announced many important modifications in the Draft as a result of the written representations of the Association, and at the meetings of the Departmental Committee still further concessions were announced. The numerous alterations which have been made in the Draft are the best justification for the action of the Association and the bodies co-operating with it. The Council will report further on receipt of the Regulations as revised by the Departmental Committee.

NEW RATES FOR TELEPHONE.

215. The Council has decided that, whilst regretting the increase in the rates for telephones, it is of opinion that the new rates will not weigh more heavily on medical men than on other classes of telephone subscribers, and that there are not sufficient grounds for asking for special concessions for the medical profession. The bulk of the calls through a doctor's

telephone are “in-calls” and therefore any flat rate devised to meet the large consumer would probably be dearer for the doctor than the new rate. That is always assuming that charges must be largely increased—a point on which the Government has been very emphatic. The Government inquiry into the whole telephone system which has just been set up will it is hoped provide some relief for medical subscribers.

NOTTINGHAMSHIRE COLLIERY APPOINTMENTS.

216. The Council is gratified to be able to report that after negotiations extending over several months, agreement has been arrived at between the Nottinghamshire practitioners and the colliery clubs in respect of an application by the practitioners for an increase of salary from 16s. 3d. to 26s. per annum per family. The agreement provides (i.) that payment be increased to 5d. per week per married man (*i.e.* 21s. 8d. per annum); (ii.) that medical attendance be provided for wives, and families under 16 years of age; (iii.) that unmarried members be allowed the same privilege, the 5d. per week providing for a widowed mother and family; (iv.) that certificates for clubs be supplied free of charge; and (v.) that boys aged 14 to 16 whose parents do not work at the colliery be entitled to medical attendance at half rate. The Nottingham Division is to be congratulated on the example it has given of the way in which the Association can confer great pecuniary benefits on its members—and also on non-members.

FEES FOR ADMIRALTY SURGEONS AND AGENTS.

217. The Council has been pursuing this subject with the Admiralty for 12 months, and at one time it looked as if the Admiralty had extracted reasonable terms from the Treasury, but some hitch occurred. For many months now the only satisfaction the Council has been able to get has been that the matter was “under consideration.” At the instance of the Association Captain W. E. Elliot, M.P. (Secretary, Medical Parliamentary Committee) asked a question on February 25th, 1921, to which the Parliamentary Secretary of the Admiralty replied that a revised scale of fees was under consideration and it was hoped that a decision would be reached and promulgated shortly. On April 13th, 1921, the revised scale not having been issued, Captain Elliot repeated the question and the Admiralty announced a revision of fees which is rather more than equal to 50 per cent. of the visiting fees and mileage.

THE MEDICAL PROFESSION AND WHITLEY COUNCILS.

218. The development of National Joint (Whitley) Councils is a matter of considerable importance to the profession and to the Association. If the remuneration and conditions of employment of doctors who are employed by the State or by Municipal Authorities, are to be settled by National Joint Councils, the doctors so concerned will probably to a large extent have to sacrifice their special position as technically trained and qualified persons and rank primarily as civil or municipal servants. So far, the results of these Councils as affecting the profession have not been satisfactory but, whatever the results, the doctors concerned are to a large extent cut off from their professional brethren and they may be obliged to sacrifice that support which the Association might be able to give them were they not concerned in any such Council. As the Council of the Association is desirous of testing the feelings of the various sections of the profession concerned, it has been decided to call together preliminary conferences, of the medical bodies concerned in the proposal to form National Joint Councils for the medical profession. In the first instance it is considered advisable that if medical practitioners are to be dealt with by these bodies arrangements should be made for two such Councils, one for the medical personnel of the Civil Service, and one for the medical personnel of the Local Government Service. The medical personnel of the following Government Departments (Ministry of Health, Ministry of Pensions, Home Office, Board of Education, Board of Control and Lunacy Board) are being invited to send not more than one representative each to a preliminary conference on the advisability of forming a National Joint Council for the medical personnel of the Civil Service. With a view to a preliminary conference on the formation of a National Joint Council for the medical personnel of the Local Government Service, the following societies are being invited to send not more than one representative each: Society of Medical Officers of Health, Association of County Medical Officers of Health, Association of School Medical Officers, Infirmary Superintendents Association, Poor Law Medical Officers Association, Association of Public Vaccinators, Assistant Asylum Medical Officers Association, Tuberculosis Society, Medico-Psychological Association and the Medical Women's Federation.

FEES FOR CERTIFICATION UNDER (A) LUNACY ACT, AND
(B) MENTAL DEFICIENCY ACT.

219. The attention of Divisions and Branches and Members of the Association generally has been drawn to the fact that the fees for certification under the Lunacy Act and the Mental Deficiency Act are fixed by Magistrates, and it has been suggested to the Divisions that local action should be taken to ensure that a fee of at least one guinea is paid for such certification. There are apparently a good many areas in which a less fee is paid.

MINIMUM SALARIES FOR PUBLIC APPOINTMENTS.

220. Pursuant to the following Minute of the A.R.M., 1920:—

Minute 106.—Resolved: That this Meeting is of opinion that a substantial addition is needed to all Public Health Salaries on the general lines of the scale indicated in Items 77-112 of the Agenda and that a Conjoint Committee of the B.M.A. and the Society of M.O.H. be formed to take charge of the case for improvement in the salaries of Medical Officers in the Public Health Services and to report to the Council of the B.M.A. and of the Society of M.O.H. as to any steps that may be necessary to this end,

a Conjoint Committee of the B.M.A. and Society of M.O.H. was formed and has held three meetings.

221. The position with regard to agreement on a scale of salaries for Public Appointments has been complicated by the affiliation of the Society of M.O.H. with the National Association of Local Government Officers. This latter Association, which comprises all grades of Local Government Officers, is a certified trade union. The representatives of the Society of M.O.H. informed the Council that they considered that as the N.A.L.G.O. had been authorised by the Government to prepare and submit to the National Joint Council for Local Authorities, Administrative, Technical and Clerical Services (otherwise known as the Whitley Council) scales of salaries for all Local Government Officers, representation of medical officers employed by local authorities on the N.A.L.G.O. was advisable, as, whether medical officers were represented or not, such scales would be prepared, including one for medical officers. They had, therefore, submitted the scale of salaries for Public Health Officers (with certain amendments), which was before the A.R.M. in 1920, to the arbitration of the Whitley Council through the N.A.L.G.O.

222. Prior to the meeting of the Conjoint Committee of 3rd December, 1920, the Council's representatives on the Conjoint Committee met and thoroughly discussed the whole position of medical men employed by Government Departments and Local Authorities, and the bearing of the Whitley Council idea upon them, and particularly the special case presented by the Society of M.O.H. At the meeting of the Conjoint Committee which followed, the following resolution of the B.M.A.'s representatives was placed before the representatives of the Society of M.O.H.:—

Resolved: That the representatives of the Society of Medical Officers of Health on the Joint Committee be informed at the meeting on the 3rd December:—

That the Association's representatives on the Joint Committee are prepared to recommend the Council:—

(a) to give any support within the power of the Association to the Society of Medical Officers of Health in putting forward their claim through the N.A.L.G.O., for the scale approved by the Council of the Society on the 24th September 1920;

(b) to give the full support of the Association to the Society in demanding from all Local Authorities the scale accepted by the Whitley Council, whatever it may be, for the time during which the Whitley Council award lasts;

(c) pending the negotiations with the Whitley Council (or in case the Whitley Council machinery should break down) to adopt and support by all means in its power a scale of minimum salaries not less than that stated in the June scale or more than that approved by the Council of the Society on the 24th September, 1920 (in each case omitting the bonuses);

(d) to use all the means in its power to obtain, in addition, bonuses for Medical Officers in all suitable cases approved by the Society and the Association;

This recommendation to be subject to an undertaking on behalf of the Society of Medical Officers of Health:—

(i.) To support the principle which is to be recommended to the Council of the Association, namely, that there should be a special Whitley Council (or Councils) established for the medical profession in the public services;

(ii.) To give all possible assistance in obtaining the formation of such Council or Councils;

(iii.) To abandon the project contained in paragraph 14 of the Report of its Special Salaries Committee of 29th October, 1920, namely, the formation of a Special Committee, composed on the one side of representatives of the State or Local Government, and on the other side by representatives of the Society of Medical Officers of Health, to deal with the special interests of Medical Officers of Health; and

(iv.) That in the event of a Whitley Council or Councils being set up for the medical profession, the Society will retire from the N.A.L.G.O. and place its case in the hands of the appropriate Medical Whitley Council.

223. The result was that the Society of M.O.H. expressed agreement with paragraphs (a) and (b) and (i.) and (ii.) of the resolution but felt that it would be inopportune to accept paragraph (c) whilst the question of remuneration was still under consideration by the National Joint Council for Local Authorities' Administrative, Technical and Clerical Services, and suggested that consideration of this, and paragraph (d) could with advantage be deferred pending the decision of the National Council. With regard to paragraphs (iii.) and (iv.), the Society felt that if a Special Whitley Council were set up for the medical profession employed in the Public Services it would be best for separate Committees of such a Council to be formed for each section of the profession represented. The Society is prepared to place its case in the hands of a National Whitley Council established for the medical profession, provided a satisfactory arrangement under paragraph (iii.) is come to.

224. The Council views the situation with great concern, at the Whitley Council idea is still in its infancy and if the Society of M.O.H. permanently throws in its lot with the N.A.L.G.O. serious injury might be done to the solidarity of the profession and to the influence of the Association. The Council felt that it would be justified in attempting to prevent this by promising the full support of the Association towards the scale of salaries of the Society of the M.O.H. on condition that this scale was accepted by the Whitley Council. The responsibility for the acceptance of the scale would then rest on a joint body composed of the employing interests on the one side and of the employed on the other side. Whatever doubts the Association might have as to the expediency of such a scale would matter little if the representatives of the Local Government Authorities on the Whitley Council had given their sanction to it. Until the Whitley Council has made a pronouncement on the scale of salaries submitted to it, the Council is of opinion that the Association cannot take any further steps, and the Society of M.O.H. agrees that such is the position.

MINISTRY OF PENSIONS MEDICAL OFFICERS.

225. The Council has been in active communication throughout the session with a body representing the whole-time medical officers of the Ministry of Pensions, both administrative and hospitals. The position of these officers is complicated by the fact that they are parties to a Departmental Whitley Council, the main influence of which seems to have been to delay quite unduly the examination of the special case of these officers. The Council has rendered all help possible and hopes shortly to report that a permanent working agreement has been arrived at by which the care and the interests of these officers will be entrusted solely to the Association.

PENSIONS MEDICAL REFEREES.

226. The attention of the Ministry of Pensions has been repeatedly drawn by letter and interview to the grievances of these ex-officers who believed that they were not getting their fair share of the Board work. The Council is glad to report that these representations were always received courteously and sympathetically and many individual hard-ships have been remedied.

National Health Insurance.

CONSTITUTION OF COMMITTEE.

227. The October, 1920, Conference of Representatives of Local Medical and Panel Committees expressed the opinion that each Annual Conference should appoint the Chairman of the next Annual Conference, and referred to the Insurance Acts Committee for consideration the suggestion that he should not be a member of that Committee. The Council is in entire agreement with the opinion that the Conference should elect its own Chairman to hold office from the end^{of} the Conference at which he is appointed to the end of the succeeding Annual Conference, as is the case with respect to the Chairmanship of the Representative Body. But the Council is strongly of opinion that whoever is appointed Chairman of the Conference should, during his year of office, be fully acquainted with the work of the Insurance Acts Committee, and that this experience can only be gained by membership of the Committee.

The Council therefore recommends:—

228. **Recommendation.**—That the following words be inserted in the second column (additional members *ex-officio*) of the Schedule to the By-laws referring to the Insurance Acts Committee:

"The Chairman for the time being of the Conference of Representatives of Local Medical and Panel Committees called by the Insurance Acts Committee of the British Medical Association."

CONFERENCE OF REPRESENTATIVES OF LOCAL MEDICAL AND PANEL COMMITTEES.

229. The Annual Conference of Representatives of Local Medical and Panel Committees was held on October 21st, 1920, under the Chairmanship of Dr. H. G. Dain (Birmingham), and was well attended and very representative. A full report of the proceedings was published in the *B.M.J.* Supplement for October 30th, 1920. The Conference decided to elect its own Chairman at each Annual Conference, to hold office for the succeeding twelve months. Dr. H. G. Dain was elected Chairman for 1920-21.

MEDICAL RECORDS.

230. As reported in the Annual Report of 1920 the Minister of Health and Scottish Board of Health appointed an Inter-departmental Committee "to consider and advise them as to the form of medical record to be prescribed under the conditions of service for medical practitioners contained in the new Medical Benefit Regulations, having due regard to the clinical purposes (including the remedial value to the patient of obtaining a suitable record of his case) as well as to the administrative and the statistical purposes which such records may be adapted to serve." Its report was issued in June, 1920. After consideration of the report, which fully described the nature of the new record, and which had been sent by the Ministry to every Panel Committee, the October 1920 Conference decided to express no opinion on it then, but to recommend insurance practitioners to give the new record card a fair trial before either condemning or approving it. The new record card came into operation on January 1st, 1921, and its introduction aroused a certain amount of criticism amongst insurance practitioners. Some of this was due to a want of appreciation that the form of record had been discussed by the Conference; some was due to a belief that the form was not satisfactory, and that some of the work entailed by it was unnecessary; but the criticism was in a large measure due to the efforts of a section of the lay press to prove, for their own purpose, that the card would violate the time-honoured custom of professional secrecy.

231. In view of the misconception which appeared to exist amongst a large number of practitioners as to what was required from them in connection with the cards, a circular was issued to all insurance practitioners (a) setting out their obligations in connection with the keeping of the cards, and (b) dealing with the question of the violation of professional secrecy. At the same time a Memorandum was issued to Local Medical and Panel Committees giving, in addition to (a) and (b) mentioned above, a short history of record cards from the inception of the Insurance Act. Panel Committees are being asked to forward by the end of June any observations they have to make as the result of experience of the new record cards, with a view to a report thereon being submitted to the Annual Conference in October. The whole question will thus be fully considered in the light of the experience gained. If

necessary, the Ministry will be asked to modify the existing form, or the methods of dealing with it, in such ways as the Conference may suggest.

MEDICAL AID INSTITUTES AS "APPROVED INSTITUTIONS."

232. The Middlesbrough Friendly Societies Medical Aid Institute desired to extend the area of its activities beyond the three miles radius prescribed in its "approval" by the Commissioners in 1913. The Ministry of Health held an inquiry into the matter on January 4th, 1921, which was fully reported in the *B.M.J.* Supplement of January 15th, 1921, and from which it will be seen that there were strong local reasons why the application should be resisted by the local medical profession, in addition to the objection felt by the profession in general to any extension of a system believed to be unsound. The Medical Secretary on behalf of the Association drew attention at the inquiry to the conference between representatives of the Friendly Societies and the Association, held in October, 1912, under the Chairmanship of Mr. Lloyd George, at which the Association agreed, on certain conditions, not to press its opposition to the "Harmsworth amendment" to the National Insurance Bill, under which certain Medical Aid Institutes would be recognised as part of the machinery of the National Insurance system. One of the conditions, as understood by the Association's representatives, was that those institutions would not seek to extend their operations outside the areas in which they operated at the time the Act was passed. The result of the inquiry was satisfactory, inasmuch as the Minister declined to allow the alteration of the rules asked for by the Institute.

TRANSFER OF PRACTICES.

233. The Annual Representative Meeting, 1920, instructed the Council to take active steps to further the just claims of insurance practitioners in the preservation of the capital value of their panel practices, and the Insurance Acts Committee has, as a result of the foregoing and somewhat similar instructions received from the October Conference, urged upon the Ministry of Health that a return be made to the position that obtained under the original Regulations, with certain modifications. Negotiations have been in progress for some time on this matter, and the Insurance Acts Committee hopes to be able to recommend certain proposals to the next Conference which it is believed may be acceptable to the Ministry, while securing the objects desired by the profession.

RANGE OF SERVICES—VACCINATION.

234. Pursuant to the instructions contained in Minute 188 of the A.R.M., 1920, the Solicitor's opinion was obtained as to whether the vaccination of insured persons came within the scope of the agreement with Insurance Committees under the old regulations. He was of opinion that if an insured person upon the list of an insurance practitioner asked the latter to vaccinate him and the practitioner considered it necessary or desirable that it should be done, the practitioner was, by virtue of his agreement, under an obligation to do it and could not charge or accept a fee for so doing. It is quite clear that vaccination comes within the practitioner's agreement under the 1920 Regulations, if such vaccination commends itself to the practitioner's judgment.

CENTRAL INSURANCE DEFENCE FUND.

235. The R.B. in 1918 passed the following resolution:—

Minute 88.—Resolved: That the balance in hand of the Central Insurance Defence Fund should either be transferred to the donors, or a scheme for its utilisation submitted to them for their approval,

and at the same time the Insurance Acts Committee was considering the question of the formation of a Defence Fund for practitioners working under the National Health Insurance Acts. The new fund—the National Insurance Defence Trust having been decided upon, the Council in October, 1918, decided after taking the advice of the Solicitor, that the Central Insurance Defence Fund be closed and that the subscribers to that Fund be informed by a circular (i.) that the Fund had been closed; (ii.) that a new Fund had been opened, with the reasons for taking that step, and (iii.) that the balance of their subscriptions (amount of balance to be stated) would be returned to them if they so desired, but that it was hoped that they would allow it to be transferred to the new fund, and that their consent to do so would be assumed unless they applied within three calendar months for its return.

236. As a large number of practitioners who subscribed to the Central Insurance Defence Fund were still on active service, the Council left it to the Insurance Acts Committee to decide when the appropriate time had arrived at which the attempt should be made to induce those subscribers to transfer their balances to the new fund. In December, 1920, upon it being decided that the time was ripe for action, the Association's Auditors, Messrs. Price, Waterhouse & Co., were instructed to commence the process of winding up the old fund, and in January, 1921, a circular was issued to all those subscribers who had balances, asking them if they desired their balance returned to them, but expressing the hope that they would allow such balance to be transferred to the new fund—the National Insurance Defence Trust. The work of winding up the old fund is entirely in the hands of Messrs. Price, Waterhouse, and is nearly completed. The Council hopes to be able to report the conclusion of the process in its Supplementary Report.

UNQUALIFIED PRACTITIONERS AND INSURED PERSONS.

237. Several insurance practitioners have applied for advice and assistance in connection with claims made on them that they should grant certificates to insured persons who were receiving attention from unqualified practitioners—principally bone-setters. Acting on the advice of the Solicitor of the Association they have been advised to cease attendance and the giving of certificates to such insured persons, and to request the Insurance Committee to remove the insured persons' names from their (the practitioners') lists, thus declining all responsibility for any further attendance or certificates. The practitioners were also advised that to continue to give certificates to such persons whilst under the treatment of an unqualified person might bring them under the censure of the General Medical Council, as it would probably be regarded as "covering."

238. The insurance practitioners and the Panel Committees concerned acted immediately upon the advice given, with the result that in every case the Insurance Acts Committee was informed that the difficulty had disappeared owing to the insured person ceasing to receive attention from the bone-setter. The Council felt that the principle involved was so important that it has promised that the full support of the Association shall be given to any practitioner against whom action is taken for refusing to give attendance or certificates to insured persons who have put themselves under the care of unqualified practitioners.

Public Health and Poor Law.

DANGER OF NEGLECT OF VACCINATION.

239. Pursuant to Minute 192 of the A.R.M., 1920, the Council has drawn the attention of the Ministry of Health and the Scottish Board of Health to the necessity of the more thorough vaccination of the community and the danger of the neglect of that precaution.

MILEAGE FEE FOR PUBLIC VACCINATORS.

240. The Council has considered the desirability of drawing up a model scale of mileage fees for Public Vaccinators, and has asked the Association of Public Vaccinators to co-operate.

ALLEGED SUPERSESSION OF POOR LAW DISTRICT MEDICAL OFFICERS.

241. In view of the threatened supersession of part-time District Medical Officers by whole-time Medical Officers attached to Poor Law Infirmarys, the Council informed the Ministry of Health that in its opinion the appointment of whole-time Officers to do the domiciliary work where it had previously been satisfactorily performed by District Medical Officers resident in the area was not desirable. A reply was received stating (i.) that no action was in contemplation by the Minister which would affect or interfere with the tenure of office of any medical officer employed by Guardians; and (ii.) that the Minister would not consider any such arrangement unless substantial grounds were adduced by Boards of Guardians in support of the proposal.

SUB-COMMITTEES.

242. For the past three or four years it has been the custom to appoint a M.O.H. Sub-Committee and a Poor Law Medical Officers' Sub-Committee of the Public Health Committee and to put on these

Sub-Committees nominees of the Society of M.O.H. and the P.L.M.O.'s Association respectively. The composition of this year's Committee was such that it was felt unnecessary to re-appoint these Sub-Committees, for it contains five whole-time Medical Officers of Health and one part time; while two of the members are P.L.M.O.'s. The Society of Medical Officers of Health, the Association of County Medical Officers, and the Poor Law Medical Officers' Association, on being informed of this fact, urged the reconsideration of this decision, but the Council, after carefully reviewing the position, decided to defer any further consideration thereof until next session.

ROYAL SANITARY INSTITUTE CONGRESS.

243. Drs. Herbert Jones and E. H. Snell attended the Congress of the Royal Sanitary Institute on 19th-24th July, 1920, as representatives of the B.M.A.

SUPERANNUATION OF MEDICAL OFFICERS OF HEALTH.

244. On the 8th June, 1920, the Minister of Health was asked to receive a deputation from the B.M.A. and the Society of Medical Officers of Health on the question of the Superannuation of Medical Officers of Health—a memorandum setting forth the views of the Association on the subject having been sent in previously at the request of the Ministry. The Minister intimated that the views of the two bodies on the recommendations of the Departmental Committee on the superannuation of persons employed by Local Authorities would receive his careful consideration, and that he had informed a deputation from the National Association of Local Government Officers that he would put forward proposals to the Government on the matter. On 27th October, 1920, the Minister announced in Parliament that a Bill would be introduced at an early date. On March 15th, 1921, in reply to a question in the House, Dr. Addison stated that in view of the heavy charges upon the rates which would be entailed by the introduction of a National Superannuation Scheme for Local Government Officers, the Government regretted that it could not proceed with this matter at the present time. The Council, after careful consideration of the position, decided regretfully to take no further action in the matter for the time being.

SECURITY OF TENURE OF HEALTH OFFICERS.

245. In June, 1920, Sir Philip Magnus, who has long taken a very active interest in the subject, reported that he had been informed officially that it was proposed to proceed with the issue of an Order giving security of tenure to Medical Officers of Health and Sanitary Inspectors. On November 2nd, 1920, a message was received from the Ministry that the Order was in proof and would be issued in a few days. As this Order was not published, the Council tried to get suitable clauses in the Ministry of Health (Miscellaneous Provisions) Bill. This Bill was, however, rejected by the House of Lords, and the Council then decided that it would be advisable to introduce a private Parliamentary Bill to give effect to this object. Accordingly the Public Health (Officers) Bill, as drafted by the Association and approved by the A.R.M., 1910, has been amended so as to provide for the security of tenure of M.O.H., Sanitary Inspectors, and Inspectors of Nuisances, and Sir Philip Magnus, with the support of the Medical Parliamentary Committee, introduced the Bill into Parliament, which passed Second Reading on 14th April and stands referred to a Committee. It is believed it will have the support of the Ministry of Health.

POSITION OF MEDICAL OFFICERS OF HEALTH WHO ARE DISPOSSESSED.

246. Several cases have arisen in which Medical Officers of Health have applied to the Association for advice as to compensation in connection with their loss of appointment, either by abolition of office or absorption of area. As it was considered that the absorption of areas might very probably become more general, the Council decided that, where desired, an effort should be made to obtain for such officers a sum of money for each year of service based on one-sixtieth of the average salary for the last five years' service, plus:—

For 20 years of service and upwards	...	10 60ths additional.
" 15 "	but under 20	7 60ths "
" 10 "	" "	5 60ths "
" 5 "	" "	3 60ths "
Under 5 "	" "	1 60th "

These terms are based on a recommendation in the Report of the Departmental Committee on the Superannuation of persons employed by Local Authorities in England and Wales.

FEES FOR REPORTS BY TUBERCULOSIS OFFICERS ACTING AS MEDICAL REFEREES FOR THE MINISTRY OF PENSIONS.

247. The question of the payment of Tuberculosis Officers acting as Medical Referees to the Ministry of Pensions for filling up Form M.R.1 has been considered by the Council, in view of complaints made by a group of Tuberculosis Officers that they had been informed in November, 1920, that they were no longer entitled to draw the fees which they had been drawing for this service for the past two years. The fee usually paid for this service was 5s. T.O.'s strictly speaking were supposed to do this work as part of their ordinary duties, but owing to the fact that some County Councils had allowed their T.O.'s to accept these fees, discriminations and consequent dissatisfaction had arisen. On representations being made to the Ministry of Pensions the Council was informed that the matter had been considered in conjunction with the Ministry of Health, and that it was proposed in future to substitute for the system of payment by fee a lump sum payment to Local Authorities in respect of certificates given by their T.O.'s acting as Medical Referees to the Ministry. In the meantime, however, the Ministry was prepared to pay a fee of 2s. 6d. to T.O.'s for each certificate issued by them as from 1st January, 1921, stating whether or not the man who had been recommended for treatment by them was able to work. The Council has advised applicants that the fee of 2s. 6d. offered by the Ministry of Pensions as an interim arrangement should be accepted, provided that the certificate is confined to a simple statement as to ability or inability to work; and has asked the Ministry to take all possible steps to insure that the lump sum payment which it proposes to make to the Authorities in respect of the completion of Form M.R.1 shall be paid to the T.O.'s in addition to their official salaries.

PUBLIC HEALTH AND POOR LAW APPOINTMENTS.

248. Successful action has been taken by the Association in connection with a number of Public Health and Poor Law Appointments in support of the policy of the Association in these matters. The Public Health cases comprised *inter alia* questions as to: (i.) Position of M.O.H. on abolition of office or absorption of area; (ii.) Salary of combined appointment of M.O.H. and School M.O.; (iii.) Requests for assistance to obtain increases of salary; (iv.) Compensation of M.O.H. called upon to resign on account of age; and (v.) Position of M.O.H. called upon by his Authority to examine applicants for posts under that Authority and to report on cases of alleged malingering amongst the Authority's employees.

249. The Poor Law cases dealt *inter alia* with:— (i.) Supersession of part-time P.L.M.O.'s and D.M.O.'s by whole-time officers; (ii.) Refusals by Boards of Guardians to grant increases of salary and to grant Civil Service bonus; (iii.) Question of increase of salaries of Parochial Medical Officers; (iv.) Appointment of D.M.O. who resided outside area; (v.) Appointment of non-service practitioner as P.L.M.O. whilst an ex-service practitioner had applied for the post; and (vi.) Salary of P.L.M.O. as affected by increases of work.

Hospitals.

CONFERENCE OF REPRESENTATIVES OF HONORARY STAFFS OF VOLUNTARY HOSPITALS.

250. Owing to the action of the Minister of Health in appointing a Committee "to enquire into and report upon the financial position of the Voluntary Hospitals throughout the country and to make recommendations" the Council called a Conference of Representatives of the honorary medical staffs of the Voluntary Hospitals containing 50 beds or more in England and Wales, for the purpose of discussing the situation thus created. The Conference took place in the Robert Barnes Hall, Royal Society of Medicine, by kind permission of the Society, on the 21st December, 1920, when 138 representatives attended. A report of the Conference appeared in the Supplement to the *Journal* of January 1st, 1921. It will be noted that the Conference requested the Council to instruct its Hospitals Committee to call the Conference together again when deemed desirable, and the Council will do so.

251. The resolutions of the Conference were thereafter considered and approved by the Council and are now submitted for the endorsement of the R.B. (Recommendations below)

Adoption of Voluntary Method of Administration of Voluntary Hospital

Recommendation.—That the R.B. desires to record its belief that the Voluntary method of administration of the Voluntary Hospitals of the country is to the advantage of the public, Medical Science and the Medical Profession, and that it should be maintained.

Necessitous Persons to be Treated Free.

Recommendation.—That necessitous persons shall continue to be treated free.

Subsidising of Voluntary Hospitals from Rates Undesirable.

Recommendation.—That it is undesirable that the Voluntary Hospitals should be subsidised by the local rating authorities, except in so far as payment is made for the examination and the care of patients for whom these authorities are responsible.

Subsidising by the Government of Hospitals in Financial Difficulties.

Recommendation.—That in times of financial difficulty it is desirable that the central Government should subsidise Voluntary Hospitals, and that such subsidy in the case of any individual hospital should take the form of a contribution proportional to the income received by the hospital from voluntary and other contributions. The subsidies here proposed should be made through some central hospital fund.

Support for Voluntary Hospitals by Employers and Insurance Companies.

Recommendation.—That greatly extended support for Voluntary Hospitals should be sought from Employers and Insurance Companies, seeing that they benefit largely both directly and indirectly by the services of the Voluntary Hospitals.

Contributions by Patients towards Maintenance.

Recommendation.—That every patient of a Voluntary Hospital who is not a necessitous person should make a contribution, during treatment, towards the cost of maintenance, unless the contributory method of subscription is adopted as essential in industrial areas. In view, however, of the increased cost of maintenance, etc., the R.B. considers that the contributory rates paid by workmen should be materially increased.

Payment of Practitioners for Services rendered to Paying Patients in Hospitals.

Recommendation.—That where Voluntary Hospitals provide accommodation for patients who are able to pay for it, no fixed rate of payment for professional services rendered to such patients should be established; the fees so payable to remain, as at present, a matter of arrangement between patient, family physician and consultant.

Formation of Medical Staff Fund.

Recommendation.—That in the event of decisions being taken which would lead to patients paying in part or in whole, the hospital maintenance fees, either individually or by some contributory method, or with the addition of rate aid or State aid, or by a combination of two or more of these methods, a percentage of all such payments should be passed into a fund which can be allocated in any manner which such honorary medical staff may determine.

EVIDENCE BEFORE GOVERNMENT COMMITTEE OF ENQUIRY INTO FINANCIAL POSITION OF VOLUNTARY HOSPITALS.

252. Evidence was given on behalf of the Association by Mr. Bishop Harman (Chairman of the Hospitals Committee), Dr. H. G. Dain, Dr. J. R. Drever (Scottish Medical Secretary), Mr. W. McAdam Eccles and Mr. A. E. Morrison before the Government Committee of Enquiry into the financial position of Voluntary Hospitals, and

followed the lines laid down by the resolutions of the Conference of members of Medical Staffs of Voluntary Hospitals Staffs.

PAYING PATIENTS IN POOR LAW HOSPITALS.

253. The attention of the Council has been drawn to schemes adopted in different parts of the country by Boards of Guardians so as to provide separate accommodation in their Poor Law Hospitals or Infirmarys for those persons who cannot secure early admission into the Voluntary Hospitals and who, whilst not being able to afford the expense involved by entering private nursing homes, are able to pay for less costly medical care treatment and nursing. There are some 13 or more schemes either contemplated or in operation, and as a rule no opportunity has been given to the profession to examine the scheme before its adoption by the Board of Guardians.

254. The Council has made representations to the Minister of Health in several instances and has thereby secured delay and an opportunity for local representation by the Divisions. Divisions have been advised whenever possible to insist upon two main principles, namely: (i.) that paying patients should be admitted into the Poor Law Hospitals only on the recommendation of their own private practitioners (if any); (ii.) that paying patients should be permitted to have in attendance upon them their own doctor whilst inmates of the Poor Law Hospital or Infirmary. The matter is one which, in the opinion of the Council, should not be dealt with piecemeal, as undesirable precedents are very likely to be set up in the absence of the recognition by the Ministry of Health of some general principles. The Minister has accordingly been asked to receive a deputation on the subject and has consented to do so.

The Council recommends:—

Recommendation—That the Report on the Future of Poor Law Infirmarys, with recommendations as to the utilisation of Poor Law Infirmarys for civil needs (see Appendix VIII.) be adopted.

BRADFORD SCHEME.

255. An account of what has happened at Bradford will be useful (a) to show the importance of the emphasis laid by the Association in its deputation to Dr. Addison on the necessity for consultation of the profession both locally and centrally before new schemes which affect the medical profession are floated; (b) as a record of a development which may have far-reaching effects and become an outstanding event in medico-political history; and (c) as an example of the ability and energy with which the profession can handle a difficult and dangerous local situation when thoroughly aroused and organised.

256. Bradford has for many years been famous as the home of municipal socialistic experiments. It has a large staff of whole-time medical officers whose activities are widespread and ever increasing. Therefore, when the Bradford Division heard of the proposal of the Bradford Health Committee to turn the recently acquired Poor Law Hospital into a Municipal General Hospital, without any reference to the local medical profession and apparently without any concern as to how the new hospital would affect the Voluntary Hospitals of the city, it was not surprised but felt that the time had come for decisive action. The whole profession was called together to consider the situation, and protests against the proposed developments were sent to the Health Committee and also to the Minister of Health. The Minister was reminded of his statement made to the Association's deputation that he was in favour of local consultation with the profession in such circumstances, and was informed that the Bradford profession was taking steps to form an Advisory Medical Committee which should be thoroughly representative of the whole local profession. The Minister replied by forwarding a letter he had sent to the Bradford City Council asking that body by what means it proposed to keep itself informed of the views of the profession as regards medical issues raised by its scheme.

257. The Bradford Division then, by means of meetings, circulars, etc., induced the local doctors to take a very active interest in the formation of the Advisory Medical Committee. The Committee when elected was composed as follows:—3 consultants, 9 general practitioners, 2 whole-time medical officers, and it is financed by a payment of 5s. a year from each of its constituents. As soon as it was appointed it set to work to draw up a report which should represent the views of the local profession for submission to the City Council. The Committee issued majority and minority reports, and the former, with some amendments,

was adopted at a largely attended meeting of the profession on March 17th and sent to the Health Committee, to the Ministry of Health, and to the Press, both medical and lay. (For report see Supplement, April 2nd, p. 91). As that report shows, the Bradford profession has not only criticised the proposals of the Health Committee as regards the Municipal Hospital, but has recognised the need for more hospital accommodation in the city and has put forward a constructive policy intended to assist the Health Committee in supplementing the resources of the Voluntary Hospitals by a scheme which would secure the support of the local profession.

FEES FOR X-RAY DIAGNOSIS AND TREATMENT OF TUBERCULOUS CASES REFERRED TO HOSPITALS BY LOCAL AUTHORITIES.

258. The Council has been asked to suggest the fees which should be paid to the members of the staff of a Voluntary Hospital for undertaking work in connection with X-ray diagnosis and treatment of cases which are referred to the hospital from the local Tuberculosis Dispensary.

The Council recommends:—

Recommendation.—That the fee to the practitioner conducting X-ray diagnosis and treatment of tuberculous cases referred to Hospitals by Local Authorities should be 21s. per case or £3 3s. 0d. per session not exceeding 2½ hours, in which not more than six cases should be seen.

FEES OF OPHTHALMOLOGIST TO POOR LAW INFIRMARY.

259. The Council's advice has been sought as to the fees which should be paid to ophthalmic specialists to Poor Law Infirmarys

The Council recommends:—

Recommendation.—That the remuneration of an ophthalmic specialist for attendance on Poor Law patients in Infirmarys should not be less than £2 2s. 0d. and mileage if outside London, and £3 3s. 0d. in London, as attendance fee, together with £5 5s. 0d. for each operation performed.

Naval and Military.

REPRESENTATIVE OF THE ARMY MEDICAL SERVICE ON THE COUNCIL.

260. The A.R.M. 1920 appointed Lieut.-Gen. Sir William Babbie, V.C., K.C.B., K.C.M.G., as the representative of the A.M.S. on the Council for the period 1920-23. A vacancy has, however, been caused by Sir William Babbie's death, and pending the appointment of his successor the Council has invited Major-General Sir William Macpherson to attend the meetings of Council and Naval and Military Committee.

Recommendation.—That Major-General Sir William Macpherson, K.C.M.G., C.B., A.M.S. (retired) be elected to represent the Army Medical Service on the Council for the period 1921-23.

SENIOR SURGEON COMMANDERS, R.N.

261. The Council in its last report stated that it had approached the Admiralty on the question of retired pay of those Senior Surgeon Commanders, R.N., who were adversely affected by the new Regulations governing retirement and retired pay which were introduced in January, 1920. The replies received to the Association's representations were of a most unsatisfactory character, and amounted to a complete refusal on the part of the Admiralty to make any concession. The Council felt that, in the interests of its Naval members, further action should be taken, and accordingly it has recently addressed a letter to the First Lord of the Admiralty personally, calling his attention to the injustice which has been done to those officers who have been retired compulsorily before reaching the age of 55, inasmuch as when they entered the service, they did so on the understanding that they would be eligible to serve to the age of 55. It was further pointed out that by their compulsory retirement before that age these officers have lost, or will lose, periods of from one to five years' service on full pay at a time when they would have been drawing the highest possible pay of their rank; and that whilst it was true that the retired pay of these officers has been increased by about 10 per cent., the new maximum of £600 is liable to a reduction of 20 per cent. in certain contingencies which, if it is enforced, will mean, that some officers will actually receive less than they would have got under the old scale. The Council informed the First Lord that the Association takes very serious exception to the treatment

which has been meted out to these officers, and I have asked that the whole question should receive his Lordship's serious attention as it is felt that the good faith of the Admiralty is involved. The Council awaits a detailed reply to its representations, and hopes to deal further with this matter in its Supplementary Report.

QUESTION OF INCREASE OF RETIRED PAY OF SENIOR SURGEON COMMANDERS WHO SERVED MORE THAN 20 YEARS.

262. The Council has also directed the attention of the First Lord of the Admiralty to the case of those Senior Surgeon Commanders who have served considerably more than 21 years and are now on the retired list with a rate of retired pay which can at the present time be earned by a Senior Surgeon Commander of 48 years of age with 21 years' service. The Council has pointed out that though it was undoubtedly the intention of the Government to give a substantial increase to all those who served in the war, and though practically all classes of officers, except Medical Officers, have received substantial increases, the retired pay of these Senior Surgeon Commanders has been increased by barely 10 per cent. The Council has urged that a concession should be made to these officers.

PAY AND RETIRED PAY OF THE R.A.M.C.

263. The Council has considered the question of the pay and retired pay of the R.A.M.C. The new scale of pay published in September, 1919, was not entirely satisfactory inasmuch as a Major of 20 years' service received less money under the new rates than he did under the old. The Council urged the reconsideration of this matter by the War Office, and it has now been rectified. In addition there was issued on October 9th, 1920, an amended scale of pay. The Council is of opinion that the new scale is a fair one, and that it compares favourably with those of other Services. There are, however, one or two points which still need consideration, such as the absence of any provision for an increase in the pay of Majors between 15 years' service and the date of their promotion to Lieut.-Colonel. The position of the D.G., A.M.S. as compared with the other Lieut.-Generals also needs attention.

INDIAN MEDICAL SERVICE.

264. The A.R.M. at Cambridge accepted the revised conditions of service for the Indian Medical Service, in satisfaction of the Association's demands, and the Council has accordingly through the columns of the *British Medical Journal*, etc., used its best endeavours to help recruiting for the I.M.S. The Council recognised that a reasonable time must be allowed to elapse before the new rates, etc., could be brought into operation, but owing to the very long delay which ensued in introducing the new rates for I.M.S. officers on the Civil side, the Council drew the attention of the India Office to the dissatisfaction which was being caused. It has since been learnt that the new rates were published in India on March 3rd and made operative as from January 1st, 1920. It was brought to the notice of the Council that the Administrative Officers of the Indian Medical Service feared they were to be excluded from the increase of pay granted to the other officers of the Service. The point was at once raised with the Secretary of State and an assurance has been received that the scales of pay for the Administrative Officers will be revised with effect from January 1st, 1920, although no promise is given that the scales of these highly placed officers will be raised to 50% above the pre-war figure. The Council has informed the India Office that it hopes that these officers will be dealt with generously, as their expenses have risen very considerably owing to the increased cost of living, and that it would be most unfortunate if these responsible officers were left with a feeling that in the general revision they had come out badly. The Council reports with satisfaction that since the new rates of pay for the I.M.S. were announced a number of officers have joined the Association. There are still, however, many members of the Service who are not members of the Association and the claims of the Association are being further pressed on these officers.

THE ASSOCIATION AND ITS SERVICE MEMBERS

265. The Council has dealt with many difficulties of a personal nature which have been brought to its notice by individual members, and in many cases has been able to take successful action with the authorities on behalf of the member concerned. The Council is fully cognisant of its responsibilities to its Service members, recognising that they are, by their conditions of service, debarred from standing up for themselves. It realises moreover that they are further handicapped by being scattered all over the world. Each Service has its own representative on the Council, and the

Naval and Military Committee deals solely with Service matters. The Council desires very specially to combat the erroneous impression which appears to prevail in some quarters that it gives preference in its interests or in its efforts to any one Service. It has taken up the cudgels for each and every Service in turn, and it will continue to do so whenever and wherever a good case can be found. As Service members are rarely able to have their interests looked after by a Branch or Division, they should not hesitate to avail themselves of the assistance and advice which can always be obtained by a personal call at the Head Office or by a letter addressed to the Medical Secretary. Such visits and communications are always regarded as strictly confidential.

Medico-Sociological.

266. The Council has appointed, experimentally, a Medico-Sociological Committee to consider social and economic questions affecting the public welfare as to which the medical profession has special knowledge, and to take such steps as may be found necessary in order to create or develop public opinion thereon. The Committee is at present discussing the question of the value of maternity and child welfare work in relation to the reduction of infant mortality, and for this purpose has co-opted various lay and medical members who have taken a prominent part in maternity and child welfare work, and has asked for the opinions of prominent workers in this field, both lay and medical.

Scotland.

DIRECT REPRESENTATIVES ON THE SCOTTISH COMMITTEE.

267. The first election of direct representatives under the new constitution was held in October last. A contest occurred in two out of the five groups, eight nominations being received for three vacancies in one group (Edinburgh Branch), and three for two vacancies in the other (Glasgow City). The election was conducted by postal vote, 60 per cent. of the electors voting.

FEEs TO PRACTITIONERS CALLED IN ON THE ADVICE OF MIDWIVES.

268. The Scottish Committee has been in negotiation with the Board of Health on the subject of the revision of the scale of fees, and proposed an inclusive fee of £2 2s. for all attendances at confinement, including immediate post-partum emergency, and including responsibility for any necessary attendances during ten days of the puerperium. This was not found practicable, as the Board held that under Section 22 (1) of the Act it was precluded from paying an inclusive fee to cover more than one subsequent visit, and they asked the Committee to submit new proposals on the lines of the revised English scale, allowing for the difference in after attendances. The Committee therefore substituted the following:—

1. Fee for all attendances during parturition and including one subsequent visit, £2 2s. 0d.
2. Fee for attendance of a second doctor to give anaesthetic, £1 1s. 0d.
3. Fee for suturing the perineum, for the removal of adherent or retained placenta, for the treatment of post-partum hæmorrhage or for any operative emergency arising directly from parturition, including one subsequent necessary visit, £1 1s. 0d.
4. Fee for attendance at or in connection with abortion or miscarriage, including one subsequent visit, £2 2s. 0d.
5. Fee for visits not included under (1) to (4):—
Day 5s.; Night 10s.
6. The usual mileage fees of the district to be charged.

and asked the Board to secure an amendment of the Act so as to permit of payment for attendances during ten days after parturition. Pending this alteration practitioners will be asked to give an honourable undertaking to give all necessary visits during the first ten days without additional charge. The Board has agreed to (2), (3), (5) and (6), and proposed under (1) a fee of £1 17s. 6d. (as compared with £2 2s. on the English scale and under (4) a fee of £1 1s. 0d. (the same as the English scale), which proposals are under consideration by the Committee.

SCHOOL CLINICS.

269. The Committee has asked from Secretaries of Divisions information as to schemes for attendance on school children, with a view to trying to secure the terms resolved upon at the last Representative Meeting. Action has been taken in several instances on the information received, notably in Renfrewshire, where the Education Authority offered a fee of 15s. per hour for attendance at clinics. On representations made by the Scottish Medical Secretary, acting in conjunction with the Division Secretary, the offer was amended to £1 1s. 0d. per hour.

CONFERENCE OF HOSPITALS STAFFS.

270. Two Conferences of Representatives of the Honorary Medical Staffs of Voluntary Hospitals have been held and have been well attended. At the first of these a resolution was unanimously adopted "That when a Hospital receives payment from any public body for the treatment of individual cases, a reasonable proportion of the amount received be put at the disposal of the medical staff." The Scottish Medical Secretary was instructed to send to the Governing Bodies of all hospitals in Scotland a Memorandum conveying the resolution and the reasons in support of it. At the second conference the present financial position of hospitals was considered and resolutions mainly but not entirely similar to those passed at the London Conference (*vide par.* 251), were passed affirming the voluntary principle. The Committee was asked to call further conferences when necessary.

REPORT OF THE SCOTTISH CONSULTATIVE COUNCIL.

271. The Committee has considered the Interim Report and has issued a Questionnaire to divisions. The replies have not been received in time for a report to be made in this document.

HIGHLANDS AND ISLANDS' MEDICAL SERVICE.

272. The Board of Health has replied to the representations of the Committee with regard to improvements in the terms of service, and has agreed to the proposals in respect of guaranteed minimum income in single practice areas, revision of scale of fees to be charged to patients, provision of locums, and provision of houses. It has not yet given its final reply on the question of increased mileage grant.

Wales.

STATUS OF WELSH COMMITTEE: REPRESENTATION OF WALES ON THE COUNCIL.

273. The alteration (agreed to last year by the Representative Body) to the By-laws, making the Welsh Committee more directly representative of the Welsh Divisions, has been greatly appreciated, although it has not been possible, so far this Session, to have more than one meeting of the Welsh Committee. The Committee feels that in comparison with Scotland and Ireland, Wales is under-represented on the Council, although its interests are just as special as either of those countries, and, in any alteration of the composition of the Council, will endeavour to see that the claim of Wales for two representatives thereon is not overlooked.

APPOINTMENT OF GENERAL PRACTITIONER TO THE WELSH BOARD OF HEALTH.

274. Representations were made to the Minister, the Welsh Board of Health and the Welsh Members of Parliament, as to the necessity for strengthening the Welsh Board of Health by the addition of a representative general practitioner. Many of the Welsh Members of Parliament received the representations quite sympathetically, but as no further appointments to the Board are contemplated, and in view of the present economic situation, it is not proposed to take any further action, notwithstanding the opinion of the Welsh Committee that the Board would be much stronger if it had upon it a member fully experienced in the special difficulties of the Welsh general practitioner.

CONTRACT PRACTICE IN SOUTH WALES.

275. The South Wales Branch has instituted a vigorous campaign against the contract practice "Schemes" in South Wales. A Contract Practice Sub-Committee composed of some of the most representative contract practice doctors in South Wales has met

frequently and has had before it reports from all the "disturbed areas." Dr. Ewen Maclean is chairman of the Sub-Committee. The Council at the request of the Welsh Committee has promised that the South Wales Branch shall have all the moral and pecuniary support in the power of the Association in fighting a battle which is considered to be not only the battle of Welsh colliery practitioners against debasing conditions of work, but a fight for the independence of the whole profession.

Ireland.

OFFICERS OF IRISH COMMITTEE.

276. Dr. Denis Walshe, Craigue, Co. Kilkenny, and Dr. John Mills, Ballinasloe, Co. Galway, were elected Chairman and Vice-Chairman respectively. The last meeting of the Irish Committee was held on October 20th, 1920. Owing to the very disturbed condition of the country and the great difficulties in travelling in several parts of Ireland, the Irish Committee has not yet held its usual Spring Meeting. As in previous years the greater part of Irish medico-political work has been done through a composite body called the Irish Medical Committee. The secretarial duties of this body are discharged in an honorary capacity jointly by the Irish Medical Secretary and the Secretary of the Irish Medical Association, thus reducing the expenses of administration to the cost of the stationery and postages.

IRISH PUBLIC HEALTH COUNCIL.

277. The outstanding event of the past year in Irish medical affairs was the publication of the Report of the Irish Public Health Council, a statutory body appointed under the Ministry of Health Act, 1919, to formulate proposals with a view to the submission to Parliament of an Irish Public Health Bill, which would, *inter alia*, place the public health services in Ireland on a wider and more comprehensive basis, and, where necessary, make mandatory on the local health authorities the various adoptive and permissive health enactments. The main recommendations in the Report of the Irish Public Health Council have been favourably received by the medical profession and have received very little adverse criticism from those interested. During the course of the deliberations of the Irish Public Health Council, deputations representing the Irish medical profession made many important representations on the subject of the reorganisation of the medical and health services in Ireland. The interests of the profession were well looked after both inside and outside the Council, and though this meant a great tax on the private time of those practitioners who acted as the representatives of the profession on the Council, as well as throwing an unusual amount of work upon the officials of the medical bodies, nothing was left undone to forward the best interests of the profession on every occasion. The Public Health Council in its Report recommended the co-ordination of central control of the medical and public health services in Ireland by the establishment of a Ministry of Health for Ireland and the formation within such a Ministry of a Health Council, composed of representatives of public and professional interests, to which should be entrusted the general direction of policy in regard to the administration of the medical and health services in Ireland. The proposal of such a Health Council is of far-reaching importance as it means the introduction of a new principle in administration, namely, the control by an elective body representative of the different interests concerned. The powers proposed for the Health Council are comprehensive and include the general policy and principles of administration of the public health and medical services. The proposed constitution of the Health Council is sixteen members, four of whom are to be representatives of the medical profession. The Chairman will be the Commissioner in charge of the Medical Department of the Ministry, and the Report recommends that he should have a casting vote in case of equality of voting. A meeting of Delegates, representative of the Irish medical profession, was held in the Royal College of Surgeons, Dublin, on October 20th, 1920. The chief business considered by the Delegates was the Report of the Irish Public Health Council, of which they approved generally, including the outlines of the proposed Irish Medical Service which, with the modifications suggested in the Report to meet local conditions, they considered should meet all the requirements of an

efficient health scheme for the Irish people. The Delegates were agreed that medical benefits, as administered in England, should be applied to the industrial areas in Ireland.

POOR LAW MEDICAL OFFICERS' SALARIES.

278. During the past two years the Irish Medical Secretary has attended meetings of Boards of Guardians in more than half the Poor Law Unions in Ireland for the purpose of stating the claims of the medical officials. In nearly all the Unions he visited scales of salaries have been adopted providing for increases varying from 80 to 120 per cent. The spirit in which the Boards of Guardians have met the claims of their doctors has, with few exceptions, been a very pleasant feature of the improved relations between these bodies and their medical officials. It is, however, very regrettable that recent legislation, in connection with the disturbed conditions in Ireland, should provide for the seizure of the hard-earned salaries of Poor Law and other medical officials and have them diverted to meet the awards for malicious injuries. In all Irish counties where the awards for malicious injuries are in excess of the local administrative funds, the result is that the Poor Law and other medical officials receive none of their salaries, notwithstanding that they have discharged their duties as heretofore.

AMALGAMATION OF MEDICAL ORGANISATIONS IN IRELAND.

279. The Irish Committee, at its meeting on October 20th, 1920, considered the position of the proposal for the amalgamation of Medical Organisations in Ireland, and whilst it was satisfied considerable progress had been made with regard to the question of amalgamation, it was however of opinion that much further progress could not be made until Irish Government had assumed a more definite and settled basis.

Oversea Branches.

WELCOME TO OVERSEA MEMBERS VISITING THE UNITED KINGDOM.

280. Oversea members intending to be present at the Annual Meeting at Newcastle in July are asked to notify the Honorary Secretary of the Newcastle Committee, Mr. R. J. Willan, M.V.O., F.R.C.S., 6, Kensington Terrace, Newcastle-on-Tyne, of the fact as early as possible. The Council wishes specially to remind members from overseas visiting the United Kingdom that the services of the Head Office staff are at their disposal for any advice or help in the power of the Council to give.

CONFERENCES OF OVERSEA REPRESENTATIVES AT ANNUAL REPRESENTATIVE MEETINGS.

281. In accordance with a wish expressed by Oversea Representatives, the Council has made arrangements for a Conference at each Annual Representative Meeting, of Oversea Representatives, Members of Council representing Oversea Branches, and visitors from overseas, being held prior to the discussion of matters specially affecting the Association overseas.

NEW OVERSEA BRANCHES.

282. Within the last two years Branches of the Association have been formed in East Africa, Nyasaland, Uganda and Zanzibar, and the Council hopes soon to form Mesopotamia, Sierra Leone and Tanganyika Branches. The question of formation of new Divisions or Branches in China is also being considered.

RELATIONSHIP BETWEEN THE OVERSEA DIVISIONS AND BRANCHES AND THE PARENT ASSOCIATION.

283. The Council published in the *B.M.J.* Supplement of March 5th 1921, (page 55), its report as to the question of steps whereby the Association may become in part a federation of medical bodies. It will be remembered that that question was first raised by some of the Australian Branches expressing a wish to be placed in possession of full power of managing their own affairs. The Council reports further on the general subject in paragraphs 63-64 of this report.

284. So far as specially affecting the Oversea Divisions and Branches, the Council desires to point out that the proposals provide machinery whereby the Association could, if and when this were desired, admit into close and formal co-operation with itself, bodies representing Oversea Branches or groups of Branches. But it must be carefully noted that a necessary preliminary of any such new arrangements would be that the Branch or group of Branches would cease to be a Branch or Branches of the Association. The Council naturally greatly prefers the retention of the existing relationship. The Council would not of its own accord propose that any Branch or Federal Committee should take steps, even preliminary to federation with the Association, whereby the Branch or Committee would cease to be a Branch or Committee of the Association. None the less, the Council recognises that in very special circumstances a Branch or group might come to the conclusion that this was the only means of securing that full and free self-government which some of the Oversea Branches have intimated to the Council that the interests of their work might require. If the new Articles and By-laws (*B.M.J.* Supplement, March 5th, 1921, pages 56-63) are adopted by the Divisions and Representative Body, and any Oversea Branch should in fact decide to take advantage of the new facilities and therefore cease to be a Branch of the Association in the ordinary sense, the Association would of course extend to it a hearty welcome as an affiliating body, and loyally do its utmost to give it the fullest and most helpful co-operation.

285. As mentioned in the March 5th Supplement, (page 56, paragraph 12), the Council has called, to meet on July 5th at the Head Office of the Association, for consideration of the whole matter, a Conference of representatives of the Oversea bodies and of Ireland, including the Representatives and Members of Council for those areas, with representatives of the Council. The Australian Federal Committee is being represented at the Conference by Dr. R. H. Todd, the Honorary Secretary of the Committee, and the New Zealand Branch by Dr. William Irving. The Conference will report to the Annual Representative Meeting at Newcastle.

AUSTRALASIAN MEDICAL CONGRESS.

286. Reports of the proceedings of the 11th Australasian Medical Congress, held in Brisbane in August, 1920, were published in the *B.M.J.* Supplement of November 13th and December 11th, 1920 (pages 163 and 194). The Council is gratified to learn that the Congresses will in future be held under the auspices of the Australian Federal Committee of the Association.

SOUTH AFRICAN MEDICAL CONGRESS, 1920: VISIT OF DR. J. A. MACDONALD (late Chairman of Council) TO SOUTH AFRICA.

287. The Council was pleased to receive from the South African Branches an invitation that a representative of the Home Association should visit that Country. At the request of the Council, Dr. J. A. Macdonald, late Chairman of Council, undertook to represent the parent body. He left England in September, 1920, and attended the South African Medical Congress in October, afterwards visiting the South African Branches. The cordial welcome and hospitality accorded to him have been a source of extreme gratification to the Council, and the visit has already had the result of increasing the interest taken by the Branches in South Africa in the work of the Association, and by the parent body in the work and welfare of the Association in South Africa. A full report of the visit was published in the Supplement of March 12th (page 70).

NEW SOUTH WALES BRANCH.

288. From the Annual Report for 1920 of the New South Wales Branch, the Council notes with much interest, not unmixed with envy, that the Branch held in the year no less than 23 meetings, viz., 9 ordinary, 6 extraordinary and 8 clinical, and that the Branch Council met 9 times in the year. Further, that the Standing Committees of the Branch Council (Executive and Finance, Ethics, Medical Politics, Organisation and Science) held between them a total of 49 meetings. The Council has long been of opinion that some of the Oversea Branches can give lessons to the Divisions and Branches at home as to effective

organisation and the above is a notable case in point. The splendid record of the Branch for 1920, for all these meetings were well attended, emphasises once again that most important factor in organisation, viz., the holding of regular meetings.

VICTORIA (AUSTRALIA) FRIENDLY SOCIETY APPOINTMENTS.

[For *ac ion* taken see paragraph 181.]

TASMANIAN MEDICAL ACT.

(See para. 204)

MEDICAL COMMISSIONS SENT OVERSEAS BY NATIONAL COUNCIL FOR COMBATING VENEREAL DISEASES.

289. At the request of the National Council for Combating Venereal Diseases, which was sending Medical Commissions to (1) Gibraltar and Malta; (2) Ceylon, Singapore, Colombo, Hong Kong, Borneo and Treaty Ports; and (3) Bahamas, Barbados, St. Vincent, Bermuda, British Guiana, Jamaica, and Antigua, the Branches of the Association in these areas were invited by the Council to co-operate by assisting the Commissions, the function of which is twofold, viz., to help the profession and educate the public. Practically all the Branches have given the desired assistance and the National Council has thanked the Association for the help thus given.

THE COLONIAL MEDICAL SERVICES.

290. In its Reports for 1920, the Council summarised the action taken in placing the views of the Association as to the terms and conditions of service in the Colonial Medical Services before the Departmental Committee appointed in November, 1919, by the Secretary of State, in the appointment of which the Association's previous representations had no doubt considerable influence. The Council in these Reports also stated that it had reason to believe that the report of the Departmental Committee might probably be published in June, 1920. The Association gave evidence before the Departmental Committee as long ago as February, 1920, and the memorandum of that evidence (*B.M.J.* Supplement, April 24th, 1920, page 141) was approved by the A.R.M. 1920 as the policy of the Association in respect of these Services. In spite of representations to the Colonial Office on the subject, and questions in Parliament, there was still no sign, in August, 1920, of the publication of the report of the Departmental Committee. Accordingly, there being still unredressed a very large number of grievances on the part of members of the Association both in the Colonial Services, and retired from those Services, it was decided, in August, 1920, to discontinue to accept for publication in the *British Medical Journal*, advertisements in respect of the Colonial Medical Services.

291. The report of the Departmental Committee was published on September 14th, 1920. A full summary of the report was published in the *B.M.J.* Supplement of September 18th, 1920, and the Council was gratified to find that the report and recommendations of the Departmental Committee endorsed, to a very large extent, the recommendations of the Association.

292. On October 15th, the Association sent to the Colonial Office the letter, dealing in detail with the whole position, published in the *B.M.J.* Supplement of November 27th, 1920. On October 28th also, a deputation consisting of the Chairman of the Dominions Committee, the Chairman of Council, Sir Anthony A. Bowlby (President, Royal College of Surgeons), Lt.-Col. R. H. Elliot, Dr. T. Duncan Greenlees and the Medical and Assistant Medical Secretaries, interviewed Sir Herbert Read and other officials at the Colonial Office. The deputation emphasised the policy of the Association as laid down by the Representative Body and contained in the Association's letter of October 15th, 1920. The deputation was on the whole favourably received, Sir Herbert Read giving an assurance that prompt action was being taken in connection with the recommendations of the Departmental Committee, and this was repeated in a letter received shortly afterwards (see *B.M.J.* Supplement, November 27th, 1920). On November 27th, 1920, the Colonial Office was informed that pending the receipt of their decisions, it had been decided

to resume publication in the *Journal*, if such publication was still desired by the Colonial Office, of advertisements of the Colonial Services. Lord Milner, replied on December 6th, 1920, expressing his gratification, and the advertisements of the Services were resumed in the *Journal*.

293. At its meeting in February, 1921, the Dominions Committee had before it a large number of representations from Oversea Branches and Medical Officers and ex-Medical Officers of various Colonial Services, especially the British Guiana, East African, Leeward Islands and Windward Islands Medical Services and the West African Medical Staff, expressing great dissatisfaction with the terms and conditions of service, and the delay on the part of the Colonial Office in dealing effectively with the recommendations of the Association and of the Departmental Committee. Further urgent representations were accordingly addressed to the Colonial Office emphasising in particular:—(a) the poor advances in the salaries of the middle-service and senior men; (b) the failure to supplement adequately the pensions of retired men; (c) the urgent need for a Medical Department of the Colonial Office; and (d) the lack of proper hospital provision. It was also intimated that unless the Association received a very definite and early assurance that the grievances complained of were being remedied, it would be impossible for the Association to refrain from active dissuasion of medical men who might be thinking of joining the Colonial Services.

294. In a reply dated March 29th, the Colonial Office expressed regret that its expectation of early replies from the Colonial Governments to the circular dispatch sending out the report of the Departmental Committee, had not been fulfilled, but that a telegraphic reminder had been sent to all which had not yet answered and whose opinion was of importance; that in one case the delay was due to the desire of the Governor to obtain a full and complete expression of opinion from the Medical Department, and to the wish of the Head of the Medical Department, in his turn, to ascertain the views of his subordinates who were scattered over a very large tract of country; that as soon as the replies were forthcoming, the question would be carefully considered; and that "the Secretary of State trusts that he will be able to arrive at a definite conclusion, at any rate on the main suggestions of the Committee, without further delay." The matter rests there for the moment, but if early satisfaction is not given by the Colonial Office, the Council feels that it must begin to persuade practitioners not to enter a Service so unsatisfactory.

PENSIONS OF MEDICAL OFFICERS RETIRED FROM THE COLONIAL SERVICES.

295. The Council considers that the whole position in connection with the increase of the pensions granted by various Colonial Governments to retired medical officers in view of the conditions resulting from the War is extremely unsatisfactory. Various increases stated to have been given, were summarised in the Supplementary Report of the Council, 1920. In addition to the fact that in some cases no increases whatever have been given, that statement of increases appears to be misleading, for some of the increases mentioned cannot be taken at their face value. The Council is again raising the whole matter with the Colonial Office.

BRITISH OFFICERS IN THE EGYPTIAN MEDICAL SERVICES.

296. British Members of the Association in the Egyptian Medical Services drew the attention of the Council to the position in which such Officers may find themselves if the present proposals for change of the Government of Egypt are carried into effect, and the matter was taken up by the Association with the Foreign Office. The Council has obtained an assurance that the representations made by the Association as regards the compensation of such Officers as might find their service compulsorily terminated will, if and when the proposals materialise, receive full consideration. The matter is being closely watched in the interests of the members of the Association in the Egyptian Services.

R. A. BOLAM,

Chairman of Council.

APPENDIX I.

British Medical Association.

FINANCIAL STATEMENT FOR THE TWELVE MONTHS ENDING DECEMBER 31st, 1920.

Balance Sheet 31st December, 1920.

Dr.

Cr.

		1920		1919		ASSETS.	
		£	s. d.	£	s. d.		
	To Subscriptions paid in advance...	...	1,410 11 0	By Subscriptions in arrear	1,021 0 6
1,520	" Advertisements ditto	...	1,113 7 10	4,735	...	" Advertisements "	5,333 10 2
293	" Contributions	...	354 15 6	815	...	" Sundry Sales	863 3 6
37	" Engraving	...	31 6 0	298	...	" Furniture and Fittings	430 16 10
171	" Printing Journal	...	439 13 1	1,021	...	" Library	1,463 11 0
1,574	" Paper for Journal	...	1,434 5 0	322	...	" Plant and Type	400 15 7
1,487	" Miscellaneous Printing	...	1,451 13 5	1,468	...	" Paper Stock, &c.	4,717 11 0
31	" Stationery	...	322 7 9	623	...	" Accrued Rent	112 10 0
170	" Repairs	...	1,371 13 9	157	...	" Cash at Office	284 15 0
1	" Legal Charges	...	63 3 0		
603	" Rates, Taxes, Insurance and Electricity	...	618 5 3		
11	" Plant and Type	...	41 10 4	124,516	...	" Investment— " Freehold—220, Strand, Agar Street, and Harvey's Buildings	124,516 6 9
7	" Sundries	...	101 16 3	6,184	...	" £3,200 Bank of England Stock @ 165½	5,295 0 0
42	" Library Books	...	57 1 0	2,784	...	" £6,400 Midland Railway Consolidated 2½% Perpetual Guaranteed " Preferential Stock @ 40½	2,556 0 0
6	" Repairs and Hire of Typewriter Machines	...	13 13 0		
	" Irish Committee	...	13 10 3		
		...	6,883 14 0		
4,110	" Overdraft at Bank	...	11,963 1 3	53	...	" Exhibition Account—Cash at Bank	32 1 3
58	" Exhibition Account Reserve per contra	...	32 1 3		
	" Total Liabilities		
	" Surplus Account—		
187,110	Balance on January 1st, 1920	...	139,415 10 10		
2,304	Less excess of Expenditure over Income	...	12,065 11 7		
		...	127,349 18 3		
		...	£148,531 14 7		

(The above Assets do not include the unexpended Balances of Capitation Grants held by the various Branches.)

Committees—continued.

	1920.		1919.	
	£	s. d.	£	s. d.
Finance Committee—				
Railway Fares	80	12 10	49	15 6
Printings, &c.	165	2 0	68	8 6
Hospitals Committee—				
Railway Fares	107	16 4	65	19 3
Printings, &c.	78	15 6	10	9 0
Insurance Ads Committee—				
Railway Fares	591	10 8	993	11 4
Printings	477	16 9	1,281	3 6
Stamps	18	19 0	50	19 6
Lozenges	29	0 5	122	5 9
Journal Committee—				
Railway Fares	54	3 5	32	19 0
Printings	47	13 6	38	1 6
Medical Political Committee—				
Postages	307	4 9	165	13 1
Railway Fares	132	6 0	208	9 10
Printings	459	10 9	273	11 6
Ministry of Health Committee—				
Railway Fares	377	0 3	82	17 0
Printings	90	16 0	57	6 6
Naval and Military Committee—				
Railway Fares	66	12 7	108	18 11
Printings	55	18 0	96	15 6
Office Committee—				
Fees	204	0 0	—	—
Printings	39	6 6	—	—
Organisation Committee—				
Railway Fares	94	0 7	125	1 2
Printings, &c.	1,258	7 6	124	11 6
Postages and Addressing	—	—	91	11 6
Framed Notices to Medical School	—	—	—	—
Travelling	36	3 0	21	1 0
Maps and Globes	75	3 1	17	18 6
Office Staff Superannuation Fund Committee—				
Printings	2	1 0	692	6 8
Parliamentary Elections Committee—				
Railway Fares	—	—	9	11 4
Printings	—	—	11	2 6
Public Health Committee—				
Railway Fares	102	18 1	102	1 1
Printings, &c.	40	6 0	28	3 0
Science Committee—				
Railway Fares	41	15 0	59	19 9
Printings	4	5 0	55	1 6
Lectures	288	8 11	—	—
Scottish Committee—				
Special Grants	—	—	54	6 4
Printings, &c.	—	—	38	9 0
Railway Fares	—	—	150	3 9
Punitive Committee—				
Late Clerk's Salary and Pensions	—	—	136	0 10
Scottish Medical Secretary	—	—	15	19 4
—	—	—	134	6 2
Joint Committee on Minimum Salaries for Public Appearances—				
Printings	14	19 6	6	7 6
Railway Fares	—	—	—	—
Welsh Committee—				
Railway Fares	17	14 9	15	5 8
Printings	3	18 6	3	0 0
Carried forward	49,396	3 0	49,596	11 3

(See Profit and Loss Account.)

General Association Expenses.

	1920.		1919.	
	£	s. d.	£	s. d.
Architects' Fees	177	7 0	—	—
Auditors' Fee	282	0 0	157	10 0
Bank Charges	66	16 4	62	11 3
Interest on Overdraft	110	0 8	10	0 0
Donation to Charing Cross Hospital	2	2 0	2	2 0
The Faculty of Insurance, Subscription and Entrance Fee	12	12 0	12	12 0
Medical Director's	593	16 10	593	16 10
Legal Expenses	383	17 11	2,018	3 4
Do. Do. Prati Case	2	3 6	22	8 8
Repairs and Hire of Typewriter Machines	322	0 5	292	13 8
Office—Petty Cash	40	3 2	39	11 9
Parliamentary Papers	473	0 0	225	0 0
Research Scholarships	36	0 0	115	0 0
Scientific Grants	60	13 4	30	0 0
Stamping Subscription Receipt Books	602	12 4	71	5 0
Dr. J. Macdonald's Visit to S. Africa	151	9 0	105	0 0
Two Gold Medals (Drs. Chavasse and Beake)	—	—	100	0 0
Memorial to the late Mr. City Edleston	21	0 0	110	0 0
History of the Association (on account)	100	0 0	100	0 0
Gratuity to deceased clerk's wife	—	—	41	6 9
B.M.A. Staff Luncheon Room	—	—	21	18 6
Grant to Mrs. C. L. Taylor	—	—	—	—
Sanities	67,590	2 8	65,472	17 11

Central Meetings Expenses.

	1920.		1919.	
	£	s. d.	£	s. d.
REPRESENTATIVE MEETING—				
Railway Fares	511	12 5	631	3 4
Printings	256	1 0	434	13 0
Analysis	—	—	30	15 0
Sanities	—	—	818	6 3
COLLECT—				
Railway Fares	84	3 9	89	3 9
Printings	970	8 6	1,008	19 0
Sanities	—	—	32	15 0
ANNUAL MEETING—				
Sectional Expenses	1,834	12 3	1,947	17 9
RAILWAY FARES, SECRETARIES' CONFERENCE				
Sectional Expenses	—	—	279	7 10
Railway Fares	173	19 4	1	9 6 0
Sectional Expenses	2,825	18 0	3,964	9 9

Committees.

	1920.		1919.	
	£	s. d.	£	s. d.
Arrangements Committee—				
Railway Fares	11	19 3	109	6 5
Printings, &c.	10	5 0	123	11 6
Central Ethical Committee—				
Railway Fares	67	12 3	59	11 9
Printings, &c.	636	6 0	108	16 0
Postages	10	10 7	—	—
Advertising Appointments	—	—	415	8 10
Central Medical War Committee—				
Railway Fares	82	3 6	—	—
Printings	437	7 11	—	—
Typists and Clerical Assistance and Assistants	10	0 0	—	—
Postages	66	5 0	—	—
Stationery	—	—	625	16 5
Dominions Committee—				
Railway Fares	11	1 8	41	6 11
Printing	35	2 6	24	9 6
Election Returns Committee—				
Railway Fares	9	9 9	—	—
Printings	4	18 6	14	8 3
Carried forward	41,041	19 11	44,106	12 4

Abstract C.]

Central Premises Expenses.

	1919.		1920.	
	£ s. d.	£ s. d.	£ s. d.	£ s. d.
Cleaning Offices	12 0 8	...
Coals, Coke and Wood	235 0 4	...
General Repairs, Upkeep, and Alterations	3,907 7 0	...
Rates, Taxes, Insurance, and Electricity	2,618 11 8	...
	£2,813 8 5		£7,572 19 8	

Abstract D.]

Central Printing, Stationery and Postage Expenses.

	1919.		1920.	
	£ s. d.	£ s. d.	£ s. d.	£ s. d.
General Printing	375 4 10	...
Office—General Postage
Finance Department	522 18 0	...
Medical Department	435 16 7	...
Stationery	1,088 6 11	...
	£2,837 18 9		£2,402 6 4	

Abstract E.]

Central Staff Expenses.

	1919.		1920.	
	£ s. d.	£ s. d.	£ s. d.	£ s. d.
Financial Secretary and Business Manager	800 0 0	...
Clerical Staff, Financial Department	4,291 11 5	...
Less Proportion of Salaries debited to Journal Account	4,198 1 7	...
	1,776 15 3	2,421 6 4	5,091 11 5	2,363 8 0
Medical Secretary	1,475 0 6	...
Deputy Medical Secretary	989 12 9	...
Late Deputy Medical Secretary	—	...
Assistant Medical Secretary (1)	812 10 0	...
Do, (2)	687 10 2	...
Clerical Staff, Medical Department	3,369 9 11	...
Contribution to Office Staff Superannuation Fund	7,404 3 4	...
TRAVELLING EXPENSES:—	555 0 0	416 1 10
Finance Department	4 0 0	...
Medical Department	157 13 10	...
Fidelity Guarantee and Employers Liability Insurances	59 17 9	...
Intelligence Department	165 4 6	...
	£8,935 1 7		£11,791 5 8	

Abstract F.]

Library Account.

	1920.		1921.	
	£ s. d.	£ s. d.	£ s. d.	£ s. d.
To Balance	1,721 10 7	...
Purchase of Books	92 5 5	...
Binding Books	46 11 0	...
Index Cards	3 4 0	...
Salary—Librarian	451 13 5	...
Librarian's Clerk	276 1 9	...
Printing and Postage of Circulars, &c.	2 6 0	...
Subscriptions to H. K. Lewis's Library	25 0 0	...
Amount written off for Depreciation
Balance as per Balance Sheet
	£2,421 12 2		£2,421 12 2	

TRUST FUNDS FOR WHICH THE COUNCIL OF THE BRITISH MEDICAL ASSOCIATION ACT AS TRUSTEES.
Office Staff Superannuation Fund.

INCOME.		EXPENDITURE.	
1920.	£ s. d.	1920.	£ s. d.
Dec. 31.	Contribution from Association	Dec. 31.	Amount refunded to retired members
	Payments by Members of Staff		Income Tax on Interest
	Interest on Investments and Deposit Account		Balance carried to Capital Account
	£1,085 8 10		£1,055 8 10

Accounts for the Year ending December 31st, 1920.

Capital Account for the Year ending 31st December, 1920.	
1920.	£ s. d.
Dec. 31.	—Balance brought down from 1919
	from Income and Expenditure Account
	£7,980 16 4

Dr.

To Capital Account Balance	£ s. d.	Cr.	£ s. d.
	7,980 16 4		7,980 16 4

Balance Sheet, 31st December, 1920.

LIABILITIES.		ASSETS.	
£ s. d.	£ s. d.	£ s. d.	£ s. d.
To Capital Account Balance	7,980 16 4	By Cash with Bankers—Current Account	57 0 0
		Deposit	57 0 0
		£800 Cape of Good Hope 3 per cent. Inscribed Stock @ 58	462 17 6
		£100 Bristol Corporation 5½ per cent. Redeemable Stock @ 57	57 0 0
		£1,150 Midland Railway Consolidated 2½ per cent. Perpetual Guaranteed Preferential Stock @ 40	462 17 6
		£100 Midland Railway 2½ per cent. Debenture Stock @ 111	111 5 0
		£200 New Zealand 4 per cent. 1920 Consolidated Stock @ 82	164 0 0
		£300 New Zealand 3 per cent. 1915 Inscribed Stock @ 57	171 0 0
		£200 Furness Railway Consolidated 3 per cent. Preferential Stock 1881 @ 52½	105 0 0
		£250 Bank of England Stock @ 175½	437 17 6
		£100 India Stock 3 per cent. @ 4½	450 0 0
		£150 Stockton-on-Tees Corporation 3 per cent. Redeemable Stock @ 61½	92 0 0
		£300 North-Eastern Railway Company 3 per cent. Debenture Stock @ 70	210 0 0
		£600 Lancashire and Yorkshire Railway 3 per cent. Consolidated Preferential Stock @ 45	270 0 0
		£700 London and North-Western Railway 3 per cent. Perpetual Debenture Stock @ 51	357 0 0
		£100 Furness Railway 1 per cent. Preferential Stock 1898 @ 48½	48 17 6
		£1,265 38. 00. War Loan 5 per cent. 1920-17 @ 83	1,048 10 2
		£600 War Loan 5 per cent. 1920-17 @ 83	498 0 0
		£100 New South Wales Government 5½ per cent. Inscribed Stock 1922-1927 @ 92	92 0 0
		£500 National War Bonds 5 per cent. 1st Series 1927 @ 93	465 0 0
		£600 War Loan 5 per cent. 1920-17 @ 83	498 0 0
			£7,980 16 4

Francis Fowke Bequest.
£700 Midland Railway Consolidated 2½% Perpetual Guaranteed Preferential Stock.

1920.		1920.	
Jan. 1.	To Balance brought over from 1919	Dec. 31.	By Income Tax
	Interest on Deposits and Dividends		Balance, Cash at Bank, Current and Deposit Accounts
	£187 19 4		£187 19 4

Fotherby Bequest.

1920.	£ s. d.								£ s. d.
Jan. 1.	To Balance brought over from 1919	63 5 1
Dec. 31.	" Interest	2 2 5
									<u>£54 7 6</u>
Dec. 31.	By Income Tax
	" Balance, Cash at Bank, Current and Deposit Account	63 18 6
									<u>£54 7 6</u>

Stewart Fund.

£579 Caledonian Railway 4 per cent. Debenture Stock.

1920.	£ s. d.								£ s. d.
Jan. 1.	To Balance brought over from 1919	48 19 6
Dec. 31.	" Interest and Dividend	17 11 2
									<u>£65 10 8</u>
Dec. 31.	By Award to Miss Henriette Chick, D.Sc.
	" Ingrossing Certificate
	" Income Tax
	" Balance, being Cash at Bank	11 4 0
									<u>£65 10 8</u>

Middlemore Fund.

£665 15s. 4d. North British Railway 3 per cent. Debenture Stock.

1920.	£ s. d.								£ s. d.
Jan. 1.	To Balance brought over from 1919	43 14 0
Dec. 31.	" Interest and Dividend	15 4 2
	" Balance (overdrawn)	12 14 10
									<u>£71 13 0</u>
Dec. 31.	By Award to Harry Moss Trajanar, M.D., F.R.C.S.E., D.P.H.
	" Advertising
	" Adjudicator's Fees
	" Ingrossing Certificate
	" Income Tax
									<u>£71 13 0</u>

Having examined the Balance Sheet, dated 31st December, 1920, and Accounts with the books and vouchers of the Association, except as regards the Irish Committee Account, and having received all the information and explanations we have required, we report that the Balance Sheet is, in our opinion, properly drawn up so as to exhibit a true and correct view of the state of the affairs of the Association according to the best of our information and the explanations given to us and as shown by the books of the Association.

We have verified the Investments of the Association on General Account and on account of the Trust Funds shown and of the Office Staff Superannuation Fund, and we have verified the possession by the Bankers of the Association of the Deeds of the Freehold Property.

G. E. HASLIP, M.D.,
Treasurer.
 W. E. WARNE,
Financial Secretary and Business Manager.

G. FREDERICK, WATERHOUSE & CO.,
Chartered Accountants, 5, Frederick's Place, Old Jewry, London, E.C.4.
March 2nd, 1921.

Remittances received on behalf of Medical Benevolent Funds for the Year ending 31st December, 1920.

Royal Medical Benevolent Fund.	
1920.	£ s. d.
Dec. 31. To Subscriptions and Donations	860 11 0
Dec. 31. By Cheques sent to Treasurer	...
	590 11 0
Royal Medical Benevolent Fund Society of Ireland.	
1920.	£ s. d.
Dec. 31. To Subscriptions and Donations	544 8 0
Dec. 31. By Cheques sent to Treasurer	...
	544 8 0
Royal Medical Benevolent Fund Society of Ireland.	
1920.	£ s. d.
Dec. 31. To Subscriptions and Donations	32 14 6
Dec. 31. By Cheques sent to Treasurer	...
	32 14 6

Central Emergency Fund.

FOR WHICH THE MEDICO-POLITICAL COMMITTEE OF THE BRITISH MEDICAL ASSOCIATION ACT AS TRUSTEES.

Financial Statement for the Year ending 31st December, 1920.

1920.		1920.	
Jan. 1. To Balance from 1919—	£ s. d.	Dec. 31. By Income Tax paid	£ s. d.
Cash at Bankers	471 10 7	Balance 31st December, 1920—	...
£ 100 National War Bonds	500 0 0	£ 60 National War Bonds	...
War Saving Certificates	287 10 6	10 1/2 Year Treasury Bonds	...
	1,258 10 3	War Saving Certificates at Cost	...
Subscriptions and Donations from January 1st to December 31st, 1920	1,319 0 7	Cash at Bankers—Current Account	...
Deposit Interest and Dividends received	145 17 6	Deposit	...
	2,722 18 6		1,502 15 4
	<u>£1,506 19 4</u>		<u>£1,506 19 4</u>

We have compared the above four accounts with the Books and Vouchers of the Funds relating thereto and find them correct. We have verified the Investments of the Funds and the Balances held by the Bankers at the 31st December, 1920.

G. E. HASLIP, M.D.,
Treasurer.

W. E. WARNE,
Financial Secretary and Business Manager.

PRICE, WATERHOUSE & CO.,
5, Frederick's Place, Old Jewry, London, E.C.4.
2nd March, 1921.

APPENDIX II.

(DRAFT) MEMORANDA FOR THE GUIDANCE OF THE REPRESENTATIVE BODY OF THE BRITISH MEDICAL ASSOCIATION IN CONNECTION WITH THE APPROVAL OF CORPORATE MEMBERS AND NOMINATING BODIES (*i.e.*, AFFILIATION OF OUTSIDE BODIES TO THE ASSOCIATION).*

See page 119 of Report of Council, para 126.

INTERPRETATIONS.

1. In these Memoranda—

A.B.=Applicant Body, *i.e.*, an association or body of persons desiring to become a corporate member of the British Medical Association or to be empowered to nominate a nominated member (By-law 10 (1)).

B.M.A.=British Medical Association.

C.M.=Corporate Member.

N.B.=Nominating Body.

N.M.=Nominated Member.

R.B.=Representative Body of British Medical Association.

PROCEDURE.

2. Each application by an association or body of persons desiring to become a C.M. or to be empowered to nominate a N.M. shall be in writing signed by the Secretary or other responsible officer of the A.B., and transmitted to the B.M.A. at the Head Office (By-law 10 (1)), and may be in the following form or in a form to the like effect:—

FORM OF APPLICATION BY AN ASSOCIATION OR BODY OF PERSONS DESIRING TO BECOME A CORPORATE MEMBER OR TO BE EMPOWERED TO NOMINATE A NOMINATED MEMBER OF THE B.M.A.

(Private and Confidential).

To the British Medical Association,
429, Strand,
London, W.C.2.

(1) I am instructed by the (a) of the (b) of (address) to inform you that the (b) desires to become a Corporate Member (*or*, to be empowered to nominate a Nominated Member) of the British Medical Association, as from 192

(2) There are enclosed herewith copies of the Memorandum of Association, Articles and By-laws (*or*, instrument of foundation, regulations, etc., as the case may be), and other necessary particulars in respect of the constitution and administration of the (b) and the conditions of membership thereof.

(3) The membership of the (b) on January 1st last was, made up as follows

(4) The (b) is duly registered under the of as a

(5) The present application is made as the result of a decision to that effect by the (a) of the (b) on 192 That decision was arrived at by votes in favour, as compared with votes against

(6) A statement (signed by me) of the mutual rights and privileges, terms and conditions, proposed, is enclosed herewith.

Signature

Office held

N.B.—The application requires to be signed by the Secretary or other responsible officer of the

*The Articles and By-laws referred to in these draft Memoranda are the draft Articles and By-laws appended to the report of the Council (*B.M.J.* Supplement, March 5th, 1921, page 56).

applicant body and transmitted to the Association at the Head Office (By-law 10 (1)).

(a) Insert name of Council or other governing or representative body of the A.B.

(b) Name of A.B.

3 Each application shall stand referred by the Council to the Organisation and Finance Committees, and these Committees shall, in joint meeting, consider the application and shall report thereon to the Council.

4. At any stage, if and when in the opinion of the Council such consultation is desirable, it shall be the duty of the Council to consult with the A.B. as to the question of the proposed rights and privileges, terms and conditions, with a view to the same being settled on mutually satisfactory lines.

5. Each application shall be considered by the Council, on the report of the Organisation and Finance Committees, at a meeting of which a notice, specifying that such consideration will form part of the business thereat, shall be sent to every member of the Council. Such consideration shall include a consideration of the Memorandum of Association or instrument of foundation and the regulations of the A.B., of the question whether the application appears to be within the powers of the A.B., and as to whether the application is made with the concurrence of a substantial number of the members of that body (By-law 10 (2)).

6. The Council shall report to the next Meeting of the R.B. upon each application considered by the Council, and no application shall be considered by the R.B. except upon the report of the Council (By-law 10 (3)). The report of the Council shall include a recommendation as to whether the R.B. should approve the A.B. as a C.M. (Art. 6) or as a N.B. (Art. 7), or withhold its approval, and whether conditionally or unconditionally, and may contain such observations relating to the application as the Council may think fit.

GENERAL CLASSIFICATION OF POSSIBLE APPLICANT BODIES.

7. In addition to the classification into "corporate bodies" and "unincorporated associations or bodies of persons," mentioned in Articles 6 and 7, there shall be recognised by the B.M.A. the following classification of possible applicant bodies:—

CLASS (A) BODIES: Outside bodies composed entirely of members of the medical profession, and admission to whose membership is open only to members of the medical profession.

CLASS (B) BODIES: Outside bodies whose membership is open to other than members of the medical profession, but which have for one or more of their objects the promotion of medical or any allied science or of the welfare of the medical or any allied profession.

8. It shall rest with the R.B. to decide in each individual case what privileges shall or shall not be given, and if given, upon what terms and conditions, to a body desiring to become a corporate member of the B.M.A., or to be empowered to nominate a nominated member thereof (Article 8 and By-law 10 (5)).

9. The R.B. may in each case give or withhold its approval, and shall not be bound to state any reasons for any such action (By-law 10 (4)).

10. In deciding the privileges, terms and conditions upon which an individual A.B. shall, if at all, be admitted (whether as a corporate member or a nominating body, as the case may be), the R.B. shall have regard to whether the body in question belongs to Class (A) or Class (B), and to the other circumstances of the individual case.

11. The following is the list of possible rights and privileges, and terms and conditions, in respect of a corporate member or nominating body. Which of those rights and privileges, and terms and conditions, shall apply in any individual case, shall be decided by the R.B. in respect of that case.

Privileges marked "MED" can be given by the R.B. in the case of a Class (A) body only.

POSSIBLE RIGHTS AND PRIVILEGES, AND TERMS AND CONDITIONS, IN RESPECT OF A CORPORATE MEMBER OR NOMINATING BODY ON THE ONE HAND, AND THE B.M.A. ON THE OTHER.

(1) AS REGARDS THE REPRESENTATIVE BODY OF THE BRITISH MEDICAL ASSOCIATION.

(MED) (a) Right of a C.M. or N.B. to Direct Representation.

Right to elect or appoint one Representative (and one or more Deputy-Representatives), with an additional Representative (and Deputy-Representative(s)) for each 500 members of the C.M. or N.B. after the first 500. The Representative(s) and Deputy-Representative(s) to be registered medical practitioners, and to be elected or appointed (so far as possible) so as to come into office at the time specified by the By-laws of the B.M.A. as regards Representatives of the B.M.A. Constituencies, but the mode of election or appointment to be in the discretion of the C.M. or N.B.

(MED) (b) Right of C.M. or N.B. to bring forward Motions.

The same terms and conditions to apply as are laid down by Article 34 and By-law 42 in respect of Divisions and Branches of the Association.

(MED) (c) Right of Representative of C.M. or N.B. to Vote.

Each Representative of the C.M. or N.B. to have one vote in a vote taken by show of hands, division or roll-call, but no vote in a vote taken by card (By-law 44).

(d) Right to be heard by Deputation.

(e) Right of Notice of Certain Proposals.

Right of C.M. or N.B. to receive a copy of every report, resolution or proposal on any subject affecting the honour or interests of those whom the C.M. or N.B. represents.

(2) AS REGARDS GENERAL MEETINGS OF THE B.M.A.

(a) Right of a C.M. or N.M. to share in requisition for General Meeting (Arts. 23-5).

(b) Receipt by a C.M. or N.M. of Notice of General Meeting (Art. 26).

(c) Right of C.M. or N.M. to attend or be represented at General Meeting.

Each N.M. shall have this right. Each C.M. shall be entitled to be represented by an official thereof duly authorised by resolution thereof to act as such representative (By-law 32 (1)).

(d) Right of C.M. or N. M. to Vote.

Each N.M. or authorised official of a C.M. (see foregoing), to be entitled to vote (By-law 32 (2)).

(3) AS REGARDS THE COUNCIL OF THE B.M.A.

(MED) (a) Right of C.M. or N.B. to Direct Representation.

Right of C.M. or N.B. to elect or appoint one member of Council. The member to be a registered medical practitioner, and to be elected or appointed (so far as possible) so as to come into office at the close of an A.R.M. (By-law 54 (3)). The mode of election or appointment to be in the discretion of the C.M. or N.B.

(MED) (b) Right of C.M. or N.B. to bring forward Motions.

The right to introduce motions. Such introduction to be according to the conditions laid down by the Standing Orders of the Council.

(MED) (c) Right to Vote.

A Member of Council elected or appointed by a C.M. or N.B. to have voting power.

(d) Right to be heard by Deputation.

(e) Right of Notice of Certain Proposals.

Right of C.M. or N.B. to receive a copy of every report, resolution or proposal on any subject affecting the honour or interests of those whom the C.M. or N.B. represents.

(4) AS REGARDS STANDING COMMITTEES OF THE B.M.A.

(a) Right of C.M. or N.B. to direct Representation.

Right of C.M. or N.B. to elect or appoint one or more members (whether or not members of the B.M.A.) to such Standing Committee or Committees of the B.M.A. as may be deemed appropriate in the particular case. Such Committee member or members to be elected or appointed (so far as possible) so as to come into office at the times specified by the By-laws of the B.M.A. as regards those members of the Standing Committees elected by the R.B. and Council of the B.M.A. The mode of election or appointment to be in the discretion of the C.M. or N.B.

(b) Right to Vote.

A member of a Standing Committee of the B.M.A. elected or appointed by a C.M. or N.B. to have voting power.

(c) Right of Notice of Certain Proposals.

Right of C.M. or N.B. to receive a copy of every report, resolution or proposal on any subject affecting the honour or interests of those whom the C.M. or N.B. represents.

(d) Right to be heard by Deputation.

(MED) (5) ANNUAL SCIENTIFIC MEETINGS OF THE B.M.A.

Right of members of the C.M. or N.B., who are members of the R.B., and also such other members of the C.M. or N.B., as are resident outside the United Kingdom, to attend the Annual Scientific Meetings of the B.M.A.

(6) BRITISH MEDICAL JOURNAL.

(a) "Important Notices."

Right of the C.M. or N.B. to apply for the use of the "Important Notices" column of the *British Medical Journal*, in respect of any appointment to which the C.M. or N.B. takes exception. The decision as to whether a Notice in any particular case shall be inserted shall rest with the Council of the B.M.A.

(b) Advertisements.

Right of the C.M. or N.B. as regards any advertisement offered to or appearing in the *British Medical Journal*, to which the C.M. or N.B. takes exception, to apply for its refusal or amendment. The decision as to the action to be taken as regards any individual advertisement to rest with the Council of the B.M.A.

(c) Notices and Reports of Meetings.

Right of the C.M. or N.B. to have published in the *British Medical Journal*, notices or reports of meetings thereof, subject to the discretion of the Editor of the *Journal* in respect of each individual notice or report.

(d) Supply of British Medical Journal.

In the case of a C.M. or N.B. outside the United Kingdom, supply in bulk weekly, carriage free, of a specified number of copies of the *British Medical Journal* (or of the *B.M.J. Supplement*).

Right of the Secretary of a C.M. or N.B. within the United Kingdom to receive weekly an official copy of the *British Medical Journal*.

(7) CENTRAL CONFERENCES AND DEPUTATIONS ORGANISED BY B.M.A.

Right of the C.M. or N.B. to representation in central conferences and deputations organised by the B.M.A. in respect of matters affecting the honour or interests of those whom the C.M. or N.B. represents, subject to approval by the Council in the case of each such conference or deputation.

(MED) (8) CENTRAL STAFF AND HEAD OFFICE OF B.M.A.

(a) *Right to Services of Staff.*

Right of the C.M. or N.B. to the use of the services of the staff of the Head Office of the B.M.A.

(b) *Right to use of Library.*(c) *Right to use of Council or Committee Room.*

Right of C.M. or N.B. to the use of the Council Room or of a Committee Room of the B.M.A., if vacant.

All these rights (a), (b), and (c) to be subject to the control of the Office Committee of the B.M.A. or other Committee concerned.

(MED) (9) INDIVIDUAL MEMBERSHIP OF C.M. OR N.B., AND OF B.M.A.

Individual member of C.M. or N.B., to be (if otherwise eligible) free to join as, or remain, an individual member of B.M.A., and *vice versa*.

(10) BRANCHES OF B.M.A.

(Subject in each case to the Rules of the Branch.)

Rights of a Local C.M. or N.B., i.e., one within the area of a Branch or neighbouring Branches of B.M.A.

(MED) (a) *Right to elect or appoint one Representative (being an ordinary Member of B.M.A.) as Member of the Branch Council.* The member to be elected or appointed (so far as possible) so as to come into office at the same time as the Branch Council. The mode of election or appointment to be in the discretion of the C.M. or N.B.

(MED) (b) *Right of C.M. or N.B. to bring forward Motions.*

Any such motion to be in the hands of the Honorary Secretary of the Branch in accordance with the Standing Orders of the Branch Council.

(MED) (c) *Right to Vote.*

A member of the Branch Council elected or appointed by a C.M. or N.B. to have voting power.

(d) *Right to be heard by Deputation.*

Any such deputation to be limited as the Branch Council may determine from time to time.

(e) *Agenda.*

Right to receive a copy of every report, resolution or proposal affecting the honour or interests of those whom the C.M. or N.B. represents.

(f) *Seats on Committees (Standing or ad hoc).*

Right of C.M. or N.B. to elect or appoint one or more members (whether or not members of B.M.A.) to such Standing Committee or Committees of the Branch Council, as may be agreed with the Branch Council. Such Committee member or members to be elected or appointed (so far as possible), so as to come into office at the times specified in the Rules of the Branch. The mode of election or appointment to be in the discretion of the C.M. or N.B.

(g) *Deputations and Conferences.*

Right of the C.M. or N.B. to representation at conferences and deputations organised by the Branch Council in respect of subjects affecting the honour or interests of those whom the C.M. or N.B. represents.

(h) *Right to use any Library or Club formed by Branch: Committee Rooms: Offices.*

Right of the members of the C.M. and N.B. to avail themselves of any such benefits, on such terms and conditions as may be agreed with the Branch Council.

(i) *Reciprocity.*

The Branch of the B.M.A. to obtain such privileges or rights as may be mutually agreed upon, including any or all of the above, on terms and conditions mutually determined from time to time.

(11) PRIVILEGES OR RIGHTS TO BE ACCORDED TO B.M.A.

Such privileges or rights for the B.M.A. as may be mutually agreed upon.

(12) GENERAL.

(a) *Advertising fact of Relationship to B.M.A.*

Right of C.M. or N.B. to announce publicly the fact of its relationship to B.M.A. and to use the style "Federated (or affiliated) to the B.M.A."

Notice of the relationship to be published by the B.M.A. Name of C.M. or N.B. (and N.M.) to be included in Annual List of Members of B.M.A. (By-law 11).

(b) *To be supplied by B.M.A.*

The B.M.A. to supply to the C.M. or N.B., post free, copies of all circular letters and other communications which concern the honour or interests of those whom the C.M. or N.B. represents and are referred to the Divisions of the B.M.A. (in so far as the same do not appear in the *British Medical Journal*).

(c) *Annual and Supplementary Reports of Council of B.M.A.*

The C.M. or N.B. to have the right of forwarding to the Council of the B.M.A., with a view to inclusion as an appendix in the Annual or Supplementary Report of that Council, draft paragraphs dealing with the work of the C.M. or N.B.

(13) SUBSCRIPTION BY C.M. OR N.B. TO B.M.A.

There shall be paid annually by the C.M. or N.B. to the B.M.A. such sum as may from time to time be mutually determined.

OPINION OF COUNSEL AS TO CERTAIN QUESTIONS
RAISED WITH HIM BY ORGANISATION COMMITTEE
IN CONNECTION WITH THE DRAFT
MEMORANDA.

I regard the proposed "Rules" as merely memoranda formulated by the Representative Body for their own guidance in carrying out the new duties which will be imposed upon that Body if and when the "Federation" Articles and By-laws are adopted. Those Articles and By-laws clearly involve material alterations of the constitution and policy of the Association, and fall within the provisions of existing Article 30 and By-law 40 as to a two months' publication. The "Rules" or "Memoranda" (as I should prefer to call them) do not themselves involve such alterations; they will be merely consequential on such alterations already made. In my opinion there is no obligation to publish them under the existing Regulations referred to, nor is there any such obligation as to any proposed amendments to them. It is probably most wise to publish the Rules (as is proposed); but if amendments to them are proposed in accordance with the usual practice of the Representative Body as to amendments to ordinary resolutions (as to which practice the Articles and By-laws are silent), I think that such amendments would be permissible and would be binding if carried.

I think that the Rules or Memoranda should be kept as elastic as possible and that the Representative Body ought not to tie their own hands more than is necessary. In settling them I have kept this in view, but I have hesitated to interfere with the considered opinions of the Organisation Committee on subjects with which they are so familiar.

T. R. COLQUHOUN DILL.

Lincoln's Inn.

7th April, 1921.

APPENDIX III.

MEMORANDUM ON THE REPORT OF THE CONSULTATIVE COUNCIL ON MEDICAL AND ALLIED SERVICES.

1. The establishment of a Ministry of Health (largely in accordance with the wishes and suggestions of the British Medical Association) justifies the assumption that the State proposes to undertake that there shall be available for the community a complete systematised provision for the preservation of the health of the public and for its medical treatment. This assumption underlies the Reports of the various Consultative Councils and the Report (A.R.M. 23) of the Ministry of Health Committee which was presented to the Representative Body.

2. It is recognised that the Report of the Consultative Council on Medical and Allied Services alluded to hereafter as "the Report" is an interim report only, and that there are many matters, particularly those relating to finance and administration, that are not dealt with therein, or are referred to in a very vague or tentative fashion. These matters are, however, in the opinion of the Council, of such importance that they ought not to be ignored in the consideration which the Association and the profession give to the subject matter of the Report, though they will have to be dealt with in detail at a later stage. A full synopsis of the Report (English and Welsh), reprinted from the *B.M.J.* of May 29th, 1920, will be found in Sub-Appendix B, and it is intended here only to draw attention particularly to some points of fundamental importance. These are grouped under the following headings:—

- A. Domiciliary Attendance.
- B. The Relation of Curative and Preventive Medicine.
- C. The Primary Health Centres.
- D. The Communal Services.
- E. The Secondary Health Centres.
- F. The Relation of Practitioners to Administration.
- G. The Composition and Powers of the Local Health Authority.

PRINCIPLES UNDERLYING THE REPORT.

3. But before dealing *seriatim* with these more fully it is considered advisable to enumerate the principles which appear to underlie the Reports of the Consultative Councils:—

(i.) That any scheme of services must be available for all classes of the community (par. 7 of the Report).

(ii.) That the general practitioner should participate in the three forms of service (a) Domiciliary, (b) Institutional, and (c) Communal (pars. 11, 48, 66).

(iii.) That preventive and curative medicine cannot be separated on any sound principle, and must be brought together in close co-operation (par. 6).

(iv.) That domiciliary service should under ordinary circumstances be carried out either at the home of the patient or at the doctor's surgery, as at present (par. 19).

(v.) That Primary Health Centres are essential to an efficient general practitioner Service, both urban and rural, and that general practitioner treatment should be centred on these (par. 45).

(vi.) That the general practitioner would attend at the Primary Centre such of his patients as require hospital treatment, irrespective of their status, though under varying terms and conditions of service (par. 47).

(vii.) That the three methods of payment of the general practitioners are: (1) by the patient, (2) through some method of insurance, or (3) by the Health Authority (par. 47).

(viii.) That the consultants attached to Secondary Centres should be part-time officers paid on a time basis, and should also visit the Primary Centres at fixed intervals; visits to patients' homes and special visits to the centres would be met by extra fees (pars. 62, 63).

(ix.) That a doctor would be able to arrange for his patient to be transferred to a Primary Health Centre under his care (par. 19). Secondary Centres would receive cases referred to them from Primary Centres (par. 1).

(x.) That the staffs of Secondary Hospitals should be elected by a Committee of Selection formed by representatives of (a) the Hospitals; (b) the Health Authority; (c) the University; and (d) the local doctors, on which the medical members would form a majority (pars. 67 and 68).

(xi.) That services should be administered by a Health Authority established in each area on which there should be an effective representation of the medical profession (par. 98).

These principles, as well as some others, are further dealt with in the appropriate paragraphs of this memorandum.

In these paragraphs there are set out the essential statements of the Report on the subjects dealt with, together with any opinion on the matter that has been expressed by the Council of the Association or Representative Body. This has been done for the information of the Divisions, but it should be understood that such opinions are not binding upon the Divisions in any way, nor are they intended to restrict the freedom of the Divisions in any answers they may give to the questions asked, or in any remark they may wish to make on the matters under consideration.

4. It is proposed both by the Report and by the Council that the whole country be divided into suitable administrative health areas, each having its Local Health Authority. Each Local Health Authority will be responsible for seeing that medical services, preventive and curative, are available for every person in its area. The services—preventive and curative in each case—are divided into: A. Domiciliary, B. Institutional, and C. Communal. In discussing each division regard must be had to the three groups into which the population falls:—(a) those for whom provision must be made without the requirement of any personal contribution; (b) those who may be expected to make some contribution by an insurance scheme or otherwise; and (c) those who are able to make provision for themselves. To which of these groups any individual should be assigned may well vary according to the particular service required. Finally, under each division it is necessary to bear in mind (1) the administration (2) the availability of the services to each group of the population, and (3) the methods of remuneration of the medical profession.

A. Domiciliary Attendance.

(Questions 1-3.)

5. The Report states that "domiciliary service is the first element in any scheme of systematised medical services," that this service "must be available for all classes of the community under conditions to be hereafter determined," and that availability "does not mean the services are to be free."

6. The Report does not propose any necessary or immediate change in the provision of domiciliary treatment. If and when such changes are proposed, resolutions which the Ministry of Health Committee has already passed with regard to the attitude of the Association towards such changes will come up for consideration.

7. The Welsh Consultative Council's Report states "that in some form or other for every household in the land a family doctor should be available" (par. 6).

8. In the English Report certain additional facilities are suggested to aid domiciliary service, such as the power to summon consultant or specialist assistance to the patient's house, and the provision of nurses for all illnesses and all persons when the doctor deems these to be necessary.

9. The Council and Representative Body have expressed the opinion that "general practitioner attendance and treatment is the only foundation on which any systematic provision of other kinds of treatment can properly be based; and that, generally speaking, it should be only on the recommendation of a general practitioner that additional services should be available." The Council is further of opinion that any other persons, while employed in the giving of domiciliary attendance (*e.g.* nurses, midwives, health visitors), should be under the supervision of the general practitioner connected with the case.

10. The Council is of opinion that domiciliary services should only be provided by the State, in whole or in part, for those who are considered, after due enquiry, to be unable to provide the same for themselves.

B. The Relation of Curative and Preventive Medicine.

(Question 4.)

11. The Report states that "preventive and curative medicine cannot be separated on any sound principle, and in any scheme of medical services must be brought together in close co-operation. They must be both brought within the sphere of the general practitioner."

12. The Representative Body has expressed the opinion that "in order to attain the objects of an ideal system of medical and allied services, it is necessary that the prevention of the occurrence of disease, as well as the provision for its treatment, should be based on the domiciliary medical service, and that general practitioners should be actively engaged in the practice of both." The Council is further of opinion that this should apply not only in the sphere of domiciliary service but as far as possible in the sphere of all additional services.

C. Primary Health Centres.

(Questions 5-9.)

13. The Report proposes the establishment of Primary Health Centres administered by or under the auspices of the Local Health Authority, and states that "in the Primary Health Centres there would be gathered together the health services and activities of the districts they served; the distinguishing features of those centres would be that they would be staffed by general practitioners; there would be wards of varying sizes for varying purposes, including provision for midwifery. The Primary Centre would provide the patient (on terms) with food, nursing, and all the equipment of efficient treatment but not with medical attendance, which would be paid for either by the patient, or through some method of insurance, or by the Health Authority." It is understood that the staffing by general practitioners means that it shall be open to any general practitioner of the district to treat any of his patients therein, under varying conditions of service.

14. The Representative Body has expressed the opinion "that in any scheme of medical reconstruction arrangements should be made for auxiliary hospitals in which general practitioners could treat their own patients," and has accepted the view "that the establishment of Primary Health Centres is the pivotal idea of the changes recommended in the Report."

15. The Report of the Welsh Consultative Council appears to suggest the establishment of fully-equipped out-patient departments at Primary Health Centres, but the functions of these departments are not strictly defined.

16. The Council is of opinion that the establishment of out-patient departments for purposes of general treatment would be entirely unnecessary and undesirable.

Common Surgeries.

(Questions 10 and 11.)

17. The Report agrees that the custom whereby each general practitioner has his consulting rooms at his own house, should under ordinary circumstances continue, but suggests that in certain congested areas where it is "impossible for a doctor to provide adequate accommodation at his own expense, it should be possible, if the public interest demands it, for the Health Authority to provide such accommodation at the Primary Health Centres or elsewhere on such terms as are reasonable and after previous consultation with a Local Medical Advisory Council. Where local conditions and medical opinion favoured the plan collective surgeries might with advantage be tried."

18. The Council and the Representative Body have expressed the opinion that Common Surgeries for general practitioners under the ægis of the State should not be approved.

D. Communal Services

(Questions 12 and 13.)

19. The Report states that "there would be accommodation for communal services such as those for pre-natal care, child welfare, medical inspection and treatment of school children, physical culture, examination of suspected cases of tuberculosis and occupational diseases, etc.; these services should, where possible, be aggregated at the Primary Centre; a dental clinic would be an important feature."

20. The Council is of opinion that for the correlation of treatment, for the convenience of the public, general practitioners and consultants, and for economy in administration, it is desirable that such communal services should be arranged at common centres; that if treatment of a non-specialist character at such a clinic is provided by a public authority, it should be carried out in all cases by, or under arrangements approved by, practitioners who are attending the patients or their families at their own homes, the ordinary treatment of tuberculosis, the ordinary work of a maternity and child welfare clinic, and the treatment of minor ailments at a school

clinic, being always regarded as being of a non-specialist character; and that in course of time these as well as other communal services (e.g., adenoids, refractions, venereal diseases) should be handed over to the general practitioner.

E. Secondary Health Centres.

(Questions 14 and 15.)

21. The Report states that "Secondary Health Centres would be mainly of a consultative type, receiving cases referred to them by the Primary Centres, either on account of difficulties of diagnosis or because a highly specialised equipment was needed"; that "cases referred for consultation or treatment would attend at Out-Patient Clinics or would occupy In-Patient Beds; the medical staff of the Secondary Centre being responsible for those cases while at the Centre, but every facility being afforded for general practitioners to keep in touch with their patients"; that "consultants would be appointed for these services, paid on a time basis, with extra fees for special visits; general practitioners should be eligible for these posts," certain tests of eligibility being taken into consideration. The members of the staff of the Secondary Centre would attend the Primary Centre for purpose of consultation at fixed intervals, and in urgent circumstances on special summons. The Report suggests that they should be appointed by a Committee of Selection on which the profession would have a majority of members, the Committee being composed of representatives of (a) the Hospitals; (b) the Health Authority; (c) the University; and (d) the local doctors. General practitioners would be eligible for election to the staff.

22. As part-time officers paid by the Health Authority (probably on a time basis), these consultants would be liable to be called into consultation on the case of any member of the community, whatever his status, who, being a patient in the Primary Centre, was willing to accept them as consultants, and to be seen by them at the time of their regular visits to the Centre. In this way their position would differ from that of the general practitioner attending the patient, as it is contemplated that the fees for attendance on patients other than those attended on some form of insurance or for State payment, shall be a matter of arrangement between the patient and the general practitioner.

23. The Council is of opinion that hospitals for cases of a special character should be established in larger areas which should be linked up with the Primary Hospitals, and that this provision would largely be made by utilising the present voluntary hospitals and poor-law infirmaries, though some additional provision might be required. The Representative Body has expressed the opinion that "the clinical medical staffs should be remunerated on a time basis or on a payment by attendance basis; that a medical committee should play an important part in their selection; and that in every case general practitioners, if possessed of the necessary special qualifications, should be eligible in the same way as consultants or specialists."

F. Practitioners and Administration.

(Question 16.)

24. Under the heading "Administration," the Report deals very tentatively with the composition of the Health Authority and the relation of the profession thereto. Upon the difficult question of the relation of the medical practitioner, as clinician, to the medical administrators it says very little, and that little is by no means clear. This, however, is a matter of immediate practical importance. The Report says that "the present trend of the public health service towards the inclusion of certain special branches of curative work is tending to deprive both the medical student and the practitioner of the experience they need," and this transference of departments of clinical work from private practitioners to whole-time salaried officers under the Medical Officers of Health is still going on. It is an urgent matter to agree on the respective spheres of the administrative officer and the private practitioner, general or consultant.

25. Within any given hospital or clinic there are matters of what may be called internal medical administration, involving such things as the relationship to one another of the practitioners attending the hospital or clinic, the number of beds or cases allotted to each of them, the time the beds are occupied, and possibly some measure of control over the methods of treatment adopted. Such matters may, for each institution or clinic, be in the hands of the ordinary clinical staff, one of them perhaps being in the position of "director" within these limits. The general provision and organisation

of the health services of an area, however, involving the relation of parts to the whole, and of every part and the whole to the Local Health Authority, must be in the hands of an Administrative Medical Officer and his subordinate officers. It is the respective spheres of such administrative medical officers and of the private practitioner that it is so important to determine.

26. The Council is of opinion that, while preventive work must be participated in by both clinicians and administrators in the fullest co-operation, it is, generally speaking, desirable:—

(a) That purely administrative work should be kept distinct from clinical attendance and should be in the hands of whole-time salaried medical officers;

(b) That the giving of advice and treatment to individuals should not be in the hands of such administrative officers, and that (unless in a few exceptional cases) such advice and treatment should be given by part-time medical practitioners;

(c) that the work of medical inspection (apart from advice and treatment) should according to circumstances, be undertaken either by administrative medical officers or by part-time practitioners.

G. Composition and Powers of the Local Health Authority.

(Questions 20 and 21.)

27. The Report states that "as regards the nature of the new Health Authority there are some who favour a Statutory Committee of an existing Local Health Authority, whereas there are others who favour the establishment of an *ad hoc* independent body for the purpose of administering health services alone: the question which of these courses is preferable is one upon which we would rather defer any final expression of opinion." No doubt this is not wholly, or even primarily, a professional question, but it is important to gather the opinion of the profession with regard to it. The Report and the Council and the Representative Body are, however, in agreement as to certain essential points, whatever the nature of the Local Health Authority may be.

28. The Council is of opinion that since a full medical and health provision for any area must be associated with institutions or machinery situated in a town of some considerable size, the most convenient area for health administration would be such a town together with so much of the surrounding district as can be properly and effectively associated with it, regardless of the present local government divisions of counties, county boroughs, municipal boroughs and urban districts; but that whether or no such complete rearrangement of area be regarded as possible, either for general local government purposes or for health purposes only, it is essential that all matters of health administration should stand referred preferably to a Local Health Council, or failing that to a Statutory Health Committee of the Local Government Authority.

29. The Representative Body and Council have expressed the opinion that on such Local Health Council or Statutory Health Committee there should be adequate representation of the medical profession of the area and of other persons or bodies engaged in public health work in the area; that for each area there should be established a Statutory Medical Committee to be directly elected by the medical practitioners resident in the area; that the duties of such Medical Committee should be to advise the Local Health Authority on all medical matters and to appoint the medical representatives on the Local Health Authority; that the administrative expenses of such Medical Committee should be a charge on the public funds; and that such Medical Committee should have the right, whenever it thought desirable, to present its views not only to the Local Health Authority but also to the Ministry of Health and to the public.

30. Questions as to all these points are set forth in Appendix IV.

MINISTRY OF HEALTH (MISCELLANEOUS PROVISIONS) BILL —MUNICIPAL HOSPITALS.

31. The Council desires to call attention to Clause 11 of the Ministry of Health (Miscellaneous Provisions) Bill, introduced into the House of Commons on August 16th last. This clause gives to the Councils of Counties and County Boroughs power (already possessed by urban and rural sanitary authorities under the 1875 Public Health Act, but, with one or two exceptions, not exercised by them) to supply and maintain hospitals (including outpatient departments) of a general or

special character; to contribute on terms and conditions to be approved by the Minister of Health to any voluntary hospital or similar institution in their area; and to maintain any poor-law hospital or infirmary in their area.

32. The Council is of opinion, and is making representations accordingly, that there should be such amendments made to the Bill, and to the 1875 Public Health Act, as will require all local authorities to obtain the sanction of the Ministry of Health to its proposals before exercising any of its powers thereunder. Before such powers are conferred at all it is essential that the conditions on which patients can be received into such aided or maintained hospitals and the terms and conditions of the appointment of the staffs of such hospitals should be made the subject of consultation with the profession. The Report of the Medical Consultative Council points out that "many hospital schemes are likely to be defective because their promoters fail to realise that a modern hospital should be part of a more comprehensive organisation."

APPENDIX IV.

QUESTIONS TO DIVISIONS ON THE REPORT OF THE CONSULTATIVE COUNCIL ON MEDICAL AND ALLIED SERVICES.

Domiciliary Attendance.

(Paras. 5-10.)

(1) Should the State assume responsibility for seeing that for every household in the land a family doctor is available?

(2) Should State provision of a domiciliary service on a free or contributory basis be limited to those who are considered to be unable to provide such service for themselves?

(3) In any further State provision of a domiciliary service upon a contributory basis, should the method of contributing be by an insurance scheme or otherwise? If otherwise, in what way?

The Relation of Curative and Preventive Medicine.

(Paras. 11 and 12.)

(4) Should practitioners associated with the State provision of a domiciliary service be required to undertake duties in relation to (a) personal and domestic, and (b) industrial hygiene and other spheres of preventive medicine?

Primary Health Centres.

(Paras. 13-16.)

(5) Are Primary Health Centres as described in the Report, or Centres similar thereto, an essential part of an efficient general practitioner service?

(6) Should all the general practitioners practising in the area have the right to use them?

(7) What variation, if any, as between the metropolitan, urban and rural areas should be adopted in their organisation?

(8) Under what conditions ought Primary Centres to be available for the different classes of the population?

(9) Is it desirable that out-patient departments for the purposes of general treatment should be established in connection with such centres?

Common Surgeries.

(Paras. 17 and 18.)

(10) Are Common Surgeries for general practitioners under the aegis of the State or a Local Authority desirable, and if so, under what conditions?

(11) Are Common Surgeries established and controlled by general practitioners themselves desirable, and if so, under what conditions?

Communal Services.

(Paras. 19 and 20.)

(12) Should the communal services (e.g. school clinics, tuberculosis clinics, venereal disease clinics, infant welfare clinics) be aggregated, whenever possible, at the Primary Health Centre?

(13) Is it essential that the work of these services, when it is not definitely of a specialist character, should be in the hands of the general practitioners of the locality? If so, in what way should the work be distributed and organised?

Secondary Health Centres.

(Paras. 21-23.)

(14) What is the most appropriate method of selecting the staff of a Secondary Health Centre or Hospital?

(15) Under what conditions should consultant and specialist facilities be made available under Health Authorities to the different classes of the population?

Practitioners and Administration.

(Paras. 24-26.)

(16) Have you any practical suggestions to make with regard to the line of differentiation of the administrative officer from the clinician?

Composition and Powers of the Local Health Authority.

(Paras. 27-29.)

(17) Do you regard the points set out as adequate representation of the profession on the Local Health Authority, and the establishment of a Statutory Medical Committee in each area, of the type and with the powers indicated, as absolutely essential?

(18) What do you regard as the most desirable form of constitution for the Local Health Authority, having regard to practical considerations, both of health administration and of local government?

Consultant and Specialist Services.

(19) Are there any objections to the scheme proposed with regard to consultant and specialist services from the point of view of:—

- (a) the General Public,
- (b) the General Practitioner,
- (c) the Consultant?

APPENDIX. V.

SUMMARY OF THE REPLIES OF DIVISIONS RECEIVED TO THE QUESTIONS UPON THE REPORT OF THE COUNCIL RESPECTING THE REPORTS OF THE CONSULTATIVE COUNCILS ON MEDICAL AND ALLIED SERVICES.

A.—ANALYSIS OF QUESTIONS.

DOMICILIARY ATTENDANCE.

(Paras. 5—10).

Question 1.—Should the State assume responsibility for seeing that for every household in the land a family doctor is available?

76 answer No. 41 answer Yes.

Question 2.—Should State provision of a domiciliary service on a free or contributory basis be limited to those who are considered to be unable to provide such services for themselves.

114 answer Yes. 6 answer No. 7 do not answer.

Question 3.—In any further State provision of a domiciliary service upon a contributory basis, should the method of contributing be by an insurance scheme or otherwise? If otherwise, in what way?

96 answer—By an insurance scheme. 7 answer No. 24 either do not answer the question or give answers which are neither Yes or No.

Question 4.—Should practitioners associated with the State provision of a domiciliary service be required to undertake duties in relation to (A) personal and domestic, and (B) industrial hygiene and other spheres of preventive medicine?

89 answer Yes. 14 answer No to both sections (A) and (B). 10 answer Yes to section (A) and No to section (B). 1 answers No to (A) and Yes to (B). 5 give other answers. 3 do not answer at all.

Question 5.—Are Primary Health Centres as described in the Report, or Centres similar thereto, an essential part of an efficient general practitioner service?

106 answer Yes. 13 answer No. 8 do not answer the question at all.

Question 6.—Should all the general practitioners practising in the area have the right to use them?

115 answer Yes. 1 answers No. 2 answer—Not applicable. 9 do not answer at all.

Question 7.—What variation, if any, as between the Metropolitan, Urban and Rural areas should be adopted in their organisation?

106 either do not answer the question or intimate they have no suggestion to submit; a few state they do not understand the question. 24 make suggestions.

Question 8.—Under what conditions ought Primary Centres to be available for the different classes of the population?

All but 16 answer this question. The general opinion is that Primary Centres ought to be available for all sections of the population; free to the necessitous and by a graduated system of payment to others; whilst all patients should be admitted only on the recommendation of a general practitioner, except in emergencies.

Question 9.—Is it desirable that out-patient departments for the purpose of general treatment should be established in connection with such centres?

101 answer No. 13 do not answer at all. 12 answer Yes.

Question 10.—Are Common Surgeries for general practitioners under the aegis of the State or a Local Authority desirable, and, if so, under what conditions?

108 answer No. 7 answer Yes. 11 do not answer at all.

Question 11.—Are Common Surgeries established and controlled by general practitioners themselves desirable, and, if so, under what conditions?

52 answer No. 9 do not answer at all. The remainder suggest either that it might be left to local option if controlled by general practitioners or that system might be established in congested areas.

Question 12.—Should the communal services (e.g., school clinics, tuberculosis clinics, venereal disease clinics, infant welfare clinics) be aggregated, whenever possible, at the Primary Health Centre?

108 answer Yes. 6 answer No. 9 do not answer at all.

Question 13.—Is it essential that the work of these services, when it is not definitely of a specialist character, should be in the hands of the general practitioners of the locality? If so in what way should the work be distributed and organised?

2 answer No. 8 do not answer at all. 116 answer Yes to first part of this question and make various suggestions.

Question 14. What is the most appropriate method of selecting the staff of a Secondary Health Centre or Hospital?

23 do not answer the question. 104 do answer it, of which 58 suggest the method mentioned in the Report of the Consultative Council. 9 suggest the method mentioned in the following paragraph 23 of Association's Report:—

23. The Council is of opinion that hospitals for cases of a special character should be established in larger areas which should be linked up with the Primary Hospitals, and that this provision would largely be made by utilising the present voluntary hospitals and poor law infirmaries, though some additional provision might be required. The Representative Body has expressed the opinion that "the clinical medical staffs should be remunerated on a time basis or on a payment by attendance basis; that a medical committee should play an important part in their selection; and that in every case general practitioners, if possessed of the necessary qualifications, should be eligible in the same way as consultants or specialists."

34 mention other ways.

Question 15.—Under what conditions should consultant and specialist facilities be made available under Health Authorities to the different classes of the population?

The consensus of opinion seems to be that specialist facilities should be available only on recommendation of general practitioners and that patients should pay according to their means, only the necessitous poor being paid for by the State or Local Authority. Some divisions consider that these facilities should be made available only to those who are unable to provide same for themselves.

Question 16.—Have you any practical suggestions to make with regard to the line of differentiation of the administrative officer from the clinician.

36 either do not answer or state that they have no suggestions to make. 52 intimate that they accept the relevant suggestions on the Association's report. 36 other answers do not give any practical suggestions beyond stating that the administrative and clinical work should be separated, and that the administrative officer should have nothing to do with clinical work.

Question 17.—Do you regard the points set out as to adequate representation of the profession on the Local Health Authority, and the establishment of a Statutory Medical Committee in each area, of the type and with the powers indicated, as absolutely essential?

11 do not answer at all. 105 answer Yes. 11 give other answers.

Question 18.—What do you regard as the most desirable form of constitution for the Local Health Authority, having regard to practical considerations, both of health administration and of local government?

32 do not answer the question. 21 state they agree with suggestions of the Association. 32 suggest an independent ad hoc body. 12 suggest a committee of existing Health Authority. 5 state they agree with the proposals in paragraph 98 of the Consultative Council's Report. 28 give other answers.

Question 19.—Are there any objections to the scheme proposed with regard to consultant and specialist services from the point of view of:—(A) the General Public; (B) the General Practitioner; (C) the Consultant?

24 give answers covering all 3 sub-sections. The chief objection mentioned is that of expense.

SUB-SECTION (A).

24 answer generally as stated above. 49 answer No. 36 do not answer. 10 answer Yes, the objection being chiefly expense.

SUB-SECTION (B).

24 answer generally as mentioned above. 43 answer No. 40 do not answer. 12 answer Yes, and state their objections, which may be summarised as fear of bureaucratic control and loss of individuality.

SUB-SECTION (C).

Many useful and detailed suggestions are made by certain Divisions. These are receiving the attention of the Committee.

APPENDIX VI.

COMMUNICATION AND MEMORANDUM RECEIVED FROM THE FEDERATION OF MEDICAL AND ALLIED SOCIETIES.

5, Vere Street,
Cavendish Square,
London, W.1.
January 19th, 1921.

The Medical Secretary,
British Medical Association.

Dear Sir,

We desire to draw the attention of your Council to the crisis that has arisen in regard to the organisation of the medical profession and enclose herewith copies of an explanatory Memorandum. It will be seen that Dr. Addison has made clear that he cannot receive any existing medical body as representing the views of the profession, and that he calls upon the various organisations to agree together.

The reasons preventing co-operation between certain important medical bodies appear to be based upon misunderstanding rather than irreconcilable divergence of views, and it is thought that a satisfactory solution to present difficulties would be found in open discussion.

On March 23rd, 1920, we invited the British Medical Association to reopen the Conferences it arranged in 1919 between five medical bodies, three of whom subsequently found the means of co-operation in the Federation. This invitation, we regret to say, was declined.

Before again approaching the Minister, we are anxious to find the greatest common measure of agreement possible, and therefore invite your Council to agree to nominate three representatives to attend a Private Conference on Tuesday, February 1st, at 5 p.m., at the Medical Society of London, 11, Chandos Street, W.1. Sir Humphry Davy Rolleston, K.C.B., M.D. (who is not connected with the Federation) has kindly agreed to act as Chairman.

The only matter the Conference will be asked to consider is the reference Dr. Addison has given the profession, namely, to agree together.

In addition to the Royal Colleges, whose assistance is sought, this invitation is being sent to the following bodies, whose co-operation with the societies forming this Federation would make collective representation possible:—

The British Medical Association; The Society of Medical Officers of Health; The Medico-Political Union; The National Medical Union and The Edinburgh Medical Guild. Three representatives of the Federation will also be nominated.

We are,

Yours very truly,

MALCOLM MORRIS (Chairman Executive Council).
ARTHUR LATHAM (Vice-Chairman Executive Council).
THOMAS HORDER (Hon. Treasurer).
WILLIAM PASTEUR } Royal Society of Medicine.
H. FARQUHAR BRIZZARD }
RONALD ROSS (British Science Guild).
R. H. COLE (Medico-Psychological Assoc. of Gt. Brit. & Ireland).
JOHN ROSE BRADFORD } London & Counties Med. Protec.
SIDNEY SPORTS } Sec.).
JANE WALKER (Medical Women's Federation).
H. J. CARDAL (Assoc. of Panel Committees).
C. F. RILEY (British Dental Assoc.).
PHILIP ROWSELL (Pharmaceutical Soc. of Gt. Britain).
COMYNS BERKELEY (College of Nursing).
N. HOWARD MUMFERY (Gen. Sec.).
Members of Executive Council.

MEMORANDUM

(CONTINUING)

THE URGENT NEED OF REPRESENTATIVE MEDICAL OPINION.

The collected and considered views of the medical profession are most urgently needed at the present time in connection with the reorganisation of the Health services, but are not available.

Of the numerous medical bodies, some aspire to represent the medical profession as a whole, and one—the British Medical Association—has claimed to do so. Neither it nor any other organisation of doctors is however recognised by the profession and by the Minister of

Health as individually representative of all sections and interests in medicine. This has been made sufficiently clear in Dr. Addison's recent public statements.

THE ATTITUDE OF THE MINISTER OF HEALTH.

On November 1st, 1920, in reply to a deputation of the British Medical Association, which asked that the medical profession might be consulted, Dr. Addison said:—

"He agreed as to the reasonableness of consultation, if the machinery for the purpose were available, but he would not consult a number of different bodies each claiming to represent the profession. If you want us to consult you, get busy and set up some machinery whereby you can readily be consulted." He added: "There is a local branch of the Association in each area but there are other local medical associations and societies as well."

On December 9th, 1920, Dr. Addison made the following statement to a deputation of the Medico-Political Union:—

"The voice of a united profession, speaking not of its own interests primarily but of the best way in which its services can be arranged for the public benefit, is most urgently required but has not yet been obtained. There is no lack of those who say they represent the profession as a whole, but there is no one body which even claims to represent all interested organisations, although some aspire to. It cannot be expected that a Minister should reconcile these interests or continue to consult a number of bodies. If you (Doctors) wish to procure attention for your views, you must agree together first. In no other way is it possible for your views to be represented in the Councils of those concerned with the reconstruction of the Health services."

THE PRESENT IMPASSE

This failure to find adequate collective expression cannot continue without grave detriment to both public and professional interests, and it appears urgently necessary to find the means of co-operation likely to qualify the profession to take its place on the councils of those concerned with the reorganisation of the Health services. Such co-operation need in no way affect direct Government consultation with certain bodies regarding principles or sectional interests.

REQUIREMENTS OF A REPRESENTATIVE BODY.

1. It should be able to represent the collective views of all sections of medical practice.

This cannot be effected by sounding every individual medical practitioner, except by referendum in the case of some clear-cut issue.

It can only be effected by sounding the collective opinion of sections of the profession.

2. It should leave to the existing bodies their respective and legitimate functions.

Therefore, it cannot concern itself with the domestic interests of the members of such bodies, or any matters not public concern.

3. It must be entirely independent, and free of bias towards either Government policy or sectional medical interests.

This can only be accomplished by a federation of bodies in which no one of them is dominant and whose office is distinct from those of the bodies co-operating.

4. It should be recognised by the public and the Government as existing to promote the best interests of the community rather than of the doctor.

5. It should link up with the medical profession those allied professions and occupations whose services are of an ancillary nature.

WHY NO EXISTING MEDICAL BODY IS SUITABLE.

No medical association or society includes the whole profession, the largest claiming but 52 per cent. of those on the register at home and abroad.

No one body is recognised by even a majority of the others as representing all sections.

The various separate bodies are unlikely ever to agree to sink their individuality in one of their number or subordinate their own, to its policy.

All existing medical bodies are viewed by the public as concerned with the advancement of professional interests alone and consequently as unable to express disinterested views.

THE MEANS AVAILABLE.

The present difficulty was foreseen in October, 1918, when a number of medical societies united to set up machinery such as now seems to be required. For two years this work has continued, and although The Federation of Medical and Allied Societies (which has been the outcome) cannot yet claim to provide the means of collective expression for all sections of the profession and its ancillary services, it does provide these means for 45 distinct societies, representing over 18,000 medical men and women and over 90,000 of those in the dental, pharmaceutical nursing and kindred callings.

As a partnership of free societies (rather than an addition to their number), the Federation has already accomplished much in uniting the medical profession. And, it seeks no leadership or control and confines itself to the public aspect of Health matters, it should tend to the increased prosperity of the various existing bodies who cannot but gain by mutual co-operation.

THE NECESSITY OF A CONFERENCE.

The reasons at present preventing co-operation between certain of the representative organisations, to whom this invitation has been issued, appear so incompatible with their avowed aims that the Council of the Federation feels that the difficulties would dissolve in open discussion. With this object a letter was addressed to the Council of the British Medical Association on March 23rd, 1920, asking it to call a conference of bodies to discuss co-operation. As this was declined my Executive Council considers that, before the Minister is again approached, an endeavour should be made to find the greatest possible common measure of agreement. In this endeavour the assistance of the Royal Colleges is particularly sought.

N. HOWARD MUMMERY, Lt.-Col.,

General Secretary,

The Federation of Medical and Allied Societies."

APPENDIX VII.

THE MEANS OF OBTAINING THE COLLECTIVE OPINION OF THE MEDICAL PROFESSION ON QUESTIONS OF POLICY.

1. The Minister of Health, addressing a deputation from the British Medical Association on November 1st, 1920, complained of the number of bodies that approached him claiming to be representative of the profession, and asked that some one body recognised as representing the whole profession should be provided, so that he could consult it on matters of policy affecting the medical profession. Further, in a letter to the Chairman of Council of the Association, dated November 26th, 1920, the Minister said he was "satisfied that it would be impossible to secure the constitution of a representative body without the good offices of the B.M.A. in bringing them together," and went on to suggest that the Council of the Association "should now initiate action to secure the appointment of a body whose credentials will be incontestable."

2. The Association has accepted the Minister's suggestion, and has invited certain medical bodies to co-operate with it in constituting a body which will satisfy his requirements. The Association desires to state its views as to the qualifications of such a body.

QUALIFICATIONS OF A BODY REPRESENTING THE MEDICAL PROFESSION AS A WHOLE.

3. In the first place the body must represent the views of the medical profession and the medical profession alone. The Minister has asked for such a body. When he wishes for the views of the Dental, Pharmaceutical or Nursing professions, he will naturally call on the organisations which represent those professions. They would not desire to have their views confused with those of the medical profession, and the medical profession would certainly not consider that representations from any body which attempted to fuse the interests and views of widely differing bodies ought to be taken by the Minister as the considered policy of the medical profession.

4. The body must be an immediately and directly responsible body—that is to say it must recognise the authority of its constituents and no other authority. It must be under the constitutional control of the whole of its constituents and without undue bias toward any one section of them. A body which the bulk of the profession felt they had no direct means of controlling would be worse than useless for the purpose of the Minister, and might do great damage to the interests of the profession itself.

5. The body must therefore be really representative. That is to say it must have modern constitutional methods of ascertaining the opinion of its constituents and of securing their acceptance of agreements made on their behalf. The body as a whole, or the constituent parts of the body, must therefore have machinery, both central and local, for the purpose of eliciting opinions on policy.

6. The constituents of the body must be directly and intimately concerned in what is generally known as "medical politics," and they must be trained in expressing opinions on such matters. Bodies exclusively or mainly scientific have no concern with medical politics and have not the machinery for dealing with such matters.

7. The body must not profess to promote the interests of the community rather than those of doctors. Such a body would not be recognised by doctors as the body which primarily represents them and their views. Doctors are citizens as well as doctors, but what the Minister is understood to require is a body which will tell him what doctors *qua* doctors think, whether as to the interests of their own profession or as to general questions of public health.

HOW FAR DOES THE B.M.A. MEET THESE REQUIREMENTS.

8. The British Medical Association acting alone would be justified in claiming that it possesses the qualifications enumerated above. It contains 52 per cent. of the whole profession on the Register, and this percentage applies approximately to every section of the profession. If those who are not practising their profession, and what may be called the "floating medical population" be eliminated, the Association could be shown to include about 60 per cent. of the active members of the profession.

9. It is really representative of its members and has well-tried machinery, both local and central for ascertaining their views. The control of its members over the Association is thoroughly democratic and complete. Its members are trained, both locally and centrally, in dealing with medical politics. It does not profess to represent the views of other professions, but it does claim to know with greater certainty than any other body the opinions of the majority of the medical profession.

10. Moreover, the Association is recognised informally by large numbers of practitioners who do not belong to it as the body which voices the wishes and sentiments of the profession as a whole. It is very frequently consulted by non-members individually in their troubles; also by bodies of non-members, or bodies of local practitioners, some members some not. It is recognised by the public as the body which bears the same relation to doctors generally as, for example, the National Union of Teachers does to elementary teachers, or the Miners' Federation to miners. The Government has frequently made use of it as the body which can more adequately than any other body represent the general profession. To name only the most recent and most conspicuous example—the machinery of the Association, both central and local, was used by the Government for the purpose of providing doctors for the Services with due regard to the interests of the civil population. The Government recognised that there was no other existing body which had the machinery, and there was no question about the Association's ability to deal with and represent the views of practitioners, whether members of the Association or not.

11. The Association does not profess to include every member of the medical profession, and it knows of no organisation of any other calling which can make such a claim. The Association does claim to be by far the largest body of organised medical practitioners with a machinery capable of eliciting, by recognised constitutional methods, the views of the organised profession.

CO-OPERATION OF B.M.A. WITH OTHER ORGANISED MEDICAL BODIES.

12. In order to make itself as useful as possible to all sections of the profession the Association has always tried to work with organised bodies representing distinct

sections of the profession. Representatives of the Society of Medical Officers of Health, the Medical Women's Federation, the Poor Law Medical Officers' Association of England and Wales, the Medico-Psychological Association, the Association of Certifying Factory Surgeons, and other bodies have frequently sat on Committees of the Association. All these Societies have on occasion attended on deputations to Ministers arranged by the Association. Most of them regularly and closely co-operate with the Association in its work for the profession. The three first-named societies have standing representation on some of the most important Committees of the Association.

13. The Insurance Acts Committee of the Association in a very special way represents the interests of the (approximately) 14,000 practitioners engaged in National Health Insurance work. A majority of the Committee consists of members elected directly by the Local Medical and Panel Committees of the country, with no restriction as to whether their nominees are members of the Association or not. The Committee is directly authorised by a representative Conference, acting on behalf of the Local Medical and Panel Committees, to carry out all negotiations with the Ministry of Health on matters affecting practitioners engaged in National Health Insurance work.

14. Though the constitution of the Association and its traditional and regular co-operation with bodies representing special sections of the profession would justify it in claiming the qualifications required by a body representing the profession generally, it has invited these other bodies as independent organisations to join with it in attempting to form the body suggested by the Minister of Health.

15. The Association therefore feels that in accepting Dr. Addison's suggestion, if, as it expects, it secures the co-operation of the medical societies above named, it will be able to offer the Minister a body which (with the exception next to be mentioned) is really representative of all the organised medical profession, both generally and sectionally. The body when formed would, of course, consult with other medical bodies not directly represented on it when such consultation was thought desirable or necessary.

16. The exception referred to is that of the Royal College of Physicians of London and the Royal College of Surgeons of England. The Association recognises that the Councils of these bodies are able to speak for the consultant section of the profession in a way which is not open even to the British Medical Association, which includes a large number of the Fellows of the Colleges. The Association has intimated to the Royal Colleges that their co-operation in the matter now under consideration would be greatly valued and that after the adhesion of the other bodies referred to has been obtained the Royal Colleges will be approached again more formally.

APPENDIX VIII.

REPORT ON THE FUTURE OF POOR LAW INFIRMARIES: WITH RECOMMENDATIONS AS TO THE UTILISATION OF POOR LAW INFIRMARIES FOR CIVIL NEEDS.

GENERAL MANAGEMENT.

1. Whether the body responsible for the Poor Law Infirmaries is to be the Guardians or some other body similar to the Metropolitan Asylums Board or the Municipal Council, it seems to be very important that the local medical profession should be represented on the Committee of Management.

There is no object in aiming at a very high percentage of representation. What is required is that a small number of local medical practitioners who are prepared to give time to the subject should be appointed.

2. A present difficulty with the Poor Law is the strict limitation of the patients in any given Infirmary to those who belong to a given "parish" or Union. This may have to be maintained under a municipal system in London, but it would be greatly to the advantage of the sick poor if some system could be adopted whereby people from other parishes or boroughs could attend any given Infirmary which can present them with special advantages, the cost of maintenance to be recovered from their Poor Law Union or Borough.

3. If "Poor Law" is done away with the Infirmaries will tap a type of patients at present very partially reached, such as those who are not in the strict sense entitled to Poor Law relief or object to be classed legally as paupers; and, far from there being any spare beds, very shortly there will be more applications than accommodation. Even now the amount of spare accommodation has been much exaggerated.

4. The only chance of meeting the needs of accommodation will be to utilise sick wards in the Workhouses to a much greater extent than hitherto for senile and unprogressive cases. Also it is very desirable that certain classes of cases should have accommodation elsewhere than in the best-equipped infirmaries. For example: cases of Tuberculosis might well be dealt with in special infirmaries set aside in various parts of London for such cases; also the infirmaries suitable for acute cases should not receive cases of Measles, Chicken Pox, Whooping Cough, &c., as, with the best efforts, these diseases are apt to spread.

5. It is to be hoped that the system of paying for hospital treatment will be maintained under any new system. Those unable to pay at all receiving benefit gratis (or possibly paid for by some authority, i.e., Guardians), and those able to pay a sum meeting the total cost of maintenance being, if thought desirable, treated as private patients with certain privileges. At the same time such patients should realise that they also are receiving benefit from public funds, as the "cost of maintenance" in no case meets the actual money expended on them.

6. With regard to the method of admission. It is desirable that the normal method of admission to the Infirmary should continue to be as at present, on the recommendation of a general practitioner. Cases of urgent illness and accident should be admitted, as at present, by the Medical Superintendent. It is not desirable to have an ordinary out-patient department attached to an Infirmary and run by the paid resident staff. If in any degree attached to the Infirmary such out-patient departments should be staffed by local practitioners, and the most that is desirable may be that the Medical Superintendent might have administrative control for the sake of unifying all the work.

METHOD OF STAFFING THE INFIRMARY.

7. There seem to be three rival suggestions:—

(a) Present system in large Infirmaries.

The present system which obtains in most large Poor Law Infirmaries provides that the work is done by a whole-time Medical Superintendent and his Assistants, who are all resident on the premises and devote their energy and attention exclusively to their patients.

This system forms an excellent foundation for the further building up of the professional side of the work.

8. This is not the place to enter into the duties and responsibility of the Medical Superintendent, but, for smooth working, the comfort of the patients, the satisfaction of the friends, and general efficiency, the system of making a senior Medical Officer responsible for the superintendence of everything is a sound one.

9. It is desirable that the Medical Superintendent should, in all cases, if possible, take a definite share of the professional work. It is impossible for him to attempt to treat any large proportion of the patients himself, but there should be a certain part, (for example, the "acute surgery" or some branch of medicine, "skin diseases," &c.) which he should take. It will be impossible to ensure the professional proficiency of the men to be chosen as Medical Superintendents unless the post offers to a keen medical man some medical interest. Besides this, in almost every case the Medical Superintendent must be responsible for much of the routine duties of a Medical Registrar.

10. The Assistant Medical Officers should be thoroughly efficient general practitioners; men who have done hospital appointments at the teaching hospitals and are of good professional standing. There is much routine work, but, on the other hand, considerably more professional responsibility than falls to the resident in the Voluntary Hospitals, and the appointments should be very valuable to practitioners who want to have two or three years experience of the kind of work they will have in general practice, before starting on their own account. The value of this work as experience for

general practitioners would be greatly increased if it could be provided that a proportion of these posts was tenable as part-time appointments by local practitioners of similar training, who were prepared to give the necessary regular service.

11. The Assistant Medical Superintendent should be, as far as possible, the complement to the Medical Superintendent. Where the latter is primarily a surgeon the assistant should be a thoroughly efficient junior physician, and where the Medical Superintendent is primarily a physician the Assistant Medical Superintendent should be primarily an operative surgeon.

12. Infirmary Superintendents are now realising that the increasing responsibility of their work and the great expansion of methods of diagnosis and treatment make it most desirable that consulting advice should be provided at the Infirmaries. For this a certain number of specialists should be attached to the Infirmaries and attend when necessary.

13. If these specialists belong to a teaching hospital and the teaching hospital can be brought into co-operation with the Infirmary, that will give great advantages, both for the teaching of students and because patients requiring specialised treatment can be transferred from the Infirmary to the Voluntary Hospital. Other Infirmaries may advantageously be used for Post-Graduate study.

(b) System of Voluntary Hospitals.

14. In mentioning this a distinction must be made between the teaching hospitals, where all the staff are by way of being specialists, and the non-teaching hospitals, especially in the Provinces, where the Medical Staff are in the main general practitioners.

15. If the staffing of Voluntary Hospitals by consultants and specialists were applied to Poor Law Infirmaries, the type of practitioners who would be attracted to the work would alter materially. The Medical Superintendent's duties would become mainly administrative as the consulting staff would undertake the clinical duties usually performed by him; the lessened responsibility would reduce the attractiveness of the Medical Superintendent's office and that of the offices of whole-time assistant medical officers who would be replaced by the junior resident staff usual in Voluntary Hospitals. These consequences would materially affect the opportunity for participation in the work by private practitioners employed on a part-time basis. It will probably be thought better to have a carefully selected staff of assistant medical officers, whether these be whole-time or part-time, who would be able to call in, through the Medical Superintendent, expert advice which the patient's condition calls for, rather than to graft the voluntary system of staffing on to the Poor Law Infirmaries.

(c) System whereby whole-time Staff is replaced by General Practitioners.

16. The third system which has been suggested is that the general practitioners of the area should replace in so far as it is possible the assistant whole-time resident staff.

17. There should be no great difficulty in securing that a private practitioner in the district who has specialised training should have the opportunity of coming on to the hospital staff as a consultant, or as an assistant medical officer as suggested at the end of para. 10. It appears, however, impossible to staff a large Infirmary with an indefinite number of general practitioners whose right to come in would be claimed on the ground that the cases were sent in by them and therefore should continue under their treatment inside. It is contended that private patients who are admitted to a Poor Law Infirmary should be allowed to avail themselves of the services of their own medical attendants, but it is considered impracticable to extend this principle to ordinary Poor Law patients.

RECOMMENDATIONS.

Admission of Private Patients employing their own Doctor.

1. That in those Poor Law Infirmaries where there is spare accommodation and when the needs of the Poor Law patients have been met, it would be desirable that certain beds should be set aside for private patients paying a fee to be settled by the Guardians; that where a general practitioner wishes to continue to treat therein patients

of his own, he should be allowed to do so under the general administrative supervision of the Medical Superintendent, and that any of these patients should be allowed to call in a consultant from outside, the patient bearing the cost thereof.

Inclusive Charge for Maintenance: Doctor paid by private arrangement.

2. That for "paying" patients admitted to Infirmaries there should be an inclusive charge to cover the cost of medical supervision, maintenance, nursing, food and medicines, within the ordinary tariff and pharmacopœia of the Infirmary, the patient paying his medical attendant independently.

Extra comforts to be available as "extras."

3. That any extra nursing and any food or medicine ordered over and above those allowed under the ordinary tariff and pharmacopœia of the Infirmaries should be charged as extras to the patient.

Administrative Supervision by Medical Superintendent.

4. That all medical attendance by private practitioners on "paying" patients in Infirmaries should be under the administrative supervision of the Medical Superintendent of the Infirmary.

Utilisation of Infirmaries for Medical Education.

5. That Infirmaries, so far as practicable, should be utilised for medical education.

Tendency towards "Primary Health Centre" type.

6. That in any hospital maintained by a local authority (including the Board of Guardians) for general cases, provision should be made for wards for the reception on the lines of the suggested primary health centre as outlined in the Consultative Council's report of private patients admitted on the recommendation of their own practitioner who should be able to attend these patients in such wards.

Representation of profession on Management Committee.

7. That Municipal Hospitals should be controlled by an *ad hoc* Committee on which there should be a small but definite representation of the medical profession.

Hospital benefits not to be confined to particular Parish or Union.

8. It is desirable in the interests of the patients that the Medical Superintendent should have power in special cases (including cases of urgency) to admit or retain patients from other parishes, the Guardians being empowered to recover the cost of maintenance thereof from the parish or borough in which the patient resides.

Use of Sick Wards in Workhouses for chronic cases.

9. That to meet the needs of accommodation, the sick wards in the Workhouses should be utilised to a much greater extent than hitherto for senile and chronic cases, and should be under the control of the Medical Superintendent of the Infirmary.

Exclusion of certain classes of cases.

10. That certain classes of cases, e.g., tuberculosis and certain infectious fevers not already provided for, should not be accommodated in general infirmaries, but in special hospitals arranged for this purpose.

Method of Admission to Hospital.

11. That the normal method of admission to an Infirmary should be on the recommendation of a general practitioner.

Eligibility of local profession for staff.

12. That District Medical Officers be selected from the private practitioners of the neighbourhood.

13. That, except for the treatment of private patients, the normal medical staff of an Infirmary should be a combination of the whole-time resident staff or a part-time selected staff with part-time specialists, the last being called in by the Medical Superintendent as and when necessary.

British Medical Association.

CURRENT NOTES.

Paying Patients in Poor Law Infirmaries.

A DEPUTATION from the British Medical Association attended at the Ministry of Health on April 26th to discuss with the Minister the conditions under which paying patients might be admitted to Poor Law infirmaries. Sir Alfred Mond was accompanied by the Earl of Onslow (Parliamentary Secretary) and by permanent officials of the Ministry. The deputation was headed by the Right Hon. Sir Clifford Allbutt (President of the Association), who made a graceful reference to Sir Alfred Mond's new appointment, and by Dr. R. A. Bolam (Chairman of Council), who briefly outlined the position and influence of the Association. Both Sir Clifford Allbutt and Dr. Bolam disclaimed, on behalf of the Association, any connexion with recent irresponsible criticism of the Ministry. Mr. Bishop Harman (Chairman of Hospitals Committee) then proceeded to lay before the Minister the suggestions of the Association with regard to the utilization of Poor Law infirmaries for civil needs. He emphasized three points which it was desirable to secure: (1) That the local medical profession of the districts concerned should be consulted with regard to any schemes which it was proposed to bring into operation; (2) that patients should only be accepted, as a general rule, on the recommendation of a private practitioner; and (3) that private practitioners should have the right of entry, so that patients might continue to be attended within the institution by the practitioner of their choice. Sir Alfred Mond made a brief but sympathetic reply. He said that he was well aware of the position and influence of the British Medical Association. To the points brought forward by Mr. Bishop Harman he could not give a very definite answer at that juncture. He saw certain advantages in the linking up of the private practitioner in the manner proposed; he also saw possible difficulties. He had not yet found time to study the whole problem, but he expressed himself as greatly obliged to the Association for bringing forward the proposals, which would have his careful consideration, and he invited further conferences on this and other difficulties concerning work in which the Ministry and the Association had a common interest. A full report of the proceedings will appear in the next issue of the SUPPLEMENT.

Health Certificates for Emigrants.

In a Current Note published in December last, attention was called to the serious inconvenience, or possible hardship, which may be inflicted on emigrants who have received from private practitioners certificates of good health which are not accepted by the medical officer at the port of embarkation or, as is more likely, at the port of disembarkation. The secretary of the Oversea Settlement Office has called the attention of the Association to two cases which illustrate what may happen to emigrants who are not physically sound but who have managed by some means or other to pass through the meshes of the net which is designed to catch them. In his letter the secretary says: "It is not clear how far the disabilities in question in these cases could have been detected in the first instance, but it is felt that such instances emphasize the need for caution on the part of medical practitioners who are asked to issue health certificates to intending settlers." In one case the emigrant suffered from epilepsy and in the other from arthritis in the feet. The epileptic, after being discharged from employment on several occasions on account of his fits, was eventually sent back to England. The man with arthritis is in hospital, and the Oversea Settlement Department has been asked to pay the cost of his passage back to England. It is quite possible that in both these cases there was nothing which the medical examiners could detect at the time of the examination. The difficulty might, however, be got over by pointing out to the intending emigrant what will almost certainly happen to him if any condition from which he has suffered, but which he has not disclosed to his doctor, incapacitates him after his arrival in the country to which he is going.

Anaesthetists' Fees in Insurance Practice.

A Current Note which appeared under this heading in the SUPPLEMENT of April 16th contained the following statement in connexion with the circular of the Ministry of Health, printed on page 99 of the same Supplement:

With the decisions which are now set out in the circular letter referred to above the Insurance Acts Committee is in entire agreement.

This statement requires modification, in view of the inclusion in the circular of the following decision (2) (d):

"In the comparatively rare cases where teeth are extracted by an insurance practitioner as part of his agreement—for example, in rural areas where this service is customarily undertaken by doctors—a fee would be chargeable against the Practitioners' Fund."

The attention of the Ministry has been drawn to the fact that the point was one which had never been referred to the Conference of Panel Committees, and that consequently the Insurance Acts Committee was not in a position to signify its assent to the decision on behalf of insurance practitioners.

Annual Meeting at Newcastle: Ophthalmological Section.

It has now been arranged that the Ophthalmological Section at the forthcoming Annual Meeting of the British Medical Association at Newcastle-upon-Tyne will meet on Wednesday, July 20th, and Thursday, July 21st, instead of, as was formerly announced, on the Thursday and Friday.

Association Notices.**NOTICES OF MOTION BY DIVISIONS FOR THE ANNUAL REPRESENTATIVE MEETING, NEWCASTLE, 1921.****By NEW SOUTH WALES DIVISION-BRANCH:**

That the annual subscription of members in Australia be £1 10s. instead of £2 2s. as at present; and that By-law 11 (1) (b) be amended accordingly.

By GATESHEAD DIVISION:

That the names of candidates for membership of the British Medical Association should be brought before the Division in which they reside.

That, in order to stimulate the interest of senior students of medicine in the work of the British Medical Association, and so tend to secure their adherence at the outset of their careers as practitioners, the British Medical Association institute a *student class* of members at a reduced fee, with the privilege of attending scientific meetings and receiving a free copy of the JOURNAL weekly.

By PORTSMOUTH DIVISION:

That the Representative Body is of opinion that medical men practising as whole-time officials of public authorities should be precluded from practice for private reward in the same district (i) while holding their appointments; and (ii) for a period of five years subsequently, except with the consent of the local medical profession.

That the Representative Body express the opinion that the collective opinion of the medical profession can be adequately and truly expressed to the Minister of Health only through a body elected directly by the profession for that purpose, such body to have the power, if thought advisable, to co-opt for any special purpose representatives of the medical profession not exceeding one third of the total number of the committee.

Rider: That this election should be organized and conducted by the British Medical Association.

By GUILDFORD DIVISION:

That the Representative Body is of the opinion that the present method of election of the members of the Ministry of Health Committee is unsatisfactory, in

view of the great importance to the profession of the work entrusted to that Committee, and accordingly instructs the Council to take immediate steps to convert the Ministry of Health Committee into a Standing Committee elected in the same manner as the Medico-Political Committee.

By BUCKINGHAMSHIRE DIVISION:

That in the event of a medical man having two cars, and who uses only one at a time, the licence for the second car should be halved.

That an adequate travelling allowance be paid in connexion with attendance at a coroner's court, and that the fee for giving evidence should be two guineas, and for a necropsy three guineas, also that these fees should apply to the staffs of hospitals.

By GLASGOW EASTERN DIVISION:

That the principle of federation be agreed to, but confined to bodies limiting their membership to medical men.

By GLOUCESTERSHIRE DIVISION-BRANCH:

That the Representative Body is of the opinion that the Association should agree to appoint accredited representatives to the Federation of Medical and Allied Societies.

By LEICESTERSHIRE AND RUTLAND DIVISION:

That the words "or any allied science," and "or any allied profession" in new Article 6 (b) be omitted.

That the words "or any allied science" and "or any allied profession" in new Article 7 (b) be omitted.

That Representation at the Annual Representative Meeting be based on the number of Members of the Division on December 31st preceding the Annual Representative Meeting.

By NORTH SUFFOLK DIVISION:

That the British Medical Association should become a federation of medical bodies alone.

By MID-CHEESHIRE DIVISION:

That the Representative Body disapproves of any attempt to procure federation or affiliation between the British Medical Association and any non-medical body.

That the Representative Body considers the insurance record cards are unnecessarily irksome and impracticable, and that the scheme by Dr. Locket as published in the BRITISH MEDICAL JOURNAL SUPPLEMENT of February 19th, 1921, be considered by the meeting.

That the Representative Body is of opinion that the lay press should be excluded from the Annual Representative Meeting, but that a *précis* of the proceedings should be supplied to them for publication.

ELECTION OF COUNCIL OF ASSOCIATION, 1921-22.

A LIST of the Groups of Branches in the United Kingdom for election of twenty-four Members of the Council, 1921-22, and **Nomination Form**, were published in the SUPPLEMENT of March 12th (p. 73). The **Nominations** must be in the hands of the Medical Secretary **by May 16th**.

The result of the election for Members of Council by the Groups of the Oversea Branches was published in the SUPPLEMENT of February 19th, 1921.

ELECTION OF REPRESENTATIVE BODY OF ASSOCIATION, 1921-22.*Constituencies in Representative Body.*

THE Council has finally grouped the **Home Divisions** for election of the Representative Body; 1921-22, in the same manner as for 1920-21, except that the Caithness

and Sutherland Division of the Northern Counties of Scotland Branch, and the Rotherham and Sheffield Divisions of the Yorkshire Branch have been made independent Constituencies.

As intimated to all the **Oversca Bodies**, the Council has made each Oversea Division and Division-Branch an independent Constituency.

Election of Representatives and Deputy-Representatives.

The REPRESENTATIVES AND DEPUTY-REPRESENTATIVES in the Representative Body must be elected not later than June 17th, and their names notified to the Medical Secretary not later than June 24th. The Annual Representative Meeting at Newcastle begins on July 15th.

Special attention is drawn to the fact that the election of Representative(s) and Deputy-Representative(s) may, at the discretion of the Constituency, be carried out by General Meeting of the Constituency, or by postal vote.

SCHOLARSHIPS AND GRANTS IN AID OF SCIENTIFIC RESEARCH.

SCHOLARSHIPS.

The Council of the British Medical Association is prepared to receive applications for Research Scholarships as follows:

1. An ERNEST HART MEMORIAL SCHOLARSHIP, of the value of £200 per annum, for the study of some subject in the department of State Medicine.
2. THREE RESEARCH SCHOLARSHIPS, each of the value of £150 per annum, for research into some subject relating to the Causation, Prevention, or Treatment of Disease.

Each scholarship is tenable for one year, commencing on October 1st, 1921. A Scholar may be reappointed for not more than two additional terms.

The Conditions of the award of Scholarships are stated in the Regulations, a copy of which will be supplied on application to the Medical Secretary of the Association, 429, Strand, London, W.C.2.

GRANTS.

The Council of the British Medical Association is also prepared to receive applications for Grants for the assistance of Research into the Causation, Treatment, or Prevention of Disease. Preference will be given, other things being equal, to members of the medical profession, and to applicants who propose as subjects of investigation problems directly related to practical medicine.

The Conditions of the award of Grants are stated in the Regulations, a copy of which will be supplied on application to the Medical Secretary of the Association, 429, Strand, London, W.C.2.

Applications.

Applications for Scholarships and Grants for the year 1921-22 must be made not later than Saturday, June 25th, 1921, in the prescribed form, a copy of which will be supplied by the Medical Secretary on application.

Each application should be accompanied by testimonials, including a recommendation from the head of the laboratory, if any, in which the applicant proposes to work, setting out the fitness of the candidate to conduct such work, and the probable value of the work to be undertaken. This is not intended, however, to prevent applications for Grants in aid of work which need not be performed in a recognized laboratory.

LIBRARY OF THE BRITISH MEDICAL ASSOCIATION.

A LIST of periodical publications, official reports, and Blue Books in the Library of the British Medical Association available for issue to members on loan has been printed, and copies can be obtained free on application to the Librarian at the house of the Association, 429, Strand, W.C. The regulations governing the loan of these publications are stated in the introduction to the list. The Library is open for consultation from 10 a.m. till 6.30 p.m. (on Saturdays 10 a.m. till 2 p.m.).

BRANCH AND DIVISION MEETINGS TO BE HELD.

DORSET AND WEST HANTS BRANCH.—The annual meeting of the Dorset and West Hants Branch will be held at Yeovil on Wednesday, May 18th, at 3 o'clock, when the Presidential address, on "Experience of Two Recent Methods of Treatment,"

will be delivered by Dr. F. C. Bottomley, O.B.E. Luncheon will be served at 1.30 p.m. at the Three Coughs Hotel, the retiring President, Dr. Wetherall, in the chair. Dr. Norman Flower kindly invites members to tea after the meeting. A motor coach has been arranged to take members from the Bournemouth district, leaving The Square at 10.30 a.m. prompt. Applications for seats should be made early to Dr. Asten, Talbot Hill, Bournemouth.

METROPOLITAN COUNTIES BRANCH: SOUTH-WEST ESSEX DIVISION.—The annual meeting and dinner of the Division will be held on Thursday, May 19th.

METROPOLITAN COUNTIES BRANCH: WESTMINSTER DIVISION.—A general meeting of the Westminster Division (which includes Holborn) will be held on May 6th at 4.30 p.m. at the St. James's Vestry Hall, Piccadilly (next St. James's Church). Dr. G. F. Buchan will give an address on "National Health and the Practitioners," to be followed by a discussion. Officers will be elected for the coming year, and the names of gentlemen desirous of serving on the Executive Committee should be sent to the Honorary Secretary, Dr. F. D. Bennett, 15, Savile Row, W.1.

A MEDICAL PROVIDENT SCHEME.

SUGGESTED ORGANIZATION FOR LONDON.

In the BRITISH MEDICAL JOURNAL of January 22nd, 1921, p. 129, an account was given of the Sussex Provident Scheme, which had been drawn up for the purpose of supplying its members with medical facilities of every kind. The scheme was approved by four meetings of the medical profession at Brighton, Hove, and Preston, called to consider it—namely, by meetings of the Executive Committee of the Brighton Division of the British Medical Association, of the Brighton Panel Committee, of the honorary medical and surgical staffs of the hospitals concerned, and of the medical and dental professions generally. The facilities arranged under the scheme were set out in the JOURNAL of January 22nd, and the rules for those participating in the scheme were printed in full.

SCHEME OF THE METROPOLITAN COUNTIES BRANCH COUNCIL.

An amended form of the Sussex scheme has now been drafted by the Council of the Metropolitan Counties Branch of the British Medical Association. It is headed: "National Provident Scheme for Hospital and Additional Medical Services: Draft of Suggested Organization for London." The scheme is described in the following memorandum, issued by the Branch Council from the Head Office of the Association, 429, Strand, and bearing date April 18th, 1921:

1. *The Problem.*

The great and increasing cost and complexity of medical services beyond the attendance of a general practitioner have made it impossible for a large majority of the population to obtain these benefits, although it is obvious that many cases cannot be properly dealt with unless the doctor in charge has them at his disposal. It therefore becomes a choice of either having to do without them or of accepting them wholly or in part as charity.

Further, many of the Voluntary Hospitals are already obliged to charge for their services, and have decided to ask all out-patients to bear part of the outgoing cost of their treatment, and in-patients to contribute, according to their means, to their maintenance in Hospital.

2. *Hospital Co-operation.*

But it can now be made possible, by the help and co-operation of the Hospitals, to meet these difficulties by the establishment of a provident scheme which will supply its members, free of cost, with practically all the resources of medicine which can be afforded.

All the General and Special Voluntary Hospitals in the City and Metropolitan Police Districts should be eligible to accept the Scheme; but the management of the Scheme should be in the hands of an independent Central Office.

There should be adequate Medical representation upon any Body concerned in starting or working the Scheme.

3. Scope of Scheme.

It should be clearly understood, however, that this Scheme

- (1) Has nothing whatever to do with the National Health Insurance or any other organisation for medical benefit; and
- (2) Does not provide its members with ordinary medical (*i.e.*, general practitioner) attendance, or other benefit to which they are entitled from the State or from local authorities; but
- (3) Is for the benefit of those who, irrespective of class or occupation, are in a financial position which makes them eligible for election as members.

4. Income Limit.

The maximum limit of income for all persons admitted to the Scheme in the Metropolitan Area should be, in the present value of money, £250 for single members, £400 for married people without children, or for a widow or widower with one child, and £500 for a family (but including only those children under 16 years of age).

The higher income limits should have reference to the combined earnings of the family, and should be reducible to the lower income limits in cases where there cease to be children under 16 years of age dependent.

If it is found impracticable to distinguish between the incomes of persons insured under the National Health Insurance Acts, the income limit should not apply to those persons.

5. Medical Examination.

No preliminary medical examination is considered necessary before the admission of an applicant.

6. Facilities.

The following facilities will be arranged:—

i. CONSULTATIONS.—The medical attendant of a member may arrange, by appointment, for consultations separate from other patients at any of the co-operating hospitals, and such treatment as he and the consultant may jointly think advisable will be undertaken, at the hospital if this should be necessary.

For those members who are unable to leave their beds, the services of visiting consultants (a list of whom will be kept at the offices) may be secured by appointment.

For members outside prescribed areas, unable to leave their beds, free consultations may be obtained by appointment, subject to the payment to the consultant at the time of consultation of a charge equal to one half of the usual mileage rates.

ii. NURSING.—The full range of services of the "Queen's" or other Provided Visiting Nurses will be available for members at the request of their medical attendants.

iii. DENTAL TREATMENT.—Members sent by their medical attendant will be supplied with all ordinary dental treatment which may be considered necessary by the Dental Surgeon, and with any dentures which may be required at Hospital rates.

iv. LABORATORY.—All the resources of the Pathological Laboratories of the Hospitals will be available for the benefit of members after consultation, including bacteriological and pathological investigations and examinations beyond the province of general practice, Wassermann and Widal tests, &c., blood examinations and counts, the preparation of autogenous vaccines, &c.

v. X-RAYS.—Examinations will be available at the request of the medical attendant of a member, and where found necessary will be made, and a report supplied to the doctor. Treatment by X-rays (including opaque meals with examinations) will be given when, after consultation, it has been considered advisable.

vi. MASSAGE will be provided by appointment for members in whose cases it is prescribed after consultation.

vii. ELECTRICAL TREATMENT—*i.e.*, galvanism, faradism, high-frequency, ionization, diathermy, &c.—will be administered by appointment, after consultation, in suitable cases.

viii. HOSPITAL TREATMENT.—Urgent cases will be admitted to hospitals as at present: other cases requiring operation or other hospital treatment will, after consultation, be admitted to hospital, or be placed upon the waiting list of the hospital until there is a vacant bed, but a member will not take precedence over more urgent cases, and the ordinary hospital

routine will not be disturbed. In all the co-operating hospitals in which private beds are reserved at present for paying patients, members will be admitted to these beds, if available, should they desire it, at a uniform reduction of one guinea a week from the usual price of the bed.

In the case of Out-Patients any member of the Scheme showing his card of membership and presenting an introduction from his Practitioner will not be subjected to any Almoner's enquiry.

ix. AMBULANCES.—Will be available at the request of the medical attendant for the transport of "Stretcher Cases."

7. Access to Facilities.

The facilities of the services should only be available on the application of the General Practitioner, with the approval, when applicable, of the member of the Hospital Staff concerned.

8. Rules.

1. No one will be accepted as a single member except an unmarried man or woman, or a widower or widow without children under the age of 16.

The subscription for a single member will be £1 per annum.

2. Married people without children, or a widower or widow with only one child under the age of 16 years, may only subscribe jointly at a rate of £1 10s per annum for the two, although each shall be accounted a member.

3. Married people with a child or children under the age of 16, or a widower or widow with children under the age of 16 years, may only subscribe at a family rate of £2 per annum, which shall include the whole family, however large, except children over the age of 16, who must be accepted as single members, although each individual in the family shall be accounted a member.

N.B. These rates are subject to revision after due notice.

4. All candidates for membership must be approved by the "Committee of Reference" formed by the co-operating hospitals, except in the case of those insured under the National Health Insurance Acts, who will produce their medical card.

In the event of the eligibility of any member being questioned the matter will be submitted to the "Committee of Reference," whose decision shall be final.

5. Cards of membership, bearing the date, will be issued on the first day of each month to those who have become members during the preceding month, and the benefits will begin on the date of the card, and continue for one calendar year. These cards must be produced as evidence of membership.

6. At the end of one year from the date of issue of the membership card the benefits will cease unless the subscription has been renewed. Fourteen days grace will be given for renewal (during which no benefit will be available), but, after this, renewed membership will only be possible from the beginning of the next quarter.

7. When the number of members has reached the limit of the capacity of the co-operative hospitals, the list will be closed.

9. Financial Aspect of the Scheme.

It is estimated that in the area under consideration the number of persons to whom the scheme is applicable could not be less than 5,000,000; and that if all these joined, as individuals, married persons, or families, as the case might be, the resulting income would be about £3,000,000 per annum. If as a basis for calculation it is assumed that sufficient persons join to produce an income of £1,200,000, this might be allotted as follows:—

	£
Hospitals 52/80	750,000
(including 25% to Staff Fund, £195,000)	
500 Nurses 6/80	90,000
30 Ambulances 2/80	30,000
Visiting Consultants 8/80	120,000
Administration 3/80	45,000
Reserve 9/80	135,000
	Total £1,200,000

THE ANNUAL MEETING AT NEWCASTLE.

THE following is a summary of the arrangements for the eighty-ninth Annual Meeting of the British Medical Association to be held next July at Newcastle-on-Tyne. The proceedings will open on Friday morning, July 15th, when the Representative Body will begin its annual meeting at 10 o'clock, the session being continued on the three following weekdays. Council meetings have been provisionally fixed for the mornings of Monday, July 18th, and Wednesday, July 20th. The statutory annual general meeting will be held at 2 p.m. on Tuesday, July 19th, on which day the social and scientific business of the annual meeting will commence with the delivery by Professor David Drummond of his Presidential Address to the Association at 8 p.m. The sectional meetings for scientific and clinical work will be held, as usual, on the Wednesday, Thursday, and Friday; the mornings from 10 a.m. to 1 p.m. being given up to discussions, and the afternoons from 3 to 4.30 o'clock to clinical and laboratory demonstrations, of which a special feature will be made, as was the case at Cambridge last year. The list of sections and their presidents is printed below. The first five sections will meet on July 20th, 21st, and 22nd; the six following sections on two days each; and the remaining six sections on one day each.

Medicine: Professor Thomas Beattie.
Surgery: Professor J. Rutherford Morison.
Pathology and Bacteriology: Professor Stuart McDonald.
Preventive Medicine with Industrial Diseases: Sir Thomas Oliver.
Orthopaedics and Diseases in Children: Mr. A. H. Tubby.

Neurology and Psychiatry (July 20th and 21st): Professor A. W. Mackintosh.
Obstetrics and Gynaecology (July 21st and 22nd): Professor R. P. Ranken Lyle.
Ophthalmology (July 20th and 21st): Professor J. D. Wardale.
Oto-Rhino-Laryngology (July 20th and 21st): Dr. G. William Hill.
Physiology, Pharmacology, Therapeutics, and Dietetics (July 20th and 21st): Dr. H. H. Dale.
Venereal Diseases (July 20th and 21st): Colonel L. W. Harrison.

Ambulance and Red Cross (July 20th): Sir James Cantlie.
Dermatology (July 21st): Dr. J. Farquhar Christie.
Medical Sociology (July 22nd): Sir Jenner Verrall.
Proctology (July 20th): Mr. J. P. Lockhart-Mummery.
Radiology and Electro-Therapeutics (July 22nd): Dr. Robert Knox.
Urology (July 22nd): Mr. J. W. Thomson Walker.

There will be religious services on Tuesday, July 19th, at 5 p.m. On Wednesday evening at 8 o'clock Sir Thomas Oliver will give an address on industrial diseases; on the same day the secretaries will hold their annual conference at 2 p.m., and their dinner at 6.30 p.m. The annual dinner of the Association will be held on Thursday evening, July 21st, at 7.30 p.m., and on Friday Professor Arthur Keith will deliver the Popular Lecture at 7.30 p.m. on "Evolutionary wounds, their healing and the part they play in the evolution of the human body." Saturday, July 23rd, the last day of the meeting, has been set apart for excursions to places of interest in the neighbourhood. Articles on the history, institutions, and industries of Newcastle have appeared in the *JOURNAL* of December 11th, 1920, March 12th and April 16th, 1921, and information about hotel accommodation was given in the *SUPPLEMENT* of April 16th. The Honorary Local General Secretary is Mr. R. J. Willan (6, Kensington Terrace, Newcastle-on-Tyne).

INSURANCE.

LONDON PANEL COMMITTEE.

Annual Dinner.

THE London Panel Committee held its first annual dinner on April 21st, at the Holborn Restaurant, when some 150 ladies and gentlemen were present, with Dr. H. F. CARDALE, chairman of the Local Medical and Panel Committee for London, in the chair. After the loyal toasts had been honoured, the toast of "The London Panel Committee" was proposed by Dr. R. E. CROSSE, of the Ministry of Health. He pointed out that unanimity in

the medical profession was necessary, and he thought that there was a growing disposition to choose leaders to make known the views of the profession and to trust those leaders. Panel Committees had more power than they realized, and if they were to put forward, in conjunction with other Panel Committees, well-considered proposals, they could consolidate the position of the panel doctor. In reply to the toast, Dr. CARDALE said that the London Panel Committee might have received abuse from both sides, but it steered a middle course. Dr. J. A. ANGUS, who also replied, took the opportunity of making a strong attack on the new medical record card system. The toast of "The Ladies" was proposed in a witty speech by Dr. LAURISTON E. SHAW, who considered that the husbands of the growing number of married medical women and of women in public life deserved much sympathy, and that they were assuming the status and position of the mid-Victorian wife. Dr. ETHEL BENTHAM did not agree with Dr. Shaw. She congratulated the Committee on having arranged a family reunion instead of a formal public dinner, and hoped it would have many annual successors.

During the dinner an excellent musical programme was carried out by Miss Olive Sturgess, Mr. Fred Curtis, and others, and by Mr. Tom Bacon's orchestra. After dinner a dance was held, in which most of the company took part. Dr. R. J. Farman, Dr. Hands, and the other members of the Committee who were responsible for the arrangements are to be congratulated on a successful and enjoyable evening.

HOSPITALS AND INSURED PATIENTS.

A MEETING between members of the executive of the British Hospitals Association and representatives of some of the largest approved societies in the United Kingdom was held on April 22nd at Grosvenor Place, under the chairmanship of Viscount Hambleden. The meeting was called for the purpose of considering the possibility of a working agreement between the hospitals and the approved societies, whereby institutional treatment would be provided for members of the societies in return for contributions from the societies in the form of an agreed percentage.

It was agreed that the executive of the British Hospitals Association should ascertain the views of hospitals throughout the country as to (1) whether they were prepared to accept from the societies an agreed percentage of the cost of treating their members, as in- or out-patients; (2) whether they were prepared to agree that a payment, direct or indirect, equivalent in value to such percentage should be required by the hospitals in respect of treatment afforded to members of societies not so contributing; and (3) whether, assuming equal urgency for in-patient treatment on the part of persons desiring the same, some measure of priority should be given to members of contributing societies.

If the hospitals generally are favourable to giving preferential treatment to members of approved societies in return for a percentage contribution, the parties will meet again to draft a scheme.

CORRESPONDENCE.

Mileage under the Insurance Acts.

SIR,—Country practitioners must feel grateful for the way in which the British Medical Association has pressed their case in respect of mileage. It must always be difficult to press the requirements, however just they may be, of a minority group in the profession. The Association has done this with two beneficial results. The system that has been adopted has been good, and the sum allocated has been considerable.

Progress has been made, to the gratification of those who have hoped for it, without having to resort to violent and dictatorial methods.—I am, etc.,

Cornwall, April 25th.

J. C. JONES.

Naval and Military Appointments.

ROYAL NAVAL MEDICAL SERVICE.

THE following appointments are announced by the Admiralty: Surgeon Commanders: L. C. Rowan-Robinson, J. P. H. Greenhalgh, J. McA. Holmes and C. H. L. Petch to the *Pembroke* additional (temporary); A. La. T. Darley, G. Nunn, A. H. H. Vizard, J. H. Lightfoot, and A. B. Marsh to the *Victory* additional (temporary); A. J. Hewitt, C. H. J. Robinson, and W. P. Walker to the *Tivid* additional (temporary); C. R. Rickard to the *Victory* additional; W. R. Harrison, O.B.E., to the *Thunderer* on commissioning. Surgeon Lieutenant Commanders: P. N. Burton and A. R. Shaerod to the *Pembroke* additional (temporary). R. A. W. Ford to the *Tivid* additional (temporary). Surgeon Lieutenant A. W. North to the *Thunderer* on commissioning.

ARMY MEDICAL SERVICE.

Colonel S. A. Archer, C.M.G., is placed on retired pay on account of ill health contracted on active service.

ROYAL ARMY MEDICAL CORPS.

Lieut. Colonel M. W. Falkner retires on retired pay on account of ill health contracted on active service.

Major M. J. Cromie is placed on the half-pay list on account of ill health.

Major J. Mackenzie to be temporary Lieutenant-Colonel whilst specially employed.

Captain R. Ellis, M.C., retires, receiving a gratuity, and is granted the rank of Major.

The following officers relinquish their commissions: Temporary Captains and retain the rank of Captain: W. F. Gardener, J. C. Ducaason.

ROYAL AIR FORCE.

MEDICAL BRANCH.

Captain G. W. J. Bousfield is transferred to the unemployed list.

INDIAN MEDICAL SERVICE.

Lieut.-Colonel P. F. Chapman, C.I.E., M.B., appointed to officiate as Inspector-General of Civil Hospitals, Central Provinces, in addition to his own duties, March 1st.

Lieut.-Colonel J. C. H. Leicester, M.D., F.R.C.S., Professor of Midwifery, Medical College, Calcutta, has been granted, with effect from March 15th, combined leave for eight months.

Major V. B. Green-Armstrong, appointed to officiate as Professor of Midwifery, Medical College, Calcutta, during the absence on leave of Lieut.-Colonel J. C. H. Leicester.

Lieut.-Colonel W. V. Coppinger, D.S.O., M.D., F.R.C.S.I., Professor of Ophthalmic Surgery, Medical College, Calcutta, has been granted, with effect from February 15th, combined leave for eight months.

Captain P. K. Ghroy, M.B., appointed to officiate as Professor of Ophthalmic Surgery, Medical College, Calcutta, February 21st.

Colonel H. Austen Smith, C.I.E., M.B., Inspector-General of Civil Hospitals, Bihar and Orissa, has been granted, with effect from the date on which he may avail himself of it, combined leave for eight months.

Lieut.-Colonel R. H. Maddox, C.I.E., M.B., appointed to officiate as Inspector-General of Civil Hospitals, Bihar and Orissa, with effect from the date on which he assumes charge of that office.

Lieutenants to be Captains: F. R. Thornton, M.C., G. B. Mallya, F. M. Kirwan, V. N. Agate, S. R. Prall, J. C. Chukerbuti, S. A. Phatak, B. H. Kamakaka, M. A. Jafarey, S. N. Mukand (February 25th).

The undermentioned officers have been permitted to retire from the service, with effect from the dates specified: Lieut.-Colonels J. C. S. Vaughan (January 24th), H. Bennett, M.B. (January 29th), W. W. Clemesha, C.I.E. (February 1st), Sir Leonard Rogers, Kt., C.I.E. (March 1st), and Captain J. H. G. White (February 5th).

TERRITORIAL FORCE.

ROYAL ARMY MEDICAL CORPS.

Major J. Ward, C.M.G., D.S.O., vacates the appointment of D.A.D.M.S., 44th (Home Counties) Division.

Major M. White, M.C., R.A.M.C., to be Adjutant of the R.A.M.C. School of Instruction, Welsh Division (T.F.)

To be Majors: Captain (Brevet Major) A. Walker, D.S.O., Captains D. S. Sutherland, F. L. Rowse.

The following Captains resign their commissions and retain the rank of Captain: B. G. Goodwin, E. G. Anderson.

1st London (City of London) General Hospital.—Major (Brevet Lieut.-Colonel) W. McAdam Eccles is restored to the establishment.

1st London (City of London) Sanitary Company.—Captain H. Holroyd resigns his commission and retains the rank of Captain.

DEFENCE FORCE.

ARMY MEDICAL SERVICE: R.A.M.C.

To be temporary Captain: A. M. Johnson, M.C.

To be temporary Lieutenant: P. Lloyd-Williams.

DIARY OF SOCIETIES AND LECTURES.

ROYAL COLLEGE OF SURGEONS, Lincoln's Inn Fields, W.C.—Museum Demonstration, Mon., 5 p.m., Professor Shattock: Atrophy.

ROYAL SOCIETY OF MEDICINE.—Section of Tropical Diseases and Parasitology: Mon., 8.30 p.m., Dr. A. F. MacCallan: Ankylostomiasis Campaign in Egypt, 1913-1915; Sir Leonard Rogers: Mortality and Prognosis of Cholera treated by the author's Hypertonic Saline Method. Section of Surgery: Subsection of Orthopaedics: Tues., 5 p.m., Cases of Special Interest or demonstrating Special Methods of Bone Grafting will be shown by Mr. E. W. Hey Groves, Mr. O. L. Addison, and others. Section of Obstetrics and Gynaecology: Thurs., 8 p.m., Annual General Meeting; Mr. Henry Curtis: Angioma of Vagina Spontaneously Evacuated; Dr. Russell Andrews: Specimens of Carcinoma Originating in an Adenomyoma of the Uterus; Discussion: The Causes and Treatment of Sterility, to be opened by Dr. A. E. Giles. Section of Laryngology: Fri., 4 p.m., Cases; 4.45 p.m., Annual General Meeting.

POST-GRADUATE COURSES AND LECTURES.

GLASGOW POST-GRADUATE MEDICAL ASSOCIATION, Western Infirmary.—Wed., 4.15 p.m., Dr. B. Ness and Mr. A. Young: Medical Nervous Cases and Surgical Peripheral Nervous Cases.

MANCHESTER ROYAL INFIRMARY.—Tues., 4.30 p.m., Dr. W. Dyson: Tuberculosis of the Skin.

LONDON LOCK HOSPITALS.—Clinics daily. Lectures (at 91, Dean Street, W.1, Mon., 5 p.m., Mr. Gibbs: Ante-natal and Post-natal Treatment of Syphilis; Tues., 2.30 p.m., Mr. McDooagh: Clinical Demonstration; Wed., 4.30 p.m., Mr. Joly: Tests for Cure for Gonorrhoea in the Male; Thurs., 4 p.m., Dr. S. Phillips: Syphilitic Affections of the Kidney; Fri., 2.30 p.m., Mr. Thomson: Examinations of Chancres for *Spirillum pallidum*, etc.; 4 p.m., Mr. Abraham: Early Syphilitic Rash; (at 285, Harrow Road, W.), Wed., 3 p.m., Mr. Ernest Lane: Venereal Diseases in Women and Children.

NATIONAL HOSPITAL FOR THE PARALYSED AND EPILEPTIC, Queen Square, W.C.1.—Out-patient Clinics Daily, 2 p.m. (except Wed. and Sat.), Lectures—3.30 p.m., Mon., Dr. Saunders: Subacute Combined Degeneration of the Spinal Cord; Tues., Dr. James Taylor: Myasthenia Gravis; Fri., Dr. Collier: Hemiplegia; Thurs., Dr. Tooth: Demonstrations of Cases.

LONDON HOSPITAL MEDICAL COLLEGE, E.—Mon., 5 p.m., Dr. W. M. Feldman: Ante-natal and Post-natal Child Physiology; Tues. and Fri., 5.15 p.m., Dr. M. Culpin: Psychoneuroses.

WEST LONDON POST-GRADUATE COLLEGE, Hammersmith, W.—Daily, 10 a.m. (and Wed., 2 p.m.). Ward visits; 2 p.m., In- and Out-patient Clinics and Operations.

British Medical Association.

OFFICES AND LIBRARY, 49, STRAND, LONDON, W.C.2.

Reference and Lending Library.

THE READING ROOM, in which books of reference, periodicals, and standard works can be consulted, is open to members from 10 a.m. to 6.30 p.m., Saturdays 10 to 2.

LENDING LIBRARY: Members are entitled to borrow books, including current medical works; they will be forwarded, if desired, on application to the Librarian, accompanied by 1s. for each volume for postage and packing.

Departments.

SUBSCRIPTIONS AND ADVERTISEMENTS (Financial Secretary and Business Manager, Telegrams: Articulate, Westrand, London). MEDICAL SECRETARY (Telegrams: Medisecra, Westrand, London). EDITOR, *British Medical Journal* (Telegrams: Aitiology, Westrand, London).

Telephone number for all Departments: Gerrard 2630 (3lines).

SCOTTISH MEDICAL SECRETARY: 6, Rutland Square, Edinburgh. (Telegrams: Associate, Edinburgh. Tel.: 4361 Central.)

IRISH MEDICAL SECRETARY: 16, South Frederick Street, Dublin. (Telegrams: Bacillus, Dublin. Tel.: 4737 Dublin.)

Diary of the Association.

MAY.

- 3 Tues. London: Standing Subcommittee, Central Ethical Committee, 3 p.m.
6 Fri. London: Westminster Division, St. James's Vestry Hall, Piccadilly, 4.30 p.m.
13 Fri. London: Medico-Sociological Committee, 2.30 p.m.
18 Wed. Dorset and West Hants Branch, Annual Meeting, Yeovil, 3 p.m.; Luncheon, 1.30 p.m.
19 Thurs. South-West Essex Division: Annual Meeting and Dinner.

APPOINTMENTS.

FITZMAURICE-KELLY, M., M.B., B.S.Lond., F.R.C.S., Assistant Surgeon to the Royal Alexandra Hospital for Sick Children, Brighton.

TELFORD, E. D., F.R.C.S., Lecturer in Practical Surgery, University of Manchester.

YELLOWLEES, Henry, O.B.E., M.D., F.R.F.P.S.Glas., Medical Superintendent of the Retreat, York.

BIRTHS, MARRIAGES, AND DEATHS.

The charge for inserting announcements of Births, Marriages, and Deaths is 9s., which sum should be forwarded with the notice not later than the first post on Tuesday morning, in order to ensure insertion in the current issue.

BIRTHS.

FELDMAN.—On the 18th of April, at Abbotsford, 875, Finchley Road, Golders Green, N.W., to Hilda, wife of W. M. Feldman, M.D., a daughter.

MARR.—On April 12th, at 7, Vickers Street, Nottingham, to the wife of D. J. Marr, M.B., L.D.S., a daughter.

PRATT.—On Wednesday, April 20th, the wife of Dr. G. Wyatt Pratt, the Vicarage, Patricroft, Manchester, of a daughter.

MARRIAGES.

COX-HARRIS.—On the 26th April, at Cholmeley Hall, Highgate, Hedley Chase Cox, M.B., B.S., M.R.C.S., only son of Mr. and Mrs. Cox, of Penrhyn, Hornsey Lane, Highgate, to Francis Maude Mary, younger daughter of Mr. and Mrs. Harris, of Red Gables, Whetstone.

HAYMAN-EDWARDS.—April 25th, at St. Paul's Church, Forest Hill, by the Rev. J. R. Melhuish, Frank Keith Hayman, M.B., B.S., F.R.C.S. Eng., son of Mr. and Mrs. F. Hayman, 32, Apsley Road, Clifton, Bristol, to Mary Coslett, youngest daughter of the late Mr. Tom Edwards, Cefn House, Pentypridd, and Mrs. Evan Llewellyn, Tan-y-Bryn, Pentre Rhondda.

DEATHS.

BLENEARNE.—On April 10th, 1921, William L'Heureux Blenearne, M.R.C.S., L.S.A., of Ladbroke Lodge, Windsor Road, Worthing, aged 74 years.

BURTON BROWN.—On April 21st, at 112, Tonbridge Road, Maidstone, Gerald Burton Burton-Brown, M.D., retired R.N., youngest son of the late T. E. Burton-Brown, M.D., C.I.E.

FARQUHARSON.—Died in a Nursing Home at Newcastle-on-Tyne, on 23rd inst., Dr. Robert, the beloved husband of Marjorie Farquharson, of Glebe House, Washington.

SUPPLEMENT

TO THE

BRITISH MEDICAL JOURNAL.

LONDON: SATURDAY, MAY 7TH, 1921.

CONTENTS.

	PAGE		PAGE
BRITISH MEDICAL ASSOCIATION.		ANNUAL MEETING AT NEWCASTLE: Hotel and Hostel Accommodation 163	
CURRENT NOTES:		RETURN OF ATTENDANCES AT COUNCIL AND COMMITTEE MEETINGS 172	
ELECTION OF NEW COUNCIL	165	ASSOCIATION NOTICES 177	
DR. MACDONALD'S VISIT TO SOUTH AFRICA	165	MEETINGS OF BRANCHES AND DIVISIONS 173	
FEES FOR ADMIRALTY SURGEONS AND AGENTS	165	INSURANCE:	
EXEMPTION OF WOMEN JURORS	165	LONDON INSURANCE COMMITTEE	179
HOURS OF OPENING FOR THE LIBRARY	165	LONDON PANEL COMMITTEE	179
REGULATIONS AS TO RESEARCH SCHOLARSHIPS	166	NAVAL AND MILITARY APPOINTMENTS 179	
PAYING PATIENTS IN POOR LAW INFIRMARIES.		DIARY OF SOCIETIES AND LECTURES 180.	
DEPUTATION TO THE MINISTER OF HEALTH	166	ASSOCIATION INTELLIGENCE 180	
THE PROPOSALS FOR FEDERATION. DISCUSSION AT REIGATE	169	APPOINTMENTS... 180	
CORRESPONDENCE:		BIRTHS, MARRIAGES, AND DEATHS 180	
PROPOSED OPPORTUNITIES FOR AFFILIATING BODIES CON- SIDERED WITH ALLIED SCIENCES	171		
ANALYSTS' FEES IN INSURANCE PRACTICE	171		

British Medical Association.

CURRENT NOTES.

Election of New Council.

MEMBERS of the Association are reminded that Monday, May 16th, is the last day for the receipt at the Head Office, 429, Strand, of nominations for election of 24 members to the Council by the grouped Branches.

Dr. J. A. Macdonald's Visit to South Africa.

The presidential address given to the Witwatersrand Branch by Dr. R. P. Mackenzie, C.M.G., on January 20th, 1921, contained the following passage:

"The visit of Dr. Macdonald to this country as representative of the Central Council of the British Medical Association was, I think, of inestimable value. Dr. Macdonald was able to point out to us how great was the sympathy existing between the Central Council of the British Medical Association and the Oversea Branches. In fact, so great is this sympathy that the Central Council is prepared to grant even fuller independence and autonomy to the British Medical Association in South Africa, even to the extent of considering affiliation under a new name. Dr. Macdonald clearly pointed out, however, that the Central Council would be very loath to take this step, as it appeared to the Council to be cutting the painter, and would practically mean the complete secession of the overseas Branches from the British Medical Association. We have been told by Dr. Macdonald that we can be certain of one thing, and that is that our desires will always receive cordial and sympathetic treatment at the hands of the Central Council. Dr. Macdonald also made it clear that our powers under the Memorandum and Articles of Association were much wider than many of us realize."

Again, in the Annual Report of the Branch, presented by Dr. J. J. Levin, the Honorary Secretary, the following remarks on the subject are made:

"*Dr. Macdonald's Visit.*—There is no doubt that the most important occurrence during the year for the Witwatersrand Branch of the British Medical Association was the visit of Dr. Macdonald. Dr. Macdonald attended one Council and one Branch meeting, at both of which the advice he gave us has been of immense value to us. We are the stronger for his visit. While here, in one way or another, he was able to meet a very large number of the members of the Association, and we have no doubt that, as a result of his visit, the position of the British Medical Association in South Africa, and more particularly the position of the Witwatersrand Branch, will be better understood and better appreciated by the Council in London, and therefore strengthen the position of the Association as a whole."

Fees for Admiralty Surgeons and Agents.

The action of the British Medical Association in the matter of raising the remuneration of Admiralty surgeons and agents has at last borne fruit. Dr. W. E. Elliot, M.P.,

asked a question on this matter in the House of Commons on February 24th and was told that the matter was under consideration. He repeated the question on April 13th and was told that a revised scale of fees had been promulgated, with the exception of those for medical examinations, which are still under discussion. The revised scale of fees has now been received. From this it appears that an increase of approximately 50 per cent. has been granted. The consultation fee at the surgery has gone up from 2s. 6d. to 3s. 6d.; the visiting fee at a coastguard station or house has gone up from 2s. 6d. to 5s. for the first patient and 3s. 6d. for each succeeding patient; for visiting patients on board the fee for proceeding on board has gone up from 2s. 6d. to 3s. 9d., and the visiting fee per patient from 2s. 6d. to 5s. for the first patient and 3s. 6d. for each succeeding patient; mileage has gone up from 1s. to 1s. 6d. and is paid for any distance over the first mile one way only.

Exemption of Women Jurors.

The Women Jurors (Criminal Cases) Rules, 1920, provide that the number of women summoned for Quarter Sessions Court must be the same in proportion as the number of women bears to the number of men on the book from which jurors are selected, and the Clerk of the Peace ought to have in court ready to serve if required at least fourteen women jurors, because a woman prisoner may apply, and the court may grant her request, to be tried by a jury composed of women only. The Rules provide that the Clerk of the Peace may in his discretion excuse women who are pregnant or suffering from some feminine condition or ailment, and are therefore unfit to serve, and he is to be satisfied as to this by medical certificate or otherwise. Mr. Sydney Jones, Clerk of the Peace at Scarborough, has approached the Scarborough Division of the British Medical Association, asking for its help to enable him to perform his duties adequately and with as little disagreeableness as possible. If he could have some guarantee from the Division that the greatest care would be taken in the giving of such certificates, he thought it would meet the case if the certificate took the following form:

I certify that..... will be unfit to serve as a Juror at the next Quarter Sessions.

This certificate is issued in accordance with the provisions of the Women Jurors (Criminal Cases) Rules, 1920.

He pointed out to the Division that his suggestion only referred to women jurors and to ailments particular to women, and that he relied on the local profession, if they accepted his suggestion, to make it possible for him to carry out his duties carefully and yet at the same time to obviate the disclosure of certain facts which some women might refuse to have disclosed even if it meant their

attendance at court with injury to themselves. The Scarborough Division has accepted Mr. Sydney Jones's suggestion, and is circularizing all the local members of the profession on the subject; it has forwarded this information to the Head Office in the hope that it may be of use in other areas.

Hours of Opening for the Library.

Last year arrangements were made to meet the general convenience of members, whereby the Central Library would remain open until 8.30 p.m. on ordinary week days and 2 p.m. on Saturdays. Very many members having availed themselves of the facilities thus afforded, the Council proposes to continue the experiment of the extra hours for an additional period of one year.

Regulations as to Research Scholarships.

The regulations as to the Association's Research Scholarships have hitherto provided, *inter alia*, that a scholarship of the British Medical Association may be held concurrently with another scholarship, but that the scholar shall not receive from the Association a sum greater than the amount required to bring the total sum received during one year to £250. Having regard to present economic conditions, the Council has increased the foregoing figure to £400.

PAYING PATIENTS IN POOR LAW INFIRMARIES.

DEPUTATION FROM THE BRITISH MEDICAL ASSOCIATION TO THE MINISTER OF HEALTH.

A DEPUTATION from the British Medical Association waited upon the Minister of Health (the Right Hon. Sir Alfred Mond, M.P.) on April 26th to discuss the development of the schemes, which are either contemplated or in operation, for the admission of paying patients to Poor Law infirmaries. The deputation consisted of the following:

The Right Hon. Sir Clifford Allbutt (President), Dr. R. A. Bolam (Chairman of Council), Mr. N. Bishop Harman (Chairman of Hospitals Committee), Dr. J. A. P. Barnes, Dr. A. C. Farquharson, M.P., Dr. T. W. H. Garstang, Dr. E. W. G. Masterman, Surg.-Captain Meaden, R.N. (retd.), and Mr. E. B. Turner, together with Dr. Alfred Cox (Medical Secretary), Dr. N. G. Horner (Assistant Editor, *British Medical Journal*), Dr. G. C. Anderson (Deputy Medical Secretary) and Dr. C. C. Lord (Assistant Medical Secretary).

The Minister was accompanied by:

The Earl of Onslow (Parliamentary Secretary), Sir Arthur Robinson (First Secretary), Sir Aubrey Symonds (Second Secretary), Sir George Newman (Chief Medical Officer), Dr. J. Smith Whitaker (Senior Medical Officer), Mr. L. G. Brock, C.B., and Mr. H. W. S. Francis (Assistant Secretaries), and Mr. Douglas Veale (Private Secretary).

SIR CLIFFORD ALLBUTT said that he hoped he might be permitted, at this their first meeting since the changes in the Cabinet, to congratulate Sir Alfred Mond upon his new office. He would like to say quite clearly whom the deputation represented. It represented—he thought he might fairly say—the medical profession. The claim that the British Medical Association included every practitioner in the country would not be true, but he thought that few practitioners would be found to deny that, speaking broadly, the Association represented the interests of them all. Sir Alfred Mond might not be aware that they had a meeting of an exceedingly strong body of representatives from every part of the country once a year or oftener. He might add that the Association was not a narrowly medical body. Those who guided its affairs were reasonable and sociable persons who were always open to consider—perhaps he ought to say, to consider in the first instance—the interests of the public in general, and not alone the interests of the profession. The relations of the Association with the Ministry of Health had been very amicable. The Association so far had worked in harmony with the Ministry, with the creation of which it had had a good deal to do, and he was quite sure that good feeling would continue. He did not wish it to be thought that the Association was in any way connected with the more or less irresponsible and often carping criticisms levelled against the Ministry. If by chance the Minister heard it stated—as he was afraid it had been stated—that the Association was in

antagonism, or partially so, to the Ministry, he hoped that Sir Alfred Mond would wait until he heard what the Chairman of Council had to say before he gave credence to such a report. Whatever might be said here and there in irresponsible places, he begged the Minister to believe that, speaking generally, they were in cordial sympathy with what the Ministry had so far done.

Dr. R. A. BOLAM said that, as Chairman of Council, the chief executive body of the Association, he might be allowed to amplify in one or two details what the President had stated. He wished to introduce the Association as an organized body of medical men with a history of ninety years behind it, but also as a modern organization which had its branches throughout the kingdom and the empire, and was equipped with modern machinery for ascertaining the opinion of its members. As the President had said, the Association not only took its part in medical organization and medico-politics, but it did not neglect the advancement of the science and art of medicine. It was the only body which held an annual medical congress, and it possessed the most influential medical journal in the empire. It was in constant touch with various Government departments—the War Office, India Office, Ministry of Pensions, and the like. Inquiry from these departments would show the activities of the Association in everything which affected every section of the medical profession. But it was only natural that the Association should have special interest in the Ministry of Health, not only because it was specially concerned with medical affairs, but because the Association had for many years been vitally interested in the constitution and formation of such a Ministry. Even so far back as 1868 the Association made what was perhaps the first suggestion for a Ministry, and it took a very active part in the campaign which finally led to the Ministry's formation. The great problem of health insurance and its medical benefits had naturally brought the side of the Ministry which dealt with these matters into close and continuous contact with the Insurance Acts Committee of the Association during recent years. They had, therefore, on all counts a very vital concern in the welfare of the Ministry. They might, perhaps, often disagree with its actions, and would not then scruple to tell the Minister of the day firmly—but, he trusted, always courteously—their ground for such disagreement. Nevertheless, they took this opportunity to dissociate themselves quite emphatically from certain recent attacks upon the Ministry and its chief medical and other officers; the attacks apparently sprang from quarters where it must be assumed that there was political animus or mistaken zeal for unwise retrenchment. They wished the Minister to understand that these attacks did not come from the medical profession as a whole, or, indeed, from anyone with whom they were in touch who carried any weight or authority with the profession. They realized that in the present state of the affairs of the nation it was incumbent upon any Minister that he should move slowly in matters of reform, but it was their duty as medical men to protest strongly against the curtailment of services which they had advocated as essential for the health of the community, and to urge progress where such could be economically undertaken. In the past (Dr. Bolam continued) they had not always agreed with the Chief Medical Officer of the Ministry and his staff. It was not to be expected that in the future agreement would always be possible, but they did know that these officers, from their dealings with them and from their writings, were honest and able public servants—(Hear, hear)—and they had confidence that the Minister would ensure that proper scope and opportunity were not denied them. In conclusion, he would like to say, in the words of one who in his day was a pioneer in sanitary medicine and a zealous servant of the State, that their one hope and aim was that the day had at last dawned when the personnel of the Ministry—of such a Ministry as that—and the members of the medical profession “shall work together, some in lines of scientific study and others in lines of political principle, so that statecraft and medical knowledge shall sincerely take counsel together for the health of the people.”

Mr. BISHOP HARMAN said that the points which the deputation had come to discuss with the Minister con-

cerned one branch of the hospital problem of the country. It was well known how difficult the hospital problem had been of recent years. To the problem of the voluntary hospitals, their accommodation, and maintenance, there was now added the problem of the Poor Law infirmaries, or, as some of them were called, municipal hospitals. During the war the buildings were largely used for military purposes, and since then these institutions had not reverted quite to their old position, but there had been a tendency to widen their scope. He was proud of the Poor Law infirmaries—at any rate those with which he was acquainted in London—and he was second to none in admiration of their buildings, staffs, equipment, and medical arrangements. But when he said that he always said it with a tone of regret, because these hospitals were not in the main stream of the medical practice of this country. Very few people in speaking of hospitals thought at all of the Poor Law infirmary, or, if they did, they considered it part and parcel of the hated Poor Law system. Technically these institutions were still part of the Poor Law, but their position in recent times had changed to a considerable extent. Patients could now be admitted who were not technically paupers. Not so long ago a body of medical men had interviewed some of the staff of the Ministry to urge upon them that accommodation might be provided in Poor Law institutions for infants suffering from ophthalmia neonatorum. He himself had also recently successfully pressed the claims of sick children who suffered from certain serious diseases, and admission to the Poor Law institution in this case, as in the other, did not make them paupers. Technically the institutions were still for the destitute poor, but everything depended on the interpretation of the word "destitute." In the old days "destitute" had been held to mean those without money, but it might relate specifically to medical necessities. If for any reason a man was not able to get himself attended to when sick, he was "destitute" within that definition. This had now become the view of certain boards of guardians in this country, and thirteen of these authorities had made it known that they were prepared to receive into their infirmaries persons who were not financially destitute but who were able to pay for what they received. Those present that day welcomed this development to a certain extent; it enlarged the field for dealing with the sick. But they wished to make some suggestions as to the arrangements which should be made before these schemes were officially acknowledged, if the Minister decided to acknowledge them at all. The first desirable thing was that in any arrangement the local medical profession, who would be most affected, and in whose hands the success or failure of the scheme must lie, should necessarily be consulted. He believed that the Ministry approved of that attitude in general, and he hoped that the Minister would be so impressed by its desirability in this instance as to give a general instruction or recommendation to all the authorities that they should follow it in practice. They would find the local profession keenly interested and thoroughly willing to help them in their endeavours. He would like all municipal hospitals to have attached to their administration an *ad hoc* committee, composed of representatives of the medical profession and of the municipal body, so that the wheels of the machinery might be greased by direct conference. The second point was that if these hospitals were thrown open to a wider *clientèle*, who did not come by way of the receiving officer, such patients should only be admitted on the recommendation of the practitioner who was attending them. He, of course, excluded accident and emergency cases, but the general rule should be that a case could only be admitted on the recommendation of a practitioner. Some of those for whom he was speaking wanted an income limit instituted, but if it was laid down that a doctor must recommend the case it would sufficiently prevent abuse and to some extent do away with the necessity for an income limit. The third point related to what would happen after the patient was admitted. At present the staffs of the infirmaries consisted of whole-time officers who, because they were whole-time, were to some extent cut off from their professional brethren in the district. It was desirable that that wall of separation should be broken down, and this object could best be attained by allowing a certain number of beds to be relegated to wards which might be recognized as wards where patients were attended

by the doctor of their choice. That arrangement, to borrow Board of Education phraseology, might be known as "right of entry."

Sir ALFRED MOND: That would really be establishing a claim for the doctor in the infirmary?

Mr. BISHOP HARMAN: It would be something like the provision of a private nursing home in the infirmary.

Sir ALFRED MOND: What about the nursing service, the provisioning and so forth?

Mr. BISHOP HARMAN said that if these separate wards were established certain special arrangements would have to be made, which were matters of detail; but the medical superintendent of the institution would be in sole administrative control, and his voice would be first and last in all administrative affairs. They wanted this to be fully understood. The visiting doctor would only be allowed to come and go at certain definite hours. It was very desirable that the medical superintendent should have a knowledge of the cases received in, so that in an emergency his help would be available for the patient. The proposed arrangement was almost paralleled by that which obtained in the big voluntary hospitals, where members of the staff submitted to the regulations of the resident medical officer as to the time at which they should attend and the procedure for dealing with patients. This "right of entry" would make the Poor Law infirmary approximate in some respects to the primary health centre of the Dawson Report. Mr. Bishop Harman referred in conclusion to the altered financial circumstances of a large section of the community, which made it extremely difficult for them to provide themselves with proper medical attention. The middle classes had rarely gone to the voluntary hospitals and had never dreamed of going to the Poor Law infirmary, and many people in those classes were now at their wits' end to get proper accommodation in sickness. They could not afford private nursing homes, the fees of which had gone beyond the capacity of, say, the poor parson or the clerk earning £500 or £600 a year. Some nursing homes were finding it more remunerative partly to close down and let off a part of their accommodation as flats. Another point was that the arrangement proposed would cost nothing to the State; indeed, the State might profit by it. It might be possible to capitalize the cost of the institution, and include in the fee for maintenance a portion of the overhead charges for running the institution. The Hospitals Committee of the Association had drawn up a series of recommendations which they had had the advantage of discussing with certain medical superintendents of Poor Law infirmaries, and some of the recommendations had been discussed by the Association of Medical Superintendents, and on the whole there was a fair basis of agreement. He hoped that a recent letter sent by the Ministry to the board of guardians at Barnet need not be taken to rule out the suggestions he had brought forward.

The Minister's Reply.

Sir ALFRED MOND thanked Sir Clifford Allbutt and the deputation generally for their courtesy in meeting him. He wished to say, in the first place, a few words on the more general question. The Chairman of Council had thought it necessary to inform him as to the importance of the British Medical Association. He could assure them that he and those associated with him at the Ministry were all well aware of the strong position and power of that body as representing the medical profession. He was very glad indeed to hear of their sympathetic feelings towards the Ministry, and to know that he might count upon the help of the Association. The burden of responsibility upon the Minister of Health was great, and he felt that his predecessor, being a medical man, was to that extent better qualified than a layman could possibly be to deal with these subjects. Still, he could assure them that he had the health side of the Ministry very much at heart, and he hoped to do something towards developing that health side, which, after all, was still only in the embryonic state, for he did not think that anybody would claim that it was as yet fully developed or even fully thought out. With regard to the questions specifically put to him that day, he had listened with great interest to what Mr. Bishop Harman had so lucidly put forward. The whole hospital situation was, as they knew, by no means satisfactory. Owing to the generosity of private individuals and

the generosity of the medical profession, our voluntary hospitals had been, he supposed, second to none, if not superior to any run on State or municipal lines in other countries. So much could be said for the continuation of voluntary effort in these matters that unless they were driven to it in the last resort, he did not think anyone would acquiesce in the disappearance of the voluntary system. No doubt the financial difficulties to-day were oppressive, but it was permissible to hope that the financial difficulties would not always be with them. A great many people found it impossible to enter nursing homes, and were looking for some institution which would enable them to get requisite medical and nursing attendance on terms within their means. Something, of course, had been done in this direction by the general hospitals. He believed that St Thomas's for a great many years had taken in paying patients, and he hoped that plan might be developed. In Continental countries such as France and Germany, and also in America, nobody would hesitate for a moment about going into the great municipal hospitals, where, they knew, the most scientific treatment and highly skilled nursing would be available. Probably the people in this country might make more use of the general hospitals.

The question of the Poor Law infirmary was a new one, and was coming to the front. The whole question of Poor Law administration had been in the melting-pot for many years—for more years than he cared to remember. Any fundamental change, of course, could not be effected by administration, but would require new legislation. So far as the Ministry could meet the ideas expressed by the deputation it was endeavouring to meet them. The principle of consultation with the local profession had been put into practice in cases like Bradford, and he thought it was a useful line to take. On the other hand, they could only advise boards of guardians, not compel them; they could only endeavour to bring them into what seemed a very good line to follow. With regard to the other points, the deputation would not expect a very definite reply from him on that occasion. He would very carefully consider these questions, but he saw that they raised difficulties. The admission of patients into a municipal hospital only on the recommendation of a general practitioner had certain practical advantages, but there might be considerable difficulties in individual cases. What if a patient wanted to go into a particular institution and his doctor refused to recommend him, whereupon he changed his doctor, and found another more amenable to his wishes? That would not be very satisfactory; it might create difficulty between doctors and patients, resulting in a raising of temperatures! At any rate, the idea would need to be very carefully considered. There might be objections also, if this plan were taken as an alternative to an income limit, to making the doctor the judge of a patient's financial position. Doctors were doubtless in a fairly good position for knowing whether or not a man could be a paying patient, but this might mean placing upon the doctor the responsibility for an examination more suitable to a chartered accountant than to a medical man. He was not rejecting the idea, but he did want to point out that it had its difficulties and to suggest that it was possible a certain friction might be created which later on they would be inclined to regret. He had been interested in Mr. Harman's third suggestion (allowing doctors to follow their patients into the infirmary), but he could give no opinion as to how far this could be put into practice. He had been engaged very closely on the Tuberculosis Bill, as well as upon non-health concerns of his department and of the Government—the industrial situation for one thing—and he had had no opportunity as yet to go into the technical side of these questions, but he would give them in due course his personal attention, with a view to being as helpful and sympathetic as the circumscribed powers of the Ministry would enable him to be. Perhaps at some future time they would have the opportunity of a fuller discussion. He was glad to have the assistance of so practical and representative a body as the British Medical Association, and he would be pleased to receive a deputation at any time when they had a proposal to make or when any difficulty arose in their common work upon which assistance and counsel might be offered. (Applause.)

Sir CLIFFORD ALBUTT thanked the Minister, and the deputation then withdrew.

EIGHTY-NINTH ANNUAL MEETING

OF THE

British Medical Association.

NEWCASTLE, JULY, 1921.

HOTEL AND HOSTEL ACCOMMODATION.

The Hotels, Lodgings, and Billeting Committee feel confident that they will be able to put up all those who are coming to the meeting in spite of the difficulty that has been experienced in getting accommodation. They would strongly emphasize, however, the necessity for making early application for rooms at the hotels. Already one or two hotels have ceased booking, and are not now published. The management of the County Hotel has been particularly generous in placing a large number of rooms at the disposal of doctors attending the conference. Some have twin-beds and some have double-beds, and the manager stipulates that such rooms must have two occupants. There are also single rooms. The hotels at Whitley Bay have been approached, and it is arranged that a number of rooms there are to be placed at the disposal of doctors. These are only to be reserved till June 1st, after which they will be let to their regular patrons. Whitley Bay is a most popular seaside resort, only a short train journey from Newcastle, and members are advised to make early application for these rooms. Applications for accommodation at any of the hotels outside Newcastle should be made to the representative of the Hotels, Lodgings, and Billeting Committee resident in that town. The names and addresses of these doctors are published in each case.

Many of the hotels included in the list given below are short distances out of Newcastle, and are specially suited for members who intend to make their visit coincide with their annual holiday. Details as to distance and train service are inserted, so that members may judge of their convenience in attending sectional meetings and evening functions. It is possible, of course, that the train services may be modified before the date of the meeting, and the hotel tariffs quoted are also liable to alteration. The prices quoted are for single persons per night. Members, when making application for rooms at hotels, should head their note-paper "Annual Meeting, British Medical Association."

ADVANCE LIST OF HOTELS.

NEWCASTLE-UPON-TYNE.

	Bed and Breakfast.	Lunch.	Dinner.
Turk's Head	11/-	3/-	5/-
County	9/6	3/-	4/6
Douglas (a few double rooms)	12/6	3/6	6/-
Central Exchange	8/-	2/6	4/6
Tyne Temperance (a few double rooms)	9/-	—	—
Market (a few rooms with two beds and some single rooms. Strictly commercial, not suitable for ladies)	6/6	—	—
Clyde (a few rooms with two beds)	8/-	—	—
Sun	8/-	3/-	—
Norfolk (a few double rooms)	8/-	3/-	—

Several of the above hotels, as indicated, do not give lunch or dinner. There are abundant restaurants in the town where such meals can be obtained, as also at the other hotels included in the list.

St. Margaret's	10/6	3/-	4/-
Imperial	10/6	3/-	5/-
Kensington	8/6	2/6	3/6
Osborne	10/6	3/6	5/-

These hotels are chiefly residential. They each expect to have a number of rooms available at the date of the meeting.

Teas can be had at all the hotels mentioned above, and some will quote terms which are inclusive for the day or week. Particulars could be obtained by application to the Manager. All these hotels are within a short distance of the Reception Room.

WHITLEY BAY.

Popular seaside resort; bathing, boating, etc. On coast, close to Tynewood. Train service: journey, half an hour by electric train, every quarter or half hour. Late trains available till 11.45 p.m.

Waverley	9/-	3/-	4/-
Royal	10/6	4/-	5/-
Avenue	10/-	3/6	5/-
Esplanade (a number of rooms with twin beds)	8/6	3/6	6/-

Local Representative: Dr. N. R. Rawson, Rydal House, Esplanade, Whitley Bay.

TYNEMOUTH.

Popular seaside resort. Attractions and train service are the same as for Whitley Bay. Journey 24 minutes.

	Bed and Breakfast.	Lunch.	Dinner.
Bath Hotel	8/-	3/-	7/6
Moria House (Barling House, Mrs.) St. n. Bury, Slyn street, Tynemouth	6	—	2/6

Local Representative: Dr. J. A. Hislop, Public Health Offices, Tynemouth.

DURHAM.

Train service: 40 minutes slow; 20 minutes express. Morning trains convenient, and last train 10.50 p.m.

County: Bed and breakfast, 10/6; inclusive charge per day, £1 1s.
 Three Inns: Bed and breakfast, 9/-; inclusive charge per day, 17 6.
 Rose and Crown: Bed and breakfast, 8/-; inclusive charge per day, 16/-
 Other meals can be obtained at the above hotels.
 Avenue Hotel (Temperance): Terms moderate.

Local Representative: Dr. F. V. T. Hare, The Avenue, Durham.

SOUTH SHIELDS.

Frequent train service: journey 34 minutes. Convenient trains. Last train 11.50 p.m.

Golden Lion	8/6	3/6	4/6
Regent	8/6	2/6	5/-
Royal	10/6	4/-	5/-

Local Representative: Dr. W. Campbell Lyons, 11, Ogle Terrace, South Shields.

SUNDERLAND.

Seaside resort. Golf, etc. Numerous and convenient trains; journey 22 minutes (express). Last train from Newcastle, 11.18 p.m.

Grand	8/6	3/-	4/-
Queen's	8/6	3/6	4/6
Royal	8/-	2/6	4/6
Park Hotel	8/6	4/6	4/6

Local Representative: Dr. H. Boyd Cunningham, 13, Ward Terrace, Sunderland.

HEXHAM.

Very beautiful old market town, abounding in natural and historical interest. Situated on the Tyne about twenty miles from Newcastle. Golf, etc. Convenient and frequent trains; journey, 55 minutes express; 50 minutes slow. Last train 9.50 p.m.; 10.45 p.m. Thursdays only.

Hydropathic. Special terms for doctors attending the meetings, 12/- per day.
 Royal 8/-
 Abbey 8/6 (Inclusive charge per day, 14/-)

Local Representative: Dr. J. A. Jackson, Carntyne, Hexham.

CORBRIDGE.

A lovely residential spot in the beautiful Tyne valley, about five miles east of Hexham, and of great archaeological interest. Train service: Express 40 minutes; convenient morning trains. Last train from Newcastle 9.50 p.m.; 10.45 p.m. Thursdays only.

Wheatsharf } Bed and breakfast, between 5/- and 7/5.
 Tynedale
 Angel

Local Representative: Dr. D. N. Jackson, Bridge House, Corbridge.

MORPETH.

Another fine old market town. Train service: Express 40 minutes; convenient trains. Last train from Newcastle 8.55 p.m.; 10.52 p.m. Thursdays only.

George and Dragon } Terms on application.
 Queen's Head
 New Phoenix

Local Representative: Dr. H. O. Dickie, Ward House, Morpeth.

CHOLLERFORD.

Quiet and picturesque village, near Roman wall and camp; 26 miles from Newcastle. Fishing, motoring.

The George: For terms apply to the Manager.

The hotels at Hexham, Morpeth, Corbridge, and Chollerford are on main roads to Newcastle, and would be very well suited for doctors bringing their cars with them. Many of the hotels quote reduced figures for double rooms when shared by two people. Inquiry should be made about this when engaging rooms.

EASTON HALL, ESKDALE TERRACE, JESMOND, NEWCASTLE.

This students' hostel has been very kindly put at the disposal of the Association. It is in the residential quarter of Newcastle and quite near the Reception Room. The rooms, though small, are very comfortable, and there are writing and reception rooms. Each room has a single bed and only men can be taken. There are several tennis courts in the grounds which would be available for the members. All the rooms will be available from Monday, July 18th, to

Saturday, the 23rd, but only ten will be at the disposal of the members from July 14th to the 18th.

Terms: Bed and breakfast, 8s. if member stays longer than two nights, 10s. if staying for one or two nights only. Tea (1s.) and dinner (3s. 6d.) will be provided if sufficient notice is given each day. Apply for rooms to Dr. E. F. Murray, 52, Jesmond Road, Newcastle-upon-Tyne.

A list of the hostels and colleges at Durham will be published in the near future.

Medical Women.

Those who propose to come to the meeting and have any difficulty in finding accommodation are requested to communicate with Dr. Ethel Williams, 3, Osborne Terrace, Newcastle-on-Tyne, who is Chairman of the Lady Doctors' Subcommittee.

The Chairman of the Hotels and Lodgings Committee is Dr. H. KERR, O.B.E., and the Honorary Secretary, Dr. E. F. MURRAY, 52, Jesmond Road, Newcastle-upon-Tyne. (Telephone: 916 Jesmond.)

THE PROPOSALS FOR FEDERATION.

DISCUSSION AT MEETING OF THE REIGATE DIVISION.

A MEETING of the local Division was held at the Redhill and Reigate Hospital on April 27th to consider the line of policy to be urged by its Representative at the Annual Representative Meeting on the question of federation of the British Medical Association with other medical and possibly also non-medical bodies (see SUPPLEMENT, March 5th, and leading article in the JOURNAL of April 30th, 1921). Dr. C. S. CRICHTON, the new Chairman, was in the chair, and Dr. E. R. Fothergill of Hove, who was present by invitation, and Dr. S. Morton Mackenzie, the retiring Chairman, were the openers of a debate in which they took opposing sides.

Dr. MORTON MACKENZIE held that the proposal to make the British Medical Association a federation of medical and allied bodies was unnecessary and dangerous. The history of the matter was that three or four years ago it was found desirable, purely for Association purposes, to give power to the Australian Branches to dissolve themselves as Branches and become separate incorporated bodies, but remaining federated with the Association. The reasons for this course were mainly legal; as Branches they could not hold property in Australia, and there were other anomalies and disadvantages. That the course was not taken out of antagonism to the parent Association was sufficiently evidenced by the fact that, although becoming legally separated, these former Branches desired to remain federated. The demand was acceded to on the recommendation of the Organization Committee, but a further resolution of the Representative Body, in the form of an instruction to the Council, opened up the wider question of the alteration of the By-laws of the Association so that societies in the United Kingdom, both medical and allied, might become federated with the Association. This project had been minutely discussed at headquarters, and would be the subject of a full discussion at the Representative Meeting in July. With the federation or affiliation of the Overseas Branches the speaker was cordially in sympathy, but to the wider idea of federation he was opposed. He did not believe that, so far as the federation of non-medical societies was concerned, more than a small section of the members of the Association favoured the proposal. It had been urged as a criticism by the Federation of Medical and Allied Societies that the British Medical Association embraced only 52 per cent. of the medical profession in its membership.

Lieut.-Colonel HOWARD MUMMERY interjected that the Federation had never put forward that figure of 52 per cent. on its own responsibility, but had quoted it from figures given by the Medical Secretary.

Dr. MACKENZIE said that while the figure was true of the Register as a whole, the proportion of medical men in actual practice who were members of the Association was much higher; he was not sure that it was greatly below 90 per cent. He did not believe that the Minister of Health dare do anything as regards medical men without consulting the Association, and he failed to see, as an out-and-out British Medical Association man, that the bringing in of outside societies would strengthen the Association in any particular, even though the societies thus brought in were confined to those consisting wholly of medical men. It was always possible by an

amicable arrangement to go to the Government on joint deputation with medical bodies specifically representing certain interests, and the effectiveness of this procedure would not be increased by actual federation. It was suggested that the federated societies should have representation on the Council and on the Representative Body. Was it desirable that the Association should transform its machinery into an omnibus collection of medical groups? The Association at present was in a very strong position. It could reply even to those who urged trade unionism that eminent publicists in Mr. and Mrs. Webb had held it up as a pattern for strength and efficiency. He strongly urged that, apart from this distinct matter of the Overseas Branches, federation should be definitely excluded from the programme.

Dr. E. R. FOTHERGILL said that no one could impugn his loyalty to the Association; it could be proved from the records of his work for the last nineteen years. Nor would he admit that he was fathering something quite alien from the original principles of the Association. A reference to its Articles and By-laws would show that its object when it was founded was "to promote the medical and allied sciences." He preferred the term "affiliation," which suggested a paternity attitude, to "federation," which suggested an equality attitude. Two considerations must be borne in mind. In the first place, in the course of years groups of men and women with common interests tended to crystallize into unions or leagues for mutual protection. After each group had been formed it was pulled this way and that by extremists—some on the right wing, who were reactionary, others on the left wing, who were progressive. A strained situation went on for some time, when it usually happened that the left wing split off and formed a new body. That had taken place inside the profession as well as outside. It was taking place now. The second point to remember was that the medical profession no longer occupied the isolated position of a generation or two ago. The profession itself no longer completely controlled the situation. To a greater and greater extent public opinion decided the lines upon which medical work should be done. As matters stood at present, if the Association represented 52 per cent. of the entire profession, and other bodies could say that they represented 10 or 20 per cent., the result of proceeding on quite separate lines would be confusion, and the Minister would probably decide to go his own way without further reference to a disunited profession. Was it not better to come to some terms with these bodies by a working agreement, so that when a question arose affecting one section of the profession the body directly interested could come into council with the Association, and thus, after joint and representative conferences, the authoritative opinion of the profession could be brought before the Government? It was proposed that a particular medical body might have a representative on the Council and at Representative Meetings, where resolutions could be brought forward and deputations received; also that certain seats might be allocated on standing committees which dealt with matters affecting this particular interest, and, further, that whatever the Association was doing which had reference to this side of medical work should be communicated, along with all documents, to the federating society, which would be expected to do the same in return. With regard to non-medical bodies, he knew that here he was on thinner ice, but what was proposed was not in this case representation on the Council or at the Representative Meetings; it was only some share in the work of appropriate committees, as well as common action and disclosure in any problem that might arise. It was absolutely untrue to suggest that the governing bodies of the Association would be swamped with dentists, nurses, and other outside people. He was aware that it had been said that this proposal was prompted by the formation a year or two ago of the Federation of Medical and Allied Societies, but as a matter of fact it was the subject of a resolution in 1914 at the Aberdeen meeting, and was only held up by the war. He concluded by saying that the Association was great, but it could not afford to ignore any group or section. If nothing was done, the outside bodies would be a source of confusion and uncertainty in any negotiations. The groups should be brought into living touch with the Association, both centrally in London, and locally in the Branches and Divisions.

Dr. S. A. CLARKE said that he was one of the original founders of the Medico-Political Union, which body he left on account of its extreme views and its chaos in finance; but many of the Union members all the time kept up their connexion with the Association, and the same was

doubtless true of other bodies. He supported the federation idea because it made for unity and coherence.

Dr. MORTON MACKENZIE said that two years ago efforts were made to arrive at some kind of working arrangement with the Medico-Political Union, and the only terms on which the Union would co-operate were that the Association should give up all its medico-political work and keep to its scientific activities.

Dr. CLARKE challenged Dr. Mackenzie's statement, which, he said, did not quite represent the case. Long before the more recent negotiations the Union had approached the Association over and over again to discover a working basis, and was repulsed. They had here a body which was at first anxious to co-operate, practically without conditions; was frustrated; and then, growing in strength, asserted itself and proved refractory.

Dr. W. McD. ELLIS asked what guarantee they had that other bodies would accept fellowship if it were offered. The idea of federation or affiliation went against the grain with him, but if it was going to bring in those members of the profession who at present stood aloof, he would waive his own feelings.

Dr. FOTHERGILL, before leaving to catch his train, pointed out that it did not follow because they had the resolutions proposed by the Council for federation, that they took immediate action. Each individual case would be dealt with on its merits and would be a matter of separate negotiation. He could imagine that the whole process, if the principle was adopted, might yet take some years to complete.

Dr. R. M. HUGO supported the policy of federation, and Dr. C. H. J. WATSON criticized it, and asked whether, if the Association represented 50 per cent. of the profession and another body 10 per cent., they were to have an equal force in formulating policy.

Lieut.-Colonel HOWARD MUMMERY, Secretary of the British Federation of Medical and Allied Societies, said that his position there was simply that of a member of the British Medical Association attending a meeting of the Division where he resided. He wanted the membership of the Association to increase, and that was also the wish of his Federation. The Association should become as strong numerically as possible, but he thought it was expecting too much to have the whole profession in one organization. Medicine was split up into many distinct branches and interests, as much differentiated from each other—save for the fact of a common portal—as the medical profession and the profession of nursing. He thought that if certain medical societies were going to be given representation on the Council of the Association, together with other benefits and privileges, the result would be to cause the members of those societies who were already members of the Association to relinquish their membership of the latter. The federation scheme would weaken the Association numerically. The Branches in the Dominions might become separate organizations if they wished, but why should the home position be weakened by taking in other medical bodies? The best plan would be for the British Medical Association to join the Federation already in existence, where it would retain its autonomy and its great privileges, and have every advantage which it now sought by reorganization from within. There were many organizations in the profession more representative than the Association so far as sectional interests were concerned.

Asked to define the position of his Federation in its relation to the British Medical Association, Lieut.-Colonel MUMMERY said that only those who chose to do so made out that it was in antagonism. The Association itself was one of the bodies which met a large number of others on October 1st, 1918. Sir Jenner Verrall, representing the Association, voted for setting up such a body as the Federation. Then the Association put forward a claim itself to form and control that body, and here there was a difference of opinion. The majority of the societies did not agree with that view, and themselves formed the Federation, hoping that the Association would see its way to come in. So far from being in opposition, the Federation maintained that it was supplementary to the present organization of the Association. The Federation at the moment represented, with very few exceptions, all the other interests in the profession, and a united profession was immediately available if the Association would take the hand of fellowship, which was still extended.

Dr. MACKENZIE said that he would like to have another opportunity of a discussion with Lieut.-Colonel Mummery on this matter. His answer to the whole discussion was that if the Association decided not to enter into any federation, it still remained so strong that no Minister of Health could

embark on any new policy which affected medical men without consulting it. Many of the advantages which Dr. Fothergill had instanced as attaching to federation were already available: only last year the Representative Body devoted an afternoon to hearing a deputation from the Society of Medical Officers of Health. If the societies were federated with it, the Association would lose members. What would be the use of a member of a federating society retaining his membership in the society and in the Association as well? There was no evidence that any society wished to federate, save the Overseas Branches, whose case was not on all fours with what was proposed under the wider scheme.

Two motions were then put to the meeting on the proposition of Dr. MacKENZIE, seconded by Dr. WALSON. The first was to the effect that, except for the Overseas Branches, all medical bodies should be excluded from federation. This was carried by 10 votes to 5. The second was that all non-medical bodies should be similarly excluded, and this was carried, with one dissentient.

Correspondence.

Proposed Opportunities for Affiliated Bodies connected with Allied Science.

SIR, The Council, acting on the instructions of the Cambridge Representative Meeting, has prepared draft Articles and By-laws (SUPPLEMENT, March 5th) and Rules (SUPPLEMENT, April 30th) under which it would be possible for any body formed for the advancement of an allied science to become affiliated to the British Medical Association, if mutually desired, after due consideration in each case by the Representative Body on the report of its Council.

It is to be noted that certain Divisions have already registered their objection to the principle of affiliating such bodies before they can have had any opportunity to consider the proposed rules to govern this, as these have been published only this past week. Evidently these Divisions, from lack of this information, and possibly being misled by the vague Current Note of March 5th, had come to the conclusion that the proposals were that such bodies would have the right, if affiliated, to ask for seats on the Representative Body and Council, and for the members to attend the annual scientific meetings, thus swamping the medical profession's parliament and executive committee, as also its scientific congresses.

This is not so. On reference to these rules now appearing for the first time in the SUPPLEMENT of April 30th, pp. 149-150, it can be seen that all that is proposed to offer to such bodies, in addition to a few detailed benefits, are the following:

1. Permission to be heard by deputation by the Representative Body and Council.
2. A seat on any committee, subcommittee, conference, or deputation formed to deal with any subject affecting the honour or interests of those whom the body represents.

These proposals now made are, in fact, putting on record what already is carried out under the Association's Memorandum (Section 3 (I)), in our central organization.

Such bodies, if affiliated, would not have seats on the Representative Body nor on the Council, nor could they claim them under the proposed Articles, By-laws, and Rules.

The question, therefore, which each Division should ask itself when considering these two Supplements is, Does it approve the continuation of the loose co-operation with allied science bodies now being carried on and its registration under the new Articles, By-laws, and Rules? If still in doubt about the possibilities of swamping the Representative Body, Council, or annual scientific meetings, the Division should adopt in addition a resolution, to be placed before the Representative Body, instructing the Council to have the Articles and By-laws strengthened in order to prevent this if counsel considers that there is any ambiguity in the matter.

Might one urge the Divisions to reply to the query in the affirmative, and to adopt, if considered necessary, a resolution on the lines as suggested?—I am, etc.,

Hove May 2nd.

E. ROWLAND FOTHERGILL.

Anaesthetists' Fees in Insurance Practice.

SIR,—I should be glad if I might have the use of a short space to call attention to the recent circular letter of the Ministry of Health on the subject of remuneration for

anaesthetics.* If I am correct in my contention this is a matter which should engage the immediate attention of all Panel Committees.

Paragraph (a) of this letter authorizes payments out of the medical pool in respect of anaesthetics given in hospitals and "similar institutions." It is obvious that no payments can be made for services which the Acts and Regulations do not provide, and the deduction is equally obvious that a particular hospital service—namely, the giving of anaesthetics—is now held by the Ministry to be provided by the Acts. So far as I am aware, all previous rulings of the Ministry have stated quite definitely that no sort of hospital service is provided. If this is an intentional reversal of previous rulings the position is very serious, if it is accidental and likely to be with drawn, no time should be lost in demanding its reconsideration.

You will note that no payment may be made in respect of the administration of an anaesthetic unless the service in connexion with which it is given is also within the terms of service. Therefore the legalizing of payment for hospital anaesthetics incidentally brings within the terms of service the operations themselves although performed in hospital. And if anaesthetic and operation are within the terms of service, it is evident that the ordinary attendance in hospital must be similarly included. Such attendance then becomes the duty of the practitioner, whether or no he is a member of the hospital staff, and where a patient is in hospital outside his own area the regulations dealing with temporary residents would appear to come into force. Again, if an anaesthetic may be given in hospital as part of the services to which a patient is entitled by virtue of his being insured, the necessary chloroform or ether can be ordered at the expense of insurance funds.

Once a Panel Committee authorizes payment for any service given in hospital, it allows by inference that we are under contract to give services in hospital, for only in such cases could payments out of the medical pool be legal. I do not for one moment believe that our present contract includes any such services, and I am very sure that our present rate of remuneration was not calculated to include such services. Nevertheless the circular letter referred to contains the significant clause: "it is clearly undesirable that there should be any general action which should tend to an undue narrowing of the view taken by practitioners of their obligations under the terms of service." There is further in the model form provided for claiming payments for anaesthetics a space left for stating where the operation was performed—that is, whether in hospital or otherwise.

May I venture to suggest to Panel Committees that they pass and forward to the Ministry resolutions in some such form as the following:

The Local Medical and Panel Committees for the of have had under consideration the circular letter of the Ministry of Health on emergency treatment and anaesthetist's fees. They decline to accept the inference to be drawn from paragraph (a) of this letter that services rendered in hospitals and similar institutions can be held to be within the terms of service and so can be remunerated out of insurance funds. They request that Form G.P. 19 may be amended by the deletion of the line "Place where operation was performed" and the substitution of "I hereby declare that the operation was not performed in any hospital or similar institution."

I have little doubt that if we accept this letter we shall find its terms included in the next revision of the Regulations, when we shall find that we have agreed to a very large extension of service and have forfeited our present legitimate claim for a share in any funds provided by approved societies or from other sources for the support of hospitals.—I am, etc.,

Sevenoaks, May 2nd.

GORDON WARD.

* SUPPLEMENT, April 16th, 1921, p. 99.

LIBRARY OF THE BRITISH MEDICAL ASSOCIATION.

A list of periodical publications, official reports, and Blue Books in the Library of the British Medical Association available for issue to members on loan has been printed, and copies can be obtained free on application to the Librarian at the house of the Association, 429, Strand, W.C. The regulations governing the loan of these publications are stated in the introduction to the list. The Library is open for consultation from 10 a.m. till 6.30 p.m. (on Saturdays 10 a.m. till 2 p.m.).

[Appendix to the Annual Report of Council, printed in the SUPPLEMENT of April 30th, 1921.]

RETURN OF ATTENDANCES

At Council, Committee, and Sub-Committee Meetings, from the Annual Representative Meeting, 1920, to April 8th, 1921.

(Prepared pursuant to Standing Orders.)

COUNCIL.

Chairman: Dr. R. A. BOLAM.

NAME	ATTENDANCES.	
	Actual.	Possible.
President: The Rt. Hon. Sir T. Clifford Allbutt, K.C.B., LL.D., M.D., F.R.S., Cambridge	1	4
President-Elect: Dr. David Drummond, C.B.E., D.C.L., Newcastle-on-Tyne...	0	4
Chairman of Representative Meetings: Dr. T. W. H. Garstang, Altrincham	4	4
Chairman of Council: Dr. R. A. Bolam Newcastle-on-Tyne	4	4
Past-Chairman of Council: Dr. J. A. Macdonald, LL.D., Taunton	2	4
Treasurer: Dr. G. E. Haslip, London	4	4

Bailey, Dr. T. Ridley, Bilston	2	4
Barnes, Dr. J. A. P., London	4	4
Barr, Sir James, C.B.E., M.D., LL.D., Liverpool	3	4
Barry, Col. T. D., C.B.E., R.A.F., London	1	4
* Bone, Dr. J. W., Luton	2	2
Brackenbury, Dr. H. B., London	4	4
Bristowe, Dr. H. C., Wrigton	4	4
Buchanan, Col. Sir Walter, K.C.I.E., I.M.S. (Retd.), Dublin	1	4
Buttar, Dr. C., London	4	4
Coombe, Mr. Russell, Exeter	3	4
Darling, Dr. J. Singleton, Lurgan	4	4
Dawson, The Rt. Hon. Lord, G.C.V.O., K.C.M.G., C.B., London	2	4
* Don, Dr. James, Newcastle-on-Tyno	2	2
Eccles, Mr. W. McAdam, London	4	4
Elliot, Lieut.-Col. R. H., I.M.S. (Retd.), London	3	4
Ewart, Dr. David, O.B.E., Chichester	1	4
Farquharson, Dr. A. C., M.P., London	1	4
Forbes, Dr. A., Sheffield	4	4
Fothergill, Dr. E. R., Hove	4	4
Francis, Dr. H. A., London	2	4
† Fulton, Dr. Adam, Nottingham	1	1
Giusani, Dr. J., Cork	1	4
Goff, Dr. John, Windlesham	4	4
Harman, Mr. N. Bishop, London	4	4
Johnson, Dr. J. W., Bury	3	4
Johnstone, Mr. R. J., Belfast	1	4
Langdon-Down, Dr. R., Hampton Wick	4	4
Law, Dr. W. F., Dublin	2	4
Lawson, Dr. David, Banchoy	4	4
* Luce, Maj.-Gen. Sir Richard H., K.C.M.G., C.B., Derby	2	2
Mackenzie, Dr. S. Morton, Dorking	4	4
* Macpherson, Maj.-Gen. Sir Wm., K.C.M.G., C.B., London	2	2
Mactier, Dr. H. C., M.B.E., Wolverhampton	4	4
Meaden, Surg.-Capt. E. H., C.M.G., R.N. (Retd.), London	3	4
Peacocke, Dr. R. C., O.B.E., Blackrock	3	4
Pearson, Dr. C. M., Edinburgh	3	4
Radclyffe, Dr. Frank, Oldham	3	4
Robertson, Dr. C. E., Glasgow	2	4

Ross, Dr. D., London	4	4
Sheahan, Dr. D. A., Portsmouth	4	4
† Smiley, Dr. G. K., O.B.E., Derby	1	1
Smyth, Dr. W. Johnson, Bournemouth... ..	4	4
Snodgrass, Dr. W., Glasgow	4	4
Sprott, Dr. Gregory, Inverness	2	4
Stedman, Dr. F. O., Weybridge... ..	4	4
Stevens, Dr. John, Edinburgh	4	4
Treasure, Dr. W. B. Crawford, Cardiff	4	4
Turner, Mr. E. B., London	4	4
Turner, Dr. E. O., Great Missenden	3	4
Verrall, Sir Jenner, LL.D., Harpenden... ..	4	4
Walshe, Dr. Dennis, Craigue	2	4
Ward, Lieut.-Col. A. B., C.B.E., D.S.O., Nottingham	0	4

* Appointed December, 1920.

† Resigned October, 1920.

COMMITTEES.

FINANCE COMMITTEE.

Chairman: THE TREASURER.

NAME	ATTENDANCES.					
	Com. Meetings		Sub-Com Meetings		Total.	
	Actual	Possible	Actual	Possible	Actual	Possible
President	0	4	—	—	—	—
Chairman of Council	1	4	—	—	—	—
Chairman of Representative Meetings	4	4	—	—	—	—
Treasurer	4	4	—	—	—	—

Appointed by R.F.	Buttar, Dr. C., London	3	4	—	—	—	—
	D'Ewart, Dr. J., Manchester	4	4	—	—	—	—
	Lawson, Dr. D., Banchoy	2	4	—	—	—	—
	Lucas, Mr. Albert, Birmingham... ..	3	4	—	—	—	—
Appointed by Journal Com. by Council.	Brackenbury, Dr. H. B., London	4	4	—	—	—	—
	* Fulton, Dr. Adam, Nottingham	—	—	—	—	—	—
	† Galloway, Sir James, K.B.E., C.B., London	2	3	—	—	—	—
	Smyth, Dr. W. Johnson, Bournemouth	4	4	—	—	—	—
	Verrall, Sir Jenner, LL.D., Harpenden	4	4	—	—	—	—
	Barr, Sir James, C.B.E., M.D., LL.D., Liverpool	4	4	—	—	—	—
	Hawthorne, Dr. C. O., London	3	4	—	—	—	—
Chairman of Organisation Committee (Mr. Russell Coombe)	0	4	—	—	—	—	
Chairman of Journal Committee (Dr. J. A. Macdonald)	1	4	—	—	—	—	
Chairman of Medico-Political Committee (Mr. E. B. Turner)	4	4	—	—	—	—	
Chairman of Central Ethical Committee (Dr. R. Langdon-Down)	2	4	—	—	—	—	

* Resigned September, 1920.

† Appointed September, 1920.

ORGANISATION COMMITTEE.

Chairman: MR. RUSSELL COOMBE.

NAME.	ATTENDANCES.					
	Com. Meetings.		Sub-Com. Meetings.		Total.	
	Actual.	Possible.	Actual.	Possible.	Actual.	Possible.
President	0	4	—	—	0	4
Chairman of Council ...	0	4	0	11	0	15
Chairman of Representative Meetings ...	4	4	19	19	23	23
Treasurer	0	4	1	18	1	22
<i>Appointed by Council by R.E.</i>						
Baildon, Dr. F. J., Southport ...	3	4	4	4	7	8
Dryland, Dr. L. W., Kettering ...	2	4	5	5	7	9
Fothergill, Dr. E. R. Hove ...	3	4	10	11	13	15
Henry, Dr. R. Wallace, Leicester ...	2	4	12	15	14	19
Beadles, Dr. H. S., London ...	4	4	1	3	5	7
Barnes, Dr. J. A. P., London ...	—	—	—	—	—	—
Coombe, Mr. Russell, Exeter ...	2	4	10	19	12	23
Mackenzie, Dr. S. Morton, Dorking ...	3	4	9	16	12	20
*Buist, Dr. R. C., Dundee ...	0	3	0	5	0	8
*Lankester, Dr. C. P., Guildford ...	2	3	—	—	2	3
†Verrall, Sir Jenner, LL.D., Harpenden ...	3	4	11	11	14	15
‡Langdon-Down, Dr. R., Hampton Wick ...	0	3	5	11	5	14

*Co-opted September, 1920.

†Co-opted for consideration of Scrutiny Sub-Committee Minutes.

‡Resigned September, 1920.

JOURNAL COMMITTEE.

Chairman: DR. J. A. MACDONALD.

NAME.	ATTENDANCES.					
	Com. Meetings.		Sub-Com. Meetings.		Total.	
	Actual.	Possible.	Actual.	Possible.	Actual.	Possible.
President	0	4	—	—	—	—
Chairman of Council ...	4	4	—	—	—	—
Chairman of Representative Meetings ...	4	4	—	—	—	—
Treasurer	4	4	—	—	—	—
<i>Appointed by Council by R.E.</i>						
Hawthorne, Dr. C. O., London ...	3	4	—	—	—	—
Wallis, Mr. C. E., London ...	3	4	—	—	—	—
*Willock, Dr. E. H., Croydon ...	0	2	—	—	—	—
Barr, Sir James, C.B.E., M.D., LL.D., Liverpool ...	3	4	—	—	—	—
Macdonald, Dr. J. A., LL.D., Tamton ...	2	4	—	—	—	—
Smyth, Dr. W. Johnson, Bourne-mouth ...	4	4	—	—	—	—
Chairman of Central Ethical Committee (Dr. R. Langdon-Down)	0	4	—	—	—	—

† Resigned November, 1920

SCIENCE COMMITTEE.

The President:

NAME.	ATTENDANCES.					
	Com. Meetings.		Sub-Com. Meetings.		Total.	
	Actual.	Possible.	Actual.	Possible.	Actual.	Possible.
President	1	2	1	1	2	3
Chairman of Council ...	0	2	—	—	0	2
Chairman of Representative Meetings ...	1	2	—	—	1	2
Treasurer	0	2	—	—	0	2
<i>Appointed by Council.</i>						
Bolton, Dr. C., F.R.S., London ...	1	2	—	—	1	2
Buist, Dr. R. C., Dundee ...	2	2	—	—	2	2
Dixon, Prof. W. L., O.B.E., F.R.S., Wharfedale ...	2	2	—	—	2	2
Elliot, Lt. Col. R. H., J.M.S. (retd.), London ...	2	2	—	—	2	2
Haldane, Dr. J. S., LL.D., F.R.S., Oxford ...	1	2	1	1	2	3
Martin, Prof. C. J., C.M.G., F.R.S., London ...	2	2	—	—	2	2
Moore, Prof. Benjamin, F.R.S., Oxford ...	0	2	0	1	0	3
Turner, Mr. E. B., London ...	1	2	—	—	1	2
Dale, Dr. H. H., C.B.E., F.R.S., London ...	0	1	—	—	0	1

*Co-opted October, 1920.

CENTRAL ETHICAL COMMITTEE.

Chairman: DR. R. LANGDON-DOWN.

NAME.	ATTENDANCES.					
	Com. Meetings.		Sub-Com. Meetings.		Total.	
	Actual.	Possible.	Actual.	Possible.	Actual.	Possible.
President	0	3	—	—	0	3
Chairman of Council ...	1	3	—	—	1	3
Chairman of Representative Meetings ...	3	3	4	4	7	7
Treasurer	0	3	—	—	0	3
<i>Appointed by Council by R.E.</i>						
Lyndon, Dr. A., O.B.E., Hindhead	2	3	3	3	5	6
Maclier, Dr. H. C., M.B.E., Wolverhampton ...	3	3	—	—	3	3
Moore, Dr. Milner M., Eastbourne	3	3	3	4	6	7
Neal, Dr. James, London ...	3	3	4	4	7	7
*Orton, Dr. John, Coventry	—	—	—	—	—	—
Bristowe, Dr. H. C., Wrington	3	3	—	—	3	3
Goff, Dr. John, Windlesham ...	2	3	2	3	4	6
Jordan, Mr. J. Furneaux, Birmingham ...	3	3	—	—	3	3
Langdon-Down, Dr. R., Hampton Wick ...	3	3	4	4	7	7
*Smiley, Dr. G. K., Derby ...	—	—	—	—	—	—
†Taylor, Dr. M. R., London ...	—	—	—	—	—	—
†Crookshank, Dr. F. G., London ...	2	2	1	1	3	3
†Rice Osley, Dr. A. J., C.B.E., London ...	2	2	—	—	2	2
†Turner, Dr. E. O., Gt. Missenden	2	2	4	4	6	6

* Resigned October, 1920.

† Appointed October, 1920.

MEDICO-POLITICAL COMMITTEE.

Chairman: Mr. E. B. TURNER.

NAME	ATTENDANCES.						
	Com. Meetings		Sub-Com. Meetings		Total		
	Actual	Possible	Actual	Possible	Actual	Possible	
President	1	4	0	5	1	9	
Chairman of Council, ...	3	4	1	5	4	12	
Chairman of Representative Meetings	4	4	5	9	11	15	
Treasurer	1	4	2	5	3	12	
Appointed by R.E.	Bailey, Dr. T. Ridley, Bilston ...	4	4	7	7	11	11
	Flemming, Dr. C. E. S., Bradford-on-Avon ...	1	4	1	1	5	5
	Harman, Mr. N. Bishop, London ...	4	4	2	2	6	6
	Maetier, Dr. H. C., M.B.E., Wolverhampton ...	4	4	8	9	12	13
	Robertson, Dr. C. E., Glasgow ...	3	4	—	—	3	4
	Turner, Mr. E. B., London ...	4	4	5	15	9	19
	Beadles, Dr. H. S., London ...	4	4	1	1	5	5
	Brackenbury, Dr. H. B., London ...	4	4	4	4	8	8
	Bristowe, Dr. H. C., Wrigton ...	3	4	1	1	4	5
	*Fulton, Dr. Adam, Nottingham ...	—	—	—	—	—	—
Appointed by Council.	Treasure, Dr. W. B. Crawford, Cardiff ...	3	4	2	5	5	9
	Verrall, Sir Jenner, LL.D., Harpenden ...	4	4	7	8	11	12
	*Bone, Dr. J. W., Laton ...	3	3	3	3	6	6

*Appointed September, 1920.
†Resigned September, 1920.

PUBLIC HEALTH COMMITTEE.

Chairman: Dr. T. RIDLEY BAILLY.

NAME	ATTENDANCES.						
	Com. Meetings		Sub-Com. Meetings		Total		
	Actual	Possible	Actual	Possible	Actual	Possible	
President	1	4	—	—	1	4	
Chairman of Council ...	1	4	—	—	1	4	
Chairman of Representative Meetings	2	4	—	—	2	4	
Treasurer	1	4	—	—	1	4	
Appointed by R.E.	Dearden, Dr. W. F., Manchester ...	2	4	1	2	3	6
	Gold, Dr. D. Dryburgh, Hereford ...	3	4	2	2	5	6
	Lyndon, Dr. A., O.B.E., Hindhead ...	4	4	—	—	4	4
	Parker, Dr. G., Bristol ...	3	4	—	—	3	4
	Sanders, Dr. C., London ...	4	4	2	2	6	6
	Snell, Dr. E. H., Coventry ...	4	4	2	2	6	6
	Domville, Dr. E. J., O.B.E., Bridport ...	3	4	0	1	3	5
	Howarth, Dr. W. J., C.B.E., Longfield ...	1	4	1	2	5	6
	Jones, Dr. Herbert, Hereford ...	4	4	3	3	7	7
	Manknell, Dr. A., Bradford ...	3	4	—	—	3	4
Radeliffe, Dr. Frank, Oldham ...	3	4	—	—	3	4	
*Bailey, Dr. T. Ridley, Bilston ...	3	3	2	3	5	6	

*Appointed November, 1920.

INSURANCE ACTS COMMITTEE.

Chairman: Dr. H. B. BRACKENBURY.

NAME	ATTENDANCES.						
	Com. Meetings		Sub-Com. Meetings		Total		
	Actual	Possible	Actual	Possible	Actual	Possible	
President	0	5	—	—	0	5	
Chairman of Council ...	0	5	—	—	0	5	
Chairman of Representative Meetings	4	5	—	—	4	5	
Treasurer	3	5	—	—	3	5	
Appointed by R.E.	Beadles, Dr. H. S., London ...	5	5	2	2	7	7
	Dain, Dr. H. G., Birmingham ...	5	5	2	3	7	8
	Fothergill, Dr. E. R., Hove ...	3	5	3	3	6	8
	Hunter, Dr. J., Edinburgh ...	3	5	—	—	3	5
	Palmer, Dr. C. J., Mansfield Woodhouse ...	5	5	2	2	7	7
	Darling, Dr. J. Singleton, Lurgan ...	1	5	—	—	1	5
	Bailey, Dr. T. Ridley, Bilston ...	4	5	3	3	7	8
	Brackenbury, Dr. H. B., London ...	5	5	4	4	9	9
	*Cowie, Dr. H. G., London ...	0	3	—	—	0	3
	Dewar, Dr. M., Edinburgh ...	3	5	—	—	3	5
	Forbes, Dr. A., Sheffield ...	5	5	2	2	7	7
	*Goff, Dr. J., Winclesham ...	2	3	—	—	2	3
	§Fry, Dr. P. V., East Moseley ...	1	2	—	—	1	2
	Jones, Dr. Hugh, Dolgelly ...	3	5	2	3	5	8
	Launcester, Dr. C. P., Guildford ...	4	5	—	—	4	5
	*Linnell, Dr. A., Towcester ...	1	3	—	—	1	3
	Loeket, Dr. T. Wood, Melksham ...	5	5	3	3	8	8
	*Miles, Dr. T. G., Ruardean Oldham, Dr. H. F., M.B.E., Morecambe ...	2	3	0	1	2	4
	5	5	—	—	5	5
	Panting, Dr. C. H., London ...	4	5	1	2	5	7
Radeliffe, Dr. Frank, Oldham ...	5	5	—	—	5	5	
*Rutter, Dr. H. L., M.B.E., Newcastle-on-Tyne ...	1	3	—	—	1	3	
Williams-Freeman, Dr. J. P., Andover ...	5	5	3	3	8	8	
Harman, Mr. N. Bishop, London ...	4	5	—	—	4	5	
Ramsay, Dr. Mabel, Plymouth ...	3	5	—	—	3	5	
Hill, Prof. A. Bostock, Birmingham ...	2	5	—	—	2	5	
Green, Dr. A. Withers, London ...	4	5	—	—	4	5	
†Askin, Dr. T. Cuning, M.B.E., Woodbridge ...	2	2	1	1	3	3	
†Burkitt, Dr. J. C. S., Whitwich ...	2	2	1	1	3	3	
†Hillman, Dr. G. B., M.B.E., Wakefield ...	2	2	2	2	4	4	
†Hodgson, Sir W., Crewe ...	2	2	—	—	2	2	
†Martine, Dr. W. R., Haddington ...	1	2	—	—	1	2	
†Smith, Dr. A., Whickham ...	2	2	—	—	2	2	

*Membership ceased November, 1920.
§Resigned October, 1920.
†Appointed November, 1920.

OFFICE COMMITTEE.

Chairman: THE CHAIRMAN OF COUNCIL.

NAME	ATTENDANCES.					
	Com. Meetings		Sub-Com. Meetings		Total	
	Actual	Possible	Actual	Possible	Actual	Possible
Chairman of Council	6	6	—	—	6	6
Chairman of Representative Meetings ...	6	6	—	—	6	6
Treasurer	6	6	—	—	6	6

HOSPITALS COMMITTEE.

Chairman. Mr. N. Bishop Harman.

ATTENDANCES.

NAME.	Com. Meetings		Sub-Com Meetings		Total	
	Actual	Possible	Actual	Possible	Actual	Possible
	President	3	4	—	—	3
Chairman of Council	3	4	—	—	3	4
Chairman of Representative Meetings	1	4	—	—	1	4
Treasurer	3	4	—	—	3	4
Appointed by R.F.						
Campbell, Dr. H. J., Dartmouth...	4	4	—	—	4	4
Eason, Dr. J., Edinburgh...	2	4	—	—	2	4
Harman, Mr. N., Bishop, London	4	4	—	—	4	4
Reeles, Mr. W. McAdam, London	3	4	—	—	3	4
Wallace, Sir Cuthbert, K.C.M.G., C.B., London	1	4	—	—	1	4
Dunn, Dr. H. G., Birmingham	4	4	—	—	4	4
Galloway, Sir James, K.B.E., C.B., London	2	4	—	—	2	4
Johnson, Dr. I. W., Bury...	3	4	—	—	3	4
Masterman, Dr. E. W. G., London	4	4	—	—	4	4
Morison, Mr. A. E., Sunderland	1	4	—	—	1	4
Roper, Dr. F. A., Exeter	2	4	—	—	2	4
*Clarke, Dr. A. V., Leicester	1	4	—	—	1	4

* Appointed September, 1920.

DOMINIONS COMMITTEE.

Chairman. Dr. DAVID EWART.

ATTENDANCES.

NAME.	Com. Meetings		Sub-Com Meetings		Total	
	Actual	Possible	Actual	Possible	Actual	Possible
	President	0	2	—	—	0
Chairman of Council	0	2	—	—	0	2
Chairman of Representative Meetings	2	2	—	—	2	2
Treasurer	0	2	—	—	0	2
Appointed by R.F.						
(Cantle, Sir James, K.B.E., London	1	2	—	—	1	2
Greenlees, Dr. T. D., Fordingbridge	1	2	1	1	2	3
Johnson, Dr. I. W., Bury	1	2	—	—	1	2
Macdonald, Dr. J. A., LL.D., Tamerton	0	2	—	—	0	2
Elliot, Lt. Col. R. H., I.M.S. (retd.), London	2	2	1	1	3	3
Ewart, Dr. David, O.B.E., Chichester	2	2	1	1	3	3
Francis, Dr. H. A., London	2	2	—	—	2	2
Law, Dr. W. F., Dublin	2	2	—	—	2	2
Sprout, Dr. Gregory, Inverness	0	2	—	—	0	2
Stedman, Dr. F. O., Weybridge	2	2	—	—	2	2
Ward, Lieut. Col. A. B., C.B.E., D.S.O., Nottingham	0	2	—	—	0	2

SCOTTISH COMMITTEE.

Chairman. Dr. W. SNODGRASS.

ATTENDANCES.

NAVAL AND MILITARY COMMITTEE.

Chairman. Lt. Col. R. H. Elliot, I.M.S. (retd.).

ATTENDANCES.

NAME.	Com. Meetings		Sub-Com Meetings		Total	
	Actual	Possible	Actual	Possible	Actual	Possible
	President	0	2	—	—	0
Chairman of Council	0	2	—	—	0	2
Chairman of Representative Meetings	1	2	0	2	1	4
Treasurer	0	2	—	—	0	2
Appointed by R.F.						
Blandford, Col. L., C.B.E., Worcester	2	2	2	2	4	4
Goodbody, Capt. F.W., R.A.M.C.T., London	2	2	2	2	4	4
Battar, Dr. G., London	2	2	2	2	4	4
Elliot, Lt. Col. R. H., I.M.S. (retd.), London	2	2	2	2	4	4
Bury, Col. T. D., C.B.E., R.A.F., London	0	2	0	2	0	4
Buchanan, Col. Sir W. J., K.C.I.E., I.M.S. (retd.), London	1	2	—	—	1	2
Macpherson, Maj. Gen. Sir W. G., K.C.M.G., C.B., London	1	1	1	1	2	2
Meaden, Surg. Capt. E. H., C.M.G., R.N. (retd.), London	2	2	0	2	2	4

* Appointed December, 1920.

NAME.	Com. Meetings		Sub-Com Meetings		Total	
	Actual	Possible	Actual	Possible	Actual	Possible
	President	0	4	—	—	0
Chairman of Council	0	4	—	—	0	4
Chairman of Representative Meetings	0	4	—	—	0	4
Treasurer	0	4	—	—	0	4
Appointed by R.F.						
Alexander, Dr. T., Elgin	0	4	—	—	0	4
Buist, Dr. B. C., Dundee	2	3	7	7	9	10
Dickson, Dr. D. Elliot, Lochgelly	3	4	3	6	6	10
Frew, Dr. W. D., Kilmarnock	1	4	1	1	2	5
Fraser, Dr. T., Aberdeen	2	4	—	—	2	4
Allen, Dr. A. Kennedy, Glasgow	1	4	3	6	4	10
Goff, Dr. John, Waulsham	1	4	0	4	1	8
Hume, Dr. John, Perth	4	1	4	7	8	11
Hunter, Dr. J., Dumfries	2	4	0	1	2	5
Laekie, Dr. J. Lamond, Edinburgh	4	4	4	4	8	8
Lawson, Dr. D., Banbury	2	3	1	1	3	5
Miller, Dr. A. C., Fort William	0	1	—	—	0	1
Miller, Dr. J. B., Bishopbriggs	3	4	—	—	3	4
Pearson, Dr. C. M., Edinburgh	2	4	—	—	2	4
Ritchie, Dr. J., Glasgow	3	4	—	—	3	4
Robertson, Dr. C. E., Glasgow	2	4	2	1	4	8
†Smith, Dr. F. K., Aberdeen	1	1	3	4	4	5
Snodgrass, Dr. W., Glasgow	4	4	3	3	7	7
Stevens, Dr. John, Edinburgh	4	4	7	7	11	11
Thin, Dr. R., Edinburgh	3	4	—	—	3	4
†Cre, Dr. J. L., Tighnabruaich	1	1	—	—	1	1

* Elected November, 1920.
 † Elected March, 1921.

IRISH COMMITTEE.

Chairman: Dr. Denis WALSH.

NAME.	ATTENDANCES.					
	Com. Meetings.		Sub-Com. Meetings.		Total.	
	Actual.	Possible.	Actual.	Possible.	Actual.	Possible.
President ...	0	1				
Chairman of Council ...	0	1				
Chairman of Representative Meetings ...	0	1				
Treasurer ...	0	1				
} <i>ex-officio</i>						
Corby, Dr. H., Cork ...	1	1				
Costello, Dr. T. B., Galway ...	1	1				
Craig, Dr. J., Dublin ...	1	1				
Crymble, Mr. P. T., Belfast ...	0	1				
Darling, Dr. J. Singleton, Lurgan ...	1	1				
Doolin, Dr. W., Dublin ...	0	1				
Giusani, Dr. J., Cork ...	0	1				
Grace, Dr. Pierce, Kilkenny ...	0	1				
Heard, Dr. R. L., Monkstown ...	0	1				
Johnstone, Mr. R. J., Belfast ...	1	1				
Lee, Dr. P. G., Cork ...	0	1				
Mills, Dr. John, Ballinasloe ...	1	1				
*Murphy, Dr. W. W., Inch ...	1	1				
Peacocke, Dr. R. C., O.B.E., Blackrock ...	0	1				
*Power, Dr. J., Ardhanan ...	0	1				
Ryan, Dr. R. V., Carlow ...	0	1				
Walsh, Dr. D., Graigue ...	1	1				
*Warnock, Dr. H. T., Donegal ...	1	1				

* Co-opted October, 1920.

WELSH COMMITTEE.

Chairman: Dr. W. B. Crawford TREASURER.

NAME.	ATTENDANCES.					
	Com. Meetings.		Sub-Com. Meetings.		Total.	
	Actual.	Possible.	Actual.	Possible.	Actual.	Possible.
President ...	0	1				
Chairman of Council ...	0	1				
Chairman of Representative Meetings ...	0	1				
Treasurer ...	0	1				
} <i>ex-officio</i>						
Bailey, Dr. T. Ridley, Bilston ...	0	1				
Healey, Dr. J. J., Llanelly ...	1	1				
Lewys-Lloyd, Dr. E., Towyn ...	1	1				
McCrea, Dr. B. H. J., Bargoed ...	0	1				
Marks, Dr. L. Freeman, Mumbles ...	0	1				
Prytherch, Dr. J. R., Llangefni ...	0	1				
Thomas, Dr. W. E., Ystrad Rhondda ...	1	1				
Treasurer, Dr. W. B. Crawford, Cardiff ...	1	1				
Verity, Dr. R. J. S., Pontypool ...	0	1				

MINISTRY OF HEALTH COMMITTEE.

Chairman: Mr. E. P. Turner.

NAME.	ATTENDANCES.					
	Com. Meetings.		Sub-Com. Meetings.		Total.	
	Actual.	Possible.	Actual.	Possible.	Actual.	Possible.
President ...	1	7	1	1	2	8
Chairman of Council ...	7	7	1	1	8	8
Chairman of Representative Meetings ...	6	7	1	1	7	8
Treasurer ...	7	7	1	1	8	8
} <i>ex-officio</i>						
Badcock, Mr. J. H., London ...	3	7			3	7
Bailey, Dr. T. Ridley, Bilston ...	6	7	1	1	7	8
Bennett, Dr. N. G., London ...	0	7			0	7
Brackenbury, Dr. H. B., London ...	7	7	5	5	12	12
Buttar, Dr. C., London ...	6	7	3	4	9	11
Cardale, Dr. H. J., London ...	5	7	0	4	5	11
*Cates, Dr. H. J., St. Helens ...	4	5			4	5
Dain, Dr. H. G., Birmingham ...	7	7			7	7
Dawson, The Rt. Hon. Lord, G.C.V.O., K.C.M.G., C.B., London ...	2	7	1	1	3	8
Dill, Dr. J. F. Gordon, O.B.E., Hove ...	5	7	5	5	12	12
Domville, Dr. E. J., O.B.E., Bridport ...	5	7			5	7
Eccles, Mr. W. McAdam, London ...	2	7			2	7
Flemming, Dr. C. E. S., Bradford-on-Avon ...	6	7	4	4	10	11
Fothergill, Dr. E. R., Hove ...	7	7	4	4	11	11
Fry, Dr. P. V., East Moseley ...	4	7			4	7
Harman, Mr. N. Bishop, London ...	7	7	1	1	8	8
†Hill, Prof. A. Bostock, Birmingham ...	0	1			0	1
Hill, Dr. T. Eustace, O.B.E., Darlington ...	5	7			5	7
‡Houfton, Dr. E. H., Mansfield ...	2	3			2	3
Ivens, Dr. M. H. F., Liverpool ...	0	7			0	7
Jones, Dr. D. Roeyn, Newport ...	3	7			3	7
Jones, Dr. Hugh, Dolgelly ...	2	7			2	7
†Linnell, Dr. A., Towcester ...	1	1			1	1
*Lyster, Dr. R. A., Winchester ...	4	5			4	5
Macdonald, Dr. J. A., LL.D., Taunton ...	3	7			3	7
Maclean, Dr. E. J., Cardiff ...	4	7	1	1	5	8
§Morris, Sir Malcolm, London ...	1	4			1	4
Myles, Dr. G. T., Bristol ...	6	7			6	7
Shore, Dr. T. W., O.B.E., London ...	0	7			0	7
Thomas, Dr. W. E., Ystrad Rhondda ...	3	7			3	7
Turner, Mr. E. B., London ...	7	7	3	5	10	12
Verrall, Sir Jenner, LL.D., Harpenden ...	7	7	3	4	10	11
Williams, Dr. E. C. Pillman, London ...	3	7			3	7

* Appointed September, 1920. † Membership ceased July, 1920. ‡ Appointed January, 1921. § Resigned January, 1921.

SPECIAL COMMITTEE re FORMATION OF CENTRAL MEDICAL COMMITTEE.

Chairman: THE CHAIRMEN OF COUNCIL.

NAME.	ATTENDANCES.					
	Com. Meetings.		Sub-Com. Meetings.		Total.	
	Actual.	Possible.	Actual.	Possible.	Actual.	Possible.
President ...	0	2				
Chairman of Council ...	2	2				
Chairman of Representative Meetings ...	2	2				
Treasurer ...	2	2				
} <i>ex-officio</i>						
Macdonald, Dr. J. A., LL.D., Taunton ...	0	2				
Brackenbury, Dr. H. B., London ...	2	2				
Verrall, Sir Jenner, LL.D., Harpenden ...	2	2				

ANNUAL MEETING ARRANGEMENTS COMMITTEE.

Chairman. THE CHAIRMAN OF COUNCIL.

NAME.	ATTENDANCES.					
	Com. Meetings		Sub-Com. Meetings		Total.	
	Actual.	Possible.	Actual.	Possible.	Actual.	Possible.
President	0	2				
Chairman of Council ...	2	2				
Chairman of Representative Meetings	2	2				
Treasurer	2	2				
} <i>ex-officio</i>						
Dixon, Prof. W. E., O.B.E., F.R.S., Whittlesford	2	2				
Beattie, Prof. T., Newcastle-on-Tyne ...	2	2				
Don, Dr. James, Newcastle-on-Tyne ...	2	2				
Drummond, Dr. David, C.B.E., D.C.L., Newcastle-on-Tyne	2	2				
Elliot, Lt.-Col. R. H., I.M.S. (ret.), London	2	2				
Gaskell, Dr. J. F., Gt. Shelford	2	2				
Harman, Mr. N. Bishop, London	1	2				
Rolleston, Sir Humphry, K.C.B., London	2	2				
Rutter, Dr. H. L., M.B.E., Newcastle-on-Tyne	2	2				
Smith, Dr. J. W., Ryton on Tyne	2	2				
Snodgrass, Dr. W., Glasgow	2	2				
Willan, Mr. R. J., O.B.E., M.V.O., Newcastle-on-Tyne	2	2				

MEDICO-SOCIOLOGICAL COMMITTEE.

Chairman. DR. E. R. FOTHERGILL.

NAME.	ATTENDANCES.					
	Com. Meetings		Sub-Com. Meetings		Total.	
	Actual.	Possible.	Actual.	Possible.	Actual.	Possible.
President	0	4				
Chairman of Council ...	0	4				
Chairman of Representative Meetings	4	4				
Treasurer	2	4				
} <i>ex-officio</i>						
Bailey, Dr. T. Ridley, Bilston	4	4				
Brackenbury, Dr. H. B., London	3	4				
Farquharson, Dr. A. C., M.P., London ...	1	4				
Forbes, Dr. A., Sheffield	4	4				
Fothergill, Dr. E. R., Hove	4	4				
† Gordon, Mrs. Ogilvie, D.Sc., London ...	1	2				
Halford, Miss J., London	1	1				
Harman, Mr. N. Bishop, London	4	4				
Haydon, Miss O., London	1	1				
* Irving, Mrs. H. B., London	3	3				
* Kaye, Dr. J. R., Wakefield	2	3				
Mackenzie, Dr. S. Morton, Dorking ...	2	4				
† Parsons, Mrs. J. Kent, London	2	2				
* Pritchard, Dr. Eric, London	3	4				
Turner, Mr. E. B., London	4	4				

Co-opted February, 1921.
 † Co-opted March, 1921.

CONJOINT COMMITTEE OF B.M.A. AND SOCIETY OF M.O.S.H. AS TO MINIMUM SALARIES.

Chairman. THE CHAIRMAN OF REPRESENTATIVE MEETINGS.

NAME.	ATTENDANCES.					
	Com. Meetings		Sub-Com. Meetings		Total.	
	Actual.	Possible.	Actual.	Possible.	Actual.	Possible.
Chairman of Council	3	3				
Chairman of Representative Meetings ...	3	3				
Treasurer	3	3				
Turner, Mr. E. B., London	2	3				
Brackenbury, Dr. H. B., London	3	3				
Bailey, Dr. T. Ridley, Bilston	3	3				
Snell, Dr. E. H., Coventry	3	3				
Yerrall, Sir Jenner, LL.D., Harpenden ...	2	3				
Kenwood, Prof. J. R., C.M.G., London ...	0	2				
* Jones, Dr. Herbert, Hereford	2	2				
Buchan, Dr. G. F., London	2	2				
Joseph, Dr. G. W. N., Warrington	2	2				
Howarth, Dr. W. J., C.B.E., Longfield ...	2	2				
* Lyster, Dr. R. A., Winchester	2	2				
* Johnson, Dr. G. Pegrave, Stoke-on-Trent	2	2				
* Sanders, Dr. C., London	2	2				

* Representatives of Society of Medical Officers of Health.

Association Notices.

ELECTION OF COUNCIL OF ASSOCIATION, 1921-22.

A LIST of the Groups of Branches in the United Kingdom for election of twenty-four Members of the Council, 1921-22, and **Nomination Form**, were published in the SUPPLEMENT of March 12th (p. 73). The **Nominations** must be in the hands of the Medical Secretary **by May 16th**.

The result of the election for Members of Council by the Groups of the Oversea Branches was published in the SUPPLEMENT of February 19th, 1921.

SCHOLARSHIPS AND GRANTS IN AID OF SCIENTIFIC RESEARCH.

SCHOLARSHIPS.

The Council of the British Medical Association is prepared to receive applications for Research Scholarships as follows:

1. An ERNEST HART MEMORIAL SCHOLARSHIP, of the value of £200 per annum, for the study of some subject in the department of State Medicine.

2. THREE RESEARCH SCHOLARSHIPS, each of the value of £150 per annum, for research into some subject relating to the Causation, Prevention, or Treatment of Disease.

Each scholarship is tenable for one year, commencing on October 1st, 1921. A Scholar may be reappointed for not more than two additional terms.

The Conditions of the award of Scholarships are stated in the Regulations, a copy of which will be supplied on application to the Medical Secretary of the Association, 429, Strand, London, W.C.2.

GRANTS.

The Council of the British Medical Association is also prepared to receive applications for Grants for the assistance of Research into the Causation, Treatment, or Prevention of Disease. Preference will be given, other things being equal, to members of the medical profession, and to applicants who propose as subjects of investigation problems directly related to practical medicine.

The Conditions of the award of Grants are stated in the Regulations, a copy of which will be supplied on

application to the Medical Secretary of the Association, 429, Strand, London, W.C.2.

Applications.

Applications for Scholarships and Grants for the year 1921-22 must be made not later than Saturday, June 25th, 1921, in the prescribed form, a copy of which will be supplied by the Medical Secretary on application.

Each application should be accompanied by testimonials, including a recommendation from the head of the laboratory, if any, in which the applicant proposes to work, setting out the fitness of the candidate to conduct such work, and the probable value of the work to be undertaken. This is not intended, however, to prevent applications for Grants in aid of work which need not be performed in a recognized laboratory.

SIERRA LEONE BRANCH.

THE following change has been made by the Council, and takes effect on May 7th, 1921:

That a Sierra Leone Branch of the Association be formed, of area coterminous with the Colony and Protectorate of Sierra Leone.

Representation in Representative Body.—Under arrangements made by the Council the Branch will be entitled to independent representation in the Representative Body, 1921-22, to return one Representative.

BRANCH AND DIVISION MEETINGS TO BE HELD.

DORSET AND WEST HANTS BRANCH.—The annual meeting of the Dorset and West Hants Branch will be held at Yeovil on Wednesday, May 18th, at 3 o'clock, when the Presidential address, on "Experience of Two Recent Methods of Treatment," will be delivered by Dr. F. C. Bottomley, O.B.E. Luncheon will be served at 1.30 p.m. at the Three Choughs Hotel, the retiring President, Dr. Wetherall, in the chair. Dr. Norman Flower kindly invites members to tea after the meeting. A motor coach has been arranged to take members from the Bournemouth district, leaving The Square at 10.30 a.m. prompt. Applications for seats should be made early to Dr. Asten, Talbot Hill, Bournemouth.

METROPOLITAN COUNTIES BRANCH: SOUTH-WEST ESSEX DIVISION.—The annual meeting and dinner of the Division will be held on Thursday, May 19th.

METROPOLITAN COUNTIES BRANCH: WESTMINSTER DIVISION.—A general meeting of the Westminster Division (which includes Holborn) will be held on May 6th at 4.30 p.m. at the St. James's Vestry Hall, Piccadilly (next St. James's Church). Dr. G. E. Buchan will give an address on "National Health and the Practitioners," to be followed by a discussion. Officers will be elected for the coming year, and the names of gentlemen desirous of serving on the Executive Committee should be sent to the Honorary Secretary, Dr. F. D. Bennett, 18, Savile Row, W.1.

METROPOLITAN COUNTIES BRANCH: CAMBERWELL DIVISION.—The annual general meeting of the Division will be held at the Camberwell Infirmary on Friday, May 13th, at 3.30 p.m.

SOUTH MIDLAND BRANCH: BUCKINGHAMSHIRE DIVISION.—A meeting of the Buckinghamshire Division will be held on Wednesday, May 11th, at the Red Lion Hotel, High Wycombe, at 2.30 p.m. It is hoped that one of the Medical Secretaries of the Association will be present to explain the proposed scheme of federation with other bodies. Every member residing in the south part of Buckinghamshire is asked to attend and to bring a friend. Lunch can be obtained at the hotel. After the transaction of business the Chairman (Dr. Kennish) will introduce a discussion on influenza.

Meetings of Branches and Divisions.

YORKSHIRE BRANCH: LEEDS DIVISION.

Address by the Medical Secretary.

A MEETING of the Leeds Division, to which all members of the medical profession resident in Leeds and district were invited, was held in the Medical School, Leeds, on April 27th. An address was given by Dr. ALFRED COX, the Medical Secretary, on "The present demand for economy, and its effect on the medical profession."

Dr. Cox said that the various sections and interests in the medical profession must show an underlying unity, they must sink individualistic tendencies and hang together. They had more objects in common than differences. This difficulty of getting people to take an interest in their own business was not peculiar to the medical profession; politicians, lawyers,

teachers, miners, etc., were similarly situated. In all cases the few worked while the many grumbled—and reaped the benefits. In anticipating a favourable issue to the present economic difficulties the ordinary good sense of the Englishman could be relied on. For some time past all kinds of working men had got wages which often had little relation to the value of their work. In 1919-20 bonuses were given, the amount of which depended on the cost of living. In the reaction that followed, when we found we were spending more than we were earning, economists had made violent attacks on bonuses, the new Education Act, and other legislation for the millennium had been damped down, and so forth. There was a tendency for wages and salaries to fall, but organized working men intended to insist on a higher standard of living than they had before the war. By all means let a workman have a decent day's pay, but let him see to it that he gave a decent day's work in return. This applied to our profession also. The public thought that medical men put their patient's interest above every other consideration, and so medical men occupied a privileged position in public esteem. If, however, the public had reason to think that medical men were concerned entirely with how much money they could get for the minimum of exertion, the influence of the medical profession with the public would lessen, and its most valuable asset—its privileged position—would be lost or endangered. The demand for economy would affect the medical profession in that it tended to stop or delay the introduction of legislation of medical interest which involved expense. The new Minister of Health had already said that he should not spend money now on such things as could fairly be postponed, and that no big scheme of medical reform was at present to be expected. The economy campaign was likely to react on insurance practitioners in a demand for reduction of capitation fee, and as all rates of medical payments and private fees had gone up in response to the stimulus given by the rate paid for the work done under the Insurance Act, there was bound to be a reaction if the fee was reduced, and the reaction would affect the whole profession. Doctors who thought that because they were in private practice the rates paid for contract work did not concern them were gravely mistaken. Medical men required organization to be able to cope with any such reaction. Reductions could not be resisted if they were brought about with even-handed justice, but the medical profession, which was one of the last to raise its fees, must see that they only fell as other prices fell. A merely local organization was quite helpless; a national organization was necessary. The profession had no organization with prestige and influence with the public and the Government except the British Medical Association. In that great Association the Yorkshire Branch, which should be one of the leading branches, did not occupy the position that its size, importance, and opportunities should command; and the Leeds Division did not compare favourably in work and numbers with some other Divisions of the Yorkshire Branch. The medical profession in Leeds should, without delay, take steps for the better organization of their Division, and Dr. Cox hoped that the consultants would interest themselves in the matter. The Association had in the past owed much to the work of consultants for their colleagues in other forms of practice, and it needed them now.

After some discussion, in which reasons were given for the backward condition of the Leeds Division, a cordial vote of thanks was accorded to Dr. Cox for his address.

YORKSHIRE BRANCH: HUDDERSFIELD DIVISION.

A MEETING of the Huddersfield Division was held at the Huddersfield Royal Infirmary, on April 28th, to which all practitioners in the Division were invited. Dr. Cox, Medical Secretary, gave an address entitled "How much more State medical service does the medical profession want?" A lively discussion ensued, in which Drs. LAIRD, E. TROTTER, MCVIE, ORR, ROWTHORNE, TANSLEY, and HIRST took part. Criticism of the British Medical Association policy in relation to the Insurance Act was the principal line of the debate. Dr. COX made a spirited reply. On the motion of Dr. E. WALKER, seconded by Dr. IRVING, a vote of thanks to Dr. Cox was carried with acclamation. The meeting lasted three hours. Twenty-nine medical men were present and two joined the Association at the end of the meeting. The meeting was preceded by a dinner, at which Dr. Cox was the guest of the Executive of the Division.

METROPOLITAN COUNTIES BRANCH: HARROW DIVISION.

At a meeting of the Harrow Division held on April 26th the question of the British Medical Association becoming a federation was discussed. The Division were unanimous in welcoming such a proceeding, and the Representative to the Representative Meeting was directed to support the view that admission to membership of the proposed federation be open to all societies representing the medical profession and the medical profession only.

The position of Dr. Fothergill was also discussed, but the general opinion was that the steps already taken by the Council were thoroughly to be approved.

The Division proposed to ask one of the authorities to attend the next meeting of the Division in May, to explain at length the national provident scheme for hospital and additional medical services.

METROPOLITAN COUNTIES BRANCH: LEWISHAM DIVISION.

THE third meeting of the Lewisham Division was held on April 26th, at 45, Lawrie Park Road, Sydenham, S.E.26, with Dr. G. W. CHARLESLEY in the chair. It was agreed to defer discussion of the provident scheme for London hospitals until next meeting. Dr. White was appointed the Representative for Lewisham at the Representative Meeting. The Consultative Council's report was then fully discussed and the queries answered. The letter on the subject of municipal clinics from the Honorary Secretary of the Willesden Division was discussed, and the meeting expressed its agreement with the points raised. Drs. CHARLESLEY and GILCHRIST reported an interesting case of pyaemia in a child in which it was difficult to discover the site of origin of the infection. Dr. RICHARDSON showed pathological specimens of the case.

SUFFOLK BRANCH: WEST SUFFOLK DIVISION.

A MEETING of the West Suffolk Division was held at Bury St. Edmunds on April 26th, when Dr. F. R. BARWELL was in the chair.

THE CHAIRMAN introduced a discussion on the Report of the Council on the question of federation, and explained briefly the chief objects aimed at and the alterations in the constitution of the British Medical Association necessary to attain them. He emphasized the importance of deciding whether members wished the Association to offer federation to semi-medical bodies. After discussion it was resolved *nem. con.*, on the motion of Colonel FREEMAN, seconded by Dr. DOBIN, that the Division support the following resolution passed by the Edinburgh Branch, South-Eastern Counties Division:

That while this Division does not object to a federation of any bodies composed exclusively of medical practitioners, it objects to federation with bodies not consisting exclusively of registered medical persons.

THE SECRETARY explained the memorandum on collective opinion of the profession by Dr. Rowland Fothergill. After discussion it was resolved, on the motion of the SECRETARY, seconded by Dr. BENNETT:

That the Division request that Council should give serious consideration to this memorandum; and that the Council be informed that this Division considers a referendum, as suggested, desirable.

Dr. A. HOPE GOSSE gave an address on "The clinical diagnosis of cardiac arrhythmias unaided by graphic methods." This was much appreciated, and numerous questions were asked. Dr. Gosse subsequently demonstrated in the hospital wards the use of the polygraph. On the motion of the CHAIRMAN a very hearty vote of thanks was accorded to Dr. Gosse for his paper. The meeting then adjourned for tea, which was kindly provided by the Matron. During tea the result of the draw for the golf competition instituted by the Executive Committee was announced.

CAPE OF GOOD HOPE (WESTERN) BRANCH.

AT the first meeting for 1921 of the Cape of Good Hope (Western) Branch of the British Medical Association, held on March 18th, a very interesting and instructive address was delivered by the President, Dr. D. P. MARAIS, on the early diagnosis of tuberculosis. The lecturer dealt fully with the various signs and symptoms, their explanation and relative importance in the formation of a correct diagnosis.

MALAYA BRANCH: SINGAPORE DIVISION.

A MEETING of the Singapore Division was held on March 17th, when the VICE-PRESIDENT was in the chair.

THE SECRETARY read a communication from the Principal of the School of Medicine, from which it appeared that an inspection of the examinations of the King Edward VII Medical School had been held by the General Medical Council, to whom the examination papers were also submitted. The Registrar of the General Medical Council had notified the Principal that the papers had been submitted to examination experts, members of the Council and others, with the result that the examinations were considered satisfactory and sufficient.

The question of the annual general meeting of the Branch, which falls to be held this year in Penang, was raised, and the Secretary was instructed to communicate with the Secretary in Penang as to their wish to hold it there.

Dr. GALLOWAY read a paper on "The febrile phases of syphilis," and in the discussion which followed Drs. CLARKE, DAWSON, and VAN DORT took part.

INSURANCE.

LONDON INSURANCE COMMITTEE.

Women Practitioners and Male Insured Persons.

THE London Insurance Committee, on April 28th, passed a resolution expressing the view that in the case of a woman medical practitioner who limited her acceptances of insured persons to women patients, and was not prepared to have male insured persons assigned to her, Section 5 of the Distribution Scheme came into operation; this provides that if any practitioner is relieved of the liability to have insured persons assigned to him, the units credited to him for the purposes of the distribution of the Practitioners' Fund shall be reduced by

10 per cent. in the case of medical officers of institutions and by 7½ per cent. in the case of other practitioners. It appears that four medical women in London have restricted their acceptances to female insured persons; each of these women practitioners, on being notified of the course intended, has protested against any reduction of credits, maintaining that it is not unreasonable that a woman should decline to undertake the treatment of male patients.

Range of Medical Service.—The Committee at its previous meeting referred back a recommendation that it should not concur in the opinion expressed by the Local Medical Committee that an operation for the removal of haemorrhoids and an operation for the removal of cysts from the neighbourhood of the knee-joint were services which could not, consistently with the best interests of the patient, be properly undertaken by a general practitioner of ordinary professional competence and skill. The subcommittee which originally brought forward the recommendation now reported that it had taken the advice of its medical members and had decided to recommend concurrence with the Local Medical Committee's opinion. The Committee also agreed with a resolution which had been passed by the Wigan Insurance Committee, complaining of the "unbearable and expensive procedure necessary to decide definitely whether or not an operation came within the scope of medical benefit, and suggesting that every kind of medical treatment should be made available to insured persons under the National Insurance Acts.

Forms of Medical Record.—The Committee considered certain resolutions which had been passed by the Panel Committee, complaining of the present form of medical records. The Insurance Committee expressed its own view in resolutions that some form of medical records in connexion with treatment was necessary; that provision should be made in the records for all matters that were likely to be of clinical value in connexion with the case; and that no opinion should be expressed at present as to the existing form of medical records.

Sanatorium Benefit.—The sanatorium benefit as administered by the Committee terminated on May 1st, and the Sanatorium Benefit Subcommittee took occasion to submit a report reviewing the measures which during the Committee's period of responsibility have been undertaken for the treatment of tuberculous persons among the insured population. From 1912 to 1921 over 36,000 applications for sanatorium benefit have been dealt with, and treatment has been afforded to 29,000 tuberculous persons. Institutional treatment, mostly in sanatoriums, has been given to 25,000 persons. The Minister of Health has expressed his appreciation of the Committee's work in connexion with the treatment of tuberculosis.

LONDON PANEL COMMITTEE.

Hours of Practitioners and Pharmacists.

AT the meeting of the London Panel Committee, on April 26th, a report was presented of a conference which has lately been held between representatives of the Panel, Pharmaceutical and Insurance Committees with regard chiefly to the adequacy of the pharmaceutical service for dealing with "urgent" prescriptions. The conference agreed, after a long discussion, that prescriptions marked "Urgent" should be dispensed up to the hour of 9 p.m.; that, in order to render "urgent" prescriptions authentic they should be marked "Urgent" and initialed by the doctor, who would also indicate the time of issue and endorse with the signature of the pharmacist, together with the time when dispensed. The position of the Pharmaceutical Committee was that the difficulty was caused or aggravated by the fact that the closing hour for pharmacists and the closing hour at the surgeries did not coincide, and that the situation would be relieved if those practitioners who sat until a late hour could be induced to bring their hours forward. The objection to earlier hours, particularly in industrial districts, was pointed out, but it was agreed that the Panel Committee should make inquiries of practitioners as to the practicability, consistently with the best interests of patients, of advancing the hours of consultation. Questions are also to be asked of the practitioners as to the adequacy of the pharmaceutical service in their districts, and these inquiries are now proceeding.

Naval and Military Appointments.

ROYAL NAVAL MEDICAL SERVICE.

THE following notifications are announced by the Admiralty: Surgeon Commanders: H. Huskinson, W. S. H. Sequeira, S. F. Dudley, O.B.E., and S. Roach to the *President* additional for three months' hospital course. H. W. B. Shewell, O.B.E., to the *Revenge* as Squadron Medical Officer. W. W. Keir, C.M.G., to the *Teiud* additional for Plymouth Hospital (temporary). A. H. S. Richardson to R.N. Hospital, Haslar. Surgeon Lieut. Commanders: M. S. Moore to the *President* additional for three months' hospital course. H. R. B. Hull to the *Vivid* additional for Plymouth Hospital (temporary). Surgeon Lieutenants promoted to the rank of Surgeon Lieutenant Commander: J. C. Sinclair, H. L. P. Peregrino.

ARMY MEDICAL SERVICE.

ROYAL ARMY MEDICAL CORPS.

To be Captains: Temporary Captain G. J. McGarty, M.C., with seniority April 19th, 1917, and precedence next below J. F. W. Moenan. Lieutenants (Temporary Captains) A. R. Bayliss, E. N. P. Martland. E. C. Pawcett, late temporary Captain, to be temporary Captain, with seniority, December 21st, 1916.

The following officers re-inquire their commissions: Temporary Major R. A. Beaver and retains the rank of Major. Temporary Captains and retain the rank of Captain: W. D. Perry (on account of ill health contracted on active service), J. Joule, W. Spilker, G. Fleming, E. Bryceon, H. R. McNair. Temporary Lieutenants and retain the rank of Lieutenant: S. E. Price, W. A. Byro (on account of ill health).

ROYAL AIR FORCE.

MEDICAL BRANCH.

The following are granted temporary commissions as Flight Lieutenants with effect from and with seniority of the dates indicated: R. J. Monahan (April 11th), J. Craig (April 25th).

OVERSEAS FORCES.

SOUTH AFRICAN MEDICAL CORPS.

Temporary Captain G. S. Coghlan, M.B.E., relinquishes his commission on completion of service, July 12th, 1920, and retains the rank of Captain.

Temporary Colonel P. G. Stock, C.B. (Colonel S.A.M.C.), relinquishes his temporary commission April 17th, 1919, and retains the rank of Colonel (substituted for notification in the *London Gazette*, May 27th, 1919).

TERRITORIAL FORCE.

ROYAL ARMY MEDICAL CORPS.

Lieut.-Colonel A. H. Vernon, T.D., to command 3rd Southern Casualty Clearing Station.

Captain (acting Major) E. Osborne relinquishes the acting rank of Major on ceasing to be specially employed.

To be Captains: Captain J. McKay, M.C. (late R.A.M.C., S.R.), with precedence as from January 24th, 1916; Captain F. D. Marsh, M.C., from 1st Southern General Hospital, with precedence as from August 25th, 1914.

D. J. Davies to be Lieutenant.

DEFENCE FORCE.

ARMY MEDICAL SERVICE.

R.A.M.C.—To be temporary Majors: J. A. Clark, L. R. Colledge, B. Addensbrooke, C. B. Baxler, O.B.E., T.D., S. J. C. Holden. To be temporary Captains: E. Coplans, T. P. Cole, C. H. Carlton, M.C., G. P. Hardy, M.C., E. Scott, D.S.O., F. J. Morris, J. Grant-Morrin, O. H. Mavor, J. A. Stephouse, H. L. Garson, O.B.E., M.C., A. Walker, D.S.O., H. K. Ward, A. Morris, C. H. Comerford, B. E. A. Batt, H. Wilson, M.C., W. Tresswain. To be temporary Lieutenants: O. G. Misquith, C. S. Atkin, A. Fisher.

1st East Anglian Field Ambulance.—To be temporary Lieutenant-Colonel: H. F. Everitt. To be temporary Captains: W. J. Rice, H. V. Walsh, C. S. Stadden, W. S. Forbes.

3rd (Home Counties) Field Ambulance (D.F.).—To be temporary Lieutenant-Colonel: H. G. G. Mackenzie, D.S.O.

4th London Field Ambulance (D.F.).—To be temporary Lieutenant: C. C. Coghlan.

5th London Field Ambulance (D.F.).—To be temporary Major: D. T. H. Lea.

6th London Field Ambulance (D.F.).—To be temporary Captains: J. Rowland, M.C., J. O. Thomas. To be temporary Lieutenant: J. Sannell.

1st South Midland Field Ambulance.—To be temporary Lieutenant-Colonel: W. Stobie, O.B.E.

2nd (Wessex) Field Ambulance (D.F.).—To be temporary Lieutenant-Colonel: C. M. Kennedy, M.B.E.

3rd (Wessex) Field Ambulance (D.F.).—To be temporary Lieutenant-Colonel: E. Alderson.

Sanitary Section.—To be temporary Captain: G. T. Stewart, West Riding Field Ambulance (D.F.).—To be temporary Lieut.-Colonels: J. Mackinnon, D.S.O., F. Whalley, D.S.O., W. Lister.

2nd (West Riding) Field Ambulance (D.F.).—To be temporary Major: T. R. Kenworthy. To be temporary Captain: D. F. Dobson.

3rd (West Riding) Field Ambulance (D.F.).—To be temporary Major: E. F. Skinner. To be temporary Captains: R. A. Stark, M.C., W. T. D. Mart, R. E. Pleasance.

3rd (West Lancashire) Field Ambulance (D.F.).—To be temporary Major: A. J. D. Riddett.

DIARY OF SOCIETIES AND LECTURES.

ROYAL SOCIETY OF MEDICINE.—War Section: Mon., 5.30 p.m., Annual General Meeting; Surgeon-Commander S. F. Dudley, R.N.; The Influenza Epidemic as it Affected the Royal Navy. Section of Psychiatry: Tues., 5.30 p.m., Annual General Meeting. Section of Surgery, Subsection of Proctology: Wed., 5.30 p.m., Annual General Meeting; Informal discussion, to be introduced by the President. Section of Neurology: Thurs., 8.30 p.m., Annual General Meeting; Professor Marinisco (Bukarest); Encephalitis Leborgia (communicated by Sir Frederick Mott). Clinical Section: Fri., 5.30 p.m., Annual General Meeting. Section of Ophthalmology: Fri., 8 p.m., Exhibits: 8.30 p.m., Dr. D. Leighton Davies; Lacrymal Obstruction, Results of Anatomical Method of Treatment (Toti); Mr. Ernest Clarke; Lessons from Forty Years of Refraction Work; Miss J. C. Mann; Aphakia in a Human Embryo of Five or Six Weeks.

HARVEIAN SOCIETY OF LONDON, Paddington Infirmary, Harrow Road, W.—Thurs., 4.30 p.m.: Clinical Meeting.

INSTITUTE OF PATHOLOGY AND RESEARCH, St. Mary's Hospital, Paddington, W.—Thurs., 4.30 p.m., Sir James Mackenzie, F.R.S.: The Opportunities of the General Practitioner as Essential for the Investigation of Disease and the Progress of Medicine.

POST-GRADUATE COURSES AND LECTURES.

WEST LONDON POST-GRADUATE COLLEGE, Hammersmith, W.—Daily, 10 a.m., Ward Visits; 2 p.m., In- and Out-patient Clinics and Operations. Demonstrations: Mon., 12.15 p.m., Dr. Burnford; Pathological, Tues., 12 noon, Mr. Gray; Fractures; Wed., 12 noon, Mr. Sinclair; Surgical Diseases of the Abdomen; Thurs., 10.30 a.m., Dr. Shinson; Gynaecological; Fri., 10 a.m., Dr. Stewart; Neurological; Sat., 10 a.m., Dr. Saunders; Medical Diseases of Children. Lectures: 5 p.m., Mr. Harman, Mon.: Education of

Children with Defective Vision; Tues.: Blind and Partly Blind Children; Wed., Dr. Owen; Nephritis; Thurs., Dr. E. S. Reynolds; Vascular Lesions of the Brain; Fri., Dr. Snowden: Psychological Analysis.

GLASGOW POST-GRADUATE MEDICAL ASSOCIATION, Eye Infirmary.—Wed., 4.15 p.m., Eye Cases.

LONDON HOSPITAL MEDICAL COLLEGE.—Mon., 5 p.m., Dr. W. M. Feldman: Ante-natal and Post-natal Child Physiology; Tues. and Fri., 5.15 p.m., Dr. M. Culpin: Psycho-neuroses.

LONDON LOCK HOSPITAL, Dean Street, W.—Tues., 2.30 p.m., Mr. McDonagh: Microscopic Demonstration of *Leucocytozoon sphyllidis*.

MANCHESTER ROYAL INFIRMARY.—Thurs., 4.30 p.m., Dr. G. R. Murray: Diseases of the Endocrine Glands.

NATIONAL HOSPITAL FOR THE PARALYSED AND EPILEPTIC, Queen Square, W.C.—Mon., Tues., Thurs., and Fri., 2 p.m.: Out-patient Clinics. Lectures: 3.30 p.m., Mon., Dr. Saunders; Pituitary Disorders; Tues., Dr. James Taylor; Epilepsy; Thurs., Dr. Tooth: Disseminated Sclerosis; Fri., Dr. Collier: Aphasia.

British Medical Association.

OFFICES AND LIBRARY, 49, STRAND, LONDON, W.C.2.

Reference and Lending Library.

THE READING ROOM, in which books of reference, periodicals, and standard works can be consulted, is open to members from 10 a.m. to 6.30 p.m., Saturdays 10 to 2.

LENDING LIBRARY: Members are entitled to borrow books, including current medical works; they will be forwarded, if desired, on application to the Librarian, accompanied by 1s. for each volume for postage and packing.

Departments.

SUBSCRIPTIONS AND ADVERTISEMENTS (Financial Secretary and Business Manager. Telegrams: Articulate, Westrand, London). MEDICAL SECRETARY (Telegrams: Medisecra, Westrand, London). EDITOR, *British Medical Journal* (Telegrams: Aitiology, Westrand, London). Telephone number for all Departments: Gerrard 2630 (3 lines).

SCOTTISH MEDICAL SECRETARY: 6, Rutland Square, Edinburgh. (Telegrams: Associate, Edinburgh. Tel.: 4351 Central.) IRISH MEDICAL SECRETARY: 16, South Frederick Street, Dublin. (Telegrams: Bacillus, Dublin. Tel.: 4757 Dublin.)

Diary of the Association.

MAY.

- 6 Fri. London: Westminster Division, St. James's Vestry Hall, Piccadilly, 4.30 p.m.
11 Wed. Buckinghamshire Division, Red Lion Hotel, High Wycombe, 2.30.
13 Fri. London: Medico-Sociological Committee, 2.30 p.m., Camberwell Division: Annual General Meeting, Camberwell Infirmary, 3.30 p.m.
14 Wed. Dorset and West Hants Branch, Annual Meeting, Yeovil, 3 p.m.; Luncheon, 1.30 p.m.
19 Thurs. South-West Essex Division: Annual Meeting and Dinner.
26 Thurs. London: Insurance Acts Committee, 2.30 p.m.

APPOINTMENTS.

HINSCHE, Charles T. W., M.R.C.S., L.R.C.P., Honorary Anaesthetist, West End Hospital for Nervous Diseases.
MORGAN, M. Travers, M.B., Ch.B. Liverp., D.P.H., Medical Officer to the Board of Education.
RICHARDSON, G. B., F.R.C.S., Resident Surgical Officer to Ancoats Hospital, Manchester.

BIRTHS, MARRIAGES, AND DEATHS.

The charge for inserting announcements of Births, Marriages, and Deaths is 9s., which sum should be forwarded with this notice not later than the first post on Tuesday morning, in order to ensure insertion in the current issue.

BIRTHS.

PICKERING.—On April 22nd, at 38, St. George's Place, Bolton, Lancs. to the wife of Bernard Pickering, M.B., Ch.B. Edin., a daughter (stillborn).
TULLIS.—On April 22nd, 1921, the wife of G. Donaldson Tullis, M.B., Ch.B., Whitecross, Hereford, of a daughter.
WELLS.—On April 24th, at 226, Mitcham Road, S.W.17, the wife of Arthur W. Wells, M.R.C.S., L.R.C.P., a son.

MARRIAGE.

PARKES WEBER—UNGER-LAISSLE.—On March 17th, Dr. Frederick Parkes Weber to Hedwig Unger-Laissle, M.D.

DEATH.

Row.—Narsing Row, M.B., B.S. Madras, M.R.C.S. Eng., L.R.C.P. Lond., on April 10th, 1921, after a brief and sudden attack of bronchopneumonia, at his residence, Pceerhoy Mansions, Sandhurst Road, Girgaum, Bombay, deeply mourned by his sorrowing brothers, sister, and a large circle of relations and friends.

SUPPLEMENT

TO THE

BRITISH MEDICAL JOURNAL.

LONDON: SATURDAY, MAY 14TH, 1921.

CONTENTS.

BRITISH MEDICAL ASSOCIATION.	PAGE		PAGE
ANNUAL REPRESENTATIVE MEETING AT NEW-CASTLE: Provisional Agenda	181	MEETINGS OF BRANCHES AND DIVISIONS	185
PROCEEDINGS OF COUNCIL	184	NATIONAL HEALTH AND THE PRACTITIONER. MEETING OF THE WESTMINSTER AND HOLBORN DIVISIONS	186
CURRENT NOTES:		CORRESPONDENCE:	
MILEAGE RETURNS, 1921	184	ANAESTHETISTS' FEES IN INSURANCE PRACTICE	187
HINTS FOR INSURANCE PRACTITIONERS	184	NAVAL AND MILITARY APPOINTMENTS... ..	187
FEES TO SCOTTISH PRACTITIONERS CALLED IN BY MIDWIVES	185	DIARY OF SOCIETIES AND LECTURES	188
ASSOCIATION NOTICES:		ASSOCIATION INTELLIGENCE	188
REPRESENTATIVE MEETING, 1921... ..	185	APPOINTMENTS... ..	188
ELECTION OF COUNCIL... ..	185	BIRTHS, MARRIAGES, AND DEATHS	188
BRANCH AND DIVISION MEETINGS TO BE HELD	185		

SPECIAL NOTICE TO MEMBERS.

As the following Motions will require to be dealt with by early meetings of the Divisions, together with the Annual Report of the Council, which was printed in the "Supplement" of April 30th, this "Supplement" should be carefully preserved and taken to the Division meeting.

MATTERS REFERRED TO DIVISIONS.

British Medical Association.

ANNUAL REPRESENTATIVE MEETING, NEWCASTLE, 1921.

The Annual Representative Meeting of the Association will be held in King's Hall, Armstrong College, Newcastle-on-Tyne, on Friday, July 15th, 1921, and following days as may be necessary.

PROVISIONAL AGENDA.

[NOTE.—This Provisional Agenda gives only those Recommendations of the Council contained in the Annual Report to which Amendments or Riders have been sent in; also any independent Motions from Divisions.]

EXCLUSION OF LAY PRESS FROM MEETING.

1. Motion by MID-CHESHIRE DIVISION:

That the Representative Body is of opinion that the lay press should be excluded from the Annual Representative Meeting, but that a *précis* of the proceedings should be supplied to them for publication.

COMPOSITION OF COUNCIL.

2. Motion: That the following recommendation of Council (SUPPLEMENT, April 30th, 1921, p. 115, para. 92) be adopted:

That it be an instruction to the Council to take steps for amendment of By-law 46 (and other By-laws consequentially) by substituting for existing By-law 46 (c) and (d) a paragraph somewhat as follows:

(c) 16 by the Representatives of Constituencies present at the Annual Representative Meeting, namely, 12 by the Representatives (acting together) of the Constituencies in England; 1 by the Representatives (acting together) of the Constituencies

in Ireland; 2 by the Representatives (acting together) of the Constituencies in Scotland; and 1 by the Representatives (acting together) of the Constituencies in Wales; existing By-law 46 (e) to become 46 (d).

Representation of Wales on Council.

3. Amendment by NORTH GLAMORGAN AND BRECKNOCK DIVISION:

That Wales should be represented on the Council by two representatives (one for North and one for South Wales) from grouped Divisions situate in Wales.

COMPOSITION OF INSURANCE ACTS COMMITTEE.

4. Motion by ISLE OF ELY DIVISION:

That the co-opted and *ex officio* members of the Insurance Acts Committee of the Association should not exceed one-fifth of the total number of the Committee.

QUESTION OF AFFILIATION FOR NON-MEDICAL BODIES.

[NOTE.—Particular attention is drawn to para. 123 of the Annual Report of Council, in which it is stated that the Council is of opinion that it would be inadvisable to affiliate to the British Medical Association at the present time any bodies whose ordinary membership is open to other than members of the medical profession.]

5. Amendment by GLASGOW EASTERN DIVISION:

That the principle of federation be agreed to, but confined to bodies limiting their membership to medical men.

6. Amendment by LEICESTERSHIRE AND RUTLAND DIVISION:

(i) That the words "or any allied science," and "or any allied profession" in new Article 6 (b) (SUPPLEMENT, March 5th, 1921, p. 57, para. 6) be omitted; and (ii) that the words "or any allied science" and "or any allied profession" in new Article 7 (b) (SUPPLEMENT, March 5th, 1921, p. 57, para. 7) be omitted.

7. Amendment by NORTH SUFFOLK DIVISION:

That the British Medical Association should become a federation of medical bodies alone.

8. Amendment by MID-CHESHIRE DIVISION :

That the Representative Body disapproves of any attempt to procure federation or affiliation between the British Medical Association and any non-medical body.

9. Amendment by SOUTH-EASTERN COUNTIES (EDINBURGH) DIVISION :

That while this meeting does not object to a federation of any bodies composed exclusively of medical practitioners, it objects to federation with bodies not consisting exclusively of registered medical practitioners.

10. Amendment by REIGATE DIVISION :

That, as regards the present policy of the Association, Minute 44 of the Annual Representative Meeting, 1920, in so far as that Minute contemplated that there might possibly be admitted to affiliation any body or bodies other than a purely medical body or bodies representing substantially an ex-Branch or group of ex-Branches of the Association outside Great Britain, be rescinded.

11. Amendment by REIGATE DIVISION :

That in draft Articles 6 (b) and 7 (b) (SUPPLEMENT, March 5th, 1921, page 57) the words "or any allied," both in lines 2 and 3 in each case, be omitted.

12. Amendment by REIGATE DIVISION :

That draft Article 6, as to corporate members (SUPPLEMENT, March 5th, 1921, page 57) be amended to read as follows :

Corporate Members.

The following corporate bodies shall be entitled to be corporate members of the Association—namely, any association or body of persons which

(a) contains among its ordinary members no other persons than such as are eligible as ordinary members of the Association ;

(b) in the opinion of the Representative Body represents substantially, either as regards membership or area, at the time of its application for corporate membership of the Association, a former Branch or group of former Branches of the Association outside Great Britain ;

(c) is incorporated under the laws of any part of the British Empire other than Great Britain ;

(d) has for one of its objects the promotion of medical science or of the welfare of the medical profession ; and

(e) is approved as a corporate member by the Representative Body hereinafter mentioned.

13. Amendment by REIGATE DIVISION :

That draft Article 7, as to nominated members (SUPPLEMENT, March 5th, 1921, page 57), be amended to read as follows :

Nominated Members.

7. A nominated member of the Association shall be an individual nominated for that purpose by any unincorporated association or body of persons which

(a) contains among its ordinary members no other persons than such as are eligible as ordinary members of the Association ;

(b) in the opinion of the Representative Body represents substantially, either as regards membership or area, at the time of its application for approval by the Representative Body for the purpose of making such nomination, a former Branch or group of former Branches of the Association outside Great Britain ;

(c) has been formed within any part of the British Empire other than Great Britain ;

(d) has for one of its objects the promotion of medical science or of the welfare of the medical profession ; and

(e) is approved by the Representative Body for the purpose of making such nomination ; any such association or body is hereinafter referred to as a "nominating body."

14. Amendment by REIGATE DIVISION :

That the Rules or Memoranda of the Representative Body as to possible affiliating arrangements be worded in accordance with the foregoing resolutions.

15. Amendment by EDINBURGH AND LEITH DIVISION :

That as regards the present policy of the Association, Minute 44 of the Annual Representative Meeting, 1920, in so far as that Minute contemplated that there might possibly be admitted to affiliation with the Association any body or bodies other than a purely medical body or bodies, be rescinded.

16. Amendment by EDINBURGH AND LEITH DIVISION :

That draft Article 6, as to possible corporate members of the Association (SUPPLEMENT, March 5th, 1921, page 57) be amended :

(i) By insertion of the following new sub-para. (a) :

(a) Contains among its ordinary members no other persons than such as are eligible as ordinary members of the Association ;

(ii) By omitting, in the second and third lines respectively of present sub-para. (b), the words "or any allied."

(iii) By renumbering sub-paras. (a)-(c) to be (b)-(d) accordingly.

17. Amendment by EDINBURGH AND LEITH DIVISION :

That draft Article 7, as to possible nominated members of the Association (SUPPLEMENT, March 5th, 1921, p. 57) be amended :

(i) By insertion of the following new sub-para. (a) :

(a) Contains among its ordinary members no other persons than such as are eligible as ordinary members of the Association ;

(ii) By omitting, in the second and third lines respectively of present sub-para. (b), the words "or any allied."

(iii) By renumbering sub-paras. (a)-(c) to be (b)-(d) accordingly.

18. Amendment by EDINBURGH AND LEITH DIVISION :

That any necessary alterations consequential on the foregoing be made in the draft Articles and By-laws as to federation facilities (SUPPLEMENT, March 5th, 1921, pages 56-63).

19. Amendment by EDINBURGH AND LEITH DIVISION :

That the Rules or Memoranda of the Representative Body as to possible affiliating arrangements be worded in accordance with the foregoing resolutions.

SUBSCRIPTION.

*Alternative form of By-law as to Subscription.
(To be considered if "federation" is adopted by the
Representative Body.)*

20. Motion : That the following Recommendation of the Council (SUPPLEMENT, April 30th, 1921, p. 120, para. 134) be adopted :

That the Annual Representative Meeting, 1921, adopt as a By-law of the Association the following amended form of draft By-law 12 contained in the Appendix to the Report of the Council as to the question of steps whereby the Association may become in part a federation (BRITISH MEDICAL JOURNAL SUPPLEMENT, March 5th, 1921, page 60) :

By-law 12.—(1) On and after January 1st, 1922, the annual subscription to the Association shall be as follows :

A. As to Ordinary Members resident in any part of the United Kingdom—

(i) For a member of not less than ten years' standing who has definitely and permanently retired from the active practice of the medical profession and has signed and transmitted to the Treasurer a declaration to that effect—Two Guineas.

(ii) For any member of not less than forty years' standing—Two Guineas.

(iii) For a member admitted to membership before the expiration of two years from the date of his registration under the Medical Acts—One Guinea and a Half, until December 31st next occurring after the expiration of four years from the date of such registration.

(iv) For two members being a husband and his wife residing together—Four Guineas and a Half.

(v) Except as otherwise herein provided—Three Guineas.

B. As to Ordinary Members resident Outside the United Kingdom—

(i) For any officer of the Royal Navy Medical Service, the Royal Air Force Medical Service, the Army Medical Service, or the Indian Medical Service—Two Guineas.

(ii) For any other member—One Guinea and a Half.

C. As to Corporate Members and Nominated Members—

Such sum whether by way of capitation or otherwise as the Representative Body may fix in each particular case.

Provided that any member of any class (and in the case of an ordinary member wherever resident) admitted on or after July 1st in any year shall pay only half the current subscription for that year.

(2) For the purposes of this By-law an ordinary member shall be deemed to reside in that place in which his ordinary place of abode is situate at the time at which, according to the Regulations, his subscription is considered due.

ANNUAL SUBSCRIPTION OF MEMBERS IN AUSTRALIA.**21. Amendment by NEW SOUTH WALES DIVISION-BRANCH:**

That the annual subscription of members in Australia be £1 10s. instead of £2 2s. as at present; and that By-law 11 (1) (b) (By-law 12 (i) (B) (ii) under "Federation") be amended accordingly.

QUESTION OF NON-MEMBERS BEING ELIGIBLE FOR MEMBERSHIP OF BRANCH COUNCILS AND DIVISION EXECUTIVE COMMITTEES.**22. Amendment by the COUNCIL:**

That existing By-law 16 (to be By-law 17) (SUPPLEMENT, March 5th, 1921, page 61) be amended by substituting, in line 3, and last line but one, after the word "Members," the words "of the Association."

23. Amendment by the COUNCIL:

That existing By-law 19 (to be By-law 20) (SUPPLEMENT, March 5th, 1921, page 61) be amended by substituting, in line 4 and last line but one, after the word "Members," the words "of the Association."

DIVISIONS TO BE NOTIFIED OF CANDIDATES FOR MEMBERSHIP OF BRITISH MEDICAL ASSOCIATION.**24. Motion by GATESHEAD DIVISION:**

That the names of candidates for membership of the British Medical Association should be brought before the Division in which they reside.

STUDENT CLASS OF MEMBERSHIP OF BRITISH MEDICAL ASSOCIATION.**25. Motion by GATESHEAD DIVISION:**

That, in order to stimulate the interest of senior students of medicine in the work of the British Medical Association, and so tend to secure their adherence at the outset of their careers as practitioners, the British Medical Association institute a *student class* of members at a reduced fee, with the privilege of attending scientific meetings and receiving a free copy of the JOURNAL weekly.

BASIS OF REPRESENTATION IN REPRESENTATIVE BODY.**26. Motion by LEICESTERSHIRE AND RUTLAND DIVISION:**

That Representation at the Annual Representative Meeting be based on the number of members of the Division on December 31st preceding the Annual Representative Meeting.

METHOD OF ELECTION OF MINISTRY OF HEALTH COMMITTEE.**27. Motion by GUILDFORD DIVISION:**

That the Representative Body is of the opinion that the present method of election of the members of the Ministry of Health Committee is unsatisfactory, in view of the great importance to the profession of the work entrusted to that Committee, and accordingly instructs the Council to take immediate steps to convert the Ministry of Health Committee into a Standing Committee elected in the same manner as the Medico-Political Committee.

[NOTE.—The Ministry of Health Committee is at present an *ad hoc* Committee appointed each year by the Council. For its membership see SUPPLEMENT, May 7th, 1921, p. 176.]

PROPOSED CENTRAL MEDICAL COMMITTEE.

28. Motion: That the Annual Report of Council under "Proposed Central Medical Committee representative of the profession as a whole to consult with the Minister of Health on questions of policy affecting the profession" (SUPPLEMENT, April 30th, 1921, pp. 123-4, paras. 167-177), be approved.

29. Motion by PORTSMOUTH DIVISION:

That the Representative Body is of opinion that the collective opinion of the medical profession can be adequately and truly expressed to the Minister of Health only through a body elected directly by the profession for that purpose, such body to have the power, if thought advisable, to co-opt for any special purpose representatives of the medical profession not exceeding one-third of the total number of the committee.

30. Rider by PORTSMOUTH DIVISION:

That this election should be organized and conducted by the British Medical Association.

WHOLE-TIME PUBLIC MEDICAL OFFICERS AND PRIVATE PRACTICE.**31. Motion by PORTSMOUTH DIVISION:**

That the Representative Body is of opinion that medical men practising as whole-time officials of public authorities should be precluded from practice for private reward in the same district (i) while holding their appointments; and (ii) for a period of five years subsequently, except with the consent of the local medical profession.

MOTOR CAR LICENCES.**32. Motion by BUCKINGHAMSHIRE DIVISION:**

That in the event of a medical man having two cars, only one being used at a time, the licence for the second car should be halved.

FEES AND TRAVELLING ALLOWANCES OF MEDICAL WITNESSES.**33. Motion by BUCKINGHAMSHIRE DIVISION:**

That an adequate travelling allowance be paid in connexion with attendance at a coroner's court, and that the fee for giving evidence should be two guineas, and for a necropsy three guineas, also that these fees should apply to the staffs of hospitals.

FEE FOR NOTIFICATION OF INFECTIOUS DISEASES.**34. Motion by NORTH GLAMORGAN AND BRECKNOCK DIVISION:**

That the Representative Body instruct the Council to press for the restoration of the 2s. 6d. notification fee forthwith and without further delay.

FEDERATION OF MEDICAL AND ALLIED SOCIETIES.**35. Motion by GLOUCESTERSHIRE DIVISION-BRANCH:**

That the Representative Body is of the opinion that the Association should agree to appoint accredited representatives to the Federation of Medical and Allied Societies.

INSURANCE RECORD CARDS.**36. Motion by MID-CHESHIRE DIVISION:**

That the Representative Body considers the insurance record cards are unnecessarily irksome and impracticable, and that the scheme by Dr. Locket, as published in the BRITISH MEDICAL JOURNAL SUPPLEMENT of February 19th, 1921, be considered by the meeting.

SUPPLEMENTARY REPORT OF COUNCIL.

[Note.—The Supplementary Report of Council will be published in the SUPPLEMENT of July 2nd, 1921.]

LIBRARY OF THE BRITISH MEDICAL ASSOCIATION.

A list of periodical publications, official reports, and Blue Books in the Library of the British Medical Association available for issue to members on loan has been printed, and copies can be obtained free on application to the Librarian at the house of the Association, 429, Strand, W.C. The regulations governing the loan of these publications are stated in the introduction to the list. The Library is open for consultation from 10 a.m. till 6.30 p.m. (on Saturdays 10 a.m. till 2 p.m.).

British Medical Association.

PROCEEDINGS OF COUNCIL.

A MEETING of the Council was held at 429, Strand, London, W.C., on Wednesday, April 20th, and Thursday, April 21st, 1921, with Dr. R. A. BOLAM in the chair. There were present:

Sir Clifford Allbutt (President), Dr. T. W. H. Garstang (Chairman of Representative Meetings), Dr. G. E. Haslip (Treasurer), Dr. T. Ridley Bayley (Bilston), Dr. J. A. P. Barnes (London), Dr. J. W. Bone (Luton), Dr. H. B. Brackenbury (London), Dr. James Don (Newcastle), Dr. R. Langdon Down (Hampton Wick), Mr. W. MeAdam Eccles (London), Lieut.-Col. R. H. Elliot, I.M.S.(ret.), Dr. D. Ewart (Chester), Dr. A. C. Farquharson, M.P. (London), Dr. A. Forbes (Sheffield), Dr. E. R. Fothergill (Ilave), Dr. J. Giusani (Cork), Dr. J. Goff (Windsorham), Mr. N. Bishop Harman (London), Dr. D. Lawson (Banchoy), Sir R. H. Luce (Derby), Dr. J. A. Macdonald (Taunton), Dr. S. Morton Mackenzie (Dorking), Major-General Sir William Macpherson, A.M.S. (ret.) (London), Dr. H. C. Maetier (Wolverhampton), Dr. R. Peasecke (Dublin), Dr. C. M. Pearson (Edinburgh), Dr. F. Radcliffe (Oldham), Dr. C. E. Robertson (Glasgow), Dr. D. Ross (London), Dr. D. A. Sheahan (Portsmouth), Dr. W. Johnson Smyth (Bournemouth), Dr. W. Snodgrass (Glasgow), Dr. F. O. Stedman (Weybridge), Dr. J. Stevens (Edinburgh), Dr. W. B. Crawford Treasure (Cardiff), Mr. E. B. Turner (London), Dr. E. O. Turner (Great Missenden), Sir Jenner Verrall (Harpden).

On the nomination of various groups of Branches outside the United Kingdom Dr. T. P. Dunhill, C.M.G., Dr. Oswald Marriott, and Dr. W. F. Law, were elected members of the Council for the year 1921-22 for the Australian, Chinese, and West Indian groups respectively.

Annual Meetings.

A request by the Medical Committee of the Church Missionary Society for permission to hold a medical missionary meeting during the Annual Meeting at Newcastle-upon-Tyne in July, 1921, was granted subject to the date being convenient to the local executive. Permission was granted to the Council of the Irish Medical Schools' and Graduates' Association to hold its usual luncheon during the Newcastle meeting, and to the National Temperance League to hold its usual breakfast.

Invitations to hold the Annual Meeting in 1924 have been received from Bath, Bradford, and Nottingham. The Council decided to leave the choice over until the October meeting of the new Council. The Annual Meeting will be held at Glasgow in 1922, and at Portsmouth in 1923.

Award of Gold Medal.

On the proposal of the Chairman of Council (Dr. BOLAM), Sir JAMES BARR, Sir JENNER VERRALL, and Dr. J. A. MACDONALD, seconded by Dr. E. O. TURNER, it was resolved that the Gold Medal of the Association be presented to Sir Dawson Williams, C.B.E., M.D., D.Sc., F.R.C.P., for his distinguished services to the Association and the medical profession as Editor of the BRITISH MEDICAL JOURNAL.

Financial Secretary and Business Manager.

In view of the approaching retirement of Mr. W. E. Warne, who, having reached the age limit, will shortly leave the service of the Association, a Committee had been appointed by the Council to prepare a selected list of applicants for the post of Financial Secretary and Business Manager. Of the 280 applicants, 9 were selected by the Committee for personal interview; 3 of these were interviewed by the Council, and Mr. L. Ferris Scott, C.A., was appointed to the post. Mr. Ferris Scott has had wide experience of accountancy, secretarial work, and business organization. He served during the war in the Royal Navy and in the Royal Air Force, reaching the rank of Major.

Organization.

The report of the Organization Committee, submitted by Dr. Garstang in the absence of Mr. Russell Coombe, contained a large number of recommendations (printed in full in the Annual Report of Council, SUPPLEMENT, April 30th, 1921) whose object is to increase the efficiency of the constitution and machinery of the Association in accordance with the necessities of the present time and the probable needs of the future. In order to deal with this matter the Organization Committee, with the approval of the Council, appointed, in the first place, a special Scrutiny Subcommittee with Sir Jenner Verrall as Chairman. To that Subcommittee was referred also the question of the Association taking powers to become in part a federation of medical bodies, upon which a report appeared in the SUPPLEMENT of March 5th, 1921. The draft report on the constitution and machinery of the Association was considered by the Council paragraph by paragraph. This business occupied a large part of the first day of the Council's meeting.

Finance.

The financial statement for the year 1920 was received and approved, and ordered to be presented to the Annual Representative Meeting (see SUPPLEMENT of April 30th). The Council resolved to recommend to the Representative Body that By-law 11 be so amended that the annual subscription for members of the Oversea Branches, and also for members residing outside the United Kingdom but outside the area of any Branch, be one guinea and a half. It was further resolved that the capitation grant to be returned to all Branches be a sum not exceeding 6s. per annum, and that in the case of the Oversea Branches the maximum grant be given.

The Association as Adjudicating Body.

The Chairman of the Central Ethical Committee, in presenting his report, informed the Council that at the hearing of a case between two medical practitioners concerning the sale of a panel practice, the judge of a county court had suggested that the matter might, with advantage to the parties concerned, be referred for adjudication to the British Medical Association. The disputing parties had agreed to act upon this suggestion, and the Chairman was able to report that the Central Ethical Committee had recently adjudicated in the case.

Threatened Dismissal of Married Medical Women by Glasgow Corporation.

A report was made by the Scottish Committee that four married medical women employed by the Glasgow Corporation would be dismissed if a motion to dismiss all married women whose husbands are working were carried. Representations on the matter had also been made by the Medical Women's Federation. The Council decided to protest against interference with the private affairs of medical practitioners and against any dismissal on grounds not connected with professional capacity or willingness to do the work for which they were appointed. The Council felt that a precedent of this nature, if established, would be very undesirable and might be far-reaching.

Annual Report of Council.

The decisions and recommendations of the Council upon the many matters brought forward by the Chairmen of the Medico-Political, Public Health, Hospitals, and other Committees will be found in full in the Annual Report of Council printed in the SUPPLEMENT of April 30th.

CURRENT NOTES.

Mileage Returns, 1921.

In a circular letter dated May 3rd the Ministry of Health requests Insurance Committees to forward for 1921 a mileage return similar to that furnished in 1920—that is, a statement showing the number of insured persons on each doctor's list resident in the area where the mileage scheme applies, at a distance of more than two miles from the doctor's residence, and showing separately the number of persons resident between two and three miles, three and four miles, etc., from the doctor's residence. The Ministry explains that this request should not entail each practitioner having to supply a fresh list, as it assumes Insurance Committee clerks have kept their copies of the 1920 returns up to date by recording the additions to and removals from the list of each doctor concerned.

Hints for Insurance Practitioners.

In sending out revised copies of the local *Formulary* to practitioners on the Herts Panel, Dr. Sidney Clarke and Dr. J. J. Smith, the Honorary Secretaries of the Herts Panel Committee, have taken the opportunity to circulate in leaflet form a series of useful hints for those engaged in insurance practice. These timely exhortations and reminders are grouped under such headings as Prescribing, Medical Certificates, Complaints, Temporary Residents, Emergency Treatment. Thus, in writing prescriptions, the insurance practitioner is urged to give full and definite details of name, address, amount, etc.; to sign "per pro" when treating a patient for another doctor; to combine economy with efficiency in prescribing, and to remember that the Panel Committee has to examine the prescriptions to prevent any abuse of the Drug Fund. Again, in writing certificates he is reminded to amend the expression "today examined" if the patient has not been seen that day,

and to see chronic patients at least once a month. As will be gathered from the following examples, the style of the circular is terse and very much to the point:

"Forms of Application for Medical Cards.—(Form Med. 50 from Post Office). A batch kept by a practitioner saves many lengthy explanations."

"Record Envelopes.—Suggestions for improvements are requested."

"Assistants.—Principals must notify Insurance Committee."

"Meetings.—Do try and attend, especially the annual meeting. It helps to formulate future policy."

The example of Hertfordshire may be commended to the notice of other Panel Committees.

Fees to Scottish Practitioners called in by Midwives.

A reply to the Scottish Committee's proposal¹ has now been received from the Scottish Board of Health. The Board intimate that they are precluded under the Midwives (Scotland) Act from paying an inclusive fee to cover more than one subsequent visit, and they propose the following scale:

	£	s.	d.
(1) Fee for all attendances of a doctor at parturition (that is, from the commencement of labour until the child is born), whether operative assistance or not is involved, including one subsequent visit	1	17	6
(2) Fee for attendance of a second doctor to give an anaesthetic, whether on account of abortion or miscarriage, at parturition or subsequently	1	0	0
(3) Fee for suturing the perineum, for the removal of adherent or retained placenta, for exploration of the uterus, for the treatment of post-partum haemorrhage or for any operative emergency arising directly from parturition, including one subsequent visit	1	1	0
This fee not to be payable when the fee under 1) is payable.			
(4) Fee for attendance at, or in connexion with, an abortion or miscarriage, including one subsequent visit	1	1	0
(5) Fee for visits to mother or child not included under (1) to (4):			
Day (9 a.m. to 8 p.m.)	0	5	0
Night (8 p.m. to 9 a.m.)	0	10	0
(6) The usual mileage fee of the district to be paid for all attendances under (1) to (5) of this scale.			
(7) No fee shall be payable by the local supervising authority:			

(1) Where the doctor has agreed to attend the patient under arrangement made by or on behalf of the patient or by any club, medical institute or other association of which the patient or her husband is a member.

(2) Where the doctor receives or agrees to receive a fee from the patient or her representative.

(3) In respect of any service performed by the doctor after the expiry of four weeks from the day of birth.

The Committee has decided to take no objection to the proposed scale, provided it is clear that subsequent necessary visits will be paid for, either under the Midwives Act or through maternity and child welfare schemes, and the Board have been asked to make the position quite clear.

Association Notices.

REPRESENTATIVE MEETING.

DATE.

THE Annual Representative Meeting at Newcastle will begin on Friday, July 15th, 1921, at 10.0 a.m.

NOTICES OF MOTION AND AMENDMENT BY DIVISIONS AND BRANCHES.

The Supplementary Report of Council to the Representative Meeting will appear in the SUPPLEMENT of July 2nd, 1921.

Notices of Motion and Amendment by Divisions and Branches for consideration by the Annual Representative Meeting will be published in the SUPPLEMENT as they are received, but none can be published later than July 2nd, for which purpose they must be received by the Medical Secretary not later than the first post on Monday, June 27th.

It will be possible, however, to include in the Agenda for the Annual Representative Meeting all Notices of Motion and Amendment which are received by the Medical Secretary not later than the first post on Monday, July 4th, 1921.

¹See Annual Report of Council, paragraph 268, SUPPLEMENT, April 30th, 1921, p. 135.

ELECTION OF COUNCIL OF ASSOCIATION, 1921-22.

A LIST of the Groups of Branches in the United Kingdom for election of twenty-four Members of the Council, 1921-22, and **Nomination Form**, were published in the SUPPLEMENT of March 12th (p. 73). The **Nominations** must be in the hands of the Medical Secretary **by May 16th**.

The result of the election for Members of Council by the Groups of the Oversea Branches was published in the SUPPLEMENT of February 19th, 1921.

BRANCH AND DIVISION MEETINGS TO BE HELD.

DORSET AND WEST HANTS BRANCH.—The annual meeting of the Dorset and West Hants Branch will be held at Yeovil on Wednesday, May 18th, at 3 o'clock, when the Presidential address, on "Experience of two recent methods of treatment," will be delivered by Dr. P. C. Bottonley, O.B.E. Luncheon will be served at 1.30 p.m. at the Three Choughs Hotel, the retiring President, Dr. Wetherall, in the chair. Dr. Norman Flower kindly invites members to tea after the meeting. A motor coach has been arranged to take members from the Bournemouth district, leaving The Square at 10.30 a.m. prompt. Applications for seats should be made early to Dr. Asten, Talbot Hill, Bournemouth.

MALAYA BRANCH.—Meetings of the Malaya Branch are held in Singapore on the third Thursday of each month. Members desiring to contribute papers are requested to communicate with the honorary secretary, Dr. J. W. Scharff, care of Port Health Office, Singapore. Arrangements can be made for the exhibition of specimens or cases of interest brought to the meetings.

METROPOLITAN COUNTIES BRANCH: CITY DIVISION.—There will be a clinical meeting of the City Division on Wednesday, May 18th, at 4 p.m. at the London County Council V.D. Centre, 18, Thavies Inn, Holborn Circus, E.C., when Mr. John Adams, F.R.C.S., will show patients and give a demonstration of cases and methods. Professor Fraser (St. Bartholomew's Hospital) will give a short demonstration on two cases of unusual interest. Tea will be provided.

METROPOLITAN COUNTIES BRANCH: SOUTH-WEST ESSEX DIVISION.—The annual meeting and dinner of the Division will be held on Thursday, May 19th.

METROPOLITAN COUNTIES BRANCH: WILLESDEN DIVISION.—A meeting of members and non-members will be held on Tuesday, May 17th, at 8.30 p.m., at St. Andrew's Parish Hall (institute behind church), High Road, Willesden Green, N.W. Agenda: Minutes, correspondence, etc.; Annual Report of Executive Committee; Elect officers; Consider Annual Report of Council (SUPPLEMENT, April 30th); Any other business.

MIDLAND BRANCH: KESTEVEN DIVISION.—The annual meeting of the Division will be held at Dr. T. P. Greenwood's residence, 36, St. Mary's Street, Stamford, on Tuesday, May 31st, at 3.30 p.m. Business: (1) To elect the Chairman and Committee for the ensuing year. (2) To elect a Representative in Representative Body. For the purpose of this election, this meeting is a joint meeting of the Kesteven and Holland Divisions. (3) To discuss the agenda for the Annual Representative Meeting, and to instruct the Representative thereon. The honorary secretary, Dr. C. H. D. Robbs, informs members that he has obtained authority from the bodies concerned, throughout the Division, for the fees paid to medical practitioners called in by the police to be: day call, 7s. 6d.; night call, 10s. 6d. Tea will be provided at the conclusion of the meeting, and it is hoped that objects of interest in Stamford may be viewed.

SOUTH-WESTERN BRANCH: EXETER DIVISION.—The annual meeting of the Division will be held in the library of the Royal Devon and Exeter Hospital, on Thursday, May 26th, at 3 p.m. Tea will be provided. Agenda: Report of Executive Committee; Election of officers and representatives; Consider Annual Report of Council.

Meetings of Branches and Divisions.

CAMBRIDGE AND HUNTINGDON BRANCH: ISLE OF ELY DIVISION.

MEETINGS of the Division were held on February 22nd and April 26th. Drs. G. H. Lucas (Wisbech) and A. C. S. Waters (March) were nominated to serve on the Branch Council, and Dr. Fordyce (Cambridge) to act as representative of the Division in the Representative Body.

It was resolved to leave the question of medical representation in Parliament to individual members to support the schemes or not as they felt inclined.

The following scales of fees for police calls were directed to be submitted to the Chief Constable, with a view to their adoption:

By day (8 a.m. to 8 p.m.), 10s. 6d., with mileage at the rate of 1s. per mile extra.

By night (8 p.m. to 8 a.m.), £1 1s., with mileage as above.

The following motion for the Representative Meeting was adopted:

That the co-opted and *ex officio* members of the Insurance Acts Committee of the Association should not exceed one-fifth of the total number of the Committee.

It was decided to invite Dr. Cox to visit the Division on June 7th.

The Division approved the suggestion of the British Medical Association becoming in part a federation of medical and allied bodies.

The result of the postal vote taken of all panel practitioners in the Isle of Ely as to whether in their opinion the Insurance Acts Committee or some other body, such as the Association of Panel Committees, should represent the Panel Committees in their negotiations with the Government, showed eleven votes in favour of the Insurance Acts Committee against seven for the Association of Panel Committees.

METROPOLITAN COUNTIES BRANCH: CITY DIVISION.

A GENERAL meeting of the City Division was held on April 22nd at the Metropolitan Hospital, with Dr. CUTHBERT DIXON in the chair.

The Secretary was instructed to write to all medical officers of health in the City Division to ask them to become members or associate members of the Division. The proposed National Provident Scheme for Hospital and Additional Medical Services was read and discussed. It was resolved to express sympathy with the motive of the scheme for benefiting the hospitals in the present emergency, but to criticize the scheme even from that standpoint, believing it would not achieve its object. In the opinion of the Division the financial estimate is unduly optimistic; the additional benefits to those members of the community entitled thereto by its provisions appear to be negligible, and the benefits to the medical practitioner nebulous.

SUFFOLK BRANCH: SOUTH SUFFOLK DIVISION.

The annual general meeting of the South Suffolk Division was held on April 22nd, when the following officers were elected for the ensuing year:

Chairman: Dr. W. F. Fryer. Vice-Chairman: Dr. H. G. Biddle. Honorary Secretary and Treasurer: Dr. G. I. T. Stewart, County Hall, Ipswich.

At the instance of Dr. STEWART, Dr. W. F. Addey (Ipswich) was requested to act as Joint Secretary, so that the practising medical profession should be represented in the transactions.

NATIONAL HEALTH AND THE PRACTITIONER.

MEETING OF THE WESTMINSTER AND HOLBORN DIVISIONS.

A MEETING of the Westminster and Holborn Divisions of the British Medical Association was held in the St. James's Vestry Hall, Piccadilly, on May 6th, under the chairmanship of Dr. G. E. HASLIP, when a discussion was opened by Dr. G. F. BUCHAN, Medical Officer of Health for Willesden, on "National health and the practitioner."

Dr. BUCHAN began with a historical review of the functions of local and central health authorities, from the passing of the Public Health Act of 1875, which dealt solely with environmental conditions, down to the individualized services inaugurated of recent years. He claimed gratifying success for many of these operations. If isolation hospitals had not stamped out infectious diseases, which was their original intention, they had definitely reduced the mortality rate from such diseases. The provision of a tuberculosis service had brought about a decrease in the tuberculosis mortality. It was too early to estimate positively the influence of clinics on infant mortality, but, to take the figures for Willesden, the mortality among babies attending the clinics in 1918, 1919, and 1920 was 46, 38, and 44 per 1,000 respectively, while the general infant mortality in the same three years was 161, 110, and 76. He was not claiming that the clinic doctors were any better than the doctors in private practice, but simply that the continuous medical supervision of the child was of enormous value. Then, again, the expectation of life at birth had increased by ten years during the last forty years, and there had been an enormous reduction in the death rate, which in Willesden, in 1875, was 21.4, and last year was 9.8. The time had now arrived when the piecemeal method of attack upon single diseases or of care for the health of particular groups of the population must give place to a more comprehensive system. In Lord Dawson's Report it was accepted that the preventive and curative sides of medicine could not be separated on any sound principle. The careful practitioner would have not only to investigate the cause of disease in a particular case but to estimate its relation to the history and future of the individual. In the case of diphtheria he would not be content with sending a patient to the hospital, but he would examine the contacts, swab their throats, see that none of them were suffering from or carrying the disease, and give the whole family a clean bill of health. This involved a more complete organization of the medical profession in the conquest of disease, and the provision of better facilities. Dr.

Buchan then described how this problem had been tackled in Willesden, where the municipal hospital and clinics were provided and staffed by the local authority, and the clinic medical officers, of whom there were four, were whole-time officers, each of whom had assigned to him definite areas and sections of the population. The two clinics in Willesden had attached to them surgeons, dermatologists, oculists, gynaecologists, and ear, nose and throat specialists, and 49 beds were reserved in the hospital for cases under the observation of these specialists. He had no objection to the part-time principle, but if part-time officers took the place of the present whole-time officers their part time must be a fair and definite proportion of their time, they must fit into the general organization and discipline of the clinics, and must understand that they were the pivots of the system. He did not think that private practitioners should be allowed to go into hospital to treat their patients. The proper work of private general practitioners was out-patient and domiciliary work, and they ought to be aware when the limits of their capacity were reached. The doctor of the future would need to have higher qualifications, and longer training and a wider knowledge. The speaker believed that the ideal service which was sought could be obtained with no real loss to the individualism of which they were proud in medicine, but there must also be organization—that was to say, team work, each member of the team contributing to the common end.

Dr. CHARLES BUTTAR believed that voluntary effort could supply the increased health facilities which were necessary, but the difficulty was in its organization. The question before them was whether they were going to support the voluntary principle or accept the socialistic or State principle. On the top of the demand for State assistance in health matters were two other demands: the first, that health facilities should be a matter of right and not of charity; the second, that the stigma of the Poor Law should be removed. But the stigma of pauperism really arose from any restriction of State service to a particular class. If facilities were provided out of the pockets of the ratepayers, could the use of those facilities be denied to the people who paid for them? He believed that if the voluntary system proved impossible, and State support and control were necessary, there would be no more trouble with the medical profession than there had been with the teaching profession when education was provided by the State. But the profession ought to have a clear opinion as to whether the contemplated service should be limited or should be thrown open to the widest extent.

Dr. C. M. WILSON said that it was not at all easy to solve the question as between the voluntary and the State system. The issue was forced to the front by the financial predicament of many voluntary institutions and by the conversion of Poor Law infirmaries into municipal hospitals. He doubted whether the voluntary hospital could exist side by side with the municipal. But he did not think that the voluntary system had been used to the full extent of its resources. Its greatest failure had been the inability to make use of the general practitioner. The general practitioner would have to be brought into the hospital scheme of the future. To the apostles of State medicine he would point out that the younger generation of medical men had been through the army, where they had experienced State service and were profoundly dissatisfied with it. He believed that there must be half-time officers and that the competitive stimulus must be preserved. But no fetish should be made of either system, and the protagonists on either side might learn much from the other.

Dr. CHRISTINE MURRELL said that possibly the clinic system might continue by the half-way method of subsidized voluntary effort, and this might prove to be the permanent solution, though she was inclined to think it would be only a temporary one. If the work was done by the municipality, she thought that the clinic medical officer should be under a clinician; they were asking too much of the medical officer of health, and she objected to so much devolution of his powers, for this tended to bureaucracy. If there must be a compromise between purely voluntary effort and State effort, perhaps the relationship of the medical committee and the lay committee of a hospital might suggest a method. The medical practitioners of the district might elect a medical advisory committee out of their own number, with the medical officer of health as a member *ex officio*, perhaps its chairman, and this committee would have to do with matters relating to the medical staff, while the Public Health Committee of the municipality would form the nucleus of the lay body. She protested against one implication in Dr. Buchan's remarks: if practitioners were not fitted to follow their patients into hospital, it

meant that they ought not to treat their patients at all in illnesses serious enough to keep them in bed.

Dr. G. C. ANDERSON (Deputy Medical Secretary), speaking by invitation, said that the Association had as yet no defined policy on several of the points under discussion. But it must be remembered that there was already what amounted to a State service, comprising maternity and child welfare services, tuberculosis and venereal diseases services, national health insurance services, and others. Medical men throughout the country had only their previous apathy to blame if they were not at the present time participating in the various clinics as they might be doing. They largely neglected the invitation to discuss the matter which was offered to them when the maternity and child-welfare clinics were first mooted. On the question of whole-time *versus* part-time officers he did not see why the ordinary general practitioner was not as competent to learn the duties appertaining to the clinic organization as the whole-time officers already employed by the local authority. It was essential that the profession should soon formulate its policy. Possibly before very long the Labour party would be in power, and the Labour party appeared to be the only political party to have a declared health policy. It was time that the medical profession took the lead, and he hoped that the discussion at the forthcoming Representative Meeting on the report of the Medical Consultative Council would assist in that direction.

Dr. A. C. FARQUHARSON, M.P., said that he had not realized until that afternoon that there was so definite a cleavage as to the lines of future effort and progress. Dr. Buchan had fortified his advocacy of team work by a reference to the want of equipment of the general practitioner, and had implied that the general practitioner was unadaptable, lacking in knowledge, and unaccustomed to discipline. As for this last quality, he would remind Dr. Buchan that a man who had had to school himself to answer the night-bell was not exactly unused to discipline. The discussion came down to the old question of State as against private enterprise, for Dr. Buchan's idea of team work was of a work linked up and controlled by the State. Instructive parallels might be drawn from other fields. Whenever the State had undertaken functions which distinctively belonged to private enterprise, the State had made a signal failure. He served for fourteen months on a departmental committee to inquire into the expediency of transferring a certain service from private to State enterprise, and at the end he was absolutely convinced that the State should have nothing to do with it, and that was the tenor of the report eventually issued. A system of State enterprise controlling the health of the people would be futile. He believed the medical equipment, discipline, and ability of the general practitioner to be absolutely sufficient for the needs of national health. The general tendency of all these schemes was to encourage passivity on the part of the people who received attention. He made an exception in the case of children—and he was glad to see that the health estimates had gone up by £400,000 in regard to maternity and child welfare for 1922—but beyond this, in tuberculosis and other matters affecting the adult, the tendency of State aid was to encourage personal irresponsibility and sap the fibre of the nation. He declared himself an absolute opponent of Lord Dawson's scheme. The primary health centre of this country was the home.

Dr. HASLIP said that the words which Dr. Farquharson had addressed to them were well enough for the political platform but not quite so effective in medical hearing. They knew very well that the nation demanded an "A 1" population. Medical men had been in the homes of the poorer classes and knew of the ignorance which existed. That was why voluntary help was originally started, and as the need enlarged and the voluntary support was found to be insufficient the State had to step in. He believed that whatever medical service was given to the nation should be absolutely free and open to all. A restriction to income limits would make the stigma reappear. Yet all the schemes produced by the medical profession were based on some such restriction. Those who fought the battle of the Insurance Act knew that to fight any other question on the income limit in the future would be futile. There should only be two categories in the classification of patients—namely, those who availed themselves of the systematized general medical service, which was free and open to all and for which no direct charge was made; and those who did not avail themselves of that service, but preferred to go to their private doctors. The failure of the Insurance Act had come about because it was neither one thing nor the other. It was not private practice, for there was State intervention by means of inspectors and so forth. The

Insurance Act would have to be scrapped. If the State medical service were carried out by part-time medical officers there would be no need whatever for inspectors because of the free criticism which would exist among the practitioners themselves. Remuneration was, of course, a big question. Medical men were ready to give their services gratuitously to the poorer classes of the community. If the State considered that those services should be paid for, then the medical profession should recognize that the rate of remuneration must not be the same as that which was charged in the case of their private patients. It was only by such moderation that they were going to prevent the future introduction of a whole-time medical service, which he hoped would not materialize. He knew that his views in some respects were not those of the majority of the profession, but he believed they were the views which would obtain in the future, and that future was nearer at hand than they thought.

Dr. BUCHAN confined his reply to answering a remark by Dr. Murrell. She had objected to the clinic medical officer being under the medical officer of health. As a matter of fact, it was not the medical officer of health who advised the clinic medical officer; on the contrary, the clinic medical officer advised the medical officer of health.

Correspondence.

Anaesthetists' Fees in Insurance Practice.

SIR,—Dr. Gordon Ward's letter in the SUPPLEMENT of May 7th (p. 171) deserves careful consideration by every panel practitioner.

The only safe policy for Panel Committees to adopt is one which draws a hard and fast line between "domiciliary" and "institutional" treatment. If the profession once allows remuneration to be granted from the local medical pool even for one "regulation" service rendered to an insured person during his stay in an institution, it must logically concede that all other "regulation" services during such stay may be remunerated from the same source—that is, (a) payment for temporary residents; (b) payment for emergency treatment, payment to deputies; (c) the supply of anaesthetics, drugs, dressing and certain appliances either by (i) the practitioner for his dispensing patients or (ii) by the State for those patients who obtain their drugs from the chemists.

Let us, as members of the staff, continue our voluntary attendance to insured patients in our institutions until such time as the injustice of the present system is recognized and adequate payment is provided for such services; then we shall be free to demand our fair share of such extra remuneration. The argument used that the practitioner should not be done out of his guinea, just because the patient has moved from one house to another, is a picture of the patient beast putting his head through the collar to nibble a carrot; he munches his carrot, but finds there is a cart behind the collar, and he will have to draw that cart as long as the driver cracks his whip, no matter how the load strengthens as the journey lengthens.—I am, etc.,

Bratton, Wilts, May 7th.

T. WOOD LOCKET.

Naval and Military Appointments.

ROYAL NAVAL MEDICAL SERVICE.

The following notifications are announced by the Admiralty: Surgeon Lieutenant Commander H. B. Porter, D.S.C., to the *Pembroke*, additional.

Surgeon Lieutenant Commander B. E. P. Sayers has withdrawn with a gratuity, April 22nd. (In substitution of previous notification.)

Surgeon Lieutenant A. McCallum has been transferred to the Royal Canadian Navy.

ARMY MEDICAL SERVICE.

ROYAL ARMY MEDICAL CORPS.

Captain E. Catford relinquishes the acting rank of Major. The following officers relinquish their commissions: Temporary Captain (acting Major) A. G. Macdonald, O.B.E., and is granted the rank of Major; temporary Captain F. L. Dickson; temporary Captains and retain the rank of Captain: J. Crean, E. S. Joske, T. H. Jackson, W. B. Gourlay, M.C., R. W. Collum; temporary honorary Captain B. D. Booker and retains the honorary rank of Captain.

ROYAL AIR FORCE.

MEDICAL BRANCH.

The following are granted temporary commissions as Flight Lieutenants with effect from and with seniority of the dates indicated: C. P. Barber (May 2nd), J. F. P. Gallagher (April 18th), H. C. E. Quinn (April 8th), C. A. E. I. Brownlee (May 9th).

Captains transferred to the unemployed list: G. M. Mellor, C. E. Lowe.

INDIAN MEDICAL SERVICE.

Major (Brevet Lieut.-Colonel) F. A. F. Barnardo, C.B.E., C.I.E., appointed to officiate as Principal and Professor of Medicine, Medical College, Calcutta, and First Physician to the College Hospitals.

Lieut.-Colonel F. W. Sumner appointed to officiate as Civil Surgeon, Simla East.

Dr. Gangadhar Ramchandra Tambur appointed to officiate as Professor of Ophthalmology at King George's Medical College, Lucknow.

Major A. S. Leslie appointed as Superintendent of the Callular and Female Goals, Port Blair.

Lieut.-Colonel E. D. W. Greig, C.I.E., D.S.C., Officiating Director Pasteur Institute, Kasauli, appointed substantively *pro tempore* to be Director of Medical Research.

The undermentioned officers have been permitted to retire from the service, with effect from the dates specified: Colonel G. J. H. Bell, C.I.E. (August 20th, 1920); Lieut.-Colonel C. C. S. Barry, C.I.E. (February 9th, 1920); Lieut.-Colonel H. B. Melville (January 22nd, 1921); Major V. B. Nesfield (March 9th, 1921).

Major T. C. Boyd has been appointed as a probationer in the Chemical Examiner's Department, and has been attached to the Chemical Examiner's Laboratory, Lahore.

Major J. J. Robb promoted to the rank of Lieutenant-Colonel (July 29th, 1920).

TERRITORIAL FORCE.

ROYAL ARMY MEDICAL CORPS.

Major G. B. Robinson to be D.A.D.M.S., 44th (Home Counties) Division.

Captain E. A. Houchin resigns his commission and is granted the rank of Lieutenant-Colonel.

Captains to be Majors: T. A. Hindmarsh, G. E. J. A. Robinson, F. R. M. Higgs, E. L. D. Dewdney.

TERRITORIAL FORCE RESERVE.

ROYAL ARMY MEDICAL CORPS.

The announcements regarding Captain D. L. Wall, M.C., and Captain A. R. Moodie, which appeared in the *London Gazette* of June 7th, 1918, and October 11th, 1918, respectively, are cancelled.

Captain A. Coleridge to be Major.

DEFENCE FORCE.

ARMY MEDICAL SERVICE.

R.A.M.C.—To be temporary Majors: C. Walker, F. Ward, J. E. Bates, P. McK. Terry, T. D., A. G. Reid, A. Robertson, O. B. E. To be temporary Captains: J. Morham, W. George, M. C., A. C. H. McCullagh, D. S. O., S. J. Clegg, O. B. E., W. A. Jackman, H. Mather, J. A. Mathers, G. M. Campbell, M. C., W. R. Watt, E. E. Elliott, C. H. Vernon, K. Pretty, H. G. Greaves. To be temporary Lieutenant: G. J. Scale.

2nd (East Anglian) Field Ambulance (D.F.).—To be temporary Major: S. J. Fielding.

1st (Highland) Field Ambulance (D.F.).—To be temporary Captain: F. M. Rorie.

3rd (Northumberland) Field Ambulance (D.F.).—To be temporary Lieutenant-Colonel: W. A. Thompson.

1st (West Lancashire) Field Ambulance (D.F.).—To be temporary Major: F. W. B. Young.

2nd (West Lancashire) Field Ambulance (D.F.).—To be temporary Lieutenant-Colonel: G. C. E. Simpson.

1st (West Riding) Field Ambulance (D.F.).—To be temporary Major: L. A. Mackenzie, M. C. To be temporary Captains: J. H. Blackburn, M. C., A. Ellison, W. S. Sykes, A. A. Roberts.

DIARY OF SOCIETIES AND LECTURES.

ROYAL SOCIETY OF MEDICINE.—*Section of History of Medicine*: Wed., 5 p.m., Annual General Meeting; Dr. Charles G. Cumston (Geneva): Historical Summary of the Treatment of Trachoma, with special reference to the Arabians School and the Writings of Ali-ibn-el-Aissa. *Section of Surgery*: Wed., 5.30 p.m., Annual General Meeting; Exhibition of Specimens of Diseases and Tumours of Bone. *Section of Dermatology*: Thurs., 4.30 p.m., Cases; 5 p.m., Annual General Meeting. *Section of Otolaryngology*: Fri., 5 p.m., Annual General Meeting; Mr. J. S. Fraser: Demonstration on the Pathology of Deaf-Mutism; Mr. F. J. Cleminson: Sinusitis in Children; Mr. Harry Brook: Exhibition of Casts of Congenital Malformations of the Ear and Artificial Ears. *Section of Electro-Therapeutics*: Fri., 8.30 p.m., Annual General Meeting. Informal Clinical Evening: Discussion on The Stomach, to be opened by the President and Dr. Knox. Demonstration of the Potter-Bucky Diaphragm.

ROYAL SOCIETY OF TROPICAL MEDICINE AND HYGIENE, 11, Chandos Street, W.—Fri., 7.45 p.m., Microscopic Demonstrations: 8.15 p.m., Papers:—Lieut.-Colonel H. Kirkpatrick, I.M.S. ret.: Trachoma; Claud H. Marshall: New Method of Treatment of Human Trypanosomiasis; Carlos França: An Early Portuguese Contribution to Tropical Medicine.

POST-GRADUATE COURSES AND LECTURES.

GLASGOW POST-GRADUATE MEDICAL ASSOCIATION, Royal Samaritan Hospital for Women, Wed., 4.15 p.m., Dr. Shannon: Gynaecological Cases.

INSTITUTE OF PATHOLOGY AND RESEARCH, St. Mary's Hospital, Paddington, W.—Thurs., 4.30 p.m., Professor H. H. Dale, F.R.S.: Anaphylaxis and Immunity.

LONDON HOSPITAL MEDICAL COLLEGE.—Tues. and Fri., 5.15 p.m., Dr. M. Culpin: Psycho-neuroses.

NATIONAL HOSPITAL FOR THE PARALYSED AND EPILEPTIC, Queen Square, W.C.—Tues., Thurs., and Fri., 2 p.m.: Out-patient Clinics. Tues., 3.30 p.m., Dr. R. Russell: Demonstration of Cases. *Lectures*: 3.30 p.m., Thurs., Mr. Scott: Vertigo; Fri., Dr. G. Stewart: Spinal Curves.

QUEEN'S HOSPITAL FOR CHILDREN, Hackney Road.—Thurs., 4 p.m., Mr. B. W. Howell: Principles of Orthopaedic Surgery.

WEST LONDON POST-GRADUATE MEDICAL COLLEGE, Hammersmith, W.—Daily, 10 a.m. (and Fri., 2.30 p.m.), Ward Visits; 2 p.m., In- and Out-patient Clinics and Operations. Wed., 11 a.m., Mr. MacDonald: Demonstration of Cystoscopy. Thurs., Dr. S. Pinchin: Diseases of the Heart. *Lectures*: 5 p.m., Tues., Dr. Burnford: Infective Endocarditis. Wed., Dr. Owen: Nephritis. Thurs., Sir R. Armstrong-Jones: Analysis of Mind and Value of Psycho-Therapy. Fri., Mr. MacDonald: Sexual Disabilities in the Male.

British Medical Association.

OFFICES AND LIBRARY, 429, STRAND, LONDON, W.C.2.

Reference and Lending Library.

THE READING ROOM, in which books of reference, periodicals, and standard works can be consulted, is open to members from 10 a.m. to 6.30 p.m., Saturdays 10 to 2.

LENDING LIBRARY: Members are entitled to borrow books, including current medical works; they will be forwarded, if desired, on application to the Librarian, accompanied by 1s. for each volume for postage and packing.

Departments.

SUBSCRIPTIONS AND ADVERTISEMENTS (Financial Secretary and Business Manager, Telegrams: Articulate, Westrand, London), MEDICAL SECRETARY (Telegrams: Medisecra, Westrand, London), EDITOR, *British Medical Journal* (Telegrams: Aitiology, Westrand, London).

Telephone number for all Departments: Gerrard 2630 (3 lines).

SCOTTISH MEDICAL SECRETARY: 6, Rutland Square, Edinburgh. (Telegrams: Associate, Edinburgh. Tel.: 4361 Central.)

IRISH MEDICAL SECRETARY: 16, South Frederick Street, Dublin. (Telegrams: Bacillus, Dublin. Tel.: 4737 Dublin.)

Diary of the Association.

MAY.

- 13 Fri. London: Medico-Sociological Committee, 2.30 p.m.
Camberwell Division: Annual General Meeting, Camberwell Infirmary, 3.30 p.m.
- 17 Tues. Willesden Division, St. Andrew's Parish Hall, High Road, Willesden Green, N.W., 8.30 p.m.
- 18 Wed. City Division, Clinical Meeting, London County Council Venereal Disease Centre, 18, Thavies Inn, Holborn Circus, E.C., 4 p.m.
Dorset and West Hants Branch, Annual Meeting, Yeovil, 3 p.m.; Luncheon, 1.30 p.m.
- 19 Thurs. South-West Essex Division: Annual Meeting and Dinner.
- 26 Thurs. London: Insurance Acts Committee, 2.30 p.m.
Exeter Division, Annual Meeting, Royal Devon and Exeter Hospital, 3 p.m.
- 31 Tues., Kesteven Division Annual Meeting, 36, St. Mary's Street, Stamford, 3.30 p.m.

APPOINTMENTS.

- BERRY, W. A., M.D. (State Med.) Lond., D.P.H. Oxon., Medical Officer of Health for Bloemfontein, South Africa.
- CORBETT, Captain W. Victor, M.R.C.S., L.R.C.P., Pathologist to the London Lock Hospital, vice L. D. Shaw, M.B., Ch.B., deceased.
- FISHER, A. G. Timbrell, M.C., M.B., Ch.B., F.R.C.S. Eng., Surgeon with charge of Out-patients to the Seamen's (Dreadnought) Hospital, Greenwich.
- ROWLANDS, Robert, L.M.S.S.A. Lond., Medical Officer and Public Vaccinator to the Criccieth District of the Pwllheli Union, North Wales.
- RUSSELL, M. J., F.R.C.S.I., L.R.C.P.I., D.P.H., Executive Sanitary Officer and Medical Superintendent Officer of Health, Dublin.
- SCARLETT-SYNGE, Mrs. Ella, M.D., Resident Medical Officer to Kinderheim, "Deutsch-America," Nordholz, bei Cuxhaven.
- STIRLING, J. A., M.B., Ch.B. Edin., Assistant Medical Officer of Health to the Cumberland County Council.

BIRTHS, MARRIAGES, AND DEATHS.

The charge for inserting announcements of Births, Marriages, and Deaths is 9s., which sum should be forwarded with the notice not later than the first post on Tuesday morning, in order to ensure insertion in the current issue.

BIRTH.

NEVE.—On May 8th, at Barnhill, Bromley, Kent, the wife of Dr. Ernest F. Neve, of a daughter—stillborn.

MARRIAGES.

- MACDOWELL—BEMROSE.—At Newark, Notts, on May 5th, 1921, S. Edgar Creighton MacDowell, M.D., C.M., L.R.C.P. Lond., etc., of Liverpool, to Ada Lydia (Trout) Bemrose, of Denver House, Freston Green, Caythorpe, Grantham, Lincs.
- SUTTON—WILSON.—On Easter Monday, at Cape Town, Philip Schreiner youngest son of the Rev. J. G. Sutton, M.A., Rector, Dale College, and the late Mrs. Sutton of Kingwilliamstown, to Ada, fifth daughter of the late Thomas Wilson, J.P., ex. Longford, M.R.C.S., L.R.C.P., and Mrs. Wilson of Edgeworthstown.
- WILSON—BOYD.—On May 3rd, at Glasgow, Kenneth John Talbot, M.B., Ch.B., of Blandford, Dorsetshire, eldest son of Mr. Talbot E. B. Wilson, J.P., of Sheffield, to Agnes Mitchell, second daughter of Mr. David M. Boyd, of Giffnock, Glasgow.

SUPPLEMENT

TO THE

BRITISH MEDICAL JOURNAL.

LONDON: SATURDAY, MAY 21st, 1921.

CONTENTS.

	PAGE		PAGE
BRITISH MEDICAL ASSOCIATION.			
ANNUAL MEETING AT NEWCASTLE.		Scottish Consultative Council's Report: VIEWS OF THE	
Programme	189	ROYAL COLLEGE OF PHYSICIANS OF LONDON	193
Provisional Time Table	191	CORRESPONDENCE:	
Accommodation at Newcastle	191	A MEDICAL SERVICE SCHEME FOR SCOTLAND	195
ASSOCIATION NOTICES:		INSURANCE REMUNERATION	195
DATE OF REPRESENTATIVE MEETING	192	INSURANCE:	
ELECTION OF COUNCIL: NOMINATIONS	192	MEETING OF BUCKINGHAMSHIRE PRACTITIONERS	195
NOTICES OF MOTION FOR ANNUAL REPRESENTATIVE MEETING	192	NAVAL AND MILITARY APPOINTMENTS...	196
MEETINGS OF BRANCHES AND DIVISIONS	193	DIARY OF SOCIETIES AND LECTURES	196
MEETINGS TO BE HELD...	193	APPOINTMENTS...	196
ASSOCIATION INTELLIGENCE	196	BIRTHS, MARRIAGES, AND DEATHS	196

British Medical Association.

EIGHTY-NINTH ANNUAL MEETING, NEWCASTLE-UPON-TYNE, JULY, 1921.

Patron: HIS MAJESTY THE KING.

President: The Right Hon. Sir T. CLIFFORD ALBUTT, P.C., K.C.B., F.R.S., Regius Professor of Physic, University of Cambridge.

President-Elect: DAVID DRUMMOND, C.B.E., M.A., M.D., D.C.L., Vice-Chancellor and Professor of the Principles and Practice of Medicine, University of Durham.

Chairman of Representative Meetings: T. W. H. GARSTANG, M.A., M.R.C.S., D.P.H.

Chairman of Council: R. A. BOLAM, M.D., M.R.C.P.

Treasurer: G. E. HASLIP, M.D.

PROGRAMME.

The President, Professor DAVID DRUMMOND, will give an Address on Tuesday, July 19th, at 8 p.m.

The ANNUAL REPRESENTATIVE MEETING will begin on Friday, July 15th, at 10 a.m., and be continued on the following days.

The REPRESENTATIVES' DINNER will be held on Friday, July 15th, at 7.30 p.m.

The statutory ANNUAL GENERAL MEETING will be held on July 19th, at 2 p.m., and the Adjourned General Meeting at 8 p.m.

The Annual Dinner of the Association will take place on Thursday, July 21st, at 7.30 p.m.

Religious services will be held on Tuesday, July 19th, at 5 p.m.

The Conference of Secretaries will be held at 2 p.m. on Wednesday, July 20th, and the Secretaries' Dinner will take place in the evening at 6.30.

A Special Address on Industrial Medicine will be given by Sir Thomas Oliver, LL.D., M.D., F.R.C.P., on Wednesday, July 20th, at 8 p.m.

The Popular Lecture, on "Evolutionary Wounds," will be delivered by Professor Arthur Keith, F.R.S., on Friday, July 22nd, at 7.30 p.m.

THE SCIENTIFIC SECTIONS.

The Sections will meet from 10 a.m. to 1 p.m. Laboratory and Clinical Demonstrations will be given on Wednesday, July 20th, Thursday, July 21st, and Friday, July 22nd, between 3 p.m. and 4.50 p.m.

The following Sections meet on three days—Wednesday, Thursday, and Friday, July 20, 21, and 22.

MEDICINE.

President: Professor THOMAS BEATTIE, M.D., F.R.C.P.

Vice-Presidents: The Right Hon. LORD DAWSON OF PENN, G.C.V.O., M.D., F.R.C.P.; Professor A. J. HALL, M.D., F.R.C.P.; G. S. HAYNES, M.D., M.R.C.P.; J. WILKIE SMITH, M.D.

Honorary Secretaries: C. E. LAKIN, M.D., F.R.C.P., (405, Harley Street, London, W.1); W. T. RITCHIE, O.B.E., M.D., F.R.C.P.Ed. (14, Rothesay Place, Edinburgh); Professor W. E. HUME, C.M.G., M.D., F.R.C.P. (3, Ellison Place, Newcastle-on-Tyne).

The following provisional programme has been arranged:—
July 20th (10 a.m.).—Discussion: Visceral Syphilis, especially of the Central Nervous System and Cardio-Vascular System. To be introduced by the Right Hon. Sir CLIFFORD ALBUTT, K.C.B., F.R.S., followed by Dr. Gordon Holmes, Professor Reynolds, Dr. John Cowan, Dr. A. G. Gibson, Dr. John Eason and Dr. Ivy McKeuzie.

July 21st (10 a.m.).—Discussion: Asthma and Allied Disorders. To be opened by Sir HUMPHRY ROLLESTON, K.C.B., followed by Dr. John Freeman, Dr. A. F. Hurst, Mr. Frank Coke, Dr. Mackenzie Wallis and Dr. Charles McNeil.

July 22nd (10-11.30 a.m.).—Discussion: Encephalitis Lethargica. To be opened by Dr. EDWIN BRAMWELL, followed by Dr. Wilfred Harris, Professor A. J. Hall, Dr. C. H. Melland. (11.30 a.m.-1 p.m.).—Discussion: Renal Efficiency Tests. To be opened by Professor H. McLEAN, followed by Professor Boyd.

In the afternoons of Wednesday, Thursday and Friday, from 3 to 4.30, cases will be demonstrated by the honorary medical staff in the medical wards of the Royal Victoria Infirmary. Short papers and demonstrations will be arranged during the same hours.

Anyone wishing to take part in the above discussions, or give demonstrations, is asked to communicate with Dr. W. E. Hume, Honorary Secretary, Section of Medicine, 4, Ellison Place, Newcastle-on-Tyne, in order that he may forward a copy of the organizer's remarks when available.

SURGERY.

President: Professor J. RUTHERFORD MORISON, D.C.L., LL.D., F.R.C.S.

Vice-Presidents: Professor H. BRUNTON ANGUS, F.R.C.S.; ARTHUR COOKE, F.R.C.S.; W. J. GREER, F.R.C.S.I.; A. M. MARTIN, M.B.

Honorary Secretaries: W. GIRLING BALL, F.R.C.S. (77, Wimpole Street, London, W.1); J. M. RENTON, F.R.C.S. (16, Sandford Place, Glasgow, W.); G. GREY TURNER, M.S., F.R.C.S., F.A.C.S. (The Hawthorns, Osborne Road, Newcastle-on-Tyne).

The following provisional programme has been arranged:

July 20th (Morning Session).—Discussion: Acute Pleural Empyema. To be opened by Mr. HENRY WADE, C.M.G., D.S.O., M.D., F.R.C.S. (Edinburgh).

In the afternoon, at 3 o'clock, demonstrations will be given by Professor RUTHERFORD MORISON at the War Pensions Hospital of cases and specimens illustrating (1) Bipp, (2) Bone Cavities, (3) Bone Grafts. Cases will also be shown by other members of the staff.

July 21st (Morning Session).—Discussion: Compound Fracture of the Thigh and Leg.

In the afternoon, at 3 o'clock, demonstrations will be given at the Royal Victoria Infirmary of cases and specimens illustrating Compound Fracture of the Thigh and Leg.

July 22nd (Morning Session).—Discussion: The Diagnosis and Treatment of Injuries of the Intestines. To be opened by Mr. GORDON TAYLOR, O.B.E., M.S. (London).

In the afternoon, at 3 o'clock, demonstrations will be given by Mr. G. GREY TURNER at the Royal Victoria Infirmary of six cases of implantation of the ureter into the bowel.

Operations will be arranged by the staff of the Royal Victoria Infirmary for each afternoon at 2 o'clock.

One or two short papers will also be read on each day after the discussion.

Anyone wishing to take part in the discussions or demonstrations is invited to communicate with the Secretaries, and those wishing to read short papers are asked to send a summary, to be brought before the officers of the Section. There will also be an exhibition of specimens illustrating the subjects for discussion, and members are asked to advise the Secretaries of any specimens they propose to exhibit.

PATHOLOGY AND BACTERIOLOGY.

President: Professor STUART McDONALD, M.D., F.R.C.P. (Ed.).
Vice-Presidents: J. F. GASKELL, M.D., F.R.C.P.; JAMES A. MURRAY, M.D.; Professor MATTHEW J. STEWART, M.B., M.R.C.P.

Honorary Secretaries: R. R. ELWORTHY, O.B.E., M.D., M.R.C.P. (West London Hospital, Hammersmith, London, W.6); A. F. BERNARD SHAW, M.D., M.R.C.P.I. (Pathological Department, College of Medicine, Newcastle-on-Tyne).

Pathological Museum.

The Pathological Museum Committee proposes to arrange the material under the following heads: (1) Exhibits bearing on discussions and papers to the various Sections; (2) specimens and illustrations relating to any recent research work; (3) instruments relating to clinical diagnosis and pathological investigation; (4) individual specimens of special interest or a series illustrating some special subject. It is proposed to gather together a series of exhibits illustrating the pathology of individual cases. Such exhibits will include a brief clinical history of the case and mounted specimens of the different organs and tissues illustrating the pathological changes and the correlation of the lesions. Other interesting specimens will be welcomed. The Honorary Secretary of the Pathological Museum Committee is Dr. A. F. Bernard Shaw, Pathological Department, College of Medicine, Newcastle-upon-Tyne. The museum will occupy a central position in the same building as that in which the sectional work is carried on. Every care will be taken of specimens, and the contents of the museum will be insured. It is hoped to make arrangements for exhibitors to demonstrate their specimens.

PREVENTIVE MEDICINE WITH INDUSTRIAL DISEASES.

President: Sir THOMAS OLIVER, LL.D., M.D., F.R.C.P.
Vice-Presidents: Sir JOSIAH COURT, M.R.C.S.; T. EUSTACE HILL, O.B.E., M.B.; I. G. MODLIN, O.B.E., M.D.
Honorary Secretaries: C. M. WILSON, M.C., M.D. (64, South Audley Street, Grosvenor Square, W.1); W. H. DICKINSON, O.B.E., M.B., D.F.H. (1, Ridley Villas, Newcastle-on-Tyne).

ORTHOPAEDICS AND DISEASES IN CHILDREN.

President: A. H. TUBBY, C.B., C.M.G., M.S., F.R.C.S.

Vice-Presidents: R. C. ELSLIE, O.B.E., M.S., F.R.C.S.; H. MORLEY FLETCHER, M.D., F.R.C.P.; LACHLAN G. FRASER, M.D.; Sir HENRY M. W. GRAY, K.B.E., C.B., C.M.G., F.R.C.S.; A. E. MORISON, F.R.C.S. (Edin.) (Director of Demonstrations).

Honorary Secretaries: C. MAX PAGE, D.S.O., F.R.C.S. (134, Harley Street, London, W.1); FRANK HAWTHORN, D.S.O., M.D. (10, Ellison Place, Newcastle-on-Tyne); H. R. SOUPER, M.D. (Ministry of Pensions Hospital, Castle Leazes, Newcastle-on-Tyne).

The following preliminary programme has been arranged:

July 20th (10 a.m.).—Chairman: Mr. A. H. Tubby. Discussion: The Early Diagnosis and Treatment of Anterior Poliomyelitis.

July 21st (10 a.m.).—Chairman: Dr. H. Morley Fletcher. Discussion: Blood Diseases in Children.

July 22nd (10 a.m.).—Chairman: Sir Henry M. W. Gray. Discussion: Tuberculosis of Bone; General Principles of Treatment.

The following Sections meet on two days—Wednesday and Thursday, July 20 and 21.

NEUROLOGY AND PSYCHIATRY.

President: Professor A. W. MACKINTOSH, M.D., F.R.C.P. (Ed.).

Vice-Presidents: A. HELEN A. BOYLE, M.D.; E. FARQUHAR BUZZARD, M.D., F.R.C.P.; HARRY CAMPBELL, M.D., F.R.C.P.; HORSLEY DREUMOND, M.D.

Honorary Secretaries: ANTHONY FEILING, M.D. (41, Devonshire Street, London, W.1); GEORGE HALL, C.M.G., M.D., M.R.C.P. (1, Eslington Road, Jesmond Road, Newcastle-on-Tyne).

The following provisional programme has been arranged:

July 20th (10 a.m.).—Discussion: The Diagnosis and Treatment of Borderland Cases. To be opened by Professor G. M. ROBERTSON (Edinburgh) and Dr. JAMES COLLIER (London).

July 21st (10 a.m.).—Papers.

OPHTHALMOLOGY.

President: Professor J. D. WARDALE, M.B., B.S.

Vice-Presidents: H. P. BENNETT, M.B.; Lieut.-Colonel R. H. ELLIOT, M.D., F.R.C.S., I.M.S. (ret.); HARRY M. TRAQUAIR, M.D., F.R.C.S. (Ed.).

Honorary Secretaries: N. B. B. FLEMING, M.B., Ch.B. (9, Harley Street, London, W.1); STANLEY ROBSON, M.S., F.R.C.S. (Ed.) (Milton House, Rowlands Gill, co. Durham).

The following provisional programme has been arranged:

July 20th (10 a.m.).—Discussion: The Causes and Prevention of Blindness. To be opened by Mr. BISHOP HARMAN, F.R.C.S. (London).

July 21st (10 a.m.).—Discussion: The Treatment of Corneal Ulcers. To be opened by Mr. J. V. PATERSON, F.R.C.S. (Edin.) (Edinburgh).

OTO-RHINO-LARYNGOLOGY.

President: G. WILLIAM HILL, M.D., B.Sc.

Vice-Presidents: R. GORDON BELL, M.D., F.R.C.S. (Edin.); JAMES DON, M.D.; DAN MCKENZIE, M.D., F.R.C.S. (Edin.).

Honorary Secretaries: LIONEL COLLEDGE, M.B., F.R.C.S. (22 Queen Anne Street, London, W.1); W. FRANK WILSON, M.B., B.S. (97, Jesmond Road, Newcastle-upon-Tyne).

The following provisional programme has been arranged:

July 20th (10 a.m.).—Discussion: Problems in connexion with the Early Diagnosis and Treatment of Meningitis occurring in Antral Cases. To be opened by Sir CHARLES BALANCE, K.C.M.G., C.B.

July 21st (10 a.m.).—Discussion: The Various Problems presented by Haemorrhage occurring in connexion with Operations on the Tonsils.

PHYSIOLOGY, PHARMACOLOGY, THERAPEUTICS, AND DIETETICS.

President: H. H. DALE, C.B.E., M.D., F.R.S.

Vice-Presidents: Professor A. V. HILL, M.A., D.Sc., F.R.S.; Professor JOHN C. MEAKINS, M.D.; Professor J. A. MENZIES, M.D.; ALFRED PARKIN, M.D., M.R.C.P.

Honorary Secretaries: O. INCHLEY, M.A., M.D. (Babraham, Cambridge); Miss MILDRED ATKINSON, B.Sc. (College of Medicine, Newcastle-on-Tyne).

VENEREAL DISEASES.

President: Colonel L. W. HARRISON, D.S.O., R.A.M.C.

Vice-Presidents: JAMES CHARLES BUCKLEY, M.D.; CHARLES GIBBS, F.R.C.S.; MARY RAW, M.B.

Honorary Secretaries: KENNETH M. WALKER, O.B.E., F.R.C.S. (86, Harley Street, London, W.1); JAMES HUDSON, M.D. (42, Crossley Terrace, Newcastle-on-Tyne).

The following provisional programme has been arranged:

July 20th (10 a.m.).—Treatment of Syphilis in Men, by Dr. R. MacKenna. Syphilis in Women and Children, by Professor Walter Swayne.

July 21st (10 a.m.).—Treatment of Gonorrhoea in Men, by Dr. David Lees. The Standard of Cure in Gonorrhoea, by Dr. Towaley Clarkson.

In the afternoon of Wednesday (July 20th) a demonstration will be held of Methods of Diagnosis and Treatment in Venereal Diseases, Dark-ground Illumination Work, Models of Venereal Disease Clinics, etc.

The following Section meets on two days—Thursday and Friday, July 21 and 22.

OBSTETRICS AND GYNAECOLOGY.

President: Professor R. P. RANKEN LYLE, M.D.
Vice-Presidents: Lady BARRETT, M.D.; W. R. GROVE, M.D.; WILLIAM ROBINSON, F.R.C.S.
Honorary Secretaries: GORDON LEY, F.R.C.S. (5, Wimpole Street, London, W.1); MABEL R. CAMPBELL, M.A., M.B. (49, Wingrove Road, Newcastle-on-Tyne); E. FARQUHAR MURRAY, M.D., F.R.C.S. (52, Jesmond Road, Newcastle-on-Tyne).

The following provisional programme has been arranged:
July 21st (10 a.m.).—Discussion: The Role of Caesarean Section in Midwifery. To be opened by Dr. EARDLEY L. HOLLAND (London) and Dr. J. M. MUNRO KERR (Glasgow). Paper: The Treatment of Advanced Malignant Disease of the Cervix, by Dr. ARTHUR BURROWS (Manchester), to be followed by a discussion.
July 22nd (10 a.m.).—Discussion: The Neurasthenic Element in Midwifery and Gynaecology. To be opened by Dr. ARCHIBALD DONALD (Manchester) and Dr. FARQUHAR BUZZARD (London). Papers to be followed by discussion: (1) Curettage, (a) Diagnostic, (b) Treatment of Uterine Haemorrhage, by Dr. H. BECKWITH WHITEHOUSE (Birmingham). (2) The Position of the Medical Practitioner called in to attend a case of Procured Abortion, by Dr. JOHN CAMPBELL (Belfast).

The following Sections meet on one day as indicated.

Wednesday, July 20th.

AMBULANCE AND RED CROSS.

President: Sir JAMES CANTLIE, K.B.E., F.R.C.S.
Vice-Presidents: ROBERT ANDERSON, M.D.; Sir G. T. BRATSON, K.C.B., K.B.E., M.D.; Major-General Sir G. J. H. EVATT, K.C.B., M.D.; Rev. C. F. TOWNLEY, M.A.
Honorary Secretaries: Lieut.-Colonel R. M. VICK, O.B.E., F.R.C.S., The Warden's House, St. Bartholomew's Hospital, E.C.1; H. L. RUTHER, M.B.E., F.R.C.S. (51, West Parade, Newcastle-on-Tyne).

PROCTOLOGY.

President: J. P. LOCKHART-MUNNERY, F.R.C.S.
Vice-Presidents: HENRY B. DENHAM, M.B.; W. ERNEST MILES, F.R.C.S.; D. P. D. WILKIE, O.B.E., F.R.C.S.
Honorary Secretaries: CECIL W. ROWNTREE, F.R.C.S. 9, Upper Brook Street, London, W.1; HAMILTON DRUMMOND, F.R.C.S. Edin. (6, Saville Place, Newcastle-on-Tyne).

Thursday, July 21st.

DERMATOLOGY.

President: JOHN FARQUHAR CHRISTIE, M.A., M.B.
Vice-Presidents: ERNEST DORE, M.D., F.R.C.P.; ARTHUR D. HEATH, M.D., M.R.C.P.; D. WELLS PATTERSON, O.B.E., M.D., M.R.C.P.
Honorary Secretaries: WILLIAM JENKINS OLIVER, M.A., M.B. (58, Queen Anne Street, London, W.1); SYDNEY THOMPSON, M.B., B.S. 19, Windsor Terrace, Newcastle-on-Tyne.

The following provisional programme has been arranged:
July 21st (10 a.m.).—Discussions: (1) Cutaneous Sensitization and Focal Sepsis in the Etiology of certain Skin Affections. To be opened by H. W. BARBER, M.B.Camb., M.R.C.P. (2) The Association of Skin Tuberculosis with Visceral and other Tuberculous Manifestations. To be opened by GEORGE H. LANCASHIRE, M.D. (3) Dermatological Cases attending the Pensions Boards. To be opened by HENRY MACCORMAC, C.B.E., M.D. Edin., F.R.C.P. Lond. (with the permission of the Ministry of Pensions).

Friday, July 22nd.

MEDICAL SOCIOLOGY.

President: Sir JENNER VERRALL, LL.D., M.R.C.S.
Vice-Presidents: CHARLES BETTAR, M.A., M.D.; A. C. FARQUHARSON, M.D., M.P.; E. ROWLAND FOTHERGILL, M.B., B.S.
Honorary Secretaries: J. F. WALKER, M.B. (Rocklands, Clifton Terrace, Southend-on-Sea); MABEL G. BRODIE, M.B. (Maternity and Child Welfare Offices, 42, Old Elvet, Durham).

RADIOLOGY AND ELECTROTHERAPEUTICS.

President: ROBERT KNOX, M.D.
Vice-Presidents: W. HOPE FOWLER, F.R.C.S. Edin.; ROBERT EDWARD HOWELL, M.B., C.M.
Honorary Secretaries: JAMES METCALFE, M.D. 123, Harley Street, London, W.1; THOMAS LOWE BUNTING, M.D. (6, Portland Terrace, Newcastle-on-Tyne).

The following provisional programme has been arranged:
July 22nd (10 a.m.).—Discussion: On the Changes induced in Blood Constituents by Radiations: (a) Experimental evidence, Professor SIDNEY RUSS and Dr. ARCHIBALD LEITCH; (b) Clinical observations, Dr. MOTTRAM, Dr. GAMLEN, Dr. J. B. WATERS, Dr. METCALFE, Dr. HOPE FOWLER and others. On Morbid Conditions of the Blood: (1) The Anaemias, (2) Leukaemia, (3) Banti's disease, etc. Opening paper by Professor G. L. GULLAND, C.M.G. (Edinburgh). Discussion on

Surgical Diathermy, to be opened by Dr. CUMBERBATCH, followed by Dr. HOWARD HUMPHRIS, Dr. SABERTON and others. Exhibition of radiograms, etc., in the Pathological Museum. A visit will be paid to the x-ray and electro-therapeutic departments of the Royal Victoria Infirmary, Newcastle-upon-Tyne.

UROLOGY.

President: J. W. THOMSON WALKER, O.B.E., F.R.C.S.
Vice-Presidents: P. J. CAMMIDGE, M.D.; JOHN CLAY, C.B.E., F.R.C.S.; H. C. PEARSON, F.R.C.S. Ed.
Honorary Secretaries: SYDNEY G. MACDONALD, F.R.C.S. (51, Queen Anne Street, London, W.1); W. S. DICKIE, O.B.E., F.R.C.S. Ardenapeel, Southfield Road, Middlesbrough.

The following provisional programme has been arranged:
July 22nd (10 a.m.).—Discussion: The Diagnosis and Treatment of Cystitis. To be opened by J. F. DOBSON, M.S., F.R.C.S. (Surgical). Papers: Experimental Evidence bearing on the Source of the Amyolytic Ferment in the Urine, by P. J. CAMMIDGE, M.D.; Open Prostatectomy, by J. W. Thomson Walker, M.B., F.R.C.S.; Treatment of Bladder Growths, by Sydney G. MacDonald, M.B., F.R.C.S.

The Honorary Local General Secretary of the meeting is R. J. WILLAN, M.V.O., O.B.E., F.R.C.S., 6, Kensington Terrace, Newcastle-on-Tyne.

PROVISIONAL TIME TABLE.

The following is the provisional time table for the Newcastle-upon-Tyne Meeting, 1921:

	FRIDAY, JULY 15TH, 1921.
10 a.m.	Annual Representative Meeting.
	SATURDAY, JULY 16TH.
9.30 a.m.	Representative Meeting.
	MONDAY, JULY 18TH.
9.30 a.m.	Council Meeting.
11 a.m.	Representative Meeting.
	TUESDAY, JULY 19TH.
9.30 a.m.	Representative Meeting.
2 p.m.	Annual General Meeting.
5 p.m.	Religious Services.
8 p.m.	Adjourned General Meeting. President's Address.
	WEDNESDAY, JULY 20TH.
9 a.m.	Council Meeting.
10 a.m. to 1 p.m.	Sectional Meetings.
2 p.m.	Secretaries' Conference.
3 to 4.30 p.m.	Demonstrations.
6.30 p.m.	Secretaries' Dinner.
8 p.m.	Special Address on Industrial Medicine.
	THURSDAY, JULY 21ST.
10 a.m. to 1 p.m.	Sectional Meetings.
3 to 4.30 p.m.	Demonstrations.
7.30 p.m.	Annual Dinner.
	FRIDAY, JULY 22ND.
10 a.m. to 1 p.m.	Sectional Meetings.
3 to 4.30 p.m.	Demonstrations.
7.30 p.m.	Popular Lecture.
	SATURDAY, JULY 23RD.
	Excursions.

ACCOMMODATION AT NEWCASTLE.

Hotels.

A LIST of these was published in the SUPPLEMENT of May 7th. The Market, Clyde, and Norfolk are strictly commercial hotels. Doctors bringing their wives with them are advised to apply to the hotels heading the list, unless applying to the residential hotels for accommodation. It is suggested that two members attending the Annual Meeting might arrange to engage a room with two beds if they fail to obtain single rooms. The managers of the hotels have been informed that, in the event of one of the beds in the rooms with twin-beds being engaged by a member, the remaining bed must only be occupied by a member of the British Medical Association.

Members are again advised to make early application for rooms at Whitley Bay.

Lodgings.

The list of these is a small one. The scarcity of houses has driven many people into lodgings: thus a very large number were found when visited to be in permanent occupation. The landlords, too, showed an independence

which was somewhat trying. The committee therefore wishes to make the fullest use of hotel accommodation. A list of lodgings, however, is available, but it was felt that it would save much annoyance and correspondence if members desiring to stay in lodgings would communicate direct with the Honorary Secretary of the Hotels and Lodgings Committee, Dr. E. Farquhar Murray, 52, Jesmond Road, Newcastle-upon-Tyne, who will arrange for their accommodation.

The following points, if observed, will facilitate the work of allocation when application is made:

1. Engaging rooms for a week will be much easier than for a night or two. The majority of landlords want this, although a number state terms for a night.

2. The charges for bed and breakfast range from 6s. to 12s. 6d. The range, therefore, should be stated.

3. The number for whom accommodation is required should be stated, and whether medical men, medical women, or doctor and wife.

4. The majority of the landlords offer only bed and breakfast. It should be stated if more meals are required.

5. The exact dates of arrival and departure should be given.

6. When writing state if, failing accommodation being found in lodgings, the member would be agreeable to being put up in an hotel, hostel, or elsewhere.

Hostels.

Particulars of one Newcastle hostel were given in the SUPPLEMENT of May 7th. A number of the Durham hostels and colleges have been put at the disposal of the Association, but it has been decided not to take them over at present until an indication is given that a sufficient number of members wish to stay at Durham, or until the accommodation at Newcastle is fully taken up. Members who desire to reside at Durham during the meeting should write to the Local Representative, Dr. F. F. T. Harc, The Avenue, Durham, as early as possible, when the necessary accommodation will be provided.

Medical Women.

Those who propose to come to the meeting and have any difficulty in finding accommodation are requested to communicate with Dr. Ethel Williams, 3, Osborne Terrace, Newcastle-upon-Tyne, who is Chairman of the Lady Doctors' Subcommittee.

General Information.

The Honorary Secretary, Dr. E. F. Murray, will gladly give any information about accommodation to members who apply to him. No anxiety need be felt on the question of securing accommodation if members will only make arrangements in good time. There are abundant tea-rooms and restaurants in the town, and a list of these will be published before the meeting.

Association Notices.

REPRESENTATIVE MEETING.

DATE.

THE Annual Representative Meeting at Newcastle will begin on Friday, July 15th, 1921, at 10.0 a.m.

NOTICES OF MOTION AND AMENDMENT BY DIVISIONS AND BRANCHES.

The Supplementary Report of Council to the Representative Meeting will appear in the SUPPLEMENT of July 2nd, 1921.

Notices of Motion and Amendment by Divisions and Branches for consideration by the Annual Representative Meeting will be published in the SUPPLEMENT as they are received, but none can be published later than July 2nd, for which purpose they must be received by the Medical Secretary not later than the first post on Monday, June 27th.

It will be possible, however, to include in the Agenda for the Annual Representative Meeting all Notices of Motion and Amendment which are received by the Medical Secretary not later than the first post on Monday, July 4th, 1921.

ELECTION OF 24 MEMBERS OF COUNCIL BY BRANCHES IN UNITED KINGDOM.

The following is a list of the nominations received:

Group.	Branches in Group.	Candidates nominated.	No. of Seats.
A	North of England. North Lancashire and South Westmorland	Dr. JAMES DON (Newcastle-on-Tyne)	1
B	Yorkshire	Dr. A. FORBES (Sheffield)	1
C	Lancashire and Cheshire	Dr. T. W. H. GARSTANG (Altrincham) Mr. F. STRONG HEANEY (Liverpool) Dr. FRANK RADCLIFFE (Oldham)	2
D	East York and North Lincoln. Midland	Maj.-Gen. Sir R. H. LUCE, K.C.M.G., C.B. (Derby)	1
E	Cambridge and Huntingdon. Essex. Norfolk. South Midland. Suffolk.	Dr. E. O. TURNER (Great Missenden)	1
F	Birmingham Staffordshire	Dr. H. C. MACTIER, M.B.E. (Wolverhampton) Dr. A. W. NUTHALL (Birmingham)	1
G	North Wales. Shropshire and Mid Wales. South Wales and Monmouthshire	Dr. W. B. CRAWFORD TREASURE (Cardiff)	1
H	Metropolitan Counties	Dr. H. S. BEADLES (West Ham) Dr. C. BUTAR (Kensington) Lord DAWSON OF PENN, G.C.V.O., K.C.M.G. (Marylebone) Mr. N. BISHOP HARMAN (Marylebone) Dr. R. LANGDON DOWN (Hampton Wick) Dr. WM. PATERSON (Willesden)	4
I	Bath and Bristol Gloucestershire West Somerset Worcestershire and Herefordshire	Dr. H. C. BRISTOWE (Wroughton) Dr. A. O. HOLBECH (Worcester)	1
J	Dorset and West Hants. South-Western. Wiltshire	Mr. RUSSELL COOMBE (Exeter)	1
K	Oxford and Reading. Southern	Dr. D. A. SHEAHAN (Portsmouth)	1
L	Kent. Surrey. Sussex	Dr. E. ROWLAND FOTHERGILL (Hove) Dr. ARNOLD LYNDON (Hindhead)	1
M	Aberdeen. Dundee. Northern Counties. Perth	Dr. DAVID LAWSON (Banchoy)	1
N	Edinburgh. Fife	Dr. JOHN STEVENS (Edinburgh)	1
O	Glasgow and West of Scotland (4 City Divisions)	Dr. WM. SNODGRASS (Glasgow)	1
P	Border Counties. Glasgow and West of Scotland (5 County Divisions). Stirling	Dr. HUGH MILLER (Hamilton)	1
Q	Connaught. South-Eastern of Ireland	Dr. DENIS WALSH (Graiguen, Killeeny)	1
R	Leinster	Dr. R. C. PEACOCKE (Blackrock, Dublin)	1
S	Munster	Dr. PHILIP G. LEE (Cork)	1
T	Ulster	Mr. R. J. JOHNSTONE (Belfast)	1
			24

Voting papers for Groups C, F, H, I, and L will be posted from Head Office on Saturday, May 21st; they are returnable by Monday, June 6th, first post.

NOTICES OF MOTION BY DIVISIONS FOR THE ANNUAL REPRESENTATIVE MEETING, NEWCASTLE, 1921.

By BUCKINGHAMSHIRE DIVISION:

That reports of Division meetings should be published in full in the BRITISH MEDICAL JOURNAL SUPPLEMENT.

That this meeting approves of the idea of federation with other medical bodies, provided that the greatest care is taken to safeguard the interests of

the British Medical Association, especially with regard to its financial interests and medical policy.

That non-medical bodies should be excluded from a federation.

By Mr. McADAM ECCLES (Marylebone):

That the draft scheme prepared by the Metropolitan Counties Branch Council of an organization for London of a national provident scheme for hospital and additional medical services be approved by the Representative Body as conforming to the policy of the Association in regard to voluntary hospitals.

[NOTE.—This scheme was published in the SUPPLEMENT, April 30th, 1921, pp. 161-162.]

Meetings of Branches and Divisions.

SUSSEX BRANCH: CHICHESTER AND WORTHING DIVISION.

A MEETING of this Division was held at Chichester on April 27th, when Dr. David Ewart was in the chair. At the conclusion of the business agenda an interesting address was given by Dr. Robert Hutchison, physician to the London Hospital, on "The Diagnostic Significance of Abdominal Pain in the Adult." Many members took part in the ensuing discussion, and Dr. Hutchison replied. The meeting passed a cordial vote of thanks to the lecturer for his instructive address. Dr. Hutchison subsequently dined with the members, and a pleasant evening was spent. This is the third of a series of similar meetings held during this divisional year, and the practice of combining the pursuit of medical science with the cultivation of the social qualities has been a success.

MEETINGS TO BE HELD.

BIRMINGHAM BRANCH: CENTRAL DIVISION.—The annual meeting of the Central Division will be held at 18, Bennett's Hill, on Thursday, June 16th, at 3.45 p.m. Agenda: To instruct Representatives. To elect officers for ensuing year. Nominations for officers must be in the hands of the Honorary Secretaries fourteen days before the meeting. Members are requested to bring with them copies of the SUPPLEMENT of April 30th.

METROPOLITAN COUNTIES BRANCH.—The annual general meeting of the Metropolitan Counties Branch will be held at 429, Strand, W.C., on Friday, June 24th, at 4 p.m. Business: (1) Report of scrutineers as to the election of new officers. (2) Annual Report of Council. (3) Alteration in Rule 11 by the insertion of words providing that such members of the Branch as are members of the Central Council shall be *ex officio* members of the Metropolitan Counties Branch Council. (4) President's address by Dr. H. B. Brackenbury: The Psychologist in Public Life.

METROPOLITAN COUNTIES BRANCH: CITY DIVISION.—The annual general meeting of the City Division will be held at the Metropolitan Hospital on Friday, May 27th, at 9 p.m. Agenda: (1) Election of officers and Representatives for ensuing year. (2) Instructions to Representatives. (3) 10 p.m., Address by Dr. H. B. Brackenbury, Vice-President of Branch and President-elect of Branch. Dr. Brackenbury will explain the National Provident Scheme for hospital and additional medical services. As this is likely to affect the general practitioner very closely, it is hoped that everyone will make a special effort to be present. It is particularly to be desired that as many members as possible who are resident in the Islington section shall attend. It is proposed during the next session to hold several of the meetings, both clinical and ordinary, in the Islington area. During the session 1921-22 there will be a dinner entertainment (on November 3rd) and three dinner dances. Monthly lectures will be given; the first, in October, being a dental lecture, with lantern slides, by Dr. C. E. Wallis.

METROPOLITAN COUNTIES BRANCH: LEWISHAM DIVISION.—A meeting of the Division will be held on Tuesday, May 24th, at 8.30 p.m., at St. George's Lodge, Catford, S.E.6. Agenda: Discussion of the provident scheme for hospitals in London area. Any other business.

MIDLAND BRANCH: KESTIVEN DIVISION.—The annual meeting of the Division will be held at Dr. T. P. Greenwood's residence, 36, St. Mary's Street, Stamford, on Tuesday, May 31st, at 3.30 p.m. Business: (1) To elect the Chairman and Committee for the ensuing year. (2) To elect a Representative in Representative Body. For the purpose of this election, this meeting is a joint meeting of the Kestiven and Holland Divisions. (3) To discuss the agenda for the Annual Representative Meeting, and to instruct the Representative thereon. The honorary secretary, Dr. C. H. D. Robbs, informs members that he has obtained authority from the bodies concerned, throughout the Division, for the fees paid to medical practitioners called in by the police to be: day call, 7s. 6d.; night call, 10s. 6d. Tea will be provided at the conclusion of the meeting, and it is hoped that objects of interest in Stamford may be viewed.

SOUTH-WESTERN BRANCH: EXETER DIVISION.—The annual meeting of the Division will be held in the library of the Royal Devon and Exeter Hospital, on Thursday, May 26th, at 3 p.m. Tea will be provided. Agenda: Report of Executive Committee. Election of officers and representatives. Consider Annual Report of Council.

YORKSHIRE BRANCH: SHEFFIELD DIVISION.—The annual meeting of the Division will be held at the Church House, St. James Street, Sheffield, on Friday, May 27th, at 8.30 p.m., when the report of the Executive Committee will be presented and the officers and committee elected for the ensuing year.

SCOTTISH CONSULTATIVE COUNCIL'S REPORT.

VIEWS OF THE ROYAL COLLEGE OF PHYSICIANS OF EDINBURGH.

THE Royal College of Physicians of Edinburgh at its last quarterly meeting adopted the following report of a Committee of the College regarding the Interim Report submitted by the Consultative Council on Medical and Allied Services to the Scottish Board of Health:

In reviewing the Interim Report of the Consultative Council on Medical and Allied Services the Committee of the College have kept in view the terms of the reference from the Board of Health to the Consultative Council, as follows:

"To consider and to make recommendations as to the systematized provision of such form of medical and allied service as should, in the opinion of the Council, be available for the community."

The reference raises two issues which, although closely related, may with advantage be considered separately—namely: (1) What forms of medical and allied services should be available for the community? (2) How best can the provision of such services be systematized?

(1) What forms of medical and allied services should be available for the community? The Committee of the College are in accord with the view of the Consultative Council that the present provision of such services throughout the community is inadequate and patchy. Hiatuses and irregularities exist which call for careful consideration.

The Committee note with satisfaction the definite recognition of the home and the household as the primary centre of medical care. From the medical as well as from the social point of view the family is the normal unit. If the health of the nation is to be placed on a high level, the home must be the centre of medical endeavour, both preventive and curative. The family doctor, in immediate relation with the individual household, must be the instrument and agent of any scheme for the systematized provision of medical and allied services. Households should be encouraged to look to the family doctor as their normal medical adviser and guardian, to whom they naturally refer all matters pertaining to health, and who personally renders such services as he can, and likewise sees that auxiliary services otherwise provided are suitable and sufficiently brought within their reach.

It is, in the opinion of the Committee of the College, a primary and essential condition in the provision of extra medical services that the family doctor should be the medium of communication and arrangement in the case of households which are normally under his care. Only in this way can the continuous attention of the doctor to the well-being of the household be maintained and the interest of the community secured. Divorced from the family doctor as the ultimate health agent, attempts at the systematic provision of medical services are, in the judgement of the Committee, doomed to failure.

If the premiss be conceded the way is clear to a useful consideration of the directions in which the efforts of the individual doctor may properly be supplemented by extra services duly systematized.

Provision for such extra services has already been made in certain directions, but in piecemeal and unequal fashion. In connexion with some of these it may fairly be questioned if sufficient care has been taken to secure the friendly concurrence and co-operation of the family doctor in the way which seems to the Committee essential for success. Obvious examples of the lack of proper co-ordination are to be found in connexion with the education medical services and child welfare and maternity schemes.

Such agencies affect the health of family life and their operation can only be successful when intimately linked with those of the family adviser. It is most desirable that any machinery for the betterment of the community erected outside the individual home should be brought into intimate relationship with the operation of the doctor within the home. The doctor should be a party to all communications and measures proposed in the interest of the members of the household. No one knows better than the family doctor the lacunae which exist in his

* "A Medical Service Scheme for Scotland," BRITISH MEDICAL JOURNAL, December 11th, 1920, p. 900.

armamentarium for the suitable treatment of various patients at varying stages of illness, nor will anyone be more appreciative of sound proposals whereby the deficiencies can be made good.

The Committee of the College are unanimously of opinion that the facilities presently available for the care and treatment of sick persons throughout the country call for improvement and expansion in numerous directions. They recognize that existing needs differ somewhat in different parts of the country. The needs of a densely populated centre of industrial life are different from those of a scattered rural area. In this respect the needs of the Highlands and Islands call for particular consideration.

The recommendations of the Consultative Council are evidently based on a careful review of the available evidence. The Committee of the College have gone over the recommendations in detail and are generally in agreement with the proposals, provided that the relation of the family doctor to the extra medical services be safeguarded, and that certain conditions as to the mode of provision and systematization of such services be fulfilled.

The Committee of the College desire to reinforce the position that a great improvement might be effected in relation to the immediate treatment of illness and to the prevention of disease by a thoroughgoing reform of housing conditions, and particularly by the education of the inmates as to how to make the best use of the dwelling house.

The Committee approve of the recommendation of the Council that certain services involving special skill or equipment, which are essential for successful medical treatment, and are at present beyond the reach of certain classes of the community, should be made available to all. In this sense the Committee approve of the suggested provision of special accommodation for cases of illness, either acute or chronic, which, while not requiring special surgical or other skill, cannot in the judgement of the doctor be adequately treated in the patient's own home. This arrangement would have the added advantage of facilitating the work of sick nursing.

While really serious surgical cases would for the most part continue to be sent for operation to hospitals or homes, it seems right that supplementary professional advice and assistance should be made available to doctors in connexion with graver cases of illness occurring in their practice and continuing under their care. Some scheme for the simplification and facilitation of medical and surgical consultation throughout the country is most desirable. It seems unnecessary at this stage to enter into detailed consideration of the proposed plan. In the opinion of the Committee this may safely be left to gradual development along natural lines, according to the needs and possibilities of the several areas.

The Committee are in hearty agreement with the Council's recommendation in favour of the provision of adequate laboratory facilities, and especially the bringing of these more uniformly within easy reach of practitioners throughout the country. It seems natural that in some areas such facilities might be associated with local clinics. Here also the detailed scheme outlined in the report must evidently be a matter of gradual development.

The Committee are unanimously in favour of the extension of the principle of convalescent homes in connexion with the hospitals of the country. This would notably ease the strain on hospital accommodation, and obviate the many disadvantages presently attaching to the system of waiting lists, which seriously limit the value of the larger hospitals. Apart from the needs of hospitals, it would be an immense boon to the general practitioner to have more closely at his service convalescent homes for the behoof of persons recovering from serious illness involving long convalescence. Much may be said likewise for the provision of country rest homes to which persons suffering from the strain of work, or other cause, might be sent with a view to anticipate illness or prevent more serious breakdown.

No argument is needed to enforce the value to the patient and to the doctor as to the extension of the methods of district nursing. The Queen Victoria Jubilee Nurses' Organization has brought incalculable benefit to the community, and the voice of the profession is unanimous in pressing for a still larger development along such lines. What the rich can afford for themselves in this direction should be made available to all. No greater immediate service could be rendered to the country by the Board of Health than the placing of the Queen Victoria Jubilee Organization on a larger and more stable basis. The proposal for an elaborate service of health visitors, apart from such nurses, is little favoured by the Committee. The experience of a good many members of the Committee

is strongly adverse to the methods of this service as hitherto developed. The Committee are unanimously of opinion that health visitors should in all cases have enjoyed nursing training.

With regard to maternity, the Committee favour the view that provision must be made whereby skilled medical guidance is available for every expectant mother. For the most part this should be attained by way of the family doctor, who in many directions may be the means of ensuring safe gestation and anticipating trouble. The doctor would be suitably aided by a service of midwives who may frequently, in cases of normal labour, replace the doctor. In view of the occurrence of difficult cases, or where the home is obviously unsuitable, it is desirable that a sufficient number of maternity beds should be available in every district.

The Committee concur in the Council's recommendation that adequate facilities should exist throughout the country for conservative dentistry.

(2) Assuming that an expansion of medical and allied services such as has been outlined should be afforded, a further question arises as to the method whereby the services should be made available. How best can the provision of such services be systematized? The Committee would remind the College that the Board of Health, as now constituted, represents the centre of co-ordination for purposes of direction and administration of all the public services and agencies concerned with the health of the community.

The College has on various occasions urged the desirability of a complete and systematized centralization of health activities. The Consultative Council on Medical and Allied Services, whose interim report is now under consideration, is an important auxiliary of the Board. The College gave its concurrence to the constitution of the Council by recommending certain persons for inclusion in its membership.

Whatever conclusions the Board of Health may come to after consideration of the views of the Consultative Council, and of other bodies who may volunteer suggestions as to the policy to be followed in the interest of the health of the community, it is obvious that a successful issue will chiefly depend on the just adaptation and smooth running of the machinery whereby the policy is put into practice throughout the country.

If such co-ordination of services and agencies be essential at the centre, similar co-ordination is no less necessary throughout the country, and particularly at the periphery. The Committee of the College cordially endorse the plea of the Consultative Council in pressing for a unification of the various local authorities concerned with health and treatment in each district. Such unification is the first step towards a successful systematization of medical services.

Locally as well as centrally the various agencies concerned with the direction and maintenance of health services must be closely linked up. The question whether this should be effected by enlargement of the presently existing Health Committees of local authorities so as to include in their membership a larger proportion of competent persons—by reason of training and experience—or by the creation of a special local authority—erected *ad hoc*—hardly rises for consideration here. The Committee would, however, emphasize the opinion that ultimately the success of the Board of Health's policy will largely depend on the extent to which the policy embodies the principle that the health service of the nation, however elaborated, should be based on the family doctor as the medical attendant and guardian of the household, and that, whatever extra services are provided, should be conceived as supplemental and auxiliary to his efforts.

In endorsing the above recommendations made by the Consultative Council the Committee of the College would not have it supposed that they look for the immediate realization of the details outlined in the scheme of medical services proposed in the report. The present economic condition of the country makes this manifestly impossible. It is, in their opinion, none the less important that a beginning be made and sound foundations laid for the gradual development later as circumstances may permit.

Lastly, in relation to financial considerations which hardly come within the terms of the reference, it seems pretty clear to the Committee that, while the wealthier classes can already attain most of the advantages which are now claimed for all, it will be found that for a certain section of the community, fairly described as necessitous, the provision of all medical service will have to be made at the public expense. It seems no less clear that the costs of medical services as expanded in the way that has been outlined—which will be necessarily considerable—

might, for a large intermediate group between the wealthy and the necessitous, be met by a scheme of graded contribution either voluntary or enforced by statute.

The Committee think it proper to add that some members of the Committee, in adhering to the Committee's report, object to an extension of medical benefits under the National Health Insurance Acts to dependants of the insured population except on a basis of voluntary contribution, while some desire to place on record their continued disapproval of the conditions of service under the medical benefit section of the National Health Insurance Acts.

Correspondence.

A Medical Service Scheme for Scotland.

SIR,—On January 25th last the Medical Guild addressed a letter to the medical profession in Scotland with an accompanying memorandum, both of which adversely criticized the Interim Report on a Scheme of Medical Service for Scotland presented to the Scottish Board of Health by the Consultative Council on Medical and Allied Services. These communications were published in the *Scotsman* on the following day. The "Summary of Recommendations" taken verbatim from the interim report was annexed to the letter.

The letter contained the following questions to which answers were invited: (1) Do you approve of the terms of this letter and memorandum? (2) Do you approve of the proposed extension of National Health Insurance (Recommendation 4)?

We are now in a position to announce the result of this referendum, which is of equal importance to the general public and the medical profession. Question 1 referred to the letter and memorandum of the Guild, whose attitude is expressed in the memorandum thus: "Matters will be righted only when the State ceases to interfere with medical attendance on sick people other than those who belong to the necessitous classes, so long as the sick are not a danger to the community by reason of infectivity." Question 2 requires no elaboration. Replies favourable to the policy of the Guild required "Yes" for Question 1 and "No" for Question 2.

The returns so far: total number 1,331. Of that number, 1,105, or approximately 83 per cent., voted "Yes" to Question 1 and "No" to Question 2; 165, or approximately 12½ per cent., answered both questions in the negative; the remaining 61, less than 5 per cent., voted "No" for Question 1 and "Yes" for Question 2, and thus this small minority only were in favour of the recommendations of the Consultative Council. The large majority, 1,270 (that is, 1,105 plus 165), over 95 per cent. of the total vote, were therefore opposed to further extension of the National Health Insurance Act, which is made the basis of the Consultative Council's scheme. In many cases replies were accompanied by emphatic protests against the nationalization of the practice of medicine, notably from men who have had ample experience of work under a State Medical Service similar in outline to the scheme proposed by the Consultative Council.

It is difficult to give an accurate statement of the number of men at present serving under the National Insurance Act who voted with the above large majority, but the returns received from certain working-class districts prove that the proportion was large.

The result of this referendum demonstrates that a large section of the profession in Scotland is opposed to the provision for medical services recommended in the interim report, including the extension of the National Health Insurance Act.

It will be remembered that the Consultative Council consider co-operation of the medical profession to be essential for the success of this scheme. The above results clearly indicate that this will not be obtained. On the contrary, it is evident that the profession would support a medical service limited to those who are unable to make provision for themselves. This would restrict the large and increasing national expenditure on medical practice, and would in no way interfere with the national health.—We are, etc.,

FRANCIS M. CAIRD,
President.

FREDERICK PORTER,
Honorary Secretary.

The Medical Guild, Edinburgh,
May 12th.

Insurance Renunciation.

SIR,—I notice in the address delivered by Dr. Alfred Cox to the Leeds Division of the British Medical Association he alluded to the possibility of a demand being made in

the near future for a reduction of the National Insurance capitation fee to the doctors.

Now, Sir, I for one consider that such a demand would be preposterous, and I am quite sure that the great majority of panel practitioners would be of my way of thinking. Why should such a demand be made? We have only had the increased fee for fifteen months, while many other workers have had a rise for years, and not one rise only. What does our rise amount to? The fee was increased from 7s. to 11s.—just 57 per cent.—while the increase in some workers' wages was over 200 per cent. It will be time enough to talk of reduction when the cost of living is reduced to about 60 per cent. over pre-war figures. At present I believe the increase is 133 per cent.

The BRITISH MEDICAL JOURNAL has fought for and obtained in a great number of cases increases to wholesale medical officers of 50 per cent. and over. It is not suggested (and quite rightly so) that their salaries should be reduced at present, yet they are in a much more comfortable position than panel practitioners, as they have fixed hours and no night work, while a panel practitioner cannot call his soul (or body) his own, as he is always expected to be on duty. The chemists who take service under the Insurance Act take good care that they are not always at the beck and call of insured persons.

When the question of a State Medical Service was being talked about some time ago, one of the advantages I saw in it was that we medical men would have a very good case for demanding an eight hours day. We might then be able to carry on in the calm "go-as-you-please" fashion of a Government office instead of struggling to keep up with our work (including the keeping of records) and wearing the flesh off our bones in the endeavour to decide whether we should notify a case of scarlet or enteric fever and receive for our trouble the magnificent fee of one shilling. By the way, are we still at war with Turkey? If so why so, and if not, why is not the notification fee raised to half a crown? Yet M.P.'s grant themselves free first class railway tickets and propose to raise their own salaries.

There is a very widespread impression in the profession that the Insurance Acts Committee of the British Medical Association do not stand up to the Government as they might, and unless this impression is removed it will act prejudicially on the Association. When I use the word "profession" I mean those of us who are in general practice, and more particularly those of us who are panel practitioners.

While saying this I would at the same time earnestly appeal to all medical men to join the British Medical Association, which is far and away the largest body of medical men. Do not be selfish; do not say "What benefit shall I reap by joining the Association?" If you receive no personal benefit remember that you are helping many of your brother chips. If you are dissatisfied with the present conduct of affairs it is all the more necessary that you should join and make your point of view felt in the meetings, both local and general, of the Association. Many men who take no active part in the work are those who are most ready to criticize, and yet they receive the same advantages as those who have fought for it, and who have borne the burden and heat of the day.

I am, etc.,

PHILIP LAMBERT BENSON,

Steeple Claydon, Bucks, May 12th.

INSURANCE.

MEETING OF BUCKINGHAMSHIRE INSURANCE PRACTITIONERS.

A GENERAL meeting of the insurance practitioners of the Buckinghamshire panel was held at the Royal Buckinghamshire Hospital on April 29th, when Dr. BELL was in the chair.

Dr. BELL briefly introduced Dr. BONTOR, the regional medical officer, who then gave detailed advice as to the filling up the new record cards, the procedure adopted when a second opinion was required, the filling up of certificates and other matters. He stated that he wished to help the doctors and to make their path as smooth as possible. At the conclusion of this useful address questions were invited and many points were dealt with that were not very clear in the instructions. The greatest trouble experienced by the doctors was said to be in regard to their keeping correct lists of insured persons. It was quite impossible to do so under the present system, and much time was lost in searching for record cards that were not sent, searching for record cards when pink slips were sent and not finding them, finding men's names entered on women's cards, sending in new medical cards and not getting a record card in return, the small number of window envelopes supplied, the case of the men over 70 years of age who are liable to be overlooked, enlisted men who have returned and not taken the trouble to get a new card, etc.

Finally the following resolution was directed to be sent to the Ministry of Health:

"That this general meeting of the practitioners on the Buckinghamshire panel wishes to express its great dissatisfaction at the state of chaos which exists in the keeping of the lists of insured persons by the Insurance Committee of this county. The record cards issued to practitioners are very incomplete, causing much extra work and great exasperation among practitioners."

A hearty vote of thanks was accorded to Dr. Bontor, and the meeting concluded after partaking of tea kindly prepared by the matron of the hospital.

A meeting of the Local Medical and Panel Committee was held on the same day at the Royal Buckinghamshire Hospital, with Dr. BELL in the chair. Dr. DICKSON reported that friendly societies were making arrangements for the nursing of their members. It was reported that a doctor had been fined £10 for a breach of the certification rules. The revised terms with chemists were agreed to. Consideration was given to the letter from the Ministry of Health (SUPPLEMENT, April 16th, 1921) dealing with anaesthetists' fees, wherein a new form of claim was suggested (G.P. 19), and in which the practitioner performing the operation declares it to be within his terms of service. It was thought to be very unwise to adopt this, and to be far better to adhere to the decision that the Panel Committee should decide this matter.

Mileage Scheme.—Correspondence was produced from adjoining areas as to the method of making mileage claims. In some districts the medical cards were marked with the distance and the lists compiled at the office. It was carried: "That in future years some method of making lists of mileage claims at the insurance office should be urged."

Surgery Notices.—It was decided to have five hundred notice forms for practitioners to put up in their surgeries giving notice that medical cards must be produced when coming for treatment or a fee would be charged.

Naval and Military Appointments.

ROYAL NAVAL MEDICAL SERVICE.

ROYAL NAVAL VOLUNTEER RESERVE.

Surgeon Lieutenants promoted to Surgeon Lieutenant Commanders: J. Lorrimer, L. C. D. Irvine, N. L. L. Rollason, B. Cohen, A. G. V. Elder, D.S.C., A. G. L. Reade, O.B.E., D. J. Williamson, W. C. Macartney, W. G. Evans, J. H. Lamb, E. F. Murray.

ARMY MEDICAL SERVICE.

Colonels H. N. Dunn, C.M.G., D.S.O. (late R.A.M.C.), and H. J. M. Euist, C.B., C.M.G., D.S.O., retire on retired pay.

ROYAL ARMY MEDICAL CORPS.

Major S. McK. Saunders is restored to the establishment. Captains G. K. Maurice, D.S.O., M.C., and D. W. Pailthorpe are seconded for service with the Egyptian Army. Captain A. W. Beavis retires, receiving a gratuity. Temporary Captains relinquish their commissions and retain the rank of Captain: T. M. Richardson, V. H. L. MacSwiney.

ROYAL AIR FORCE.

MEDICAL BRANCH.

T. P. Harpur is granted a temporary commission as Flying Officer with effect from and seniority April 19th.

DEFENCE FORCE.

ARMY MEDICAL SERVICE.

R.A.M.C.—To be temporary Majors: J. M. Cowan, W. Haig. To be temporary Captains: R. Morshhead, M.C., A. G. Williams, J. M. Christie, A. H. D. Smith, M.C., D. C. Graham, V. T. W. Eagles, M.C., A. E. H. Reid. To be temporary Lieutenants: A. N. Rushworth, J. E. Sinclair, E. H. Mayhew.

DIARY OF SOCIETIES AND LECTURES.

LONDON DERMATOLOGICAL SOCIETY, 49, Leicester Square, W.C.—Tues., 4.30 p.m., Pathological Specimens and Cases.

MEDICAL SOCIETY OF LONDON, 11, Chandos Street, W.1.—Mon., 8 p.m., Annual General Meeting, Election of Officers and Council for 1921-1922 Session; 9 p.m., The Annual Oration by Lord Dawson of Penn, K.C.V.O., on The Colon and Colitis, followed by a *Conversazione*.

MEDICO-LEGAL SOCIETY, 11, Chandos Street, W.1.—Tues., 8.30 p.m., Mr. W. G. H. Cook, LL.D.: The Liability of the Insane in respect of Civil Wrongs.

ROYAL SOCIETY OF MEDICINE.—Tues., 5 p.m. General Meeting of Fellows. *Section of Odontology*: Mon., 8 p.m., Annual General Meeting. Mr. J. H. Mummery and Mr. G. J. Harborow: A Composite Odontome. Mr. A. T. Pitts: Prophylactic Extraction of Third Molars. *Section of Medicine*: Tues., 5.30 p.m., Annual General Meeting. Discussion: Artificial Pneumothorax, to be opened by Dr. Clive Riviere. The following will also take part: Dr. S. Vere Pearson, Dr. Neville Cox, Dr. Donald Hall, Dr. Jane Walker, Dr. C. S. Burrell. *Section of Urology*: Thurs., 3.30 p.m., St. Thomas's Hospital, Operations by Mr. Cyril Niteh; 8.30 p.m., (1, Wimpole Street, W.1), Annual General Meeting. Mr. V. Zachary Cope: Genito-urinary Symptoms in Acute Appendicitis. Demonstration of a New Operating Cystoscope by Mr. Swift Joly. *Section of Study of Disease in Children*: Fri. (4.30 p.m., Cases), 5 p.m., Annual General Meeting. Dr. Hugh Thurshfield: Diagnosis of Renal Calculus in a Child. *Section of Epidemiology and State Medicine*: Fri., 8.30 p.m., Annual General Meeting. Dr. R. J. Reece: Occurrence of Cow-pox and Human Cases in connexion therewith. Dr. F. R. Blaxall: Preparation of Vaccine Lymph at the Government Lymph Laboratory.

POST-GRADUATE COURSES AND LECTURES.

GLASGOW POST-GRADUATE MEDICAL ASSOCIATION, Western Infirmary (Electrical Department).—Wed., 4.15 p.m., Dr. J. R. Riddell: X Rays, etc.

INSTITUTE OF PATHOLOGY AND RESEARCH, St. Mary's Hospital, Paddington, W. Thurs., 4.30 p.m., Dr. J. A. Murray: Aims and Progress of the Experimental Study of Cancer.

LONDON HOSPITAL MEDICAL COLLEGE.—Mon., 5 p.m., Dr. W. M. Feldman: Ante-natal and Post-natal Child Physiology; Tues. and Fri., 5.15 p.m., Dr. M. Culpin: Psycho-neuroses.

MANCHESTER ROYAL INFIRMARY.—Tues., 4.30 p.m., Mr. J. W. Smith: Diagnosis of Rectal Conditions.

NATIONAL HOSPITAL FOR THE PARALYSED AND EPILEPTIC, Queen Square, W.C.—Mon., Tues., Thurs., Fri., 2 p.m., Out-patient Clinics; Tues., 3.30 p.m., Dr. J. Taylor: Demonstration of Cases. *Lectures*, 3.30 p.m., Mon., Dr. A. Turner. Neuroses; Wed., Mr. Leslie Paton: Ocular Palsies; Thurs., Mr. Scott: Vertigo; Fri., Dr. G. Stewart: Sciatic Nerve Lesions.

QUEEN'S HOSPITAL FOR CHILDREN, Hackney Road, E.—Mon., 4 p.m., Mr. M. Vlasto: Tonsils and Adenoids in Children; Tues., 4 p.m., Mr. A. H. Todd: Common Disabilities of the Lower Limbs (other than paralytic) in Children; Wed., 4 p.m., Dr. G. Bourne: Heart Disease in Children; Thurs., 12 noon, Mr. V. Nesfield: Corneal Opacities.

WEST LONDON POST-GRADUATE COLLEGE, Hammersmith, W.—Daily, 10 a.m., Ward Visits; 2 p.m., In- and Out-patient Clinics and Operations. *Lectures*, 5 p.m., Mon., Dr. A. Saunders: Gastric Disorders in Infants; Tues., Mr. Bishop Harman: Blind and Partly Blind Children; Wed., Dr. G. Stewart: Cranial Nerve Palsies; Thurs., Dr. L. S. Burrell: Artificial Pneumothorax; Fri., Sir R. Armstrong-Jones: Common Forms of Mental Diseases.

British Medical Association.

OFFICES AND LIBRARY, 429, STRAND, LONDON, W.C.2.

Reference and Lending Library.

THE READING ROOM, in which books of reference, periodicals, and standard works can be consulted, is open to members from 10 a.m. to 6.30 p.m., Saturdays 10 to 2.

LENDING LIBRARY: Members are entitled to borrow books, including current medical works; they will be forwarded, if desired, on application to the Librarian, accompanied by 1s. for each volume for postage and packing.

Departments.

SUBSCRIPTIONS AND ADVERTISEMENTS (Financial Secretary and Business Manager, Telegrams: Articulate, Westrand, London). MEDICAL SECRETARY (Telegrams: Mediseera, Westrand, London). EDITOR, *British Medical Journal* (Telegrams: Aitiology, Westrand, London). Telephone number for all Departments: Gerrard 2630 (3 lines).

SCOTTISH MEDICAL SECRETARY: 6, Rutland Square, Edinburgh. (Telegrams: Associate, Edinburgh. Tel.: 4361 Central.) IRISH MEDICAL SECRETARY: 16, South Frederick Street, Dublin. (Telegrams: Bacillus, Dublin. Tel.: 4737 Dublin.)

Diary of the Association.

MAY.

- 24 Tues. Lewisham Division, St. George's Lodge, Catford, S.E.6 8.30 p.m.
26 Thurs. London: Insurance Acts Committee, 2.30 p.m. Exeter Division, Annual Meeting, Royal Devon and Exeter Hospital, 5 p.m.
27 Fri. City Division, Annual Meeting, Metropolitan Hospital, 9 p.m. Address by Dr. H. B. Brackenbury, 1) p.m. Sheffield Division Annual Meeting, Church House, St. James Street, Sheffield, 8.30 p.m.
31 Tues. Kesteven Division Annual Meeting, 36, St. Mary's Street, Stamford, 3.30 p.m.

JUNE.

- 1 Wed. London: Medico-Political Committee, 2.30 p.m.
16 Thurs. Central Division, Annual Meeting, 18, Bennett's Hill, 3.45 p.m.
24 Fri. Metropolitan Counties Branch Annual Meeting, 429, Strand, W.C.2, 4 p.m.

APPOINTMENTS.

COATES, Vincent M., M.R.C.S., L.R.C.P. Lond., Honorary Assistant Physician to the Royal United Hospital, Bath.
FIRMAN-EDWARDS, L., B.A., M.B., B.Ch. Cantab., Honorary Pathologist to the Royal Isle of Wight County Hospital, Ryde.
KENNON, Robert, M.C., M.D., F.R.C.S., Honorary Assistant Surgeon to the Liverpool Royal Infirmary.
NICHOLSON, Ruth, M.B., B.S. Dunelm., Honorary Assistant Surgeon to the Liverpool Maternity Hospital and Ladies' Charity.
PAUL, Hugh, M.B., B.Ch. Belfast, D.P.H. Cardiff, Assistant Medical Officer of Health and Assistant Tuberculosis Officer, Oldham (Lancs.).
SUMNER, S. S., M.B., Ch.B., Senior House-Surgeon to the Darlington General Hospital.

BIRTHS, MARRIAGES, AND DEATHS.

The charge for inserting announcements of Births, Marriages, and Deaths is 9s., which sum should be forwarded with the notice not later than the first post on Tuesday morning, in order to ensure insertion in the current issue.

BIRTH.

SAYERS.—On May 16th, at Bushey Lodge, Teddington, to Dorothy and Patrick Sayers, M.R.C.S., L.R.C.P., a son.

SUPPLEMENT

TO THE

BRITISH MEDICAL JOURNAL.

LONDON: SATURDAY, MAY 28th, 1921.

CONTENTS.

	PAGE		PAGE
BRITISH MEDICAL ASSOCIATION.		GENERAL MEDICAL COUNCIL:	
CURRENT NOTES:		PRESIDENT'S ADDRESS	193
NEW SOUTH WALES BRANCH	197	ELECTION OF COMMITTEES	201
"THE BUFF BOOK"	197	FINANCE	201
COUNCIL ELECTION	197	CORRESPONDENCE:	
MEETINGS OF BRANCHES AND DIVISIONS	198	DR. MACDONALD'S MISSION TO SOUTH AFRICA	202
MEETINGS TO BE HELD...	198	ANAESTHETISTS' FEES IN INSURANCE PRACTICE	202
ASSOCIATION NOTICES	199	ELECTION OF PANEL COMMITTEES	202
SCHOLARSHIPS AND GRANTS IN AID OF SCIENTIFIC		NATIONAL HEALTH AND THE PRACTITIONER	203
RESEARCH	203	INSURANCE:	
ASSOCIATION INTELLIGENCE	204	COVENTRY PANEL AND LOCAL MEDICAL COMMITTEE	203
INSURANCE PRACTITIONERS AND TUBERCULOSIS		DIARY OF SOCIETIES AND LECTURES	204
REPORTS: MEMORANDUM BY THE MINISTRY OF HEALTH.	201	APPOINTMENTS...	204
NAVAL AND MILITARY APPOINTMENTS...	203	BIRTHS, MARRIAGES, AND DEATHS	204

British Medical Association.

CURRENT NOTES.

New South Wales Branch.

THE annual report of the Council of the New South Wales Branch of the Association states that the membership of the Branch is now 1,180. A conference was held in December, 1920, between the Council and accredited representatives of the friendly society lodges, who had requested that the income limits of lodge members receiving medical benefit should be increased, on the ground of the depreciation in the value of money. The question was raised by the Association of a correlative increase in remuneration for medical officers, based on the same decrease in the value of money and a corresponding rise in the cost of giving medical attendance. As a result of the conference both the prescribed income limits of lodge members and the rates payable for medical attendance were increased. On the occasion of the visit of the Prince of Wales to New South Wales last summer an arch of welcome was erected by the Association, as one of the public bodies of the State, in College Street, Sydney. A description of the arch was given in the *BRITISH MEDICAL JOURNAL* of October 16th, 1920. Very careful consideration was given to the annual report of the Council of the British Medical Association in regard to the question of the possibility and desirability of taking further powers under the constitution of the Association whereby it might become in part a federation of medical bodies, and approval was given at an extraordinary general meeting of the Branch in October, 1920, to a proposal made by the Federal Committee that a representative of the Branches in Australia should be sent to England to attend the conference to be held next July at the Annual Meeting at Newcastle-on-Tyne.

"The Buff Book."

It may be remembered that in the *JOURNAL* of August 28th, 1920, a note appeared under the heading "A Classified Directory," with reference to a proposed publication, "The Buff Book," of which a circular had been issued by a firm styled the Business Telephone Directories Limited. The Central Ethical Committee of the British Medical Association considered that the insertion of a medical practitioner's name in this publication would be objectionable from two points of view. In the first place, the circular made it plain that only selected names would be

published in the directory, to the exclusion of others, for no medical practitioner's name (with address and telephone number) would appear in the "Buff Book" unless he paid a minimum fee of 1 guinea. The second objection arose in connexion with the specimens of type at varying prices, shown in the circular. The first issue of the "Buff Book," dated October, 1920, contained the names of a few medical practitioners grouped under such headings as Physicians (consulting), Surgeons, Surgeons (ophthalmic), and Doctors. In the SUPPLEMENT of March 19th, 1921, further mention was made of this directory, with particular reference to a resolution passed by the Executive Committee of the General Medical Council on February 21st, confirming the opinion already expressed by the Central Ethical Committee of the British Medical Association. The resolution was as follows:

That the Executive Committee is of opinion that the insertion of the name of a medical practitioner for payment, whether with or without typographical display, in a list issued to the public, and purporting to be a list of local medical practitioners, which is not open to the whole of the profession without such payment, is not in accordance with the professional standards in respect of advertising, and might be held to bring a practitioner so advertising himself within the terms of No. 5 of the Council's Warning Notices.

A second edition of the "Buff Book," dated April, 1921, has now appeared. On the title-page it is described as a "Classified Commercial Telephone Directory for London." It contains, under the heading "Physicians and Surgeons," some seventy-two medical names, and under the heading "Surgeons" the names of ten practitioners. There are in addition the names of three consulting physicians and one consulting surgeon, one cardiologist and one laryngologist, aurist, and rhinologist. From a communication addressed to the British Medical Association by the proprietors of the "Buff Book," it appears that such medical names as were published in the last edition of this directory were inserted therein without charge. This does not remove the Central Ethical Committee's objection to the publication of a selected list of medical practitioners.

Council Election.

Dr. Frank Radcliffe, Oldham, having withdrawn his candidature, the two remaining candidates, Dr. T. W. H. Garstang (Altrincham) and Mr. F. Strong Heaney (Liverpool), are returned unopposed to the Council for 1921-22 as the representatives of the Lancashire and Cheshire Branch. No voting papers have therefore been issued in connexion with this Group.

Meetings of Branches and Divisions.

YORKSHIRE BRANCH: BRADFORD DIVISION.

British Medical Association Lecture.

A MEETING of the Bradford Division was held at the Great Northern Victoria Hotel on May 4th. Dr. J. B. DUNLOP was in the chair and there were upwards of eighty present.

Dr. W. BLAIR BELL gave a most interesting and instructive lecture on "Some common, but often unrecognized, obstetrical difficulties." He spoke of unrecognized, un-complicated occipito-posterior presentations, post-maturity, and certain pelvic deformities which often escape detection, namely, the non-rachitic flat pelvis, the generally contracted pelvis, and the funnel-shaped pelvis. Lastly, the lecturer drew attention to primary uterine inertia, particularly to that form in which the normal pressor substances that stimulate uterine contractions are insufficient. The method of diagnosing and treating this condition was fully explained. The lecture will appear in a subsequent issue of the BRITISH MEDICAL JOURNAL.

Several pertinent questions were asked by members and Dr. BELL answered these very clearly. Dr. MANKNELL proposed a hearty vote of thanks to Dr. Blair Bell, which Dr. SHACKLETON seconded. Before the lecture Dr. Blair Bell was entertained to dinner by the Executive Committee of the Division.

METROPOLITAN COUNTIES BRANCH: CAMBERWELL DIVISION.

A MEETING of the Camberwell Division was held on May 13th, when the "National Provident Scheme for Hospital and Additional Medical Services" was discussed. A very clear description of the objects and scope of the scheme was given by Mr. W. McADAM ECCLES.

In the discussion which followed, the main objections raised were: (1) That the scheme was too ambitious and that the community would not subscribe the amount of money required, the insured persons being the only ones who would come automatically into the scheme. (2) That it was doubtful if there would be enough beds available, unless the Poor Law infirmaries were included in some way. (3) That the general practitioners would apparently be put to much extra trouble if consultations were numerous, and that suitable provision was not made in the scheme for remunerating them.

In his reply, Mr. ECCLES stated that of course, if the required number of subscribers were not obtained, the scheme would, at any rate, be a partial failure. With reference to objection (2) he quoted statistics to show that sufficient beds should be available in the voluntary hospitals, if properly distributed, and with regard to (3) he stated that there were suggestions being put forward with regard to remunerating general practitioners when present at consultations.

The following resolution was finally adopted unanimously:

That this meeting of the members of the Camberwell Division, having heard the lucid explanation given by Mr. McAdam Eccles of the new National Provident Scheme for Hospital and Additional Medical Services, agrees that a scheme on some such lines as this is very desirable as long as due consideration be given to the interests of the general practitioners and their patients.

METROPOLITAN COUNTIES BRANCH: MARYLEBONE DIVISION.

THE annual general meeting of the Marylebone Division was held at 11, Chandos Street, on May 10th, when Sir JAMES GALLOWAY was in the chair.

The annual reports of the Division and of the Executive Committee were read, discussed, and agreed to.

A prolonged discussion took place on the annual report of the Council regarding the question of federation and points were noted for instruction to the Representatives to Representative Meeting.

The following officers were elected for 1921-22:

Chairman: Dr. Blackhall-Morison. *Vice-Chairman:* Dr. F. W. Goodbody. *Honorary Treasurer:* Mr. Bishop Harman. *Honorary Secretaries:* Mr. C. E. Wallis and Dr. P. W. Spurgin. *Representatives in Representative Body:* Mr. McAdam Eccles, Dr. C. O. Hawthorne, Mr. Bishop Harman, Mr. C. E. Wallis, and Mr. H. S. Souttar. *Deputy Representatives:* Drs. Roxburgh, Jobson Horne, F. W. Goodbody, and E. E. Ware.

Representatives on the Branch Council were elected and nominations to the Branch Council and to the Central Council were agreed upon.

The report of the National Provident Scheme for Hospital and Allied Medical Services was discussed after a full explanation of the scheme by Mr. McADAM ECCLES.

A hearty vote of thanks to the retiring Chairman (Sir James Galloway) and to the officers of the Division was carried unanimously.

SURREY BRANCH.

A MEETING of the Surrey Branch Council was held at Wimbledon on May 11th, the President, Dr. A. E. EVANS, of Kingston Hill, being in the chair. It was unanimously decided to support the nomination of Dr. Arnold Lyndon, of Haslemere, for election to the Council, both on account of the many services he has rendered in the work of the Association, and especially in view

of his strong opposition to any non-medical body being admitted to the proposed Federation of the Association with the Irish and Overseas Branches. The Branch Council also recommended that the Surrey Divisional boundaries be investigated with a view to making various changes in order to improve the organization of the Association in Surrey.

The annual meeting of the Branch will be held this year in Guildford on Friday, July 8th.

WILTSHIRE BRANCH.

THE annual general meeting of the Wiltshire Branch was held at Trowbridge, on May 11th, when the President, Dr. HAYDON, was in the chair.

With reference to the resolution in regard to a county laboratory passed at the last meeting, the following small committee was appointed to confer with the county health authorities on any important matter which may from time to time arise: Drs. Flemming, Locket, Shorland, Adye, and Spence.

The following officers were elected for the ensuing year:—

President: Dr. C. E. S. Fleming. *President-elect:* Dr. J. E. Gordon. *Vice-Presidents:* Drs. Haydon and Kemp. *Honorary Secretary:* Dr. Bond. *Representative in Representative Body:* Dr. Flemming. *Deputy Representative in Representative Body:* Dr. J. E. Gordon.

Dr. Flemming was nominated by the Branch for election to the Council.

Dr. FLEMING announced that the University of Bristol would arrange a course of post-graduate lectures in Trowbridge towards the end of the summer, and asked for suggestions as to subjects and days. It was considered that Wednesday at 3.30 p.m. would be the most convenient time, and the subjects suggested were vaccine therapy and the treatment of fractures by the general practitioner.

Dr. FLEMING opened a discussion on the question of a voluntary hospitals association for the county, and a scheme for hospital finance, and asked all members interested to attend a meeting to consider the question at Trowbridge on May 21st. A general discussion followed, in the course of which Dr. LUCKHAM outlined the efforts which are now being made in Salisbury to increase the revenue of the Salisbury General Infirmary.

WORCESTERSHIRE AND HEREFORDSHIRE BRANCH.

THE spring meeting of the Worcestershire and Herefordshire Branch was held at Ledbury on April 7th, when the President, Dr. STEED, was in the chair. Mr. P. L. DANIEL (Surgeon to Charing Cross Hospital) read an interesting and instructive paper on "Differential diagnosis of acute abdominal conditions from a clinical standpoint"; this was followed by a discussion, in which Drs. STEED, BATES, HOLBECH, SMYTHE, and BUTLER took part. Mr. Daniel subsequently replied to questions. The meeting then adjourned for tea, after which Mr. T. BATES (Worcester) showed some interesting cases. A hearty vote of thanks was unanimously accorded to Mr. Daniel for his paper, and to Dr. Bates for his demonstration of cases.

ZANZIBAR BRANCH.

A MEETING of the Zanzibar Branch was held at the Health Office on March 8th. A demonstration was given by Dr. SPEARMAN and Dr. ADERS, Economic Biologist (Complimentary Member), on the following subjects:

1. Exhibition of bilharziasis arranged graphically to demonstrate Dr. Balfour's method of illustrating tropical diseases.
2. Working of the Zanzibar mosquito brigade. The use of mosquito larval traps on periphery of the town as indicators. Demonstration of working traps.
3. Demonstration of tuberculous kidney from town milk cow with involved mesenteric gland. Stone in kidney of horse.
4. Demonstration of Dr. Spearman's method of thick films for the rapid finding of malarial parasites: (a) Thin film (scanty infection); (b) thick film from same patient—numerous parasites.
5. Eggs of helminths preserved in 10 per cent. formalin.

The meeting was well attended and considerable interest was shown in the exhibits. At the conclusion of the proceedings a vote of thanks was accorded to the organizers of the meeting.

MEETINGS TO BE HELD.

BIRMINGHAM BRANCH: CENTRAL DIVISION.—The annual meeting of the Central Division will be held at 18, Bennett's Hill, on Thursday, June 16th, at 3.45 p.m. Agenda: To instruct Representatives. To elect officers for ensuing year. Nominations for officers must be in the hands of the Honorary Secretaries fourteen days before the meeting. Members are requested to bring with them copies of the SUPPLEMENT of April 30th.

KENT BRANCH.—The eighth annual meeting of the Branch will be held on June 9th, at 2.30 p.m., at the London County Council Mental Hospital, Bexley, near Dartford. Agenda: To receive (a) report of the election of officers for 1921-22; (b) annual report and financial statement. To elect an auditor. Any other business. The Council will meet before lunch, and due notice, with agenda, will be sent to members of Council. The President-elect, Lieut.-Colonel T. E. Knowles Stansfield, C.B.E., kindly invites members to lunch at 1 p.m., at the hospital. The business meeting will be followed by the presidential address, entitled "Our 'C3' population." A garden party will be given by Mrs. Stansfield afterwards. Arrangements will be made for the entertainment of the ladies during

the business meeting and the presidential address. Members intending to be present at the lunch and meeting are requested to send a postcard to Dr. C. H. Ockwell, White Hill House, Crayford, Kent, not later than Monday morning, May 30th.

METROPOLITAN COUNTIES BRANCH.—The annual general meeting of the Metropolitan Counties Branch will be held at 429, Strand, W.C., on Friday, June 24th, at 4 p.m. Business: (1) Report of scrutineers as to the election of new officers. (2) Annual Report of Council. (3) Alteration in Rule 11 by the insertion of words providing that such members of the Branch as are members of the Central Council shall be *ex officio* members of the Metropolitan Counties Branch Council. (4) President's address by Dr. H. B. Brackenbury, on The Psychologist in Public Life.

METROPOLITAN COUNTIES BRANCH: CITY DIVISION.—The annual general meeting of the City Division will be held at the Metropolitan Hospital on Friday, May 27th, at 9 p.m. Agenda: (1) Election of officers and Representatives for ensuing year. (2) Instructions to Representatives. (3) 10 p.m., Address by Dr. H. B. Brackenbury, Vice-President of Branch and President-elect of Branch. Dr. Brackenbury will explain the National Provident Scheme for hospital and additional medical services. As this is likely to affect the general practitioner very closely, it is hoped that everyone will make a special effort to be present. It is particularly to be desired that as many members as possible who are resident in the Islington section shall attend. It is proposed during the next session to hold several of the meetings, both clinical and ordinary, in the Islington area. During the session 1921-22 there will be a dinner entertainment (on November 3rd) and three dinner dances. Monthly lectures will be given; the first, in October, being a dental lecture, with lantern slides, by Dr. C. E. Wallis.

MIDLAND BRANCH: KESTIVEN DIVISION.—The annual meeting of the Division will be held at Dr. T. P. Greenwood's residence, 36, St. Mary's Street, Stamford, on Tuesday, May 31st, at 3.30 p.m. Business: (1) To elect the Chairman and Committee for the ensuing year. (2) To elect a Representative in Representative Body. For the purpose of this election, this meeting is a joint meeting of the Kesteven and Holland Divisions. (3) To discuss the agenda for the Annual Representative Meeting, and to instruct the Representative thereon. The honorary secretary, Dr. C. H. D. Robbs, informs members that he has obtained authority from the bodies concerned, throughout the Division, for the fees paid to medical practitioners called in by the police to be: day call, 7s. 6d.; night call, 10s. 6d. Tea will be provided at the conclusion of the meeting, and it is hoped that objects of interest in Stamford may be viewed.

WORCESTERSHIRE AND HEREFORDSHIRE BRANCH.—The annual meeting of the Worcestershire and Herefordshire Branch will be held at the Infirmary, Worcester, on June 30th, at 3 p.m.

Association Notices.

REPRESENTATIVE MEETING.

DATE.

THE Annual Representative Meeting at Newcastle will begin on Friday, July 15th, 1921, at 10 a.m.

NOTICES OF MOTION AND AMENDMENT BY DIVISIONS AND BRANCHES.

The Supplementary Report of Council to the Representative Meeting will appear in the SUPPLEMENT of July 2nd, 1921.

Notices of Motion and Amendment by Divisions and Branches for consideration by the Annual Representative Meeting will be published in the SUPPLEMENT as they are received, but none can be published later than July 2nd, for which purpose they must be received by the Medical Secretary not later than the first post on Monday, June 27th.

It will be possible, however, to include in the Agenda for the Annual Representative Meeting all Notices of Motion and Amendment which are received by the Medical Secretary *not later than the first post on Monday, July 11th, 1921.*

LIBRARY OF THE BRITISH MEDICAL ASSOCIATION.

A LIST of periodical publications, official reports, and Blue Books in the Library of the British Medical Association available for issue to members on loan has been printed, and copies can be obtained free on application to the Librarian at the house of the Association, 429, Strand, W.C. The regulations governing the loan of these publications are stated in the introduction to the list. The Library is open for consultation from 10 a.m. till 6.30 p.m. (on Saturdays 10 a.m. till 2 p.m.).

GENERAL COUNCIL

OF

MEDICAL EDUCATION AND REGISTRATION.

SUMMER SESSION, 1921.

Tuesday, May 24th, 1921.

Sir DONALD MACALISTER, K.C.B., President,
in the Chair.

THE one hundred and thirteenth session of the General Council of Medical Education and Registration was opened on May 24th.

PRESIDENT'S ADDRESS.

Sir DONALD MACALISTER said: I am happy to note that no change has taken place in the membership of the Council since we last met. All the retiring members have been reappointed, and we now welcome them back. Two former members, Sir Frederick Taylor, our late Treasurer, and Mr. R. J. Pye-Smith, of the University of Sheffield, have passed away. There is little doubt that the sorrows and labours of the years of war had a share in shortening their valuable lives.

His Majesty the King has conferred the dignity of knighthood on our colleague, Sir Edward Coey Bigger, the distinguished Chairman of Council of the Irish Ministry of Health. I offer him in your name the Council's congratulations and good wishes.

Medical Reciprocity.

Through the Privy Council we have been in correspondence with certain foreign countries and dominions of the Crown on the subject of medical reciprocity. Belgium, which, during the war, granted to British practitioners the privilege of practising within its territories, was by Order in Council accorded corresponding privileges under Part II of the Medical Act, 1886. Its medical graduates were accordingly made registrable in the British Foreign List, and some 104 were duly registered. The Belgian Government has now decided to reinstate its former medical regulations, which require our practitioners to obtain a Belgian qualification as a condition of practice. The conditions of reciprocity being therefore no longer maintained, His Majesty in Council has issued an Order revoking the application of Part II to Belgium, and Belgian practitioners will in future be registrable only in respect of British qualifications. Those already registered will, however, retain their status in this country.

In Spain the law has hitherto provided that individual foreign practitioners may, under certain conditions, obtain special permission to practise in that country. A change in the law is, however, in contemplation, and the British Ambassador has suggested that His Majesty's Government may see its way to granting reciprocity. The Executive Committee has requested that inquiries may be made as to the privileges which would be granted in Spain to practitioners registered in the United Kingdom, and as to the course of study and examinations prescribed for obtaining medical degrees and diplomas in Spain. We await the result with interest.

The Union of South Africa, which admits to its *Medical Register* practitioners registered in the United Kingdom, has within the last few years made much progress in developing its own system of medical education. Its universities have obtained power to confer degrees in medicine and surgery, and the Union is desirous that these degrees should, in due course, be recognized as registrable qualifications at home. The Executive Committee, to which the Council has delegated the supervision of such matters, has had no difficulty in advising the Lord President that Part II of the Medical Act may properly be applied to South Africa, and it is probable that before long the necessary Order in Council will be issued. The Council will then be free to recognize South African medical degrees which fulfil the prescribed conditions.

For many years the medical diplomas of the Indian universities have been recognized by the Council as conferring a registrable qualification to practise medicine, surgery, and midwifery in this country. Recent inquiries by the Executive Committee have, however, caused the Committee to raise the question of their present sufficiency in respect of midwifery. The information received from

India has satisfied the Committee that in most, if not all, of the Indian universities, the prescribed courses of study and examinations in this important branch do not now furnish (in the words of the Medical Act, 1886) "a sufficient guarantee of the possession of the requisite knowledge and skill for the efficient practice" of midwifery in the United Kingdom. The Committee has communicated its opinion to the Indian universities, and intimated that unless within a year the standard of their requirements in midwifery is raised to a satisfactory level, recognition must be discontinued. The Council is charged under the Act with ascertaining, not the sufficiency of Indian qualifications for the needs of practice in India, but their sufficiency as conferring a registrable title to practise all three branches of the profession in this and other non-Indian parts of the Empire.

Dangerous Drugs Act.

The Pharmacopœia Committee has had under consideration the Draft Regulations proposed by the Home Office for giving effect to the recent Dangerous Drugs Act. The Committee pointed out to the authorities various particulars, suggested by its members and by other members of the Council, in which amendment of the draft was necessary in the public interest. The chairman and secretary, on behalf of the Committee, have had interviews with the officials concerned, and have by request given information on the subject to a special committee set up by the Home Secretary for the purpose of considering the numerous amendments to the Draft Regulations that had been proposed by medical and pharmaceutical bodies. It is understood that a detailed revision of the original text has been undertaken by the Home Office, with a view to removing, so far as the Act permits, the objections urged against the draft. We have not yet received copies of the regulations as amended, but we understand that effect will be given to our representations.

Therapeutic Substances Insusceptible of Chemical Analysis.

The Departmental Committee appointed by the Ministry of Health to consider and advise upon the administrative measures to be taken for the control of the quality of certain therapeutic substances, such as serums, vaccines, salvarsan, etc., which cannot be tested by direct chemical means, has issued its report. The recommendations give effect, in what appears to be a satisfactory manner, to the wishes of the Council, as expressed in a communication made to the Lord President in 1909. They will be considered in detail by the Pharmacopœia Committee, and reported on by the Council at this session.

The Dentists Bill.

The Dental Committee also has been active during the recess in considering and advising on the successive drafts of the Dentists Bill during the course of its preparation by the Ministry of Health. As it was made abundantly clear that the bill would have little prospect of passing into law unless its provisions were generally agreed to beforehand by the various bodies concerned, a number of conferences have taken place at which the views of the Council and those of representative members of the dental profession were discussed with the officers of the Ministry. The bill is now before Parliament, and has been read a second time in the House of Commons. While it embodies many of the points on which the Council has from time to time laid stress, it contains one or two that have not yet been considered by the Dental Committee or endorsed by the Council. On these it is possible that the Council may have further instructions to give to its representatives. But the bill makes so great a step towards the removal of the dangerous abuses revealed by the Departmental Committee's Report that, though we may regret its imperfections, we may be prepared to welcome it as an earnest of wider reforms. I may mention that, at the instance of the Lord President, a clause has been introduced to give effect to your resolution of November 27th, 1917, whereby three additional members of the Council, who are registered graduates or licentiates in dental surgery, and members of the new Dental Board, are to co-operate with the Council when dealing with dental matters. The additional or dental members are to be appointed by the Privy Council.

Procedure for Election of Direct Representatives.

No progress has been made by Parliament with the bill for simplifying the procedure at the election of direct representatives to the Council. This is to be regretted, in view of the economies which a suitable change in the law would have made possible.

Finance.

The finances of the Council for the year 1920 show a satisfactory revival as compared with those of the war years. The aggregate surplus of income over expenditure in the General and Branch Councils amounts to £1,960. The considerable expenses incurred in carrying out the inspection and visitation of examinations have been met by a draft on the reserve fund. The number of registrations in the Home List of the *Medical Register* has risen to a little over 1,100, or almost exactly the same as the numbers for 1912 and 1913. To these must be added 343 registrations in the Colonial and Foreign Lists, as against 53 in 1912 and 65 in 1913. The increase of receipts from registration fees accounts indeed for the greater part of the accrued surplus.

Number of Medical and Dental Students.

The registrations of medical students, which in 1919 rose to 3,420, in 1920 fell to the more manageable number of 2,531; but this number is still higher than in any year prior to 1919. In my opinion, it would be in the interest of sound professional education were the numbers still further reduced. They impose a severer strain, educational and financial, on the schools and hospitals than the necessary recruitment of the profession demands, and in present circumstances the teaching institutions are less able to meet the strain. To raise the educational standard for admission, and to increase the fees for professional tuition, would thus seem, from all points of view, to be prudent and justifiable.

In respect of dentistry, a profession which still needs a large accession of fully trained recruits, the registrations in the *Dentists Register* number 217, as compared with 128 in the year before. They still fall short of the annual number before the war. New dental students, however, number 560. This, though somewhat less than in 1919, is (except for that year) the highest entry yet recorded. The small addition to the ranks of qualified dentists accounts, no doubt, for the unfavourable position of the dental fund. Last year it showed a deficit of £547. Should the Dentists Bill become law, a new position will be created, and comparison with the present statistics will no longer be practicable. It is for this reason that I have ventured to bring to your notice the figures relating to what may be the final stage of the *régime* which has lasted since 1878. The finances of the Dental Board will have other resources to draw upon and other charges to reckon with, under the new conditions.

The Medical Curriculum.

The procedure which you authorized in November for the investigation of the medical curriculum has been duly carried into operation under the direction of the Education Committee. In connexion with each Branch Council, four subcommittees have been set up, including many men of eminence in the sciences bearing on medicine and in its practice. These have readily lent their valuable aid to the Council's inquiry, and our thanks are due to them for their helpful co-operation. A number of preliminary reports and memoranda on different branches of the subject have been prepared and circulated to members. Before long joint meetings and conferences will be arranged for the co-ordination of these proposals, with a view to the elaboration of considered conclusions and recommendations for presentation to the Education Committee and ultimately to the Council.

Reports on Examinations.

The reports of the Inspectors and Visitors of qualifying examinations in the United Kingdom are now nearly complete. They have still to be considered as a whole by the Examination Committee, which will probably be able to report to you upon the entire cycle in November. But I may here be allowed, by anticipation, to offer my grateful acknowledgements to your Inspectors and Visitors for the conscientious and judicial spirit in which they have

fulfilled their important duties. The like acknowledgements are due to the Inspector of Public Health Examinations, Dr. Bruce Low, who has practically finished his task. The Public Health Committee may be able, at this session, to bring before you some results of the inspection, and to make a beginning with the revision of the rules governing the course of study and examinations for the diploma. The Council will probably think it desirable, as on previous occasions, that the new rules should be circulated in draft form to the qualifying bodies for their observations thereon, before they are finally submitted by the Committee for confirmation.

Disciplinary Cases.

The disciplinary cases to be inquired into at this session are few and simple. The Executive Committee proposes that we should take up the first one this afternoon, in order that we may, so far as is possible, economize our time, and be able sooner to deal with the other business on the programme. Under the uncertainty of present conditions, members will probably be desirous of making the session a short one. Let us hope that in November we may be able to meet, for the important business which will then be ready for our consideration, in greater comfort and in more assured peace.

Note of Thanks.

A vote of thanks to the President for his address was accorded by acclamation, on the motion of Sir NORMAN MOORE.

ELECTION OF COMMITTEES.

The following members of Committees were appointed:

Business Committee.—Dr. Norman Walker (chairman), Sir Francis Champneys, Dr. Macdonald, Dr. Magennis, the President (*ex officio*).

Pharmacopœia Committee. The President (chairman), Dr. Caton, Dr. Hopkins, Dr. Matthew Hay, Dr. Norman Walker, Dr. Kidd, Sir John Moore, Sir Norman Moore, Dr. Russell Wells.

Finance Committee.—Sir Norman Moore (chairman), Mr. Waring, Sir James Hodson, Sir Arthur Chance, the President (*ex officio*).

Dental Committee.—The President (chairman), Mr. Bennett, Sir James Hodson, Sir Arthur Chance, Mr. Waring.

Dental Education and Examination Committee. Sir James Hodson (chairman), Mr. Bennett, Mr. Waring, Dr. Adams, Sir E. Coey Biggar, Sir Arthur Chance, the President (*ex officio*).

Students' Registration Committee.—Sir Norman Moore (chairman), Sir Gilbert Barling, Mr. Littlejohn, Dr. Mackay, Dr. Kidd, Mr. Sinclair, the President (*ex officio*).

Executive Committee.—The President (*ex officio*), Sir Gilbert Barling, Dr. Macdonald, Sir Norman Moore, Mr. Waring, Sir James Hodson, Dr. Norman Walker, Sir Arthur Chance, Sir John Moore.

Penal Cases Committee.—The President (*ex officio*), Sir Francis Champneys, Sir Arthur Chance, Dr. Norman Walker, Dr. Macdonald.

FINANCE.

The report of the Finance Committee, on the motion of its Chairman, Sir NORMAN MOORE, seconded by Mr. WARING, was received and approved. The income of the General and Branch Councils for the year 1920 was £11,398 and the expenditure £9,438, leaving a surplus of £1,960 as compared with surpluses of £874 for the year 1919 and £341 for 1918. The assets of the General Council have fallen by £1,695; this is chiefly due to the transfer from the reserve of £1,772 to meet the cost of the inspection of examinations now taking place. The expenditure is not one which occurs annually, and therefore it has proved convenient to have a fund upon which to draw, thus obviating a large drain upon the resources of the Branches and rendering the comparison of accounts more easy. The receipts from the sale of the *Medical Register* and other publications of the Council amounted to £256 in 1920; this was almost double the amount received in each of the two preceding years. In this connexion the Finance Committee reports that lists of new registrations each month are now supplied on payment to various bodies and firms to which they are of use, and it is hoped to add to the number of subscribers; the payments received amount to a considerable sum, and the increasing use made of the *Register*, as the book of reference for all those who require to know if persons are "legally qualified" or not, should lead to further sales.

INSURANCE PRACTITIONERS AND TUBERCULOSIS REPORTS.

THE Ministry of Health has issued the following Memorandum (48 T.), dated May, 1921, on the procedure suggested for adoption by insurance officers in regard to reports on insured patients furnished by practitioners under the National Insurance (Medical Benefits) Amendment Regulations (No. 2), 1921. Copies of the memorandum have been forwarded by the Ministry to county and county borough councils, metropolitan borough councils, and Tuberculosis Joint Committees in England for circulation among clinical tuberculosis officers.

Memorandum by the Ministry of Health.

1. Under the above-mentioned Regulations, which operate from the 1st day of May, 1921, insurance practitioners are required, as formerly under the Tuberculosis (Domiciliary Treatment in England) Order, 1916, which is superseded by these Regulations, to furnish in a prescribed form periodical reports upon each of their insured patients who is suffering from tuberculosis. The Regulations, of which a copy is enclosed, provide for the reports to be transmitted by the practitioner to the Regional Medical Officer appointed by the Minister in accordance with the provisions of the National Health Insurance (Medical Benefits) Regulations, 1920, for the district in which the practitioner carries on insurance practice, and the Regional Medical Officer will forward the reports received to the appropriate Tuberculosis Officer.

2. The Regulations also provide that in regard to each insured patient suffering from tuberculosis the first report is to be made when treatment is first required to be given by reason of tuberculosis, and that subsequent reports must be made at such reasonable intervals, not exceeding three months, as may be arranged between the practitioner and the Regional Medical Officer during the continuance of the treatment. It will presumably only be in exceptional circumstances that a shorter interval than three months will be considered necessary, and the Regional Medical Officer will not in any case, either when acknowledging receipt of the initial report upon a particular case from the practitioner or in subsequent correspondence, specify a shorter interval except at the desire of the Tuberculosis Officer concerned.

3. In order to avoid unnecessary correspondence it is considered desirable that reports upon a particular case subsequent to the first should be sent direct by the practitioner to the Tuberculosis Officer of the Dispensary serving the district in which the patient resides, and the Regional Medical Officer will on receipt of the initial report inform the practitioner to this effect. Similarly any communications in regard to such later reports should as far as possible pass direct between the Tuberculosis Officer and the practitioner—see paragraphs 4, 5, and 6.

4. The initial report should ordinarily be sent by the practitioner to the Regional Medical Officer on his own initiative, but cases may arise in which a practitioner fails to furnish an initial report upon a tuberculous patient. It is suggested that the adoption of the following procedure by Tuberculosis Officers will ensure, *inter alia*, that initial reports are obtained through the Regional Medical Officer in all cases, and will be convenient in other respects:

(a) In new cases of tuberculosis which come to the Tuberculosis Officer's notice, through the notifications made under the Tuberculosis Regulations or otherwise, the Tuberculosis Officer should in the first instance communicate by telephone or otherwise with the practitioner who notified the case and inquire whether he desires to consult the Tuberculosis Officer in regard to the form of treatment most suitable to the circumstances of the case, and (unless the Tuberculosis Officer already possesses information on the point) whether or not the patient is an insured person. In the case of an insured patient, the Tuberculosis Officer should, after an interval of a week, if in the meantime no report is received from the practitioner in attendance, bring the matter to the notice of the Regional Medical Officer, who will in accordance with instructions issued to him take the steps necessary to secure the submission of the report required.

(b) In cases of tuberculosis in which the initial report has been received by the Tuberculosis Officer from the Regional Medical Officer, the Tuberculosis Officer should, after an interval ordinarily of three months from receipt of the report, intimate to the practitioner that a further report is due. It may be found convenient for the Tuberculosis Officer to obtain from the Insurance Committee concerned copies of the form prescribed for such reports and to remind the practitioner that a report is due by sending him a copy of the form with the name and address of the patient inserted.

If the report is not promptly received by the Tuberculosis Officer he should communicate with the Regional Medical Officer in order that appropriate action may be taken by the latter.

(c) As regards tuberculous insured persons already under treatment by insurance practitioners on the 1st May, 1921, the Tuberculosis Officer should, when the next report has become due, proceed as in 4, b).

5. In cases where reports made under the Regulations, and received by the Tuberculosis Officer from the Regional Medical Officer or from the practitioner direct, are defective, it will be convenient if requests for amendment of such reports are sent by the Tuberculosis Officer direct to the practitioner concerned in the first instance. If, however, difficulty is then experienced in obtaining an amended report the Tuberculosis Officer should communicate the facts to the Regional Medical Officer stating the amendments desired, in order that the latter officer may take steps to have the necessary amendments effected.

6. Under the Regulations, a practitioner, in addition to furnishing periodical reports, is required to confer with the Tuberculosis Officer, at such times and in such circumstances as may be arranged between them, in regard to patients suffering from tuberculosis. It should be noted that it rests with Tuberculosis Officers to arrange direct with practitioners for such conferences upon particular cases of insured tuberculous patients.

Correspondence.

Dr. Macdonald's Mission to South Africa.

SIR,—Under the heading "Dr. Macdonald's Mission to South Africa," in your issue of March 12th, 1921 (SUPPLEMENT, p. 70), there are certain inaccuracies which require correction.

It would appear that Dr. Macdonald gave an account of the proposal to establish a Medical Association of South Africa to a Council meeting held on February 26th. Dr. Macdonald attended the meeting of delegates of the British Medical Association at the Durban Congress when this question was discussed. He states, quite correctly, that one object of the proposed new association was to obtain national expression, but he is reported to have continued in the following terms:

"A keen discussion took place, during which it appeared that the movers in the scheme proposed to form the new association into a trade union and register it as such. It seemed that in this matter they considered they would be hampered by the constitution of the British Medical Association, and that they were of opinion that the British Medical Association could not undertake collective bargaining."

Now, Sir, Dr. Macdonald has apparently entirely misunderstood the position taken up by the Witwatersrand Branch of the British Medical Association and the arguments used by the movers of the resolution of that Branch.

The possibility of forming a trade union was never contemplated or considered in the deliberations of the joint committee of the two medical associations appointed to draw up the draft constitution of the South African Medical Association. The suggestion that such a trade union should be registered is absurd in the face of the fact that there is no such body as a trade union in the legal sense in this country, and no means therefore by which it could be registered.

Again, there is no doubt in our minds that the British Medical Association can and does engage in collective bargaining. The point is that in this country the British Medical Association cannot, under its constitution, enforce any such bargain upon its members. That is the legal opinion we have obtained.

Finally, let us be quite plain upon the issues involved:

1. We want an association of a national character which will attract all members of the profession irrespective of race or politics.
2. We want to have the power, amongst others, to bind our members to conform to the decisions of the association, but
3. We do not want a trade union.

— We are, etc.,

RONALD P. MACKENZIE,
FRANCIS NAPIER,

Mover and Seconder of the Resolution
at the Durban Congress.

Johannesburg, April 27th.

Anaesthetists' Fees in Insurance Practice.

SIR, The discussion that has recently taken place under this heading raises the important question of the payment of medical men for attendance on insured persons in hospital.

Is there any statement in the terms of service under the National Health Insurance Act that we are required to give only domiciliary and not institutional attendance?

The terms of service include:

Range of Treatment.—"The treatment which a practitioner is required to give to his patients comprises such treatment as is

of a kind which can, consistently with the best interests of the patient, be properly undertaken by a general practitioner of ordinary professional competence and skill."

Visiting.—"A practitioner is required to visit and treat a patient whose condition so requires at any place where the patient may at the time be within the district in which the practitioner has under these terms of service undertaken to visit patients."

So that, provided the attendance required is within the stated range, we may assume that the practitioner is required to give it whether the patient is in an institution or not, provided he is in the agreed district.

The competence of a general practitioner is not lessened by having to give attendance in an institution. We claim that the primary or cottage hospital is a general practitioner hospital, and that, given the advantages of an institution, we can there practise our profession more effectively and more easily than in the homes of our patients.

If it is worth our while to attend patients in their homes for the insurance fee that we get, surely it is a much better bargain for us for the same fee to attend those same patients in hospitals, where the time taken for visiting is less, where more than one patient can often be seen at the same visit, where a good deal of the work that we have to do ourselves in the home is done for us by the nurse, and where we can leave patients to be watched by trained attendants, that at home we might require to visit frequently for mere observation.

If institutional treatment is more effective patients are cured in a shorter time, and so require a less amount of attendance from the medical man.

In recent discussions as to paying wards in hospitals, Poor Law institutions, etc., the right of the general practitioner to follow his patient has always been advanced, as also has his demand to be allowed to take part in the work of the various communal clinics, so that we must be careful not to depreciate our competence to undertake such work, or we may find it difficult to sustain our claim.

It should be no more difficult to define general practitioner work in hospital than in domiciliary practice.

If the above stated views are accepted we shall give attendance in primary hospitals as part of our contract, and then the question arises as to the payment of the medical man who gives general practitioner attendance in hospital to a patient who is on the list of some other medical man in the district—should not that medical man be responsible for the payment? otherwise we may find practitioners sending patients into hospital and themselves receiving payment for work which others are doing. If such payment is to be made, the method (not the fees) adopted under the Insurance Act for payment for emergency treatment would seem convenient and fair.

Insured persons from other districts could be paid for as temporary residents.

Until we settle the question here raised we cannot deal satisfactorily with the rest of the problem of the payment of the medical staffs of voluntary hospitals.—I am, etc.,

CHAS. E. S. FLEMMING.

Bradford-on-Avon, May 22nd.

SIR,—The Croydon Panel Committee resolved that Clause 2, paragraph 1, of the Distribution Scheme should run as follows:

"In cases in which the co-operation of a second practitioner is required in the performance, under a general anaesthetic, of an operation within the scope of medical benefit, and where no provision would otherwise ordinarily be made for the administration of the anaesthetic, the following scale of fees," etc.

This wording, if adopted by other Committees, should quiet the fears of your previous correspondents.—I am, etc.,

G. GILBERT GENGE,

Croydon, May 21st.

Hon. Secretary.

Election of Panel Committees.

SIR,—The suggested schemes just issued by the Ministry of Health are but little improvement upon the originals.

The term of office of the Committee may be two years, or a number of the members are to be elected annually, the election in each case to be carried out by a special returning officer, who may not be an elector. *This involves unnecessary expense, trouble, and labour.*

The secretary of a Panel Committee is often a Panel practitioner, and hence may play no part in carrying out the election and can issue no notices, etc.

The election generally takes place at a general meeting at which topics of other interest are considered, and of which the honorary secretary gives notice, and the returning officer has to circularize all practitioners as well upon

the election—a double cost to be borne by the Panel Committee.

Surely a notice issued to practitioners by the secretary of the Panel Committee upon the election should suffice and be valid, and surely practitioners should be able to appoint their own representatives without having to pay for a returning officer, generally of the legal profession.

The Government negotiates with bodies elected under conditions far less stringent than those demanded by the Ministry of Health. Any method of election, provided it is carried out in good faith, should be allowed, and there is no necessity every year or two for the strict formalities of a parliamentary election. But the Ministry of Health loves red tape!—I am, etc.,

SIDNEY CLARKE, M.D.,

Honorary Secretary Hertfordshire (Local) Medical and Panel Committees.
St. Albans, May 15th.

National Health and the Practitioner.

SIR,—Apropos of your report of the discussion on "National health and the practitioner," in the SUPPLEMENT of May 14th, the question arises, How far are medical men generally content to leave advocacy in the hands of the "Reds"?

The discussion is opened by Dr. Buchan with claims and figures that would not deceive a schoolboy. But the humour of the situation emerges when, in quoting the enormous reduction in the death rate during the last forty years, he pushes for revolutionary changes in medical practice. If he does not get in quick enough with his whole-time public service and get every medico over thirty scrapped, there might be no death rate to worry about. He must hasten to draw blood from the retreating enemy ere he is beyond his reach.

Humour does not end with Dr. Buchan, however. Dr. Haslip, after criticizing Dr. Farquharson for a political platform speech, proceeds to deliver a typical harangue as addressed to an open air meeting of the un instructed. Communism out and out, of which the general practitioner is to bear the cost apparently. I do not know how far Dr. Haslip goes in his communism; most communists are discovered to have limits when cross-examined. Dr. Haslip talks airily about "the failure of the Insurance Act" as if it were an accepted fact. No statement could be further from the truth. Defects there are which are remediable, but on the whole it has worked well, and certainly no whole-time service that is conceivable would give better results.—I am, etc.,

Gateshead, May 15th.

JOHN L. SPEIRS.

SCHOLARSHIPS AND GRANTS IN AID OF SCIENTIFIC RESEARCH.

SCHOLARSHIPS.

THE Council of the British Medical Association is prepared to receive applications for Research Scholarships as follows:

1. An ERNEST HART MEMORIAL SCHOLARSHIP, of the value of £200 per annum, for the study of some subject in the department of State Medicine.
2. THREE RESEARCH SCHOLARSHIPS, each of the value of £150 per annum, for research into some subject relating to the Causation, Prevention, or Treatment of Disease.

Each scholarship is tenable for one year, commencing on October 1st, 1921. A Scholar may be reappointed for not more than two additional terms.

The Conditions of the award of Scholarships are stated in the Regulations, a copy of which will be supplied on application to the Medical Secretary of the Association, 429, Strand, London, W.C.2.

GRANTS.

The Council of the British Medical Association is also prepared to receive applications for Grants for the assistance of Research into the Causation, Treatment, or Prevention of Disease. Preference will be given, other things being equal, to members of the medical profession, and to applicants who propose as subjects of investigation problems directly related to practical medicine.

The Conditions of the award of Grants are stated in the Regulations, a copy of which will be supplied on application to the Medical Secretary of the Association, 429, Strand, London, W.C.2.

Applications.

Applications for Scholarships and Grants for the year 1921-22 must be made not later than Saturday, June 25th, 1921, in the prescribed form, a copy of which will be supplied by the Medical Secretary on application.

Each application should be accompanied by testimonials, including a recommendation from the head of the laboratory, if any, in which the applicant proposes to work, setting out the fitness of the candidate to conduct such work, and the probable value of the work to be undertaken. This is not intended, however, to prevent applications for Grants in aid of work which need not be performed in a recognized laboratory.

INSURANCE.

LOCAL MEDICAL AND PANEL COMMITTEES. COVENTRY.

THE Coventry Panel and Local Medical Committee met at Coventry on May 13th, Dr. W. H. Lowman presiding. The question of the amendment of the schemes governing the constitution of Panel Committees came under review, together with the suggestions of the Ministry as to amending the present schemes. It was decided to convene a general meeting of the Coventry electorate to place before them an amended scheme on which to hold the election, and not to proceed to the election on the current scheme. The variations from the present arrangements which are to be recommended to the electorate include the provision that one-third of the Committee shall retire annually, and that voting shall be by postal vote upon a circulated list comprising every doctor in the area, the matter of nomination to be dispensed with.

The nursing scheme recently circulated by the industrial group of approved societies, which is understood to have been recommended by the Queen Victoria Jubilee Institute to its affiliated branches, was reviewed and severely criticized. Members took strong exception to the possibility of the services of nurses being called to a case by any third party in the form of an approved society representative; and the following resolution was unanimously adopted, and authorized to be sent to the Insurance Acts Committee of the British Medical Association and others:

That, in the opinion of this Committee, any nursing scheme which imposes a charge upon the funds of insured members of approved societies, or which renders insured persons liable to a charge, should be the subject of arrangements made to the satisfaction of the Minister of Health acting in conjunction with Panel and Insurance Committees; and that this Committee strongly protest against any scheme in which the matter of requisitioning the services of a nurse is not left to the judgement of the medical practitioner.

Naval and Military Appointments.

ROYAL NAVAL MEDICAL SERVICE.

THE following notifications are announced by the Admiralty:— Surgeon Commanders: W. N. L. Chery to the *Banbow*, on recon-missioning; R. W. G. Stewart to the *Empress of India*, on recon-missioning; A. Woolcombe, to the *Glorious*, on becoming flagship. Surgeon Lieutenant Commander: H. E. Scargill to the *Triton*, additional, for special service. Surgeon Lieutenant A. C. Esmonde to Haslar Hospital.

Surgeon Lieutenant Commanders promoted to the rank of Surgeon Commander: H. F. Briggs, A. G. Malcolm, H. C. Devas, H. Burns, O. B. E.

Surgeon Lieutenants promoted to the rank of Surgeon Lieutenant Commanders: G. W. Woodhouse, H. B. Padwick, D.S.O.

ARMY MEDICAL SERVICE.

Lieut.-Colonel R. J. W. Mawhinny, C.B., from R.A.M.C., to be Colonel, December 25th, 1918, with pay and allowances from March 24th, 1921.

ROYAL ARMY MEDICAL CORPS.

Captain (temporary Major) A. S. Cane, D.S.O., O.B.E., retains his temporary rank whilst employed as D.A.D. of P.

Temporary Captain (acting Major) H. G. Hobson, O.B.E., M.C., to be Captain, with seniority December 19th, 1918, and to retain his acting rank.

The following temporary Captains relinquish their commissions: (Acting Major) C. C. Chance, M.C., and is granted the rank of Major; H. Stanger, and retains the rank of Captain.

Lieutenant temporary Captain T. B. H. Tabuteau to be Captain.

DEFENCE FORCE.

ARMY MEDICAL SERVICE.

To be Assistant Directors of Medical Services: Temporary Colonels F. W. Higgs, C.B.E., J. G. Martin, T.D., D. Rono, D.S.O., H. F. Samuel, D.S.O., E. A. Wraith, C.B.E., D.S.O. To be Deputy Assistant Directors of Medical Services: Temporary Captain S. S. Greaves, D.S.O., M.C., temporary Captain O. Teichman, D.S.O., M.C., temporary Major F. W. Squire, T.D.

R.A.M.C. To be temporary Majors: C. V. Balstrode, D.S.O., T.D., To be temporary Captains: J. D. G. Stewart, H. Drummond, W. J. C. Watt. To be temporary Lieutenant: G. L. Lyon Smith.

1st (East Anglian) Field Ambulance (D.F.)—To be temporary Major: W. S. Forbes, April 10th, 1921 substituted or London Gazette notification, April 27th, 1921, appointing this officer as temporary Captain. To be temporary Captains: A. G. Atkinson, M.B.E., H. F. Gilmore.

2nd (East Anglian) Field Ambulance (D.F.). To be temporary Captain: W. T. G. Boul.

1st (East Lancashire) Field Ambulance (D.F.).—To be temporary Lieut.-Colonel: T. B. Wolstenholme, O.B.E. To be temporary Captains: J. F. O. Grady, T. Hamilton.

1st (Highland) Field Ambulance (D.F.).—To be temporary Lieut.-Colonel: A. S. K. Anderson. To be temporary Lieutenants: I. S. Thompson, J. I. Moir, G. Burnett, D. R. Macdonald.

2nd (Highland) Field Ambulance (D.F.).—To be temporary Lieut.-Colonel: J. W. Tocher. To be temporary Major: W. F. T. Haultain. To be temporary Captain: H. J. Rae. To be temporary Lieutenant: H. J. Dawson.

3rd (Highland) Field Ambulance (D.F.).—To be temporary Lieut.-Colonel: G. W. Miller, D.S.O., T.D. To be temporary Major: W. A. Robertson, M.C. To be temporary Captains: J. Kinnear, D. Roger, W. E. A. Buchanan.

1st (Home Counties) Field Ambulance (D.F.).—To be temporary Captain: E. A. Houchin.

2nd (Home Counties) Field Ambulance (D.F.).—To be temporary Captain: R. A. Freeman.

3rd (Home Counties) Field Ambulance (D.F.).—To be temporary Captain: V. E. Negus.

1st (London) Field Ambulance (D.F.).—O. W. McSheehy, D.S.O., O.B.E. (Major R.A.M.C.) is granted the rank of temporary Lieut.-Colonel while commanding a field ambulance. To be temporary Major: E. Knight. To be temporary Captains: A. B. Mount, A. L. Robinson, R. J. Arundel.

1st London Sanitary Section (D.F.).—To be temporary Captain: H. C. Sands.

2nd London Divisional Sanitary Section (D.F.).—To be temporary Captain: H. Brian-Pearson.

2nd London Field Ambulance (D.F.).—To be temporary Lieut.-Colonel: H. G. Haynes. To be temporary Captains: M. Coughlan, W. Hassard. To be temporary Lieutenant: G. W. Almyede.

3rd (London) Field Ambulance (D.F.).—To be temporary Lieut.-Colonel: M. H. Allen. To be temporary Captain: L. J. G. Carre.

4th London Field Ambulance (D.F.).—To be temporary Captain: C. H. Welch.

5th London Field Ambulance (D.F.).—To be temporary Lieutenants: J. R. K. Flemming, H. W. Collins.

6th (London) Field Ambulance (D.F.).—To be temporary Captain: F. H. Bingley.

1st (Lowland) Field Ambulance (D.F.).—To be temporary Lieut.-Colonel: E. S. Forde. To be temporary Major: E. P. Cathcart. To be temporary Captain: J. K. Rennie. To be temporary Lieutenants: A. H. Jacobs, N. M. D. Fox.

2nd (Lowland) Field Ambulance (D.F.).—To be temporary Lieut.-Colonel: G. R. Fleming, M.B.E. To be temporary Major: J. R. C. Greenlees.

3rd (Lowland) Field Ambulance (D.F.).—To be temporary Lieut.-Colonel: F. A. E. Crew. To be temporary Captains: J. A. L. Loudon, C. G. Lambie. To be temporary Lieutenants: O. H. Wild, E. H. Ponder, K. K. S. Lun.

5th (Lowland) Divisional Sanitary Section (D.F.).—To be temporary Captain: M. Wilson.

2nd (Northumbrian) Field Ambulance (D.F.).—To be temporary Lieut.-Colonel: D. L. Fisher, D.S.O. To be temporary Major: V. Wardle, M.C. To be temporary Captains: D. Roberts, F. C. Pridham, W. McK. Wilson.

1st (South Midland) Field Ambulance (D.F.).—To be temporary Major: F. G. Hobson. To be temporary Captain: W. D. Garduer.

2nd (South Midland) Field Ambulance (D.F.).—To be temporary Major: Temporary Captain W. W. Newton. To be temporary Captain: Temporary Lieutenant N. C. Cooper.

3rd (South Midland) Field Ambulance (D.F.).—To be temporary Lieut.-Colonel: T. A. Green, D.S.O. To be temporary Major: D. S. A. O'Keefe. To be temporary Captains: A. D. Symons, J. C. Brasher. To be temporary Lieutenant: B. A. Astley-Weston.

3rd (Welsh) Field Ambulance (D.F.).—To be temporary Lieut.-Colonel: C. L. Isaac.

1st (Wessex) Field Ambulance (D.F.).—To be temporary Lieut.-Colonel: A. Cary. To be temporary Major: R. Ward.

4th (West Riding) Divisional Sanitary Section (D.F.).—To be temporary Captain: H. L. Robinson.

DIARY OF SOCIETIES AND LECTURES.

LONDON HOSPITAL MEDICAL COLLEGE.—Fri., 4 p.m., Schorstein Memorial Lecture by Dr. A. G. Gibson: Chronic Inflammatory Diseases of the Spleen.

ROYAL SOCIETY OF MEDICINE.—Section of Surgery: Wed., 5.30 p.m., Mr. C. A. Lannett: Treatment of Imperfectly Descended Testicle; Dr. A. Goodman Levy: Cardiac Massage. Section of Laryngology: Thurs., 2.30-6 p.m., Papers; Fri., 10 a.m. to 1 p.m., Papers; 2.30 to 4 p.m., Demonstrations; 4 p.m., Clinical Meeting; 7.30 p.m., Dinner; Sat., Visits to Hospitals.

ROYAL SOCIETY OF TROPICAL MEDICINE AND HYGIENE. 11, Chandos Street, W.1.—Fri., 5 p.m., Adjourned Meeting. Papers:—Lieut.-Colonel H. Kirkpatrick, I.M.S.(ret.): Some Points on Trachoma. Carlos Franca: An Early Portuguese Contribution to Tropical Medicine.

POST-GRADUATE COURSES AND LECTURES.

HOSPITAL FOR SICK CHILDREN, Great Ormond Street, W.C.—Thurs., 4 p.m., Dr. Still: Some Urinary Disorders.

INSTITUTE OF PATHOLOGY AND RESEARCH, St. Mary's Hospital, Paddington, W.—Thurs., 4.30 p.m., Professor G. Dreyer, F.R.S.: New Departure in the Serum Diagnosis of Syphilis.

LONDON HOSPITAL MEDICAL COLLEGE.—Mon., 5 p.m., Dr. W. M. Feldman: Ante-natal and Post-natal Child Physiology. Tues. and Fri., 5.15 p.m., Dr. M. Culpin: Psycho-neuroses.

MANCHESTER ROYAL INFIRMARY.—Thurs., 4.30 p.m., Sir William Milligan: Endoscopic Examination of the Food and Air Passages.

NATIONAL HOSPITAL FOR THE PARALYSED AND EPILEPTIC, Queen Square, W.C.—Mon., Tues., Thurs., and Fri., 2 p.m.: Out-patient Clinics. Lectures: 3.30 p.m., Mon., Dr. A. Turner: Psycho-neuroses; Tues., Dr. R. Russell: Myelitis; Wed., Mr. L. Paton: Optic Atrophy; Thurs., Dr. K. Wilson: Tumours of the Spinal Cord; Fri., Mr. Sargent: Surgical Treatment of Cerebral Compression.

QUEEN'S HOSPITAL FOR CHILDREN, Hackney Road.—Mon., 2.30 p.m., Mr. N. C. Lake: Juxta-Epiphyseal Strain and its Sequelae; Tues., 4.30 p.m., Dr. E. Pritchard: Dietetic Treatment of Wasting Babies; Thurs., 4 p.m., Dr. Parkinson: Demonstration of Heart and Lung Cases; Fri., 2.30 p.m., Mr. J. Taylor: Surgical Tuberculosis other than that of Bones and Joints.

WEST LONDON POST-GRADUATE COLLEGE, Hammersmith, W.—Daily, 10 a.m., Ward Visits; 2 p.m., In- and Out-patient Clinics and Operations; Tues., 12 noon, Mr. T. Gray: Demonstration of Fractures; Wed., 12 noon, Mr. Sinclair: Surgical Diseases of the Abdomen; Sat., 9 a.m., Dr. Barnford: Bacterial Therapy. Lectures: 5 p.m., Mon., Dr. A. Saunders: Gastic Disorders in Children; Tues., Mr. B. Davis: Clinical Lecture (Ear, Nose and Throat); Thurs., Fr., W. H. Wilcox: Toxic Conditions of the Liver; Fri., Mr. MacDonald: Retention of Urine.

British Medical Association.

OFFICES AND LIBRARY, 49, STRAND, LONDON, W.C.2.

Reference and Lending Library.

THE READING ROOM, in which books of reference, periodicals, and standard works can be consulted, is open to members from 10 a.m. to 6.30 p.m., Saturdays 10 to 2.

LENDING LIBRARY: Members are entitled to borrow books, including current medical works; they will be forwarded, if desired, on application to the Librarian, accompanied by 1s. for each volume for postage and packing.

Departments.

SUBSCRIPTIONS AND ADVERTISEMENTS (Financial Secretary and Business Manager, Telegrams: Articulate, Westrand, London), **MEDICAL SECRETARY** (Telegrams: Medisera, Westrand, London), **EDITOR, British Medical Journal** (Telegrams: Aitiology, Westrand, London).
Telephone number for all Departments: GERRARD 2630 (3 lines).

SCOTTISH MEDICAL SECRETARY: 6, Rutland Square, Edinburgh. (Telegrams: Associate, Edinburgh. Tel.: 4361 Central.)
IRISH MEDICAL SECRETARY: 16, South Frederick Street, Dublin. (Telegrams: Bacillus, Dublin. Tel.: 4737 Dublin.)

Diary of the Association.

MAY.

- 27 Fri. City Division, Annual Meeting, Metropolitan Hospital, 9 p.m. Address by Dr. H. B. Brackeough, 10 p.m.
Sheffield Division Annual Meeting, Church House, St. James Street, Sheffield, 8.30 p.m.
- 31 Tues. Kesteven Division Annual Meeting, 36, St. Mary's Street, Stamford, 3.30 p.m.
London: Grants Subcommittee, 12 noon.
London: Organization Committee, 2 p.m.

JUNE.

- 1 Wed. London: Medico-Political Committee, 2.30 p.m.
London: Journal Committee, 2.45 p.m.
- 3 Fri. London: Medico-Sociological Committee, 2.30 p.m.
- 7 Tues. London: Naval and Military Committee, 2.30 p.m.
- 8 Wed. North Lincolnshire Division, Grimsby: Address by Medical Secretary.
- 9 Thurs. Kent Branch: Annual Meeting, London County Council Mental Hospital, Bexley, near Dartford, 2.30 p.m.
- 10 Fri. London: Medico-Sociological Committee, 2 p.m.
- 14 Tues. Isle of Ely Division: Address by the Medical Secretary.
- 16 Thurs. Central Division, Annual Meeting, 18, Bennett's Hill, 3.45 p.m.
- 22 Wed. London: **Council.**
- 24 Fri. Metropolitan Counties Branch Annual Meeting, 429, Strand, W.C.2, 4 p.m.
- 30 Thurs. Worcestershire and Herefordshire Branch: Annual Meeting, The Infirmary, Worcester, 3 p.m.

APPOINTMENTS.

DICKSON, Kenneth, B.A., M.B., B.Ch.Cantab., M.R.C.S., L.R.C.P., Clinical Assistant to the Hospital for Sick Children, Great Ormond Street.

FISHER, A. G. Timbrell, M.C., F.R.C.S., Surgeon with charge of Out-patients at the Dreadnought Hospital, Greenwich, vice E. T. C. Milligan, O.B.E., F.R.C.S., promoted to the senior staff.

YOUNG, W. Arthur, B.Sc., M.B., B.S., Pathologist to St. John's Hospital for Diseases of the Skin, Leicester Square, W.C.

JESSOP HOSPITAL FOR WOMEN, Sheffield.—Honorary Surgeon: W. W. King, F.R.C.S. Edin., vice Percival E. Barber, Ch.M., resigned. Registrar: J. E. Stacey, F.R.C.S. Edin.

PADDINGTON GREEN CHILDREN'S HOSPITAL, W.—House-Physician: J. Cameron Morris, M.B., Ch.B. Edin. House-Surgeon: W. D. Brunton, M.B., Ch.B. Edin.

BIRTHS, MARRIAGES, AND DEATHS.

The charge for inserting announcements of Births, Marriages, and Deaths is 9s., which sum should be forwarded with the notice not later than the first post on Tuesday morning, in order to ensure insertion in the current issue.

BIRTHS.

DONALD.—On April 23rd, at Nursing Home, Mansfield, to Dr. and Mrs. S. J. W. Donald, Herne House, Sutton-in-Ashfield, Nottingham—a son.

FETHERSTON-DILKE.—On March 31st, at Leamington Spa, the wife of Beaumont A. Fetherston-Dilke, M.B.E., M.B. Cantab., M.R.C.P., of the West African Medical Staff, Nigeria, of a son.

DEATHS.

BARRETT.—On May 22nd, at Colwyn Bay, Walter Ernest, the beloved husband of Dorothy L. Barrett, after a long and painful illness.

JEFFERIES.—On May 21st, at 104, Chorley New Road, Bolton, Horace Jefferies, M.R.C.S., L.S.A., in his 61st year.

WEST.—On May 19th, 1921, at 43, St. George's Road, S.E.1, William Goldsbrough West, M.D., M.R.C.S., L.R.C.P. (second son of the Rev. George West, of Horham Hall, Thaxted, Essex), aged 55 years. R.I.P. (French papers please copy.)

The British Medical Association.

The publication of full details of the arrangements for the approaching Annual Meeting at Newcastle-upon-Tyne affords an opportunity to draw the attention of members of the Medical Profession to the principal aims and objects of the Association and to some general points in regard to its work and organization.

AIMS AND OBJECTS.

THE BRITISH MEDICAL ASSOCIATION, founded in 1832, was established to promote the medical and allied sciences and to maintain the honour and interests of the medical profession. It holds periodical meetings for the discussion of medical and scientific subjects; it publishes the *British Medical Journal*; it maintains a Reference and Lending Library, and it has instituted scholarships and makes grants for the promotion of the medical and allied sciences by research.

CONSTITUTION AND ADMINISTRATION.

Its constitution is founded on territorial Divisions formed of the members resident in the area. The Divisions number 279. For certain purposes Divisions are combined into Branches. The members of a Division elect a member or members of the Representative Body, which is the governing body of the Association and determines its policy. Persons of either sex are eligible for election on precisely the same terms.

The Council is the executive of the Association; it is elected partly by the Divisions and Branches, partly by the Representative Body, and includes also representatives of the Navy, Army, Air Force, and Indian Medical Services, elected by the Representative Body.

The Council and Representative Body are assisted by Standing Committees, among which may be mentioned the Science, Medico-Political, Ethical, Hospitals, Insurance Acts, Public Health, and Naval and Military Committees. There are Committees also for the Dominions, Scotland, Ireland, and Wales. There are Federal Committees for Australia and South Africa.

PRIVILEGES OF MEMBERSHIP.

A member of the British Medical Association has the right—

- To attend the annual and other general meetings of the Association and the meetings of the Division and Branch to which he belongs.
- To take part by personal vote, or in the case of some Divisions by voting paper, in the election of the representative of his Division to the Representative Body.
- To receive the *British Medical Journal*, which is published weekly, and is the most comprehensive medical periodical published in the British Empire, giving a complete conspectus of progress in clinical, scientific, and medico-political affairs.
- To receive the help and advice of central officials in any professional difficulty.

MODE OF ELECTION AND SUBSCRIPTION.

The subscription to the British Medical Association is 3 guineas a year for members resident in the United Kingdom. A member who joins within two years of the date of his registration as a medical practitioner pays 1½ guineas a year until he has been registered four years. Members joining after June 30th pay half the subscription for that year.

All duly qualified British medical practitioners are eligible for election as members of the British Medical Association. Full particulars can be obtained on application to the Medical Secretary, British Medical Association Building, 429, Strand, London, W.C.2. An application form will be found on page 219 of this issue of the SUPPLEMENT.

BRITISH MEDICAL JOURNAL.

LONDON: SATURDAY, JUNE 4TH, 1921.

CONTENTS.

	PAGE	PAGE
THE BRITISH MEDICAL ASSOCIATION: Its Aims and Objects	205	
Form of Application for Membership	219	
CURRENT NOTES:		
CENTRAL COUNCIL ELECTIONS	206	
VALUE OF THE ASSOCIATION TO INDIVIDUAL MEMBERS	206	
THE LOGICAL CONCLUSION	206	
THE NEED FOR A CENTRAL ORGANIZATION	206	
NURSING SCHEMES FOR INSURED PERSONS	207	
TREATMENT OF INSURED PERSONS IN HOSPITAL	207	
CHEMISTS' HOURS	207	
MEDICO-SOCIOLOGICAL SECTION AT NEWCASTLE	207	
MEETINGS OF BRANCHES AND DIVISIONS	207	
MEETINGS TO BE HELD... ..	208	
ASSOCIATION NOTICES:		
REPRESENTATIVE MEETING	208	
SCOTTISH COMMITTEE: ELECTION OF DIRECT REPRESENTATIVES	208	
ANNUAL MEETING AT NEWCASTLE:		
Programme	215	
Form for Notification of Attendance	217	
COLONIAL MEDICAL SERVICES: Letter to the Colonial Office	208	
DANGEROUS DRUGS REGULATIONS	210	
GENERAL MEDICAL COUNCIL:		
DANGEROUS DRUGS REGULATIONS	211	
PENAL CASES	212	
INSURANCE: KENT LOCAL MEDICAL AND PANEL COMMITTEE	213	
NAVAL AND MILITARY APPOINTMENTS... ..	213	
DIARY OF SOCIETIES AND LECTURES	214	
ASSOCIATION INTELLIGENCE AND DIARY	214	
APPOINTMENTS... ..	214	
BIRTHS, MARRIAGES, AND DEATHS	214	

British Medical Association.

CURRENT NOTES.

Central Council Elections.

MEMBERS of the following Branches of the Association who have not already done so, are requested to fill up and return to the Medical Secretary, 429, Strand, W.C.2, by first post on Monday, June 6th, the voting papers recently issued to them: Birmingham, Staffordshire, Metropolitan Counties, Bath and Bristol, Gloucestershire, West Somerset, Worcestershire and Herefordshire, Kent, Surrey, and Sussex.

Value of the Association to Individual Members.

Possibly one of the most frequent accusations made against the British Medical Association by hostile critics is that it does nothing for its individual members. Such a statement assumes that every member expects the Association to do something more for him in particular than supply him with an excellent weekly journal, provide him with a splendid library, all the advantages of an efficient organization, both scientific and medico-political, and many other things. If such an individual wishes to have proof that the Association can really do something which benefits him personally and particularly, two things are needful: (1) He must have a grievance or be in need of advice, and (2) the Association must be given the opportunity to help him. Experience in the office shows that only a very small percentage of members know how useful the Association can be if its help is requested. The following recent instances of assistance given to individuals may perhaps serve to enlighten the critics:

A. was starting in practice and had no idea what fees to charge. He wrote for information and was given some details of usual charges which, judging from his letter of thanks, were of great value to him.

B. called at the office to know in what circumstances she was entitled to an expert fee for giving evidence in the criminal court. The information given enabled her to obtain an expert's fee where she had previously obtained only an ordinary fee.

C. wrote to say that his local authority could not by any ordinary means be induced to pay him his fees for notification of infectious diseases. The case was taken up by the Association with the Ministry of Health, and the result is that C. will not have any more difficulty in the matter.

D. was in doubt as to what fee to charge when called in by a solicitor to give evidence in a case of criminal assault. The information given was cordially appreciated.

E. called at the office one day to explain that the Commissioners of Inland Revenue had refused him the relief of income tax to which he was entitled on his pay as a civilian medical practitioner at a hospital during the war. The Association

was in possession of a ruling by the Income Tax Commissioners to show that he was entitled to the relief, and as a result the case was very quickly settled in his favour.

Such cases are not unusual, but it is felt that they would be much more frequent if members appreciated that when in doubt or difficulty they should write to, or call on, the Medical Department, which will help whenever possible, and this, experience proves, is quite often.

The Logical Conclusion.

Not long ago the British Medical Association concluded a bargain with the Life Offices Association, representing most of the Life Insurance Companies in this country. The result was not all that was desired by either party—bargains seldom are—but, taking it as a whole, it is estimated to give the profession nearly a 50 per cent. increase per annum on the total amount formerly received for medical examination for life insurance. One of the companies concerned has treated the matter in a severely logical fashion. Finding that one of their examiners was not a member of the British Medical Association they sent him the old fee, and on his expostulating informed him that as he was not a member of the Association they did not think he was entitled to the increase. The company has been informed that in making the bargain the Association was acting for the whole medical profession, and that it cannot agree to any discrimination between different members of the profession. But perhaps there is something to be said for the attitude of the Life Insurance Company, and for relieving non-members of the Association from the invidious obligation of accepting benefits for which they have not subscribed.

The Need for a Central Organization.

The Inverness County Education Authority is endeavouring to make an arrangement whereby local practitioners can carry out the medical inspection of school children. The following extract from the circular letter which has been sent to the medical men concerned shows that the Education Authority recognizes the value of a central professional organization for the purpose of carrying out negotiations:

"The Authority would have preferred to have approached you through some central body, such as the local Branch or Division of the B.M.A. It was found, however, that, of the 20 medical men whose services are to be asked for only 8 are members of the B.M.A. It was resolved, therefore, to approach each parish council medical officer individually."

This should be an object lesson to the medical men concerned, for it is obvious that a strong central body would be able to obtain more favourable terms than are likely to be got by the individual. But it is a pity that such a truism should need to be pointed out by a third party.

Local authorities pay a good deal of attention in these days to organized opinion, and it is to be hoped that the lesson which the Inverness Education Authority has tried to inculcate will not be lost on the local profession.

Nursing Schemes for Insured Persons.

Numerous schemes for providing nursing services for insured persons are being promulgated in various parts of the country. Thus, a scheme is being put forward by the Industrial Approved Society Group and has been approved by the Queen Victoria Jubilee Institute for Nurses. In the original scheme no regulation was made which would compel the nurse to act under the direction of the attending medical practitioner, and a communication was addressed by the British Medical Association to the Queen Victoria Jubilee Institute expressing the hope that it would be made clear in the agreement that the nurse must act under the direction of the practitioner attending the case. Representations were also made to the Ministry of Health urging that its approval should not be given unless a clause safeguarding this important principle was inserted. A reply has been received from the Institute to the effect that it has been carefully explained to the representatives of the group of approved societies that the nursing will be carried on under the ordinary rules for district nursing (which are those approved by the British Medical Association and the Institute in conference some time ago). The Insurance Acts Committee, at its meeting on May 26th, expressed the opinion that any scheme for a nursing service for insured persons should form part of medical benefit and should be administered accordingly—that is, by Insurance Committees.

Treatment of Insured Persons in Hospital.

In connexion with the payment of insurance practitioners out of the Medical Benefit Fund for the administration of anaesthetics, the Insurance Acts Committee of the British Medical Association and the Ministry of Health agreed that in general it might be held that such payment was payable when the operation for which the anaesthetic was necessary was performed in a cottage hospital, provided (a) that the operation came within the scope of an insurance practitioner's agreement, and (b) that the hospital was one wherein any general practitioner could treat his own patients. This has raised the question of whether or not an insurance practitioner's agreement only covered what was understood as domiciliary attendance, or included attendance upon an insured person in an institution where the treatment was clearly within the "range of service." The Insurance Acts Committee is of opinion that the mere removal of an insured person to an institution does not necessarily take the patient outside the insurance practitioner's contract, and has referred to its Executive Subcommittee the question of ascertaining the limitations, if any, which should be placed upon such general rule in particular instances.

Chemists' Hours.

In at least one metropolitan area difficulties have constantly arisen because insured persons have had trouble in securing that their prescriptions are dispensed on the same night as that on which they are given by the practitioner. The reason for this is that the surgery hours of some practitioners are later than the hours of the local chemists, who are of course governed by the early closing legislation. These difficulties are likely to be obviated in West Ham, where by agreement between the Panel, Pharmaceutical, and Insurance Committees, insurance practitioners are being asked to close their surgeries at 8 p.m., while chemists remain open until 8.30 p.m.

Medico-Sociological Section at Newcastle.

This Section proposes to discuss the following question at its meeting on Friday, July 22nd:

The relation of the medical profession to local authorities in respect to rate-provided hospitals and clinics.

Efforts are being made to secure that certain well-known lay authorities shall take part in the discussion. The Secretary, Dr. J. F. Walker, of Rocklands, Clifton Terrace, Southend-on-Sea, would be glad of suggestions of names of persons who have taken an active interest in this subject, in order that they may be invited to participate in the debate.

Meetings of Branches and Divisions.

KENT BRANCH.

THE annual report of the Branch Council for 1920 states that during the year twenty-five candidates were elected, and the membership is now eighteen more than last year. The Council met four times. There were four meetings of the Branch; at Margate, where the presidential address was given by Mr. W. G. Sutcliffe; at Dover, where Dr. Constant Ponder gave a paper on "Some links between the practitioner and the pathologist"; at Dartford, where Lord Dawson gave an address on "Primary health centres"; and at Maidstone, where Dr. W. H. B. Stoddart gave a lecture on "Psycho-analysis." The average attendance was over twenty-five. As a result of the Dartford meeting it seems likely that, at any rate in some parts of the county, steps will be taken to form representative advisory medical committees on the lines of the Dawson scheme. The Maidstone and Tunbridge Wells Divisions have each arranged a series of scientific meetings; these have been well attended, and the Council suggests again that this course will not only fulfil one of the objects of the Association but contribute to unity and good feeling. The Dover and Folkestone Division has recently been revived. The Canterbury and Faversham Division lost a very vigorous secretary after the war and has not yet found a successor. The Ashford Division has also lost a most useful secretary. The unorganized state of these Divisions has been considered at each meeting of the Council and various steps taken to awaken the interest of the members. The annual meeting of the Branch was held at Margate in June and was attended by twenty-two members; they were entertained to lunch by the President, who gave a graphic description of his "Experiences in a casualty clearing station."

NORTHERN COUNTIES OF SCOTLAND BRANCH: INVERNESS DIVISION.

At a meeting of the Inverness Division, held in Inverness on May 20th, when Dr. T. MACDONALD was in the chair, Dr. John Mauro Moir (Inverness) was elected Representative of the Division in the Representative Body 1921-22, and Dr. James Murray (Inverness) Deputy Representative.

The Report of Council *re* Federation (SUPPLEMENT, March 5th) was considered, and it was unanimously resolved:

That this meeting records its approval in the event of the British Medical Association becoming in part a federation, of the Draft Articles and By-laws, and recommends the Divisional Representative to support the same, if approved of, at the Annual Representative Meeting.

The Annual Report of Council was considered and the Representative was instructed to use his discretion regarding it at the Annual Representative Meeting.

SOUTH WALES AND MONMOUTHSHIRE BRANCH.

At the fiftieth annual meeting of the Branch, held at Cardiff, with the President, Dr. OWEN WILLIAMS, in the chair, the report of the Council and the financial statement were read and adopted. The membership was 603—an increase of forty-five during the year. Three meetings of the Branch were held during the year. At the spring meeting at Cardiff, when Mr. E. B. FURNER delivered an address on the Ministry of Health Bill, there was an attendance of forty-four members. The Branch Council met six times. The Treasurer's statement showed a balance in hand of £105.

The following were elected as officers for the year 1920-21:

President-elect: Dr. P. J. O'Donnell.

Honorary Treasurer: Dr. C. Biddle.

Honorary Secretaries: Drs. E. E. Brierley and D. R. Price.

A vote of thanks to Dr. Freeman Marks, who had acted as secretary for seven years, was carried with acclamation. Dr. OWEN WILLIAMS then introduced the new President, Mr. W. J. Greer, referring to the excellent work that he had done for the Association, and the high esteem in which he was held in London. The President then read his address, entitled "The First Minute Book of the Branch," which was most interesting historically, as well as instructive and amusing. The annual dinner—the first since 1914—was held at the Royal Hotel. The President and twenty-three members and friends were present.

A clinical meeting of the Branch was held at Royal Gwent Hospital, Newport, on February 24th, 1921. The President (Mr. W. J. Greer) and seventeen members were present. The President showed a number of x-ray photographs, microphotographs, and patients, and afterwards entertained the members to tea, and showed them round the wards and the new operating theatre. A cordial vote of thanks to the President was carried with acclamation.

A meeting of the Branch was held at the Swansea Hospital on April 8th, when twenty-one members were present, and Dr. A. CLARKE BEGG, in the absence of the President, took the chair. Cases, skiagrams, and papers were contributed. The meeting was most successful, the only criticism being that there were too many papers on the agenda, which necessitated rather short discussions.

A social meeting of the Branch was held at Caerphilly on May 26th, when members visited the Castle and were afterwards entertained to tea by Dr. and Mrs. Mackenzie. The annual meeting of the Branch will be held at Cardiff on Thursday, June 23rd.

MEETINGS TO BE HELD.

BIRMINGHAM BRANCH: CENTRAL DIVISION.—The annual meeting of the Central Division will be held at 18, Bennett's Hill, on Thursday, June 16th, at 3.45 p.m. Agenda: To instruct Representatives. To elect officers for ensuing year. Nominations for officers must be in the hands of the Honorary Secretaries fourteen days before the meeting. Members are requested to bring with them copies of the SUPPLEMENT of April 30th.

KENT BRANCH.—The eighth annual meeting of the Branch will be held on June 9th, at 2.30 p.m., at the London County Council Mental Hospital, Bexley, near Dartford. Agenda: To receive (a) report of the election of officers for 1921-22; (b) annual report and financial statement. To elect an auditor. Any other business. The Council will meet before lunch, and due notice, with agenda, will be sent to members of Council. The President-elect, Lieut.-Colonel T. E. Knowles Stansfield, C.B.E., kindly invites members to lunch at 1 p.m., at the hospital. The business meeting will be followed by the presidential address, entitled "Our 'C3' population." A garden party will be given by Mrs. Stansfield afterwards. Arrangements will be made for the entertainment of the ladies during the business meeting and the presidential address.

METROPOLITAN COUNTIES BRANCH.—The annual general meeting of the Metropolitan Counties Branch will be held at 429, Strand, W.C., on Friday, June 24th, at 4 p.m. Business: (1) Report of scrutineers as to the election of new officers. (2) Annual Report of Council. (3) Alteration in Rule 11 by the insertion of words providing that such members of the Branch as are members of the Central Council shall be *ex officio* members of the Metropolitan Counties Branch Council. (4) President's address by Dr. H. B. Brackenbury, on The Psychologist in Public Life.

OXFORD AND READING BRANCH.—The annual meeting of the Branch will be held at Maidenhead on Wednesday, June 29th, at the Town Hall. Any members wishing to show cases or read notes should communicate with Dr. E. W. Squire, 223, King's Road, Reading, before June 19th. Dinner will be arranged afterwards at one of the riverside hotels. Those intending to be present and having room in their cars or requiring a lift are asked to write to the secretary.

SOUTH MIDLAND BRANCH: BEDFORD DIVISION.—The annual meeting will be held on Thursday, June 9th, at 3.30 p.m., at the Bridge Hotel, Bedford, when the annual report will be presented and officers elected. Sir James Cantlie, K.B.E., will give an address. The Chairman, Dr. Street, invites the members of the Division to luncheon at the Bridge Hotel, Bedford, at 1.15 p.m.; members who wish to accept Dr. Street's kind invitation are asked to notify their acceptance not later than June 4th. An Executive Committee meeting will be held at 3.15 p.m.

SOUTH-WESTERN BRANCH.—The eighty-first annual meeting of the Branch will be held on Wednesday, June 15th, at the White Hart Hotel, St. Austell, at 3.15 p.m., when Dr. Jonas will resign the chair to Dr. Shaw, who will deliver his inaugural address. The report of the Branch Council for 1920-21 and the annual financial statement for 1920 will be presented and the Branch officers will be elected for 1921-22. Luncheon, by the kind invitation of the President-elect, will take place from 1 to 2.15 p.m., at the hotel. Dr. Shaw asks those intending to be present to send him written acceptance. The annual dinner of the Branch will be held at 7.45 p.m. at the hotel. Tickets, 10s. 6d. each (exclusive of wine), can be had from Dr. W. Gilchrist, High Cross House, St. Austell; early application is desired. Golf and bowls and excursions can be arranged. Mrs. Shaw will be at home at "Ardmore" at 4.30. Several St. Austell members are willing to accommodate visitors for the night, while there will also be accommodation at the hotel.

WORCESTERSHIRE AND HEREFORDSHIRE BRANCH.—The annual meeting of the Worcestershire and Herefordshire Branch will be held at the Infirmary, Worcester, on June 30th, at 3 p.m.

Association Notices.

REPRESENTATIVE MEETING.

DATE.

THE Annual Representative Meeting at Newcastle will begin on Friday, July 15th, 1921, at 10 a.m.

NOTICES OF MOTION AND AMENDMENT BY DIVISIONS
AND BRANCHES.

The Supplementary Report of Council to the Representative Meeting will appear in the SUPPLEMENT of July 2nd, 1921.

Notices of Motion and Amendment by Divisions and Branches for consideration by the Annual Representative Meeting will be published in the SUPPLEMENT as they are received, but none can be published later than July 2nd, for which purpose they must be received by the Medical Secretary not later than the first post on Monday, June 27th.

It will be possible, however, to include in the Agenda for the Annual Representative Meeting all Notices of Motion and Amendment which are received by the Medical Secretary *not later than the first post on Monday, July 4th, 1921.*

SCOTTISH COMMITTEE.

ELECTION OF DIRECT REPRESENTATIVES, 1921-22.

TWELVE members of the Scottish Committee of the British Medical Association are to be elected by the Scottish Divisions, grouped as follows:

	No. of Represent- atives.
GROUP I. The Divisions in the Aberdeen and Northern Counties Branches ...	2
GROUP II. The Divisions in the Dundee, Perth, Fife, and Stirling Branches ...	2
GROUP III. The Divisions in the Edinburgh Branch, and the Dumfries and Galloway Division ...	3
GROUP IV. The Glasgow City Divisions ...	3
GROUP V. The remaining Divisions in the Glasgow and West of Scotland Branch ...	2

Nominations may be made (a) by a Division or (b) by three members in a group. The election, in cases of contest, will be by postal vote of the members in each group.

Forms for nomination may be obtained from the Scottish Medical Secretary, 6, Rutland Square, Edinburgh, and must be returned to him not later than June 22nd.

COLONIAL MEDICAL SERVICES.

THE following further letter as to the Colonial Medical Services has been forwarded to the Colonial Office by the British Medical Association. In reply to a later inquiry, the Secretary of State has, on May 28th, informed the Association that he hopes soon to be in a position to reply to this previous letter of the Association. Some of the earlier correspondence was published in the SUPPLEMENT of November 27th, 1920, p. 141, and the general position was summarized in a Current Note in the SUPPLEMENT of April 9th, 1921.

British Medical Association, Medical Department,
429, Strand, May 3rd, 1921.

Sir,

With reference to my letters to you of October 15th and March 21st last, as to the uneasiness and dissatisfaction felt by the Association at the delay in dealing with the recommendations contained in the report of the Departmental Committee on the Colonial Medical Services, the Association trusts to hear further from you at an early date, pursuant to paragraph 3 of your letter of March 29th.

2. The Dominion Committee of the Association directs me to emphasize, as causes of unrest throughout the Colonial Medical Services, additional to the delay in dealing with the report of the Departmental Committee: (1) The poor advances in the salaries of the middle-service and senior men; (2) the failure to supplement adequately the pensions of the retired men; (3) the lack of proper hospital and dispensary provision and equipment; and (4) the need for a Medical Department of the Colonial Office.

3. Urgent representations as to the above continue to be received from Branches and members of the Association, representing practically all the areas under the control of the Colonial Office.

4. There is great discontent as regards the miserable increases made in the pensions of the retired men. On that question I am by instruction writing to you separately.

5. As the Secretary of State cannot but be aware, there are certain Colonial Services in which the discontent and dissatisfaction among the medical officers as regards the terms and conditions of service are specially grave—namely, the British Guiana, East African, Leeward Islands, West African and Windward Islands Medical Services.

I.—British Guiana Medical Service.

6. The discontent among the medical staff in British Guiana arises especially from the fact that there is apparently no provision for payment of passages of medical officers going on leave, or for study leave; that the prospects of promotion are extremely poor; and that the pension provision is reckoned in 160ths.

II.—East African Medical Services.

7. (a) *Salaries.*—Much dissatisfaction is felt that the increases of salaries given to the Medical Department do not conform to the increases given to the other departments, and this is especially marked when comparison is made with the increases in the salaries of the Legal Department. The Association desires to emphasize the recommendation it made to the Departmental Committee that the salaries of all medical officers should be increased by at least 50

per cent. on the pre-war scale, including emoluments. The Association would be glad to know how the increases of salary given to the staff of the Colonial Office at home compare with the increases of salary given to the officers of the East African Medical Services. Extreme discontent exists as regards the question of the "temporary non-pensionable local allowance." In the opinion of the Association it is essential that this question be faced at once. The present salaries are paid at 10 rupees to the pound owing to the arbitrary fixation of the local rupee value at 2s., instead of at 15 rupees to the pound, which is the correct exchange of the rupee at its true value of 1s. 3d. As a result, many officers' pay in rupees is less than it was before the war. For instance, the maximum total emoluments of the P.M.O. Uganda before July, 1914, were Rs. 12,750 per annum, while under the new arrangement the figure is Rs. 12,000 only. The anomaly has been met for the moment by the "temporary non-pensionable local allowance," but already rumours are current that that allowance will soon be removed or decreased. Since an officer's main expenditure must be based on the coinage of the country in which he lives, any such reduction in salaries would inevitably be followed by many resignations from the Medical Service. The anxiety and suspense felt by medical officers on this subject are prejudicial to the Service, both directly and indirectly. The Association urges that the salaries be fixed on a rupee basis for the East African Dependencies, and on a sterling basis for leave and pension.

(b) *Staff.*—The appointment of temporary medical officers, with no permanent interest in the country, on a scale equal to that of senior medical officers of ten and more years' approved service, cannot be regarded as other than an inequitable measure, or as one likely to allay the acute dissatisfaction now prevailing in the Service. The attempt to supply first, women doctors, and then Cingalese doctors (for both of whom the work is unsuited), naturally conveys the impression that the Colonial Office is indifferent to the institution of an efficient Medical Service, and is merely anxious to gain time in the hope that later, as more students qualify, medical officers can be obtained on cheap terms, irrespective of the obviously urgent consideration of the present efficiency of the Medical Services.

(c) *Prospects.*—The Association asks for better prospects for the medical officers, especially increase of the number of senior posts, and improved pay for the higher grades, from principal medical officer downwards.

(d) *Gratuity and Pensions.*—Much dissatisfaction is felt because the gratuity after twelve years' service is only £1,250, as compared with the gratuity of £1,575 recommended by the Departmental Committee, and that twenty years' service is proposed to be required to qualify for pension, as compared with eighteen on the West Coast. Do the gratuity arrangements mentioned on page 6 of the Colonial Office Memorandum 99 of September, 1920, hold good in respect of all the medical officers now on the permanent establishment? Is there now any bonus on the gratuity?

(e) *Age of Retirement.*—Speaking generally, medical officers, for obvious reasons, cannot join the service until about the age of 27, whereas administrative and other officers can often join at 23, and hence have the option of retiring at an earlier age than the medical officers. This should be taken into account as regards the Kenya Circular 46 as to new conditions of service.

(f) *Passages.*—In view of the small increase of salaries given, it is felt as a great grievance that the assistance towards passages of wives has been withdrawn. While the Colonial Office admits the principle that officers should be accompanied by their wives, as beneficial on the grounds of health and general efficiency, it appears to do nothing to encourage married men, either by the payment of passages or providing suitable housing accommodation for white women, with a reasonable amount of furniture in out-stations.

(g) *Study Leave.*—The Association considers that the tuition and examination fees should be paid in all cases of study leave, and not withheld when an officer takes a course involving an examination for a further degree or diploma. It is in the best interests of the Service to encourage men to present themselves for higher examinations, irrespective of whether they succeed or not. For obvious reasons, compulsory study courses should not be performed during the earned leave of an officer. The allowance of 5s. a night lodging, plus 5s. a night board is insufficient, especially in the case of a married officer. There is in the opinion of the Association no justification for withholding such allowances in the event of a medical officer failing to pass a high standard examination. It is a step likely to defeat the object the Colonial Office is supposed to have in view—namely, the raising of the standard of the men who form the Medical Service.

(h) *Honours.*—A very natural resentment is felt by members of the Medical Service because honours are given much more freely to persons in Government employ at home, and to the legal and administrative departments in Eastern Africa, than to the medical officers in these Protectorates.

(i) *Shortage of Staff.*—The present position in this respect in some of the Protectorates is deplorable, and against the interests of all concerned. In the opinion of the Association the only remedy is fair terms and conditions of service for the medical staff. The unrest and dissatisfaction in this Service in particular, but also in practically all the Colonial Medical Services, are such as to act as a very effective check on recruiting. Like the Departmental Committee the Association considers (1) that the terms and conditions should be improved so as to attract the right type of medical men, and that then

(2) the medical officers should be most carefully selected. At the present time it is clear that the Colonial Office finds it practically impossible to obtain good men for these Services, and, as a result, welcomes practically any candidate, irrespective of age and other qualifications, with the result that a vicious circle is being established. The ideal is that the Colonial Medical Services should offer conditions comparable to those of the I.M.S. and the R.A.M.C.

(j) *Scope of Work of Medical Staffs.*—Are the officers of the East African Medical Services intended for the treatment of Government employees only, or for the whole native population? If the latter, the Association would be glad to be furnished with a statement of the average number of medical officers and of hospital beds available per 1,000 of the native population.

Zanzibar Protectorate.

8. The Association desires to draw the attention of the Secretary of State to the financial loss suffered by the medical officers of the Zanzibar Government Service owing to the varying rates of exchange of the rupee. In the other protectorates in Eastern Africa where the rupee is the current coin—namely, Kenya, Tanganyika, and Uganda—the rate of exchange has been fixed by the Government at Rs. 10 to the £, but in Zanzibar this follows the Indian rate, and owing to the steady depreciation of the rupee the exchange has gradually fallen to Rs. 14½ to the £, and will probably reach Rs. 15, the old pre-war rate. In other words, to transmit £1 to England costs in Kenya Rs. 10 and in Zanzibar Rs. 14½. In the Colonial Office Memorandum No. 99 of September, 1920 (page 6, para. (iv)), it is stated that an official receives a local allowance of 50 per cent., in that his salary is paid at Rs. 15 to the £ and the exchange rate is fixed at Rs. 10 to the £. It has been pointed out *ad nauseam* that in any case this is not a true 50 per cent. allowance, as the purchasing power of the rupee does not vary with the exchange rate, and that the 50 per cent. allowance only applies to that portion of his salary an official can transmit to England. But even this does not hold good in Zanzibar, as drafts are practically at par or Rs. 15 to the £, and the most one can profit on exchange is about 3 per cent. As it is necessary for most of the Zanzibar medical officers to remit money to England for various purposes, they are placed at a serious disadvantage financially compared with their colleagues in the rest of Eastern Africa, and the Association considers the position to be very unfair. A memorandum has, the Association understands, recently been signed by all officers in the Zanzibar service, raising this question and asking for alleviation, present and retrospective. The reply to this has apparently been that the petition will be forwarded to the Secretary of State for his consideration. Apparently months may thus be allowed to elapse before a reply is received, and the financial loss continues. When it is borne in mind that the loss in remitting home £200 per annum (and many have to remit much more) is roughly from £75 to £100, the gravity of the situation will be realized.

III.—Leeward Islands Medical Service.

9. The Association would be glad to learn what action has been taken by the Colonial Office to remedy the deplorable state of matters as regards pay, leave, prospects, housing and travelling allowances, and insufficient staff, to which the medical officers of Antigua and the Association have already drawn the attention of the Secretary of State. The Association has addressed to you, on April 23rd, a separate letter as to the case of Dr. A. J. Gibson, who, in the opinion of the Association, rightly resigned forthwith, on arrival in Antigua, the post of Medical Superintendent of the Hospital and Health Officer there, to which he was appointed in December, 1919.

IV.—West African Medical Staff.

10. The Association has lately received still further representations from members and groups of members of the Association in the West African Medical Staff, complaining bitterly of the delay as regards action on the recommendations of the Colonial Medical Services Committee. Grievances specially mentioned as affecting medical officers in that Staff are as to salaries (especially the salaries of the higher posts), seniority, gratuities, pensions and housing. A man selected for specialist appointment should rise at least to the pay of P.M.O. without being obliged to take up administrative work. It is keenly resented by medical officers that these members of the medical profession should necessarily take precedence after puisne judges, senior political officers, senior clerks, battalion commanders, captains or majors. Local members of the Association point out that the average number of years' service before promotion to Senior Medical Officer is now increased from seven to fourteen years, and that confidential reports are still not shown to the medical officers concerned. In the Colonial Office Memorandum 678 as to West Africa, of August, 1920, it was stated that alterations in the West African Regulations as to leave and pensions were under consideration. The Association would be glad to be informed what the result of this consideration has been. Is there now any bonus on the gratuities mentioned in page 7 of that Memorandum (paragraph 40)?

V.—Windward Islands Medical Service.

11. The Association was greatly surprised to learn from your reply of March 29th last (No. 13746) that the Colonial Office had not by then received the petition of the medical staff of Grenada, forwarded in December last to the Secretary of State through

the Governor, as to the many and urgent grievances under which these officers are suffering. These included: (a) inadequacy of the salaries of the district medical officers (basic £250, plus 10 per cent.—that is, £275); (b) insufficient forage allowance (£50); (c) no house allowance or free quarters; (d) stationary character of the salary; (e) no promotion; (f) invidious treatment of the medical staff; (g) transference of control from the Colonial Surgeon to the Governor; (h) the heavy and ill-rewarded work imposed upon the profession by the Venereal Disease Ordinance and otherwise; and (i) the general conditions of service. The district medical officers had hoped that the recommendations of the Departmental Committee would have led to immediate amelioration of the terms and conditions of service, which in the opinion of the Association are discreditably. It is obvious that the medical officers did not realize how slow are the methods of the Colonial Office. The Association urges that the petition, and the further petition dated February 28th, have the immediate attention of the Secretary of State.

Mesopotamia.

12. The Association will be obliged if you will kindly state, if known, or known approximately, for what length of time British medical officers are likely to continue to be employed in Mesopotamia. The Association understands that the mandated territories are to be administered by the Colonial Office.

Publication of Evidence given before Colonial Medical Services Committee.

13. In conclusion, I am instructed to ask why the evidence given before the Colonial Medical Services Committee appointed by the late Secretary of State has not yet been published. If on the ground of economy, the Association protests against this course, as one which is far from being a real economy in view of the urgent public interests involved. Is it intended to publish the evidence, and when?

14. I am further instructed to say that we cannot much longer delay action on behalf of our members whose interests are concerned. Prompt action by the Colonial Office in dealing effectively with the recommendations of the Colonial Medical Services Committee, the Association will, with regret, find itself obliged to advise its members and those who rely upon it for advice in such circumstances, that they will not be consulting their own interests or those of the profession or the public in entering the Colonial Medical Services, until they are radically improved.

I am, Sir, your obedient servant,
(Signed) ALFRED COX,
Medical Secretary.

The Under-Secretary of State,
Colonial Office.

DANGEROUS DRUGS REGULATIONS.

THE action taken by the British Medical Association in regard to the draft Dangerous Drugs Regulations, issued in January by the Home Office, was fully recorded week by week in the SUPPLEMENT during February and March, and the story was told again in brief in paragraph 213 of the Annual Report of Council (SUPPLEMENT, April 30th, 1921, p. 129). The prompt and energetic representations made by the Association, acting in concert with the Pharmaceutical Society and other kindred interests, resulted in the withdrawal of the original draft Regulations and the setting up by the Home Secretary of a Committee to advise him on the subject. The reference of the Committee was:

"To consider outstanding objections to the draft Regulations under the Dangerous Drugs Act and to advise what modifications can safely and properly be made, having regard to the main principles on which the Regulations are based, and which are essential in the public interest for safeguarding the use of the drugs."

The Committee's report has now been issued as a Parliamentary White Paper.¹ An appendix contains the amended Regulations submitted by the Committee, which have since been accepted by the Home Secretary and published in the *London Gazette*. These two documents—the Report and the revised Regulations—form together a striking vindication of the action of the British Medical Association and of the bodies associated with it in this matter. All the objections put forward by the Association have been considered worthy of careful consideration and discussion, and most of them have been met.

After stating the nature of the main objections to the draft Regulations raised by the British Medical Association and the pharmaceutical bodies, the Committee sets out in general terms the way in which it proposes to meet these

objections, "so far as can be done without weakening the safeguards essential for the protection of the public." The drugs to which the Regulations apply are morphine, cocaine, ecgonine and diamorphine (heroin) and their respective salts, and medicinal opium, and any preparation containing not less than one-fifth per cent. of morphine, or one-tenth per cent. of cocaine, ecgonine or diamorphine.

"It appears," says the Committee, "that the only legitimate use which members of the general public can have for these drugs is a medical one, and, as a general rule, only a duly qualified medical practitioner can say whether they ought to be used in any particular case or not. Further, we are not able to agree that the present conditions imposed on the sale of these substances by the Pharmacy Acts are sufficient. . . . In the absence of any practicable alternatives, we have no hesitation in expressing the opinion that in view of the dangerous properties which these drugs possess, they should not be issued to members of the public except under medical direction, and we recommend that the principle of requiring a doctor's prescription should stand. That is the view which is strongly held by the British Medical Association itself, whose representatives appeared before us."

The Committee next considered the feasibility of admitting exceptions to the general rule in the case of any familiar remedies. The representatives of the British Medical Association and the Pharmaceutical Society were asked to suggest the preparations which might be exempted; these are the basis of a list of seventeen exemptions appearing in Schedule 2 to the amended Regulations. It includes such well known remedies as Dover's powder, gall and opium ointment, and preparations of lead and opium. The preparations exempted are:

Cereoli iodoformi et morphiinae, B.P.C.
Emp. opii, B.P. 1838.
Lin. opii, B.P.
Lin. opii ammon., B.P.C.
Pasta arsenicalis, B.P.C.
Pil. hydrarg. c. opio, B.P.C.
Pil. ipecac. c. scilla, B.P.
Pil. plumbi c. opio, B.P.
Pil. digitalis et opii co., B.P.C.
Pil. hydrarg. c. cret. et opii, B.P.C.
Pulv. cretae arom. et c. opio, B.P.
Pulv. ipecac. co., B.P. (Dover's powder).
Pulv. kino co., B.P.
Suppos. plumbi co., B.P.
Tabletæ plumbi c. opio, B.P.C.
Ung. gallae c. opio, B.P. (gall and opium ointment).
Ung. gallae co., B.P.C.

In order to minimize the risk that prescriptions may be forged or fraudulently copied the Committee suggests that as a general rule prescriptions for drugs covered by the Regulations should be required to be made on an official form. Since prescriptions for insured persons are already written on official forms provided by Insurance Committees, it would only be necessary to extend the use of an official form to prescriptions for these drugs given otherwise than under the Insurance Acts. When in an emergency an official form is not at hand, it is recommended that the prescriber may do without it, provided that (1) he marks the prescription to show that an official form is not available; and (2) it may only be made up by a chemist who either is acquainted with the practitioner's signature, or who is acquainted with the person for whose use the prescription is given and has no reason to doubt its genuineness. In order to secure that forms may be obtainable by all duly qualified medical practitioners, and by them alone, the Committee expresses the hope that the Treasury will see its way to supply them to medical practitioners without charge through the agency of some Government or other public authority.

Provision is made for the administration of "the drugs" by an authorized person in the absence of the doctor so long as a prescription is written and the usual cross-reference made (see section headed "Records" below). The former ambiguity which existed as to whether or not a messenger could legally have possession of "the drugs" for the purpose of transmission between the doctor and patient, or the chemist and patient, is cleared up. Again, the Committee has upheld the contention of the witnesses of the Association that it would be an injustice to grant by way of a sideward the desire of the chemists to insist that no doctor should dispense his own prescriptions for any of "the drugs," but that such prescriptions should in all cases be dispensed by a pharmacist.

In comparing the Regulations as now issued with the draft to which objection was taken by the British Medical Association, the following further points may be noted:

¹Cmd 1307. To be purchased through any book-club or directly from H.M. Stationery Office. Price 3d. net.

Personal Administration.

The draft Regulations left it uncertain whether or not when a practitioner personally administered one of "the drugs" he was bound to keep a full record in the shape of a prescription and an entry in one of the various books. It is now made clear that direct administration to a patient does not involve either prescription or record.

Prescription.

Formerly the prescription had to contain not only the signature and address of the practitioner, but his qualifications, and he had to write the words "not to be repeated." The requirements as to qualifications and "not to be repeated" are omitted. The Secretary of State may issue an official prescription form in the manner described above, and if he does the form must be used whenever "the drugs" are prescribed at or above a strength of one-fifth per cent. of morphine or one-tenth per cent. of the other drugs, except in emergencies. "The drugs" can only be supplied once on the same prescription unless the doctor directs in writing that they may be supplied on not more than three occasions. In this event he must specify the intervals at which the prescription is to be dispensed. The prescription must be retained by the chemist, so that the repeated supply can only be given by that chemist.

The requirement to which the British Medical Association took the strongest exception in the draft Regulations was that the total amount of the drug and the percentage in any solution should be stated on the package. This is abandoned when the preparation dispensed is on the prescription of a duly qualified medical practitioner.

Records.

The draft Regulations required the practitioner to keep separate books for registering all purchases of "the drugs," one for cocaine and ecgonine and substances containing them, one for morphine and substances containing it, another for diamorphine and substances containing it, and another for medicinal opium. He is now required to keep a record of the supplies of "the drugs" purchased or otherwise obtained by him in a book, and he must keep the records of "the drugs" mentioned above in separate parts of the book in the form shown in Schedule I; this must show the date on which the supply is received, the name and address of the person, body, or firm from whom obtained, the amount obtained, and the form in which obtained.

In the draft Regulations the practitioner was required to enter the record of "the drugs" purchased or otherwise obtained, on the day on which the drug was received. He is now allowed to enter the transaction on the following day if it is not "reasonably convenient" to do it on the day of the receipt.

Instead of keeping the elaborate register of "the drugs" supplied to patients, showing the date on which the transaction was effected, the name and address of the person, etc., to whom sold or supplied, the authority of the person, body, or firm to be in possession of "the drug," the amount sold or supplied, the form in which sold or supplied, and the ingredients of the prescription when the sale is on a prescription, the dispensing doctor is now required only to make the usual entry of the prescription in a day book and to have a cross reference (a sort of index) to these prescriptions in some other book, keeping the references to the use of the different drugs separate one from the other.

The witnesses of the Association stated their opinion to the Committee that, greatly attenuated as the new form of record is, and thereby rendered much less obnoxious, it will, in their opinion, be useless for the purpose of checking abuse. They made it clear that this was said not with a desire to be obstructive, but because it appeared that the Regulations were based on a desire to secure a record of all incoming and outgoing of "the drugs," and now that that idea had been abandoned the record merely of a minute proportion of the "outgoings" would be useless. The reply of the Committee, in para. 3, p. 5, of the Report seems unconvincing:

"3. In the objections originally submitted to the Home Office a strong protest was made by the British Medical Association, the Pharmaceutical Society, and other interests, against the unnecessary trouble that would be entailed by the keeping of the records required by the draft Regulations. It was assumed that the object of the records was in all cases to enable a kind of balance to be struck between the quantities of the drugs received and the quantities disposed of, and so to make it possible to trace leakages of the drugs; and it was felt that such a scheme was impracticable, and the trouble entailed would serve no useful purpose. We agree that a record of incoming and outgoing on these lines in the case of a dispensing doctor or chemist cannot be required—and, as we understand, was never contemplated—for the reason that the records cannot be required to give particulars of preparations which contain the drugs in quantities less than the minimum limits specified in the Act. But we do not agree that the records required by the Regulations are useless. On the contrary, we think it essential that records should be kept of transactions in the drugs. They are obviously essential for purposes of administration, to enable investigations to be made when any question arises as to the use of the drugs in any particular case or cases; they will serve as a final check on careless or illegitimate dealings in or prescribing of the drugs; and they will furnish

valuable information as to the extent to which the drugs are used in the strengths covered by the Act. We think, however, that it is possible to reduce considerably the trouble entailed on the dispensing doctor or chemist without weakening the value of the record as a safeguard. Every doctor keeps, or should keep, a day book, in which he enters particulars of the medicines supplied to his patients, and every chemist is required by the Pharmacy Acts to keep a 'poison book' and a 'prescription book.' We think that the entries of the necessary particulars in the day book or the poison or prescription book, as the case may be, should be accepted as giving the information required, and all that is necessary in addition is that an index should be kept giving the references to the entries in the day book or the poison or prescription book which relate to the drugs. This is embodied in the amendments which we have proposed. No further objection is raised on this point by the Pharmaceutical Society in their letter to the Committee, and the British Medical Association admit that a record in the form now proposed will give little work to the average practising doctor. Dr. Cox, however, still urges that this record should not be required in the case of a medical practitioner who dispenses his own medicine. He contends that it will be useless and will be recognized as such by every dispensing doctor. For the reasons stated above, we think that the record will be valuable and we cannot recommend that it should be dispensed with in the case of a doctor. We may observe that the keeping of records has been required for some years past in the case of prescriptions containing cocaine."

GENERAL COUNCIL

OF

MEDICAL EDUCATION AND REGISTRATION.

SUMMER SESSION, 1921.

Sir DONALD MACALISTER, K.C.B., President,
in the Chair.

DANGEROUS DRUGS REGULATIONS.

THE PRESIDENT introduced the report of the Pharmacopoeia Committee, which principally referred to the action taken by the Council in connexion with the new draft Regulations under the Dangerous Drugs Act. Sir Donald MacAlister said that the committee, on hastily going through the first draft of the Regulations, discovered a number of points on which objections should be raised. The committee also asked other members of the Council to communicate any point which seemed open to criticism. These objections and suggestions were then formulated and sent to the Home Secretary, and one or two interviews took place with officials of the Home Office in which attention was drawn to these matters. He understood that other bodies, including the British Medical Association and the Pharmaceutical Society, also had serious objections which they advanced. Ultimately the Home Secretary found the number and weight of the objections so considerable that he set up a special committee, to which body the Pharmacopoeia Committee of the Council furnished evidence. The revised Regulations had now been published, and so far as could be seen they met the points which the Pharmacopoeia Committee had advanced. He could not, of course, state what was the view of the other bodies which had put forward objections, but the Regulations as now modified gave effect to everything that his committee had represented.

The report which he presented also dealt with the report of the Ministry of Health Committee on the biological control of certain therapeutic substances. The recommendations of the Government Committee were in general accord with those submitted on behalf of the Council in 1909. It was proposed to establish a Privy Council committee as controlling authority; to appoint an advisory committee of experts, on which the General Medical Council should be represented; to provide a central laboratory under the Medical Research Council, and institute a system of licensing, inspection, and testing of samples which would ensure to the public that the therapeutic serums and other preparations offered for sale were of the prescribed quality. While the central laboratory would have no monopoly in the manufacture of these substances, it would have the inspection and control of them in the same way as the National Physical Laboratory dealt with thermometers. The proposals would require legislation before they could become operative, and there would be ample time to consider the changes in the text of the *Pharmacopoeia* which would be necessary when these recommendations were passed into law.

Sir NORMAN MOORE seconded the reception of the report.

Mr. E. B. TURNER said that he had intended to ask the President a question on the Dangerous Drugs Regulations, but his remarks had rendered it unnecessary. What the President had said would clear away certain misapprehensions among the profession with regard to the action of the General Medical Council on this matter. It was the speaker's duty as chairman of the committee of the British Medical Association which had this matter in hand to convey to the proper quarters certain objections taken by his committee to the Regulations in the form in which they were laid on the table of the House. Among the criticisms so advanced was one that the Regulations had been put forward without consultation with the medical profession. A letter appeared in the *Times* from Sir Edward Troup stating that the General Medical Council had given its approval, and in consequence of this he (Mr. Turner) received many letters in his dual capacity of chairman of the British Medical Association committee and member of the General Medical Council asking what was the position of the Council in the matter. He replied—and he thought his reply was the correct one—that doubtless the matter had been referred to the appropriate committee of the Council, but that as there had been no session of the full body it could not have approved or disapproved of them; he added in his reply that he was sure that the Council would appreciate that, as first published, the draft Regulations were not really workable or proper. He therefore had a special reason for desiring that the President's statement that the General Medical Council through its committee had not approved of the whole of these Regulations as first laid on the table of the House should be circulated as widely as possible, for it would remove a good deal of misapprehension.

The PRESIDENT said that the Regulations which came to the Council in the first instance were formal draft regulations, and as the Council was constantly receiving drafts of this kind in the early stage from the Government, it was assumed that in this case also they were sent for the Council's observations, and the Council had expected to receive the draft as amended before it was published. But apparently, in this case, there was a confusion between the draft Regulations and the final Regulations.

Dr. MACDONALD heped the President's statement would be as widely circulated as possible. He wished he could be quite as certain as the President was that the difficulty arose out of a mere mistake on the part of a Government official.

The report was then received and entered on the minutes.

PENAL CASES.

The Council on May 24th considered the following disciplinary cases:

Misdemeanours.

The Council considered the case of Frederick Percy Richard Gover, registered as care of a firm in West Smithfield, L.R.C.P. Edin., L.R.C.S. Edin., L.R.F.P.S. Glas., 1910, who was summoned to appear on the charge that, being a registered medical practitioner, he had been convicted of certain misdemeanours. On three occasions between June, 1916, and April, 1917, he had been convicted of being drunk in charge of a motor car, fined in the first two instances, and in the third instance sentenced to one month's hard labour, which was modified on appeal to one month's imprisonment in the second division. In November, 1920, he was convicted at the London Sessions of having caused bodily harm to a woman by wilful misconduct or by wilful negligence whilst having charge of a motor car, and was ordered to be imprisoned for three months in the second division.

The Council's Solicitor (Mr. Harper) stated the facts of the case, and said that after the third conviction, in 1917, the defendant received a warning from the Council. On the occasion of the last conviction the judge, in passing sentence, said that he would take into consideration the fact that Dr. Gover was unwell at the time, and that therefore a small quantity of alcohol might have had the greater effect upon him. Dr. Gover at one time had 5,500 insured persons on his list, and there had been no complaint against him professionally. He bore a high reputation for kindness and attention to his patients. All the offences were committed outside the district in which he practised. A committee of the Ministry of Health had inquired into the case, and expressed the view that although there was no suggestion that Dr. Gover had ever been the worse for drink while attending his patients, unless he abstained from alcohol it was not improbable that his continuance on the panel would be prejudicial to his patients' interests. The committee did not wish it to be thought that an offence in a doctor could be overlooked or condoned merely because the patients or insured persons on the doctor's list were not directly concerned. In view of the findings of the committee the Minister of Health

had deferred his decision for twelve months, and would have regard to Dr. Gover's conduct in the interval.

Dr. Gover, in evidence, admitted the convictions, and said that on the occasion of each offence he was away from his practice on holiday. He had taken an oath before the inquiry committee to abstain from alcohol for life, and also never to drive a motor car again. After the previous warning of the Council he had abstained from alcohol, and nothing had happened for three years, when, being seriously unwell, he took a little brandy and port, and the accident happened. He paid the injured woman £320 as compensation, none of which he received—or claimed for—from any insurance company. At the present time he had 1,545 insured persons on his list in West Ham. While in prison a petition in his favour was signed by 5,000 persons in his locality, many of whom were his patients, and a second petition by the police; these petitions were inspired by a remark by counsel in the proceedings that in the event of conviction he would be struck off the *Medical Register*.

Mr. Watts, Dr. Gover's counsel, laid stress on the point that although Dr. Gover attended such large numbers of that most capricious class of people—insurance patients—not a single complaint had been lodged against him.

The Council deliberated in private, and the PRESIDENT announced the decision as follows:

Mr. Gover: I have to tell you that the alleged convictions against you in the notice have been proved to the satisfaction of the Council. These convictions indicate a habit which is not only discreditable to your profession but may become dangerous to your patients. In order to give you an opportunity of reconsidering your habit in this matter the Council has postponed judgement on the convictions proved against you till the May session, 1922. Before that date you will be required to send to the Registrar of the Council the names of some of your professional brethren who may be willing, upon written application from the Registrar, to testify by letter addressed to him for the use of the Council as to your character and conduct in the interval. You will receive in due course a formal written intimation of what I have just announced to you, and the intimation will specify the date to which I have referred, when you should be present, and should understand that in the event of any further conviction for a similar offence the Council may instruct the Registrar to erase your name from the *Medical Register*.

On invitation from the chair, Mr. Gover renewed his solemn undertaking to refrain from drink for the rest of his life.

Misleading Certificate.

The Council considered the case of Clement Thomas Cory Kingdon, registered as of 62, Falcon Road, Clapham Junction, M.B., C.M. 1893, M.D. 1905, U. Edin., who was summoned on the charge that on February 7th, 1921, he signed and gave to one McKernon, an ex-soldier in the Australian Imperial Force, a certificate dated February 5th, 1921, to the effect that McKernon was suffering from influenza and was at present—that is, on February 5th—unable to travel, whereas he had neither seen nor examined McKernon on February 5th, or at all before February 7th.

The complainants were the Australian Imperial Force, represented by Major E. W. Morris, Senior Medical Officer at Australia House, and Dr. Kingdon was represented by Mr. Hempson, who was instructed by the Medical Defence Union.

For the complainants it was stated that McKernon, at that time residing in Battersea, was in the early part of this year an insured person on Dr. Kingdon's list. He was also an ex-member of the Australian Imperial Force, and as such he had applied to the Australian authorities for a free passage to Australia under their repatriation scheme. It was arranged that he should embark at Liverpool on February 5th, but he did not do so, and on February 7th he sent to the Commonwealth authorities a medical certificate, dated February 5th, stating, "This is to certify that W. McKernon is suffering from influenza and is at present unable to travel." Something ambiguous in the certificate led to inquiries being made by Major Morris, who interviewed McKernon and Dr. Kingdon, and found that the certificate was actually issued on the 7th and undated to the 5th. The Australian authorities spent great sums of public money in repatriating ex-soldiers, and it was very necessary that they should have medical certificates on which they could place reliance.

McKernon was not available to be called as a witness, but a statutory declaration by him was read, in which he said that he told Dr. Kingdon that he was supposed to have sailed for Australia on the 5th, and asked him if he would give him a certificate for that day, and he paid him sixpence for the copy of it.

Major Morris, in evidence, said that when he saw McKernon on February 7th he could not see anything wrong with him, and as medical officer he offered to examine him, but the man said he was quite all right.

Dr. Kingdon, in evidence, said that he had been in practice in Battersea for twenty-two years. He had 2,500 insured persons on his list, and had never had any certificate called in question. During the war he had many applications for certificates to excuse overstayed leave, and was particularly careful not to grant certificates unless he was sure that the condition of the person merited them. On February 7th, McKernon came to him, explained that he was on his list, and stated that he was to have sailed for Australia on February 5th but was in bed ill on that day and also on the day following. It never occurred to the witness that this was a military case, but he thought it probable that the man was having an assisted passage from one of the emigrating agencies. He found the man's pulse rapid, with low tension, his skin hot and clammy, and he had no hesitation in giving him a certificate, but he

mitted to indicate that it was given on the 7th for the 5th. The mistake was made in good faith. He had no doubt whatever that the man was unfit to travel on the 5th. He had never antedated a certificate before.

Two medical practitioners in Dr. Kingdon's neighbourhood who had known him for many years testified to his high character and unsullied reputation.

Mr. Hempson said that whatever judgement might be passed upon the doctor's carelessness this was certainly not, as stated in the charge, infamous conduct in a professional respect. He was afraid that certification had become a little lax since the introduction of the Insurance Act, and that many practitioners dated back a certificate by a day in order to enable a patient to receive benefit. He did not excuse the practice.

The Council's decision, after private deliberation, was announced by the PRESIDENT as follows:

Mr. Kingdon: I have to inform you that the Council has found that the facts which were alleged against you in the notice of inquiry—namely, "That being a registered medical practitioner, you, on February 7th, 1921, signed and gave to one W. McKernon, ex member of the Australian Imperial Force, a certificate dated February 5th, 1921, that the said W. McKernon was suffering from influenza and was at present (that is, on February 5th, 1921) unable to travel, whereas you had neither seen nor examined the said W. McKernon on February 5th, 1921, or at all before February 7th, 1921"—have been proved to its satisfaction, but that the Council has taken into consideration the evidence as to your previous good character and your assurance that the certificate was given without due care and thought. In order to give you an opportunity to rehabilitate your character and to prove to the Council that you realize the gravity of your offence, and in particular in regard to the giving of certificates, the Council has postponed judgement till the November session, when you will be required to attend and to produce evidence from your professional brethren regarding your character. Before that date you will be required to send to the Registrar of the Council the names of some of your professional brethren who may be willing, upon written application from the Registrar, to testify, by letter addressed to him for the use of the Council, as to your character and conduct in the interval. You will receive in due course a formal written intimation of what I have just announced to you, and the intimation will specify the dates to which I have referred.

The PRESIDENT tendered to Major Morris, Major Best, and to the Australian Imperial Force the thanks of the Council for the assistance which had been rendered in placing the facts before it.

False Pretences and Fraudulent Conversion.

On May 25th the Council considered the case of John Thomas Godfrey, of Royton, Oldham, M.B., Ch.B. 1917, U. Edin., who was summoned on the charge that, being a registered medical practitioner, he was convicted at the Manchester Assizes held on November 15th, 1920, of attempting to obtain money by false pretences and fraudulent conversion of goods, and was ordered to be imprisoned for three months.

Mr. Harper, the Council's solicitor, stated that there were six charges in the indictment, all arising out of defendant's insurance practice. Three of the charges related to fraudulent conversion of goods for defendant's own use; the goods were cotton-wool, bandages, liniments, and sundries, the property of the Lancashire Insurance Committee, and the other three were charges of attempting to obtain certain small sums of money from the Committee for attendance upon disabled soldiers or sailors under the scheme of treatment for those persons when, as a fact, this service was not rendered. There was a direct conflict of evidence between witnesses at the trial, and an inquiry was held by the Ministry of Health, when no witnesses were called on the side of the prosecution, but Dr. Godfrey himself gave evidence at considerable length. The Committee reported itself not able to accept Dr. Godfrey's assertion of innocence on his unsupported testimony, and in consequence of the report of the Committee the Minister had removed Dr. Godfrey's name from the panel.

Mr. J. D. Lustgarten, counsel for Dr. Godfrey, said that the conviction could not be disputed, but the Council might surely exercise its discretion before taking any further action based merely on the fact of conviction. A legal argument ensued as to the limits of the Council's powers in the case of a conviction, and the President said that, while ready to bear anything in extenuation, the Council could not re-try the case. Mr. Lustgarten went on to say that Dr. Godfrey was an Indian, born in Durban, South Africa, and was 35 years of age. He acquired a practice, partly private and partly insurance, at Royton in 1917. Like some others, he found the insurance regulations not sufficiently explicit to enable him to see clearly what was his duty in every instance. It had been the practice in the locality—he did not say it was a proper practice—for doctors to provide from their own stores drugs and materials, not only in emergency cases, but in ordinary cases, and subsequently to obtain goods themselves from the chemist in replacement of those which they had issued. The three cases of alleged false pretences each related to a soldier or sailor treated under the special arrangement, and it was said on behalf of the prosecution that the service in respect to which these charges were made had not in fact been rendered. The evidence, however, was conflicting, and was not repeated at the Ministry of Health inquiry. But there were almost as many witnesses on the one side as on the other, and therefore when the committee spoke of the unsupported testimony of Dr. Godfrey it overlooked the fact that his testimony had been supported in the court. There were certain circumstances of prejudice imported into the case which could not be disregarded, owing to the fact that the practitioner was a man of colour. The motive was clearly inadequate, for the amount involved in all the charges did not total to more than £5. Counsel put in a number of written

testimonials as to character, including those of Dr. J. S. McGowan, Honorary Surgeon at Oldham Royal Infirmary; Dr. J. Lorrain Smith, under whom Dr. Godfrey studied at Edinburgh; the Chairman of the Royton Local District Council, and the Roman Catholic priest. Dr. Godfrey still retained the confidence and respect of those in his neighbourhood.

The Council considered the case in private, and on the readmission of the public the PRESIDENT announced the judgement of the Council as follows:

Mr. Godfrey: I have to inform you that you having been proved to have been convicted of the misdemeanour alleged against you in the notice of inquiry, the Registrar has been directed to erase your name from the *Medical Register*.

Disposal of Dental Practice.

The Council considered the case of George Ormiston, upon which the Dental Committee submitted a report. Mr. Ormiston did not appear, and a medical certificate stated that he was unable to travel owing to physical infirmity. The report of the Committee stated that Mr. Ormiston was registered in 1878, and his address in the current *Dentists Register* was at 170, Skene Street West, Aberdeen. At that address his name until recently appeared in conjunction with that of a Mr. Thow, and in the local press advertisements and the telephone directory the name was published as "Ormiston and Thow, Surgeon-Dentists." Mr. Thow, who had never been on the *Dentists Register*, was trained by Mr. Ormiston as a pupil, and had been in his employment for twenty years. He was said by Mr. Ormiston to be a most skilled operator and mechanic, and Mr. Ormiston had had to make use of his services owing to his own failing health. Mr. Ormiston, according to a letter received from his solicitors, had finally retired from dental practice, had withdrawn his name from the address in Aberdeen, and all financial and professional connexion between himself and Mr. Thow had ceased, with the exception that the latter had still to pay for the fixtures, furnishings, and material identified with the practice. The Dental Committee of the Council inferred that on receipt of the notice of inquiry he had parted from his practice to Mr. Thow for a consideration, and that this had not yet been fully discharged.

Mr. Hugh Atkins, the general secretary of the British Dental Association, who had lodged the complaint in this case, did not desire to address the Council, and after the facts had been stated, the Council deliberated on the case in private. On readmission of the public, the PRESIDENT announced that, the facts contained in the report having been proved, Mr. Ormiston had been found guilty of conduct infamous or disgraceful in a professional respect, and the Council had directed the Registrar to erase his name from the *Dentists Register*.

INSURANCE.

LOCAL MEDICAL AND PANEL COMMITTEES.

KENT.

THE following resolutions relating to Insurance Medical Records were passed at a meeting held on May 19th:

That the Kent Local Medical and Panel Committees object to the new records cards principally on the following grounds: (1) That a reasonable degree of secrecy cannot be guaranteed so long as the cards can be called for in a court of law, pass through official hands in transit from one doctor to another, and are filed with the names attached after final surrender. (2) That the A.V.C. columns are in effect of no value except as a time sheet, but nevertheless take up a great deal of time to complete, and in many cases require clerical assistance if they are to be correctly used, and moreover duplicate information as to certificates which is already in the hands of approved societies. (3) That the size and shape of the envelopes are open to considerable objection. (4) That the arrangements for paying the cost of postage are quite needlessly complicated and likely to result in loss to the practitioner. (5) That the record of transient affections—for example, dyspepsia, bilious attacks, cataracts—are of no value, and are merely waste of the practitioner's time and energies—(doctors would be willing to co-operate in providing notes of diseases where real value would be obtained.)

The Local Medical and Panel Committees for the County of Kent have also had under their consideration the circular letter of the Ministry of Health dealing with emergency treatment and anaesthetist's fees (SUPPLEMENT, April 16th, 1921, p. 99). The Committees decline to accept the inference to be drawn from Clause 2, para. (a) of this letter that services rendered in hospitals and similar institutions can be held to be within the terms of service and so can be remunerated out of insurance funds.

Naval and Military Appointments.

ROYAL NAVAL MEDICAL SERVICE.

THE following appointments are announced by the Admiralty:—Surgeon Lieutenants: A. G. Bee to the *Victory* additional, G. L. Stanley to the *Ladybird*, W. A. Jolliffe to the *Repulse*.

ARMY MEDICAL SERVICE.

ROYAL ARMY MEDICAL CORPS.

Captain P. D. Warburton retires, receiving a gratuity. Temporary Captain C. C. Chance, M.C., relinquishes the acting rank of Major.

The following temporary Captains relinquish their commissions on appointment to the I.M.S.: F. M. Kirwan, S. R. Prall, F. R. Thornton, M.C.

F. E. Feilden, late temporary Major, to be temporary Major with seniority, April 21st, 1920.

Temporary Captain O. E. French, M.C., relinquishes his commission and retains the rank of Captain.

To be temporary Lieutenants: W. E. Barnes, C. A. Ludup.

ROYAL AIR FORCE. MEDICAL BRANCH.

Captain (brevet Major) F. C. Cowtan, R.A.M.C., is granted a permanent commission as Squadron Leader (September 1st, 1919).

TERRITORIAL FORCE. ROYAL ARMY MEDICAL CORPS.

Major F. W. Kendle, T.D., resigns his commission and retains the rank of Major, with permission to wear the prescribed uniform.

To be Majors: Captains J. G. McCutcheon, G. B. Fleming, M.B.E., J. Downie, D.S.O.

Captain (acting Major) G. Potts relinquishes the acting rank of Major on ceasing to be specially employed, December 16th, 1918.

To be Captains: Major H. A. Luke (late R.A.M.C.), with precedence as from March 15th, 1918, and relinquishes the rank of Major; Captain F. J. Morria, M.C. (late R.A.M.C.), with precedence as from May 16th, 1918; Lieut. K. Fretty.

To be Lieutenants: Captain H. B. Logan (late 1st South Midland Brigade R.F.A.), with precedence as from April 21st, 1915, and relinquishes the rank of Captain; Lieutenant R. Price (late R.A.M.C.), with precedence as from June 27th, 1918; John Robinson.

TERRITORIAL FORCE RESERVE. ROYAL ARMY MEDICAL CORPS.

The announcement regarding Captain (acting Major) G. Potts, which appeared in the *London Gazette* of January 15th, 1919, is cancelled.

DEFENCE FORCE. ARMY MEDICAL SERVICE.

To be Assistant Directors of Medical Services: Temporary Colonels G. H. Edington, T.D., L. J. Blandford, C.B.E., T.D., F. G. Proudfoot.

To be Deputy Assistant Director of Medical Services: Temporary Major H. A. Leebod, T.D.

R.A.M.C.—To be temporary Majors: C. J. Martin, O.B.E., J. B. Batchelor. To be temporary Captains: L. C. Moore, W. J. M. White, D. Craig, D. G. MacLachlan.

The notification regarding temporary Major J. E. Bates in the *London Gazette*, May 5th, 1921, is cancelled.

2nd (East Anglian) Field Ambulance (D.F.)—To be temporary Captains: F. W. Poole, T. Anderson.

1st (Highland) Field Ambulance (D.F.)—To be temporary Lieutenants: G. M. Gray.

4th (Home Counties) Sanitary Section (D.F.)—To be temporary Captain: S. W. Hoyland.

3rd (Lowland) Field Ambulance (D.F.)—To be temporary Major: T. H. Richmond, O.B.E.

North Midland Divisional Sanitary Section (D.F.)—To be temporary Lieutenant: H. J. Morgan.

3rd (Northumbrian) Field Ambulance (D.F.)—To be temporary Captain: A. C. Barker.

2nd (South Midland) Field Ambulance (D.F.)—Temporary Major A. E. P. McConnell to be temporary Lieutenant-Colonel.

1st (Welsh) Field Ambulance (D.F.)—To be temporary Lieutenant-Colonel: T. Donovan, T.D. To be temporary Major: E. Bull.

3rd (Welsh) Field Ambulance (D.F.)—To be temporary Major: A. Bird. To be temporary Captain: D. Cowin.

DIARY OF SOCIETIES AND LECTURES.

MEDICO-PSYCHOLOGICAL ASSOCIATION, Maudsley Hospital, Denmark Hill, S.E.—Tues., 4.30 p.m., Sir Frederick Mott: Second Maudsley Lecture.

ROYAL COLLEGE OF PHYSICIANS OF LONDON.—Thurs., 5 p.m., Croonian Lecture by Dr. F. L. Golla: The Objective Study of Neuroses.

POST-GRADUATE COURSES AND LECTURES.

HOSPITAL FOR SICK CHILDREN, Great Ormond Street, W.C.—Thurs., 4 p.m., Mr. Pitts: Oral Sepsis.

INSTITUTE OF PATHOLOGY AND RESEARCH, St. Mary's Hospital, Paddington, W.—Thurs., 4.30 p.m., Dr. H. Head, F.R.S.: Release of Function in the Nervous System.

LONDON HOSPITAL MEDICAL COLLEGE, E.—Mon., 5 p.m., Dr. W. M. Fieldman: Ante-natal and Post-natal Child Physiology. Tues. and Fri., 5 p.m., Dr. M. Culpin: Psycho-neuroses. *Surgical Unit*: Tues. and Thurs., 4.15 p.m., Mr. Russell Howard: Diseases of the Breast.

MANCHESTER ROYAL INFIRMARY.—Tues., 4.30 p.m., Dr. W. F. Shaw: Malignant Disease of the Uterus.

QUEEN'S HOSPITAL FOR CHILDREN, Hackney Road.—Mon., 2.30 p.m., Mr. N. C. Lake: Intussusception. Tues., 4 p.m., Mr. A. H. Todd: Common Disabilities of the Lower Limbs (other than paralytic) in Children. Thurs., 4 p.m., Mr. B. W. Howell: Injuries to the Elbow. Fri., 2.30 p.m., Mr. J. Taylor: Anterior Poliomyelitis.

NATIONAL HOSPITAL FOR THE PARALYSED AND EPILEPTIC, Queen Square, W.C.—Mon., Tues., Thurs., and Fri., 2 p.m.: Out-patient Clinics. Mon., 3.30 p.m., Dr. R. Reynolds: X-Ray Demonstration of Spinal Cases. Lectures: 3.30 p.m., Tues., Mr. Armour: Surgical Treatment of Spinal Cord Tumours; Wed., Mr. Leslie Patou: Optic Atrophy; Thurs., Dr. K. Wilson: Tumours of Spinal Cord; Fri., Mr. Sargent: Surgical Treatment of Exophthalmic Goitre.

WEST LONDON POST-GRADUATE COLLEGE, Hammersmith, W.—Daily, 10 a.m., Ward Visits; 2 p.m., In- and Out-patient Clinics and Operations. Mon., 2.30 p.m., Mr. Baldwin: Demonstration of Surgical Cases. Thurs., 10.30 a.m., Dr. Simson: Gynaecological Demonstration. Lectures: 5 p.m., Mon., Dr. A. Saunders: Gastro Disorders in Adults; Tues., Mr. B. Davia: Throat, Nose, and Ear; Wed., Dr. Morton: Carbon Dioxide Snow; Thurs., Dr. A. Elsholz: Treatment and Management of Extraordinary Children; Fri., Mr. MacDonald: Retention of Urine.

British Medical Association.

OFFICES AND LIBRARY, 420, STRAND, LONDON, W.C.2.

Reference and Lending Library.

THE READING ROOM, in which books of reference, periodicals, and standard works can be consulted, is open to members from 10 a.m. to 6.30 p.m., Saturdays 10 to 2.

LENDING LIBRARY: Members are entitled to borrow books, including current medical works; they will be forwarded, if desired, on application to the Librarian, accompanied by ls. for each volume for postage and packing.

Departments.

SUBSCRIPTIONS AND ADVERTISEMENTS (Financial Secretary and Business Manager, Telegrams: Articulate, Westrand, London), MEDICAL SECRETARY (Telegrams: Mediacra, Westrand, London), EDITOR, *British Medical Journal* (Telegrams: Attiology, Westrand, London).

Telephone number for all Departments: Gerrard 2650 (3 lines).

SCOTTISH MEDICAL SECRETARY: 6, Rutland Square, Edinburgh. (Telegrams: Associate, Edinburgh. Tel.: 4361 Central.)

IRISH MEDICAL SECRETARY: 16, South Frederick Street, Dublin. (Telegrams: Reclillus, Dublin. Tel.: 4737 Dublin.)

Diary of the Association.

JUNE.

- 3 Fri. London: Medico-Sociological Committee, 2.30 p.m.
7 Tues. London: Naval and Military Committee, 2.30 p.m.
8 Wed. North Lincolnshire Division, Grimsby: Address by Medical Secretary.
Thur. London: Organization Committee.
Kent Branch Annual Meeting, London County Council Mental Hospital, Bexley, near Dartford, 2.30 p.m.
Bedford Division Annual Meeting, Bridge Hotel, Bedford, 3.30 p.m.; Luncheon, 1.15 p.m.; Executive Committee, 3.15 p.m.
10 Fri. London: Medico-Sociological Committee, 2 p.m.
14 Tues. Isle of Ely Division: Address by the Medical Secretary.
15 Wed. South-Western Branch Annual Meeting, White Hart Hotel, St. Austell, 3.15 p.m.; Luncheon, 1 p.m. to 2.15 p.m.; Annual Dinner, 7.45 p.m.
16 Thurs. Central Division, Annual Meeting, 18, Bennett's Hill, 3.45 p.m.
22 Wed. London: Council.
24 Fri. Metropolitan Counties Branch Annual Meeting, 429, Strand, W.C.2, 4 p.m.
29 Wed. London: Propaganda Subcommittee, 2.15 p.m. Oxford and Reading Branch Annual Meeting, Town Hall, Maidenhead.
30 Thur. Worcestershire and Herefordshire Branch: Annual Meeting, The Infirmary, Worcester, 3 p.m.

JULY.

- 8 Fri. Surrey Branch Annual Meeting, Guildford.

APPOINTMENTS.

COATES, Vincent M., M.C., M.A., M.D., B.Ch.Cantab., M.R.C.S., L.R.C.P., Honorary Assistant Physician to the Royal United Hospital, Bath.

FITZGERALD, Edward John, M.B., Ch.B.Glasg., L.M.Rotunda, Surgeon to the Moil Cottage Hospital.

HIRSCH, Charles T. W., M.R.C.S., L.R.C.P., appointed Anaesthetist to the Royal Ear Hospital (Ear, Nose, and Throat Department of University College Hospital).

HUTTON, Eustace, M.R.C.S., L.R.C.P., Senior Assistant Medical Officer, North Wales County Asylum, Denbigh.

ST. THOMAS'S HOSPITAL.—The following gentlemen have been selected as house officers.—*Casualty Officers and Resident Anaesthetists*: G. D. C. Tracy, B.A.Cantab., M.R.C.S., L.R.C.P.; S. H. G. Humphrey, B.A.Cantab., M.R.C.S., L.R.C.P. *Resident Orthopaedic House-Surgeon*: E. P. Brockman, B.A., M.B., B.Ch. Cantab., M.R.C.S., L.R.C.P. *Obstetric House-Physicians*: (Senior) E. S. Orme, B.A.Cantab., M.R.C.S., L.R.C.P. (Junior) G. Cranston, B.A. Oxon., M.R.C.S., L.R.C.P. *Senior Ophthalmic House-Surgeon*: E. A. Sparks, M.R.C.S., L.R.C.P. *Clinical Assistants*: (Skin) J. A. P. Shaw, B.A. Cantab., M.R.C.S., L.R.C.P., H. L. Slaughter, M.R.C.S., L.R.C.P.; (Ear) F. G. Wood, M.A., B.Ch. Cantab., M.R.C.S., L.R.C.P.; (Children's Medical) K. H. Tallerman, M.C., B.A. Cantab., M.R.C.S., L.R.C.P.; O. L. C. Burns, M.R.C.S., L.R.C.P.; (Tuberculosis Department) C. L. C. Burns, M.R.C.S., L.R.C.P.; F. Moor, M.C., M.A., M.B., B.Ch. Cantab., M.R.C.S., L.R.C.P.; (X-ray Department) R. C. Cooke, D.S.O., M.C., M.R.C.S., L.R.C.P.; (Mental) J. Rickman, M.A., M.B., B.Ch. Cantab.; (Electro-Therapeutic Department) R. C. Cooke, D.S.O., M.C., M.B.C.S., L.R.C.P. Several other gentlemen have also received extensions of their appointments.

BIRTHS, MARRIAGES, AND DEATHS.

The charge for inserting announcements of Births, Marriages, and Deaths is 9s., which sum should be forwarded with the notice not later than the first post on Tuesday morning, in order to ensure insertion in the current issue.

MARRIAGE.

GILMORE—BROOKS.—February 19th, 1921, at the Baptist Church, San Salvador, Portuguese Congo, by the Rev. R. H. C. Graham, Haldane Carson, L.R.C.P. and S.I., elder son of the Rev. J. Dinan Gilmore of Dublin, to Mary O'Kall, second daughter of the late William Brooks of Stowmarket, Suffolk.

DEATHS.

HARCOURT.—On May 13th, at his residence, "Stoneleigh," 4, Oakfield, Liverpool, Richard Eugene Harcourt, M.D., F.R.C.S. Eng., aged 63 years.

MORTON.—May 28th, at Terretet, Switzerland, Charles James Morton, M.D., Edin., late of Walthamstow and Welbeck Street.



Royal Victoria Infirmary, Newcastle-on-Tyne.

British Medical Association.

EIGHTY-NINTH ANNUAL MEETING, NEWCASTLE-UPON-TYNE, JULY, 1921.

Patron: HIS MAJESTY THE KING.

President: The Right Hon. Sir T. CLIFFORD ALLBUTT, B.C., K.C.B., F.R.S., Regius Professor of Physic, University of Cambridge.

President-Elect: DAVID DRUMMOND, C.B.E., M.A., M.D., D.C.L., Vice-Chancellor and Professor of the Principles and Practice of Medicine, University of Durham.

Chairman of Representative Meetings: T. W. H. GARSTANG, M.A., M.R.C.S., D.P.H.

Chairman of Council: R. A. BOLAM, M.D., M.R.C.P.

Treasurer: G. E. HASLIP, M.D.

PROGRAMME.

The President, Professor DAVID DRUMMOND, will give an Address on Tuesday, July 19th, at 8 p.m.

The ANNUAL REPRESENTATIVE MEETING will begin on Friday, July 15th, at 10 a.m., and be continued on the following days.

The REPRESENTATIVES' DINNER will be held on Friday, July 15th, at 7.30 p.m.

The statutory ANNUAL GENERAL MEETING will be held on July 19th, at 2 p.m., and the Adjourned General Meeting at 8 p.m.

The Annual Dinner of the Association will take place on Thursday, July 21st, at 7.30 p.m.

Religious services will be held on Tuesday, July 19th, at 5 p.m.

The Conference of Secretaries will be held at 2 p.m. on Wednesday, July 20th, and the Secretaries' Dinner will take place in the evening at 6.30.

A Special Address on "Industrial Hygiene; its Rise, Progress and Opportunities," will be given by Sir Thomas Oliver, LL.D., M.D., F.R.C.P., on Wednesday, July 20th, at 8 p.m.

The Popular Lecture, on "Evolutionary Wounds," will be delivered by Professor Arthur Keith, F.R.S., on Friday, July 22nd, at 7.30 p.m.

THE SCIENTIFIC SECTIONS.

The Sections will meet from 10 a.m. to 1 p.m. Laboratory and Clinical Demonstrations will be given on Wednesday, July 20th, Thursday, July 21st, and Friday, July 22nd, between 3 p.m. and 4.30 p.m.

The following Sections meet on three days—Wednesday, Thursday, and Friday, July 20, 21, and 22.

MEDICINE.

President: Professor THOMAS BEATTIE, M.D., F.R.C.P.

Vice-Presidents: The Right Hon. LORD DAWSON of PENN, G.C.V.O., M.D., F.R.C.P.; Professor A. J. HALL, M.D., F.R.C.P.; G. S. HAYNES, M.D., M.R.C.P.; J. WILKIE SMITH, M.D.

Honorary Secretaries: C. E. LARIN, M.D., F.R.C.P., (105, Harley Street, London, W.1); W. T. RITCHIE, O.B.E., M.D., F.R.C.P.Ed. (14, Rothesay Place, Edinburgh); Professor W. E. HUME, C.M.G., M.D., F.R.C.P. (4, Ellison Place, Newcastle-on-Tyne).

The following provisional programme has been arranged:—

July 20th (10 a.m.)—Discussion: Visceral Syphilis, especially of the Central Nervous System and Cardio-Vascular System. To be introduced by the Right Hon. Sir CLIFFORD ALLBUTT, K.C.B., F.R.S., followed by Dr. Gordon Holmes, Professor Reynolds, Dr. John Cowan, Dr. A. G. Gibson, Dr. John Eason and Dr. Ivy McKenzie.

July 21st (10 a.m.)—Discussion: Asthma and Allied Disorders. To be opened by Sir HUMPHRY REYNOLDS, K.C.B., followed by Dr. John Freeman, Dr. A. F. Hill, Mr. Frank Coke, Dr. Mackenzie Wallis and Dr. Charles McNeil.

July 22nd 10-11.30 a.m.—Discussion: Encephalitis Lethargica. To be opened by Dr. EDWIN BRADWELL, followed by Dr. Wilfred Harris, Professor A. J. Hill, Dr. C. H. Meland, 11.30 a.m.—1 p.m.—Discussion: Renal Efficiency Tests. To be opened by Professor H. McLEAN, followed by Professor Boyd, Dr. R. L. Mackenzie Wallis, and Dr. D. Wells Patterson.

In the afternoons of Wednesday, Thursday and Friday, from 3 to 4.30, cases will be demonstrated by the honorary medical staff in the medical wards of the Royal Victoria Infirmary. Short papers and demonstrations will be arranged during the same hours.

Anyone wishing to take part in the above discussions, or give demonstrations, is asked to communicate with Dr. W. E. Hume, Honorary Secretary, Section of Medicine, 4, Ellison Place, Newcastle-on-Tyne, in order that he may forward a copy of the opener's remarks when available.

SURGERY.

President: Professor J. RUTHERFORD MORISON, D.C.L., LL.D., F.R.C.S.

Vice-Presidents: Professor H. BRUNTON ANGUS, F.R.C.S.; ARTHUR COOKE, F.R.C.S.; W. J. GILLER, F.R.C.S.I.; A. M. MARTIN, M.B.

Honorary Secretaries: W. GIRLING BAILL, F.R.C.S. (77, Wimpole Street, London, W.1); J. M. RENDON, F.R.C.S. (16, Sandyford Place, Glasgow, W.); G. GRLEY TURNER, M.S., F.R.C.S., F.A.C.S. (The Hawthorns, Osborne Road, Newcastle-on-Tyne).

The following provisional programme has been arranged:

July 20th (Morning Session).—Discussion: Acute Pleural Empyema. To be opened by Mr. HENRY WADDELL, C.M.G., D.S.O., M.D., F.R.C.S.Edin. (Edinburgh).

In the afternoon, at 3 o'clock, demonstrations will be given by Professor RUTHERFORD MORISON, at the War Pensions Hospital, of cases and specimens illustrating (1) Bipp, (2) Bone Cavities, (3) Bone Grafts. Cases will also be shown by other members of the staff.

July 21st (Morning Session).—Discussion: Compound Fracture of the Thigh and Leg.

In the afternoon, at 3 o'clock, demonstrations will be given at the Royal Victoria Infirmary of cases and specimens illustrating Compound Fracture of the Thigh and Leg.

July 22nd (Morning Session).—Discussion: The Diagnosis and Treatment of Injuries of the Intestines. To be opened by Mr. GORDON TAYLOR, O.B.E., M.S. (London).

In the afternoon, at 3 o'clock, demonstrations will be given by Mr. G. GREY TURNER at the Royal Victoria Infirmary of six cases of implantation of the ureter into the bowel.

Operations will be arranged by the staff of the Royal Victoria Infirmary for each afternoon at 2 o'clock.

One or two short papers will also be read on each day after the discussion.

Anyone wishing to take part in the discussions or demonstrations is invited to communicate with the Secretaries, and those wishing to read short papers are asked to send a summary, to be brought before the officers of the Section. There will also be an exhibition of specimens illustrating the subjects for discussion, and members are asked to advise the Secretaries of any specimens they propose to exhibit.

PATHOLOGY AND BACTERIOLOGY.

President: Professor STUART McDONALD, M.D., F.R.C.P. Ed.

Vice-Presidents: J. F. GASKELL, M.D., F.R.C.P.; JAMES A. MURRAY, M.D.; Professor MATTHEW J. STEWART, M.B., M.R.C.P.

Honorary Secretaries: R. R. ELWORTHY, O.B.E., M.D., M.R.C.P. (West London Hospital, Hammersmith, London, W.6); A. F. BERNARD SHAW, M.D., M.R.C.P.I. (Pathological Department, College of Medicine, Newcastle-on-Tyne).

Pathological Museum.

The Pathological Museum Committee proposes to arrange the material under the following heads: (1) Exhibits bearing on discussions and papers to the various Sections; (2) specimens and illustrations relating to any recent research work; (3) instruments relating to clinical diagnosis and pathological investigation; (4) individual specimens of special interest or a series illustrating some special subject. It is proposed to gather together a series of exhibits illustrating the pathology of individual cases. Such exhibits will include a brief clinical history of the case and mounted specimens of the different organs and tissues illustrating the pathological changes and the correlation of the lesions. Other interesting specimens will be welcomed. The Honorary Secretary of the Pathological Museum Committee is Dr. A. F. Bernard Shaw, Pathological Department, College of Medicine, Newcastle-upon-Tyne. The museum will occupy a central position in the same building as that in which the sectional work is carried on. Every care will be taken of specimens, and the contents of the museum will be insured. It is hoped to make arrangements for exhibitors to demonstrate their specimens.

PREVENTIVE MEDICINE WITH INDUSTRIAL DISEASES

President: Sir THOMAS OLIVER, LL.D., M.D., F.R.C.P.

Vice-Presidents: Sir JOSIAH COURT, M.R.C.S.; T. EUSTACE HILL, O.B.E., M.B.; I. G. MODLIN, O.B.E., M.D.

Honorary Secretaries: C. M. WILSON, M.C., M.D. (64, South Anley Street, Grosvenor Square, W.1); W. H. DICKINSON, O.B.E., M.B., D.P.H. (91, Newbridge Street, Newcastle-on-Tyne).

The following provisional programme has been arranged:

July 20th.—Discussion: The Effect of Health Legislation on the Health of the People.

July 21st.—Discussion: The Importance of Industrial Medicine to the Community. To be introduced by Professor COLLIS (Carliff), followed by Dr. T. M. LEGGE.

July 22nd.—Proposed joint meeting with the Section of Medical Sociology.

ORTHOPÆDICS AND DISEASES IN CHILDREN.

President: A. II. TUBBY, C.B., C.M.G., M.S., F.R.C.S.

Vice-Presidents: R. C. ELSLIE, O.B.E., M.S., F.R.C.S.; H. MORLEY FLETCHER, M.D., F.R.C.P.; LACHLAN G. FRASER, M.D.; Sir HENRY M. W. GRAY, K.B.E., C.B., C.M.G., F.R.C.S.; A. E. MORISON, F.R.C.S. Edin. (Director of Demonstrations).

Honorary Secretaries: C. MAX PAGE, D.S.O., F.R.C.S. (134, Harley Street, London, W.1); FRANK HAWTHORN, D.S.O., M.D. (10, Ellison Place, Newcastle-on-Tyne); H. R. SOUPER, M.D. (Ministry of Pensions Hospital, Castle Leazes, Newcastle-on-Tyne).

The following preliminary programme has been arranged:

July 20th (10 a.m.).—*Chairman:* Mr. A. II. Tubby. Discussion: The Early Diagnosis and Treatment of Anterior Poliomyelitis.

July 21st (10 a.m.).—*Chairman:* Dr. H. Morley Fletcher. Discussion: Blood Diseases in Children.

July 22nd (10 a.m.).—*Chairman:* Sir Henry M. W. Gray. Discussion: Tuberculosis of Bone; General Principles of Treatment.

The following Sections meet on two days—Wednesday and Thursday, July 20 and 21.

NEUROLOGY AND PSYCHIATRY.

President: Professor A. W. MACKINTOSH, M.D., F.R.C.P. Ed.

Vice-Presidents: A. HELEN A. BOYLE, M.D.; E. FARQUHAR BUZZARD, M.D., F.R.C.P.; HARRY CAMPBELL, M.D., F.R.C.P.; HORSLEY DRUMMOND, M.D.

Honorary Secretaries: ANTHONY FEILING, M.D., F.R.C.P. (41, Devonshire Street, London, W.); GEORGE HALL, C.M.G., M.D., M.R.C.P. (1, Eslington Road, Jesmond Road, Newcastle-on-Tyne).

The following provisional programme has been arranged:

July 20th (10 a.m.).—Discussion: The Diagnosis and Treatment of Borderland Cases. To be opened by Professor G. M. ROBERTSON (Edinburgh) and Dr. JAMES COLLIER (London).

July 21st (10 a.m.).—Papers: (1) Dr. HARRY CAMPBELL (London), The Nervous Diathesis and the Blood. (2) Dr. G. RIDDOCH (London), Some Points in the Management and Treatment of Paraplegia. (3) Dr. F. M. R. WALSH (London), Observations on the Mechanism of Symptom Production in Disease and Injury of the Nervous System. (4) Dr. A. E. A. CARVER (Birmingham), Epilepsy from the Psychological Standpoint. (5) Dr. JUNSON BURY (Manchester), Remarks on the Pathology and Symptoms of Paralysis Agitans. (6) Dr. DOUGLAS ADAMS (Glasgow), The Early Diagnosis and Treatment of Disseminated Sclerosis.

OPHTHALMOLOGY.

President: Professor J. D. WARDALE, M.B., B.S.

Vice-Presidents: H. P. BENNETT, M.B.; Lieut.-Colonel R. H. ELLIOT, M.D., F.R.C.S., I.M.S. (ret.); HARRY M. TRAQUAIR, M.D., F.R.C.S. Ed.

Honorary Secretaries: N. B. B. FLEMING, M.B., Ch.B. (9, Harley Street, London, W.1); STANLEY ROBSON, M.S., F.R.C.S. Ed. (Milton House, Rowlands Gill, co. Durham).

The following provisional programme has been arranged:

July 20th (10 a.m.).—Discussion: The Causes and Prevention of Blindness. To be opened by Mr. BISHOP HARMAN, F.R.C.S. (London).

July 21st (10 a.m.).—Discussion: The Treatment of Corneal Ulcers. To be opened by Mr. J. V. PATERSON, F.R.C.S. Edin. (Edinburgh).

OTO-RHINO-LARYNGOLOGY.

President: G. WILLIAM HILL, M.D., B.Sc.

Vice-Presidents: R. GORDON BELL, M.D., F.R.C.S. Edin.; JAMES DON, M.D.; DAN MCKENZIE, M.D., F.R.C.S. Edin.

Honorary Secretaries: LIONEL COLLEGE, M.B., F.R.C.S. (22, Queen Anne Street, London, W.1); W. FRANK WILSON, M.B., B.S. (97, Jesmond Road, Newcastle-upon-Tyne).

The following provisional programme has been arranged:

July 20th (10 a.m.).—Discussion: Problems in connexion with the Early Diagnosis and Treatment of Meningitis occurring in Aural Cases. To be opened by Sir CHARLES BALLANCE, K.C.M.G., C.B.

July 21st (10 a.m.).—Discussion: The Various Problems presented by Haemorrhage occurring in connexion with Operations on the Tonsils.

PHYSIOLOGY, PHARMACOLOGY, THERAPEUTICS, AND DIETETICS.

President: H. H. DALE, C.B.E., M.D., F.R.S.

Vice-Presidents: Professor A. V. HILL, M.A., D.Sc., F.R.S.; Professor JOHN C. MEAKINS, M.D.; Professor J. A. MENZIES, M.D.; ALFRED PARKIN, M.D., M.R.C.P.

Honorary Secretaries: O. INCHLEY, M.A., M.D. (Balraham, Cambridge); Miss MILDRED ATKINSON, B.Sc. (College of Medicine, Newcastle-on-Tyne).

The following provisional programme has been arranged: Papers from 10 a.m. to 1 p.m., and demonstrations from 3 p.m. to 4.30 p.m.

July 20th.—Paper by Professor A. V. HILL, D.Sc., F.R.S.: The Use of the Hot Wire for Investigating (a) the Time Relations of the Pulse; (b) the Characteristics of Voluntary Contractions in Man. Paper and demonstration by Professor J. A. MENZIES, Miss MILDRED ATKINSON, and G. A. CLARK: The Passage of Sulphate through the Cells of the Tubules of the Kidney of the Frog. Paper by Professor H. H. DALE, F.R.S.: Anaphylatoxin.

July 21st.—Paper, with lantern demonstration, by Dr. H. MUIR EVANS: The Poison Organs and Venoms of Venomous Fish. Paper by Dr. C. H. BROWNING: Recent work on Chemotherapy. Paper by Dr. G. ARBOUR STEPHENS: Acid Feeders, and the Deleterious Effects of too much Acid in the Food. Paper by Dr. SIM WALLACE: Physiology of Oral Hygiene.

July 22nd.—Joint discussion with the Section of Medicine on Tests for Renal Efficiency.

VENEREAL DISEASES.

President: Colonel L. W. HARRISON, D.S.O., R.A.M.C.

Vice-Presidents: JAMES CHARLES BUCKLEY, M.D.; CHARLES GIBBS, F.R.C.S.; MARY RAW, M.B.

Honorary Secretaries: KENNETH M. WALKER, O.B.E., F.R.C.S. (86, Harley Street, London, W.); JAMES HUDSON, M.D. (42, Crossley Terrace, Newcastle-on-Tyne).

The following provisional programme has been arranged:

July 20th (10 a.m.).—Treatment of Syphilis in Man, by Dr. R. MacKenna. Syphilis in Women and Children, by Professor Walter Swayue.

July 21st (10 a.m.).—Treatment of Gonorrhoea in Men, by Dr. David Lees. The Standard of Cure in Gonorrhoea, by Dr. Townley Clarkson.

In the afternoon of Wednesday (July 20th) a demonstration will be held of Methods of Diagnosis and Treatment in Venereal Diseases, Dark-ground Illumination Work, Models of Venereal Disease Clinics, etc.

The following Section meets on two days—Thursday and Friday, July 21 and 22.

OBSTETRICS AND GYNAECOLOGY.

President: Professor R. P. RANKEN LYLE, M.D. Vice-Presidents: Lady BARRETT, M.D.; W. R. GROVE, M.D.; WILLIAM ROBINSON, F.R.C.S. Honorary Secretaries: GORDON LEY, F.R.C.S. (5, Wimpole Street, London, W.1); MABEL R. CAMPBELL, M.A., M.B. (49, Wingrove Road, Newcastle-on-Tyne); E. FARQUHAR MURRAY, M.D., F.R.C.S. (52, Jesmond Road, Newcastle-on-Tyne).

The following provisional programme has been arranged: July 21st (10 a.m.).—Discussion: The Role of Caesarean Section in Midwifery. To be opened by Dr. EARDLEY L. HOLLAND (London) and Dr. J. M. MUNRO KERR (Glasgow). Paper: The Treatment of Advanced Malignant Disease of the Cervix, by Dr. ARTHUR BURROWS (Manchester), to be followed by a discussion. July 22nd (10 a.m.).—Discussion: The Neurasthenic Element in Midwifery and Gynaecology. To be opened by Dr. ARCHIBALD DONALD (Manchester) and Dr. FARQUHAR BUZZARD (London). Papers to be followed by discussion: (1) Curettage, (a) Diagnostic, (b) Treatment of Uterine Haemorrhage, by Dr. H. BECKWITH WHITEHOUSE (Birmingham). (2) The Position of the Medical Practitioner called in to attend a case of Procured Abortion, by Dr. JOHN CAMPBELL (Belfast).

The following Sections meet on one day as indicated

Wednesday, July 20th.

AMBULANCE AND RED CROSS.

President: Sir JAMES CANTLIE, K.B.E., F.R.C.S. Vice-Presidents: ROBERT ANDERSON, M.D.; Sir G. T. BEATSON, K.C.B., K.B.E., M.D.; Major-General Sir G. J. H. EVATT, K.C.B., M.D.; Rev. C. F. TOWNLEY, M.A. Honorary Secretaries: R. M. VICK, O.B.E., F.R.C.S. (The Warden's House, St. Bartholomew's Hospital, E.C.1); H. L. RUTTER, M.B.E., F.R.C.S. (31, West Parade, Newcastle-on-Tyne).

PROCTOLOGY.

President: J. P. LOCKHART-MUMMERY, F.R.C.S. Vice-Presidents: HENRY B. DENSHAM, M.B.; W. ERNEST MILES, F.R.C.S.; D. P. D. WILKIE, O.B.E., F.R.C.S. Honorary Secretaries: CRECH W. ROWNTREE, F.R.C.S. (9, Upper Brook Street, London, W.1); HAMILTON DRUMMOND, F.R.C.S. (Edin. (6, Saville Place, Newcastle-on-Tyne).

July 20th.—Discussion: The Surgical Treatment of Internal Haemorrhoids. To be opened by Sir CHARLES GORDON-WATSON, K.B.E., and Mr. D. P. WILKIE, F.R.C.S. (Edinburgh).

Thursday, July 21st.

DERMATOLOGY.

President: JOHN FARQUHAR CHRISTIE, M.A., M.B. Vice-Presidents: ERNEST DOBE, M.D., F.R.C.P.; ARTHUR D. HEATH, M.D., M.R.C.P.; D. WELLS PATTERSON, O.B.E., M.D., M.R.C.P. Honorary Secretaries: WILLIAM JENKINS OLIVER, M.A., M.B. (58, Queen Anne Street, London, W.1); SYDNEY THOMPSON, M.B., B.S. (19, Windsor Terrace, Newcastle-on-Tyne).

NOTIFICATION OF ATTENDANCE.

To be filled up and returned to the HONORARY LOCAL GENERAL SECRETARY, Mr. R. J. Hillan, M.I.O. O.B.E., F.R.C.S., 6, Kensington Terrace, Newcastle-on-Tyne.

All Members of the Association who intend to take part in the Annual Meeting are earnestly requested to fill up and post the form printed below, as soon as possible. Early intimation will greatly facilitate the arrangements for official entertainments, as well as for private hospitality.

The Room for Registration at the College of Medicine, Northumberland Road, will be open from 2.30 p.m. to 6 p.m. on Monday, July 18th, and from 9 a.m. to 6 p.m. on the other days of the meeting. It is hoped that as many as possible of those who are attending the meeting will take the opportunity to register on Monday afternoon.

The Annual Exhibition of SURGICAL INSTRUMENTS, DRUGS, FOODS, etc., arranged in connexion with the Meeting, will be held in the St. George's Drill Hall, St. Mary's Place, on Tuesday, Wednesday, Thursday, and Friday, July 19th to 22nd, from 9.0 a.m. to 6.0 p.m. daily.

Please write distinctly.

Name _____ Address _____

- (1) Is it your intention to attend the Annual Meeting at Newcastle?
(2) Will you be accompanied by a lady?
(3) Are you making your own arrangements for lodgings?
(4) Do you wish for private hospitality?
(5) Date of arrival.
(6) Date of departure.

The following provisional programme has been arranged:

July 21st (10 a.m.).—Discussions: (1) Cutaneous Sensitization and Focal Sepsis in the Etiology of certain Skin Affections. To be opened by H. W. BARBER, M.B., M.R.C.P. (2) The Association of Skin Tuberculosis with Visceral and other Tuberculous Manifestations. To be opened by GEORGE H. LANCASHIRE, M.D. (3) Dermatological Cases attending the Pensions Boards. To be opened by HENRY MACCORMAC, C.B.E., M.D., F.R.C.P. (with the permission of the Ministry of Pensions).

Friday, July 22nd.

MEDICAL SOCIOLOGY.

President: Sir JENNER VERRALL, LL.D., M.R.C.S.
Vice-Presidents: CHARLES BUTTAR, M.A., M.D.; A. C. FARQUHARSON, M.D., M.P.; E. ROWLAND FOTHERGILL, M.B., B.S.
Honorary Secretaries: J. F. WALKER, M.B. (Rocklands, Clifton Terrace, Southend-on-Sea); MABEL G. BRODIE, M.B. (Maternity and Child Welfare Offices, 42, Old Elvet, Durham).

The following provisional programme has been arranged:
July 22nd (10 a.m.).—Discussion: The Relation of the Medical Profession to Local Authorities in respect to Rate-provided Hospitals and Clinics.

RADIOLOGY AND ELECTRO-THERAPEUTICS.

President: ROBERT KNOX, M.D.
Vice-Presidents: W. HOPE FOWLER, F.R.C.S.Edin.; ROBERT EDWARD HOWELL, M.B., C.M.
Honorary Secretaries: JAMES METCALFE, M.D. (123, Harley Street, London, W.1); THOMAS LOWE BUNTING, M.D. (6, Portland Terrace, Newcastle-on-Tyne).

The following provisional programme has been arranged:
July 22nd (10 a.m.).—Discussion: On the Changes induced in Blood Constituents by Radiations: (a) Experimental evidence, Professor SIDNEY RUSS and Dr. ARCHIBALD LEITCH; (b) Clinical observations, Dr. MOTTRAM, Dr. GAMLEN, Dr. J. B. WATERS, Dr. METCALFE, Dr. HOPE FOWLER and others. On Morbid Conditions of the Blood: (1) The Anaemias, (2) Leukaemia, (3) Banti's disease, etc. Opening paper by Professor G. L. GULLAND, C.M.G. (Edinburgh). Discussion on Surgical Diathermy, to be opened by Dr. CUMBERBATCH, followed by Dr. HOWARD HUMPHRIS, Dr. SABERTON and others.

Exhibition of radiograms, etc., in the Pathological Museum.
A visit will be paid to the x-ray and electro-therapeutic departments of the Royal Victoria Infirmary, Newcastle-upon-Tyne.

UROLOGY.

President: J. W. THOMSON WALKER, O.B.E., F.R.C.S.
Vice-Presidents: P. J. CAMMIDGE, M.D.; JOHN CLAY, C.B.E., F.R.C.S.; H. C. PEARSON, F.R.C.S.Ed.
Honorary Secretaries: SYDNEY G. MACDONALD, F.R.C.S. (61, Queen Anne Street, London, W.1); W. S. DIKIE, O.B.E., F.R.C.S. (Ardencapel, Southfield Road, Middlesbrough).

The following provisional programme has been arranged:
July 22nd (10 a.m.).—Discussion: The Diagnosis and Treatment of Cystitis. To be opened by J. F. DOBSON, M.S., F.R.C.S. (Surgical). Papers: Experimental Evidence bearing on the Source of the Amylolytic Ferment in the Urine, by P. J. CAMMIDGE, M.D.; Open Prostatectomy, by J. W. THOMSON WALKER, M.B., F.R.C.S.; Treatment of Bladder Growths, by SYDNEY G. MACDONALD, M.B., F.R.C.S.

The Honorary Local General Secretary of the meeting is R. J. WILLAN, M.V.O., O.B.E., F.R.C.S., 6, Kensington Terrace, Newcastle-on-Tyne.

APPLICATIONS FOR ACCOMMODATION.

MEMBERS proposing to attend the Annual Meeting should bear in mind that they may not be able to obtain adequate accommodation, even at some distance, unless it is reserved well beforehand. Up to the present the number of applications has been small, and even the reserved hotel accommodation has not yet been booked up. As the hotels will be unable to reserve this accommodation much longer it is essential that applications should be sent in at once.

Lists of hotels, etc., were printed in the SUPPLEMENT of May 7th, and revised particulars about accommodation at Newcastle in the SUPPLEMENT of May 21st. The Honorary Secretary of the Hotels and Lodgings Committee is Dr. E. F. MURRAY, 52, Jesmond Road, Newcastle-upon-Tyne, who will gladly give any information about accommodation to members who apply to him.

Stamp.

The Hon. Local GENERAL SECRETARY,
British Medical Association,

6, Kensington Terrace,
Newcastle-on-Tyne.

If not already a Member, you are invited to fill up this Form and forward it to:—

THE MEDICAL SECRETARY,

BRITISH MEDICAL ASSOCIATION,

429, STRAND, W.C. 2

BRITISH MEDICAL ASSOCIATION.

FOUNDED 1832.

Patron: HIS MAJESTY THE KING.

THE BRITISH MEDICAL ASSOCIATION is established for the promotion of the Medical and allied Sciences and the maintenance of the honour and interests of the Medical Profession. It has Divisions and Branches throughout the British Empire. There are 43 Branches, with 216 Divisions, in the United Kingdom, and 47 Branches with 64 Divisions, in the British Empire Overseas.

Any Medical Practitioner registered in the United Kingdom under the Medical Acts, any Medical Practitioner who does not reside within the area of any Branch of the Association and who, though not so registered, is possessed of any of the qualifications described in Schedule (A) of the Medical Act, 1858, and any Medical Practitioner residing within the area of any Branch of the Association situate in any part of the British Empire other than the United Kingdom who is so registered or possesses such medical qualification as shall (subject to the By-laws) be prescribed by the Rules of the said Branch, is eligible as a Member of the Association. Members of the Association are, *ipso facto*, Members of the Division and Branch in the areas of which they reside.

The liability of Members is limited.

The annual subscription, which is due in advance on January 1st in each year, and entitles the Member to all the ordinary privileges of Membership of the Association, including Membership of the Division and Branch in which he or she resides, and the weekly supply of the *British Medical Journal* post free, is as follows:—

Member resident in United Kingdom	3 Guineas.
<small>(In the case of newly qualified practitioners elected within two years of registration, 1½ guineas yearly, up to end of 4th year after registration).</small>	
Member resident in a Branch outside United Kingdom	2 Guineas or more,
<small>according to the Rules of the various Branches.</small>	
Member resident outside United Kingdom where no Branch is organised	2 Guineas

In the case of a Member elected after June 30th, in any year, the subscription for that year is one-half the current annual subscription.

If you desire to become a Member of the Association, please fill in and post this form to the Association, 429, Strand, London, W.C. 2.* Election is ordinarily by the Council of the Branch in the area of which the Candidate resides, but in the case of Candidates resident in any area outside the United Kingdom in which no Branch is organised, is by the Council of the Association. In the case of most Branches, no signature, other than that of the Candidate, is required. For election by the Council (as above), 3 approving signatures are ordinarily required. Under no circumstances are approving signatures necessary in the case of Officers of the Royal Navy, Royal Air Force, Army, Indian Medical Service or Colonial Medical Services, on the Active List.

APPLICATION FOR ELECTION.

TO THE BRITISH MEDICAL ASSOCIATION,
429, STRAND, LONDON, W.C. 2.

(Full Christian and surnames. Please write distinctly.) I, _____ a Registered Medical Practitioner, am desirous of being, and hereby apply to be elected a Member of the BRITISH MEDICAL ASSOCIATION, and I agree, if elected, to pay the subscription and to abide by the Articles and By-laws of the Association for the time being in force, and the Rules of the Division and Branch to which I may at any time belong.

Signature _____

Titles _____

Home Address _____

Date _____, 1921 .

Additional Forms of Application for Membership, and all particulars, may be had on application to the BRITISH MEDICAL ASSOCIATION, 429, Strand, London, W.C. 2.

* Applicants for Membership resident in the areas of the Oversea Branches should send their applications and remittances to the Honorary Secretary of the Branch, if his or her address is known to them, failing which the application and remittance should be sent to the Head Office, 429, Strand, London, W.C. 2.

Fold Here.

Fold Here.

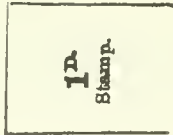

THE MEDICAL SECRETARY,
BRITISH MEDICAL ASSOCIATION,
429, STRAND,
LONDON, W.C.2.

Fold Here.

..... Please Detach Here,

SUPPLEMENT

TO THE

BRITISH MEDICAL JOURNAL.

LONDON: SATURDAY, JUNE 11TH, 1921.

CONTENTS.

BRITISH MEDICAL ASSOCIATION.			PAGE	CORRESPONDENCE:			PAGE
CURRENT NOTES:				Dr. Macdonald's Mission to South Africa 226			
THE MACDONALD PRESENTATION	221	HOSPITAL TREATMENT OF INSURED PERSONS 226			
REPORTS OF GOVERNMENT COMMITTEES	221	GENERAL MEDICAL COUNCIL:			
THE NEW POSTAL RATES	221	RESULTS OF QUALIFYING EXAMINATIONS 225			
FEE FOR EXAMINATION OF CIVIL SERVICE CANDIDATES	221	INSPECTION OF PUBLIC HEALTH EXAMINATIONS 225			
THE NEW ZEALAND BRANCH	221	DENTAL EDUCATION AND EXAMINATION 225			
COUNCIL ELECTION	222	ELECTIONS TO COMMITTEES 225			
MEETINGS OF BRANCHES AND DIVISIONS	222	INSURANCE:			
MEETINGS TO BE HELD...	2-3	POSITION OF INSURANCE ACTS COMMITTEE... 227			
ASSOCIATION NOTICES	224	NAVAL AND MILITARY APPOINTMENTS... 227			
NOTICES OF MOTION BY DIVISIONS FOR THE ANNUAL	224	DIARY OF SOCIETIES AND LECTURES 228			
REPRESENTATIVE MEETING	224	APPOINTMENTS... 228			
ASSOCIATION INTELLIGENCE	228	BIRTHS, MARRIAGES, AND DEATHS 228			

British Medical Association.

CURRENT NOTES.

The Macdonald Presentation.

THE Macdonald Presentation Fund will be closed at the end of the present month. The intention is to make the presentation to Dr. J. A. Macdonald during the forthcoming Annual Meeting of the Association at Newcastle-on-Tyne. Subscriptions of any amount not exceeding five guineas, and made payable to "The Macdonald Presentation," should be sent to the Medical Secretary, 429, Strand, W.C.2., not later than June 30th.

Reports of Government Committees.

No meeting of the Hospitals Committee has been held during this quarter, but it is expected that it will be called together in the immediate future to consider the report issued late this week of the committee presided over by Viscount Cave, which has been inquiring into the financial position of voluntary hospitals throughout the country. Another committee whose report is expected shortly is that presided over by the Earl of Athlone, which has been inquiring into post-graduate medical education in London. When this report appears it will be examined by the Science Committee, representatives of which gave evidence on behalf of the British Medical Association.

The New Postal Rates.

At the meeting of the Journal Committee on June 1st the Financial Secretary reported that the increased rates of foreign postage for printed papers, which the Postmaster-General proposes to bring into force on June 13th, would apply to copies of the BRITISH MEDICAL JOURNAL sent overseas, and would involve the Association in a considerable annual increase of expenditure. If the new rates are brought into effect the postage on a journal containing not more than 92 pages, sent overseas, would be 3d., and this would mean an additional payment for postage of more than £2,230 a year. The Financial Secretary stated further that so far as could be estimated this increase would not be obviated by the expedient of sending weekly parcels of the JOURNAL in bulk to Australia. The Journal Committee, recognizing the importance of this matter, asked its Chairman, the Treasurer, and the Editor, to take part in a deputation from all sections of the press which it was understood would wait upon the Prime Minister at an early date. The Prime Minister has not considered it expedient to receive a deputation. In these circumstances the British Medical Association has joined with the newspaper proprietors in making representations to the Postmaster-General.

Fee for Examination of Civil Service Candidates.

As long ago as July, 1920, the British Medical Association approached the Civil Service Commissioners with a view to raising the half-guinea fee paid by candidates for the Civil Service for examination on entry, and it was pointed out that in the opinion of the Association this fee should be a guinea. The Civil Service Commissioners replied that they saw no reason why candidates should be called upon to pay an increased fee. This reply was reported to the Medico-Political Committee, and it was decided to persist in the demand for an increase. The Commissioners were therefore informed that their reply was considered unsatisfactory, and that all the ordinary life offices were now paying a guinea for a medical examination not unlike that required by the Commissioners. The Commissioners then invited a representative of the Association to discuss the matter with them. At that interview the representative of the Commissioners pointed out that as the bulk of the candidates were now ex-service men any increase in the fee would bear hardly upon them. On behalf of the Association it was stated that medical remuneration for practically all services had been increased, and that this fee in particular had always been considered too low. The Commissioners promised to consider carefully the facts which had been put before them and give a decision at an early date. They have now reported that after due consideration they have decided to raise the fee to 15s. The Medico-Political Committee has accepted the offer, being of opinion that, in view of the strenuous campaign for economy which is going on, the result of the Association's action is not unsatisfactory.

The New Zealand Branch.

The twenty-fifth annual report of the New Zealand Branch states that during the past year sixty-six new members were added to the roll, and the membership of the Branch now numbers 660. The deaths are recorded with deep regret of Drs. T. Macallan, W. Kingston Fyfe, P. P. J. Stewart, A. Agnes Baird, T. S. Fleming, F. E. Meade, and G. J. Saunders. The new South Auckland Division, with headquarters at Hamilton, is now in working order. The quarterly meetings of the Council were well attended, and a considerable amount of business was transacted. For the meetings in Wellington and for office purposes a suitable room attached to the Art Gallery has been secured at a reasonable rental. The important question of a National Medical Service was fully discussed at the last annual meeting, when a valuable interim report, drawn up by a subcommittee appointed by the meeting, was adopted. Copies of the report, with a preamble by the editor of the *New Zealand Medical Journal*, were sent to the Minister of Public Health and to all members of the

New Zealand Branch. It is understood that the report will form the basis of any legislation that may be introduced dealing with national medical service. The Council expresses appreciation of a growing disposition on the part of the Government to consult the Association on all matters bearing on the health of the community. At the last annual meeting it was urged that the Model Agreement for Lodge Practice prepared before the outbreak of war should be launched forthwith, but after prolonged discussion it was resolved that the question of a general introduction of the model agreement throughout the Dominion should be deferred until the meeting at Napier in 1921. Members were, however, instructed that when new arrangements were being entered into with lodges they should follow closely the lines of the proposed model agreement. Other questions which arose during 1920 included hospital abuse, legislation for combating venereal diseases, a proposed Fellowship of Surgeons for New Zealand, a proposed co-operative supply depot for the Branch, a cadet movement, and the working conditions of nurses. Fully one-half of the members of the New Zealand Branch are stated to be subscribers to the New Zealand Medical Benevolent Fund. Necessitous cases arise from time to time among members of the profession or their families which, in the absence of such a fund, it would be impossible to assist without making special appeals to members. With regard to the Medical Defence Insurance Scheme, it is stated that members of the Branch, almost without exception, are now paying the annual premium of 8s., which entitles them to the benefits of the defence insurance policy. The report ends by recording that in June, 1918, the Branch Council resolved that at the termination of the war members who had been away from New Zealand on active service should be granted a refund of a large proportion of the subscriptions paid by them while so absent. Accordingly the sum of £342 has this year been refunded, with the anticipated result, that the statement of accounts shows an excess of expenditure over income. It is, however, regarded as highly satisfactory that the loss on the year's working is not more than £52, since the refunds extending over a period of five years had to be provided for in one year. During the whole of the war period the New Zealand Branch of the British Medical Association, in supporting the Government of the country, took its full share of responsibility. The endeavour of the Council has been to carry out its obligations with due regard to economy, and it is gratifying to find the Branch in the strong financial position it occupies to-day.

COUNCIL ELECTION.

THE names of the members already declared elected to the Council for 1921-22 in respect of the eight Groups of Branches in which there were no contests were published in the SUPPLEMENTS of May 21st (p. 192) and May 28th (p. 197). The following is the detailed result of the voting in the four groups where a contest took place:

Metropolitan Counties Branch.

The voting paper contained the names of six candidates for the four vacancies. The voting was on the single transferable vote system. Out of 2,839 voting papers issued, 732 were returned, of which 19 were spoilt, leaving 713 valid votes. The quota was therefore 143—that is, 713 divided by 5 (one more than the number of seats to be filled) plus one. The result of the first count was:

Dr. H. S. Beadles	143	Elected
Dr. C. Buttar	170	Elected
Lord Dawson of Penn	196	Elected
Mr. Bishop Harman	103	
Dr. Langdon Down	48	
Dr. William Paterson	53	

713

Dr. Beadles's votes equalling the quota, while Lord Dawson's and Dr. Buttar's exceeded the quota, all three were declared elected. Lord Dawson having the highest number it became necessary to transfer his surplus 53 votes. The whole of his 196 votes were examined, and the distribution of the 53 surplus votes according to the second preferences indicated resulted as follows:

Dr. Beadles	143	Elected	
Dr. Buttar	170	Elected	
Lord Dawson of Penn	53	...	143	Elected
Mr. Bishop Harman	34	...	137
Dr. Langdon Down	14	...	62
Dr. Paterson	5	...	58

713

No further candidate having secured the necessary quota of 143 votes, the next step was to transfer Dr. Buttar's surplus 27 votes. The whole of Dr. Buttar's 170 papers were examined and his 27 surplus votes distributed according to the second preferences indicated thereon, with the result that Mr. Bishop Harman secured the necessary quota and was declared elected:

Dr. Beadles	143	Elected		
Dr. Buttar	27	...	143	Elected	
Lord Dawson of Penn	143	Elected	
Mr. Bishop Harman	15	...	152	Elected
Dr. Langdon Down	9	...	71	
Dr. Paterson	3	...	61	

713

Birmingham and Staffordshire Branches.

The two candidates for the vacancy in connexion with the above Group were Dr. H. C. Mactier of Wolverhampton and Dr. W. A. W. Nuthall of Birmingham. Out of 851 voting papers issued, 346 were returned, two of which were spoilt. Of the remainder, 244 were in favour of Dr. Nuthall and 103 in favour of Dr. Mactier. Dr. Nuthall therefore becomes a member of Council for 1921-22.

Kent, Surrey, and Sussex Branches.

1,146 voting papers were issued to the members of this Group, the candidates being Dr. E. R. Fothergill of Hove and Dr. Arnold Lyndon of Hindhead, Surrey. 458 papers were returned, 260 being in favour of Dr. Fothergill, 193 in favour of Dr. Lyndon, five being spoilt. Dr. Fothergill therefore is elected.

Bath and Bristol, Gloucestershire, West Somerset, and Worcestershire and Herefordshire Branches.

The candidates here were Dr. H. C. Bristowe of Wriington, Somerset, and Dr. A. O. Holbeche of Worcester. 293 papers were returned out of 626 issued. Dr. Bristowe secured 229 votes, Dr. Holbeche 59, and two were spoilt. Dr. Bristowe is therefore elected.

Meetings of Branches and Divisions.

BATH AND BRISTOL BRANCH: BATH DIVISION.

THE annual meeting of the Bath Division was held on May 26th. The following officers were elected for the ensuing year:

Chairman: Dr. A. E. Norburn. Vice-Chairman: Dr. J. Wigmore. Secretary and Treasurer: Mr. W. G. Mumford. Representative in Representative Body: Dr. N. Lavers. Deputy Representative: Dr. R. G. Gordon.

The Annual Report of the Central Council was discussed and the Representative was instructed to oppose any resolution in favour of paying patients being taken into Poor Law infirmaries, as the meeting considered this to be detrimental to the continuance of the voluntary system. The Representative was also instructed to support the proposal for the formation of a Central Medical Committee as representative of the whole profession.

DORSET AND WEST HANTS BRANCH.

THE annual meeting of the Dorset and West Hants Branch was held at Yeovil on March 18th. The following resolution was adopted:

"This meeting approves the resolution of the last Annual Representative Meeting, in respect of the payment of members of staffs of voluntary hospitals, for the treatment of discharged and disabled soldiers and sailors, and affirms the principle of adequate remuneration by the State for the treatment in voluntary hospitals of all State or rate-aided patients for whom the State has accepted responsibility."

The presidential address was delivered by Dr. F. C. BOTTOMLEY, O.B.E., on "Experience of two recent methods of treatment," and was highly appreciated.

At the close of the meeting, which was attended by thirty-six, the members were entertained to tea by the kind invitation of Dr. Norman Flower.

DORSET AND WEST HANTS BRANCH: BOURNEMOUTH DIVISION.

AT the annual meeting of the Bournemouth Division, held on May 13th, the following officers were elected for the coming year:

Chairman: Dr. A. Humphry Davy. Vice-Chairman: Dr. C. B. Thomson. Representative in Representative Body: Dr. E. K. Le Fleming. Deputy Representative in Representative Body: Dr. A. G. S. Mahomed. Honorary Secretary and Treasurer: Dr. E. C. Bond.

On the motion of Dr. W. ASTEN, seconded by Dr. J. F. BRISCOE, the following resolution was passed, and directed to be forwarded for inclusion on the Agenda of the forthcoming Representative Meeting:

That the Representative Body supports the recommendations contained in the Interim Report of Lord Cave's Committee with reference to the disposal, in the interest of hospitals, of the surpluses of approved societies; that it instructs the Insurance Acts Committee to approach the Ministry of Health and the approved societies with a view to establishing upon a just basis a satisfactory method of payment by the approved societies to the various hospitals for their treatment of insured persons.

METROPOLITAN COUNTIES BRANCH: HARROW DIVISION.

At a meeting of the Harrow Division held on May 31st the following officers were elected for 1921-22:

Chairman: Dr. H. J. Hildige. *Vice-Chairman:* Dr. C. E. Goddard, O.B.E. *Representative in Representative Body:* Dr. H. L. Hatch. *Honorary Secretary:* Dr. C. F. Mayo, O.B.E.

Mr. H. S. SOUTAR gave a most interesting and lucid exposition of the National Provident Scheme for Hospital and Additional Medical Services. A free discussion followed, and the meeting concluded with a hearty vote of thanks to Mr. Soutar for his attendance.

On May 25th the Division gave a farewell dinner to Dr. H. S. Wansbrough Jones, prior to his retirement from practice and the district. There was a gathering of about twenty, and a very pleasant evening was spent. The chairman of the evening, Dr. S. H. A. LAMBERT, in a happy speech proposed the health of the guest of the evening, and presented him with a gold wristlet watch, the gift of members of the Division. Dr. JONES, in his reply, referred to the twenty-five years he had practised in Harrow, and laid stress on the influence of the British Medical Association in cementing the practitioners of the district together.

METROPOLITAN COUNTIES BRANCH: KENSINGTON DIVISION.

THE annual general meeting of the Kensington Division was held on May 23rd.

The following officers were elected:

Chairman: Dr. W. E. Fry. *Representatives in Representative Body:* Mr. E. B. Turner, Dr. Christine Murrell, Dr. F. C. Martley. *Deputy Representatives:* Dr. W. E. Fry, Mr. H. M. Stratford. *Representatives on Branch Council:* Drs. A. J. Rice-Oxley, C.B.E., H. Sanguinetti, H. Tanner, C. Buttar, and H. M. Stratford. *Honorary Secretary and Treasurer:* Dr. F. C. Martley.

The following resolution was directed to be transmitted to the Annual Representative Meeting:

That it be an instruction to the Council to report whether additional medical services instituted or paid for by the State or Municipality should be open to all members of the community, and if so, on what terms or arrangements as to payment.

NORTHERN COUNTIES OF SCOTLAND BRANCH: BANFF, ELGIN, AND NAINN DIVISION.

THE annual meeting of the Division was held at Elgin on May 13th. The following office-bearers were elected for the year:

President: Dr. Hendry. *Vice-President:* Dr. George Wilson. *Honorary Secretary and Treasurer:* Dr. Robertson. *Representative in Representative Body:* Dr. Cruickshank. *Deputy Representative in Representative Body:* Dr. Beaton.

A vote of thanks was accorded to Dr. Sellar in appreciation of his valuable work as honorary secretary and treasurer.

The meeting had under consideration the proposals for federation, and it was the general feeling that the Representative should be asked to vote for the scheme whereby medical men only are included.

NORTH OF ENGLAND BRANCH: CLEVELAND DIVISION.

A MEETING of the Cleveland Division was held on May 26th. The following office-bearers were elected for 1921-22:

Chairman: Mr. W. S. Dickie. *Chairman-elect:* Dr. James Donaldson. *Honorary Secretary and Treasurer:* Dr. G. H. Lowe. *Representative in Representative Body:* Dr. G. H. Lowe. *Deputy Representative:* Dr. J. Brownlee.

The following motion was adopted and directed to be forwarded to the Annual Representative Meeting:

That the fee for suturing perineum, for removal of adherent or retained placenta, for exploration of the uterus, for the treatment of post-partum haemorrhage, or for any operative emergency arising directly from parturition, including all subsequent necessary visits during the first ten days, inclusive of the day of birth, should be increased from one guinea to two guineas. That the fee for attendance at or in connexion with an abortion or miscarriage, including the subsequent visits during the ten days after, and including the first visit, should be increased from one guinea to two guineas.

The HONORARY SECRETARY reported that the Middlesbrough Watch Committee had increased the fees payable to medical practitioners called by the police to street accidents or other emergency to 7s. 6d. between 8 a.m. and 8 p.m., and 15s. between 8 p.m. and 8 a.m.

SOUTH MIDLAND BRANCH: NORTHAMPTON DIVISION.

At the annual meeting of the Northampton Division held on May 24th the following officers were elected:

Chairman: Dr. W. E. Andland. *Vice-Chairman:* Dr. L. Dryland. *Honorary Secretary:* Dr. W. M. Robson (re-elected). *Representative in Representative Body:* Dr. J. P. Roughton. *Deputy Representative:* Dr. D. G. Greenfield. *Representatives on Branch Council:* Drs. Arthur, More, and Smart.

With regard to fees under the Lunacy and Mental Deficiency Acts it was agreed to ask for £1 ls. in all cases, which appeared to be the usual one paid in the Division.

SOUTH-WESTERN BRANCH: WEST CORNWALL DIVISION.

At a meeting of the Division the following resolution was adopted on the report of the Council regarding federation:

That the West Cornwall Division of the British Medical Association regrets the action of the Council of the Association in omitting from list of representative bodies the Medico-Political Union and

the Northern Medical Union. It feels strongly that these two bodies represent a considerable number of colleagues in general practice, and, therefore, they should be invited to join any body formed to represent the medical profession.

STAFFORDSHIRE BRANCH: SOUTH STAFFORDSHIRE DIVISION.

A MEETING of the South Staffordshire Division was held on May 31st. The following officers have been elected for 1921-22:

Chairman: Dr. F. A. Cooke. *Vice-Chairman:* Dr. F. R. Turton. *Hon. Secretary and Treasurer:* Dr. H. C. Macler, M.B.E. *Representative in Representative Body:* Dr. H. C. Macler. *Deputy Representative:* Dr. R. D. Bailey.

Dr. F. C. Craig was nominated a member of the Wolverhampton After Care Committee, in place of the late Dr. J. A. Codd.

The annual report of the Central Council was considered and the Representative instructed to move an amendment in connexion with Section 45 of the report, referring to members of Council and membership *ex officio* of Branch Council.

A vote of thanks to the retiring Chairman, Dr. F. R. Turton, was carried with acclamation.

SURREY BRANCH: CROYDON DIVISION.

THE annual meeting of the Croydon Division was held at the Croydon General Hospital on May 25th, when Dr. E. F. S. GREEN was in the chair.

A vote of condolence was passed to the family of the late Dr. Peter Duncan.

The following officers were elected for 1921-22:

Chairman: Mr. G. E. Newby, O.B.E., F.R.C.S. *Vice-Chairman:* Dr. E. F. S. Green. *Honorary Secretary:* Dr. C. G. C. Scudamore. *Representative in Representative Body:* Dr. C. G. C. Scudamore. *Deputy Representative:* Dr. G. G. George.

It was resolved to hold later a meeting to discuss the annual report of the Central Council and to instruct the Representative.

A clinical meeting was then held, under the chairmanship of Mr. CHARLES WRAY, F.R.C.S., when a series of exhibits were shown.

SUSSEX BRANCH: HASTINGS DIVISION.

THE recently-resuscitated Hastings Division held a very successful meeting on June 3rd at the Albany Hotel. All medical men in the Division area and their wives were invited, and there was a good attendance. There was a short address by the Chairman, Dr. J. D. HESSLY, and an excellent musical programme, followed by light refreshments. During the evening Dr. L. A. PARRY, of Hove, by invitation gave an address on the work of the British Medical Association, and on the motion of the Secretary of the Division, Dr. CHARNOCK SMITH, he was accorded a hearty vote of thanks.

MEETINGS TO BE HELD.

BIRMINGHAM BRANCH: CENTRAL DIVISION.—The annual meeting of the Central Division will be held at 18, Bennett's Hill, on Thursday, June 16th, at 3.45 p.m. Agenda: To instruct Representatives. To elect officers for ensuing year. Nominations for officers must be in the hands of the Honorary Secretaries fourteen days before the meeting. Members are requested to bring with them copies of the SUPPLEMENT of April 30th.

CAMBRIDGE AND HUNTINGDON BRANCH.—The seventy-seventh annual meeting of the Branch will be held at Harlech House, Burwell, on Friday, July 1st, at 12.30 p.m., when the financial statement for the past year will be presented and the officers for 1921-22 elected. Luncheon, by the kind invitation of the president-elect, Mr. O. R. Ennion, will be served in the Gardner Memorial Hall at 1.30 p.m. At 2.45 p.m. Mr. Ennion will deliver his presidential address, entitled "With the field ambulance at Gallipoli." At 4 p.m. Mr. and Mrs. Ennion will be "At home" at Harlech House.

EAST YORKS AND NORTH LINCOLN BRANCH.—The sixty-fifth annual meeting of the above Branch will be held at Grimsby on Friday, July 15th. The place and hour of meeting will be announced later. Business: Election of officers and presidential address. Nominations must be in the hands of the honorary secretary before July 1st.

METROPOLITAN COUNTIES BRANCH.—The annual general meeting of the Metropolitan Counties Branch will be held at 429, Strand, W.C., on Friday, June 24th, at 4 p.m. Business: (1) Report of scrutineers as to the election of new officers. (2) Annual Report of Council. (3) Alteration in Rule 11 by the insertion of words providing that such members of the Branch as are members of the Central Council shall be *ex officio* members of the Metropolitan Counties Branch Council. (4) President's address by Dr. H. B. Brackenbury, on "The Psychologist in Public Life."

METROPOLITAN COUNTIES BRANCH: HAMPSHIRE DIVISION.—The annual meeting will be held at the Hampshire General Hospital, Haverstock Hill, on Thursday, June 16th, at 5 o'clock. Agenda: (1) Elect officers and members of the Executive Committee for the ensuing year. (2) Receive annual report of the Executive Committee. (3) Consider business of the Annual Representative Meeting. (4) Other business. Tea at 4.45 p.m.

OXFORD AND READING BRANCH.—The annual meeting of the Branch will be held at Maidenhead on Wednesday, June 29th, at the Town Hall. Any members wishing to show cases or read

notes should communicate with Dr. E. W. Squire, 223, King's Road, Reading, before June 19th. Dinner will be arranged afterwards at one of the riverside hotels. Those intending to be present and having room in their cars or requiring a lift are asked to write to the secretary.

SOUTH WALES AND MONMOUTHSHIRE BRANCH.—The annual meeting of the South Wales and Monmouthshire Branch will be held at the Council Chamber, Barry, Glamorganshire, on Thursday, June 23rd, at 3.30 p.m.

SOUTH-WESTERN BRANCH.—The eighty-first annual meeting of the Branch will be held on Wednesday, June 15th, at the White Hart Hotel, St. Austell, at 3.15 p.m., when Dr. Jonas will resign the chair to Dr. Shaw, who will deliver his inaugural address. The report of the Branch Council for 1920-21 and the annual financial statement for 1920 will be presented and the Branch officers will be elected for 1921-22. Luncheon, by the kind invitation of the President-elect, will take place from 1 to 2.15 p.m., at the hotel. Dr. Shaw asks those intending to be present to send him written acceptance. The annual dinner of the Branch will be held at 7.45 p.m. at the hotel. Tickets, 10s. 6d. each (exclusive of wine), can be had from Dr. W. Gilchrist, High Cross House, St. Anstell; early application is desired. Golf and bowls and excursions can be arranged. Mrs. Shaw will be at home at "Ardmore" at 4.30. Several St. Austell members are willing to accommodate visitors for the night, while there will also be accommodation at the hotel.

SURREY BRANCH.—The annual meeting of the Surrey Branch will be held at Guildford on Friday, July 8th.

SUSSEX BRANCH: HASTINGS DIVISION.—A general meeting of the Hastings Division will be held at the Eversfield Hotel, Hastings, on Tuesday, June 14th, at 4.30 p.m.

WORCESTERSHIRE AND HEREFORDSHIRE BRANCH.—The annual meeting of the Worcestershire and Herefordshire Branch will be held at the Infirmary, Worcester, on June 30th, at 3 p.m.

YORKSHIRE BRANCH: SHEFFIELD DIVISION.—A general meeting of the Sheffield Division will be held at the Church House, St. James Street, Sheffield, on Friday, June 17th, at 8.30 p.m. Agenda: Consider Report of Council and instruct Representatives. Members are requested to bring with them the SUPPLEMENT of April 30th.

MALAYA BRANCH.—Meetings of the Malaya Branch are held in Singapore on the third Thursday of each month. Members desiring to contribute papers are requested to communicate with the honorary secretary, Dr. J. W. Scharff, care of Port Health Office, Singapore. Arrangements can be made for the exhibition of specimens or cases of interest brought to the meetings.

Association Notices.

REPRESENTATIVE MEETING.

DATE.

THE Annual Representative Meeting at Newcastle will begin on Friday, July 15th, 1921, at 10 a.m.

NOTICES OF MOTION AND AMENDMENT BY DIVISIONS AND BRANCHES.

The Supplementary Report of Council to the Representative Meeting will appear in the SUPPLEMENT of July 2nd, 1921.

Notices of Motion and Amendment by Divisions and Branches for consideration by the Annual Representative Meeting will be published in the SUPPLEMENT as they are received, but none can be published later than July 2nd, for which purpose they must be received by the Medical Secretary not later than the first post on Monday, June 27th.

It will be possible, however, to include in the Agenda for the Annual Representative Meeting all Notices of Motion and Amendment which are received by the Medical Secretary *not later than the first post on Monday, July 4th, 1921.*

NOTICES OF MOTION BY DIVISIONS FOR THE ANNUAL REPRESENTATIVE MEETING, NEWCASTLE, 1921.

By BEDFORD DIVISION:

That new members be elected by a general meeting of the Division in which they reside, and not by the Branch Council.

By KENSINGTON DIVISION:

That it be an instruction to the Council to report whether additional medical services instituted or paid for by the State or municipality should be open to all members of the community, and if so, on what terms or arrangements as to payment.

By CAMBRIDGE AND HUNTINGDON DIVISION:

That, with reference to paras. 65, 66, and 85 of the Annual Report of Council (SUPPLEMENT, April 30th, 1921, pp. 112, 114, 115), it be an instruction to the Council to make provision so that a postal vote on any question of policy or otherwise may be taken by any Branch or Division after the question has been discussed at a meeting of that Branch or Division, and if the members present at that meeting deem such a vote desirable.

By Dr. C. O. HAWTHORNE (Marylebone):

That the recommendation included in para. 55 of the Annual Report of Council (SUPPLEMENT, April 30th, 1921, p. 112) be amended to read as follows:

"That it be an instruction to the Council to take steps to redraft By-law 26 so that after the word 'expenses' (line 3) the by-law shall read, 'and shall pay to each of its constituent Divisions the sum necessary to meet the ordinary expenses of the Division. In addition, the Branch Council may on application from any Division included within the area of the Branch, and on conditions defined by the Branch Council, make an additional grant or grants to a Division in order to meet any extraordinary expenses contemplated by the Division. In the event of the Branch Council refusing an application of this order it shall be open to the Division concerned to appeal against the decision to the Council of the Association.'"

By CLEVELAND DIVISION:

That the fee for suturing perineum, for removal of adherent or retained placenta, for exploration of the uterus, for the treatment of *post-partum* haemorrhage, or for any operative emergency arising directly from parturition, including all subsequent necessary visits during the first ten days inclusive of the day of birth, should be increased from one guinea to two guineas.

By CLEVELAND DIVISION:

That the fee for attendance at or in connexion with an abortion or miscarriage, including the subsequent visits during the ten days after, and including the first visit, should be increased from one guinea to two guineas.

By SOUTH STAFFORDSHIRE DIVISION:

That Recommendation 45 of the Council (SUPPLEMENT, April 30th, 1921, p. 110) be amended to read as follows:

"That it be an instruction to the Council to take steps for amendment of By-law 16 (a) so as to provide that the Branch Councils in the United Kingdom shall include as members *ex officio* the twenty-four members of the Council elected under By-law 45, but shall not include those elected by the Representative Body except resident in the area of that Branch."

By BOURNEMOUTH DIVISION:

That the Representative Body supports the recommendations contained in the interim report of Lord Cave's Committee with reference to the disposal in the interests of hospitals, of the surpluses of approved societies; that it instructs the Insurance Acts Committee to approach the Ministry of Health and the approved societies with a view to establishing upon a just basis a satisfactory method of payment by the approved societies to the various hospitals for their treatment of insured persons.

By SOUTH SUFFOLK DIVISION:

That the British Medical Association be asked to reconsider the question of the treatment of school children by the education authorities, with a view to the more general employment of the general practitioner.

LIBRARY OF THE BRITISH MEDICAL ASSOCIATION.

A LIST of periodical publications, official reports, and Blue Books in the Library of the British Medical Association available for issue to members on loan has been printed, and copies can be obtained free on application to the Librarian at the house of the Association, 429, Strand, W.C. The regulations governing the loan of these publications are stated in the introduction to the list. The Library is open for consultation from 10 a.m. till 6.30 p.m. (on Saturdays 10 a.m. till 2 p.m.).

GENERAL COUNCIL

OF

MEDICAL EDUCATION AND REGISTRATION.

SUMMER SESSION, 1921.

Sir DONALD MACALISTER, K.C.B., President,
in the Chair.

MEDICAL EDUCATION REGULATIONS.

DR. MACKAY (Chairman of the Education Committee) called attention, on May 24th, to the changes which had been made in the Council's regulations consequent upon the decisions of the Council arrived at last session, and fully reported in the *BRITISH MEDICAL JOURNAL*, December 4th, 1920 (page 150). He read the revised copy of the regulations now sent to medical schools and intending students.

RESULTS OF QUALIFYING EXAMINATIONS.

DR. NORMAN WALKER presented a report of the Examination Committee containing an analysis of the annual tables for 1920. As a result of the resolution of the Council passed a year ago, the information supplied by licensing bodies as to whether they did or did not examine in operative surgery, ophthalmology, and mental diseases, was now complete so far as it went. Of the 23 bodies granting primary qualifications, eight gave passes and rejections in operative surgery, and six stated that it was included under surgery; nine gave passes and rejections in ophthalmology or ophthalmic surgery, and three stated that it was included under surgery; ten gave passes and rejections in mental diseases, and six stated that it was included under medicine. The others in each case stated that there was no examination or no special examination in these subjects. The table dealing with exemptions showed these to be exceptionally numerous; many of these were due directly or indirectly to the war, others to increasing readiness to accept the examinations of other bodies. With regard to the Council's inspection of final examinations, this was not yet completed. That in medicine was almost finished, but there were still seven bodies to be inspected in surgery and eight in midwifery.

The report was adopted.

INSPECTION OF PUBLIC HEALTH EXAMINATIONS.

Sir JOHN MOORE submitted the report of the Public Health Committee. The annual returns of professional examinations held in 1920 for diplomas in public health showed that 453 candidates were examined for the first examination, of whom 342 passed and 111 were rejected, and that 463 candidates presented themselves for the second and final examination, of whom 373 were successful and 90 failed. During the year the English Conjoint Board had granted exemptions from the rules of the Council in regard to such diplomas to seven out of 142 candidates, the University of Liverpool to eight out of 33 candidates, and the Victoria University of Manchester to one out of 43. The Committee deferred its detailed remarks on the inspection of examinations until this inspection had been completed. It was hoped to present to the Council at the next session a final report on this inspection and on the proposed revision of the resolutions and rules for diplomas in public health which would issue therefrom. He moved that a special meeting of the Public Health Committee be sanctioned for the last week in September with a view to the preparation of a considered report to lay before the Council.

Dr. J. C. McVAIL, in seconding this motion, said that there were a number of questions relating to the practical training and examination of the medical officer of health to be considered—whether, for example, too much attention was devoted to sanitary law and too little to vital statistics—and it would be impossible to dispose of all these matters in an ordinary session of the Council unless the Committee was prepared beforehand to give a lead with definite proposals.

The motion was agreed to, and it was understood that the matter would be fully debated at the November session.

DENTAL EDUCATION AND EXAMINATION.

Sir JAMES HODSDON submitted the report of the Dental Education and Examination Committee. He said that at the last session the Council passed certain resolutions relating to the educational requirements at the registration of medical students, to come into operation on January 1st, 1923. If any of these resolutions were to

apply to dental students it was important that the existing rules on this subject should be modified accordingly during the present session. The Departmental Committee on the Dentists Act (February, 1919) considered it essential that a student in ordinary circumstances should have passed a preliminary examination in general education, which should be the same for dental as for medical students, that a student who had completed a course of study at a secondary school up to the age of 18 would probably be in a better position to profit from a course of professional study than a student at 16, the age at which dental students might commence such study, and, further, that a course of study in chemistry and physics should form a portion of the normal school course. These recommendations were similar to the resolutions of the Council in regard to professional education in general, and his Committee, therefore, was of opinion that the preliminary examination and registration required of candidates for licences in dentistry or dental surgery should be the same for dental students as for medical students, and that the resolutions of the General Medical Council of 1898 be modified so as to provide:

I. (a) That before registration in the Dental Students' Register every applicant shall be required to have passed, in addition to the examination in general education, an examination in elementary physics and elementary chemistry conducted or recognized by one of the licensing bodies. (b) That before registration as a dental student every candidate shall produce evidence that he has attained the age of 17 years. Provided that the minimum standard of general education required by the Council for registration as a dental student should be raised to a standard equivalent to that demanded in other learned professions previously to, or concurrently with, the coming into operation of the requirements of a preliminary examination in science before registration.

II. That the requirements contained in the above recommendation come into operation on January 1st, 1923.

Dr. J. T. MACKAY heartily supported the recommendation of the Committee that the preliminary examination required of candidates should be the same for dental students as for medical students. All educational bodies in the country were raising the standard of preliminary education required among those who were intending to enter the learned professions, and the action of the Council, if it carried into effect the recommendation of the Committee, would be in a line with this policy.

The report was received and the recommendation adopted.

STUDENTS' REGISTRATION.

Sir NORMAN MOORE moved, and Dr. MACKAY seconded, the reception of the report of the Students' Registration Committee, which was merely a statement of seven applications for registration and antedating of professional studies under exceptional circumstances, and the manner in which each case had been dealt with. Since the previous report in November, 101 medical students and 27 dental students had had their registration antedated in accordance with precedent.

The report was received.

RECOGNITION OF EXAMINATIONS.

Dr. J. T. MACKAY (Chairman of the Education Committee) informed the Council that his Committee had recognized the shortened Matriculation Examination of the University of London, and also the Senior Public Examination of the University of Queensland, and that these would be inserted in the list of examinations recognized by the Council when next published.

ELECTIONS TO COMMITTEES.

The following were elected members of Committees on the nominations of the Branch Councils:

Education Committee.—Sir Francis Champneys, Dr. Howden, Sir Norman Moore (England); Sir James Hodsdon, Dr. Mackay, Professor Littlejohn (Scotland); Sir Arthur Chance, Dr. Dixon, Mr. Sinclair (Ireland).

Examinations Committee.—Sir Gilbert Barling, Dr. Caton, Dr. J. A. Macdonald (England); Dr. Adams, Dr. Russell, Dr. Norman Walker (Scotland); Sir Arthur Chance, Dr. Coffey, Sir John Moore (Ireland).

Public Health Committee.—Dr. Dean, Sir George Newman, Sir Jenner Verrall (England); Dr. Matthew Hay, Professor Littlejohn, Dr. McVail (Scotland); Sir E. Coey Bigger, Dr. Mageunis, Sir John Moore (Ireland).

APPOINTMENT OF REGISTRAR.

On the proposition of Dr. NORMAN WALKER, Colonel Norman C. King was re-elected by acclamation registrar for another year. The Council afterwards considered certain matters *in camera*, as to which no public statement was issued, and then concluded its proceedings after the shortest session of recent years.

Correspondence.

Dr. Macdonald's Mission to South Africa.

SIR,—The letter of Drs. Mackenzie and Napier which appeared in the SUPPLEMENT of May 28th (p. 202) is justified in that, in the report to Council of my visit to South Africa in the issue of March 12th (p. 70), there is clearly a misrepresentation of what took place at the Durban conference. I need hardly say that this was unintentional, and was probably due to the fact that my report was verbal, and therefore liable to be inaccurate.

If Drs. Mackenzie and Napier will take the trouble to transfer the words "A keen discussion took place during which" from where they stand to the sentence beginning "Dr. Macdonald said," etc., they will see what it was my intention to convey to the Council. These words being thus transferred the true context of the intermediate sentences will be evident. This, however, does not in any way justify my error, and I trust these gentlemen will accept my apologies for the misrepresentation.

I cannot, however, accept the statement that I entirely misunderstood the position of the Witwatersrand Branch; I think I had a very clear conception of it. I never referred to the Witwatersrand Branch as a Branch. I stated that the movement to form a new association originated in the Branch, and I think that is true. Surely Dr. Napier was the great protagonist of that movement.

Drs. Napier and Mackenzie argue in their letter with regard to the deliberations of the Joint Committee. I did not deal with that period at all. I stated that in the movement to establish a new association two strong planks in the platform of the originators were the inability of the British Medical Association to carry on collective bargaining and the necessity for the new association being on the lines of a trade union. In confirmation of these statements let me quote a few speeches of Dr. Napier:

The Committee appointed by the Witwatersrand Branch, of which Dr. Napier was the convener, reported (*Medical Journal of South Africa*, August, 1919, p. 20) that in dealing with contract practice "in future it must be a question of collective bargaining . . . public and private bodies requiring the services of medical men . . . must come to terms with the medical profession as a whole or its mouthpiece as to the nature of the services required. This result can only be obtained by co-operation, association or union. Whichever name it be called by the objects are identical. It cannot be accomplished through the British Medical Association." Dr. Napier in his introductory speech frequently spoke of the necessity of forming "a union." "Trade unionism only exists practically amongst skilled trades, and in England it has never numbered 50 per cent. of those engaged in skilled trades. Yet look at the control it has over the trade conditions of the United Kingdom. We could do exactly the same. If we go to other unions and say: 'This union is for the improvement of conditions of work; it not only affects us but you, because as we improve the conditions of our work we also improve the conditions of work with reference to yourselves'; do you suppose we shall not get their support?" In his speech at a meeting of the Witwatersrand Branch, October 16th, 1919, Dr. Napier spoke of the two functions of the proposed new association—(1), a medical and scientific body, and (2), "the function of a trade union." Later he said: "Collective bargaining must be to any body of men of greater value than individual bargaining. . . . The difficulty is that the British Medical Association cannot do it for us." "What your Committee [of which he was convener] is contemplating is quite evidently of the nature of a trades union because collective bargaining is the essence of trades unionism, and it is evident that the British Medical Association cannot help us." Dr. Irvine asked if it was proposed that the new association should join the Federation of Trades. Dr. Napier: "I am not proposing that at present. Personally I should be satisfied to do it."

At the first meeting of the South African Medical Association held on November 15th, 1919 (reported in the *Medical Journal of South Africa*, November, 1919) Dr. Napier was elected president and was reported as saying, "One of the objects of our association is to adopt the principles of trade unionism."

Other people are evidently of the same opinion as I am. For example, Dr. J. A. Mitchell, in proposing the toast of "the British Medical Association and the Medical Profession in South Africa" at the annual dinner of the Witwatersrand Branch, said (*Medical Journal of South Africa*, January, 1920, p. 145), in speaking of the new association, "Its main objects seem to be the organization of the profession on trade union lines."

Sir Spencer Lister, in a discussion at the Witwatersrand Branch, July 29th, 1920 (*Medical Journal of South Africa*, p. 270), said, "Originally Dr. Napier was very keen on the trade union principle; now he told them that there were to be no trade

union objects in the constitution; nevertheless the bulk of the profession still believed that the principal plank of the South African Medical Association was trade unionism."

With regard to the last paragraph of the letter by Drs. Mackenzie and Napier:

No. 1. I do not propose to touch this; it is a question the South African men understand, but I don't.

No. 3. I am delighted to know that they do not want a trade union, and should have been much disappointed if either of the signatories did want it.

No. 2. With regard to this, I fear it is a dream not likely to be realized; in addition, it is a little contradictory of 3, as surely an Association which can force its members to obey its decision is a trade union *in excelsis*. I cannot believe that any association of private citizens would be granted a Memorandum of Association which would confer that power. Besides, the members could at any time resign.

I regret exceedingly that this incident has arisen through my carelessness; it tends to cast a cloud over the memory of a visit, during which everyone showed me the height of courtesy and kindness.—I am, etc.,

Taunton, June 6th.

J. A. MACDONALD.

Hospital Treatment of Insured Persons.

SIR,—Ever since the issue of the Report by the Consultative Council on Medical and Allied Services, and the discussion of that report by the Divisions, there has been a difficulty which I foresee will become more and more prominent as the scheme outlined in the report is slowly but gradually realized. I refer to the question of the remuneration of panel practitioners for services rendered to their insured patients while inmates of a primary health centre. This difficulty is also being brought prominently forward in connexion with schemes for extending hospital accommodation so as to admit paying patients, and also by the present financial straits of the voluntary hospitals. Here it is beginning to be realized that when a hospital treats an insured person it ought to be paid for so doing, and that the surplus funds of friendly societies should be drawn upon for that purpose. It has also been suggested that the panel practitioner should surrender a portion of his capitation grant for those of his insured patients who are being treated at a general hospital.

The majority of panel practitioners are dissatisfied with the terms the British Medical Association obtained for them during the recent negotiations with the Ministry of Health. I believe this has been due, to a large extent, to the apathy of individual members. They do not bestir themselves until the last moment and then they expect to find a good case already prepared for them, safeguarding all their most cherished interests. This turns out to be impossible in the time left, and a hurried, imperfect case is presented. Then when a new agreement is brought out its imperfections are only too plain and there are shoals of abusive and complaining letters. But it is *too late* then; the thing is arranged and to have it altered would break the agreement. Again, the Insurance Acts Committee, and also the individual practitioners, do not appear in many instances to be able to visualize where certain clauses of an agreement lead to, where a certain method of presenting their case may be used against the interests of those they represent, at some future time and in connexion with matters which everybody knows are going to crop up in the very near future. You have only to read the Insurance Acts Committee's arguments during the last negotiations with the Ministry to get a splendid example of what I mean. Panel practitioners' lists are now limited to 3,000, with powers to make it any less figure, and it is admitted by the Insurance Acts Committee that that is all that a panel practitioner can properly attend to. How now if the Ministry extend the scope of the Insurance Act? I leave it to panel practitioners with lists bordering upon 3,000 to think how they will be placed should the Acts be extended.

The capitation grant was fixed with certain conditions in existence. A panel practitioner always has a certain number of his panel patients in hospital. He is therefore doing less work—that is, earning his grant more easily—than he would have to do had there been no hospitals. Not only this, but the amount of time and labour spent upon his patients varies directly with the facilities at his disposal for doing the thousand and one things that could be done in a primary health centre.

In order to make my meaning quite clear, for I think the point is of immense importance, I will mention some of the things a "general practitioner of ordinary professional competence and skill" could do with a hospital bed at

the disposal of each of his panel patients: washing out stomach, analysis of stomach test meals chemically and bacteriologically, examination of pathological fluids, excretions, secretions, examination of heart cases with polygraph, x ray examinations, methods of treatment only applicable under skilled observation. There are innumerable things he could do in the hospital. And, mark you, this list always tends to grow, for, as medical science progresses, new and simpler methods are found for doing this or that test, new methods of treatment requiring skilled observation over an extended period are discovered. I dare say a few panel practitioners do a few of these things for a few of their patients already. But what is done is very little to what could and ought to be done now the capitation fee is fixed in relation to the existing facilities for doing this kind of work.

If these facilities are to be largely increased by dotting the whole country with primary health centres, the panel practitioner will be compelled, by competition alone, to make use of them to the full and do all these things, and up will go the time spent on his panel patients but with no corresponding monetary return.

The argument of Dr. Charles E. S. Flemming in the SUPPLEMENT of May 28th, p. 202, that institutional treatment cures the patient quicker and so requires less attendance by the medical man, is not valid in the conditions under which the panel practitioner works. Most of the ailments I am referring to are chronic and incurable, and the panel patient attends his doctor for a time, and either gets patched up for a while, or gets tired of attending and receiving no appreciable benefit and jogs along with his own home remedies. But the time and trouble involved in the present method of treating, in their own homes or at the practitioner's consulting rooms, chronic gastric complaints, for example, is much less than the time and trouble involved in treating the same patients adequately and with all the resources of a hospital at his disposal. And for this extra time and trouble the panel practitioner ought to be paid, even although the work is within his ordinary competence and skill, for his remuneration was computed according to a certain state of affairs with regard to the time occupied, with regard to the general habit of panel practitioners in doing certain things for their patients, and with regard to the limitation of his ordinary competence and skill, by the conditions under which he carried out his work. If now, without altering other things the facilities for exercising his ordinary competence and skill are to be greatly increased, then he ought to be remunerated in strict accord with the new conditions.—I am, etc.,

Pelaw-on-Tyne, June 1st.

A. BENJAM STICH.

INSURANCE.

POSITION OF INSURANCE ACTS COMMITTEE.

THE following circular letter (M. 31) has been addressed by the Medical Secretary to the Honorary Secretaries, Chairmen, and Representatives of Local Medical and Panel Committees, and (for their information) to the Honorary Secretaries of Divisions and Branches of the British Medical Association:

British Medical Association,
Medical Department.

The attention of the Insurance Acts Committee has been drawn to the issue to all Panel Committees of a circular by the Association of Panel Committees, urging those committees to drop their connexion with the Insurance Acts Committee and form a new body to be elected directly and solely by Panel Committees. The Association of Panel Committees encloses a copy of its circular issued in February, 1918. To this a reply was issued by the Insurance Acts Committee on February 23rd, 1918, of which I enclose a reprint (M. 22, 1917-18). The only material alteration required in that reply is that the larger number of direct representatives of Panel Committees the Committee then suggested is now an accomplished fact. The Insurance Acts Committee stands by its 1918 circular, and requests Panel Committees to give it their careful consideration. As many copies of it as are required will be sent to any Panel Committee asking for them.

I am instructed to add the following points:

(A) The Insurance Acts Committee has been the authorized mouthpiece of insurance practitioners since the service came into being. It has not, of course, secured for those practitioners all it has tried to obtain, but it can claim a very large measure of success, due to the loyal support of its constituents.

(B) The advocates of a new body have taken advantage of nearly every conference to try to upset the position of the

Insurance Acts Committee, and have been heavily defeated on every occasion. In October last a straight vote was taken on the following motion, and the advocates of the new body got only 16 votes out of the 125 representatives present:

That in place of the Insurance Acts Committee as the negotiating body an independent and directly elected body be constituted, this body to be nominated by the Annual Conference of the Representatives of Panel and Local Medical Committees of the country.

As these conferences are freely elected by the Local Medical and Panel Committees of the country, no limitation being put on them that their representatives shall be members of the British Medical Association, the onus of bringing forward new facts to influence the Panel Committees to override the decision of the conference lies on the advocates of the new body. No new facts are given in their latest circular.

(C) Panel Committees should examine very carefully the finance of the revived proposal. It is doubtful how far the statutory funds of Panel Committees could be used for all the needs of such a new body. The attempts to raise money by a voluntary fund have not so far been encouraging. The Committees concerned in the new proposal have held aloof from the National Insurance Defence Trust, and there is no certainty that they could be relied upon for regular and sufficient financial support, even if their proposal were adopted.

(D) The Insurance Acts Committee has gradually acquired a status with the Government and the Ministry of Health which is of the utmost value to insurance practitioners as a whole. That status and influence would have been still greater if some Panel Committees had not withheld their support. Troublous times are in store for insurance practitioners, as anyone can see who considers the present economic condition of the country and the avowed intention of the Government to reduce expenditure all round in the coming year. This is no time for "swopping horses."

(E) The Insurance Acts Committee with confidence asks the Panel Committees of the country to decline the invitation of the Association of Panel Committees, and also to invite the Panel Committees forming that body, after the repeated evidence they have had of the intention of Panel Committees generally to support the Insurance Acts Committee, to fall into line with the majority. Their acceptance of the situation would be cordially welcomed and their co-operation would be an accession of strength, not merely to the Insurance Acts Committee, but to the whole of the organized insurance practitioners of the country. Their present attitude is bad for all parties concerned—except sometimes for those with whom we have to negotiate.

Finally, the Insurance Acts Committee sincerely hopes that this effort of the Association of Panel Committees may be the means of eliciting an expression of opinion which will convince that body first that it is on the wrong tack, and secondly that, if it is anxious (as the Insurance Acts Committee believes it is) to work for the better organization of Panel Committees, it will do well to throw in its lot with the majority and do its best to improve, from the inside, any defects it may find in the procedure or policy of the Conference of Local Medical and Panel Committees and its duly authorized central negotiating body the Insurance Acts Committee.

429, Strand, W.C.2.
June 2nd, 1921.

Naval and Military Appointments.

ROYAL NAVAL MEDICAL SERVICE.

THE following appointments are announced by the Admiralty:— Surgeon Commanders: A. J. Wernet to the *Pembroke*, additional, F. A. Robinson to the *Vivid* for H.M. Dockyard.

ROYAL NAVAL VOLUNTEER RESERVE.

Surgeon Lieut. Commander J. B. Ronaldson to the *Royal Oak*, additional.

ARMY MEDICAL SERVICE.
ROYAL ARMY MEDICAL CORPS.

Major W. W. Browne, O.B.E., relinquishes the acting rank of Lieut.-Colonel.

Captain A. Rodd is placed on the half-pay list on account of ill health. Temporary Captain G. J. McForty, M.C., to be Captain, with seniority October 19th, 1919 (substituted for notification in the *London Gazette* of April 26th, 1921).

Captain G. W. Rose, from S.R., to be Captain, with seniority October 10th, 1918, and precedence next below R. B. Myles.

The following officers relinquish their commissions: Temporary Major J. F. O'Malley and retains the rank of Major. Temporary Captains and retain the rank of Captain: D. L. Lindsay, R. J. Snider, R. A. Shekleton.

To be temporary Lieutenants: D. Loughridge, W. B. Fox.

INDIAN MEDICAL SERVICE.

Colonel J. K. Close, Inspector-General of Civil Hospitals, United Provinces, has been granted combined leave for six months, with effect from April 12th, or the subsequent date on which he may avail himself.

Lieut.-Colonel R. G. Turner, C.M.G., D.S.O., has been appointed to officiate as Inspector-General of Civil Hospitals, United Provinces.

* See SUPPLEMENT, March 9th, 1918, p. 29.

Lieut.-Colonel W. Young has been appointed to be Inspector-General of Civil Hospitals, Central Provinces (April 20d).

Lieut.-Colonel E. V. Hugo, C.M.G., Professor of Surgery, King Edward Medical College, Lahore, has been granted combined leave for twelve months (April 4th).

Major H. B. Broome, Professor of Anatomy, King Edward Medical College, Lahore, has been appointed to officiate as Professor of Surgery in that College.

Captain P. B. Bharucha, I.S.O., O.B.E., has been appointed to officiate as Professor of Anatomy, King Edward Medical College, Lahore.

The following officers have been reappointed to the Personal Staff of His Excellency the Viceroy and Governor-General:—To be honorary Surgeons: Lieut.-Colonel E. V. Hugo, C.M.G., Major A. E. J. Lister, Lieut.-Colonel B. R. Chatterton, Lieut.-Colonel R. McCarrison, Lieut.-Colonel D. W. Sutherland, C.I.E.

Major F. Stevenson has been posted as Civil Surgeon, Hazara (April 1st).

Lieut.-Colonel A. W. T. Buist, M.D., has been permitted to retire from the service (February 1st).

SPECIAL RESERVE OF OFFICERS.

ROYAL ARMY MEDICAL CORPS.

The following officers relinquish their commissions: Captain O. Williams, and is granted the rank of Major. Captains J. A. Musgrave and D. B. Robertson, and retain the rank of Captain.

TERRITORIAL FORCE.

ROYAL ARMY MEDICAL CORPS.

To be Majors: Captain G. T. Willan, D.S.O., February 16th, 1920 substituted for notice in the *London Gazette* of February 11th, 1921, Captain C. T. Corfield, S. E. Rigg, G. Potts.

To be Captains:—Captains: E. S. Stork, D.S.O., from T.F. Res., with precedence as from April 1st, 1915, next below Captain J. A. Stephens; David Stewart (late R.A.M.C.S.R.), with precedence as from August 5th, 1917; A. G. Williams (late R.N.V.R.), with precedence as from September 4th, 1918.

D. M. Lindsay to be Lieutenant.

TERRITORIAL FORCE RESERVE.

ROYAL ARMY MEDICAL CORPS.

The following officers, having attained the age limit, are retired: Major W. G. Willoughby, and retains the rank of Major, with permission to wear the prescribed uniform. Captain S. Hodgson, and retains the rank of Captain.

DEFENCE FORCE.

ARMY MEDICAL SERVICE.

To be Assistant Directors of Medical Services:—Temporary Colonels: A. D. Sharp, C.B., C.M.G., T.D., and F. H. Westmacott, C.B.E., T.D.

To be temporary Captains: W. J. Harrison, J. E. B. Coleman, J. F. Weston, T. B. Batchelor (substituted for notification in *London Gazette*, May 25th, 1921, appointing this officer as temporary Major).

1st (South Midland) Field Ambulance (D.F.).—To be temporary Captains: C. W. J. Brasher, J. H. Sheldon.

DIARY OF SOCIETIES AND LECTURES.

ROYAL COLLEGE OF PHYSICIANS, Pall Mall East, S.W.—Tues. and Thurs., 5 p.m., Croonian Lectures by Dr. F. L. Golla: The Objective Study of Neurosis.

ROYAL SOCIETY OF MEDICINE.—General meeting of Fellows, Thurs., 8.30 p.m. Discussion: The Problem of the Private Clinic System in Great Britain. To be opened by Sir Thomas Horder, followed by Dr. G. C. Anderson, Mr. Clayton-Greene, Mr. W. S. Dickie, Mr. Bishop Harman, Dr. A. F. Hurst, Dr. Drury Pennington, Sir Humphry Rolleston, Dr. Gilbert Scott, and Dr. Maurice Wright, *Section of Dermatology*: Thurs., 4.30 p.m., Cases.

ROYAL SOCIETY OF TROPICAL MEDICINE AND HYGIENE, 11, Chandos Street, W.1.—Fri., 7.45 p.m., Demonstration; 8.15 p.m., Annual General Meeting, to be followed by a paper by Major R. Koozles: The Mechanism and Treatment of Snake-bite in India.

WEST LONDON MEDICO-CHIRURGICAL SOCIETY, Kensington Town Hall.—Fri., 8 p.m., Cavendish Lecture by the Right Hon. Dr. C. Addison, M.P.: The Part of the State in the Prevention of Disease.

POST-GRADUATE COURSES AND LECTURES.

HOSPITAL FOR SICK CHILDREN, Great Ormond Street, W.C.—Thurs., 4 p.m., Dr. Thursfield: Moulds.

INSTITUTE OF PATHOLOGY AND RESEARCH, St. Mary's Hospital, Paddington, W.—Thurs., 4.30 p.m., Professor W. Bulloch, F.R.S.: Use and Abuse of Scientific Medical Literature.

LONDON HOSPITAL MEDICAL COLLEGE, E.—Mon., 5 p.m., Dr. W. M. Feldman: Ante-natal and Post-natal Child Physiology. Tues. and Fri., 5.15 p.m., Dr. M. Culpin: Psycho-neuroses. *Surgical Unit*, Mr. R. Warren, Tues., 4.15 p.m., Ventral Hernia; Wed., 4.15 p.m., Suppuration of the Lung.

MANCHESTER ROYAL INFIRMARY.—Tues., 4.30 p.m., Dr. E. B. Leech: Blood Pressure.

NATIONAL HOSPITAL FOR THE PARALYSED AND EPILEPTIC, Queen Square, W.C.—Mon., Tues., Thurs., Fri., 2 p.m.: Out-patient Clinics. Mon., 3.30 p.m., Dr. A. Turner: Demonstration of Cases. Lectures: 3.30 p.m., Tues., Mr. Armour: Surgical Treatment of Spinal Cord Tumours; Wed., Mr. L. Paton: Papilloedema; Thurs., Dr. F. Buzzard: Poliomyelitis.

NORTH-EAST LONDON POST-GRADUATE COLLEGE, Prince of Wales's General Hospital, Tottenham, N.15.—Daily, 2 p.m., In- and Out-patient Clinics, Operations, etc. *Lecture-Demonstrations*: 3 p.m., Tues., Mr. C. H. Hayton: Anatomy of the Nose and Accessory Sinuses; Wed., Mr. W. E. Tanner: Clinical Pathology and Differential Diagnosis of Scrotal Enlargements; Fri., Mr. T. H. C. Benians: Blood Examination in Diagnosis.

QUEEN'S HOSPITAL FOR CHILDREN, Hackney Road, E.—Mon., 4 p.m., Mr. W. P. T. Atkinson: Tinau Tonsillitis and its Treatment by X Rays. Tues., 4 p.m., Dr. S. A. Owen: The Premature Baby. Thurs., 12 noon, Mr. V. Nestle'd: Treatment of Corneal Ulcers by Subconjunctival Injection of Phenolaine Solution. Fri., 3.30 p.m., Dr. J. L. Bunch: Skin Diseases in Children.

WEST LONDON POST-GRADUATE COLLEGE, Hammersmith, W.—Daily, 10 a.m., Ward Visits; 2 p.m., In- and Out-patient Clinics and Operations. Lectures: Mon., 4.15 p.m., Dr. A. Saunders: Gastric Disorders in Old Age; Tues., Dr. H. Pritchard: Chronic Infective Processes; Thurs., 5 p.m., Dr. Harry Campbell: Observations on Diet; Fri., Mr. Baldwin: Surgery of the Rectum.

British Medical Association.

OFFICES AND LIBRARY, 429, STRAND, LONDON, W.C.2.

Reference and Lending Library.

THE READING ROOM, in which books of reference, periodicals, and standard works can be consulted, is open to members from 10 a.m. to 6.30 p.m., Saturdays 10 to 2.

LENDING LIBRARY: Members are entitled to borrow books, including current medical works; they will be forwarded, if desired, on application to the Librarian, accompanied by 1s. for each volume for postage and packing.

Departments.

SUBSCRIPTIONS AND ADVERTISEMENTS (Financial Secretary and Business Manager, Telegrams: Articulate, Westrand, London). MEDICAL SECRETARY (Telegrams: Mediseera, Westrand, London). EDITOR, *British Medical Journal* (Telegrams: Aitiology, Westrand, London).

Telephone number for all Departments: Gerrard 2630 (3 lines).

SCOTTISH MEDICAL SECRETARY: 6, Rutland Square, Edinburgh. (Telegrams: Associate, Edinburgh. Tel.: 4361 Central.)

IRISH MEDICAL SECRETARY: 16, South Frederick Street, Dublin. (Telegrams: Bacillus, Dublin. Tel.: 4737 Dublin.)

Diary of the Association.

JUNE.

- 14 Tues. Hastings Division, Eversfield Hotel, Hastings, 4.30 p.m.
Isle of Ely Division: Address by the Medical Secretary.
15 Wed. South-Western Branch Annual Meeting, White Hart Hotel, St. Austell, 3.15 p.m.; Luncheon, 1 p.m. to 2.15 p.m.; Annual Dinner, 7.45 p.m.
16 Thurs. Central Division, Birmingham Branch, Annual Meeting, 18, Bennett's Hill, 3.45 p.m.
Hampstead Division, Annual Meeting, Hampstead General Hospital, Haverstock Hill, 5 p.m.
17 Fri. London: Standing Subcommittee, Central Ethical Committee, 2 p.m.
Sheffield Division, Church House, St. James Street, Sheffield, 8.30 p.m.
22 Wed. London: **Council.**
23 Thur. South Wales and Monmouthshire Branch: Annual meeting, Council Chamber, Barry, 3.30 p.m.
24 Fri. Metropolitan Counties Branch Annual Meeting, 429, Strand, W.C.2, 4 p.m.
29 Wed. London: Propaganda Subcommittee, 2.15 p.m.
Oxford and Reading Branch Annual Meeting, Town Hall, Maidenhead.
30 Thnr. Worcestershire and Herefordshire Branch: Annual Meeting, The Infirmary, Worcester, 3 p.m.

JULY.

- 1 Fri. Cambridge and Huntingdon Branch, Annual Meeting, Harlech House, Burwell, 12.30 p.m. Luncheon, 1.30 p.m. Presidential Address, 2.45 p.m.
8 Fri. Surrey Branch Annual Meeting, Guildford.
15 Fri. East Yorks and North Lincoln Branch, Annual Meeting, Grimsby.

APPOINTMENTS.

BRANSGROVE, W. S. V., M.B., Ch.B., New Zealand, Senior House-Surgeon, Royal Ear Hospital (Ear, Nose, and Throat Department, University College Hospital).

BROWN, A. Middleton, M.A., M.D. Aberd., D.P.H., Medical Officer of Health and School Medical Officer, City of Chester.

NATTRASS, Frederick J., M.D. Durh., M.R.C.P. Lond., Honorary Assistant Physician to the Royal Victoria Infirmary, Newcastle-upon-Tyne.

JESSOP HOSPITAL FOR WOMEN, SHEFFIELD.—Senior Resident Officer: R. J. B. Hall, M.B., Ch.B. Otago; Assistant House-Surgeons: C. H. Jaede, M.B., Ch.M. Syd., and G. J. Sophianopoulos, M.R.C.P., M.B.C.S.

BIRTHS, MARRIAGES, AND DEATHS.

The charge for inserting announcements of Births, Marriages, and Deaths is 9s., which sum should be forwarded with the notice not later than the first post on Tuesday morning, in order to ensure insertion in the current issue.

BIRTHS.

FENN.—On June 5th, in a nursing home, Sheffield, to Beatriz, wife of Robert M. Fenn, M.B., C.M., etc.—a son (23, Ladysmith Avenue, Sheffield).

HERINGTON.—On May 29th, at Spratslade Drive, Longton, Staffs, the wife of Cecil Herington, M.B., B.S. Lond., M.R.C.S., L.R.C.P.—of a son.

MALLAM.—On June 2nd, at Lyndale, London Road, Redhill, the wife of Dalton Mallam, M.R.C.S., L.R.C.P.—of a son.

ROBERTS.—On June 1st, at 104, Midland Road, Bedford, to Dr. and Mrs. E. Cleaton Roberts—a son.

DEATH.

BIGGS.—May 29th, at 101, Northcote Road, Elizabeth, wife of M. G. Biggs, M.D.

SUPPLEMENT

TO THE

BRITISH MEDICAL JOURNAL.

LONDON: SATURDAY, JUNE 18TH, 1921.

CONTENTS.

	PAGE		PAGE
BRITISH MEDICAL ASSOCIATION.		ANNUAL DINNER OF THE ASSOCIATION: Form of	
CURRENT NOTES:		Notification of Attendance	231
THE ANNUAL MEETING AT NEWCASTLE	229	ASSOCIATION NOTICES:	
THE SECTION OF MEDICAL SOCIOLOGY	229	MEETING OF COUNCIL	230
THE ANNUAL EXHIBITION	229	SCHOLARSHIPS AND GRANTS IN AID OF SCIENTIFIC RESEARCH	230
THE TEMPERANCE BREAKFAST	229	NOTICES OF MOTION FOR REPRESENTATIVE MEETING	230
DAINGEROUS DRUGS REGULATIONS	229	BRANCH AND DIVISION MEETINGS TO BE HELD	230
THE NEW POSTAL RATES	229	APPOINTMENTS...	
PAYMENT OF TRAVELLING EXPENSES IN CONNEXION WITH		DIARY OF SOCIETIES AND LECTURES	232
INQUESTS	229	ASSOCIATION INTELLIGENCE AND DIARY	232
THE MACDONALD PRESENTATION	230	BIRTHS, MARRIAGES, AND DEATHS	232
COUNCIL ELECTION	230		

British Medical Association.

CURRENT NOTES.

THE ANNUAL MEETING AT NEWCASTLE.

The programme of the Annual Meeting was printed in the Supplement of June 4th, and a form for notification of attendance appeared on page 217 of that issue. The Annual Representative Meeting will begin on Friday, July 15th, at 10 a.m., and be continued on the following days. The Representatives' Dinner will be held on Friday, July 15th, at 7.30 p.m. The statutory Annual General Meeting will be held on July 19th, at 2 p.m., and the Adjourned General Meeting at 8 p.m., when the new President, Professor David Drummond, will give his address. The Annual Dinner of the Association will take place on Thursday, July 21st, at 7.30 p.m.; members wishing to attend are requested to fill up the form on page 231 and forward it to the Local General Secretary. Religious services will be held on Tuesday, July 19th, at 5 p.m. The Conference of Secretaries will be held at 2 p.m. on Wednesday, July 20th, and the Secretaries' Dinner will take place in the evening at 6.30. A Special Address on "Industrial Hygiene: its Rise, Progress and Opportunities," will be given by Sir Thomas Oliver, LL.D., M.D., F.R.C.P., on Wednesday, July 20th, at 8 p.m. The Popular Lecture, on "Evolutionary Wounds," will be delivered by Sir Arthur Keith, M.D., F.R.S., on Friday, July 22nd, at 7.30 p.m.

The Section of Medical Sociology.

The Section of Medical Sociology will meet in the King's Hall, Armstrong College, at 10 a.m. on Friday, July 22nd. The discussion on "The relation of the medical profession to rate-provided hospitals and clinics," will be opened by Sir George Newman, Chief Medical Officer of the Ministry of Health, by Mr. David Adams, of Newcastle, and by Dr. Middleton Martin, Medical Officer of Health for Gloucestershire. Several other speakers have provisionally promised to take part in the discussion. The chair will be taken by Sir Jenner Verrall, LL.D., M.R.C.S. The meeting is open to the general public, and it is hoped that all interested will attend.

The Annual Exhibition.

The Annual Exhibition of Surgical Instruments, Drugs, Foods, etc., in connexion with the annual meeting of the British Medical Association will be held this year in the St. George's Drill Hall, St. Mary's Place, Newcastle-upon-Tyne. Arrangements for the exhibition are now practically complete, and there will be a large and representative display of the latest inventions and improvements in surgical instruments, appliances, etc., and of developments in medicinal and dietetic preparations. The hall lends itself admirably for the purpose of this exhibition, for it has an area of over 17,000 square feet on one floor. It is situated within a minute's walk of the College of

Medicine, where the Reception Room will be arranged; members will thus be afforded a good opportunity of inspecting the exhibits. Luncheons, afternoon teas, etc., will be provided in the Exhibition, and a first class orchestra will play daily.

The Temperance Breakfast.

Professor David Drummond, C.B.E., M.D., President-elect of the British Medical Association, and Vice-Chancellor of the University of Durham, will preside over the fifty-first annual medical breakfast arranged by the National Temperance League. The breakfast will be held on the morning of Thursday, July 21st, at Newcastle-upon-Tyne, and Sir Alfred Pearce Gould, K.C.V.O., F.R.C.S., will deliver a special address.

Dangerous Drugs Regulations.

The Dangerous Drugs Regulations,¹ as amended by the Committee which was appointed for that purpose, have been considered by the Medico-Political Committee of the British Medical Association. The Medico-Political Committee has advised the Council that, seeing that most of the Association's objections to the original draft Regulations have been met, there is no reason to offer any further opposition, though the Committee is still of opinion that with one or two exceptions the Regulations will be of little or no use in suppressing drug abuse. The revised Dangerous Drugs Regulations will come into force on September 1st, 1921, and we hope to publish at an early date a statement showing exactly how the Regulations will affect both medical practitioners who dispense their own medicines and those who do not.

The New Postal Rates.

It was stated in this column last week that the Journal Committee had considered the effect upon the Association's expenditure of the proposed increase in postal rates for printed matter sent abroad, and that the British Medical Association was joining with other newspaper proprietors in making representations to the Postmaster-General. It is satisfactory to be able to record that the Postmaster-General has now abandoned the increase in the foreign postage rates for printed papers, which would have involved the Association in an additional payment of more than £2,250 a year.

Payment of Travelling Expenses in Connexion with Inquests.

In February last the British Medical Association sent a circular letter to all county councils asking them to pay travelling allowances to medical practitioners called upon to attend inquests. This action was taken because it was understood that the Montgomery County Council was paying such allowances, and it appeared only reasonable that other county councils should do the same. A number

¹ See SUPPLEMENT, June 4th, 1921, p. 230.

of replies have been received to the circular, and from these it appears that there is a considerable difference of opinion as to what can and what cannot be done under the Coroners Act. Some county councils were unaware of any legal authority under which they could pay, and feared they might be surcharged if they paid. On the other hand, several county councils, including East Sussex, Kent, Northants, Hants, Westmorland, and the West Riding of Yorkshire, reported that they have paid for a number of years, apparently without any question being raised as to the legality of their action. Lancashire, as a result of the Association's letter, has decided to pay in future.

It appears that action can be taken under Section 25 of the Coroners Act of 1887, which states:

The local authority for a county or borough from time to time may make, and when made may alter and vary a schedule of fees, allowances, and disbursements which on the holding of an inquest may lawfully be paid and made by the coroner holding such inquest (other than the fees payable to medical witnesses in pursuance of this Act), and the local authority shall cause a copy of every such schedule to be deposited with the clerk of the peace of the county or with the town clerk of the borough, and one other copy thereof to be delivered to every coroner concerned.

Mileage, when allowed, varies considerably. Sometimes the actual sum disbursed is allowed, sometimes a first class return fare is given, and in other cases mileage is paid which varies from 3d. to 9d. a mile. In view of the information which has been obtained by the issue of this circular, those Divisions in whose area no fees are paid are being asked to approach their county councils with a view to inducing them to pay travelling expenses.

The Macdonald Presentation.

The Macdonald Presentation Fund will be closed at the end of the present month. The intention is to make the presentation to Dr. J. A. Macdonald during the forthcoming Annual Meeting of the Association at Newcastle-on-Tyne. Subscriptions of any amount not exceeding five guineas, and made payable to "The Macdonald Presentation," should be sent to the Medical Secretary, 429, Strand, W.C.2, not later than June 30th.

Council Election.

The detailed result of the voting in the four Groups of Branches where a contest took place was published in last week's SUPPLEMENT at page 222. The names of the members already declared elected to the Council for 1921-22 in the eight groups where there was no contest were printed in the SUPPLEMENTS of May 21st (p. 192) and May 28th (p. 197).

Association Notices.

MEETING OF COUNCIL.

THE next meeting of Council will be held on Wednesday, June 22nd, in the Council Room, 429, Strand, London, W.C.2, at 10 a.m.

REPRESENTATIVE MEETING.

DATE.

THE Annual Representative Meeting at Newcastle will begin on Friday, July 15th, 1921, at 10 a.m.

NOTICES OF MOTION AND AMENDMENT BY DIVISIONS AND BRANCHES.

The Supplementary Report of Council to the Representative Meeting will appear in the SUPPLEMENT of July 2nd, 1921.

Notices of Motion and Amendment by Divisions and Branches for consideration by the Annual Representative Meeting will be published in the SUPPLEMENT as they are received, but none can be published later than July 2nd, for which purpose they must be received by the Medical Secretary not later than the first post on Monday, June 27th.

It will be possible, however, to include in the Agenda for the Annual Representative Meeting all Notices of Motion and Amendment which are received by the Medical Secretary *not later than the first post on Monday, July 4th, 1921.*

SCHOLARSHIPS AND GRANTS IN AID OF SCIENTIFIC RESEARCH.

SCHOLARSHIPS.

THE Council of the British Medical Association is prepared to receive applications for Research Scholarships as follows:

1. AN ERNEST HART MEMORIAL SCHOLARSHIP, of the value of £200 per annum, for the study of some subject in the department of State Medicine.
2. THREE RESEARCH SCHOLARSHIPS, each of the value of £150 per annum, for research into some subject relating to the Causation, Prevention, or Treatment of Disease.

Each scholarship is tenable for one year, commencing on October 1st, 1921. A Scholar may be reappointed for not more than two additional terms.

The Conditions of the award of Scholarships are stated in the Regulations, a copy of which will be supplied on application to the Medical Secretary of the Association, 429, Strand, London, W.C.2.

GRANTS.

The Council of the British Medical Association is also prepared to receive applications for Grants for the assistance of Research into the Causation, Treatment, or Prevention of Disease. Preference will be given, other things being equal, to members of the medical profession, and to applicants who propose as subjects of investigation problems directly related to practical medicine.

The Conditions of the award of Grants are stated in the Regulations, a copy of which will be supplied on application to the Medical Secretary of the Association, 429, Strand, London, W.C.2.

Applications.

Applications for Scholarships and Grants for the year 1921-22 must be made not later than Saturday, June 25th, 1921, in the prescribed form, a copy of which will be supplied by the Medical Secretary on application.

Each application should be accompanied by testimonials, including a recommendation from the head of the laboratory, if any, in which the applicant proposes to work, setting out the fitness of the candidate to conduct such work, and the probable value of the work to be undertaken. This is not intended, however, to prevent applications for Grants in aid of work which need not be performed in a recognized laboratory.

NOTICES OF MOTION BY DIVISIONS FOR THE ANNUAL REPRESENTATIVE MEETING, NEWCASTLE, 1921.

BY BRISTOL DIVISION:

Roll Call: Card Vote.

That the recommendation contained in para. 82 of the Annual Report of Council (SUPPLEMENT, April 30th, 1921, p. 114) be amended by the substitution of "by not less than thirty" for "by a majority" in the last line but one.

Payment of Practitioners for Services Rendered to Paying Patients in Hospitals.

That the seventh recommendation contained in para. 251 of the Annual Report of Council (SUPPLEMENT, April 30th, 1921, p. 133) be amended by the substitution of "subject to a maximum fee to be fixed by the committee of the hospital in consultation with the staff" for "as at present" in the fifth and sixth lines.

Formation of Medical Staff Fund.

That the eighth recommendation contained in para. 251 of the Annual Report of Council (SUPPLEMENT, April 30th, 1921, p. 133) be amended by the insertion of "at the request of the staff" after "passed" in the eighth line.

BRANCH AND DIVISION MEETINGS TO BE HELD.

CAMBRIDGE AND HUNTINGDON BRANCH.—The seventy-seventh annual meeting of the Branch will be held at Harlech House, Burwell, on Friday, July 1st, at 12.30 p.m., when the financial statement for the past year will be presented and the officers for 1921-22 elected. Luncheon, by the kind invitation of the president-elect, Mr. O. R. Ennion, will be served in the Gardner Memorial Hall at 1.30 p.m. At 2.45 p.m. Mr. Ennion will deliver his presidential address, entitled "With the field ambulance at Gallipoli." At 4 p.m. Mr. and Mrs. Ennion will be "At home" at Harlech House.

EAST YORKS AND NORTH LINCOLN BRANCH. The sixty-fifth annual meeting of the above Branch will be held at Grimsby on Friday, July 15th. The place and hour of meeting will be announced later. Business: Election of officers and presidential address. Nominations must be in the hands of the honorary secretary before July 1st.

EDINBURGH BRANCH.—The annual meeting of the Edinburgh Branch will be held in the Hall of the Royal College of Physicians, 9, Queen Street, Edinburgh, on Thursday, June 30th, at 4 p.m. Tea will be served at 3.45. Business: Report of Branch Council. Annual Reports of Branch and of Divisions. Treasurer's Financial Statement. Election of office-bearers for 1921-22. Report of Election of Representative for 1921-22 to the Council of the Association for the Edinburgh and Fife Branches. Election to annual vacancy on the Board of Management of the Queen Mary Nursing Home. Proceedings of Scottish Committee. Correspondence from Medical Secretary. Annual Report of Council and Annual Representative Meeting. Any other competent business.

LANCASHIRE AND CHESHIRE BRANCH.—The eighty-fifth annual meeting of the Branch will be held in the Lecture Theatre of the Grosvenor Museum, Chester, on Thursday, June 23rd. Luncheon will be served at 1 p.m. at the Freemasons' Hall, Hunter Street (Northgate Street); 2.15 p.m., Branch Council meeting; 2.30 p.m., Annual Meeting. Agenda: Report of Branch Council and Financial Statement. Presidential Address by Dr. John Elliott, O.B.E.: "The Hospital, its past, present, and future, especially with reference to the provision of medical services." Election of Officers, and other business. 3.30 p.m., Visits and Excursions. 5.30 to 6.30 p.m., Tea.

METROPOLITAN COUNTIES BRANCH.—The annual general meeting of the Metropolitan Counties Branch will be held at 429, Strand, W.C., on Friday, June 24th, at 4 p.m. Business: (1) Report of scrutineers as to the election of new officers. (2) Annual Report of Council. (3) Alteration in Rule 11 by the insertion of words providing that such members of the Branch as are members of the Central Council shall be *ex officio* members of the Metropolitan Counties Branch Council. (4) President's address by Dr. H. B. Brackenbury, on "The Psychologist in Public Life."

METROPOLITAN COUNTIES BRANCH: WILLESDEN DIVISION.—A meeting of members and non-members will be held on Tuesday, June 21st, at 8.30 p.m., at St. Andrew's Parish Hall (Institute behind Church, High Road, Willesden Green, N.W.). Mr. W. MacAdam Eccles, F.R.C.S., will explain the draft of suggested organization for London—the National Provident Scheme for Hospital and Additional Medical Services (see SUPPLEMENT, April 30th). Instructions will be given to the Representative. Annual Representative Meeting. A report will be presented on the Practitioners' Mutual Help Scheme.

NORTH LANCASHIRE AND SOUTH WESTMORLAND BRANCH.—The annual meeting will be held at 3 p.m. on Wednesday, June 29th, at the Corporation Hotel, Lancaster (near Royal Lancaster Infirmary). Business: Minutes. Annual Report.

Financial Report. Election of office-bearers. A Ray Demonstration. Pathological Exhibits. The President, Dr. A. S. Barling, invites members to tea at the hotel.

OXFORD AND READING BRANCH. The annual meeting of the Branch will be held at Maidenhead on Wednesday, July 6th, at the Town Hall at 5.30 p.m. Any members wishing to show cases or read notes should communicate at once with Dr. E. W. Squire, 225, King's Road, Reading. Dinner will be arranged afterwards at one of the riverside hotels. Those intending to be present and having room in their cars or requiring a lift are asked to write to the secretary.

SOUTH WALES AND MONMOUTHSHIRE BRANCH. The annual meeting of the South Wales and Monmouthshire Branch will be held at the Council Chamber, Barry, Glamorganshire, on Thursday, June 23rd, at 3.30 p.m.

SURREY BRANCH. The annual meeting of the Surrey Branch will be held at Guildford on Friday, July 8th.

SURREY BRANCH: CROYDON DIVISION.—A general meeting of the Croydon Division will be held at the Croydon General Hospital on Wednesday, June 22nd, at 4 p.m. Agenda: Correspondence. Suggestions regarding Post-graduate Course. Report of Council and instructions to Representative. Any other business. Members are requested to bring SUPPLEMENTS of BRITISH MEDICAL JOURNAL for March 5th, April 30th, and May 14th.

SURREY BRANCH: GUILDFORD DIVISION.—A clinical meeting of the Guildford Division will be held at the Royal Surrey County Hospital, Guildford, on Thursday, June 23rd, at 4.15 p.m. Mr. S. Mwyn Smith, O.B.E., D.S.O., F.R.C.S. Ed., will give a practical demonstration of the treatment of fractures. All interested are referred to the lecture in the BRITISH MEDICAL JOURNAL, April 2nd, 1921. Tea will be served at 4.15 p.m.

WORCESTERSHIRE AND HEREFORDSHIRE BRANCH.—The annual meeting of the Worcestershire and Herefordshire Branch will be held at the Infirmary, Worcester, on June 30th, at 3 p.m.

MALAYA BRANCH.—Meetings of the Malaya Branch are held in Singapore on the third Thursday of each month. Members desiring to contribute papers are requested to communicate with the honorary secretary, Dr. J. W. Scharrif, care of Port Health Office, Singapore. Arrangements can be made for the exhibition of specimens or cases of interest brought to the meetings.

APPOINTMENTS.

BROWN, A. Middleton, M.A., M.D. Aberd., D.P.H., Medical Officer of Health and School Medical Officer, City of Hereford, and not Chester, as printed last week.

REID, A. Christie, D.O. Oxon., Honorary Surgeon to the Nottingham Eye Infirmary, vice Colonel H. Herbert (resigned).

WARBURTON, G. B., Ch.M., F.R.C.S., Visiting Surgeon to the Crumpsall Institution and Infirmary, Manchester.

British Medical Association.

EIGHTY-NINTH ANNUAL MEETING, NEWCASTLE-UPON-TYNE, JULY, 1921.

ANNUAL DINNER.

The Annual Dinner of the Association will be held in the GRAND ASSEMBLY ROOMS, College Road, Newcastle-upon-Tyne, on THURSDAY, July 21st, at 7.15 p.m. Tickets, 20s. each, may be had now from the Local General Secretary, 6, Kensington Terrace, Newcastle-upon-Tyne. The price of the ticket to be remitted with all applications, preferably by Postal Order. Members wishing to sit together will have an opportunity of arranging to do so later, and due notice of the seating arrangements will be given.

As the number of Tickets is limited, early application should be made. They will be allotted in the order of application.

Please reserve a seat for me at the Dinner, for which I enclose a remittance of 20s.

Signature _____

Address _____

DIARY OF SOCIETIES AND LECTURES.

LONDON DERMATOLOGICAL SOCIETY, 49, Leicester Square, W.C.—
Tues., 4.30 p.m., Annual General Meeting, 5 p.m., Address by
Dr. T. M. Legge, C.B.E.: Occupational Dermatoses and the State.
ROYAL COLLEGE OF PHYSICIANS, Pall Mall East, S.W.—Tues., 5 p.m.,
(Croonian Lecture by Dr. F. L. Golla: The Objective Study of
Neurosis.

POST-GRADUATE COURSES AND LECTURES.

HOSPITAL FOR SICK CHILDREN, Great Ormond Street, W.C.—
Thurs., 4 p.m., Mr. T. Gray: Hare-lip and Cleft Palate.

LONDON HOSPITAL MEDICAL COLLEGE.—Mon., 5 p.m., Dr. W. M.
Feldman: Ante natal and Post-natal Child Physiology. *Surgical
Unit*: Mr. R. Milne, Tues., 4.15 p.m., Non-tuberculous Hip Dis-
ease; Thurs., 4.15 p.m., Endosteal Tumours of the Bones.

NATIONAL HOSPITAL FOR THE PARALYSED AND EPILEPTIC, Queen
Square, W.C.—Mon., Tues., Thurs., and Fri., 2 p.m.: Out-patient
Clinics. *Demonstrations of Cases*: 3.30 p.m., Mon., Dr. A. Turner;
Tues., Dr. R. Russell; Fri., Dr. Collier. *Lectures*: 3.30 p.m.,
Wed., Mr. J. Paton: Papilloedema. Thurs., Dr. F. Buzzard:
Poliomyelitis.

NORTH-EAST LONDON POST-GRADUATE COLLEGE, Prince of Wales's
General Hospital, Tottenham, N.15.—Daily, 2 p.m., In- and Out-
patient Clinics, Operations, etc. *Lecture Demonstrations*: 3 p.m.,
Tues., Mr. C. H. Hayton: Diseases of the Nasal Cavities and
Accessory Sinuses and their Treatment; Wed., Mr. W. E. Tanner:
Pathology and Diagnosis of Scrotal Enlargements (2); Fri., Mr.
T. H. C. Benians: Blood Examination in Diagnosis (2).

QUEEN'S HOSPITAL FOR CHILDREN, Hackney Road, E.—Tues., 4 p.m.,
Dr. C. L. Hewer: Anaesthesia in Children. Thurs., 4 p.m., Dr.
B. W. Howell: Demonstration of Cases and Plasters. Fri., 5 p.m.,
Dr. C. Alice King: Rheumatism in Children.

WEST LONDON POST-GRADUATE COLLEGE, Hammersmith, W.—
Daily, 10 a.m., Ward Visits; 2 p.m., In- and Out-patient Clinics
and Operations. *Lectures*, 5 p.m.:—Mon., Mr. Armour: Diseases
of the Gall Bladder and Ducts. Tues., Dr. Pernet: Some Bullous
Eruptions. Wed., Mr. Baldwin: Surgery of the Rectum. Thurs.,
Dr. J. C. Bridge: General Practitioners and the Prevention of
Industrial Diseases. Fri., Mr. T. Gray: Surgical Physiology of
the Alimentary Tract.

BIRTHS, MARRIAGES, AND DEATHS.

The charge for inserting announcements of Births, Marriages,
and Deaths is 9s., which sum should be forwarded with the
notice not later than the first post on Tuesday morning, in
order to ensure insertion in the current issue.

BIRTH.

HAIG FERGUSON.—At Ludd, Palestine, on 19th May, the wife of
William Haig Ferguson, M.C., B.A., M.B., Capt. R.A.M.C., of a
daughter (stillborn).

MARRIAGES.

RUTHERFORD—RESTON.—At North British Station Hotel, Glasgow,
on 8th June, 1921, by Rev. E. Sherwood Gunson, M.A., F.S.A.Scot.,
New Monkland Parish, William Rutherford, M.C., M.B.,
Ch.B., Glasg., son of A. Rutherford, 353, W. Princes Street,
Glasgow, to Bessie, younger daughter of G. M. Reston, The
Woodlands, Airdrie, N.B.

TRUMPER—TIRARD.—On June 11th, at All Saints, Margaret Street, W.,
William Arthur Trumper, M.R.C.S., L.R.C.P., of Ivybridge, South
Devon, to Marioid Tirard, elder daughter of Sir Nestor and Lady
Tirard, of 74, Harley Street, W.

British Medical Association.

OFFICES AND LIBRARY, 429, STRAND, LONDON, W.C.2.

Reference and Lending Library.

THE READING ROOM, in which books of reference, periodicals,
and standard works can be consulted, is open to members
from 10 a.m. to 6.30 p.m., Saturdays 10 to 2.

LENDING LIBRARY: Members are entitled to borrow books,
including current medical works; they will be forwarded,
if desired, on application to the Librarian, accompanied
by 1s. for each volume for postage and packing.

Departments.

SUBSCRIPTIONS AND ADVERTISEMENTS (Financial Secretary and
Business Manager, Telegrams: Articulate, Westrand, London).
MEDICAL SECRETARY (Telegrams: Medisecra, Westrand, London).
EDITOR, *British Medical Journal* (Telegrams: Aitiology, Westrand,
London).
Telephone number for all Departments: Gerrard 2630 (3 lines).

SCOTTISH MEDICAL SECRETARY: 6, Rutland Square, Edinburgh.
(Telegrams: Associate, Edinburgh. Tel.: 4361 Central.)
IRISH MEDICAL SECRETARY: 16, South Frederick Street, Dublin.
(Telegrams: Bacillus, Dublin. Tel.: 4737 Dublin.)

Diary of the Association.

JUNE.

- 17 Fri. London: Standing Ethical Subcommittee, 2 p.m.
Sheffield Division, Church House, St. James Street,
Sheffield, 8.30 p.m.
- 21 Tues. Willesden Division, St. Andrew's Parish Hall, High Road,
Wilkesden Green, N.W., 8.30 p.m.
- 22 Wed. London: **Council**, 10 a.m.
Croydon Division, Croydon General Hospital, 4 p.m.
- 23 Thur. Guildford Division, County Hospital, Guildford, 4.15 p.m.
Lancashire and Cheshire Branch, Annual Meeting, 2.30 p.m.,
Lecture Theatre, Grosvenor Museum, Chester. Luncheon
1 p.m.
South Wales and Monmouthshire Branch: Annual meeting,
Council Chamber, Barry, 3.30 p.m.
- 24 Fri. Metropolitan Counties Branch Annual Meeting, 429, Strand,
W.C.2, 4 p.m.
- 29 Wed. London: Propaganda Subcommittee, 2.15 p.m.
North Lancashire and South Westmorland Branch, Annual
Meeting, Corporation Hotel, Lancaster, 3 p.m.
- 30 Thur. Edinburgh Branch, Annual Meeting, Hall of the Royal
College of Physicians, 9, Queen Street, 4 p.m.
Worcestershire and Herefordshire Branch: Annual Meet-
ing, The Infirmary, Worcester, 3 p.m.

JULY.

- 1 Fri. London: Agenda Committee, 2.30 p.m.
Cambridge and Huntingdon Branch, Annual Meeting,
Harlech House, Burwell, 12.30 p.m. Luncheon, 1.30 p.m.
- 6 Wed. Oxford and Reading Branch Annual Meeting, Town Hall
Maidenhead, 3.30 p.m.
- 8 Fri. Surrey Branch Annual Meeting, Guildford.
- 15 Fri. East Yorks and North Lincoln Branch, Annual Meeting
Grimsby.

Stamp.

The Hon. Local GENERAL SECRETARY,
British Medical Association,
6, Kensington Terrace,
Newcastle-on-Tyne.

SUPPLEMENT

TO THE

BRITISH MEDICAL JOURNAL.

LONDON: SATURDAY, JUNE 25TH, 1921,

CONTENTS.

British Medical Association.		PAGE	ASSOCIATION NOTICES:		PAGE
CURRENT NOTES:			DATE OF REPRESENTATIVE MEETING 235		
THE MACDONALD PRESENTATION	233	INSURANCE:			
SECURITY OF TENURE FOR MEDICAL OFFICERS OF HEALTH... ..	233	LONDON PANEL COMMITTEE			235
FEES TO PRACTITIONERS CALLED IN BY MIDWIVES (SCOTLAND)	233	NAVAL AND MILITARY APPOINTMENTS... ..			235
RELIGIOUS SERVICES AT THE ANNUAL MEETING	233	ASSOCIATION INTELLIGENCE			236
THE BELGRADE UNIVERSITY LIBRARY	233	DIARY OF THE ASSOCIATION			236
A CORRECTION	233	DIARY OF SOCIETIES AND LECTURES			236
MEETINGS OF BRANCHES AND DIVISIONS	233	BIRTHS, MARRIAGES, AND DEATHS			236
MEETINGS TO BE HELD... ..	235				

British Medical Association.

CURRENT NOTES.

The Macdonald Presentation.

THE Macdonald Presentation Fund will be closed at the end of the present month. The intention is to make the presentation to Dr. J. A. Macdonald during the forthcoming Annual Meeting of the Association at Newcastle-upon-Tyne. Subscriptions of any amount not exceeding five guineas, and made payable to "The Macdonald Presentation," should be sent to the Medical Secretary, 429, Strand, W.C.2, not later than June 30th. The following additional subscriptions have been received:

	£	s. d.		£	s. d.
Brought forward	952	4 0	Dr. G. Thomson, Retford	2	2 0
Dr. W. Webster, Newcastle, Staffs	1	1 0	Dr. F. J. Gomez, West Hayes, Stn. Petherton	0	10 6
Dr. R. G. McGowan, Manchester	1	1 0	Dr. C. S. Miller, Nottingham	1	1 0
Dr. J. N. Marshall, Rothesay	1	1 0			
				959	0 6

Security of Tenure for Medical Officers of Health.

THE Public Health Officers Bill has now been introduced into the House of Lords. We learn from Sir Philip Magnus, who so skilfully piloted the bill through the House of Commons, that it will be taken charge of in the Upper House by Lords Gainford and Dawson. Several other members of the Upper House are being asked to give their support to the bill.

Fees to Practitioners Called in by Midwives (Scotland).

THE Scottish Committee, at its meeting on June 16th, considered a reply received from the Board of Health to the inquiry made respecting payment of fees for "subsequent necessary visits." The Board intimated that they were precluded by the Act from authorizing payment for more than one subsequent visit, but expressed their willingness to ask such local authorities as have maternity and infant welfare schemes to insert in the scheme a clause providing for the payment of a fee of 2s. 6d. per visit for subsequent necessary visits in cases where the fee for attendance at confinement and one subsequent visit is payable. The Committee decided that it could not accept such an offer, and asked the Board to promulgate the scale of fees as proposed, and as published in the SUPPLEMENT of May 14th, 1921, p. 185.

Religious Services at the Annual Meeting.

ARRANGEMENTS have now been completed for the religious service to be held at 5 p.m. on Tuesday, July 19th, in St. Nicholas Cathedral, Newcastle-upon-Tyne. The Lord Mayor, who will attend the service in state, has granted the use of the Concert Hall in the Town Hall for robing, and the procession, consisting of the Lord Mayor, the clergy, ministers of the Free Church Council, and the

officers and officials of the British Medical Association, will leave for the Cathedral at 4.55 o'clock. The address will be given by the Bishop of Newcastle, and the Rev. W. J. Jack, Secretary of the Newcastle Free Church Council, will read the lesson. By the co-operation of the organist the service will be fully choral. On the morning of the same day a Roman Catholic service will be held in St. Mary's Cathedral, Clayton Street; mass will be celebrated at 9.15 a.m.

The Belgrade University Library.

THE South Slav Entente Committee is nearing the end of its effort to endow Belgrade University with a large selection of English standard works, in which it has been assisted by the British Medical Association among others. The object is to repair in part the destruction of the university library and its equipment during the late war, and over 18,000 books have been sent in 150 crates to Belgrade. The very success of the committee's efforts has caused difficulty in the expense of transport, and although a sum of about £96 has been raised, £54 more is still needed, and the committee is appealing for funds to those who have not already contributed. Contributions may be sent either to Professor Sir Charles Oman, or to Mrs. J. D. Ellis, at the Royal Society of Literature, 2, Bloomsbury Square, W.C.1. A collection of spare medical and scientific works has already been forwarded to Serbia from the library of the British Medical Association, and the Journal Committee at its last meeting sanctioned the sending of a free copy of the BRITISH MEDICAL JOURNAL each week to the Belgrade University Library.

A Correction.

WE are asked to contradict a statement made in the annual report of the Lancashire and Cheshire Branch, which has been circulated among members of the Branch, to the effect that Dr. Walter Stansfield, Liscard, Birkenhead, was dead. The reference should have been to the late Dr. Walter Stansfield, Broughton Park, Manchester; the mistake was made in the information supplied to the Association by the General Medical Council.

Meetings of Branches and Divisions.

EAST YORK AND NORTH LINCOLN BRANCH: NORTH LINCOLN DIVISION.

Address by the Medical Secretary.

A MEETING of the North Lincoln Division was held at Grimsby on June 8th, and was addressed by the Medical Secretary, Dr. ALFRED COX, who expressed his pleasure at making his first visit to the Division, and proceeded to deal with the subject, "What use is the British Medical Association to the medical profession and the public?" The meeting was presided over by Dr. T. S. MORLEY (Barton-on-Humber), Vice-Chairman, in the unavoidable absence of the Chairman, Dr. Williamson. An invitation

to be present had been extended to all medical men practising in the area.

Dr. Cox said that the first part of the question would no doubt seem superfluous to those who had any idea of the work the British Medical Association was doing and its great influence with the authorities and the public; but the fact that some 40 per cent. of the profession remained outside the Association was a proof that the question needed to be answered. The pity was that those who criticized the Association most freely were always most prone to absent themselves on occasions like this. Recently a circular had been sent out from headquarters to non-members asking them to join the Association, or in the alternative to state why they would not, and he had been struck with the illogicality and triviality of most of the answers. Some showed that the correspondents had reasoned out their position, and even though one did not agree with their conclusions one was bound to respect those who took that trouble. But by far the greater number of answers gave one or more of the following three reasons for not joining: (1) Dissatisfaction with the action of the Association in connexion with the Insurance Acts; (2) the lowering of the fee for notification of infectious diseases; and (3) doubts as to whether the constitution of the Association gave it power to protect the interests of its members. As to the first, his answer was that whatever might be the opinion held as to the success or otherwise of the Association's action (and there were at least two opinions on that) it was ancient history. If it were agreed that the profession must be organized for self-protection, and that there was no other body except the Association within measurable distance of being able to do this, was it not short-sighted and futile to remain outside because of something that had happened in the past? The man who held strong views should do his best to influence his fellows, and he could not do that if he held aloof from the only medico-political body that counted. As to the second point, this had been explained so often that his audience must be as tired of it as he was, and it was perhaps enough to say that the Association had never failed to protest against the reduction of the notification fee, that it had done its best to induce the Minister to withdraw it, and then to get Parliament to throw out the clause in the bill which authorized it, but without success. The critics always failed to suggest what more could be done by any section of the community when Parliament had decided against it on any point. True, the medical profession might have become "passive resisters" or taken "direct action" on the matter, but he had yet to meet any medical man or woman whose opinion he valued who would have supported the Council of the Association if they had suggested anything so inimical to the best interests of the nation or the profession. He was forced to the conclusion that those who gave this as their reason for leaving or refusing to join the Association were either very hard put to it for a reason, or were very short-sighted, and he had great difficulty in taking them seriously. As to that section which doubted if the Association had power to protect its members, he was content that the Association should be judged by its record, and to give several recent instances of what it had done and could do. It was an undoubted fact that members of Parliament and the public generally believed that the British Medical Association was a very powerful body, and he for his part declined to try to persuade them to the contrary, though the critics of whom he spoke never lost an opportunity of doing so. Whether or not this was a good thing for the interests of the profession as a whole, he left his audience to judge. However, while these critics held aloof the Association would go on with its work, and it was for the Divisions, without which the Association would be helpless, to do their part. They had done it most efficiently and successfully in the late agitation about the Dangerous Drugs Regulations, and he ventured to say that the effect of that agitation on the minds of members of Parliament and on the Home Office was a hard nut to crack for those who tried to persuade themselves that the Association was a powerless and effete body—quite good for social and scientific purposes, perhaps, but negligible in medico-political matters.

The Association, Dr. Cox continued, benefited the public by promoting the art and science of medicine; in this its record of nearly ninety years was one to be proud of. It had given many eminent medical men assistance by its scholarships and grants at a time when they needed it most. It had promoted legislation on matters affecting the public; it had run risks in exposing quackery; and its JOURNAL was acknowledged to be the premier medical journal of the Empire. All these things were, directly or indirectly, for the benefit of the public and they gave the

Association a prestige in medical affairs which greatly assisted it when it appealed to the public and the Government on questions affecting the profession. Moreover, it was in the public interest that every profession and calling should have some organized body which could be relied upon to voice the opinions of that calling, and this the Association did for the medical profession to the best of its ability—that is, as far as practitioners authorized and encouraged its efforts by joining it.

In conclusion, Dr. Cox warned his hearers that the medical profession could not hope to escape from the difficulties which every class would have to meet in trying to adjust themselves to the new economic conditions. Those classes which were not organized might easily find themselves unjustly treated in the struggle. Those practitioners who stood outside the British Medical Association always expected it to defend the interests of the profession in matters of this kind, and indeed they were its severest critics when it fell short of getting what the critics themselves thought it should have got. He therefore asked those who in the past had supported the Association to continue to do so more actively than ever, and those who had hesitated to join it to do so, in the belief that the interests of the profession were safe in its hands and that those of the public would be respected.

A hearty vote of thanks to the lecturer was proposed by the CHAIRMAN and seconded by Dr. GRIERSON, supported by Dr. J. E. GAINS. The members present were afterwards kindly entertained to tea by Dr. and Mrs. Grierson.

METROPOLITAN COUNTIES BRANCH: WILLESDEN DIVISION.
The annual meeting of the Willesden Division was held on May 17th at St. Andrew's Parish Institute, Willesden Green, when Dr. J. S. CRONE was in the chair. The Chairman submitted a report on the work of the past year. The Division now had a membership of sixty, and he felt that much of its present healthy condition was due to the activities of the honorary secretary, Dr. Wm. Paterson. One of the most interesting meetings during the year was that held at the local municipal hospital, where they were entertained by the local council and inspected the wards, etc., of the hospital. What was probably the largest meeting of the local profession ever held was that at which Lord Dawson explained the Report of the Medical Consultative Council of the Ministry of Health on the future of medical practice. Several matters had been discussed by the Division during the year, and very interesting debates had taken place upon the Annual Report of the Medical Officer of Health. Dr. Christine Murrell had given an address on maternity and child welfare work, which was followed by a debate, during which, with the assistance of the Deputy Medical Secretary of the Association (Dr. G. C. Anderson), the meeting had gone thoroughly into the proposals of the Medical Officer of Health as to the employment of part-time practitioners in connexion with maternity and child welfare work. An important aspect and, Dr. Crone thought, a new departure locally, was the recognition of the Division as the representative and spokesman of the medical profession of the district. For the first time within his recollection representatives of the Division had sat in conference with representatives of the public bodies of Willesden. The special Maternity and Child Welfare Committee of the Division had addressed a questionnaire to every practitioner in the area, and had received replies from fifty-five. The Committee now awaited the result of the conferences of the Council before drawing up a scheme. Non-members had been invited to all the meetings of the Division as they were very glad to see non-members present and better pleased to secure them as recruits to the Association. The British Medical Association was, after all, the bulwark of the general practitioner, and was the largest association of its kind in the kingdom. It might have its faults, but there was no body of men free from faults, and though he had belonged to a great number of medical bodies he held the opinion that the British Medical Association was the pick of the lot.

The Chairman said, in conclusion, that the Association had, during the past year, devoted a considerable portion of its valuable time to the affairs of Willesden, more so than in any other year, and he proposed:

That the Division place on record its thanks to the members of the Branch and Central Councils of the Association for the interest they have shown in the affairs of the Willesden Division during the past year.

This was carried, and the Chairman's report was adopted and ordered to be entered on the minutes.

The following officers have been elected for 1921-22:

Chairman: Dr. C. F. T. Scott. Vice-Chairman: Dr. C. H. Anty. Honorary Secretary: Dr. Wm. Paterson. Representative in Representative Body: Dr. Wm. Paterson. Deputy Representative in Representative Body: Dr. C. F. T. Scott. Clinical Secretary: Dr. G. W. R. Skene.

Dr. SCOTT, in proposing a vote of thanks to the retiring chairman, Dr. J. S. Crone, said that Dr. Crone's acceptance of the chairmanship had added just one more piece of work to the many he had done for the benefit of his profession in the locality. The motion was carried unanimously, and Dr. CRONE, in returning thanks, said he had felt honoured so long ago as 1891, when he was elected the first Vice-President of the old Willesden Medical Society and President the following year, but

he considered that the highest honour the medical profession of a locality could bestow upon one of their number was to elect him Chairman of the Division of the Association in which he had worked for so many years.

MEETINGS TO BE HELD.

CAMBRIDGE AND HUNTINGDON BRANCH.—The seventy-seventh annual meeting of the Branch will be held at Harlech House, Burwell, on Friday, July 1st, at 12.30 p.m., when the financial statement for the past year will be presented and the officers for 1921-22 elected. Luncheon, by the kind invitation of the president-elect, Mr. O. R. Ennion, will be served in the Gardner Memorial Hall at 1.30 p.m. At 2.45 p.m. Mr. Ennion will deliver his presidential address, entitled "With the Field Ambulance at Gallipoli." At 4 p.m. Mr. and Mrs. Ennion will be "At home" at Harlech House.

DORSET AND WEST HANTS BRANCH.—The summer meeting will be held at 3 p.m. on Wednesday, July 6th, at the Grosvenor Hotel, Swanage, Dr. F. C. Bottomley, O.B.E. (President), in the chair. Mr. A. Basil Rooke, F.R.C.S. (Vice President) will read a paper on "Some diagnostic problems in general practice." Luncheon will be served at the Grosvenor Hotel at 1.30 p.m.; price 4s. Tea will be provided after the meeting by the kind invitation of the Swanage practitioners. Members are invited to view the new Children's Hospital at Swanage. Arrangements will be made for those not travelling by private cars from Bournemouth and district to travel by motor coach or taxi. Application should be made to Dr. Asten, Talbot Hill, by July 5th.

EAST YORKS AND NORTH LINCOLN BRANCH.—The sixty-fifth annual meeting of the above Branch will be held at Grimsby on Friday, July 15th. The place and hour of meeting will be announced later. Business: Election of officers and presidential address. Nominations must be in the hands of the honorary secretary before July 1st.

EDINBURGH BRANCH.—The annual meeting of the Edinburgh Branch will be held in the Hall of the Royal College of Physicians, 9, Queen Street, Edinburgh, on Thursday, June 30th, at 4 p.m. Tea will be served at 3.45. Business: Report of Branch Council. Annual Reports of Branch and of Divisions. Treasurer's Financial Statement. Election of office-bearers for 1921-22. Report of Election of Representative for 1921-22 to the Council of the Association for the Edinburgh and Fife Branches. Election to annual vacancy on the Board of Management of the Queen Mary Nursing Home. Proceedings of Scottish Committee. Correspondence from Medical Secretary. Annual Report of Council and Annual Representative Meeting. Any other competent business.

METROPOLITAN COUNTIES BRANCH: LEWISHAM DIVISION.—A meeting of the Lewisham Division will be held on Tuesday, June 28th, at 8.30 p.m., at 359, High Street, Lewisham, S.E.13. Agenda: Minutes; correspondence; discussion of Annual Report of Council; any other business.

NORTH LANCASHIRE AND SOUTH WESTMORLAND BRANCH.—The annual meeting will be held at 3 p.m. on Wednesday, June 29th, at the Corporation Hotel, Lancaster (near Royal Lancaster Infirmary). Business: Minutes. Annual Report. Financial Report. Election of office-bearers. X-ray Demonstration. Pathological Exhibits. The President (Dr. A. S. Barling) invites members to tea at the hotel.

OXFORD AND READING BRANCH.—The annual meeting of the Branch will be held at Maidenhead on Wednesday, July 6th, at the Town Hall at 3.30 p.m. Any members wishing to show cases or read notes should communicate at once with Dr. E. W. Squire, 223, King's Road, Reading. Dinner will be arranged afterwards at one of the riverside hotels. Those intending to be present and having room in their cars or requiring a lift are asked to write to the secretary.

STAFFORDSHIRE BRANCH: MID STAFFORDSHIRE DIVISION.—The eighteenth annual general meeting of the Division will be held on Sunday, June 26th, at 3 p.m., at the Shrewsbury Arms, Rugely. Agenda: Reports of representatives; annual report of Executive Committee; election of officers; Dr. Holder will propose the following resolution: "That the Executive Committee of the Division investigate the matter of readjustment of Divisional boundaries with a view to obviating existing difficulties in working the area, and report to a general meeting at an early date"; any other business.

SURREY BRANCH.—The annual meeting of the Surrey Branch will be held at Guildford on Friday, July 8th.

SUSSEX BRANCH.—The eighth annual general meeting of the Sussex Branch will be held at the Art Gallery, Worthing, on Wednesday, June 29th, at 2 p.m. Agenda: Correspondence; resignation of Honorary Secretary and Treasurer; election of officers; induction of President to the chair; annual report and financial statement submitted by the Council; other business. The President-elect, Dr. Frank Hinds, invites to lunch at 1 p.m. those members who intend to be present at the meeting. Members proposing to accept should immediately notify Dr. F. Hinds (Lynton House, 17, Tennyson Road, Worthing). In the afternoon a golf match will be played between East and West Sussex on the Worthing links; members who play are requested to bring their clubs. An excursion by char-a-banc will start at 2.30 p.m. from Worthing Museum for the golf links and Newport. At Cissbury Camp Mr. A. Hadrian Allcroft, M.A., will give an informal address on the early history of the camp.

Members will be conveyed from the golf links by char-a-banc to Worthing Museum. By invitation of the Museum and Art Gallery Committee a reception and tea will be given at the Art Gallery at 4.30 p.m.; the museum will be open for members and their wives.

WORCESTERSHIRE AND HEREFORDSHIRE BRANCH.—The annual meeting of the Worcestershire and Herefordshire Branch will be held at the Infirmary, Worcester, on June 30th, at 3 p.m.

Association Notices.

REPRESENTATIVE MEETING.

DATE.

THE Annual Representative Meeting at Newcastle will begin on Friday, July 15th, 1921, at 10 a.m.

NOTICES OF MOTION AND AMENDMENT BY DIVISIONS AND BRANCHES.

The Supplementary Report of Council to the Representative Meeting will appear in the SUPPLEMENT of July 2nd, 1921.

Notices of Motion and Amendment by Divisions and Branches for consideration by the Annual Representative Meeting will be published in the SUPPLEMENT as they are received, but none can be published later than July 2nd, for which purpose they must be received by the Medical Secretary not later than the first post on Monday, June 27th.

It will be possible, however, to include in the Agenda for the Annual Representative Meeting all Notices of Motion and Amendment which are received by the Medical Secretary *not later than the first post on Monday, July 1st, 1921.*

INSURANCE.

LONDON PANEL COMMITTEE.

Excess Prescriptions.—At the meeting of the London Panel Committee on May 24th it was agreed to inform the practitioners on the panel of the cost of the drugs and appliances ordered by them during 1920, as compared with the average for the year. It was pointed out that practitioners were now ignorant of the cost of the drugs they were ordering, whereas under the old arrangements, by which they were informed quarterly of the amount of their drugs bills, they were able to exercise greater control if they found that their figures were above the average.

Limitation of Lists.—The position of women practitioners on the panel who limit their lists to female patients was considered. The Committee recorded its view that the present arrangement whereby 7½ per cent. is deducted from the remuneration of such practitioners is not equitable, inasmuch as the limitation is not a complete one, the practitioners being prepared to accept the assignment of female patients. The view was taken that the appropriate clause of the Distribution Scheme should be amended so as to allow of a reduction of 3½ per cent. in cases of limitation to one sex.

Payment for Emergency Treatment.—A letter was read from the Ministry of Health with regard to the matter of payment for emergency treatment. The Conference of Panel Committees in October last passed a resolution complaining of the rule by which an insured person requiring emergency treatment outside the area in which his insurance practitioner resided was regarded as a temporary resident. The Ministry stated that the difficulty contemplated in such a resolution appeared to be mainly that which arose in the case of insured persons who, being on the list of a practitioner in their home area, left their home daily to work in some other district, and returned to their place of residence in the evening. The Ministry suggested that if the Panel Committee and Insurance Committee so agreed a clause might be inserted in the Distribution Scheme as follows:

"Provided that if an application for treatment is made by an insured person who is outside the radius of practice of the practitioner responsible for his treatment, and intends to remain outside the radius for less than twenty-four hours, the practitioner providing treatment will, instead of having the applicant placed on his list, be entitled to be paid as though the treatment had been given in an emergency under the last preceding clause (preceding Clause 4), and the amount paid to the practitioner will be payable out of the Fund in the same manner and subject to the same conditions as payments made in respect of the administration of anaesthetics."

The Committee agreed to this suggested alteration.

Naval and Military Appointments.

ROYAL NAVAL MEDICAL SERVICE.

THE following appointments are announced by the Admiralty:—Surgeon Commanders: W. P. Walker to the *Hermiton*; A. J. Wernet to the *Pembroke*, for R.N. Barracks; H. D. Drennan, D.S.O., to the *Triton* for special service, April 9th, and to the *Fidra*, for R.N. Barracks, July 16th; A. B. Marsh, to the *President*, for R.N. College, Greenwich (temporary); J. P. H. Greenhalgh, to the *Fidra* (temporary), for Plymouth Hospital; J. Macdonald, to the *Crescent*, as Senior Medical Officer and Medical Transport Officer; E. Cameron, to the *Crescent*.

Surgeon Lieutenant Commanders: J. G. Boal, to the *Impregnable*; G. A. M. Anderson, to the *Wisteria*. Surgeon Lieutenants: T. Madill and J. F. H. Gausson, to the *Victoria*, additional, for Haslar Hospital; J. W. Tighe and M. Brown, for the *Victoria*, for Haslar Hospital; A. W. Cocking, to the *Crescent*, for R.N. Sick Quarters, South Queensferry.

Surgeon Lieutenant T. Gwynne-Jones has been promoted to the rank of Surgeon Lieutenant Commander.

ARMY MEDICAL SERVICE.

ROYAL ARMY MEDICAL CORPS.

Lieut.-Colonel E. P. Hewitt retires on retired pay.
Captains relinquish the acting rank of Major: T. K. Boney, H. G. Winter, M.C.

Temporary Captains to be temporary Majors whilst specially employed: H. St. A. Acate, M.C., A. G. Higgins.
The Christian names of Captain Gordon Ernest Lovell Simons are as now described, and not as stated in the *London Gazette* of April 11th, 1919.

Temporary Captain A. C. Profeit relinquishes his commission, July 6th, 1919, and is granted the rank of Major (substituted for notification in the *London Gazette*, July 31st, 1919).

R. W. Harper, late temporary Captain, to be temporary Captain, with seniority January 28th, 1916.

ROYAL AIR FORCE.

MEDICAL BRANCH.

Squadron Leader H. V. Porteous is seconded for duty with the South African Air Force.

SPECIAL RESERVE OF OFFICERS.

ROYAL ARMY MEDICAL CORPS.

Captain R. Magill, D.S.O., relinquishes the acting rank of Major.
Captain M. C. Joynt to be acting Major from December 1st, 1919, to January 11th, 1920.

Captain D. Clyde relinquishes his commission on appointment to a permanent commission in the Indian Medical Service.

TERRITORIAL FORCE.

ROYAL ARMY MEDICAL CORPS.

Lieut.-Colonel C. H. Howkins, C.B.E., D.S.O., T.D., resigns his commission, and is granted the rank of Colonel with permission to wear the prescribed uniform.
Lieut.-Colonel (Brevet Colonel) T. H. Haydon, having attained the age limit, is retired and retains his rank.

Major W. Bryce, T.D., having attained the age limit, is retired, and is granted the rank of Lieutenant-Colonel with permission to wear the prescribed uniform.

Major J. A. Kendall resigns his commission and retains the rank of Major.

Major T. Martin (late R.A.M.C.) to be Captain, with precedence as from February 15th, 1918, and relinquishes the rank of Major.
Captain J. W. Kemp to be Major.

Captain H. E. S. Richards, M.C., is seconded for service under the Colonial Office.

Captain R. F. Gerrard resigns his commission, and retains the rank of Captain.

Captain D. C. Graham (late R.A.M.C.) to be Lieutenant, with precedence as from April 1st, 1915, and relinquishes the rank of Captain.

A. H. Crook (late Surgeon Lieutenant R.N.V.R.) to be Captain, with precedence as from April 1st, 1915—August 17th, 1920. (Substituted for notification in the *London Gazette* of January 17th, 1921.)

Lieutenant L. H. Taylor to be Captain.
2nd *London Sanitary Company*.—Lieutenant S. H. Kemp resigns his commission and retains the rank of Lieutenant.

DEFENCE FORCE.

ARMY MEDICAL SERVICE.

To be Assistant Director of Medical Services: Temporary Colonel C. I. Ellis, C.M.G.

R.A.M.C.—To be temporary Majors: Temporary Captains O. Teichman, D.S.O., and S. S. Greaves whilst specially employed, J. C. S. Burkitt. To be temporary Captains: H. G. L. Allford, A. H. Fullerton, M. H. Barton, M.C.

The notification regarding J. E. Sinclair in the *London Gazette* of May 10th 1921, is cancelled.

Temporary Captain R. M. Wilson relinquishes his commission.
3rd *Divisional Sanitary Section (D.F.)*.—To be temporary Captain: P. W. Kent.

2nd *(East Anglian) Field Ambulance (D.F.)*.—To be temporary Lieutenant-Colonel: S. J. Fielding, April 11th (substituted for notification in the *London Gazette*, May 3rd, appointing the officer as temporary Major).

1st *(East Anglian) Field Ambulance (D.F.)*.—To be temporary Lieutenant-Colonel: C. S. Wink.

1st *(East Lancashire) Field Ambulance (D.F.)*.—R. MacKinnon (Captain R.A.M.C., S.R.) is granted the rank of temporary Major.

2nd *(Lowland) Field Ambulance (D.F.)*.—Temporary Major J. R. C. Greenlees relinquishes his commission.

1st *(Highland) Field Ambulance (D.F.)*.—To be temporary Major: F. M. Rorie, April 9th (substituted for notification in the *London Gazette*, May 6th, 1921, appointing this officer as temporary Captain).

1st *(Home Counties) Field Ambulance (D.F.)*.—To be temporary Lieutenant-Colonel: E. A. Houchin (substituted for notification in the *London Gazette* of May 10th appointing this officer as temporary Captain).

2nd *(Home Counties) Field Ambulance (D.F.)*.—G. A. Blake (Captain, Brevet Major R.A.M.C.) is granted the rank of Lieutenant-Colonel while commanding a field ambulance. To be temporary Major: R. A. Freeman, April 12th, 1921 (substituted for notification in the *London Gazette* of May 9th appointing this officer as temporary Captain).

1st *(North Midland) Field Ambulance (D.F.)*.—A. E. Miller (Major R.A.R.O.) is granted the rank of temporary Lieutenant-Colonel while commanding a field ambulance.

2nd *(North Midland) Field Ambulance (D.F.)*.—To be temporary Lieutenant-Colonel: G. B. Gill. To be temporary Major: T. C. Clare. To be temporary Captains: G. R. Jackson, J. Donald. To be temporary Lieutenant: T. N. C. Atkinson.

3rd *(North Midland) Field Ambulance (D.F.)*.—To be temporary Lieutenant-Colonel: J. Miller, D.S.O., M.C. To be temporary Major: G. F. Haycraft. To be temporary Captains: R. B. Lilly, W. W. Hallchurch.

British Medical Association.

OFFICES AND LIBRARY, 429, STRAND, LONDON, W.C.2.

Reference and Lending Library.

THE READING ROOM, in which books of reference, periodicals, and standard works can be consulted, is open to members from 10 a.m. to 6.30 p.m., Saturdays 10 to 2.

LENDING LIBRARY: Members are entitled to borrow books, including current medical works; they will be forwarded, if desired, on application to the Librarian, accompanied by 1s. for each volume for postage and packing.

Departments.

SUBSCRIPTIONS AND ADVERTISEMENTS (Financial Secretary and Business Manager, Telegrams: Articulate, Westrand, London).
MEDICAL SECRETARY (Telegrams: Medisecra, Westrand, London).
EDITOR, *British Medical Journal* (Telegrams: Aitiology, Westrand, London).

Telephone number for all Departments: Gerrard 2630 (3 lines).

SCOTTISH MEDICAL SECRETARY: 6, Rutland Square, Edinburgh, (Telegrams: Associate, Edinburgh. Tel.: 4361 Central.)

IRISH MEDICAL SECRETARY: 16, South Frederick Street, Dublin. (Telegrams: Baecillus, Dublin. Tel.: 4737 Dublin.)

Diary of the Association.

JUNE.

- 24 Fri. Metropolitan Counties Branch Annual Meeting, 429, Strand, W.C.2, 4 p.m.
26 Sun. Mid Staffordshire Division, Annual Meeting, Shrewsbury Arms, Rugeley, 3 p.m.
28 Tues. Lewisham Division, 359, High Street, Lewisham, S.E.13, 8.30 p.m.
29 Wed. London: Propaganda Subcommittee, 2.15 p.m. North Lancashire and South Westmorland Branch, Annual Meeting, Corporation Hotel, Lancaster, 3 p.m. Sussex Branch; Annual Meeting, Art Gallery, Worthing, 2 p.m.
30 Thur. Edinburgh Branch, Annual Meeting, Hall of the Royal College of Physicians, 9, Queen Street, 4 p.m. Worcestershire and Herefordshire Branch: Annual Meeting, The Infirmary, Worcester, 3 p.m.

JULY.

- 1 Fri. London: Agenda Committee, 2.30 p.m. Cambridge and Huntingdon Branch, Annual Meeting, Hatched House, Burwell, 12.30 p.m. Luncheon, 1.30 p.m.
6 Wed. London: Hospitals Committee, 2.30 p.m. Dorset and West Hants Branch, Summer Meeting, Grosvenor Hall, Swage, 3 p.m. Luncheon, 1.30 p.m. Oxford and Reading Branch Annual Meeting, Town Hall, Maidenhead, 3.30 p.m.
8 Fri. Surrey Branch Annual Meeting, Guildford.
15 Fri. East Yorks and North Lincoln Branch, Annual Meeting, Grimsby.

DIARY OF SOCIETIES AND LECTURES.

ROYAL SOCIETY OF MEDICINE.—Section of Odontology: Mon., 8 p.m., Mr. Kelsey Fry: Dental Treatment of Congenital and other Perforations of the Palate.

POST-GRADUATE COURSES AND LECTURES.

HOSPITAL FOR SICK CHILDREN, Great Ormond Street, W.C.—Thurs., 4 p.m., Dr. Poynton: Pericarditis.

LONDON HOSPITAL MEDICAL COLLEGE, E.—(Surgical Unit): Mr. Hugh Lett, C.B.E., 4.15 p.m., Tues.: Stricture of the Urethra; Thurs.: Retention of Urine.

NORTH-EAST LONDON POST-GRADUATE COLLEGE, Prince of Wales's General Hospital, Tottenham, N.15.—Daily, 2 p.m., In- and Out-patient Clinics, Operations, etc. *Lecture-Demonstrations*:—3 p.m., Tues., Mr. C. H. Hayton: Anatomy of the Pharynx and Larynx, with Methods of Examination. Wed., Mr. W. E. Tanner: Acute Bone Disease. Fri., 4.30 p.m., Dr. C. E. Sandell: Physiology of Digestion in Infants.

QUEEN'S HOSPITAL FOR CHILDREN, Hackney Road.—Thes., 4 p.m., Mr. K. A. Lees: Chronic Otitis Media. Thurs., 12 noon, Mr. V. Nesfield: Temporary Treatment of Acute Glaucoma by Paracentesis.

WEST LONDON POST-GRADUATE COLLEGE, Hammersmith, W.—Daily, 10 a.m., Ward Visits; 2 p.m., In- and Out-patient Clinics and Operations. *Lectures*:—5 p.m., Mon., Mr. Armour: Diseases of the Gall Bladder and Ducts. Tues., Dr. Simson: Abortion. Wed., Mr. Baldwin: Surgery of the Rectum. Thurs., Sir Thomas Horder: Investigation and Immediate Treatment of a Case of Acute Pyogenic Infection. Fri., Mr. T. Gray: Surgical Physiology of the Alimentary Tract.

BIRTHS, MARRIAGES, AND DEATHS.

The charge for inserting announcements of Births, Marriages, and Deaths is 9s., which sum should be forwarded with the notice not later than the first post on Tuesday morning, in order to ensure insertion in the current issue.

MARRIAGES.

CONNOR—LEES.—At the British Embassy Church, Paris, on Saturday, June 11th, Brevet Lieut.-Colonel Frank Powell Connor, D.S.O., F.R.C.S., Indian Medical Service, son of the late James Connor, and Grace Ellen, daughter of Reginald O. Lees, late Director, Indian Government Telegraphs.

SHEPHERD—GORDON.—On June 2nd, at St. John's Wood Presbyterian Church, London, George A. Shepherd, M.B., Ch.B., Mornington House, Old Southgate, London, N., to Coral Ogilvie, M.B., Ch.B., elder daughter of the late Dr. John Gordon, Aberdeen, and of Mrs. Ogilvie Gordon, D.Sc., J.P., 34, Abbey Road, N.W.8.

STUART—GRAY.—On the 18th inst., at Marylebone Presbyterian Church, London, G. Stuart, M.A., M.B., Ch.B., Assistant Director of Health, Government of Palestine, to Elizabeth Gray, M.B., Ch.B., Fochabers, Morayshire.

THE
British Medical Journal.

THE JOURNAL OF THE BRITISH MEDICAL ASSOCIATION.

EPITOME

OF

Current Medical Literature.

JANUARY TO JUNE, 1921.

London :

PRINTED AND PUBLISHED AT THE OFFICE OF THE BRITISH MEDICAL ASSOCIATION,
429, STRAND, W.C.

INDEX TO THE EPITOME FOR VOLUME I, 1921.

READERS in search of a particular subject will find it useful to bear in mind that the references are in several cases distributed under two or more separate but nearly synonymous headings—such, for instance, as Brain and Cerebral; Heart and Cardiac; Liver and Hepatic; Renal and Kidney; Cancer and Carcinoma, Epithelioma, Malignant Disease, New Growth, Sarcoma, etc.; Child and Infant; Bronchocele, Goitre, and Thyroid; Diabetes, Glycosuria and Sugar; Eye, Ophthalmia, and Vision, etc.

The Figures in this Index refer to the Number of the Paragraph, NOT the Page.

A.

AASER: Diphtheritic heart and its treatment, 107
 Abdominal cavity, five year old foetus loose in, 139
 Abdominal hysterectomy for puerperal infections, 92
 Abdominal operations, local anaesthesia for, 121
 Abdominal wall, spontaneous haematoma of, 492
 ABELS: Dentition and febrile processes, 230—Scurbic dysery, 382
 Abortion, criminal, air embolus after, 714
 Abortion, febrile cases of, treatment of, 467, 519
 Abortion, missed, 468
 Abortion and pre-mature labour, causes of, 635
 Abortion, septic, treatment of, 191, 738
 Abortions, repeated, etiology of, 547
 ABAMOFF: Histology of the measles exanthem, 510
 ABRAHAMSEN: Thyroid extract in Köhler's disease, 531
 Abscess of brain following wounds, 328
 Abscess, dissecting, of caecal wall, 147
 Abscess, mastoid, pharyngeal suppuration secondary to, 244
 Abscess, retropharyngeal, 677
 Abscess of tonsil, fatal case of, 331
 Acid, pepsin-hydrochloric, digestion of kelooids, cicatrices, and buboes with, 315
 Acne vulgaris, x-ray treatment of, 617
 Acoustic nerve tumours, 439
 Acriflavine irrigation in gonorrhoea, 512
 Acrobrachycephaly, 43
 Acromegaly, radium therapy of, 208
 ADELADI: Pulmonary syphilis, 426
 Adenitis in herpes zoster, 6
 Adenitis, tuberculous, limitations of x-ray treatment in, 629
 Adenofibromata of the breast, 302
 Adenoma sebaceum and renal tumours, 398
 Adrenaline in erythromelalgia, 142
 Adrenaline and novocain injections in erysipelas, 621
 ADRIAN: Arthropathies in sclerodermia, 266
 Africa, South, psoriasis in, 533
 Agnesia cerebellar, 320
 AHLWEDE: Digestion of kelooids, cicatrices, and buboes with pepsin hydrochloric acid, 315
 AIEVOLI: Torticollis, 54
 Air embolus after criminal abortion, 714
 ALAMANN: Small mucous polypi of the corpus uteri as a cause of haemorrhage, 574
 ALBECK: Pregnancy and the thyroids, 62
 Alcoholism, chronic, the corpus callosum in, 225
 ALEXANDER: Echinococcus disease of the lung and pneumothorax treatment, 357—Bronchial asthma, 619
 ALTHAN: Treatment of nasal sinusitis, 181
 Alimentary amenorrhoea, 445
 Alkaptonuria, 579
 ALMASIO: Relation of lethargic encephalitis to influenza, 456
 Alveolectomy, 569
 Amenorrhoea, alimentary, 445
 Ammonia, microchemical test for, 36
 Amoeba, parasitic, in the tonsils, 100
 ANOB: Polycystic ovarian changes, 122
 ANOSS: Serum treatment of acute poliomyelitis, 317
 Amyloid disease of the lung, 556
 Amytonia congenita, 129
 Anaemia, treated by nucleinate of manganese, 298
 Anaemia of consumptives and intestinal tuberculosis, 455
 Anaemia, pernicious, in childhood, 205—Treated by splenectomy, 405—And malaria, 705
 Anaemia, physiological, of pregnancy, 218
 Anaemia, pseudo-leukaemic splenic, in infants, 643
 Anaerobic flora in intestinal diseases, 193
 Anaesthesia, treatment of the excitement stage of, 564
 Anaesthesia, continuous ether, during childbirth, 573
 Anaesthesia, local, for abdominal operations, 121
 Anaesthesia, spinal, action of on the hepatic and renal functions, 710
 Epit. 2

Anaesthetic, a new (diethyl-diallyl-barbiturate of diethylamine), 85
 Anaesthesia, lumbar, 461
 Anaesthesia, rectal, 241
 Anaesthesia, effect of injections of sugar on, 327
 Anaesthesia, nitrous oxide oxygen, death from, 628
 Anaphylactic shock, prevention of, 522
 Anastomosis, sapheno-femoral, 411
 ANDERDIAS: Glycosuria in pregnancy, 153—The islands of Langerhans in diabetes, 222—"Eclampsia" fits in a case of chronic nephritis after decapsulation of the kidneys, 661
 Aneurysm of the hepatic artery, 211
 Aneurysms of the cystic and splenic arteries, 614
 Angiomata of larynx, 332
 Angina, Ludwig's, in a haemophilic subject, 359
 Angina, Vincent's, association of tonsillar chancre with, 678
 ANGLADE: Glioma of the nasal fossae, 19—Morbid anatomy of lethargic encephalitis, 366
 Anion, epidemic encephalitis at, 136
 Antibody formation in leukaemia, failure of, 367
 Antigens, partial, in treatment of surgical tuberculosis, 538
 Antimony. See Tartar emetic
 Antipneumococcus serum, 290
 Antistaphylococcal vaccine in treatment of osteomyelitis, 47
 ANTONIS: Infective processes in the teeth and internal diseases, 503
 Anuria, reflex calculous, 178
 Anus, malformations of, 655
 Aortic disease, disturbance of deglutition in, 45
 Aortitis syphilitic, case of, 40
 Appendicitis: Diagnosis of, 272—Pain in the left side in, 437—Simulated by acute anterior poliomyelitis, 510—Characteristics of in old age, 681
 Appendicitis, chronic, 410—Dyspeptic symptoms due to, 566
 ARCANGELI: Perforation in typhoid fever, 373
 ARGAUD: Gland tubules in the Fallopian tubes, 187
 ARIAZZI: Sachs Georgi reaction in syphilis, 449
 ARLOING: Neutrophile leucocytes in pulmonary tuberculosis, 255
 ARNSTEIN: Herpes zoster as the only sign of latent disease, 323
 ARIGNONI: Subcutaneous oedema in sero-fibrinous pleurisy, 509
 Arsenical paralysis due to neo-salvarsan, 73
 Arsenobenzol, splenomegaly due to, 269
 Arterial pulse wave, rate of propagation of, 720
 Arteries, cystic and splenic aneurysms of, 614
 Arterio-sclerosis and dementia praecox, 78
 Arterio sclerosis and chronic nephritis, hypertension in, 68
 Artery, hepatic, aneurysm of, 211
 Arthritis, acute, in infants, 507
 Arthritis, metapneumococcal, 363
 Arthropathies in sclerodermia, 266
 Artificial pneumothorax, consecutive bilateral, 139—Duration of, 645
 Artificial pneumothorax in fractured ribs, 329
 Artificial pneumothorax, pleural effusions in, 476, 477, 644
 Artificial pneumothorax, pleurisy with effusion on the "sound" side in, 644
 Artificial pneumothorax in bilateral tuberculosis, 646
 Artificial pneumothorax in treatment of pulmonary tuberculosis, 209, 478
 ASCOLI: Irradiation of the hypophysis in bronchial asthma, 169
 ASKGAARD: Bilateral peripheral facial paralysis, 141
 Asphyxia, fatal, from food-block, 274
 Asthma, bronchial, 133, 619—Irradiation of the hypophysis in, 169—Vaccine treatment of, 672
 Astigmatism, influence of age upon, 215
 Astragalus, removal of in paralytic feet, 86
 Athletics, influence of on the heart, 312
 Auditory nerve, tumours of, 526
 AURER: Insertion of the round ligaments and diagnosis of impending rupture of uterus, 23
 AUBAND: Thrombosis of the central artery of the retina following ophthalmic zoster, 182

Auricular flutter and fibrillation in pregnancy, 653. See also Heart and Cardiac
 AUSTGEN: War injuries and tuberculosis, 532
 AUTONI: Oesophageal stricture, 409
 Auto-anaphylaxis in paroxysmal haemoglobinuria, 500
 Auto haemotherapy, prurigo cured by, 534
 Auto-transfusion for haemorrhage, 273
 Auto urine reaction in tuberculosis, Wild-ly 78, 195
 Auto-vaccination for acute suppurative otitis media, 571
 Aviators, blood pressure of, 2
 AZA: Pregnancy and cardiac insufficiency, 633
 AZZI: Peripheral vasomotor and pulmonary reactions, 65

B.

B. proteus vulgaris in cholera infantum, etiological significance of, 498
B. tetani in the digestive tract of herbivora, 695
 Bacteria, influence on the metabolism of, 370
 Bactericidal power of the intestinal mucosa, 551
 BAER: Indirect expulsion of the placenta, 518
 BAILEY: Atypical epidemic encephalitis, 667
 BAIN: Thrombosis of the splenic vein, 295
 BAKER: Compression fractures of vertebrae, 299
 BALDWIN: Death from nitrous oxide-oxygen anaesthesia, 628
 BALLENGER: Treatment of orchitis in mumps, 119
 BALSAMO: Rectal anaesthesia, 211
 BANG: Purulent meningitis in uraemia, 673
 BANGMAN: Pelvic lavage in treatment of pyelitis of pregnancy, 689
 BARDE: A new anaesthetic (diethyl-diallyl-barbiturate of diethylamine), 85
 Barium sulphate in treatment of gastric and duodenal ulcer, 702
 BARKER: X-ray therapy in hyperthyroidism, 592
 BARLOCCO: Changes in the heart and circulation due to muscular exercise, 285
 Barlow's disease, epidemic of, 343
 BARNES: Tourniquet for intravenous injections, 735
 BARNEX: Tuberculosis of the male genital tract, 462
 BARON: Meningococcal urethritis, 552
 BASILE: Respiratory mycoses, 267
 BARSONY: Morning pain in renal and ureteral calculus, 734
 BAUER: Lethargic encephalitis in Switzerland, 236—Central rupture of liver, 330
 BÄBERG: Spontaneous haematoma of the abdominal wall, 492
 BAUMBERGER: Smoking and mental activity, 110
 BECKER: Cervico-vaginal fistulae, 89—Complement fixation tests in the hosts of *Bothriococcium latens*, 253
 BECLINE: Radiation treatment of carcinoma of uterus, 308—Radiotherapy of the endocrine glands, 429—Sterilization of ovaries by x-ray, 636
 BENEJ-JONES: Proteinuria, 525
 BENEDETTI: Mastitis in Malta fever, 50
 BENJAMINS: Intravenous injection of tartar emetic, 345
 Benzol, treatment of myeloid leukaemia with, 432
 BERARD: Hydatid thrill, 486
 BERGOLLI: Subcutaneous emphysema in measles, 379
 BERISSO: Pulmonary syphilis, 426
 BERNARD: New method of facilitating detection of tubercle bacilli, 368
 BERTOLOTTI: Radium therapy of acromegaly, 208
 BETH: Peripheral neuritis in tetany, 10
 BETRIN: Radium therapy in carcinoma of uterus, 334
 BETTAZZI: Symmetrical tuberculous ulceration of the labial commissures, 596
 BIANCHI: Injections of milk in puerperal infections, 281

BI-ESSENTIAL, M.: Use of sodium morrhuate in pulmonary tuberculosis, 238
 Bile, action of on the spinal centres, 33
 Birth, premature, by transverse presentation, threatened rupture of uterus in, 127
 Births, premature, and infant mortality, 471
 BITSCHIN: Premature separation of the normally situated placenta, 25
 Bladder: Primary tuberculosis of, 12—Spontaneous rupture of, 707
 Bladder, urinary, diverticula of, 680
 BLAMOUTIER: Herpes of the anal region with meningial symptoms, 459
 BLANC: Epidemic encephalitis at Anjou, 136
 BLANCHARD: Anterior bow-legs, 303
 BLANCO: Loose bodies in knee-joint, 568
 Blindness and oxycephaly, 4
 BLOCH: Tuberculosis of larynx cured by galvano-cauterization, 213
 Blood cells, relation between haemoglobin and number of, 497
 Blood cells in tuberculosis, rate of sedimentation of, 369
 Blood changes in lead workers, 475
 Blood corpuscles, reticulated red, 226
 Blood cultures in bubonic plague, 399
 Blood ferments in pregnancy, carcinoma and pulmonary tuberculosis, 254
 Blood in osteomyelitis, 691
 Blood platelets, enumeration of, 336—Studies in properties of, 393
 Blood pressure of aviators, 2
 Blood pressure and oedema in hemiplegia, 286
 Blood transfusion, haemoglobinuria after a second transfusion with same donor, 716
 Blood transfusion in treatment of nitrobenzol poisoning, 109
 Blood volume, determination of, 197
 BOER: Acute nitrobenzol poisoning, 723
 BOERI: Early diagnosis of pulmonary tuberculosis 7
 BOITEL: Etiology of goitre, 224
 BOLLEN: Hyperthermia as a symptom of demorphinization, 348 — Fragilitas ossium, 639
 BOMPIANI: Histology of the typhus eruption, 64
 BONAR: A peculiar fever of infancy, 618
 Bone development, 448
 Bone marrow, infective irritation of, 585
 Bone, transplanted, fate of, 408
 Bones, spongy, treatment of fractures of, 597
 Bones and joints, surgical treatment of tuberculosis of, 598
 BONHOEFFER: Encephalitis lethargica, 588
 BONNAMOUR: Purpura in cerebro-spinal meningitis, 106
 BORAX poisoning, fatal, 293
 BORCHER: Motor disturbances of the stomach and resection of the vagus, 204
 BORCHGREVINK: Local anaesthesia for abdominal operations, 121
 Berdesaux region, lethargic encephalitis in, 346
 BOSSERT: Pulmonary influenza in children, 460
Bothrioccephalus latus, complement fixation tests in the hosts of, 253
 BOUTTIER: Myoclonic encephalitis treated by cicutine, 562
 BOUVIER: Treatment of osteomyelitis with antistaphylococcal vaccine, 47
 Bowel, implantation of ureter into, 651
 Bow-legs, anterior, 303
 BOYD: Renal decapsulation in subacute nephritis, 427
 BOZZOLO: Vaccine therapy in typhoid, 261
 Brain abscess. *See* Abscess
 BRATTSTROM: Operative treatment of cancer of the breast, 383
 Breast, adenofibromata of, 302
 Breast enlargement after prostaticectomy, 304
 Breech presentation. *See* Labour
 BRENNING: Injections of turpentine in pemphigus, 505
 BRODHEAD: Vesico uterine fistula, 61
 BRODIN: Prevention of anaphylactic shock, 522
 Bronchial asthma. *See* Asthma
 Bronchial glands, non-tuberculous inflammation of, 648
 Bronchiectasis after influenza, 260; Singer's throat cure for, 647
 Bronchiolitis due to irritant gas, 77
 Bronchitis, putrid, neo-salvarsan in, 483
 Broncho-pulmonary spirochaetosis (Castellani), 375
 BROTHA: Caesarean section in infected cases, 444
 BRUENING: Removal of suprarenal capsules for epilepsy, 435
 BRUZZI: Treatment of ozaena, 515
 Baboos digested with pepsin-hydrochloric acid, 315
 Bubonic plague. *See* Plague
 BUCHANAN: Long-standing dislocations of hip, 420
 BUCHHOLTZ: Influenza statistics, 294
 BUCKMAN: Studies in properties of blood platelets, 393
 BUDDE: Diagnosis and prognosis of persistent ductus arteriosus, 405
 BULL: Thoracoplasty in the treatment of pulmonary tuberculosis, 174
 BUMPUS JUNR.: Pyelonephritis, 553
 BURGER: Pedunculated cancer of larynx, 305

BURNIER: Syphilitic mastitis, 654
 BURNS: Cholesterol in xanthoma multiplex, 371
 BURROW: Familial tabes, 162
 BUSSY: X-ray treatment of interstitial keratitis, 679

C.

Caecal wall, dissecting abscess of, 147
 Caesarean section: Three spontaneous deliveries after, 219—Management of labour after previous, 417. In infected cases, 444—For obstruction by ovarian cyst, 685—in acute oedema of the lungs, 715
 CAIRD: Intestinal tuberculosis, 388
 Calcaneum, direct fractures of, 729
 Calcium lactate, action of intravenous injections of on the blood picture, 582
 Calcini, renal, in soldiers, 385
 Calculous anuria. *See* Anuria
 Calculus, renal and ureteral, morning pain in, 734
 CALLISON: Acute purulent otitis media in children, 546
 Calomel injections in an aqueous excipient, 206
 CALRY: Contraindications to dental extractions in cardiopaths, 140
 Calvé-Perthes's disease, etiology of, 554
 Camphor, action of and haemoptysis, 352
 Cancer, blood ferments in, 254
 Cancer of bone, radium in, 542
 Cancer of breast, operative treatment for, 383
 Cancer of cervix of borderline operability, 686
 Cancer of cervix, late results of hysterectomy for, 390
 Cancer of cervix, extended hysterectomy after radium treatment of, 128
 Cancer, cutaneous, of the bridge of the nose, 537
 Cancer of duodenum, 441
 Cancer of Fallopian tube, primary, successful extirpation of, 470
 Cancer of foetal kidney, dystocia due to, 95
 Cancer of larynx, pedunculated, 305
 Cancer of oesophagus, paravertebral dullness in, 627
 Cancer of stomach with remarkable metastases, 666
 Cancer of the tongue, 466
 Cancer of uterus, early recognition of, 97—Radiation treatment of, 308—Radium therapy in, 334
 Cancer of vagina, primary, 365
 Cancer of vulva, 495
 Capillary pressure, 239
 CAPONE: Anaerobic flora in intestinal diseases, 193
 Carcinoma. *See* Cancer
 CARDENAL: Cerebral hydatid cyst, 56
 Cardiac insufficiency and pregnancy, 633
 Cardiac. *See also* Auricular and Heart
 Cardiopaths, contraindications to dental extraction in, 140
 CARLE: Is it necessary to treat the pregnant wife of a syphilitic? 363
 CARLES: Pyelonephritis following pregnancy cured by intravenous injections of urotropine, 156
 CARNOT: Hypertension in chronic nephritis and arterio sclerosis, 68
 CARTER: Dystocia due to carcinoma of the foetal kidney, 95
 CASPARI: Renal tuberculosis, 485
 CASSINIS: Artificial pneumothorax in bilateral tuberculosis, 646
 CASTELLA: Cerebral hydatid cyst, 56
 CASTELLI: Congenital malformation of mitral valve, 292
 Castration for uterine fibroma, 24
 CASTRONOVO: Diabetes and infections, 158—Recklinghausen's disease, 229
 Cataract, incipient, medical treatment of, 48
 Cattle tuberculosis. *See* Tuberculosis
 CAUCCI: Chronic intestinal stasis, 300
 CAUSADE: Hydrocephalic form of cerebro-spinal meningitis in infants, 502
 CAZEJUST: Congenital atresia and occlusion of the choanae, 626
 Cerebellar agenesis, 320
 Cerebral diplegia and Little's disease, 80
 Cerebral haemorrhage in childhood, 616
 Cerebro-spinal fever complicated by hydrocephalus, 615
 Cerebro-spinal fluid, colloidal benzoïn reaction in, 555
 Cerebro-spinal fluid in influenzal meningitis, indol in, 252
 Cerebro-spinal fluid in early syphilis, 223
 Cerebro-spinal fluid in neuro syphilis, provocative reactions in, 288
 Cerebro-spinal meningitis. *See* Meningitis
 Cerebro-spinal syphilis, incidence and treatment of, 406
 Cervical vertebrae, syphilitic disease of, 212
 Cervico-vaginal fistulae, 89, 90
 Cervix, cancer of. *See* Cancer
 Cervix, tuberculosis of, 93
 CHALMERS: *Toxoplasma pyrogenes* Castellani in the Sudan, 70
 CHAMPEAU: Puerperal thrombosis of vagina, 279

Chancere of conjunctiva in a midwife, 126
 Chancere of tonsil associated with Vincent's angina, 678
 Chancres, extragenital, frequency of, 177
 CHAPMAN: Operation for detached retina, 150
 CHABRONNEL: Simple perforating ulcers of caecum and colon, 52—Puerperal thrombosis of vagina, 279
 CHASE: Ectopic pregnancy and rupture into the caecum, 185
 CHATELLIER: Adrenaline in erythromelalgia, 142
 Chest, x-ray examination of in acute respiratory affections in children, 228
 CHIBRAC: Sudden death in fractures of the lower limb, 18
 CHIEVITZ: Surgical treatment of tuberculosis of bones and joints, 598
 Chibbians, treatment of, 134
 Childbirth, maternal mortality in, 391—Continuous ether anaesthesia during, 573
 Child development, influence of forceps on the subsequent physical and mental development of, 96
 CHIRONI: Experimental transplantation of fascia, 718
 Chlorine as a therapeutic agent, 624
 Chloroma in infancy, 264
 Choanae, congenital atresia and occlusion of, 626
 Cholelithiasis, indications for operation in, 212
 Cholera, early diagnosis of, 313
 Cholera infantum, etiological significance of *B. proteus vulgaris* in, 498
 Cholesterol in xanthoma multiplex, 371
 CHRISTENSEN: The different types of pneumococcus, 251
 CHRISTIN: Central neurofibromatosis, 165
 Chrysothrin and psoriasis, 111
 Cicatrices digested with pepsin-hydrochloric acid, 315
 CICCARELLI: Transient acute poliomyelitis in the adult, 37
 Cicutine in treatment of myoclonic encephalitis, 562
 Circulation and heart, changes in due to muscular exercise, 285
 CIVIDALI: Diagnosis of gastro-colic fistula, 14
 CLAP: Treatment of chibbians, 134
 CLARK: Parathyroid tetany in infancy, 42
 CLAUDE: Mental conditions in paralysis agitans, 381
 Claudication, intermittent, treated by diathermy, 207
 CLERC: Cysts of anterior mediastinum, 612
 Olinibacteric radium treatment of haemorrhage at the, 416
 CODA: Perioleucanaemia and malaria, 705
 COFFEY: Implantation of ureter into bowel, 651
 COLE: Antipneumococcus serum, 290
 COLLET: Laryngeal hemiplegia due to gunshot wounds, 442
 Colloidal benzoïn reaction in the cerebro-spinal fluid, 555
 Colloidal gold in septicaemia, 148
 Colloidal gold reaction in general paralysis, 337
 COLLOMB: Tuberculosis of the sclerotic, 11
 Colostorrhoea in pregnancy, 520
 Colostrom, coloured, 364
 Colpotomy, posterior, for puerperal peritonitis, 220
 COIT: Extraction operation for varicose veins, 599
 COMA after injury of frontal lobes, 46
 COMBY: Infantile scurvy, 501
 Complement fixation reaction: In lupus, 131—In surgical tuberculosis, 282
 Complement fixation tests in the hosts of *Bothrioccephalus latus*, 253
 Conjunctival chancere in a midwife, 126
 Conjunctivitis, gonorrhoeal, milk injections in, 465
 CONNELL: Chronic appendicitis, 410
 Consumption. *See* Tuberculosis
 CONTI: Cerebral haemorrhage in childhood, 616
 CORI: Action of intravenous injections of glucose and gum arabic solutions on diabetes, 663
 CORNAZ: Outbreak of tinea tonsurata due to *Microrhizopus lanosum*, 344
 Cornea, ulcer of, 450
 CORNISH: Carcinoma of duodenum, 441
 Corpus esulosum in chronic alcoholism, 225
 COSTA: Semi-symphysisectomy, 690
 COULAND: The cuti reaction during menstruation and after ovariectomy, 688
 COULET: Fatal case of tonsillar abscess, 331
 COUVELAIRE: Retinitis during pregnancy, 578
 COVA: Intravenous injections of mercuric chloride for puerperal fever, 550
 COZZOLINO: Observations on mongolism, 322
 CRABTREE: Extension of renal tuberculosis, 412
 CRAMER: Famine osteomalacia, 88
 CRAMP, stoker's, 318
 CRAMPON: The colloidal benzoïn reaction in the cerebro spinal fluid, 555
 CREXX: Pyelonephritis following pregnancy cured by intravenous injections of urotropine, 156
 CRILE: Mechanism of shock and exhaustion, 198
 CROSS: Staining of phagocytes, 452

CRUICET: Lethargic encephalitis in the Bordeaux region, 346—Prognosis and sequelae of lethargic encephalitis, 623
CRITCHFIELD: Adenoma sebaceum and renal tumours, 398
CUNEO: Perineal hysterectomy, 684
CUNNINGHAM: Reticulated red corpuscles, 236
CURE in treatment of tetanus 674
CURSCHMANN: Laryngeal and pharyngeal crises in influenza, 404
Cutaneous sensitization applications to skin diseases, 694
Cut-reaction during menstruation and after ovariectomy, 688
Cyanosis, chronic, 71
Cyanosis, congenital paroxysmal, 34
Cyancsis, studies in, 394
Cyst, hydatid, cerebral, 56
Cyst, hydatid, of renal pedicle, 57
Cyst of ovary, pedicular torsion in, 31—In association with hydatidiform mole, 155—A physical sign of 249—Caesarean section for obstruction by, 685
Cyst of vagina probably of Wolffian origin, 29
Cystic pyelitis, masked, 682
Cysticercosis, subretinal, 82
Cysts of anterior mediastinum, 612
Cysts, mesenteric, in infancy, 570
Cysts of the anterior part of the nasal fossae, 572
Cysts of the semilunar cartilages, 600
CZEPA: Infective processes in the teeth and internal diseases, 503

D.

Dakin's solution in surgery, 325
DAMADE: Digitalis in treatment of hypertension, 721
DAMENO: Ocular symptoms of lethargic encephalitis, 3
DANIEL: A physical sign of ovarian cyst, 249
DARAGNEZ: Tuberculosis of the cervix, 93
DARGALLO: Modification of Dargallo's stain for elastic fibres, 195
DARGEIN: Relationship between lethargic encephalitis and epidemic hiccough, 622
Spirochaetosis teretolaemorrhagica, 665
DARRIGADE: "Eclampsia" fits in a case of chronic nephritis after decapsulation of kidneys, 661
DAVARIS: Hydatidiform mole in association with ovarian cysts, 155
DAVIES: Cultivation of the gonococcus, 418
DAVIS: Urinary antiseptics 513
Dead grafts for tendon repair, 55
DEBÉDAT: Traumatic optic atrophy, 361
DE BLOEMER: Tuberculin treatment, 138
DEBRAY: Treatment of typhoid spine by vaccines, 543
DE CONCILIS: Bronchiolitis due to irritant gas, 77
DEDICHER: Influence of athletics on the heart, 342
DE FRANCISCO: Statistics of war surgery, 22
DE GAETANO: Chronic pyogenic osteomyelitis, 180
Deglutition disturbance in aortic disease, 45
DE LAROCHE: Familial contagion in lethargic encephalitis, 262
DELBÉZ: Vaccine treatment of empyema, 76
DE LEVIE: Pepsin treatment of ozaena, 114
DELINOTTE: Frequency of extragenital chancres, 177
Deliveries, spontaneous, after Caesarean section, 219
Delivery through a cervical laceration, 248. *See also* Labour
DEL VECCHIO: Colostrorrhoea in pregnancy, 520
DE MARTEL: Acoustic nerve tumours, 439
Dementia praecox and arterio-sclerosis, 78
Demorphization, hyperthermia as a symptom of, 348
DEMOULIN: Hydatid cyst of renal pedicle, 57
DENECHAU: Epidemic encephalitis at Anjou, 135
DENIGÈS: Microchemical test for ammonia, 36
DENK: Etiology and prophylaxis of post-operative jejunal ulcer, 240
Denmark, decline of tuberculosis in, 234
Dental extraction, contraindications to, in cardiopaths, 140
Dentition and fibrile processes, 230
Dentists, occupational dermatitis in, 649
DENYER: Volkmann's contracture, 146
DE RENNIER: Pleurisy with effusion on the "sound" side in artificial pneumothorax, 644
Dermatitis, occupational, in dentists, 649
Dermatitis, reed, 424
DE ROUVILLE: Castration for uterine fibroma, 24
DE STEFANO: Familial spastic paraplegia, 108
Etiological relationship between congenital anomalies and hereditary syphilis, 407
Detachment fractures. See Fractures
DEWEILER: Prophylaxis of hay fever, 401
DEZWARTE: A sign of pregnancy, 414
Diabetes, dietetica or, 1
Diabetes and infections, 158

Diabetes insipidus, pathogeny and treatment of, 105—Pituitary extract and histamin in, 671
Diabetes, islands of Langerhans in, 222
Diabetes mellitus and hirsutism, 50
Diabetes, starvation treatment of, 641
Diabetes and trauma, 484
Diabetics: Can they be allowed to lose flesh? 642
Diathermy, as a lid in empyema, 179—In treatment of intermittent claudication, 207
Diet in typhoid fever, 595
Diethyl-di-allyl-barbiturate of diethylamine, a new anaesthetic, 85
DIFER: Diabetes and trauma, 484
Digitalis in treatment of hypertension, 721
Digitalis and ouabain, 72
Digitalis in therapeutics, tincture and infusion of, 454
DIMMEL: Infective irritation of the bone marrow, 585
Diphtheria, cutaneous and vaginal, 28
Diphtheritic heart. See Heart
Diplegia, cerebral, and Little's disease, 81
Disease, oral symptoms of, 504
Diseases internal, infective processes in the teeth and, 503
Diuresis, action of intravenous injections of glucose and gum arabic solutions on, 603
Diverticula of urinary bladder, 680
Diverticulum, Meckel's, inflammation of, 21
DOETTER: Acquired immunity in influenza, 99
DOUARF: Anterior dislocation of the os maxillare, 541
DOUGLAS: End-results of operation for varicocele, 463
DRJESSEN: Tuberculosis of the female genitals, 66
DRUCK: Malformations of the anus, 655—Radical cure of haemorrhoids, 706
DRJNER: Parathyroid transplantation in post-operation tetany, 580
DRJNAY: Gastric papillomatosis, 130—Primary tumour of pleura, 395
DRUS: Stimulation of appendicitis by acute anterior poliomyelitis, 510
DRURETIL: Glycosuria in pregnancy, 153
The islands of Langerhans in diabetes, 222
Ductus arteriosus, persistent, diagnosis and prognosis of, 405
DUPOTR: Treatment of typhoid spine by vaccines, 543
DURHOT: The colloidal benzoin reaction in the cerebro-spinal fluid, 555
DUMAREST: Pleural effusions in artificial pneumothorax, 476
DUMONT: Meningococcal urethritis, 552
DUNET: Hydatid thrill, 486
Duodenal fluid, normal regurgitation of into the stomach, 203
Duodenal ulcer. See Ulcer
Duodenum, cancer of, 411—Clinical examination of, 539
DUPASQUIER: Prurigo cured by auto-haemotherapy, 534
DUPUYTREN'S contraction 87
DURAND: Dead grafts for tendon repair, 55—Treatment of migraine, 376
DUVAL: Cysts of the anterior mediastinum, 612
Dysentery: Bacteriology of, 395—Treatment of, 701
Dyspeptic symptoms due to chronic appendicitis, 566
Dystocia due to carcinoma of the foetal kidney, 95

E.

Ear, external, syphilis of, 116
Ear, tuberculosis of, 413
EBBLER: Radium treatment of haemorrhage at the climacteric, 416
EBERSON: Dissemination of *Spirochaeta pallida* in experimental syphilis, 338
Echino-coccus disease of the lung and pneumothorax treatment, 357
Eclampsia: Prognosis of, 183—Source of the toxin of, 548
"Eclampsia" fits in a case of chronic nephritis after decapsulation of kidneys, 661
Eczema, protein sensitization in, 164
EDELMANN: A sign of cerebro-spinal meningitis, 430
EISELSBERG: Statistics of gastric and duodenal ulcer, 652
EISLER: Vertebral osteomalacia, 656
Elastic fibres, modification of Dargallo's stain for, 196
ELDER: Treatment of orchitis in mumps, 119
Electro-cardiograph, 536
ELGART: Vaginal preparation for extended hysterectomy, 27
ELIZALDE: Gummata of the lung, 250
ELY: Encephalitis lethargica, 587
EMGE: Varicose veins of female pelvis, 277
Empyæma, subcutaneous, in measles, 379
Empyæma, diathermy and aird in, 179
Empyæma, tuberculous, treatment of, 436
Empyæma, vaccine treatment of, 76
Encephalitis, epidemic. At Anjou, 136—Ocular manifestations of, 514—Atypical, 667—A peculiar mental syndrome following, 668—Prolonged mental forms of, 670

Encephalitis lethargica, 586, 587, 588—In Switzerland, 236
In the Bordeaux region, 346—Of long duration, 669
Encephalitis lethargica in children, 200
Encephalitis lethargica, experimental, 420
Encephalitis lethargica, familial contagion in, 392
Encephalitis lethargica, relation of to epidemic hiccough, 622
Encephalitis lethargica, relation of to influenza, 476
Encephalitis lethargica, insomnia as a sequel of, 433
Encephalitis lethargica, morbid anatomy of, 366
Encephalitis lethargica, ocular symptoms in, 3
Encephalitis lethargica, prognosis and sequelae of, 623
Encephalitis lethargica in Switzerland, 236
Encephalitis, myoclonic, treated by cicutine, 562
Endocarditis, acute, in children, 373
Endocervicitis, chronic, a study of, 446
Endocrine glands, radiotherapy of, 429
ENGELHARD: Chronic trophoedema and spicula in the acicula, 20
ENGLERENS: Influence of forceps on the subsequent physical and mental development of the child, 95
ENGMAN: Application of cutaneous sensitization to diseases of the skin, 694
Enterostomy for post-operative ileus, 676
Eosinophilia in scabies, 283
Epilepsy: Date of onset of, 377
Removal of suprapurulent capsules for, 435
Epithelioma: Arising in lupus erythematosus, 424—Following x-ray treatment for tuberculosis of knee, 695
ERATH: Vaccine treatment in otorhinolaryngology, 243
Erectile tissue, gangrene of, 387
Erysipelas treated by injections of novocain and adrenaline, 621
Erythrocytes, sedimentation velocity of during pregnancy, 609
Erythromelalgia, adrenaline in, 142
ESMANN: Gabaston's method for removal of the placenta, 603
Ether anaesthesia, continuous, during childbirth, 573
Exhaustion and shock, mechanism of, 198
EXNER: Effect of injections of sugar on anaesthesia, 327
Eye diseases, universal light baths in, 215

F.

Facial paralysis. See Paralysis
FAGGIOLI: Irradiation of the hypophysis in bronchial asthma, 169
Fallopian tube, the virgin, torsion of, 736
Fallopian tubes, gland tubules in, 187
FANTOZZI: Acute osteomyelitis of the ribs, 271
FANZIO: Vaccine therapy in typhoid, 261
FASCIA, experimental transplantation of, 718
FAYREAU: Puerperal thrombosis of vagina, 279
FAY: Eosinophilia in scabies, 283
Feet, paralytic, removal of astragalus in, 86
FELDMAN: The plantar reflex in early life, 557
FELDMANN: Consecutive bilateral artificial pneumothorax, 139
FELICANGELLI: Ludwig's angina in a haemophilic subject, 359
Femur, obstetrical fracture of, 60. *See also* Fracture
Fever following abortion, treatment of, 467, 519
Fever, cerebro-spinal, complicated by hydrocephalus, 615
Fever, enteric, the diet in, 595
Fever, enteric, intestinal perforation in, in childhood, 51
Fever, enteric, perforation in, 378
Fever, enteric, vaccine treatment of, 166, 261
Fever, enteric, Weiss's reaction in, 69
Fever of infancy, a peculiar, 618
Fever, Malta, masticis in, 50
Fever, paratyphoid B, false perforation in, 79
Fever, rat bite, 319
Fever, scarlet: Prevalence of, 590—Schultz-Charlton test for, 591
Fever, typhus, histology of the eruption in, 64
Fever, typhus, surgical complications of, 301
Fibroid operations, statistics of, 190
Fibroids of uterus: Treatment of, 335—Complicating pregnancy, 491
Fibroma, uterine, castration for, 24
Fibromyoma of the urethra, 607
FIESSINGER: Spirochaetes in the urine in secondary syphilis, 397
FILIPPINI: Diabetics of diabetes, 1
FINSTERR: End-results of the operative treatment of duodenal ulcer, 210
FISHERING: Intrathoracic neoplasms, 675
Fistula, gastro-colic, diagnosis of, 14
***Fistula, vesico-uterine,** 61
Fistula, vesico-vaginal, transvesical operations for, 521

- Fistulae, cervico-vaginal, 89, 90 Oesophago-tracheal, 640
- FITZ: Acute nitro benzol poisoning, 723
- FLAMINA: Hydrops foetus universalis, 26
- PLATAU: Operation for sterilization, 575
- FOETAL hydrops universalis, diagnosis of, 280
- FOETUS, loose, in abdominal cavity for five years, 189
- FOGGIN: Peripheral neuritis occurring in pregnancy, 549
- FOOD-BLOCK, fatal asphyxia from, 274
- FOURCEPS, influence of on the subsequent physical and mental development of the child, 96
- FOREIGN body in the heart, 440
- FOSSATI: Treatment of pulmonary tuberculosis by artificial pneumothorax, 209—Haemoclastic crisis as evidence of hepatic impairment, 717
- FOTT: Treatment of leishmaniasis, 700
- FOUCADE: Gpotherapy and the menopause, 605
- FOWLER: Renal decapsulation in subacute nephritis 427—Gastric syphilis, 653
- Fracture of femur, obstetrical, 60
- Fractured ribs, artificial pneumothorax in, 329
- Fractures of os calcanei, direct, 729
- Fractures, compression, of vertebrae, 299
- Fractures, detachment, following strain, 113
- Fractures, delayed union in, 544
- Fractures of lower limbs, sudden death in, 18
- Fractures, non union following, 731
- Fractures of the lower end of the radius, 489
- Fractures of scapula, incomplete, 728
- Fractures of spongy bones, treatment of, 597
- Fractures, treatment of, 354
- Fragilitas ossium, 639
- FRANCIANI: A peculiar mental syndrome following epidemic encephalitis, 668
- FRANÇOIS: Pyelonephritis following pregnancy cured by intravenous injections of urotropine, 156
- FRANZ: Acidental haemorrhage, 659
- FRANZER: Renal decapsulation in subacute nephritis, 427
- FRICKE: Use of pessaries, 443
- FRIED: Complement fixation reaction in lupus, 131—A rapid sero-diagnostic method in tuberculosis, 159—Complement deviation in surgical tuberculosis, 282
- FRIEDBERG: Turpentine injections for gynaecological infections, 447
- FRIEDMAN: The pituitary in Graves's disease and myxoedema, 593—Retropharyngeal abscess, 677
- Friedmann's tuberculosis vaccine, effects of, 479, 480
- FROHM: The renal test meal, 508
- FROME: Etiology of Calvé-Perthes's disease, 554
- Frontal lobes, coma after injury of, 46
- FRÜHWALD: Presence of spirochaetes in lymphatic glands, 103
- FUA: Melæna neonatorum treated with horse serum, 265
- FUMAROLA: Tumours of the auditory nerve, 526
- Furuncle of lip, treatment of, 49
- G.
- Gabsston's method in detachment of the placenta, 154, 603
- GÄHWYLER: Non-tuberculous inflammation of the bronchial glands, 648
- Galactorrhoea, unusual case of, 278
- GALAMBOS: Barium sulphate in the treatment of gastric and duodenal ulcer, 702
- Gall bladder, torsion of, 712
- Gall stones causing intestinal obstruction, 118
- GALLOIS: Permanganate of silver in the treatment of urinary diseases, 631
- Galvano-cauterization, laryngeal tuberculosis cured by, 213
- GAMRAT: Xanthoma multiplex, 451
- Gangrene of erectile tissue, 387
- GARDNER: Methyl alcohol poisoning, 347
- GARGIULO: Roughness of the skin in tuberculous subjects, 237
- Gaa, irritant, bronchiolitis due to, 77
- GASTINEL: Blood cultures in bubonic plague, 399
- Gastric papillomatosis, 130
- Gastric syphilis, 653
- Gastric ulcer. See Ulcer
- Gastro colic fistula. See Fistula
- Gastro enterostomy followed by ulcer of jejunum, 353
- GATE: A new serum reaction in syphilis, 98—Prurigo cured by auto-haemotherapy, 534
- GATES: Filtrable bodies in influenza, 472
- GAUTHIER: Renal calculi in soldiers, 385
- GAYARD: Treatment of typhoid spine by vaccines, 543
- GEJROT, W.: Detachment of the placenta by Caboston's method, 154—Prognostic sign of the escape of meconium, 246
- GELLER: Experimental exposure of the genitalia, female tuberculosis of, 66
- Genitals, male, tuberculosis of, 462
- GENOISE: Treatment of whooping-cough, 314
- GERARD: Conjunctival chancre in a midwife, 126
- GESSNER: Source of the toxin of eclampsia, 548
- Gestation, ectopic, 307
- Gestation, tubal, etiology of, 735
- Gestation. See also Pregnancy
- GIBSON: Pituitary extract and histamin in diabetes insipidus, 671
- GIESECKE: Carcinoma vulvae, 495
- GIFFIN: Treatment of pernicious anaemia by splenectomy, 403
- GIGNOUX: Cysts of the anterior part of the nasal fossae, 572
- GILL: Stoffel's operation for spastic paralysis, 488
- GINESTOUS: Traumatic optic atrophy, 361
- GIORG: Epidemic of Barlow's disease, 343
- GIOSEFFI: Intestinal perforation in typhoid in childhood, 51—Vaccination in country districts, 458
- GIROUX: Rate of propagation of the arterial pulse-wave, 720
- GIFFRÉ: Bronchial asthma, 133
- Gland tubules in the Fallopiian tubes, 187
- Glands, bronchial, non-tuberculous inflammation in, 648
- Glands, endocrine, radiotherapy of, 429
- Glands, lymphatic, presence of spirochaetes in, 103
- Glands, sex, transplantation of, 326
- Glioma of the nasal fossae, 19
- Glucose solutions, action of intravenous injections of on diuresis, 663
- Glyco-uria: In pregnancy, 153—In infants, 287—Renal, 339
- Goitre, etiology of, 224. See also Graves's disease
- GOLAY: Jaundice following injection of salvarsan in non-syphilitic cases, 499
- Gold, colloidal: In septicæmia, 148—In general paralysis, 337
- GOLDENBERG: Complement fixation reaction in lupus, 131—A rapid sero-diagnostic method in tuberculosis, 159
- GOLDENER: Distension of lower uterine segments with unruptured membranes, 127
- GOLDSCHMIDT: Ventrofixation of vagina, 577
- GOLDSTEIN: Telangiectasia, 351—Pyelography and uteriography, 732
- Gonococcus, are there several strains of? 227—Cultivation of, 411
- Gonorrhoea: Acriflavine irrigation in, 512—Vaccine therapy of, 511
- Gonorrhoeal conjunctivitis, milk injections in, 465
- Gonorrhoeal peritonitis, 13
- GONZÁLES: Placenta praevia, 392—Auto vaccination for acute suppurative otitis media, 571
- GOY: Oesophago-tracheal fistulae, 640
- GOVAERTS: Arsenical paralysis due to neo-salvarsan, 73—Surgical narcosis, 602
- GRAD: Ectopic gestation, 307—Subperitoneal shortening of round ligaments, 493
- GRAM: Physiological anaemia of pregnancy, 218—Blood platelet enumeration, 336—Relation between haemoglobin and number of blood cells, 497
- GRAMEN: Wildbolz's auto-urine reaction in tuberculosis, 195
- GRANDJEAN, E.: Blood pressure of aviators, 2
- GRAPPIOLO: Treatment of pulmonary tuberculosis by artificial pneumothorax, 209
- GRASMANN: Cervico-vaginal fistulae, 90
- GRASS: Effects of Friedmann's tuberculosis vaccine, 479
- GRAVES: Extended hysterectomy after radium treatment of cancer of cervix, 128
- Graves's disease, the pituitary in, 593. See also Goitre
- GREENFIELD: Retropharyngeal abscess, 677
- GRENTBAL: Glycosuria in infants, 287
- GRIESTER: Etiology of tubal gestation, 735
- GRÖNBERG: Blood ferments in pregnancy, carcinomas, and pulmonary tuberculosis, 254
- GROSS: Alveolectomy, 569
- GROSSE: Three spontaneous deliveries after Caesarean section, 219
- GRULEE: A peculiar fever of infancy, 618
- GRÜNDAUM: Treatment of intermittent claudication by diathermy, 207
- GRUNDFEST: Saccharin intoxication, 704
- GRYZEJ: New method of facilitating detection of tubercle bacilli, 368
- GUIRE: Luxations of the thumb, 144
- GUILHÉ: Spirochaetes in the urine in secondary syphilis, 397
- Gum arabic solutions, action of intravenous injections of on diuresis, 663
- Gummata of the lung, 250
- Gunshot wounds, laryngeal hemiplegia due to, 442
- Gunshot wounds of the mastoid, 438
- Gynaecological infections, turpentine injections for, 447
- H.
- HAAS: Vertebral osteomalacia, 656
- Haematomatous renal infection, 160
- Haematotoma of the abdominal wall, spontaneous, 492
- Haemoclastic crisis as evidence of hepatic impairment, 717
- Haemoglobin and the number of blood cells, relation between, 497
- Haemoglobinuria after a second blood transfusion with same donor, 716
- Haemoglobinuria, paroxysmal, auto-sphyxiasis in, 500
- Haemolytic jaundice, 453
- Haemophilic subject, Ludwig's angina in, 359
- Haemoptysis and the action of camphor, 352
- Haemorrhage, accidental, 659
- Haemorrhage, autotransfusion for, 273
- Haemorrhage, cerebral, in childhood, 616
- Haemorrhage at the clunsteric, radium treatment of, 416
- Haemorrhage, intracranial, treatment in the newborn, 297
- Haemorrhage caused by small mucous polyp of the corpus uteri, 574
- Haemorrhoids, radical cure of, 706
- HAGLER: Dissecting abscess of the caecal wall, 147
- HAGUENAU: Colloidal gold reaction in general paralysis, 337
- HAIJOS: Meinicke and Sachs-Georgi reactions, 132
- HALBAN: Treatment of fever following abortion, 519
- HALLERSON: Chlorine as a therapeutic agent, 624
- HALLISEY: Studies in properties of blood platelets, 393
- Hallux valgus, rigidus, and malleus, 730
- HAMANT: Pain in the left side in appendicitis, 437
- HANAK: Intestinal obstruction and tubal pregnancy, 184
- HANKE: Properties of histidin, 35
- HANSEN: Strychnine in post-operative atony of the stomach, 84—Streptococcal serum in pyaemia, 202—Spontaneous rupture of the bladder, 707—Torsion of gall bladder, 712
- HANSEN: Incidence and treatment of cerebrospinal syphilis, 406
- HARBITZ: Curability of tuberculous meningitis, 482
- HARDISTY: Diagnosis of gastric ulcer, 386
- HARRIS: Determination of blood volume, 197
- HARVIE: Experimental encephalitis lethargica, 420
- HASKELL: Methyl alcohol poisoning, 347
- HASSIN: Atypical epidemic encephalitis, 667
- HASTRUP: Intestinal obstruction after ventrofixation of the uterus, 216
- HATCHER: Tincture and infusion of digitalis in therapeutics, 454
- HAUCH: Incubation-chamber treatment of premature or very small infants, 58
- HAY fever, prophylaxis of, 401
- HAYMAN: Eosinophilia in scabies, 283
- Heart and circulation, changes in due to muscular exercise, 285
- Heart, diathermic, treatment of, 107
- Heart disease in pregnancy and puerperium, 634
- Heart disease, quinidine in, 620
- Heart, foreign body in, 440
- Heart, influence of athletics on, 342
- Heart. See also Auricular and Cardiac
- HEIDENHAIN: Indications for operation in cholelithiasis, 242
- HEIL: Torsion of the virgin Fallopiian tube, 736
- HEINRICHSDORFF: Unusual case of urethral stricture, 124
- HEISS, V.: Delivery through a cervical laceration, 248
- Heliotherapy in secondary syphilis, 75
- Hemiplegia, blood pressure and oedema in, 286
- Hemiplegia, laryngeal, due to gunshot wounds, 442
- Hepatic impairment, haemoclastic crises as evidence of, 717
- Hepatic and renal functions, action of spinal anaesthesia on, 710
- Hepatitis and nephritis secondary to round ulcer of stomach, 740
- Herbivora, *B. tetani* in the digestive tract of, 695
- HERMANS: Vaccine therapy of gonorrhoea, 511
- Hernia of linea alba, 487
- Herpes of the anal region, with meningeal symptoms, 459
- Herpes ophthalmicus, 149
- Herpes zoster, adenitis in, 6
- Herpes zoster as the only sign of latent disease, 323
- Herpetic keratitis, human, transmissibility of to the rabbit's cornea, 692
- HERTZ: Importance of Wassermann's reaction in institutions for scrofula, 13
- HEUYER: Persistent vomiting of pregnancy, 517
- Hiccough, epidemic, 431—At Rheims, 135—Relationship between lethargic encephalitis and, 622
- Hiccough, persistent, treatment of, 201
- HIES: Accidental haemorrhage, 659
- HILFMAN: Methyl alcohol poisoning, 347
- HILLIS: Treatment of septic abortion, 191
- HILDE-NIELSEN: Nitro benzol poisoning treated by blood transfusion, 109
- Hip, long-standing dislocations of, 120
- HIRSCH: Diathermy an aid in empyema, 179
- Hirsutism and diabetes mellitus, 529
- Histamin and pituitary extract in diabetes insipidus, 671
- Histidin, properties of, 35

HITZENBERGER: The metabolism in vascular hypertonus, 527
 HIZBROT: Fractures of the lower end of the radius, 489
 HÖGLER: Diagnosis of neuro-myositis, 530—Aneurysms of the cystic and splenic arteries, 614
 HOLDEN: Ocular manifestations of epidemic encephalitis, 514
 HOLMES: Auiyotonia congenita, 129
 HOLMGREN and HOLST: Neo-salvarsan in putrid bronchitis, 483
 HORNING: Operations for myoma, 415—Air embolus after criminal abortion, 714
 HORSE serum. *See* Serum
 HORSLEY: Ulcer of jejunum following gastro-entrostomy, 353
 HOUPST: Epidemic hiccough, 431
 HOWELL, Katherine: Failure of antibody formation in leukaemia, 367
 HOWK: Small-pox and tuberculosis, 137
 HRUSKA: Serum diagnosis of tuberculosis of cattle, 419
 HUBER: Spirochaetes in the urine in secondary syphilis, 397
 HUNTINGDON: Acute inversion of uterus, 660
 Hydatid cyst, cerebral, 55
 Hydatid cyst of renal pedicle, 57
 Hydatid disease: Diagnosis of, 350—Intra-dermo and subcutaneous reactions in, 474—The intradermo reaction in the diagnosis of, 496
 Hydatid thrill, 486
 Hydatidiform mole, unusual case of, 94—In association with ovarian cysts, 155
 Hydrocele in children, 540
 Hydrocephalic form of cerebro spinal meningitis in infants, 502
 Hydrocephalus complicating cerebro-spinal fever, 615
 Hydrops foetus universalis, 26—Diagnosis of, 280
 Hypertemesis gravidarum, treatment of, 247
 Hypertension, digitalis in treatment of, 721
 Hypertension in chronic nephritis and arterio-sclerosis 68
 Hypertension, primary, 611
 Hyperthermia as a symptom of demorphiaization, 348
 Hyperthyroidism, 428—X-ray therapy in, 592
 Hypertonus, vascular, the metabolism in, 527
 Hypertrophic stenosis of the pylorus, 625
 Hypophysis, irradiation of in bronchial asthma, 169
 Hysterectomy, abdominal, for puerperal infections, 92
 Hysterectomy for cancer of cervix, late results of, 390
 Hysterotomy, extended, vaginal preparation for, 27
 Hysterectomy, extended, after radium treatment of cancer of cervix, 128
 Hysterectomy, perineal, 684

I.

ICHOK: Complement fixation reaction in lupus, 131
 Heus, post-operative, enterostomy for, 676
 IMBERT: Operation for complete perineal tear, 59
 Incubation, chamber treatment of premature or very small infants, 58
 INDEMAN: Diagnosis of appendicitis, 272
 Indol in cerebro-spinal fluid in influenzal meningitis, 252
 Infancy, a peculiar fever of, 618
 Infant mortality and premature births, 471
 Infants, acute arthritis in, 507
 Infants, newborn: Treatment of intracranial haemorrhage in, 237—Syphilitic contagion of, 321—Concentration of blood, fever and loss of weight in, 506
 Infants, premature or very small, incubation-chamber treatment of, 58
 Infants, pseudo-leukaemic splenicaemia in, 643
 Infants, solid food for, 324
 Infectious diseases, the residual nitrogen in, 703
 Influenza in 1918-20, bacteriology of, 67
 Influenza, bronchiectasis after, 260
 Influenza, acquired immunity in, 99
 Influenza, relation of to encephalitis lethargica 456
 Influenza, filtrable bodies in, 472
 Influenza, laryngeal and pharyngeal crises in, 404
 Influenza, pneumococci and streptococci in, 697
 Influenza followed by polyneuritis, 589
 Influenza, pulmonary, in children, 460
 Influenza, skin eruptions in, 9
 Influenza statistics, 294
 Influenzal meningitis, indol in cerebro-spinal fluid in, 252
 Influenzal pneumonia treated with serum from convalescents, 8
 INGEBRIGTSEN, R.: Physiology of wound repair, 175
 Insomnia in children, 594
 Insomnia as a sequel of lethargic encephalitis, 433
 Internal disease. *See* Disease
 Interstitial keratitis. *See* Keratitis

Intestinal di-cocci, anaerobic flora in, 195
 Intestinal miasa, bactericidal power of, 551
 Intestinal obstruction due to gall stones, 118
 Intestinal obstruction, intermittent, caused by Murphy's button, 151
 Intestinal obstruction and peritonitis in pregnancy, labour, and the puerperium, 152
 Intestinal obstruction and tubal pregnancy, 184
 Intestinal obstruction after ventrofixation of uterus, 216
 Intestinal perforation in typhoid in childhood, 51
 Intestinal stasis, chronic, 300
 Intestinal tuberculosis. *See* Tuberculosis
 Intestine, small, complete occlusion of, 53
 Intraperitoneal infusion in adults, 709
 Intrathoracic neoplasms, 675
 Intrauterine therapy for uterine infection, 91
 Intravenous injections, tourniquet for, 733
 Iodine powder as a substitute for tincture of iodine, 683
 IZARD: Myasthenia gravis with osseous changes, 173

J.

JACOBARI: Treatment of influenzal pneumonia with serum from convalescents, 8
 JACOBS: Early recognition of uterine cancer, 97
 JACOBSON: Reduction of nervous irritability, 719
 JACQUELIN: Hepatitis and nephritis secondary to round ulcer of stomach, 740
 JAFFÉ: Myocardial tuberculosis, 726
 JAMES: Prognosis of nephritis in childhood, 400
 JANSEN: Hallux valgus, rigidus, and malleus, 730
 JAPIOT: X-ray treatment of interstitial keratitis, 679
 JAQUEROD: Duration of artificial pneumothorax, 645
 JARNO: Nodular regurgitation of duodenal fluid into the stomach, 203
 Jaundice following injection of salvarsan in non-syphilitic cases, 499
 Jaundice, haemolytic, 453
 Jaundiced persons, the peculiar odour of, 535
 JAVARONK: Treatment of leishmaniasis, 700
 Jejunal ulcer. *See* Ulcer
 JEMMA: Septic infections of the urinary passages in children, 171
 JENNY: Quinidine in heart disease, 620
 JENSEN: Decline of tuberculosis in Denmark, 734—Picrocaranine staining of sections, 524
 JOHNSON: Acute arthritis in infants, 507
 Joints and bones, surgical treatment of tuberculosis of, 598
 JOLLY: Lymphoid cells in the blood in acute leukaemia, 473
 JONSSON: Aneurysm of the hepatic artery, 211
 JUNGANO: Primary tuberculosis of the bladder, 12

K.

KAFKA: Diagnosis of foetal hydrops universalis, 280
 KAISER: Bilateral testicular sarcoma, 450
 KAMAR: *Toxoplasma pyrogenes Castellani* in the Sudan, 70
 KARSTROM: Paralytic vaccination, 559
 KATZ: Unusual mechanism of labour in placenta praevia, 123
 KEERSMAEKERS: Treatment of dysentery, 701
 KELLY: Use of pessaries, 443
 Keloids, digestion of with pepsin-hydrochloric acid, 315
 KENDE: Sarcoma of the uterus, 63
 KEPPICH: Experimental production of gastric ulcer, 637
 Keratitis, human herpetic, transmissibility of to the rabbit's cornea, 692
 Keratitis, interstitial, x-ray treatment of, 679
 Keratitis, parenchymatous, and trauma, 711
 KERL: Syphilitic polyneuritis, 145
 KHARMA-MARINOFF: Vaccine treatment of typhoid fever, 166
 KICHEM: Rupture of uterus at Caesarean sect., 188
 Kidney, experiments on temporary exclusion of, 275
 Kidney, pelvic, mistaken for haematometra, 192
 KILNER: Zinc chlorid poisoning, 722
 KILBASSA: Pedicular torsion in ovarian cysts, 31
 KIRSCHNER: Bacteriology of dysentery, 396
 KJAER: Serum treatment of meningococcal septicaemia, 170
 KJAERGAARD: Epithelioma following x-ray treatment for tuberculous of knee, 693
 KLAUDER: Provocative reactions in the cerebro-spinal fluid in neuro-syphilis, 258
 KLEEMANN: Primary carcinoma of the vagina, 365
 KLEIN: Polyneuritis following influenza, 589
 KLESSENS: Date and onset of epilepsy 377
 KLINKERT: Sarcoma of the stomach, 610
 Knee-joint, loose bodies in, 568

Knee, tuberculosis of. *See* Tuberculosis
 KOESSLER: Properties of histidin, 35
 KÖHLER: Intestinal obstruction and peritonitis in pregnancy, labour, and the puerperium, 152
 Köhler's disease, thyroid extract in, 531
 KOLMER: Histological changes produced by salvarsan, 161
 KONDOLEON: Breast enlargement after prostaticectomy, 304
 KONINGS: Treatment of persistent hiccough, 201
 KOTZAREFF: Premature separation of the normally situated placenta, 25
 KRAC-MOLLER: Intestinal tuberculosis and the anaemia of consumptives, 455
 KROGITS, Ali: Dupuytren's contraction, 87
 KULENKAMPFF: Treatment of the excitement stage of anaesthesia, 564
 KUMER: An unusual case of sarcoma, 257
 KURTZ: Alimentary amenorrhoea, 445
 KYLAN: The capillary pressure, 239

L.

Labial commissures, symmetrical tuberculous ulceration of, 596
 Labour: Breech presentation, management of, 333
 Labour: Delivery through a cervical laceration, 248
 Labour, continuous ether narcotization during, 573
 Labour, intestinal obstruction and peritonitis in, 152
 Labour, maternal mortality in, 391
 Labour, management of after previous Caesarean section, 417
 Labour normal, delivery by version in, 604
 Labour, premature, and abortion, causes of, 635
 Labour obstructed by fixation of retroverted uterus, 491
 Labour: Spontaneous deliveries after Caesarean section, 219
 LAFFORGUE: Pneumococcal septicaemia, 727
 LAIGNEL-LAVASTINE: The corpus callosum in chronic alcoholism, 225
 LANDAUER: Treatment of surgical tuberculosis with partial antigens, 538
 LANDE: Ambulatory treatment of varicose ulcers, 199
 LANE: Occupational dermatitis in dentists, 649
 Langshans, islands of, in diabetes, 222
 LANGERON: Congenital paroxysmal cyanosis, 34
 LANNONIS: Gunshot wounds of the mastoid, 438
 LANZ: Treatment of furuncle of lip, 49
 Laryngeal cancer. *See* Cancer
 Laryngeal crises in influenza. *See* Influenza
 Laryngeal hemiplegia. *See* Hemiplegia
 Laryngeal nerve. *See* Nerve
 Laryngeal stridor, congenital, pathology of, 101
 Laryngeal tuberculosis. *See* Tuberculosis
 Laryngeal ventricle, eversion of the mucosa of, 545
 Larynx, angiomata of, 332
 Larynx, acute primary perichondritis of, 81
 LATZKO: Treatment of fever following abortion, 519
 LAUBRY: Rate of propagation of the arterial pulse wave, 720
 LAUDA: Transmissibility of human herpetic keratitis to the rabbit's cornea, 692
 Lavage, pelvic, in treatment of pyelitis of pregnancy, 689
 LAVEDAN: Lymphoid cells in the blood in acute leukaemia, 473
 LAVIELLE: Acute primary perichondritis of the larynx, 81
 LAWSON: Small-pox and tuberculosis, 137
 LAY: Colloidal gold in septicaemia, 148
 LAZARIDES: Vaginal cyst probably of Wolffian origin, 29
 Lead workers, blood changes in, 475
 LEBEL: Adenitis in herpes zoster, 6
 LEDERER: Treatment of whooping cough, 74
 LEDFORD: Acute endocarditis in children, 373
 LEFORT: Brain abscess following wounds, 328
 LE GRAND: Obstetrical fracture of femur, 60
 LEHMANN: Inflammation of Meckel's diverticulum, 21
 LEICHTENTRITT: Pulmonary influenza in children, 460
 LEIMBÖRGER: Skin eruptions in influenza, 9
 Leishmaniasis, treatment of, 700
 LE JEMTEL: Abdominal hysterectomy for puerperal infections, 92
 LEMONE: Treatment of anaemia by nucleinate of manganese, 298—Relationship between lethargic encephalitis and epidemic hiccough, 622
 LENDERTZ: Vaginal and cutaneous diphtheria, 28
 LE NOIR: Hepatitis and nephritis secondary to round ulcer of stomach, 740
 LEIBOUCKET: Myasthenia gravis with osseous changes, 173
 LERI: Chronic trophoedema and spina bifida occulta, 20

- LERICHE:** Fate of transplanted bone, 408
LEIMOVYZ: Tuberculosis of ear, 413
Lethargic encephalitis. *See* Encephalitis
Leucocytes, neutrophilic, in pulmonary tuber-
culosis, 255
Leucocytic ferments, extraction of, 340
Leucorrhoea, pathology and treatment of, 713
Leukaemia, acute, 528—Lymphoid cells in the
blood in, 473
Leukaemia, failure of antibody formation in,
367
LEVADITI: Experimental encephalitis lath-
 argica, 420
LEVINSON: The Sachs-Georgi reaction, 581
LEVINSON: Xanthochromia, 194—Neuro-
 cephalitis simulating paralysis agitans, 699
LEVY: Bronchopulmonary spirochaetosis
 (Osstellau), 375
LEVY: Spirochaetes in the urine in secondary
 syphilis 397
LEVY-FRANCKEL: Splenomegaly, due to
 arsenobenzol, 269
LIEBERMITE: Regeneration of peripheral
 nerves, 739
LICHT, De Fine: Dakin's solution in surgery,
 326
LICHTENSTERN: Transplantation of testes in
 man, 356
LIE: Arterio sclerosis and dementia praecox,
 78
Ligaments, round, insertions and diagnosis
of impending rupture of the uterus, 23—
Subperitoneal shortening of, 493
Light baths, universal, in diseases of the eyes,
215
LINDBERG: Traumatic serous meningitis in
 childhood 355
LINDBLAD: Injections of milk in gonorrhoeal
 conjunctivitis, 465
LINDSTEDT: Predisposing causes of sciatica,
 374
Linnaea alba, hernia of, 487
Lip, furuncle of treatment of, 49
Little's disease and cerebral diplegia, 80
LITZENBERG: Missed abortion, 468
Liver, central rupture of, 330
LOBEL: Amyloid disease of the lung, 556
LOBE: Acute nitrobenzol poisoning, 723
LOEWENHART: Intraperitoneal infusion in
 adults, 709
LOGAN: Pneumococci and streptococci in
 influenza, 597
LOMHOLT: Syphilitic contagion of the new-
 born, 321
LOVE: Autotransfusion for haemorrhage, 273
LOWENBERG: Solid food for infants, 324
LOWY: Infective irritation of the bone
 marrow, 585
LUCKE: Histological changes produced in
 salivary gland, 161
Lu Lwif's angina. *See* Angina
Lukaemia, myeloid, treated with benzol, 432
LUKOWSKI: Haemolytic jaundice, 453
LUGER: Paravertebral dullness in carcinoma
 of oesophagus, 627—Transmissibility of
 human herpetic keratitis to the rabbit's
 cornea, 692
Lumbal anaesthesia, 461
Lumbar puncture and meningitis, 104
LUNA: Vaccine treatment of typhoid fever, 166
LUND: Syphilis of the external ear, 116—
 Ostitis mastoidea zygomatica, 284
LUNDBORG: Tuberculosis and heredity, 258
LUNDEGAARD: Universal light baths in
 diseases of the eye, 215—Studies in cyanosis,
 394
Lung, amyloid disease of, 556
Lung, echinococcus disease of, and pneumo-
thorax treatment, 357
Lung, gummata of, 250
Lungs, Caesarean section in acute oedema of,
715
Lupus, complement fixation reaction in, 131
Lupus erythematosus, epithelioma arising in,
424
Lupus vulgaris, distribution of, 268
LURDIANA: Diagnosis of hydatid disease, 350
LUSSANA: Subcutaneous oedema and sero-
 fibrinous pleurisy, 509
LUZZATI: Unusual case of galactorrhoea, 278
LYDSTON: Transplantation of sex glands, 326
Lymphatic glands. *See* Glands
Lymphoid cells in the blood in acute leuk-
aemia, 473
- M.
- MACCABRINI:** Sedimentation velocity of
 erythrocytes during pregnancy, 609
McCLURE: The control of the pyloric sphincter
 in man, 17
McCord: Zinc chloride poisoning, 722
McGUIRE: Carcinoma of duodenum, 441
McPECK: Unusual case of mercuric chloride
 poisoning, 5
MADSEN: Stoker's cramp, 318
Malaria caused by injection of human serum,
112
Malaria and pernicious anaemia, 705
Malaria, rupture of spleen in, 263
Malta fever. *See* Fever
Mammary hypertrophy treated by sub-
cutaneous injection of milk, 16
MAMONE: Haemoclastic crisis as evidence of
 hepatic impairment, 717
MANCINI: Pseudo-leukaemic splenic anaemia
 in infants, 613
MANDELBAUM: Tuberculous meningitis, 316
MANDELKIN: Syphilitic placenta, 469
Manducase, nucleotide of, in treatment of
anaemia, 298
MANN: Acriflavine irrigation in gonorrhoea,
 512
MANFELD: Treatment of menorrhagia, 221
MANTELLI: Sapheno-femoral anastomosis,
 411
Mantoux's intradermo reaction in infantile
tuberculosis, 158
MARAGLIANO: Obstetric paralysis of the arm,
 606
MARAÑÓN: The diet in typhoid fever, 595
MARCHAND: Histological lesions in a case of
 rabies, 423
MARCIAGIS: Case of syphilitic aortitis, 40
MARIE: Treatment of myoclonic encephalitis
 by eucytine, 562—Opoththerapy and the men-
 opause, 605
MARION: Transvesical operations for vesico-
 vaginal fistula, 521
MARSAUDON: Prognosis of eclampsia, 183
MARTIN: Smoking and mental activity, 110—
 Pituitary extract and histamin in diabetes
 insipidus, 671
MASSARI: Rupture of spleen in malaria, 263
Mastitis in Malta fever, 50
Mastitis, syphilitic, 654
Mastoid abscess. *See* Abscess
Mastoid, gunshot wounds of, 438
Mastoiditis and Pott's disease, 389
Maternal mortality in childbirth, 391
MATHEW, Porter: Retrospect of four thousand
 obstetric cases, 305
MATHEWS: Study of chronic endocervicitis,
 446
MAXWELL: Calcified tubal mole, 125
MAYER: Lethargic encephalitis in Switzerland,
 235—Division of the superior laryngeal nerve
 in laryngeal phthisis, 276
Measles, subcutaneous emphysema in, 379
Measles exanthem, histology of, 310
Meckel's diverticulum, inflammation of, 21
Meconium, prognostic significance of the
escape of, 246
Mediastinum, anterior, cysts of, 612
MERTENS: Rectal injection of massive doses
 of neo-arsphenamin, 601
Meinicke and Sachs-Georgi reactions, 132
Melaena neonatorum treated with horse serum,
265
Meningeal symptoms in herpes of the anal
region, 459
Meningitis, acute and tuberculous, 289
Meningitis, cerebro-spinal, purpura in, 106—
A sign of, 430—Hydrocephalic form of in
infants, 502
Meningitis, influenza, indol in cerebro spinal
fluid in, 252
Meningitis and lumbar puncture, 104
Meningitis, acute toxic, 270
Meningitis, purulent, in uraemia, 673
Meningitis, chronic syphilitic, preceding tabes
and general paralysis, 233
Meningitis, traumatic serous, in childhood,
355
Meningitis, tuberculous, 289, 316, 482—Cura-
bility of, 482
Meningococcal arthritis, 360
Meningococcal septicaemia, serum treatment
of, 170
Meningococcal urethritis, 552
Meningococcus epidemic in barracks, 311
Menopause and opotherapy, 605
Menorrhagia, treatment of, 221
MENST: Pernicious anaemia in childhood, 205
 —Chloroma in infancy, 264
Menstruation after ovariectomy, the cuti-
reaction during, 688
Mental activity and smoking, 110
Mental forms, prolonged, of epidemic en-
cephalitis, 670
Mental condition in paralysis agitans, 381
Mental syndrome, a peculiar, following epi-
demic encephalitis, 668
Mercuric chloride, intravenous injections of
for puerperal fever, 550
Mercuric chloride poisoning, unusual case
of, 5
MERLE: Meningococcal arthritis, 360
Mesenteric cysts in infancy, 570
Methyl alcohol poisoning, 347
Methylene blue, polychrome, rapid prepara-
tion of, 102
MEUMANN: High forceps operation in con-
 tracted pelvis, 687
MEXER: Pneumococci in throats of normal
 persons, 32—Infectiousness of whooping-
 cough, 696
MEXERDING: Congenital torticollis, 630
MICHL: Surgical complications of typhus,
 301
MICRON: The undescended testis, 584
Microchemical test for ammonia, 36
Microsporum lanosum causing outbreak of
trinea tonsurans, 344
MIDDLETON: Pulmonary silicosis, 560
Midwife, conjunctival chancere in, 126
Migraine, treatment of, 376
MILLAN: Coma after injury of frontal lobes,
 46
Milk injections in puerperal infections, 281;
in gonorrhoeal conjunctivitis, 465
Milk, subcutaneous injections of in treatment
of mammary hypertrophy, 16
- MINET:** Gangrene of erectile tissue, 387—
 Vaccine treatment of asthma, 672
MINGAZZINI: Experiments on temporary ex-
 clusion of one kidney, 275
MIRALLES: The blood pressure and oedema in
 leucoplaea, 236
Mitral valve, congenital malformation of, 292
MOCHIA: Acute necrosis of the pancreas, 115
MOHRICH: Cerebellar atresia, 320
Mole, hydatidiform, unusual case of, 94—In
association with ovarian cysts, 155
Mole, tubal, calcified, 125
MÜLLER: Simple operation for prolapse of
 rectum in childhood, 567
MOLNAR: Meinicke and Sachs-Georgi reac-
 tions, 132
MONFRINI: Prognosis in syphilis, 41
MONGOLISM, observations on, 322, 698
MONGUZZI: Protein therapy in pneumonia,
 259
MOORE, Irwin: Angiomata of the larynx, 332
MOREAU: Incomplete fractures of scapula,
 728—Direct fractures of calcaneum, 729
MORLAUX: Pharyngeal suppuration secondary
 to mastoid abscess, 214
MORQUIO: Acute and tuberculous meningitis,
 289
MORRIS: Hyperthyroidism, 428
Mortality, infantile, and premature birth, 471
MOSSAJO: Oesophageal stricture treated by
 continuous dilatation, 657
MOTZFELDT: Starvation treatment of diabetes,
 641
MOUCRET: Osteochondritis deformans juveni-
 lis, 172—Fibrous osteitis and inherited
 syphilis, 176—Anterior dislocation of the os
 magnum 511
MOUGEOT: Rate of propagation of the arterial
 pulse wave, 720
MOURE: Cutaneous cancer of the bridge of
 the nose, 537
MOURRET: Congenital atresia and occlusion of
 the choanae, 626
MOZON: Myasthenia gravis with osseous
 changes, 173
MOZER: Complement deviation in surgical
 tuberculosis, 282
Mucosa of laryngeal ventricle, eversion of, 545
MÜLLER: Euterostomy for post operative
 ileus, 676
Mumps, treatment of orchitis in, 119
MÜNZER: Vascular sclerosis, 563
Murphy's button causing intermittent intes-
tinal obstruction, 151
MURRAY: Rupture of uterus in absence of
 cervical dilatation, 127—Fractures of the
 lower end of the radius, 489
Muscular exercise, changes in the heart and
circulation due to, 265
Myasthenia gravis with osseous changes, 173
Myositis, respiratory, 267
Myeloid leukaemia treated with benzol, 432
Myocardial tuberculosis, 726
Myoclonic encephalitis. *See* Encephalitis
Myoclonus, pathogenesis of, 564
Myoma uteri: Late results of conservative
operations for, 188—Operations for, 415
Myxoedema, the pituitary in, 593
- N.
- Necrosis, surgical, 602**
Nasal fossae: Glioma of, 19—Cysts of the
anterior part of, 572
Nasal sinusitis, treatment of, 181
NASSO: Pathogeny and treatment of diabetes
 insipidus, 105—Sudden death in parturient,
 232
NATHAN: Treatment of fractures of spongy
 bones, 597
NAVILLE: Central neurofibromatosis, 165
Necrosis of pancreas, acute, 115
NEILL, Junr: Radium in sarcoma and car-
 cinoma of boue, 542
Neo-arsphenamin, rectal injection of massive
doses of, 601
Neoplasms, intrathoracic, 675
Neo-salvarsan causing arsenical paralysis, 73
—In putrid bronchitis, 483
Nephritis, acute, epidemiology of, 425
Nephritis in childhood, prognosis of, 400
Nephritis, chronic, and arterio-sclerosis,
hypertension in, 68
Nephritis, chronic, "eclampsia" fits in after
decapsulation of kidneys, 661
Nephritis and hepatitis secondary to renal
ulcer of stomach, 740
Nephritis and pregnancy toxemias, pathology
of, 741
Nephritis, subacute, renal decapsulation in,
427
Nerve, auditory, tumours of, 526
Nerve, laryngeal, division of the superior in
laryngeal phthisis, 276
Nerve, recurrent laryngeal, causes of para-
lysis of, 341
Nerve stretching in chronic ulcers of the legs,
384
Nerve tumours, acoustic, 439
Nerve, vagus, motor disturbances of the
stomach and resection of, 204
Nerves, peripheral, regeneration of, 739
Nervous irritability, reduction of, 719
NEUBERGER: Intermittent intestinal obstruc-
 tion caused by Murphy's button, 151

NEUDORFER: End-result of pneumatosis cystoides, 214
 Neuritis, peripheral, in tetany, 10; in pregnancy, 539
 Neuro-encephalitis simulating paralysis agitans, 699
 Neurofibromatosis, central, 1c5
 Neurosyphilis, diagnostic of, 530
 Neuro-syphilis, provocative reaction in the cerebro spinal fluid in, 238
 Neutrophilic leucocytes in pulmonary tuberculosis, 255
 Newborn, treatment of intracranial haemorrhage in, 297—Syphilitic contagion of, 321—Concentration of blood, fever, and loss of weight in, 506. *See also* Infants
 NICOLAS: Prurigo cured by anto-haemotherapy, 534—Erysipelas treated by injections of novocain and adrenaline, 621
 NICOLAYSEN: Disinfectant action of urotropine, 458
 NICOTRA: Disturbance of deglutition in aortic disease, 45
 NIELSEN: Prevalence of scarlet fever, 593
 NINNI: *B. tetoni* in the digestive tract of the herbivora, 695
 Nitrobenzol poisoning, acute, 723
 Nitro-benzol poisoning treated by blood transfusion, 109
 Nitrogen reiduum in infectious diseases, 703
 Nitrous oxide-oxygen anaesthesia, death from, 628
 Nose, cutaneous cancer of the bridge of, 537
 Novocain and adrenaline injections in erysipelas, 621
 NURNBERGER: Viability of spermatozoa, 157

O.

Obstetric cases, retrospect of four thousand, 306
 Obstetric paralysis of the arm, 606
 Obstetric tears of the tentorium cerebelli, 576
 Obstetrical fracture of femur, 60
 Obstruction, intestinal. *See* Intestinal
 Ocular symptoms in lethargic encephalitis, 3; in epidemic encephalitis, 514
 Oedema and blood pressure in hemiplegia, 286
 Oedema of the lungs, acute, Caesarean section in, 715
 Oedema, subcutaneous, in sero-fibrinous pharyngitis, 509
 Oedema, war, pathology of, 523
 Oesophageal stricture, 409; treated by continuous dilatation, 657
 Oesophago-tracheal fistulae, 640
 Oesophagus, cancer of. *See* Cancer
 OLSITZKY: Filtrable bodies in influenza, 472
 OLLERENSHAW: Cysts of the semilunar cartilages, 600
 OLLIVIER: False perforation in paratyphoid B fever, 79
 Ophthalmic zoster followed by thrombosis of the central artery of the retina, 182
 Ophotherapy and the menopause, 605
 Optic atrophy, traumatic, 361
 Oral symptoms of disease, 504
 Orchitis in mumps treatment of, 119
 ORR: Treatment of fractures, 354
 Osmagnum, anterior dislocation of, 541
 OSNATO Michael: Trauma and other non-specific influences in paresis, 231
 Osteitis, fibrous, and inherited syphilis, 176
 Osteitis mastoides zygomatica, 284
 Osteochondritis deformans juvenilis, 172
 Osteomalacia, famine, 88—Vertebral, 656
 Osteomyelitis treated with antistaphylococcic vaccine, 47
 Osteomyelitis, the blood in, 691
 Osteomyelitis, chronic pyogenic, 130
 Osteomyelitis of ribs, acute, 271
 Otitis media, acute, and acute articular rheumatism, 565
 Otitis media, acute purulent, in children, 546
 Otitis media, acute suppurative, auto-vaccination for, 571
 Otiogenic meningitis, acute, 270
 Oto-laryngology, suction in, 516
 Oto-rhino-laryngology, vaccine treatment of, 243
 Otraw: Fibromyoma of the urethra, 607
 Onabain and digitalis, 72
 Onabain therapeutic action of, 725
 Ovarian changes, polycystic, 122
 Ovarian cyst: A physical sign of 249—Caesarean section for obstruction by, 685
 Ovarian cysts in association with hydratidiform mole, 155
 Ovarian cysts, pedicular torsion of, 31
 Ovaries sterilized by r rays, 636
 Ovariectomy, cuti reaction during menstruation after, 688
 Oxycephaly and blindness, 4
 Ozaena: Pepsin treatment of, 114—Treatment of, 515

P.

PAGE: The electro-cardiograph, 536
 PADDOCK: Bronchial asthma, 619
 PAL: Primary hypertension, 611
 PALMEN: Rab-bite fever, 319

Pancreas: Acute necrosis of, 11
 Acute infections of, 464
 PARACOSTAS: A new serum reaction in syphilis, 95
 Papillomatosis, gastric, 130
 Paratyphoid vaccination, 379
 PARAF: Varicose veins treated by intravenous injections of sodium bicarbonate, 117
 Paraffin, histological examination of the skin after subcutaneous injections of, 13
 Paralysed feet, removal of astragalus in, 86
 Paralysis agitans: The mental conditions in, 381—Simulated by neuro-encephalitis, 679
 Paralysis, arsenical, due to neo-sarsan, 73
 Paralysis, facial, bilateral peripheral, 141
 Paralysis, general, colloidal gold reaction in, 337
 Paralysis, general, and tabes, preceded by chronic syphilitic meningitis, 253
 Paralysis of the recurrent laryngeal nerve, causes of, 341
 Paralysis, obstetric, of the arm, 605
 Paralysis, spastic Stodols operation for, 488
 Paraplegia, spastic, familial, 18
 Parathyroid tetany in infancy, 42
 Parathyroid transplantation in post-operation tetany, 580
 Paratyphoid B fever, false perforation in, 79
 Paravertebral dullness in carcinoma of oesophagus, 627
 Parenchymatous keratitis and trauma, 711
 Paresis, trauma and other non-specific influences in, 231
 PARK: Acrobachycephaly, 43
 PARMENTER: Tetrachlorethane poisoning, 724
 PARODI: Bronchiectasis after influenza 200—Pleural effusions in artificial pneumothorax, 476
 PARTRIER: Clinical examination of the duodenum, 539
 PATEL: Mammary hypertrophy treated by subcutaneous injection of milk, 16
 Patella, excision of for congenital dislocation, 15
 PAUS: Characteristics of appendicitis in old age, 681
 PAUSINI: Early diagnosis of cholera, 313
 PECK: Treatment of septic abortion, 438
 Pedicular torsion in ovarian cysts, 31
 PEDROLLO: Haemato-genous renal infection, 160
 PECH: Congenital prooxymal cyanosis, 34
 PEHLER: Tuberculosis mortality in Vienna before and after the war, 481
 Pelvic kidney. *See* Kidney
 Pelvic lavage in pyelitis of pregnancy, 689
 Pelvis, contracted, high forceps operation in, 687
 Pelvis, female, varicose veins of, 277
 Pemphigus, turpentine injections in, 505
 Pepsin treatment of ozaena, 114
 Pepsin-hydrochloric acid in digestion of keloids, cicatrices, and tubercles, 315
 PIAZZI: Etiology of repeated abortions, 547
 Perichondritis, acute primary, of the larynx, 81
 Perineal hysterectomy, 684
 Perineal tear, complete, operation for, 59
 Periperal neuritis. *See* Neuritis
 Peripheral, vasomotor and pulmonary reactions, 65
 Peritonitis, gonorrhoeal, 13
 Peritonitis and intestinal obstruction, in pregnancy, labour, and the puerperium, 152
 Peritonitis, puerperal, posterior colpotomy for, 220
 Permanganate of silver in treatment of urinary diseases, 651
 Pertussis, sudden death in, 232
 PERRY: Treatment of hyperaesthesia gravidarum, 247
 Rupture of uterus treated expectantly, 608
 Pessaries, use of, 443
 PESTALOZZI: Statistics of septic abortions, 190
 PETERS: Carcinoma of the tongue, 466
 PETERSEN: Sachs-Georgi reaction, 581
 PETERSON: Pelvic kidney mistaken for haematometra, 192
 PETIT: The prolonged mental forms of epidemic encephalitis, 670
 PETREN: Epidemiology of acute nephritis, 425
 PLAWNY: The blood in osteomyelitis, 691
 PEIFFER: Management of breast presentation, 333
 PENNINGER: Serum diagnosis of tuberculosis of cattle, 419
 Phagocytes, the staining of, 452
 Pharyngeal suppuration secondary to mastoid abscess, 248
 PHILIP: Glioma of the nasal fossae, 1
 Phthisis. *See* Tuberculosis
 Physiology of wound repair, 175
 PICCAGNONI: Primary tumours of the vagina, 421
 PICHLER: The peculiar odour of jaundiced persons, 555
 PICO: Sachs-Georgi reaction in syphilis, 449
 PICOT: Perineal hysterectomy, 684
 Picro-carminic staining of sections, 524
 PILPER: Psoriasis in South Africa, 533
 PILLATT: Subretinal cysticercosis, 82
 PILOTTI: Pathogenesis of myoclonus, 664
 PINARDI: Intestinal obstruction due to gall stones, 118
 PIOTROWSKI: Lethargic encephalitis of long duration, 669

PIPING: Lethargic encephalitis in children, 200
 PIRONDINI: Masked cystalgic pyelitis, 682
 Pituitary extract and histamin in diabetes insipidus, 671
 Pituitary gland, experimental exposure of to r rays, 422
 Pituitary in Graves's disease and myxoedema, 593
 Placenta: Detachment of by Gabaston's method, 154—Removal of by Gabaston's method, 633
 Placenta, indirect expulsion of, 518
 Placenta, normally situated, premature separation of, 25-217
 Placenta praevia: Unusual mechanism of labour in, 123—Treatment of, 362—With severe haemorrhage treated by vaginal Caesarean section, 392
 Placenta, retention of, 632
 Placentae, syphilitic, 469
 Plague, Indian: Diagnosis of, 163—Blood cultures in, 399
 Plantar reflex in early life, 557
 PLAXY: Relationship between lethargic encephalitis and epidemic haemorrhagic septicaemia, 622—Septicaemia, interhaemorrhagic, 665
 PLATT: Use of propyl alcohol in surgery, 358
 Pleura, primary tumour of, 395
 Pleural adhesions, demonstration of, 402
 Pleural effusions in artificial pneumothorax, 476-477
 Pleurisy with effusion on the "sound" side in artificial pneumothorax, 644
 PLURISV, sero-fibrinous, subcutaneous oedema in, 509
 POUCHET: Hirsutism and diabetes mellitus, 529
 Pneumatosis cystoides, end-result of, 214
 Pneumococcal septicaemia, 727
 Pneumococci in throats of normal persons, 32
 Pneumococci and streptococci in influenza, 617
 Pneumococcus, different types of, 251
 Pneumonia, influenza, treated with serum from convalescents, 8
 Pneumonia, protein therapy in, 259
 Pneumoperitoneum and radiological diagnosis, 708
 Pneumothorax, artificial, consecutive bilateral, 139
 Pneumothorax, artificial, duration of, 645
 Pneumothorax, artificial, in fractured ribs, 329
 Pneumothorax, artificial, pleural effusions in, 476, 477, 641
 Pneumothorax, artificial, pleurisy with effusion on the "sound" side in, 644
 Pneumothorax, artificial, in bilateral tuberculosis, 646
 Pneumothorax, artificial, in treatment of pulmonary tuberculosis, 209, 478
 Poisoning, fatal borax, 293
 Poisoning by mercuric chloride, unusual case of, 5
 Poisoning methyl alcohol, 347
 Poisoning, acute nitro-benzol, 723
 Poisoning by nitrobenzol treated by blood transfusion, 109
 Poisoning, senecio, 44
 Poisoning, tetrachlorethane, 724
 Poisoning, trinitro-toluol, 235
 Poisoning, zinc chloride, 722
 POLKARD: Fate of transplanted bone, 408
 Poliomyelitis, acute, serum treatment of, 317
 Poliomyelitis, acute anterior, simulating apendicitis, 510
 Poliomyelitis in the adult, transient acute, 37
 Polychrome methylene blue, rapid preparation of, 102
 Polycystic ovarian changes, 122
 Polyneuritis following influenza, 589
 Polyneuritis, syphilitic, 145
 Polyp, small mucous, of the corpus uteri as a cause of haemorrhage, 574
 PONTARI: Intradermo and subcutaneous reactions in hydatid disease, 473
 POROVIC: Adeno-fibromata of the breast, 302
 POPPICI: Acute articular rheumatism and acute otitis media, 555
 PORCELLI: Calomel injections in an aqueous solution, 206
 PORRE: The undescended testis, 584
 PORTER: Dystocia due to carcinoma of the foetal kidney, 95
 PORTMANN: Mastoiditis and Pott's disease, 389
 PORROCI: Labour obstructed by fixation of retroverted uterus, 491
 PORTER: Fatal borax poisoning, 293—Delivery by version in normal labour, 694
 POTT's disease and mastoiditis, 389
 POWERS: Acrobachycephaly, 43
 Pregnancy, auricular flutter and fibrillation in, 658
 Pregnancy, blood ferments in, 254
 Pregnancy and cardiac insufficiency, 633
 Pregnancy, chlorostrophia in, 520
 Pregnancy, ectopic, and rupture into the caecum, 185
 Pregnancy, sedimentation velocity of erythrocytes during, 609
 Pregnancy complicated by fibroids, 494
 Pregnancy, glycosuria in, 153
 Pregnancy, labour, and the puerperium, in intestinal obstruction and peritonitis in, 152
 Pregnancy, peripheral neuritis in, 549
 Pregnancy, persistent vomiting of, 517
 Pregnancy, physiological anaemia of, 218

- Pregnancy and puerperium, heart disease in, 634
 Pregnancy, pyelitis of, pelvic lavage in treatment of, 689
 Pregnancy, retinitis during, 578
 Pregnancy, a sign of, 414
 Pregnancy and the thyroids, 62
 Pregnancy toxæmia and nephritis, pathology of, 741
 Pregnancy, tubal, and intestinal obstruction, 184
 Pregnancy. *See also* Gestation
 Pregnant wife of a syphilitic (question of treatment), 363
 PRINZING: Treatment of febrile cases of abortion, 467
 Prepil alcohol use of in surgery, 358
 Prostatectomy, breast enlargement after, 304
 Protein therapy in pneumonia, 259
 Preteinnuria, Bruce-Jones, 525
 PROUBASTA: Acquired vaginal stricture, 309
 Prurigo cured by auto-hæmotherapy, 534
 Pseudo-leukaemic splenic anaemia in infants, 643
 Psoriasis: Recurrence after use of chryso-robin, 111—Influence of trauma on the distribution of, 167—A spirochaete associated with, 256—In South Africa, 534
 Protein sensitization in eczema, 164
 Puerperal fever, intravenous injections of mercuric chloride in, 550
 Puerperal infections: Abdominal hysterectomy for, 92—Milk injections in, 281
 Puerperal peritonitis. *See* Peritonitis
 Puerperal thrombosis of vagina, 279
 Puerperium, heart disease in, 634. *See also* Pregnancy
 Pulmonary influenza. *See* Influenza
 Pulmonary, peripheral and vasomotor reactions, 65
 Pulmonary silicosis, 560
 Pulmonary tuberculosis. *See* Tuberculosis
 Pulse wave, arterial, rate of propagation of, 720
 PUPILLI: The etiological significance of *B. proteus vulgaris* in cholera infantum, 438
 PURDY: Maternal mortality in childbirth, 391
 Purpura in cerebro-spinal meningitis, 106
 Pyæmia, streptococcal serum in, 202
 Pyelitis, masked cystalgic, 682
 Pyelitis of pregnancy, pelvic lavage in treatment of, 689
 Pyelography and uroterography, 732
 Pyelonephritis, 553
 Pyelonephritis following pregnancy cured by intravenous injections of urotropine, 156
 Pyloric sphincter in man, control of, 17
 Pylorus, hypertrophic stenosis of, 625
- Q.
- QUACKENBOS: Hydrocele in children, 540
 Quinidine in heart disease, 620
- R.
- Rabies, histological lesions in a case of, 423
 Radiation treatment of cancer of uterus, 308
 Radiological diagnosis and pneumoperitoneum, 708
 Radiotherapy of the endocrine glands, 429
 Radium in sarcoma and carcinoma of bone, 542
 Radium treatment of acromegaly, 208
 Radium treatment of cancer of cervix, extended hysterectomy after, 128
 Radium treatment of cancer of uterus, 334
 Radium treatment of hæmorrhage at the climacteric, 416
 Radium, fractures of the lower end of, 489
 RAILLIET: Epidemic hiccough at Rheims, 135
 RAMIREZ: Protein sensitization in eczema, 164
 RAMOND: Adenitis in herpes zoster, 6
 RAMSAY: Hypertrophic stenosis of pylorus, 625
 RANUCCI: Action of spinal anaesthesia on the hepatic and renal functions, 710
 RASCH: Heliotherapy in secondary syphilis, 75
 RASCK: Spirochaete associated with psoriasis, 255
 Rat-bite fever, 319
 RATHERY: Hypertension in chronic nephritis and arterio-sclerosis, 68—Can a diabetic be allowed to lose flesh? 642
 RATIE: Blindness and oxycephaly, 4
 Reactions, peripheral, vasomotor and pulmonary, 65
 Recklinghausen's disease, 229
 Rectum, prolapse of in childhood, simple operation for, 567
 Rectal anaesthesia, 241
 Rectal injection of massive doses of neoarsphenamin, 601
 REDER: Pathology and treatment of leucorrhœa, 713
 Reed dermatitis, 434
 REH: Iosomnia in children, 594
 REICHENFELD: Coloured colostrum, 364
- REILLY: Blood cultures in bubonic plague, 399
 REIMER: X-ray treatment of acne vulgaris, 617
 REMY: Hydrocephalic form of cerebro spinal meningitis in infants, 502
 Renal calculi in soldiers, 385
 Renal calculus and Meinicke reactions, 132
 Renal decapsulation in subacute nephritis, 427
 Renal functions, action of spinal anaesthesia in, 710
 Renal glycosuria, 339
 Renal infection, hæmatogenous, 160
 Renal pedicle, hydatid cyst of, 57
 Renal test meal, 518
 Renal tuberculosis, 485—Spontaneous recovery from, 380—Extension of, 412—Thermo-precipitin reaction in diagnosis of, 583
 RENON: Herpes of the anal region with meningeal symptoms, 459
 Respiratory affections in children, x-ray examination of the chest in, 228
 Respiratory mycoses, 267
 Reticulated red corpuscles. *See* Blood
 Retina detached, operation for, 150
 Retina, thrombosis of the central artery of, following ophthalmic zoster, 182
 Retinitis during pregnancy, 578
 Retropharyngeal abscess. *See* Abscess
 REYN: Limitations of x-ray treatment in tuberculous adenitis, 629
 REYNOLDS: The control of the pyloric sphincter in man, 17
 Rheims, epidemic hiccough at, 135
 Rheumatism, acute articular, and acute otitis media, 565
 Ribs, acute osteomyelitis of, 271
 Ribs, fractured, artificial pneumothorax in, 329
 RICHT: Prevention of anaphylactic shock, 522—Hepatitis and nephritis secondary to round ulcer of stomach, 740
 RICHTER: Lumbar anaesthesia, 461
 RICHTER QUILNER: The metabolism in vascular hypertension, 527
 RIVERS: Iodol in cerebro-spinal fluid in influenza meningitis, 252
 RIVIÈRE: Caesarean section for obstruction by ovarian cyst, 685
 ROSENDA: Iosomnia as a sequel of lethargic encephalitis, 433
 ROBERTSON: Senecio poisoning, 44—Non-union following fractures, 731
 ROCCAVILLA: Foreign body in the heart, 440
 ROCHET: Congenital occlusion of the small intestine, 53
 RODANO: Artificial pneumothorax in pulmonary tuberculosis, 478
 ROEDERER: Arthropathies in sclerodermia, 266
 ROELOFS: Herpes ophthalmicus, 149
 ROMBACH: Alkaptonuria, 579
 ROSENBLATT: Pleural effusions in artificial pneumothorax, 477
 ROTICA: Trauma and parenchymatous keratitis, 711
 RÖSLER: Action of intravenous injections of calcium lactate on the blood picture, 582
 ROSSEL: Pleurisy with effusion on the "sound" side in artificial pneumothorax, 644
 ROSSI: Action of bile on the spinal centres, 33
 ROSSON: Primary tumour of pleura, 395
 Round ligaments. *See* Ligaments
 RUBINO: Tritol (trinitrotolol) poisoning, 235
 RUGE: Incubation chamber treatment of premature or very small infants, 58
 RUSKA: X-ray examination of the chest in acute respiratory affections in children, 228
- S.
- SARRAZÉS: Acute leukaemia, 528
 Saccharin intoxication, 704
 Sachs-Georgi reaction in syphilis, 449, 581
 Sachs-Georgi and Meinicke reactions, 132
 SALA: Reflex calculus auria, 178
 Salvarsan, histological changes produced by, 161
 Salvarsan injection in non-syphilitic cases followed by jaundice, 499
 SALVETTI: Manton's intradermo reaction in infantile tuberculosis, 168
 Sapheno-femoral anastomosis, 411
 Sarcoma of bone, radium in, 542
 Sarcoma, bilateral testicular, 450
 Sarcoma of stomach, 610
 Sarcoma, unusual case of, 257
 Sarcoma of uterus, 63
 SARGNON: Gunshot wounds of the mastoid, 438
 SAUGMAN: The demonstration of pleural adhesions, 402—Treatment of tuberculous empyema, 436
 Scabies, eosinophilia in, 283
 SCALINCI: Medical treatment of incipient cataract, 48
 Scapula, incomplete fractures of, 728
 SCHAANNING: Five-year-old foetus loose in the abdominal cavity, 189—Spontaneous recovery from renal tuberculosis, 580
 SCHERINGA: Iodine powder as a substitute for tincture of iodine, 683
 SCHIFF: Famine osteomalacia, 88
 SCHMID: Late results of conservative operations for myoma uteri, 188
 SCHMIDT: Causes of paralysis of the recurrent laryngeal nerve, 341
 SCHLASSI: Auto-hæmaphysalis in paroxysmal hæmoglobinuria, 500
 SCHNELL: Neo-salvarsan in putrid bronchitis, 483
 SCHONBAUER: Treatment of tetanus by curare, 674
 SCHÖNLEB: Indications for operation in gastric ulcer, 650
 SCHOU: The cerebro spinal fluid in early syphilis, 223
 SCHRODER: Treatment of cerebro-spinal syphilis, 296
 SCHROEDER: Neo-salvarsan in putrid bronchitis, 483
 Schultz-Charlton test for scarlet fever, 591
 SCHWARTZ: Control of the pyloric sphincter in man, 17—Posterior colotomy for puerperal peritonitis, 2.0—Indications for symphysiotomy, 737
 SCHWEITZER: Late results of hysterectomy for cancer of cervix, 390
 Sciatica, predisposing causes of, 374
 Sclerodermia, arthropathies in, 266
 Sclerosis, vascular, 563
 Sclerotic, tuberculous of, 11
 Scorbutic dyscory, 382
 Scrofula institutions, importance of Wassermann's reaction in, 83
 Scurvy, infantile, 501
 SEACON: Diverticula of urinary bladder, 680
 Sections, picrocarmine staining of, 524
 SEGALL: Bacteriology of dysentery, 396
 SEGRE: Deayed union in fractures, 544
 SELLEKS: Blood changes in lead workers, 475
 Semilunar cartilages, cysts of, 600
 Semi-symphysiotomy, 690
 Senecio poisoning, 44
 Septic infections of the urinary passages in children, 171
 Septicæmia, colloidal gold in, 148
 Septicæmia, meningococcal, serum treatment of, 170
 Septicæmia, pneumococcal, 727
 SERRA: The intradermo reaction in the diagnosis of hydatid disease, 496
 Serum, anti-pneumococcus, 290
 Serum diagnosis of tuberculosis of cattle, 419
 Serum, horse in treatment of melæra neonatorum, 265
 Serum, human, malaris following injections of, 112
 Serum, preparation of on a large scale, 372
 Serum treatment of meningococcal septicæmia, 170
 Serum treatment of acute poliomyelitis, 317
 SEVER: Removal of astragalus in paralytic feet, 86
 Sex glands, transplantation of, 326
 SHIGA: Early treatment of tuberculosis, 291
 Shock, anaphylactic, prevention of, 522
 Shock and exhaustion, mechanism of, 198
 SHOHL: Cultivation of the gonococcus, 418
 SICARD: Varicose veins treated by intravenous injections of sodium bicarbonate, 117
 SIEBER-HUEGENS: Congenital syphilis in the second generation, 457
 Silicosis, pulmonary, 560
 Silver permanganate in treatment of urinary diseases, 631
 SIMPSON: Renal decapsulation in subacute nephritis, 427
 SINDONI: Bacteriology of influenza in 1918-20, 67
 Singer's thirst cure for bronchiectasis, 647
 Skin diseases, application of cutaneous sensitization to, 694
 Skin eruptions in influenza, 9
 Skin, histological examination of after subcutaneous injections of paraffin, 613
 Skin roughness in tuberculous subjects, 237
 SMALL: Influence of trauma in the distribution of psoriasis, 167
 Small-pox and tuberculosis, 137
 Smoking and mental activity, 110
 Sodium bicarbonate, intravenous injections of in treatment of varicose veins, 117
 Sodium citrate treatment of thrombo-angitis obliterans, 349
 Sodium morrhuate in pulmonary tuberculosis, 238
 SOLAR, Levy: Heart disease in pregnancy and puerperium, 634
 SOLI: Bactericidal power of the intestinal mucosa, 551
 SOLOMON: Provocative reactions in the cerebro-spinal fluid in neuro-syphilis, 288
 SORDELLI: Preparation of serum on a large scale, 372
 SÖRENSEN: Syphilis simulating pulmonary tuberculosis, 39
 SORESI: Artificial pneumothorax in fractured ribs, 329
 SOUCRET: Association of tonsillar chancre with Vincent's angina, 678
 Spermatozoa viability of, 157
 Sphincter pyloric, control of in man, 17
 Spina bifida occulta and chronic trophœdema, 20
 Spinal anaesthesia, action of on the hepatic and renal functions, 710
 Spinal centres, action of bile on, 33
 Spirochaeta pallida: Demonstration of in tissues, 312—Dissemination of in experimental syphilis, 338

- Spirochaete associated with psoriasis, 256
Spirochaetae in lymphatic glands, 103—In the urine in secondary syphilis, 397
Spirochaetosis, bronchopulmonary (Castellani), 375
Spirochaetosis icterohaemorrhagica, 665
Splenectomy in treatment of pernicious anaemia, 403
Spleen, rupture of in malaria, 263
Splenic vein, thrombosis of, 295
Splenomegaly due to arsenocholesterol, 269
STANGL: Atypical epidemic encephalitis, 667
STARR: Tea intoxication, 561
STARRY: Demonstration of *Spirochaeta pallida* in tissue, 312
STEEL: Sodium citrate treatment of thrombo-aneuritis obliterans, 349
STEIN: Syphiloma vulvae, 30—Pneumoperitoneum and radiological diagnosis, 708
STENBACH: Intrathoracic neoplasia, 675
STERN: Hypertrophic, of pylorus, 625
Sterilization, operation for, 575
STEWART: Pneumoperitoneum and radiological diagnosis, 708
STIENON: Myeloid leukaemia treated with benzol, 432
STIRLING, A. W.: Influence of age upon astigmatism, 245
STRIVELMAN: Pleural effusions in artificial pneumothorax, 477
STROCK: Experimental production of gastric ulcer, 637
Stoffel's operation for spastic paralysis, 488
Stoker's cramp, 318
Stomach, motor disturbances of, and resection of the vagus, 204
Stomach, normal regurgitation of duodenal fluid into, 203
Stomach, post-operative atony of, strychnine in, 84
Stomach, sarcoma of, 610
STRAULI: Caesarean section in acute oedema of the lung, 715
Streptococcal serum in pyaemia, 202
Streptococci and pneumococci in influenza, 697
STROUSE: Renal glycosuria, 339
Strychnine in post-operative atony of the stomach, 84
Subretinal cysticercosis, 82
Sudan, *Toxoplasma pyrogenes* Castellani in, 70
Sugar injections, effect of on anaesthesia, 327
Suprarenal capsules removed for epilepsy, 435
Surgery, Dakin's solution in, 325
Surgery, war, statistics of, 22
Surgical narcosis, 602
SURREAU: Acute otogenic meningitis, 270
SWARTZ: Cultivation of the gonococcus, 418
SWEET: Acute infections of the pancreas, 464
Switzerland, lethargic encephalitis in, 236
SVYNGEDATW: Excision of the patella for congenital dislocation, 15
Symphysiotomy, indications for, 737
Syphilis, cerebro-spinal treatment of, 296—Diagnosis and prognosis of persistent, 406
Syphilis, congenital, in the second generation, 457
Syphilis, early, the cerebro-spinal fluid in, 223
Syphilis, experimental, dissemination of *Spirochaeta pallida* in, 338—Abortive treatment of, 662
Syphilis of the external ear, 116
Syphilis, gastric, 653
Syphilis, hereditary, etiological relationship between congenital anomalies and, 407
Syphilis, inherited, and fibrous osteitis, 176
Syphilis, new serum reaction in, 98
Syphilis, prognosis in, 41
Syphilis, pulmonary, 426
Syphilis, Sachs-Georgi reaction in, 449, 581
Syphilis, secondary, heliotherapy in, 75
Syphilis, secondary, spirochaetes in the urine in, 397
Syphilis simulating pulmonary tuberculosis, 39
Syphilitic aortitis, case of, 40
Syphilitic contagion of the newborn, 321
Syphilitic disease of the cervical vertebrae, 212
Syphilitic mastitis, 654
Syphilitic polyneuritis, 145
Syphiloma vulvae, 30
Syphilitic placenta, 469
SZLAPKA: Treatment of pernicious anaemia by splenectomy, 403
- T.
- Tabes, familial, 162
Tabes and general paralysis preceded by chronic syphilitic meningitis, 233
TANON: Blood cultures in bubonic plague, 399
TAPIA: Eversion of the mucosa of the laryngeal ventricle, 545
Tartar emetic, intravenous injection of, 345
Tea intoxication, 561
Tears, obstetric, of the tentorium cerebelli, 576
Teeth, infective processes in, and internal diseases, 503
TEISSIER: Blood cultures in bubonic plague, 399
Telangiectasis, 351
Tendon repair, dead grafts for, 55
- TEN THIE: Amyloid disease of the lung, 556
Tentorium cerebelli, obstetric tears of, 576
Testes, transplantation in man, 356
Testis, the undescended, 584
Testicular sarcoma, bilateral, 450
Tetanus treated by curare, 674
Tetany, parathyroid, in infancy, 42
Tetany, peripheral neuritis in, 10
Tetany, post operation, parathyroid transplantation in, 580
Tetrachlorethae poisoning, 724
THALER: Successful extirpation of primary tubal cancer, 470
THALHEIMER: Haemoglobinuria after a second blood transfusion with same donor, 716
THELIN: Treatment of placenta praevia, 362
Thermo-precipitin reaction in diagnosis of renal tuberculosis, 583
THIBAUT: Rapid preparation of polychrome methylene blue, 102
THIERY: Vaginal cyst, probably of Wolfian origin, 29
Thirst cure for bronchiectasis. See Bronchiectasis
THOMAS: Auricular flutter and fibrillation in pregnancy, 658
THOMSEN: Are there several strains of gonococcus? 227—The different types of pneumococcus, 251—A meningococcus epidemic in barracks, 311
Thoracoplasty in the treatment of pulmonary tuberculosis, 174
Thrombosis of the central artery of the retina following ophthalmic zoster, 182
Thrombosis, puerperal, of the vagina, 279
Thrombosis of the splenic vein, 295
Thrombo-angiitis obliterans treated by sodium citrate, 349
Thumb, luxations of, 144
THURSFIELD: Mongolism, 698
Thyroid extract in Köhler's disease, 531
Thyroids and pregnancy, 62
TIBALDI: Parasitic amoeba in the tonsils, 100
TILLIER: Development of bone, 448
TIMPANO: Read dermatitis, 434
Tiua tonsians outbreak due to *Microsporion lanosum*, 344
TOLDERLUND: Singer's thirst cure for bronchiectasis, 647
Tonsil, abscess of. See Abscess
Tonsillar chancre associated with Vincent's angina, 678
Tonsils, parasitic amoeba in, 100
Torticollis, 54
Torticollis, congenital, 630
Tourniquet for intravenous injections, 733
Toxaemias of pregnancy, pathology of, 741
Toxoplasma pyrogenes Castellani in the Sudan, 70
Trauma and other non-specific influences in paresis, 231
Trauma: Influence of on the distribution of psoriasis, 167—And diabetes, 484—And parenchymatous keratitis, 711
TRIER: Causes of abortion and premature labour, 635
Trilot (trinitrotoluol) poisoning, 235
TRON: Schultz-Charlton test for scarlet fever, 591
Trophoedema, chronic, and spina bifida occulta, 20
Tubal gestation. See Gestation
Tubercle bacilli, new method of facilitating detection of, 368
Tuberculin treatment, 138
Tuberculosis, bilateral, artificial pneumothorax in, 646
Tuberculosis of the bladder, primary, 12
Tuberculosis of bones and joints, surgical treatment of, 598
Tuberculosis of cattle, serum diagnosis of, 419
Tuberculosis of the cervix, 93
Tuberculosis in Denmark, decline of, 234
Tuberculosis of the ear, 413
Tuberculosis of the female genitals, 66
Tuberculosis of the male genital tract, 462
Tuberculosis and heredity, 258
Tuberculosis, infantile. Mantoux's intradermo reaction in, 168
Tuberculosis, intestinal, 388; and the anaemia of consumptives, 455
Tuberculosis of knee, epithelioma following x-ray treatment for, 693
Tuberculosis of larynx cured by galvanocauterization, 213
Tuberculosis of larynx, division of superior laryngeal nerve in, 276
Tuberculosis mortality in Vienna before and after the war, 481
Tuberculosis, myocardial, 726
Tuberculosis, pulmonary, artificial pneumothorax in treatment of, 209, 478
Tuberculosis, pulmonary, blood ferments in, 254
Tuberculosis, pulmonary, early diagnosis of, 7
Tuberculosis, pulmonary, neutrophile leucocytes in, 255
Tuberculosis, pulmonary, modern methods of treatment in, 38
Tuberculosis, pulmonary, sodium morrhuate in, 238
Tuberculosis, pulmonary, simulated by syphilis, 39
Tuberculosis, pulmonary, thoracoplasty in the treatment of, 174
Tuberculosis, rapid sero-diagnostic method in, 159
- Tuberculosis, rate of sedimentation of the blood cells in, 369
Tuberculosis, renal, 485—Spontaneous recovery from, 380—Extension of, 412—Thermo-precipitin reaction in diagnosis of, 583
Tuberculosis of the sclerotic, 11
Tuberculosis and small-pox, 137
Tuberculosis, surgical: Complement deviation in, 282—Treated with parial antiseptics, 538
Tuberculosis, early treatment of, 291
Tuberculosis vaccine, Friedmann's effects of, 479, 480
Tuberculosis and war injuries, 532
Tuberculosis, Wildbolz's auto-urine reaction in, 195
Tuberculous adenitis. See Adenitis
Tuberculous empyema. See Empyema
Tuberculous meningitis. See Meningitis
Tuberculous subjects, roughness of the skin in, 237
Tuberculous ulceration of the labial commissures, symmetrical, 595
Tumour of plerua, primary, 395
Tumours, acoustic nerve, 439
Tumours of the auditory nerve, 526
Tumours of intestine, benign, 143
Tumours, renal, adenoma sebaceum and, 398
Tumours of vagina, primary, 421
Turpentine injections: For gynaecological infections, 447—In pemphigus, 505
TURRETINI: Lethargic encephalitis of long duration, 669
TURRO: Extraction of leucocytic ferments, 340
TURTLE: Ulcer of cornea, 490
Typhoid fever. See Fever, enteric
Typhoid spine treated by vaccines, 543
Typhus fever. See Fever
- U.
- Ulcer of cornea, 490
Ulcer, duodenal: End-results of the operative treatment of, 210—Statistics of, 652—Barium sulphate treatment of, 702
Ulcer, gastric: Diagnosis of, 386—Experimental production of, 637—Indications for operation in, 650—Statistics of, 652—Barium sulphate treatment in, 702
Ulcer, jejunal, post-operative, etiology and prophylaxis, 240
Ulcer, jejunal, following gastro-enterostomy, 353
Ulcer, round, of stomach, hepatitis and nephritis secondary to, 740
Ulcers, simple perforating, of caecum and colon, 52
Ulcers of legs, chronic, nerve stretching, 384
Ulcers, varicose, ambulatory treatment of, 199
Uraemia, purulent meningitis in, 673
Ureter implanted into bowel, 651
Ureteral calculus, morning pain in, 734
Ureterography and urography, 732
Urethra, fibromyoma of, 607
Urethral stricture, unusual case of, 124
Urethritis, meningococcal, 552
Urinary antisepsis, 513
Urinary diseases, permanganate of silver in treatment of, 631
Urinary passages in children, septic infections of, 171
Urine in secondary syphilis, spirochaetes in, 397
Urotropine: Pyelonephritis following pregnancy cured by intravenous injections of, 156—Disinfectant action of, 558
USLAND: Detachment fractures following strain, 113
Uterine cancer. See Cancer
Uterine fibroid. See Fibroid
Uterine fibroma. See Fibroma
Uterine infection, intrauterine therapy for, 91
Uterine inversion, acute, 660
Uterine inversion, chronic, histological changes in, 638
Uterus, small mucous polyp of the body of as a cause of haemorrhage, 574
Uterus, myoma of, late results of conservative operations for, 188
Uterus, insertion of the round ligaments and diagnosis of impending rupture of, 23
Uterus, retroverted, fixation of, obstructing labour, 491
Uterus, rupture of treated expectantly, 608
Uterus ruptured at Caesarean scar, 186
Uterus, threatened rupture of in premature birth by transverse presentation, 127
Uterus, sarcoma of, 63
Uterus, ventrofixation of, followed by intestinal obstruction, 216
UTHIRI: Concentration of blood, fever, and loss of weight in the newborn, 506
- V.
- Vaccination in country districts, 458
Vaccination, paratyphoid, 559
Vaccine treatment: Of empyema, 76—Of typhoid fever, 166, 261—In oculo-rhino-laryngology, 243—Of gonorrhoea, 511—Of typhoid spine, 543—Of asthma, 672

Vaccine, tuberculosis. *See* Tuberculosis
 Vagina, primary tumours of, 421
 Vagina, puerperal thrombosis of, 279
 Vagina, ventrofixation of, 577
 Vagina and cutaneous diphtheria, 28
 Vaginal cyst probably of Wolfian origin, 29
 Vaginal preparation for extended hysterectomy, 27
 Vaginal stricture, acquired, 309
 VAGLIO: Cerebral diplegia and Little's disease, 80—Treatment of intracranial hæmorrhage in the newborn, 297
 Vagus nerve. *See* Nerve
 VALENTE: Mesenteric cysts in infancy, 570
 VALLARDI: Modern methods of treatment in pulmonary tuberculosis, 38
 VAN DEN BRANDEN: Vaccine therapy of gonorrhœa, 511
 VAN DER PERK: Cancer of stomach with remarkable metastases, 666
 VAN DER TAK: Premature separation of the normally implanted placenta, 217
 VAN DIJK: Malaria caused by injections of human serum, 112
 VAN GELDEREN: Histological examination of the skin after subcutaneous injections of paraffin, 613
 VAN LIER: Benign intestinal tumours, 143
 VAN TILBURG: Effects of Friedmann's tuberculosis vaccine, 480
 VANVERTS: Management of labour after previous Caesarean section, 417
 VAQUEZ: Digitalis and ouabain, 72
 Varicocele, end-results of operation for, 463
 Varicose ulcers, ambulatory treatment of, 199
 Varicose veins: Treated by intravenous injections of sodium bicarbonate, 117—Of female pelvis, 277—Extraction operation for, 599
 Vascular hypertonus, metabolism in, 527
 Vascular sclerosis, 563
 VASSALLO: Histological changes in chronic uterine inversion, 638
 VASSELLE: Clinical examination of the duodenum, 539
 VAUDESAL: Persistent vomiting during pregnancy, 517
 VAUTRIN: Fibroids complicating pregnancy, 494
 VECCHIA: Abortive treatment of experimental syphilis, 662
 VENOT: Rupture of uterine treated expectantly, 608
 Ventrofixation of uterus. *See* Uterus
 Ventrofixation of vagina. *See* Vagina
 VERDELET: Tuberculosis of the cervix, 93
 VERMELIN: Fibroids complicating pregnancy, 494—Placental retention, 632
 Vertebrae, compression fractures of, 299
 Vertebral osteomalacia, 656
 Vesico-uterine fistula, 61
 Vesico-vaginal fistula, transvesical operations for, 521
 Vienna, tuberculosis mortality in, before and after the war, 481
 VIGNES: Intrauterine therapy for uterine infection, 91
 VILLARD: Hernia of linea alba, 487

VINCENT: Tabes and general paralysis preceded by chronic syphilitic meningitis, 233
 Vincent's angina. *See* Angina
 Vincent's T.A.B. vaccine in typhoid spine, 545
 VINEBERG: Treatment of uterine fibroids, 335
 VIOLET: Unusual case of hydatidiform mole, 94
 VIOLE: Diagnosis of bubonic plague, 163
 VOGELIUS: Singer's thrust cure for bronchiectasis, 647
 VOLLMANN: Nerve stretching in chronic ulcers of the legs, 384
 Volkmann's contracture, 146
 VOLLMOND: Are there several strains of gonococcus? 227
 Vomiting of pregnancy. *See* Pregnancy

W.

WAGERS: Section in oto-laryngology, 516
 WAGNER: The residual nitrogen in infectious diseases, 703
 WALLIS, Mackenzie: Pathology of pregnancy toxæmias and nephritis, 741
 WALTERS: Bence-Jones proteinuria, 525
 WANDER: Epithelioma arising in lupus erythematosus, 424—Application of cutaneous sensitization to diseases of the skin, 694
 War injuries and tuberculosis, 532
 War oedema. *See* Oedema
 War surgery, statistics of, 22
 WARD: Chrysoarobin and psoriasis, 111
 WARTHIN: Demonstration of *Spirochaeta pallida* in tissues, 312
 Wassermann's reaction, importance of in institutions for scrofula, 83
 WEBSTER, Reginald: Lumbar puncture and meningitis, 104
 WEDERHAKKE: Continuous ether narcotization during childbirth, 573
 Weight, loss of in the newborn. *See* Infants, newborn
 WEIL: Hirsutism and diabetes mellitus, 529
 WEISS: Tincture and infusion of digitalis in therapeutics, 454—Cancer of cervix of borderland operability, 686
 Weiss's reaction in typhoid fever, 69
 WELTMANN: Pathology of war oedema, 523
 WERNER: Threatened rupture of uterus in premature birth by transverse presentation, 127
 WERNSTEDT: Pathology of congenital laryngeal stridor, 101
 WERTHEIMER: Congenital occlusion of the small intestine, 53
 WESTERGREN: Rate of sedimentation of the blood cells in tuberculosis, 369
 Whooping-cough, treatment of, 74, 314—Infectiousness of, 696

WIDERÖE: Local anaesthesia for abdominal operations, 121—The etiology of Calvé-Perthes's disease, 554
 WIEGELS: Premature births and infant mortality, 471
 WIGET: Thermo-precipitin reaction in diagnosis of renal tuberculosis, 583
 WIGGELANDAM: Weiss's reaction in typhoid fever, 69
 Wildbolz's auto-urine reaction in tuberculosis, 195
 WILDENKOV: Gonorrhœal peritonitis, 13—Dyspeptic symptoms due to chronic appendicitis, 566
 WILLMOT: Senecio poisoning, 44
 WIMMER: Syphilitic disease of the cervical vertebrae, 212
 WITH: Distribution of lupus vulgaris, 268
 WITHERBEE: X-ray treatment of acne vulgaris, 617
 WOLF: Influences on the metabolism of bacteria, 370
 WORSTER-DROUGHT: Hydrocephalus complicating cerebro-spinal fever, 615
 WOUND repair, physiology of, 175
 WULFF: A meningococcus epidemic in harracks, 311

X.

Xanthochromia, 194
 Xanthoma multiplex, 451—Cholesterol in, 371
 X-ray examination of the chest in acute respiratory affections in children, 228
 X-ray therapy in hyperthyroidism, 592
 X-ray treatment of acne vulgaris, 617
 X-ray treatment of interstitial keratitis, 679
 X-ray treatment in tuberculous adenitis, limitations of, 629
 X-ray treatment for tuberculosis of knee, followed by epithelioma, 693
 X rays, experimental exposure of the pituitary to, 422
 X rays in sterilization of ovaries, 636

Z.

ZAGARI: Chronic cyanosis, 71
 ZANGEMEISTER: Obstetric tears of the tentorium cerebelli, 576
 ZEHRER: Hæmoptysis and the action of camphor, 352
 Zinc chloride poisoning, 722
 ZUCCOLA: Encephalitis lethargica, 586—Therapeutic action of ouabain, 725

EPITOME OF CURRENT MEDICAL LITERATURE.

MEDICINE.

1. The Dietetics of Diabetes.

FILIPPINI (*Il Morgagni*, September 25th, 1920, and *Il Polietnico*, July 3rd, 1920) describes the fasting treatment of Allen. The disappearance of sugar from the urine under this treatment has no relation to the amount originally present, but depends more on the duration of the disease and on the patient's age. When the sugar has disappeared the tolerance for carbohydrates has to be determined by starting with green vegetables containing 5 per cent. of carbohydrates and going on to richer vegetables. The amount of such vegetables seldom reaches 3 grams per kilogram of weight. When the urine has remained free from sugar for two days, the tolerance for albuminoids must be determined; the amount of fish, egg albumen, etc., is increased until 1 gram per kilogram of weight is reached. Subsequently fat may be given. Apart from the fasting treatment, weekly fast days are very useful for diabetics; thin subjects stand the fasting treatment better than fat. One objection to the Allen treatment is the very restricted diet, which tends to inanition. Other diets allow more food, and the various vegetarian régimes have the advantage of making the patient (who is often ravenous) more satisfied; the bulk of food is much greater, and such a diet tends also to stimulate peristalsis. Oatmeal diet, used by some, is apt to cause oedema. Carbohydrate diets favour the accumulation of water, of carbohydrates and albumin, and lessen acidosis. Probably glycosuria is the only thing common to many so-called cases of diabetes, so that the individual metabolic defects of a series of cases may be widely different; hence the value of different diets. Whatever treatment is adopted, there is no doubt it should be started early, should entail a reduction in diet, should include days of fasting, and should recognize the utility of a vegetarian diet.

2. The Blood Pressure of Aviators.

E. GRANDJEAN (*Ugeskrift for Læger*, August 26th, 1920), using Fachon's sphygmometric oscilometer, has carried out blood pressure measurements on 28 aviators at an aerodrome in Denmark. The measurements were made immediately before and after flights, and the maximum blood pressure was found to be between 12 and 16 before flight and the minimum pressure between 8 and 10. Only in one case was the maximum pressure 17 and the minimum 11. In this connexion the author notes that in other countries the minimum pressure of candidates for aviation is kept within the bounds of 8 and 10. The measurements after flight bore no constant relation to measurements before flight: in 9 cases the maximum pressure had fallen, in 5 cases it had not altered, and in 14 cases it had risen. The effects of flight on the minimum pressure were more uniform: in 18 cases it had risen, in 8 cases it had remained unaltered, and only in 2 cases had it fallen. The author has compared these figures with measurements of the blood pressure taken after gymnastic exercises carried out just before flight. These exercises reduced the minimum pressure in 11 cases and failed to affect it in 14. Only in 3 cases did they increase the minimum pressure. The author concludes by suggesting that the explanation of many obscure aviation fatalities is to be found in arterial hypertension or vasomotor hypertonia, giving rise to giddiness, somnolence, and other dangerous symptoms.

3. Ocular Symptoms in Lethargic Encephalitis.

DAMENO (*Rev. Su I. Amer. di Endocrin.*, August 15th, 1920) made an ophthalmological examination of six cases of lethargic encephalitis with the following results: The optic nerve did not show any changes. The external or internal ocular muscles, and sometimes both, were affected. As a rule there was only a slight paresis, and in only one case was there a true paralysis; the oculo-motor nerve was the one most frequently affected. In no case did the lesion involve the whole nerve as in syphilis. The ocular movements were affected in two respects—namely, in limitation of their extent and in a diminution of their rapidity. No signs of affection of the sympathetic were found, even in three patients who showed vasomotor flushes of the face.

4. Blindness and Oxycephaly.

RATIÉ (*Journ. de méd. et de chir. prat.*, August 10th, 1920) states that the chief interest of oxycephaly is that it may be accompanied by ocular disturbances such as exophthalmos, nystagmus, strabismus, and especially optic neuritis. Operations which do away with endocranial hypertension, such as Fenbar puncture, ventricular puncture, or trephining, stop the progress of the neuritis, and if employed at the onset may prevent blindness. X rays often show at the base of the skull or in the sella turcica a deformity which causes a compression and deviation of the optic nerves. In addition to ocular symptoms oxycephaly often gives rise to headache, convulsions, vertigo, and olfactory disturbances. Idiocy and congenital dementia have been observed. The intelligence, however, is usually normal and even above the average, as in the cases of Paracelsus, Humboldt, Walter Scott, and Meckel. Blindness may occur without affection of the intelligence.

5. An Unusual Case of Mercuric Chloride Poisoning.

M. PFER (*Journ. Amer. Med. Assoc.*, September 4th, 1920) records the sequelae of the contraceptive use of a hastily prepared douche by which an almost entirely undissolved tablet of 7½ grains of mercuric chloride became lodged in the posterior vaginal fornix. Three hours afterwards the patient suffered from severe abdominal pain, nausea, vomiting, and syncopal attacks. Within thirty-six hours a black line appeared on the upper and lower gums; subsequently the teeth became loose, there was marked salivation, and the nasal mucosa sloughed. Three days after the douche was taken there was complete suppression of urine: four months afterwards the urine still contained albumin and casts. A large ulcer on the posterior portion of the cervix persisted for six weeks.

6. Adenitis in Herpes Zoster.

ACCORDING to RAMOND and LEBEL (*Bull. et Mém. Soc. Méd. des Hôp. de Paris*, August 5th, 1920) the primary adenitis of herpes zoster, which was first described by Barthélemy in 1892, presents the following characters: Its position is determined by the topography of the eruption, the axillary glands being affected in zoster of the upper limb and of the supra-umbilical portion of the trunk (this includes intercostal zoster), the inguinal glands in abdominal zoster and zoster of the lower limbs, the pre-auricular glands in ophthalmic zoster, the suboccipital in occipito-cervical zoster, the submaxillary and suprahyoid in superior or inferior maxillary zoster, and the superficial cervical in zoster of the neck. Like the eruption, the adenitis is unilateral. It appears at an early date, before any ulceration of the skin. Spontaneous resolution always takes place, and suppuration and chronic adenitis are unknown. Secondary adenitis in zoster is not a symptom, like primary adenitis, but a complication due to infection of the vesicles. It is relatively rare, is always a late event, and shows a tendency to suppurate. Uncomplicated herpes simplex and zosteriform eruptions are not accompanied by adenitis.

7. Early Diagnosis of Pulmonary Tuberculosis.

BOERI (*Rif. Med.*, August 14th, 1920) during the war saw many cases of phthisis among soldiers and prisoners of war, and contributes certain notes on the subject. He believes that sufficient attention is not paid to prophylaxis, especially with reference to careful watching of those predisposed. To recognize these subjects, in addition to the usual criteria he draws attention to the frequent existence in these people of the vertical hear and floating tenth rib; they usually suffer from neuro-muscular asthenia, dyspepsia, etc. Examination of the respiratory capacity is useful; a chest which, from the anatomical point of view, appears sound may be functionally feeble and may exhibit limited respiratory capacity (the reverse also holds good). Many of these predisposed subjects have a history of chest weakness. As additional helps towards the early physical diagnosis of phthisis, the author draws attention to lack of development of the edge of the trapezius and sternomastoid on the diseased side, together with hypertrophy on the sound side. Direct percussion of the clavicle should not be omitted. The exclusion of tubercle, when the signs seem to point to it, is sometimes difficult. Influenza often gives apical signs which are very suggestive, but change more rapidly than in tubercle. In all

the non-tuberculous apical affections the question arises whether these subjects are peculiarly vulnerable to apical disease, or whether it is simply a matter of environment and chance that these apices are attacked by tubercle, malaria, or influenza.

8. Treatment of Influenzal Pneumonia with Serum from Convalescents.

JACOBÆUS (*Svenska Läkartidningen*, April, 1920) has treated 70 cases of influenzal pneumonia with the serum of convalescents, giving, on the average, 40 c.cm. by intravenous or intramuscular injection. In fulminating cases and in the terminal stages of the disease this treatment was ineffective, but, adopted early, it seemed to prove beneficial in a certain number of cases.

9. Skin Eruptions in Influenza.

LEIMDÖRFER (*Wien. klin. Woch.*, August 26th, 1920) regards the skin rashes met with in influenza—like the eruptions on the buccal mucous membrane, tongue and throat—as an expression of a vascular lesion. In some cases an erythema may be observed chiefly affecting the trunk and only to a slight extent the limbs, disappearing in two days' time without leaving any desquamation. In six of Leimdörfer's cases a scarlatiniform eruption was seen, usually at the height of the disease. In a small number of cases there was an urticarial eruption affecting the forearms, hands, legs and feet.

10. Peripheral Neuritis in Tetany.

BETH (*Wien. klin. Woch.*, August 5th, 1920) records the case of a woman, aged 43, the subject of chronic relapsing tetany, who after lobar pneumonia had an acute attack of tetany, followed by right ulnar nerve paralysis, the most probable explanation of which was a mechanical lesion of the nerve due to the abnormal position of the hand.

SURGERY.

11. Tuberculosis of the Sclerotic.

COLLOMB (*Rev. méd. Suisse rom.*, October, 1920) reports the case of a patient with a small rounded very vascular tumour, definitely subconjunctival and situated on the sclerotic, and showing a tendency to invade the interior of the eyeball. The diagnosis was at first uncertain, lying between tuberculosis and syphilis, but was established by a positive inoculation of the eye of a rabbit. The growth was removed as completely as possible and energetic galvano-cauterization applied; recovery took place. Fietta in his Geneva thesis (1919), after excluding doubtful cases, could find only 13 examples of tuberculosis of the sclerotic on record. In every case the lesions were situated in the immediate neighbourhood of the cornea (10 cases) or of the optic nerve (3 cases)—that is to say, in the areas of the sclerotic supplied by the anterior or posterior perforating ciliary vessels. This form of tuberculosis is always secondary to another tuberculous focus in the organism. In the posterior pole of the eye it is probably more frequent than is supposed, and possibly several cases of so-called marginal tuberculosis of the optic nerve are examples of this kind.

12. Primary Tuberculosis of the Bladder.

ACCORDING to JUNGANO (*Journ. d'Urol.*, Tome X, No. 1, 1920), who records a case occurring in a woman aged 35, primary tuberculosis of the bladder was regarded as a condition of somewhat frequent occurrence; in pre-cystoscopic days it was hardly possible to determine the exact site of the disease. In a critical review of the cases published, Jungano concludes that one can only speak of primary tuberculosis of the bladder when disease of all the neighbouring organs has been excluded by an investigation including microscopical and bacteriological examination of the secretion of both kidneys and negative results of its inoculation into guinea-pigs.

13. Gonorrhoeal Peritonitis.

WILDENSKOV (*Ugeskrift for Læger*, September 23rd, 1920) has found 10 cases of gonorrhoeal peritonitis, verified by operation, in the records of the Nakskov Hospital in the period 1911-20. Most of the patients were young women, and the onset of the symptoms coincided, as a rule, with the termination of menstruation. In most cases the pain was confined to the lower abdomen, and was accompanied by muscular rigidity and, at a later stage, by meteorism. In some cases there was an effusion, with dullness. The

condition of the temperature and pulse showed no uniform characteristics. Tenderness on exploration was common, and was associated with mobility of the uterus. As a rule there was no obstruction to flatus, and recurrent attacks of diarrhoea were often recorded. In every case uncertainty of diagnosis led to expectant treatment, which was abandoned in favour of operative treatment when the symptoms failed to subside. Only one patient out of the ten died. Referring to the literature of the subject, the author finds that the mortality for operated cases is 16.6 per cent. (six deaths out of thirty-six operations), and for non-operated cases much higher. Indeed, all the nine recorded cases not operated on terminated fatally.

14. The Diagnosis of Gastro-colic Fistula.

CIVIDALI (*Il Policlinico*, Sez. Chir., October 15th, 1920) states that the first case of gastro-colic fistula was described by Haller in 1755. Murchison collected 33 cases in 1857, and now, including a case reported by Cividali himself, there are 106 on record. Cancer is the most frequent cause of the condition. Of Murchison's cases, 21 were due to this cause, 10 to gastric ulcer, and in 2 the origin was not determined. Of 95 cases collected by Port and Reizenstein, in 66 per cent. there was cancer of the greater curvature, pylorus, or transverse colon. The most important clinical symptoms from the diagnostic standpoint are the following: (1) Vomiting of faeculent matter; (2) frequent diarrhoea, which may become henteric; (3) impossibility of distinguishing the vomit from the faeces when the first two symptoms are present. Less important symptoms are: (1) Rapid loss of flesh; (2) sudden cessation of vomiting and supervention of diarrhoea in place of constipation; (3) faecal odour of the eructations and vomit; (4) possibility of inflating the stomach per rectum; (5) vomiting of substances introduced per rectum and recovery on washing out the stomach of colouring matter introduced per rectum; (6) presence in the faeces of colouring matter introduced by mouth before gastric digestion is complete; (7) discovery in the faeces of hydrochloric acid and pepsin. Pain is of no diagnostic importance, because it often occurs in a region distinct from that of the fistula.

15. Excision of the Patella for Congenital Dislocation.

ACCORDING to SWYNGHEDAUX (*Gaz. des Praticiens*, November 1st, 1920), who reports the successful employment of this measure in a girl aged 9, ablation of the patella, as first practised for dislocation by Fowler in 1871, has been rarely employed, although Berger obtained a perfect cure, as regards function of the knee, after excising the patella in a case of chronic osteitis. The cutaneous incision has its concavity directed upwards, and the periosteum is incised in a vertical direction. After removal of the bone the continuity of the quadriceps tendon and the ligamentum patellae is restored by means of silk sutures.

16. Mammary Hypertrophy treated by Subcutaneous Injection of Milk.

PATEL (*Journ. de méd. et de chir. prat.*, September 25th, 1920) reports a case of pathological enlargement of both breasts in a woman, aged 24, which developed after an attack of influenza. No diminution in size was produced by Bier's cups, cautery, or bandages. As Patel did not wish to amputate the breasts in so young a woman, he gave subcutaneous injections of woman's milk, as recommended by Weill and Mouriquand. Ten injections in all were given, one every ten days, in doses of 5 c.cm. at a time. On the fifteenth day the breasts began to diminish in size, and gradually assumed the appearance of deflated balloons. Histological examination of an excised portion showed that the tissue was that of a mammary gland in the resting state.

17. The Control of the Pyloric Sphincter in Man.

MCLURE, REYNOLDS, and SCHWARTZ (*Arch. of Internal Med.*, October 15th, 1920) give the results of fluoroscopic observations carried out in healthy adult human subjects. They conclude that finely divided carbohydrate, protein, or fatty foodstuffs begin to leave the normal human stomach within a few minutes after their initial ingestion. Under normal conditions the pyloric sphincter opens regularly at the approach of each antral peristaltic wave, allows chyme to pass into the duodenum during an appreciable length of time, and closes when the antral peristaltic wave has spent itself. Introduction into the first, second, and third portions of the duodenum of hydrochloric acid solutions diluted to one-tenth, one-twentieth, or one-fortieth normal, either produced no effect on the opening of the

pyloric sphincter, or produced effects which were interpreted as the result of an abnormal irritation of the duodenal mucosa. Neutralization of the contents of the first portion of the duodenum did not prevent closing of the pyloric sphincter. These results suggest that the theory of "acid control" of the sphincter, advanced by Pavlov and others, and elaborated by Cannon, is not applicable to man.

18. Sudden Death in Fractures of the Lower Limbs.

CHIBRAC (*Journ. de méd. de Bordeaux*, October 25th, 1920) in his Bordeaux thesis states that embolism is the essential cause of sudden death in fractures of the lower limbs. It may occur from the fifth to the ninety-fifth day after the fracture, the average time being from the eleventh to the thirtieth day. Two types of death may occur—a syncope form and an asphyxial form. Prophylactic treatment should be directed against thrombosis. If nothing can be done for the venous lesions already caused by the injury, fresh lesions may be prevented by proper reduction and immobilization, and great care must be taken when the time comes for massage and mobilization.

19. Glioma of the Nasal Fossae.

ANGLADE and PHILIP (*Rev. de laryng., d'otol., et de rhinol.*, October 30th, 1920) record the case of an infant, aged 3 days, whose right nostril had been obstructed since birth by a small red tumour projecting from the nasal orifice. Respiration was stertorous, and breathing and swallowing difficult. The tumour, which was the size of a kidney bean, was removed, with complete relief of the symptoms. A recurrence took place three months later, when the tumour was again removed, and applications of radium employed with success. Histological examination showed that the tumour was a glioma. The writers have found on record only four other cases of glioma of the nose; in two the tumour was situated at the root of the nose, and in the other two it was intranasal. Possibly, however, the condition is less rare than is supposed, for, in the first place, a large number of nasal tumours are removed without histological examination, and, secondly, the procedure required to demonstrate neuroglia is elaborate.

20. Chronic Trophoedema and Spina Bifida Occulta.

LÉRI and ENGELHARD (*Bull. et Mm. Soc. Méd. des Hôp. de Paris*, August 5th, 1920) record a case of chronic trophoedema of the right lower limb in a woman, aged 20, which had first appeared at the age of 13 and had assumed an ascending course without any disturbance of the general health or the slightest impairment of motor power, sensibility, or reflexes. The remarkable feature of the case was its association with a flattened prominence in the mid sacral region, measuring 7 cm. in its vertical and transverse diameters, and tender on pressure. X rays showed non-union of the posterior arches of the last three bony segments of the sacrum. The writers consider that the trophoedema was due to the spina bifida occulta, and that compression of the nerves of the cauda equina, and perhaps of the neighbouring venous plexuses, by a fibrous cord connected with the spina bifida accounted for the trophoedema.

21. Inflammation of Meckel's Diverticulum.

ACCORDING to LEHMANN (*Wien. klin. Woch.*, September 30th, 1920), who records an illustrative case in a woman aged 39 successfully treated by operation, isolated inflammation of Meckel's diverticulum is uncommon, only 17 cases (including two personal ones) having been collected by Stern. The causes of the condition vary. In several cases foreign bodies are responsible. In one case, in addition to a foreign body, a faecal concretion was present. In another case there was a degenerating sarcoma, and in two others adhesions and rotation on the long axis of the diverticulum were the causes of the inflammation.

22. Statistics of War Surgery.

DE FRANCISCO (*Il Policlinico*, Sez. Chir., October 15th, 1920) states that from August 15th, 1915, to February 28th, 1919, 2,216 cases of war wounds were treated at the Lodi Military Hospital. The most frequent wounds were those inflicted by rifle or machine gun bullets (39.57 per cent.); then came shell wounds (31.45 per cent.), shrapnel wounds (16.5 per cent.), and bomb wounds (7.76 per cent.). Trench mortars were responsible for 27 cases, revolvers for 7 cases, aeroplane bombs for 4 cases, and stone throwing for 45 cases. Only 6 cases were due to bayonet wounds. The regions affected in order of frequency were the lower limbs (38.71 per cent.), upper limbs (29.87 per cent.), head

and neck (13.22 per cent.), trunk (11.01 per cent.), several regions simultaneously (6.85 per cent.). The external genitals were affected in seven instances only. The most frequent complications were bony lesions (20.03 per cent.), visceral lesions (3.61 per cent.), severe septic complications (2.70 per cent.), joint lesions (2.34 per cent.). There were 27 cases of lesions of important vessels and nerves, in 9 attended with shock; 599 operations were performed with 34 deaths, a mortality of 5.67 per cent. The total mortality among the 2,216 cases was 52 cases, or 2.34 per cent.

OBSTETRICS AND GYNAECOLOGY.

23. The Insertion of the Round Ligaments and Diagnosis of Impending Rupture of the Uterus.

ACCORDING to AUER (*Zentralbl. f. Gynäk.*, September 18th, 1920), the statement has been made that observation of the relation between the points of insertion of the round ligaments into the uterus may afford evidence of existing or threatened rupture of the uterus; when the line (normally horizontal) joining these two points of insertion becomes oblique, or when this line, although remaining horizontal, becomes displaced upwards and reaches above the umbilicus, stretching of the lower uterine segment, and, therefore, rupture of the uterus must, it has been said, be suspected. Auer, from an examination during labour of 71 one-parae and 29 multiparae, concludes that this sign has little importance. In 36 cases the round ligament insertions were found to be below the umbilicus; in 36 cases these ligaments were found to be inserted above the umbilicus on both sides, and in 28 cases on one side. The line joining the insertions was transverse in 37 cases and oblique in 63.

24. Castration for Uterine Fibroma.

DE ROUVILLE (*Gynéc. et Obst.*, 1920, i, 5) believes that Hégar's operation of double ovariectomy has still a definite though limited application in cases of uterine fibroids with haemorrhage. Hysterectomy is the operation of choice, but in patients whose general health has been profoundly affected by haemorrhage it may be that castration can be performed much more rapidly. Hégar's method was found in 1888 to lead in 80 per cent. of the cases to satisfactory haemostasis. Tédénat adopted this treatment 29 times from 1887 to 1897, with 27 successes; from 1908 to 1914 he performed Hégar's operation 6 times in cases in which hysterectomy appeared to be contraindicated by the patient's grave anaemia. De Rouville records 6 personal cases attended with satisfactory results. In a seventh menorrhagia returned eight months after the operation; the patient's general health being much improved, hysterectomy was performed, and it was demonstrated that on both sides a cystadenomatous change had supervened in ovarian fragments left behind at the first operation. It is suggested that when castration is not followed by disappearance of the haemorrhages, ovarian tissue has invariably been left behind.

25. Premature Separation of the Normally Situated Placenta.

ACCORDING to KOTZAREFF (*Schweiz. Rundschau f. Med.*, 1919, 17) 15 cases of this condition were observed among 8,000 births occurring in twelve years at the Genfer Klinik. One case only was fatal, death being due to embolus of the right pulmonary artery. BITSCHIN (*Ibid.*, 16 and 17) describes five cases observed at the Berner Klinik; one mother and three children died. Resort was not had to plugging; three cases were treated by transperitoneal cervical, and two by abdominal Caesarean section. The etiology of three was uncertain; in one case the patient suffered from chronic nephritis, and in the other the history was suggestive of lues.

25. Hydrops Foetus Universalis.

ACCORDING to FLAMMA (*Ann. di Ostet. e Ginec.*, June, 1920) this is a rare condition, not more than eighty cases having been published, although examples have been recorded since the end of the seventeenth century. In Flamma's case the mother was a healthy woman, aged 40, who had had five previous pregnancies. The sixth pregnancy terminated about the eighth month with the birth of a female infant, which died shortly afterwards, showing considerable oedema of the face, scalp, and upper part of the trunk, and slight oedema of the limbs. The necropsy showed congenital malformation of the heart dating from the first weeks of intrauterine life. The left auricle was hypoplastic, the pulmonary arteries were

enormously dilated, the ductus arteriosus was as large as the aorta, and there was free communication between the ventricles. Flamma concludes that hydrops foetus universalis is due to a single mechanical cause—namely, obstruction to the circulation, the obstruction being due to malformation or tumours in the principal foetal organs and their appendages or to naked eye and microscopical lesions in these organs caused by toxins transmitted from the mother. All cases of foetal dropsy are associated with hydranmios, as in Flamma's case, and pregnancy should be interrupted at an early stage.

27. Vaginal Preparation for Extended Hysterectomy.

IN consequence of the deterioration of the quality of benzine during the war, ELGART (*Casopis lékařův českých*, 1919, 35, quoted in the *Zentralbl. f. Gynäk.*, September 11th, 1920) was unable to perform cauterization in extended abdominal hysterectomy. In cases where the portio vaginalis was unaffected he occluded it by stitch and suture. Where this region was the seat of a growth he split the vagina into two halves by means of a circular incision. The upper half was prepared in a sleeve-like fashion, and was made to cover the cervix during the removal of the extirpated parts. This method is stated to have the advantage that the preliminary vaginal operation will disclose any existing extension of the growth to the bladder; the impossibility of abdominal extirpation is thus recognized, and coeliotomy is not undertaken.

28. Vaginal and Cutaneous Diphtheria.

LENDEERTZ (*Med. Klinik*, 1920, No. 6) records the case of a child of 5, who, shortly after the death of two sisters from diphtheria, was suddenly seized with pains on urination. The neck and nose were normal, but there were reddening and swelling of the vulva and vagina, and an impetiginous condition of the mons veneris; later, infiltrated, ulcerated swellings were found in the coccygeal and gluteal regions, and the vaginal inflammation became definitely membranous. The inguinal glands were swollen and painful; diphtheria bacilli were found in the cutaneous and genital lesions. During convalescence paresis of the palate and of both abducent and both oculo-motor nerves was noticed, together with urinary and faecal incontinence.

29. Vaginal Cyst probably of Wolffian Origin.

THIÈRE and LAZARIDÈS (*Bull. et Mém. Soc. Anat. de Paris*, July, 1920) report the case of a woman, aged 26, who ten days after confinement began to suffer from abdominal pain, most marked in the right iliac fossa. Vaginal examination showed a rounded painless swelling, the size of a hen's egg, attached by a broad pedicle to the vaginal wall close to the cervix. The cyst, which contained a thick yellow fluid, was extirpated under general anaesthesia, and was found to be lined with cylindrical epithelium. The wall, which was formed of connective tissue and muscle, was infiltrated with a few polymorphonuclears and numerous mast cells, indicating a certain degree of subacute inflammation.

30. Syphiloma Vulvae.

STEIN (*Surg., Gynec., and Obstet.*, September, 1920) records two cases of this condition occurring in coloured women aged 20 and 22 respectively; the Wassermann reaction was positive in both. The author believes that the names *esthiomène* and *lupus vulvae* should no longer be employed, and that *syphiloma vulvae* correctly designates the disease as a manifestation of tertiary lues. In view of the long-standing character of the specific infection in the majority of cases, it is not to be expected, it is said, that the Wassermann test should be invariably positive. The treatment should consist of operative removal of all tumours, hypertrophied tissues and ulcers, followed at the same session by cauterization, and combined with intensive antisyphilitic medication.

31. Pedicular Torsion in Ovarian Cysts.

KIOLBASSA (*Zentralbl. f. Gynäk.*, September 11th, 1920) records 24 cases of pedicular torsion among 328 cases of ovarian cyst (7 per cent.). The condition was most frequent between the ages of 40 and 45, and was more common among multiparae. No death occurred among this series of cases, which were treated by immediate laparotomy and removal of a tumour after application of several ligatures to the pedicle. The condition appeared to be equally common on both sides, and was encountered four times more frequently in benignant than in malignant cysts.

PATHOLOGY.

32. Pneumococci in Throats of Normal Persons.

A STUDY was made by MEYER (*Journ. Amer. Med. Assoc.*, November 6th, 1920) on 100 normal individuals of varying ages, in whom no history of contact with an acute or recent case of lobar pneumonia could be obtained. Pneumococci were found in twenty-one instances; Types I and II were not found in any case. Type IIA was isolated once; Type III occurred in three instances, and Type IV in seventeen. The organism identified as Type IIA by the precipitin method was soluble in bile, but did not ferment inulin. Of the seventeen strains of pneumococci Type IV, eight were apparently more readily soluble in bile than the remaining nine. As the diagnosis of this group largely depends on the bile reaction, the bile test was repeated. All seventeen strains were found bile-soluble, but the results did not correspond closely with those obtained when the organisms were first isolated. Attention is called to the difficulty in differentiating colonies of pneumococci from colonies of *Streptococcus viridans*. It is, therefore, Meyer says, quite likely that the variations in the percentage of pneumococcus Type IV found in normal persons may be due to difficulties of differentiation between pneumococci and green-producing streptococci.

33. The Action of Bile on the Spinal Centres.

ROSSI (*Arch. per le Sci. med.*, vol. 43, Fasc. 3-4, 1920), as the result of his experiments, found that injections of bile and bile salts into the veins and serous cavities have a depressing action on the central nervous system both of frogs and of mammals. It is only when it is injected into the carotid in large doses, or when it is brought into direct contact with the nerve centres, that bile can give rise to symptoms of motor excitement, represented by tetanic spasms, convulsive attacks, nystagmus, disorderly movements, etc. In this connexion it may be noted that states of excitement have been observed clinically in jaundice, and, experimentally, after ligation of the common bile duct in animals. In such cases, however, the phenomena of excitement may be due to special products of altered hepatic metabolism rather than to bile.

34. Congenital Paroxysmal Cyanosis.

PEHU and LANGERON (*Lyon Méd.*, November 5th, 1920) record the findings made at autopsy in a child which since birth had suffered from paroxysmal attacks (of which one proved fatal) of cyanosis, associated with intense dyspnoea, lasting as long as forty-five minutes. Physical examination during life had shown only an inconstant systolic murmur, unrelated to the incidence of the attacks. The right ventricle was found to be hypertrophied and the aorta to be dilated; the pulmonary artery was atrophic. The ductus arteriosus was obliterated, but the inter-ventricular septum was imperfect.

35. The Properties of Histidin.

HANKE and KOESSLER (*Journ. of Biochemical Chemistry*, Baltimore, September, 1920) describe the preparation of histidin from blood corpuscle paste, and give an account of a calorimetric method by which quantities as small as 0.1 mg. can be estimated in either the presence or absence of protein. Casein, which contains a depressor substance pharmacologically similar to histidin, could not by this method be shown to contain this substance. The cerebral hypophysis of the ox, if perfectly fresh, did not contain histidin. Typical peptone shock could be obtained by injection of a peptone that was free from histidin.

36. A Microchemical Test for Ammonia.

ACCORDING to DENIGÈS (*Pharmaceutical Journ.*, October 2nd, 1920), if a very small drop of 10 per cent. aqueous solution of iodic acid is exposed for a few seconds on the tip of a glass rod to the vapour of ammonia, minute characteristic cubical crystals are formed. In very small quantities of ammoniacal salts and solution the ammonia can be detected in the following way: Take a short glass tube about 3 to 4 cm. long and 15 to 16 mm. wide, with the edge bent outwards so that it can be supported by the rim in a small flask. The solution to be tested is evaporated to about 1 c.c., placed in the tube, and 0.5 gram of calcined magnesia added. A microscope slide on which has been spread out a drop of 10 per cent. iodic acid is allowed to stand, inverted, above the tube. If the solution contains 1 mg. of an ammonium salt, the crystals will appear in a few minutes; with 0.1 mg. in about an hour.

EPITOME OF CURRENT MEDICAL LITERATURE.

MEDICINE.

37. Transient Acute Poliomyelitis in the Adult.

CICCARELLI (*La medicina pratica*, August 31st, 1920) records a case of transient acute poliomyelitis following influenzal bronchopneumonia in an adult, and characterized by complete loss of power in the lower limbs, abolition of the knee-jerks, absence of sensory changes, integrity of the sphincters, and wasting of muscles. A diagnosis of acute poliomyelitis of the lumbo-sacral segment of the cord was made owing to the sudden onset, rapid development, and degenerative character of the paralysis. Gradual improvement took place, so that by the end of four months the patient could walk three kilometres with the aid of a stick.

38. Modern Methods of Treatment in Pulmonary Tuberculosis.

VALLARDI (*Tuberculosis*, August, 1920) alludes to treatment by certain metals—for example, copper, gold, nickel, cobalt—which *in vitro* have been shown to have a marked predilection for tubercle bacilli. For the present this line of treatment is on its trial. Next he discusses the efforts to produce active immunization by tuberculin preparations, etc. It is better to begin with specific treatment by tuberculin; after the maximum degree of resistance to the poisons of the tubercle bacillus has been determined, one may continue with bacillary emulsions. The great difference in patients' reactions to tuberculin may be partially explained by remembering that tuberculin is a mixture of variable substances, and that each patient has an individuality which may change. Rapid forms of phthisis, or cases in which there is much congestion and tendency to frequent haemorrhage, are unsuitable for tuberculin treatment. Haemoptysis alone is not a contra-indication. Attempts at passive immunization are represented by the various serums—for example, Maragliano's or Marmorek's. There is a danger in long-continued serum treatment of the formation of anti-antitoxins, which assist in the development of the disease. Where tuberculin is contraindicated, the so-called immune bodies introduced by Spengler in 1908 may be useful. Artificial pneumothorax is favourably spoken of as arresting the disease, stopping haemorrhage, and checking the spread of toxins into the lymphatics. Radiography shows that the apparent obliteration of cavities by this method is not as real as it seems. Pleural adhesions and bilateral tuberculosis are the chief contraindications; cases with heart disease, marked pulmonary emphysema, and enteroptosis are also unsuitable. Cases with localized ulceration, tendency to caseation and frequent haemoptysis are suitable. Enough gas should be introduced to obtain a weak positive pressure; usually four to six introductions are necessary to reach the 1,700 to 3,000 c.cm. required. As a rule the pneumothorax should be maintained for two years.

39. Syphilis simulating Pulmonary Tuberculosis.

SÖRENSEN (*Hospitalstidende*, September 1st, 1920) has seen in Java as many as seven cases of pulmonary syphilis simulating phthisis. A feature common to almost all these cases was the absence of physical signs over the apices of the lungs; elsewhere they seemed to be riddled with disease, and the clinical picture was typical of pulmonary tuberculosis in the last stage. The author was at first inclined to regard this pulmonary manifestation of syphilis as more or less peculiar to the tropics, but during a recent stay in Holland he observed a similar case in a woman suffering from "phthisis" and osteitis of the forehead. Under anti-syphilitic treatment the pulmonary disease cleared up even more rapidly than the osteitis. In several of his cases the author could find no history of syphilis, although his patients were perfectly candid as to their past. There was also, in some cases, no other clinical evidence of syphilis than the chest signs. His evidence for regarding the pulmonary condition as syphilitic was a positive Wassermann reaction, absence of tubercle bacilli in the sputum, and amazingly rapid improvement, and in some cases complete recovery, after the institution of anti-syphilitic treatment. The author also recalls two cases of persistent fever simulating typhoid fever in which the intramuscular injection of mercury reduced the temperature to normal within two days.

40. A Case of Syphilitic Aortitis.

MARCIALIS (*Rev. Osped.*, August 31st, 1920) remarks that when a cardiac affection has reached the final stage, it is often difficult to diagnose during life the exact nature and seat of the affection; the physical signs are confused, and the clinical picture is due to the final anatomical lesions and not to the pre-existing ones. Cardiac failure is not always the result of a valvular defect but may be due to any cause, even an extracardiac one, when the reserve energy of the heart is exhausted. Marcialis records the case of a man, aged 42, who on admission to hospital showed typical signs of cardiac failure, including cyanosis, dyspnoea, hydrothorax, and oedema of the lower limbs. He had contracted syphilis at the age of 20, and four months previously had had an attack of transient hemiplegia. The Wassermann reaction was positive. Considerable relief followed thoracocentesis, but death took place suddenly the following day. The autopsy showed large raised fibrous patches at the origin of the aorta, one of the patches completely occluding the origin of the left coronary artery. The left ventricle was dilated and the right hypertrophied.

41. Prognosis in Syphilis.

MONFRINI (*Rev. méd. Suisse rom.*, September, 1920) maintains that it is impossible to form a sound prognosis in the treatment of syphilis without making an examination of the cerebro-spinal fluid; in old cases of syphilis, especially when the nervous system is affected, the Wassermann reaction may be negative in the blood when it is positive in the cerebro-spinal fluid. He records a case in a man, aged 40, who, in spite of vigorous treatment and a negative Wassermann reaction in the blood, eighteen months after the onset of syphilis and five weeks after the last injection of "606," suddenly developed symptoms of meningo-encephalitis which might have been prevented had a lumbar puncture been made when the blood was examined for the Wassermann reaction.

42. Parathyroid Tetany in Infancy.

CLARK (*Glasgow Med. Journ.*, October, 1920) describes two instances, occurring in infants, of what he regards as parathyroid tetany, similar to that which develops in animals after the removal of these glands. The patients were aged 15 months and 2½ years respectively. The outstanding symptoms were idiocy, with depression and apathy, fibrillary twitchings in the muscles, a staring appearance of the eyes, jerking movements of the limbs, inability to balance, a tendency passively to preserve unusual positions in which the subjects had been placed, and frequent convulsions. Treatment with dried parathyroid gland substance (one-tenth of a grain thrice daily) caused immediate improvement; one child appeared to be completely cured and the other gradually improved. In one case the gland substance was discontinued twice, and on both occasions the child was not so well, but recovered as the administration was resumed. In neither case was there impairment of nutrition; carpopedal spasm or Trousseau and Chvostek phenomena were not observed.

43. Acrobrachycephaly.

PARK and POWERS (*Amer. Journ. of Diseases of Children*, October, 1920) print abstracts of the history of 24 cases, and add the record of a personal case of so-called "acrocephalosyndactylism," or acrobrachycephaly—a disease characterized by unusual configuration of the cranium, together with malformations of the extremities. They also report two cases of scaphocephaly, with malformations of the extremities. Of the 25 subjects of the first-named deformity, 11 were less than 18 months old, and 6 were newborn infants; the oldest was 24 years. The most important characteristics of acrobrachycephaly are as follows: The head is abnormally high, short, and broad, its vertical diameter being greatly increased by an abnormal extension upwards of the cranial vault, and the occiput being flattened so that in some cases the back of the head is flush with the neck, and the surfaces of the face and of the back of the head are almost parallel. The angular process of the frontal bone, and the zygomatic arches are unusually prominent, and the forehead is of abnormal height and breadth. The palpebral apertures are set obliquely, so that their transverse axes are inclined outwards and slightly downwards. The eyes are prominent, sometimes to a very pronounced extent, so that in one

case manual replacement of a dislocated right eyeball was necessary on eleven occasions. The facies is that of chronic nasal obstruction, and almost invariably there is a narrow and high palate; in five cases the hard palate was partially cleft, and in six the uvula was bifid. The deformities of the hands range from complete syndactylism, in which the fused fingers, thumb, and body of the hand form a spoon-shaped mass, concave on the palmar surface, to minor conditions of partial syndactylism or other deformities affecting one or two digits. The toes show similar appearances, and hallux varus is invariably present. In certain cases there is limitation of movement at the elbows, shoulders, or wrists. The intelligence may be normal or subnormal, and walking as a rule is begun about the eighteenth month. Syphilis appears to play no part in the etiology. The authors are inclined to believe that the malformation of the skull is in existence, in a potential sense at least, in the blastemal cranium.

44. Senecio Poisoning.

WILLMOT and ROBERTSON (*South African Med. Record*, September 25th, 1920) record preliminary investigations of "senecio disease," prevalent in the George and Mossel Bay districts of the Cape Province. The malady begins with slight symptoms of digestive derangement, followed by abdominal pain, diarrhoea, haematemesis, melaena, enlargement of the liver, and ascites; acute as well as chronic forms are found. Albertyn suggested, in 1918, that the disease was of dietetic origin, and samples of meal and white bread which had been eaten by persons affected were found to be contaminated with the seeds and other portions of the plants *Senecio ilicifolius* and *Senecio burchellii*. Willmot and Robertson found that in acute cases the liver was enlarged, with rounded edges, and raised, engorged areas, the size of a hazel nut or walnut, projecting on the surface. More advanced cases showed round-celled infiltration and hepatic cirrhosis. Guinea-pigs and white rats fed on infected meal or on the dried flower heads and seeds of senecio became emaciated, and many died; the *post-mortem* findings were exactly similar to those made in human subjects.

45. Disturbance of Deglutition in Aortic Disease.

ACCORDING to NICOTRA (*Il Policlinico*, Sez. Prat., August 30th, 1920), x-ray examination shows that the disturbances of deglutition in aortic disease are not due to the mechanical action of pressure on the oesophagus, but are caused by a motor neurosis secondary to degeneration of the nerve fibres of the oesophagus and pharynx. In all such cases antisyphilitic treatment is indicated.

SURGERY.

46. Coma after Injury of Frontal Lobes.

MILIAN (*Paris méd.*, October 2nd, 1920) records the case of a girl, aged 20, who shot herself in the head, the bullet passing through the anterior part of the frontal lobes. The Rolandic area was not affected, as there was no hemiplegia or monoplegia. In addition to left facial paralysis and right internal squint due to fracture of the petrous portion of the temporal bone, the patient presented a comatose state, the remarkable feature of which was its close resemblance to ordinary sleep. There appeared to be a pure and simple suspension of the intellectual faculties. There was no stertor, Cheyne-Stokes breathing, or other respiratory anomaly. Respiration though weak was regular and not hurried, and the pulse, though small, was also regular and not rapid. Although there was incontinence of urine, sensibility remained almost normal, as was shown by defensive movements on the application of painful stimuli, just as in ordinary sleep. The corneal reflex was present on both sides. The temperature never rose above 101.8 F. Apart from a slight squint complete recovery took place.

47. Treatment of Osteomyelitis with Antistaphylococcal Vaccine.

BOUVIER (*Gaz. hebdom. des Sci. méd. de Bordeaux*, October 10th, 1920) records a case of osteomyelitis of the left tibia in a man who was operated on first at the age of 35 and later at 50. Since on the second occasion the wound was very slow in healing and pustules containing staphylococci appeared in the neighbourhood of the wound, a subcutaneous injection of Le Moignic's antistaphylococcal lipovaccine was given. Complete recovery took place within two and a half months, as compared with seven months after the first operation.

48. Medical Treatment of Incipient Cataract.

SCALINCI (*Rif. Med.*, September 18th, 1920) pleads for a more extended use of medical treatment in early cataract. He assumes that the disease is in some way related to nutrition; any discoverable cause should be treated, but in addition benefit can be derived from the use of iodides, internally and locally. Inasmuch as iodine can be recognized in the aqueous humour very shortly after oral administration, there is perhaps not much extra benefit to be derived from local administration, whether by ointment, local baths, cataphoresis or subconjunctival injection (the author prefers sodium iodide with the addition of a small quantity of calcium phosphate). Obviously not every cataract, nor any cataract at an advanced stage, is susceptible of benefit from the iodide treatment, and the decision must be left to the ophthalmic surgeon. Dor says that he can arrest 8 out of 10 cases of cataract by this treatment, thus avoiding operation. The treatment should be continuous for at least three to six months.

49. Treatment of Furuncle of the Lip.

LANZ (*Nederl. Tijdschr. v. Geneesk.*, December 4th, 1920) emphasizes the danger of incising a furuncle of the lip by relating how two of Kocher's assistants at Berne died of pyaemia due to this cause. He urges that furuncle of the lip should be treated from the first as a serious disease. The patient should be put to bed and prevented from scratching or pressing his lip. Conservative treatment should be adopted in the form of poultices or dressings of 1 in 1,000 salicylic acid. Instead of an incision the necrotic centre of the pustule should be punctured with a thermo-cautery, or preferably a galvano-cautery. While the knife opens up the blood and lymph channels the thermo-cautery closes them, and thus diminishes the danger of infection of the blood stream.

50. Mastitis in Malta Fever.

BENEDETTI (*La Clinica Chirurgica*, March-April, 1920) records a hitherto undescribed complication of Malta fever. The patient was a woman, aged 52, who developed a chronic suppurative mastitis of the left breast in convalescence from Malta fever of three months' duration. Histologically the inflammatory infiltration was constituted by leucocytes which were almost exclusively of the mononuclear type. This mononucleosis in the inflammatory processes of Malta fever is due to the morphology of the blood in that disease, and serves to distinguish it from the inflammatory processes due to ordinary pyogenic organisms. Mononucleosis in infectious diseases is rare, the only other diseases in which it is found being chronic malaria, kala-azar, and the second stage of typhoid fever.

51. Intestinal Perforation in Typhoid in Childhood.

GIOSEFFI (*Rif. Med.*, October 16th, 1920), in view of the rarity of such accidents in childhood, reports the case of a girl, aged 14 years, who on the tenth day of an attack of typhoid fever was seized with sudden pain in the right lower abdomen. On the following day, as there were signs of rigidity on the right side of the abdomen and the general condition was worse, perforation with subsequent peritonitis was suspected, and laparotomy performed. On opening the abdomen pus and gas escaped, and there was evidence of recent peritonitis with adhesions and flakes of lymph. The peritoneum was washed with physiological solution and a drain inserted. Widal's test was positive at this date, and Eberth's bacillus grew in blood culture. The child made an excellent recovery.

52. Simple Perforating Ulcers of the Caecum and Colon.

CHARBONNEL (*Gaz. hebdom. des Sci. méd. de Bordeaux*, October 10th, 1920) records a personal case, and has collected 5 others from the literature, of simple ulcers of the caecum or colon, for which no local or general cause—such as dysentery, tuberculosis, or actinomycosis—could be found. Charbonnel attributes their occurrence partly to infection from faecal stasis and partly to circulatory disturbances in the caecum. The ulcer has a punched-out appearance, with its margins slightly, if at all, indurated. It is usually single, but is sometimes accompanied by one to three smaller perforations situated on the anterior surface of the caecum and colon. The appendix is always healthy. Histological examination shows ordinary inflammatory changes and vascular lesions consisting in haemorrhagic infiltration.

53. Congenital Occlusion of the Small Intestine.

ROCHET and WERTHEIMER (*Lyon Chir.*, September-October, 1920) record three cases of this condition, two of which were found in infants who died five and fifteen days respectively after birth, and one in an anencephalous foetus who presented numerous congenital malformations. Congenital malformations of the intestine may vary in number and position. They may be multiple, but are as often single, as in two of the writers' cases, and occur most frequently in the duodenum, jejunum, and upper part of the ileum. The part of the alimentary canal below the lesion shows atrophy and arrest of development, although occupying a normal position, so that in a full term child the size and calibre of the intestine are those of a four months foetus.

54. Torticollis.

AIEVOLI (*Rif. Med.*, October 16th, 1920), in a review of recent knowledge concerning wry-neck, points out the difficulty of determining the exact cause. Although it is usually classified as congenital or acquired, it is doubtful how many of the so-called congenital group are really congenital (out of 95 cases in a Milan hospital 78 were classified as congenital). Some of these congenital cases are perhaps due to obstetric injuries. Females are more often affected than males, and more often on the right side, males slightly more often on the left side. The torticollis may be sternal, clavicular, or total, according to the parts of the sterno-cleido-mastoid chiefly affected. The pure clavicular type is often associated with abnormal history; the types associated with cranio-facial deformity or with spinal curvature must be considered separately. For treatment open operation is generally practised, but in some cases where a small scar is desired, a subcutaneous tenotomy may be sufficient. After operation some form of extension and counter-extension is necessary.

55. Dead Grafts for Tendon Repair.

DURAND (*Lyon Méd.*, October 25th, 1920) in three cases has restored the continuity of the divided tendons of the digital flexors or extensors by using dead grafts taken, according to Nageotte's method, from tendons of ox embryos. Directly after slaughter of the cow the tendon is removed, with aseptic precautions, from the foetus, and preserved for eight to ten days in 90 per cent. alcohol, and afterwards in 60 per cent. alcohol. The graft may be kept sealed in this medium for several months. After operation the member is immobilized for ten days in a position which will relax the tendon concerned. In Durand's three cases the presence of the graft was well borne, but in one no restoration of function followed.

56. Cerebral Hydatid Cyst.

CARDENAL and CASTELLÀ (*Rev. Españ. de Med. y Cir.*, September, 1920) record the case of a boy aged 14 who suffered from epileptic attacks which had progressively increased in frequency from the time of a fall which occurred a year previously. This fall had caused a wound of the right parietal region and two hours' loss of consciousness, and had been succeeded by six weeks' pyrexia. Admitted to hospital, he was found to have right hemiparesis, with exaggerated reflexes, but no impairment of intelligence nor abnormalities of the fundus oculi. A flap of scalp and cranium was turned back in the left parietal region (the opposite side to that of the injury); opening of the dura exposed a cystic cavity (containing numerous daughter cysts) occupying more than one-third of the left cerebral hemisphere. The daughter cysts and the internal lining membrane were removed and a gauze drain was inserted. The fits disappeared from the sixth day after operation; subsequently, with the exception of some rigidity of the arm, the hemiparesis disappeared.

57. Hydatid Cyst of the Renal Pedicle.

ACCORDING to DEMOULIN (*Journ. de Méd. et de Chir. Prat.*, October 10th, 1920), the kidney comes next to the liver and lung in the order of organs liable to become the site of hydatid cysts. Of 2,111 hydatid cysts reported by Houzel, 115 occurred in the kidney. The diagnosis of the hydatid nature of the cyst is very difficult as long as it remains closed. Outbreaks of urticaria may arouse a suspicion, which is confirmed by laboratory examinations, especially eosinophilia in the blood and urine. When once the cysts have burst into the renal pelvis, the association of pain with an urticarial eruption, and the thick blood-stained urine containing hydatid cysts reveal the nature of the

case. Exploratory puncture, which is an excellent method in cysts of the liver, is dangerous in the case of the kidney; for treatment, nephrotomy by the translumbar route, with drainage of the hydatid cavity, is the method of choice. In some cases nephrectomy combined with a dissociation of the renal pedicle may be required.

OBSTETRICS AND GYNAECOLOGY.**58. Incubation-Chamber Treatment of Premature or Very Small Infants**

HAUCH and RUGE (*Gynéc. et Obstét.*, 1920, ii, 2) describe the treatment of newborn infants weighing less than 2,050 grams at the Righospitalet, in Copenhagen, where instead of portable "incubators" a large chamber is installed, in which the children remain continuously for some weeks, and in which nursing attentions and, if necessary, maternal feeding may be given. In nine years, among 13,425 births at the clinic, there were 521 instances in which the child weighed less than 2,050 grams; of these 521 infants, 145 were born dead, and 114 died within twenty-four hours. Of four infants weighing less than 1,200 grams, three died; of 51 weighing 1,200 to 1,499 grams, 10 died; of 207 infants weighing 1,500 to 2,050 grams, 24 died. For all degrees of smallness of the infant, the percentage mortalities are much lower than those reported by Crédé, Henry, Badin, Porak-Durante, or Liechtenstein. Hauch and Ruge attribute the low mortality at the Righospitalet to the use of large incubating apartments in preference to small portable incubating cradles. In common with other authors they recommend that washing of these newborn subjects should be deferred for from twenty-four to forty-eight hours; the body temperature is then found to be maintained at a much higher level than if the usual ablutions are performed shortly after birth. Another factor in the reduction of mortality in the clinic is careful isolation of babies showing signs of febrile catarrh, pneumonia, or pemphigus. As a rule the infants are fed with human milk; if this is impossible, with a mixture of cow's milk and barley water. Three hourly feeds during the day and a single feed during the night are recommended; if, however, the infant does not progress the intervals between the feeds are reduced to two hours. Collapse and cyanotic crises are treated by baths, artificial respiration, and hypodermic injections of 0.5 to 1 c.cm. of camphorated oil, or of digalen. Two cases only have been encountered in which infants born before the twenty-eighth week survived; both were born spontaneously of healthy mothers, and the respective weights were 1,150 grams and 1,250 grams. Only in 59 cases was it possible subsequently to trace the fate of these infants; of these 59 children, 71.2 per cent. were living at the end of one year. The average mortality rate in Copenhagen from 1907 to 1917, for all children born alive, was 10.6 per cent. during the first year.

59. An Operation for Complete Perineal Tear.

IMBERT (*Amer. Journ. of Surg.*, September, 1920) illustrates an operation which he has devised for complete tear of the perineum. A transverse incision is made, extending about 6 cm. on each side of the middle line, and separating the valva from the anus. A flap of the mucous membrane is dissected from the vagina and removed; the vaginal and anal gaps are sutured edge to edge, and the rectal mucosa, if it has been torn, is sewn. The lozenge-shaped gap which is left between the valva and anus, in correspondence with the original transverse incision, is filled in by a lateral flap (whose attached base is anterior, and pointed free end posterior) taken from the skin and subcutaneous fat of the buttock.

60. Obstetrical Fracture of the Femur.

LE GRAND (*Gynéc. et Obstét.*, 1920, i, 6) describes a new method of continuous extension for obstetrical fracture of the femur. Continuous extension is applied to both thighs, which are maintained in a position of extreme abduction at the hip. A single padded splint is required, consisting of a rectangular piece of wood the length of which exceeds by a few inches the distance between the lower extremities of the two maximally abducted limbs. Traction is secured by placing beneath this splint an elastic band, the extremities of which are turned over at the end of the splint, where they are connected to the loops of strips of plaster, which (attached at one end to the outer side of the thigh) pass along the side of the limb, below the foot, and upwards again, to be fixed on the inner aspect of the thigh.

61. Vesico-uterine Fistula.

BRODHEAD (*Med. Record*, September 11th, 1920) records the case of a sixth normal spontaneous delivery lasting six hours, followed after three days by abdominal pain, fever, and disturbance of micturition. Subsequently the patient became incontinent, and blood-stained urine was found escaping from the cervix; a large fistulous connexion was seen between the bladder and cervix. This closed within a few days. It is recorded that ten minutes before birth the patient received a hypodermic injection, probably of pituitary extract.

62. Pregnancy and the Thyroids.

ALBECK (*Gynec. et Obstet.*, ii, 1) interrogated 1,707 pregnant women, of whom 1,157, or 67.78 per cent., had suffered from severe vomiting. Of 358 who were able to furnish particulars of the interval which had elapsed between the commencement of the vomiting and the last menstrual period, the interval was eight days in 0.28 per cent., fourteen days in 12.8 per cent., three or four weeks in 36 per cent., six weeks in 10 per cent., eight weeks in 12.3 per cent., twelve to sixteen weeks in 9.2 per cent., and sixteen to twenty weeks in 0.5 per cent. Albeck believes that simple vomiting, intractable vomiting, and vomiting with jaundice and polyneuritis are all conditions of pregnancy toxæmia provoked by noxious substances proceeding from the embryo. He has found, from examination of the thyroid gland twenty-four hours after delivery in 1,581 women, that there is a constant relationship between the size and consistency of the thyroid gland and the intensity of the vomiting—women with a large soft thyroid rarely vomit during pregnancy; those with a small hard thyroid always vomit. Albeck compared also the histological appearances of the thyroid glands in gravid and non-gravid sows, the latter of which did not show any naked-eye enlargement of the gland. In the gravid sows minute examination showed constantly hyperplasia, with mitotic and amitotic nuclear divisions.

63. Sarcoma of the Uterus.

KENDE (*Orvosi Hetilap*, 1919, 32, quoted in *Zentralbl. f. Gynäk.*, September 11th, 1920) records five cases of sarcoma of the uterus, of which two occurred at the age of 27, and three at ages 38 to 51. Three were cases of sarcomatous transformation of myomata. The author emphasizes the importance of submitting to microscopical examination all myomata removed by operation, and of giving prophylactic x-ray treatment. In cases in which x-ray treatment of myomata is not followed by the disappearance of symptoms, the existence of malignant changes in these tumours or in the pelvic organs other than the uterus should be suspected.

PATHOLOGY.**64. Histology of the Typhus Eruption.**

BOMPIANI (*Arch. per le Sci. med.*, vol. 43, Fasc. 3-4, 1920), during an epidemic of typhus occurring in Rome in the summer of 1918 among the prisoners of war and the civilian population, made a histological study of the typhus eruption along the lines taken by Fraenkel. The results were as follows: Rose spots removed on the eighth, tenth, and fifteenth days of the disease showed the characteristic changes described by Fraenkel; they consisted of an accumulation of cells, of various dimensions and of a round or irregularly polygonal form, surrounding a vessel. These lesions were found most frequently in the reticular layer of the dermis, or at the junction of the dermis and subcutaneous tissue. In addition to the typical nodules described by Fraenkel large areas of diffuse infiltration (usually connected with a vessel) were found during the eruption period. At an advanced stage of the disease (twenty-second to twenty-seventh day) lymphoid nodules and fibrous nodules were found.

65. Peripheral Vasomotor and Pulmonary Reactions.

AZZI (*Lo Sperimentale*, Fasc. i-iii, 1920), as the result of observations on thirteen individuals, found that with the production of a peripheral vaso-constriction, as registered by Mosso's plethysmograph on the forearm, a diminution of the temperature of the expired air took place. These observations furnished confirmation of Galeotti's hypothesis that variations in the temperature of the expired air depend on vasomotor changes. It was possible to observe the extreme sensibility of the vasomotor state of the respiratory organs to stimuli of various kinds, including emotion.

66. Tuberculosis of the Female Genitals.

ACCORDING TO DRIESSEN (*Nederl. Tijdschr. v. Geneesk.*, October 23rd, 1920) 10 per cent. of all women with phthisis suffer from tuberculosis of the genitals. Infection may occur in one of three ways: (1) Ascending, by infection from without—for example, by tuberculous semen or dirty instruments; (2) descending, from the peritoneum or intestine; (3) hæmatogenous or lymphogenous. The Fallopian tube is pre-eminently the seat of tuberculous infection. Among 52 cases of genital tuberculosis Driessen found the vulva affected in one case, the vaginal portion of the cervix in one, the endometrium in 5 cases, and the Fallopian tubes in 45, or 86.7 per cent. Tuberculosis of the ovaries is extremely rare, being even less frequent than tuberculosis of the uterus; this has been attributed to the protection afforded by the tunica albuginea investing the ovary. In Driessen's opinion the monthly engorgement of the uterus and ovary plays an important part in their lesser susceptibility to infection, it being well known that during pregnancy (when this factor is excluded) tuberculosis is specially apt to develop.

67. Bacteriology of Influenza in 1918-20.

SINDONI (*La Pediatria*, September 15th, 1920), as the result of investigations in a large number of cases, came to the following conclusions: (1) Pfeiffer's bacillus gives rise to the formation of specific agglutinins in the blood of individuals who are actually suffering from the disease or have recently had it. (2) The agglutinin content of the blood appears on the fourth or fifth day of disease, increases during convalescence, and diminishes when the patient is cured. (3) The amboceptor behaves in a different way, as it is found most easily during the disease, is most difficult to find in convalescence, and disappears on recovery. (4) Pfeiffer's bacillus is almost constant in the nasopharyngeal mucus of influenza patients, and can be found both in smears and cultures. The organism was not found in healthy persons or in other respiratory diseases, nor was it detected in the small epidemics of influenza which occurred in previous years, especially in infants at the Palermo Pediatric Institute. Sindoni, however, does not consider that Pfeiffer's bacillus is the cause of influenza any more than that "X 19" is the cause of typhus.

68. Hypertension in Chronic Nephritis and Arterio-sclerosis.

CARNOT and RATHERY (*Paris méd.*, September 25th, 1920), in addition to experimental evidence, bring forward the following clinical proofs of the necessity of a high blood pressure for maintaining the circulation and diuresis whenever the peripheral or renal resistance is increased. In the first place, arterial hypertension is necessitated by the exaggeration of the renal and peripheral resistance. This increased resistance is due partly to induration, rigidity, and perhaps a certain spasm of the vessels, and partly to increased viscosity of the blood. Secondly, if at a given moment, either spontaneously or as the result of treatment, the hypertension declines, while the resistance remains the same, the circulation and diuresis both fail. Thirdly, the production of hypertension by therapeutic measures—for example, digitalis—re-establishes diuresis.

69. Weiss's Reaction in Typhoid Fever.

WIGGELENDAM (*Nederl. Tijdschr. v. Geneesk.*, October 30th, 1920) regards Weiss's urochromogen reaction as of great value in the diagnosis of typhoid fever owing to its early appearance and simplicity. A specimen of the urine, filtered if necessary, is mixed with two to three parts of water and poured into two test tubes. Two or three drops of a 1 in 1,000 solution of potassium permanganate are then added to one test tube, and if the reaction is positive the urine assumes a bright canary yellow colour, in striking contrast with the urine in the other test tube. The reaction is not specific to typhoid fever, but may occur in advanced pulmonary tuberculosis and scarlet fever. This does not, however, detract from the diagnostic value of the reaction, as these diseases are not liable to be confounded with typhoid fever.

70. *Toxoplasma pyrogenes* Castellani in the Sudan.

CHALMERS and KAMAR (*Journ. Trop. Med. and Hygiene*, February 16th, 1920) have found in a splenic film, made *post mortem*, the bodies (*Toxoplasma pyrogenes* Castellani) which Castellani, working in Ceylon, described in 1915. The patient died of a pyrexial disorder prevalent in an isolated port in the Sennar province of the Sudan.

EPITOME OF CURRENT MEDICAL LITERATURE.

MEDICINE.

71. Chronic Cyanosis.

ZAGARI (*Rif. Med.*, August 7th, 1920) reports two cases of cyanosis of the extremities unassociated with cardiac, renal, or nervous disease. The first was that of a man aged 20 who suffered from paraesthesia and analgesia of the feet and hands, which were oedematous, and became violet after immersion in cold water or exposure to cold, pallid when raised. His general condition was good; there was no cardiac or respiratory disease. The blood pressure varied from 126 to 140 mm. Hg. There was no evidence of nervous disease and no sign of acromegaly. The second patient was a man aged 44. For six months he had noticed uneasy sensations in the hands, made worse by exposure to cold; four months later similar feelings affected the face and lower extremities, and the hands became a dusky violet and increased in size. There was no headache, but a few hard painful nodules appeared on the scalp. There was some degree of sexual impotence. The blood pressure was rather low and the pulse slow (50 to 54). The sella turcica did not appear enlarged; the Wassermann reaction was negative. The face was peculiarly fixed, giving a mask-like appearance; the hands were cold. The bones of the hands were slightly enlarged and thickened. The skin was usually dry, but there were occasional attacks of sweating. In neither case was there any sign of congenital, cardiac, or capillary disease, nor of syringomyelia, hysteria, or myxoedema. In the second case certain points suggested a connexion with acromegaly. Probably both cases were due to vasomotor deficiency. There was no destruction of tissue such as occurs in Raynaud's disease. The author refers to similar cases described by Cassirer and assumed by him to be due to some central vasomotor neurosis associated with endocrinic changes.

72. Digitalis and Ouabain.

VAQUEZ (*Rif. Med.*, July 31st, 1920) says that digitalis is a "diastolic drug," and acts chiefly by altering the rhythm of the heart and disturbing the intracardiac conductivity; it increases the myocardial excitability, but has little or no influence directly on cardiac tone. In his view the particular nature of the valvular lesion to be treated—aortic or mitral—is not of much consequence; the chief point to be considered is irregularity of rhythm. It is in cases of this condition that digitalis is specially useful, but it must be given in adequate doses; small doses are useless, as the effect we wish to produce is a kind of heart-block. There are cases, however, where digitalis given in full doses does no good, and in some of these strophanthin has been found particularly efficacious. Strophanthin, unlike digitalis, is a heart tonic, but it is rather an uncertain drug; the author has been using ouabain, a glucoside with properties akin to those of strophanthin, and this has given excellent results where digitalis has failed. It is especially useful in acute dilatation of the heart. The author gives it intravenously in $\frac{1}{4}$ mg. doses; after ouabain has been administered and produced its effect, digitalis will often prove efficacious to continue with.

73. Arsenical Paralysis due to Neo-salvarsan.

GOVAERTS (*Le Scalpel*, October 9th, 1920) records the case of a man, aged 23, who, after nine injections of neo-salvarsan, developed characteristic arsenical exfoliative dermatitis. Two months later, when the lesions were cured, another injection of neo-salvarsan was given, and a more violent and prolonged attack of arsenical dermatitis supervened, followed by paralysis of the extensor muscles of all four limbs. The paralysis persisted for about ten days and then progressively diminished, so that when the patient was discharged from hospital his gait was normal, though the knee-jerks and ankle-jerks were still absent.

74. Treatment of Whooping-cough.

LEDERER (*Wien. Klin. Woch.*, November 25th, 1920) has treated twenty-five cases of pertussis by painting the throat every two days with a 2 per cent. watery solution of silver nitrate, as recommended by Ochsensins. In the great majority of cases good results were obtained. He found that the paroxysmal stage was considerably shortened;

the paroxysms at night were diminished, and long-standing attacks were rapidly cured. He attributes the success of the treatment not to a specific bactericidal action, as Ochsensins maintains, but to suggestion. The method should be reserved for older children without a neuropathic disposition, in whom the attacks have lasted a considerable time.

75. Heliotherapy in Secondary Syphilis.

RASCH (*Ugeskrift for Læger*, November 25th, 1920) notes that while heliotherapy is a generally recognized and valued remedy in tuberculosis, its possibilities have hardly been discussed, far less tested, in syphilis. Apart from publications dealing with syphilitic leucoderma and its relation to sunlight, little or nothing has been written about the action of sunlight on the *Spirochaeta pallida* and its manifestations. As an incentive to experimental investigations, the author records a case in which a secondary eruption was universal except on those parts of the body which had been exposed to the sun. The patient was a girl of 19, whose disease had been neglected. As the illustrations published by the author show, the eruption ceased abruptly at a line corresponding with the upper limits of her low-cut bodice. It appeared that the marked pigmentation of the upper part of her chest and back was due to her having had to wheel an invalid about in the sun daily throughout the previous summer.

76. Vaccine Treatment of Empyema.

DELBEZ (*Bull. et mèm. Soc. de Chir.*, December 14th, 1920) records the case of a child, aged 2, with a staphylococcal empyema following pneumonia, in whom the effusion filled almost the whole of the left side of the thorax. Within sixty days, however, after eight injections of antistaphylococcal vaccine, all the effusion had subsided without operation and the patient had gained more than a kilogram in weight. Four months later it was impossible to tell by percussion or auscultation on which side the empyema had been situated, and on x-ray examination the left side of the thorax presented a normal appearance.

77. Bronchiolitis due to Irritant Gas.

DE CONCILIS (*Rif. Med.*, September 4th, 1920), describing the acute symptoms which follow the inhalation of irritating gases, says they may be divided into three stages. The first stage is characterized by severe reflex phenomena—for example, sense of suffocation or of constriction of the fauces, asthma, obstinate cough, and in some cases death by syncope. The dyspnoea is mainly expiratory and irregular, with frequent exacerbations; cyanosis, subcutaneous emphysema, dilatation of the right side of the heart, and slowing of the pulse are often present. The obstruction to the flow of blood in the veins of the head and neck may cause slight exophthalmos and increase in the circumference of the neck. The râles present are sonorous and the percussion note is resonant. Expectoration is frothy and blood-stained. The temperature is usually normal. This first stage lasts from one to two weeks. The second period is marked by a rather sudden cessation of the symptoms, due to reduction in the swelling of the mucous membrane. In the third period the symptoms of asphyxia reappear in consequence of cicatrization of the small bronchioles. Some of these cases were wrongly diagnosed as miliary tuberculosis. Pathologically the lesion produced by gas is a necrosis with consecutive connective tissue proliferation in the bronchioles.

78. Arterio-sclerosis and Dementia Praecox.

LIE (*Norsk. Mag. for Lægervidenskaben*, November, 1920) has attempted by the following investigations to answer the question: does arterio-sclerosis play a part in the genesis of mental disease, notably dementia praecox? At Dikemark Asylum 112 cases of dementia praecox (70 males, 42 females), all under the age of 35, were admitted within a period of three years. Six of these cases were rejected for investigation because the diagnoses were in doubt. Among the remaining 106 there were 41, or 38.7 per cent. (37 males, 4 females), whose arteries showed more or less definite thickening. The difference in the frequency of arterio-sclerosis in males and females was striking, and it was noted that practically all the males with arterio-sclerosis were manual labourers. Alcohol

and syphilis were seldom noted in the histories, but all the males were more or less addicted to tobacco, most having begun to use it under the age of 15; 2 had begun even before the age of 6. The author commits himself to no definite correlation of arterio-sclerosis with the onset of dementia praecox, but he suggests that the frequency of arterio-sclerosis among the male subjects of dementia praecox deserves further study.

79. False Perforation in Paratyphoid B Fever.

OLLIVIER (*Journ. de Méd. et de Chir. Prat.*, September 25th, 1920) reports an example of the occurrence in paratyphoid B fever of a syndrome similar to that met with in typhoid and called by Roehard "false perforation." In such cases laparotomy (which is followed by an immediate disappearance of the symptoms) shows only a few adhesions, slight redness and congestion, a dilated colon full of faeces, or no lesions at all as in Ollivier's case. A painful reflex of mesenteric origin has been suggested as the explanation of the condition.

80. Cerebral Diplegia and Little's Disease.

ACCORDING to VAGLIO (*La Pediatria*, September 15th, 1920), who records eighteen illustrative cases, between spastic hemiplegia, double hemiplegia and cerebral diplegia, there is a difference of degree only. All three constantly show a uniformity of symptoms, a variability of lesions both as regards their character and extent, and a plurality of causes. The prevalence of contractures over paralysis, or vice versa, is not, in Vaglio's opinion, sufficient to produce fundamental differences.

SURGERY.

81. Acute Primary Perichondritis of the Larynx.

ACCORDING to LAVIELLE (*Rev. de laryng., d'otol., et de rhinol.*, October 30th, 1920), two forms of this condition may be described—namely, a circumscribed form and a diffuse form. The circumscribed form, of which an example is recorded in a woman, aged 35, successfully treated by operation, is characterized by pain and cough, without any difficulty of breathing. The neck is increased in size, movement of the head is difficult, and examination of the region is very painful. Laryngoscopy shows redness and swelling of the vocal cords. There is considerable general disturbance. The prognosis is good, recovery taking place with a loss of a portion of the thyroid cartilage. In the diffuse form pain is the principal symptom, swallowing is difficult, and there is marked embarrassment of respiration. Laryngoscopy, which is difficult to perform, shows a diffuse redness and more or less pronounced swelling of the arytenoids and vocal cords. Suppuration, contrary to what occurs in the first form, is exceptional. The general condition is very grave, and the prognosis is almost always extremely grave.

82. Subretinal Cysticercosis.

ACCORDING to PILLATT (*Wien. Klin. Woch.*, October 14th, 1920), who records a case of successful removal in a man aged 29, subretinal cysticercosis was a very rare condition before the war. Thus in Sattler's eye clinic at Leipzig only two examples occurred among 90,000 cases, and in Herrenschwand's eye clinic at Innsbruck in the sixteen years prior to the war not a single case occurred. Nor were any examples met with by Hirschberg among 65,000 cases from 1895 to 1902, nor by Silex in the Berlin Polyclinic during the ten years preceding the war. Since 1900 only two instances have been seen in Vienna among 250,000 eye cases. The greater frequency of subretinal cysticercosis since the war is due to bad sanitary conditions, and the inability to cook meat long enough during a war of movement. The cases have occurred exclusively in soldiers. Two cases were reported by Carsten in 1916 and 1917, two by Herrenschwand in the Innsbruck clinic, four by Uthoff in the Breslau clinic, and one by Schick in Halle.

83. The Importance of Wassermann's Reaction in Institutions for Scrofula.

HERTZ (*Ugeskrift for Laeger*, October 21st, 1920), who has carried out systematic Wassermann tests at the coast hospital at Retsnaes in Denmark for the past ten years, finds this test of great service. It was positive in 2.5 per cent. of his 1,610 cases, and it enabled him to institute rapidly curative specific treatment in many cases which

for years had received no benefit from antituberculous treatment in various hospitals and sanatoriums. Among the cases of arthritis syphilis of the knee-joint predominated, and among the ocular diseases dacryocystitis, sometimes with ulceration, was so common that the author has come to suspect syphilis in every such case. But among several hundred cases of spina ventosa he has found syphilis only in two, although Calot and Menard maintain that syphilis is responsible for 50 per cent. of all cases of this condition.

84. Strychnine in Post-operative Atony of the Stomach.

DISCUSSING the mechanism and treatment of post-operative dilatation of the stomach, HANSEN (*Ugeskrift for Laeger*, November 18th, 1920) recommends the injection of strychnine, which he found remarkably effective in the following case: A man, aged 21, was operated on under ether anaesthesia for ulcer of the pylorus; a gastro-enterostomy was performed. Eight days later vomiting set in, and was so refractory to treatment, which included repeated aspiration of the contents of the stomach and injections of eserine, that the abdomen was again opened. But no kink or other cause for the continued vomiting could be found, and the abdomen was again closed. The vomiting and other signs of gastric atony persisted in spite of large quantities of bile-stained fluid being withdrawn three times a day through the stomach tube. When this condition had lasted eighteen days after the second operation, and there was no sign of improvement, 1 mg. of strychnine was injected with almost immediate effect. The vomiting ceased, the diuresis increased, and recovery followed.

85. A New Anaesthetic.

BARDE (*Bull. Soc. de Thér.*, November 10th, 1920) describes a new anaesthetic named diethyl-diallyl-barbiturate of diethylamine, which is prepared by a combination of diethylbarbituric acid (or veronal) and diallylbarbituric acid with diethylamine. Given intravenously it produces a narcosis varying in duration from twenty-four to forty-eight or even sixty hours. It is regarded as suitable for operations in which complete muscular relaxation is not required. The claim is made that it forms a valuable adjuvant to general anaesthesia, as it does away with the stage of excitement and renders only a very small quantity of anaesthetic necessary.

86. Removal of Astragalus in Paralytic Feet.

THE end-results in 217 cases of infantile paralysis in which the astragalus was removed for a paralytic condition of the foot, resulting in lateral instability and various other deformities, are given by SEVER (*Journ. Amer. Med. Assoc.*, October 30th, 1920). Whitman's operation was performed on 217 feet in these cases by eight different surgeons; the feet varied from those completely paralysed to those in which only one muscle was weak or gone. In many cases the operation failed to restore either symmetry or stability. As a result of this analysis Sever feels that astragalotomy is not an operation to be advised for any foot showing lateral instability as a result of the paralysis of one muscle-group alone. The lateral instability at the ankle may be averted, but more subsequent deformity may develop. Astragalotomy is as good an operation as any in feet which are flail, or those which have only one muscle group left. In the presence of toe flexors, varus is likely to develop later and lead to a bad weight-bearing position. The best results are found in feet in which there was good muscle power before operation, and when after operation there resulted good motion between the tibia and os calcis, and good weight-bearing positions of the foot. The operation will not cure a limp, or even improve one as a rule; it should be performed on older children in selected cases.

87. Dupuytren's Contraction.

ALI KROGIC (*Finska Läkaresällskapets Handlingar*, September and October, 1920) has investigated the 22 cases of Dupuytren's contraction observed at his hospital since 1838. In 12 the disease was bilateral, and of the unilateral cases 7 were right-handed. All the same, the author can find little or no connexion between heavy manual labour and the development of this disease, and among his patients were officials, business men, and a soldier. Ten per cent. of the professors of Helsingfors had suffered from this condition, which in 4 cases appeared to be hereditary. Thus, in one family, 16 cases had occurred in four generations, and it appeared from the genealogical table that this hereditary tendency could be transmitted through

healthy women. Of the 22 cases, 18 were males, and the disease developed in more than half the cases before the 40th year. The author's histological examinations in 13 cases have convinced him that the disease is primarily due to the conversion of embryonic islands of muscle cells into fibrous tissue. The histological examination of the palmar aponeurosis of newborn infants showed that, among the bundles of fibrous tissue small islands of striated muscle undergoing conversion into fibrous tissue could be found. On the other hand, the author could never find any sign of inflammation, such as a small-celled infiltration. He does not, however, deny the possibility of trauma provoking this condition, but he considers it primarily as a developmental disease due to disorders of growth in the superficial palmar muscles. Much of his paper is concerned with the palmar muscles of various mammals.

88. Famine Osteomalacia.

ACCORDING to CRAMER and S. HIFF (*Rec. med. Suisse rom.*, November, 1920), who report a case in a native of Geneva who had spent her last two years in Russia, the onset of famine osteomalacia is almost always insidious and its course at first regularly progressive. Three forms may be described: (1) Abortive attacks, which are rare. (2) Moderate attacks, in which the loss of power is not complete. (3) Severe attacks, in which the patients are bedridden and their immobility is complete. In the moderate cases there are two principal symptoms—namely, costal pain on pressure on the chest (most marked over the seventh and eighth ribs) and a peculiar cautious and waddling gait, both these symptoms being due to the softening of the skeleton. In the severe form these symptoms are more pronounced. Respiratory movements are sufficient to cause pain in the thorax, walking is impossible, and the sternum is soft and elastic. Pressure is painful on all the bones except the skull. Bony deformities appear, especially kyphosis in the dorsal and lumbar region, and fractures, complete or incomplete, occur, usually both in the extremities and the ribs. The renal functions are not affected. Famine osteomalacia is distinguished from ordinary osteomalacia by its rapid progress and the more uniform affection of the skeleton, the pelvis being most markedly affected in ordinary osteomalacia. Lastly, famine osteomalacia is rapidly improved by calcium and phosphorus medication, which is useless in ordinary osteomalacia. Most writers are agreed in attributing famine osteomalacia to a pluri-glandular insufficiency due to inadequate nourishment.

OBSTETRICS AND GYNAECOLOGY.

89. Cervico-vaginal Fistulae.

BECKER (*Zentralbl. f. Gynäk.*, September 25th, 1920) records two cases of cervico-vaginal fistulae tunnelling the posterior lip of the cervix. The first case was that of a woman of 19, to whom, one week after a missed period, an abortionist had given injections through a gum-elastic catheter, previously dipped in an antiseptic solution. This procedure was repeated almost daily for some weeks; eventually, when the pregnancy had continued to the beginning of the fourth month, a severe haemorrhage ensued. The external os was found to admit one finger; in the posterior portion of the cervix was a perforation admitting two fingers and leading into the cervical canal. The foetus was 18 cm. long; an arm had prolapsed through the fistula and lay in the vagina; the fistula and the cervical canal were occupied by the remaining parts. The embryo having been removed, convalescence was uneventful, but the fistula persisted. The second case also was due to criminal abortion, attained in this case after fewer injections and in the second month of pregnancy. In both cases the vaginal fornices were otherwise uninjured. According to Neugebauer, who has recorded thirteen cases falling in the first and four in the second group, cervico-vaginal fistula of the posterior lip of the cervix may be due to (1) obstetric trauma, (2) criminal abortion, or (3) pathological conditions such as tuberculosis, diphtheria, syphilis, or carcinoma.

90. GRASMANN (*Deut. med. Woch.*, June 24th, 1920) records a case of cervico-vaginal fistula which occurred in a primipara aged 22, who aborted at the fourth month. He regards the complication as being due to exaggerated uterine ante-flexion, and to rigidity of a somewhat hypoplastic cervix and os externum.

91. Intrauterine Therapy for Uterine Infection.

VIGNES (*Gynec. et Obstét.*, 1920, ii, 3) remarks that intra-uterine treatment, widely recommended at the close of last century for puerperal infection, has been renounced by many obstetricians—partly as a result of extended clinical obstetrical experience, and partly because war surgery has shown that wounds infected by streptococci are particularly resistant to local treatment, of which the only efficacious method is early excision. Curettage does not necessarily remove all infected foci; it is usually followed by a rise of temperature and not infrequently by a serious and prolonged aggravation of the symptoms. By curettage the lymphocytic barrier is broken down; parametritis and thrombo-phlebitis are relatively more frequent after curettage. Digital scraping, according to de Lee, Couvelaire, and Vignes, is equally as objectionable as instrumental curettage. Vignes, from a comparison of cases of puerperal infection in which intrauterine treatment has and has not been used, concludes that the gravity and mortality of the malady are almost doubled by intervention. In cases of uterine infection following labour at term—cases of partial placental retention excepted—it is dangerous and useless, he thinks, to employ intrauterine treatment after the first week. Intra-uterine applications—for example, of alcohol or iodoform—are unjustifiable; these cannot kill the micro-organisms without killing the tissue cells, and some of them kill the tissue cells without killing the micro-organisms. Douching is the least objectionable form of intrauterine therapy, but may be followed by untoward primary or remote effects; it is usually without effect on the course of the infection, but may be justifiable—provided that it be not performed more than once—in cases of retention of loose fragments of the membranes or of clots.

92. Abdominal Hysterectomy for Puerperal Infections.

ACCORDING to LE JUMENTEL (*L'Année méd. de Caen*, March, 1920) hysterectomy may sometimes be practised with benefit in cases of puerperal infection; it may lead to good results even in cases where there is a blood infection. Four cases are recorded, with three cures. Two of the successful cases were of placental retention, operation being performed on the second and fifteenth days respectively.

93. Tuberculosis of the Cervix.

VERBELET and DARAB-NIZ (*Journal. de Méd. de Bordeaux*, September 25th, 1920) record the case of an unmarried woman, aged 25, who had never menstruated, but for about a year had been becoming progressively thinner and had had a pale discharge. The cervix was small, and the os could not be felt nor seen; on the right lip there was a soft polypus 5 or 6 mm. long, and almost insensitive. The cervix also showed the presence of multiple small clean-cut ulcerations. The polypus was removed, and the region of its insertion as well as the ulcers cauterized. Microscopically the polypus contained numerous glandular tubules between which tubercles could be seen.

94. An Unusual Case of Hydatidiform Mole.

VOILET (*Gynec. et Obstét.*, 1920, ii, 1, and *L'Année méd.*, 1920) records the case of a woman four and a half months pregnant, who had had haemorrhage for two months and a half. The size of the uterus was consistent with the duration of the pregnancy; through the dilated external os a soft mass could be palpated within the cervical canal. Cure was effected by vaginal Caesarean section. The uterus was found to contain no foetal parts; the whole of the mass extracted consisted of placental tissue showing long-standing haemorrhages and infarcts, and here and there a few vesicles, of which some were of spherical shape and about half the diameter of a lentil, and others were of the shape and size of a date stone.

95. Dystocia Due to Carcinoma of the Foetal Kidney.

PORTER and CARTER (*Liver. Journ. of Diseases of Children*, October, 1920) record the case of a 6-para, aged 35, in whom at term the head, shoulders, and arms of the child were spontaneously delivered, but the remainder of the body could not be brought down. The patient being anaesthetized, an incision was made into the abdomen of the dead foetus; a sufficient amount of friable tumour tissue was removed to permit the remaining parts to be borne. The tumour, which was almost twice the size of the foetal head, was proved microscopically to be a rounded sarcoma of the kidney. The course of the pregnancy had presented no unusual features.

96. Influence of Forceps on the Subsequent Physical and Mental Development of the Child.

ENGELKENS (*Nederl. Tijdschr. v. Geneesk.*, October 16th, 1920) made an inquiry into the subsequent history of 448 children who had been delivered by forceps in the Amsterdam and Groningen Obstetrical Clinics between 1900 and 1914. Information was obtained concerning 232 only. In 105 low forceps, and in 39 high forceps, had been used; in 82 Lange's method, and in 6 Scanzoni's method had been employed. The result of the inquiry was that the forceps was thought to have been responsible for one case of epilepsy and possibly for one of imbecility among the 232 cases. It was remarkable that no instance of spastic diplegia was found, although Little and many after him have attributed the condition entirely to an abnormal birth. Engelkens concludes that the influence of forceps extraction on the mental and physical functions of the child is exceedingly slight.

97. Early Recognition of Uterine Cancer.

JACOBS (*Gynec. et Obstet.*, 1920, i. 6) expressed to the Belgian Gynaecological and Obstetrical Society the opinion that the most hopeful means of diminishing the mortality from uterine cancer lies in the dissemination among the laity, as well as among doctors, chemists, and midwives, of a greater knowledge of its earliest symptoms. Among 98 patients suffering from this disease he found that those who deferred the taking of medical advice for from twelve to twenty-four months numbered 37; 5 patients first consulted the doctor nine to eleven months after the appearance of the first symptoms; 15 eight months after; 4 six months after; 4 four months after; 14 three months after; 7 two months after; and 9 one month after. Nine only sought advice during the first month; 3 consulted the doctor at once. The cause of the procrastination was in 72 cases carelessness and ignorance; in 8 cases fear; in 6 cases poverty; and in 3 cases shame. In 26 cases advice was first sought from a specialist, in 31 from the family doctor, in 6 from a midwife, in 14 from a chemist, in 2 from totally ignorant persons. In 19 cases the seeking of advice was not followed by vaginal examination. Of these 98 cases, 72 when first seen by the author had reached the inoperable stage.

PATHOLOGY.**98. A New Serum Reaction in Syphilis.**

GATÉ and PAPACOSTAS (*C. R. Soc. Biologie*, November 20th, 1920), accidentally discovered a new and simple method for examining the serum in the diagnosis of syphilis. They had been accustomed to pool their positively reacting serums, the mixture serving to control the fixative power of the antigens, and also to pool the negatively reacting serums in order to fix the complement-absorbing unit in the Wassermann reaction. These serums were preserved as usual in an ice-chest, but owing to an explosion occurring in the laboratory they were forced temporarily to use some other means of keeping the serums uncontaminated. For this purpose they added formalin, but were astonished to find on the following day that the mixture of serums reacting positively in the Wassermann test had coagulated to such an extent that the tube could be turned upside down without disturbing the clot. The mixture of negative serums, on the other hand, remained perfectly fluid. This observation led them to study the phenomena more closely, and on a larger scale. The test as now evolved consists merely in placing with a pipette 1 c.cm. of clear serum at the bottom of a test tube, adding two drops of commercial formalin, shaking to obtain a good mixture, and leaving the tubes stoppered with cotton-wool at the room temperature for twenty-four to thirty hours. The reading of the reaction is easy: in positive reactions the mixture becomes more or less solid, clear, and jelly-like; in negative reactions it remains perfectly fluid. In this way they have tested over 400 serums, and compared the results with those obtained in the Wassermann reaction. Mixtures of positive Wassermann serums always give positive formalin reactions, and mixtures of negative Wassermann serums always give negative formalin reactions. In separate cases the results of the Wassermann reaction and this formalin reaction accord in 85 per cent. of instances. They state that where the two reactions disagreed they were unable to discover which was the more accurate, as the true diagnosis in these cases was unknown. However, in certain cases, such as early syphilis, clinically certain, where the Wassermann reaction failed, the formalin reaction gave positive results.

Preliminary inactivation of the serum is unnecessary, nor does it modify the reaction in any way to incubate the mixtures.

99. Acquired Immunity in Influenza.

DOPTER (*Paris méd.*, October 23rd, 1920) has collected a large quantity of epidemiological and experimental evidence showing definitely the acquisition of immunity after a first attack of influenza. This applies only to influenza itself, and not to its complications, which, during an epidemic, may be contagious in themselves without any influenza substratum. Although immunity does exist, it is not absolute, as Burrige and Cummins observed second attacks in 20 to 23 per cent. of their cases. The duration of the immunity, according to observations made by Malone in India, is at least nine months, and possibly longer.

100. Parasitic Amoeba in the Tonsils.

TIBALDI (*Annal d'Igiene*, October, 1920) draws attention to a new species of amoeba found by him in the tonsils and called *Entamoeba macrohyalina*. Two kinds of entamoebae may be found in the tonsil: (1) *Entamoeba buccalis* or *gingivalis*, commonly found in the mouth and occasionally in the tonsil; (2) *Entamoeba macrohyalina*, which is much more rarely detected and prefers the crypts of the tonsils. Owing to paucity of material, the author is unable to express an opinion as to the pathological importance of these entamoebae. Both amoebae are fully described and coloured reproductions of their microscopic appearances are given.

101. Pathology of Congenital Laryngeal Stridor.

WERNSTEDT (*Hygiea*, October 16th, 1920) has examined *post mortem* two cases of laryngeal stridor in infants dying of intercurrent diseases. The first case was that of a female infant who had suffered from laryngeal stridor since birth. She died of whooping cough when 9 months old. A close comparison of her larynx with the corresponding organs of eleven other infants showed practically no deviation from the normal, apart from a negligible narrowing of the larynx in the sagittal plane. The second case was that of a female infant, who had suffered from laryngeal stridor since birth, and who died of bronchopneumonia. The larynx in this case corresponded in every respect with the larynges of six "control" infants of the same age, with the important exception that the aditus laryngis formed an abnormally narrow, slit-like opening owing to the exceptionally close proximity to each other of its component parts. The author suggests that these cases may be taken as types of two distinct classes: In the one the stridor is a functional disturbance—a disturbance of co-ordination; in the other definite anatomical anomalies, such as stenosis of the aditus laryngis, give rise to the stridor.

102. Rapid Preparation of Polychrome Methylene Blue Stain.

THIBAUT (*Journ. Amer. Med. Assoc.*, November 20th, 1920) describes the preparation of polychrome methylene blue (used for staining fresh tissues) by a method which does not necessitate waiting for six days, or more, till the stain ripens. One part of methylene blue and one part of potassium carbonate to 100 parts of water are boiled in a flask for fifteen minutes and allowed to cool; after filtering, the stain may be used at once. The stain keeps well; its efficiency may be increased by the use of a mounting fluid containing resorcin (75 parts of water, 8 of sodium chloride, 2 of resorcin, and 25 of glycerin).

103. The Presence of Spirochaetes in Lymphatic Glands.

FRICHWALD (*Wien. klin. Woch.*, November 11th, 1920) carried out 89 punctures of the lymph glands in 83 syphilitic patients to determine the presence of the *Spirochaeta pallida*, with the following results: Of 24 patients in the primary stage, 20 showed spirochaetes in the regional lymphatic glands. Of 18 patients at the beginning of the secondary stage, only 7 showed spirochaetes in the puncture fluid. Of 27 cases in the late secondary stage, 20 were negative; 4 cases in the tertiary stage were also negative. Of 14 cases in the latent stage, 3 were positive and 11 negative. It is thus obvious that in the early stage of syphilis the *Spirochaeta pallida* is very frequently present in the regional lymph glands, and even in the late secondary stage it is often found, though with diminished frequency. The duration of the disease in such late secondary cases was from four months to two years. In the latent stage spirochaetes were found as late as the third year of the disease.

EPITOME OF CURRENT MEDICAL LITERATURE.

MEDICINE.

104. Lumbar Puncture and Meningitis.

REGINALD WEBSTER (*Med. Journ. of Australia*, November 27th, 1920) records a series of experimental investigations into the part played by lumbar puncture in precipitating meningitis in animals rendered artificially septicæmic, and makes a plea for the conservative use of diagnostic lumbar puncture. As a result of his researches, he feels warranted in urging that the lumbar puncture needle should not be employed, except in the presence of definite clinical signs of meningitis, and in deprecating its use as a possible royal road to the diagnosis of an obscure condition. Lumbar puncture in the presence of a septicæmia may operate in two ways to promote infection of the meninges: (1) by impairing the integrity of the choroid plexus and meningeal lymphatics; (2) by extravasation of blood, which itself may be infective, within the cerebro-spinal space. Hæmorrhage within the dura mater, apart from infectivity, aggravates the effect of withdrawal of cerebro-spinal fluid, for it is the equivalent of the "bland irritant" introduced into the spinal canal in the work of the different experimenters quoted. It is not suggested that spinal puncture, in the presence of a septicæmia, invariably leads to meningitis; but evidence is adduced to show that when conditions as regards severity of the septicæmia and pathogenicity of the causal organism for the meninges are favourable, there is a definite risk attached to the operation of lumbar puncture. As regards pneumonia in children, the fact that the clinician maintains a constant look-out for complications such as meningitis and arthritis, is a tacit recognition of the hæmic nature of the pneumococcus infection; unless the bacteriological condition of the blood has been carefully investigated, a measure possible as a routine only in hospital practice, lumbar puncture should not be lightly undertaken. As long as the results of pneumococcal meningitis remain as disappointing as they are at present, the withdrawal of a cloudy fluid does nothing more than establish the diagnosis; there would be no objection whatever to the puncture if a purulent fluid could always be foretold, but how rarely does it materialize even when confidently anticipated? Once the decision to perform lumbar puncture has been reached, it would seem wise, unless the fluid is definitely turbid, to take off just sufficient for laboratory examination.

105. Pathogeny and Treatment of Diabetes Insipidus.

NASSO (*La Pediatria*, September 1st, 1920) records the case of a girl of 8 years who developed, at 4 years, symptoms of diabetes insipidus, the average amount of water swallowed being from 11 to 14 litres and the average amount of urine passed from 12 to 15 litres in the twenty-four hours. Intramuscular injection of pituitary extract was followed by rapid improvement, the amount of urine falling to 4 to 5 litres a day and the amount of water taken to 3 to 4 litres. Nasso concludes that the pathogenesis of diabetes insipidus is connected with pituitary insufficiency, and that the treatment should be based on a proper use of pituitary extract.

106. Purpura in Cerebro-spinal Meningitis.

ACCORDING TO BONNAMOUR (*Lyon Méd.*, December 15th, 1920), who records an illustrative case, contrary to what occurred in the United States during the epidemics of 1805-1811, in Ireland in 1866-67, and in Germany from 1886-87, purpura until recently has been very rarely observed in cerebro-spinal meningitis in France, where it was noticed for the first time by Rist and Paris in 1902. Since then, and particularly since 1909, its frequency has decidedly increased, so that Netter found it in 13 per cent. of the cases of cerebro-spinal meningitis in 1913 and in 20 per cent. in 1917. It was first observed at Lyons during the war, especially among the soldiers, while it remained rare among the civilian population. Purpura may appear at any stage of cerebro-spinal meningitis. It most frequently appears between the second and fifth day of the disease, but it may precede the meningitis, or, as in Bonnamour's cases, be almost the only symptom of cerebro-spinal meningitis which was not discovered till the autopsy. Lastly, though more rarely, purpura may occur by itself without any meningeal localization in association with septicæmic phenomena such as arthritis, fever, and

general disturbances. Lumbar puncture in such cases always shows a clear, sterile fluid, whereas blood cultures and examination of the petechiae yield meningococci. In a case of severe purpura lumbar puncture should always be performed and a culture made from the serum of the skin lesions, so that, if necessary, intrathecal combined with intravenous or intramuscular sero-therapy may be employed.

107. The Diphtheritic Heart and its Treatment.

AASER (*Lidsskrift for den Norske Lægeforening*, September 15th and October 1st, 1920) has studied the cardiac complications of diphtheria, and compared the mortality of this disease as treated at Ullevaal Hospital, at different periods. He classifies his material in four groups, according to the extent and severity of the disease, and he finds that in the pre-serum days—that is, between 1893 and 1894—the mortality was as high in the second group of cases as it was in the fourth group—that is, the most serious cases treated with serum in the period 1915-1918. But though the increasing dosage of serum undoubtedly reduced the mortality, it did not banish the cardiac complications of diphtheria. Indeed, these would appear to be more frequent, and the author suggests that this fact may be correlated with the presence of 0.5 per cent. of carbolic acid in the serum used in Norway. Though some of it may be deposited as "carbolic acid albumin" and is filtered off, enough may be left to cause serious injury. In addition to prophylactic measures, such as absolute rest, morphine is an invaluable remedy for children as well as adults, reducing as it does restlessness and insomnia. Adrenalin given subcutaneously is remarkably effective in some cases, but useless in others. An ice-bag placed over the heart sometimes has a definitely stimulating effect on the heart and also exerts a restful influence, particularly in children. It is also necessary to keep the organism adequately flushed with fluids.

108. Familial Spastic Paraplegia.

DE STEFANO (*La Pediatria*, October 1st, 1920) gives an account of two families in one of which four members and in the other two were affected by spastic paraplegia. In the five cases which came under the author's observation congenital syphilis was present, and in three there was consanguinity of the parents. From observation of the cerebro-spinal fluid in his cases de Stefano concludes that the condition is due to a direct action of the syphilitic virus on the meninges, followed by more or less extensive degeneration of the nervous system. Familial spastic paraplegia, which was first described Strümpell in 1880, is characterized by the association of the familial character of the disease with spastic paralysis, which is almost constantly accompanied by disturbance of the intelligence and often of speech. It is to be distinguished from the spastic tabes dorsalis of Charcot or spastic contracture of the lower limbs in the adult due to primary sclerosis of the pyramidal tracts.

109. Nitro-benzol Poisoning Treated by Blood Transfusion.

HINDSE-NIELSEN (*Lægekrift for Læger*, September 9th, 1920) considers that the treatment of poisoning with nitro-benzol (mono-nitro-benzol, nitro-benzine, oil of Mirbane, $C_6H_5NO_2$) should include transfusion of blood when the symptoms are severe and a fatal issue seems probable. In this connexion he records the case of a servant girl, aged 19, who took a tablespoonful of nitro-benzol in the afternoon, vomited soon afterwards, and was admitted to hospital the same evening in a state of delirium and unconsciousness. She was extremely cyanosed, the mucous membranes being of a dark-blue colour. There was a bluish froth about her lips, and her breath smelt of oil of bitter almonds. Her stomach was repeatedly washed out, and oxygen was administered, but her condition remained critical. Accordingly, 600 c.cm. of her blood were withdrawn, and an intravenous injection of 1 litre of citrated blood (0.4 per cent. sodium citrate solution) obtained from a nurse was given. During this procedure the colour of the patient's skin changed to a rosy tinge. Ultimately complete recovery was effected without signs of embolism or thrombosis. With reference to blood transfusion, the author emphasizes the advantages of collecting the blood from the donor in ten separate vessels instead of in one large vessel. In the latter case coagulation in part of the

blood is apt to extend to the whole quantity. But when several vessels are used, coagulation in one does not spoil the results for the remainder; in the author's case coagulation did occur in one, but not in the remaining nine vessels.

110. Smoking and Mental Activity.

BAUMBERGER and MARTIN (*Journ. of Industrial Hygiene*, October, 1920) give a first report concerning the industrial efficiency of persons using tobacco in different amounts. The output curves of a small group of Morse code telegraphic operators were examined; the occupation of these workers demanded concentrated attention and delicate neuro-muscular co-ordination. It was found that the heavy smokers of the group showed a higher output rate at the beginning of the day than the light smokers, but that their rate fell off more markedly in the later hours, and that their production for the day was definitely less than that of the light smokers. The heavy smokers showed also less ability than the light smokers to respond to increasing pressure of work in the late hours of the day by handling their full share of the work presented to them. These results are in accord with the suggestion advanced by other investigators, that strenuous mental work is likely to be affected adversely by heavy smoking.

111. Chrysarobin and Psoriasis.

WARD (*British Journ. of Dermatology*, October, 1920) relates the case of a man, aged 38, who had suffered intermittently from psoriasis since he was 17, in whom a fresh outbreak of psoriasis papules developed as the result of using a chrysarobin ointment twice as strong as usual—10 grains instead of 5 grains. The fresh lesions were successfully treated by application of the milder ointment.

112. Malaria caused by Injection of Human Serum.

VAN DIJK (*Nederl. Tijdschr. v. Geneesk.*, September 25th, 1920) records the case of a nursing sister, suffering from a severe attack of influenza, whom he transfused with the blood of another sister convalescent from the disease. Three weeks later the first patient developed a typical attack of tertian malaria. She had never had a previous attack, and there was no malaria in Rotterdam at the time. It then transpired that the donor had suffered from malaria, though her last attack had occurred seven months previously; malarial parasites were found in her blood.

SURGERY.

113. Detachment Fractures following Strain

USLAND (*Medicinsk Revue*, August-October, 1920) discusses the mechanism and treatment of detachment fractures caused by sudden violent exertion. One of his patients, aged 17, tried to kick a football with his right foot, but expended much of the force of the kick on the ground. Violent pain was at once felt in the left inguinal region; he collapsed, and could not stand up again. A skiagram showed a detachment fracture of the small trochanter on the left side. He was kept in bed with the left leg raised and immobilized with sandbags for nearly three weeks. Uneventful recovery followed, and a skiagram showed solid bony union. The author records two cases of detachment fracture of the tuberosity of the tibia, one of which was treated by operation (osteosuture with silver wire and chromic acid catgut), the other with plaster-of-Paris immobilization for six weeks. In both cases complete recovery was effected. Reviewing his own experiences and the literature of the subject, the author notes that, as a rule, the symptoms are slight and medical aid is not sought. The patient continues his exercise, sparing the affected limb when it hurts; in the course of about a year spontaneous recovery is complete. When the symptoms are severe enough to lead to a medical examination, a correct diagnosis and proper treatment soon result in complete recovery. The author points out that in the case of the leg it is better to immobilize the limb with plaster-of-Paris for five to six weeks than to neglect immediate adequate treatment, and merely to impose a general interdiction on all exercise for a couple of years.

114. Pepsin Treatment of Ozaena.

DE LEVIE (*Nederl. Tijdschr. v. Geneesk.*, December 18th, 1920) describes Griessmann's treatment of ozaena, which proves very effective owing to its combination of a chemical with a mechanical factor. A powder containing pepsin is insufflated into the nostrils, which are also irrigated with

a solution containing pepsin. The pepsin exercises a digestive action on the nasal crusts, as has also been found *in vitro*. Crust formation no longer takes place, for the pathological secretion combines with the powder before this can occur, and it is thus very easy to clean out the nose by irrigation. Griessmann states that a few days after the use of the powder the crust formation and foetor considerably diminish. De Levie, who employed the method in fifteen cases of ozaena, fully confirms Griessmann's observations, the results being much more satisfactory than those obtained by any other mode of treatment. He modified the original method by using a weak saline solution for nasal irrigation.

115. Acute Necrosis of the Pancreas.

MOCCIA (*Il Policlinico*, Sez. Prat., November 1st, 1920), who records an illustrative case in a woman aged 40, agrees with Mayo-Robson that the symptoms of haemorrhagic pancreatitis are so indefinite as to render the diagnosis impossible. He regards, however, the following symptoms as suggestive: localization of pain and muscular resistance a little above and to the right of the umbilicus; a contrast between the gravity of the general condition and the relatively slight objective signs: intense cyanosis of the face and subnormal temperature, together with indicanuria and defect of the pancreatic function shown by steatorrhoea, glycosuria, and azoturia. A past history of recurrent attacks of epigastric pain with vomiting, tetanus, etc., and signs of a tumour between the xiphoid cartilage and the umbilicus makes the diagnosis still more certain.

116. Syphilis of the External Ear.

LUND (*Ugeskrift for Laeger*, October 21st, 1920) has observed in a year no fewer than 13 cases of syphilis of the external ear, the disease being secondary in 9 cases and tertiary in 4. He calculates that syphilis of the external ear occurs in about 2 per cent. of all cases of syphilis. As many as 9 of his 13 patients were women, and he notes that this preponderance of females has been observed by other writers, who explain it as the result of wearing long hair over the ears. One of the author's patients illustrated this point well; her hair formed a caked pad covering the ear. With regard to the differential diagnosis, most writers attach importance to enlargement of the adjacent lymphatic glands, but the author could find no great enlargement of the glands in the mastoid, submaxillary, or retromaxillary regions in any of his cases, which showed only slight general polyadenitis. In one case the papular eruption was confined to the external meatus; there was no middle-ear disease, no general secondary eruption, and no marked adenitis; Wassermann's reaction was negative, but syphilis was diagnosed because of the history, the specific appearance of the papules, and the recovery effected by antisyphilitic treatment. The author can find a record of only one similar case; the diagnosis was clinched in this case by the development of a typical secondary eruption a week after the appearance of papules on the ear (Beek, 1911). Syphilis of the external ear being comparatively refractory to general specific treatment, this may have to be supplemented by local application of calomel in the form of a powder, an ointment, or a solution of salvarsan in a compress. Local treatment with silver nitrate or concentrated chromic acid, as recommended in the textbooks, provokes pain without any therapeutic compensation.

117. Varicose Veins Treated by Intravenous Injections of Sodium Bicarbonate.

SICARD and PARAF (*Bull. Soc. Méd. des Hôp. de Paris*, November 18th, 1920), impressed by the results which followed injections of luargol, have treated many cases of varicose veins by intravenous injections of a 10 per cent. solution of sodium bicarbonate. To avoid silica contamination the solution should be sterilized in hard glass. The most important practical detail is to ensure that the solution should go into the vein alone and not the surrounding tissues, otherwise a troublesome slough may follow. The results were very successful, and no embolism, no toxic symptoms, and no widespread thrombosis was ever observed. Injections are given every day or every other day according to the necessities of the case. They are said to be painless, and the treatment requires no laying up, and can be carried out without interfering with the patient's work. After injection a brief cramp is sometimes noted. Varicose ulcers—at any rate, those up to a 5-franc piece in size—are very favourably affected, and the cosmetic effect is also satisfactory. Where there is a tendency to relapsing periphlebitis injections are contraindicated. As to the duration of the cure, cases which were injected in 1917 and 1918 still remain satisfactory.

118. Intestinal Obstruction due to Gall Stones.

ACCORDING to PINARDI (*Il Policlinico*, Sez. Chir., November 15th, 1920), who records two cases, the diagnosis of intestinal obstruction due to gall stones has hardly ever been made before operation, as there are no pathognomonic symptoms. Cholelithiasis fairly frequently causes symptoms of transitory or permanent intestinal obstruction. In some cases there is a dynamic paralytic ileus due to localized or generalized peritonitis following cholecystitis. More frequently there is a mechanical ileus due to occlusion of the duodenum or colon by peritoneal adhesions or to compression of the intestinal walls by a gall bladder distended by calculi or a mixture of bile and pus. Pinardi, however, does not discuss this form of intestinal obstruction, but only that form due to arrest of gall stones in the lumen of the intestine. This variety of intestinal obstruction, though known for a long time, is relatively infrequent. Among 1,152 cases of intestinal obstruction Leichtenstern found only 20 examples, Gonzales collected only 67 cases from the literature, and among over 400 cases of intestinal obstruction operated on at the Ospedale Maggiore, at Turin, Pinardi found only three cases due to this cause. The condition is most frequently, if not exclusively, found in persons over 40, especially of the female sex. The most frequent site of obstruction is the lower end of the ileum.

119. Treatment of Orchitis in Mumps.

IT is asserted by BALLENGER and ELDER (*Journ. Amer. Med. Assoc.*, November 6th, 1920) that the present method of treating orchitis caused by mumps is inadequate, as is shown by the large number of atrophied testes observed. The plan which they have adopted is to incise the tunica albuginea and relieve the pressure, and at the same time allow the escape of some of the toxic substances produced by the organisms which cause mumps. This must be done early in the disease before the necrotic process has become established, just as in strangulated hernia the operation should be performed early if resection of the intestine is to be obviated.

120. Long-standing Dislocations of the Hip.

BUCHANAN (*Surg., Gyn., and Obstet.*, November, 1920) believes that hip dislocations may be considered old at the end of four weeks; after that time reduction by manipulation is rarely successful, owing to a formation of connective tissue which fills the acetabulum and binds down the head and neck. Reduction by open incision is to be preferred in nearly all cases of old hip luxations, and with modern methods is attended with little danger. Preliminary traction by Buck's extension is of advantage. The replacing of the head after the acetabulum has been emptied and the head and neck have been released is best accomplished by manipulation or the use of levers; these may be combined with traction both by the surgeon's arms and by a band fixed to the patient's thigh and passing round the surgeon's neck and shoulder. In 45 cases reported the result was often ideal, and in 80 per cent. good.

121. Local Anaesthesia for Abdominal Operations.

WIDERÖE and BORCHGREVINK (*Norsk Mag. for Laegevidenskaben*, November, 1920) trace in detail the development of local anaesthesia in major operations, pointing out the salient features of the most modern methods. To show the extent to which local has replaced general anaesthesia in abdominal operations, they analyse the material operated on between April 1st, 1919, and April 1st, 1920, at the second Department of Ullevaal Hospital. Here 1,548 operations of all kinds were performed, 28 per cent. under general anaesthesia, 5 per cent. under ether or ethyl chloride partial anaesthesia, 3 per cent. under local anaesthesia plus partial general anaesthesia, 47 per cent. under local anaesthesia, and 17 per cent. without any anaesthesia. In 422 of the 1,548 operations, or 27 per cent. of the total, the operations were laparotomies. Of these, after the exclusion of 251 appendectomies, 67 per cent. were performed under local anaesthesia, supplemented in some cases by a little ether inhalation. The authors discuss separately the operations on the stomach, intestines, biliary organs, and the female reproductive organs, and show that only in 4 out of 28 gastro-enterostomies was general anaesthesia adopted. They also preferred to operate on the biliary organs under local anaesthesia. But most of their 251 appendectomies were performed under general anaesthesia, only 22 being performed under local anaesthesia. Gynaecological intrapelvic operations were also usually performed under general anaesthesia, but in two cases ovarian cysts were successfully removed without pain under local anaesthesia only.

OBSTETRICS AND GYNAECOLOGY.**122. Polycystic Ovarian Changes.**

AMOR (*Gaceta Médica de México*, April, 1920, and *Journ. Amer. Med. Assoc.*, October 2nd, 1920) emphasizes the clinical distinctions between sclero-polycystic ovaritis of gonorrhoeal origin and cystic degeneration of the ovaries of non-infectious origin. The former condition, he says, is characterized by rapid development of the sclero-polycystic change, this being accentuated by the premature menopause which is frequently induced; no surgical intervention is of use unless the whole organ is removed or panhysterectomy performed. In non-infectious cystic degeneration, on the other hand, the condition, which is associated with neuralgic pains, is generally traceable to repeated pelvic congestions and a nervous or gony diathesis; ovariectomy does not always effect a cure, while relief is often obtained as a result of simple laparotomy, ignipuncture of the ovary, stretching of the anus, or section of the sacral sympathetic.

123. An Unusual Mechanism of Labour in Placenta Praevia.

KATZ (*Zentralbl. f. Gynäk.*, October 9th, 1920) records two cases of placenta praevia in which the placenta was expelled before the foetus from the uterus. In the first patient, a 9-para, aged 41, haemorrhage, speedily followed by rupture of the membranes, occurred a week before term; the placenta was almost immediately expelled into the vagina, and its maternal surface presented at the vulva. The foetus, which presented by the breech, was born within a few minutes, enveloped in membranes which were intact save at the point of the original rupture. In the second, a 5-para, aged 30, had at term slight pains and some bleeding, followed three days later by a sharp haemorrhage and on the fourth day by rupture of the membranes. A severe bleeding now occurred, but became suddenly arrested: at the same time the vagina was found to be occupied by placental tissue, above which a knee was palpable. Extraction was performed through the placenta; in this, as in the first case, the subsequent course was satisfactory. Prolapse of the normally placed placenta is very rare, but Simpson in 1871 was able to collect 141 cases of birth of placenta praevia before that of the foetus.

124. Unusual Case of Urethral Stricture.

HEINRICHSDORFF (*Zentralbl. f. Gynäk.*, September 25th, 1920) records the case of a female patient, aged 65, admitted to hospital for retention of urine, due to an almost impermeable urethral stricture. Death took place two days later. At the autopsy the bladder showed great hypertrophy, the ureters and renal pelvis were distended, and there was double pyonephrosis. Serial sections through the stenosed part of the urethra and its internal orifice showed the existence amid thickened scar tissue of a fistulous communication between the bladder and vagina. The author concludes that the original cause lay more probably in obstetric trauma than in a gonococcal peri-urethral abscess.

125. Calcified Tubal Mole.

MAXWELL (*Surg., Gyn., and Obstet.*, October, 1920) records the case of a woman, aged 55, in whom laparotomy was performed for carcinoma of the cervix. The left tube was found to end in a calcified spherical mass about 3 cm. in diameter, closely adherent to the omentum. After removal the swelling, which was cut with a saw, was found to consist of a calcified shell about 5 mm. in thickness, containing a semi-translucent jellylike substance, with a thin, bright yellow layer just inside the capsule. Microscopical examination showed the presence of degenerated chorionic villi and the remains of a decidual reaction. Probably an ampullary pregnancy had been transformed into a tubal mole in which adherence of the omentum had prevented tubal abortion, and which subsequently became calcified. The patient had been sterile for twenty-five years; no history pointing to past tubal gestation was elicited.

126. Conjunctival Chancre in a Midwife.

GÉRARD (*Gaz. des Prat.*, August 1st, 1920) records the case of a healthy midwife in whom a series of conjunctival lesions were not recognized to be those of primary syphilis until thirteen weeks after their appearance. The only possible source of infection is said to have been the projection into the eye of amniotic fluid; this, however, is reckoned never to contain spirochaetes.

127. Threatened Rupture of Uterus in Premature Birth by Transverse Presentation.

WERNER (*Zentralbl. f. Gynäk.*, October 23rd, 1920) alludes to a case, occurring in the Wertheim clinic at Vienna, of rupture of the uterus as a sequel to transverse presentation; labour occurred in the sixth month of gestation, and manipulative treatment was deliberately withheld in the expectation that spontaneous delivery would ensue. Werner records a personal case in which the circumstances were similar, but in which the sudden appearance of signs of impending uterine rupture caused expectant treatment to be abandoned. A primipara of 26, four days after the advent of pains and seventeen hours after rupture of the membranes, was found to have a transverse presentation, with vaginal prolapse of a hand; uterine contractions were strong and frequent, the patient felt well, having a pulse of 102, and foetal heart sounds were present. It was resolved to await spontaneous delivery, but an hour later the pulse increased in frequency to 120, the temperature rose, the uterus became contracted so that the foetal parts were no longer distinguishable, the prolapsed hand became livid and oedematous, and the foetal humerus was found to be fractured. At the same time the foetal heart sounds disappeared and Baudl's retraction ring became palpable; the external os was found to grasp the shoulder very tightly and not to be readily dilatible. Decapitation was performed by means of Franz's instrument, for which the author has a preference. The labour is stated in this case to have been premature, but duration of the pregnancy is not mentioned; the foetus was 35 cm. long and weighed 1,270 grams. The author concludes that in the case of premature labour it is not justifiable, even at the twenty-eighth week, to expect spontaneous expulsion; in such cases there is grave risk of a rupture of the uterus. With regard to the vaginal findings, he quotes a case of distension of the lower uterine segments with unruptured membranes (GOLDNER, *Monatsschr. f. Geburts. u. Gynäk.*, 1904, xviii, 4), and alludes to Murray's case (BRITISH MEDICAL JOURNAL, January 11th, 1902) of rupture of the uterus in the absence of cervical dilatation. On the other hand, spontaneous delivery, as a shoulder presentation, has been described in a child of 8½ lb. at term.

128. Extended Hysterectomy after Radium Treatment of Cancer of the Cervix.

GRAVES (*Amer. Journ. of Obstet. and Gyn.*, November 1920) has operated on a number of cases of cervical cancer (whose operability was near the borderline) within a few days of the application of radium; of such operations, three consecutively were followed by acute post-operative peritonitis, fatal in one case. Since this experience the author has waited before operating for at least three or four weeks after the last radium treatment, as recommended by Wertheim. Several applications of radium were found to be followed in a few weeks by extensive parametrial sclerosis, but a single moderate dose interferes much less with the ease of the operation. In frankly operable cases Graves is not convinced of the value of preoperative treatment by radium.

PATHOLOGY.**129. Amyotonia Congenita.**

HOLMES (*Amer. Journ. of Dis. of Children*, November, 1920) has made full histological studies of the tissues obtained at autopsy in a child suffering from amyotonia congenita (Oppenheim's disease). The spinal cord was relatively large for the age of the child (18 weeks), and the anterior roots were diminished in size as compared with the posterior; there was no naked-eye or microscopic evidence of an inflammatory process, acute or chronic, or of recent degeneration. Myolization was normal, and the cells of Clarke's column were well preserved. In the anterior horn large cells were few, and in part were represented by cells of much smaller size, but similar appearance; cells of the normal size, although infrequent, showed the usual characters. The findings in the muscles were in accord with those made by PEARCE (*Ibid.*) in muscle fragments removed during life from another subject of this disease: areas consisting of bundles of hypertrophied but otherwise normal muscle fibres were mingled with small but otherwise healthy fibres which appeared to represent an imperfect stage of development. There was no evidence of a present or past degenerative process, no increase in connective tissue; there was no replacement of muscle tissue by adipose tissue, and the configuration of the brain was normal. In Holmes's case the microscopic appearances

of the musculature of the diaphragm were normal. In Pearce's paper records are given of five cases of amyotonia congenita: two were twins. Pearce agrees with Hucnckens that clinically there is no sharp differentiation between the Werdnig-Hoffmann and the Oppenheim types of disease. In a subsequent paper (*Ibid.*, December, 1920) Holmes forms the conclusion that Oppenheim's and Werdnig-Hoffmann's diseases are extreme types of the same disorder, and that they are probably both related to the group of myopathies represented by Erb's juvenile form of muscular dystrophy and the hereditary form of Leyden and Moebius.

130. Gastric Papillomatosis.

DU BRAY (*Arch. of Int. Med.*, August 15th, 1920) records an interesting case of the rare adenoma of the stomach. Full notes are given of the clinical condition, on which a diagnosis of gastric carcinoma was founded. At operation the true nature of the neoplasm was suspected, and frozen sections confirmed the benign nature of the condition. The tumour mass, which measured about 4 in. in diameter, was found on the greater curvature, and appeared as closely-packed papillomatous growths thrown into folds, and resembling brain cortex in colour and contour. The individual papillomata traced to their bases appeared to be outgrowths from normal mucosa. Microscopically the sections showed a hypertrophy and papillomatous arrangement of the mucosa. The tubular glands were greatly elongated, with much branching and corkscrew formation. Stroma was minimal in amount, and there was no involvement of the musculature. Such benign tumours are frequently accompanied by no abnormal symptoms, and are mostly discovered *post mortem*.

131. Complement Fixation Reaction in Lupus.

ICHOK, GOLDENBERG, and FRIED (*C. R. Soc. Biologie*, November 6th, 1920), in view of the fact that it is difficult to give an experimental demonstration of the tuberculous nature of lupus, which is due either to the small number of tubercle bacilli contained in the lesion or to an attenuation of the virulence of such bacilli, set themselves to find out if the body of a patient affected with such an attenuated tuberculosis was capable of producing specific antibodies. The presence of such antibodies in lupus has been denied. The authors were fortunate in being able to examine no less than 104 cases of lupus. Using Besredka's antigen—an emulsion of tubercle bacilli grown in Besredka's egg-broth—and the usual complement deviation technique, they found that 69 serums gave a positive reaction (66.4 per cent.), 18 gave a partial reaction (17.3 per cent.), and 17 were negative (16.3 per cent.). Amongst their cases, varying from 10 to 74 years of age, not one presented clinical symptoms of a tuberculous localization other than in the skin. In the great majority of cases the disease had existed for more than ten years, sometimes for thirty to forty years. In spite of the mere or less considerable extent of the cutaneous lesion and of its tenacity, the rest of the body always appeared free from tubercle. It may be that the body is somehow vaccinated by the circumscribed attenuated infection. Owing to its power of resisting tuberculous reinfection in the majority of cases, the body of a person with lupus is different from that of the normal unaffected individual, and this is corroborated by the positive sero-diagnostic reaction. It is an open question whether the presence of antibodies is an evidence of a still active focus of tuberculosis or of an active resistance preventing the extension of the tuberculosis to other organs.

132. The Meinicke and Sachs-Georgi Reactions.

HAJOS and MOLNÁR, jun. (*Wiener klin. Woch.*, October 28th, 1920), from a comparative examination of the Wassermann, Meinicke, and Sachs-Georgi reactions in several hundred cases, came to the following conclusions: (1) Meinicke's reaction, and still more so the Sachs-Georgi reaction, is a much simpler method than the Wassermann reaction. (2) The sensitiveness of the Meinicke and Sachs-Georgi reactions is somewhat less than that of the Wassermann reaction. (3) The Meinicke reaction is less specific than the Wassermann reaction, but the specificity of the Sachs-Georgi reaction is equal to that of the Wassermann reaction. (4) The Sachs-Georgi reaction can be employed for examination of the cerebro-spinal fluid, whereas the Meinicke reaction is not available for this purpose. (5) The Wassermann reaction cannot at present be replaced by the other two reactions, but the Sachs-Georgi reaction is a valuable supplement, and should always be carried out at the same time as the Wassermann reaction, as in many syphilitic cases it may give a positive result when the Wassermann reaction fails to do so.

EPITOME OF CURRENT MEDICAL LITERATURE.

MEDICINE.

133. Bronchial Asthma.

GIUFFRÉ (*Rif. Med.*, November 20th, 1920), at the recent medical congress held in Rome, in opening a discussion on bronchial asthma, dealt chiefly with the pathogenesis of the disease. He believes it is a respiratory neurosis and not an anaphylactic state. He went on to discuss the reflex, anaphylactic, and endocrinic theories; with one or other of these three theories most cases of asthma can be explained and the genesis of the various symptoms understood, including bradypnoea, coryza, bradycardia, cosinophilia, hemicrania, etc. Only a few cases can be explained on one hypothesis: usually two, or even all three, of the theories are needed to explain all the symptoms in any given case, and where fever and bronchitis exist this may be due to bacterial infection. However varied the causes and the symptomatology the hyperkinesis and bronchial hyperemia remain the chief fundamental facts. Without a special hyperexcitability of the respiratory neurones one does not get a true asthma. FATGONI, continuing the discussion, excluded asthma due to some other fundamental disease and pure respiratory neurosis—for example, asthmatic crises in hysteria. Causes may be grouped as disposing and determining. Thyroid or ovarian disturbances, if not directly determining asthma, may favour its development. Tuberculosis and asthma are not as antagonistic as was at one time believed, nor can nasal lesions be accepted as prime causes. Pollen asthma is well established both on clinical and experiment grounds, so also with regard to animal exhalations. About half the cases of asthma still remain to be explained etiologicaly. None of the alien elements in the sputum (Charcot's crystals, etc.) are pathognomonic although characteristic. Where a specific pollen or protein can be detected vaccine treatment gives excellent results, and adrenalin and pituitrin are sometimes valuable symptomatically.

134. Treatment of Chilblains.

CLAP (*Bull. Soc. de Thérap.*, December 8th, 1920) states that during the war he several times relieved the pain caused by this affection in soldiers by applying an elastic bandage either directly over the chilblains or above them. The results were equally good in both cases. Local compression acted more rapidly but was more painful, while the effects of compression at some distance from the chilblains were more lasting. The former method was indicated when there were only a few lesions on the fingers or sides of the feet, while the latter should be reserved for multiple chilblains, chilblains on the toes, and ulcerated chilblains.

135. Epidemic Hiccough at Rheims.

RAILLIET (*Bull. et Mém. Soc. Méd. des Hôp. de Paris*, December 30th, 1920) states that the first cases occurred on November 10th, and that the epidemic reached its height at the beginning of December. About 130 cases had occurred at the time of his communication, when the epidemic was beginning to decline. The average duration of the hiccough was from two to four days. In two cases, however, it lasted eight and ten days respectively. In some patients the hiccough persisted throughout the day and night, while in others there were periods of quiet either by day or night. More cases occurred in men than in women. Children were apparently immune. The majority of the cases were not subject to the ordinary form of hiccough, and were vigorous persons without any history of digestive or nervous disturbances. At the time of the attack, however, several patients suffered from mild or severe gastric symptoms. Most of the ordinary sedatives were ineffectual, such as belladonna, chloroform water, camphor, and valerian. Mixtures containing menthol, cocaine, or heroin were sometimes successful, and good results were also obtained by emetics in some cases. Various suggestions have been made as to the cause of the condition, including cold, intoxication by water, bread, ergotism, neuropathy, and a monosymptomatic manifestation of influenza or lethargic encephalitis.

136. Epidemic Encephalitis in Anjou.

DENÉCHAU and BLANC (*Bull. et Mém. Soc. Méd. des Hôp. de Paris*, December 30th, 1920) record their observations on 31 cases of epidemic encephalitis in Anjou, where

50 cases occurred in 1919-20. The predominant feature was motor excitement. Myoclonic movements were the principal manifestation, and were associated with muscular hypertonus. Choreic movements were noted in 5 cases and hiccough in 2; 6 patients showed signs of paralysis agitans, one case simulated generalized epilepsy, and one Jacksonian epilepsy. Ocular symptoms were seen in 22 cases, and consisted in isolated paralysis of the ocular muscles, affection of the iris and ciliary muscle, and in 3 cases paralysis of associated movements. Mental symptoms were found in 14 cases, either in the acute stage in the form of excitement with a dream-state delirium and visual hallucinations, or in the late stage. Death occurred in 11 cases, or in 34 per cent. The survivors all showed sequelae, which were as follows: (1) Psychological symptoms in 6 cases, (2) ocular paralysis, (3) paralysis agitans, (4) muscular atrophy.

137. Small-pox and Tuberculosis.

HOWK and LAWSON (*Amer. Rev. of Tuberculosis*, September, 1920) report 7 cases of small-pox which occurred in a sanatorium in 1914. All the 7 patients recovered from small-pox, and 6 were alive and well in September, 1920. The symptomatology, the appearance of the exanthem, and the duration of the small-pox were not influenced by the presence of tuberculosis. In one active advanced case the attack of small-pox was followed by a disappearance for four months of sputum and tubercle bacilli; in another advanced case, hitherto progressing rapidly, a permanent disappearance of sputum and bacilli took place immediately after the attack of small-pox.

138. Tuberculin Treatment.

ACCORDING to DE BLOEME (*Nederl. Tijdschr. v. Geneesk.*, October 2nd, 1920) tuberculin treatment can be most safely employed in cases of pulmonary tuberculosis in which the general condition is good, the pulse is not frequent, there are no complications, there are no tubercle bacilli in the sputum, and there is a tendency to recovery. It is contraindicated in acute cases or relapses of pulmonary tuberculosis in which the rectal temperature is continuously above 99.8° F. Cases with a frequent pulse and nephritis are also unsuitable. De Bloeme recommends tuberculin for localized forms of tuberculosis—for example, of the skin, lymph glands, and especially the eye. As regards tuberculosis in children, he alludes to von Leube's suggestion that all children of tuberculous parents who give a positive von Pirquet reaction should be given tuberculin.

139. Consecutive Bilateral Artificial Pneumothorax.

FELDMANN (*Tuberculosi*, August, 1920) reports the case of a woman, aged 31, first seen in July, 1916, when she showed signs of phthisis, chiefly in the right lung (diminished expansion, slight dullness at the apex, crepitations; on the left side harsh breathing at the apex, but no adventitious sounds). The radiograms showed opacity of the middle lobe on the right side, and some opacity of the left apex. The symptoms dated back four years. Artificial pneumothorax was induced on the right side; the signs and symptoms improved very much. The lung collapsed in about three weeks. In January, 1917, a few râles were detected at the left apex, and as the right side was so much better, treatment on that side was stopped; after six weeks the lung resumed its original volume, and the radiograph showed evidence of sclerosis in the previously diseased area. About the end of February pneumothorax was induced on the left side with excellent results, so that at the beginning of March, 1918, no further treatment was necessary. The patient has remained well so far.

140. Contraindications to Dental Extraction in Cardiopaths.

CALPY (*Rif. Med.*, September 4th, 1920) draws attention to the danger of septic poisoning from dental extraction and the possibility of the germs spreading to the myocardium and so weakening an already damaged heart. He quotes two cases (one fatal) where after extraction of a tooth fever and septicaemia set in. He suggests that where cardiac compensation is not very sound it is better to drain the dental abscess rather than proceed to extraction, which exposes more of the septic alveolus. Later on, when as a result of drainage the region of the tooth is less septic, it can be extracted.

141. Bilateral Peripheral Facial Paralysis.

ASKGAARD (*Hospitaltidende*, September 8th, 1920) discusses de Castro's thesis, published in 1919, in which he calculated that 95 per cent. of all cases of bilateral peripheral facial paralysis are due to syphilis. The author's material is not great enough to refute this indictment, but he records a case in which syphilis could be definitely excluded. The patient was a man, aged 35, who denied having contracted syphilis, and who gave a negative Wassermann reaction. He had been perfectly well till he contracted severe bronchitis, for which he had to go to bed. During this illness, first the left, and two days later the right facial nerve became paralysed. There were no giddiness, headache, loss of consciousness, diplopia, nor convulsions, and the electrical reaction of degeneration could not be elicited. Within ten days of coming to hospital the right side of the face had become almost normal, but there was still evidence of paralysis on the left side. This case is regarded by the author as "rheumatic"—a term which he admits is a confession of ignorance. The bronchitis was probably a predisposing factor. In another of the author's cases the development of bilateral facial paralysis coincided with a secondary eruption of syphilis, with which the author correlated the paralysis without question. Though he does not specifically reject de Castro's estimate of the part played by syphilis in bilateral facial paralysis, the author maintains that in most cases of unilateral peripheral facial paralysis the cause is rheumatism.

142. Adrenalin in Erythromelalgia.

CHATELLIER (*Ann. de Derm. et de Syph.*, 1920, No. 5) records the case of a neuropathic woman, aged 23, suffering from violent attacks of erythromelalgia which were not affected by ordinary analgesics, such as aspirin, pyramidon, and morphine, but were rapidly cured by a subcutaneous injection of $\frac{1}{2}$ mg. of adrenalin.

SURGERY.**143. Benign Intestinal Tumours.**

VAN LIER (*Nederl. Tijdschr. v. Geneesk.*, November 27th, 1920) states that the diagnosis of intestinal tumour is too frequently regarded as a sentence of death, the possibility of a benign growth not being taken into consideration. Statistics, however, show that 20 per cent. of all pyloric tumours are benign. In the course of the last six months van Lier has seen three cases of advanced pyloric stenosis in elderly persons due to benign tumours and cured by gastro-enterostomy. Benign tumours of the ileum practically never occur, the growths in this part of the intestine being usually sarcomata. The colon from the caecum to the anus may present inflammatory swellings, of which perisigmoiditis is the most frequent. Van Lier records a case of stricture of the sigmoid to show the falsity of the old doctrine that all strictures of the large intestine are due to syphilis or tuberculosis. The Wassermann reaction was negative, and the *post-mortem* examination showed the absence of any malignant growth. Cohnheim (1915) also states that non-specific colitis and proctitis may give rise to stenosis.

144. Luxations of the Thumb.

GUIBÉ (*Rev. d'Orthopéd.*, 1920, 7) discusses at great length the dislocations and subluxations of the terminal phalanx of the thumb. A very clear account is given of the anatomy and workings of the interphalangeal joint. Backward dislocation is of course the common displacement, and whilst a large number of these injuries are reduced at once by the patient himself or his friends a certain number there are in which the phalanx remains out of position. Guibé clearly shows the mechanism of these unreduced cases by x-ray photographs of experimental luxations on autopsy material. There is never any difficulty in reducing the dislocation. An open operation is indicated, a flap being turned down on the dorsal aspect and the long flexor tendon carefully preserved. Dislocation of the terminal phalanx forwards is very uncommon, and lateral luxation still rarer. The number of forward dislocations reported is scarcely more than six, so that those who have seen examples of this displacement should record them without delay.

145. Syphilitic Polyneuritis.

ACCORDING TO KERL (*Wien. klin. Woch.*, October 14th, 1920), who records a personal case, the occurrence of syphilitic polyneuritis, which was first described by Ehrlich in

1886, is a rare event, only 11 cases having been collected by Steinert in 1909, and 20 by Demanque and Menard in 1911. In most of the cases the polyneuritis appeared after the syphilitic eruption, and there are only four cases on record in which it developed before or at the same time as the rash. Kerl's patient was a woman aged 45, who suddenly developed peripheral paralysis of the right upper and lower extremity and of the right facial nerve in all its branches. Two days later a generalized maculo-papular eruption appeared, together with a sore throat. The Wassermann reaction was positive in the blood though negative in the spinal fluid. Mercurial neuritis could be excluded, as the patient had not had any previous treatment and was not engaged in any trade in which mercury was employed. Other causes, such as alcohol and rheumatism, could also be excluded. The syphilitic nature of the polyneuritis was confirmed by the rapid recovery following antisyphilitic treatment.

146. Volkmann's Contracture.

IN opening a discussion at the French Orthopaedic Congress, DENUCE (*Gaz. hebdom. des Sci. Méd.*, November 7th, 1920) said that Volkmann's contracture, attributed by Volkmann to myogenous causes connected with ischaemia, had been ascribed, in part at least, by Bardenheuer and Hildebrand to nervous affection. During the war it had been found that Volkmann's contracture occurred in adults as well as in children; in the lower as well as the upper limbs; with or without preceding fracture or application of splints. Nervous lesions coexisting with Volkmann's contracture might (1) be due to the contracture; (2) be associated with it, both being due to some third cause; (3) cause the contracture. Denucé believes that while ischaemia may be the cause of flaccid palsies, paralyzes with contracture (and especially those associated with much fibrosis) are due, in some degree, to interference with sympathetic nerves. According to Morat and others muscle tonus is regulated by a reflex, of which the afferent and efferent paths are situated in both the spinal and sympathetic nerves. These sympathetic fibres are to be found both in the spinal nerve trunks and in the perivascular nervous plexuses. Too tight application of a splint, by interfering with vascular expansion, might lead to functional troubles of the sympathetic. Leriche, in his work on periarterial sympathectomy, has shown that for contraction of voluntary muscle there is necessary, besides integrity of the muscle and of the motor nerve, integrity of the perivascular sympathetic filaments. From an examination of cases Denucé found that in the majority of instances there had been fracture, with irritation of nerve or arterial trunks by the displaced bony segments or by splinters. For treatment he advocated tenoplastic operations (associated if necessary with neurolysis) or, in the cases associated with extensive fibrosis, the sympathectomy of Leriche.

147. Dissecting Abscess of the Caecal Wall.

HAGLER (*Surg., Gyn., and Obstet.*, November, 1920) records the case of a young male in whom acute appendicitis was diagnosed. Operation was performed within twenty-four hours; the appendix was slightly injected, but the caecum was greatly enlarged and fluctuant. The swelling was found to be due to a collection of pus between the circular muscle layer and the submucosa; there was no evidence of gangrene or perforation. The post-operative course was regular.

148. Colloidal Gold in Septicaemia.

LAY (*La Clinica Chirurgica*, March-April, 1920) employed intravenous injections of colloidal gold in 9 cases of septicaemia. In 5 cases the results were excellent, the first being due to the typhoid bacillus, the second to the paratyphoid B bacillus, the third to *Staphylococcus albus* and streptococcus, and the fourth to *Staphylococcus aureus*, while in the fifth case, which was that of a wound of the arm due to an explosive bullet, no bacteriological examination was made. After each injection there was intense shivering and rise of temperature, followed by a rapid fall, accompanied by profuse sweating and a sense of comfort. The wounds became clear after the first or second injection. No cases of intolerance were observed.

149. Herpes Ophthalmicus.

ROELOFS (*Nederl. Tijdschr. v. Geneesk.*, December 25th, 1920) records the case of a girl, aged 12, who, three days after getting some soda in the right eye, developed right ophthalmic zoster, and about a fortnight later external and internal ophthalmoplegia of the right eye, an affection of the cornea closely resembling the keratitis punctata superficialis of Fuchs, and slight atrophy of the iris, the

result of inflammation. The Wassermann reaction was negative in the blood and cerebro-spinal fluid. A pleocytosis of 30 was found in the cerebro-spinal fluid. Improvement took place, but fourteen months after the onset the right pupil was still sluggish and irregular in shape, and accommodation was difficult with the right eye.

150. Operation for Detached Retina.

CHAPMAN (*Canadian Med. Assoc. Journ.*, November, 1920) records two cases of detachment of the retina treated, according to the method of Thomson and Curtin, by trephining the sclera (after raising the conjunctival flap) and repeated aspirations. The first case was one of extensive detachment in a man aged 47; six weeks after the trephining there was no dimness of vision in any area, and central vision was $\frac{3}{80}$.

151. Intermittent Intestinal Obstruction caused by Murphy's Button.

NEUBERGER (*Wien. klin. Woch.*, November 4th, 1920) reviews the literature, and records the following case: A man had a portion of the large intestine resected for a tumour in August, 1906, anastomosis being made with a Murphy's button. The patient made a good recovery, and it was not until August, 1919, that he began to suffer from intermittent attacks of intestinal obstruction of increasing severity. As the x rays showed the presence of a Murphy's button in the left hypogastric region, laparotomy was performed thirteen and a half years after the first operation, and the button was found in a diverticulum of the transverse colon projecting into the lumen of the gut. After its removal complete recovery took place. Kelling's case, in which a Murphy's button was removed fifteen and a half years after the operation, is the only instance of a longer stay of this foreign body in the intestine.

OBSTETRICS AND GYNAECOLOGY.

152. Intestinal Obstruction and Peritonitis in Pregnancy, Labour, and the Puerperium.

ACCORDING to KÖHLER (*Wien. klin. Woch.*, October 21st 1920), intestinal obstruction is a rare complication of pregnancy, labour, and the puerperium, less than a hundred cases having been recorded. Apart from peritonitis of appendicular origin, which is not uncommon, diffuse peritonitis in pregnancy is still rare. Köhler records two cases of peritonitis and four of intestinal obstruction complicating pregnancy and the early or late stage of the puerperium, all of which were fatal. There does not appear to be any definite connexion between the number of confinements and intestinal obstruction. The age of the patient has also no importance, and it was a mere coincidence that three of Köhler's cases were in the fourth decade. On the other hand, the early stage of the puerperium is a predisposing factor, as the majority of cases have occurred between the second and ninth day after delivery. In most cases the association of intestinal obstruction and peritonitis with pregnancy, labour, and the puerperium is merely accidental, intestinal obstruction usually being due to the same causes as in the non-pregnant state, and in only a few instances to the enlarged uterus alone. The association has an unfavourable prognosis. As regards treatment, delivery by vaginal section is best. Operation is indicated in apparently hopeless cases, if only to save the life of the child. It is remarkable that even in diffuse peritonitis during pregnancy injection of organic extracts such as enteroglandol, though having no effect on the paralysed intestinal muscles, acts powerfully on the uterine muscles, and enables a child to be born.

153. Glycosuria in Pregnancy.

ANDÉRODIAS and DUBREUIL (*Gaz. hebdom. des Sci. Méd. de Bordeaux*, January 2nd, 1921) state that the association of glycosuria and pregnancy may take place under two different conditions—namely, (1) a woman who has been previously diabetic may become pregnant, (2) a hitherto healthy woman may develop glycosuria in the course of one or several successive pregnancies. Both of these occurrences are rare, the writers having seen only two examples during the last twenty years. In the first case a diabetic woman, whose urine contained 20 to 40 grams of sugar per litre of urine, gave birth to a full-term macerated foetus weighing 7 kilos, which had died *in utero* eight days before birth. In the second case the woman had had glycosuria during her last two pregnancies

but had shown no other signs of diabetes, and the urine, apart from pregnancy, had been normal. Examination of the urine before the birth of her fourth child showed an amount of sugar ranging from 50.75 grams and 52 grams per litre. A stillborn child, weighing $5\frac{1}{2}$ kilos, was born at the end of the eighth month. Examination of its pancreas showed enormous enlargement of the islands of Langerhans, the function of which is to control the sugar content of the blood.

154. Detachment of the Placenta by Gabaston's Method.

As early as 1826 an Italian, Benedetto Mojon, described a method of detaching the placenta by the injection of cold water into the umbilical vein. This method fell into abeyance, and was rediscovered in 1914 by Gabaston of Buenos Aires. Between April, 1916, and March, 1920, W. GEJROT (*Hygiea*, October 16th, 1920) has tested this method in the Communal Maternity Hospital in Stockholm. The fluid injected was sterile water cooled to a temperature of 12 to 15° C. The quantities injected ranged from 300 to 600 c.c.m. The method was adopted only when there was considerable delay in the spontaneous expulsion of the placenta, so that it could be tested only in 14 out of almost 3,000 births. In 7 cases there was only retention of the placenta: in the remaining 7 haemorrhage, as well as retention, was the indication for this treatment. In one of the 7 cases in the first class the injection failed of its object owing to pathological changes in the placenta. In 5 cases detachment of the placenta was successfully effected, and in one manual detachment was necessary, probably because the patient was too debilitated by illness to react to the stimulus of the injection. Of the 7 cases of haemorrhage, 4 reacted satisfactorily to the injection by detachment of the placenta. In the remaining 3 this device proved futile. In all the successful cases the injection was almost immediately followed by powerful labour pains. The author considers that the distension of the placenta by the fluid is the main factor determining the success of this treatment, but it is probable that the coldness of the injected fluid also helps to promote contractions of the uterus.

155. Hydatidiform Mole in association with Ovarian Cysts.

DAVARIS (*Gynec. et Obstét.*, 1920, ii, 1) records the case of a 24-year-old woman, who suffered during the third month of pregnancy from slight haemorrhage, albuminuria, vomiting, and tachycardia; the size of the uterus increased with undue rapidity. After induction of cervical dilatation a hydatidiform mole weighing 1 kilogram was removed digitally. Uterine involution took a normal course, but one month later the abdomen was opened for torsion of an ovarian cyst, and subtotal hysterectomy was performed. There were large cysts of both ovaries, and a cancerous condition was present in one part in the uterine mucosa. JEMTEL (*Gynec. et Obstét.*, and *L'Année méd. de Cuen*, June, 1920) has operated on two patients for hydatidiform mole associated with large bilateral ovarian cysts. In the first patient an unduly enlarged uterus, afterwards proved to contain a hydatidiform mole, was removed at the same time as the ovaries. In the second case, that of a woman aged 26, whose last confinement had occurred six months previously, expulsion of a hydatidiform mole was followed by persistence of uterine and adnexal enlargement and of haemorrhage.

156. Pyelonephritis following Pregnancy Cured by Intravenous Injections of Urotropine.

CARLES, CREYN, and FRANÇOIS (*Gaz. hebdom. des Sci. Méd. de Bordeaux*, January 2nd, 1921) report the case of a woman, aged 30, who as the result of a difficult labour contracted a vesical infection, and three weeks after delivery developed pyelonephritis with signs of severe infection, typhoid state, high temperature, rapid pulse, intense haematuria, and pyuria. Intravenous injections of urotropine were given daily, and later every two days, in doses of 2 to 10 c.c.m. of a solution containing 0.10 cg. of urotropine per cubic centimetre of distilled water. In five days' time the temperature fell, the urine became clear, and complete recovery took place.

157. Viability of Spermatozoa.

NERNBERGER (*Monatsschr. f. Geburts. u. Gynäk.*, July 5th, 1920) was able to demonstrate the presence of living spermatozoa in normal Fallopian tubes in the case of two patients who underwent laparotomy fourteen and fifteen days respectively after the last possible date of sexual intercourse.

PATHOLOGY.

158. Diabetes and Infections.

CASTRONUOVO (*Rif. Med.*, October 9th, 1920) holds that in considering the etiology of diabetes we ought to pay more attention to the immediate and late effects of infectious diseases, especially malaria, tuberculosis, and syphilis. Unsuitable diet in relation to climate should also be borne in mind, as it may induce changes in the digestive organs and lessen the power of the defensive organs to deal with infective poisons. In this respect the liver and pancreas are chiefly at fault. The tuberculosis which is often seen in diabetics should be looked upon as a precedent condition, although latent, rather than an effect of the diabetes; hence the importance of careful search for latent malaria, tuberculosis, or syphilis, and of treatment of these as a preventive of diabetes.

159. A Rapid Sero-diagnostic Method in Tuberculosis.

GOLDENBERG and FRIED (*C. R. Soc. Biologie*, November 6th, 1920), who previously reported 94 per cent. of positive results in 150 cases of pulmonary tuberculosis, have tried more recently a more rapid method, which consists in employing the unheated serums as the source of complement. Seeing that unheated human serum is very variable in its effect on sheep corpuscles, it was necessary to find out for each serum its haemolytic index in order to be sure that it was neither too great nor too feeble. A human serum that in doses of 0.1 c.cm. to 0.2 c.cm. can dissolve 0.6 c.cm. of a 5 per cent. suspension of sheep corpuscles serves very well for the rapid reaction. The authors put 0.1 c.cm. of the serum to be examined into each of three haemolysis tubes and add increasing doses of Besredka's antigen—namely, 0.1 c.cm. in the first, 0.2 c.cm. in the second, and 0.3 c.cm. in the third. After the tubes have been incubated for an hour the suspension of sheep corpuscles is added in doses of 0.3 c.cm., 0.2 c.cm., and 0.1 c.cm. respectively. After half an hour's incubation the results are read. The human serums should be examined within twenty-four to thirty-six hours after bleeding, because after that they lose a great part of their complement. Of 153 serums from cases of pulmonary tuberculosis, 8 were rejected because they were either too haemolytic or had practically no haemolytic effect. Of the remaining 145 serums, 137 gave a positive fixation (93.75 per cent.), and 8 gave a negative result. In all these negative cases the patients died within a few weeks of the test. In cases of surgical tuberculosis 100 per cent. positive results were obtained. In 19 serums from diseases other than tuberculosis the results were always negative. The authors consider that the rapid method gives as good results as the slower complement deviation method. In making their comparison they used the same serums for both methods.

160. Haematogenous Renal Infection.

PEDROLLI (*La Clinica Chirurgica*, March-April, 1920) records 15 cases of haematogenous renal infection, of which he considers the staphylococcus to be the most frequent causal organism. He attaches considerable importance to factors which cause an obstruction to the flow of urine, such as pregnancy, movable kidney, and calculus. The most frequent macroscopical lesions are the diffuse nodular form and a focal form. The course of the disease is subacute. The best treatment is nephrotomy and nephrectomy, after which the prognosis is favourable.

161. Histological Changes Produced by Salvarsan.

KOLMER and LUCKE (*Arch. of Derm. and Syph.*, September, 1920), as the result of their experiments on animals with single and repeated injections of salvarsan preparations, state that the changes produced in the tissues by products of the neo-salvarsan order are of the same character as, though of a much less severe degree than, those produced by salvarsan. Acid or non-neutralized solutions of the latter caused in all organs severe vascular injuries characterized by congestion, haemorrhagic extravasations, and thrombi. Single large doses of both drugs produced similar but less marked changes, but areas of focal necrosis and cellular degenerations in heart muscle, liver, and spleen were rather prominent; the kidney lesions consisted of these changes as well as varying degrees of tubular necrosis, and the suprarenals showed in addition well-marked changes in the lipoid and chromaffin contents. When multiple small doses of the drugs were given, similar vascular, renal, and suprarenal lesions resulted, and focal areas of cellular degenerations and necroses were frequently well

marked in the heart and liver. The maximum changes were produced by large doses of acid solutions much greater than those which would be employed in treatment, but multiple injections of therapeutic doses were not without definite effects.

162. Familial Tabes.

BURROW (*Journ. of Neurology and Psychopathology*, November, 1920) records the medical history of six surviving members in a family of eight, born of healthy parents; four have acquired syphilis from different sources, with resulting tabes dorsalis. A fifth acquired gonorrhoea and possibly syphilis; it is probable that he now suffers from early tabes. A sixth escaped venereal infection and remains healthy. It is suggested, in the light of the above record, that tabes dorsalis cannot be attributed to a special strain of spirochaete acting on tissues specially sensitized, either by natural family peculiarity, or by certain methods of treatment.

163. Diagnosis of Bubonic Plague.

VIOLLE (*C. R. Soc. Biologie*, October 16th, 1920) says that, though the investigation is easy when the bubo is recent, yet with old lesions the indirect method of demonstrating the infection, by agglutination, precipitation, or complement deviation, is very uncertain. He states that not only is the bubo the focus for the development of the plague bacillus, but it is also the site of the presence of the antibodies, which only later gain the general circulation. The reaction phenomena would thus seem to be primarily local. He finds that positive agglutination reactions may be obtained with the liquid extract of the bubo. The method is easy to follow; it is the ordinary serum-agglutination method, but in this case the serum is replaced by the bubonic pus. The reaction is positive with the pus from lesions several days or even several weeks old; it is negative with the juice of recent buboes. It is never obtained with the pus of cases of adenitis due to other organisms.

164. Protein Sensitization in Eczema.

RAMIREZ (*Arch. of Derm. and Syph.*, September, 1920) calls attention to the clinical applicability of protein sensitization to the investigation of eczema. As our present knowledge of the etiology and specific treatment of eczema is so vague, any method that will give us a clearer understanding of the condition is worthy of note. Various American observers during the last few years have laid stress on the relation of anaphylaxis to eczema, and have maintained that the majority of cases of chronic eczema are due to food sensitization. It is obvious that the more extensive the list of food proteins used in the skin scarification tests the higher will be the percentages of positive reactions. Ramirez tested 78 cases of eczema with food proteins and obtained 30 positive skin reactions, the greater majority of these being produced by more than one protein. He is of opinion that only a small percentage of all eczema cases are anaphylactic; when the eczema is associated with asthma or hay fever it is usually anaphylactic, and true anaphylactic eczema occurs more frequently under the age of 30. The treatment consists solely in the removal from the diet of the particular proteins giving the positive reaction.

165. Central Neurofibromatosis.

CHRISTIN and NAVILLE (*Ann. de Méd.*, July, 1920), who record five personal cases, state that in sixteen cases of central neurofibromatosis where information was available the onset was always before the twentieth year. As regards the duration of the disease, one should bear in mind the great length of the latent period or stages of arrest which may follow the first symptoms. Of 18 cases 11 lasted less than four years, 3 from five to ten years, one terminated after twenty-three years, and one after twenty-seven years. The prognosis is very bad, as out of 14 cases 8 died before 20, 2 between 21 and 30, 2 between 31 and 40, and 2 between 41 and 50. Bilateral central deafness was noted in 16 out of 23 cases, in 4 there was unilateral deafness, in 3 no definite information was available. Vestibular symptoms are very frequent, but are not so pronounced clinically. In spite of the size and extraordinary number of the endocranial tumours present in such cases there is a frequent absence of intense cerebral disturbance or of torpor and somnolence. All other cranial or spinal nerves may be affected. In less than two-fifths of the cases cutaneous neurofibromata were associated with endocranial lesions. A familial or hereditary character was found in several of the cases.

EPITOME OF CURRENT MEDICAL LITERATURE.

MEDICINE.

166. Vaccine Treatment of Typhoid Fever.

LUNA (*La Pediatria*, August 1st, 1920) reports on 175 cases of typhoid fever in children treated by Di Cristina and Caronia's vaccines. The cases were classified in four groups—namely, 4 very severe, 52 severe, 74 moderate, and 25 mild. The intravenous, intramuscular, and subcutaneous routes were employed in various cases. With the subcutaneous route an average of five injections or 7.50 c.cm. of the vaccine was given, with the intramuscular route four injections or 5.15 c.cm., and with the intravenous route three injections or 1.10 c.cm. The reaction was, as a rule, much more marked after intravenous than after intramuscular injection, but recovery was more rapid. The action of the vaccine was slowest in subcutaneous injection. KHARMA-MARINUCCI (*Ibid.*, July 15th and August 1st, 1920) reports 80 cases of typhoid and paratyphoid fever in children treated by vaccines prepared according to Di Cristina and Caronia's method. Only three deaths occurred, due to pneumonia, intestinal hæmorrhage, and toxæmia respectively. Apart from these three cases the vaccine had a beneficial action on all the patients. The number of injections which were given intramuscularly varied with each case. Sometimes a single injection was sufficient to produce complete defervescence; in others several injections were required. As a rule three to five injections given on alternate days were sufficient. Nineteen cases developed complications—namely, intestinal hæmorrhage (3 cases), pyelocystitis (4 cases), bronchopneumonia (3 cases), pleuropneumonia (1 case), and various suppurative processes (8 cases). The vaccine did not appear to have any preventive or curative action on intestinal hæmorrhage.

167. Influence of Trauma on the Distribution of Psoriasis.

SMALL (*Edin. Med. Journ.*, January, 1921) says that the influence of trauma on the distribution of psoriasis was seen in two distinct groups of cases in the army: (1) Those in which the disease first made its appearance in the neighbourhood of wounds. (A plate illustrating psoriasis around a gunshot wound on the back is shown; the man had had previous attacks of the disease.) (2) Those in which the psoriasis became superimposed on some other cutaneous malady—for example, impetigo, scabies, seborrhoea, etc. In this group the psoriasis adopts the distribution of its predecessor. (A plate shows psoriasis following scabies and impetigo; this man had no previous history of psoriasis.) Small combats the theory that psoriasis and seborrhoea are the same pathological entity by reference to these groups, affirming that psoriasis in a seborrhoeic subject will have its distribution influenced by the pre-existing seborrhoea. He concludes by suggesting that psoriasis is more a general than a local disease, and that its almost constant occurrence on the knees and elbows may be attributed to the greater degree of friction to which these parts are liable.

168. Mantoux's Intradermo Reaction in Infantile Tuberculosis.

SALVETTI (*La Pediatria*, October 15th, 1920), who had previously performed von Pirquet's reaction with human and bovine tuberculin on 600 children, now records the results obtained with Mantoux's intradermo reaction in 500 children, in the great majority of whom human tuberculin only was used. The dose of tuberculin injected was always $\frac{1}{10}$ mg. The results almost entirely agreed with those of the cuti-reaction. A positive reaction was obtained in 131 cases, or 26.20 per cent., and a negative reaction in 369, or 73.80 per cent. Salvetti regards a positive reaction in an infant as possessing a high diagnostic and prognostic value, as it indicates a recent infection which may progress, clear up, or become inactive. A negative intradermo reaction which is normal in the infant diminishes in frequency with advance in age, and it is only in the older child that it possesses considerable diagnostic and prognostic value, for in such cases, especially if repeated, it excludes with relative certainty the possibility of tuberculosis. Salvetti concludes that Mantoux's reaction is the most suitable method for revealing tuberculous infection in infancy.

169. Irradiation of the Hypophysis in Bronchial Asthma.

ASCOLI and FAGIOLI (*Rif. Med.*, July 20th, 1920) have obtained good results in the treatment of asthma by irradiation. They irradiate three different fields—one frontal and two temporal—at a focal distance of 45 cm., using an aluminium filter of 2 mm., S.E. 18-20 cm., ma. 3 $\frac{1}{2}$. The treatment is conducted for twenty-five to thirty minutes at a time, at intervals of a week, about four sittings being necessary. In the five cases of which they give brief notes decided relief and almost complete cessation of the attacks of asthma was noticed. They have also had success from similar treatment in a case of dystrophia adiposis genitalis and one of sclerodermia. On the other hand, no marked good was derived from irradiation in a case of infantilism, one of angioneurotic oedema, and three cases of diabetes mellitus. It is understood that if there is no pituitary gland left, irradiation treatment, given with the object of stimulating the endocrine glands, is not likely to be successful.

170. Serum Treatment of Meningococcal Septicæmia.

KJÆR (*Vgeskrift for Læger*, September 16th, 1920) urges the necessity for early treatment of meningococcal septicæmia by means of large doses of serum given intravenously. The clinical picture being characteristic, it is not always necessary to wait for a bacteriological confirmation of the diagnosis. He records two cases to show that even in desperate and practically hopeless cases early serotherapy may save the patient. Though this treatment was instituted in both cases on the strength of the clinical diagnosis only, a bacteriological examination was subsequently made and meningococci belonging to Type A were found in both the throat and the petechiæ. In one case seven injections were given five into a vein, two into a muscle—on seven successive days. The amounts were 30, 20, 20, 30, 30, 20, and 30 c.cm. respectively. In the second case only two intravenous injections of 30 c.cm. each were given. The author notes that Type A appears to be the most prevalent form of meningococcus in Denmark, constituting about 90 per cent. of all cases.

171. Septic Infections of the Urinary Passages in Children.

JEMMA (*Rif. Med.*, November 6th, 1920), in a clinical lecture on a case of coli bacilluria in a child of 2 years, points out that in a child suffering from irregular intermittent fever, pallor and intestinal disturbances, when other causes have been excluded, one ought to think of coli bacilluria and examine the urine. In the child in question typhoid, paratyphoid, Malta fever, relapsing adenoiditis, syphilis and tubercle were all excluded on clinical grounds, confirmed by negative reactions to the various serum tests, and on examining the urine pus and *B. coli* were found. Too many of these cases are attributed to gastric disturbances, examination of the urine being omitted. The urinary symptoms at this age may only be slight, especially if the kidney is more affected than the bladder. Whether the bacillus enters from without, or from within the blood or lymphatics, is uncertain. If there are no complications the prognosis is good, but sometimes bronchopneumonia or diarrhoea may complicate matters. Treatment by urotropin, helmitol, or salol, and the drinking of plenty of water, give satisfactory results. The urine is usually acid. The author does not mention the treatment by sodium bicarbonate and potassium nitrate. Washing out the bladder is seldom necessary.

172. Osteochondritis Deformans Juvenilis.

ACCORDING to MOUCHET (*Bull. et Mém. Soc. de Chir. de Paris*, December 14th, 1920), this condition, which is called by the Americans Legg's disease and by the Germans Perthes's disease, was previously described in the newborn by the French writers Ménard and Sourdat. It is a relatively rare affection, as Sorel has observed only 6 cases among 1,500 children under his care at the Maritime Hospital at Berek for chronic osteo-articular lesions. Two-thirds of the cases are in boys. The age ranges from 3 to 12 or 13 years, the most frequent age being 5 to 9 years. Unilateral involvement is the rule, the right side being affected as much as the left. As a general rule the limp is only slight, and the movements of the legs are not much restricted. Extension is normal, flexion and external or internal rotation are little if at all affected, but abduction

is constantly limited. X-ray examination, which is all-important in this disease, shows special changes in the head of the femur, the epiphyseal cartilage, and the neck of the femur. The epiphyseal nucleus in the head of the femur is often broken up into two or three nuclei; the epiphyseal cartilage is very irregular, and the neck of the femur shows clear areas below the epiphyseal cartilage. Treatment consists in immobilizing the limb by plaster or continuous extension.

173. Myasthenia Gravis with Osseous Changes.

LÈREBOULLET, IZARD, and MOUZON (*Bull. et Mém. Soc. Méd. des Hôp. de Paris*, December 30th, 1920) record the case of a woman, aged 33, who had suffered from myasthenia gravis for thirteen years, the diagnosis having been confirmed by Goldflam, who was the first to describe the disease. The remarkable features in her case were, first, the slow course of the disease, which allowed her to lead an active life for thirteen years; secondly, the occurrence of changes in the bones of the face; and, lastly, the association of obesity and amenorrhoea. The bony changes consisted of a deformity of the superior maxilla, giving rise to a deviation of the central and lateral incisors, which were projected almost directly forwards and upwards, with wide gaps between each. X-ray examination showed that the lesions were due to well marked decalcification.

SURGERY.

174. Thoracoplasty in the Treatment of Pulmonary Tuberculosis.

BULL (*Il Morgagni*, September 25th, 1920, and *Medical Science*, March, 1920) speaks favourably of excision of the ribs in phthisis. He has operated on 37 cases, divided into two groups of 24 and 13. In the first group there were three deaths and in the second only one. The improvement in the mortality of the second series is attributed by the author to the division of the operation into two stages. In the first stage the fifth to eleventh ribs are removed under local anaesthesia and the further stages of the operation are performed under general anaesthesia. The best results are obtained when 120 to 130 cm. of rib are removed. As a result of his experience Bull recommends removal of the first rib as a routine procedure. After the operation the muscles are sutured with catgut and the skin flaps with silk; a glass drainage tube is kept in for two or three days. Where the cavity remains rigid, fat taken from the abdomen may be used to induce collapse. In 5 out of 9 cases fat so removed constituted a fibro-lipoma around which the local tissues cicatrized regularly. Of the 33 patients who survived the operation 7 have since died of tuberculosis; of these one lived four years and another died of influenzal pneumonia. Of the 25 now living, 11 are cured, that is, have no fever, no bacilli, and no cough, and are able to carry on their regular occupation. The others still present symptoms of phthisis, but show some signs of improvement; it is less than a year since they were operated upon. Unfortunately one cannot guarantee that the lung on the unoperated side will remain free from tubercle.

175. Physiology of Wound Repair.

R. INGEBRIGTSEN (*Norsk Mag. for Laegevidenskaben*, December, 1920) has carried out investigations into the processes of repair of superficial wounds with a view to controlling the researches of Carrel and Lecomte du Nouy. The author's findings, which concern seven series of investigations, are confirmatory and supplementary. Employing the imposing mathematical formulae worked out by du Nouy, he found out that the rate of healing of a wound after it had become sterile conformed to the laws enunciated by du Nouy as far as ordinary surgical treatment was concerned. But when he adopted treatment with compresses soaked in 0.3 per cent. silver nitrate and alternated this treatment with insolation, he found the rate of healing to be far more rapid than with Dakin's solution, which only sterilizes but does not stimulate the tissues. He is not prepared to state which is the more important, silver nitrate or sunlight, but he is so impressed by the value of the combination of the two that this treatment has been adopted at his hospital in every case of superficial injury.

176. Fibrous Osteitis and Inherited Syphilis.

MOUCHET (*Bull. et Mém. Soc. de Chir. de Paris*, December 21st, 1920) has recently observed two cases of fibrous osteitis which were undoubtedly due to inherited syphilis.

One of the patients was a girl of 13 who had had pain in her right foot due to involvement of the astragalus since the age of 4 years. The pain had improved as the result of treatment, but the anatomical condition of the astragalus had not undergone any change. The other case was in a girl, aged 17, who had suffered for some months from pain in the right trochanter. There was slight atrophy of the right lower limb, but the gait and movements of the hip and knee were normal. There was slight tenderness on pressure over the trochanter without any increase in size. X-rays showed the rarefaction and polycystic appearance characteristic of fibrous osteitis. Subsequently the girl slipped on the floor and fractured her femur at the site of the fibrous osteitis.

177. Frequency of Extragenital Chancres.

DELINOTTE (*Rev. de lar., d'otol., et de rhinol.*, November 15th, 1920) devotes his Bordeaux thesis to a study of 192 cases of extragenital chancres which have occurred in various hospitals in Bordeaux during the last thirty years, as compared with 703 cases of genital chancres during the same period. Extragenital chancres are most frequent in men, in whom two-thirds of the cases occur, the favourite age being 20 years. Chancres of the lips are the most frequent, especially of the lower lip. Glass-blowing chancre, according to Delinotte, is less frequent than in former years. Next come chancre of the tonsil, of which a polypoid form has recently been described (vide EPITOME, April 24th, 1920, para. 444), and then, in decreasing order of frequency, chancre of the chin, which is usually due to the barber's razor, and chancre of the female breast, anus, and tongue, where the lesion is usually on the dorsum. Chancres of the limbs, ear, and nose are much rarer. Other very unusual situations for chancres, of which Delinotte records illustrative cases, are the gums, the male breast, and the ocular conjunctiva.

178. Reflex Calculous Anuria.

SALA (*Il Policlinico*, Sez. Prat., November 1st, 1920) reports a fatal case of calculous anuria in a woman, aged 43, who was suddenly seized with a severe pain in the right flank followed by vomiting. A few days later a tender swelling developed in the right lumbo-iliac region. The amount of urine gradually diminished until complete anuria ensued. Gynaecological examination showed atresia of the vagina with infantilism of the external genitals. This condition suggested the possibility of the kidney being a single one as well as being ectopic. Cystoscopy, however, which might have confirmed this, was refused. Exploratory operation showed an ectopic right kidney in the lumbo-iliac position without any torsion of the pedicle or calculus in the renal pelvis. Death took place three days after the operation, and the autopsy showed absence of the uterus, ovaries, and left kidney. There was a small calculus in the right ureter, which did not, however, completely block the lumen, so that the renal secretion must have been diminished and then abolished by a unilateral reflex.

179. Diathermy an Aid in Empyema.

HIRSH (*Med. Record*, December 18th, 1920) quotes a case of long-continued empyema, with osteomyelitis in both fragments of each of the resected ribs, and a great variety of complications requiring a number of major operations, without any good result until diathermy was employed. So great was the improvement that a series of chronic cases with various complications were similarly treated with uniformly satisfactory results, especially in case of haemolytic streptococcus origin, with or without osteomyelitis. Treatment was given daily to the affected region, one electrode being placed directly over the inflamed area, including the incision scars and discharging aperture, and the other over the antero-lateral surface of the chest, both being moved downwards in the course of treatment to take in the areas treated by Carrel's tubes. In the case quoted suppuration gradually ceased and all evidence of rib involvement disappeared, with complete correction of the deformity and improvement in the patient's general condition.

180. Chronic Pyogenic Osteomyelitis.

DE GAETANO (*Rif. Med.*, August 21st, 1920) reports a case of chronic osteomyelitis (forty-three years' duration) of the thigh. The patient, who was 60 years old, was struck on the thigh at the age of 11, but there was no bone injury. The present illness began at 16 years, when the left thigh began to swell in a uniform manner, and after a time pus was discharged. This condition had persisted, but did not interfere much with his work. There was no

history of syphilis or tubercle, and the Wassermann and von Pirquet tests were negative; tubercle bacilli were found. Examination of the pus gave an almost pure culture of *Staphylococcus aureus*. Several sequestra were removed. The most striking feature of the case was the chronicity: it began as a chronic affection without any general illness or any local injury, for the blow at 11 years was a temporary affection, and recovery appeared to follow in the course of a few days.

181. Treatment of Nasal Sinusitis.

ALIKHAN (*Rev. de lar., d'otol., et de rhinol.*, December 15th, 1920) uses the following method of treating retention of purulent secretion in the nasal fossae. The patient is told to empty part of the air in his lungs: his nostrils are then compressed, and he is made to inspire by the nostrils without opening his mouth. Next the doctor counts up to six, and the patient is then allowed to open his mouth, the object of the buccal respiration being to prevent the pus returning into the sinuses when the air is passing into the nostrils. This method has yielded excellent results in acute sinusitis at the stage when lavage is not indicated, and is specially useful in the differential diagnosis of sinusitis from purulent rhinitis.

182. Thrombosis of the Central Artery of the Retina following Ophthalmic Zoster.

AURAND (*Lyon. méd.*, December 10th, 1920) records the case of a woman, aged 75, who forty days after the appearance of ophthalmic zoster on the left side, suddenly lost the sight of her left eye without any preceding strain or injury. Ophthalmoscopic examination showed left optic atrophy and necrosis of the central artery without any retinal haemorrhages. The absence of any cardiac lesion enabled the diagnosis of retinal embolism to be excluded in favour of thrombosis due to endarteritis obliterans, the localization of which was due to the ophthalmic zoster.

OBSTETRICS AND GYNAECOLOGY.

183. Prognosis of Eclampsia.

MARSAUDON (*Journ. de méd. de Bordeaux*, October 25th, 1920), in his Bordeaux thesis, discusses the prognosis of eclampsia from the statistics of the Bordeaux Obstetrical Clinic from 1899 to 1919. The treatment, which consisted in bleeding under oscillometric control, purgation, and administration of chloral per rectum and by mouth, gave as good results as treatment by narcotics or by rapid and systematic emptying of the uterus, as is shown by the following figures: Among 54 cases occurring during pregnancy the maternal mortality was 18.5 per cent. and the foetal mortality 38.5 per cent.; among 16 cases occurring during labour the maternal mortality was 6.2 per cent. and the foetal mortality 18.7 per cent.; among 12 cases occurring in the puerperium the maternal mortality was 8 per cent. and the foetal mortality 25 per cent. Thus, among 82 cases the maternal mortality was 14.6 per cent. and the foetal mortality 32.9 per cent.

184. Intestinal Obstruction and Tubal Pregnancy.

HANAK (*Wien. Klin. Woch.*, November 22nd, 1920) records a case of intestinal obstruction in a woman aged 31 associated with a pregnancy in the right Fallopian tube. The patient had been operated on for tubal pregnancy on the same side three and half years previously, and the intestinal obstruction was found to be due to adhesions between the small intestine and the adnexa on both sides. Complete recovery followed extirpation of the right tube and ovary. The occurrence of ectopic pregnancy on two occasions Hanak attributes to the presence of salpingo-ophoritis, the origin of which could not be determined, as gonorrhoea was denied. Hanak has been unable to discover any previous examples of the association of intestinal obstruction and tubal pregnancy, and has found only five other cases of ectopic pregnancy occurring twice on the same side.

185. Ectopic Pregnancy and Rupture into the Caecum.

CHASE (*Med. Rev.*, December 4th, 1920) describes the case of a patient, aged 25, in whom three months' amenorrhoea was followed during six weeks by painless haemorrhage, and subsequently by vomiting and hypogastric pain, which continued for seventeen days. At this juncture the pain diminished, but a large amount of dark clotted and bright red blood was passed by the rectum. At the time of her admission to hospital, in a state of grave anaemia and collapse, examination was negative

except for a mass the size of a fist in the right side of the pelvis. At operation the caecum was found to be adherent to the posterior surface of a ruptured right tubal gestation; the caecum and the sac communicated by an aperture larger than half a crown, and the foetus, together with much blood clot, lay in the caecum. The rent in the caecum was repaired, the ectopic mass was removed, and a drain was placed in the posterior fornix. The patient recovered.

186. Rupture of Uterus at Caesarean Scar.

KICKHAM (*Boston Med. and Surg. Journ.*, November 18th, 1920) records the case of a 3-para, aged 27, who had undergone two Caesarean sections, and in the thirtieth week of her third pregnancy suffered suddenly from cramp in the lower abdomen and from vomiting, not associated with severe pain. Half an hour afterwards the general condition was good, the pulse was 75, and the temperature normal. The foetus could be palpated with more than usual ease, but the palpability of the uterus was doubtful. Shortly after a discharge of bright red blood had occurred per vaginam laparotomy was undertaken. The peritoneal cavity contained fresh blood, and the dead foetus (still enclosed within intact membranes), as well as the placenta, lay free in the abdomen. Supravaginal hysterectomy was successfully performed. The T-shaped rupture was situated in the anterior wall of the upper part of the uterus, and corresponded generally in position to one of the old scars.

187. Gland Tubules in the Fallopian Tubes.

ARGAUD (*C.R. Soc. Biologie*, October 16th, 1920), who has made observations on several species of mammals, shows that at certain periods tubular glands exist in the tubes near the isthmus. During gestation, for example, the mucous ends-de-sac penetrate deeply into the wall, lengthening and hypertrophying like those in the uterine endometrium. This can be seen well in the gravid bitch. Towards the end of parturition the mucosa of the tube is so occupied with tubules that there is scarcely room for the collagenous connective tissue. After delivery the lining cells of such tubules undergo degeneration. In the human female these glands are much less numerous, but, as in other mammals, they are quite apparent in pregnancy. The observation is of interest because it explains the occurrence of gland tubules found in the Fallopian tubes in certain inflammatory conditions and in some neoplasms.

188. Late Results of Conservative Operations for Myoma Uteri.

SCHMID (*Zentralbl. f. Gynäk.*, October 30th, 1920) records the sequelae of 54 cases of conservative operation (enucleation or myomectomy) for myoma uteri. Recurrence was found in 9 patients, 6 of whom, however, did not present symptoms. Among 10 patients there had been fifteen subsequent pregnancies, of which ten continued to term. Among 43 cases four patients reported increased menstrual loss (these four were approaching the climacteric), eleven had menstruation of unaltered character, and twenty-eight (or 65 per cent.) exhibited diminished duration and extent of menstruation.

189. Five-Year-Old Foetus Loose in the Abdominal Cavity.

SCHAANNING (*Norsk Mag. for Lægevidenskaben*, November, 1920) records the case of a married woman who consulted a doctor for varicose eczema of the legs. Quite incidentally she gave the following history. She had undergone a normal confinement at the age of 27. Since then she had never aborted. In December, 1908, at the age of 44, she ceased to menstruate and soon exhibited definite signs of pregnancy. This was marked by several attacks of abdominal pain. After pregnancy had lasted about nine months labour pains set in and were followed by a slight haemorrhage, which lasted about a couple of days. After about twelve months' amenorrhoea, normal menstruation returned, recurring regularly at four-week intervals. On examination five years later, the author found a large, nodular, freely movable tumour in the abdomen. Another tumour, almost as large as an infant's head, could be felt in the right lower abdomen. Laparotomy was performed, and a foetus, weighing 1,250 grams, was found perfectly free in the peritoneal cavity. Filling the pouch of Douglas was a white, smooth tumour, adherent to the lower part of the gut. This tumour was also removed, together with a haematosalpinx on the right side. Uneventful recovery followed. The large tumour proved to be packed with brown, soft material, consisting of organized blood or placental tissue. As the 7 to 8 cm. long cord, projecting from the umbilicus, lay outside the membranes in which

the foetus was wrapped, the author suggests that they were not, as he thought at first, the original foetal membranes, but the result of a deposit of peritoneal fluid about the foetus after its escape from a ruptured tube. There was no free fluid in the peritoneal cavity.

190. Statistics of Fibroid Operations.

PESTALOZZA (*Il Policlinico*, Sez. Prat., November 22nd, 1920) gives the following statistics of fibroids on which he had operated during the last ten years. In 120 cases myomectomy alone was performed, and in these cases the superiority of surgical treatment over radiotherapy appeared to be indisputable. In 45 of these cases it was possible to cover the wound with the serous coat taken from the vesico-uterine fold, as in Pestalozza's method of pelvic hysterectomy. The total mortality was 2.4 per cent. In 16 cases fibroids were associated with cancer; in some instances there were ovarian tumours. Necrosis was present in 32 cases. Eight cases occurred in pregnancy; sixteen showed cavity formation; nineteen were of enormous size.

191. Treatment of Septic Abortion.

OF A series of 200 cases of septic abortion treated by HILLIS (*Surg., Gyn., and Obstet.*, December, 1920) half received no local treatment, and half were curetted; the former group had fewer days of fever, fewer complications, a shorter stay in hospital, and a lower mortality. It is concluded that cases of septic abortion should—excepting those in which haemorrhage threatens life—receive no local treatment until they have been for at least five days free from fever. On the other hand, it is advisable at the end of this period to curette cases which have become afebrile; this operation prevents subsequent bleeding and shortens the stay in hospital. Of 122 cases of non-septic abortion, no fewer than 32 per cent. were deliberately induced.

192. Pelvic Kidney Mistaken for Haematometra.

PETERSON (*Amer. Journ. of Obstet. and Gyn.*, November, 1920), in an article dealing with errors in gynaecological diagnosis, describes the case of a girl, aged 17, who had never menstruated, but had recently suffered from periodic attacks of malaise and lower abdominal discomfort. Rectal examination failed to reveal with distinctness either uterus or appendages, but a globular mass could be felt at the end of the examining finger. In the absence of a vagina this mass was taken to be a haematometra. At operation, after dissection upwards for three inches of the tissue between the rectum and bladder, a scalpel plunged into the mass called forth an alarming haemorrhage, which could only be stopped by a tight gauze pack. There was much subsequent haematuria. Peterson alludes to similar cases reported by Cullen and Engstrom, and to an instance in which a girl of 21 died from uraemia seven days after removal of a pelvic tumour which, in the absence of a vagina, had been originally diagnosed as a haematometra (Buss).

PATHOLOGY.

193. The Anaerobic Flora in Intestinal Diseases.

ACCORDING to CAPONE (*Lo Sperimentale*, Fasc. i-iii, 1920), who has made a study of the anaerobic flora in certain morbid conditions of the intestine—namely, bacillary dysentery, entero-colitis of uncertain etiology, and typhoid fever—there is a great diminution and often a complete disappearance of the anaerobic putrefactive intestinal organisms in these conditions. He considers that some species of anaerobes which have been isolated exclusively from cases of intestinal disease cannot be regarded with certainty as the pathogenic agents of some of the diseases studied.

194. Xanthochromia.

LEIVISON (*Arch. Int. Med.*, October 15th, 1920) reports three cases in which the spinal fluid obtained by lumbar puncture was of a bright yellow colour, and discusses the significance of this condition. Xanthochromia has been found in such a variety of spinal conditions that no etiological factor would seem to be common to all. It has been observed in neoplasms of the cord and its membranes, gumma of the meninges, adhesions between the membranes, vertebral tumours and fractures, tuberculous meningitis and spondylitis, spinal gliosis with syringomyelia, multiple sclerosis, pachymeningitis, and several other conditions. The yellow fluid by itself is perhaps not of much importance, but when in association with the

colour there is an increased coagulability of the fluid, then there is practically always some obstructive lesion of the spinal canal. The obstruction to the flow of the cerebro-spinal fluid allows of the formation of a pocket in which the fluid stagnates, and into which various elements pass by transudation from the vessels within its walls. It is sometimes possible to obtain haemoglobin reactions in certain cases of xanthochromia, and it has been suggested that there are minute haemorrhages into the spinal canal and ventricular spaces to account for the yellow coloration, and it may be that decomposition of the haemoglobin has proceeded so far in the other cases that one fails to discover traces of it. It must be admitted, however, that the occurrence of yellow spinal fluids is not yet satisfactorily explained.

195. Wildbolz's Auto-urine Reaction in Tuberculosis.

GRAMÉN (*Hygiea*, November 16th, 1920) has tested Wildbolz's reaction in about 50 cases of latent or active tuberculosis and in a certain number of healthy "controls." When the disease was definitely active the reaction was unmistakably positive, as shown by the formation of a small circumscribed swelling in the skin at the point where one to two drops of the patient's urine, reduced to one-tenth of its original volume by evaporation *in vacuo*, had been introduced by intracutaneous injection. In another class of case, in which the clinical signs pointed to more or less complete arrest of the disease, the reaction was either negative or faintly positive. Thus there would appear to be some justification for the claim, made by Wildbolz, that the auto-urine reaction distinguishes between active and latent disease, and is therefore superior to von Pirquet's tuberculin test, which only indicates presence or absence of infection without discriminating between infection and active disease. A disconcerting finding in some of Gramén's cases was a positive reaction, although the person concerned was either a "control" or a patient whose tuberculosis was, on the clinical evidence, arrested. But the author attaches such importance to the reaction that when it and the clinical evidence disagree, he is inclined to suspect the reliability of the latter. He experienced little difficulty in deciding whether a reaction was positive or negative, but he found at first some difficulties in the technique, for it was not easy to deposit the urine at the precise level of the skin where it would neither be too superficial and produce necrosis, nor too deep and thus fail of its object—hence the finding that of two simultaneous intracutaneous injections in the same person, one might be negative and the other positive. It is therefore advisable to give at least three injections simultaneously in different parts of the skin.

196. A Modification of Dargallo's Stain for Elastic Fibres.

DARGALLO (*Rev. Españ. de Med. y Cir.*, November, 1920) describes a modification of his stain for elastic fibres; the period of staining is thereby reduced from eight hours to fifteen to twenty minutes. A rather thick film of sputum is subjected to the action of nitric acid (1 in 3) for five minutes; without subsequent washing the stain is added, consisting in fuchsin (Ziehl) 3 parts, ordinary alcohol 2 parts, and saturated solution of ferric chloride 1 part. (The stain must be freshly prepared.) Washing is performed in running water, and may be supplemented, in the case of very thick films, by addition of ordinary alcohol or (momentarily) of nitric acid, 1 in 3.

197. Determination of Blood Volume.

HARRIS (*Brit. Journ. of Exp. Path.*, June, 1920), from an investigation of the vital red method of estimating the total volume of blood in the body, is of opinion that the values given are too high. In this method a known quantity of the dye is injected into the blood stream, and a definite amount of blood is withdrawn after a few minutes. By comparing serum dilutions of known strength before and afterwards the concentration of the dye in the sample can be determined. Harris states that the dye leaves the blood vessels even before it has spread uniformly through the circulating blood. The best interval for withdrawal of the test sample would seem to be from two to two and a half minutes after injection of the dye. The author, by using a control method which consists in the removal of the maximum amount of haemoglobin compatible with life whilst keeping the blood volume constant by the simultaneous injection of gum saline, suggests that a correction coefficient will give more accurate estimations in the case of the vital red values. This coefficient in man will lie between 0.8 and 0.9. Congo red, however, gives truer values, the correction coefficient in this case being 0.9 for four-minute samples.

EPITOME OF CURRENT MEDICAL LITERATURE.

MEDICINE.

198. Mechanism of Shock and Exhaustion.

CRILE (*Journ. Amer. Med. Assn.*, January 15th, 1920) says that the man in acute shock or exhaustion is able to see danger, but lacks the normal muscular power to escape from it; his temperature may be subnormal, but he lacks the normal power to create heat; he understands words, but lacks the normal power of response. In other words, he is unable to transform potential into kinetic energy in the form of heat, motion, and mental action, despite the fact that his vital organs are anatomically intact. His mental power fades to unconsciousness; his ability to create body heat is diminished until he approaches the state of the cold-blooded animal; the weakness of the voluntary muscles finally approaches that of sleep or anaesthesia; the blood pressure falls to zero; most of the organs and tissues of the body lose their function. It is evident, therefore, that in exhaustion the organism has lost its self-mastery. Self-mastery is achieved only by the normal action of the master tissue—the brain. This subject is gone into at some length by Crile, and he concludes finally that the brain is an organ of intense metabolism. The brain cells may be conceived as having their protective and nutritive cytoplasm evolved to function at a distance. The energy-transforming function of the brain has such high selective value in the biologic sense as to confer a selective value also on the structure and function of the liver and of the blood; for if the brain cells thus stripped cannot transform energy fast enough to drive the muscles speedily enough to escape from the enemy, then the liver and the blood will perish as well as the brain. The more completely the liver and the blood and the lungs and the kidneys keep the brain cells free from the impaling by-products of their active metabolism, the clearer pair of heels will the pursuing enemy see. The brain cannot work continuously, but a reversible process is necessary at regular intervals to restore it. This process in the higher centres is called sleep. The more intense the activation, the more needed is sleep. The brain is the only organ that sleeps conspicuously. Of great significance is the fact that the entire man spends one-third of his time waiting for the brain to rest re- itself—to put itself again in the position of being able adaptively to transform potential into kinetic energy.

199. Ambulatory Treatment of Varicose Ulcers.

LANDE (*Journ. de méd.*, December 25th, 1920) describes a method for the ambulatory treatment of varicose ulcers. First the periphery of the ulcer, then the ulcer itself, is cleansed with tampons soaked in ether, this cleansing being a little painful. Next the ulcer and surrounding parts are covered with a thick layer of Vienna cream—that is, oil of sweet almonds 140 grams, aq. calcis, zinc oxide, of each 60 grams, sodium bicarbonate 40 grams. The part is then covered with two or three layers of sterile gauze, and over all moist starch muslin bandages. It is essential not to put these on too tight, and that the entire skin be carefully covered. On the instep and at the level of the tendo Achillis a small pad of wadding is necessary to prevent the skin from chafing. The dressing should be put on in the morning after a night's rest, and can be left on for five or six days, at the end of which time it has to be renewed. Complete healing, even in large ulcers, will be obtained after a period varying from six weeks to three months.

200. Lethargic Encephalitis in Children.

PIPING (*Vineta Läkarsällskapet. Handlingar*, November-December, 1920) has observed a small epidemic of lethargic encephalitis among children 6 to 14 years old. Between November 25th and December 9th he treated three cases in hospital and two others in a polyclinic. The most prominent symptoms were mental disturbances, headache, diplopia, fever, twitching of certain muscle groups, and insomnia which was succeeded by profound drowsiness lasting several days. The two polyclinic cases were comparatively mild, but in these, too, there was headache with fever, diplopia, restlessness, and insomnia succeeded by drowsiness. The muscular twitchings in one of the cases admitted to hospital were suggestive of severe chorea; the girl was maniacal and suffered from hallucina-

tions. The course of infection could not be traced in any of these cases, had occurred sporadically, and in none was there a history of symptoms indicative of influenza. It would seem that only a small minority of the community is susceptible to this disease, for it does not break out wholesale in institutions or affect more than one member of a family. Thus, in no case did other members of the families of these patients develop the disease, and in the children's home, from which one of the patients came, there were no similar cases.

201. Treatment of Persistent Hiccough.

KENRIGS (*New England Medical Journal*, January 15th, 1921) records two cases of persistent hiccough in which, after other methods had failed, success was obtained by a gentle vertical pressure for some minutes on the cricoid cartilage. One of the patients had recently had an attack of influenza in Paris and the other had lost consciousness for three days four months previously. The condition of persistent hiccough, which is regarded by some observers as a mild form of lethargic encephalitis, has been attributed to a toxic irritation of the phrenic nerve.

202. Streptococcal Serum in Pyaemia.

HANSEN (*Ugeskrift for Læger*, January 6th, 1921) has treated six cases of pyaemia with subcutaneous injections of polyvalent streptococcal serum, and the beneficial results observed in every case were not marred by any complications traceable to the serum. He gives details of all his cases; in the first four the prognosis was very bad, and the prompt response to the injections was, therefore, the more striking. In the remaining cases the beneficial action of the serum was marked by the speed with which local septic processes cleared up—a speed three to four times greater than could be anticipated without specific treatment.

203. The Normal Regurgitation of Duodenal Fluid into the Stomach.

ACCORDING to JARNO (*Zeitschr. f. Physiol.*, October 7th, 1920) the borborygmi which occur in the majority of hungry persons correspond to the periodic empty condition of the gastrointestinal canal, as is shown by the following observations: (1) During the occurrence of borborygmi the human stomach is practically always empty, and as soon as the borborygmi cease, the stomach contains as a rule a secretion of hydrochloric acid; (2) borborygmi occur periodically just as does the empty condition of the stomach; (3) in cases of gastro-succorrhoic borborygmi are absent, as the constant presence of acid in the stomach prevents the organ being empty. Jarno has observed in healthy persons, in whom he has passed a tube into the stomach fifteen to twenty minutes after cessation of borborygmi, that in most cases the secretion obtained is coloured yellowish-green owing to admixture with bile, and usually also contains more or less free hydrochloric acid. If the same individual is examined next day an hour after the borborygmi, either a secretion free from bile is obtained or else no secretion at all. The presence of bile pigment is the best indication of the presence of duodenal fluid. The purpose of the regurgitation of the duodenal fluid into the stomach is probably to neutralize or at least to diminish the acidity in the stomach.

204. Motor Disturbances of the Stomach and Resection of the Vagus.

BORCHER (*Zentralbl. f. Chir.*, December 18th, 1920), as the result of experiments on cats and rabbits, came to the conclusion that the vagus nerve can hardly be regarded as the motor nerve of the stomach. Gastric peristalsis after bilateral section of the vagi was in no way different from the normal. Gastric motility after complete transverse section at different levels took place in the normal way, and the function of the pylorus was not essentially affected. As regards the reaction of the gastric musculature to electrical stimulation of the vagi in the neck, Borchner never succeeded by this means in producing peristalsis or increasing movement already present. Lastly, both pilocarpin and atropine had quite as much effect on the motility of the stomach when the vagi were intact as when they were divided.

205. Pernicious Anaemia in Childhood.

ACCORDING to MENSI (*La Pediatria*, September 1st, 1920), pernicious anaemia is one of the rarest of children's diseases, only four cases (whose ages ranged from 7 months to 7 years) having been observed among 3,029 children under the author's care in a children's hospital. Of 29 cases in children whose ages and sexes are recorded, 14 were under 2 years and 15 above 2 years; 20 were males and 9 females. Apart from syphilis, tuberculosis, and the bothrioccephalus, in the great majority of cases it is impossible to find any causal factor. There is a plastic form, which is by far the commonest, as well as an aplastic form; intermediate or hypoplastic forms have also been described. The prognosis is most unfavourable: of 20 cases 16 died, in 3 the issue was not recorded, and 1 (Mensi's fourth case) was still alive at the time of writing. Treatment appears almost valueless.

206. Calomel Injections in an Aqueous Excipient.

A GOOD deal of pain sometimes follows calomel injections when given in oily emulsions; with a view to avoiding this PORCELLI (*Riv. Osped.*, November 30th, 1920) has been using an aqueous solution prepared by Professor Mazza and containing no gum arabic. The preparation gives a perfect emulsion with a light shaking and without boiling. Low temperatures do not materially affect the fluidity of the excipient. Under the microscope the emulsion is seen to be made up of very minute shining crystals of a globular or dumb-bell shape, uniformly distributed and without any tendency to form clumps. After some preliminary trials on animals, the author used it clinically in men and women, with good results. In 78 per cent. of the cases there was no pain at all; in 14 per cent. very slight and temporary pain came on twelve to twenty-four hours after injection; in 8 per cent. the pain was more marked, but always bearable. No abscess formation occurred. The therapeutic effects were excellent.

207. Treatment of Intermittent Claudication by Diathermy.

GRÜNBAUM (*Wien. Klin. Woch.*, October 21st, 1920), who had previously described the treatment of chilblains by diathermy (see EPITOME, March 6th, 1920, No. 245), now reports eight cases of intermittent claudication successfully treated by this method. Six were in men and two in women, aged from 41 to 56. Of the men four were heavy smokers, one a slight smoker, and one a non-smoker. Of the two women one was a heavy cigarette smoker, and the other a very moderate smoker. Syphilis was denied in all cases. In seven cases the condition was bilateral, and in one unilateral. Treatment by diathermy, which was continued for four to eight weeks, was very satisfactory. Improvement of the subjective symptoms occurred in all, and in some cases the patient was enabled to walk long distances without interruption and free from pain. Each sitting lasted ten to twenty minutes, the strength of the current varying between 400 and 800 milliamperes.

208. Radium Therapy of Acromegaly.

BERTOLOTTI (*Giorn. d. R. Acad. di Med. di Torino*, March-June, 1920) records the following case: A man, aged 35, was admitted to hospital with all the signs of a rapid and malignant attack of acromegaly—namely, almost complete blindness, profound adynamia, sexual impotence, and advanced cachexia. X-rays showed a tumour of the hypophysis, the size of a small nut, compressing the optic chiasma. The patient was then subjected to radium treatment, amounting in all to 7,360 mg., distributed over eight sittings during a course of four months. The irradiation was carried out exclusively over the skin of both temporal regions. Bertolotti refrained from using the intranasal route through fear of producing too violent a reaction. The result of treatment was as follows: During the first stage, which lasted from February 8th to March 13th, 1918, there was an aggravation of all the symptoms, especially as regards vision; in the second period (March 13th to July) there was slow but progressive improvement; and in the third period a complete clinical cure was effected.

209. Treatment of Pulmonary Tuberculosis by Artificial Pneumothorax.

GRABIOLO and FOSSATI (*Rev. Sud-Amer. de Endocrin.*, September 15th, 1920) record seventeen cases of pulmonary tuberculosis treated by artificial pneumothorax. Almost all the patients had evidence of cavities, and the majority had unilateral lesions only when the treatment was commenced. The result was excellent in eight patients, good in two, two died, and seven gave up the treatment after four to twelve months' trial.

SURGERY.**210. End-Results of the Operative Treatment of Duodenal Ulcer.**

FINSTERER (*Wien. Klin. Woch.*, January 13th, 1921) has operated on 203 cases of duodenal ulcer, 27 of which occurred up to 1914, and 176 since. Up to 1914 he performed gastro-enterostomy only followed by ligature of the pylorus, but since 1915 he has almost exclusively performed resection of the duodenum and of at least half the stomach, or resection of half the stomach with exclusion of the duodenum. In 118 resections of the duodenum and stomach his mortality was 5 per cent. In the last two years, owing to increasing experience, the mortality in 21 resections had fallen to 1.4 per cent. Resection, therefore, was not so dangerous as gastro-enterostomy, in which the mortality ranged from 2 to 11 per cent. Finsterer's end-results after resection of the duodenum and after resection of the stomach had been hitherto very good. The patients felt perfectly well, had increased in weight up to 30 kilos, and had a complete absence of pyrosis—notwithstanding, in some cases, occasional alcoholic excess—although no special diet was observed. Of 63 cases of resection of the duodenum and half the stomach, which had been operated on longer than one to five years, 59, or 93 per cent., were absolutely free from symptoms, and 3 cases had occasional symptoms which were not connected with the stomach, as they could digest any food. The end-results were also good in cases of resection of the prepyloric part of the stomach, leaving behind the pylorus and the ulcer. Of 8 cases operated on longer than three to five years, 7 were absolutely free from symptoms, and of 15 which had been operated on longer than from one to three years, 13 were free from symptoms.

211. Aneurysm of the Hepatic Artery.

JONSSON (*Hospitalstidende*, December 29th, 1920) reviews the literature of this subject and contributes a new case, that of a sailor, aged 27, who had recently contracted influenza twice, once with pneumonia. The symptoms were typical: sudden violent pain in the epigastrium with haematemesis. He was operated on, and the gall bladder, which was distended with clotted blood, was firmly plugged. But the aneurysm was not detected and the hepatic artery was not ligatured. The haemorrhages recurred at irregular intervals, and he died eighteen days after the operation. At the necropsy an aneurysm of a branch of the hepatic artery was found in the liver, at a depth of about 4 cm. from the surface. Apparently only seven other cases of intrahepatic aneurysm have been recorded. Extrahepatic aneurysm of the hepatic artery is, however, much more common. Villandre in 1912 collected thirty-nine cases, thirty-five of which were extrahepatic. The condition is almost invariably fatal, and only one case has been recorded (Kehr's) in which the correct diagnosis was made before operation. Bode in 1909 published a case treated by ligature of the gastroduodenal artery and several of its branches. Necrosis of the liver is the complication which surgeons dread as a sequel to ligature of the hepatic artery; but, in view of the hopelessness of the prognosis in the absence of heroic measures, the author thinks that the risk of hepatic necrosis should be taken. Provided adhesions have formed about the liver, there is a possibility that they might provide an adequate collateral circulation in the liver after ligature of the hepatic artery.

212. Syphilitic Disease of the Cervical Vertebrae.

WINNER (*Ugeskrift for Læger*, November 25th, 1920) discusses the diagnosis of this condition, and points out that it usually occurs decades after infection. As it is very rare compared with tuberculous caries, the diagnosis should not be made without strong evidence. In doubtful cases the effect of anti-syphilitic treatment is of great value in the differential diagnosis. The X-rays, on the other hand, seldom distinguish between the two conditions, although they may be of great value in the recognition of subacute or chronic arthritis of the vertebral column. Without specific treatment syphilitic spondylitis often terminates fatally by more or less sudden compression of the medulla, haemorrhage into the cord, or dislocation or fracture of the affected vertebrae. The case on which the author's paper is based was that of a man, aged 60, who had contracted syphilis twenty-two years earlier. He had been given forty injections of mercury soon after infection, and there had since been no eruption. No further anti-syphilitic treatment was given. In spite of Wassermann's reaction being negative in the serum and cerebro-spinal fluid, and the cerebro-spinal fluid being normal in

other respects, a "probable diagnosis" of syphilis was made, and was confirmed by the success achieved by injections of mercury and neo-salvarsan.

213. Tuberculosis of the Larynx Cured by Galvano-cauterization.

BLOCH *P. v. de lary. d'isol. et de rhin.*, November 30th, 1920) records a case in a girl, aged 17, suffering from isolated and clinically primary tuberculosis of the larynx, resembling a tumour. Complete recovery took place in six to eight months as the result of galvano-cauterization. In this rare form of tuberculosis, which was first described by Avellis, the part of the larynx most frequently affected is the ventricle, while, at the onset at least, the rest of the larynx escapes. The lesion consists of a rounded, sessile mass, the evolution of which is slow and painless. The patient is generally young, and there are no obvious signs of pulmonary tuberculosis. Removal is usually followed by a permanent cure, although sometimes active pulmonary tuberculosis or generalized milary tuberculosis may develop.

214. The End-Result of Pneumatosis Cystoides.

NEULÖSTER (*Zentralbl. f. Chir.*, December 4th, 1920) records the case of a man, aged 30, suffering from severe abdominal pain and vomiting. Laparotomy showed the presence of numerous gas cysts on the great omentum, and on the serous coat of the small intestine. The pylorus was transformed into a tumour almost the size of a walnut, which was adherent to the porta hepatis, and was causing a tight stenosis of the pylorus. A large number, but by no means all, of the cysts were removed, and posterior gastro-enterostomy was performed. Considerable improvement followed the operation, and when laparotomy was performed again eleven and a half years later, owing to return of gastric trouble, all the gas cysts had completely disappeared, and no adhesions had developed.

215. Universal Light Baths in Diseases of the Eyes.

LUND-GAARD (*Hospitalstidende*, December 29th, 1920) has for several years watched the effect of universal exposures of the body, as distinct from strictly local treatment, on various diseases of the eyes, at the Finsen Institute in Copenhagen. He used as a rule the carbon arc lamp, and his exposures lasted fifteen to thirty minutes at first, being increased to two to two and a half hours at a later stage. After reviewing recent publications which claim almost marvellous results, the author deals seriatim with the following groups of cases. Phlyctenular kerato-conjunctivitis: no definite improvement. Tuberculous keratitis (31 cases): found unsuitable for this treatment. Scleritis (8 cases): results variable. Diseases of the lacrimal passages (58 cases): results negative in most cases, but in 2 cases, after free opening and curetting, the tuberculous lesions cleared up with remarkable speed under universal light treatment. Chronic iritis and iridocyclitis (10 tuberculous cases): results good in 5 cases; in 2 cases the results were doubtful, and in 3 negative. Only in this class of case is the author inclined to indulge in qualified praise of the treatment. At an early stage of treatment there was increased local injection, suggesting a sort of focal tuberculin reaction. As the treatment by universal light baths requires to be prolonged, the author feels more inclined to adopt local light treatment, supplemented by tuberculin.

OBSTETRICS AND GYNAECOLOGY.

216. Intestinal Obstruction after Ventrofixation of the Uterus.

HASTROP (*Ugeskrift for Læger*, December 30th, 1920) considers the risk of intestinal obstruction from fixation of the uterus to the anterior abdominal wall so great that this complication alone is enough to condemn this operation as unjustifiable. The Alexander-Adams operation for prolapse of the uterus having been found also to give satisfactory results in uncomplicated cases, there is the less need for an operation which entails grave risks of fatal intestinal obstruction. None of the various modifications of the original operation for ventrofixation seems to have eliminated the risks of this complication, which are probably enhanced when the union between the uterus and the abdominal wall is dragged out into a thin fibrous band by the weight of the uterus. But even before the formation of this band the intestine may become incarcerated between the uterus and the abdominal wall, and the author records a case in which acute intestinal obstruction

occurred fifteen days after he had performed Olshausen's operation for ventrofixation. Fortunately the patient had not left hospital, and the cause of her vomiting and abdominal pain being correctly diagnosed, she was operated on early, and the obstruction was removed before the intestine had become permanently injured. The intestine was found to have slipped down through the slit between the fundus of the uterus and the anterior abdominal wall, although, at the time of the ventrofixation, care had been taken to include the upper portion of the uterus in the peritoneal suture. After removal of the two catgut sutures and closure of the abdominal wound, the patient made a remarkably good recovery. This case and the study of the literature have convinced the author that ventrofixation of the uterus is an operation to be altogether discarded.

217. Premature Separation of the Normally Implanted Placenta.

According to VAN DER FAK (*Nederl. Tijdschr. v. Geneesk.*, January 18, 1921, 1921) records a fatal case in a 5-para, aged 38, premature separation of the normally implanted placenta at the end of pregnancy is a rare condition, only ten examples of the kind having been found by Guedel among 155 cases of separation of the placenta. The prognosis is very unfavourable both for mother and child, being much worse than in marginal separation, of which the diagnosis is much easier. The treatment, which consists in immediate emptying of the uterus, can often save the mother, but the child very often dies. Among 106 cases collected by Guedel only 6 children and 54 mothers survived.

218. The Physiological Anæmia of Pregnancy.

GRAM (*Ugeskrift for Læger*, December 23rd, 1920) has compared the blood of forty healthy adult women (chiefly nurses) with that of fifty-nine women in the last seven months of pregnancy, and has found a considerable difference in the percentage of hæmoglobin in the two classes. The blood was taken by aspiration of a vein, and stabilized by the addition of an isotonic solution of 3 per cent. sodium citrate. He calculates that the percentage of hæmoglobin in the blood always varies proportionately with the volume of the blood cells, the ratio of the two being: hæmoglobin per cent. = volume per cent. \times 2.1. Among non-pregnant women the average volume per cent. was 40 (hæmoglobin 84 per cent.), while among pregnant women there were only ten with a volume per cent. of 40 to 43. In 31 cases there was a volume per cent. of 36 to 39. In 18 cases the volume per cent. was less than 36. Classifying his cases according to the stage of the pregnancy, the author found that the anæmia culminated in the fifth month of pregnancy.

219. Three Spontaneous Deliveries after Caesarean Section.

GROSSE (*Gynéc. et Obstétr.*, 1920, ii, 2) records the case of a woman who underwent spontaneous delivery at term in three successive pregnancies, which followed Caesarean section practised in 1908 for dystocia due to ovarian cyst. The operation was performed forty-two hours after rupture of the membranes, thirty hours after the onset of "pains," and after the failure of several attempts (made in the patient's home) to effect instrumental delivery. Linen sutures were used; several months after operation stitches were discharged from an abscess in the region of the scar.

220. Posterior Colpotomy for Puerperal Peritonitis.

At the New York Academy of Medicine (*Med. Record*, November 6th, 1920) SCHWARTZ, while advocating conservative treatment of puerperal sepsis, said that operative intervention would help to save life in certain cases characterized by asthenia, with ascending tenderness and pain, and by leucocytosis with increase of polymorphs. He had treated eight such cases by transverse incision of the vaginal mucous membrane, making gentle palpation with the fingers in the peritoneal cavity, but not breaking up adhesions. This was done with the patient in bed, and after the incision had been enlarged with two fingers to give exit to any accumulation of pus that might be found, three gauze drains were introduced and left for seven days.

221. Treatment of Menorrhagia.

For severe uterine bleeding, which, in the absence of sub-involution, myoma, or other innocent or malignant uterine neoplasm, may be regarded as due to asthenia of the uterine muscle, consequent on alterations in the autonomic or sympathetic nervous elements, which the author

prefers to call "metrasthenia," MANSFELD (*Zentralbl. f. Gynäk.*, October 30th, 1920) has employed treatment by adrenalin chloride. With the object of improving the uterine tone, Mansfeld treated 25 cases by one or more injections of adrenalin chloride into the portio cervicalis; good results were obtained in 21. Of 26 cases treated by application of the solution to the cervix, 22 gave successful results. In other cases Mansfeld employs unilateral castration by X-rays.

PATHOLOGY.

222. The Islands of Langerhans in Diabetes.

DUBREUIL and ANDERODIAS (*C. R. Soc. Biologie*, November 27th, 1920) record a single observation which seems to shed some light on the part played by the islands of Langerhans in diabetes. They had a patient, aged 32, who at her first confinement gave birth to a very large stillborn child; the pregnancy had been accompanied by albuminuria and eclamptic attacks. The second pregnancy was normal. In the eighth month of the third pregnancy sugar appeared in the urine to the extent of 60 grams to the litre; a very large macerated foetus was expelled at term and the sugar disappeared from the urine a few days later. The fourth pregnancy was uneventful up to the eighth month, but as the urine showed 50 grams of sugar to the litre labour was induced at the beginning of the ninth month and a very large foetus, which lived only for a few minutes, was removed. The amniotic fluid did not contain sugar, and it disappeared from the urine after seven days. *Post-mortem* examination of the foetus revealed a liver more than three times the weight of the normal organ at that period. The other organs were large but apparently normal. Of the portions preserved for examination without any preconceived line of research, only the pancreas revealed histological abnormalities. Even with a low power the enormous size of the islands of Langerhans was a striking feature, though in the normal foetus it requires some search to find them. The islands appeared as very large compact epithelial cell masses, which by calculation were on the average twenty to thirty times the size of the normal islands. Whatever be the mechanism, the general function of the islands of Langerhans is to regulate the sugar content of the blood; they maintain at a fixed titre the normal glycaemia. In this case the glycosuric mother supplied to the placenta blood highly charged with sugar; in all probability the foetal blood also obtained a superabundance of sugar. This excess of carbohydrate accounted for the excessive weight of the foetus, but it was necessary for the foetus to keep on destroying the excess of blood sugar, and such a function fell on the islands of Langerhans. Hence there was a hypertrophy of these structures and an outpouring of glycolytic ferment from them. The research, though very incomplete, as the authors admit, is suggestive.

223. The Cerebro-spinal Fluid in Early Syphilis.

SCHOU (*Hospitaltidende*, November 3rd, 1920) has made about 1,200 examinations of the cerebro-spinal fluid at the Rigshospital in Copenhagen in about 800 cases of syphilis of less than three years' standing. In addition to Wassermann's reaction, the cerebro-spinal fluid was examined for cells and proteins. The cases were classified according as they had or had not been given specific treatment. In 491 cases of recent untreated syphilis morbid changes in the cerebro spinal fluid were found in the following proportions: In 12 per cent. of 56 cases of primary syphilis in which Wassermann's reaction in the blood was positive; in 12 per cent. of 75 cases of primary syphilis with a negative Wassermann reaction in the blood; in 23 per cent. of 300 cases of secondary syphilis; in 39 per cent. of 41 cases of syphilis of six to twelve months' duration; and in 27 per cent. of 15 cases of syphilis of one to two years' duration. Commenting on these findings, the author notes that his positive results were few compared with those of many other investigators, with whose observations his own disagreed on another point—he found most of the morbid changes in the cerebro-spinal fluid in the second half-year of infection. Most of the morbid changes in the cerebro-spinal fluid were represented by pleocytosis; next in frequency was globulinose (25 per cent.), then albuminose (14 per cent.), and finally a positive Wassermann (21 per cent.). The number of cells was usually within the limits of 10 to 50 per c.c.m., and the three highest readings were 257, 717, and 2,500 cells. The figures for the protein content showed wide variations, probably traceable to faulty

technique, and the author concludes that Bisgaard's test is unsatisfactory in estimating the amount of small quantities of albumin.

224. The Etiology of Goitre.

BOITEL (*Rev. méd. Suisse rom.*, November, 1920) discusses the etiology of goitre in a paper based on the study of 1,308 cases of goitre which had attended Roux's clinic at Lausanne from 1887 to 1917. His conclusions are as follows: (1) Goitre is very unevenly distributed throughout the Canton of Vaud. (2) This distribution seems to correspond with the physical geography of the region; its minimum incidence occurs in the Jura chain of mountains, especially on the eastern slope, and its maximum incidence in the Broye and Mentue valleys. The plain of the Rhône is also more affected than the neighbouring mountains. (3) Hereditary influence was demonstrated in 47 per cent. of the cases. (4) It could not be proved that the native population was more or less affected than newcomers. (5) Goitre had an entirely different distribution from that of typhoid fever. (6) Goitre appears to attack the rural population a little more than the dwellers in towns, but the difference is not very pronounced. (7) There is no evidence that as claimed by Hunziker—the primary cause of goitre is absence of iodine in the district.

225. The Corpus Callosum in Chronic Alcoholism.

LAIGNEL-LAVASTINE (*Bull. et Mém. Soc. Méd. des Hôp. de Paris*, December 2nd, 1920), from examination of the corpus callosum in two alcoholic subjects who died as a result of pulmonary complications, confirms Marchiafava's findings; the changes detected consisted chiefly in atrophic degeneration of the myelin sheaths, together with a generalized perivascular rarefaction of the parenchymal tissue, accompanied in places by microscopic haemorrhage. Both patients had shown visual and auditory hallucinations.

226. Reticulated Red Corpuscles.

CUNNINGHAM (*Arch. Int. Med.*, October 15th, 1920) gives the details of a simple technique for obtaining permanent demonstrations of the reticulation of erythrocytes. Such reticulated cells, normally present in blood to the extent of 0.3 per cent., are much increased in certain anaemias, and the appearance is generally considered to be an evidence of blood regeneration, the percentage of such cells in the blood stream giving a reliable indication of the haematopoietic activity of the blood-forming organs. The technique for their demonstration is as follows: A small drop of 0.3 or 0.5 per cent. aqueous or alcoholic solution of brilliant cresyl blue is placed on the end of a clean slide or on a cover-glass and smeared over an area of about half an inch or so by means of a match or glass rod and allowed to dry. After it is dry there may be a narrow margin of thick stain, which should be wiped off with a damp cloth, leaving a central uniform area. Such slides can be prepared beforehand and kept in stock. A fresh drop of the blood to be examined is taken on a clean cover-slip, and this is dropped face downwards on to the prepared slide. The blood quickly spreads, and the stain goes into solution almost immediately. The cover-glass is now pulled apart from the slide, and after drying is stained with Wright's blood stain. It may be mounted in Canada balsam and kept for months. The reticulum is stained blue, and gives a striking picture in contrast with the pink protoplasm of the cell.

227. Are there Several Strains of Gonococcus?

THOMSEN and VOLLMOND (*Hospitaltidende*, November 3rd, 1920) have carried out investigations at the Serum Institute in Copenhagen on cultures of gonococci obtained from the male urethra in 26 cases early in the disease. They suspected that the lack of uniformity of the reaction of various cultures of gonococci to serological tests might be due to differences of strain, such as have been recently demonstrated in the case of pneumococci and meningococci. They also wondered whether it might not be possible to correlate serological peculiarities of certain strains with peculiarities in the clinical picture. After describing in detail their serological tests (complement fixation, agglutination, etc.), they conclude that of their 26 pure cultures, 14 could be classed under one heading (Type A), 5 under another heading (Type B), and 5 under a third heading (Type C). The remaining two cultures could not be fitted into any of the above three classes. Of the 14 cases belonging to Type A, 5 were complicated by epididymitis and prostatitis. Of the 5 cases belonging to Type B, 3 were slight, 2 were protracted. All the 5 cases belonging to Type C were slight and uncomplicated.

EPITOME OF CURRENT MEDICAL LITERATURE.

MEDICINE.

228. X-ray Examination of the Chest in Acute Respiratory Affections in Children.

RUSCA (*La Pediatria*, January 1st, 1921), as the result of his researches, came to the following conclusions: (1) X-ray examination in the child is of considerable diagnostic value in the not infrequent cases in which pneumonia is suspected, although the physical signs do not justify the diagnosis. (2) Lobar pneumonia in infancy is shown by x-ray examination to be more frequent than the ordinary physical signs suggest, while, on the other hand, central pneumonia is quite exceptional. (3) Fully developed lobar pneumonia has a definite radiological picture corresponding to the ordinary physical signs. Both at the beginning and end of the morbid process a shadow can be found on x-ray examination when the clinical signs are still absent, or when they have disappeared entirely. (4) X-rays show the exact situation of hepatization, which is often not found by ordinary physical examination. (5) X-rays may be of some assistance in distinguishing between lobar pneumonia and caseous bronchopneumonia in small children. (6) Bronchopneumonia never shows a triangular area on the screen; the radiological pictures are inconstant, not always corresponding to the clinical findings, and radiological differentiation of the various forms of bronchopneumonia is impossible. (7) Pleurisy with effusion and empyema show the same radiological picture in children as in the adult. (8) X-ray examination in acute respiratory affections in children, though in some cases it may be of great value, especially in establishing the exact extent of the inflammatory focus, cannot, and ought not to, take the place of the ordinary methods of physical examination, but should be used in conjunction with them in establishing the exact diagnosis.

229. Recklinghausen's Disease.

CASTRONOVO (*Rif. Med.*, September 4th, 1920), in a review of this disease, says that the three cardinal symptoms are cutaneous fibromata, fibroma of the nerves, and pigmentation of the skin. As in other diseases, there may be mixed forms and abortive types. The nerve fibromata may affect any nerve, but most commonly are found in the peripheral nerves and their roots, the cauda equina, and the cerebellum. Secondary lesions in the cerebro-spinal axis are not common, but when present take the form of sclerosis of the cord. The nerve fibromata are seldom single; they appear as easily enucleable tumours in the centre of the nerve trunks, or as voluminous tumours attached to the small nerves. Occasionally the tumours develop in mucous membrane or in internal organs. The skin tumours may reach very large numbers (for example, 7,000 in Profeta's case), and are of all sizes and weight. The genital organs, the soles of the feet, and the palms of the hands are usually exempt. The tumours arise from connective tissue, and consist of fusiform cells with an oval nucleus; they have little tendency to contraction or sclerosis. In the nerves they may start from the endoneurium, the sheath of Schwann, or from the blood vessels and lymphatics of the connective tissue of the perineurium. The pigmentation may be punctiform, macular, or a diffuse greyish-yellow mask-like appearance (*facies fannica*). The disease is frequently associated with congenital lipomata, plexiform neuromata, syringomyelia, and certain other dystrophies—for example, bony malformations. Malignant transformation occurs in 12 per cent. of the cases, according to Gairé. A case (with photographs) of the disease is recorded by the author. Recklinghausen's disease is often congenital and hereditary; of the various theories as to its cause the author favours that which associates it with disease of the endocrine system. Arsenic, opotherapy, fibrolysin, and surgical treatment have all done good.

230. Dentition and Febrile Processes.

ABELS (*Wien. Klin. Woch.*, October 28th, 1920) states that hitherto two different views have been held as to the so-called diseases of dentition. On the one hand are those who attribute all possible diseases to the process of dentition, while the other party denies that dentition is responsible for any morbid phenomena. Abels now propounds a third view which, in his opinion, gives the best explanation

of the question—namely, that there has been a confusion of cause and effect, the fact being that febrile processes are followed by eruption of teeth. He illustrates this by observations made during a recent epidemic of measles.

231. Trauma and Other Non-specific Influences in Paresis.

MICHAEL OSNATO (*Journ. of Nervous and Mental Disease*, August, 1920) considers the bearing of head injury and other influences on the causation of paresis, apart from a syphilitic etiology. He quotes a series of thirteen cases of general paralysis, nine of which had a history of head injury. The date of the injury and its character are described. In all cases a positive Wassermann reaction was obtained in the blood and cerebro-spinal fluid. Colloidal gold reactions were done in four of the cases, and showed the paretic reaction, and the symptoms described point to paresis, except one which was considered a case of cerebro-spinal syphilis, and improved under treatment. In all of the cases the symptoms began immediately after the injury—that is, a few days in most cases, and not more than a few weeks later in any of them. Considerable interest attaches to the remaining four cases. One was that of a physician who had an operation chancre on his finger, and developed tabes sixteen years afterwards. After developing bed-sores and cystitis he fell when trying to walk, and broke his right ankle. Typical paretic symptoms developed almost at once. Of the remaining three, one developed paresis after prolonged etherization, one after influenza, and one after a mental breakdown—psychical trauma. The general course of the disease was the usual one, and treatment gave no better results than in cases uncomplicated by trauma. Os nato suggests several conclusions: That trauma in a syphilitic may give the spirochaetes an opportunity for invasion; that the course of the disease may be hastened by the changes secondary to injury; that toxins, as influenza, alcohol, or ether, may have an influence similar to trauma in syphilitics and produce paresis; and that any syphilitic suffering from head injury should immediately be given prolonged rest and active intensive antisymphilitic treatment with a view to killing as promptly as possible any spirochaetes which may have gained access to the brain substance. Lastly, one must be prepared for a possible paretic reaction following infections or prolonged etherization in a known syphilitic.

232. Sudden Death in Pertussis.

NASSO (*Pediatria*, June 21st, 1920) reports the case of a child, aged 14 months, who suffered from whooping-cough for about a month. The paroxysms of cough were sometimes replaced by paroxysms of sneezing, and after one such attack the child suddenly expired. At the autopsy slight lymphatism was noted; the upper air passages, trachea, and large bronchi were free. The lungs were anaemic, with small hyperaemic foci at the base, and a nodule of red hepatization at the right apex; the bronchial glands were slightly enlarged. The cause of death was probably spasm of the glottis. Spasms of sneezing alternating with spasms of cough are occasionally met with in pertussis, but are not common.

233. Tabes and General Paralysis Preceded by Chronic Syphilitic Meningitis.

VINCENT (*Paris m'ed.*, October 2nd, 1920) relates two cases in which a latent chronic syphilitic meningitis was observed a long time before the appearance of any signs of tabes or general paralysis, and states that no examples of the kind have been previously recorded. The first case was that of a man who contracted syphilis in 1901, and was kept under observation from 1907 to 1919. From 1907 to 1912 he presented no symptoms of nervous disease, but as his wife had had a series of miscarriages he submitted to lumbar puncture, which showed a considerable lymphocytosis. During the next five years—that is, from 1907 to 1912, he was energetically treated with calomel, cyanide of mercury intravenously, bismuthide of mercury, and later salvarsan; but in 1912 symptoms of tabes developed, and in January, 1919, general paralysis supervened, which proved fatal in the following April. The second case was that of a man who had contracted syphilis in 1904, and from 1911 to 1914 showed considerable cerebro-spinal lymphocytosis,

and the signs of nervous disease. In spite of active treatment from December, 1913, until August, 1914, signs of tubercle developed during the war, though the exact time could not be determined.

234. Decline of Tuberculosis in Denmark.

JENSEN (*Ugeskrift for Læger*, January 6th, 1921) publishes a statistical paper showing the enormous decline of tuberculosis in Danish towns since 1890. In this year there were 32.38 deaths in Copenhagen from all forms of tuberculosis per 1,000 inhabitants; in 1919 this figure was reduced to 13.24. In the provincial towns the mortality from all forms of tuberculosis fell from 28.75 per 1,000 in 1890 to 11.04 in 1919. One curious finding was this: that while in Copenhagen during the latter half of this thirty-year period the decline in the tuberculosis mortality kept pace almost exactly with the decline in the mortality from all causes, in the provincial towns the decline in the tuberculosis mortality was considerably more rapid than the general decline. The author offers no explanation for this apparently anomalous finding. In 1916 and 1917 there was a slight rise of the tuberculosis mortality, with the result that for the five-year period 1915-19 it was slightly greater than for the preceding five-year period; but the decline was resumed in 1918 and again in 1919—a year in which a record low level was achieved.

235. Tritol (Trinitrotoluol) Poisoning.

RUBINO (*Rif. Med.*, December 4th, 1920) gives the result of an examination of about 100 workmen engaged in the manufacture of tritol. In Italy the toxic effects have not been so severe as in England or America (in New York there were 2,507 cases of poisoning, with 53 deaths, and in England, in 1916 alone, 52 deaths); the author attributes the higher mortality in England to the greater prevalence of alcoholism, which predisposes to intoxication from tritol. He attaches great value to the Webster urine test as an early sign. In view of the great infrequency of dermatitis, he thinks intoxication does not proceed by way of the skin but through the digestive tract and by inhalation. Gases may penetrate the skin. The irritating effect of nitrous vapour on the bronchi is well known, and it also affects the blood. Most workers are affected at the beginning, but after a time get acclimatized; in a certain number later poisoning takes place, and this is more likely if they are affected with any digestive disturbance. Wasting is a common symptom. Jaundice was rare amongst the men examined by him; headache, giddiness, and anaemia were observed. Certain prophylactic measures were recommended: (1) Limitation of the hours of work to six or seven hours, with frequent intervals; (2) mechanical means in the operation of nitration; (3) special working clothes, including masks and gloves; (4) no food to be eaten on the premises, and the hands and face to be washed previously; (5) instructions as to the danger of the work.

236. Lethargic Encephalitis in Switzerland.

BAUER and MAYER (*Rev. méd. Suisse rom.*, October, 1920) state that 29 cases of lethargic encephalitis occurred in the canton of Neuchâtel, or its environs, from February to May, 1920, as compared with 3 during the same period in 1919. The writers describe the following types: (1) cortical type with forms of acute delirium, simulating delirium tremens, general paralysis, and other psychoses, and forms of Jacksonian epilepsy and Broca's aphasia; (2) a classical mid-brain type, myoclonic or lethargic in character; (3) a meningeal type, very difficult to distinguish from tuberculous meningitis; (4) forms of unknown localization, simulating hysteria and other neuroses. The mortality among the 29 cases was 5, or 17.2 per cent.

237. Roughness of the Skin in Tuberculous Subjects.

ACCORDING TO GARGIULO (*Rif. Med.*, July 24th, 1920), the subjects of tuberculosis, whether pulmonary or abdominal, develop, in 90 per cent. of the cases, a noticeable roughness and harshness of the skin of the forearm. This, he suggests, may possibly be associated with loss of flesh or with the sweating which is common in tuberculous disease.

238. The Use of Sodium Morrhuate in Pulmonary Tuberculosis.

M. BIESENTHAL (*Amer. Rev. of Tuberc.*, December, 1920) tried this preparation on twenty-five patients, to see if he could corroborate Rogers's statement that it "was the best line of treatment for tuberculosis in general." He injected a 3 per cent. solution in water subcutaneously, in doses of 1 mg., increased by $\frac{1}{2}$ mg. in semi-weekly injections until 1 mg. was reached, and then weekly injections. Altogether

430 injections were given. He found no rapid diminution of sputum, no greater average gain in weight than in those not under this special treatment, no reduction of temperature, and very little improvement in the physical signs. No special or serious reactions were noted. He does not, therefore, agree with Rogers's conclusions.

239. The Capillary Pressure.

KYLIN (*Zentralbl. f. inn. Med.*, July 17th, 1920) measured the capillary pressure with a specially constructed apparatus in 100 healthy men, and found that the readings ranged from 110 to 190 mm. H₂O. He considers it possible, however, that the usual range may be between 100 and 200 mm. H₂O. He also examined the capillary pressure in twenty cases of mild renal sclerosis, in all of which it was normal, and never exceeded 190 mm. H₂O. On the other hand, examination of the capillary pressure in 100 cases of acute glomerular nephritis showed that it was constantly raised in that condition, and to a considerable height, readings of over 500 mm. H₂O being frequent. The highest reading was 750 mm. H₂O, which is equivalent to 55 mm. Hg. On recovery the capillary pressure sank like the arterial blood pressure. It is not unusual for acute glomerular nephritis not to show a rise of arterial pressure. In ten cases of acute glomerular nephritis observed by Kylin in which there was no rise of arterial pressure all showed a distinct rise of capillary pressure. The capillary pressure is, therefore, a valuable means of distinguishing true from apparent focal nephritis.

SURGERY.

240. Etiology and Prophylaxis of Post-operative Jejunal Ulcer.

DENK (*Wien. klin. Woch.*, January 6th, 1921) states that the increase in the number of operations on the stomach and duodenum has been accompanied by an increase in the number of jejunal ulcers observed. This complication is most frequent after gastro-enterostomy for duodenal ulcer and very rare after gastro-enterostomy for an ulcer some distance from the pylorus. Denk considers that gastro-jejunal ulceration at the anastomosis is probably due to disturbances in the healing process of the suture of the mucous membrane due to persistence of silk ligatures and to early administration of solid food. Ulcers situated exclusively in the jejunum have been variously attributed to mechanical, chemical, circulatory, and nervous factors. The best method of prophylaxis, according to Denk, is Billroth's operation or extensive gastric resection, as recommended by Schnitzler, Schur, Plaschkes, and Finsterer. In gastro-enterostomy care should be taken to avoid injuring the mucous membrane, and the same diet should be given for several weeks. When a neurotic element is present, atropine, papaverin, or belladonna is indicated.

241. Rectal Anaesthesia.

BALSAMO (*Rif. Med.*, September 11th, 1920), after a reference to the history of rectal anaesthesia with ether, mentions some of the drawbacks of the method. (1) Deaths have been reported in 8 cases out of 2,500. (2) Distension of the bowel may interfere with operative procedures. There may be: (3) intestinal haemorrhage; (4) incomplete narcosis; (5) collapse and respiratory disturbance; (6) subsequent vomiting and abdominal pain. (7) The procedure is contraindicated in diarrhoea and intestinal disease, especially tuberculous disease. (8) Long preparation of the patient is required, and anaesthesia after the operation is unnecessarily prolonged. The author has given ether per rectum two hundred times, after the method recommended by Gwathmey. Details of the various kinds of operation are given; some were urgency operations—for example, strangulated umbilical hernia, ruptured ectopic pregnancy, Caesarean section, etc. The results were very satisfactory; children seldom retained the injection long, but usually long enough to induce anaesthesia. Insufficient narcosis was observed in about 20 per cent. of the cases. The average amount of ether mixture given was 3 grams of ether for every kilogram of body weight. Vomiting during the operation was never seen; respiratory difficulty very seldom. The only case that gave any trouble was one of severe double compound fracture of the legs where tourniquets had been applied to the thighs; when the tourniquet was released and a wider distribution of the ether in the circulation allowed, the respiratory trouble quickly disappeared. Post-operative haemorrhage which might be attributed to the ether occurred in 3 cases but was only slight. In

one of these cases—a case of plastic surgery of the face—the patient had previously been given five rectal injections of ether at intervals of about a month. Slight diarrhoea was noted in 18 cases.

242. Indications for Operation in Cholelithiasis.

HEIDENHAIN (*Zentralbl. f. Chir.*, January 8th, 1921) furnishes statistics of 570 operations for gall-stone disease. His figures, like those of other observers, show that a large proportion of the patients—in Worms nearly 53 per cent.—come for operation much too late. His first group of cases was composed of 269 relatively simple cases, such as stone in the gall bladder, with a mortality of 1.5 per cent. The second group consisted of 106 cases of cholelithiasis with well marked septicaemia or peritonitis, with a mortality of 14.1 per cent. The third group consisted of 158 cases of stone in the common bile duct, with a mortality of 4.8 per cent., and the fourth group of 37 cases of cancer, with an immediate mortality of 30 per cent. and no ultimate recovery. The second and third groups thus comprised 264 cases with 38 deaths, of which 29, or 76.5 per cent., were due to chronic myocarditis, septicaemia, cholaemia, cholecystitis, and inanition. Operation is invariably indicated in acute cholecystitis with fever and a palpable gall bladder, because, as in appendicitis, one can never tell how the process will terminate. Very good results are to be obtained from operation during an attack of gall-stone colic. Operation is also indicated in chronic relapsing gall-stone disease as soon as the general condition begins to be affected.

243. Vaccine Treatment in Oto-Rhino-Laryngology.

ERATH (*Rev. de lar., d'otol., et de rhinol.*, November 15th, 1920) regards vaccine treatment as an extremely valuable method in the treatment of chronic suppurative affections of the ear, nose, and accessory sinuses when the disease is confined to the mucous membrane. Vaccine treatment naturally does not exclude surgical measures in cases of definite bone lesions such as sequestra, or of cholesteatoma, polyp, and malformations, but it very often renders unnecessary an operation which might be required for suppuration only, as in sinusitis.

244. Pharyngeal Suppuration Secondary to Mastoid Abscess.

ACCORDING to MOREAUX (*Rev. de lar., d'otol., et de rhinol.*, December 31st, 1920), who reports two examples, pharyngeal suppuration secondary to a mastoid abscess may develop acutely with all the symptoms of a peritonsillar abscess, or be discovered only by accident owing to a special examination being made, or owing to some accessory symptom such as chronic purulent expectoration or oral foetor. The diagnosis of pharyngeal suppuration of otitic origin may be difficult, and is established by the history, it being borne in mind that a mastoid abscess may be present after an acute or chronic otitis has cicatrized. In cases of pharyngeal suppuration coexisting with suppurative otitis media, symptoms of pain in the neck, tenderness along the large vessels, and torticollis, are a guide. Bacteriological examination should always be made of the pus from the ear and from the pharynx, and will reveal the identity of the causal micro-organisms. The differential diagnosis must be made from peritonsillar abscess, subaponeurotic abscess, and retropharyngeal abscess secondary to disease of the vertebrae.

245. Influence of Age upon Astigmatism.

A. W. STIRLING (*Archives of Ophthalmology*, January, 1921) says that the commonly accepted dictum is that a convex cylinder "with the rule" tends to be vertical, and a concave lens horizontal, the reverse in either case being spoken of as "against the rule." His figures go to show that the "rule" that the axis in hypermetropic astigmatism tends to be vertical, while correct for the young, is incorrect in the elderly; they indicate that there is quite commonly a rotatory movement of the axis, proceeding slowly with the passage of time; they further show that in hypermetropic and in myopic eyes there is a definitely greater tendency for the meridian of greater corneal convexity to wheel towards the nose than away from it—that is, of course, if the astigmatism is corneal in origin and not lenticular, a fact which can be settled by using the ophthalmometer. In the later decades of life a large proportion of lenses show peripheral striae, and it may be that these changes may have something to do with changing the axis of the cylinder, but, apart from this fact, Stirling's figures go to prove the truth of his assertion. The whole question of the change of the axis in astigmatism is one requiring research by one of the older ophthalmic surgeons now in practice, for

it is only by examining a large series of records of cases extending over many years that positive evidence can be obtained. Stirling's paper does not go into any of the effects of astigmatism, but it is a valuable attempt to throw light on a part of the subject which up till now has been largely or altogether neglected.

OBSTETRICS AND GYNAECOLOGY.

246. Prognostic Significance of the Escape of Meconium.

GEJROT (*Hyg. t.*, December 16th, 1920) has investigated the relation of the *intra partum* escape of meconium to the incidence of asphyxia and stillbirth in a series of 6,437 births (all head presentations) recorded at a maternity hospital between January 1st, 1917, and September 30th, 1919. In 369, or 5.72 per cent., meconium escaped *intra partum*. Of these 369 infants, 308 were alive and well at birth, 37 were slightly and 11 were severely asphyxiated (only 5 of the latter class were resuscitated), and 13 were stillborn. When the cases were classified according as the meconium escaped before or after the rupture of the membranes, it was found that the prognosis for the infant was determined much more by the length of the interval between rupture of the membranes and completion of labour than by the escape or retention of meconium. The author concludes that slight asphyxia *intra partum* does not provoke the escape of meconium, whereas severe asphyxia usually does so. After the escape of the liquor amnii, he holds that the pressure of the maternal parts may alone be sufficient to force meconium out of the infant's gut. In most cases, however, he regards the escape of meconium *intra partum* as a juxtaphysiological act dependent on a certain liveliness of peristalsis. In this connexion he refers to the classical experiments of Porak and Runge, who found that large doses of quinine sulphate, given to the mother, caused the escape of meconium *intra partum* in about 50 per cent. of the infants, and this effect was traced to the peristaltic action of the drug on the infant's gut.

247. Treatment of Hyperemesis Gravidarum.

PERY (*Gaz. heb. des Sciences Méd. de Bordeaux*, December 12th, 1920) records two cases of intractable vomiting of pregnancy. In the first the ordinary therapeutic measures and an injection of horse serum were attended by failure, but a cure was at once established by injection of several cubic centimetres of the serum of a pregnant woman. In the second case such an injection failed, as also the more usual treatments; a slow improvement took place after a dilatable bag had been placed in the vagina to correct a somewhat exaggerated uterine anteversion.

248. Delivery through a Cervical Laceration.

V. HEISS (*Zentralbl. f. Gynäk.*, November 27th, 1920) records two cases presenting features of forensic interest. In the first, inevitable abortion in a primipara, aged 32, was treated by cervical dilatation (Hegar's sound, to number 7) and introduction of a bougie; subsequently further dilatation (to number 12) was performed, and a Braun's bag introduced into the uterus. Six hours later the five months foetus and placenta were found to have been expelled through a transverse tear situated in the posterior cervical wall 3 cm. above the external os. The second patient, aged 24, was nulliparous; a five months pregnancy was interrupted on account of puerperal insanity. The tear was similarly situated to that of the first case. The operative treatment in each case was performed deliberately and carefully, so that gross injury to the cervical wall could be excluded as a cause of the tears, which the author attributes to rigidity of the cervix.

249. A Physical Sign of Ovarian Cyst.

DANIEL (*Gynec. et Obstét.*, 1920, i, 6) gives an account of the sign which he described to the Urological Society of Bucharest in December, 1919; it may be of value, he thinks, in the diagnosis of ovarian cysts. Standing at the patient's right, with his face directed towards the patient's pubis, the examiner, with his left hand, pushes the swelling to the right side of the abdomen, at the same time lifting it in an external direction; the right hand, through the thickness of the abdominal wall, seizes the wall of the tumour between the thumb and two fingers. The result of this "pinching" is that the portion of the cyst wall which has been taken up glides suddenly away from the fingers. This test is applicable especially to flaccid, unilocular, thin-walled cysts of moderate size.

PATHOLOGY.

250. **Gummata of the Lung.**

LAZARUS (C.R. Soc. Biologie, November 27th, 1920), who has studied several cases of pulmonary gummata, says they may be observed at any age and may accompany other syphilitic lesions of the lung. They have no typical localization, being vascular in origin, but, as the vessels accompany the bronchi, gummata are always related thereto. Their number is limited; they may exist in one or both lungs. Their size is proportional to the importance of the vessel primarily affected: in general they vary in size from that of a pea to that of a turkey's egg. Their origin explains how central gummata of moderate size are spherical, whilst peripheral gummata are coniform. They are white in colour, yellow when necrosis takes place, and reddish if there is congestion. Sometimes they are marbled by anthracosis. The initial vascular lesion is almost always an acute endarteritis. Soon after its formation the gumma is crowded with spirochaetes, but as necrosis and cellular disintegration advance they can no longer be found. Around the gumma there is a zone of congestion and a reaction on the part of the pulmonary tissues. In the alveoli may be found an albuminous exudate, with epithelial cell desquamation and immigration of leucocytes. Then there appear the fibroblasts, lymphocytes, plasma cells, giant cells, and the other cells which go to form granulation tissue. The pulmonary tissue, even when richly infiltrated with spirochaetes, does not show gummata but merely pneumonic lesions, unless there has been obliteration of the vessels. The inflammatory zone on the periphery may become fibrous (fibrous gumma), and this tissue, becoming hyaline, may allow of infiltration by calcium salts (the calcified gumma). The gummatus necrosis affects a variable number of bronchi, which may ulcerate, and a cavity may thus be left which becomes infected secondarily, giving rise to the suppurating gumma. This may or may not be evacuated by the bronchi. If an infection supervenes gangrenous complications may ensue.

251. **The Different Types of Pneumococcus.**

THOMSEN and CHRISTENSEN (*Hospitaltidende*, November 24th, 1920) have carried out investigations at the Serum Institute in Copenhagen which indicate that the differences between the various types of pneumococci are practically as great as between pneumococci and other micro-organisms found in the sputum. Just as pneumococci can be obtained in pure culture by injecting a mixture of micro-organisms into the peritoneal cavity or subcutaneous tissues of a mouse and cultivating the pneumococci found in its blood or spleen, so the various types of pneumococci may be separated by the following procedure: A pure culture of Type I being required, a mixture of Types I and II are injected together with the specific serum corresponding to Type II. Type II being thus made innocuous, culture of the mouse's blood yields only colonies belonging to Type I. The authors record several experiments, one more or less accidental, illustrating the distinctness of the different types. Working with what they thought was a pure culture of Type I, they anticipated that 0.1 to 0.2 c.cm. of the homologous serum would protect the mouse from an injection of 0.05 to 0.1 c.cm. of the bouillon culture. But the mice invariably died, and all the pneumococci cultivated from the blood, spleen, and peritoneal cavity were found to belong to Type III. Thus, the presumption that the original culture contained only Type I proved to be erroneous, and when at last an absolutely pure culture was obtained, 0.2 c.cm. of the homologous serum gave immunity to an injection of 0.05 to 0.1 c.cm. of bouillon culture. The authors conclude that these and similar experiments plainly indicate the necessity for using a type-specific serum in the treatment of pneumococcal infections.

252. **Indol in Cerebro-spinal Fluid in Influenza Meningitis.**

ACCORDING to RIVERS (*Journ. Amer. Med. Assoc.*, November 27th, 1920), eleven out of twelve strains of *B. influenzae* found in cases of influenza meningitis were indol formers. With the exception of *B. coli*—an exceedingly rare cause of meningitis—none of the other organisms usually causing meningitis (meningococci, pneumococci, streptococci, or staphylococci) forms indol. To an ether extraction of the cerebro-spinal fluid is added Ehrlich's reagent (paradimethylamidobenzaldehyde, 4 parts; absolute alcohol, 380 parts; concentrated hydrochloric acid, 80 parts); the presence of indol is signified by an old rose coloured ring at the plane of contact. The test is negative in the fresh

fluid, but faintly positive after a few hours' incubation. If the growth of the bacilli is aided by the addition of one drop of sterile blood to 10 c.cm. of the spinal fluid before incubation the reaction is accelerated and intensified, becoming in some instances strongly positive in three hours.

253. **Complement Fixation Tests in the Hosts of *Bothriocephalus*.**

BECKER (*Finska Läkarsällskapets Handlingar*, November-December, 1920) has carried one step further the investigations of Tallqvist and others into the serological problems associated with the *Bothriocephalus latus*. Applying the complement fixation test to 58 persons whose faeces contained the eggs of *Bothriocephalus latus*, he obtained haemolysis with a *Bothriocephalus latus* antigen in 50 per cent. of all his cases, whereas the reaction was positive only in one-ninth of the 92 "controls." The author is very doubtful as to the reaction being strictly specific, for he obtained positive reactions in cases of *Bothriocephalus latus* tested with an antigen obtained from an extract of taenia, as well as with the hosts of taenia whose serums were tested with a *Bothriocephalus latus* extract. The author notes that Jerlow's investigations point in the same direction as his own.

254. **Blood Ferments in Pregnancy, Carcinoma, and Pulmonary Tuberculosis.**

GRÖNBERG (*Finska Läkarsällskapets Handlingar*, November-December, 1920) has applied Abderhalden's test to the diagnosis of pregnancy, carcinoma, and pulmonary tuberculosis, taking the precaution to eliminate bias by testing the serums without knowing which belonged to "controls." He obtained a positive reaction to placental tissue from the serums of every one of the 28 cases of pregnancy in the first to the ninth month; none of the 19 "control" serums from non-pregnant persons gave a positive reaction. He also tested the serums of 23 patients suffering from carcinoma in various stages, and all gave a positive reaction to an extract of carcinomatous liver. The results were equally distinctive in the case of pulmonary tuberculosis, all the 34 cases of this disease giving a positive reaction to an extract prepared from tuberculous lungs. In none of the "controls" was a positive reaction obtained. In spite of these good results the author insists that Abderhalden's test will have to be much simplified before it can be of any value in hospital practice, and he finds that the omission of only one of the many details of the technique is sufficient to render the test valueless. To begin with, the investigator must make sure that his dialyzer is in perfect working order, and during 1918 and 1919 the author had to reject as many as 70 per cent. of the dialyzers tested.

255. **Neutrophile Leucocytes in Pulmonary Tuberculosis.**

ACCORDING to ARLOING (*Journ. de Méd. de Lyon*, December 5th, 1920), investigation of the neutrophile leucocyte blood count according to Arneht's formula has diagnostic and prognostic value in cases of pulmonary tuberculosis. The changes in the Arneht figure are determined by the gravity of the infection and by the patient's power of resistance, rather than by the degree of advancement existing at the particular moment in the course of the infection.

256. **A Spirochaete Associated with Psoriasis.**

RASCH of Christiania reports the discovery, both in the skin and in the circulating blood of persons suffering from psoriasis, of a spirochaete which multiplies by sporulation, and is called by him *Spirochaeta sporogona psoriasis*. In sections of the skin the parasite has a thickness of 0.25 to 0.5 μ and a length varying between 5 and 50 μ . In the blood detection of the spirochaete is difficult; it is most frequently found in rings or small spiral forms, some of which lie within the erythrocytes. Macrogaetes and microgaetes are also described and illustrations are given of these and the other parasitic forms.

257. **An Unusual Case of Sarcoma.**

KUMEN (*Wien. Min. Wech.*, December 9th, 1920) records the case of a woman, aged 22, who from the age of 9 had had a nodule in the left frontal region which soon began to ulcerate. The condition was regarded as a gumma due to inherited syphilis and for ten years antisyphilitic treatment was employed without success. When the patient was seen by Kumén the Wassermann reaction was negative, and histological examination showed that the growth was a mixed-celled sarcoma. Kumén regarded it as a primary sarcoma originating in the bone and periosteum.

EPITOME OF CURRENT MEDICAL LITERATURE.

MEDICINE.

258. Tuberculosis and Heredity.

LUNDBORG (*Svenska Läkaresällskapet Hovälingar*, September 30th, 1920) enumerates several arguments in support of the theory that racial homogeneity is a powerful factor, preventing degenerative phenomena, including a predisposition to tuberculosis. The pure bred Jew and gipsy are comparatively immune to tuberculosis even when living in poverty and under other unfavourable conditions, but as soon as they intermarry with other races this immunity quickly disappears. In the north of Sweden, where Swedes, Finns, and Lapps have intermarried, the tuberculosis mortality is high, whereas in the south, with its pure-bred Swedish population, the incidence of tuberculosis is much less. Again, in Iceland the low incidence of tuberculosis may be correlated with the racial isolation of its inhabitants. The same argument applies to the south of Italy, Sardinia, and Sicily, where the incidence of tuberculosis is low in spite of defective hygiene. On the other hand, countries such as Poland and Austria, with racially mixed populations, suffer greatly from tuberculosis. The author produces many other arguments in support of his views, and he suggests that measures directed against tuberculosis simply as a disease of infection and of other extraneous circumstances can be only partially successful; only when tuberculosis is treated also as a disease determined by race biology and heredity can its control be achieved.

259. Protein Therapy in Pneumonia.

MONGUZZI (*Il Policlino*, Sez. Prat., October 4th, 1920) gives an account of protein therapy in 22 cases of pneumonia or bronchopneumonia, which he divides into four groups. In the first group, consisting of 11 patients, a single intramuscular injection of 10 c.cm. of sterilized milk was given. The result was good in each case, and in two surprisingly so, as the pneumonic process subsided within thirty-six hours after the injection. In the second group, which consisted of 7 patients, three injections of milk were given, with an interval of a day between the first and second injections and an interval of forty-eight hours between the second and third. Recovery was rapid after the third injection. In the third group, which consisted of 3 cases, the injection of milk was not followed by any objective or subjective improvement. An intramuscular injection of 200 million of a stock gonococcus vaccine was then given, and was followed by a slight rigor and sharp rise of temperature. The injection was repeated next day with a similar result; recovery henceforward was rapid. The fourth group was represented by a single fatal case, in which an injection of milk, followed by stock gonococcus vaccine, had no effect.

260. Bronchiectasis after Influenza.

PARODI (*Il Morgagni*, June 30th, 1920) points out that acute bronchiectasis, as distinguished from the chronic forms, is not infrequent after measles, influenza, and whooping-cough—in this order of frequency. Although bronchiectasis follows changes in the bronchial parietes, not every lesion of the bronchi is followed by bronchiectasis, but only certain types. As the result of a study of several cases and pathological reports, the author concludes that in acute bronchiectasis there is always in the very earliest stages a functional alteration of the bronchial walls, followed by severe bronchitis (generally purulent), causing infiltration of the parietes, peribronchial structures and alveoli, and finally leading to bronchiectasis. Full details are given of two cases. As regards treatment, in almost every case the author advises artificial pneumothorax; where the walls of the bronchi are rigid and sclerotic pneumothorax is dangerous, and thoracoplastic operation is more suitable.

261. Vaccine Therapy in Typhoid.

BOZZOLO and FANZIO (*Il Morgagni*, August 31st, 1920) have treated 57 cases of typhoid with a choleraic vaccine prepared by Loeffler. The usual reaction after an intravenous injection followed—shivering, rise of temperature, sweating, etc. The results on the whole were good; in some cases only one injection was necessary—a critical lowering

of temperature took place in 25 per cent. of the cases, and in 30 per cent. a decided diminution in temperature and improvement in the general state followed. On the other hand, 33 per cent. proved refractory to this treatment. The best time to use vaccine therapy is said to be between the tenth and fifteenth day of the disease. In some cases it may excite hæmorrhage: it is contraindicated in advanced age, in cardio-vascular insufficiency, and where severe bronchopneumonic complications exist. There were three deaths in the 57 cases: one died immediately after injection, but in this case, at the autopsy, persistent thymus and congenital stenosis of the aorta were found to exist.

262. Familial Contagion in Lethargic Encephalitis.

DE LAROCHE (*Paris Méd.*, September 25th, 1920) states that it is exceptional for the contagious character of lethargic encephalitis to be demonstrated. Out of 114 cases Netter observed only one family in which there were two cases, and even then the first case had not been recognized. At Sarrebruck two sisters were attacked, but they were living in an epidemic environment. Laroche reports the case of a gendarme who developed lethargic encephalitis on April 20th in a small town in the Orne, about one and a half months after returning from Lyons, where the disease was prevalent. He was nursed by his wife from the onset of his illness until May 28th, when he was taken to hospital. At the commencement of June the wife contracted a severe form of the disease, which proved fatal within three weeks. As she had not been to Lyons the author considers that she must have been infected by her husband, although she did not develop the disease until forty days after the onset of his illness. Thus the incubation period in both husband and wife was fairly long.

263. Rupture of the Spleen in Malaria.

ACCORDING to MASSARI (*Wien. Klin. Woch.*, October 14th, 1920), who records an illustrative case in a man aged 23, most of the recorded cases of rupture of the spleen have been discovered only at autopsy. Thus while in some districts of India malarial rupture of the spleen is so frequent that Crawford found 477 examples among 3,884 autopsies, or in 4.45 per cent., reports of cases in which an operation has been performed are extremely rare, which is due to the circumstances of life in the tropics and the superstition and indolence of the natives. Noland and Watson (1913), who during the construction of the Panama Canal operated on three cases of rupture of the spleen among 23,000 malaria patients, state that the patients were able to continue their work for a certain time after the rupture had taken place. In addition to his own case, in which operation was successful, Massari has collected twenty other cases of operation for rupture of the spleen in malaria, 14 of which recovered, and 6 died. The prognosis depends on the rapidity with which the operation is performed after the accident has occurred. Massari concludes by saying that owing to the large number of cases of malaria due to the war the possibility of rupture of the spleen due to a slight trauma should be borne in mind. Patients and their friends should be warned as to the vulnerability of the malarial spleen, and instructions should be given to all first-aid stations, police stations, etc., that no time should be lost in obtaining surgical assistance.

264. Chloroma in Infancy.

Ref. Med. (December 4th, 1920), in a review of recent literature on this disease, refers to forty-six cases collected by MENSI, who says that neither heredity, previous diseases, syphilis, rickets, tuberculosis, or injury, play any definite part in the etiology. The classical type arises from the bones of the face or head, causing exophthalmos, visual and auditory disturbances, anaemia, hæmorrhages, ulceration, stomatitis, and death in a few weeks. There is a diminution in the nitrogen, urea, ammonia, and uric acid of the urine. Radiography shows proliferation of the cranial bony tissue, separation of the sutures, areas of rarefaction in the medullary parts of the long bones and raising of the periosteum. These changes help to differentiate chloroma from scurvy, rickets, sarcoma, or syphilis. The blood changes are usually of a macrolymphocyte type with myeloblasts or myelocytes. Prognosis is bad and treatment inefficacious.

255. Melaena Neonatorum Treated with Horse Serum.

FUVA (*Brit. Med.*, October 30th, 1920) speaks highly of the value of injection of horse serum in the treatment of melaena neonatorum. Excluding spurious melaena from blood swallowed from the nasopharynx or from the mother, and melaena due to syphilis, sepsis, haemophilia, there still remain many cases of unknown origin. But, whatever the cause, horse serum is efficacious. The author briefly records five cases in infants, all successfully treated by injections of horse serum: some of the patients, in addition, had calcium chloride and gelatine, but the effective agent seemed to be the serum. Two or three injections of 10 c.cm. each were given at intervals of twenty-four hours.

266. Arthropathies in Sclerodermia.

ACCORDING to ADRIAN and ROEDERER (*Ann. de Derm. et de Syph.*, Nos. 6-9, 1920), sclerodermia in rare cases is complicated by changes in the joints which as a rule precede the skin lesions, and only rarely accompany or succeed them. In the absence of skin changes it is impossible to differentiate these arthropathies from other chronic affections of the joints. The age most susceptible to the arthropathies of sclerodermia is that from 31 to 40: the smallest number of cases occurs below 10 years of age. The largest number and the severest attacks are found in the female sex: damp, cold, and chill seem to predispose to the affection. The changes may affect one or more joints, disappear after a certain time, and then recur. In some cases the joints may not undergo any pathological change. In the great majority of cases the onset of these arthropathies is insidious, but in some cases there is an acute onset, in which the joints are painful and tender and the skin covering them is tense and hot. Next to the finger-joints the knee-joint is most frequently affected. The muscles, tendons, tendon sheaths, synovial membranes, and bones may be attacked; in rare cases the heart and thyroid may be implicated. The prognosis is good in the forms manifested by arthralgia only, but is more serious in the cases characterized by progressive affection of several joints and marked deformities. Treatment is usually ineffective.

257. Respiratory Mycoses

BASILE (*I Policlinico. Sez. Prat.*, October 18th, 1920) states that mycosis of the respiratory system may be regarded as a clinical entity caused by various species of fungi, such as *nocardia*, *monilia*, *mucor*, *aspergillus*, *penicillium*, *hemispora*, *oidium*, and *sporotrichum*. The symptoms resemble those of tuberculosis. In moniliasis and oidiomycosis there is considerable loss of flesh, all the visible mucous membranes are pale, and examination of the blood shows considerable diminution of the red cells and haemoglobin. The patients also have an oral foetor which disappears after treatment. There are no night sweats. The infection may take an acute or chronic course. The average duration of the acute forms is thirty to fifty days, that of the chronic forms varies considerably. The respiratory symptoms and signs consist in pain in the chest, dyspnoea, crepitations, bronchial breathing, and pleural friction. The sputum is profuse and blood-stained. The liver is tender and not infrequently extends below the costal margin. In most cases the spleen cannot be felt. There is anorexia and sometimes diarrhoea. The urine may contain albumin: this is always of grave prognosis. In most cases treatment by iodides given by mouth or by intramuscular or intravenous injection is efficacious, nocardiasis proving the most refractory.

268. The Distribution of Lupus Vulgaris.

WITH (*British Journ. of Dermatology*, October, 1920), states that examination of 900 patients treated at the Pineson Light Institute, Copenhagen, confirmed the old observation regarding the frequency of lupus on and in the nose. In children lupus in this situation was rare compared with lupus in the centre of the cheek, but increased in frequency between the ages of 11 and 16. At this age it was comparatively common on the extremities.

269. Splenomegaly due to Arsenobenzol.

LÉVY-FRANCKEL (*Bull. Soc. de Théor.*, November 10th, 1920) describes two cases of splenomegaly following injections of neo-salvarsan—in a boy aged 13, suffering from lupus, and a soldier suffering from psoriasis: in both the Wassermann reaction was negative. Leukaemia and pseudo-

leukaemia could be excluded by examination of the blood, and the complete subsidence of the splenomegaly negated the diagnosis of primary tuberculosis or cancer of the spleen. Lévy-Franckel therefore concludes that the splenomegaly was due to the arsenobenzol, although no previous cases of this kind have been described.

SURGERY.

270. Acute Otogenic Meningitis.

SURREAU (*Rev. de l'otol., et de rhinol.*, November 15th, 1920), in his Lyons thesis, states that the predisposing causes of acute otitic meningitis are bad hygienic conditions (which were particularly marked during the war), alcoholism, diabetes, adult age, and infectious diseases. Invasion of the meninges occurs (1) as the result of a trauma, the fracture opening a direct path to infection; (2) via the bones of the skull; (3) by rupture of an abscess into the arachnoid cavity. The lesions observed are of three kinds—namely, serous, purulent, and tuberculous meningitis. The purulent sometimes succeeds the serous form. In some cases only a generalized venous congestion is found, in others there are purulent patches, but the disease almost always occurs in persons whose mastoid process contains only a few cells. There is nothing special in the symptomatology, which is the same as that of every other form of meningitis. The clinical varieties are the fulminating form, the acute form (which is much the commonest), and the subacute form, which is very rare. Early diagnosis is important. The condition must be distinguished from the meningism occurring in infectious disease, cerebral abscess, and cerebro-spinal meningitis. Treatment should consist in destroying the infective focus by making a wide trephine opening in the mastoid and temporal fossa, and slight incisions in the dura. Hot baths and lumbar puncture are also to be recommended.

271. Acute Osteomyelitis of the Ribs.

ACCORDING to FANTOZZI (*Il Policlinico, Sez. Chir.*, December 15th, 1920), who has collected 51 cases from the literature, including one of his own, acute osteomyelitis of the ribs is very rare, but is probably more frequent than it appears, as it is very likely that numerous cases have not been recorded, in addition to others which have not been recognized. The organism most usually found is the *Staphylococcus pyogenes aureus* or *albus*. In Loughborough's case the pneumococcus was isolated. In Fantozzi's and Canon's cases the streptococcus was found. The male sex is most frequently affected. The age at which the disease is most often observed is infancy, whereas osteomyelitis in general is most frequently found in adolescence. The seventh rib is most frequently attacked, and there has been no case recorded of the first rib being involved. The clinical and pathological course is the same as that of osteomyelitis in general, the prognosis being favourable, especially when the lesion is limited to the anterior segment of the rib. Treatment is exclusively surgical, indications for operation being the same as for osteomyelitis elsewhere.

272. Diagnosis of Appendicitis.

INDEMANS (*Nederl. Tijdschr. v. Geneesk.*, January 22nd, 1921) records the following case illustrating the difficulties in the diagnosis of appendicitis. The patient was a woman, aged 35, who had suffered for three years on and off from pain in the abdomen, chiefly localized in the right ileo-caecal region and radiating to the loins. On examination of the abdomen a large infiltration could be felt extending upwards above the line connecting the umbilicus with the anterior superior spine and downwards into the pelvis. Vaginal examination revealed a very large tender infiltration on either side of the uterus without any signs of softening. Micturition and defaecation were both very painful. The general condition and pulse were good, and the temperature ranged between 101.2° and 103°. A diagnosis of larval appendicitis with circumscribed peritonitis was made, and it was decided to wait and perform an operation *à froid*. Most of the infiltration was absorbed in about ten weeks, and after the temperature had been normal for about a month laparotomy was performed. A dermoid cyst containing greasy material and some pieces of bone was found adherent to the appendix. The appendix itself was 7 cm. long and showed a diverticulum 1 cm. long containing a faecal concretion the size of a cherry stone. The mucous membrane was not ulcerated, but only in a catarrhal state. The symptoms of circumscribed peri-

tonitis were probably not due to the appendix, but may have been caused by irritation of the peritoneum by torsion of the pedicle of the dermoid cyst.

273. Autotransfusion for Haemorrhage.

LOVE (*Med. Record*, January 8th, 1921), acting upon Lewishon's observation that the coagulation time of the blood could be reduced even by autotransfusion (300 c.cm. autotransfusion on a dog reducing the normal coagulation time of five minutes to ten seconds), obtained similar results in eight dogs experimented upon. After applying a tourniquet above the field the vein is punctured with a short needle and blood aspirated into a 10 to 20 c.cm. syringe to the capacity of the syringe. The tourniquet is released and, without disconnecting, the blood is injected back again. The process is repeated in one or two minutes until the total amount withdrawn and reinjected equals an ordinary transfusion. Two syringes are required, so that they can be changed about every five minutes. 0.5 per cent. sodium citrate or normal salt solution being used for rinsing the syringes between use, and at each change of syringe about 2 to 5 c.cm. of physiological salt solution should be injected to ensure a clean needle. Although the bleeding time and the coagulation time are not related in any simple manner, the experiments on bleeding time showed that wounds which would ordinarily have bled very severely, were quite easily controlled after autotransfusion. All the experiments were upon normal blood, so that the adaptability of the method for haemorrhage in cases with an abnormal coagulation time is yet undetermined.

274. Fatal Asphyxia from Food-block.

H. Morgagni (December 15th, 1920) draws attention to two groups of cases of sudden death associated with meals: (1) Those in which, on unwonted exertion or sudden emotion after a full meal and with a stomach loaded with food, death occurs suddenly; these are usually associated with status lymphaticus or some disorder of the endocrine system, and as a rule treatment is impossible and useless. (2) Cases where death is due to the impaction of food in the pharynx, causing suffocation. Six such cases are recorded, and in only one was the cause recognized, and although the man was supposed to be dead when seen by the doctor, the idea arose in his mind to put his finger down the throat, when he pulled out a mass of food, and after respiratory exercises were started the man recovered. The suspicion of food impaction being the cause arose from the observation that on trying artificial respiration no air was found to enter, and on examining the pharynx the mass of food was discovered. If this possibility were thought of in similar cases some lives might be saved.

275. Experiments on Temporary Exclusion of One Kidney.

MIN AZZINI (*La Clin. Chirurg.*, May-June, 1920) has carried out a series (75) of operations on thirty-three dogs—excluding the ureter for about half an hour and measuring the urea excreted by the other kidney before, during, and after the exclusion. The author found that compression of the upper half of the ureter either has no influence on the function of the other kidney or acts as a stimulus to the contralateral organ. Exceptionally the renal activity may be lessened. But when the lower half of the ureter is compressed, the activity of the other kidney is always lessened, and in some cases if the ureter was compressed near the bladder, anuria resulted. From these experiments and a study of others, the author suggests that temporary closure of the ureter near the kidney may be useful as a preliminary stage to nephrectomy in those cases in which it has not been possible to get the urine of the two kidneys separately.

276. Division of the Superior Laryngeal Nerve in Laryngeal Phthisis.

MAYER (*Wien. Klin. Woch.*, January 6th, 1921) has carried out division of the superior laryngeal nerve on both sides for relief of dysphagia in ten cases of advanced laryngeal tuberculosis in which all other methods had failed. The operation in each case was performed under local anaesthesia. The result in most cases was very good. In two cases who survived for a considerable time there was a distinct increase of weight directly after the operation, and in a larger number the weight, which had hitherto been rapidly falling, remained constant. Most of the cases, however, survived the operation only a short time, the period of survival ranging from fourteen days to four months. In two the operation was not successful, as, in spite of complete division of the nerves, the dysphagia persisted, this being obviously due to the ulceration extending beyond the distribution of the superior

laryngeal nerve. Mayer's general impression of the operation is that it is more efficacious than the injection of the superior laryngeal nerve with alcohol, as recommended by Hofmann.

OBSTETRICS AND GYNAECOLOGY.

277. Varicose Veins of Female Pelvis.

EMGE (*Surg., Gyn., and Obstet.*, February, 1921) states that varicose veins of the pelvis are always acquired, and that while intestinal ptosis, habitual constipation, and prolonged menses may all produce them, pregnancy is the most important factor. The symptomatology centres round the pains the patient has complained of, which, beginning with a definite time, have appeared either bilaterally or unilaterally, usually on the left side, of a dull deep aching character, deep down in the abdomen, growing worse on long standing, and relieved quickly when the patient assumes the recumbent position. Other symptoms, such as constipation, leucorrhoea, backache, gastric disturbances, are not definite. If the patient is examined in the recumbent position the varicose veins are not palpable, and the diagnosis should be made by recto-vaginal examination in the recumbent alternating with the sitting position, the patient dropping her legs and raising the upper part of the body. In regard to treatment, the patient should keep off her feet as much as possible, and sexual excitement should be prohibited. Hot douches are of no benefit, but slow lukewarm douches with 2 to 3 per cent. menthol and 5 per cent. alum, will produce a pleasant cooling effect; 10 per cent. ichthyol vaginal suppositories, every night over two to three months, undoubtedly help. When the veins are so distended that one cannot suppose they can return to normal, operative procedures must be considered, and Emge says that resection of the veins is unnecessary, but that a high suspension of the uterus with a shortening of the utero-sacral ligaments offer the best means of symptomatic cure, with a possibility of a permanent anatomical regulation.

278. An Unusual Case of Galactorrhoea.

LUZZATTI (*J. Polyclinico, Sez. Prat.*, December 13th, 1920) records the case of a primipara who, in the fourth month of pregnancy, developed a profuse discharge from the nipples, the fluid having the characters of colostrum. The discharge caused irritation of the nipple and surrounding region with the formation of superficial fissures. The galactorrhoea continued during pregnancy and after the birth of the child, and was so profuse that in twenty-four hours more than two litres of milk could have been collected. By the fourth month of lactation the continued drain on her system gave rise to prostration, headache, and persistent dorso-lumbar pain. Sedative and astringent ointments were applied to the nipples, and when the fissures had healed the galactorrhoea ceased, after it had lasted for ten months.

279. Puerperal Thrombosis of the Vagina.

CHARBONNEL and FAYREAU (*Gaz. hebdo. des Sci. Méd. de Bordeaux*, January 30th, 1921) state that puerperal thrombosis is an unusual occurrence, being met with in only one out of 3,000 deliveries, and that it is extremely rare for it to become infected. According to Champeau, only 18 cases of thrombosis occurred among 54,000 women delivered in Professor Pinard's clinic, and in none of these 18 cases did infection take place. The writers record a case of puerperal thrombosis of the vaginal wall in a primipara in which infection occurred forty days after delivery. It was uncertain whether the infection was caused by a vaginal erosion, by the lymph or the blood stream, as the patient had a slight attack of mastitis.

280. Diagnosis of Foetal Hydrops Universalis.

KAFKA (*Zentralbl. f. Gynäk.*, November 20th, 1920) records a case of protracted labour in a multipara who gave birth to a child showing ascites and oedema of the extremities. The foetal heart sounds had been audible with special clearness in all parts of the enlarged uterus, and the author suggests that this finding may be of significance in the differential diagnosis from hydramnios—a condition in which the heart sounds are relatively indistinct.

281. Injections of Milk in Puerperal Infections

BIANCHI (*Riv. Med.*, November 6th, 1920) reports favourably of the treatment of puerperal infections by injections (mostly intramuscular) of milk. In 16 cases the milk was

injected as a prophylactic and in 57 as a curative agent. The results were as good as those previously noticed after injection of specific serums, and in the author's view were sufficiently encouraging to warrant further trial. Cow's milk was used and given in doses of 5 c.cm. to 20 c.cm. either every day or on alternate days. Usually three injections were given, sometimes five. The effect on the blood was to produce an initial leucopenia, followed by hyperleucocytosis.

PATHOLOGY.

282. Complement Deviation in Surgical Tuberculosis.

MOZER and FRIED (*C. R. Soc. Biologie*, December 18th, 1920) report on the results of the complement fixation reaction with Besredka's antigen in 689 cases in the seaside hospital at Berck. These comprised 173 cases of Pott's disease, 136 cases of coxalgia, 83 white swellings of the knee, 105 other tuberculous osteo-articular lesions, 44 cases of tuberculous glands, 105 rachitisms, 16 cases of congenital syphilis, and 27 others of non-tuberculous nature. In Pott's disease of under three years' duration 77 per cent. gave positive results, and of those of longer duration 94 per cent. were positive; when fistulae were present the percentage of positive results fell to 26. In the coxalgias under three years' duration 75 per cent., over three years 28 per cent., and where fistulae existed 24 per cent., were positive. In white swellings of the knee of less than two years' duration 76 per cent., and over that time 36 per cent., were positive, whilst the fistulous cases gave successful reactions in 14 per cent. In other articular tuberculous lesions 70 per cent. were positive when the disease had existed for less than two years, and 34 per cent. when they were long-standing. In tuberculous adenitis the reaction was positive in 36 per cent. In all the tuberculous cases, with very rare exceptions, the cuti-reaction with tuberculin was positive. In the pure rachitisms 7.5 per cent. gave positive complement deviation results; in the non-tuberculous cases of hereditary syphilis 50 per cent. gave positive reactions with the antigen; and in the various other non-tuberculous diseases only 2 were positive amongst the 27. Two striking results stand out: the percentage of positive results is much higher in cases of developing tuberculosis than in those undergoing cure; and the formation of fistulae corresponds with a feeble percentage of positive reactions.

283. Eosinophilia in Scabies.

HAYMAN and FAY (*Arch. Derm. and Syph.*, January, 1921) examined the blood of 55 scabies patients, varying in age from 3 to 30 years. The largest number of eosinophiles found was 15 per cent. and the smallest 1 per cent., with an average of 5.5 per cent. Thirty-two cases (58 per cent.) showed 5 per cent. or more of eosinophiles, whilst twenty (36.6 per cent.) showed 7 per cent. or more. The higher percentages came from the more extensive infestations, and the low or normal counts either from very recent cases in which symptoms had been noted for only two or three days, or else from slight infestations. The presence of pustules did not seem to be a factor. The eosinophilia increased with the extent of the disease and disappeared promptly as the disease was cured. Observations were made in order to find if, in addition to the blood eosinophilia, there was a local eosinophilia in the neighbourhood of the lesions, but no important difference was found.

284. Osteitis Mastoideo-zygomatice.

LUND (*Hospitalstidende*, January 5th, 1921) discusses the pathology and frequency of otogenic subperiosteal abscess in the temporal region. In a few cases an abscess in this position can be traced to inflammation of the cancellus tissue of the root of the zygomatic process. The author records two cases illustrating this comparatively rare condition. Although there was disease of the mastoid process in both cases, the inflammation of the root of the zygomatic process did not coincide with that of the mastoid process; indeed, in one case there was an interval of almost a year between the operation for mastoid disease and the development of an abscess above the external ear. In both cases the pre-existing disease of the middle ear and tympanum had apparently cleared up altogether. But the condition should still be regarded as a propagation of an inflammatory reaction from the mastoid process and middle ear upwards to the zygomatic process. The signs were swelling in front of the ear and in the temporal region, and in one case trismus, and in the other case pain on mastication.

285. Changes in the Heart and Circulation due to Muscular Exercise.

BARLOCCO (*Rif. Med.*, October 30th, 1920). as the result of a series of observations, finds that the normal subject after moderate exercise shows a slight reduction in the size of the heart, as well as an acceleration of pulse and increase of systolic blood pressure, both of which quickly regain their normal level. In the patient with compensated cardiac lesion there may be either a similar reaction or some increase in the cardiac diameters and changes in the pulse and pressure such as are seen in the early stages of the disturbed vascular equilibrium. In the neurotic vagotonic cardiac subject, after moderate exercises, the cardiac and pulse changes may be the reverse of what occurs in the normal subject. In the neurotic cardiac patient who suffers from changes in the sympathetic system, either no change or some reduction in the cardiac size was noted. After hypodermic injection of adrenalin a slight increase in cardiac volume and in systolic and diastolic pressure was found to occur. If the knee was flexed twenty times during the adrenalin period a reduction of the cardiac diameter could be well seen. In the vagotonic subject no increase in cardiac volume was observed after injecting adrenalin: in the sympathicotonic a marked increase in systolic and diminution of diastolic pressure was noticed. After hypodermic administration of 0.01 gram pilocarpin, diminished pulse rate and systolic pressure, increased cardiac volume, and great difficulty in performing exercises were noted in the vagotonic; the reverse occurred in the sympathicotonic subject.

286. The Blood Pressure and Oedema in Hemiplegia.

MIRALLIÉ (*Bull. et Mém. Soc. Méd. des Hôp. de Paris*, July 1st, 1920) examined the blood pressure, using Pachon's instrument, in twenty cases of hemiplegia, sixteen of which were in women and four in men; the duration of the hemiplegia ranged from seven months to thirty years. As a general rule he found that the maximum tension was lowest on the paralysed side both in the upper and lower limbs, whereas the minimum tension was practically equal on both sides. From a study of three cases the writer concludes that oedema, whether early or late in hemiplegia, is due to cardio-renal inefficiency. Hemiplegia, by disturbing the blood pressure, produces a slowing of the local circulation, and gives rise to the immediate appearance of a hitherto potential oedema. The existence of a purely nervous oedema has yet to be proved.

287. Glycosuria in Infants.

Using the test of Benedict and Osterberg, GREENTHAL (*Amer. Journ. of L.S. of Children*, December, 1920) has found that the urine of all normal infants contains a determinable amount of reducing sugar; the amount of sugar excreted is proportional to that ingested. As the amount of sugar in the diet is increased the total sugar in the urine becomes greater, but the increase chiefly concerns the fermentable portion. When the intake of sugar is constant, sugar excretion both as regards the fermentable and non-fermentable portion, is also fairly constant. In infants receiving from 6 to 7.5 per cent. of sugar the total sugar excretion in the urine ranged from 100 to 400 mg. a day. Benedict, Osterberg, and Neuwirth found that on an ordinary diet adults excrete from 600 to 1,200 mg. of sugar a day.

288. Provocative Reactions in the Cerebro-spinal Fluid in Neuro-syphilis.

SOLOMON and KLAUDER (*Arch. Derm. and Syph.*, December, 1920) give case-histories to show that after treatment by arsphenamin the cerebro-spinal fluid, which was negative before treatment, may become positive in all routine tests, or a weakly reacting fluid may become much stronger. This "provocative reaction" may be evoked by intravenous or intraspinal injection of arsphenamin; it is comparable to the provocation of the Wassermann reaction in the blood and to the Herxheimer reaction (production of neuro-recurrences). The provocative reaction is shown to occur in both the ventricular and spinal fluids. It is not a frequent phenomenon, and patients with vascular neuro-syphilis with negative cerebro-spinal fluids may not react in this manner; by the reactions, however, diagnosis may occasionally be made clear in obscure cases. In none of the cases in this series was the provocative reaction obtained with the blood serum. Despite the increase in the strength of the spinal fluid reactions, clinical improvement may result, and continued treatment may again produce a negative fluid.

EPITOME OF CURRENT MEDICAL LITERATURE.

MEDICINE.

289. Acute and Tuberculous Meningitis.

MORQUIO, of Montevideo, Uruguay (*Journ. of Nerv. and Ment. Dis.*, January, 1921), discusses the experience gained in over 100 cases of meningitis. The author divides them up from a clinical standpoint into three groups: (1) Acute meningitis; (2) tuberculous meningitis; (3) meningeal reactions. The acute forms include cerebro-spinal meningitis, pneumococcal meningitis, and infections by the streptococcus and staphylococcus, etc. The meningitis of cerebro-spinal origin ran its usual course, and responded to serotherapy. The pneumococcal cases were characterized by sudden onset, well-marked meningeal symptoms, and frequent fatal results. While generally primary, it sometimes followed pneumonia. The tuberculous form occurred in children from 4 months to 15 years of age. The signs differed according to the age of the child. In breast-fed infants the author noted rapid evolution, with convulsions and coma. Older children showed more irritative signs, spasmodic contractions, delirium, etc. Tuberculous infections, again, were mostly primary, but did occur secondary to tuberculous disease of the lung, peritonum, or joints. The disease not infrequently followed enteric in the author's cases. Tuberculous meningitis in children may be simulated by other conditions. Mumps may produce vague meningeal signs, as may also otitis media, and more rarely congenital syphilis. Rigidity of the neck and Kernig's sign, according to the author, are observed in the early stages of pneumonia, enteric, and severe influenza. The signs may lead to lumbar puncture being performed, when the observer will be surprised to find an increase of tension in the cerebro-spinal fluid. It is clear in appearance, and no chemical or cell changes are found. The author insists on lumbar puncture as a routine in all cases of meningitis. He has found that examination often shows unexpected results. For example, in cerebro-spinal meningitis the fluid may be transparent with lymphocytes from the outset, but, in general, only becomes so when there is improvement. In such a case it is possible to withdraw purulent fluid containing polymuclear cells on one day, and on the next to find the fluid clear and containing lymphocytes. Bacteriological examination is necessary to solve all doubts.

290. Antipneumococcus Serum.

COLE (*Journ. Amer. Med. Assoc.*, January 8th, 1921) urges that in lobar pneumonia the type of pneumococcus concerned should be determined before using an immune serum, which can only be of therapeutic value if it has been prepared by immunizing horses against the particular type of pneumococcus. The serum should be of such potency that 0.2 c.c.m. will regularly protect a mouse against 0.1 c.c.m. of a culture of such virulence that 0.000001 c.c.m. would kill a non-immunized mouse in forty-eight hours. Treatment should be started as early as possible after the type has been determined. The first dose of serum should be from 90 to 100 c.c.m. intravenously at body temperature, and repeated every eight hours until the fall of temperature and general amelioration of symptoms. An average case may require from 200 to 300 c.c.m., but in a severe late case 1,000 c.c.m. may be needed. After use of the serum the blood becomes sterile, local lesions are arrested, and mortality is reduced. The first part of the first intravenous injection should be given very slowly as a desensitizing measure, but if there is much hypersensitiveness it may be necessary to commence with small doses subcutaneously, and the physician should be prepared to inject 0.6 c.c.m. (10 minims) of 1 in 1,000 suprarenal extract should severe anaphylactic symptoms occur.

291. Early Treatment in Tuberculosis.

SHIGA (*International Journ. of Public Health*, January February, 1921) urges protective inoculation for tuberculosis before the appearance of symptoms and in cases in which the diagnosis is uncertain but which may be regarded as possibly infected. Von Pirquet's reaction is a necessary preliminary, not only to show whether or not there is a tuberculous infection, but also to show its intensity, and a marked cutaneous reaction is a favourable indication for vaccine therapy. Before commencing treatment the temperature should be noted for a week in order to determine the size of the first doses, since in febrile

cases caution is needed whether for treatment or prevention. With a widely positive von Pirquet's reaction treatment can be applied at once and will not last long. Injections are given once a week and last about four months. About 300 ambulant cases have been treated with the author's sera vaccine, 20 of whom received protective inoculation. The results have been most encouraging, the general condition having improved and the weight increased, while such symptoms as slight fever and splenic breath sounds have entirely disappeared.

292. Congenital Malformation of the Mitral Valve.

OWING to the rarity of congenital malformations of the mitral valve CASTELLI (*Il Morgagni*, December 31st, 1920) publishes the following case. A man, aged 65, was admitted into hospital for cancer of the stomach, and at the necropsy a definite malformation of the mitral valve was discovered. Before describing his case the author briefly refers to 18 more or less similar cases reported by various writers. On examining the heart the left ventricle was thickened, there was slight adhesion between the aortic cusps and there was a small fenestra in the right anterior aortic cusp; the left atrio-ventricular orifice was narrowed. The aortic and lateral cusps of the mitral valve were partly inserted to the upper part of the interventricular septum, which presented an aneurysmal dilatation towards the right ventricle. No other malformations were present in the body. There was some evidence of old tubercle in the right apex. A photographic reproduction of the malformation shows the irregularity of the mitral valve very clearly and emphasizes its difference from most of the other cases recorded. Discussing the genesis of congenital heart disease and this case in particular, the author supposes that the anomalous insertion of the free margins of the mitral valve came about by a process of fusion of the chordae tendineae into the muscle of the septum before its closure. Probably on this congenital malformation recurrent inflammatory attacks were superposed at various periods both intra- and extra uterine. Good cardiac compensation was maintained, so that there was no evidence of disturbance of the circulation.

293. Fatal Borax Poisoning.

IN a case cited by POTTER (*Journ. Amer. Med. Assoc.*, February 5th, 1921) the patient took what he thought was a saline cathartic. Within fifteen minutes he was seized with violent epigastric cramps, accompanied by attacks of retching and vomiting, coming on at from five to ten minute intervals. At five-minute intervals he would cry out that he was strangling or choking. The lips were slightly cyanotic. At intervals of a few minutes he cried out with pain in the epigastrium, and then immediately after he would grasp his throat and complain of difficulty in swallowing, of choking and strangling. Notwithstanding active hypodermic stimulation (½ grain of strychnine and 2 c.c.m. of camphor in oil) he died in one of these paroxysms soon afterward. There was no lead line on the gums or other symptoms present or past to suggest lead colic. Chemical analysis of the contents of the stomach demonstrated the presence of 1½ oz. of borax. At the coroner's inquest it was shown that the deceased's mother-in-law, about 80 years of age, had filled the empty saline bottle with borax without informing the family or changing the label, and that it had been placed on the medicine shelf by another member of the family who thought it was a bottle of saline laxative.

294. Influenza Statistics.

IN a statistical analysis of 648 cases of influenza admitted to his hospital in the first quarter of 1920, BUCHHOLTZ (*Veget. for Lungen*, February 3rd, 1921) shows that reinfection ran a milder course than the first infection. Thus, among the patients who recovered, 18 per cent. had previously suffered from influenza, whereas this was the case only in 6 per cent. of the patients who died from influenza. The author admits, however, that these figures are not conclusive proof of immunity conferred by a first attack. In 367 cases the disease was complicated by pneumonia, and all the 162 deaths belonged to this group of cases. Only in 6 per cent. was the influenza uncomplicated. Epistaxis occurred in 23 per cent. of the total, a sore throat in 9 per cent., laryngitis and tracheitis in barely 5 per cent., and otitis media in 2.5 per cent. (23 cases). In 43 per cent. of the cases without pneumonia there were signs of

bronchitis; among these cases there were possibly some with bronchopneumonia, for the diagnosis of pneumonia was made only when the physical signs were definitely positive. In about 30 per cent. of the cases with pneumonia the sputum was haemorrhagic. Measurements of the blood pressure showed that a low blood pressure—that is, 90 mm. or less—was of bad prognostic significance when associated with pneumonia. The subsequent course of the cases of pneumonia which did not terminate fatally was usually uneventful, but in two cases chronic fibrosis and bronchiectasis supervened. The degree of cyanosis was of great prognostic value; 80 per cent. of the patients who died were markedly cyanosed, whereas this was the case only in 24 per cent. of the cases of pneumonia terminating in recovery.

295. Thrombosis of the Splenic Vein.

ACCORDING TO BAIIS (*Ned. l. Tijdschr. v. Geneesk.*, February 5th, 1921), who records a fatal case in an anaemic woman in whom splenic thrombosis was rapidly followed by portal thrombosis and infarction of a large part of the jejunum and ileum, 28 cases of infarction of the spleen were collected in 1918 by Nuzum, who recorded also 4 of his own. In only 7 of these 32 cases, however, was the cause of the infarction thrombosis of the splenic vein. In all the other cases the cause was obstruction of the splenic vein or artery by a malignant growth, embolism of the splenic artery, or torsion of the pedicle of a displaced spleen. Little can be said with regard to the clinical symptoms of infarction of the spleen, but pronounced tenderness and pain in an enlarged spleen occurring in the course of a chronic disease are suggestive. Some cases have been described by Ewald in which fatal haematemesis has occurred. In Bais's case the enlarged veins found *post mortem* in the stomach wall pointed to the likelihood of this event. Nuzum regards the frequent occurrence of fever as of diagnostic significance, but Bais thinks that the fever can in most cases be explained by the primary disease.

296. The Treatment of Cerebro-spinal Syphilis.

SCHRÖDER (*Hospitalstidende*, November 3rd, 1920) points out that at one time the opinion was generally held that the influence of potassium iodide and mercury was almost negligible in syphilis of the cerebro-spinal system, notably tabes and dementia paralytica. During 1919, at his hospital, he systematically treated every case of cerebro-spinal syphilis with potassium iodide, mercury, and neosalvarsan. Repeated examinations of the cerebro-spinal fluid showed that the amount of globulin and albumin could be reduced to normal even in the case of dementia paralytica. As a rule, but not invariably, changes in the clinical picture coincided with changes in the composition of the cerebro-spinal fluid; this coincidence was least marked in cases of dementia paralytica. The author concludes that vigorous and prolonged specific treatment of syphilis of the nervous system may not only arrest the disease, but even effect some improvement; the results of this treatment in dementia paralytica are very uncertain, but not wholly disappointing.

297. Treatment of Intracranial Haemorrhage in the Newborn.

VAGLIO (*La Pediatria*, January 1st, 1921), who records an illustrative case in an infant aged 3 days, draws attention to the efficacy of lumbar puncture in intracranial haemorrhage in the newborn. In his case the child—who was born in a slightly asphyxial condition—forty-eight hours after birth, without appreciable cause, developed a series of convulsions, which increased in frequency and intensity and involved various muscles of the limbs and trunk. After removal of 10 c.cm. of uniformly blood-stained cerebro-spinal fluid under considerable pressure the convulsions greatly diminished in frequency and intensity. The following morning there were still a few convulsions, but they ceased entirely in the afternoon, and subsequent recovery was uneventful.

298. Treatment of Anaemia by Nucleinate of Manganese.

LÉMOINE (*Bull. Soc. de Théor.*, November 10th, 1920) alludes to the work of Hannon and Pétrequin on the therapeutical value of manganese; both of these writers had emphasized its value as a tonic, and Pétrequin had even drawn a clinical distinction between chlorosis due to lack of iron, and that due to lack of manganese. Lemoine has employed nucleinate of manganese in cases of anaemia and debility due to acute infectious or neurasthenia, and has observed subsequent regeneration of the red cells and increase of haemoglobin.

SURGERY.

299. Compression Fractures of Vertebrae.

BAKER (*Surg., Gyn., and Obstet.*, October, 1920) describes seven cases of compression fractures of the vertebral bodies with delayed symptoms—the so-called "Kummel's disease." The characteristic history is one of injury to the back with more or less local pain and temporary incapacity. There is no injury to the cord, and the absence of positive neurological findings leads the medical attendant to put the possibility of vertebral fracture out of court. Sometimes the patient may be up and about within two weeks, and the true diagnosis may not be made for periods of from three months to two years later. The injury is usually a fall, and the site of the compression fracture most often is in one of the lower thoracic or lumbar vertebrae. Pain is apt to be persistent, and subsequent examination will as a rule reveal a distinct kyphosis, or local angulation of the spine, with musculo-spasm. Careful radiography displays a compressed vertebra. Positive diagnosis can only be arrived at through the x rays, and it is most important that these should be clear and sharp. The radiography of the spine is not yet as certain as the clinician might wish. Often a skiagram taken at the time of the injury has disclosed no spinal abnormality, whilst later plates show an incontestable fracture. It is not quite fair to blame the radiographer in all cases for this, for the bony changes probably develop later. In four of Baker's seven cases the initial roentgenograms were negative for bony lesion, and no early treatment was instituted. The treatment is the same as for ordinary fracture of the spine. Late nervous changes must be very rare and generally due to callus formation.

300. Chronic Intestinal Stasis.

CAUCCI (*La Clin. Chirurg.*, May, 1920), in a long article on this condition, synthesizes recent knowledge on the subject and records three cases operated upon successfully by him. Intestinal stasis is three times as common in women as in men—mostly between the ages of 15 and 45 years, never after 55. The cardinal symptoms are habitual obstinate constipation (with occasional secondary colitic diarrhoea), pain, and symptoms of chronic faecal auto-intoxication. Acute intestinal obstruction may occur and "false" appendicitis. Marked cachexia, suggesting possible malignant disease, is common. The anatomical changes causing the stasis may be grouped as deformities of the gut, anomalous situation, and adhesions, and the author describes the different varieties, minutely dividing the intestinal tract into three sections—(1) ileo-caecal ascending colon and hepatic flexure, (2) transverse colon and splenic flexure, and (3) descending colon and sigmoid—and discusses the special abnormalities commonly seen in each section. He compares the slow establishment of intestinal stasis to the similar onset of venous stasis from failure of the myocardium. A change occurs in the relation between the muscular power of the intestine and the resistance opposed to the passage of the faeces. The differential diagnosis is discussed and most of the usual difficulties mentioned. He thinks small incisions for appendix operations are a mistake, as one ought to be prepared to examine more than the appendix only in a laparotomy. In operative treatment five possibilities are discussed: (1) plastic fixation of the bowel (now abandoned), (2) destruction of adhesions, (3) appendicostomy, (4) intestinal anastomosis, (5) colectomy—with a preference for a combination of (3) and (4). A bibliography of nearly 300 references is appended.

301. Surgical Complications of Typhus.

MICHL (*Wien. klin. Woch.*, December 23rd, 1920) states that parotitis is one of the most frequent complications of typhus, and is usually due to neglect of oral hygiene and toxic damage to the gland. It may occur on one or both sides, usually at the time when a fall of temperature is expected. Of nine of Michl's cases four were bilateral. The second most frequent complication is gangrene, which chiefly attacks the lower extremities. Gangrene of the toes often occurs on both sides. Not infrequently the gangrene extends to the legs, either on both sides or to the left leg especially. Bedsores only rarely occur in cases which have been properly nursed. On the other hand, abscesses of the skin and subcutaneous tissue requiring free incisions are frequent, and are very slow in healing. Bronchitis, which is the rule in typhus, often becomes transformed into pneumonia, which leads to pulmonary abscess or gangrene, usually with fatal termination. The pneumonia is often accompanied by a

serous or purulent pleural effusion which requires extensive rib resection. Suppurative otitis media is another complication, which usually makes its appearance in convalescence, requiring paracentesis or, later, mastoid operation.

302. Adenofibromata of the Breast.

ACCORDING to POPOVICI (*Ciujul Med.*, November 1st, 1920), who records an illustrative case in a woman, aged 28, benign tumours of the breast are rare. Of 100 mammary tumours observed by Billroth, 82 were epitheliomata and the remaining 18 benign tumours. Braquehaye, Couric, Lecône, and Lenormant describe two varieties of mammary adenofibromata—a diffuse and a circumscribed form. Diffuse adenofibromata form large tumours, which involve the whole breast. Circumscribed adenofibromata are at first round or ovoid, but later become nodular or lobulated. Their site of predilection is the periphery of the breast. Adenofibromata are most frequent between the ages of 20 and 30. The earliest age at which they have been observed is 9 years and the oldest 65. Their evolution is insidious and painless. As the tumour grows the breast tends to become pedunculated, and to fall down over the abdomen, as far as the umbilicus, pubes, or even lower. The tumours may reach a considerable size. In Popovici's case the growth was 64 cm. in circumference and 2 kilos 200 grams in weight. Binaud and Braquehaye described a case 65 cm. in circumference and 3 kilos 250 grams in weight. The treatment of these tumours is surgical. When the growth is diffuse, or as large as in Popovici's case, amputation of the breast is required, but when it is small, mobile, and encapsulated without infiltration, partial extirpation only is needed.

303. Anterior Bow-legs.

BLANCHARD (*Journ. of Orthopaedic Surg.*, January, 1921) urges osteoclasts as against osteotomy in the treatment of bow-legs, but it should not be undertaken until, under rachitic treatment, the bones have eburnated and become firm and hard. Prior to operation the patient is put upon a rachitic diet of orange juice, boiled fat bacon, cereals with cream, rich milk, eggs, scraped or pressed beef juice, bread with much butter, phosphorized cod-liver oil, vegetables, and no tea or coffee. The frequent occurrence of non-union after osteotomy is due to the interruption of bone continuity by the chisel, and the filling up of the open space by extraneous material. In the correction of deformities near joints a fear has been expressed that the osteoclast may slip over the end of the bone and injure the joint, but in twenty years' experience with the Gratian osteoclast the author has never seen a joint endangered. Slow osteoclasts is dangerous, and not more than eight seconds should be occupied in fracturing a bone in the osteoclast. The effect on the mental condition is a marked end-result of such operations, the dejected pre-operation look giving place to a self-confident poise after cure.

304. Breast Enlargement after Prostatectomy.

KONDOLÉON of Athens (*Zentralbl. f. Chir.*, September, 1920) reports two cases in which prostatectomy was followed by enlargement of the mammary glands. In the first case shortly after operation the right breast became hard and swollen. A year later the swelling had disappeared. In the second case both breasts swelled three and four months respectively after prostatectomy. Kondoléon suggests that the prostate may secrete a substance inhibitory to male mammary development; the removal of the prostate would naturally remove this controlling influence. He goes so far as to hazard the opinion that this breast enlargement favours the view that in doing a prostatectomy we remove functioning prostatic tissue and not a sterile adenoma.

305. Pedunculated Cancer of the Larynx.

ACCORDING to BURGER (*Nederl. Tijdschr. v. Geneesk.*, January 29th, 1921), who records a case in a man aged 72, pedunculated cancer of the larynx is very rare, since he has found only two similar cases, reported by Flecker, on record. The clinical picture was that of a benign tumour, as the growth was round, smooth, pale, and freely movable, and it was only on microscopical examination that it was found to be carcinoma. The malignancy of a tumour arising as it did in this case from the aryepiglottic fold, as compared with the relative benignity of cancer of the vocal cords, confirms the rule of the old French laryngologist Krishaber, who drew attention to the difference between the relatively malignant cancers of the entrance to the larynx as compared with the relatively benign cancers within the larynx. It is therefore neces-

sary in the case of a movable pedunculated and apparently benign tumour of the entrance to the larynx not to exclude the possibility of cancer, at least in persons of a certain age.

OBSTETRICS AND GYNAECOLOGY.

306. Retrospect of Four Thousand Obstetric Cases.

PORTER MATHIAS (*South African Med. Record*, December 24th, 1920) states, in a retrospect of four thousand obstetric cases, that his mortality was 1 per 1,000, and gives practical hints ranging over the whole scope of obstetrics. In discussing lacerations of the perineum, he suggests that with a more frequent use of forceps the percentage of cases with lacerations has diminished. The chief point he mentions in the management of occipito-posterior presentations is the early manual rotation of the head. In dealing with cases of breech presentation, he emphasizes the importance of doing external version in the eighth month, if necessary using an anaesthetic. The author's remarks on the management of cases with delay in the first stage are interesting. He divides such cases into four groups: (1) where the pains are infrequent and feeble; (2) where there is premature rupture of membranes; (3) rare cases of continuous contraction of uterus before the membranes have been ruptured—due generally to abnormal presentations, such as transverse. These were all cured by partial anaesthesia and rectification of position. The fourth group consisted of cases with spasm of the cervix at the same time as the upper segment of the uterus contracted. He treated such cases with pituitrin hypodermically, and suggests that this drug has a dilator effect of the lower segment under anaesthesia as well as causing contractions. He states very emphatically that he never gives pituitrin in labour except under anaesthesia. On the question of retained membranes he inclines to the accepted idea that it is better not to remove them manually.

307. Ectopic Gestation.

GRAD (*Brit. Journ. of Obstet. and Gyn.*, January, 1921) analyses fifty cases of ectopic gestation, dividing them into four groups: (1) Ectopic gestation with negligible haemorrhage, (2) with moderate haemorrhage, (3) with severe haemorrhage, and (4) with fatal haemorrhage. In the 50 cases presented, 37 were of the first group, 4 of the second, 7 of the third, and 2 were fatal. As regards diagnosis, in the first group only 25 per cent., and in the second group 50 per cent., were diagnosed correctly, but the other more serious cases were diagnosed correctly. Dealing with symptomatology, in the first group pain was the prominent symptom in 26 cases, vaginal bleeding in 11; in the second group pain was a prominent symptom in 3 and bleeding in one; in the third group the prominent symptom was collapse, and in the fourth group syncope. Patients in the third group have a thready pulse but a clear mind, and in the fourth group the mind is dulled and the pulse at best shows only an occasional beat. In 48 cases the right tube was involved twenty-two times and the left tube twenty-four times, showing that gestation occurs with the same frequency in both Fallopian tubes; in 2 cases the pregnancy was interstitial, once on the right and once on the left side. Grad considers that operation should be performed in every case, but in the more serious cases of the third and fourth groups the patients require immediate treatment before transportation to the hospital, and he advises infusing gum glucose or saline and gum solution intravenously at once before removal, until a donor can be obtained for a blood transfusion, in addition to the other methods for counteracting shock. The operation in these cases should have for its aim the control of the bleeding and nothing else, and should be done as rapidly as possible.

308. Radiation Treatment of Carcinoma of Uterus.

BELEBE (*Journ. de rad. et d'élect.*, January, 1921), reviews critically the radiation treatment of carcinoma of the uterus, as employed in the gynaecological clinic of Erlangen. The method of dosage is the same as that employed by Villard and Krönig—namely, to measure the ionization currents produced in a small air chamber by the action of the rays. This air chamber can be placed in the vagina. The rays used are very penetrating, and are obtained by a 35 to 40 cm. spark gap with a filter of 0.5 mm. of zinc on 11 mm. of aluminium. The doses have been carefully worked out, and are called eutaneous dose, castration dose (that is, sufficient to destroy the cells in a healthy ovary), sarcoma dose and carcinoma dose (that is,

lethal doses for sarcoma or carcinoma cells). Having worked out these doses, the next problem which presented itself was to estimate the actual dose which penetrates as far as the uterus. First, a wooden box filled with water was used to represent the pelvis, and the dose was measured at various depths. At 10 cm. the dose was 20 per cent. of the superficial dose. Using the same size port of entry, and with the tube at the same distance, observations were carried out on the cadaver, and the dose exactly measured in the body of the uterus and in the cervical canal. A third method of checking the results was to use a black glass tube 2 metres long, one end of which was placed against the cervix and contained a fluorescent screen at an angle of 45 degrees. By these various methods it was found what the actual dose at the cervix was, corresponding to the different ports of entry. Three anterior and three posterior ports of entry were used, and in very fat women an extra-vulval port of entry was employed. This made the total dose at the cervix 110 per cent. of a cutaneous dose—that is to say, sufficient for a carcinoma lethal dose. Before treating a patient a certain amount of preparation must be done, the bowels and bladder completely emptied and the latter kept empty. The exact orientation of the tube is very important, and a tube localizer is used. The current is kept constant at 2.3 milliamperes. The total time taken for one application of the rays is about four hours, and the patient is generally given morphine and scopolamine. There are a certain number of risks involved by this treatment, such as nausea and vomiting for many hours. In addition to such minor troubles there is sometimes great diminution in the white corpuscles, and a second dose should not be given for at least six weeks. Combined treatment of radium and x-rays was tried in a number of cases, but the authors did not give any definite opinion as to their results. In conclusion, Bécère points out that although it is much too early to express a definite opinion on the value of this new x-ray technique as employed in Erlangen, yet the results so far obtained in operable cases promise to be much better than any operative measures. Of 24 cases treated, in 23 the tumour disappeared entirely.

309. Acquired Vaginal Stricture.

PROBASTA (*Rev. Españ. de Med. y Ciruj.*, October, 1920) records the case of a woman, aged 24, who complained of menorrhagia and metrorrhagia; about 4 cm. from the vulva there was a vaginal stricture admitting the passage of a fine probe only and extending upwards for about 3 cm., as shown by rectal examination. Cure was effected by repeated dilatation by means of bougies, tents, and manual stretching. The stricture appeared to date from a severe attack of vaginitis, which had persisted for one year during early infancy.

PATHOLOGY.

310. Histology of the Measles Exanthem.

ABRAMOFF (*C. R. Soc. Biologie*, January 22nd, 1921) finds that on the first day of the disease, though the skin appears perfectly normal to the naked eye, yet microscopic examination reveals there the first changes which make their appearance in the epithelium. Vacuolated nuclei are to be found in the deep layers of the epidermis. On the second day, whilst the skin still appears normal, the numbers of such vacuolated nuclei increase and certain modifications are produced in the protoplasm of the epithelial cells; the latter become vacuolated also. The nucleus is pushed to the periphery, assuming a crescentic form, and a clear vacuole completely occupies the cell. When the eruption appears these changes increase and attain their maximum in two or three days. The deeper parts of the Malpighian layer then contain very swollen altered cells, which stand out from the lower limit of the Malpighian layer and penetrate into the dermis. Gradually they become separated from the dermis, lose their nuclei, and are transformed into colourless masses. These masses form in the dermis strands or irregular collections which may attain considerable dimensions. From the fourth day after the commencement of the eruption they begin to be absorbed. They shrivel up and a round-cell infiltration occurs around them. Finally giant cells are formed which enclose these masses. The process then subsides, but its traces are perceptible for a long time. Even in the third week parts of the epithelial layer may still be atrophied and the Malpighian zone may be almost completely wanting. The changes in the dermis make their appearance later

than those of the epidermis, and consist in perivascular infiltrations clearly visible on the second day of the eruption, as well as the formation of the subepithelial cellular masses already mentioned, which may be looked upon as a sign of the absorption of the degenerated products of the epithelial layer. There is no very evident hyperaemia nor oedema of the dermis. Oedema can only be found in the deeper layers below the subcutaneous cellular tissue, especially around the muscles and the glands.

311. A Meningococcus Epidemic in Barracks.

THOMSEN and WULFF (*Hospitaltidende*, January 12th and 19th, 1921) have closely studied certain features of a small epidemic of meningococcus infection in a military school containing 275 men. After two men had fallen ill a search was made for "carriers" by a bacteriological examination of the nasopharynx of every soldier. Positive results were obtained in 31 cases, including the men who fell ill. Of this total, 16 showed Type A, with which 90 per cent. of all the cases of meningococcal sepsis in Denmark during the past two or three years have been identified. In 4 of these 16 cases the infection gave rise to symptoms of disease; in the remaining 12 there was no clinical reaction. Of the 16 cases of Type A, 15 belonged to one barrack, and only one to the adjacent barrack. Thus the early isolation of the infected cases in the first barrack would seem to have been effective in preventing further spread of the disease. In 15 cases the "carriers" harboured meningococci of comparatively benign character, differing in essentials from Type A. The barracks ran north and south; the east side was dark and damp, the west side was comparatively dry and sunny. On the east side there were 139 men, on the west side 136 men. But though the number of men was almost exactly equal on the two sides, there were 22 meningococcus-positive cases on the east side, as compared with only 9 on the west side. Of the "carriers" harbouring non-virulent meningococci, 12 were on the east side, and only 3 on the west. As the authors' diagrams show, the meningococcus-positive cases occurred more or less in groups, two or three adjoining beds being occupied by "carriers," while another series of adjoining beds would prove meningococcus-negative. The authors suggest that the comparatively high incidence of meningococcus infection on the dark and damp side of the barracks should be correlated with the devitalizing effect of these factors on the human organism.

312. Demonstration of *Spirochaeta pallida* in Tissues.

WARTHIN and STARRY (*Journ. Amer. Med. Assoc.*, January 22nd, 1921) present a method which they consider a great improvement on their first method, in that it possesses these advantages: (1) The time is much shortened, the entire procedure may be carried out in less than one hour after the sections have been mounted on cover-glasses; (2) the results are more certain. Spirochaetes have been demonstrated in tissues by this method when all others have given negative results. Tissues are fixed in neutral formaldehyde, embedded in paraffin. Sections are cut and mounted on cover-glasses with albumin fixative. The paraffin is removed with xylene, alcohol, water. Next the cover-glass is rinsed with the section in 2 per cent. silver nitrate; the wet section is covered with another perfectly clean cover-glass, so that they are held together by capillary attraction; then they are placed carefully in a bottle of 2 per cent. silver nitrate and placed in an incubator for from thirty minutes to one hour. They are removed from the silver nitrate and the cover-glasses separated. The cover-glass with the section is then placed in this reducing mixture:

Two per cent. silver nitrate solution	3 c.cm.
Warm glycerin	"	"	5 "
Warm 10 per cent. aqueous gelatine solution	"	"	5 "
Warm 1.5 per cent. agar suspension	"	"	5 "
Five per cent. aqueous hydroquinone solution	"	"	2 "

After the section is reduced, it is removed and rinsed in 5 per cent. sodium thiosulphate (hyposulphite) solution, rinsed in distilled water and mounted—absolute alcohol, xylene, balsam. The method is described in detail.

313. The Early Diagnosis of Cholera.

PAUSINI (*Rif. Med.*, November 20th, 1920), as the result of experiments on the early bacteriological diagnosis of cholera, concludes that the best results are obtained by strengthening the mixture in peptonized water for six to eighteen hours, followed by culture on Dieudonné blood agar for twenty-four hours. Microscopic examination of the stained culture is succeeded by the agglutination test; this may or may not be preceded by transplantation on to ordinary agar.

EPITOME OF CURRENT MEDICAL LITERATURE.

MEDICINE.

314. Treatment of Whooping-cough.

GENOÈSE (*Il Policlinico*, Sez. Prat., February 7th, 1921) states that treatment of whooping-cough by injections of ether was first employed by Andrain in 1914, who reported excellent results from its use in 14 cases. Identical results were subsequently obtained by Weill and Dufourt of Lyons, Renard of Saint Etienne, De Herripon of Lille, and Dalché, Variot, and Weil of Paris. Genoese employed the method in 20 cases, whose ages ranged from 6 months to 11 years. All had severe attacks, some of which were complicated by bronchopneumonia. The injections were given deep into the gluteal muscles. The doses employed were $\frac{1}{2}$ c.cm. every other day for infants under 1 year, 1 c.cm. for children from 1 to 3 years, and above 3 years 2 c.cm. No severe local reactions were observed in any case. Three to six injections were required according to the case, the duration of the treatment being from eight to ten days. Most of the patients came under treatment on the eighth to the tenth day, but several were in an advanced stage. The treatment, however, proved effective at every stage of the disease. In all the cases the cure was permanent, and there was no relapse. Genoese attributes the success of the remedy to the antiseptic action of the ether.

315. Digestion of Keloids, Cicatrices, and Buboec with Pepsin-Hydrochloric Acid

AHLSTWED (*Arch. of Derm. and Syph.*, February, 1921) describes experiments on keloids and scarring after burns, cicatrices, etc., with the intention of testing the possibility of digesting the fibrous tissue of these scars. The following solution was used: Pepsin 10 c.cm., hydrochloric acid 1 c.cm., phenol 1 c.cm., aq. dest. ad 200. Compresses of absorbent cotton soaked in this solution were applied and covered with impermeable material. The cosmetic effect on scarring after burns was excellent. These successes led to the use of the solution in persistent ulcer durum, especially in these obstinate cases in which the labia majora are changed into broad and hard masses of tissue. Cases of adenitis—for example, bubo—were treated by the same means, and showed a regression of the inflammation within two or three weeks without incision. In one case of double bubo one side was incised and iodoform glycerin applied, while the other was treated with the solution. The latter was completely absorbed before the wound on the other side had healed. The effect of the pepsin hydrochloric acid on infected glands can only be explained by the bactericidal power of the phenol plus hydrochloric acid, besides the digestion of the inflamed tissues by pepsin. Tuberculous glands, especially those of the throat and neck, can be treated by the same method.

316. Tuberculous Meningitis.

Il Morgagni (December 25th, 1920) says that tuberculous meningitis is always secondary to some lesion in the lungs, bones, genito-urinary apparatus, or lymphatic glands. Occasionally, especially when there is extensive pulmonary tuberculosis, symptoms of meningitis occur, and yet at the autopsy no meningitis is present. In these cases the meningitis is probably of a toxic nature, the organism being so saturated that it is not able to form tubercles, which are really one of Nature's defensive processes. If the cerebro-spinal fluid is examined some evidence of tubercle may be found. The only certain evidence is the presence of tubercle bacilli. X-ray examination is useful as showing the presence of generalized miliary tuberculosis. Increase in the number of lymphocytes in the cerebro-spinal fluid is a valuable but not pathognomonic sign, and the formation of a coagulum also points in the same direction. Augmentation of the albumin content also is suggestive of tubercle. Mandelbaum, with a modification of the fermentation test of Lenk and Pollard, affirms that he is able to differentiate between tuberculous and other forms of meningitis. In 73 cases examined the reaction was positive in 30, and in 28 of these the autopsy revealed definite tuberculous meningitis; the other two recovered. He says that if the reaction is negative one can safely exclude tubercle as the cause of the meningitis.

317. Serum Treatment of Acute Poliomyelitis.

AMOSS (*Journ. Amer. Med. Assoc.*, January 8th, 1921) urges the administration of serum as early as possible, since it is of doubtful value after the febrile period has passed. Seeing that the only available source of serum for treatment is from persons who have recovered from an attack of poliomyelitis, it should be collected and tested as soon as possible after an epidemic has appeared in a region, and while the needle is still *in situ* for lumbar puncture the fluid should be examined for cells and globulin, and warmed serum given through the same needle if the diagnosis is positive. After the intraspinal injection warmed serum is given intravenously, and both injections may be repeated in twenty-four hours if the temperature has not become normal. In the intraspinal administration the amount of serum injected varies according to the amount of fluid withdrawn and the estimated pressure, the amount in cubic centimetres less 10 being injected by the gravity method, unless the pressure is very high, when correspondingly less should be given. Intravenously 40 c.cm. may be injected for children up to 2 years, a child of 9 receiving 80 to 100 c.cm. White serum even slightly tinged with haemoglobin should not be used either intraspinal or intravenously; it may be given subcutaneously, but deeply coloured serum should be discarded.

318. Stoker's Cramp.

MADSEN (*Medicinsk Revue*, November, 1920) has observed as many as four cases of stoker's cramp within a few months. The patients were stokers from different ships, and they were admitted to hospital with symptoms of a remarkably uniform type. Common to all was a history of strenuous labour at a high temperature. Only one of the patients had actually lost consciousness. In other respects the clinical history was identical—headache, nausea, vomiting, thirst, lassitude, and painful cramp of various muscle groups. The blood pressure was low, but there were no signs of nervous disorders, and complete recovery was effected after a few days' rest in hospital. Though the author could find little information about this subject in medical books he learned that it was quite familiar to sailors, who associate it with stoking in the tropics, and who regard emaciation, inability to sweat profusely, the drinking of much water, and a weakness for alcohol as predisposing factors. The author regards this condition as an up-set of the heat regulation, but in correlating it with heat-stroke he notes that the latter is commonly associated with loss of consciousness, which is seldom seen in stoker's cramp. Possibly the excessive drain of fluids from the body may play a part, the cramp being caused by the same process of desiccation as that with which the cramps of cholera and diabetes are associated.

319. Rat-bite Fever.

PALMIÉN (*Finska Lakaresällskapet's Handlingar*, November-December, 1920) correlates the isolated outbreaks of rat-bite fever in countries where it has hitherto been unknown with the diversion of traffic caused by the war. But, as his table showing the distribution of the disease in various European countries indicates, it was detected in France, Spain, Germany, England, Italy, and Ireland before 1914. The author traces the entry of the disease into Finland to Japanese ships, which, in the autumn of 1920, brought sugar from Java to Helsingfors. Soon afterwards a railway porter was bitten by a rat; the wound became septic and gangrenous, and there were intermittent bouts of hyperpyrexia, each of these three bouts being accompanied by a universal eruption of large cyanosed spots. An intravenous injection of 0.5 gram of neo-salvarsan was given when the temperature was falling after the third bout of fever, and the subsequent course of the case was afebrile and uneventful. A mixture of staphylococci, streptococci, and rods of unequal length was found in the primary lesion, but the microscopic examination of the blood was negative. The author suggests that the progressive onsting of the *Mus rattus* by the large Asiatic *Mus decumanus* in Europe may be a factor of importance in the development of rat-bite fever in man. Only two decades ago the European *Mus rattus* flourished in Helsingfors, where it is at present never seen.

320.

Corebellar Agenesis.

MOERSCH (*Amer. Journ. of Nervous and Mental Disease*, December, 1920) reports two cases of cerebellar agenesis, the disease process in the first being confined entirely to the cerebellum with hesitancy in gait as the only clinical symptom, the actual cerebellar changes in the second case being less extensive but producing greater changes in associated areas, the right olive being atrophied, and symptomatically characterized by a moderate slowness of movements, together with some mental retardation. The cerebellum apparently acts as a relay to the cortico-petal system, and, when removed, a re-establishment of new impulses is required, having their origin in the cerebrum. Consequently agenic conditions are usually well compensated, while lesions occurring in adults rarely show such re-establishment of function. The cerebellum has no initiative function in itself, being subordinate to the cerebrum, and having a complex and combined function made up of component parts arising in various portions of the forebrain. The condition may supervene without being clinically demonstrable, and it is sometimes impossible to determine whether one is dealing with a congenital or an acquired lesion.

321.

Syphilitic Contagion of the Newborn.

LOMHOLT (*Ann. de Derm. et de Syph.*, No. 1, 1921) cites from literature two cases of children being infected by the mother at the time of birth, and records three cases of his own. In all these cases the mothers were infected late in pregnancy, and at the confinement had open infective sores on the pudenda. The chancres in four of the infants were on the scalp, and in the other on the cheek. In all the cases the chancres were multiple—in one case as many as eleven sores were found. To differentiate such cases from hereditary syphilis it is necessary to find the spirochaete in the scrape from the sore on the babe, and that the Wassermann reaction of the babe be negative or weakly positive. Further, the classical symptoms of hereditary syphilis are not present. A history of a recent infection in the mother is obtained—as a rule undetected until the confinement, or even shortly afterwards, when the eruption appears.

322.

Observations on Mongolism.

COZZOLINO (*La Pediatria*, January 15th, 1921) gives the following details of 23 cases of mongolian idiocy which he has observed between 1906 and May, 1920; 18 were males and 5 females. The youngest was aged 4 months and the oldest 10 years. All the children with three exceptions were under 2 years and sixteen were under 1 year. Only one showed the presence of mongolian spots, so that Cozzolino does not agree with Pentagna, who regards them as characteristic of mongolian idiocy. The familial occurrence of mongolism was exemplified by one family in which there were two cases. In one case there was congenital heart disease, probably patent interventricular septum, in another slight hypothyroidism, in two micro-melia, confined in one case to the upper limbs and in the other involving all four limbs. The blood pressure, examined with Pachon's instrument in 8 cases, was a little below normal. Dystrophic lesions of the fundus in the form of loss of choroidal pigmentation was found in 15 out of 17 cases examined.

323. Herpes Zoster as the only Sign of Latent Disease.

ARNSTEIN (*Wien. klin. Woch.*, January 13th, 1921) remarks that herpes zoster may be the only obvious sign of otherwise latent disease in the internal organs. He recommends, therefore, that in every case of herpes zoster a careful examination of the thoracic and abdominal organs should be made, as not infrequently in such cases disease of the internal organs may be discovered. He records 8 cases in which herpes zoster was the first indication of disease of the liver or lungs.

324.

Solid Food for Infants.

LOWENBURG (*New York Med. Journ.*, December 19th, 1920, and *La Pediatria*, November, 1920) gives his experience with 128 children from 6 to 12 months old when given solid food in addition to milk. He found it useful in most cases. None of the children except those suffering from severe diarrhoea received solid food exclusively, but they were usually given human or cow's milk in addition. Diarrhoea was treated successfully by the substitution of solid food for milk. Constipation was invariably escaped when green vegetables were given. No child under one year was given meat or fish. The solids chosen were chiefly cereals, potatoes, beans, spinach, carrots, beet, lettuce, and prunes.

408 B

SURGERY.

325.

Dakin's Solution in Surgery.

DE FINE LICHT (*Ugeskrift for Laeger*, January 27th, 1921) has not found Dakin's solution of much value when used as an ordinary antiseptic, whether it was used internally or on compresses. But he was more impressed with its action when it was injected into cavities after puncture and evacuation of the original products of inflammation. Particularly in more or less chronic cases of serous or purulent secretion in closed spaces, when the exciting cause was tuberculosis or gonorrhoea, was aspiration, followed by repeated injections and withdrawals of Dakin's solution, beneficial. The author gives a list of the 100 cases which he has treated in this manner. The results were unsatisfactory in cases of empyema, pyarthrosis of the knee, and articular rheumatism. In practically all the other cases, including 31 of tuberculous abscess, the desired effects were obtained. Discussing technical details, the author notes that injection of the solution at a short interval as every other day seemed to do more harm than good, and the interval he found most satisfactory was one of about eight days. As a rule, one to three injections were sufficient, and when abscesses were large, he found it convenient to puncture at two places so as to provide adequate irrigation of the diseased surfaces.

326.

Transplantation of Sex Glands.

LYDSTON (*Arch. méd. Belg.*, November, 1920), after claiming priority over Steinach and Voronoff, states that at the present time three distinct elements must be considered in the action of the transplanted gland: (1) The initial dose of the sexual hormone contained in the gland at the time of implantation; (2) the production of the nervous hormone by the interstitial cells of Leydig—the production continues as long as the smallest part of the glandular tissue persists; (3) the process of digestion of the different proteins by the tissue of the organism in which the graft has been made leads to the production of an enzyme which has a remarkably stimulating effect on all the cells of the body. According to Lydston grafts may be obtained from bodies in which death was due to any of the following causes: traumatism, acute poisoning, drowning, asphyxia by gas, or execution by hanging. No glands should be used for transplantation when death has not been instantaneous. A survival of even a few hours is sufficient to render a gland useless. A gland should never be employed for transplantation when the subject from whom it is taken has had even the slightest rise of temperature.

327. The Effect of Injections of Sugar on Anaesthesia.

EXNER (*Wien. klin. Woch.*, January 27th, 1921) tested the effect of intravenous injection of 40 c.cm. of 25 per cent solution of sugar on anaesthesia in 10 cases, the injection being given about ten hours before the operation. He was induced to undertake this experiment by having observed for several years that diabetics were very readily anaesthetized. Another motive was the well-known fact that women advanced in pregnancy or in labour are generally very easy to anaesthetize, require little anaesthetic, and hardly suffer at all from unpleasant after effects. Exner's 10 cases consisted of 3 laparotomies, 4 operations on the trunk, 2 on the extremities, and one on the brain. Six of the cases were anaesthetized without passing through any stage of excitement and only slight evidence of excitement was observed in the remaining 4 of whom 2 were heavy drinkers, one an epileptic, and one a very nervous individual. The patients came round remarkably quickly and usually without any of the usual retching and vomiting. Exner has not yet had sufficient experience to say definitely how much less anaesthetic a patient requires who has been injected with a solution of sugar, but he is under the impression that much less ether than usual is needed. If this supposition is confirmed intravenous injection of sugar will be of considerable importance in anaesthesia. No interference with the healing of the wound attributable to the injection of sugar was observed.

328.

Brain Abscess following Wounds.

LEFORT (*Thèse de Paris*, 1920) deals with abscess of the brain following wounds. He states that abscess occurs in 3.11 per cent of cranial injuries generally, in 24 per cent of infected wounds of the head. Only the superficial abscesses are easily diagnosed; deep abscesses may remain latent for several months and end by opening into the lateral ventricle. Foreign bodies are the usual exciting cause, often giving a positive culture after months of sojourn in the brain. The chief symptoms of the development of a

abscess are: headache, vomiting, slowing of the pulse, epileptiform crises. The bacteriology of the pus found is important in prognosis, staphylococcus being favourable, streptococcus much more serious. Lefort believes in the importance of auto-vaccination, which appears to have reduced the mortality in Villandre's clinic from 50 to 25 per cent.

329. Artificial Pneumothorax in Fractured Ribs.

SORESI (*Journ. Amer. Med. Assoc.*, February 5th, 1921) suggests the use of artificial pneumothorax in the treatment of fractured ribs. If there is no injury of the lungs or of the pleura, the best manner to prevent expansion of the chest would be by resorting to artificial pneumothorax, which obviously puts the affected thorax at complete rest. In one case in which the sixth, seventh, and eighth ribs were broken, and strapping had not relieved pain, immediately after artificial pneumothorax was effected the patient felt quite comfortable and remained so. Injections of nitrogen were repeated three times.

330. Central Rupture of Liver.

BAUER (*Vierteiljahrsschr. f. gerichtl. Med. öffentl. Sanitätswesen*, Bd. 56, Heft 1; *Zentralbl. f. Chir.*, January, 1921) has observed 12 cases of central rupture of the liver, with special reference to the formation of liver abscess. Central rupture is usually the result of compression of the viscus, a more direct blow tending to produce a fissure. Into the traumatized area blood and bile are poured, and may eventually be absorbed, or may, Bauer thinks, subsequently become infected. The common result of a liver tear—outpouring of blood and bile into the peritoneal cavity—does not, of course, occur unless the central injury be accompanied by fissuration elsewhere. The right lobe is more commonly injured than the left. In one case a man fell into a hole and fractured his right fifth rib. For months he complained of local pain and pain on breathing, and held himself so bent that he was ordered a corset. A year later he was suddenly taken ill with rigors and high fever, and was treated for grippé. He died two weeks later, and at necropsy a liver abscess was found. Bauer believes that a traumatic etiology of liver abscess has been much neglected in the past. He thinks the abscess may follow between eleven days and one year after the injury, in rare cases four and ten years later.

331. A Fatal Case of Tonsillar Abscess.

COULET (*Rev. de lar., d'otol., et de rhinol.*, January 31st, 1921) remarks that suppuration in the tonsil or peritonsillar tissue is a frequent event, which occurs in subjects whose tonsils are chronically infected as the result of an increase in the virulence of the organisms or a temporary decline in systemic defences. The condition, however, is generally regarded as unpleasant rather than dangerous. The only fatal complication mentioned in the textbooks is ulceration of the internal carotid or oedema of the glottis. Coulet records a case of tonsillar abscess, probably of influenzal origin, which in four days caused the death of a previously healthy and vigorous young man aged 20 as the result of mediastinal infection. The autopsy showed a large abscess in the right tonsil, cellulitis of the neck, and sero-purulent pleurisy, with marked degeneration of the pericardial sac.

332. Angeliomata of the Larynx.

IRWIN MOORE (*Journ. of Laryng. and Otol.*, January and February, 1921) reviews all recorded angeliomata of the larynx, with special reference to haemorrhage and treatment. In the unoperated cases haemorrhage varied from a small to a severe amount, from single to frequently repeated bleedings. In operated cases severe bleeding occurred in most, but in the cases of thyro-fissure and those treated by radium there was no bleeding; no death was recorded from spontaneous haemorrhage. Of non-operative treatment sulpho-ricinate of phenol and radium proved successful in some cases. If the tumour is not causing serious trouble it is best left alone, but any nasal obstruction or catarrh should be remedied, because of its presence possibly encouraging growth. Of operative measures endolaryngeal removal exposes the patient to the risk of haemorrhage difficult to control, laryngeal spasm, and the entrance of blood into the bronchi. Thyro-fissure is safer, bleeding being practically nil, and recent improvements in technique avoid the risk of opening the larynx. By this means a wide and thorough excision can be carried out, the cut surface of the mucous membrane being afterwards reunited so as to restore its continuity. It is important to differentiate angelioma cavernosum from lympho-angioma, since the latter can more safely be dealt with endolaryngeally without recourse to thyro-fissure.

OBSTETRICS AND GYNAECOLOGY.

333. The Management of Breech Presentation.

PFEIFFER (*New York Med. Journ.*, January 29th, 1921) points out that, unless contraindicated by the etiology, breech presentations may be corrected before or early in labour oftener than is commonly supposed if the membranes are unruptured. Under anaesthesia if necessary, with the patient in slight Trendelenburg position, external version should be attempted. After labour has begun and the membranes have ruptured interference is dangerous, unless positive indications arise in the mother or child, since a simple case in which spontaneous delivery might probably occur may be converted thereby into a difficult one endangering the life of the child. When the buttocks reach the floor of the pelvis the soft parts should be widely dilated, either manually or by central episiotomy, in order to minimize the possibility of a considerable tear if the extended arms or after-coming head have to be hastened. Traction is dangerous, and if the efforts of the patient do not advance the breech, compression should be made on the fundus by an assistant. Forceps to the breech are dangerous, and though seldom necessary for the after-coming head, they should be in readiness, as also should be all other necessities for possible emergencies. Caesarean section may occasionally be needed on account of associated anomalies rather than because of the presentation alone.

334. Radium Therapy in Carcinoma of the Uterus

BETRIN (*U a Gyn.*, July-August, 1920) describes the technique of radium therapy for carcinoma of the uterus. The first application of radium for carcinoma of the uterus at the Gynaecological Clinic in Geneva was in 1914, and at that period a very small dose, 50 to 60 mg., was employed for a very short time, and repeated at long intervals. The filtration used was 2 mm. of lead and an envelope of rubber, the whole being placed in the vagina in direct contact with the tumour. At the beginning of 1915 Dr. Chapuis introduced the method of "cross fire" inside and outside the cervix, the dose being raised to 150 mg. From this was gradually evolved the present technique, which the author deals with under three headings: (1) choice of apparatus, (2) preparation of patient, (3) dangers of treatment, and lesions caused by errors of technique. In nearly every case the application was intraterine and vaginal combined. For the uterus a long curved tube was used, for the vagina the shape of the container varied for each individual case. The total amount of radium was never more than 110 mg.; the duration of the first application was from twenty-four to forty-eight hours, and the subsequent ones twelve to eighteen hours. The apparatus was sterilized by soaking in absolute alcohol. The filtration (which is of very great importance—to stop the alpha and soft beta rays which cause necrosis) used was 1 mm. to 1.5 mm. of lead or brass, inside an envelope of rubber. For the vulva a combined filter of brass and lead is used. Preparation of the patient consists in rendering the vagina and cervix as aseptic as possible. The question of curettage of the growth is still one of controversy, but the author considers that it should not be done. Dangers and lesions due to faults in technique must be noted. The danger of sepsis is a very real one, especially at the first application, but can be eliminated to a great extent by careful preparation of the vagina. The rectum is very sensitive to radium rays, and unless adequate protection is given, pain, tenesmus, diarrhoea, mucous discharge, or even ulceration, may result.

335. Treatment of Uterine Fibroids.

VINEBERG (*New York Med. Record*, January 15th, 1921) advocates myomectomy rather than radium and x rays in the treatment of uterine fibroids in women under 40 years of age, on the ground that the menstrual function is preserved. He quite rightly points out that hysterectomy with conservation of the ovaries is a poor substitute for the normal menstrual function; and the action of x rays and radium definitely produces an artificial menopause. The statistics of W. J. Mayo show 617 abdominal myomectomies with a mortality of 15 per cent., and only 2.5 per cent. required a second operation many years later. In the author's 120 cases there was no mortality, and nine of the patients had subsequent pregnancies. In all cases the author advises opening the cavity of the uterus to exclude the possibility of a submucous fibroid or polypus, and in order to enette the endometrium.

PATHOLOGY.

336. Blood Platelet Enumeration

GRAM (*Acta Med. Scandinavica*, November 10th, 1920) gives a simple method for the enumeration of the blood platelets, which cannot be detailed here, owing to the fact that the calculations necessitate the use of a table of constants. The particular paper is written in English and may be consulted with advantage by those interested in haematological technique. Gram found from the examination of 122 patients with indifferent diseases that the blood platelets varied between 200,000 and 500,000 per cubic millimetre, the majority being between 300,000 and 450,000. In 27 absolutely healthy men and women the counts varied between 300,000 and 550,000, the majority ranging from 350,000 to 450,000. The number of platelets was found to be diminished in cases of severe pernicious anaemia and leukaemia, and in these patients the symptoms of a haemorrhagic diathesis appeared sometimes when the number of platelets was between 100,000 and 200,000, while a fall below 100,000 generally was accompanied by haemorrhagic symptoms. Several authors have reported low platelet counts in typhoid fever, the lowest counts being obtained in cases showing intestinal haemorrhages. In chronic tuberculosis the development of purpura often occurs simultaneously with a pronounced reduction in the platelet count. Gram reports the condition in 14 cases of uncomplicated influenza and 12 cases of influenzal pneumonia. In the former group the counts showed that at the beginning there was a more or less pronounced fall in the number, which only rarely was strong enough to cause a haemorrhagic diathesis; in the second week of the disease, however, the count rose again and sometimes reached abnormally high values. In the latter group the count fell very low at the commencement and remained low for a week or more, afterwards considerably increasing. The platelet deficit was frequently accompanied by haemorrhagic symptoms, generally epistaxis. There was no parallelism between the variations in white cells and platelets.

337. Colloidal Gold Reaction in General Paralysis.

HAGUENAU (*C. R. Soc. Biologie*, November 6th, 1920) adds his testimony to the value of Lange's colloidal gold reaction in diseases of the central nervous system. Thus, in testing the cerebro-spinal fluid in 30 cases of general paralysis he obtained a typical "paralytic curve" in 28 instances. In the other two cases only a partial flocculation of the gold was obtained, and they might be classed as atypical irregular types. In 6 cases of tabes a typical "tabetic curve" was obtained in 5, but in the remaining case—a tabetic without mental symptoms but with a positive Wassermann reaction—the curve obtained approached more to the "paralytic" type. In 5 cases of syphilitic myelitis or syphilitic hemiplegia showing a positive Wassermann reaction the "paralytic" type of curve was not obtained, nor were reactions of this type encountered in other pathological cerebro-spinal fluids. The author concludes that in the reaction of Lange we have a very valuable means of discriminating between general paralysis and other syphilitic affections of the central nervous system. At a previous séance of the society (October 30th, 1920) the author—who, like most observers, had found difficulty in always preparing stable and useful solutions of gold—reported a method whereby these unaccountable variations of solution could be avoided.

338. Dissemination of *Spirochaeta pallida* in Experimental Syphilis.

EBERSON (*Arch. of Derm. and Syph.*, February, 1921) states that spirochaetes have been isolated from the blood stream of experimentally infected rabbits seven, ten, and thirty days after intratesticular inoculation, at times corresponding to twenty-six, twenty-three, and three days prior to the appearance of any initial lesion. The regional lymphatic glands have been found by Brown and Pearce to contain spirochaetes as early as forty-eight hours after infection, and early invasion of the blood stream was demonstrated by experimental infection with blood obtained from rabbits one week after scrotal inoculation. Thus he establishes the fact that syphilitic infection is not to be regarded as limited to the portal of entry. He deduces from the early finding of spirochaetes in the lymphatic glands that the intermediary stage of the spirochaete does not exist. The spirochaetes can be found in the regional glands before they can be found at the seat of inoculation, but the failure to find them at the seat of entry does not in any way prove a life-cycle for the spirochaete.

339.

Renal Glycosuria.

STROUSE (*Arch. Int. Med.*, December 15th, 1920) considers that the diagnosis of renal glycosuria necessitates four things: (1) glycosuria without hyperglycaemia, (2) glucose excretion almost entirely independent of carbohydrate intake, (3) absence of diabetic symptoms, and (4) no subsequent development of diabetes mellitus. Few cases indeed have been reported in which observation has been sufficiently prolonged to rule out the last two points. Strouse records four cases of renal glycosuria which have been under his observation for from two to eight years; on two of these metabolic studies were conducted. In all, the glycosuria has been persistent, and none has shown symptoms of diabetes mellitus. In one, tests for renal function seven years after onset showed no depression of renal function except in regard to phtalein excretion. The two who have been longest under observation show at the end of four and eight years respectively a utilization of glucose that cannot be considered strictly normal, one at the end of seven years exhibiting a distinctly pathological alimentary hyperglycaemia. This may possibly indicate the beginning of metabolic disturbance.

340.

Extraction of Leucocytic Ferments.

TURRO (*C. R. Soc. Biologie*, January 15th, 1921) has obtained strong ferments from leucocytes in the following manner: A fixation abscess was produced in the abdomen of dogs, and the pus cells, having been withdrawn at the most acute period of the process, were washed three times. They were then dehydrated with acetone, filtered off, dried *in vacuo*, and afterwards pulverized. To 20 c.cm. of sterilized 1 per cent. saline solution, 1 gram of this powder was added and the mixture shaken for fifteen minutes; then 30 to 40 drops of chloroform were added, and the tube, after being corked, was again shaken for fifteen minutes, and put in the incubator at 40° C. Tested from hour to hour the ferment activity of the fluid was found to reach its optimum in twelve hours. After that time the fluid was centrifuged and the extract obtained by decanting was clear and limpid. Turro found that 1 c.cm. of this extract produced complete hydrolysis of 1 c.cm. of 1 per cent. glycogen in twenty-four hours. Its bacteriolytic action was tested on anthrax bacilli. The growth from two agar slopes (approximately 244 mg. of fresh culture) was emulsified in 1 c.cm. of saline, and an equal quantity of the extract was added. At the end of eight hours in the incubator at 40° C. the organisms appeared as a fused amorphous precipitate which was soluble in weak solutions of soda. The author states that the leucolysis obtained from pleural and peritoneal exudates are more active still. The activity of these ferments, thus prepared, decreases rapidly in spite of all precautions, and in three to five days it is quite lost.

341. Causes of Paralysis of the Recurrent Laryngeal Nerve.

SCHMIDT (*Hospitalstidende*, January 12th, 1921) has analysed the causes of paralysis of the recurrent laryngeal nerve in 100 cases observed in two Danish hospitals. Up to the age of 3 years there were only bulbar paralyses, post-infectious and traumatic. From 35 to 60 there was a steady rise in the frequency of this paralysis, followed after 60 by an equally steady fall. There were 24 cases of cancer of the oesophagus, among which there were only three women. Diseases of the lungs and mediastinum accounted for 14 cases, equally distributed between the two sexes, and aneurysm of the aorta accounted for 13 (9 males). In several of these cases hoarseness developed before any other symptom indicative of disease. There were 8 cases of heart disease (all women), and, curiously enough, in two of these cases the paralysis was right-sided. Of the remaining 6 left-sided cases 3 were associated with mitral stenosis. All the 9 cases of tumour of the neck were right-sided. This finding the author explains by a reference to the course of the recurrent nerve in the neck being more superficial and exposed on the right than on the left side. When the paralysis was associated with goitre (9 cases) it was anticipated that the disease would in most cases prove to be malignant; but in reality this was the case only in 3 of the 9. The group of 6 post-infectious cases was very mixed, including as it did typhoid fever, influenza, diphtheria, and rheumatism. Among the bulbar and pseudo-bulbar cases (7) were 3 with syringomyelia. The rest of the 100 cases were made up by a few obscure cases and pathological curiosities. In about 60 cases the cause of the paralysis was situated below the upper aperture of the thorax, in 45 the cause was carcinoma or sarcoma, and in about 70 the disease was fatal.

EPITOME OF CURRENT MEDICAL LITERATURE.

MEDICINE.

332. The Influence of Athletics on the Heart

DIEDERIKSEN (*Acta Medica Scandinavica*, January 14th, 1921) gives the results of systematic examinations of the heart of athletes before and after the 50 kilometre ski race at Holmenkollen. Since 1885 these competitors have been medically examined, and since 1914 this examination has been conducted on searching lines: weight and height, position of apex beat, cardiac dullness, heart sounds, pulse, blood pressure, and urine, as well as vital capacity, being investigated with a view to noting changes effected by the prolonged strain of the race. Of 226 competitors, 8 showed an outward displacement of the apex beat after the race, and in 2 the cardiac dullness had extended inwards. In 30 there was a distinct inward displacement of the apex beat after the race, and in some whose apex beat was not distinct before the race it showed distinctly after it, but was always within the nipple line. None of the 8 men with outward displacement of the apex beat after the race showed any sign of cardiac failure, and the condition was almost certainly not due to dilatation. Nor could a history suggestive of dilatation be obtained in those who fell out during the race. The urine of most contained albumin after the race; blood cells, prothrin, and granular and hyaline casts were also common finds, but there was only one case of definite haematuria. After giving details of many other lines of investigation, including the after-histories of these athletes, the author comes to the conclusion that long-distance ski racing, as conducted in Norway, has no immediate or remote ill effect on the heart.

333. An Epidemic of Barlow's Disease.

GIORGI (*La Pediatria*, January 15th, 1921) describes an outbreak of Barlow's disease which occurred in Venice at the end of 1919 and first half of 1920. All the cases showed the classical triad of symptoms—namely, anaemia, characteristic changes in the bones, and scorbutic gingivitis, except two in whom the gingival lesions were absent. In almost all the children the typical symptoms of Barlow's disease were associated with rickets. In one case rickets was combined with the spasmodic diathesis. In all the cases dietetic treatment, which is the most valid proof of the diagnosis of Barlow's disease, was successful. This disease is rare in Italy, not only because up to a few years ago artificial feeding was rare in that country, but because patent foods were not so popular as at present. All the children in the epidemic described by Giorgi belonged to the working classes, and had been fed for a prolonged period on a special form of condensed milk which had entirely taken the place of fresh milk in Venice.

334. An Outbreak of Tinea Tonsurans due to *Microsporon lanosum*.

CORNAZ (*Rivista di Scienze e Lettere*, November, 1920) reports an epidemic which occurred in a children's home at Leansane of twelve cases of tinea tonsurans due to the *Microsporon lanosum*, a ringworm of animal origin. A remarkable feature of the outbreak was the low degree of infectivity of the fungus. Had the *Microsporon lanosum*, the most frequent causal agent of ringworm, been responsible, many more children would have been infected. A ringworm of animal origin cannot be distinguished from *Microsporon audouinii* either by clinical or microscopical examination. The fungi can only be differentiated by cultures. As is the rule with the *lanosum* variety of ringworm, several of Cornaz's patients showed concurrent lesions of the skin. Sometimes there was slight reaction round the lesions on the scalp; this is not seen in ordinary ringworm. The patches were also slightly raised. All the cases were successfully treated by x-rays.

335. Intravenous Injection of Tartar Emetic.

BENJAMINS (*Nederl. Tijdschr. v. Geneesk.*, January 1st, 1921) states that good results have been obtained by this method in nine diseases—namely, trypanosomiasis, leishmaniasis, granuloma venereum, bilharziasis, dracontiasis, filariasis, blastomycosis, distomiasis, and chronic malaria. He considers that the treatment deserves a trial in other diseases, especially helminthiasis, diseases allied to blastomycosis—such as actinomycosis—or to trypanosomiasis and leishmaniasis, such as piroplasmiasis. Most writers recom-

mend a sterile 1 per cent. solution. Sterilization can be carried out by a Berkefeld or Chamberland filter. According to De Laugen stronger solutions, up to 5 per cent., can be employed, the advantage of which is that a smaller quantity can be injected. The injections are given every other day. The first day 2 c.c.m. are given, containing 25 mg. of the salt, two days later 4 c.c.m., then 5 c.c.m., and finally 10 c.c.m. After an interval of two months a second series is given. A third series is seldom required. Benjamins maintains that this method of treatment, which plays a considerable part in tropical medicine, deserves a wider popularity.

336. Lethargic Encephalitis in the Bordeaux Region.

ROBERT (*Ann. Path. et Clin. Med.*, *France*, January 16th, 1921), as the result of an inquiry into the prevalence of lethargic encephalitis in the Bordeaux region, has collected 145 cases which occurred between March, 1918, and October, 1920. Their classification was as follows: Meningo-encephalitic form, 56 cases; pontine and bulbo-pontine forms, 32 cases; choreic and myoclonic forms, 15 cases; mental forms, 14 cases; epileptic form, 2 cases; hemiplegic form, 2 cases; cerebellar form, 1 case; spinal form, 6 cases; polynuclear form, 5 cases; unclassified, 14 cases. Of the 145 cases 27 died—a mortality of 18.6 per cent., which was considerably below the figures of 35 and 50 per cent. reported previously. But although recovery was frequent it was far from being always complete; convalescence was extremely slow and sequelae persisted for a considerable time. Mentally the patients remained depressed and incapable of sustained intellectual effort for a long period, and many had to be sent to asylums. A generalized spastic condition of the type of paralysis agitans was very frequent. The prognosis of the myoclonic form was usually grave: of 12 cases, 7 died and 4 were in a desperate condition. No cases of contagion were observed. There was nothing found to justify the conclusion that there was any relationship between lethargic encephalitis and influenza or between lethargic encephalitis and acute poliomyelitis. Lethargic encephalitis was observed in both sexes, in childhood and adult life. Cases were rare after 40.

337. Methyl Alcohol Poisoning.

HASSELL, HULLMAN, and GARDNER (*Ann. Int. Med.*, January 15th, 1921) discuss the significance of the acidosis of methyl alcohol poisoning, and the favourable results of treatment with sodium bicarbonate. In experimental animals the severity of the intoxication was at times entirely at variance with the degree of acidosis, and it was found that the intravenous administration of an alkali was dangerous, especially if done rapidly; and even when administered slowly, vomiting, purging, and convulsions occurred in some of the dogs. While in methyl alcohol poisoning there is a reduction of the reserve alkali of the blood, this is not always commensurate with the severity of the symptoms. Although the rapid method of administration to the dogs is not likely to be adopted on human beings, the results serve as a warning against the too ready use of intravenous injections of hypertonic solutions of sodium bicarbonate. Alkaline therapy in methyl alcohol poisoning is not encouraging, and a similar want of success has followed the employment of sodium bicarbonate in the treatment of delayed chloroform poisoning.

338. Hyperthermia as a Symptom of Demorphinization.

BOLTON (*Nederl. Tijdschr. v. Geneesk.*, November 20th, 1920) records the case of a man, aged 26, whose doctor prescribed injections of 10 mg. of morphine and ½ mg. of adrenalin daily for asthma, from which the patient had suffered from early childhood. He gradually increased the dose of morphine until after three months he was taking 100 mg. a day; he was then ordered to discontinue its use. Troublesome cramps in the calves developed, but colic and diarrhoea were only slight, and symptoms of collapse were not observed. On the other hand, the temperature rose several times a day to 104 and sometimes to 105.8. In spite of the high temperature he did not appear to be ill, and the pulse was only 60. The possibility of pyogenic or malarial infection was excluded by examination of the blood, which was always negative. Bolton attributes the hyperthermia to the fact that

morphine exercised an inhibitory influence on the heat-regulating centres, and that during demorphinization violent irritation of the heat-regulating and vasomotor centres occurred, so that production of heat considerably exceeded its loss.

349. Sodium Citrate Treatment of Thrombo-angiitis Obliterans.

ACCORDING to the technique that STEEL (*Journ. Amer. Med. Assoc.*, February 12th, 1921) followed, during the first month the patient is kept in bed with the legs constantly under a hot-air electric-light bath at 110° F., and 250 c.cm. of 2 per cent. sodium citrate solution is given intravenously every second day. During the second month the interval of injection is lengthened to every third or fourth day; daily leg massage is given, and the patient is put in a wheel chair with the feet hanging down for a short time each day; or, if the disease is not advanced, some walking is allowed. The intervals of injection are gradually lengthened until at the end of a year the patient receives one every two weeks. Increased walking is permitted as the symptoms subside and evidence of a functional collateral circulation appear. Potassium iodide, in ten-drop doses, three times daily, is given during the whole course of treatment. The iodide is always well borne. The length of treatment is regulated by the results obtained in establishing a functional collateral circulation. Six patients have been treated. Two have resumed their regular occupations. One was walking around again functionally able, but had no financial spur to set him to work. One who previously had had his leg amputated had resumed his occupation as a playwright. One patient was progressing satisfactorily. In the sixth case—a desperate one—the patient walked after one year of treatment, but suffered a relapse after four months of walking. He was now improving under a second course of injections.

350. The Diagnosis of Hydatid Disease.

LURIDIANA (*Il Policlinico*, Sez. Prat., January 10th, 1921), as the result of his investigation of ten cases, comes to the following conclusions: (1) The most trustworthy biological methods for the diagnosis of hydatid disease are deviation of the complement and the intradermo reaction, but neither of them is constantly positive. (2) The two methods may supplement each other; in Luridiana's cases where one was negative the other was positive. (3) The intradermo reaction may be negative (a) owing to interference with absorption of antigen due to causes inherent in the cyst wall, (b) owing to disappearance of antigen from suppuration of the cyst, (c) from excessive absorption of antigen due to antianaphylaxis.

351. Telangiectasis.

GOLDSTEIN (*Arch. Int. Med.*, January 15th, 1921) reviews the literature of hereditary haemorrhagic telangiectasis with recurring (familial) hereditary epistaxis, and reports eleven cases in one family. Telangiectasis is a dilatation of capillaries or venules, and the hereditary type occurs in three forms—pin-point, spider form, and nodular. The lesions are generally confined to the skin of the face and the mucous membranes of the mouth and nose, but they may also involve other parts of the body, and the tendency to recurring nasal haemorrhage (familial in type) is a prominent feature, together with a hereditary history of recurring haemorrhages and telangiectases in the family. The clotting and bleeding time is normal and there is no history of haemophilia in these cases. Fifteen-grain doses of calcium chloride, three times a day, appear to be of some use, though treatment does not afford much relief from the haemorrhages, and no general treatment is effective owing to the inherent congenital developmental defect of the vascular system. Local treatment may reduce the number and severity of the haemorrhages and improve the general condition, and since the bleeding tends to become worse after the fourth decade it is important to try to stop the attacks of epistaxis, especially in women reaching the climacteric. In the case recorded with severe recurring nasal haemorrhages two sisters, seven children, and the patient's mother, all suffered from the same disease. Males and females are equally affected and are equally capable of transmitting the disease to their offspring, and haemorrhage is the one constant symptom, and the source of the secondary anaemia and all other symptoms.

352. Haemoptysis and the Action of Camphor.

ZEHNER (*Zeit. f. Tuberk.*, August, 1920) finds that camphor used as 20 per cent. oil of camphor acts in a mechanical manner, its fermentative, serological, and other effects being secondary. He considers it indispensable in every form of haemoptysis.

SURGERY.

353. Ulcer of Jejunum following Gastro-enterostomy.

ULCER of the jejunum following gastro-enterostomy is stated by HORSLEY (*Journ. Amer. Med. Assoc.*, February 5th, 1921) to be caused by gastro-enterostomy. The manner in which it produces the ulcer has been the subject of considerable discussion. A jejunal ulcer is rarely found except after gastro-enterostomy, though sometimes it occurs after diseases that destroy the efficiency of the pyloric portion of the stomach or that interfere with the normal character of the gastric or duodenal secretion. Horsley reviews the literature, especially with reference to the etiology of the condition. He suggests that the probable explanation is that the changed physiology in the jejunum caused by the gastro-enterostomy weakens the resistance of its tissues, and that traumas or non-absorbable sutures that are easily taken care of elsewhere cannot be borne here. A jejunal ulcer often occurs around the margin of the gastro-enterostomy opening. This probably is because the mucosa of the jejunum nearest this opening is least protected from the effects of the gastric juice. Its resistance therefore is lower, and the trauma or the suturing, particularly if there are non-absorbable sutures, causes the ulcer. The ulceration may occur, however, where the current of gastric juice strikes the wall of the jejunum opposite the stoma. In such ulcers in a region where the blood supply of the jejunum is unimpaired in any way, Horsley says it seems that no other interpretation can be put on the cause of the ulcer than that it is due to the effect of the gastric juice. One such case was described in detail; the patient had a posterior gastro-enterostomy performed for duodenal ulcer, but a jejunal ulcer developed later, and altogether four operations were performed before the patient made a satisfactory recovery.

354. Treatment of Fractures.

ORR (*Journ. of Orthop. Surg.*, January, 1921), from military hospital experience during the war, concludes that the Thomas splint and plaster-of-Paris are the two most important agencies in the treatment of fractures of the femur and leg. The less the Thomas splint is modified, the more efficient it is. In fractures of the neck of the femur and of the leg below the knee, either open or closed, plaster-of-Paris is usually indicated, but for fractures of the shaft of the femur the Thomas traction splint is far more useful, both as an emergency and as a continuation splint, than all other devices recommended, and skeletal traction for fracture at the extreme lower end of the femur or leg is a justifiable addition. In extensive compound injuries of the thigh the Balkan frame, and in a few instances the Hodgen splint, may be serviceable. Moleskin plaster or adhesive glue must be used for traction, which is assisted by elevation of the foot of the bed with the splint anchored at the lower end. The more general adoption of the Thomas splint, and the elimination of most other methods, would tend towards rapid improvement in treatment and results in fracture of the thigh and leg. Complete immobilization of a fracture is rare, and stiffness, excess callus, adhesions, and ankylosis are mainly due to failure to adequately immobilize.

355. Traumatic Serous Meningitis in Childhood.

LINDBERG (*Hygiea*, January 16th, 1921) suggests that though little has been published with regard to traumatic serous meningitis in childhood, this condition is far from rare. Were lumbar puncture to be practised whenever a blow on the head is followed by signs of meningitis, serous meningitis with increased intraspinal pressure would often be found. He records two cases, the ages of the patients being 10 and 4 years respectively. In both a slight injury to the head, caused by a fall on the ground, was followed in a few days by alarming signs of meningitis. In both the pressure of the cerebro-spinal fluid was much raised, being as high as 300 mm. in the second case. The withdrawal of 15 and 20 c.cm. respectively of this fluid, the composition of which was normal, resulted in dramatically rapid improvement, and complete recovery was ultimately effected in both cases. The author advocates lumbar puncture in every case with signs of meningitis; however sure the physician may be that the condition is due to tuberculous or septic meningitis, he may be wrong. And even if a serous meningitis is due to the activities of the tubercle bacillus, it should not be regarded as incurable. The author has seen a case of serous tuberculous meningitis terminating in recovery, and he refers to four similar cases, observed in Göppert's hospital. It is still doubtful what the

fate of patients suffering from traumatic serous meningitis is in the absence of relief of pressure by lumbar puncture; but it is certain that this procedure is remarkably beneficial.

356. Transplantation of the Testes in Man.

LICHTENSTEIN (*Zentralbl. f. Chir.*, January 8th, 1921) has performed this operation in 18 cases, in 15 of which testes in the inguinal canal were transplanted, and in 3 cases normal testes. In one case the patient had lost his testes eight years previously, and yet sexual signs returned. One homosexual lost all his signs of homosexuality after transplantation, and 7 other cases showed considerable improvement. A favourable result was also observed in cases of eunuchoidism, consisting of 6 cases of loss of the sexual glands before puberty, 3 cases of acquired and 4 of congenital eunuchoidism.

357. Echinococcus Disease of the Lung and Pneumothorax Treatment.

ACCORDING to ALEXANDER (*Zentralbl. f. inn. Med.*, November 15th, 1920), who records an illustrative case, artificial pneumothorax is contraindicated in pulmonary echinococcus disease which is not definitely connected with a bronchus, owing to the danger of rupture of the cyst into the pleural cavity. On the other hand, if there is a definite connexion with a bronchus, pneumothorax treatment can be employed, but much increase of pressure should be avoided. Pneumothorax treatment is a good preparation for the radical operation, and should be continued after the operation, so as to promote a more rapid healing of the wound cavity.

358. The Use of Propyl Alcohol in Surgery.

PLETH (*Il Policlinico*, Sez. Prat., January 10th, 1921), who has used various colouring matters, such as malachite green, brilliant green, and fuchsin, in the treatment of wounds for several years, has recently been in the habit of suspending the colouring matter in a solution of 25 per cent. propyl alcohol. He has come to the conclusion, from observation of several hundred cases, that infected wounds, when treated with propyl alcohol or with colouring matter dissolved in propyl alcohol, are cured more rapidly than by the Carrel-Dakin method. He has used this treatment with success in skin diseases, such as blastomycosis and actinomycosis, and has obtained good results in disinfection of silk ligatures in 25 to 50 per cent. propyl alcohol with or without the addition of an aniline dye.

359. Ludwig's Angina in a Haemophilic Subject.

FELICIANGELI (*Il Policlinico*, Sez. Prat., January 3rd, 1921) records the case of a man who an hour after an operation for Ludwig's angina developed profuse and persistent haemorrhage from the wounds in the neck. Ergot, adrenalin, gelatine, peptone and diphtheria antitoxins proved ineffective, and it was not until the seventh day after the operation that some fresh horse serum was obtained, and 200 c.cm. were injected. A surprisingly good result was obtained, there being a marked decrease in the haemorrhage. During the next six days 120 to 200 c.cm. of the serum were injected daily, and recovery took place.

360. Meningococcal Arthritis.

MERLE (*Thèse de Paris*, 1920) discusses the different forms of arthritis which occur in the course of cerebro-spinal meningitis. Usually these take a purulent form, have a decided predilection for the knee, and are relatively indolent. Sometimes the joint affection precedes the meningitis and may be mistaken for rheumatism. In this case the onset of cerebral symptoms may lead the clinician to think of cerebral rheumatism. Diagnosis is of course easily made by exploratory puncture of the joint. Usually the arthritis will clear up under serum treatment of the usual type, but if the joint trouble persists, aspiration of the pus and intra-articular injection of antimeningococcus serum may be tried. Only in the most resistant cases should the joint be opened and drained, although this step does not always lead to ankylosis.

361. Traumatic Optic Atrophy.

GINESTOUS and DEBÉDAT (*Journ. de Méd. de Bordeaux*, November, 1920) report a case of monocular blindness following trauma. A boy hit his right frontal region violently against a tree. He immediately lost consciousness and had epistaxis. Radiography revealed no fracture of the skull. Vision in the right eye was completely abolished, the disc becoming white and atrophic. The authors surmise a perineural haemorrhage leading to atrophy of the optic nerve.

OBSTETRICS AND GYNAECOLOGY.

362. Treatment of Placenta Praevia.

THELIN discusses (*Rev. med. de la Suisse rom.*, February, 1921) at length the value of the following methods of treatment of placenta praevia: (1) Accouchement forcé, (2) rupture of the membranes, (3) plugging of the vagina, (4) bipolar version and tension on the leg of the child, (5) pressure by means of a hydrostatic bag, such as Champetier de Ribes's, and (6) Caesarean section. Accouchement forcé, he states, has been abandoned because of the risk of severe lacerations of the cervix. Rupture of the membranes, he considers, is only useful in those cases where there is a partial placenta praevia. Plugging of the vagina is useful in cases where labour has only just commenced, and the cervix is not dilated. The method of Braxton Hicks—that is, bipolar version—has become a classic because of its great success, and has reduced the maternal mortality considerably. It has, however, one great disadvantage—namely, the large foetal mortality. All the methods so far mentioned require no very great experience or skill on the part of the operator, but they are all attended by a very high foetal mortality. The one method by which this high mortality can be overcome is Caesarean section, and he compares the results obtained by some obstetricians—namely, 100 per cent. of mothers and children living—with the results by other methods, which average a foetal mortality of 53 per cent. and a maternal mortality of 9.3 per cent. He points out a number of contraindications to Caesarean section, the most important of which is the suspicion of sepsis in the vagina or cervix. The diagnosis of a dead child also should contraindicate this method. In conclusion the author gives in detail six cases of placenta praevia which he himself treated by Caesarean section; in every case the mother survived, and likewise the child, with one exception where the child was dead at the commencement of the operation.

363. Is it Necessary to Treat the Pregnant Wife of a Syphilitic?

CARLE (*Ann. de Derm. et Syph.*, No. 1, 1921) discusses this subject and definitely concludes that the wife of a syphilitic is only to be treated if she shows signs, clinically or by blood test, of the disease. Conceptional syphilis, he says, does not exist, and if the *enceinte* woman develops syphilis it is not contracted through the child or placenta. The old habit of giving mercury and iodide to the pregnant wife of a syphilitic husband is bad and even harmful. Should the *enceinte* woman have clinical or laboratory evidence of syphilis, then she must be treated by the modern intensive method. Carle holds that the *enceinte* woman should not be told of the taint in her husband as she is liable to develop neurasthenia or syphilophobia. It may be, and often is, necessary to obtain the help of the family physician to carry out the complete examination and to obtain the blood for the blood test.

364. Coloured Colostrum.

REICHENFELD (*Wien. klin. Woch.*, January 6th, 1921) states that, while discoloration of the mammary secretion by blood, haemoglobin, or its derivatives is by no means uncommon, very few cases have been described of non-haemogenous discoloration of the colostrum. He records a case of a woman, aged 34, suffering from endometritis and inflammation of the adnexa, probably due to abortion, who presented a thick, first dark green and then light green, secretion from the nipples, especially the left. She stated that she had suckled her child, who had been born two years previously, when the milk had a normal appearance. Microscopical examination of the secretion showed relatively few colostrum corpuscles, and mainly fat droplets. Bacteriological examination was negative. Inoculation of normal colostrum and cow's milk with the green secretion did not produce any change in these fluids. The green secretion lasted for the three months that the patient was kept under observation, and was always more plentiful from the left than from the right breast. The urine, sweat, and saliva showed no abnormal coloration. The Wassermann reaction was negative, and there was no evidence of syphilis.

365. Primary Carcinoma of the Vagina.

KLEEMANN (*Monats. für Geburtsh. u. Gynäk.*, li. 4) records a case of this rare condition, accidentally discovered in a woman, aged 75, who suffered from prostatica. Total extirpation was performed. The tumour was a squamous-celled carcinoma and the cervix was normal.

PATHOLOGY.

366. Morbid Anatomy of Lethargic Encephalitis.

ANGLADE (*Gaz. hebdom. des Sci. Méd. de Bordeaux*, January 16th, 1921) states that all the cases examined by him presented the following characteristics: (1) The cerebral cortex in the frontal region was always the site of a process of encephalitis. The large and moderate sized nerve cells presented various degrees of chromatolysis. (2) The grey substance of the cord showed changes similar to those observed in the brain. (3) The lesions were diffuse both in the brain and cord. Anglade regards epidemic encephalitis as the result of a general infection of the nervous system. Histologically this infection is manifested (1) by inflammatory lesions disseminated throughout the cerebro-spinal axis, (2) by focal lesions situated round vascular terminations. The mesencephalon, grey substance at the base or centre of the brain, and the locus niger appear to be the sites of predilection for the formation of these foci.

367. Failure of Antibody Formation in Leukaemia.

KATHERINE HOWELL (*Arch. Int. Med.*, December 15th, 1920) inoculated two patients—one suffering from lymphatic leukaemia and the other from myelogenic leukaemia—with 0.5 c.c.m. of triple vaccine (1,000 million *B. typhosus*, 750 million *B. paratyphosus A*, and 750 million *B. paratyphosus B* per cubic centimetre). The blood count and the opsonin and agglutinin for each bacterial species were examined before vaccination and at intervals thereafter. In the case of lymphatic leukaemia there was no rise of temperature, headache, or other systemic reactions. At no time did even undiluted serum show the presence of agglutinin or opsonin. A control healthy case gave general reactions, and antibodies were present in high serum dilutions after the twelfth day. In the case of myelogenic leukaemia the only symptom noted was a rise in temperature of one degree. Undiluted serum from this patient agglutinated *B. paratyphosus A* and *B* very slightly, but never clumped *B. typhosus*, whilst the opsonin was never above normal. A healthy control showed rise in temperature and general malaise, and his serum gave agglutinins after the tenth day. The observations of other authors on spontaneously infected cases or on those infected with other organisms seem to bear out the contention that the tissues of a leukaemic individual have lost the property of antibody formation in general. The loss of ability to form antibodies is probably the result of the marked alterations in the haemopoietic tissues which characterize leukaemia. This loss of ability may be due to the excessive proliferation of these tissues, one of whose normal functions is the formation of antibodies. With rapidly repeated cell generations the cellular energy used in multiplication prevents the utilization of the energy which is necessary for normal function.

368. A New Method Facilitating Detection of Tubercle Bacilli.

GRYSEZ and BERNARD (*C. R. Soc. Biologie*, December 4th, 1920) describe a new method of treating sputum, pus, faeces, etc., in which it is desired to determine the presence of tubercle bacilli. To the suspected fluid (10 volumes) is added filtered sterilized ox bile (8 volumes), to which two drops of tincture of iodine have been added per cubic centimetre. The mixture is shaken, and becomes completely liquefied after eighteen hours at 37° C., three hours at 56° C., or fifteen minutes at 100° C. After cooling, one-third the volume of saturated salt solution is added, then 2 or 3 c.c.m. of ether. After shaking the mixture is centrifuged (about 6,000 revolutions). By means of a platinum loop fragments are withdrawn from the pellicle which forms at the junction of the watery and ethereal layers. Using this method the authors have found among 73 sputa 23 instances in which a positive result was found in cases which by the ordinary methods appeared negative; tubercle bacilli were found also in 4 cases of cold abscess and 3 of pleuritic effusion.

369. Rate of Sedimentation of the Blood Cells in Tuberculosis.

WESTERGREN (*Acta Medica Scandinavica*, January 26th, 1921) reports favourably on a simple test, the principle of which depends on the fact that the rate at which the blood cells sink in a vertical column of blood is hastened by various diseases, including tuberculosis. He describes in detail the technique of this test, and discusses the results of about 3,000 tests made on 500 persons, 369 of whom were tuberculous. The rate of sedimentation varied greatly in health and disease; it ranged from 1 to 120 mm. per hour; but a rate that exceeded 10 mm. per

hour was invariably associated with some pathological condition. The author found this test of little diagnostic value because in pregnancy and in a host of diseases other than tuberculosis the rate of sedimentation is affected. On the other hand, he found it of great value in gauging the degree of activity of the tuberculosis, for the rate of sedimentation varied directly with the activity of the disease, as determined by clinical examination. Interesting observations were also made as to the rate of sedimentation as determined by injections of tuberculin. The test was more delicate than the measurement of the temperature as an index to the degree of activity of the disease; in some cases the rate of sedimentation began to rise some time before a rise of temperature was demonstrable by the thermometer. The author suggests that this test may indicate a condition which he describes as "fever without rise of temperature." The test was not only of great prognostic importance, but also a valuable guide to the effect of treatment on the course of the disease.

370. Influences on the Metabolism of Bacteria.

The effect of moderate concentrations of disodium hydrogen phosphate (2 per cent.) on the growth of *B. coli*, *Vibrio septique*, *B. welchii*, *B. sporogenes*, and *B. histolyticus* in glucose peptone has been investigated, and the effect of acid potassium phthalate and sodium pyrophosphate on the growth of *B. coli* ascertained by WOLF (*Brit. Journ. Exper. Pathol.*, December, 1920). In all cases the buffer salt either partially inhibits gas production or produces a lag. If the fermentation be very prolonged, the volume of gas may finally approach that obtained from a non-buffered medium. The effect of phosphates on gas production is most pronounced in the case of actively saccharolytic organisms, but is also definite with proteolytic bacteria such as *B. sporogenes* and *B. histolyticus*. The effect of phosphates on the nitrogen metabolism is not pronounced. On the whole the formation of amino-acids and ammonia from a medium containing peptones, polypeptides, and amino-acids is not increased. In the case of the saccharolytic organisms the acid production appears to be increased when buffer salts are added to the medium. This bears out some of the results which have been obtained with similar organisms when fermentation takes place in the presence of calcium carbonate. The final reaction of the fermentations is affected by the presence of buffer salts in the sense that in no case does the medium become so acid in the presence of buffer salts as it does when these salts are absent. The toxin formation in *Vibrio septique* cultures is influenced by the presence of a buffer salt—sodium phosphate. The toxin has a higher potency than the control made without the salt. It is shown that toxins may be kept potent for long periods of time in the presence of sodium phosphate under conditions which would quickly destroy the toxicity of a product made in an unbuffered medium.

371. Cholesterol in Xanthoma Multiplex.

BURNS (*Arch. Derm. and Syph.*, October, 1920) agrees with the more recent histologists in regarding the tumour-like nodules of this disease to be a dermatosis originating in the excessive amounts of cholesterol in the blood, the substance being deposited in the skin, where it induces a secondary connective tissue hyperplasia. Histologically a xanthoma nodule is composed of fibroblasts forming a loose network, within which are large vacuolated cells containing apparently a fatty material. There are many needle-like spaces between the fibrils, which have probably contained cholesterol crystals. About these spaces may be found clusters of foreign body giant cells. On chemical examination large quantities of cholesterol are found. In Burns's case the blood was examined for cholesterol, which was found to be considerably increased under normal mixed diet, under low fat diet, and under high fat diet. Under high fat diet the increase was excessive. It is possible that the occurrence of xanthoma diabeticorum is due not to the presence of sugar but to the associated cholesterinaemia.

372. Preparation of Serum on a Large Scale.

SORDELLI (*Rev. del Inst. Bact.*, December, 1920) describes the following method of obtaining horse serum on a large scale. The blood is collected in a sterile 2.6 per cent. solution of sodium oxalate in distilled water. After forty-eight hours the plasma is withdrawn and coagulated by adding 1.2 to 1.4 gram calcium chloride to every 1,000 c.c.m. of plasma, and the serum is then rapidly strained through a filter. Large quantities can thus be rapidly obtained of a uniform serum which is less likely to give rise to serum disease.

EPITOME OF CURRENT MEDICAL LITERATURE.

MEDICINE.

373. Acute Endocarditis in Children.

LEDFORD (*Amer. Journ. of Diseases of Children*, February, 1921) analyses 250 hospital cases of acute endocarditis in children from the point of view of etiology, symptoms, signs, treatment, and results. Seventy were "mild" cases, the remaining 180 being classed as "severe." Several patients gave a history of tonsillitis, or chorea, or both, in addition to rheumatic fever, and the endocarditis occurring with chorea was found to be much milder than that occurring in either rheumatic fever or tonsillitis. Endocarditis in childhood is largely due to rheumatic fever, and it may be the first manifestation of the infection and be very severe in type with the mildest articular signs. Although 41.6 per cent. did not complain of any cardiac symptoms the most constant were dyspnoea, precordial pain, palpitation, and epigastric pain. Temperature averaged 99.8°. The leucocyte count was much higher in the severe cases and was not influenced by age or degree of fever. The mitral valve was always affected, the aortic being much less frequently involved (namely, 37 instances). The earlier in childhood the primary endocarditis occurs the better is the ultimate prognosis, though the immediate prognosis is much worse in younger children. The duration of the fever is significant, an early permanent return to normal being most favourable, since a long duration of fever means greater cardiac distress. Treatment mainly consists of rest in bed as far as possible consistent with comfort. Severe cases were not allowed even to feed themselves, such strict rest not being relaxed until every sign of the acute infection had subsided, mild cases averaging 30.5 days in bed and severe cases 50 days. Any local foci of infection (for example, in teeth or tonsils) were removed before the patient was discharged from hospital.

374. The Predisposing Causes of Sciatica.

LINDBLADT (*Acta Medica Scandinavica*, January 14th, 1921) was induced to study the static factors promoting sciatica by seeing a patient whose sciatica he associated with an inflammatory pes planus. He then collected from various hospitals in Stockholm 100 cases in which the diagnosis of sciatica had been made by independent observers. Thus there was no bias in the diagnosis. In no less than 91 cases important morbid conditions were found, and they were calculated, in the author's opinion, to favour the development of sciatica. In 14 cases there were disorders of the knee-joint, in 12 a history of rheumatoid arthritis, in 11 disorders of the hip-joint, in 8 considerable varicose dilatation of the veins, in 8 disease of the spine, such as spondylitis deformans or fracture, in 8 pronounced pes planus, in 5 traumatic lesions of the foot, and in 4 marked looseness of the knee-joint with genu recurvatum. Other complications were tumours, salpingitis, fracture of the femur, pronounced genu valgum, deformities of the foot, and constitutional static weakness. In 7 cases the complications were of gonorrhoeal origin. The author gives the following arguments in favour of regarding these complications as causative and not merely coincidental: Whenever they were unilateral they occurred on the same side as the sciatica. The complications were too numerous to be merely coincidental, and many of them were of a noteworthy and comparatively rare type. Sciatic neuralgia due to these causes may be compared with trigeminal neuralgia following toothache or the muscular fatigue induced by presbyopia.

375. Bronchopulmonary Spirochaetosis (Castellani).

LEVY (*New York Med. Journ.*, January 29th, 1921) discusses the three types of bronchopulmonary spirochaetosis first described by Castellani. An acute attack is usually accompanied by chilliness and fever, and lasts for from two to eight days. The cough is pronounced, with scanty mucopurulent sputum rarely containing blood, and rheumatoid general pains may be complained of. A subacute attack lasts from two to several weeks with little or no fever, frequent cough, and the expectoration of pink, jelly-like mucus. The physical signs are those of a simple bronchitis. Chronic broncho-spirochaetosis may follow on either of the above, or have a slow, insidious onset. The symptoms are those of a chronic bronchitis, but at times the sputum may contain blood

for two or three days together. Diagnosis depends upon the result of microscopic examination of the sputum collected after the mouth has been well rinsed out with sterile water, or some antiseptic, in order to remove the possibility of contamination by spirochaetes from a pyorrhoea. The similarity of the symptoms to those of malaria, influenza, and pulmonary tuberculosis makes differential diagnosis at times difficult. Acute symptoms usually disappear after a few days in bed, and in the way of specific treatment arsenic gives better results than any other drug, and considerable success has attended the intravenous use of one of the arsphenamine products. A more careful study of the sputum in chronic cough would possibly bring to light other cases of the disease, since the spirochaete has been found in thirty nine cases out of seventy-nine examined.

376. Treatment of Migraine.

DURAND (*Bull. Soc. de Thér.*, January 12th, 1921) reports the case of a woman who, at the age of 50, began to suffer from attacks of migraine accompanied by urticaria. The attacks became worse in the course of six months, until she had only a few days' relief at a time. After all other methods had failed, Durand had recourse to autohaemotherapy, which he had found successful in several cases of urticaria. A subcutaneous injection of 10 c.cm. of the patient's blood was made during an attack, and four days later the dose was repeated at the onset of an attack, with the result that for the first time for three months the patient was a fortnight without another attack. The next attack was mild, and the following milder still. During the following months only abortive attacks occurred, and were easily cured by subcutaneous injections of 2 c.cm. of the patient's blood.

377. The Date of Onset of Epilepsy.

KLESSSENS (*Nederl. Tijdschr. v. Geneesk.*, November 6th, 1920) brings forward statistics which show that both forms of epilepsy start more frequently at certain definite periods of life than at others. All investigators have found that epilepsy commences most frequently in the first year, about the sixth year, and in the twelfth year. Some observers have also noted a slight increase of frequency at the eighteenth year. On the other hand, there is a considerably smaller number of cases beginning in the fourth year, and the diminution after the eighteenth year is very pronounced. While symptomatic epilepsy regularly declines in frequency after the first year, the diminution in the frequency of the genuine form is more marked after the sixth year, and still more so after the eleventh year. Klessens suggests that the difference in the time of onset may help to distinguish genuine from symptomatic epilepsy.

378. Perforation in Typhoid Fever.

ARCANGELI (*Riv. Osped.*, December 15th, 1920) still believes that the best treatment for typhoid is the cold bath and ice, and under his routine method says his mortality is not more than 2½ to 3 per cent. The chief causes of death are haemorrhage and perforation, hence the great importance of early diagnosis and prompt surgical treatment in perforation. Perforation is not confined to severe cases, although more likely to occur where there is much haemorrhage, but it may happen to an ambulatory case. The three cardinal signs are vomiting, pain, and abdominal rigidity. When there is reason to fear perforation it is well to relieve meteorism by passing a rectal sound, limiting the food, and controlling peristalsis by opium. In patients too ill to notice a sudden onset of pain, tenderness in the right iliac fossa may suggest the possibility of perforation. Very small perforations with hardly any escape of faecal matter, but plenty of gas, may give rise to difficulty in diagnosis. In simple meteorism without perforation, the initial stab of pain, the localized tenderness, and the abdominal rigidity are wanting; other possible sources of error are appendicitis, scybala giving rise to colic in convalescence, cholecystitis (the pain in these cases is in the upper half of the abdomen, where perforation is rare), renal colic, arterio-mesenteric duodenal occlusion, and hysterical mimicry; the author quotes cases illustrating these varieties. He also refers to a specific urine reaction recently described by Sgambati as pathognomonic of acute peritonitis. Absence of liver dullness, lowering of

temperature, rapidity of pulse are useful aids in diagnosis, but all come late and are not certain signs. It is better to do a laparotomy without perforation than leave a perforation without a laparotomy. Brown's stethoscopic sign (hearing a fine crepitant râle in the right iliac fossa) and observation of the position of the patient are too fleeting in duration to be of much value.

379. Subcutaneous Emphysema in Measles.

BERGOLLI (*Il Morgagni*, September 30th, 1920) discusses at some length the conditions associated with subcutaneous emphysema, and describes the case of a child aged 1½ years, suffering from measles and bronchopneumonia, who on the fourth day of the disease developed subcutaneous emphysema, extending to the supraclavicular fossae and to the face (excluding the chin) up to the zygomatic arch, and spreading the next day to the trunk. There was a certain amount of cyanosis and dyspnoea. The emphysema did not entirely disappear until the twenty-sixth day; the child completely recovered. The cough was at no time violent. The author has collected 31 cases of subcutaneous emphysema complicating measles, and 13 of these died (6 also had bronchopneumonia). He speaks highly of the diagnostic value of the stethoscope in discovering and delimiting the area affected by emphysema. A bibliography of thirty references is appended.

380 Spontaneous Recovery from Renal Tuberculosis.

IN 1913 Harbitz published twelve cases showing that, contrary to the established teaching, tuberculosis of the kidney may run a chronic, benign course terminating in caseation with fibrosis. In five of his cases there was complete or partial obstruction of the ureter, which was either converted into a solid fibrous band or was distended by caseous matter. Two further examples of spontaneous recovery from renal tuberculosis are reported from Harbitz's pathological department by his assistant SCHAANNING (*Med. Rev.*, January, 1921), who discusses at length the different criteria by which clinicians and pathologists decide whether tuberculosis is active, latent, or "cured." As both cases terminated fatally with chronic nephritis, and amyloid disease was demonstrable in one case, the author insists that the proof that spontaneous recovery occurs in renal tuberculosis does not warrant the abandonment of operative treatment. He is also of the opinion that cases of spontaneous recovery are comparatively rare, and that in these rare cases the term "recovery" should be used with reserve.

381. The Mental Condition in Paralysis Agitans.

ACCORDING TO CLAUDE (*Paris méd.*, October 2nd, 1920), in most cases of paralysis agitans there are no mental disturbances, properly so-called. The patients merely present a certain slowness of ideation, more or less pronounced depression, and a tendency to melancholy—symptoms which can be explained by the patients' consciousness of their distressing condition. Claude records three cases illustrating, first, the resemblance between certain mental disturbances following lethargic encephalitis and those of paralysis agitans; secondly, the rapid variability of the mental symptoms met with in these two diseases, in which the same subject is very apt to show a quick change from a state of depression to one of merriiment and excitement. Claude is of opinion that the mental disorders of paralysis agitans are the expression of a disturbance of function of the cerebral cortex and of certain lesions of the motor centres which adapt speech to thought. Lethargic encephalitis, in which the anatomical lesions are the same as in paralysis agitans, produces the same motor and psychological syndrome as the chronic vascular changes which appear to be the origin of paralysis agitans.

382. Scorbutic Dysergy.

ABELS (*Wien. klin. Woch.*, October 7th, 1920) states that this term has been given to the diminished resistance of the scorbutic organism to protect itself against infections. This is illustrated clinically by the frequency of gingivitis round carious teeth, the obstinate furunculosis and the extraordinary liability to bronchitis and bronchopneumonia shown by scorbutic patients, as well as by their increased susceptibility and diminished resistance with regard to specific infectious diseases. This diminished resistance is also seen in experimental animals. Intracutaneous injections of staphylococcal cultures to which, as to all pyogenic organisms, normal guinea-pigs are extremely resistant, produced a distinctly haemorrhagic infiltration and an abscess in scorbutic guinea-pigs, whereas these phenomena were entirely absent in animals fed on a diet containing antiscorbutic vitamins.

SURGERY.

383. Operative Treatment for Cancer of the Breast.

BRATTSTRÖM (*Acta Chirurgica Scandinavica*, December 11th, 1920) has investigated the after-histories of patients operated on for cancer of the breast between 1898 and 1915. He experienced great difficulty in tracing these cases, and of the total of 295 patients who survived the operation, 39 could not be traced. As there was no record of their deaths in the parish registers scrutinized, a large proportion of these must be regarded as recoveries. In 136 cases the patients had subsequently died from recurrence of the disease, and in 45 cases there were signs of recurrence. In 75 cases the patients were either still free from recurrence or had died of other diseases than cancer more than three years after the operation. In as many as 22 of these 75 recoveries, metastases were found in the axillary glands at the time of operation, as shown by microscopic examination. The author refers to isolated cases of local recurrence followed by a second operation, radium treatment, and complete recovery. One patient who was operated on in 1911 showed a local recurrence in 1914; she underwent radium treatment and was quite well when examined in 1919, except for a couple of enlarged glands in the supraclavicular fossa. Included among these cases of malignant disease of the breast were 15 of sarcoma; 5 of these patients were still living and well six to seven years after the operation. The author gives details of several cases of special interest, because either simultaneously with the cancer of the breast, or at some later period, they showed primary tumours of other organs.

384 Nerve Stretching in Chronic Ulcers of the Legs.

VOLKMAN (*Zentralbl. f. Chir.*, February 12th, 1921) has treated 12 patients by the method of nerve stretching first introduced by French surgeons twenty-five years ago for the treatment of perforating ulcer, and later by Bardescu and Chipault for ulcers of the legs. In each case the ulcers had been present for a long time (twenty-seven years to two months) and various methods had been tried without any obvious improvement. Three of the patients were men and nine women, the ulcers being in seven cases on the right leg and in five on the left leg. The area of the internal saphenous nerve was most frequently affected, and in all cases this was the nerve stretched. When the outer side of the leg was affected, the area of the external popliteal nerve was involved, when the lesion was deeply situated that of the superficial peroneal, and in circular ulcers that of the medial cutaneous nerve. In elderly persons the operation was performed under spinal anaesthesia, and in younger persons under a local anaesthetic. Of the 12 cases 9 were cured, 1 was discharged improved, and 2 were still under treatment. The operation was in most cases followed by an immediate improvement. All the patients were given the same ointment before and after the operation, and were kept strictly in bed.

385. Renal Calculi in Soldiers.

GAUTHIER (*Journ. d'Urol.*, October, 1920), who was formerly in charge of an army urological centre, states that among 918 cases in hospital or the out-patient department he diagnosed calculi in 10 cases and suspected their presence in another 10 cases. The diagnosis was most difficult in cases of aseptic lithiasis, in which there was no pus to suggest the presence of calculi, and where the stones were small and often composed of urates. Gauthier classifies his cases in two groups: The first consisted of four patients with aseptic calculi, who were placed in the auxiliary service owing to the frequency of renal colic. The second group consisted of six cases of infected lithiasis, in one of which he performed nephrolithotomy, in four nephrectomy, and in one partial excision of a very adherent pyonephrotic sac. The cases of infected lithiasis put up with their pyuria for a long period, probably owing to the slight degree of involvement of the bladder. One patient who had phosphatic calculi, the total weight of which was 104 grams, was able to serve in Macedonia for fifteen months. There was a great difference in this respect between these cases and patients with renal tuberculosis, who soon reported sick owing to early cystitis. All the cases on whom an operation was performed were recommended for discharge from the army, especially as three at least had slight lesions in the opposite kidney. In three cases discharge from the army or service in the auxiliary forces was recommended on account of pyelonephritis, verified by catheterization of the ureters.

386. **Diagnosis of Gastric Ulcer.**

HARDISTY (*Canadian Med. Assoc. Journ.*, January, 1921), reviewing the several means of diagnosis in gastric ulcer, shows that no single means by itself is pathognomonic, but a careful study of all the conditions together is necessary to arrive at a conclusion. In addition to a careful clinical examination very great importance attaches to an accurately weighed history. An account of the pain and its remissions, the vomiting and bleeding, and the downward progress, when considered with x-ray findings, will generally confirm the diagnosis. Pain and tenderness are constant symptoms, and although hyperacidity is generally thought to be fairly constant in gastric ulcer, in many cases the acid may be normal or even subnormal. The finding of occult blood in the faeces probably indicates the presence of a gastric ulcer, though its absence does not exclude the possibility. The barium meal and x-ray findings, with simultaneous palpation of the stomach while the patient is screened, are useful, though some cases of gastric ulcer show no x-ray changes.

387. **Gangrene of Erectile Tissue.**

ACCORDING to MINET (*Journ. d'Urol.*, October, 1920), gangrene of erectile tissue may assume the following clinical forms: (1) The commonest is gangrene of the corpus spongiosum, which is responsible for circumscribed or more frequently diffuse periurethral inflammation, and is favoured by hyperaemia and coagulation of blood within the fibrous coats of the corpus spongiosum. (2) Gangrene of the corpus cavernosum on one or both sides is rare, and is usually a complication of urinary phlegmon, to the symptoms of which it adds pseudo-priapism and rapid septicaemia, or a slower but often fatal pyaemia. (3) Gangrene of the glands may be a complication of the preceding form, but is usually the result of a cutaneous lesion. (4) Fulminating gangrene of erectile tissue is usually the result of an initial thrombosis. It must not be confused with the spontaneous fulminating gangrene of the external genitals described by Fournier, which is superficial. The general condition is little affected in spite of the intensity of the lesions. The starting point may be a focus of periurethral or prostatic infection.

388. **Intestinal Tuberculosis.**

CAIRD (*Edin. Med. Journ.*, February, 1921), from a study of 43 consecutive cases of intestinal tuberculosis, concludes that tubercle is a common affection of the intestinal tract, either as an acute destructive or as a chronic formative type. The former is the more usual and is secondary to pulmonary phthisis from direct infection by swallowed sputum. Characterized by extensive intestinal ulcerative lesions, with diarrhoea, it becomes a manifestation of advanced phthisis, and is rapidly fatal. The chronic formative type is less common, and infection occurs through the blood or lymph stream, giving rise to localized hyperplastic strictures causing obstruction and necessitating operative treatment. There may be little or no pulmonary mischief. The lesions in both types are usually at the ileo-caecal region, the appendix and lymph glands being involved. Tuberculous nodules develop in the submucous and subserous layers and give rise to ulceration, perforation, or the formation of faecal fistulae; but in the second type perforation is rare on account of the great proliferation of connective tissue. Definite symptoms may not arise for some time until signs of obstruction occur. Diagnosis may be difficult, but the chronicity of the ailment and the family and personal history of tubercle may help, though cases with a relatively short history cannot easily be discriminated from subacute appendicitis, while in others malignancy is simulated. Treatment aims at free and complete resection of the affected area, generally including the ileo-caecal region, but there is not the same need for removal of all enlarged glands as in carcinoma. Short-circuiting should be reserved to overcome destruction when excision is impracticable. The mortality after lateral anastomosis is not so great as that after excision, but it should not replace the latter unless the condition of the patient precludes it.

389. **Mastoiditis and Pott's Disease.**

It might be thought that there could be but little difficulty in differentiating between mastoiditis and Pott's disease. PORTMANN (*Rev. de Chir.*, September, October, November, 1919) in an exhaustive study shows how error can be avoided. The difficulty is only likely to arise when the inner wall of the mastoid gives way and pus collects in what Portmann calls the "cranio-cervical gutter." The differential diagnosis of inflammation in this area with and without abscess and sinus formation is fully discussed. Recognition of Portmann's principles should obviate all possibility of mistake.

OBSTETRICS AND GYNAECOLOGY.

390. **Late Results of Hysterectomy for Cancer of Cervix.**

SCHWEITZER (*Zentralbl. f. Gynäk.*, March 5th, 1921) records the after-history of 41 cases of corporeal and 281 cases of cervical cancer treated by the Wertheim-Zweifel abdomino-vaginal operation, with a primary mortality of 4.7 per cent. It was possible to trace the after-history of all the cases, 177 in number, of cervical cancer operated on from 1910 to 1915; of these, 12 had died immediately after operation, and 92 had remained free from recurrence for at least five years. The remainder (77) had died from inter-current disease (2 cases), or had shown recurrence of the malignant condition (75). Recurrences took place in the first year in 46 per cent. of fatal cases, during the first three years in 83.1 per cent.; in three cases only was recurrence observed after the fifth year. Turning to prognosis as based on the condition of the pelvic glands at operation, Schweitzer reports that unilateral enlargement was encountered in 97 cases; of these, the glands were removed in 52, with 26 cases of lasting (five years) cure. Bilaterally enlarged glands were removed in 36 cases, of which 13 showed no recurrence. Two among seven cases in which enlarged glands were left *in situ* remained cured after five years. Only 53.6 per cent. of the enlarged glands removed were found on microscopic examination to be carcinomatous; five patients from whom such carcinomatous glands were removed were found to be healthy five to ten years after operation. Allowance being made for the primary mortality, the percentages of lasting cure obtained by the unmodified Wertheim operation and by the Wertheim-Zweifel technique are given as 54.5 and 46.5 respectively.

391. **Maternal Mortality in Childbirth.**

PURDY (*Med. Journ. of Australia*, January 15th, 1921) gives some interesting statistics on maternal mortality. He compares the figures for 1911-14, which were 4 per 1,000 in England, with those of New South Wales, which were 7 per 1,000 for the same period. In both, one-third of the deaths were due to puerperal fever. He considers that the remedy for this high mortality is a greater supervision of midwives by means of a Midwives Act, which is at present lacking in Australia, and by making puerperal sepsis a notifiable disease. He points out that of recent years the practice of midwifery has been passing more and more into the hands of midwives, and that the medical practitioner is becoming more and more a consultant as far as childbirth is concerned. He quotes Williamson (British Medical Association Annual Meeting, Cambridge, 1920) to the effect that obstetrics is essentially a branch of preventive medicine, and that the dangers of childbirth are to a great extent preventable.

392. **Placenta Praevia.**

GONZÁLES (*Semana Med.*, 1920, xxvi) records 8 cases of placenta praevia, with severe haemorrhage, treated by a vaginal Caesarean section, which he still regards as preferable to the abdominal method. There was no maternal mortality and of the children one only (who weighed just under 8½ lb.) died.

PATHOLOGY.

393. **Studies in Properties of Blood Platelets.**

The increasing difficulty in obtaining brilliant cresyl blue led BUCKMAN and HALLISEY (*Journ. Amer. Med. Assoc.*, February 12th, 1921) to search for another dye that might be used for the vital staining of blood. After experimenting with a large number of dyes, they finally adopted as the most satisfactory, easily procurable vital stain crystal violet—pentamethyl pararosanilin hydrochloride. This dye, like brilliant cresyl blue, stains the leucocytes deep blue. The platelets and the reticular substance of young erythrocytes, which also are stained blue by brilliant cresyl blue, are stained a deep lilac by crystal violet. Haemoglobin is stained but faintly. The percentages of reticulated cells in twenty-nine different cases counted by Robertson's method, using both brilliant cresyl blue and crystal violet, were substantially the same in every case. In fresh preparations a rough estimate also may be obtained of the number of platelets as satisfactorily with crystal violet as with brilliant cresyl blue preparations. A method for the counting of platelets is described which it is asserted is superior to other methods.

The blood is collected in a miniature transfusion tube and is diluted to the 101 mark with a fluid containing 6 grams glucose and 0.4 gram sodium citrate dissolved in 100 c.cm. of distilled water. To this are then added about 0.02 gram toluene red—dimethyldiamidotoluphenazine—sometimes also called "neutral red," and 0.1 gram of crystal violet. The solution is gently heated to 60° C., and held at that temperature for five minutes. It is allowed to cool slowly to room temperature, and centrifuged for ten minutes at 2,000 revolutions a minute. The supernatant liquid is then filtered twice, each time through three thicknesses of No. 30 Whatman filter paper (dry). The solution is preserved by adding 0.2 c.cm. of formaldehyde solution, and then keeps indefinitely. The method yields counts generally slightly higher than those obtained by the other methods, and especially so when the number of platelets is great. By this method simultaneous determination of platelets, red cells, and white cells may be made. It gives results for all three of the formed elements of the blood which closely parallel those obtained by standard methods.

394. Studies in Cyanosis.

LUNDGAARD (*Acta Medica Scandinavica*, January 14th, 1921) has measured the O₂ and CO₂ content of the venous blood of about 100 persons, some of whom were cyanosed. He could find no relation between the CO₂ content of the blood and the cyanosis present, nor between the cyanosis and the absolute O₂ content of the venous blood. On the other hand, he succeeded in proving the existence of an increased quantity of non-oxidized haemoglobin in the venous blood of cyanosed persons. In normal persons the non-oxidized quantity of haemoglobin was, on the average, 5.5 volumes per cent., varying from 2 to 9 volumes per cent. In cyanosed persons, on the other hand, these figures ranged from 8 to 20 per cent. It was not possible to establish any definite relation between the severity of the cyanosis and the quantity of non-oxidized haemoglobin. The author concludes that cyanosis is caused by an increase of the amount of reduced haemoglobin in the blood, and that the threshold at which cyanosis appears is 6 or 7 volumes per cent. By the measurement of the amount of non-oxidized haemoglobin in the blood of persons with cyanosis important conclusions can be drawn as to the degree of oxidation in the lungs, and the effect of oxygen inhalation and venesection in cyanosed persons can be studied. The author's technique has been described in the *Journal of Biological Chemistry*, 1918, vol. xxxiii, p. 1.

395. Primary Tumour of the Pleura.

DU BRAY and ROSSON (*Arch. Int. Med.*, December 15th, 1920) report a case of these very rare tumours. Apart from occasional benign tumours, such as lipomas, fibromas, and chondromas, true malignant neoplasms originating in the pleura are divided into sarcomas and endotheliomas. The authors call their tumour a "mesothelioma." At autopsy it was found to fill the left pleural cavity, invading the left lung and pericardium, extending through the diaphragm and extensively invading the omentum, with superficial invasion of the spleen and liver. Small nodules of implantation occurred all over the peritoneum. Microscopically the cell type and manner of growth was variable, apparently depending on the environment. In places where no hampering influence was at work the cells were of medium size, spherical in shape, with a homogeneous eosinophilic cytoplasm, a relatively large round vesicular nucleus and small faint nucleoli. This type was found specially in lymphatic vessels. Where the cells were grouped together they assumed the appearance of epithelial growths. At other parts the cells were isolated and diffused through the connective tissue, and then were more like fibroblasts. Occasionally multinucleated masses were found. Though admitting that the tumour was too far advanced to determine definitely its point of origin, the authors consider that as the tumour growth was distributed over the costal pleura so diffusely it arose from this surface and secondarily involved the visceral pleura and the adjacent lung. In view of the fact that it did not possess the general characteristics of endotheliomas arising from lymphatics and blood vessels, Du Bray and Rosson prefer to label it a mesothelioma arising from the lining mesothelium of the pleura. It ought to be pointed out that there are no general characteristics of endotheliomata on which pathologists are agreed—in fact, the term endothelioma is generally avoided by the best authorities. There is nothing in this case, nor, indeed, in any of the so-called primary tumours of the pleura, to convince one that the tumour did not originate from the alveolar epithelium of the lung itself.

396. Bacteriology of Dysentery.

KIRSCHNER and SEGALI (*Wien. klin. Woch.*, December 23rd, 1920) record their bacteriological investigations during an outbreak of dysentery in Vienna in the summer of 1920. The first examinations which were made on stools sent to the laboratory had a very unsatisfactory result, as out of 178 specimens only 11, or 6 per cent., showed dysentery bacilli. The writers therefore decided to visit the hospital and examine the stools directly after they were passed, with the result that out of 487 specimens 189, or 39 per cent., were positive. Finally, 86 specimens were obtained by rectoscopy, and 56 of these, or 65 per cent., were positive. The epidemic showed a by no means uniform etiology, for of the 256 positive specimens 120 showed bacilli of the toxic group (*Shiga-Kruse* type), 124 bacilli of the mannite-fermenting type (*Flexner*, *Strong*, and *Y* types), and 12 bacilli of the Schmitz type.

397. The Occurrence of Spirochaetes in the Urine in Secondary Syphilis.

FISSINGER and HUBER (*Bull. et Mém. Soc. Méd. des Hôp. de Paris*, February 17th, 1921) remark that it is very easy to mistake the various forms of spirochaetes found in the meatus and terminal portion of the urethra in the male, and still more frequently in the female, for the *Treponema pallidum*. In persons with long foreskins a large quantity of spirilla are present, mostly belonging to the type of *Spirochaeta refringens*, though other groups may also be found, such as *Treponema minutum* and *Treponema calligyum*. Careful washing of the glans and meatus with boiled water and permanganate, reception of the urine from the middle of micturition in a sterile test tube, centrifugalization and immediate examinations are necessary precautions. Lévy and Guilhé examined the urine in 24 cases of syphilis at different periods of the secondary stage, and in only one case, in which two typical treponemata were present, was the result positive. In 13 cases examined by Fieessenger and Huber the results were always negative with one exception. The writers conclude that *Treponema pallidum* may be excreted in the urine in exceptional cases in secondary syphilis, but that the investigation requires a careful technique. The presence of the organism may be associated with a normal renal function (Lévy and Guilhé), severe syphilitic nephritis (L. Hoffmann), or slight albuminuria with a rise of Ambard's constant, as in the writers' case.

398. Adenoma Sebaceum and Renal Tumours.

CRUTCHFIELD (*Arch. Derm. and Syph.*, September, 1920) reports a case which may be classed with those from time to time reported showing the curious association of adenoma sebaceum with various congenital tumours. In this instance the patient was a married woman of 27 who had had from her childhood numerous small nodules of adenoma sebaceum on each side of the nose, on the cheeks, and on the forehead. An acute illness set in with high temperature and rapid pulse, nausea and vomiting, and continuous pain in the left side. The left ureter contained much blood. A tumour mass extended from the costal margin to the pelvic brim. The patient died, and on *post-mortem* examination there was found a large tumour of the left kidney adherent to the diaphragm and lumbar muscles. Microscopically it consisted of smooth muscle, fat, and larger areas of sarcoma—in short a teratoma of the kidney.

399. Blood Cultures in Bubonic Plague.

TEISSIER, TANON, GASTINEL, and REILLY (*Bull. et Mém. Soc. Méd. des Hôp. de Paris*, February 17th, 1921) examined the blood of 20 patients admitted to the Claude Bernard Hospital with buboes supposed to be due to plague, and obtained the following results: (1) In 8 cases in which the other laboratory tests were simultaneously negative the blood cultures were also sterile. (2) Of 12 cases in which the diagnosis of plague was established bacteriologically, namely, by presence of Yersin's bacillus in the pus or serum of the glands, inoculation into mice and cultures from the glands, the blood cultures remained sterile in 3, and in 9 were positive. The writers, from a study of their cases, came to the following conclusions: (1) The presence of Yersin's bacillus in the blood is the rule during the first days of the disease. (2) The mildest forms may be associated with bacillaemia. (3) The bacillaemia present in the mild forms of bubonic plague must be distinguished from the primary or secondary plague septicaemia which is the rule in grave forms with multiple visceral lesions. (4) Cultivation of the blood is a valuable addition to the bacteriological diagnosis of plague.

EPITOME OF CURRENT MEDICAL LITERATURE.

MEDICINE.

400. Prognosis of Nephritis in Childhood.

A STUDY was undertaken by JAMES (*Journ. Amer. Med. Assoc.*, February 19th, 1921) to determine (1) how many patients that had had acute nephritis recovered entirely; (2) how many developed the chronic type; (3) the present condition of the chronic type, and (4) the ultimate prognosis. Sixty-seven children who had had nephritis in the last sixteen years were examined. The examination included the cardio-vascular system, haemoglobin, urinalysis, present health of the child, record of the patient's condition while under treatment, and the etiology. Nine of the 67 cases, or 13.3 per cent., terminated in the chronic type, and of these only 2 could be considered severe. All of the 67 patients who had had acute nephritis are living under normal conditions, on ordinary diet; and in every case the urine was found to be negative. Of 12 fatal acute exudative cases, one patient had an associated tuberculous peritonitis and one died of terminal pneumonia. Ten had general oedema, 2 died of uraemic convulsions; one patient having acute suppression of urine died following a decapsulation; one had associated acidosis. The point to be noted is that in none of the cases of the haemorrhagic type without oedema did the patients die in the acute stage of the disease. In the group of 12 chronic cases, 8 had albuminuria. In the urine of two patients, seen two years after discharge, a few red blood cells were found under high power. James believes that many patients with mild chronic nephritis recover. Diseased portions may recover even if there is considerable degeneration, and neighbouring portions of the kidney may hypertrophy and carry on the extra work. In other words, an anatomically imperfect kidney can function efficiently. Many children will stand severe infections without acute exacerbations of nephritis, but they are more prone to follow upper respiratory infections. For this reason all foci of infection should be treated, such as diseased tonsils, carious teeth, and otitis media (acute or chronic). They act as a reservoir of toxic material which the kidneys drain.

401. Prophylaxis of Hay Fever.

DEWEILER (*Canadian Med. Assoc. Journ.*, January, 1921) discusses the present-day conception of hay fever. In sensitive subjects the placing of the offending pollen upon the slightly abraded skin will cause a local reaction by the appearance of a wheal with a surrounding area of erythema. By this method of diagnosis the specific protein causing the disease can be ascertained, and the greatest success in treatment follows the prophylactic inoculation of the patient with a solution of the pollen protein. After grading the dilutions from 1 in 500 to 1 in 20,000, a preliminary skin test is made by placing a drop of the dilution upon a scratch and giving hypodermically as an initial dose 0.1 c.c.m. of the dilution next higher than the one giving the positive skin test. Treatments should be given weekly, and should be completed by the time the attack is expected, so that the course of injections should begin three months before that time. Such a course should protect for a season, but it should be repeated each year for a few years. A change to a climate free from the offending pollen will be useful.

402. The Demonstration of Pleural Adhesions.

SAUGMAN (*Hospitalstidende*, January 19th, 1921) regretfully concludes that it is practically impossible to demonstrate the presence of pleural adhesions even when every diagnostic device is employed. He used to think that when there were marked excursions of the lungs, as determined by physical signs, and when the diaphragm was freely movable, both its vault and its circumference showing normal excursions, then the lung could not be adherent to the neighbouring structures. He found, however, that these signs could be present when the lung was adherent to the chest wall by means of a fine network of cobweb-like adhesions, which, though they allowed remarkably free movement of the lung on respiration, still prevented the effective collapse of the lung when gas was introduced into the pleural cavity. On the other hand, when the stethoscopic and x-ray examination, as well as the history of the case, pointed to complete obliteration of

the pleural space, he often found it perfectly free. In two cases he heard well-marked "friction" sounds, from which he concluded that the lung was not adherent at a certain point. In both cases, however, the lung proved to be firmly adherent at this point, and the sounds heard could not have been due to friction of one rough surface against another, but to creaking in the adherent area. The author admits that only by exploratory puncture can the presence or absence of pleural adhesions be demonstrated.

403. The Treatment of Pernicious Anaemia by Splenectomy.

FIFTY cases in which operation was performed more than three years ago are reviewed by GIFFIN and SZLAPKA (*Journ. Amer. Med. Assoc.*, January 29th, 1921). The immediate operative mortality of the series was 6 per cent. The deaths occurred in the first nineteen cases. The reduction of mortality is ascribed chiefly to more careful pre-operative treatment and the exclusion of the anemias of the more acute type. Forty-two of the forty-seven patients who recovered from operation have died. Ten (21.3 per cent.) lived longer than three years, while twenty-one (45 per cent.) lived longer than eighteen months after operation. Five (10.6 per cent.) of the forty-seven patients who recovered from operation are alive. Two were splenectomized four years and nine months ago, one four years and eight months, one four years and five months, and one four years and three months. These five patients at the time of their last reports were in good general condition. The pre-operative history of these patients in each case was approximately one year; the total average duration of the disease was considerably more than five years. Including with these the patients who survived operation at least three years but who are now dead, there is a total of ten (21.3 per cent.) in whom the total duration of disease before and after operation was four and a half years or more. This is clearly longer than the average expectation of life of patients with pernicious anaemia, and would seem to lead to the definite conclusion that life is prolonged in a considerable percentage of cases. On neurological examination before operation, twenty-nine patients (58 per cent.) showed definite evidence of sclerosis of the spinal cord. Eight more (16 per cent.) registered complaints suggestive of early involvement of the spinal cord, making a total of thirty-seven patients (74 per cent.). Marked degeneration of the cords has not progressed in patients in whom the degeneration was slight previous to splenectomy. It is possible that the progress of the degeneration is arrested in some of the patients. Mental symptoms have not developed following operation. In the selection of patients for operation in this series preference was given to persons between the ages of 35 and 45, with a previous history of one year or less, a favourable type of blood picture, and with little if any evidence of degeneration of the spinal cord. An absence of marked leucopenia with a polymorphonuclear rather than a lymphocytic predominance in the leucocyte count, marked haemolytic activity, estimated by the examination of the pigments in the duodenal contents in the presence of a competent bone marrow and a moderately enlarged spleen, were regarded as favourable to splenectomy. Patients in acute exacerbations and patients showing evidence of bone marrow exhaustion were excluded so far as possible. The histories of the surviving patients are given in full.

404. Laryngeal and Pharyngeal Crises in Influenza.

CURSCHMANN (*Deut. med. Woch.*, February 10th, 1921) gives an account of laryngo- and pharyngo-spasm as a sequel to influenza. Two of the patients whose histories he gives were professors of medicine, the author himself being one. Another patient was a nurse, aged 52, and there were two other patients, aged 35 and 41 respectively. In the author's own case the attacks occurred at night, and he used to awake with a fit of coughing and a sensation of being throttled. For a few seconds he could not breathe. The regular prophylactic administration of codeine gradually aborted these attacks. Discussing their etiology, the author notes that tabes, tetany, polynneuritis, bronchial asthma, whooping cough, and neuroses could be excluded in every case. In all but one case the laryngoscopic picture was normal except for slight redness and injection. Clinically the condition closely resembled the laryngeal and pharyngeal crises of tabes; but whereas in tabes the central end of the vagus is involved, it is

probable that in influenza this condition is due to involvement of the terminations of the vagus in the pharynx and larynx. A curious accompaniment to this spasmodic condition was irrepressible aerophagia which led to very disagreeable distension of the gut. The author emphasizes the importance of distinguishing this condition, the prognosis of which is good, from disease of the central nervous system, such as tabes.

405. Diagnosis and Prognosis of Persistent Ductus Arteriosus.

ACCORDING to BUDDE (*Zentralbl. f. inn. Med.*, February 12th, 1921), the diagnosis of persistent ductus arteriosus may be established by the following considerations: (1) The history of a congenital heart disease; (2) entire absence or late occurrence of cyanosis, which is usually not of a very high degree; (3) moderate enlargement of the heart; (4) visible pulsation and a palpable thrill in the second left intercostal space; (5) loud systolic and occasionally also diastolic murmur in the second left intercostal space conducted into the vessels of the neck and interscapular space; there is also a greatly accentuated second pulmonary sound; (6) on very deep inspiration there is a diminution of the murmur and pulsation. The prognosis as regards life is not very unfavourable, as there is at least one case on record of the patient reaching the age of 58. As a general rule, however, a disturbance of compensation occurs as the result of strain, intercurrent disease, or during puberty, and the condition then resembles ordinary heart disease with failure of compensation. It should be noted that a pulmonary artery which is constantly under a high pressure is very liable to sclerotic changes. Moreover, endarteritic processes, as Wagener, Rickards, and others have shown, have a special tendency to develop in or around a patent ductus arteriosus, which therefore forms a *locus minoris resistentiae*. Rupture of the patent ductus arteriosus may also occur.

406. The Incidence and Treatment of Cerebro-spinal Syphilis.

HANSSEN (*Acta Medica Scandinavica*, January 14th, 1921) is greatly impressed by the comparative frequency of cerebro-spinal syphilis in Bergen, where, in 1917 and 1918, among 2,464 patients, Wassermann's reaction was carried out in 440 cases, and was found to be positive in 96. In 53 of these 96 cases cerebro-spinal syphilis was diagnosed, tabes and general paralysis being included in this category. The author gives the three following possible explanations for this high rate of cerebro-spinal syphilis: (1) In 1898, the year of an exhibition in Bergen, there were extraordinarily many cases of syphilitic infection. The cerebro-spinal syphilis two decades later may be the sequel to this crop of infections. (2) Cerebro-spinal localization of syphilis may have been promoted by salvarsan treatment. (3) Bergen being one of the busiest ports in Europe during the war, the number of sailors among the syphilitic was very high, and in this class the incidence of cerebro-spinal syphilis is remarkably great. Thus 25 per cent. of the sailors admitted to an asylum in Bergen suffered from general paralysis, whereas of the total number of lunatics admitted in a ten-year period only 3 per cent. suffered from general paralysis. The author advocates supplementing salvarsan treatment with mercury and potassium iodide. He has nothing good to say of the intrathecal administration of neo-salvarsan.

407. The Etiological Relationship between Congenital Anomalies and Hereditary Syphilis.

DE STEFANO (*La Pediatria*, January 31st, 1921) examined 272 cases of congenital anomalies and malformations at the Naples University Paediatric Clinic for the presence of hereditary syphilis, the presence of which was determined by the history, association of other morbid symptoms, and the results of the Wassermann reaction carried out simultaneously on the children and their parents. The cases included 54 of hydrocephalus, in which syphilis was found in 50; 23 of spina bifida, 9 of which were positive; 32 of congenital heart disease, 27 of which were positive; 69 of hypothyroidism, 59 of which were positive; 46 of mongolian idiocy, 34 of which were positive; and 17 pluriglandular syndromes, of which 15 were positive. The cases thus show the great frequency of congenital syphilis in the etiology of congenital anomalies and malformations, although it is not the exclusive cause. This is a matter of very great importance, especially from the prophylactic standpoint, because a rational treatment of syphilis in the parents, combined with a careful hygiene of pregnancy, ought to prevent to a certain extent the occurrence of a large number of congenital defects.

SURGERY.

408. Fate of Transplanted Bone.

LERICHE and POLICARD (*Lyon Chir.*, July-August, 1920) make an important analysis of the fate of transplanted bone. They point out that a bone graft is not a true graft, because the actual bony tissue transplanted always dies. This death is invariable, however good the conditions may be. It is true that sometimes a few bone cells may survive beneath the periosteum, but even then the whole of the rest of the bone dies. Many surgeons argue that the transplant survives as a living graft, because on re-exploration they have found the bone well vascularized and bleeding readily when cut, because the transplant has perhaps fulfilled its therapeutic purpose and is fixed at its extremities, because it has increased in size, because it has consolidated after fracture. Leriche and Policard believe that these arguments have not the least value. There is in all this an appearance of life only; the sole criterion is histological examination, and by this standard all bone grafts die. The authors state that there are only three possible fates for transplanted bone: elimination, toleration, absorption; of these the last is the common one. Capillary buds grow into the Haversian canals and enlarge their lumina, revascularizing the bone, making it spongy and permeable. Thus compact bone, crest of the tibia, and segments of fibula are by no means the best material for transplanting. The process of absorption is only delayed, it cannot be obviated. Fractures of the graft are very common, occur even in limbs perfectly immobilized by apparatus, and are often unrecognized. In one of the authors' cases three fractures occurred in one year, but united and left no trace. Concurrently with the bone absorption, layers of new bone are laid down and these not only within the actual area of the transplant but especially in its neighbourhood. The process is one of new bone formation and not one of growth of the transplant *in situ*. Dead bone should do as well as fresh autogenous bone; but, as the authors point out, the beef and horse bone used is too thick and compact, and resists vascularization too long. They lay stress on the retarding influence of fibrous tissue owing to its relative anaemia, and on the importance of obtaining good apposition at the ends of the transplant. These observations are based on an examination of bone removed from 15 transplantations, and on the clinical findings in 29 bone-grafts done by themselves.

409. Oesophageal Stricture.

AUSTONI (*Archiv. Ital. di Chirurg.*, December 20th, 1920), as the result of a somewhat exceptional experience in the treatment of oesophageal stricture (chiefly of traumatic origin), says that surgical treatment should be started as early as possible. The stricture should be dilated with sounds; if high up in the oesophagus, the oesophagoscope should be used and sounds passed through the mouth; if at the lower end, it is better to use the gastroscope and pass instruments the reverse way—namely, through the stomach. Where the lesion is extensive it is well to practise intubation at the outset, and this is better done through the stomach. Absolute stenosis is extremely rare, usually a guide can at least be passed through the stricture. When passing sounds through the stomach, the cardiac opening can be found more easily if a little milk is swallowed. In old strictures treatment may have to be continued for three or four months, but in recent cases a shorter time is sufficient. After cure is obtained, an instrument should be passed every month for about a year. Injections of fibrolysin seem to assist the progress of the cure.

410. Chronic Appendicitis.

CONNELL (*Med. Record*, February 5th, 1921) shows that certain cases of so-called chronic appendicitis are due to causes other than the appendix, the symptoms not being relieved by appendicectomy. The pain and tenderness in the right iliac fossa may not be due to adhesions, and the cause of the symptoms would seem to be more central than in the appendix itself, either in the mucosa or wall of the caecum or colon, the ileo-caecal valve, the root of the mesentery, or even still more centrally in the vagus or sympathetic nerve supply, or in the ductless glands. The previous history as to earlier attacks is important, and supposed cases of chronic appendicitis may be subdivided into those with and those without a history of a previous attack, and a more careful physical examination and consideration of all the facts is strongly urged before an operation is undertaken for a so-called chronic appendicitis.

411. Sapheno-femoral Anastomosis.

MANTELLI (*La Clin. Chirurg.*, May, 1920) discusses Delbert's sapheno-femoral anastomosis operation for varicose veins of the internal saphenous. After discussing the technique, immediate and remote results of the operation, and the literature of the subject, he says the indications for the operation are: (1) Good general condition of the patient; (2) varicose veins of the internal saphenous; (3) presence of Trendelenburg's sign; (4) varices of recent formation where the veins have kept to some extent their elasticity and contractility; (5) perviousness of the saphena and absence of all sign of inflammation. The author has performed 9 sapheno-femoral anastomoses with the following results: Anatomical and functional cure, 1; functional but only partial anatomical cure, 3; functional cure only, 2; doubtful issue, 1; bad results, 2. Of the bad results, one was owing to the presence of varices in the branches of the external saphenous vein (not recognized before operation in 1912), and the other was due to the onset of deep varicose veins a few months after the operation in a patient who had already suffered from phlebitis secondary to typhus. When the internal saphenous vein and its branches are alone affected the operation is an ideal one.

412. Extension of Renal Tuberculosis.

CRABTREE (*Arch. of Surg.*, November, 1920) has studied the lymphatic spread of tuberculosis within the kidney. It is generally recognized that a primary tuberculous patch in the kidney is almost invariably situated in the region of the medullary portion at the base of a pyramid. Extension causes it to burst into the pelvis of the ureter, which is nearer than the cortex. A tuberculous pyelitis is now instituted, and is sufficient in itself to justify nephrectomy. Tubercle bacilli are found in greatest numbers in the recesses of the calyces, these being backwaters of urinary irrigation. From the pelvis a reinvasion of the kidney parenchyma occurs, probably along the lumen of the tubules. Crabtree has repeated Ekelhorn's work and confirms it. He has found in apparently normal portions of the cortex, remote from the primary focus, microscopic tubercles just beneath the true capsule. As he could find no connexion between these tubercles and the deeper parts of the renal substance, he believes them to have originated from a lateral extension by the cortical lymphatics. He believes, however, that with these cortical tubercles as a starting point secondary tubercles may form in the renal cortex, and that these may be of considerable importance in encompassing the destruction of the kidney.

413. Tuberculosis of the Ear.

LERMOYER (*Ann. des mal. de l'oreille*, vol. xl, Nos. 10-12), after stating that tuberculosis of the external ear is usually confined to the pinna, and that tuberculosis of the internal ear is exceptional, confines his attention to tuberculosis of the middle ear. The apparent difficulty in the diagnosis of tuberculosis of the middle ear is due to its insidious character and its protean manifestations. The disease may develop in persons who are in apparently good health, in whom it assumes the appearance of an ordinary otitis media. It is important to realize that every case of tuberculous otitis does not necessarily occur in a phthisical subject. On the other hand, only 60 per cent. of the cases of otorrhoea in phthisical patients are tuberculous. The protean manifestations of tuberculosis of the middle ear are as follows: (1) Otorrhoea, which is its ordinary symptom, corresponds to at least four distinct types of lesions of the middle ear, which Brieger designated as lupoid, infiltrative, fungous, and necrosing types respectively. (2) The appearance of the tympanum is often but not always characterized by multiple perforations. Sometimes the otoscope shows a small number of phlyctenules (acute miliary tuberculosis of the tympanum) or, on the other hand, a soft yellowish swelling (chronic tuberculous myringitis). (3) Tuberculosis may produce an osteo-periostitis of the mastoid process, which sometimes has such a slow course that it has been attributed to the bovine type of the tubercle bacillus. (4) Suppuration of any kind may be absent, and the resulting dry tuberculous otitis behaves like an acute or chronic catarrh of the tympanum. The complications of tuberculous otitis media are labyrinthine paralysis, facial paralysis, perforation of the internal carotid, and external pachymeningitis. The prognosis is grave, partly owing to these complications and partly owing to tuberculous lesions in other organs. It is worst in early life, especially in infants. Relapses are frequent.

OBSTETRICS AND GYNAECOLOGY.

414. A Sign of Pregnancy.

DEZWARTE (*Proc. Acad.*, February 12th, 1921) describes a sign which is based on the position of normal equilibrium and normal mobility of the uterus, and is therefore absent in cases of deviation or abnormal fixation of the organ. In the normal state the uterus is anteflexed, and on vaginal examination the finger successively distinguishes the anterior lip of the cervix, the external os, the posterior lip, and the posterior vaginal cul-de-sac. Just before menstruation and in pregnancy the uterus becomes retroflexed, and on vaginal examination the os externum will at once be encountered, as it is now in the axis of the vaginal canal.

415. Operations for Myoma.

HORNUNG (*Zentralbl. f. Gynäk.*, March 12th, 1921) records 447 operations for uterine myoma at the Kiel Frauenklinik. The ages of the patients were: Below 25 years, 1; 25 to 30, 2.6 per cent.; 31 to 35, 6.9 per cent.; 36 to 40, 19.4 per cent.; 41 to 45, 23.8 per cent.; 46 to 50, 31.4 per cent.; 51 to 60, 13.4 per cent.; over 60, 2.5 per cent. Only 115 (25.7 per cent.) were nulliparous. Symptomatic bleeding occurred in 43 per cent. of cases, menorrhagia being twice as common as metrorrhagia. Dysuria or urinary incontinence occurred in 25 per cent.; in about 15 per cent. there were signs of cardiac impairment, consecutive, probably, to the loss of blood. In 9 cases only (2 per cent.) was sarcomatous transformation of the myoma established; cancer of the uterine body coexisted in 5 cases, of the neck in 2. Cases of regressive change in the myomata numbered 11.6 per cent.—necrosis (total or partial) in 20 instances, softening with cyst formation in 17, hyaline degeneration in 7, calcification in 7. In 33 cases only was the myomatous uterus adherent to neighbouring viscera. In 12 cases the myoma was confined to the cervix. The total mortality in this series was 1.79 per cent. The operations employed were: Vaginal extirpation (total), 175, with no death; abdominal extirpation (total), 174, with 7 deaths; supravaginal amputation, 36, with no deaths; abdominal enucleation, 23, with 1 death; conservative vaginal operation, 39, with no death. The adnexa were removed at operation—on both sides in 45 per cent. of cases, on one side in 17.6 per cent. Thrombosis, infarction of the lung, or embolus, followed 1.4 per cent. of 214 vaginal operations, and 4.72 per cent. of 233 abdominal operations. The author concludes that whenever it is possible for removal of myomata not larger than the closed fist, the vaginal route should be selected; in the case of nulliparæ additional space may be gained by using Schuchardt's paravaginal incision. In cases where it is desired to treat conservatively intramural or subserous myomata of the body, Hornung argues, however, that the vaginal approach (as compared with the abdominal) leads to more formidable operative difficulties and to greater danger of infection.

416. Radium Treatment of Haemorrhage at the Climacteric.

EBELER (*Med. Klinik*, 1920, 43 and 44) describes the treatment by radium of 52 cases of "metropathica haemorrhagica" occurring about the menopause. On account of the subsequent occurrence of occasional cases of cervical stenosis with pyometra, intrauterine application was abandoned, and the radium, enveloped by gauze and indiarubber and ensheathed in a silver tube, was placed in the anterior or posterior vaginal fornix, in dosage of 26.5 mg., for eight to twenty-four hours. The applications were made on successive days, or separated by intervals of from two to seven days, and in nearly all cases two series of treatments, between which a single period of menstruation intervened, were found to be sufficient. In 19 of the 52 cases no further menstruation occurred after the completion of the treatment; in 14 cases one period ensued, and in 9 cases two. Of the remaining 10 cases, menstruation became definitely diminished in 7. The author believes that with proper control of the dosage radium treatment of these cases is as useful as x-ray therapy.

417. Management of Labour after Previous Caesarean Section.

In discussing the debatable point of the treatment of a woman in labour who has had a previous Caesarean section VANVERTS (*Gaz. des Praticiens*, March, 1921) quotes six of his own cases, in which two had a normal confinement after previous Caesarean section, and four were treated by repeating Caesarean section. One of the

latter ruptured, and it was necessary to do a hysterectomy. His conclusions are, that a patient who has had a previous Caesarean section should be allowed to go into labour, and if the head engages easily labour may safely be allowed to continue; but if there is any difficulty about the head engaging, a Caesarean section should at once be performed.

PATHOLOGY.

418. Cultivation of the Gonococcus.

SWARTZ, SHOHL, and DAVIES (*Bull. Johns Hopkins Hosp.*, December, 1920), after investigation of various factors affecting the growth of gonococci in culture, state that the essential factor is reduced oxygen tension. Moisture is also necessary for good growth. A reduction in the oxygen tension of 10 per cent. is sufficient to produce optimal growth. The organism will grow luxuriantly, if the oxygen tension is suitable and moisture and uncoagulated protein are present, on media of ordinary reaction range. The technique is very simple. Ordinary broth agar (2 per cent.) is melted, and to it is added half as much sterile ascitic fluid. The tubes are sealed with sterile rubber stoppers, slanted, and kept always in the incubator. They are copiously inoculated, care being taken to prevent cooling, and the inoculated tubes held horizontally, with the agar uppermost, are passed three or four times through the Bunsen flame and quickly corked. This is quite sufficient to lower the oxygen pressure to the requisite degree, when the tubes are returned to the lower incubator temperature. Colonies are visible in from fifteen to eighteen hours, and profuse growth is obtained in twenty-four hours. On this medium the gonococcus is viable for about seven days.

419. Serum Diagnosis of Tuberculosis of Cattle.

HRUSKA and PFENNINGER (*Annales de l'Inst. Pasteur*, January, 1921), using the complement deviation method with Besredka's antigen, and taking the blood direct from the hearts of cattle slaughtered at the abattoir, have been able to bring the serological findings into direct relationship with the *post-mortem* appearances presented by the cattle. Of 304 cattle showing tuberculous lesions, 84.5 per cent. gave a positive fixation reaction. On the other hand, 2.2 per cent. of cattle in which no naked-eye evidence of tuberculosis was found also gave a positive reaction. Going more particularly into the figures, it was found that there was some relation between the extent of the disease and the result of the reaction. Thus, in slight cases a positive reaction was recorded in 60 per cent., with more widespread lesions the reaction was positive in from 84 to 95 per cent., whilst in cases of generalized tuberculosis fully 100 per cent. of positive results were obtained, even though the animals appeared to be in good condition. The authors therefore regard the complement deviation reaction as much more certain than the ophthalmoreaction usually employed in the diagnosis of tuberculosis in cattle. It is interesting to note that the particular antigen employed was prepared from "human" tubercle bacilli, and it gave better results when compared throughout the tests with a similar antigen prepared from bovine strains.

420. Experimental Encephalitis Lethargica.

LEVADITI and HARVIER (*C. R. Soc. Biologie*, February 12th, 1921) have discovered that it is possible to transmit the virus (which is preserved by passage through rabbits) to mice not only by intracerebral injection but, strangely enough, by intraperitoneal and subcutaneous injection, to which rabbits and other animals are refractory. In the case of mice there is an incubation period of two to three days after intracerebral injection and a period of eight days when the injection is made into the peritoneum or under the skin. The authors also record the production of encephalitic keratitis and transmission of the disease by corneal inoculation. An important finding is that the virus remains alive at room temperature for at least sixty days in milk and fifteen days in water. This renders plausible the supposition that water, and especially milk, may play the rôle of vectors of the virus in the propagation of epidemic encephalitis.

421. Primary Tumours of the Vagina.

PICCAGNONI (*Il Policlinico*, Sez. Chir., January 15th, 1921) states that primary tumours of the vagina are rare occurrences. Epitheliomata are uncommon, fibromyomata and pure fibromata and myomata are rarer still, and sarcomata rarest of all. Fibromyoma appears by preference between

the ages of 30 and 40. As a rule, it is isolated and grows in the anterior wall of the vagina. Sometimes, instead of growing in the fibromuscular coat of the vagina, it descends from the uterus or parametrium, to which it may be attached by a pedicle (migratory fibroma). Histologically, it consists of fibrous tissue combined with smooth muscular fibres and numerous thick-walled blood vessels. Fibrous tumours of the vagina, though not essentially malignant, may by their large size give rise to severe dystocia or cause compression of neighbouring organs. At a certain period of their development they may produce haemorrhage or suppuration. Their gravity may also be due to the degenerative changes to which they are liable—namely, telangiectascs, gangrene, and sarcoma. Treatment consists in enucleation of the tumour by isolating it from the vagina. Sarcoma of the vagina differs in its appearance according as it occurs in childhood or adult life. In children it almost always grows in the anterior vaginal wall in the form of a bunch of grapes, and may be latent for a certain time and then give rise to severe haemorrhage. Its growth is extensive *in situ*, but it usually does not give rise to metastases in distant organs. In adults it usually occurs from 30 to 40, grows indifferently in the anterior and posterior vaginal wall, is rounded, usually sessile, and is at first covered by normal mucous membrane. Subsequently it may ulcerate, and give rise to metastases in the lymph glands, peritoneum, and lungs. Histologically vaginal sarcoma consists of spindle cells, and contains numerous blood vessels and interstitial haemorrhages. It is of exceptional gravity, and always recurs after removal. Primary epithelioma of the vagina is most frequent between 50 and 60. It has a predilection for the upper part of the posterior wall. It may appear in a papillary or vegetative form. Sometimes it extends all round the vagina, forming the so-called annular cancer. The symptoms consist of purulent foetid discharge, marked haemorrhage, rectal and vesical disturbance, and neuralgia of the lower limbs when the growth invades the pelvis. The prognosis is grave, and recurrence always occurs after removal. Treatment consists in partial or complete removal of the vagina or in the application of radium.

422. Experimental Exposure of the Pituitary to X Rays.

GELLER (Inaug. Dissert., Breslau, 1920, and *Zentralbl. f. Gynäk.*, March 5th, 1921) describes the results of experimental irradiation of the pituitary in nulliparous rabbits. He noted an apparent checking of growth in the hypophysis, especially in the anterior lobe and the pars intermedia: histologically the small cells were most affected, especially perhaps the young forms of the large chromophile cells. The ovarian cells showed no characteristic alterations in appearance. The rate of growth of the animals appeared to be diminished. Similar treatment of a case of dystrophy adiposo-genitalis was followed by increase of menstruation without alteration in the external habitus.

423. Histological Lesions in a Case of Rabies.

MARCHAND (*Bull. et Mém. Soc. Méd. des Hôp. de Paris*, December 30th, 1920) gives the following description of the histological examination of a man who died of rabies six weeks after being bitten by a dog. The illness lasted four days. The diagnosis was confirmed by inoculation of an emulsion of the patient's medulla into an animal giving a positive result. The autopsy was confined to the brain. No naked-eye lesions were seen. Histologically the cerebrum was intact, the lesions being confined to the medulla oblongata, where they consisted of perivascular inflammation chiefly affecting the vessels of the floor of the fourth ventricle, very slight inflammatory areas in the other bulbar regions, and definite chromatolysis of the cells of the cranial nuclei. There was an absence of Negri bodies.

424. Epithelioma Arising in Lupus Erythematosus.

WANDER (*Arch. of Derm. and Syph.*, January, 1921), in reporting four cases of epithelioma developing on lupus erythematosus, calls attention to the surprising rarity of this occurrence. From the chronicity of lupus erythematosus and the prolonged irritation from treatment, one might expect the resulting continuous trauma to lead to frequent development of carcinoma on such a favourable base. All traumas when sufficiently prolonged are potentially stimuli to cancer formation. In the cases already reported multiple foci of origin are the rule and rapid spread of the disease. In Wander's cases, three of whom were over 60 years of age, the lupus erythematosus had lasted for twelve to twenty-four years when carcinoma developed.

EPITOME OF CURRENT MEDICAL LITERATURE.

MEDICINE.

425. The Epidemiology of Acute Nephritis.

PETRÉN (*Lets Med. i Scandinavia*, January 14th, 1921) notes that though none of his patients had taken part in the war and could not therefore be suffering from trench nephritis, he has found a considerable increase in the number of cases admitted to his hospital with acute nephritis in the past few years. Thus, in the five-year period 1912-1916 inclusive, he saw only 28 cases, whereas in the two-year period 1917-1918 he saw as many as 32. In none of these cases was the nephritis due to scarlet fever, and in the period under review no alterations were made in the rules governing the admission of patients with acute nephritis to hospital. Hence the author's inclination to refer this sudden rise to that vague, unilluminating factor, *genius epidemicus*. He has studied 36 cases seen between 1917 and June 1st, 1919, with a view to classifying them according to the system of Volhard and Fahr, who distinguish two main classes: (1) Acute glomerulo-nephritis with high blood pressure, red cells in the urine, and no oedema; and (2) acute nephrosis with oedema, but without a rise of blood pressure or red cells in the urine. The author found his own cases could not thus be docketed, and he is sceptical as to the value of this classification.

426. Pulmonary Syphilis.

ACCORDING to BERISSO and ADELAIDI (*Rev. Sud-Am. de Endocrin.*, January 15th, 1921), who record twelve cases in patients aged from 38 to 60, preliminary syphilis almost always occurs in the third stage, and rarely in the secondary stage, in which acute symptoms of bronchitis, tracheitis, and laryngo-tracheitis are much commoner. Two main forms of pulmonary syphilis may be described, namely, acute and chronic. In the acute form, which is rare, the patient is suddenly seized with symptoms simulating pneumonia or bronchopneumonia, such as high fever, profuse sweating, cough, and blood-stained expectoration. In such cases the diagnosis is made by bacteriological examination of the sputum. The chronic form is subdivided into (a) a gummatous form resembling tumour of the lung; (b) a form simulating chronic pulmonary tuberculosis; (c) a form with chronic pneumonia which may occur either as caseous pneumonia or as pneumonia with a tendency to fibrosis; (d) a form associated with bronchial dilatation—a very frequent variety; (e) a form characterized by plenisy, usually dry in character; (f) a form accompanied by tracheo-bronchial adenopathy; (g) forms with other visceral lesions—for example, in the liver, stomach, intestine, and spleen; (h) forms complicated by pulmonary gangrene; (i) forms associated with pulmonary tuberculosis, which occurs in a high percentage of cases; (j) asthmatic forms. All the writers' patients, with the exception of one fatal case, were benefited by specific treatment. The best results were obtained in the sclero-gummatous form, and then in the bronchiectatic, pleural, asthmatic, and caseous forms.

427. Renal Decapsulation in Subacute Nephritis.

BOYD, FOWLER, SIMPSON, and FRASER (*Edin. Med. Journ.*, February, 1921) record their experience of the value of renal decapsulation in subacute and chronic nephritis in adults and children. Cases of chronic parenchymatous nephritis appear to benefit by decapsulation more than chronic interstitial cases. By producing diuresis relief may be obtained, but the operation only relieves symptoms and does not abolish the albuminuria. Decapsulation of one kidney appears to afford sufficient relief and is preferable to a double operation at one sitting, it being better to wait for the second operation until the first has been recovered from. The operation should be considered in all bad cases which are not improving after full trial of medical treatment. Catheterization of the ureters proves that the kidney so operated upon functions better than the other. In children, stripping one kidney often relieves all symptoms for a time though the albumin continues, whereas a second operation on the other kidney offers a prospect of cure. In cases of subacute nephritis where the patient is going downhill in spite of all other treatment, decapsulation, by producing diuresis, may cause an improvement in the general condition of the patient, as shown by diminished oedema and a fall in the soluble nitrogen of the blood.

428. Hyperthyroidism.

MORRIS (*Med. Record*, January 22nd, 1921) urges the importance of diagnosing hyperthyroidism before the disease has progressed to the terminal stage. In making an early diagnosis the estimation of the basal metabolism, the adrenaline tests, and the glucose tolerance test are most useful, especially in making a differential diagnosis between hyperthyroidism, early tuberculosis, neurasthenia, D.A.H., etc. In hyperthyroidism the metabolic rate is always increased in direct proportion to the amount of thyroid intoxication. The hypodermic injection of 8 minims of a 1 in 1,000 solution of adrenaline increases both pulse rate and blood pressure, followed by a fall and then a secondary rise, with a return to normal in about an hour and a half, and such injection causes an exaggeration of symptoms. These cases have a low glucose tolerance, a hyperglycaemia following the ingestion of 100 grams of glucose, even in borderland cases. X rays or radium in conjunction with medical treatment give excellent results, the use of surgery being mainly when other measures fail, and when pressure symptoms or malignant degeneration of the thyroid occur, or in removing causes of hypersecretion.

429. Radiotherapy of the Endocrine Glands.

ACCORDING to BÉLÈRE (*Par. méd.*, February 5th, 1921) there are at present only three glands of internal secretion—namely, the thyroid, thymus, and hypophysis—that are suitable for radiotherapy. As regards the thyroid, radiotherapy is the best treatment for Graves's disease and more generally for all forms of hyperthyroidism. Enlargement of the thymus giving rise to permanent or paroxysmal dyspnoea, cyanosis, and syncopal attacks, is better treated by this method than by thymectomy. As regards the hypophysis, hypopituitarism, which is manifested by Fröhlich's adiposo-genital syndrome, requires pituitary opotherapy, whereas hyperpituitarism and pituitary tumours, in the absence of syphilis, is an indication for radiotherapy. Treatment of arterial hypertension by radiotherapy of the suprarenals, as suggested by Zimmer and Cottenot, does not appear to justify the employment of the method in practice. No radiotherapeutical investigations have hitherto been made on the pineal gland.

430. A Sign of Cerebro-spinal Meningitis.

EDELMANN (*Wien. klin. Woch.*, November 25th, 1920) describes the following sign which he has observed at an early stage of cerebro-spinal meningitis. On flexing the leg at the hip-joint with the knee extended, as in eliciting Lasègue's sign, dorsal flexion of the great toe frequently occurs, as in Babinski's sign. The sign is met with in senile cerebro-spinal meningitis, in which nuchal rigidity and Kernig's sign are sometimes absent. It is also present in cases of cerebral oedema.

431. Epidemic Hiccough.

HOPFST (*Nederl. Tijdschr. v. Geneesk.*, February 12th, 1921) emphasizes the fact that none of the patients with this condition feel ill but are able to carry on their daily occupation. As regards treatment, he does not think that vertical pressure on the cricoid, which has been recommended, is of any use, but he advises pressure over the supraclavicular fossa, where one is more likely to reach the phrenic nerve. He has had considerable success from the use of a combination of the bromides in the form of Charcot's solution, a teaspoonful of which is given every two hours until the hiccough ceases. McWalter, who reported a small outbreak of hiccough in Dublin, found intranasal applications of chloroform, camphor, and olive oil of much service.

432. Myeloid Leukaemia Treated with Benzol.

SIRÉNON (*Le Scalpel*, January 15th, 1921) reports a case of myeloid leukaemia successfully treated with benzol. The woman, aged 37, had been ill about two years and presented typical signs of the disease, with an enormous spleen and 200,000 leucocytes and 3,000,000 red blood corpuscles. She had been treated for a year with arsenic, splenic opotherapy, and for six months with X rays, but without any benefit. On February 1st, 1918, benzol was given, and eight weeks later there were only 15,000

leucocytes and the red corpuscles had gone up to 4,000,000, with great improvement in general health. Benzol was administered for three months altogether, and in that time 354 grams were given in all. As the patient left the country at this time, the further development of the case was unknown, but as far as it went it seemed conclusively favourable. The author has collected nineteen cases treated with benzol, and all showed definite improvement. Abnormal or pathological white cells seem to be destroyed by benzol and abnormal increase of leucocytes checked. In the leucolytic process auto-leucolysis are generated which tend to keep down the number of leucocytes. The myelocytes are peculiarly sensitive to the action of benzol.

433. Insomnia as a Sequel of Lethargic Encephalitis.

ROASENDA (*Il Policlinico*, Sez. Prat., February 7th, 1921) records 3 cases in patients aged 35, 36, and 5 respectively, who, after an attack of lethargic encephalitis, presented an inversion of the natural rhythm of sleep. Instead of sleeping during the night and remaining awake during the day they enjoyed a fairly good and refreshing sleep from early morning until late in the day, but were tormented by insomnia with psycho-motor agitation during the night. The insomnia was not affected by any of the usual remedies, but persisted indefinitely.

434. Reed Dermatitis.

TIMPANO (*Il Policlinico*, Sez. Prat., January 3rd, 1921) states that this condition, which is met with among reed workers, usually affects the forehead, eyelids, cheeks, nose, antero-lateral parts of the neck, back of the hand, and scrotum. The skin is swollen and reddened without a distinct edge; occasionally vesicles are found containing a fluid with a few red corpuscles. The patient complains of smarting and itching. Usually there is no general disturbance, but occasionally there is a rise of temperature of varying intensity, and sometimes albuminuria. The conjunctiva is often affected, and presents hyperaemia, photophobia and lachrymation. The nasal mucous membrane may also be involved, when there is itching, smarting, and in severe cases frontal headache. The prognosis is favourable. Treatment consists in rest, soothing ointments, such as oxide of zinc, salicylic acid, ichthyol, etc. The dermatitis clears up in a few days without leaving any trace. Clinical observation and laboratory experiments carried out by Timpano have shown that reed dermatitis is due to the chemical action of the black powder contained in the leaves of old reeds, the powder acquiring pathogenic properties owing to special changes which it undergoes in course of time and as the result of damp.

SURGERY.

435. Removal of Suprarenal Capsules for Epilepsy.

FISCHER has shown by his animal experiments that the removal of the suprarenal capsule diminishes susceptibility to convulsions and reduces muscle tonus. Fischer believes that the central nervous system plays only a subsidiary role in epilepsy, the vegetative nervous system and the organs of internal secretion being of prime importance. This would explain the ill success which has attended operations on the brain for the cure of epilepsy. BRUENING (*Zentralbl. f. Chir.*, October, 1920), with Fischer's work in his mind, has applied the principles to man and has excised the left suprarenal capsule from nine patients suffering from epilepsy. He describes the technique in some detail. The organ is approached by the abdominal route. The left adrenal is that chosen because, although the right lies lower, there is danger of wounding the hilary passages or tearing the liver. Bruening makes for the lower border of the pancreatic tail after pulling the colon well down and perhaps mobilizing the splenic flexure. The kidney is depressed and the fatty capsule dissected from the suprarenal, which is removed after picking up its vessels. Drainage is only instituted if haemostasis has not been satisfactory. All the patients recovered. The dissection is a deep one, and long instruments are necessary. In two cases, where fits were a daily occurrence, there have been no further convulsions. In all the others there was improvement, sometimes a very great improvement. Bruening is encouraged by this method of treatment. The cases were unselected, and one at least (an old encephalitis) was unsuitable for operation. He believes that the best time for interference is after puberty, when growth is finally slowing down. His two successes were in patients aged respectively 18 and 21 years. He

admits that this question of the influence of the sympathetic system on the brain is in its infancy, and contemplates the necessity for removal of the right suprarenal as well. Accessory adrenals and compensatory hypertrophy of the remaining adrenal tissue are possible causes of failure which require investigation.

436. The Treatment of Tuberculous Empyema.

SAUGMAN (*Hospitalstidende*, January 19th, 1921) notes that only a few years ago tuberculous empyema was usually treated like other forms of empyema by incision, costal resection, drainage, and aspiration of the pus through a drain. Although of late fashion has swung in favour of conservative treatment, the practice is still all too common of draining a tuberculous empyema—a practice which the author stamps as a malpractice. Not only does he recommend conservative treatment with simple gas replacement after aspiration in pure tuberculous empyema, but also in many cases of mixed infection. He has found it possible to aspirate even several litres of pus at one sitting, and to replace it by a slightly smaller quantity of air without the slightest inconvenience to the patient, who was, indeed, much relieved thereby. This replacement can be repeated as often as the operator likes, and in cases of mixed infection can, if necessary, be supplemented by irrigation of the pleural cavity with saline or antiseptic solutions. Even in the most septic mixed infections this comparatively conservative treatment should be given a fair trial before the surgeon resorts to incision and free drainage.

437. Pain on the Left Side in Appendicitis.

ACCORDING to HAMANT (*Rev. méd. de l'Est*, January 1st, 1921), who records an illustrative case in a girl aged 13, pain on the left side in appendicitis may be primary or secondary. When it is primary, it is due to the appendix being situated on the left side. The organ may be so displaced under three different conditions: (1) Inversion of all the organs; (2) the caecum and appendix, as the result of ptosis or through their possessing a long mesentery, take up their position on the left side of the abdomen; (3) the appendix being abnormally long becomes attached to the left iliac fossa or its immediate neighbourhood. Much more frequently the pain on the left side in appendicitis is only secondary, and is due to an extension of an inflammation or suppuration originating on the right side.

438. Gunshot Wounds of the Mastoid.

LANNOIS and SARGNON (*Ann. des mal. de l'oreille*, Nos. 10-12, 1914-1915), who record 38 illustrative cases, state that fractures of the mastoid, which were relatively rare in previous wars, were more frequent in 1914 owing to the nature of trench warfare, in which wounds of the skull, face, eyes, and ears were much commoner than before, as the result of use of bombs. The prognosis of operation in simple cases is very good and the mortality nil, healing taking place by first intention. The complicated cases may be divided into six classes according to the following complications: (1) Lesions of the pinna and external auditory meatus; (2) suppurative otitis media; (3) mastoiditis; (4) complete peripheral facial paralysis; (5) deafness; (6) neighbouring lesions (skull, face, eyes, large vessels).

439. Acoustic Nerve Tumours.

DE MARTEL (*Bull. Mém. Soc. de Chir. de Paris*, November, 1920) describes his present-day technique when operating upon tumours of the acoustic nerve. He remarks that the results of operations upon these cases have been so bad that the physician who sees the cases is chary of handing them on to the surgeon. He has recently had three successes out of five attempts, and claims that these are the first cases of recovery after operation published in France. De Martel uses Cushing's technique with two variations. He has the patient in the sitting posture astride a chair, with his forehead resting on the arm, and infiltrates with novocain instead of giving a general anaesthetic. He thinks that these two points are of great value, as haemorrhage is less and the patient is able to aid the surgeon by moving the head when required and rendering the pontine angle more accessible. These tumours are usually small, occupy the cerebello-pontine angle, and early produce deafness.

440. Foreign Body in the Heart.

ROCCAPELLA (*Riv. Osped.*, December 31st, 1920) records the case of a soldier wounded in 1918 by a bullet in the precordium. When seen in 1920 the radiogram showed the presence of a foreign body in the wall of the right ventricle. The patient showed symptoms of limited soft pericardial adhesions, and presented disturbances of the

rhythm of the heart with pulsus alternans and respiratory disturbances. Wounds of the heart may be grouped into (1) cases where the projectile can be removed at once; (2) cases where the projectile has shifted from its first position in the heart, along the vessels, or vice versa, from the vessels to the heart cavities; (3) cases where a projectile remains in the heart without causing any serious trouble; (4) rare cases where the wound or the retention of the foreign body is followed by functional disturbances of the valvular orifices, of the cardiac rhythm, or auriculo-ventricular conduction. The case recorded by the author belongs to the fourth of these groups.

441. Carcinoma of the Duodenum.

CARCINOMA of the duodenum is one of these rare diseases—probably of commensurate occurrence than is generally believed—which one meets with from time to time. McGUIRE and CORNISH (*Ann. Surg.*, November, 1920) saw two cases within a few days of one another. The pre-operative diagnosis is usually wrong, practitioner and surgeon alike mistaking the disease for pyloric carcinoma. If the proximal duodenum is affected, such an error is almost unavoidable. Many cases of cancer of the ampulla of Vater or of the terminal bile and pancreatic ducts are wrongly described as being duodenal carcinoma. In these the duodenal involvement is secondary. Jaundice is a prominent sign in these cases. McGuire and Cornish publish two examples of this condition to contrast with true duodenal carcinoma.

442. Laryngeal Hemiplegia due to Gunshot Wounds.

COLLET (*Ann. des mal. de l'oreille*, Nos. 10-12, 1914-1915) records 12 cases of this condition, 8 of which were situated on the left side. Of the 4 cases in which the hemiplegia could be attributed to a lesion of the recurrent laryngeal nerve, in 2 there was pure laryngeal hemiplegia, and in 2 laryngeal hemiplegia was associated with paralysis of the brachial plexus. In 3 cases in which the hemiplegia appeared to be due to a lesion of the spinal accessory it was accompanied by other paralytic phenomena, indicating a lesion of neighbouring nerve trunks—namely, lingual hemiplegia in 2 cases, lingual, pharyngeal, and scapular hemiplegia in 1 case, and lingual and pharyngeal hemiplegia in 1 case, accompanied by acceleration of the pulse. In one case there was disturbance of taste due to a lesion of the glosso-pharyngeal nerve. Laryngoscopic examination showed the paralysed vocal cord in the cadaveric position in 4 cases, in 3 of which there was paralysis of the recurrent laryngeal and in 1 of the spinal accessory. In the other cases the vocal cord assumed the median position, but it was not always rectilinear. In 4 cases, which were those with the vocal cord in the cadaveric position, the aphonia was immediate and complete; in one case it was immediate but subsequently improved; in the other cases the vocal impairment, which was also immediate, was not aphonia but hoarseness only, and in one case the aphonia did not develop until some days after the wound. The most important symptom was the intense dysphagia due to paralysis of the vagus and even of the glosso-pharyngeal. As a general rule the prognosis was unfavourable as regards recovery of function.

OBSTETRICS AND GYNAECOLOGY.

443. The Use of Pessaries.

KELLY and FRICKE (*Therapeutic Gazette*, January, 1921), after a summary of the history of the pessary, review its modest place in the gynaecological practice of to-day. They suggest that a pessary is not at all used as formerly, as a mechanical device to correct a displacement; but that its function is simply to take up a certain amount of slack in the vagina and to prevent further downward displacement, to keep the uterus from sagging down on to the pelvic floor, and in this way to relieve the dragging sensation. It is likely to be useful, therefore, in retroflexions with descensus, and for certain cases of prolapse, but not in the antelexions so much pessary-treated by a former generation. The important factor, they consider, is not flexion but descensus, and the vital question, whether or not a pessary is likely to help the patient, hangs on an examination which determines whether or not she has any decided descensus, and this is best revealed by examining in a standing posture. The most useful and best form of pessary, they consider, is the simple ring made of thick rubber—thin ones should be rejected—large enough to stretch the vaginal walls and take up slack, but not to make a tight fit. Soft

rubber and air inflated pessaries, much in vogue still, ought to be discarded, as they provoke irritating secretions, and are a source of infection. The Gehring pessary is a most serviceable form, they consider, in the group of cases in which the anterior wall of the vagina pouts out. When inserted, it simply rolls over in the vagina and does not tend to escape; it is worn with the cervix resting between the two limbs of its double U. ILL (*Amer. Journ. of Obstet. and Gyn.*, January, 1921) describes the Gehring pessary and its method of introduction in some detail. He considers it of great value in certain cases, but states that patients find it impossible, and many doctors—unaccustomed to its form—find it difficult, to replace the instrument after removal.

444. Caesarean Section in Infected Cases.

BROUHA (*Gyn. et Obstet.*, 1920, vol. ii, No. 6) discusses the question of whether the operation of Caesarean section should be confined to uninfected cases. From 1914 to 1918, he states, he performed 60 Caesarean sections, and of these cases 12 were uninfected, but the other 48 had been repeatedly examined at their homes before operation, and of these two-thirds had membranes ruptured for periods varying from two hours to five days. His results comprised a mortality of two cases (3.3 per cent.), but both of these cases were uninfected before operation. One of the fatal cases had undergone two Caesarean sections previously, and death was presumably due to shock, following rather severe haemorrhage. The other death was from septicaemia, which the author suggests may have been due to imperfect sterilization at the operation. All of the 48 cases which were more or less infected before operation made excellent recoveries.

445. Alimentary Amenorrhoea.

KURTZ (*Zentralbl. f. Gynäk.*, February 26th, 1921) uses this term in preference to the more familiar one of "war amenorrhoea" in a paper based on observations made at the Berlin Institute for Epileptics. Of 142 women who were interned in this institute throughout the war only 13, or 9.2 per cent. of those aged from 16 to 44, with previously normal menstruation continued to menstruate the whole time. In the remaining 129, or 90.8 per cent., amenorrhoea set in, the onset being most frequent in the fourth quarter of 1916 and first quarter of 1917. There was at the same time a loss of weight amounting on the average to one-eighth of the initial weight. In 40.8 per cent. menstruation reappeared by March, 1920, and in the rest it remained in abeyance. The longest duration of amenorrhoea in cases which had recovered was forty-seven months, the average time being two years, and the longest duration of persistent amenorrhoea was sixty-one months, the average time being three years and two months. None of the causal factors of amenorrhoea mentioned in the literature were present, such as psychological trauma, overwork, and sexual abstinence; but disturbance of nutrition caused by the blockade was alone responsible. In 32 per cent. diminution in the size of the uterus could be detected by palpation. In one case which came to autopsy nothing could be found in the uterine mucous membrane except glandular deficiency. The prognosis did not appear to be so bad as was often stated in the literature. It was most favourable in women between the ages of 26 and 33.

446. A Study of Chronic Endocervicitis.

MATHEWS draws attention (*Surgery, Gynaecology, and Obstetrics*, March, 1921) to the frequency of this condition, and describes in detail the pathology. He makes an interesting suggestion as to the cause of backache associated with this disease—namely, that there is a cellulitis around the utero-sacral ligaments. He considers that the best treatment is undoubtedly the operative, and describes in detail the method of excising a cone of cervical tissue containing the cervical mucous membrane. No complications in pregnancy or labour have been observed to follow this operation.

447. Turpentine Injections for Gynaecological Infections.

FRIEDERICH (*Zentralbl. f. Gynäk.*, March 12th, 1921) summarizes the results, reported from various sources, of the treatment of gonorrhoeal and non-gonorrhoeal inflammations of the urogenital tract, especially in females, by intramuscular injections of turpentine (Klingmüller) or its derivatives (Kleemann, Karo). From his personal experience of this treatment in 22 cases, Friederich concludes that it is more successful in chronic than in sub-acute or acute inflammatory conditions of the adnexa.

In 9 out of 14 of his chronic cases the subjective symptoms had completely, and the objective symptoms almost completely, disappeared after from one to five injections made at intervals of five days; in one case a painful adnexal tumour, the size of an apple, had completely disappeared five days after a single injection. In three cases acute inflammatory exacerbations appeared so to respond to turpentine injections as to become quiescent and permit of an accurate diagnosis of hitherto obscure adnexal abnormalities, which were then successfully treated by operation. The injections were made close to the bone, three fingerbreadths below the iliac crest in the posterior axillary line. Other writers have recommended injections into the gluteal muscles.

PATHOLOGY.

448. Development of Bone.

TILLIER (*Lyon Chir.*, July-August, 1920) draws attention to a line of denser bone, parallel to the epiphyseal cartilage, and situated in the juxta epiphyseal region, frequently to be seen in radiographs of the long bones of children. This line is a perfectly normal characteristic of young bone, and Tillier has conducted a considerable investigation into its meaning. The line is very narrow, traverses the whole thickness of the bone from side to side, and in the author's opinion constitutes a fine band of condensation at the boundary of metaphysis and diaphysis. The metaphysis is that part of the bone which lies between the primitive diaphysis and the epiphysis, and probably originates in the deposition of bone on the proximal side of the epiphysis. Tillier notes that the block of cartilage at the end of the foetal bone is in proportion considerably larger than the subsequent epiphysis will be. The effect of ablation of the juxta-epiphyseal bone (metaphysis) causes a definite decrease of growth, not so great as removal of the epiphysis, but much more pronounced than removal of any part of the diaphysis proper. Tillier pleads for the individuality of the metaphysis and reproduces several drawings from x-ray plates to illustrate the special pathology of this region. In rickets, for instance, a series of these lines can often be seen between the epiphyseal cartilage and the extremity of the diaphysis, as if bone had been laid down in the metaphysis in successive layers. In tuberculosis also the shaft seems to be sometimes sealed off by this film of dense bone, the disease involving metaphysis and epiphysis only. The fracture of both bones of the forearm in children occurs at the site of this condensed line, not because the bone is weak there, but because the bony homogeneity is interrupted at that point, and perhaps its elasticity is there impaired.

449. The Sachs-Georgi Reaction in Syphilis.

ARIAZZI and PICO (*Rev. de l'Inst. Bact.*, December, 1920) made a comparative study of the Sachs-Georgi and Wassermann reactions in 240 cases, consisting of 30 cases of tuberculosis, 65 of leprosy, 11 of cancer, 55 of syphilis, and 79 of various other conditions, with the following results: In 390 out of 408 specimens examined, or in 95.43 per cent., the Sachs-Georgi reaction was the same as the Wassermann reaction. In the divergent cases 13 gave a negative Wassermann reaction and a positive Sachs-Georgi reaction. In 4 of these there was no history, 6 were found to have syphilis, and in 3 a positive Wassermann reaction was subsequently obtained by reactivation. In 8 cases the Wassermann reaction was positive and the Sachs-Georgi reaction negative; 2 of these were cases of leprosy, 2 of syphilis, 1 of malaria, and in the rest no data were available. The writers conclude that the Sachs-Georgi reaction is a valuable addition to the sero-diagnosis of syphilis, and should be used as a complementary reaction to the Wassermann reaction. MURSTAD (*Medicinsk Revue*, February, 1921) has compared Sachs-Georgi's reaction with Wassermann's in a series of 314 cases, the serums of which were sent to Gade's Institute in Bergen. The results were identical in 284 cases—that is, in 90 per cent. An investigation of the 13 cases in which the Sachs-Georgi reaction was negative and the Wassermann positive showed that in 8 there was a definite history of syphilis. In the remaining 5 cases there was no available evidence of syphilis apart from the positive Wassermann reaction. Somewhat similar observations were made in the 17 cases in which the Sachs-Georgi reaction was positive and the Wassermann negative; in 9 there was, and in 8 there was not, a history of syphilis. In 6 cases in which specific treatment had been instituted

Sachs-Georgi's reaction was negative, while Wassermann's was still positive: in 8 other cases that had been given specific treatment Sachs-Georgi's was still positive, while Wassermann's was negative. It would seem from these figures that, as a guide to treatment, the value of these two reactions is approximately equal. In 4 cases of lepra tuberosa both reactions were positive, and in one case of lepra anaesthetica both reactions were negative. In a few cases of ulcus molle, miliary tuberculosis, pneumonia, and acute rheumatism, the Sachs-Georgi reaction was positive in the absence of any other evidence of syphilis.

450. Bilateral Testicular Sarcoma.

ACCORDING TO KAISER (*Wien. Klin. Woch.*, December 2nd, 1920), who records an illustrative case, very few examples of bilateral testicular tumour have been recorded. Kocher, in his work on diseases of the male sexual organs, has collected 15 cases in which sarcoma appeared simultaneously in both testes. The metastases usually first involve the retroperitoneal glands and internal organs, such as the liver, spleen, and lungs. Frequently, however, metastases occur by the blood stream, as in sarcoma generally, and tumours appear in the skin and bones. Two factors have been invoked in the etiology of malignant disease of the testes—namely: (1) The tendency of retained or incompletely descended testes to malignant degeneration; and (2) trauma. Neither of these factors, however, could be invoked in Kaiser's case. His patient was a man, aged 54, the father of six healthy children, in whom bilateral enlargement of the normally situated testes occurred without any previous injury. The diagnosis of small round-celled sarcoma having been established by biopsy, both testes were excised. Five months later a recurrence took place in the serotum, and a metastasis appeared on the skull, but both disappeared under x-ray treatment.

451. Xanthoma Multiplex.

GAMRAT (*Ann. de Derm. et de Syph.*, November, 1920) gives an account of the microscopic appearances of these interesting lesions. In the nodules there is a mass deposit of lipid substances, amongst which cholesterol predominates. This deposition of cholesterol is definitely limited to the xanthoma nodule, of which it occupies the outer two-thirds; the centre is much less rich in this substance, and here the fibrous tissue is more developed. The infiltration is mainly cellular, the polyhedral and fusiform cells being completely studded with granules, or rather anisotropic droplets. At no part may signs of cellular degeneration be found, so that the presence of the cholesterol is more probably due to a process of infiltration from without than to any degenerative alteration of the cells. An abundant fibrous tissue reaction may be seen in the neighbourhood of the xanthoma cells. A peculiar feature found by Gamrat in all the sections examined was the presence around the capillaries, both within and outside the nodule, of mantles of lipid granules infiltrating their walls. This points to the fact that the cholesterol comes from the blood, which generally, if not always, shows an increased amount of this substance. The granules having traversed the capillary walls may act as foreign bodies and produce a reaction process. Their presence in the cells may be the result of phagocytosis or of absorption by osmosis. The xanthoma cells will then correspond to the so-called "acrophages" which absorb the uric acid crystals in gouty tophi.

452. The Staining of Phagocytes.

CROSS (*Johns Hopkins Hosp. Bull.*, February, 1921) gives a simple method for the clear and sharp staining of phagocytes which would seem to be desirable. To 100 c.c.m. of neutral distilled water there are added 20 c.c.m. each of glycerin and alcohol and then 2 c.c.m. of phenol. In this fluid there is dissolved, by shaking for two or three minutes, crystal violet 0.06 gram and pyronin 0.2 gram. The stain is ready for use without filtration, and keeps for a long time if shielded from direct sunlight and the bottle is well stoppered. Smears are made on carefully cleaned glass slides and merely dried in the air. The stain is flooded on for five to ten seconds, and thoroughly washed off with distilled water, but direct drying of the preparation by blotting paper is avoided. The nuclei are stained violet and the cytoplasm takes a delicate lavender tint with the cell limits clearly and sharply defined, so that it is easy to distinguish between intracellular and extracellular bacteria, which are coloured deep purple. The chief advantage claimed for the method is that there is a total absence of annoying precipitates which are too often associated with the staining of phagocytes.

EPITOME OF CURRENT MEDICAL LITERATURE.

MEDICINE.

453. Haemolytic Jaundice.

LORENZINI (*Il Morgagni*, January 31st, 1920) published a case of this disease in a child aged 12, and took the opportunity of discussing the subject at some length. Historically little was written about it before 1900, when Minkowski described a case. There are two main groups—acquired secondary haemolytic jaundice and primary. The first group depends on infective agents (for example, pneumonia), parasites (malaria), poisons (chloroform), or physical causes—for example, cold. The second group includes the so-called congenital haemolytic jaundice, which may be of two types (Minkowski-Chauffard or Hayem-Widal). The chief symptoms of primary haemolytic jaundice are: (1) Jaundice, but this is not as constant as was at one time believed. (2) The faeces are always well coloured and rich in bilin. (3) Acholuria is almost always present. (4) Splenomegaly rarely is absent. (5) Enlargement of the liver is usually present but slight. (6) Anaemia of haemolytic type is an important symptom; the leucocytic formula is usually normal; the granular blood cells derived from the bone medulla may be present, but are not of such diagnostic importance as was at first believed. The globular fragility under hypotonic salt solution is an important differential sign. Authorities are not agreed as to the etiology and pathogenesis, although the favourable results that have followed splenectomy seem to implicate that organ. Some relation probably exists between haemolytic jaundice, Hanot's cirrhosis, and Banti's disease, and the author discusses this rather fully. The differential diagnosis is chiefly concerned with chronic catarrhal jaundice, Hanot's cirrhosis, paroxysmal haemoglobinuria, familial jaundice, and pernicious anaemia; and perhaps the most important differentiating sign that distinguishes haemolytic jaundice is the globular fragility in the presence of hypotonic salt solutions. The prognosis, as far as the primary congenital forms are concerned, is good. The only treatment that seems useful is splenectomy; for example, Calnet reported 47 cures in 54 operated upon.

454. Tincture and Infusion of Digitalis in Therapeutics.

TINCTURE of digitalis was prepared by WEISS and HATHER (*Journ. Amer. Med. Assoc.*, February 19th, 1921), the marc of which was dried and used in the preparation of an infusion; this infusion of marc was tested on cats, and found to be inert, showing that all of the active water-soluble principles of the leaf are extracted during the percolation for making the tincture. This method of testing the marc affords a delicate means of finding the degree to which the active water-soluble principles are extracted during the percolation of the drug. There is no essential difference in the amounts of the saponin bodies present in the tincture and in the infusion prepared from equal weights of the leaf, and therapeutic doses of digitalis do not contain enough to induce any undesired effects. Infusions of digitalis were prepared in different ways. In each case the marc was washed and dried, after which it was used for the preparation of tincture, and this tincture was tested on cats in order to determine to what extent the active principles had been extracted during the preparation of the infusion. The official infusion does not represent the drug completely; hence the standardization of the leaf does not ensure uniformity in activity of the infusion. The variability of the infusion is at the expense of the more absorbable of the active principles. The infusion prepared according to the method described represents the activities of the leaf completely; hence it permits of uniformity when a standardized powder is used for making it. It may be used in place of the tincture in doses just ten times the volume of those of the latter, and it becomes a matter of indifference, so far as therapeutic effects are concerned, which is used. The authors have been unable to discover any experimental evidence to support the view, still held by many, that there is a necessary qualitative difference between the actions of the tincture and those of the infusion of digitalis, even when the latter is prepared properly. An infusion of digitalis prepared in the manner recommended, and kept in completely filled and hermetically sealed bottles for more than two years and five months, retained its activity unimpaired, as shown by the results of tests on cats and by the therapeutic effects on man.

455. Intestinal Tuberculosis and the Anaemia of Consumptives.

HIS investigations in the tuberculosis wards of the Öresunds Hospital have led KRAG-MÖLLER (*Acta Medica Scandinavica*, January 14th, 1921) to correlate the anaemia of pulmonary tuberculosis with tuberculous disease of the small intestine. His first series of cases, establishing this correlation, were obtained from hospital records. His second series of cases were personally investigated, and his material was not "selected" in any other way than that he concentrated on cases likely to be soon available for *post-mortem* examination. About 130 patients were examined, 49 of whom were also examined *post-mortem*. Monthly examinations of the blood were undertaken with Autenrieth-Königsberger's apparatus for determining the percentage of haemoglobin. As the author's table shows, the consumptives who suffered from tuberculosis of the small intestine were much more anaemic than those who escaped intestinal tuberculosis, or whose intestinal tuberculosis was confined to the large intestine. It was also noted that the higher the position of tuberculous ulceration in the small intestine the more severe was the anaemia. In the two worst cases of anaemia (40 per cent. and 46 per cent. haemoglobin) the jejunum was involved. The author suggests that the anaemia of intestinal tuberculosis is not due to haemorrhage from the bowel but to absorption of haemolytic toxins. This explanation would account for the fact that patients with tuberculosis of the large intestine are less anaemic than those with tuberculosis of the small intestine, because the former condition provokes diarrhoea which prevents the absorption of toxins. This diarrhoea also helps to conceal the anaemia by making the blood more concentrated.

456. The Relation of Lethargic Encephalitis to Influenza.

ALMASIO (*Il Policlinico*, Sez. Prat., February 14th, 1921) states that there was an epidemic of 158 cases of lethargic encephalitis at Turin between December, 1919, and April, 1920; 4 occurred in the second half of December, 74 in January, 43 in February, and 17 in March; 48 died—a mortality of 34 per cent. The death rate was highest after 60 (6 deaths among 11 cases), fairly high from 20 to 30 (18 deaths among 47 cases) and from 30 to 40 (7 deaths among 31 cases), and lower from 10 to 20 (4 deaths among 19 cases). The mortality in children under 10 was fairly high (3 deaths among 9 cases). The lowest mortality was from 50 to 60 (1 death among 6 cases). The two sexes were almost equally affected, 74 of the cases being in males and 64 in females; 72 had not had influenza in 1918, and only 12 had been attacked then. In 38 the disease started suddenly, and in 14 the symptoms of encephalitis appeared as a complication or sequel of influenza. All social classes were affected. No example of contagion was observed. The influenza epidemic of 1920 in Turin closely corresponded with the epidemic of lethargic encephalitis. It gradually increased in intensity from the beginning of January till the 29th, progressively diminished in February, and completely ceased at the end of March. In both influenza and lethargic encephalitis the majority of cases occurred in persons between 20 and 30 years of age. The curves of the two diseases, however, differed as regards the number of those affected in early life. Whereas in encephalitis there were very few patients between the first and fifth years of life, in influenza there were many cases at this age.

457. Congenital Syphilis in the Second Generation.

SIDLER-HUEGELIN (*Schweiz. J. med. Wochs.*, January 20th, 1921) throws light on the fate of syphilis in the second generation by a study of the progeny of the subjects of congenital syphilis. He found that of 250 such persons, 50 had married. Of these marriages 14 were sterile, and the remaining 36 marriages were followed by the birth of only 65 children. As an earlier investigation by the author showed, 48.7 per cent. of the subjects of congenital syphilis die in childhood, and those who survive childhood often succumb later to their syphilis, to rickets, or to tuberculosis, to which they are markedly predisposed. But though the subjects of congenital syphilis seldom marry, and if they do so, seldom breed many children, neither these children nor the persons whom the subjects of congenital syphilis marry develop syphilis itself. In spite of careful clinical, radiological, and serological examinations of all but 5 of

the 65 children born to the subjects of congenital syphilis, the author could find syphilis in one case only. Even this case he is doubtful about. Wassermann examinations of 12 women who had married the subjects of congenital syphilis proved negative in every case. Yet, if transmission of the disease were feasible under these conditions, its existence in the wife ought to be demonstrable by Wassermann's test. The author is accordingly very dubious as to the possibility of congenital syphilis being transmitted from husband to wife, or from parent to child. He ends his paper, however, with the advice that, when a woman suffers from congenital syphilis, her blood should be tested before marriage, and if Wassermann's reaction proves positive she should undergo a thorough combined course of specific treatment. Even if this does not convert a positive to a negative Wassermann reaction—and the chances of this conversion are small—it is yet probable that this treatment would have a beneficial effect.

458. Vaccination in Country Districts.

GIOSEFFI (*Il Policlinico, Sez. Prat.*, January 10th, 1921) states that the year 1919 was bound to produce an outbreak of small-pox owing to the return of prisoners of war from enemy centres infected with the disease. In the towns where prompt precautionary measures, such as isolation, disinfection, and vaccination on a large scale had been carried out, the population was mostly refractory to small-pox, especially as it was the practice to vaccinate the children during the school period and adults on admission to public appointments, and in seacoast towns before embarkation. Country districts, on the other hand, were not so protected, owing to the tendency of the ignorant country folk to escape vaccination as far as possible. Gioseffi suggests that presentation of a certificate of revaccination should be made compulsory before marriage and admission to religious services, and that general vaccination or revaccination should be carried out every spring.

459. Herpes of the Anal Region with Meningeal Symptoms.

RÉNON and BLAMOUTIER (*Soc. Méd. des Hôpitaux*, February 3rd, 1921) report the case of a woman, aged 35, who was admitted into hospital on October 5th with a history of four days' intense and increasing headache, photophobia, stiff neck, typical Kernig sign, and vomiting. Lumbar puncture showed raised tension, nothing abnormal cytologically. Next day the meningeal symptoms were much better, but around the margin of the anus there was a definite eruption of herpes. A second lumbar puncture showed normal fluid tension, a few lymphocytes, and some staphylococci. In the herpetic area there was absolute anaesthesia. The patient left the hospital convalescent on October 26th. When seen again, in January, she complained of headache, especially after fatigue—a lumbar puncture gave a fluid nearly normal.

460. Pulmonary Influenza in Children.

BOSSERT and LEICHTENTRITT (*Deut. med. Woch.*, February 10th, 1921) are convinced that, since the recent epidemics of influenza, many cases of chronic pulmonary disease in children can be traced to infection with Pfeiffer's bacillus. They describe four different types of influenzal disease of the lungs. The first is characterized by a fairly chronic course, but complete recovery follows after a period of weeks or months, during which there seems to be little or no change in the physical signs. In the second type the disease runs a more intermittent course, and the physical signs do not persist with the same severity throughout the child's illness. In the third type there is no change in the physical signs over a period of years, and in the fourth type the disease terminates fatally with bronchopneumonia. The authors give details of several illustrative cases, and stress the points of significance in the differential diagnosis of influenza and tuberculosis. In young children a negative von Pirquet reaction is instructive; the presence of Pfeiffer's bacillus in, and the absence of the tubercle bacillus from, the sputum are also indicative of influenza. A sign which the authors found to be common in these cases of chronic influenzal bronchiectasis was a machine-gun-like rale heard behind the lower lobes. In one of the cases described the adventitious pulmonary sounds cleared up under treatment with potassium iodide. The authors conclude that post-influenzal bronchiectasis and other chronic pulmonary changes are remarkably common as a sequel to influenza in childhood, and they insist on the importance of sifting out such cases from those which are due to the tubercle bacillus, for the exclusion of pulmonary tuberculosis saves the patient from the stigma and costly treatment entailed by this diagnosis.

SURGERY.

461. Lumbar Anaesthesia.

RICHTER (*Hygiea*, February 28th, 1921) has investigated the results obtained by lumbar anaesthesia in the 601 cases in which this form of anaesthesia was adopted at his hospital since 1905. He found that the anaesthesia was complete in all but 5.8 per cent. of the total; the failures to induce complete anaesthesia referred almost exclusively to operations on the upper segments of the abdomen, while it was almost invariably complete in amputations below the hip. He did not attempt operations on the upper half of the body under lumbar anaesthesia, and he agrees with those authors who set the umbilicus as the level above which operations should not be performed under lumbar anaesthesia. He never experienced any fatality or serious accident, such as cessation of pulse or respiration, permanent paralysis, trophic disturbance or the like, as a sequel to lumbar anaesthesia. He associates this immunity to alarming complications with his careful selection of cases and his avoidance of Trendelenburg's position, in which patients are placed by most surgeons directly after the injection. The author keeps his patients horizontal, with the head propped up with a couple of pillows. Reviewing the experiences of thirty-four writers whose 26,446 cases of lumbar anaesthesia between 1917 and 1920 included twelve deaths (0.045 per cent. mortality), the author points out that practically all these deaths could be traced to the serious condition of the patient before the lumbar injection. Though the author finds lumbar anaesthesia both safe and comparatively effective, he tempers his advocacy of this method with the admission that recent advances in the technique of local anaesthesia have done much to displace lumbar anaesthesia. This has, however, its sphere of usefulness when, after an accident, for example, the surgeon cannot wait the fifteen to twenty minutes required for certain forms of local anaesthesia, or when the patient is disqualified by senile gangrene or other causes for general anaesthesia.

462. Tuberculosis of the Male Genital Tract.

BARNEY (*Amer. Journ. Surg.*, December, 1920) discusses the treatment of tuberculosis of the genital tract in the male. He believes that the epididymis is the primary focus, but that this is itself always secondary to a focus elsewhere in the body—most often in the lungs or hilus glands. He believes equally that tuberculosis of the prostate and seminal vesicles is almost invariably secondary to that of the epididymis. Primary tuberculosis of the prostate does exist, but it is extremely rare, and very few genuine cases have been recorded in the literature. Such a case has never been met with by Barney and his colleagues at the Massachusetts General Hospital. They have found that prostatic tubercle tends to spontaneous cure after epididymectomy, and do not think that radical operations on the prostate and vesicles are justifiable or necessary. The diagnosis of tuberculosis of the epididymis is often difficult; a gonococcal prostatitis may obscure the true nature of the disease in the epididymis. Barney believes that an exploration under novocain should be advised in doubtful cases. He describes two cases to emphasize the importance of this. In both, after much loss of time and palliation, orchidectomy was performed, and the enlargement proved to be a sarcoma springing from the testicle. The author holds that epididymo-vasectomy is the operation of choice, performed preferably under novocain. He has lost cases after operation from miliary tuberculosis, and believes the inhalation anaesthesia (ether) to have been largely responsible for this. Orchidectomy is rarely necessary; even if the testis is affected the diseased portion can be successfully removed in many cases. The second epididymis is involved in at least half the cases, and will need removal. The prostate and seminal vesicles, although early invaded, do not require direct operative measures, and will heal after the epididymal foci have been excised.

463. End-results of Operation for Varicocele.

DURING the period immediately preceding and after the entrance of the United States into the war, and while recruiting was in active progress, a large number of operations for varicocele were performed on young men in order to permit their entrance into the army or navy. As a result of one of these operations, in which the ligation of the veins was followed by the development of a hydrocele, a suit for alleged malpraxis was brought. DOUGLAS (*Journ. Amer. Med. Assoc.*, March 12th, 1921), after a study of the end-results of 303 operations for

varicocele at St. Luke's Hospital, New York, reached the following conclusions: The operative treatment of varicocele is often followed by hydrocele. Of a total of 303 operations, 76 patients were examined, 30 of whom, or 39 per cent., had a hydrocele; 40 reported by letter or telephone, and of these 7, or 17 per cent., stated that hydrocele had developed. Of the total of 106 patients examined or reporting by letter, 37, or 35 per cent., had hydrocele; 4, or about 4 per cent., had atrophy of the testicle, and there were two recurrences of the varicocele. He considered that the operation should not be performed except in those cases of very large varicocele giving marked symptoms in a non-neurasthenic patient—certainly not in the type of cases previously referred by the various medical examining boards for admission to the army or navy. If the operation is undertaken, the frequency of hydrocele as a complication should be explained to the patient as a protection to the operating surgeon. In the performance of the operation every care should be taken to avoid trauma to the veins of the cord and to prevent haematoma or the slightest infection, thus limiting thrombosis and also avoiding the ligation of the spermatic artery as well as the artery of the vas.

464. Acute Infections of the Pancreas.

SWIFT (*Boston Med. and Surg. Journ.*, February 10th, 1921) discusses the surgical treatment of pancreatic infections. The symptoms of acute pancreatitis are those of upper abdominal peritonitis, and they so closely simulate those of perforation of the gall bladder, duodenum, stomach, and acute cholecystitis, that it is impossible to be certain prior to operation. The patient's extremely ill appearance and grave condition are notable, but the only sure sign is the finding of fat necrosis or free blood-stained fluid, with palpable disease of the gland at operation. Success depends upon early and prompt operation and the provision of ample drainage. The coincident gall bladder disease must be dealt with at the same time. Post-operative history is more or less stormy from attacks of epigastric pain and vomiting, and the worst cases slough out part of the gland, the functional margin of safety of which is estimated at two-thirds of the gland substance. Notes of six cases with one death are given, pointing to the fact that, if diagnosed and operated upon early, acute pancreatitis is not so hopeless a condition as it has been hitherto considered.

465. Injections of Milk in Gonorrhoeal Conjunctivitis.

LINDBLAD (*Hygiea*, January 30th, 1921) states that for the past year and nine months every case of gonorrhoea of the eyes at the Sabbatsberg Hospital has been treated with intraglandular injections of boiled cow's milk in addition to the customary local treatment. To ascertain the value of this milk therapy, the merits of which have been loudly proclaimed, the author has compared the results of the pre-milk with the milk vogue. In the first category the patients received only local treatment. Of 13 adults in this category, 5 responded well, 5 badly, and 3 were hopeless at the beginning of treatment. In the second category the results were good in 1, fairly good in 2, and very bad in 1 case. The patients treated without milk became gonococcus-negative after an average of twenty-two days, and the milk-treated after ten days. Turning from adults to children, the author found that without milk treatment they lost their gonococci after seven to eight days, the milk-treated after ten days. The author concludes that, though this milk treatment may be beneficial in some cases, it does not deserve the reputation it enjoys in certain quarters.

466. Carcinoma of the Tongue.

PETERS (*Deut. Zeit. f. Chir.*, June, 1920) analyses the statistics of 48 cases of carcinoma of the tongue in Garré's clinic. Only 5 were admittedly heavy smokers and only 5 gave a history of syphilis. The characteristic of tongue carcinoma is its insidious, unnoted onset and the short duration of life of the sufferers. Secondary gland involvement occurs early and is of vital importance, as it progresses rapidly and may render operation difficult or impossible. Interference with the free movement of the tongue was a common sign. Results of operation were disappointing, not more than 6 cases being free from recurrence for over two years (15 per cent.). However, removal of the primary growth, even when lasting cure is not attained, lengthens the prospect of life by a few months. Propaganda is still urgently needed amongst practitioners to urge them to send cases of tongue ulceration for expert examination. Even if the patient is admittedly syphilitic, his ulcer may very well be carcinomatous.

OBSTETRICS AND GYNAECOLOGY.

467. Treatment of Febrile Cases of Abortion.

PRINZING (*Zentralbl. f. Gynak.*, March 19th, 1921) makes yet another contribution to the active discussion which has taken place in Germany during the past ten years with regard to the comparative value, in cases of abortion and parturition which are followed by pyrexia, of (1) conservative or expectant treatment and (2) operative treatment (by curetting). His verdict, based on an analysis of 436 cases of septic abortion, is given very definitely on the side of the rapidly increasing minority who advocate conservative or expectant treatment. Of these cases 145 received "active" treatment—that is, curetting performed during the febrile stage; 185 had "expectant" treatment—that is, the curetting was deferred to the second, third, or fourth day after the temperature had fallen to normal; the remaining 105 were given "conservative" treatment, consisting in rest and general medical attention, without recourse to operation. Prinzling again subdivides his cases according as the temperature at the time of admission to hospital was below or exceeded 100.4; he proceeds to detail the differences shown by the different groups with regard to the duration of the pyrexia, the persistence of the bleeding, the time required for cure, the number and character of the complications, and the mortality. In the cases treated "actively" the average time elapsing between admission and the disappearance of fever was 5.8 days (admission temperature having been less than 100.4) or 6.9 days (the temperature having been greater than 100.4). For cases treated "expectantly" the corresponding figures were 2.0 days and 3.1 days; for the "conservatively" and "expectantly" treated groups together, 3.9 days and 6.9 days. The average duration of the bleeding was 3.6 days and 4.3 days respectively in cases treated actively and expectantly—a slight advantage for active therapy which is more than counterbalanced by its drawbacks in other respects. On an average the treatment was completed on the twelfth day and the fifteenth day in actively treated cases admitted with temperatures respectively below and above 100.4; on the tenth and fourteenth days after expectant or conservative treatment. Parametritis, adrenal inflammatory tumour, exudate in the pouch of Douglas, thrombophlebitis, or other grave septic complication appeared in 15.4 per cent. (admission temperature below 100.4) and 24.5 per cent. (admission temperature above 100.4) of cases treated actively, but in the corresponding groups of those treated by expectant or conservative methods, in 5.3 per cent. and 14.7 per cent. only. In accordance with this diminished morbidity the mortality was *nil* among the cases admitted with a temperature below 100.4 and treated conservatively or expectantly, and 2.4 per cent. only among those who after admission with a temperature exceeding 100.4 were similarly treated; whereas operative treatment given during the febrile stage was followed by a mortality of 3.5 per cent. and 4.8 per cent. in the respective groups. Conservative and expectant treatment have, of course, the additional advantage that there is some possibility of a case of threatened abortion continuing to term; this is stated to have happened in six cases of this series.

468. Missed Abortion.

LITZENBERG (*Am. J. Journ. of Obstet. and Gynec.*, February, 1921) considers missed abortion to be a condition which is frequently overlooked. This is of very great importance in medico-legal cases where a woman is not living with her husband. The author quotes Matthews Duncan, who said that this condition illustrated the fact "that if you do not know of a thing, you are quite sure not to suspect it; and if you do not suspect a thing, you are almost certain not to find it." The author points out that, the trouble once having been suspected, the diagnosis will be made by careful measurements of the uterus at an interval of a month or six weeks.

469. Syphilitic Placentae.

MANDUELIN (*Gynec. et Obstet.*, vol. iii, 1921) asks the question, "Why are syphilitic placentae so seldom found in the placenta of a syphilitic foetus?" He quotes many authors who have occasionally demonstrated them in the vessels and other parts of the chorionic villi, but who have had negative results even in the cases in which the liver and other organs have been crowded with spirochaetes. He considers that the answer to the question lies in the fact that a very intense phagocytosis exists in the placenta.

470. Successful Extirpation of Primary Tubal Cancer.

THALER (*La Gynec.*, October, 1920) reported to the Vienna Gynecological Society two cases of primary carcinoma of the Fallopian tube. In striking contrast to the usual finding of speedy recurrence, the patients appeared to be cured at the end of three and a half and two years respectively. The first case was that of a multipara aged 40, who had pain and metrorrhagia, accompanied by pyrexia; the uterus was removed, together with the appendages, which were adherent to the intestine, and on the right side formed a partially cystic tumour, reaching to the umbilicus. A papillary carcinoma was found in the isthmus region of the right Fallopian tube. The second patient, a nullipara, suffered from post-elimastic bleeding, which was suspected to be due to sarcomatous transformation of a myoma. During the course of a vaginal hysterectomy the pouch of Douglas was found to be filled with carcinomatous masses extending from the right adnexa. A post-operative application of radium may have played some part in the apparent cure. Histologically the tubal growth in this case was an alveolar carcinoma.

471. Premature Births and Infantile Mortality.

FROM a consideration of the records of the Frauenklinik at Bremen, WIEGELS (*Zentralbl. f. Gynäk.*, March 5th, 1919) concludes that means for the reduction of infantile mortality due to prematurity or weakness at birth are to be found chiefly in (1) earlier and better treatment of parental syphilis; (2) restricted employment of induction of premature labour as a mode of terminating pregnancy in cases of contracted pelvis; (3) provision of institutions for care of foundlings and delicate children; (4) special medical care of premature children, carried out (in institutions) along lines which it should not be sought to standardize, but rather to adapt to the individual needs of different cases; (5) propaganda with regard to the importance of breast feeding. In the decennium 1909-18, of 4,532 births at the clinic, 548, or 11.9 per cent., were those of infants weighing less than 2,500 grams. The mothers of these were in 299 instances primiparae; in 207, multiparae.

PATHOLOGY.**472. Filtrable Bodies in Influenza.**

OLITSKY and GATES (*Journ. Amer. Med. Assoc.*, March 5th, 1921) give an account of the cultivation and appearances of certain minute bodies obtained from the filtered and unfiltered nasopharyngeal washings and lung tissues of patients suffering from epidemic influenza. The filtrates were cultivated in ascitic fluid containing a piece of rabbit's kidney, anaerobic conditions being maintained. About the fifth day a slight haziness was noted in the vicinity of the kidney tissue, but this became denser and progressed higher by the eighth day. After standing two weeks the cloudiness settled down and the fluid became clear. Film preparations from the bottom of the tube showed on staining with ripened alkaline methylene blue numerous minute bodies stained purple which were distinct from the precipitated granules of protein matter. These bodies have been observed in numerous primary cultures and in several hundred subcultures for as many as seventeen generations. They are comparable to the globoid bodies found in poliomyelitis, and are from 0.15 to 0.3 micron in length, being twice or three times as long as broad. They often occur discretely, sometimes in groups of two or three, and sometimes in clumps. The clumps range in size from that of a blood platelet to that of a polymorphonuclear leucocyte. They are decolorized by Gram's method. These bodies are destroyed by heating to 56 C. for half an hour. The cultivated bodies pass through V and N Berkefeld filters, and remain alive in sterile 50 per cent. glycerin for several months. They have been recovered from the lung tissues of animals injected with influenza nasal secretion. When the cultures are injected intratracheally into rabbits and guinea-pigs there is a rise of temperature, conjunctivitis, and leucopenia after twenty-four to forty-eight hours, a condition which lasts for one to three days.

473. Lymphoid Cells in the Blood in Acute Leukaemia.

JOLLY and LAVEDAN (*C. R. Soc. Biologie*, January 22nd, 1921) recommend the use of wet preparations in the study of abnormal blood corpuscles. They are accustomed to plunge the freshly spread slide at once into a fixative

solution. Their favourite fixative is a mixture of 30 volumes of 1 per cent. chromic acid, 10 volumes of 1 per cent. osmic acid, and a drop of acetic acid; the slide is fixed for two or three minutes, washed in running water, and stained with eosin-orange-toluidin. Such a technique is indicated where nucleated red corpuscles are present and in the study of leukaemic blood. The authors refer to a case of acute leukaemia in which there were about 600,000 leucocytes per cubic millimetre, all corresponding to an indifferent type of lymphoid cell with a large nucleus, which has been called by different writers, according to the theoretical idea held by them, lymphocytes, leucoblasts, or mycoblasts. In films dried and stained by the usual methods these cells are large, with enormous nuclei showing no clear chromatic network, with no visible membrane, slightly basophile protoplasm, numerous degenerate forms, but no mitotic figures. By the technique already mentioned, however, these cells appear much smaller, only a little larger than the red corpuscles and the small lymphocytes; their nuclei are very large and limited by a very distinct membrane; two or three characteristic nucleoli may be found; the chromatic network is not well developed, but is sometimes clearly visible though extremely fine; no degenerate forms are to be seen; and mitoses, though not numerous, can easily be found. In addition to these elements there exist true myeloblasts of larger size in which the protoplasm is definitely basophile, some lymphocytes, leucocytes, myelocytes, and occasional nucleated red cells. The lymphoid cell here described is difficult to place; it is indifferent, and cannot with certainty be classified as coming from the bone marrow or the lymphatic system. Probably we should not separate these two great classes of white cells as distinctly as has hitherto been the custom.

474. Intradermo and Subcutaneous Reactions in Hydatid Disease.

PONTARO (*Il Policlinico*, Sez. Med., November 1st, 1920), as the result of his researches, has come to the following conclusions: (1) The fluid of hydatid cysts has an antigenic value for the human organism. Experimentally it is possible to sensitize an individual who is not suffering from the disease, and to confer on the serum the property of fixation of the complement by successive inoculations of hydatid fluid. (2) Intradermic and subcutaneous inoculation of freshly withdrawn cyst fluid produces local reactions (Casoni's intradermo reaction and subcutaneous reaction) in patients with hydatid disease. (3) The doses suitable for the specific reaction are 0.20 to 0.30 c.cm. for the intradermo reaction, and 1 c.cm. for the subcutaneous reaction. (4) The cutaneous reactions are positive in a very high percentage of cases of hydatid disease in which the cysts are not suppurating; when the cysts are suppurating the percentage is very low. (5) The cutaneous reactions are quite as specific as the Ghedini-Weinberg reaction, but are more delicate and simpler to perform. (6) Attempts to produce a state of anaphylaxis in patients with hydatid disease by injections of vaccine have not hitherto been successful.

475. Blood Changes in Lead Workers

SELLERS (*Journ. of Indust. Hygiene*, February, 1921) records observations upon the changes in the blood in men who had been exposed to lead for a fairly long time. Blood taken from the ear or finger was examined for red and white cell count, haemoglobin estimation, and in films stained by Leishman's stain and methylene blue. In a very large proportion of cases there was found to be a diminution of haemoglobin and punctate red cells were present. The latter were frequently, though not constantly, found in men giving a history of blue line on the gums. Such punctate red cells were found very rarely and in very small numbers in healthy persons, and, though they occur in other diseases and cases of poisoning by other agents than lead, it is usually easy to recognize a film from a lead worker because of their presence in comparative number. The corpuscles containing the granules appear sometimes slightly larger than normal, and show an increased affinity for the blue stain. The granules are situated mostly in the periphery of the corpuscle. Further observations have shown that as a means of diagnosis and for the control of lead workers such blood examinations are unreliable as they do not afford a definite criterion one way or the other, since some cases of lead poisoning show no changes in the blood, and also definite changes may be present without any other sign of the disease. A blood examination, therefore, in a suspected case must be regarded as only one of many other pieces of evidence towards arriving at a diagnosis.

EPITOME OF CURRENT MEDICAL LITERATURE.

MEDICINE.

476. Pleural Effusions in Artificial Pneumothorax.

DUMAREST and PARODI (*Il Policlinico*, Sez. Med., January 1st, 1921) point out that the pleural effusions which occur in the course of artificial pneumothorax are not always of a tuberculous nature but may be due to various causes, the nature of which can be determined by cytological and clinical examination. The writers distinguish the following three groups: (1) Idiopathic pleurisy, characterized clinically by its early appearance, absence of constitutional disturbance and complete disappearance without sequelae; cytologically by eosinophilia; and lastly by the scanty albumin content and slight degree of coagulability of the effusion. (2) Tuberculous pleurisy, which is subdivided into (a) a benign form without constitutional disturbance and characterized by a scanty effusion with small albumin content and a cytological formula of large and later small lymphocytes, and (b) a malignant form, characterized by constitutional disturbance, a progressively increasing effusion, and cytological formula of large and later small lymphocytes without endothelial cells. (3) Septic pleurisy, characterized by an acute course with much constitutional disturbance and a cytological formula of polymorphonuclear leucocytes. Transitional forms may also occur.

477. STIVELMAN and ROSENBLATT (*Amer. Journ. of Med. Sciences*, February, 1921) call attention to multiple fluid collections occurring in the chest during artificial pneumothorax. The condition can only be detected by the characteristic fluid levels seen on x-ray examination, when one or more fluid levels are seen superimposed upon and parallel to the main effusion, and a fluid wave can be elicited on each level independently. Among thirty-two cases of hydropneumothorax five presented the condition, which appears to be due to sheet-like adhesions spreading hammock-like from the visceral pleura across the pneumothorax area to the chest wall; these act as a receptacle to catch the fluid secreted from the pleural surface above their insertion, and also part of the main effusion may become entrapped in them by change of posture. Two or more independent hydropneumothorax pockets may result from attempts to induce pneumothorax at different levels, or a localized spontaneous pneumothorax may occur adjacent to a pocket of artificial hydropneumothorax. The adhesions may be present prior to the induction of the pneumothorax and occasionally they may result from a thickened interlobar septum, or they may be newly formed as a result of organization of the exudate. Five cases are reported (with skiagrams), one due to spontaneous pneumothorax superimposed upon a limited induced pneumothorax, two due to hammock-like adhesions resulting from a pre-existing thickened interlobar septum, and two due to shelf-like adhesions formed by the organization of the exudate.

478. Artificial Pneumothorax in Pulmonary Tuberculosis.

RODANO (*Il Policlinico*, Sez. Med., January 1st, 1921) records the histories of 27 cases of pulmonary tuberculosis treated by artificial pneumothorax, and comes to the conclusion that this method is of undoubted efficacy under certain conditions, which may vary in different cases, a unilateral lesion even when advanced not being a contra-indication. The pleural effusion which frequently occurs during artificial pneumothorax does not usually aggravate the prognosis or delay recovery. If thoracentesis is carried out in such cases with proper precautions, it is not so dangerous as is generally supposed, and sometimes, especially in acute cases, may be of real benefit to the patient. Pleural oedema or gas embolism is the most serious complication of artificial pneumothorax, but the symptoms which at first are so alarming may subside without leaving any trace. In lesions of the left lung it is not uncommon for artificial pneumothorax to be followed by cardiac murmurs, which are always systolic in time and may last from a few days to a few months, and may even be accompanied by a distinct systolic thrill. Acute bronchial affections which occur during artificial pneumothorax usually subside rapidly and almost spontaneously without it being necessary to suspend the treatment. It is sufficient in such cases to make the refills at longer intervals. Haemoptysis, which may occur either at the beginning of

treatment or at an advanced stage, is not a contra-indication to artificial pneumothorax, but its treatment varies according to the case and the state of compression of the lung.

479. Effects of Friedmann's Tuberculosis Vaccine.

GRASS (*Deut. med. Woch.*, March 3rd, 1921) has collected several cases of tuberculosis treated by Friedmann's vaccine, all of which responded unfavourably, the responses in some cases amounting to disasters. Personally he has seen more than one such disaster, and the following case is particularly instructive, as Friedmann himself administered the vaccine. The patient was a married woman whose pregnancy was interrupted on account of active pulmonary tuberculosis. After the induction of abortion she felt well and was afebrile. An x-ray examination seemed to indicate that this was a suitable case for Friedmann's vaccine, which was accordingly given. A fortnight later she became very ill and developed a hectic type of fever. She was therefore admitted to hospital, where she died about two months later of bilateral caseous pneumonia. Another case was that of a medical man, who developed a tubercle of the hand as a sequel to a necropsy. In spite of Friedmann's vaccine the disease progressed slowly. Half a year later a second very small injection of the vaccine was given, and this was followed by an acute exacerbation of the tubercle. Ultimately the disease cleared up under diathermy. In a third case a moderately severe afebrile type of pulmonary tuberculosis developed into a febrile and rapidly progressive type ten days after an injection; within three months the patient was dead. The author comments on the fact that though Friedmann himself has treated an enormous number of cases with his vaccine, he has not published any disasters similar to those which unprejudiced observers apparently find to be quite common.

480. VAN TILBURG (*Nederl. Tijdschr. v. Geneesk.*, March 12th, 1921) reviews the literature of the subject of Friedmann's remedy for tuberculosis, and comes to the following conclusions: (1) The present method of administration of Friedmann's remedy is free from danger; (2) in some forms of surgical tuberculosis it appears to have a favourable effect in pulmonary tuberculosis it is very difficult to estimate its action owing to the capricious nature of the disease; (3) no decision is at present possible as regards its prophylactic value in children; (4) the present method of administration is probably not an ideal one—it is dangerous to dispense with other methods of treatment, especially the rest cure, and to depend upon Friedmann's remedy only; (5) the remedy has not fulfilled the great expectations entertained by Friedmann's admirers; (6) the way in which the remedy is advertised is reprehensible; (7) the clinician must say the last word as to its value.

481. The Tuberculosis Mortality in Vienna before and after the War.

PELLER (*Wien. klin. Woch.*, October 7th, 1920) states that a comparison of the years 1919 and 1913 and 1914 shows an increase in the general mortality, and still more so in the tuberculosis mortality in Vienna, and that the mortality among women has become higher than that among men. Before the war the mortality from tuberculosis among men was decidedly higher in every district of Vienna than among women. In 1919, on the other hand, in a considerable number of districts the mortality from tuberculosis among men was lower than that among women, in other districts the mortality among men was only slightly higher than that among women, and in only three districts was it considerably higher among men. The districts which were characterized by a considerable increase in mortality from tuberculosis were those which before the war were inhabited by a well-to-do population or by the middle classes. The poorer districts, though showing a larger number of cases than before the war, did not have such a large relative increase, possibly owing to the fact that during the war a large proportion of those affected in the poorer districts succumbed to the disease. The female population showed at all ages, with few exceptions, an increase in the deaths from tuberculosis from year to year. The amount of increase differed at various ages, being least between 20 and 40 and most marked between

15 and 20 and over 50. The increase in the tuberculosis mortality among the male population was smaller, with the exception of the age period 15-20. The highest mortality in men over 50 was reached in 1917.

482 Curability of Tuberculous Meningitis.

HARBITZ (*Amer. Journ. of Med. Sciences*, February, 1921) considers that tuberculous meningitis and tuberculosis of the central nervous system may be capable of cure, though it may be doubtful whether there was in any of the cases that recover inflammation at the base of the brain with partly gelatinous, partly purulent, exudate about the blood vessels and nerves. Observations go to show that tuberculous meningitis may heal, however, even in cases with rather extensive lesions with exudate and tubercle formation. Such curable form occurs in persons who have suffered from chronic and relatively benign forms of tuberculosis, though the most important factor is an increased resistance on the part of the body, with some relation to age. Sixty per cent. of cases occur in the first two years of life and are always fatal, cases of recovery being in older children and in adults. While epidemic meningitis generally becomes chronic with internal hydrocephalus, etc., tuberculous meningitis may heal without any serious defects even after extensive lesions.

483. Neo-salvarsan in Putrid Bronchitis.

SCHROEDER (*Acta Medica Scandinavica*, January 14th, 1921) records cases of putrid bronchitis in which the intravenous injection of neo-salvarsan in increasing doses (15, 30, 45 cc., at seven to ten day intervals) led to marked improvement, with a fall of temperature and diminution of expectoration. In one of his cases the disease had lasted five months: the temperature was high, and the sputum measured about 200 c.c.m. In the course of twenty-three days the temperature fell to normal under this treatment, and the sputum dwindled to three lumps a day, losing its putrid character at the same time. HANSEN (Ibid.) endorses the treatment of putrid bronchitis by salvarsan, regarding it as a definite advance in the treatment of this condition, and he refers to three cases in support of his views. HOLMGREN and HOLST (Ibid.) both express doubts as to the value of this treatment, although Holst has seen some temporary improvement follow. SCHNELL (Ibid.), on the other hand, is a hearty advocate of this treatment, and he mentions the case of a patient with gangrene of the lung, following pneumonia. The temperature was high and the abundant expectoration putrid. Many different methods of treatment were tried without effect, but after three injections of neo-salvarsan the temperature fell rapidly, the smell and the quantity of the expectoration diminished, and the patient recovered.

484. Diabetes and Trauma.

DIEZ (*Il Policlinico*, Sez. Prat., March 28th, 1921) has collected the following statistics showing the frequency of trauma preceding diabetes: In 20 out of 225 cases (Griesinger); in 2 per cent. out of 4,063 cases (Frichs); in 1.4 per cent. out of 938 cases (Seeger); in 5 per cent. out of 116 cases (Ebstein); in 1 per cent. out of 300 cases (Senator); in 5.6 per cent. out of 669 cases (Külz-Rumpf). According to Lépine trauma is a cause of diabetes in 5 per cent. of all cases, but not an exclusive cause, as in many cases there is an hereditary predisposition. Cantani found a history of trauma in 10 per cent. out of 1,004 cases of diabetes, but, as Ferranini observes, cases were included in which diabetes had occurred fifty years after the trauma. According to Brouardel and Richardière, traumatic diabetes is commoner in men than in women, while Lépine considers that children are most likely to be affected. Diez, however, thinks that these statistics have only a relative value, because the observers had not made an exhaustive inquiry into the etiology. While all writers admit the existence of a traumatic transitory glycosuria, some, like Jaccoud, deny the existence of a true traumatic diabetes, and consider that trauma only rouses pre-existing diabetes into activity. Others believe in the possibility of the development of traumatic diabetes when an hereditary or acquired predisposition is present. The opinion generally held is that of Richardière and Sicard, who maintain that the action of trauma is merely to awaken dormant disease. The region affected by the trauma is important. In 33 cases Brouardel found cranial trauma in 17, spinal trauma in 5, and traumata of other parts of the body in 11. The importance of cranial trauma is generally admitted. It is always severe, sometimes accompanied by fracture, in most cases with concussion. In some cases, however, no appreciable damage to the nervous system has been detected. Spinal trauma may be of various kinds, such as a fall on the neck, back, or lumbar region, or contusions in various parts of

the vertebral column. Sometimes there is a fracture and dislocation, while in other cases there is no surgical lesion, and only spinal concussion is responsible. According to Brouardel and Richardière, peripheral trauma of any degree is sufficient to cause traumatic diabetes, and it is not necessary that the part injured should correspond to a region in which the nerve centres are situated. Traumatic diabetes often appears early, sometimes within three days or a week of the injury, but there may be an incubation period of several weeks or as much as sixteen months. It is generally agreed that if diabetes occurs two years after an injury it has no relation to the trauma. The onset may be acute and the subsequent course rapid or slow, or it may be insidious and progressive from the first. The symptoms are the same as those of spontaneous diabetes.

SURGERY.

485 Renal Tuberculosis.

CASPARI (*Journ. d'Urol.*, Nos. 5-6, Tom. x) records 16 cases, 11 of which occurred in women and 5 in men. The patients' ages ranged from 18 to 57, the average age being 35. Anatomical examination showed that surgical tuberculosis of the kidney usually starts in the medulla, the pyramids being the favourite site; in only 2 cases was a cortical origin probable. In 8 cases the size of the kidney was not affected, in 5 it was enlarged, and in 2 it was unusually small, possibly congenitally so. In renal tuberculosis symptoms of cystitis predominate, consisting of frequent micturition, pain, pyuria, and haematuria. The renal symptoms are inconstant and less pronounced, and consist of pain in the back and in the right or left hypochondrium, sometimes radiating into the abdomen or the corresponding lower limb. The general condition is usually markedly affected, most of the patients showing loss of flesh, and some being subject to febrile attacks. On palpation the affected kidney is sometimes found to be large and tender and even movable, but often it is not detected by palpation, in spite of deep pressure. In exceptional cases the ureter is found as a round, hard, and exquisitely tender cord on abdominal palpation. The urine is turbid, purulent, and constantly acid. Caspari found tubercle bacilli in the urine in 12 out of his 16 cases. The other methods of detecting renal tuberculosis are cystoscopy and catheterization of the ureters. Cystoscopy shows that the lesions are most pronounced on the half of the bladder corresponding to the affected kidney, especially in the neighbourhood of the ureteral orifice. Catheterization of the ureters gives valuable information as to the condition of the ureter on the affected side. In most cases it shows strictures at the lower part of the duct which, in most cases, are impassable. These cicatricial lesions are almost pathognomonic of tuberculosis. Ureteral catheterization also enables a separation of the urine from the two kidneys to be made for naked eye, microscopical, bacteriological, and chemical examination. The urea and chlorides are deficient in the urine from the affected kidney. Treatment consists in nephrectomy as soon as the diagnosis is made, provided the kidney on the opposite side is healthy or at least functionally competent. The possibility of there being only a single kidney must not be forgotten.

486. Hydatid Thrill.

It is very generally held that a peculiar and characteristic thrill is pathognomonic of hydatid cysts. The cause of this thrill has very reasonably been attributed to the presence of hydatid vesicles in the fluid contents of the cyst. A similar thrill has, however, been felt in cysts containing nothing but fluid—as in some hydatids, ovarian, and broad ligament cysts, even in ascites. BÉRARD and DUNET (*Journ. d'Urol.*, January 1st, 1921) report a case of hydronephrosis of the right kidney which was mistaken for a hydatid cyst of the right lobe of the liver because of the characteristic "hydatid thrill" which they elicited from it. At operation the diagnosis was corrected, and nephrectomy performed. The case has a further interest, for two years previously the patient appears to have ruptured this hydronephrosis intra-abdominally by violent muscular effort, a most rare occurrence. The tear healed spontaneously. Bérard and Dunet refer to other French workers who have discussed the genesis of "hydatid thrill." They agree with Millan and Davaine, who believe that a thrill is likely to arise when fluid of a density corresponding to that of water is enclosed under high tension in a thin-walled cyst. The thrill is therefore not pathognomonic of hydatid cysts, though these most commonly fulfil the conditions necessary for thrill production.

487.

Hernia of Linea Alba.

VILLARD (*Lyon Chir.*, November-December, 1920) discusses the pathogenesis and pathological anatomy of hernia of the linea alba. He states that these herniae are herniae of the round ligament of the liver. It is this which explains the paradoxical intensity of the disorders engendered by a lesion which appears trivial. The dyspepsia, the pain and its wide radiation are due to traction on the anterior hepatic ligament, which when herniated behaves like a pathological adhesion. Villard points out (as has Moschowitz) that a peritoneal sac is often lacking in the hernia, and when present is an accessory after and not before the fact. Until it was recognized that hernia of the linea alba was essentially a hernia of the fat walled in between the two layers of the falciform ligament it was difficult to understand why operation should bring such striking relief. When one realizes that resection of the herniated fat has released the tension on this ligament and the liver the good results of operation are better understood. Villard thinks that these herniae are always congenital, and are supra-umbilical because of the later closure of the upper mid-abdomen.

488. Stoffel's Operation for Spastic Paralysis.

GILL (*Journ. of Orthopaed. Surg.*, February, 1921), from an experience of 32 cases, believes the Stoffel neurectomy to be the best single operation in cases of spastic paralysis, because it is applicable to a great number of cases with uniformly good results, is not severe, and is not followed by any ill effects. Operations on the popliteal nerve were uniformly successful in relieving the contracture of the tendo Achillis, thereby enabling the patient to stand and walk with the foot firmly on the floor, thus greatly improving the gait. Operations on the obturator nerve corrected the adductor spasticity, and those on the sciatic nerve relieved the hamstring contracture. Median nerve operations lessened the spasticity or corrected the deformity of the hand in varying degrees, the results being more uncertain than those obtained in the lower extremity. When possible, a preliminary course of treatment should be undertaken prior to operation with a view to improving function as far as possible, and to enable the surgeon to decide better what extent of operation is needed. Through a small incision the nerve is freed from surrounding tissue, and the various bundles are tested by an electrode before excision. In cases of spastic paralysis of the lower extremities in which the contractures disappear under an anaesthetic no after-fixation is necessary, but if forcible correction is required to reduce the contracture the limb should be fixed in an over-corrected position for two or three weeks. At the end of a week, as soon as the wounds have healed, gymnasium instruction in muscle training and walking is commenced, but care must be taken to avoid over-fatigue, and active movements must not be overdone.

489. Fractures of the Lower End of the Radius.

HITZROT and MURRAY (*Amer. Journ. of Surg.*, February, 1921) investigated the factors that influence prognosis in fractures at the lower end of the radius. These are found to be the character and location of the line of fracture, the degree and variety of displacement, the degree and time of reduction, the after-treatment, and the age and temperament of the patient. Those cases which presented the greatest amount of disturbance in the radio-ular joint were found to show some deformity even when slight; and disability, most marked in supination and pronation, was a common result, especially in elderly persons. Such fractures may be separated into different groups according to the line of fracture as determined by x ray, and the earlier and more complete the reductions for similar types the better will be the cosmetic and functional results. Age has a definite effect on prognosis, similar bone injuries producing more disability over 50.

490.

Ulcer of the Cornea.

TUTTLE (*New York Med. Journ.*, February 19th, 1921) discusses the treatment of ulcer of the cornea occurring in children and young adults, and in adults over 40 years of age. The phlyctenular variety is the one most commonly seen in children and young adults, largely as a local expression of a systemic disturbance—for example, a weak and scrofulous constitution, following the exanthematous diseases, or in tuberculosis or hereditary syphilis. Treatment consists generally in removal of the cause, and locally a saturated solution of boracic acid as a cleansing wash followed by one drop of a 25 per cent. solution of argyrol instilled into the eye every three or four hours. Finely powdered calomel dusted on to the ulcers once a day hastens healing, and a compound yellow oxide and

adrenaline ointment is useful. Suitable glasses should be provided. Over 40 years of age the ulcers are usually of the serpiginous or creeping variety, accompanied by an iritis, and rapidly extending. Prognosis is good if seen early. Foreign bodies, or cilia rubbing the globe, should be removed, and the conjunctiva flushed with a 1 in 5,000 bichloride solution. Under cocaine every part of the ulcer should be touched with the electro-cautery until all necrotic and infected tissue is destroyed, and the eye again flushed with the bichloride solution, a 1 per cent. yellow oxide and atropine ointment placed inside the lids, and the eye bandaged. The patient should be kept in bed and not allowed to remove the dressing himself, daily cleansing with boric acid solution being carried out. All abrasions of the cornea are serious, and require prompt and thorough treatment by the electro-cautery.

OBSTETRICS AND GYNAECOLOGY.**491. Labour Obstructed by Fixation of Retroverted Uterus.**

POTOCKI (*La Gynéc.*, October, 1920) relates the case of a primipara, aged 38, in whom at the onset of labour at term the foetal head was found at the right side of the fundus uteri: the left half of the uterus was less perfectly developed than the right. An effort to perform external version having failed, hydrostatic dilatation by a bag was attempted, but with little success; it was possible, however, to bring down a leg. Next day, the child being dead and the uterus in a state of contracture, abdominal hysterectomy was performed; the fundus and posterior surface of the uterus were found to be adherent to the iliac and pelvic colon. Reviewing the treatment, Potocki points out that by a Caesarean operation performed on the first day of labour it would have been possible to secure a living child, and that as it was (the child being dead) the freeing of the uterus at operation would have been considerably simplified by previous removal of the limb which had been pulled down.

492. Spontaneous Haematomata of the Abdominal Wall.

BAUTREISEN (*Zentralbl. f. Gynäk.*, March 12th, 1921) summarizes from the literature cases of spontaneous haematoma of the abdominal wall occurring in connexion with pregnancy and the puerperium. Such haematomata may be unilateral or bilateral and are generally unaccompanied by pyrexia; they are usually situated in the substance of the rectus abdominis muscle. They appear suddenly after a sharp muscular effort; their occurrence is usually to be correlated with the muscular hyperaemia and stretching which accompany pregnancy, but in a case recorded by Stoekel the finding of petechiae suggested a purpuric etiology. The majority of cases have been treated by incision and evacuation of the clot, but Vogt's patient, in whom bilateral haematomata appeared in the lower end of the rectus muscle a few hours after labour, was found to present no abnormal signs, subjective or objective, at the end of four weeks' conservative treatment. The case of this condition recorded by Banereisen is chiefly interesting with respect to etiology. At the date of appearance of the haematomata the patient was still suckling her youngest child (2 years old), but the genital organs appeared to be normal; at operation, performed within forty-eight hours, staphylococci were found in the exudate. Spontaneous haematomata of the abdominal wall may lead to considerable difficulty in diagnosis, and in some cases have been regarded, in the first instance, as pediculated ovarian cysts or as tumours of the colon.

493. Subperitoneal Shortening of Round Ligaments.

GRAD (*Amer. Journ. of Obstet. and Gyn.*, February, 1921) describes a new operation for retroverted uterus, in which he opens the broad ligaments and sutures the uterine end of the round ligaments to the internal abdominal rings. He often combines this operation with plication of the utero-sacral folds and a temporary suturing of the fundus to the anterior abdominal wall. He does not seem to agree with the accepted idea that very few uncomplicated retroversions give rise to symptoms.

494.

Fibroids Complicating Pregnancy.

A DISCUSSION on the subject of fibroids complicating pregnancy took place at a meeting of the Obstetrical and Gynaecological Society of Nancy (*Rev. méd. de l'Est*, January, 1921), and among those taking part VAUTRIN came to the conclusion that in the early half of pregnancy it was only necessary to interfere when the growth caused com-

pression or caused incarceration of the uterus. In such a case he advised laparotomy and removal of the fibroid, if it were not too much imbedded in the wall of the uterus. In the presence of adhesions hysterectomy, disregarding the pregnancy, is the correct line of treatment. In the second half of pregnancy no operation should be done until term; then Caesarean section can be performed, followed by hysterectomy at once, or later. FRUHNSHOLZ quoted a number of successful cases, in some of which labour was not interfered with; in others the child had to be destroyed. VERMELIN noted that small fibromyomata sometimes caused delay in labour without any actual obstruction being present.

495. Carcinoma Vulvae.

FROM an analysis of forty-four cases of cancer of the vulva treated at the Kiel Frauenklinik, GIESECKE (*Zentralbl. f. Gynäk.*, March 12th, 1921) concludes that operative treatment gives better results than x-ray or radium therapy. Of the forty-four cases, twenty-five were older than 60, and eleven older than 70, while 18 per cent. were nulliparous. The operative procedure recommended is excision of the vulva with bilateral extirpation of the lymphatic glands of the groin; recurrence of the disease occurred in four only of fifteen patients thus treated, as compared with five patients out of eight in whom hemi-amputation of the vulva, together with removal of glands on one or both sides, was performed. Lasting cure, as shown by five years' freedom from recurrence, was attained in 42 per cent. of operable cases; the primary mortality was 12 per cent. In two cases the pelvic glands were removed at laparotomy. Forty per cent. of the twenty-three cases in which the excised inguinal glands were examined microscopically showed evidence of carcinoma.

PATHOLOGY.

496. The Intradermo Reaction in the Diagnosis of Hydatid Disease

SERRA (*Il Policlinico*, Sez. Chir., January 15th, 1921) states that Casoni's intradermo reaction for the diagnosis of hydatid disease consists in the injection into the dermis of 0.5 c.c. of clear hydatid fluid obtained from an ox or sheep. In positive cases, within a few hours' time, there appear at the site of inoculation a more or less extensive erythema, pruritus, local rise of temperature, and oedematous infiltration. The reaction lasts some days, and even a week. A control test with injection of 0.5 c.c. of normal saline solution is carried out on the opposite arm. Serra regards Casoni's reaction as a simple method within the reach of all. It is never positive in other diseases for which the echinococcus is not responsible, and it never gives rise to unpleasant results. The few cases in which the reaction is negative in spite of the presence of a hydatid are to be attributed either to conditions inherent in the cyst wall, such as calcification or abnormal thickening, or to previous suppuration of the cyst, which leads to the disappearance of the antigenic properties.

497. Relation between Haemoglobin and Number of Blood Cells.

GRAM (*C. R. Soc. Biologie*, January 22nd, 1921) gives a method for determining the corpuscular volume in blood and the relation between this volume and the haemoglobin and the number of cells. This is obtained by mixing 0.5 c.c. of an isotonic 3 per cent. solution of sodium citrate with 4.5 c.c. of venous blood and centrifuging the mixture in a graduated tube for ninety minutes at 3,000 revolutions a minute. The percentage volume is got by multiplying the amount of the precipitate by 100 and dividing by the quantity of blood in cubic centimetres. In normal men the percentage volume varies between 51 and 41, and in normal women between 45 and 36. The percentage volume of the corpuscles is directly proportional to the percentage of haemoglobin in normal cases, and in pathological cases approximately so. The examination of 611 cases of all kinds showed that 100 per cent. of haemoglobin (with 18.5 per cent. oxygen capacity) corresponds to a cell volume of 47.1 per cent. of the whole blood. A blood count of 5 million normal erythrocytes corresponds to a volume of 42-43 per cent. The "volumetric index" (the relation between the volume of corpuscles and their number) is given by the formula: percentage volume multiplied by 0.12 and divided by the number of corpuscles per cubic millimetre. The values of the volumetric index are closely related to those of the

colorimetric index. It is always to be borne in mind, as Gram points out, that the number of corpuscles corresponding to 100 per cent. of haemoglobin is not 5 millions, as is commonly supposed, but 5½ millions per cubic millimetre. Consequently the colorimetric index varies between 0.8 and 1, with an average of 0.9. Gram compared the volumetric and colorimetric indices in 550 cases which he divided into three categories: (1) 387 cases with a normal colorimetric index with an average of 0.9, in which the volumetric index was 1 on the average; (2) 36 cases with an average colorimetric index of 0.6, giving a volumetric index of 0.8; and (3) 127 cases with an increased colorimetric index averaging 1.45 in which the volumetric index was found to be 1.5. In the normal blood there is a difference of 0.1 between the two indices, which he attributes to the false data on which the haemoglobin index is usually calculated. The conclusion to be drawn is that the pathological differences of the haemoglobin index are essentially due to variations in the mean volume of the cells. In simple anaemias with low index the haemoglobin content per unit of volume of corpuscles is slightly below the normal; on the other hand, in cases of pernicious anaemia with high index the haemoglobin content is slightly above the normal.

498. The Etiological Significance of *B. proteus vulgaris* in Cholera Infantum.

PUPILLI (*Ann. d'Igiene*, December, 1920), as the result of his experiments, comes to the following conclusions: (1) Small laboratory animals, such as rabbits, guinea-pigs, and puppies, which have been given large or small doses of *B. proteus* cultures by the alimentary canal do not show symptoms resembling cholera infantum. The experiment was also negative when an attempt was made to favour the pathogenic action of the organism by causing an abnormal condition of the alimentary canal by alkaline substances or purgatives. (2) The death of small animals which had been made to ingest large doses of *B. proteus* cultures, accompanied by alkaline substances or purgatives, could be attributed to the toxic action of the organisms (endotoxins). Sucking rabbits showed less resistance to the action of *B. proteus*, and it was possible to kill them even with small doses of the culture given by mouth without first causing any artificial changes in the gastro-intestinal functions. These experiments show that *B. proteus*, though not constituting the etiological agent of cholera infantum, may have some importance in the pathogenesis of this disease when conditions are present to favour its development.

499. Jaundice following Injection of Salvarsan in Non-syphilitic Cases.

GOLAY (*Rev. méd. Suisse rom.*, November, 1920) records three cases of jaundice which developed from two to three months after injection of novarsenobenzol in non-syphilitic patients. The Wassermann reaction was negative in all, the diseases for which they were treated being lupus erythematosus, erythema multiforme, and soft chancre respectively. These cases prove that syphilis has nothing to do with the appearance of jaundice after the use of arsenical preparations. Golay does not think that the jaundice in these cases was a mere coincidence and was of the ordinary catarrhal variety, first, because he had not seen a single case of jaundice at the Geneva dermatological clinic which had not been preceded by injections of arsenical preparations, and secondly, because the jaundice in each case appeared about the same time after the injection. He therefore concludes that the jaundice was due to the salvarsan.

500. Auto-anaphylaxis in Paroxysmal Haemoglobinuria. SCHIASSI (*Il Policlinico*, Sez. Med., Fasc. 9 and 10) records the case of a woman with a positive Wassermann reaction, who, during an attack of paroxysmal haemoglobinuria caused by a cold bath, showed a considerable diminution of the coagulability of the blood and a transient leucopenia of high degree, followed a few hours later by leucocytosis. In various incomplete attacks leucopenia was constant. By moderating the action of the cold, incomplete attacks—that is, attacks without haemoglobinuria—could be produced, the principal symptoms being diminution of the number of the leucocytes, nausea, and fever. It was impossible to reproduce two attacks in the course of the same day in spite of the constant presence of haemolysin and complement, because the first experiment which was followed by an attack caused a desensitization to the action of cold. Schiassi attributes the acute renal lesion in the attack followed by haemoglobinuria to occlusion of the renal tubules by granular detritus. Complete recovery took place under antisyphilitic treatment exclusively.

EPITOME OF CURRENT MEDICAL LITERATURE.

MEDICINE.

501.

Infantile Scurvy.

COMBY (*Bull. et Mém. Soc. Méd. des Hôp. de Paris*, March 3rd, 1921) states that though infantile scurvy has been familiar to paediatrists since the description given by Thomas Barlow in the *Medico-Chirurgical Transactions* in 1883, general practitioners are too apt to overlook it. From an experience of 72 cases he has found that in 9 out of 10 patients the disease has not been recognized before the child was brought to him. Since the war infantile scurvy has become more frequent from two causes: (1) The scarcity of fresh milk and the necessity of employing preserved milk and various infant foods; (2) failure on the part of the practitioner to recognize the symptoms of scurvy and an ignorance of its causes and neglect of prophylaxis. The diagnosis is established by the three following points, which should always be borne in mind in the case of a child who has been ailing for some little time and has been treated by various methods without success: (1) Artificial feeding for six, eight, or ten months with sterilized or condensed milk or infant foods. (2) Pains in the bones, manifested by loss of power in the lower limbs and crying when they are moved—a sign invariably present. (3) Ecthymoses in the gums. This sign, which is pathognomonic, is unfortunately not constant. It was absent in 16 out of Comby's 72 cases, or in 22 per cent. Prophylaxis consists in giving a child who has been fed on sterilized or condensed milk for some months a small quantity of orange juice, grape juice, or lemon juice sweetened with sugar, every day. Treatment consists in substituting boiled fresh milk for preserved milk and giving from 1 to 3 teaspoonfuls of orange, grape or lemon juice daily.

502. The Hydrocephalic Form of Cerebro-spinal Meningitis in Infants.

ACCORDING TO CAUSSADE and RÉMY (*Paris méd.*, February 12th, 1921), infection of the cerebral ventricles is a frequent cause of the failure of specific treatment in cerebro-spinal meningitis. It may be observed at all ages, but it is of most interest in infants, in whom it is characterized by definite signs and symptoms, instead of being latent as in the adult, and is more amenable to treatment. A characteristic feature of the hydrocephalic form of cerebro-spinal meningitis in infants is the long duration of the latent stage, the condition being at first mistaken for gastric derangement and respiratory catarrh. The development of hydrocephalus, which is invisible in the adult owing to the inextensibility of the skull, is shown in the infant by progressive increase in size of the skull, widening of the fontanelles, separation of the sutures, softening of the skull bones (craniotabes), lowering of the eyeballs, and development of a well-marked venous circulation on the scalp. The anterior fontanelle is in a condition of permanent tension and does not sink down, even when cerebro-spinal fluid is withdrawn by lumbar puncture and all pulsation in it ceases. As regards treatment, no benefit can be derived from lumbar puncture or upper vertebral puncture; the only method of any avail is puncture of the ventricles. The quantity of fluid to be withdrawn varies with the case, the more turbid the fluid the greater the amount to be removed. The amount of serum to be injected depends on the amount of cerebro-spinal fluid removed. The injections should be made alternately into each ventricle every other day. When possible, it is advisable to perform cerebro-spinal lavage with antimeningococcal serum. For this purpose lumbar puncture is performed at the same time as ventricular puncture, and the serum is injected slowly into the lateral ventricles until it escapes by the lumbar needle.

503 Infective Processes in the Teeth and Internal Diseases.

ANTONIUS and CZEPA (*Wien. Arch. f. inn. Med.*, February 21st, 1921) made a systematic study of the connexion of infective processes in the roots of the teeth with internal diseases, and found that of 225 persons suffering from various diseases, such as renal disorders, gastro-intestinal complaints, rheumatism, including endocarditis, neuralgia, acute respiratory disorders, and cholelithiasis, 148, or 66 per cent., showed chronic inflammatory changes in the roots of the teeth. It was noteworthy that disease

of which the etiology was not uniform, such as nephritis and rheumatic disorders, formed the bulk of these cases. Hitherto tonsillitis has been regarded as the most frequent cause of these diseases. The writers' investigations, however, showed that septic foci in the teeth were twice as common as chronic tonsillitis in these cases. Now, if chronic inflammatory changes in the tonsils are to be regarded as responsible for the origin of these diseases, it is only logical to attach etiological importance to the much more frequent occurrence of septic foci in the teeth. The connexion of infective foci in the teeth with internal diseases was difficult to prove, as only 39 of the 225 cases submitted themselves to thorough dental treatment. The improvement, however, which resulted in these cases justified the writers in drawing attention to occult foci of suppuration in the teeth and in recommending a careful x-ray examination of the teeth in all diseases, as they are convinced that in a large proportion of these cases the teeth will be found in a morbid condition, and that thorough dental treatment will result in a cure or at least improvement.

504.

Oral Symptoms of Disease

Dr Morgagny (February 5th, 1921) succinctly reviews the oral symptoms which may be found in various diseases. It reads rather like a catalogue; beginning with the appearance of the tongue in various dyspeptic disorders, the writer goes on to mention the scarlatiniform tongue, Koplik's spots, tuberculous ulcers, syphilitic lesions, gonorrhoea—seen rarely in newborn children and appearing as a yellowish deposit on the oral mucosa. Changes associated with blood diseases—pernicious anaemia, scurvy. Dryness of the mouth in diabetes and pyorrhoea—frequent as a complication in diabetes. Oedema as a complication of uraemia. Drug eruptions (usually appearing as herpetic vesicles in the mouth) from antipyrin and quinine; mercurial stomatitis, the blue line of plumbism; various forms of aphthous stomatitis. Actinomycosis, sprue, epulis: affections of the salivary glands, parotitis; various nervous affections, for example, paraesthesia, paralysis, hysterical globus. Amongst disturbances of secretion he mentions sialorrhoea and the rare xerostomia, where there is no salivary secretion. Perforating buccal ulcer may occur as a complication of tabes. Dental trouble—caries, first dentition, rickets, syphilis, scrofulosis; and finally brief reference is made to factor of the mouth, which is usually of local origin—due to tonsillary or dental trouble.

505. Injections of Turpentine in Pemphigus.

BRENNING (*Deut. med. Woch.*, February 17th, 1921) has treated three cases of pemphigus with injections (presumably subcutaneous) of turpentine, and he expresses great satisfaction with the results. The improvement effected was the more remarkable as, in his experience, pemphigus is a very intractable condition. One of his cases was that of a servant girl, aged 22, who was admitted to hospital with severe pemphigus. Almost the whole body was covered by vesicles, so that she could not lie comfortably in any position. Her mouth, the tongue included, was also involved, and she had great difficulty in taking food. After three weeks of futile treatment with various remedies, 0.5 c.cm. of a 20 per cent. solution of oil of turpentine was injected, and the same dose was repeated two days later. A third injection, this time of 1 c.cm., was given three days later. After the fourth injection no new eruptions occurred, but convalescence was protracted owing to the slow healing of the erosions left by the vesicles. The author adds that the injections caused no discomfort, and he believes that they were the cause of the patient's recovery in every case.

506 Concentration of Blood, Fever, and Loss of Weight in the Newborn.

UTHEIM (*Norsk. Mag. for Læger og Bskere*, February, 1921) has examined the records of 400 confinements in a maternity hospital, and has found that in 21 per cent. the temperature of the newborn infants was raised. The average loss of weight during the first few days of life was about 500 grams, and the frequency of fever increased with the amount of weight lost. To determine the changes in the concentration of the blood during the first few days of life the author carried out refractometric

examinations of the blood drawn from the heels of twenty-eight normal infants, the test being repeated daily till the ninth day. Little or no change was observed in the concentration of the blood. No constant relation could be found between the loss of weight and the concentration of the blood, nor between this and a rise of temperature. The author concludes that the loss of weight is a perfectly physiological and necessary process, representing as it probably does the disarding of fluids which have become superfluous under the conditions of extrauterine life. As for the rise of temperature, several possibilities are discussed, and the author suggests that the causes may be different in different cases. One of these causes is probably the newborn infant's yet imperfect heat-regulation mechanism. Toxic absorption from the intestine and the excretion of certain substances by the kidneys may also cause a rise of temperature.

507. Acute Arthritis in Infants.

JOHNSON (*Amer. Journ. of Dis. of Children*, February, 1921) records the study of 73 consecutive cases of acute arthritis admitted to hospital during the last fifteen years. The invasion of joints and periarticular tissues by pyogenic organisms is not rare, the joint inflammation being usually secondary to an infection of the epiphysis, though in many instances the inflammation spreads from the epiphysis to the periarticular tissues without affecting the joints proper. Considerable swelling, with or without suppuration, tenderness, redness and a great amount of induration, were the clinical manifestations. In only 32 of the cases could there be said to be any definite source of infection. Males predominated, and in the females vaginitis did not appear to be as common a cause of arthritis in infants as is generally supposed. The younger the infant the greater seems to be the susceptibility to purulent arthritis. The principal organisms responsible for infection were found to be the staphylococcus and the pneumococcus. The streptococcus and gonococcus were found to be more prone to affect multiple joints, while the pneumococcus seemed limited to one or two joints. Prognosis is not good and is affected by age, the older the child the better being the chance of recovery.

508. The Renal Test Meal.

ACCORDING TO FROMM (*Albany Med. Ann.*, November, 1920), the renal test meal consists of a carefully composed dietary regimen of twenty-four hours' duration in three separate meals. It contains approximately 13.5 grams of nitrogen, 8.5 grams of sodium chloride, 1.760 c.cm. of fluid, and a considerable quantity of purin material in the form of meat, soup, tea, and coffee. All these substances act as diuretics, and it is on the mode of excretory response to such stimuli that the interpretation of the test depends. The test meal yields the following results in the different types of renal disease: (1) Chronic interstitial nephritis. In early cases nocturnal polyuria is usually the first sign of renal impairment. In advanced degrees of interstitial nephritis the following factors indicate renal insufficiency: (a) Marked fixation and lowering of the specific gravity; (b) a diminished total output of sodium chloride and nitrogen; (c) a tendency to polyuria for the whole twenty-four hours; (d) a night urine showing an increase in volume, lowering of the gravity, and a concentration of nitrogen under 1 per cent. (2) Chronic parenchymatous nephritis. The characteristic findings in these cases are as follows: (a) The specific gravity tends to be high and fixed; (b) there is a diminished output of sodium chloride and water; (c) nocturnal polyuria is present; (d) there is practically a normal excretion of nitrogen. (3) Renal congestion resulting from cardiac decompensation. The test meal in such cases is followed by the following results: (a) A fixation of gravity about the level of 1020; (b) a diminished output of sodium chloride; (c) a diminution in the amount of the day urine; (d) a normal nitrogen elimination; (e) a normal night urine.

509. Subcutaneous Oedema in Sero-fibrinous Pleurisy.

ACCORDING TO LUSSANA and ARRIGONI (*Il Policlinico*, Sez. Prat., February 14th, 1921), who record an illustrative case, subcutaneous oedema may be caused by a non-suppurative sero-fibrinous pleurisy. The oedema may be confined to the base of the thorax, and to one side only, or be unilateral and extend from the base of the thorax to the sacrum and lower part of the trunk, presenting all the characters of oedema due to stasis. The explanation of the oedema, according to the writers, is to be found in a fibrino-plastic effusion occurring in the mediastinum, causing compression, traction, and subsequent occlusion, to a greater or less extent, of the veins in the posterior mediastinum.

SURGERY.

510. Simulation of Appendicitis by Acute Anterior Poliomyelitis.

DRBS (*Schweiz. med. Woch.*, March 17th, 1921) records three cases occurring in the same month in which the symptoms of acute anterior poliomyelitis simulated those of acute appendicitis so closely that this was diagnosed and laparotomy performed. Only a few days after the operation did flaccid paralysis develop and the true nature of the disease become evident. While admitting that these cases showed blunders on the part of the surgeon, the author insists that the rule of operating on acute appendicitis at the earliest possible stage is excellent, although it entails the inclusion of a certain number of mistakes in the surgeon's list of laparotomies. These mistakes must be regarded as far less serious than deferring operations for appendicitis till the diagnosis is invariably placed beyond doubt. In the author's cases the local signs conformed in a remarkable degree to the well recognized clinical picture of appendicitis; there was marked tenderness with rigidity at McBurney's point, and sudden release of pressure on the abdomen provoked lively pain. But, he admits, there were certain features of the general symptomatology in the first case which should have made him give pause. The patient, an unmarried woman of 21, complained of general lassitude, headache, and excessive perspiration. Her temperature was high from the outset (102.2°). The author subsequently remembered that he had never seen a patient suffering from acute appendicitis complain of headache and excessive perspiration, and he considers a high temperature early in the disease as a rare concomitant of acute appendicitis. He also refers to the simulation of acute appendicitis by encephalitis, a case in point being recently recorded by Seidel (*Munch. med. Woch.*, No. 7, 1921, p. 219).

511. Vaccine Therapy of Gonorrhoea.

HERMANS and VAN DEN BRANDEN (*Le Scalpel*, January 8th, 1921), after discussing the various vaccines (English, French, Italian, German, and Belgian) used in the treatment of gonorrhoea and its complications, conclude that this method of treatment is still in its infancy. It is true that in some of the complications of gonorrhoea, especially as regards epididymitis, excellent results have been obtained, but the chief enemy, the gonococcus, in its site of election, the urethral mucosa, too often escapes. Perhaps one reason is that the organism exists so superficially and is not sufficiently in contact with the blood stream, so that mechanical means of disinfection are always necessary adjuncts in treating simple gonorrhoea. On the other hand, when complications arise, vaccine therapy is the best mode of treatment. By this means many a case of epididymitis can be shortened and the secondary results prevented.

512. Acriflavine Irrigation in Gonorrhoea.

MANN (*Med. Record*, January 22nd, 1921) urges acriflavine irrigation in the treatment of gonorrhoea, the dyestuff being highly gonococcal and penetrating to the muscular layers of the urethra. A solution 1 in 4,000 is bland and non-irritating, and even when the urethritis is severe its use causes no pain or discomfort. Two ounces of a stock solution 1 in 500, containing a drachm of sodium chloride to each two ounces, diluted up to one pint with water at body temperature, yields a 1 in 4,000 solution of acriflavine in a physiological saline solution, and this should be used once a day, retaining the solution in the anterior urethra for ten minutes at the end of each irrigation. This, in conjunction with drinking ten to twelve glasses of water daily, constitutes the entire treatment. If the second urine becomes cloudy, indicating posterior involvement, intravesical lavage is used, unless the symptoms are hyperaesthetic, in which case anterior irrigations alone are used, until the severe symptoms abate, prior to instituting the intravesical irrigation. Results, which were controlled by cultures after provocative injection and massage, were more than ordinarily satisfactory.

513. Urinary Antiseptics.

DAVIS (*Amer. Journ. Med. Sciences*, February, 1921) summarizes the results of an investigation of the antiseptic properties and the renal excretion of 204 aniline dyes. There is no drug which is ideal for internal urinary antiseptics, but of the 204 aniline dyes investigated 61 possessed antiseptic properties in agar, and 28 of these were efficient when added to voided urine. Forty-four dyes showed a selective action against various organisms, the colon

bacillus always being more resistant than the *Staphylococci*, and only 24 inhibited the colon bacillus in urine in a dilution of 1 in 1,000. Antiseptic action is shown in higher dilution in alkaline than in acid urine, so that these dyes are more efficient in urine of a reaction which renders urotropin inert. Fifteen of the dyes were antiseptic in urine, excreted by the kidneys, and relatively non-toxic, but with only two of these (proflavine and acriflavine) did excretion of antiseptic urine follow intravenous administration. Dyes of the triphenylmethane, xanthone, acridin, and azin groups afford most promise of value, and these experiments give reasonable expectation that a dye clinically suited as an internal urinary antiseptic may be discovered or synthesized.

514. Ocular Manifestations of Epidemic Encephalitis.

HOLDEN (*Arch. of Ophthalmology*, March, 1921) has collected the eye symptoms noted in 100 consecutive cases of epidemic encephalitis at the Mount Sinai Hospital in New York. He tabulates his results as follows: (a) *Optic nerve symptoms*. Blurred optic discs in four cases; true papilloedema in one case. (b) *Oculo-motor and abducens nerve symptoms*. Ptosis: both eyes, forty-five cases; one-sided, eleven cases; total fifty-six cases. Extrinsic muscles of the eyeball: paralysis of both external recti, seventeen cases; paralysis of right external rectus, fourteen cases; paralysis of left external rectus, thirteen cases; total forty-four cases. Paralysis of both superior recti, one case; paralysis of both internal recti, four cases; paralysis of one internal rectus, one case; paralysis of both internal and external recti, two cases; total third nerve paralysis, one case; paralysis of conjugate dextroversion of both eyes, two cases; in all, weakness of oculo-motor muscles which would give rise to diplopia was present in fifty-five cases. Nystagmus was present in thirty-two cases. In regard to the condition of the pupils, there was an irregularity in fifteen cases and inequality in twenty cases; sluggishness or absence of the light reflex in thirty-five cases, in thirteen of which the convergence reflex was also sluggish. Irregularity and inequality of the pupils, not associated with sluggishness, was noticed in seven cases. There was weakness of accommodation in both eyes in one case. (c) *Facial nerve symptoms*. There was weakness, chiefly of the lower face and rarely leading to lagophthalmos, of both sides in twenty-four cases, and of one side in forty-nine cases, a total of seventy-three cases. It will be seen that the results are very closely similar to those reported by other observers. The total brings out the great rarity of fundus lesions in cases of epidemic encephalitis.

515. Treatment of Ozaena.

BRUZZI (*Arch. ital. di otol., rinol., y laringol.*, Fasc. v and vi, 1920) states that the factor in ozaena is due to the decomposition of protein bodies by means of bacterial tryptic ferments with formation of mercaptan and other sulphur compounds, and that the Perez bacillus, which is supposed to be the cause of ozaena, plays the principal part in this decomposition. In the nasal cavities there is normally a rich bacterial flora, consisting, among other germs, of glycolytic bacteria, so called owing to their power to ferment sugar. The object of the recently introduced glucose treatment of ozaena is to increase the activity of these micro-organisms in the fermentation of carbohydrates, to the detriment of the Perez bacillus. Moreover, tryptic ferments require an alkaline medium to act on protein substances, whereas the fermentation of sugars is accompanied by the formation of acid, whereby the proteolytic activity of the Perez bacillus is inhibited and the organism itself destroyed. The treatment consists in first removing the crusts by irrigation with an alkaline solution or spray and then applying a solution of glucose or honey on swabs three or four times a day to all parts of the nasal cavity. In 22 cases so treated by Bruzzi very satisfactory results were obtained. In 10 patients glucose was used and in 12 honey, the results being equally good in both cases. The duration of the treatment ranged from fifteen to thirty days.

516. Suction in Oto-laryngology.

WAGERS (*Therapeutic Gazette*, February 15th, 1921) points out the value and technique of the application of suction in the local treatment of suppurative inflammation involving the ear and nasal accessory sinuses as a means of obtaining cleanliness of the part treated, and, by producing local hyperaemia, of promoting healthy tissue reaction. Three types of apparatus are described—an electrical suction pump, the Brawley water suction pump, and an ordinary rubber bulb. The method is most often useful in the diagnosis and treatment of nasal accessory sinus disease,

and certain anatomical and physical points which have to be borne in mind for its successful accomplishment are mentioned. For the removal of blood from the throat during operation suction is most useful, providing a clear field of view and preventing the aspiration of blood and secretions, thereby minimizing the risk of pneumonias and lung abscesses. Although a certain number of cases will clear up in a few days after treatment by suction alone, the method cannot take the place of surgery where needed, but it assists in thoroughly removing purulent secretions, and in carrying away bacteria and their products from the involved area. It is equally applicable in chronic otitis media as in the acute condition, care being taken not to exercise too great a negative pressure, and in the post-operative treatment of suppurating mastoids it may be employed to remove all pus from the wound.

OBSTETRICS AND GYNAECOLOGY.

517. Persistent Vomiting during Pregnancy.

VAUDESEAL and HEUYER (*La Gynéc.*, January, 1921) remark that in the exceptional cases in which vomiting continues after the fourth month of pregnancy search should be made for an etiological factor other than a pregnancy toxæmia. As an illustration they relate the case of a primipara, aged 20, in whom emesis persisted and became increasingly severe from the fourth to the sixth month. In spite of treatment by strict dieting, together with subcutaneous and rectal injections of "adrenalized" serum, vomiting continued to occur almost hourly. The findings at laparotomy were normal, and the injection of serum from a healthy pregnant woman failed to control the vomiting. A few days after induction of abortion, inco-ordination of speech and of movement was noticed, together with nystagmus; lumbar puncture gave a clear fluid exhibiting hyperalbuminosis, but no cytological reaction. The patient succumbed, in a state of coma, shortly after an exploratory trephining had been performed. At autopsy there was found a cerebellar tuberculoma (the size of a nut) in process of caseation.

518. Indirect Expulsion of the Placenta.

BAER (*Journ. Amer. Med. Assoc.*, February 26th, 1921) considers that any method of ending the third stage of labour which does away with handling the uterus is desirable, and he describes an indirect method by utilizing the full power of the abdominal muscles to drive the uterus down against the separated placenta and so expel it. After a waiting period averaging half an hour, with the uterus in mid line, and while at the height of a contraction, the abdominal wall is grasped by one or two hands crosswise above the umbilicus, the fingers on one side beyond the rectus and the thumbs on the opposite side also beyond the rectus. The recti are then pulled together and firmly held, so that all the slack in the relaxed overstretched wall is taken up. The patient is now urged to bear down, her successful co-operation being felt by the contracting of the recti and their tendency to pull apart, which is prevented by the grip of the hands, so that the force is properly transmitted downwards against the uterus and the placenta is expelled as in spontaneous cases. The method operates only after separation has occurred, but its application is harmless if separation has not yet taken place. Of 277 cases in which the method was tried it was successful in 249 (90 per cent.).

519. Treatment of Fever following Abortion.

LÄTZKO (*Zentralbl. f. Gynäk.*, March 26th, 1921) returns to the discussion of the relative merits of immediate cruetting and of expectant treatment in cases of pyrexia following abortion. While admitting that expectant treatment may prolong the period of convalescence, he is convinced that as a result of active treatment the percentage mortality is increased. At the Bettina-Pavillon in Vienna *post-abortion* fever was treated actively from 1910 to 1914, expectantly from 1915 to 1920. During the former period the percentage mortality was 5 per cent. in cases with temperatures from 98.6° to 100.4°; 11 per cent. in cases with temperatures from 100.4° to 101.3°; and 14.8 per cent. in cases with temperatures above 101.3°; after the adoption of expectant methods the percentage mortality was reduced in each group, the figures being 3.6 per cent., 7.8 per cent., and 10 per cent. respectively. Special interest attaches to these statistics in that they relate to periods of five years, and that about 4,000 cases were recorded during each period. HALBAN (*Ibid.*), who in 1,595 cases of febrile

abortion, treated actively, had a mortality of 3.1 per cent., is not convinced of the superiority of expectant treatment, and criticizes the statistics which have been published. In particular, he points out that fatal cases are in the majority of instances (75 per cent. in his series) drawn from among those patients who on admission to hospital already have some severe extrauterine complication; the excessive mortality among such cases should be taken into account when comparing the comparative death rates associated with different modes of treatment.

520. Colostrorrhoea in Pregnancy.

DEL VECCHIO (*Il Policlinico*, Sez. Prat., February 21st, 1921) alludes to the case of galactorrhoea recently reported by Luzzatti (vide *Epitome*, February 26th. No. 278), and relates the case of a primipara, aged 22, who in the fifth month of pregnancy developed a profuse flow of colostrum from both breasts, followed by erosion of the nipples. In the seventh month of pregnancy the flow ceased without any appreciable cause. Pregnancy went on to term, and labour and the puerperium were physiological. Unlike Luzzatti's case, galactorrhoea did not occur after delivery, but the secretion of milk, which set in as usual on the third day, was quite normal.

521. Transvesical Operations for Vesico-vaginal Fistula.

MARION (*La Gynéc.*, December, 1920) related to the Société de Chirurgie the case of a woman who, in spite of five previous attempts at operative repair, had a large vesico-vaginal fistula, the cervix projecting within the vesical cavity. Operation by the transvesical route proved successful in this as well as in twelve other cases operated on by Marion. All those who contributed to the subsequent discussion were agreed as to the usefulness of the transvesical approach, especially in the case of fistulae situated relatively high in the vagina.

PATHOLOGY.

522. Prevention of Anaphylactic Shock.

BRODIN and RICHEL (*C. R. Soc. Biologie*, February 12th, 1921), in comparing the blood changes in anaphylactic shock with those found in what has been called "peptone shock," find many points of similarity, such as fall of arterial pressure, leucopenia, hyperviscosity, decrease of coagulability, and others, though there are certain differences. Knowing that a previous injection of peptone immunizes against a subsequent injection, they sought to find if it was possible to produce a cross immunity and thus prevent anaphylactic accidents. Six dogs were therefore given an intravenous injection of 50 to 100 c.cm. of horse serum, and after one or two months 10 to 15 c.cm. of peptone per kilogram of body weight were injected rapidly into the veins, and an hour afterwards they were tested with 50 to 100 c.cm. of horse serum. The peptone injection was always well tolerated. The testing dose of horse serum was followed by only very slight symptoms, whilst of the control animals, not treated with peptone, 4 out of 7 showed severe or fatal crises. Thus the injection of peptone may attenuate considerably the danger of anaphylactic shock.

523. The Pathology of War Oedema.

WELTMANN (*Wien. Arch. f. inn. Med.*, December 15th, 1920) records three cases of war oedema in which atrophy of the pancreas was found at the autopsy. He draws attention to certain resemblances between war oedema and diabetes mellitus—namely, polyuria, hyperglycaemia, the increase of acetone bodies in the blood, increased excretion of creatin, uric acid, ammonia, and amino-acids, the deficiency of glycogen in the liver, the readiness with which the oedema can be produced by sodium bicarbonate, and finally the coma preceding death. Weltmann considers that the oedema disease is closely allied to the miasmatic condition accompanied by dropsy which occurs in children as the result of alimentary disturbance. He regards the atrophy of the pancreas in his cases as an expression of a constitutional deficiency.

524. Picrocarmine Staining of Sections.

JENSLIN (*C. R. Soc. Biologie*, February 12th, 1921). gives a method of preparing this old stain which is applicable to paraffin and celloidin sections. Picrocarmine staining was difficult, even with frozen sections, but when it was

brought off successfully it was a beautiful method. Jensen, who has tried various ways of getting good results, recommends the following:—First solution: dissolve 1 gram of carmine and 0.1 gram of magnesium oxide in 50 c.cm. of distilled water, boil for five minutes, filter when cold, and add 0.5 c.cm. of carbolic acid. Second solution: Mix 0.5 gram of picric acid and 0.5 gram magnesium oxide in 50 c.cm. of distilled water, boil for five minutes, and filter when cold. Mix these two solutions and add slowly, with shaking, 10 c.cm. of 1 per cent. solution of picric acid in distilled water. The clear resultant liquid keeps indefinitely. It stains the nuclei intensely with paraffin sections, especially after fixation in sublimate or alcohol, but it also acts well after formalin fixation. It may be used in conjunction with Claudius's modification of Gram's stain. After removal of the paraffin and washing in alcohol the sections are stained for two or three minutes in 1 per cent. aqueous solution of methyl violet, and, after washing in water, stained with the picrocarmine solution for three to five minutes; the stain is poured off and the sections dried with filter paper, after which they are differentiated with aniline oil containing a little picric acid until they show a rose colour. The bacteria in the sections are stained blue-black, the nuclei red, the protoplasm orange, muscle and red corpuscles yellow, and the connective tissue rose.

525. Bence-Jones Proteinuria.

WALTERS (*Journ. Amer. Med. Assoc.*, March 5th, 1921) has had the opportunity of studying three cases of Bence-Jones proteinuria. The first patient had an obscure complaint suggestive of duodenal ulcer, but there was no demonstrable lesion of any of the bones, either by physical examination or by roentgenographic studies; apart from the characteristic protein in the urine, indeed, there was no abnormality found. The second case was one of generalized carcinomatosis with bone involvement, and the third case was one of multiple myeloma, in which the peculiar protein is generally found. The author found that the quantity of Bence-Jones protein excreted is independent of the protein intake, as there was an approximately constant excretion for three-hour periods irrespective of changes in diet, and that the amount excreted during night-time when no food is taken is only slightly less than the amount excreted during the day. There was no constant relationship between the quantity of Bence-Jones protein and the total urinary nitrogen.

526. Tumours of the Auditory Nerve.

ACCORDING to FUMAROLA (*Il Policlinico*, Sez. Med., February 1st, 1921), who records two illustrative cases, it is not justifiable in the present state of our knowledge to make any other diagnosis than that of a tumour of the ponto-cerebellar angle without determining whether it is primary or secondary. Once the diagnosis of a tumour in this situation is made, surgical intervention is called for, even when the signs point to a secondary growth, as it may happen, as in one of Fumarola's cases, that the tumour is really primary and therefore should be removed. Fumarola also draws attention to the medico-legal importance of the close relation between trauma and the development of endocranial tumours. In one of his cases the symptoms developed three weeks after the patient had been wounded on the head and elsewhere by the explosion of a bomb, so that the disease might properly be regarded as a war injury.

527. The Metabolism in Vascular Hypertonus.

HITZENBERGER and RICHTER-QUILTNER (*Wien. Arch. f. inn. Med.*, February 15th, 1921) during the last few years have made a systematic examination of the blood sugar in a number of cases of hypertonus. The cases were divided into three groups: (1) Primary hypertonus, (2) secondary hypertonus due to chronic glomerular nephritis, (3) hypertonus associated with diabetes mellitus. They found that hyperglycaemia was a regular occurrence both in primary and secondary hypertonus. This form of hyperglycaemia differed from that met with in diabetes mellitus chiefly in being independent of an alimentary factor. It was therefore not due to a disturbance of sugar assimilation but to a persistent overproduction of sugar. In cases in which vascular hypertonus was associated with diabetes mellitus hyperglycaemia was out of all proportion to the sugar excreted in the urine. In vascular hypertonus there was frequently also an excess of uric acid in the blood. The writers think that the syndrome of hypertonus, hyperglycaemia, and hyperuricaemia may depend on an increase of secretion of adrenaline.

EPITOME OF CURRENT MEDICAL LITERATURE.

MEDICINE.

528. Acute Leukaemia.

ACCORDING to SABRAZÈS (*Gaz. hebdomadaire des Sci. Méd. de Bordeaux*, March 6th and 13th, 1921), acute leukaemia, though a fairly rare disease, occurs at all ages, with a special predilection for childhood and adolescence. It is most frequent in the male sex. Various pathological conditions, especially infectious, figure in the history, such as rickets, chronic enteritis, haemorrhages, septicæmia, puerperal infection, typhoid fever, scarlatina, tonsillitis, tuberculous, malaria, syphilis, and influenza. In several cases traumatism has been incriminated. In the splenomegaly, enlargement of the lymphatic glands, and pain on pressure on the sternum, the disease may resemble ordinary chronic leukaemia, but the course is more rapid, the tendency to haemorrhages often more marked, the fever high, and the asthenia profound. The bad state of the mouth and gums, which bleed on the slightest provocation, should be a warning sign. Acute leukaemia may simulate septicaemia, typhoid fever, dysentery, acute or subacute pulmonary tuberculosis, purpura haemorrhagica, scurvy, acute rheumatism, or acute nephritis. Sometimes the disease is complicated from the first by haemorrhagic and gangrenous processes in the pharynx, buccal mucosa, or gums, so as to resemble hypertoxic diphtheria, or noma. Lastly, the disease may be mistaken for acute meningitis, because of meningeal haemorrhage, or for urticaria pigmentosa, because of leukaemic lesions of the skin. All modes of treatment have hitherto proved ineffectual. The measures applicable to chronic leukaemia, such as radium, x rays, arsenobenzol, are held to be contraindicated in acute leukaemia.

529. Hirsutism and Diabetes Mellitus.

WEIL and PLICHET (*Bull. et Mém. Soc. Méd. des Hôp. de Paris*, March 10th, 1921) have collected three examples of diabetes mellitus associated with hirsutism in women, including a personal case. In Guemes's case the glycosuria was slight and transient, and in Tuffier's case abundant and persistent, while in their own case there was a true diabetes accompanied by polydipsia, polyphagia, and loss of flesh, complicated by fatal pulmonary tuberculosis. Weil and Plichet maintain that the association of diabetes with hirsutism is not a mere coincidence, as Laignel-Lavastine, in examination of two cases of hirsutism without glycosuria, was able to detect latent disturbance of carbohydrate metabolism, shown by the appearance of glycosuria on subcutaneous injection of suprarenal extract, thyroid extract, or pituitary extract (extract of the whole gland or of the posterior lobe only), whereas in a control glycosuria was produced only by injection of the posterior lobe of the hypophysis. Hirsutism, which is always caused by ovarian lesions and often by lesions of the suprarenals, is accompanied by other endocrine disturbances, such as obesity, hypercholesterinaemia, and glycosuria amounting to diabetes. This form of diabetes, whether slight, moderate, or severe, is similar to that found in other diseases of the endocrine glands, such as acromegaly or Graves's disease, in which involvement of the hypophysis or thyroid affects the hepatico-pancreatic system, which controls the metabolism of starch.

530. Diagnosis of Neuromyositis.

ACCORDING to HÖGLER (*Wiener Arch. f. inn. Med.*, December 15th, 1920), who records an illustrative case in a woman aged 50, the following conditions must be excluded in the diagnosis of neuromyositis: (1) Trichinosis. In typical cases the masseters, temporal muscles and laryngeal musculature are chiefly affected. Severe gastro-intestinal disturbances are also invariably present. Persistent eosinophilia is generally regarded as characteristic of trichinosis, but transient eosinophilia, which may range from 7 to 16 per cent., may occur in neuromyositis. (2) Polymyositis. In this condition inflammatory swelling of the muscles, oedema of the skin, and violent muscular pains are the principal symptoms. Neuritic symptoms are absent. (3) Polyneuritis, especially alcoholic neuritis. In most of these cases the neuritis affects definite areas and leads to neuritic atrophy. Histological examination in polyneuritis shows simple muscular atrophy, apart from the nerve changes. (4) Typical progressive neural muscular atrophy.

This disease usually begins in the small muscles of the foot, more rarely in those of the hand. Usually it gives rise later to muscular atrophies and contractures. Unlike typical polyneuritis, it is almost always hereditary and familial. The other myopathies, such as myositis ossificans and progressive and regressive interstitial calcinosis, are not likely to cause difficulty, and can be distinguished by x -ray examination.

531. Thyroid Extract in Köhler's Disease.

ABRAHAMSEN (*Hospitalstidende*, February 9th, 1921) points out that opinions are still divided as to the etiology of that disease of the scaphoid bone which is associated with Köhler's name. It may be due to (1) trauma—that is, fracture of a healthy bone; (2) fracture of a dystrophic bone; or (3) delayed ossification—that is, a dystrophic condition only. The author inclines to the third hypothesis, having found the condition react with remarkable promptness to treatment with thyroid extract. Before this treatment was instituted in the case of a lad, aged 7, the x rays showed hardly a sign of ossification in the scaphoid bone on the right side, whereas on the left side the x -ray picture was normal. For the next two to three months he was given 15 cg. of dried extract of thyroid daily. At the end of this period the x -ray picture had changed completely; while on the first occasion it had shown almost a total absence of ossification, it now showed a well-developed centre of ossification about 7 mm. long. Its shape was irregular, and the outline of the bone corresponded closely to the characteristic features of Köhler's disease. As there was no history of trauma in this case, and as it was difficult to assume the existence of a fracture in the soft and cartilaginous scaphoid, the condition should be regarded as one of delayed ossification.

532. War Injuries and Tuberculosis.

ACCORDING to AUSTGEN (*Zeit. f. Tuberk.*, February, 1921), writers are generally agreed as to the following points: (1) A trauma affecting the lung is a predisposing cause of pulmonary tuberculosis; (2) a trauma of this kind may rouse an old tuberculous focus in the lungs into fresh activity; (3) wounds of the lungs are very rarely followed by tuberculosis of the injured part. Austgen has recently observed four cases of tuberculosis following gas poisoning, two following a fall on the chest, and thirteen following concussion and other injuries to the chest. Of the four cases of gas poisoning, two were in the first stage and two in the second stage of the disease. Of the two following a fall on the chest, one was in the first and the other in the second stage. Of the thirteen cases of concussion, five were in the first, four in the second, and two in the third. Fifty-eight cases of war injuries were observed in which the lungs and chest were not wounded. Three cases showed no signs of tuberculosis; while of the remaining fifty-five, twenty-three were in the first stage, eleven in the second, and twenty-one in the third. In only three of the fifty-five cases did the pulmonary tuberculosis develop immediately or within six months after the trauma, and even in these cases only an indirect connexion could be found between the war injury and the pulmonary tuberculosis, the origin of which was due to diminished resistance to the tubercle bacillus resulting from loss of blood.

533. Psoriasis in South Africa.

PIPPER (*South African Medical Record*, March, 1921) addressed a series of twenty-eight questions to all medical practitioners in the Union, and from the answers he concludes (1) that psoriasis is rare at an altitude of more than 4,000 ft.; (2) that a high percentage of cases are complicated by asthma; (3) that persons emigrating to South Africa have nothing to hope for in the way of benefit. Psoriasis is exceptionally rare amongst the natives of South Africa.

534. Prurigo Cured by Auto-haemotherapy.

NICOLAS, GATÉ, and DUPASQUIER (*Ann. de Derm. et de Syph.*, No. 3, 1921) report two cases of severe prurigo cured by auto-haemotherapy. The first case was that of a tabetic who had had injections of novarsenobillon in March, 1920. In June he began to have severe prurigo, and every form of dietetic and medical treatment failed to give

relief. In September 10 c.c.m. of blood were withdrawn from a vein and injected into the muscles of the buttock, and this was repeated on four occasions at intervals of four days with complete success. The injections of nov-arsenobillon were resumed at a later date without any return of the prurigo. The second case, an example of severe prurigo ferox, was cured after ten injections of blood in the same way after other remedies had failed. In this case syphilis was not present.

535. The Peculiar Odour of Jaundiced Patients.

PICHLER (*Zentralbl. f. inn. Med.*, February 19th, 1921) alludes to the statement of Eppinger that in a number of cases of jaundice there is a peculiar odour of the breath reminiscent of indole, which has led him to a correct diagnosis of icterus gravis. Pichler himself has noticed a similar odour about twenty times in 100 cases of catarrhal jaundice and about 90 cases of cirrhosis of the liver. As a rule the odour was strongest when the jaundice was pronounced, being often absent at the onset and first appearing when the jaundice became deep. In fatal cases the odour lasted until death. *Post mortem* it was no longer present, nor could it be detected in the urine, in spite of repeated examinations. It gradually disappeared in cases which recovered. Pichler never noticed the odour in dozens of cases of jaundice due to gall stones or carcinoma of the liver and pancreas with obstruction of the bile duct. He has, however, found it in a few cases of cancer of the stomach, even when there was no jaundice and when no sign of liver disease could be detected during life or at the autopsy.

536. The Electro-cardiograph.

PACE (*Rif. Med.*, February 26th, 1921) says the chief value of the electro-cardiograph from the clinical point of view is in the unravelling of the various forms of cardiac arrhythmia. Extra-systoles can easily be recognized with the electro-cardiograph and their origin ascertained. Tachycardia can also by this means be resolved into its various types. Disturbances in conductivity are especially suitable for examination in this way, and it is only by the electro-cardiograph that what is called the pulsus irregularis perpetuus can be detected. Lastly, certain alterations in the ventricular wave which occur in cases of cardiac muscular insufficiency—for example, in nephritis—can be most usefully examined in this way.

SURGERY.

537. Cutaneous Cancer of the Bridge of the Nose.

MOURE (*Rev. de lar., d'otol., et de rhinol.*, February 15th, 1921) states that this variety of cancer of the face occurs in persons aged from 40 to 60, and is apparently more frequent in women. It may appear without any obvious cause or develop on a congenital naevus. It may be situated at the root of the nose, but it is most frequent on the middle third. Its position may be exactly in the middle line, but it may also be lateral. It assumes the vegetative or ulcerative form, but these two forms are not necessarily associated with distinct histological lesions. Dorso-nasal cancer usually begins as a small elevation, which increases in size very slowly, and then, either spontaneously or as the result of a slight trauma, an ulcer forms which bleeds at the slightest contact. As the growth progresses it extends not only superficially but also in depth. Invasion of the lymph glands is usually slight and occurs late. The diagnosis is generally easy. Although at first it may be mistaken for an unimportant lesion, as soon as it becomes ulcerated the tumour becomes covered with a dark crust and the resulting appearance is characteristic. Treatment consists in early and free extirpation of the growth.

538. Treatment of Surgical Tuberculosis with Partial Antigens.

LANDAUER (*Zeit. f. Tuberk.*, February, 1921) treated with partial antigens eight cases of surgical tuberculosis, including three of osteo-articular disease, four of glandular tuberculosis, and one of tuberculosis of the soft parts. His conclusions were as follows: While no harm resulted from the treatment, there was no real benefit. In many cases partial antigen treatment might be of use if associated with other therapeutical measures. The results, however, were not better than those derived from Koch's old tuberculin, which Landauer had been using for years in the treatment of surgical tuberculosis and had found more pleasant for the patient and easier to manipulate than partial antigens.

539. Clinical Examination of the Duodenum.

PARTURIER and VASSELLE (*Bull. et Mém. Soc. Méd. des Hôp. de Paris*, March 10th, 1921). As the result of sixty radiological examinations, have been able to distinguish a high and a low position of the duodenum. In 37 per cent. of the cases the duodenum was in the high position, in 53 per cent. in the low position, and in 10 per cent. in an intermediate position. A duodenum in the high position is usually found in thick-set, muscular persons of low or medium height with a short thorax wide at the base. A duodenum in the low position is to be suspected under two conditions: (1) In persons with a long narrow thorax; (2) in cases of abdominal ptosis. These differences of position, which are well marked in the erect posture, are considerably diminished in the dorsal decubitus in which the abdominal contents are driven back against the thorax. When the subject is in the dorsal decubitus, in 85 per cent. of the cases the duodenum corresponds to the anatomical description, the second part being comprised between an upper plane passing along the eighth rib in front and part of the first lumbar vertebra behind, and a lower plane passing through the umbilicus or a little below and the lower half of the fourth lumbar vertebra.

540. Hydrocoele in Children.

QUACKENBOS (*Med. Record*, March 5th, 1921) regards hydrocoele occurring in children as symptomatic of a localized subacute or chronic infective process, the focal lesion in the majority of cases being in the mesentery of the caput or its vermiform appendix. Tubercle or rheumatism may be the cause of a localized peritonitis, and cure of the funicular variety of hydrocoele has followed enucleation of the faucial tonsils. Operation by excision of the distended peritoneal process is not indicated in all cases, since inspection of the throat and the presence of enlarged tonsillar lymph nodes or mesenteric glands may point to the course of treatment necessary. A pad and bandage with local applications of iodine sometimes cure. Circumcision or meotomy may be needed, union of the cut areas in the latter operation being best prevented by the introduction of a suture of double horsehair through the base of the incision with the knot located in the wound. The tightly-tied suture cuts out in a few days and is more efficacious than the lubricated plug.

541. Anterior Dislocation of the Os Magnum.

ACCORDING TO DOUARRE and MOUCHET (*Bull. et Mém. Soc. de Chir.*, February 15th, 1921), who record an illustrative case, anterior dislocation of the os magnum is extremely rare, only seven cases having been previously recorded—namely, by Gouilloud and Arélin in 1908, Mouchet and Vennin in 1913, Mayersbach in 1913, Tanton in 1915, Mouchet in 1918 (two cases), and Cotte in 1919. In each of the previous cases the dislocation was associated with one of the two following conditions: (1) Most frequently a fracture, either of the scaphoid (Gouilloud and Arélin, Mouchet and Vennin, Tanton) or of the lower end of the humerus with or without involvement of the ulna (Mouchet), or of the os magnum itself (Mouchet and Vennin). (2) Pronounced displacement of the semilunar to one side. In the present case the dislocation was not accompanied by any fracture, and the semilunar and pyramidal bones remained in their position below the radius. The dislocation was reduced without any difficulty under a general anaesthetic, whereas in Cotte's case after two unsuccessful attempts at reduction had been made under an anaesthetic and the semilunar bone had been removed the carpus was resected.

542. Radium in Sarcoma and Carcinoma of Bone.

NELLI, JUNR. (*Amer. Journ. of Surg.*, February, 1921), after testing the efficacy of radium in the treatment of sarcoma of bone, finds that the disease is sometimes destroyed with the formation of new healthy callus. The number of cases treated is at present too small for the citation of percentages. Three methods were tried: (1) Permanently burying minute glass capillary tubes (containing from 1 to 3 millicuries) directly into the disease; (2) massive treatments from the surface at from 1 in. to 4 in. distance with from 1 to 4 grams of radium; and (3) laying bare the diseased tissue and inserting a large amount of radium into the tumour while the patient is under anaesthesia. The first appears to be the most effective, and in some instances all three methods were combined. The most striking result is complete or partial relief of pain, and this is followed by marked decrease in swelling, increased function, general improvement in health, and redeposition of new bone taking place in from two to five weeks.

543. Treatment of Typhoid Spine by Vaccines.

DUFOUR, DEBRAY, and GAYARD (*Bull. et Mém. Soc. Méd. des Hôp. de Paris*, March 17th, 1921) record the case of a woman, aged 42, with signs of typhoid spondylitis localized in the second lumbar vertebra. As other treatment was unsuccessful, she was given five injections of Vincent's T.A.B. vaccine, the first injection consisting of $\frac{1}{2}$ c.cm., the second (four days later) of 1 c.cm., the third (nine days later) of $1\frac{1}{2}$ c.cm., and the fourth and fifth of $1\frac{1}{2}$ c.cm., with ten days' interval between each. After the first injection the temperature fell from 102.2 to 100.4 F., and after the second to 98.6 F. The third injection was followed by a transient rise of temperature to 101.2. The pain disappeared very rapidly, and the last three injections were merely given to render the cure more certain. Dufour had previously treated three other cases of typhoid spine successfully by T.A.B. vaccine.

544. Delayed Union in Fractures.

SEGRE (*Riv. Osped.*, January 31st, 1921) reports five cases of delayed union in fractures where consolidation was soon induced by means of injections of 1 per cent. solution of osmic acid. From 1 to 5 c.cm. was injected at the site of fracture and the injection repeated in three or four days' time. The best results were obtained by giving the smaller injections—that is, 1 c.cm.—at more frequent intervals. Very little local pain followed their administration.

545. Eversion of the Mucosa of the Laryngeal Ventricle.

TAPIA (*Arch. de Med. Cirug. y Especialidad*, March 1st, 1921), in a communication to the Real Academia de Medicina, described a case of this rare condition, the existence of which (in consequence of the close connexions which, as a rule, bind the mucous lining of the second portion of the larynx to the subjacent tissues) has been denied. The removal under local anaesthesia of a polypus situated on the anterior third of the right vocal cord was rendered difficult by the co-existence of a loose area of hypertrophied and varicose mucosa which had become everted or prolapsed from its original situation within the laryngeal ventricle and which almost completely covered the right vocal cord. Two days after the extirpation of the polypus the oedematous everted area of mucosa became incarcerated in the ventricular orifice, leading to much dyspnoea and considerable interference with phonation. The tumour became spontaneously reduced during a fit of coughing which followed an intralaryngeal manipulation; three days later function had become restored and the appearances were normal.

546. Acute Purulent Otitis Media in Children.

CALLISON (*Med. Record*, March 5th, 1921) discusses acute otitis media in children, and urges more careful inspection of ears and more persistent treatment of those infected. Practically always secondary to a nasopharyngitis, the *Streptococcus haemolyticus*, and the *Pneumococcus capsulatus*, No. 4, are the principal infecting organisms. In the early stages direct inspection of the tympanic membrane is the only means of diagnosis, and in a routine examination such inspection should rank next in importance to abdominal inspection and before examination of the chest. Redness and bulging of the drum may be the only early symptoms, the presence of pain and fever being not so constant. In rare cases, when the Eustachian tube remains patent, there may be no bulging of the membrane, making a certain diagnosis very difficult, and only finally established when discharge occurs from the ear. As a prophylactic measure, the author recommends that adenoids should be removed from all children with any tendency to mouth-breathing, or subject to recurrent colds. Once a purulent condition is established a wide opening in the membrane should be made under general anaesthesia. By a double incision a horseshoe-shaped flap of the drum, supported on the handle of the malleus, is obtained, which is the form most likely to remain open while conserving the hearing and preventing mastoid infection, and such an opening must be kept open until a cure is effected. Post-operative measures consist in irrigating the nasopharynx with some antiseptic solution, and if necessary swabbing the throat. The external auditory canal should be irrigated with boric acid solution, dried with cotton-wool, and a few drops of antiseptic solution instilled. If, after removal of adenoids, the discharge threatens to become chronic, a mastoid operation should be performed even in the absence of positive symptoms of mastoid involvement, a healed mastoid with good hearing being preferable to a chronic running ear with loss of hearing.

OBSTETRICS AND GYNAECOLOGY.**547. Etiology of Repeated Abortions.**

PERAZZI (*Annali di Ostetrica e Ginecologia*, January, 1921), basing his work on that of Abderhalden with regard to the reaction of the body to the entrance within the circulation of foreign proteins or of abnormal proteins derived from local abnormalities in the organs of the body itself, has endeavoured to throw light on the causation, which has hitherto been obscure, of cases of repeated abortions in non-syphilitic women. Surmising that functional alterations in the organs (especially those of internal secretion) of such women might be followed by a production within the blood of ferments capable of modifying the proteins derived from the particular organ which was concerned, Perazzi tested in a dialyzer the action which was exercised (1) by the serum of healthy non-pregnant women; (2) by that of healthy pregnant subjects; (3) by that of women who, in spite of the absence of a positive Wassermann reaction or of a history of syphilis, had undergone repeated abortions—on tissue derived from a series of organs removed from sheep. With the serums of eight healthy non-pregnant women digestion was absent, save that one sample—derived from the subject of a thyroid hyperplasia—there was some digestion of thyroid substance. With the serums of 20 healthy gravid subjects the reaction was markedly positive for chorion in all, and feebly positive for decidua in 11, ovary in 13, corpus luteum in 9, thyroid in 7, and breast in 11. With the serums of 23 women who had had repeated abortions of obscure cause, the reaction was markedly positive for chorion in 25, for ovary in 7, for corpus luteum in 9, for thyroid in 5, for breast in 7, and feebly positive for decidua in 8, for ovary in 10, for corpus luteum in 3, for breast in 6, for thyroid in 1, for suprarenal in 5, for hypophysis in 1, for thymus or parathyroid in none. Without venturing from these results to express an opinion on the influence of the various internal secretions on the fixation of the ovum, the author claims to have demonstrated, in the serum of the subjects of repeated abortions, deviations from the normal with regard to specific proteolytic ferments.

548. The Source of the Toxin of Eclampsia.

EXAMINING the views which have been put forward from time with regard to the origin of the toxin of eclampsia, GESSNER (*Zentralbl. f. Gynäk.*, April 2nd, 1921) points out that when by the demonstration of eclampsia in cases of hydatidiform mole (where there is no foetus) the theory of foetal origin had been disproved, an origin of the toxin from the placenta was claimed first by Veit and later by Hofbauer. Veit explained eclampsia as due to poisoning with syncytio-toxin, for which an antibody had not been manufactured by the body cells with sufficient rapidity. This view was abandoned when investigations failed to show the existence in the placenta of an antigen. Hofbauer, although he has abandoned the view which regarded eclampsia as an anaphylactic reaction, still believes that it is due to a maternal intoxication with deleterious products derived from the placenta. Gessner believes that all theories of a placental origin of the eclamptic poison are untenable; his paper is mainly directed to a criticism of Hofbauer's contentions in the two following respects: first, Hofbauer states that the anatomical peculiarities of human placentation (and human placentation alone) are such as to allow processes of ebriation to be bathed in maternal blood, with consequent facilitation of the passage of ferments (and other bodies) from one into the other. So far Gessner is in agreement, but he points out that Hofbauer's statement that eclampsia, in correspondence with this biological peculiarity, is confined to the human species, is incorrect. Eclampsia also occurs in young cattle. The second objection put forward by Gessner is that in pregnancy with chronic nephritis repeated placental infarctions not infrequently occur, giving rise to favourable opportunities for entrance of placental substances into the circulation: in such circumstances, however, the eclamptic phenomena are excessively rare.

549. Peripheral Neuritis Occurring in Pregnancy.

FÖCKER (*Edin. Med. Journ.*, April, 1921) records a case of typical general peripheral neuritis occurring idiopathically and in definite relation to pregnancy, and not as a mere coincidence, representing a condition which is only an occasional accompaniment of pregnancy. All the usual causes of neuritis were excluded, and, apart from local pelvic paralyses due to mechanical effects or to inflammatory extension, such paralyses are the result of infection or are of toxic origin. In the case recorded septi-

infection was excluded, and clinically it was similar in type to alcoholic neuritis, the underlying condition being a degeneration of the affected nerves resulting from a circulating toxin. Hyperemesis and obstinate constipation, with loss of memory and at times delirium, occurring during the early months, are among the points of interest, and this association of hyperemesis and neuritis frequently occurs in severe cases. Treatment consists in active regulation of the bowels and improvement in the action of the kidneys, the prognosis being good unless the neuritis affects any nerves vital to life, when induction of premature labour may be needed, though delivery does not always mean a rapid amelioration of the condition. In this case the patient was delivered of a healthy child at full term, the various symptoms continuing through the pregnancy, and clearing up completely about four months later.

550. Intravenous Injections of Mercuric Chloride for Puerperal Fever.

COVA (*Annali di Ostetricia e Ginecologia*, January, 1921), during ten years' experience of intravenous injections of mercuric chloride for treatment of severe generalized puerperal infections, has come to the conclusion that it has at least as useful a place as that of vaccine therapy and colloidal injection: in common with these methods it is apt at times to prove quite ineffective, but in the author's hands it has proved in many cases to be of great value. The daily injections are given successively on six, seven, or eight days; the dose recommended is about 1 cc. at each injection. Cova is of the opinion that while sublimate injections are contraindicated in cases in which there are chronic renal lesions of long standing, or in which a nephritis has undergone an exacerbation during a recent pregnancy, nevertheless it is safe to give these injections in cases where the nephritis is recent and has originated as a concomitant of the puerperal infection. He has given six or more injections in 6 cases in which albuminuria (as shown by the history of the case and by the character of the urine) was attributable to a nephritis such as has just been described. The existence of nephritis was in itself a proof of the severe nature of the infection; nevertheless, 4 of the cases recovered completely. In one case two parts of albumin per thousand were present in the urine at the beginning of treatment; the albuminuria diminished steadily, and two days after the sixth injection had almost entirely disappeared; with the possible exception of a slight transitory increase of albuminuria occurring temporarily in one case, the mercuric chloride injections were never found to be followed by evidence of aggravation of renal impairment.

PATHOLOGY.

551. The Bactericidal Power of the Intestinal Mucosa.

SOTA (*la Pediatria*, February 1st, 1921) recalls the great difference in the bacterial flora in different parts of the intestinal tract. The comparative absence of bacteria in the stomach may be partly due to the action of the free acid, but the author believes that it is also due to some substance derived from the pavement epithelium of the mucosa. The varying distribution of bacteria in the gastro-intestinal canal may be partly due to mechanical, chemical, or biological causes, such as peristalsis, oxygen content, succus entericus, presence of other micro-organisms. But the author lays especial stress on the bactericidal power of the intestinal mucosa, and from a series of experiments he concludes that such a power does exist, and is due to a specific biological action of the epithelium of the mucosa. He found that when complete ischaemic necrosis of the mucosa was induced the bactericidal power was completely lost. This power varies in intensity in different parts of the intestine, and is most active during fasting. Besides acting on vegetative types, it also acts on spores.

552. Meningococcal Urthritis.

DUMONT and BARON (*Bull. et Mém. Soc. Méd. des Hôp. de Paris*, December 9th, 1920) record the case of a man, aged 40, admitted to hospital in a state of coma from severe cerebro-spinal meningitis: on the day before he had been quite well. Two days after admission, suppression of the urine having developed, the patient was found to be suffering from a purulent urethritis: three days later a unilateral orchitis was noticed, which, however, passed off. Blood culture was negative, but from the cerebro-spinal fluid, urethral pus, and nasopharyngeal secretion, a parameingococcus, whose nature was established both by culture and agglutination tests, was isolated.

553.

Pyelonephritis.

BUMPUS, JUNR. and MELISSER (*Arch. Int. Med.*, March 15th, 1921), working on the possibility that oral sepsis may be a focus of infection for bacteria having selective affinity for the urinary tract, studied a series of cases of pyelonephritis and dental sepsis, and, by intravenous injection of the bacteria into animals, endeavoured to ascertain whether any relationship exists between the two conditions. The six cases investigated showed undoubted clinical and cystoscopic evidence of pyelonephritis with varying degrees of cystitis, and streptococcal cultures from the teeth produced definite lesions in the kidneys of the rabbits, the selective affinity for the urinary tract being so marked that, although a mixed culture was injected into some of the animals, the streptococcus alone was recovered from the lesions. The kidneys of the rabbits always showed localized infections, but never a parenchymatous nephritis, the capsule stripping readily, necrotic areas surrounded by zones of congestion and haemorrhage being present in the medulla. These investigations appear to prove that pyelonephritis may often be due to focal infectious harbouring streptococci, which have a selective affinity for the urinary tract, and that the colon bacillus, though generally present, is of secondary importance as a causative agent.

554.

The Etiology of Calvé-Perthes's Disease.

WIDERÖE (*Zentralbl. f. Chir.*, February 5th, 1921) is of opinion that all cases of osteochondritis deformans juvenilis, or Calvé-Perthes's disease, are of traumatic origin. As the vessels are most numerous at the neck of the femur, a process of absorption only takes place in this situation, whereas the head of the femur, which receives much less blood supply, does not show absorption but necrosis. If a better circulation is established, secondary absorption takes place. Wideröe rejects as fantastic the suggestion that endocrine disturbance is responsible for the condition. He prefers the name "Malm coxae, Calvé-Perthes" (or Calvé-Legg-Perthes), as it does not imply any false ideas as to the nature of the disease. FROMME (*Ibid.*) holds that osteochondritis is simply a disturbance in the normal course of ossification of the epiphyses, for which various factors are responsible, rickets and slight trauma being the most frequent causes.

555.

The Colloidal Benzoin Reaction in the Cerebro-spinal Fluid.

DEHOT and CRAMPON (*Bull. et Mém. Soc. Méd. des Hôp. de Paris*, March 10th, 1921) examined the reaction of precipitation of a suspension of colloidal benzoin by the cerebro-spinal fluid, as introduced by Guillaum, Laroche, and Lécuelle, in 100 cases; 52 of these were normal subjects or suffering from non-syphilitic affections, and all gave a negative reaction; 37 cases with clinically undoubted syphilitic affections together with a strongly positive Wassermann reaction in the cerebro-spinal fluid all gave a positive benzoin reaction. On the other hand, 8 cases in which the clinical symptoms indicated syphilis gave a negative benzoin reaction, and in 3 doubtful cases the Wassermann reaction in the cerebro-spinal fluid was positive and the benzoin reaction negative. The writers' conclusions are as follows: (1) The colloidal benzoin test is negative in non-syphilitic affections, and practically constant in general paralysis and nervous syphilis in general. (2) Though less sensitive than the Wassermann reaction, except in the case of general paralysis, the benzoin reaction is simple, rapid, and practical.

556.

Amyloid Disease of the Lung.

ACCORDING to LOBEL and TEN THIJSE (*Nederl. Tijdschr. v. Geneesk.*, March 5th, 1921), who record a case of pulmonary, laryngeal, and intestinal tuberculosis in which amyloid disease was found in the lungs, as well as in the spleen, liver, kidneys, suprarenals, pancreas, and intestines, only six other cases of amyloid deposit in the lung have been described in generalized amyloid disease—namely, three by Tsunoda, one by Kschischko in a syphilitic lung, and two by Schilder in cases of chronic pulmonary tuberculosis. In Kschischko's case, as in that described by the present writers, there was interstitial pneumonia, thickening of the alveolar septa, and considerable hyperaemia. The writers think that amyloid disease of the lung is more frequent than the small number of cases reported would lead one to suppose. In none of the cases has it given rise to clinical symptoms. But although its clinical significance is not great, pathologically amyloid disease of the lung is of importance as showing the general dissemination of the disease throughout the body. The amyloid deposit is found both in the subepithelial and pericapillary tissue.

EPITOME OF CURRENT MEDICAL LITERATURE.

MEDICINE.

557. The Plantar Reflex in Early Life.

FELDMAN (*Brit. Journ. Child. Dis.*, January-March, 1921) examined the plantar reflex in 500 cases from birth up to the age of 7 years, the great majority being under 4 years. His conclusions were as follows: (1) The prevailing plantar response in early life is plantar flexion of the great toe, although, when a dorsiflexion of the toe occurs, it has not the same significance as a similar response in the adult. (2) The pyramidal tracts are sufficiently developed at birth (in cases born at full term) to give a normal adult type of plantar reflex even *in utero*, but, owing to easily aroused circulatory disturbances in early life, the consequent changes in the circulation in the cord are sufficient to compress the incompletely myelinated pyramidal tracts to evoke a Babinski response on one or both sides. (3) In premature infants the response is nearly always of the Babinski type, up to five or six weeks' post-natal life, because of the almost complete absence of myelination of their pyramidal tracts. (4) Bilateral plantar flexion is at all ages as common in girls as in boys, but bilateral dorsiflexion is at all age-periods in infancy more common in girls than in boys. (5) Breast-feeding during the first few weeks of life probably tends to diminish the incidence of a bilateral Babinski phenomenon. (6) Toxic influences, either from the bowel or other causes, do not affect the conductivity of impulses along the fibres of the pyramidal tracts. (7) Bilateral dorsiflexion is common in cases with a subnormal temperature. (8) The age at which the Babinski sign vanishes has no relation to the age at which the child begins to walk. (9) The reflexogenous zone is very diffuse in early infancy, and sometimes a plantar reflex (either flexor or extensor) may be elicited by stimulating a cutaneous area other than the sole when stimulation of the sole fails to evoke a response.

558. The Disinfectant Action of Urotropine.

NICOLAYSEN (*Acta Medica Scandinavica*, January 14th, 1921) has carried out numerous investigations, *in vitro* and *in vivo*, to determine the effect of urotropine and formaldehyde on microbes. He notes that formaldehyde in a concentration of 1 in 6,000 to 1 in 10,000 has a destructive effect on different bacteria, but for rapid disinfection considerably stronger concentrations than 1 in 6,000 are required by the coliform and typhoid bacilli. He tested the action of urotropine, under various conditions, on five strains of *B. coli* obtained from cases of pyelitis, and four strains of the typhoid bacillus. In acid urine cultures the urotropine had a powerfully inhibitory action, whereas when the reaction was neutral, even a comparatively strong dilution of urotropine did not have the slightest influence on the growth of the bacilli in a thermostat. It was also found that typhoid bacilli were more resistant to formaldehyde than coliform bacilli. Applying these and other findings to therapeutics, the author recommends a plentiful meat diet, as this promotes acidity of the urine. With the same object he prescribes 6 grams daily of acid sodium phosphate in addition to 3 grams of urotropine. He disagrees with the common practice of giving the patient much fluid, as this weakens the antiseptic action of the drug. He gives urotropine and acid sodium phosphate at bedtime so as to exploit the high acidity of the night urine. He admits, however, that with every precaution urotropine treatment does not always meet with a prompt response, and in the case of typhoid infection little good can be expected of urotropine treatment.

559. Paratyphoid Vaccination.

KARSTRÖM (*Uppsala Läkareföreningens Förhandlingar*, February 1st, 1921) observes that in Sweden epidemics of dysentery can almost invariably be traced to paratyphoid bacilli belonging to Group I (His-Russel's and the Y bacillus) or to Group III (Krusse's bacillus). The disease being epidemic in his neighbourhood, the author gave prophylactic injections of a vaccine made from Group I bacilli to inmates of a sanatorium and an asylum. Each person was given three injections (0.5 c.c.m., 1 c.c.m., and 2 c.c.m.) of the vaccine which contained one milliard of bacilli per cubic centimetre. Therapeutic injections were also given to patients suffering from chronic paratyphoid. At first the effect of this vaccination on the tuberculous seemed, in several cases, to be injurious; but when the

vaccination was conducted with greater caution and severe cases of tuberculosis were not treated, no injurious effects were observed. The author comes to the conclusion that, though a certain degree of immunity may be established by such vaccination, its duration is comparatively short. On the other hand, therapeutic vaccination was strikingly beneficial in chronic paratyphoid, and it had a marked effect on "carriers." By September, 1920, the author had succeeded in practically stamping out diarrhoea in his asylum, only one patient suffering at this date from chronic diarrhoea.

560. Pulmonary Silicosis.

MIDDLETON (*Journ. of Indust. Hygiene*, March, 1921) records a study of a series of cases of pulmonary disease in persons exposed to the inhalation of dust of high silica content occurring in general practice. Eighteen of the cases occurred in the manufacture of silica bricks and silica flour milling, 6 in scythe stone making, 16 in lead mining, 6 in quarrying, and 11 in stone dressing. The size of the silica particles observed in lung tissue were mostly less than 2 microns in diameter, so that the naked-eye appearance of atmosphere in a work place is no criterion of safety, since the most dangerous particles are invisible, and it is difficult to produce a satisfactory respirator without increasing the embarrassment of breathing for the wearer. The finest particles are the most harmful, as they produce progressive fibrosis through the lymphatic channels of the lung, and such dust is most dangerous at the moment of generation, before damping or agglutination has occurred. Some length of time may elapse before symptoms develop, and these may not occur until after an interval spent away from the particular industry. Silicosis predisposes to tuberculosis as the result of changes in the lung tissue, but it may prove fatal without any evidence of a superadded tuberculous infection. Physical signs may be present before the patient is aware of any definite symptoms, so that an important prophylactic measure is routine examination of all workers. Early signs most commonly occur in the right mammary region, where, above the fourth rib, the breath sounds become harsh, with a characteristic "whiffing" vesicular murmur below. Radiography is a valuable aid in diagnosis both of silicosis and of tuberculous foci. The disease usually runs a progressive course. The chief prophylactic measures aim at preventing the generation of dust at its source, obviating inhalation by the wearing of masks, and excluding any affected persons as early as possible.

561. Tea Intoxication.

STARR (*Med. Record*, March 19th, 1921) points out that tea may cause certain nervous symptoms, and, though cases of acute poisoning by tea are rare, chronic poisoning is much more common. Insomnia, despondency, and restlessness are among the mental symptoms following the abuse of tea, and from observations among servant girls about 10 per cent. of the cases of ordinary ill health were traceable thereto. In order of frequency the symptoms were headache, vertigo, despondency, palpitation, indigestion, insomnia, restlessness, mental confusion, constipation, loss of appetite, and tremors, the girls often being accustomed to drink as many as twelve or fifteen cups of tea a day. All the symptoms disappeared when tea-drinking was stopped. Investigations show that a dose of strong tea is followed in about twenty minutes by a marked increase in muscular power and endurance, which reaches its maximum in about an hour and lasts for several hours. Greater rapidity of thought, increased association of ideas, cheerfulness, and general mental activity also follow. In face of the universal use of tea, it should be borne in mind that occasional intoxication may occur and give rise to symptoms the actual cause of which may be easily overlooked.

562. Treatment of Myoclonic Encephalitis by Cicutine.

MARIE and BOUTTIER (*Bull. et Mém. Soc. Méd. des Hôp. de Paris*, March 3rd, 1921) state that the symptoms observed after intoxication by cicutine (conine hydrobromide) are in every way comparable with, though much less rapid than, those caused by curare. Cicutine has a paralysing action as long as the arterial circulation of the limb is preserved, but it has no

action if this circulation has been interrupted by a high ligature. Marie and Bontier have found that subcutaneous injection of cicutine in non-toxic doses has a sedative action on certain convulsive or spasmodic manifestations, especially those connected with lethargic encephalitis. They employ the following two different methods according to the cases: (1) If the symptoms are very marked, they start with a small dose and give only $\frac{1}{2}$ mg. the first day to test the susceptibility of the patient. A daily dose is then given for four or five days and increased from 1 to 3 mg. according to the state of the patient and the effect obtained. After five days the drug is usually suspended for two or three days, during which an examination is made of the urine, the reflexes, and the blood pressure. (2) When the myoclonic symptoms become less intense, but are still persistent and refractory to treatment, the injections are given only two or three times a week. The subsequent procedure depends upon whether there is a tendency to improvement, in which case the same doses are continued, or the reverse, when the dose is progressively increased if the drug is well tolerated. The writers have no doubt that there is a relation between the treatment employed and the results obtained, interruption of the injections being frequently followed by a reappearance or increase in amplitude of the myoclonic movements. On the other hand, cicutine has no effect on the choreiform movements of lethargic encephalitis or in ordinary chorea.

563. Vascular Sclerosis.

MÜNZER (*Wien. Arch. f. inn. Med.*, December 15th, 1920) gives the following description of the varieties of vascular sclerosis: (1) Sclerosis of the aorta and large arteries which is known as arterio-sclerosis is a disease of old age, and especially of men. It is characterized by tortuosity of the peripheral vessels and a large pulse without any change in the blood pressure, and also by attacks of pain in various organs (heart, legs, intestines) when much call is made upon them. (2) Arterio-capillary sclerosis or capillary sclerosis occurs in youth also and is equally frequent in males and females. The symptoms are as follows: (a) Permanently raised blood pressure which reaches increasingly higher grades as the disease progresses; (b) hypertrophy of the left ventricle; (c) moderate and occasionally only transient polycythaemia. In addition to these constant manifestations the symptomatology of arterio-capillary sclerosis depends on the functional disturbance of the organs specially affected. One of the chief causes of this condition is to be found in acute infectious diseases, which are accompanied by general disease of the capillaries. Gout is also closely associated with this condition. (3) The pulmonary artery may be affected just like the aorta both in its trunk and in its peripheral branches. Sclerosis of the arteriolo-capillaries of the pulmonary artery constitutes an independent disease and forms the anatomical substratum of true rarefying emphysema, being characterized by general cyanosis, a high degree of polycythaemia and hypertrophy of the right ventricle. Münzer suggests that there may be also a sclerosis of the capillaries of the portal vein and that this disease may be the substratum of atrophic cirrhosis of the liver.

564. Treatment of the Excitement Stage in Anaesthesia.

KULENKAMPPF (*Zentralbl. f. Chir.*, February 12th, 1921) has found that in patients anaesthetized by ether or ether and chloroform the excitement stage can be made to disappear in thirty to sixty seconds by large doses of ethyl chloride. A good drop bottle is required from which 100 to 200 drops of ethyl chloride can be given rapidly. The anaesthesia becomes suddenly very deep, and ether or ether and chloroform anaesthesia can rapidly be resumed. The method (as might well be supposed) is not entirely harmless, because rapid methods have always some danger connected with them, but Kulenkampff regards it as less dangerous than large doses of chloroform.

565. Acute Articular Rheumatism and Acute Otitis Media.

POPPER (*Med. Record*, February 12th, 1921) records a case of acute articular rheumatism following acute purulent otitis media, which is of interest on account of its rarity, and because it was mistaken for the commoner condition of a bacteraemia following severe middle-ear trouble and simulating rheumatism. When first seen the patient was regarded as suffering from some form of sepsis, but in the absence of chills, and with a negative blood culture, he was treated with salicylates with rapid and marked relief of symptoms. This case suggests the possibility of acute

articular rheumatism not being a definite pathological entity but rather a symptom-complex secondary to some focus of infection. The author suggests that herein lies the explanation of the connexion with infected tonsils, or with infections of the nasopharynx, ear, nasal sinuses, and teeth.

SURGERY.

566. Dyspeptic Symptoms Due to Chronic Appendicitis.

WILDENSKOV (*Ugeskrift for Læger*, February 17th, 1921) has found that of 175 cases of appendicitis operated on at his hospital during the last two and three-quarter years 36 (20.6 per cent.) proved to be chronic cases. Among these were 12 cases in which the histories and the physical examination did not indicate appendicitis. After giving details of several of these cases, 9 of which were females between the ages of 14 and 32, the author points out that the chronic inflammatory changes of the appendix had given rise to an almost infinite variety of abdominal symptoms. There had in several cases been pain in the epigastric and umbilical regions, radiating thence to the back. The attacks had often begun directly after a meal, becoming worse on movement. Pyrosis, nausea and vomiting were common symptoms, but not one of the patients showed signs referable to the right iliac fossa. In as many as 8 cases there was a history of prolonged and severe constipation. Examination of all these 12 patients three months to two years after the operation showed that 10 had completely recovered from their pain and dyspepsia, and the remaining 2 had greatly improved. But of the 8 patients with chronic constipation, 5 still suffered from it. The author's paper is a plea for close co-operation between surgeon and physician so as to save many a case of chronic appendicitis from long periods of fruitless dietetic, medicinal and expectant treatment.

567. A Simple Operation for Prolapse of the Rectum in Childhood.

MÖLLER (*Hospitalstidende*, February 23rd, 1921) warmly recommends Ekehorn's operation for prolapse of the rectum, which he has performed in 15 cases with immediate good effect and without other complications than slight stitch abscesses. The results were permanent in the 12 cases which he was subsequently able to control. The operation, which was described in 1909 by Ekehorn in *Upsala Läkareförenings Förhandlingar*, consists of attaching the posterior wall of the rectum to the sacrum by a transverse suture. After the prolapse has been corrected and the gut held in the required position by the forefinger of the left hand, a needle is passed through the skin to one side of the lower end of the sacrum, and is carried through the soft tissues so as to pierce the rectum and meet the finger therein, which guides it to the anal orifice. The needle being threaded with stout silk is drawn back again. The same procedure being repeated on the other side of the sacrum, the two ends of the silk ligature protruding at the back, one on each side of the sacrum, are knotted together, and the suture is kept in place for a fortnight. The author contrasts the prompt effect of this operation with the tediousness of conservative treatment with sticking-plaster.

568. Loose Bodies in Knee-joint.

BLANCO (*Journ. Orthopaed. Surg.*, March, 1921) discusses the etiology of loose bodies in the knee-joint, with notes of a case of rare type and associated with hypothyroidism. Both knees showed by x-ray destructive processes in the condyles of the femurs and articulating surfaces of the tibiae, the condyles of the femurs being flattened out. At operation the normal convex surfaces of the condyles were found to be changed to concavities, and loose bodies were felt on deep pressure and were removed from the internal condyle through an incision in the cartilage. Distinct hypothyroidism was present, as evidenced by puffiness of the face, dry skin, brittle hair, and low basal metabolism, and a definite infection of the tonsils was present. Three weeks after the operation on the knees the tonsils were removed, the left one containing pus, and following their removal there was a severe local and general reaction, but the knees were not involved therein. The extensive pathological changes may be regarded as the result of abnormal brittleness of bone due to metabolic disturbance, and in this case there was definite evidence of hypothyroidism with low metabolic rate. Although these changes in bone, associated with

low metabolic rate, have not been investigated, there is sufficient clinical evidence to suggest their relation to hypothyroidism.

Alveolectomy.

569. GROSS (*Med. Record*, March 19th, 1921) considers that the surgical removal by alveolectomy of diseased or jagged buccal or lingual portions of the alveolar processes of either jaw is of great value in the treatment of trifacial neuralgias of local origin. Injuries to the alveolar processes resulting from extractions of teeth, pressure from tooth fragments, abscesses, impacted teeth, and granulomata may cause trifacial neuralgia occurring in paroxysms, and the majority of such cases are of local origin with frequently the local cause undiscovered and unremoved. After exposing the alveolus by incision through the buccal mucoperiosteum and separating the flaps from the bone, the latter is made quite smooth and rounded by the use of an alveolar plane designed by the author, great care being taken to remove all diseased and jagged bone tissue. By this means all conditions acting as local irritants to the overstimulated peripheral nerve endings are removed, causing complete cessation of the severe paroxysms.

570. Mesenteric Cysts in Infancy.

VALENTE (*La Pediatria*, February 1st, 1921) reports a case of mesenteric cyst successfully operated upon in a child of 6 years. These cysts may occur (but very rarely) in suckling infants. Usually they are benign and may contain serum, chylous fluid, or blood; occasionally they are parasitic in origin (echinococcal). Generally speaking they arise from the mesentery, but they may spring from the intestine, from the retroperitoneal glands, or from the remains of the Wolffian body. In early infancy they are mostly of embryonic origin. They are of slow development and produce their effects, if any, by mechanical or functional disturbance of the neighbouring viscera.

571. Auto-vaccination for Acute Suppurative Otitis Media.

GONZÁLEZ (*Revista Sud Americana Endocrin.*, February, 1921) in all cases of acute otitis media after puncture of the membrane cultivates a vaccine from the pus. The first injection is followed by an increase of the otorrhoea, but with successive injections given twenty-four hours after the reaction produced by the antecedent treatments the discharge becomes serous and is rapidly diminished. FAIREN (*Ibid.*) relates a curious case of otitis due to *B. pyocyaneus* and cured after seven injections of an auto-vaccine.

572. Cysts of the Anterior Part of the Nasal Fossae.

ACCORDING to GIGNOUX (*Rev. de lar., d'otol., et. de rhinol.*, February 15th, 1921), who records three illustrative cases—two in women and one in a man—cysts of this kind are relatively rare, since only 52 cases were collected by Briggemann in 1920. They are situated on the floor of the nose at the anterior part of the nasal fossae. The cyst is generally unilateral and single, though double cysts have been reported by Halle and Killian. With two exceptions, one of which is described by Gignoux, all the cases on record have occurred in adult females. The onset of the affection is insidious. The cyst does not cause any pain unless it becomes inflamed, when a rapid increase in the size of the tumour takes place. In most of the recorded cases the tumour was the size of a hazel-nut, but its size may vary from that of a pea to that of a mandarin orange. When it has reached a certain size it causes some deformity and obstruction of the corresponding nostril. A fistula may form in the cyst and open into the nose. The contents of the cyst are constituted by a yellow mucous fluid. The wall is thin and is frequently torn on dissection. Treatment consists in removal of the cyst through the gingivo-labial fold.

OBSTETRICS AND GYNAECOLOGY.

573. Continuous Ether Narcotization during Childbirth.

IN a preliminary communication (*Zentralbl. f. Gynäk.*, March 19th, 1921) WEDERHAKE describes his method of inducing, by narcotization with ether (together with a little chloroform), amnesia during parturition. From the onset of labour the anaesthetic is administered on the author's double mask; 3 grams of chloroform having been given, deep ether narcosis is induced, after which the patient is maintained in a state of post-narcotic amnesia

by means of smaller doses of ether. She can understand and obey spoken injunctions, but after the end of labour has no recollection of the incidents accompanying it. During the terminal part of the second stage chloroform is given, both with the object of deepening the narcosis and in order, by checking the strength of the uterine contractions, to diminish the risk of perineal tears. Compared with scopolamine and morphine narcosis, Wederhake claims that his method, which he has used in 247 labours, has the advantages of being without injurious effect on the child, and (owing to the stimulating effect of ether on the uterine musculature) of shortening labour and doing away with the necessity of applying forceps.

574. Small Mucous Polypi of the Corpus Uteri as a Cause of Haemorrhage.

ALAMANNI (*Ann. di Ostetricia e Ginecol.*, January, 1921), in a communication to the Società Toscana di Ostetricia e Ginecologia, drew attention to the important part played in the genesis of intractable menorrhagia and metrorrhagia by small mucous polypi of the body of the uterus, particularly those situated in the fundus, near the openings of the Fallopian tubes. Records are given of (1) three cases in which the presence of such a polypus was the only anatomical abnormality which could have accounted for the symptoms; (2) three cases in which a polypus in the fundus was probably an important contributory cause of the haemorrhage, in association respectively with a minute interstitial myoma of the body, a small cervical myoma, and a cystic degeneration of one ovary; (3) three cases in which, in addition to the polypus, there were also present, singly or in combination, distinct enlargement of the uterus, perivascular sclerosis of the myometrium, and adnexal abnormalities. In several instances curetting antecedent to hysterectomy had failed to reveal or remove the polypus.

575. Operation for Sterilization.

ACCORDING to FLATAU (*Zentralbl. f. Gynäk.*, April 2nd, 1921) more than thirty methods have been proposed for securing, by operative interference with the Fallopian tubes, subsequent sterility of the patient. However carefully performed, division, partial excision, extirpation and various ligature operations are all liable, in certain instances, to fail to produce the desired result. In five cases the author (in the course of operations for prolapse) has crushed both tubes by the application for five minutes of a powerful clamp; although the crushed region of the tubes was reduced to the thickness of tissue-paper, each of the five patients subsequently became pregnant. It has occurred to Flatau to try the effect of tying a knot in the tube, in the same way as is done in the case of the upper end of the ureter (accidentally divided in pelvic operations) by Kawasoye, Stoeckel, and others. In six cases, therefore, after freeing the tube along its whole length he has tied a tight knot in the middle. The cases are too recent for the success of the manoeuvre yet to be reported on, but the author argues that if knotting is successful in destroying the permeability of the ureter, it is still more likely permanently to close the Fallopian tube, which, unlike the ureter, is not exposed to the pressure of a fluid continuously secreted at relatively high pressure.

576. Obstetric Tears of the Tentorium Cerebelli.

ACCORDING to ZANGEMEISTER (*Zentralbl. f. Gynäk.*, April 2nd, 1921), tears of the tentorium are the most frequent cause of intracranial haemorrhage in the newborn. Of 27 consecutive cases, a rent in the tentorium could be demonstrated in 17, and with certainty excluded in 4 only. On the other hand, of 24 such tears demonstrated at autopsy, 6 were unattended by intracranial haemorrhage. In this series the presentation had been: brow 2, breech 3, transverse 2, vertex 17. Forceps had been applied in 5 cases only. The aetiological factors concerned are: (1) diminution in the resistance of the foetal skull—for example, from imperfect ossification or premature birth; (2) mechanical obstruction to birth—for example, from contracted pelvis; (3) increased pressure on the head—such as that which follows, for example, from abnormally strong pains. In 22 out of 28 cases birth had been preceded by some degree of intruterine asphyxia of the foetus, due to prolapse of the umbilical cord, to placenta praevia, or to premature placental detachment.

577. Ventrofixation of the Vagina.

GOLDSCHMIDT (*La Gynéc.*, January, 1921) described to the Obstetrical and Gynaecological Society of Vienna the case of a woman who since 1904 had undergone the following

operations: anterior and posterior colporrhaphy, with ventrofixation of the uterus; amputation of the cervix; total abdominal hysterectomy for suppurative salpingitis. In 1914, the vagina having prolapsed, vaginal ventrofixation was performed, together with colpoperineorrhaphy. A similar operation was performed (for a recurrence) in 1919. In similar cases Adler and Lutzko have seen successful results follow fixation of the prolapsed vagina to the sacral promontory or to the rectus abdominis muscles.

578. Retinitis during Pregnancy.

COUVELAIRE (*La Gynéc.*, January, 1921) relates the history of two cases in which retinitis was the first morbid symptom encountered during pregnancy. Developing in the first half of the period of gestation, it was followed by oliguria and albuminuria, without excess of nitrogen in the blood. BRINDEAU (*Ibid.*) has had a similar case: he terminated the pregnancy by vaginal Caesarean section, and when, in the second month of a subsequent pregnancy, similar troubles appeared, he again emptied the uterus and (after anterior colpotomy) divided both Fallopian tubes. Couvelaire, however, does not think that systematic sterilization in these cases is justifiable.

PATHOLOGY.

579. Alkaptonuria.

ACCORDING to ROMBACH (*Nederl. Tijdschr. v. Geneesk.*, March 5th, 1921) who records a case detected during life insurance examination, alkaptonuria was first discovered in 1859 by Boedeker, who was, however, unable to determine the nature of the condition. Subsequently Ebstein, Müller, and others isolated alkapton and called it homogentisic acid. While Wolkow and Baumann maintain that its formation takes place in the alimentary canal as the result of the action of bacteria, other investigators assert that the tissues of alkaptonuric patients produce this acid, which is thus a metabolic product. During starvation the excretion of this acid continues, so that it must be derived from the organic albumin. Homogentisic acid has been isolated by Abderhalden and Falta from the blood serum and by Garrod from the sweat. Umber reports some cases in which he found a greenish-blue discoloration in the axilla, which was probably an excretory product of the sebaceous glands. In Rombach's cases ochronosis was also present—that is, a dark blue staining of the cartilages, especially of the concha, visible through the skin. Unlike Falta, who maintains that homogentisic acid is always present in man as a normal intermediary product of metabolism, Grotterink and Hijmans van den Burgh have found that in persons who do not suffer from alkaptonuria homogentisic acid is not a normal intermediary product of metabolism. According to this view alkaptonuria is thus a condition in which the power of oxidizing homogentisic acid is lost. Rombach concludes by quoting Hijmans van den Burgh's statement that alkaptonuria is an entirely harmless phenomenon.

580. Parathyroid Transplantation In Post-operation Tetany.

DRÜNER (*Zentralbl. f. Chir.*, February 19th, 1921), who has not seen a single case of tetany occur after 144 operations for removal of goitre, describes the results of his study of the parathyroids in the cadaver. Tissues supposed to be parathyroid were removed from about twenty corpses, imbedded, and cut in serial sections. In the first two cases three parathyroids and in the third four parathyroids were found. In more than a third of the remaining cases the tissues removed proved to be small lymph glands or fragments of goitre. The parathyroid glands therefore cannot be identified by their topographical anatomy. Moreover, owing to the possibility of mistaking a lymphatic gland for a parathyroid, there is a possibility of transplanting a tuberculous lymph gland, so that the operation is not only uncertain but also dangerous. Lastly, owing to the highly organized circulation of the parathyroid, an injury to it may be sufficient to impair the vitality of the glands. Transplantation, therefore, is not likely to be successful if this circulation is not re-established after the operation.

581. Sachs-Georgi Reaction.

LEVINSON and PETERSEN (*Arch. of Derm. and Syph.*, March, 1921) conclude, from an examination of 1,042 serums and cerebro-spinal fluids by the Wassermann and Sachs-Georgi reactions, that (1) there is a close parallelism in the two reactions in 92 per cent. of cases; (2) that in the 62 cases

in which the Wassermann was negative while the Sachs-Georgi was positive or doubtful the clinical history or examination revealed evidence of syphilis in 58 per cent. The technique of the Sachs-Georgi is simple, only one biological reagent being required—antigen—instead of four in the Wassermann test. This simplicity adds to the uniformity of the results. Because of its simplicity and the fact that it is frequently positive in syphilitic cases when the Wassermann is negative, they are of the opinion that the Sachs-Georgi reaction offers a valuable aid in the routine examination for syphilis when used in conjunction with the Wassermann reaction.

582. The Action of Intravenous Injections of Calcium Lactate on the Blood Picture.

RÖSLER (*Wien. Arch. f. inn. Med.*, February 15th, 1921) investigated the action of intravenous injections of calcium lactate on the blood picture, including the blood platelets; 0.10 gram of calcium lactate in 10 c.c.m. of normal saline was given, and the blood examined half an hour after the injection. After preliminary trials with normal persons, cases of latent malaria which had not been given quinine were chosen, as they all had a definite blood picture consisting in lymphocytosis in which the changes could be readily studied. The results were as follows: (1) A 6 to 18 per cent. increase of the polymorphonuclear neutrophil leucocytes at the expense of the lymphocytes with little or no increase in the total number of leucocytes. The neutrophil leucocytosis lasted some hours. The nature of its occurrence could not be explained. (2) Morphological and quantitative changes occurred in the blood platelets, indicating rapid destruction. The diminution in the number of the platelets was accompanied by a shortening of the coagulation time.

583. The Thermo-Precipitin Reaction in the Diagnosis of Renal Tuberculosis.

WIGET (*Archiv. Ital. di Chirurg.*, December 20th, 1920) has tested Ascoli's thermo-precipitin reaction in renal tuberculosis, and speaks very favourably of it. In the 25 cases briefly recorded, 16 gave a positive result both to Koch's bacilli and the thermo-precipitin reaction, and of these 16 the result was confirmed by operation in 13. In two cases where the test was negative at operation the kidney was found completely shut off. In the 7 remaining cases the renal trouble was non-tuberculous. In two cases tubercle bacilli were present in the sputum but not in the urine, and the thermo-precipitin test was negative. One advantage of Ascoli's test is that it can be applied in decomposing urine. It was found active in urine sediment two or three months old. The urine must be well filtered to get a good result, and as a rule the cloudiness does not appear for five to fifteen minutes.

584. The Undescended Testis.

MICHON and PORTE (*Lyon Chir.*, November-December, 1920) record their examinations of six undescended testes removed at operation. The ages of the patients ranged from 14 to 26 years, all save one having reached puberty. There were clear signs of spermatogenesis in one case, and possibly in one other; in the remaining four it was absent, section showing pre-pubertal appearances (ages 14, 16, 17, and 26 years). The tubules appear to be narrower in the absence of spermatogenesis. The interstitial cells become more abundant as age advances. When few they form little groups of three to eight cells; when many they form little islets of some size. These cells may even form little glands—the "para-epithelial masses" of Hansemann and others. The authors believe that a quantity of intertubular fat is evidence of degenerative processes; there was but little in the testes showing signs of spermatogenesis.

585. Infective Irritation of the Bone Marrow.

LÖWY and DIMMEL (*Wien. Arch. f. inn. Med.*, February 15th, 1921) record five cases showing that in severe septicæmic infections changes in the blood occur resembling those found in leukaemia and pernicious anaemia as well as a high degree of mononucleosis, although leukaemia and pernicious anaemia can be excluded by the *post-mortem* findings, more careful examination of the blood and the clinical course. A comparison of the blood findings in various individuals enables a theoretical series to be formed ranging from septic polymorphonucleosis to a leukaemic blood picture. The causes of these changes in the blood and of the mononucleosis is the constitutionally different reaction of the haematopoietic system in various individuals. In chronic malaria transitional forms from myeloblasts to mononuclears are found, which are to be regarded as derivatives of the bone marrow.

EPITOME OF CURRENT MEDICAL LITERATURE.

MEDICINE.

586.

Encephalitis Lethargica.

ZUCCOLA (*N. Morgagni*, February 28th, 1921) publishes a full account of this disease, based on an experience of 25 cases with a mortality of 36 per cent. The period of incubation is difficult to determine. The three cardinal symptoms are (1) paralysis of the cranial nerves, especially affecting the ocular muscles; (2) lethargy; (3) fever. The ocular paralysis is more of the nature of a paresis than a true paralysis; nystagmus is fairly frequent. Of the cranial nerves the right facial is most often affected. Static strabismus is exceptional. Cases with marked phenomena of motor excitability are usually serious. The reflexes, vasomotor reflexes, sensibility, neuralgic pains, ear troubles, are discussed. Lethargy is not a constant symptom, but sleepiness is very common. In natural sleep the eyes are turned upwards and outwards; this is not the case in the sleep of encephalitis lethargica. Whether this sleepiness is due to some affection of the hypophysis is fully discussed, and a decision left open; in some cases there seems a certain relation, but not in all. One ought to speak of a centre for wakefulness rather than a centre for sleep. The temperature usually increases and defervescence is by lysis. The pulse is generally independent of the temperature; bradycardia is a bad sign. Meningeal symptoms vary in intensity. The cerebro-spinal fluid usually issues at low pressure. The Wassermann reaction is negative. Leucocytosis is generally present, but is not very marked. The kidneys are not affected. The macroscopic and microscopic appearances in the brain are described. Then follows a description of the various clinical forms (hyperkinetic, delirious, ambulatory, soporous). As to the relation between influenza and encephalitis lethargica the author is not prepared to give a definite opinion; there is much to be said on both sides. Various experiments with germs are described. Prognosis should be reserved. The differential diagnosis is discussed and certain therapeutic measures—for example, lumbar puncture, urotropin, and various serums—are referred to, but without any confidence as to the benefit derived therefrom.

587. ELY (*Journ. of Nervous and Mental Disease*, February, 1921) calls attention to the residual symptoms, chronicity, and relapsing tendency in epidemic encephalitis, which sometimes remain after the immediate attack is over. Some cases drift into a subacute or chronic state which may last for many months, and in some a distinct relapsing tendency occurs, in which newly localized symptoms appear with an almost typical reproduction of the original symptoms, and even the mildest attacks frequently leave the patient incapacitated for a long time for full participation in his work. The symptoms are protean in character, and tend to prove that both the central and peripheral nervous structures become susceptible to some irritant generated by the invading micro-organism. The irritant causing the root pains and myoclonic muscle contractions successively involves different segmental levels of the cord or its corresponding nerve roots, thus giving rise to descending and ascending forms of radiculitis, and the motor nuclei and roots of the cranial nerves are not immune to its effects.

588. BONHOEFFER (*Deut. med. Woch.*, March 3rd, 1921) notes that since the middle of December, 1920, epidemic encephalitis has flared up again in Berlin, and that in the course of six weeks he has seen as many as 25 new cases. The course of the disease was very varied; a few cases terminated fatally soon after the onset of the disease; but recovery was the rule, and the author could not confirm the teaching of the Vienna school, according to which a third of all the cases prove fatal. In the absence of pneumonia and other complications he found the disease ran a favourable course. The prognosis was bad when the disease was complicated at the beginning by severe delirium, collapse, and high fever. Provided the patient survived the disease by a few weeks, the prognosis was good; but in one case death occurred as late as the third week, paralysis of the muscles of deglutition being followed by bronchopneumonia. Pneumonia, by the way, was almost invariably found *post mortem*. The changes found *post mortem* in the trachea and bronchi coincided

closely with those of influenza, and as the two epidemics came and went at the same time, the author suspects a more than accidental relationship. The action of arsenic and salicyl preparations was uncertain, but in one case lumbar puncture was rapidly followed by improvement in the patient's condition.

589

Polyneuritis following Influenza.

KLFIN (*Wien. Arch. f. inn. Med.*, February 15th, 1921) records six cases of post-influenzal polyneuritis which developed on the average six weeks after the acute symptoms of influenza had subsided. All the patients were women, and three were members of the same family (grandmother, mother, and daughter). The symptoms consisted in each case of spontaneous pain, marked tenderness of the muscles and nerve trunks, disturbance of the reflexes, and in severe cases of flaccid paralysis of symmetrical distribution with partial reaction of degeneration. Sensory disturbances occurred in the form of a combination of hyperalgesia of the skin and hypaesthesia to touch and temperature with disturbance of stereognosis. Three cases showed a combination of polyneuritis with symptoms of encephalitis, and in one of these cases there was possibly a change in the spinal cord in the form of poliomyelitis. Treatment consisted at first in warm applications, diaphoresis, administration of salicylates, and later in faradization, galvanization, and massage. All the cases reacted very well to treatment with one exception, in which the symptoms were probably due to poliomyelitis.

590.

The Prevalence of Scarlet Fever.

NIELSEN (*Tygeskrift for Læger*, March 3rd, 1921) has investigated the morbidity and mortality of scarlet fever in Denmark since 1877, comparing the incidence of the disease in Copenhagen, provincial towns, and the country. He finds that any slight tendency scarlet fever may show to die out is counterbalanced by the migration of the population from country to town, the frequency of the disease being directly proportional to the density of the population. Studying the incidence of the disease in different age-periods, he found that there was little or no change in the mortality, but when he took every age in one group he found a definite decline in the mortality. This decline proved to be due to the disease being less frequent in children under the age of 5, and this, again, was due to the more effective isolation of cases. A study of epidemics of scarlet fever showed that children of school age were the first to fall ill, and only at a later stage of an epidemic did children under 5 develop the disease in considerable numbers. But though school children would thus seem to bring infection to the younger children, they do not necessarily contract the disease at school. Indeed, thanks to school supervision, many slight cases, which would otherwise have passed unnoticed, are detected. It was found that under the age of 1 the mortality was about 14 per cent. It fell to 4½ per cent. in the age-period 1 to 5, and after the fifth year it was only 2 per cent.

591 The Schultz-Charlton Test for Scarlet Fever.

In 1917 Schultz and Charlton described a diagnostic test in doubtful cases of scarlet fever. Excluding cases in the first four days, they said that when a human serum was injected, at the site of injection the scarlet fever rash disappeared and remained absent for a long time in true cases of scarlet fever. They called it an extinction phenomenon. TRON (*Riv. Med.*, January 15th, 1921) has tested this method of diagnosis in 50 cases of scarlet fever, giving 99 trials with human serums from various affections. His results do not confirm those of Schultz and Charlton, for he only got 26 per cent. positive results. As a reliable diagnostic test it therefore does not seem of much value, however interesting the phenomena of "extinction" may be from a pathological point of view.

592

X-Ray Therapy In Hyperthyroidism.

BARKER (*New York Med. Journ.*, February 12th, 1921) considers that before using Roentgen ray therapy the mediastinum should be screened, in order to determine the presence of intrathoracic thyroid or hyperplasia of the thymus. Full high penetrating doses should be given with the anode 8 in. from the skin, and repeated every four weeks, in order to be able to note the effect before repeating the dose. Subjective symptoms are the first to be relieved,

the patient becoming less nervous and irritable, with less palpitation and sleeping better. Of objective symptoms the tachycardia is the first to improve, and its amelioration affords the best guide in discontinuing the treatment. Since the ray will stop secretion of the normal gland, it must never be used merely to reduce the size of the gland, and its use is contraindicated for cosmetic effects, pressure symptoms, cystic degeneration and malignancy, in which cases surgery is preferable. The author concludes that x-ray therapy will take the place of surgery in the treatment of hyperthyroidism; by inhibiting cell action it produces good results without scar formation, and without the dangers attending operation.

593. The Pituitary in Graves's Disease and Myxoedema.

FRIEDMAN (*New York Med. Journ.*, March 2nd, 1921) suggests the possibility that there may be a mild overactivity of the pituitary in Graves's disease, and a mild underactivity in myxoedema. Histological changes occur in the hypophysis in Graves's disease similar to those in hyperpituitarism, and in myxoedema similar to those in hypopituitarism, pointing to some degree of hypophyseal overactivity in hyperthyroid, and of hypophyseal underactivity in hypothyroid states. Chromophilia of the anterior lobe is characteristic of Graves's disease, and chromophobia of myxoedema. The increased metabolic rate, the tendency to glycosuria, mental irritability, intestinal spasticity, tendency to miscarriages, and altered skeletal growth are some of the symptoms and signs of Graves's disease which may be in part attributable to hypophyseal overactivity, while the opposite findings in myxoedema may be due to hypophyseal underactivity. From these considerations pituitary products are contraindicated in the treatment of exophthalmic goitre, and are indicated in addition to thyroid in the treatment of myxoedema.

594. Insomnia in Children.

REH (*Rev. méd. Suisse rom.*, March, 1921) records two cases in children, aged 7 and 7½ years respectively, observed at the Geneva Children's Clinic, closely resembling those recently described by Hofstad in the Munich Children's Clinic in their symptomatology, but differing from them as regards their etiology. In the first case the symptoms appeared after an attack of influenza, while in the second case there was no previous organic affection. Hofstad's 21 cases were classified as follows in regard to their etiology: In 5 cases the symptoms occurred in children admitted to hospital with lethargic encephalitis. In 9 there was a history of influenza accompanied by drowsiness or choreiform movements which were undoubtedly examples of lethargic encephalitis. In the remaining 7 cases there was no history at all of any previous disease; but owing to the similarity of the symptoms Hofstad regarded them as an incomplete form of lethargic encephalitis. During the day the majority of the patients were psychically normal and played with their comrades, a few appeared to be reserved and shy or slightly excited. The nocturnal insomnia was characterized by retardation and diminution of sleep, which might last for weeks or months, giving rise to a state of anaemia and profound emaciation. Unlike Hofstad's cases, which at the time of publication of his paper had not shown any improvement for weeks or months, both Reh's patients recovered—one after seven months and the other after eleven months. In each case normal sleep returned after an attack of measles independently of any treatment, to which both cases had proved refractory.

595. The Diet in Typhoid Fever.

MARAÑÓN (*Arch. de med., cir. y espec.*, February 15th, 1921), as the result of observations on 300 cases of typhoid fever fed on mixed diet and of 1,000 on milk only, maintains that in the great majority of cases a mixed diet does not aggravate the febrile process, but rather diminishes it, and so far from increasing the frequency of complications, places the organism in an incomparably better position of nutrition than in the case of typhoid patients fed on milk only. Since a mixed diet has been adopted the emaciated type of patient has disappeared from Marañón's wards, and all his cases have maintained throughout their illness a fair state of nutrition and their convalescence has been of short duration. The diet recommended by Marañón consists of a litre of milk daily, accompanied by meat juice, yolk of eggs, biscuits and butter, boiled fish, and fruit juice. He rejects the idea that a mixed diet is more dangerous than a purely milk diet in typhoid fever. The patients take a mixed diet better, and suffer less from meteorism

than when on milk alone. Moreover, it is rare to find in these patients *post mortem* the scybala which are often caused by a milk diet.

596. Symmetrical Tuberculous Ulceration of the Labial Commissures.

BETTAZZI (*Il Policlinico, Sez. Chir.*, December 15th, 1920) records a case in a man, aged 46, which presented the following features: (1) Initial leucoplasmia; (2) atypical character of the lesions; (3) development of specific ulceration of the buccal mucous membrane in an individual who had been cured some years previously of a plero-pulmonary affection which was almost certainly tuberculous; (4) apparent recrudescence of old tuberculous disease at the apex, probably due to a true exogenous reinfection with buccal localization. The tuberculous nature of the lesion was demonstrated by microscopical examination; the ulcer was freely excised and complete recovery took place.

SURGERY.

597. Treatment of Fractures of Spongy Bones.

NATHAN (*Amer. Journ. Med. Sciences*, April, 1921) discusses the pathology and treatment of fractures of the spongy bones. Experimentally and clinically it is found that trauma, with or without fracture, of spongy bones, or of the epiphyseal ends of long bones, induces inflammatory changes closely resembling the non-suppurative infective processes in such structures, leading to bone softening and absorption, which renders them liable to distortion when subjected to weight bearing. Such traumatic inflammation is accompanied by intra-, peri-, and para-articular exudation likely to induce permanent arthritic abnormalities. Though premature mobilization is harmful, fixation should not be unduly prolonged lest ankylosis result, and only experience and constant observation when and to what extent each individual case requires movement, and objective conditions, such as the relaxation of muscular spasm and subsidence of swelling, are to be relied upon in judging the course to pursue. In the upper extremity the restoration of complicated and highly specialized movements is the therapeutic aim, while in the lower extremity weight bearing is a more important function than complete joint movement. Severe trauma to the back requires rest in bed or immobilization immediately after injury, even when the objective signs are negative, because of the tendency for subsequent decalcification and bone absorption to come on gradually and not until some time after the injury. In serious cases immobilization with plaster or a back brace must be continuous. In fractures near the joints of the lower extremity, provided the fragments are held in apposition, immobilization with early locomotion promises the earliest and surest results, but traumas of the tarsus resemble those of the spine in that the tendency to arthritis and distortion sometimes continues for a long time after injury. Long-continued supervision is required, and a support—such as a modification of the Whitman plate—to prevent valgus, should be worn for some months.

598. Surgical Treatment of Tuberculosis of the Bones and Joints.

CHIEVITZ (*Hospitalstidende*, March 2nd, 1921) has investigated the after-histories of 233 cases of surgical tuberculosis treated at Professor Rovsing's hospital on surgical lines, ranging from immobilization to resection. The observation period was from six to sixteen years. He tabulates his results according to the site of the disease. In 40 cases of hip disease there were 11 deaths, all within the first year of treatment. Of 14 of these cases discharged with fistulae 8 had subsequently healed. Though it usually took several years for the patient to regain his working capacity, the author expresses amazement at the permanency of the cures ultimately effected. A study of the 65 cases of disease of the knee brought out the point that resection quickly restores the patient's capacity for work; this was achieved by 21 patients within six months of the operation. Of the 14 deaths in this class, 10 occurred within the first two years of treatment. In every class of case the mortality was practically confined to the first year or two; after this interval the mortality from tuberculosis was almost negligible. The author also found that, though new clinical manifestations of tuberculosis might be separated by an interval of several months, they yet represented one and the same process in most cases. This view that the different manifestations originated at the same time, although they became clinically demonstrable

at different times, was supported by the observation that in 16 out of 22 cases of multiple foci the new manifestations occurred within a period of only one year.

599. Extraction Operation for Varicose Veins.

COLT (*Brit. Journ. Surg.*, April, 1921) reports the late results in twenty cases of Babcock's extraction operation for varicose veins. It is the operation of choice for most cases, especially early ones in which the internal saphenous vein is involved. A general anaesthetic is advisable when numerous other veins and adjacent tributaries have to be ligated, divided or excised, though local infiltration with 0.25 per cent. novocain over the sites of incision may often suffice. With the patient in slight Trendelenburg position it is important to tie and divide the saphena close to the saphenous opening in order to ensure extraction of the upper ends of the internal and external femoral cutaneous branches. A difficulty sometimes experienced is getting the knob of the extractor to pass a valve in the lower third of the thigh, probably due to the presence of a small tributary communicating with the deep veins four inches above the patella. Less bruising occurs when the extraction is made upwards instead of downwards, probably because the tributaries break without being displaced through an angle before they rupture. The operation results in the removal—in twelve minutes—of the whole of the internal saphenous vein, with about three inches of each of its tributaries, through two small incisions. Combined with local excision of all the tributary junctions of the external and internal saphenous systems the operation is the best one for long ordinary cases if the symptoms are to be relieved for long periods. The need for an investigation by a plethysmographic method of the relationship between symptoms and the carrying capacity and retarding effects of the superficial and deep veins is urged, as also for further information as to the frequency with which duplication of the internal saphenous vein occurs.

600. Cysts in the Semilunar Cartilages.

OLLERENSHAW (*Brit. Journ. Surg.*, April, 1921) discusses the development of cysts in connexion with the external semilunar cartilage of the knee-joint, having personal experience of three cases. Clinically there is a history of injury, not necessarily severe, with gradually increasing pain and lameness, and the development of a rounded swelling over the external cartilage at the junction of its anterior and middle thirds. Varying in size from half an inch to an inch in diameter, the swelling is tense, fluctuant, and contains a clear glycerin-like fluid. The cysts are considered to be developmental in origin, due to small endothelial inclusions in the cartilage, the trauma causing irritation and distension of the spaces. The lesion in all the recorded cases has been in the external cartilage, no instance of its occurrence in the internal cartilage having yet been reported. Treatment consists in complete removal of the whole of the cyst-bearing cartilage with the cysts intact, since local removal of the cyst alone is frequently followed by recurrence. The after-progress of the author's three cases, in which complete removal with the cysts intact was performed, was uneventful, all recovering with full function and freedom from any discomfort.

601. Rectal Injection of Massive Doses of Neo-arsphenamin.

MEHRTENS (*Journ. Amer. Med. Assoc.*, February 26th, 1921), considering that in previous investigations upon the value of rectal injections of neo-arsphenamin too small doses were used, conducted experiments by gradually increasing the dose per rectum up to 4 grams of neo-arsphenamin. A brisk purge was administered the day before, and two hours before treatment the colon was flushed until the washings returned clear. Simultaneously with the injection opium was given orally or hypodermically. After dissolving and neutralizing the neo-arsphenamin in the usual way, 100 c.cm. were injected and retained, if possible, for twenty-four hours, the blood, urine, and spinal fluid being analysed for arsenic content; 160 injections were given before the maximum dose of 4 grams was reached, this dose being given in 125 cases with complete safety. It was found that arsenic was absorbed into and remained longer in the blood, and that larger quantities were eliminated in the urine, than after intravenous injections, while about equal concentrations in the spinal fluid were obtained with either method. Although intravenous administration is still the method of choice in most cases, rectal administration in massive doses is useful, especially in children, in those with difficult veins, and in those for whom intravenous injections are dangerous or undesirable.

602. Surgical Narcosis.

GOVAERTS (*Lancet*, March 12th, 1921) speaks very favourably of a method of procuring anaesthesia, described by Clere-Dandoy. An hour and a quarter before operation the patient is given a hypodermic mixture of dionin, heroin, morphine, and hyoseine hydrobromate. To produce narcosis a mixture of one part chloroform, one part ether, and half a part ethyl chloride is given. An attempt is made to show how each of the various drugs plays a part. The advantages claimed for the method are greater safety, satisfactory anaesthesia, and diminished toxic results.

OBSTETRICS AND GYNAECOLOGY.

603. Gabaston's Method for Removal of the Placenta.

ESMANN (*Hosp. Obstetrics*, March 16th, 1921) has nothing but good to say of Gabaston's method, which consists of injecting sterile saline solution into the placenta through the umbilical vein. In the course of only a couple of weeks the author encountered four cases of adherent placenta in which this method was perfectly successful, although Credé's method had been tried and had failed. In the first case the injection of only 400 c.cm. of sterile water was sufficient. In the second the placenta was not expelled until about 1,000 c.cm. had been injected, and in the last two cases about 800 c.cm. were injected. One of the patients was a 3-para, aged 30, whose last confinement in her home three years earlier had been complicated by retention of the placenta. Manual detachment had been undertaken, fever had supervened with bilateral phlebitis, and she had been confined to bed for five months. The author was therefore anxious to avoid a repetition of this misfortune. The patient had a severe cold on admission to hospital, and for some days she was febrile and showed signs of small infarcts of the lungs. But the author regards this condition as being unconnected with the adoption of Gabaston's method, and the patient was discharged in good health after confinement to bed for about three weeks. The remaining three patients were primiparae; in two cases labour was completed spontaneously, in the third it had to be hastened with forceps on account of imminent asphyxia. The puerperium in all these cases was uneventful.

604. Delivery by Version in Normal Labour.

POTTER, in a paper read to the Philadelphia Obstetrical Society (*Amer. Journ. of Obst. and Gynec.*, March, 1921), advocates the version and delivery as a breech in all normal confinements. He believes that by this unorthodox procedure he relieves the patient of much pain, and diminishes the risks of laceration and infections. In one year he performed 920 versions, 400 being primiparae, 520 multiparae, out of 1,113 deliveries. In this number there were 41 stillborn infants, and 34 children died in the hospital. The maternal mortality was two—one from colitis and one from pneumonia. In the discussion that followed, opinion varied greatly as to whether it was justifiable to teach version as a routine, but all agreed that in Potter's hands the results were as good as those obtained by any other method of delivery.

605. Opothopathy and the Menopause.

MARIE and FOURCADE (*Bull. Soc. de Théor.*, March 9th, 1921) remark that every alienist knows how dangerous the menopause is in neuropathic subjects as well as in women with renal or hepatic insufficiency. Obsessions, phobias, melancholia, acute hallucinatory confusion, and more or less systematized persecutory insanity are frequently observed in the period preceding, accompanying, and following the menopause. Marie and Fourcade are convinced that the suppression of the menstrual flow is not responsible for these symptoms, but assign the chief part to a deficiency of the endocrine glands, especially of the thyro-ovarian secretion, as maintained by Hutinel. They have therefore made a systematic use of opothopathy in all the mental disorders of the menopause. After a preliminary period devoted to a disinfection of the system, when, as is the rule, a slight hepato-renal insufficiency exists, opothopathy is instituted, consisting in all cases of thyroid and ovarian extract and supplemented by suprarenal extract or extracts of other endocrine glands in the presence of symptoms indicating their insufficiency. The histories of 8 cases are recorded, in 6 of which considerable improvement occurred, and in 2 no result was obtained from this treatment.

606. Obstetric Paralysis of the Arm.

MARAGLIANO (*La Chirurgia degli organi di Movimento*, February, 1921) controverts the views of the authors who have suggested that obstetric palsy may be caused by a lesion of the capsule of the shoulder-joint, apart from any muscular or nervous injury; the articular swelling, he believes, is a symptom of the distortion, and is always associated with lesions of the brachial plexus. In some cases muscular defects of the biceps, coraco-brachialis or brachialis anticus, are concerned in the deformity. It is never too late, Maragliano believes, to obtain some degree of improvement in the condition, however long it may have been untreated. The essential requisite is correction or hypercorrection of the deformity, with hyperabduction and external rotation at the shoulder, flexion at the elbow, and extension of the wrist, hand, and fingers. During the first few months of life an apparatus should be used which can be removed at frequent intervals for purposes of massage and toilet; in older patients the limb should be continuously immobilized for as long as twelve months.

607. Fibromyoma of the Urethra.

ACCORDING to OTTOW (*Zentralbl. f. Gynäk.*, March 12th, 1921) fibroid tumours of the female urethra are very rare, and Palm in 1901 was able to collect only 21 cases of fibroma, 4 of fibromyoma, and one of myoma. Ottow encountered a case of pediculated fibromyoma of the urethra in a multipara aged 53, who complained of a recently noticed discharge, but in whom micturition was normally performed. A hard, egg-shaped tumour, 2.7 by 2.4 by 1.8 cm., presented in front of a greatly dilated external urinary orifice; the surface of the tumour was smooth except for a narrow band of corrugations which extended sagittally over its anterior surface from the neighbourhood of the clitoris to that of the vagina. The broad pedicle, 1 cm. broad, sprang from the anterior wall of the urethra.

608. Rupture of Uterus Treated Expectantly.

VENOT and PÉRY (*La Gynéc.*, January, 1921) record the case of a woman in whom, after extraction of the foetus, a tear admitting three fingers was found in the uterus. The treatment was expectant. Few signs of shock were perceptible, and the sequelae were in every way satisfactory. ANDÉRODIAS (*Ibid.*) has had a similar experience. The authors are agreed, however, in recommending laparotomy, whenever possible, as the correct treatment for rupture.

PATHOLOGY.**609. Sedimentation Velocity of Erythrocytes during Pregnancy.**

ACCORDING to MACCABRUNI (*Ann. di Ostetricia e Ginecologia*, January, 1921), Fähræus in 1916 first noted that sedimentation of red blood cells in citrated blood occurred more rapidly in blood derived from pregnant women; the sedimentation velocity, he found, increased progressively as pregnancy advanced, and at term had become increased fourfold. The rapidity of sedimentation became increased also in certain infections and in some cases of tumour. In 1920 Linzenmeier confirmed these observations, and found that the increased velocity of sedimentation was not present before the fourth month of gestation; apart from pregnancy the phenomenon was particularly well marked in cases of pelvic cellulitis or peritonitis and of adnexal inflammations. It was also established that the diminution of sedimentation time persisted for eight months *post partum*. It is now acknowledged that the phenomenon has little diagnostic value; it is not present in the early months of pregnancy, and is of no assistance in the diagnosis between cephalic gestation and adnexal inflammations. Maccabruni claims to have discovered the cause of the sedimentation phenomenon by investigation of the corresponding specific gravity indices of the plasma. Whether taken from pregnant or non-pregnant subjects, from healthy women or from those who are the subject of various morbid processes (pelvic or located elsewhere), the red blood cells, provided they have been centrifugalized and washed in normal saline solution, exhibit exactly similar velocities of sedimentation. The cause of Fähræus's phenomenon is therefore to be found in the plasma. Further experiments showed that the variations of sedimentation velocity corresponded invariably to variations (in the inverse sense) of the specific gravity of the blood plasma. The author acknowledges that experimental alterations in the saline content, and therefore the specific gravity of the plasma, did not lead to corresponding

inverse alterations of sedimentation time, but points out that in such experiments haemolytic factors come into play. Support for his view is to be found in Zangemeister's researches in connexion with hydraemia gravidarum, and Tridonani's finding of a constant reduction in the specific gravity of the blood serum during pregnancy.

610. Sarcoma of the Stomach.

ACCORDING to KLINKERT (*Nederl. Tijdschr. v. Geneesk.*, April 2nd, 1921), who records a case in a man aged 28, sarcoma of the stomach is a rare occurrence, only one case being met with to every 200 gastric carcinomata. Haggard in 1920 collected 244 cases of gastric sarcoma, of which 107 came to operation. Two forms of gastric sarcoma are described. The first, of which Klinkert's case is an example, shows a tendency to infiltration, the whole stomach wall being invaded by the new growth. Tumours of this kind are almost always lymphosarcoma or round-celled sarcoma. They arise from the submucosa and do not involve the mucous membrane until late. This explains why haemorrhages do not occur till late, in contrast with carcinoma, which, being a malignant growth of the mucous membrane, is associated with occult haemorrhage. Symptoms of pyloric stenosis are rare in gastric sarcoma, although they happened to occur in Klinkert's case. Round-celled or lymphosarcoma of the stomach usually occurs in young persons. The prognosis is grave, even after operation, as metastasis occurs, according to Flebbe, in 40 per cent. of the cases, especially in the lymphatic glands and liver. Cases of complete recovery, however, have been recorded, and Rupert reports a case in which the patient was alive seven years after the onset. The second form of gastric sarcoma is fibrosarcoma and myosarcoma. It usually occurs late in life and is more benign in character. It may form a very large tumour, which is attached only by a pedicle to the stomach wall and is liable to cause great difficulty in diagnosis, as it has been mistaken for an ovarian cyst. The prognosis is much more favourable in these cases, complete recovery taking place in 70 per cent. according to Flebbe.

611. Primary Hypertension.

PAL (*Wien. klin. Woch.*, February 10th, 1921) distinguishes a primary permanent hypertension, due to a hypertonic condition of the muscular wall of the arteries, from secondary hypertension, which is found in certain forms of nephritis and arterio-sclerosis. The initial stage of primary hypertension is almost always free from symptoms. The heart is usually already considerably enlarged when subjective symptoms occur, such as headache, irritability, and insomnia. The etiology of the condition is unknown, but most probably there is a familial predisposition.

612. Cysts of the Anterior Mediastinum.

ACCORDING to CLERC and DUVAL (*Bull. et Mém. Soc. de Chir.*, February 15th, 1921), who record a case in which the tumour was successfully removed by the transpleural route, dermoid cysts of the anterior mediastinum may be classified as follows: (1) Retrosternal, (2) cervico-retrosternal, (3) median and lateral mediastino-thoracic, (4) lateral thoracic. Of 51 cases collected by Nandrot, 3 cysts were situated in the mediastinum and projected into one half of the thorax, 6 were cervico-mediastinal, 18 did not extend beyond the limits of the anterior mediastinum, and 24 which had mainly developed in one side of the thorax projected into the pleural cavity. From the surgical point of view, therefore, the two following varieties of cysts can be distinguished: (1) Those which can be attacked by the anterior mediastinal route only, the incision being prolonged upwards to the neck, if necessary; (2) those which can be attacked by the costal route—the most frequent variety.

613. Histological Examination of the Skin after Subcutaneous Injections of Paraffin.

VAN GELDEREN (*Nederl. Tijdschr. v. Geneesk.*, February 19th, 1921) made a histological examination of the skin of a dog which had been given eight injections of liquid paraffin, with the following results: (1) The paraffin is not absorbed by phagocytes. The vacuolated cells round the deposits of paraffin are leucocytes and fibroblasts which have undergone fatty degeneration. (2) A slight inflammatory reaction occurs in the neighbourhood of the paraffin, with considerable degeneration of connective tissue. (3) Encapsulation begins in the second week. A slight infiltration of small cells persists. Giant cells are absent. (4) Paraffin exerts a permanent irritation on the cells of the body, as is shown by fatty degeneration and the marked growth of fibroblasts.

EPITOME OF CURRENT MEDICAL LITERATURE.

MEDICINE.

614. Aneurysms of the Cystic and Splenic Arteries.

HÖGLER (*Wien. Arch. f. inn. Med.*, August 1st, 1920) records two cases of aneurysm of abdominal arteries in which, for the first time on record, a diagnosis was made during life and confirmed by the autopsy. In the first case, aneurysm of the cystic artery in a man aged 51, with rupture into the bile ducts, the diagnosis was based on the following symptoms: (1) Attacks of pain resembling biliary colic occurring on the slightest provocation and radiating to the pubic region; (2) severe intermittent gastro-intestinal haemorrhage after the attacks; (3) the auscultatory findings—namely, a systolic murmur in the region of the gall bladder at the time of the haemorrhage. In the second case, aneurysm of the splenic artery in a woman aged 61, the diagnosis was based on the following symptoms: (1) Attacks of pain in the left hypochondrium and in the back, improved by lying on the right side; (2) a pulsating tumour in the left hypochondrium; (3) a systolic murmur over this tumour; (4) the x-ray findings—which showed an extra-ventricular pulsating tumour and an ovoid shadow the size of a walnut in the region of the tumour. Höglér emphasizes the fact that the auscultatory findings were the decisive factor in the diagnosis. Although 16 cases of aneurysm of the splenic artery are on record, in none of them is any mention made of the auscultatory findings, while among the 47 reported cases of aneurysm of the hepatic artery, in only one case, which was reported by Bickhart and Schumann, was the diagnosis made during life owing to the presence of a systolic murmur over a tumour in the hepatic region, but no autopsy was made. Höglér therefore recommends that in all obscure abdominal diseases systematic auscultation of the abdomen should be carried out.

615. Hydrocephalus Complicating Cerebro-spinal Fever.

WORSTER-DROUGHT (*Journ. Neurol. and Psychopathol.*, February, 1921) points out the importance of early recognition of hydrocephalic symptoms, since speedy and repeated lumbar puncture, following the period of serum administration, will often prevent chronicity. When symptoms of internal hydrocephalus occur and no fluid follows lumbar puncture the only effective method is drainage of the subarachnoid space above the obstruction in the dorsal or cervical region, the latter being usually the more successful. As soon as the skin is penetrated the stylet should be removed in order that the cerebro-spinal fluid may escape directly the needle penetrates the subarachnoid space, thus avoiding injury to the cord. Should lumbar, dorsal, and cervical puncture all prove unsuccessful, obstruction from fibrino-purulent exudate having occurred at the foramen magnum, sphenoidal puncture may be tried before tapping the lateral ventricles. By introducing the needle at a point 2 mm. external to the supraorbital notch the most external portion of the sphenoidal fissure is reached, and on withdrawal of the stylet cerebro-spinal fluid escapes if the hydrocephalus is generalized in the cranial cavity. Failing this, drainage of the ventricles may be tried, in infants through the lateral angle of the anterior fontanelle, or in older children and adults by Keen's or Kocher's method. Instead of trephining, the author has successfully punctured through a hole drilled in the skull over Keen's point, with equally good results and less shock than after trephining. Each side should be operated upon alternately. Incision of the corpus callosum and prolonged drainage through a wide opening has been advocated, one successful case being recorded.

616. Cerebral Haemorrhage in Childhood.

CONTI (*La Pediatria*, February 15th, 1921) remarks that all writers are agreed that cerebral haemorrhage is very rare in childhood. Sclerosis of the arteries and the formation of miliary aneurysms, which are the principal anatomical factors, are absent at this age. There is thus an absence of resistance to the blood stream and of a rise of arterial blood pressure and hypertrophy of the left ventricle which occurs when the patient's general condition of nutrition renders it possible. Some writers, however, such as Simnitzky, assert that arterio-sclerosis in children is not so rare as is generally thought. Cerebral

haemorrhage appears to be more frequent in males, just as in adult life. Conti records a case in a female infant, aged 18 months, who was admitted to hospital with nephritis, probably of malarial origin, and developed left hemiplegia, preceded by convulsions, the day before death. The autopsy showed a large haemorrhage in the right cerebral hemisphere, and degeneration of the vessel walls on microscopical examination. The haemorrhage is attributed by Conti to the existence of chronic nephritis.

617. X-Ray Treatment of Acne Vulgaris.

WITHERBEE and REMER (*Med. Record*, March 19th, 1921) deprecate the use of local applications of drugs during x-ray treatment of acne vulgaris because it is essential for uniform and permanent results that the x-rays should diminish the size of the sebaceous follicles without affecting the skin and its appendages, whereas the combined effect of irritating drugs and x-rays produces a radio-dermatitis with subsequent atrophy, wrinkling, and telangiectasia. With the patient prone and the head sideways, the eyes, eyebrows, eyelashes, and the hair over the temporo-frontal region are protected with lead foil, and the tube is centred over the zygoma, and an exposure of a quarter of 1 skin unit is given weekly to each side of the face, and continued for two or three weeks after new lesions have ceased to form. Twelve to sixteen treatments constitute a regular course, and if the chest and back are involved these are treated in the same way, overlapping of exposure being avoided by protection with lead foil. Dietetic and constitutional measures should be maintained after such full course of x-ray treatment.

618. A Peculiar Fever of Infancy.

GRULEE and BONAR (*Amer. Journ. Dis. of Children*, March, 1921) record observations upon a peculiar fever of infancy, probably due to depletion of the water reserve of the body. In infants in whom the water has been depleted by persistent vomiting or by unsuitable thickened foods, a temperature is noted which appears to be due to dehydration, there being a direct relation between the temperature curve and the water intake. Careful estimates of the number of red and white cells, haemoglobin, and specific gravity of the blood, confirmed this view. Although an infectious or bacterial origin of the fever cannot be entirely eliminated, because of the possibility of the changed condition being responsible for an absorption of intestinal bacteria, most of the evidence is against such a toxæmia, since there are no accompanying toxic or gastro-intestinal symptoms, and there is evidence of a reduced water content of the blood during the febrile period. The observations have a practical bearing upon the treatment of severe vomiting conditions in infancy and on the use of thickened foods.

619. Bronchial Asthma.

ALEXANDER and PADDOCK (*Arch. Intern. Med.*, February 15th, 1921), from a study of a series of cases of bronchial asthma with a view to correlating any findings common to all, found that an outstanding feature was an almost constant sensitiveness to pilocarpine and epinephrin. While normal people gave very little or no response to half a grain of pilocarpine, vagotonic patients, with or without asthma, reacted in varying degrees. To epinephrin the majority reacted with an abnormal rise in blood pressure and signs of pallor, tremor, or even rigor, showing increased sensitiveness to the drug. Those cases which reacted excessively were found to be relieved by 0.25 c.c.m. of 1 in 1,000 of epinephrin chloride, which is a much smaller dose than that usually employed, so that the larger doses generally used may be greatly in excess of requirement, and caution is therefore urged against its promiscuous use in asthma.

620. Quinidine in Heart Disease.

JENNY (*Schweiz. med. Woch.*, March 24th, 1921) has given quinidine in 18 cases of auricular flutter associated with arrhythmia perpetua or delirium cordis. Only in one case did this remedy fail in its object. As the detailed records of his cases show, very different quantities of the drug were given to obtain the desired effect. In one case a total dose of 0.5 gram was sufficient to restore the pulse to its normal state. In this case the auricular flutter had lasted three weeks and the recovery effected was maintained over

an observation period of five months. In another case as much as 15.5 grams had to be given before the arrhythmia could be controlled. Thus, while in one case the action of the drug was demonstrable after three hours, in another its effects could not be detected till the tenth day of its administration. The dosage recommended by the author is, to begin with, 0.3 gram. The amount may be slowly increased, and as much as 2 to 3 grams may be given in the twenty-four hours. Only after ten to fourteen days' unsuccessful treatment should the inability of the drug to control the symptoms be accepted. Tinnitus and ocular disturbances are indications for discontinuing the drug at once. But, provided strict medical supervision is exercised, such symptoms as abdominal discomfort, headache, giddiness, and increased pulse rate may be ignored.

621. Treatment of Erysipelas by Injections of Novocain and Adrenaline.

NICOLAS (*Zentralbl. f. Chir.*, February 26th, 1921) employed Wehner's and Meyer's method for controlling erysipelas by injection of novocain and adrenaline into the periphery of the inflamed area in six cases. The injections were carried out with a 1 per cent. solution of novocain, or novocain and adrenaline, subcutaneously or intracutaneously. Nicolas's observations showed that this treatment was not superior to many other methods of dealing with erysipelas. In no case was the spread of the eruption arrested at the injected line, and in no case was the ordinary duration of the disease curtailed. There was also a theoretical objection to the method. Even if the peripheral advance of the erysipelatous process had been prevented by the injections, the central area would not be affected, and there was a danger of streptococci passing into the subcutaneous tissue when their advance in the cutis was held up. Nicolas concludes that the attempt to control erysipelas by injections of anaesthetics is unsuccessful.

622. The Relationship between Lethargic Encephalitis and Epidemic Hiccough.

LEMOINE (*Bull. et Mém. Soc. Méd. des Hôp. de Paris*, March 17th, 1921) remarks that several writers have drawn attention to the etiological relationship which appears to exist between lethargic encephalitis and epidemic hiccough. Economo in particular has recorded that the last epidemic of hiccough observed by him in Austria was followed in about a month's time by the appearance of myoclonic encephalitis in the same district. Similar cases were seen by other observers in the Tyrol and Italy. Lemoine himself reports the case of a man suffering from epidemic hiccough, whose brother, with whom he had been in close contact four days after the onset, developed lethargic encephalitis five days later. The close relationship between the two affections is also illustrated by DARGEIN and PLAZY (*Ibid.*), who report a case of a man, aged 42, in whom a prolonged attack of febrile hiccough was followed by typical lethargic encephalitis.

623. The Prognosis and Sequelae of Lethargic Encephalitis.

CRUCHET (*Bull. et Mém. Soc. Méd. des Hôp. de Paris*, March 17th, 1921) records the outcome of 32 cases observed by him from March, 1918, to February, 1921; 13 of these belonged to the bulbo-pontine form, 8 to the meningo-encephalitic, 7 to the mental, 2 to the convulsive, and 1 each to the hemiplegic and spinal forms. Twelve cases, or 37.5 per cent., were fatal, and of the remaining 20 the great majority developed symptoms resembling paralysis agitans, myoclonic movements, or mental symptoms. Cruchet concludes that though as regards life recovery is relatively frequent, the occurrence of grave sequelae should warrant a guarded prognosis.

624. Chlorine as a Therapeutic Agent.

HALLDORSON (*Therapeutic Gazette*, March 15th, 1921) considers that chlorine in watery solution is most useful in the treatment of diseases of the respiratory tract and lungs in children and adults alike. To give the best results the solution must be properly prepared, and, when large quantities are required, it may be made by charging distilled water from gas cylinders. Small quantities of the solution may be made by placing 40 grains of freshly ground sodium chlorate in a quart glass-stoppered bottle, adding acid. hydrochlor. ʒiij , and allowing it to stand for a minute or two until the salt is dissolved. After adding an ounce of water and shaking vigorously, water may be added in small quantities, with alternate shakings, up to 16 ounces. Care must be taken that the chemicals combine properly, or the solution will contain free hydro-

chloric acid. Chlorine solution may be given in doses of two to four teaspoonfuls in a tumbler of milk in acute tuberculosis, or with some vehicle as "palatol" in pneumonia and influenza; the effect is purely systemic, the solution apparently acting as a neutralizer of toxins.

SURGERY.

625. Hypertrophic Stenosis of the Pylorus.

RAMSAY (*Brit. Journ. of Surgery*, April, 1921) considers that Ramstedt's operation is the operation of choice in the treatment of hypertrophic stenosis of the pylorus. Medical treatment should be given a trial first, but it should not be prolonged if the vomiting is not controlled and weight is not gained, the time spent in such treatment being determined for each individual case. Surgical treatment is also indicated when the infant is so wasted and exhausted that any further loss of weight would be likely to cause death should an operation be performed later. Ramstedt's operation consists in dividing the hypertrophied muscular coat in the axis of the pyloric canal, leaving the mucous membrane intact, and without using sutures to close the gap. Through an incision $\frac{1}{2}$ in. long, extending downwards from the ensiform cartilage, the pylorus only is brought out of the wound, and is incised longitudinally on its anterior surface in the relatively bloodless area lying between the terminal branches of the vessels running along its upper and lower borders. The whole of the hypertrophied muscle layer is divided without wounding the mucous membrane which bulges freely into the gap, and the patency of the canal can be tested by gently squeezing the stomach. After-treatment consists in feeding and overcoming the marasmus, one-drachm feeds of malted milk being given every quarter of an hour as soon as the effects of the anaesthetic have passed off. The quantity and quality are gradually increased according to progress, care being taken to avoid overfeeding or sudden increase. Should any recurrence of symptoms occur and continue, a second operation should not be delayed, since such recurrence probably indicates that the constricting muscular band has been insufficiently divided.

626. Congenital Atresia and Occlusion of the Choanae.

MOURET and CAZEJUST (*Rev. de l'ot., d'otol. et de rhinol.*, March 15th and 31st, 1921) state that although this condition is fairly uncommon it is liable to be mistaken for adenoids by practitioners who are not specialists. In the adult the symptoms and signs are as follows: The complexion is pale, the mouth is half open, the teeth unsound and badly implanted, the upper lip thin and the lower lip dependent. The face is bloated and the naso-labial folds obliterated. The eyeballs are slightly prominent. The nose is thin and sharp. The nasal orifices are narrow and the entrance of the vestibule shows the presence of characteristic thick gelatinous mucus resembling the contents of mucous polypi. The voice is more or less nasal. There is loss or diminution of the sense of taste. The patient complains of a constant dryness of the mouth and throat. Occasionally there is some deafness, which is usually due to chronic middle-ear catarrh. Sleep is often disturbed by nightmares. There is a liability to violent headache, which is probably due to reflex causes or to congestion of the meninges. In the infant the symptoms vary according as the occlusion is bilateral and complete or bilateral and incomplete or only unilateral. In cases of bilateral occlusion the symptoms are very grave. If the child does not die immediately after birth, death takes place very rapidly, as it can neither breathe nor suck. In cases of incomplete occlusion the symptoms are less severe. The cyanosis and recession, which vary according to the degree of nasal permeability, increase during feeding. The child has occasional fits of suffocation and is restless in its sleep. There is more or less rapid emaciation, and sooner or later death occurs. Occlusion of the choanae must be distinguished from adenoids, enlarged turbinates, deviation of the septum, polypi, and foreign bodies, and in infants from stridulous laryngitis. Treatment is exclusively surgical, and consists in making the nasal passages as permeable as possible.

627. Paravertebral Dullness in Carcinoma of the Oesophagus.

LUGER (*Wien. klin. Woch.*, February 24th, 1921), while examining a case of carcinoma of the oesophagus, noticed on careful percussion, a bilateral area of dullness on either side of the vertebral column, which became more extensive as the disease advanced. This finding was confirmed by

subsequent examination of other cases of carcinoma of the oesophagus, and he now records thirteen examples of this disease in which a bilateral symmetrical or asymmetrical area of dullness of varying degree was found on either side of the vertebral column, corresponding to the position of the tumour. The dullness usually disappeared in the knee-elbow position, and sometimes when the patient bent forwards. Luger points out that this percussion sign can hardly be regarded as of great diagnostic significance, as carcinoma of the oesophagus can be detected early by clinical and x-ray examination, whereas this dullness is a relatively late phenomenon. Further observations, however, are required to determine whether the sign is present in deep-seated tumours of the cardiac end which require to be distinguished from spastic conditions of the oesophagus.

628. Death from Nitrous Oxide-Oxygen Anaesthesia.

BALDWIN (*Med. Record*, February 12th, 1921) calls attention to the fact that nitrous oxide-oxygen anaesthesia is not as safe as is generally thought, the death rate in Columbus being 1 per cent. of administrations for major operations, so that its use has been abandoned. Death usually takes place suddenly and without the slightest warning. From experiments carried out by Jackson upon dogs it is concluded that the cause of death in these cases may be either from central respiratory depression, excessive cardiac inhibition, or ventricular fibrillation, and while it is possible that in all cases each of these conditions is present, one or other of them predominates and is the determining factor, the character of the death varying accordingly. Further special study is urged in order to be able to guard against this danger, or lead to the abandonment of the anaesthetic if the dangers cannot be overcome.

629. The Limitations of X-Ray Treatment in Tuberculous Adenitis.

REYN (*Hospitaltidende*, March 2nd, 1921), who is one of the chief medical officers of the Finsen Institute in Copenhagen, confesses to disappointment with regard to the action of the x rays on tuberculous glands. In the course of treating several hundred cases with the x rays he has rung the changes in the technique, first using unfiltered rays and later adopting different methods of filtration. Tuberculous glands may, indeed, shrink under this treatment, but they often fail to return to normal, whereas when this treatment is supplemented by artificial light the results are infinitely better. This combination of x rays and light baths—carbon-arc lamp or quartz-mercury lamp—is undoubtedly the best treatment available, only excepting those cases in which a single, freely movable, gland can be excised. When tuberculous adenitis is complicated by abscesses and fistulae the combined treatment referred to should be supplemented by local Finsen treatment. The author enforces his indictment of the x rays by reference to a case in which partial arrest of growth of one half of the lower jaw in a child suffering from lupus was attributed to the inhibitory action of the x rays. As a result of deep x-ray treatment the author anticipates many such disconcerting surprises in cases showing no immediate reaction.

630. Congenital Torticollis.

MEYERDING (*Journ. Orthopaed. Surg.*, March, 1921) considers the etiology, diagnosis, and treatment of congenital torticollis. This condition is characterized by a painless, cord-like contraction of the sterno-mastoid muscle resulting from trauma at or preceding birth, the head being drawn towards the affected side with the chin pointing in the opposite direction, eventually producing scoliosis of the cervical spine with compensatory scoliosis in the dorso-lumbar region. Distortion of the face may result, and the muscles, fasciae, and even the vertebrae, may become deformed if the condition remains unrelieved. The painless contraction, easily felt and not tender, and not accompanied by fever, producing the characteristic deformity soon after birth, differentiates the condition from tuberculous disease of the cervical spine. Treatment is essentially surgical, all contracted structures being divided, the deformity over-corrected, and the new position maintained by means of plaster casts. Subcutaneous tenotomy is to be avoided, the contracted structures being freely exposed and divided through an incision just above and parallel to the sternal end of the clavicle. Fixation in a position of over-correction is necessary for from one to three months, according to the degree of the deformity to be overcome, and in order to prevent the possibility of any tendency for the scar to reproduce the deformity by

contracting. In all cases a window should be left over the trachea. Treatment should be undertaken as early as possible in order to prevent the deformity becoming permanent.

631. Permanganate of Silver in the Treatment of Urinary Disease.

GALLOIS (*B. M. Soc. de Trin.*, March 9th, 1921) draws attention to the greater efficacy of permanganate of silver as compared with the potassium salt in the treatment of urinary disease. The doses used were 0.05 gram or 0.10 gram per litre for gonorrhoea and cystitis. The only disadvantage of permanganate of silver is that it is slightly more caustic than permanganate of potash. The pain, however, is not very persistent and lasts only a few minutes.

OBSTETRICS AND GYNAECOLOGY.

632. Placental Retention.

ACCORDING to VERMELIN (*Revue Méd. de l'Est*, March, 1921) the pathogenesis of retention of a placental cotyledon, when not due to unskilful delivery, may be traced (1) to irregular or insufficient uterine contractions, (2) to local abnormalities of the uterine mucosa, or (3) to placental changes, localized or general, of which fibrous infiltration and diffuse syphilitic softening are those most frequently encountered. Retention should be suspected in those cases particularly in which the third stage has been protracted and accompanied by excessive haemorrhage, and in which the maternal surface of the placenta is unduly rough and exhibits deep sulci between the cotyledons. In a certain number of cases the most skilled observer may remain in doubt as to whether retention has occurred. A cotyledon retained in the region of the uterine cornu leads to marked thinning of the myometrium (for example, to 1 mm. only) at the region of implantation; a cotyledon retained in the lower uterine segment becomes pediculated, presenting in a widely dilated os externum; retention of a cotyledon in the intermedial zone is followed by subinvolution with persistent slight dilatation of the os. The eventual sequelae may consist in (1) spontaneous expulsion; (2) infection—uterine, pelvic, or general; (3) retention with little or no infection, but grave and protracted haemorrhages; (4) in rare instances the occurrence of chorio-epithelioma malignum. With regard to treatment, Vermelin recommends manual exploration of the uterus and removal of the retained cotyledon in cases which are seen immediately after or within a few hours of labour. When the medical man is called to the case some days after labour, a digital examination, preceded if necessary by dilatation of the cervix by means of a tent or Hegar's instruments, and accompanied by a bacteriological test, should be made; where such a test shows the presence of a streptococcus, particularly a haemolytic streptococcus, the author holds that curettage and even digital tearing through the protective leucocyte barrier are equally contra-indicated—recourse should be had to hysterectomy. In non-streptococcal cases of prolonged placental retention curettage should be conducted with special care on account of the possibility of extreme attenuation of the uterine wall.

633. Pregnancy and Cardiac Insufficiency.

ACCORDING to AZA (*Medicina Ibera*, No. 178, 1921), while pregnancy in itself cannot lead to cardiac insufficiency, it may aggravate pre-existing cardiac affections, or in cases of morbid conditions caused by gestation may cause such affections to occur *de novo*. Pre-existing cardiac affections may be aggravated indirectly by the increased work demanded of the heart, or directly by elevation of the diaphragm and pressure of the stomach against the heart. The added cardiac impairment may be brought about gradually during pregnancy or suddenly by the strain of labour; in labour may also be produced a cardiac embolus, which is to be distinguished from the septic emboli associated with thrombo-phlebitis in the puerperium. Sudden death occurring *post partum* may be due in certain cases to the increased filling of the thoracic veins which follows the descent of the diaphragm. A case is related of syncope occurring early in the fourth labour of a subject of mitral insufficiency; the vascular conditions contra-indicated treatment by pituitary extract and *accouchement forcé* in the patient's state was not possible. Delivery was obtained by vaginal Caesarean section; the post-operative course was normal.

634. Heart Disease in Pregnancy and Puerperium.

LEMY SOLAR (*Journ. de Méd. et de Chir.*, February, 1921) has investigated the 207 cases of interruption of pregnancy in the fourth to the seventh month observed at the maternity department of the Rigshospital in Copenhagen between August, 1910, and July, 1918. As many as 37.5 per cent. of the patients were between 20 and 24 years old, and only 2 per cent. were over 40. A record of previous abortions was obtained in 14 per cent. In 49 per cent. the women were primiparae, and in 25 per cent. 2-parae. In 48 per cent. no reason could be found for the interruption of pregnancy, and doubtless among these cases were several of criminal abortion. In no fewer than 47 cases, or 22.5 per cent. of the total, syphilis was found in the mother, fetus, or both. Nephritis was present in 18 cases (8.7 per cent.), and in four it was severe. In 19 cases (9 per cent.) there was a history of trauma or over-exertion. Placenta praevia was found in 8 cases, and in 22 cases such causes as early detachment of the placenta, degeneration of the placenta, heart disease, pulmonary tuberculosis, and other factors were to blame. In no fewer than 13 cases a twin pregnancy may have prevented the mother going to term.

635. The Causes of Abortion and Premature Labour.

TRIER (*Hospitalstidende*, March 30th and April 6th, 1921) has investigated the 207 cases of interruption of pregnancy in the fourth to the seventh month observed at the maternity department of the Rigshospital in Copenhagen between August, 1910, and July, 1918. As many as 37.5 per cent. of the patients were between 20 and 24 years old, and only 2 per cent. were over 40. A record of previous abortions was obtained in 14 per cent. In 49 per cent. the women were primiparae, and in 25 per cent. 2-parae. In 48 per cent. no reason could be found for the interruption of pregnancy, and doubtless among these cases were several of criminal abortion. In no fewer than 47 cases, or 22.5 per cent. of the total, syphilis was found in the mother, fetus, or both. Nephritis was present in 18 cases (8.7 per cent.), and in four it was severe. In 19 cases (9 per cent.) there was a history of trauma or over-exertion. Placenta praevia was found in 8 cases, and in 22 cases such causes as early detachment of the placenta, degeneration of the placenta, heart disease, pulmonary tuberculosis, and other factors were to blame. In no fewer than 13 cases a twin pregnancy may have prevented the mother going to term.

636. Sterilization of Ovaries by X Ray.

BÉCLÈRE (*Journ. de Radiol. et d'Electrol.*, February, 1921) compares the method of sterilization of ovaries at one sitting with the method of weekly sittings extending over five or six weeks. The advantage of the former is for cases where, at all costs, further haemorrhage must be prevented. It is not, however, certain to cause immediate cessation of menstruation, and there are certain after-effects—nausea, etc.—which last for several days. He prefers the second method, which seldom needs more than ten sittings of twenty minutes' duration.

PATHOLOGY.**637. Experimental Production of Gastric Ulcer.**

KEPPICH (*Wien. klin. Woch.*, March 17th, 1921) conducted experiments on 26 rabbits to determine whether faradization of the vagi would produce gastric ulcer. The vagi were exposed by a median laparotomy under light ether anaesthesia. Twelve of the animals survived the operation only a short time, and died before faradization could be employed. In these cases small suffusions were constantly found in the gastric mucosa of the fundus, but no ulcers were seen. Of the remaining 14 cases 3 had to be excluded, as the electrodes broke after the vagi had been faradized for only a few days, the animals being killed on the sixth, eleventh, and eighteenth days of the experiment. No changes in these cases were found in the stomach. In 10 of the other 11 cases ulcer formation developed. In 5 cases in which both vagi were faradized the ulcers were always of a well marked chronic character. Of the other 6 cases, in which only one vagus was faradized, in 3 the ulcer was of a chronic character, in 2 it was less marked, and in one there was no ulcer at all. Microscopical examination showed the typical appearances of chronic gastric ulcer, with small-celled infiltration and increase of connective tissue. Histological examination of the faradized nerves showed feeble staining of the vagi, indicating degeneration. Keppich has also made experiments on dogs. In one case an ulcer developed in the middle of the lesser curvature after experiments for seventy-four

days, and in another case after thirty-eight days, close to the pylorus and also in the lesser curvature. All these experiments agree with observations made on the human subject in which gastric ulcer is associated with degenerative changes in the vagus. In some of these cases signs of vagus irritation had been present some time before the gastric symptoms developed. The association between gastric ulcer and changes in the vagus has thus been found in man, and has also been demonstrated experimentally. STROENK (*Wien. klin. Woch.*, March 10th, 1921) records the case of a man operated on for gastric ulcer of eighteen months' duration in whom the condition of the nerves in the region of the ulcer presented the appearance of an amputation neuroma.

638. Histological Changes in Chronic Uterine Inversion.

VASSALLO (*Annali di Ostetricia e Ginecol.*, January, 1921) describes the microscopical appearances found in the uterus of a 2-para aged 23, at the time of its removal after four months' inversion. The mucosa showed a flattening of the epithelium, which in many places had assumed a squamous character, but still consisted of one layer only; the glands were diminished in number and in many instances dilated; the connective tissue showed much cellular infiltration, chiefly with mononuclears; the blood vessels were increased in number, with a considerable degree of perivascular infiltration, and in certain regions the disposition of the vessels recalled that of granulation tissue. The muscular layer showed enlargement of the muscle cells, which contained rod-shaped nuclei, and there was much proliferation of the connective tissue, which in places exhibited hyaline degeneration and, especially in the neighbourhood of the arteries, contained numerous elastic fibres.

639. Fragilitas Ossium.

BOLTEN (*Nederl. Tijdschr. v. Geneesk.*, February 19th, 1921) records four cases of fragilitas ossium in patients aged 15, 11, 13 and 3½ years respectively, who all presented abnormally brittle bones, blue sclerotics, deficiency of calcium in the long bones as shown by x-ray examination, a large number of vasomotor disturbances, such as acrocyanosis, white spots on the nails, defects of enamel, thinness of hair on the scalp, loss of hair, urticaria, migraine, and angioneurotic oedema, and lastly, a special form of galvanic hyperexcitability. Bolten regards all these phenomena as a group of metabolic disturbances depending on insufficiency of the thymus and parathyroids, together with a slight degree of hypothyroidism. The insufficiency of the thyroid and parathyroid causes trophic disturbances in the skeleton, the osteoblasts become weaker and less numerous than normally, and the amount of calcium in the bone is much too small, thus giving rise to fragilitas ossium. The blue colour of the sclerotics is due not to an accumulation of pigment but to unusual thinness of this part of the eyeball. The galvanic hyperexcitability is a parathyroid and thymus manifestation, and the vasomotor disturbances are the result of a slight functional vasomotor deficiency due to impaired function of the glands of internal secretion.

640. Oesophago-tracheal Fistulae.

ACCORDING to GOT (*Rev. de Lar., d'otol., et de rhinol.*, April 15th, 1921) oesophago-tracheal fistulae may be classified as follows: (1) Congenital fistulae. In almost all the cases reported the middle third of the oesophagus was absent. The upper third ended in a cul-de-sac and the lower segment opened into the trachea. In such cases the infant does not survive more than a few days. (2) Fistulae due to tuberculosis, syphilis, and cancer, which form the largest group. Tuberculosis of the trachea, and much less frequently of the oesophagus, may sometimes give rise to fistulae. It is much more common, on the other hand, for perforation of the oesophagus or trachea, or of both, at once to occur owing to the discharge into their lumen of the contents of neighbouring caseating glands. Tertiary syphilis may attack the trachea and oesophagus separately, but is rarely localized in this part of the alimentary canal, apart from cases where the starting point is in the larynx or more frequently in the pharynx. Only a few examples of tracheo-oesophageal fistulae due to this cause have been reported, to which Got adds a personal case. On the other hand, these fistulae are very common in cancer of the oesophagus, being found, according to Mackenzie, in 33 per cent. of the cases. (3) Rare forms of fistulae, which include those due to trauma, rupture of an aortic aneurysm, and perforation of a neighbouring localized inflammatory process.

EPITOME OF CURRENT MEDICAL LITERATURE.

MEDICINE.

641. The Starvation Treatment of Diabetes.

MOTZFELDT (*Norsk Mag. for Lægevidenskaben*, April, 1921) has compared the results achieved at his hospital in the treatment of diabetes by fasting, as practised by Allen and other Americans, with the results of less stringent dietetic measures. His verdict is emphatically in favour of the starvation treatment. Under the old régime 54 cases were treated between 1912 and 1917, the average age being 44 years. Under the starvation régime he treated 77 cases between 1917 and 1920, the average age being 36 years, and the proportion of severe cases comparatively high. Yet the results were far better in the latter period. As a table shows, only 44 per cent. of the first class were discharged from hospital without glycosuria and ketonuria, whereas this result was achieved in 79 per cent. of the latter class. In this class only 5 per cent. died in diabetic coma, as compared with 13 per cent. in the earlier period. As the author's illustrative cases show, the starvation treatment can effect recoveries in cases of juvenile diabetes which a few years ago would have inevitably been regarded as doomed to an early death. While children and young adults tolerate the fasting diet well, great care should be exercised in cutting down the diet of elderly patients and of fat persons, who, by rapid oxidation of their own fat, are apt to suffer from ketonuria.

642. Can the Diabetic be Allowed to Lose Flesh?

RATHERY (*Bull. Soc. de Thér.*, March 9th, 1921) answers this question as follows: Loss of flesh in diabetes may be allowed provided the patient is fat and a large eater and the loss of flesh is confined within certain limits. He may also be allowed to lose flesh temporarily as the result of a relative or absolute starvation regimen. With these exceptions, a diabetic patient should not be allowed to grow thin. Loss of flesh due to dietetic errors can easily be corrected. Lastly, the loss of flesh may be pathological, indicating either a more or less latent tuberculosis or some serious disturbance in the carbohydrate metabolism.

643. Pseudo-leukaemic Splenic Anaemia in Infants.

MANCINI (*Riv. Osped.*, January 15th, 1921) records three cases (two of them twins) of this disease, in children aged 2 years and 18 months respectively. In the first case there was evidence of syphilis, rickets, and dyspepsia—in the twins rickets was the only predisposing condition present. These patients have many of the symptoms of pernicious anaemia, but the blood differs by the presence of leucocytosis (and the greater the number of leucocytes the worse the patient) and in the low globular index, without any marked diminution in the red corpuscles. Although the number of red corpuscles is usually low (1 to 2 million) in this disease, there is a high percentage of nucleated red corpuscles; the leucocytes average 20,000 and neutrophils predominate. The state of the blood may remain unchanged for months or years, and the prognosis does not depend on the state of the blood. Some children improve remarkably under arsenic or change of surroundings, but the majority die of some intercurrent affection. Pseudo-leukaemic anaemia is distinguished from true leukaemia by the scanty presence or absence of eosinophile and mast cells, and the liver increases relatively less than the spleen. The disease is never seen after the third year, symptoms may appear at six months, both sexes are equally affected, there is no evidence of heredity but a family tendency may be seen—for example, brothers, especially twins, may develop it. Usually there is marked rickets. The spleen reaches the umbilicus, is hard and painless, and easily movable; the lymphatic glands are, as a rule, not enlarged to any extent.

644. Pleurisy with Effusion on the "Sound" Side in Artificial Pneumothorax.

DE REYNIER and ROSSEL (*Rev. méd. Suisse rom.*, March, 1921) state that though effusion on the affected side is excessively common in the course of treatment by artificial pneumothorax, effusion on the sound side is very rare, only two cases having hitherto been published by Als and Süssdorf respectively. The writers record two more cases

of this kind in which, like the two cases mentioned, recovery took place and the treatment by artificial pneumothorax could be continued. The writers come to the following conclusions: (1) Effusion on the "sound" side in artificial pneumothorax is a complication independent of the treatment and must be regarded as an ordinary infective pleurisy, probably of tuberculous origin. (2) The appearance of an effusion on the opposite side to the pneumothorax is a grave but not necessarily fatal complication, in spite of the considerable diminution of the respiratory area. (3) The evolution of these pleurisies is identical with that of ordinary pleurisies. In the writers' two cases the absorption of the effusion was complete in three months, and in neither case did the subjacent lung tissue suffer. (4) Treatment, as in ordinary pleurisy, must be symptomatic at first. If the dyspnoea is very intense, the effusion must be evacuated, and owing to the other lung being out of action operation will be required earlier than in ordinary pleurisy with effusion. If there is at the same time hydropneumothorax on the side treated by insufflation, this side should be evacuated first, and the fluid replaced by nitrogen. But if there is only a very small effusion, no treatment is required, and the insufflation should only be resumed when the acute stage of the pleurisy on the opposite side has subsided.

645. The Duration of Artificial Pneumothorax.

JAQUEROD (*Rev. méd. Suisse rom.*, March, 1921) states that in a large number of cases the question of how long an artificial pneumothorax should be maintained is decided by itself, the lung, as the result of a pleural effusion, resuming its place in the thorax, or the thorax becoming filled up by fibrinous deposit without it being possible to prevent this occurrence. Among 22 cases of this kind Jaquerod saw the tuberculous process assume a more or less rapid course after absorption of the effusion in 12, in 5 its course was slightly delayed, in 3 there was considerable improvement, which was maintained for three or four years, and in 2 apparent recovery took place. But when no effusion occurs, or when the pleural cavity remains free after absorption of the effusion, Jaquerod considers it advisable to keep up the artificial pneumothorax indefinitely to prevent relapses, and sometimes throughout the patient's lifetime.

646. Artificial Pneumothorax in Bilateral Tuberculosis.

CASSINIS (*Il Policlinico*, Sez. Prat., April 25th, 1921) has performed artificial pneumothorax in 52 cases of pulmonary tuberculosis, which he classifies into the three following groups: (1) Cases of unilateral tuberculosis with lesions of varying degree; (2) cases of bilateral tuberculosis with slight and early lesions on the opposite side to the pneumothorax; (3) cases of bilateral tuberculosis with extensive but not very far advanced lesions on the opposite side to the pneumothorax. In 24 cases the pneumothorax had to be discontinued—in 12 on account of pleural adhesions; in 5 for a large pleural effusion; in 5 for anaemia; in one for cardio-gastric disturbance, and in one for haemoptysis. In 11 cases of unilateral tuberculosis the results were so good that a complete cure could be expected, and in 17 cases of bilateral disease, so far from there being any sign of aggravation, there was evidence of improvements, in patients both of the second and third groups. Cassinis, therefore, concludes that artificial pneumothorax is of undoubted value in bilateral pulmonary tuberculosis.

647. Singer's Thirst Cure for Bronchiectasis.

VOGELIUS (*Hospitalstidende*, March 23rd, 1921) and TOLDERLUND (*Ibid.*, April 6th, 1921) record cases in which Singer's system of cutting down the fluid intake to a minimum proved remarkably beneficial in relieving the symptoms of bronchiectasis. Vogelius's patient was a man, aged 63, who suffered from bronchiectasis, foetid bronchitis, and anaemia. There were no crystals, spirals, nor tubercle bacilli in the sputum, which amounted to 200 to 500 c.cm. in the twenty-four hours. After three weeks' futile treatment in hospital with expectorants, codeine, and Quimeke's postural treatment, his fluid intake was reduced, and after three weeks his sputum amounted only to 75 c.cm. Within two months of this treatment the sputum was reduced to only a few pieces. He gained 10 kilos in weight, and when he was discharged he had

ceased to expectorate and felt perfectly well. Tolderlund's patient was a woman, aged 38, whose foetid mucopurulent sputum had persisted for a long time in spite of medicinal treatment. She was subject to bouts of fever, and was dyspnoic, thin, and pale. After a month's treatment in hospital under Singer's régime the sputum was reduced from 300-400 c.cm. to 50-60 c.cm. Coincident with this reduction of the sputum there was a marked change for the better in her general condition, and she gained 6 kilos. During the following years she found it necessary to repeat this cure in her home three or four times a year whenever the sputum became profuse and foetid. When last seen she was fit for work, and her general condition was comparatively good.

648. Non-tuberculous Inflammation of the Bronchial Glands.

GÄHWYLER (*Schweiz. med. Woch.*, April 7th, 1921) criticizes the fashionable tendency to diagnose tuberculosis of the bronchial lymphatic glands on the strength of x-ray findings and certain physical chest signs. He records in detail seven cases (five children and two adults) observed during one winter in Arosa. The clinical picture conformed closely with that of early tuberculosis; the patients were easily tired and complained of pain between the scapulae and in the sternum, as well as of dyspepsia. In some cases the temperature was subfebrile and in others there was a troublesome cough with signs of chronic bronchial catarrh. Paravertebral areas of dullness, harsh inspiration, prolonged expiration, rhonchi, pectoriloquy, and other signs combined with dense hilus shadows seemed to leave at first sight little doubt as to the diagnosis of tuberculosis of the bronchial glands. But the sputum never contained tubercle bacilli, and cutaneous, intracutaneous, and subcutaneous tuberculin tests were invariably negative, even when such a heroic dose as 10 mg. of old tuberculin was given. The author insists that the diagnosis of non-tuberculous inflammation of the bronchial glands stands or falls by the tuberculin test, and as this is often positive in the absence of tuberculosis of the bronchial glands, it follows that there must be many more cases of non-tuberculous inflammation of the bronchial glands than can be demonstrated as such. The whole tenor of the author's paper is protestant against committing the diagnosis of intrathoracic lesions to the unsupported evidence of the radiographer.

649. Occupational Dermatitis in Dentists.

LANE (*Arch. of Derm. and Syph.*, March, 1921) records three cases of dermatitis in dentists due to procain—a local anaesthetic closely allied to novocain. The eruption was circinate and erythematous, with a tendency to the development of fissures affecting the fingers and palms. Where the solution had inadvertently touched the face a pronounced reaction was seen. Skin tests with a solution of procain showed a marked individual susceptibility in each case. The treatment is obviously the wearing of rubber gloves in susceptible cases.

SURGERY.

650. Indications for Operation in Gastric Ulcer.

ACCORDING to SCHÖNFELD (*Nederl. Tijdschr. v. Geneesk.*, April 9th, 1921) the indications for surgical interference in gastric ulcer are as follows: (1) In obstruction of the gastric contents as the result of pyloric stenosis or hour-glass contraction, as soon as persistent symptoms arise which prove refractory to any other kind of treatment. (2) In perigastritis with adhesion of the stomach to neighbouring organs operation is the only method of treatment. The diagnosis of adhesions has been facilitated in recent years by radiographic methods with insufflation of oxygen or sterile air into the abdominal cavity. (3) Persistent hyperacidity, especially when associated with dilatation of the stomach and weakness of the gastric wall. Gastro-enterostomy, he states, is the operation of choice in these cases. Section of the branches of the vagus in the neighbourhood of the cardia has recently been recommended, as the hypersecretion and motor disturbances have been attributed to vagotonia.

651. Implantation of the Ureter Into the Bowel.

ACCORDING to COFFEY (*Surg., Gynec., and Obstet.*, May, 1921) the essential mechanical principle necessary for successful implantation of the ureter into the intestine is that before entering the lumen of the intestine the ureter shall be made to run for some distance immediately under the loose mucous membrane. In animal experiments the

author noticed that direct implantation of the common bile duct or of the urinary duct into the intestine was followed by very considerable dilatation of the duct concerned, and in the case of the ureter by destruction of the kidney. The dilatation of the duct is to be ascribed to the static intra-intestinal pressure; consideration of the course taken in natural circumstances by the bile duct in its passage through the wall of the duodenum led to the surmise (afterwards verified experimentally) that by giving the implanted duct a submucous course immediately before its new termination, the intra-intestinal pressure would be brought to bear on the near side of the implantation opening and retrograde dilatation of the duct would thus be prevented. Using his modifications of Coffey's technique, Mayo had 22 successful results in 26 operations. Coffey records four cases in which six ureters were implanted with subsequent good function.

652. Statistics of Gastric and Duodenal Ulcer.

EISELSBERG (*Wien. klin. Woch.*, March 10th, 1921) gives the following statistics of the operations for gastric and duodenal ulcer performed in his clinic since 1918. (a) Operations for uncomplicated cases: Gastro-enterostomy, 42 cases with 1 death; exclusion of the pylorus, 9 cases with 1 death; resection and exclusion of pylorus, 28 cases with 1 death; transverse gastric resection, 38 cases with 2 deaths; Billroth's first operation, 79 cases with 2 deaths; Billroth's second operation, 164 cases with 9 deaths—a total of 301 resections with 13 deaths, or a mortality of 4.3 per cent. (b) Operations for complicated cases: 11 cases of gastric perforation with 4 deaths; 5 cases of acute haemorrhage with 3 deaths; 12 cases of jejunal peptic ulcer with 3 deaths; 7 cases of secondary operation owing to relapse or failure of first operation, with 2 deaths.

653. Gastric Syphills.

ACCORDING to FOWLER (*Surg., Gynec. and Obstet.*, May, 1921), who reports a case of benign, non-specific ulcer occurring in the stomach of a female syphilitic subject aged 26, organic syphilis of the stomach is less infrequent than was formerly supposed. The gross lesions are diffuse infiltration, or gummata progressing to ulceration. At operation, syphilitic gastric ulcers are found to be multiple and ragged, occurring usually in the region of the cardia, pylorus, or lesser curvature; often they are accompanied by perigastric adhesions and by thickening and deformity of the wall of the stomach. Microscopically there is characteristic syphilitic endarteritis obliterans, with perithelial lymphocytic infiltration; the mucosa is atrophic and the other coats are hypertrophic. Symptomatically, syphilitic differ from benign ulcers in the absence of relief from taking of food or alkalis, in the preservation of good appetite associated with vomiting, and in the result of the therapeutic test. Large gummatous masses or cicatricial contractions following extensive ulceration simulate carcinoma as regards the clinical history of the findings made at x-ray examination and at operation.

654. Syphilitic Mastitis.

BURNIER (*Paris méd.*, April 9th, 1921) suggests that syphilitic mastitis is more frequent than is generally supposed. A study of the literature shows that it may develop at all stages of acquired syphilis, and even in the inherited disease, the dates of its appearance varying from the second week to the thirty-second year. Burnier has collected 9 cases occurring in the early secondary stage, 8 in the late secondary stage, 10 in tertiary syphilis, and 3 in the inherited disease. Owing to the physiological activity of the gland it is a little more common in women (19 cases) than in men (10 cases). Pregnancy, however, does not appear to favour its appearance, only one example of its occurrence in pregnancy having been recorded. It is usually unilateral (21 out of 32 cases). Clinically two distinct forms are encountered. There may be a distinct infiltration affecting one or more lobes of the gland, and the breast is enlarged to twice or three times its ordinary size. The swelling, which is firm and sometimes of a board-like consistency, gradually merges into the healthy glandular tissue. Its size varies from that of a hazel nut to that of an orange. In other cases, in place of a diffuse infiltration there are distinct circumscribed nodules, usually six to eight in number, but sometimes single. The skin usually preserves its normal colour, but sometimes it is reddened when the tumour is adherent to it. The mastitis may assume an acute course and end in suppuration, but usually it becomes completely absorbed as the result of specific treatment. The axillary glands often escape, but may become involved in some cases. The

Diagnosis between syphilitic mastitis and cancer of the breast may be very difficult. The diagnosis in such cases is established by an inquiry into the history, the investigation of concomitant syphilitic lesions, the Wassermann reaction, and the result of specific treatment.

655. Malformations of the Anus.

DRUECK (*Med. Record*, April 2nd, 1921) considers malformations of the anus under five divisions: (1) Entire absence, from failure of the proctoderm to invaginate; (2) abnormal narrowing; (3) occlusion, partial and complete; (4) abnormal opening upon the skin; (5) opening into the vulva, perineum, or scrotum. In entire absence of the anus external skin markings bear no relation to the point of termination of the rectum above, and therefore a careful perineal dissection is required. Symptoms of acute intestinal obstruction develop in a couple of days, the absence of meconium being followed by restlessness, abdominal distension, cyanosis, and eventually faecal vomiting. In narrowing of the anus the canal is constricted at some part between the rectum and the anal opening, or such narrowing may extend the whole of the length. Some individuals go through life with partial occlusion, merely complaining of constipation. Diagnosis is difficult because liquid faeces and gas are passed, and it is only later, when the faeces are formed, that any disturbance is noticed. Membranous occlusion consists of a diaphragm across the canal, and may be complete or partial, the latter being frequently met with. When complete the diaphragm resembles the hymen, and is thin and flexible, bulging with meconium if the rectum is normal above.

656. Vertebral Osteomalacia.

EISLER and HAAS (*Wien. klin. Woch.*, February 10th, 1921) describe a form of osteomalacia affecting the vertebral column, of which a large number of cases have recently occurred in Vienna. The disease usually affects both sexes equally, and is most frequent in middle life. It starts with pain in the back, especially in the sacral region. In some cases the pain affects the whole of the vertebral column and radiates like neuralgia or sciatica. The patients all agree that the pain is particularly violent on rising from the sitting posture. In an advanced stage the patients complain of prostration, tremors in the legs, inability to work, and insomnia. Sitting down is avoided as far as possible, as this position causes an increase of pain in the back and sacrum. Intense pain also occurs in the recumbent position, especially in changing from one side to another. Finally, the patients are unable to stand or walk, and become bedridden. The symptoms at first are always regarded as manifestations of rheumatism or neuralgia, and it is only after various bath cures and physical therapy have proved unsuccessful that a vertebral affection is suspected. On examination a moderate total kyphosis of the vertebral column is found, with tenderness on pressure, of varying localization, but most marked in the sacral region. Passive movements of the vertebral column are limited in all directions. Active movements, especially bowing, cause severe pain. X rays show more or less deficiency of calcium, with consequent deformity in the bodies of the vertebrae, according to the severity of the case. Treatment consists in the administration of increasing doses of phosphorus, combined in severe cases with orthopaedic appliances, such as a plaster-of-Paris jacket or a corset. Good results are also said to have been obtained from the use of the quartz lamp.

657. Oesophageal Stricture treated by Continuous Dilatation.

MOSSAJO (*La Cronica Med. and Arch. de Med., Cirug. y Especialidad*, March 1st, 1921) records the case of a man of 24 in whom, a few days after the swallowing of caustic potash, an oesophageal stricture prevented the swallowing of all but a little liquid food. Senn's gastrostomy having been performed, he was fed through the catheter for one month, and then made to swallow a bullet, to which a silk thread had been attached. The bullet having been located in the stomach by means of Brüning's oesophagoscope, a very fine rubber sound was fixed to one end of the thread; by pulling on the other the sound was introduced within the strictured area, where it was allowed to remain for thirty minutes on the first day and for increasing periods of time on the successive days when the manoeuvre was repeated. In two months it was possible to introduce a bougie of normal calibre, which was left *in situ* for twelve hours. Normal conditions were restored at the end of three months' treatment.

OBSTETRICS AND GYNAECOLOGY.

658. Auricular Flutter and Fibrillation in Pregnancy.

THOMAS (*Journ. Amer. Med. Assoc.*, April 30th, 1920) states that he has been unable to find any record in the literature of cases of cardiac arrhythmias in pregnancy. In reporting a case attended in the Presbyterian Hospital, New York, he calls attention to the possibility of successful treatment of certain types of tachycardia that threaten the lives of pregnant women. The electrocardiographic diagnosis was auricular flutter with 2:1 heart-block; the patient was six months pregnant, and was semi-comatose, with much dyspnoea, orthopnoea, and cyanosis of the lips. The heart rate was about 180 and regular; a short, rough systolic murmur could be heard at the apex, transmitted for a short distance into the left axilla. The pulse was very feeble and thready, and could not be counted with accuracy, but was approximately 180 and regular. The blood pressure was not readable. The patient was given an initial dose of 1 c.cm. of a digitalis preparation intravenously, followed by the same dose given intramuscularly every four hours. On the next morning, while the patient was being examined, her heart rate dropped suddenly from 165 to 112, becoming at the same time quite irregular. The electrocardiogram at this time showed auricular fibrillation. The patient had received up to this point the equivalent of 105 minims of tincture of digitalis in a period of twenty-four hours. Her dyspnoea was less marked, cyanosis had vanished, and she appeared much brighter. The improvement continued, but on the twenty-second day the electrocardiogram showed characteristic auricular fibrillation. At the seventh month she was delivered of a dead foetus, weighing 5½ lb. The labour was uncomplicated and conducted without an anaesthetic. At no time did the heart rate exceed 105. The patient left the hospital with instructions to take 15 minims of tincture of digitalis three times a day. When last seen, six months later, her condition was excellent, she was doing light housework without discomfort, and had dyspnoea only after considerable exertion. The rate of the apex beat was 100; it was most irregular, and the pulse rate was 76.

659. Accidental Haemorrhage.

THIRTY-FOUR cases of premature detachment of the normally situated placenta (accidental haemorrhage), with histological examination, formed the basis of a communication to the Vienna Obstetrical Society by FRANKL and HIESS (*Zentralbl. f. Gynäk.*, April 23rd, 1921). Inflammatory or degenerative alterations of the decidua, endometrium or myometrium, according to these authors, play no part in the etiology; placental detachment in the third stage of labour being attributed to effusion of blood into the spongy tissue of the placenta, accidental haemorrhage is regarded as due to any cause or combination of causes which brings about prematurely hyperaemia in this region. Such causes may be (1) mechanical—too short an umbilical cord, for example, or traction on the membranes during protracted labour; (2) premature dilatation of the placental vessels induced, for example, by rupture of the membranes in cases of hydramnios, by birth of a first twin, by alterations in blood pressure following trauma, or by maternal circulatory disturbances, as in exophthalmic goitre; (3) abnormal permeability or friability of the placental tissue, in cases of chronic nephritis or nephropathy. It is not possible to lay down standard lines of treatment; regard must be had not only to the general condition of the patient, but also to the degree of cervical dilatation present at the moment of placental detachment. Rupture of the membranes, sometimes useful, may in certain cases be dangerous; it has therapeutic value in cases only of partial and marginal detachment. In the occasional cases in which the accidental haemorrhage coincides with transverse presentation or contracted pelvis, the treatment must be adapted to the coexisting complication. Vaginal Caesarean section may be performed in cases occurring early in or previous to labour; vaginal hysterectomy may be carried out when there is a considerable degree of uterine atony. Frankl and Hieiss have found, however, that the use of the vaginal route for operation is subject to the significant drawback that intraperitoneal haemorrhages (free or circumscribed) may be overlooked; laparotomy followed by Caesarean section or hysterectomy is therefore often preferable. Total extirpation of the unopened uterus is recommended in every case in which the uterus is greatly stretched and thinned, or its wall noticeably infiltrated with blood; in

such cases, conservation of the uterus carries with it the risk of subsequent atony with severe bleeding or other complications in the early or late puerperium.

660. Acute Inversion of Uterus.

HUNTINGTON (*Boston Med. and Surg. Journ.*, April 14th, 1921), in discussing the etiology of acute puerperal inversion of the uterus, considers that the insertion of the placenta in or near the fundus is the main underlying factor, since the extreme rarity of the condition coincides with the rarity of such placental implantation, and the frequency with which forcible expression is used points to this factor as having very little to do with its causation. Symptomatically profound shock, excessive haemorrhage, and severe pain may be present, though any or all of these symptoms may be absent, a valuable diagnostic sign being the absence of any uterine mass to be felt through the abdominal wall. In cases where there is any shock or undue bleeding, and the typical spherical mass behind which the hand can easily pass cannot be felt through the abdominal wall, a vaginal examination should be made. The characteristic feature of being able to pass the hand behind the mass and grasp the fundus in the hollow of the hand is most important. If diagnosed early the mass can be pushed back and the hand held inside until normal contraction takes place, but if it cannot be replaced, immediate laparotomy and traction from above, with direct transfusion, should be performed. When several days have elapsed and replacement after laparotomy fails, a hysterectomy may be necessary or reversion performed after opening the vesico-uterine peritoneal pouch, stretching the cervix from side to side, and making an incision through the cervix and uterus to within one-third of an inch of the fundus. The possibility of a weakening of the fundus by its being the placental site should be borne in mind in expressing the placenta from above.

661. "Eclampsia" Fits in a Case of Chronic Nephritis after Decapsulation of Kidneys.

ANDÉRODIAS and DARRIGADE (*Journ. de Méd. de Bordeaux*, March 10th, 1921) report the following case: A woman, after one normal labour and two miscarriages, had an acute attack of nephritis. She again became pregnant, and at the seventh month had an "eclampsia" fit, and labour was induced. Six months later Professor Pousson operated for the chronic nephritis and performed a bilateral decapsulation of the kidneys. Nine months afterwards the patient was admitted to hospital, when she was seven and a half months pregnant. In spite of the previous treatment she again had fits, and pregnancy was terminated. This case illustrates, according to the authors, the importance of chronic nephritis in the etiology and the severity of eclampsia. It further shows that in some cases decapsulation may not help in subsequent pregnancies.

PATHOLOGY.

662 Abortive Treatment of Experimental Syphilis.

VECCHIA (*Il Policlinico*, Sez. Prat., March 14th, 1921) carried out the following experiments on rabbits. Having produced two initial lesions in one animal (rabbit A), he inoculated with the material a first series of rabbits (B, C, D, E) in the scrotum. Rabbit D was kept as a control, and rabbits B, C, E were given intravenous injections of novarsenobenzol 0.01 eg. per kilogram on the second, fourth, and sixth days after infection respectively. While the control rabbit D developed two syphilomata at the inoculation site forty days after inoculation, the rabbits B and C remained completely immune from syphilitic manifestations, and when killed three months after inoculation rabbit C showed no naked-eye or microscopical lesions. On the other hand, the rabbit E, which had been treated on the sixth day after infection, developed an ulcer at the inoculation site on the twenty-fifth day, with corresponding adenitis of the inguinal glands, and on the fiftieth day a definite syphiloma in both testes appeared, from which the *Spirochaeta pallida* was obtained. Vecchia then carried out a second series of experiments with rabbits F, G, and H, which were treated on the first, third, and fifth days after infection with intravenous injection of 0.03 eg. novarsenobenzol per animal, or 0.01 eg. per kilogram, with negative results in each case. Finally, rabbit B of the first series and rabbits F, G, H were again inoculated with syphilitic material rich in spirochaetes and did not receive any treatment. On the twentieth day rabbits G and H and on the thirty-fourth day rabbits B and F

developed primary lesions containing spirochaetes. Vecchia suggests that the abortive method of treatment described is specially suitable in cases of professional inoculation of syphilis, such as may occur in doctors and nurses.

663. Action of Intravenous Injections of Glucose and Gum Arabic Solutions on Diuresis.

CORI (*Wien. klin. Woch.*, April 14th, 1921), as the result of experiments on dogs and observations on man, comes to the following conclusions: (1) Intravenous injection of hypertonic glucose solution has a marked diuretic action on the dog. An abundant discharge of chlorides into the blood takes place, accompanied by a correspondingly large amount of water. If, as the result of a diet poor in chlorides, a smaller amount of chlorides is discharged, the diuretic effect is also less. (2) The increased excretion of chlorides from the tissues into the blood is still present even after twenty-four hours. (3) Absorption and excretion of salts (nitrates) introduced into the stomach are abnormally accelerated as the result of the injection of glucose. (4) In man, solution of glucose does not have a diuretic action, as the chlorine is more firmly anchored in the tissues. (5) Intravenous injection of 7 per cent. gum arabic reduces the excretion of sugar in diabetes. The amount of urine is also much reduced. (6) The same solution of gum arabic causes a slighter excretion of iodine in the dog than in a control animal. (7) Gum arabic solution has only a weak diuretic effect in the dog, and does not produce a discharge of chlorides into the blood. Unlike glucose diuresis, therefore, there is only a water diuresis, and not a diuresis of chlorides as well.

664. The Pathogenesis of Myoclonus.

ACCORDING to PILOTTI (*Il Policlinico*, Sez. Med., April 1st, 1921), who records a fatal case in a woman aged 37, with the autopsy findings, the pathogenesis of myoclonus is still obscure in spite of all the hypotheses put forward to explain it, and in spite of all the anatomical lesions with which an effort has been made to associate it, whether lesions were found in the cortex, the spinal cord, or other regions of the central nervous system. As a general rule cases of myoclonus, whether they have a chronic course like Pilotti's patient and a few similar ones which have been studied histologically, or an acute course like the cases of epidemic encephalitis of the myoclonic type, present as a rule too great a complexity, both in their clinical and histological manifestations, to allow one to distinguish with certainty those lesions which are alone responsible for the motor disturbances from those which have nothing to do with them. Pilotti is of opinion that the origin of the myoclonic movements is not confined to a single area such as the cortex, spinal cord, or mid-brain, but that in addition to myoclonic movements which are undoubtedly of cortical origin, other lesions in the cord or mid-brain may cause these motor disturbances by a hitherto unexplained mechanism.

665. Spirochaetosis Icterohaemorrhagica.

DARGEIN and PLAZY (*Bull. et Mém. Soc. Méd. des Hôp. de Paris*, March 17th, 1921) record a case of spirochaetosis icterohaemorrhagica in a sailor at Toulon which was remarkable for the following points: (1) Absence of an epidemic focus: as the man had not left Toulon for some time and had been living in a place swarming with rats, the supposition of contamination elsewhere could be excluded. (2) None of his comrades was affected. (3) In spite of numerous careful examinations it was impossible to find the *Spirochaeta icterohaemorrhagiae* in the urine on direct examination, and the nature of the jaundice could only be determined by inoculation of a guinea-pig. The writers therefore insist on the importance of not excluding the diagnosis of spirochaetosis icterohaemorrhagica on the negative result of examination of the urine, and recommend that inoculation of a guinea-pig, or, failing that, the serum diagnosis or reaction of neutralization (Martin and Pettit), should always be performed.

666. Cancer of the Stomach with Remarkable Metastases.

VAN DER PERK (*Nederl. Tijdschr. v. Geneesk.*, January 1st, 1921) records a case in a woman, aged 47, in whom the most prominent symptoms during life were fracture of the right clavicle and sixth rib and blood in the stools. There were no gastric symptoms. The autopsy showed a carcinoma near the pylorus and metastases in both ovaries, the right clavicle, pleura, and paravertebral tissue from the third to the sixth rib. No lesions were found in the liver, spleen, pancreas, intestine, uterus, or omentum.

EPITOME OF CURRENT MEDICAL LITERATURE.

MEDICINE.

667. Atypical Epidemic Encephalitis.

HASSIN, STANGL, and BAILEY (*Journ. Nervous and Mental Diseases*, March, 1921) point out that many cases of lethargic encephalitis may be clinically atypical, although perfectly typical pathologically. Notes of two cases are given, in neither of which were any of the typical signs present, the clinical symptoms being delirium, rigid pupils, and an acute febrile course with negative serological findings. The lesion is always in the mid-brain, in the region of the Sylvian aqueduct and the peduncles, the manifestations being principally involvement of the third nerve. This did not show as ptosis or other ocular extrinsic paralysis, but as an intrinsic paralysis in the form of sluggish or rigid pupils. In all cases, therefore, of suspected epidemic encephalitis the pupils should be carefully examined, since it is impossible to imagine the occurrence of such a widespread lesion of the mid-brain without some ocular manifestations being present.

668. A Peculiar Mental Syndrome following Epidemic Encephalitis.

FRANCIONI (*Il Policlinico*, Sez. Prat., April 25th, 1921) describes a special syndrome which he has observed in about 20 children aged from 2 to 13 years, both sexes being equally represented. All the patients showed more or less pronounced psychological changes, there being either excessive irritability or violent behaviour, or, on the other hand, apathy and lassitude, changes in affectivity shown by indifference to their parents, and changes in their general appearance. The intellectual faculties, however, were not much affected, so that some of the children continued to attend school. Only a few of the patients showed more pronounced psychological symptoms, such as an exaggerated motor restlessness, motor and verbal stereotypy, tendency to lying, or fngues. The most important symptom, however, which was present in every case, was the occurrence of insomnia. It was first of all noted that the slight psychological changes mentioned became more pronounced towards evening. When the children were put to bed they were quite unable to go to sleep, but remained in a state of psychological and motor restlessness until the early morning. Francioni emphasizes the fact that the condition was not really a disturbance of sleep, because when once the children succeeded in getting to sleep the sleep was long, deep, and quiet. The other symptoms consisted in a moderate degree of loss of flesh, slight trophic changes in the skin and muscles, loss of appetite, vomiting, yawning, and sighing. The syndrome had a chronic course, and it was only after several months' observation that a slight improvement occurred. In some of the cases there was a history of a recent acute febrile disease with the characteristics of epidemic encephalitis, and Francioni thinks it probable that even where there was no such history the condition was due to the same cause, especially as most of his cases occurred at a time (January and February, 1920) when epidemic encephalitis was prevalent. He states that Fiore had seen four similar cases in children aged 3 to 12 years at the Florence Paediatric Clinic, and alludes to the recent paper by Roasenda (see EPITOME, April 9th, No. 433).

669. Lethargic Encephalitis of Long Duration.

TURRETINI and PIOTROWSKI (*Paris méd.*, April 30th, 1921) record a case of lethargic encephalitis in a woman, aged 24, in whom the disease lasted nine months. The symptoms consisted of obstinate drowsiness, followed by very marked hypertonus and trismus, which necessitated artificial feeding. The ocular symptoms were very slight. The writers have found only three similar cases on record—namely, two reported by Leonomo, in which the disease lasted two years and eight months respectively, and one by Ascoli. They remark that a very prolonged course is peculiar to the lethargic form, for it has never been observed in the myelonic variety or other forms of epidemic encephalitis.

670. The Prolonged Mental Forms of Epidemic Encephalitis.

ACCORDING to PETIT (*Bull. et Mém. Soc. Méd. des Hôp. de Paris*, April 28th, 1921) the mental forms of epidemic encephalitis may assume a subacute, acute, or hyperacute course. Some cases are characterized by an abnormally

long course, which is sometimes interrupted by remissions or intermissions. Petit records three cases in which there persisted for more than a year, either continuously or with remissions or intermissions, various psychopathic syndromes, such as acute delirium, mental confusion, hallucinations, impulsions, and phobias, which were shown by the transient appearance of certain organic signs to be due to epidemic encephalitis.

671. Pituitary Extract and Histamin in Diabetes Insipidus.

GIBSON and MARTIN (*Archiv. Int. Méd.*, March 15th, 1921) studied experimentally the effects of lumbar puncture, pituitary extract, and histamin administration, the nitrogenous metabolism, the blood constituents, and the carbohydrate tolerance in a severe case of diabetes insipidus with chronic syphilis. Lumbar puncture did not relieve the symptoms, the polyuria being rather increased on the day of the puncture, and on the following day. Pituitary extract given subcutaneously increased for a time the concentration, and reduced the volume of the urine; histamin gave a similar though less effective result. On the day following the first pituitary extract injections, and on subsequent intervening non-pituitary days, a decrease in the polyuria with a relative increase in concentration was maintained. Desiccated whole pituitary substance, in four 3-grain doses orally, produced a slight immediate effect. A lower nitrogen elimination resulted from the pituitary extract injections, with diminished ammonia and a somewhat increased uric acid output. Glycogenesis was not reduced, and there was hypoglycaemia.

672. Vaccine Treatment of Asthma.

MINET (*Bull. de la Soc. Méd. de Paris*, February 10th, 1921) records three cases of asthma treated with autogenous vaccines (mostly made up of staphylococci, streptococci, and *Micrococcus tetragenus*). In the first case no certain result followed, but in the other two excellent results were obtained, and the patients expressed themselves as delighted. In each of these two cases the asthma was of long duration (in one case from infancy, in the other for fifteen years), and neither was able to work. Since treatment they were able to work. At first the injections made the patients worse, but after about eight or nine injections improvement set in, and the final results were surprisingly good.

673. Purulent Meningitis in Uraemia.

BANG (*Norsk. Mag. for Laegvidenskabn*, March, 1921) discusses the genesis of "aseptic purulent meningitis" associated with uraemia. In one of his cases there were signs of chronic nephritis and uraemia; the blood pressure was raised (125-175 mm.) and the intraspinal pressure was much above normal. At the first lumbar puncture the cerebro-spinal fluid was perfectly clear. Next day it was very cloudy and contained numerous polymuclear leucocytes, but no microbes. The clinical picture was rather that of uraemia than meningitis. Thus, there was headache with vomiting, partial loss of consciousness, and urea retention, but the reflexes were unaffected, Kernig's sign was not demonstrable, and there was no cervical rigidity. In another case there were also signs of uraemia with coma; the cerebro-spinal fluid was purulent and blood-stained and no microbes could be found. The author admits that in neither of these cases was an attempt made to cultivate anaerobic microbes from the cerebro-spinal fluid, and he notes that the same omission has been made by other writers who have described similar cases. With such flaws in the bacteriological evidence, it may be that the purulent cerebro-spinal fluid in such cases has, after all, a septic, inflammatory origin. But at present it is not possible to dismiss as untenable the view that this condition of the cerebro-spinal fluid is due to an accumulation of urea in the system.

674. Treatment of Tetanus by Curare.

SCHÖNBAUER (*Wien. Klin. Woch.*, February 17th, 1921) records a case of severe tetanus successfully treated by curare after failure of tetanus antitoxin. Subcutaneous injections were given, starting with 2 mg. and increased daily until the dose of 5 mg. had been reached. An attempt to raise the dose to 6 mg. led to transient paralysis of the respiratory muscles causing considerable dyspnoea, so that

the dose of 5 mg. was continued, and it was found that the convulsions, which sometimes occurred every hour, completely subsided after administration of curare. The injections were at first given daily at 7.30 a.m., and kept the patient free from attacks until about 4 p.m., when more or less violent convulsions began again. It was therefore decided to divide the dose, and from the tenth day 3 mg. were given in the morning and 3 mg. in the evening daily. After another five days the attacks were only caused by an unusually violent external stimulus, such as washing in cold water. The patient received 63 mg. of curare in all in the course of fourteen days.

675. Intrathoracic Neoplasms.

FISHBERG and STEINBACH (*Med. Record*, March 26th, 1921), in discussing the diagnosis of intrathoracic neoplasms, consider that physical examination of the chest is more trustworthy than any other diagnostic method; they rely mainly upon the flat note elicited by percussion over the site of the tumour. Dyspnoea and pain in the chest are two early symptoms, as these rarely occur in early phthisis, and pulmonary neoplasm should be borne in mind when a patient at the cancer age begins to cough and is short-winded, while showing no signs of cardiac, renal, or arterial disease. The dyspnoea in cancer is due to the occlusion of a large bronchus either from within or from without, and when a primary bronchus is affected this may be very severe. Next to dyspnoea pain is a constant symptom, and its presence, with or without a pleural effusion, is suggestive. Fever may be present in some cases, making the differentiation from pulmonary tuberculosis difficult, but physical examination of the chest will generally settle the diagnosis. Enlargement of superficial glands in the neck between the heads of the sterno-mastoid, or in the axilla, is a late symptom, the tumour being by that time quite extensive and detectable. Enlargement of the superficial veins of the chest and shoulder is not common and occurs only in cases in which metastasis has occurred in the mediastinal glands. The flat note on percussion over the site of the tumour is more to be relied upon than radiography in diagnosis, the dull area, as a rule, being much more extensive than the size of the growth, so that even small tumours are more easily found by percussion and auscultation than by x ray. Feeble or complete absence of breath sounds, or bronchial breathing, occur when a bronchus is blocked entirely or only partially. Nearly all laboratory aids to diagnosis, while in some cases confirmatory, in most are of no value or altogether misleading, and even radiography may prove misleading or negative. The presence of fluid often obscures a tumour, so that the fluid should be withdrawn and a pneumothorax produced if radiography is to be of use in such cases.

SURGERY.

676. Enterostomy for Post-operative Ileus.

MÜLLER (*Hospitalstidende*, February 23rd and March 30th, 1921) emphasizes the difficulty of distinguishing between mechanical and dynamic intestinal obstruction within the first two weeks of an operation. In and after the third week intestinal obstruction is usually due to mechanical causes, whereas in the first fortnight this condition is often due to a combination of mechanical and dynamic causes. The author records eight cases of acute appendicitis in which he performed enterostomy for intestinal obstruction within eleven days of the original operation. In all these cases the intestinal obstruction had lasted for days, and mechanical and medicinal treatment had proved futile. Five of his patients recovered, and great relief was experienced by the other patients, who succumbed to general peritonitis in spite of this treatment. Discussing the dis-favour into which enterostomy for post-operative ileus fell some years ago, the author points out that much depends on the technique and not delaying the operation till the patient is moribund. With regard to the former point, he insists on the enterostomy opening being as small as possible. In some of his cases he punctured the gut with a Paquelin cautery, the opening being just large enough to admit a Pezzer catheter. He experienced no difficulties with the enterostomy wound, which invariably closed of itself within a few weeks. There were no subsequent mechanical complications, no formation of an artificial anus, and no disturbances from inanition. Though he admits that in theory the success of this operation may partly depend on the level at which the opening is made in the small intestine, he found in practice that it was best to puncture forthwith the most distended section of gut which presented itself on re-laparotomy.

88o B

677. Retropharyngeal Abscess.

FRIEDMAN and GREENFIELD (*New York Med. Journ.*, April 20th, 1921), from an experience of 60 cases of acute primary retropharyngeal abscess, point out that early and adequate internal incision will ensure rapid and complete recovery in most instances, and they strongly advise against drainage through an external incision, even when the external swelling is extreme. In the authors' experience the condition occurs mostly within the first three years of life, the youngest being 21 days, though older children and adults may suffer, as shown by the oldest case being 20 years old. In the large majority of cases the condition is associated with diseased tonsils and adenoids, or purulent rhinitis. The most pronounced symptoms are those of obstruction in the pharynx, a rind, in infants, those due to pressure on the larynx, with fever, restlessness, hoarseness, and dyspnoea. The condition may be mistaken for acute tonsillitis, but palpation of the pharynx with the finger will reveal a fluctuating swelling, and such examination should always be made in infants presenting any cervical glandular enlargement, or with a rigid neck. In operating no anaesthetic is needed, and is generally inadvisable in a child whose respiratory channel is already impeded. With the patient tightly wrapped in a sheet, and held in the upright position by an assistant who steadies the head, a vertical incision is made into the mass with a curved bistoury, care being taken to reach the lowermost limit of the abscess cavity. Immediately after incision the child is lowered face downwards, and the pus allowed to drain away. Relief and complete recovery quickly follow, and in no instance was it necessary for the authors to repeat the operation. After-treatment consists in local cleanliness, tonics, and nourishing food.

678. Association of Tonsillar Chancre and Vincent's Angina.

SOUCHEZ (*Rev. de lar., d'otol., et de rhinol.*, March 31st, 1921), after referring to the different appearances assumed by tonsillar chancre, especially the polypoid form described by Portmann (see EPITOME, April 24th, 1920, No. 444), emphasizes the difficulties of diagnosis when a tonsillar chancre is associated with Vincent's angina. He records a case in which the clinical and bacteriological appearances were those of Vincent's angina, and it was not until the appearance of an eruption on the face and serotum that the presence of syphilis was suspected. Another examination then showed the presence of the *Spirochaeta pallida*, as well as the fuso-spirillar symbiosis characteristic of Vincent's angina, and a positive Wassermann reaction. Souchez emphasizes the dangers of a hasty and incomplete bacteriological examination in cases of persistent ulceromembranous tonsillitis, and recommends that in doubtful cases one should not be content with examination of a superficial scraping of the diphtheroid deposit covering the ulcer, but should examine the serous discharge which may show the presence of the *Spirochaeta pallida*.

679. X-Ray Treatment of Interstitial Keratitis.

JAPIOT and BUSSY (*Journ. de Radiol. et d'Électrol.*, March, 1921) state that though x rays have never been systematically employed in the treatment of interstitial keratitis, there is no disease of the eye in which this method is more indicated, interstitial keratitis being a disease which is characterized, at least at the onset, by an infiltration into the layers of the cornea of young connective tissue cells, susceptible to the action of x rays, and without severe lesions in the cornea or marked changes in its structure. In order to be successful x-ray treatment must be employed during the period of infiltration before deep lesions of the cornea have given rise to indelible scars. The younger the patient and the greater the infiltration the more favourable the results, the greatest benefit being obtained in cases due to inherited syphilis. The method consists in irradiation of the closed eye with very small doses, without special protection or localization. In most cases five applications with a week's interval between each are sufficient, the duration of each application being five minutes. The irradiation probably acts not by destroying the cells but by mobilizing them, the action being similar to that which occurs in adenitis, splenomegaly, and sciatia. The method does not damage the lids or the ocular membranes, or arrest the development of the lens. It is quite painless, and does not require any fixation of the eye. It should be added to and not replace the usual treatment for interstitial keratitis, such as atropine, dionine, yellow ointment, mercury, and iodides. It produces a very rapid relief of pain, photophobia, and blepharospasm, shortens considerably the course of the disease, and if employed in time causes an absorption of the infiltration better than any other method.

680. Diverticula of the Urinary Bladder.

SECORD (*Canadian Med. Assoc. Journ.*, April, 1921) considers that congenital deformity or lack of development is an etiological factor in all cases of diverticula of the urinary bladder. Occurring chiefly in males over 50 years of age, the symptoms vary with the presence or absence of infection. A characteristic subjective symptom is a feeling that the bladder does not empty itself, causing a frequent desire to urinate. A suggestive symptom is difficulty in starting the stream, which flows freely when once started. Pain is variable, and is apparently due to the degree of distension of the diverticula. Pus is usually present, and it is suggestive of this condition if, during bladder washings, some are quite clear while others contain pus. Cystoscopic examination clears up the diagnosis, and the extent of the diverticulum may be ascertained by x-ray examination after passing an opaque ureteral catheter through the cystoscope when it can be seen coiled up in the diverticulum. Treatment consists in complete separation and removal of the sac at its neck through the suprapubic extraperitoneal route. When the entire sac is isolated it should be inverted into the bladder, the neck transfixed and ligated intravesically, and the remainder incised, the deficiency in the muscular wall of the bladder being closed by continuous suture. Multiple diverticula are dealt with in the same way.

681. The Characteristics of Appendicitis in Old Age.

PAUS (*Norsk Mag. for Laegevidenskaben*, April, 1921) notes that appendicitis is commonly regarded as a disease of comparatively early life, and that in older patients there is nearly always a history of attacks of abdominal pain since childhood. Most of the serious acute cases develop before the age of 50, but there is a small class in which the disease does not flare up till old age and in which there is no record of previous attacks. In one year alone he has seen five cases of acute appendicitis in patients over 50, and in several respects these cases differed much from the typical appendicitis of youth and middle life. In senile appendicitis there is a tendency for perforation to occur early—often within a few hours of the onset of the symptoms. The general symptoms are largely obscured by the local symptoms, which are comparatively prominent. Thus, there is little or no rise of temperature, the pulse remains practically normal, vomiting is rare, and the general condition is often but slightly upset. The power of reaction in the aged is comparatively small, and by the time a correct diagnosis has become feasible gangrene and perforation have often occurred. In all the author's cases the local symptoms were marked, the pain in some being like that of the most severe colic.

682. Masked Cystalgic Pyelitis.

PIRONDINI (*Archiv. Ital. di Chirurg.*, December 20th, 1920) draws attention to a form of pyelitis characterized by painful and frequent micturition both day and night, and often very uniform in its regularity. The pain lasts a long time. The patients are often neurasthenic, or become so from the long suffering. The urine is more or less turbid, but contains no tubercle bacilli, and haematuria is present only occasionally at the end of micturition. Pain in the renal region is not a marked feature, and as a rule the general condition is good. The pain, chiefly over the bladder or in the vagina, makes one think of cystitis, but there is no cystitis. Catheterization of the ureters shows there is pyelitis. There may be some tenderness over the classical renal or ureteric painful spots, but this is not a constant sign. The urine is turbid, often acid, contains a little albumin, and pus cells. There is no bacilluria. There is a certain amount of functional limitation and a diminution of the power of concentration in the urine (hyposthenuria). The cystoscope shows no sufficient cause for the symptoms in the bladder, and the ureteral orifices are, as a rule, normal. In treatment it is very important never to over-distend the bladder; instillation is therefore better than lavage.

683. Iodine Powder as a Substitute for Tincture of Iodine.

SCHERINGA (*Nederl. Tijdschr. v. Geneesk.*, March 19th, 1921) remarks that, though tincture of iodine is a rapid and effective antiseptic, it possesses certain drawbacks. In the first place it requires to be freshly made, as if kept any length of time various irritating compounds are formed. Another disadvantage of tincture of iodine is that it rapidly acts on cork, so that the bottle containing it does not close tightly and the alcohol soon evaporates. On the other hand, a dry powder composed of iodine and talc 2½ to 5 per cent., has none of these drawbacks, and is much cheaper, pleasanter to use, and easier to apply.

OBSTETRICS AND GYNAECOLOGY.

684. Perineal Hysterectomy.

CUSLE and PICOT (*Journ. de Chirurg.*, March, 1921) describe the technique of an operation for total hysterectomy by the perineal route in cases of cancer of the cervix. Their operation differs from paravaginal hysterectomy by use of Schuchardt's incision and approach combined with Schauta's closure of the vagina after dissection of a cylindrical cuff; it resembles Zuckerkandl's hysterectomy after perineotomy in that the cutaneous incision has its convexity directed forwards and is made in a transverse direction from one to the other tuber ischii. The steps of the operation are: (1) Opening of both ischio-rectal fossae and separation of the rectum from the vagina as far as the pouch of Douglas; (2) median incision of the posterior vaginal wall and transection of the vagina at the upper limit of this incision; (3) dissection of the vaginal wall above the transection, an iodine tampon being placed over the cervix; (4) separation of the cervix from the bladder and opening of the vesico-uterine cul-de-sac; (5) ligation of the vaginal and uterine arteries; (6) division of the round ligaments, followed by removal of the uterus, adnexa, and vaginal cuff; (7) reunion of the peritoneum and suture of the lower portion of the vaginal wall together with the perineal incision. According to Cuslé and Picot, this operation is particularly useful in the case of obese subjects, abdominal operation on whom in the high pelvic position presents difficulties both to the surgeon and to the anaesthetist. The lithotomy position is adopted and the authors prefer spinal anaesthesia.

685. Caesarean Section for Obstruction by Ovarian Cyst.

RIVIÈRE (*Journ. de Méd. de Bordeaux*, March 10th, 1921) reports a case of a primipara, aged 23, on whom a Caesarean section was performed. He examined the patient when she was seven months pregnant, and found that the head would not engage. On vaginal examination the cervix was felt pushed forward, and there was a hard tumour in the posterior fornix. At first this was mistaken for a foetal hand, but on a further examination two weeks later it was diagnosed as an ovarian cyst. A successful Caesarean section was thereupon performed.

686. Cancer of the Cervix of Borderline Operability.

WEISS (*Amer. Journ. of Obstet. and Gyn.*, April, 1921) records his conclusions regarding the treatment of borderline cases of carcinoma of the cervix, defined as "cancer with a moderate amount of tissue friability and fixation of adjacent structures, which fixation may be malignant or inflammatory in character," and including also early cases of adenocarcinoma, of which the prognosis is much worse than of the squamous-celled cauliflower type of growth. A few days' rest in bed is always advisable as a preliminary to operation; in addition to an improvement in the general condition, it happens not infrequently that a diminution becomes manifest in the thickening and fixation of the broad ligaments, proving that these signs were due to inflammatory rather than to malignant invasion of the lymphatics, so that a supposedly inoperable case becomes operable or "borderline." When a doubtful borderline condition is present, treatment by radium is advisable (1) as the sole therapeutic measure when operation is contraindicated by reason of age, general condition, or renal or cardio-vascular affection; (2) in other cases as the initial measure, the performance of subsequent operation being determined by the reaction obtained. Such treatment appears to give somewhat better results than the improved Byrne cautery technique. In fifteen borderline cases the author has had good results, free from fistula formation, by high cautery amputation of the cervix, followed by application of radium (1,200 to 2,000 mg.-hours); high amputation by the cautery is preferable to the so-called Percy cauterization. For the prevention of onward complications following radium therapy, Schmitz's precaution of keeping the bladder and rectum empty during the application is important. The author speaks with reserve of radium treatment as a preliminary to radical operation: a dosage of 2,400 mg.-hours of radium element does not as a rule, it is said, produce heavy scar tissue.

687. High Forceps Operation in Contracted Pelvis.

MEUMANN (*Zentralbl. f. Gynäk.*, April 30th, 1921) reports, among 2,432 cases of contracted pelvis, 100 labours in which delivery was essayed or accomplished by high forceps operation. This procedure is adopted (symphysiotomy or Caesarean section being contraindicated)

when (1) the foetus is alive and urgent maternal conditions make speedy delivery imperative; (2) the mother's condition is satisfactory but the foetal life is in danger, which may be averted by forceps delivery. If several forcible tractions prove unsuccessful perforation is performed, the foetus usually being moribund. Extraction was successful in 84 cases, and the child was born alive in 60. Analysis of the figures appears to show a smaller foetal mortality by application of forceps to the head after its engagement. As regards foetal survival, the prognosis in the generally contracted cases is seen to be worse than in the flat pelvis. The series was free from maternal mortality.

688. The Cuti-reaction during Menstruation and after Ovariectomy.

COULAND (*Bull. et Mém. Soc. Méd. des Hôp. de Paris*, February 17th, 1921) performed the cuti-reaction in 80 cases during and apart from the menstrual period, and in 5 found that it was negative at the onset of menstruation, and also negative in 2 cases when menstruation was expected to appear but was delayed. In 12 cases there was a distinct difference in the reactions performed during and apart from menstruation, the menstrual cuti-reaction being much less pronounced. In no case was a cuti-reaction which was negative between the monthly periods positive during menstruation. Couland also performed the cuti-reaction in 53 patients who had undergone ovariectomy on one or both sides, and on 53 controls who had had various other operations, the results being as follows: After unilateral ovariectomy the number of negative cuti-reactions was 44 per cent., and after bilateral ovariectomy 50 per cent., whereas after various other operations it was only 19 per cent. The onset of menstruation and ovariectomy therefore appear to the author to be accompanied by a phase of tuberculin anergy similar to that observed during labour by Nobécourt and Paraf.

689. Pelvic Lavage in Treatment of Pyelitis of Pregnancy.

In a preliminary report by BANGMAN (*Amer. Journ. of Obstet. and Gynec.*, February, 1921), the author gives details of six cases of pregnancy pyelitis treated by washing out the pelvis of the kidney. All the cases were improved to some extent, but it was still considered advisable to induce labour as soon as the child was viable. The article is illustrated by interesting reproductions of bromide pyelograms.

690. Semi-symphysiotomy.

COSTA (*Zentralbl. f. Gynäk.*, February 12th, 1921), describes a very original operation for cases of flat pelvis obstructing labour. Put briefly, the operation consists in shaving a piece off the posterior surface of the symphysis pubis. The author maintains that: (1) It is practically a bloodless operation; (2) that it is an easy operation, without any risks; (3) that it increases the true conjugate by $2\frac{1}{2}$ to 3 cm. He gives details of four cases in which he has successfully performed this operation.

PATHOLOGY.

691. The Blood in Osteomyelitis.

PEWNY (*Wien. Klin. Woch.*, March 10th, 1921) examined the blood in eighteen cases of osteomyelitis before and after operation, with the following results. Before the operation the total number of leucocytes was often considerably increased (up to 17,000), normal values being very rarely found. The neutrophil leucocytes were also increased up to 89 per cent. or 14,000. The number of lymphocytes was much diminished in a large number of cases, and increased in a small number of cases, but in the latter the presence of tuberculosis was probable. The condition of the eosinophils varied considerably, a diminution being often observed. Another examination made two or three weeks after sequestrectomy showed a considerable diminution of the leucocyte count, the number of the neutrophils being normal, and often below the normal. The number of lymphocytes had usually returned to the normal, and there was an increase in the eosinophils, indicating that the infection was cured. The number of the red cells and the haemoglobin still showed a reduction in the third week after the operation. The leucocyte count did not always correspond to the size of the sequestrum or to the degree of suppuration.

692. Transmissibility of Human Herpetic Keratitis to the Rabbit's Cornea.

LUGER and LAUDA (*Wien. Klin. Woch.*, March 24th, 1921) state that Gruter's discovery that herpetic keratitis in man can be transmitted to the rabbit's cornea has recently been confirmed by a number of writers, such as Dörr and Voechting, Kraupa, Löwenstein, Stoker, Sulmann, and the present writers. Although hitherto characteristic changes had not been described in the rabbit's cornea inoculated with human herpetic keratitis, Luger and Lauda were able to demonstrate in the epithelial cells of the inoculated cornea certain changes in the nuclei resembling those found by themselves and independently by Lipschütz in febrile herpes, a result which was to be expected owing to the clinical relationship of corneal and febrile herpes to one another. The changes in the nuclei consisted in a displacement of the chromatin to the periphery of the nucleus and a thickening and crumpling of the nuclear membrane, while the inner part of the nucleus was filled with a homogeneous mass which showed a distinct predilection for acid dyes.

693. Epithelioma following X-Ray Treatment for Tuberculosis of the Knee.

KJAERGAARD (*Hospit. Ustidende*, March 30th and April 6th, 1921) reviews the literature of x-ray malignant disease, and contributes the case of a woman, aged 22, who from the age of 12 and for the next five years was given x-ray treatment at irregular intervals for tuberculosis of the knee. Following an injury to this knee, chronic ulceration supervened, and ultimately a typical epithelioma developed. The patient refused amputation till it was too late, and the necropsy showed extensive tuberculosis of the lungs and intestines, as well as amyloid disease. There was no secondary malignant disease, not even in the regional lymphatic glands. Discussing x-ray malignant disease, the author classifies it according as it develops in persons working with the x rays, or in patients treated by them. By 1911, 54 cases belonging to the second category had been recorded, and these did not include cases occurring in the subjects of lupus, for this disease is apt to be followed by malignant disease even in the absence of x-ray treatment. Since 1911 only a few cases of x-ray malignant disease have been reported as a sequel to therapeutic exposures, but the author thinks this present immunity may be more apparent than real, and that the relation of cause to effect may often be obscured by the length of the interval (several years) between x-ray treatment and a manifestation of malignant disease.

694. Application of Cutaneous Sensitization to Diseases of the Skin.

ENGMAN and WANDER (*Arch. of Derm. and Syph.*, March, 1921), following on the work of Chandler Walker in relation to asthma, tested the sensibility of the skin to various proteins, such as wheat, milk, egg, beef, pork, potato, bean, also proteins of *Staphylococcus albus*, *aureus*, and *citricus*. The tests were made through an incision 1.8 in. long on the inner side of the forearm by a very sharp scarifier, producing as little trauma as possible. The part was then moistened with saline, and the protein about to be tested added. Half an hour was always allowed for the reaction, but often a positive reaction developed in a few minutes. The diseases studied in this way were acne, urticaria, erythema multiforme, pemphigus, trade dermatitis, dermatitis vegetans, and the eczema group. From the excellent results obtained cutaneous sensitization tests are, the authors state, especially valuable in urticaria and eczema. To be of most value it is essential to study a case with those proteins with which the patient comes in contact in his daily life. From a therapeutic standpoint the difficulty is the control of the diet, but where control can be exercised excellent results follow. Desensitization of a case is sometimes possible.

695. B. tetani in the Digestive Tract of Herbivora.

ACCORDING to NINNI (*Ann. d'igiene*, December, 1920), *B. tetani* can always be found in various segments of the gastro-enteric canal of small laboratory herbivora, such as rabbits and guinea-pigs, by means of broth cultures. The bacillus is almost always toxic, but its toxicity varies. To determine the toxicity the only certain method is to use a pure culture by heating the faeces to 60° C. for an hour to eliminate the non-sporing organisms, especially those which interfere with the production of toxin, such as *B. bulgaricus*, *B. acidi lactici*, and *B. mucosus capsulatus*.

EPITOME OF CURRENT MEDICAL LITERATURE.

MEDICINE.

696. The Infectiousness of Whooping-cough.

AT the Serum Institute in Copenhagen, MEYER (*Vgeskrift for Læger*, April 21st, 1921) has examined the cultures sent by practitioners to the Institute and obtained by holding aluminium bowls, containing Bordet's culture medium, in front of coughing patients. Between February, 1916, and September, 1920, 1,665 such bowls were returned, and it was found that while Bordet-Gengon bacilli were demonstrable in 75 per cent. of all the cases examined in the early catarrhal stage, they were demonstrable only in 9 per cent. of the patients who had whooped for five weeks or longer. In March, 1916, the school medical service decreed that children might return to school when the whooping had lasted four weeks, but the author points out that this isolation period should be prolonged to five weeks from the date of the first whoop. After this period patients may be regarded as practically non-infectious, for after the fifth week of whooping only a few patients continue to be carriers. The author urges practitioners to send blood as well as "cough cultures" for examination, for the complement fixation test often gives useful information with regard to coughs about the etiology of which practitioners are uncertain. In whooping-cough, complement fixation is demonstrable after the third week, the test remaining positive for months and sometimes even years.

697. Pnëumococci and Streptococci in Influenza.

LOGAN (*Linn. Med. Journ.*, May, 1921), from a study of the pneumococci and streptococci groups in their relation to influenza, concludes that the disease may be divided into three stages: a primary stage, when the unknown infecting virus apparently acts alone, though frequently accompanied by other organisms which may become active later; a secondary stage, when pneumococci and streptococci actively produce pulmonary complications; and a tertiary stage, when saprophytic mouth organisms may invade the already diseased lung. Although pulmonary complications might never arise in the absence of pathogenic pneumococci or streptococci, it does not follow that infection by these organisms is necessarily followed by pulmonary complications. The type of complication was found to be largely dependent on the type of pathogenic organism present, pneumonias with extensive consolidation being associated with pneumococci of Types I, II, and III, bronchopneumonia and bronchitic complications being due to others of the group and hæmolytic streptococci. The part played by other organisms was not investigated, but the presence of complex infections in epidemics does not mean that the original bacterial cause was not a single type.

698. Mongolism.

THURSFIELD (*Brit. Journ. Child. Ins.*, January-March, 1921) records his observations on 43 Mongolian imbeciles seen at the Hospital for Sick Children, Great Ormond Street, between the beginning of 1912 and 1916. After discussing possible etiological factors, such as the place of the Mongolian imbecile in the family, the age of the mother, her health during pregnancy, history of miscarriages, character of the labour, infective diseases, and prevention of conception, the author gives figures showing the frequency of cardiac and other defects among his cases. Of 25 patients whom he was able to trace 14 were dead, the causes of death being chiefly bronchopneumonia and diarrhoea. The oldest survivor was aged 15 years and the youngest 6 years. None of them showed the least tendency to become normal with increasing years, though the more obvious signs of mental defects were certainly lessened. Like certain French physicians who have been able to keep Mongols under observation for a long period in institutions, Thursfield is convinced that both physical and mental improvement can be derived from small doses of thyroid, though there is no prospect of obtaining the effects commensurate with those observed in the case of cretins.

699. Neuro-encephalitis Simulating Paralysis Agitans.

LEIVSON (*Vgeskrift for Læger*, February 24th, 1921) has observed two cases in which influenza was followed by symptoms simulating paralysis agitans. The first case was that of a man, aged 44, who in August, 1918, was confined to bed for a short time by an attack of influenza. In

the course of a month this attack was followed by restlessness, paraesthesia, and slight pain in the arms and legs. He felt extraordinarily tired and experienced great difficulty in walking, standing, and writing. Examined in February, 1920, he exhibited paresis of both arms and legs, where the sensations of pain, touch, and temperature were reduced. The tendon reflexes were very weak, and there was considerable tenderness over the nerve trunks and muscles of the arms and legs. So far the clinical picture was that of polyn neuritis. But the patient's expression, gait, and carriage were indicative of paralysis agitans. A little later the author saw another case in which the simulation of paralysis agitans was still more remarkable. The patient was a woman, aged 33, who was confined to bed for about a month early in 1920 by a severe attack of influenza. Her gait was disordered, partly by pain in the legs, partly by tremor and rigidity. Her movements were slow and laboured and her face wore the mask-like expression of paralysis agitans. The tremor of the legs was greatest on the right side. In addition to anaesthesia of both arms and legs there was a peroneus paralysis on the left side with reduction of the electrical irritability in the peroneus area.

700. Treatment of Leishmaniasis.

POTT and JAVARONE (*La Pediatra*, February 15th, 1921) record the results of treatment of 73 cases of leishmaniasis at the Naples Paediatric Clinic since 1915: 63 were treated by intravenous injections of antimony tartrate, 8 by intramuscular injections of sodium acetyl-p amino-phenyl antimonate, and 2 by the same drug intravenously. In children up to 3 years they began by injecting 2 c.c.m. of a 1 per cent. solution of antimony tartrate, and the dose was gradually increased to 3, 4, and 5 c.c.m. In older children the first dose was 2 to 3 c.c.m. and the subsequent doses 5, 6, and 7 c.c.m. There was an interval of at least two days between each injection to allow of the elimination of all the antimony introduced. The doses of sodium acetyl-p amino-phenyl antimonate were generally 3 cg., afterwards increased to 10 cg., for children under 2 years, and in older children the initial dose was 5 cg. and the subsequent doses 10 to 15 cg. The injections were given on alternate days. Of the 73 cases, 56 recovered and 17 died. The results were better the earlier the treatment was applied and the better the general condition of the patient at the time of the onset of the treatment. The highest mortality occurred in early infancy and progressively diminished later. The cause of death was not the leishmaniasis, but intercurrent disease, especially respiratory and digestive disorders.

701. Treatment of Dysentery.

KLEERSMAKERS (*Arch. ned. Belg.*, January, 1921) states that during the summer of 1920 a certain number of men belonging to the Brussels garrison were attacked with acute bacillary dysentery of the Flexner type. Of 170 men admitted to hospital with dysenteriform stools 75 showed Flexner's bacilli. Almost all the cases were of a mild type, but a few had an attack of moderate severity. There were no grave, prolonged, or anomalous forms. For the first two days the patients were kept on a water diet, consisting of 2 to 2½ litres of water containing 2.5 grams of sodium chloride and 2.5 grams of sodium bicarbonate per litre. On the third day they were given a vegetable broth, and in mild cases boiled starchy food. On the fifth and sixth days bread, butter, the yolk of an egg, and mashed potatoes were added. If by then the stools were normal, half the ordinary hospital diet might be allowed, except that meat was not given too soon. Milk was entirely forbidden. Local treatment consisted in a large evacuant enema, followed by an enema containing 4 grams of benzol, 5 drops of 40 per cent. formal, 1 gram of tragacanth, 5 grams of glycerin, to 150 grams of water. As regards vaccine treatment, in most of the cases Rathery's method was used. A polyvalent Flexner vaccine containing 50 million bacilli per cubic centimetre was used. The following doses were given: first day ½ c.c.m., second day ½ c.c.m., third day 1 c.c.m., fifth day 1½ c.c.m. Almost all the patients became convalescent after three or four injections. Reactions were very rare and slight. In some cases, especially in carriers, a polyvalent or auto-vaccine was used in progressive doses at intervals of four days—namely, on the first day 10 millions, fifth day 20 millions, ninth day 40 or 50 millions, and so on.

702. Barium Sulphate in the Treatment of Gastric and Duodenal Ulcer.

GALAMBOS (*Wien. Klin. Woch.*, February 10th, 1921) recommends the substitution of barium sulphate for bismuth subnitrate in the treatment of gastric and duodenal ulcer, as it possesses the following advantages, namely, complete insolubility, harmlessness, cheapness, and tastelessness. The action of barium sulphate generally resembles that of bismuth salts in its forming a protective layer over the gastric or duodenal ulcer, as is proved by x-ray examination. The constipating action of barium sulphate, on the other hand, is less marked than that of the bismuth salt, and it therefore leaves the gastro-intestinal canal more rapidly than bismuth. Another advantage of barium sulphate is that while bismuth subnitrate, owing to its conversion into the sulphide, gives a greenish-black colour to the stools, and thus interferes with the naked eye recognition of occult haemorrhage, the white barium sulphate makes the presence of haemorrhage in the stools more distinct. Although Galambos has hitherto employed barium sulphate only for gastric and duodenal ulcer, he recommends it for other diseases in which bismuth is commonly used, such as dysentery, paratyphoid fever, cholera, enteritis, and proctitis due to various causes.

703. The Residual Nitrogen in Infectious Diseases.

WAGNER (*Wien. Arch. f. inn. Med.*, August, 1920), from a study of cases of typhus, relapsing fever, enteric fever, malaria, dysentery, pneumonia, tuberculosis, septicaemia, encephalitis lethargica, and various other febrile conditions, comes to the following conclusions: (1) Every acute febrile disease may give rise to azotaemia. In chronic febrile processes this condition is usually absent. (2) The rise in the residual nitrogen in the blood does not depend upon the height of the temperature, and is apparently independent of the condition of the kidneys, but probably depends on the degree of intoxication. Considerable differences are to be found in the intensity of the effect of the various pathogenic organisms or their toxins on the increase of urea in the blood. The deficiency of water in the body is not sufficient to explain the azotaemia in diseases associated with considerable loss of water. (3) In the majority of cases the excretion of urea through the kidneys rises parallel with the increase of urea in the blood, even when nephritis is present. (4) A large amount of urea in the blood (over 100 mg. urea to 100 c.c.m. of blood) must not be regarded as a bad prognosis, especially when it is only transient. (5) On the other hand, a persistent azotaemia which shows no tendency to diminish, or even increases, should always be regarded as an unfavourable sign.

704. Saccharin Intoxication.

GRUNDFEST (*Zentralbl. f. inn. Med.*, March 26th, 1921) remarks that, in spite of the almost universal employment of saccharin during the last few years, he has seen only one case of typical saccharin intoxication, although occasionally some of his patients have always complained of headache and loss of appetite after taking it. The typical case was that of a man, aged 45, who, three days after taking saccharin for the first time to sweeten his coffee, presented a bloated face, swollen eyelids, and chemosis, together with a feeling of irritation in the larynx. The temperature was normal, the faucial and laryngeal mucous membranes showed nothing special, and the voice was not hoarse. There was no albumin in the urine. On discontinuing the saccharin the symptoms rapidly disappeared, but some days later, when the patient had taken only three spoonfuls of coffee sweetened with saccharin, the feeling of irritation in the throat returned. The case was therefore an example of extreme idiosyncrasy for saccharin.

705. Pernicious Anaemia and Malaria.

CODA (*Il Policlinico, Sez. Med.*, March 1st, 1921) records two cases in malarial subjects, aged 42 and 56 respectively, who presented all the symptoms of pernicious anaemia. The blood picture in the first case showed haemoglobin 20 per cent., red cells 650,000, colour index 1.5, leucocytes 3,000, pronounced poikilocytosis, anisocytosis, megalocytes, polychromasia, and megaloblasts. There were also anorexia, diarrhoea, and achylia gastrica. In the second case, in which achylia gastrica was also present, the red cells numbered 1,200,000, the leucocytes 4,000, haemoglobin 35 per cent., colour index 1.4. There were also anisocytosis, anisochromia, a few normoblasts, megaloblasts, and myelocytes. Recovery took place in both cases under quinine treatment.

SURGERY.**703. Radical Cure of Haemorrhoids.**

DRECK (*Amer. Journ. of Surg.*, April, 1921) insists upon as thorough preparation of the patient for an operation for haemorrhoids as for a laparotomy, and his technique is described for operating under local anaesthesia with 0.5 per cent. solution of apothesine or procaine. Minute details are given for infiltrating the whole field of operation and blocking the sphincter and coccygeal nerves. Slow but thorough dilatation of the sphincter is essential and requires careful manipulation to prevent tearing the mucous membrane at the anal margin, since trauma increases the risk of perirectal abscess formation. When the haemorrhoid has been brought well outside it is distended with a solution of 0.5 per cent. quinine and urea hydrochloride, which is injected also into the pedicle and into the normal mucous membrane for half an inch above the pile. This is then bluntly dissected out through two incisions in the mucous membrane commencing above the tumour and carried down on each side. The pedicle, after being thoroughly freed, is firmly tied, one end of the ligature being passed through the stump and tied across the encircling ligature to prevent slipping. The patient is kept on his side or face for the first day to lessen the tendency to swelling, and is restricted to liquid diet. Soup, broth, egg albumen, buttermilk, and cream, but not milk, are given two-hourly, followed by semi-solids on the second day. At the end of this time 6 oz. of liquid paraffin are injected through a soft catheter, and each day after an 8 oz. enema of physiological salt solution is given. Among advantages claimed for this method are: non-injury of the sphincter muscles, freedom from secondary haemorrhage, a smooth level resulting scar, and impossibility of recurrence.

707. Spontaneous Rupture of the Bladder.

HANSEN (*Hospitalstidende*, April 6th, 1921) notes that spontaneous rupture of the bladder precipitated by such acts as defaecation, micturition, lifting weights, and blowing a trumpet, is far less common than traumatic rupture. To the question Can retention of urine alone provoke rupture of a normal bladder? he can give no definite answer, for the cases bearing on this point have, for the most part, occurred under the influence of alcohol. And it is notorious that under alcohol rupture of the bladder may be traumatic without the patient being able to remember the trauma. In this connexion the author records the case of a man, aged 55, whose rupture of the bladder did, indeed, occur during a drinking bout, but as during this bout he was quietly locked up in his own flat, it is unlikely that he had received a blow over the bladder. Nor was there any evident sign of such a blow. The case terminated fatally, and the necropsy showed slight adenomatous enlargement of the prostate. There was no other cause found to account for the retention of urine and there was no marked evidence of cystitis. The bladder had given way in the sagittal plane; a 10 cm. long, clean-cut tear ran down from the top of the bladder through its posterior wall and communicated with the peritoneal cavity. Careful microscopic examination of the walls of the bladder near this tear revealed no abnormal fatty infiltration or hyaline degeneration of the muscles; there was only some infiltration with blood. This case would, therefore, suggest that a practically normal bladder may rupture spontaneously if over-distended.

703. Pneumoperitoneum and Radiological Diagnosis.

STEIN and STEWART (*Arch. med. Belg.*, February, 1921) have employed the method of pneumoperitoneum or insufflation of gas into the abdominal cavity in 150 cases without ill effects, as a preliminary to radiographing the abdominal organs, which are thus separated from one another and present distinct outlines. The method is, they hold, of great value in the diagnosis of various lesions, especially of large organs such as the liver, spleen, and kidneys, and it is the only process which reveals adhesions between the abdominal wall and the organs contained in the abdomen or shows the contents of a hernia. The choice of the gas to be employed depends upon circumstances. If the examination is of short duration, like screening the liver or gall-bladder, carbon dioxide should be used, because it is absorbed in about twenty minutes. A mixture of equal parts of carbon dioxide and oxygen is absorbed in thirty-five to forty minutes. Oxygen disappears slowly, and is suitable for prolonged examinations, such as complete examination of the abdominal cavity. The contraindications to pneumoperitoneum mentioned are acute

peritonitis and the presence of serious circulatory or respiratory disturbance. The technique is simple, the materials required being a lumbar-puncture needle, two rubber tubes each one metre in length, a rubber bag containing four litres like that used in gas anaesthesia, and a receptacle containing the gas. One of the rubber tubes connects the receptacle with the bag, and the other the bag with the needle. The patient, who has been purged and had his bladder emptied, is laid on the table to be screened, having received an injection of morphine a quarter of an hour before the operation. The skin of the abdomen is rendered aseptic with iodine, the needle is introduced two to three fingerbreadths below the umbilicus into the peritoneal cavity, and gas is then allowed to pass slowly in by turning a cock. The amount of gas used depends upon the state of tension of the abdominal wall, and varies from two to four litres. When sufficient gas has been introduced to make the wall as tight as a drum the needle is rapidly withdrawn and the puncture wound closed.

709. Intraperitoneal Infusion in Adults.

LOEWENHARDT (*Zentralbl. f. inn. Med.*, March 3rd, 1921) recommends for use in adults the method of saline infusion introduced by Weinberg in infants, the technique of which he describes as follows: The patient's pelvis is slightly raised, and the skin of the hypogastrum disinfected with iodine on the right or left side according to choice. The junction of the centre and middle thirds of the imaginary line connecting the umbilicus and anterior superior spine is chosen as the site of injection. The needle is introduced by a slight turning movement, so that every layer which is traversed is felt. When the peritoneum is pierced some fluid is run in under pressure so as to drive any part of the bowel out of harm's way. One and a half to two litres of fluid may then be injected in the usual way, the fluid being either normal saline or Ringer's fluid to which dextrose or drugs may be added. Intraperitoneal infusions are indicated generally in all cases where a larger quantity of fluid has to be injected. They are always to be preferred to subcutaneous injections, as apart from the slight prick of the needle they are entirely painless, and the time required for the infusion is three to four times less than that of subcutaneous injection, while the power of absorption of the peritoneum is considerably greater than that of the subcutaneous tissue. Loewenhardt prefers intraperitoneal infusion to intravenous injection in all cases in which there is any technical difficulty about the latter. He has never observed any sign of peritoneal irritation following his method.

710. The Action of Spinal Anaesthesia on the Hepatic and Renal Functions.

RANUCCI (*Il Policlinico*, Sez. Prat., March 7th, 1921), owing to the disagreement among various writers as to the action of spinal anaesthesia on the kidneys and liver, made investigations on 67 cases which had undergone spinal anaesthesia for various operations with a mixture of stovaine 4 cg. and novocain 2 cg. The urine before operation was normal in all but 2 cases, in which there was slight albuminuria with granular casts. The examination was commenced with the first urine passed after the operation and continued for about a week. The ages of the patients ranged from 16 to 75. The post-operation course was normal in each case. With a few exceptions, in which a catheter was required for a few days, micturition was spontaneous in each case. Diminution of the total quantity of urine was constant. In the two cases in which albuminuria was present before the operation there was only a slight increase in the amount of albumin in the urine. In 20 cases in which variations in the nitrogen of the blood and urine were investigated before and after the operation, Ranucci found that after the operation the nitrogen was always slightly increased in the blood, and considerably in the urine. He never found glucose, acetone, bile pigment, urobilin, or acetic acid in the urine. In 21 cases, or 34 per cent., albuminuria was present, but never more than 1 in 1,000. In 6 cases albuminuria was present in the first specimen of urine passed after the operation—that is, six to twelve hours after the intraspinal injection. In 5 cases hyaline and granular casts were present. In no case did the duration of the albuminuria exceed seven days. Ranucci considers that the albuminuria is due, not to the action of the stovaine on the renal epithelium, but to its action on the nerve centres. His observations show how slight and transient are the lesions caused by spinal anaesthesia in the organism, especially in the liver and kidneys. The method can therefore be adopted in patients with renal and hepatic diseases with much less danger than is associated with general anaesthesia.

711. Trauma and Parenchymatous Keratitis.

ROSICA (*Il Policlinico*, Sez. Prat., February 28th, 1921) has observed more than a hundred cases of parenchymatous keratitis in the ophthalmological clinic at Rome and in military hospitals at Rome, Florence, and elsewhere, 80 per cent. being undoubtedly due to inherited syphilis, with a positive Wassermann reaction. In only two cases could the keratitis be attributed to trauma, which in one case was an occasional cause in a subject of inherited syphilis, while in the other, who presented the clinical picture of Fuchs's disciform keratitis, there was a small area of loss of epithelium in the centre of the cornea. The course of both these cases was completely different from the typical form of diffuse parenchymatous keratitis. Rosica comes to the following conclusions: (1) In typical parenchymatous keratitis a trauma does not constitute the determining cause. Although it is possible in very rare cases that it may be an occasional cause, Rosica has never seen or read of a case, with the possible exception of one reported by Armaignac, in which keratitis which occurred in one eye after an injury was followed by similar lesions in the other eye after an interval of seven weeks. (2) In atypical forms of parenchymatous keratitis, on the other hand, trauma may constitute the determining cause, as in various forms of disciform keratitis and in cases of circumscribed and unilateral interstitial keratitis.

712. Torsion of the Gall Bladder.

HANSEN (*Hospitaltidende*, March 30th, 1921) finds that torsion of the gall bladder is so rare that barely half a score of cases have been recorded. The condition has never been diagnosed before operation, and has usually been confused with acute cholecystitis or appendicitis. Only in one case have gall stones been found in connexion with the torsion, and though the symptoms were most alarming and most of the patients were women of about 70, an operation has usually been followed by complete recovery. The author supplements this general survey with an account of a woman, aged 79, who suddenly developed violent abdominal pain with repeated vomiting of brownish-green, foetid fluid. She was admitted to hospital twenty-four hours later with the diagnosis of intestinal obstruction. Examination led to the opinion that she was suffering from impaction of a gall stone in the cystic duct. Laparotomy revealed an hour-glass gall bladder, the neck of which was twisted 360 degrees in the direction of the hands of the clock. The gall bladder was easily untwisted and its lower portion resected. Neither the gall bladder nor bile ducts contained stones. The patient was perfectly well on her discharge. Considering the thickness of the neck of the hour-glass, it is curious in the first place that the torsion should have occurred, and in the second place that it should not have corrected itself.

OBSTETRICS AND GYNAECOLOGY.

713. Pathology and Treatment of Leucorrhoea.

ACCORDING to REDER (*Amer. Journ. of Obstet. and Gynec.*, April, 1921), leucorrhoea not dependent on any morbid state may precede or succeed a normal menstrual function in a healthy woman, irrespective of age; the leucorrhoea of children consists almost entirely of a discharge from the glands of the vulva and is commonly associated with constipation, ascariasis, or uncleanness. Two chief varieties of pathological leucorrhoea may be recognized, the former being the more common and more obstinate: (1) mucous or cervical leucorrhoea, in which the discharge consists chiefly of mucous corpuscles and plasma, secreted chiefly in the follicular canal of the cervix; (2) leucorrhoea of the epithelial variety, where the discharge is secreted by the vaginal portion of the os and cervix and is freely mixed with scaly epithelium and its debris. The assumption of a mucopurulent character is due to bacterial contamination; gonorrhoeal infection is specially prone to persist in the os and cervical canal after the vaginal walls and the urethra have become healthy. The great majority of cases require both constitutional and local treatment. Ordinary douching is useless in the treatment of pathological leucorrhoea. The author states that after thorough cleansing of the vagina and cervix with liquid soap and warm water, followed by an alkaline ablation, the cervical canal should receive like treatment, a naturally small or a stenotic os being previously dilated. Cervical erosions and ulcerations may be treated by applications of solid silver nitrate, pure carbolic acid, or a 10 per cent. mixture of thymol iodide in cod-liver oil. Hypertrophy, hyperplasia, and granular ectropion of the cervix demand

tracheloplasty, trachelorrhaphy, or even amputation. Atony and relaxation, bordering on prolapse, of the vaginal walls may be relieved by the insertion of a hard rubber ring pessary. A vaginal tampon should be made of soft gauze, such as is produced by boiling a gauze bandage until starch-free and drying. Foss's method of packing the cervical canal, fornices, and upper vagina with gauze soaked in methylene-glycerin solution has given satisfactory results; the tampon is renewed daily for five days and followed by two dry packs. Alternatively, dry tampons, alternating with tampons soaked in a 5 per cent. solution of picric acid in 25 per cent. alcohol and left *in situ* for eight hours, may be used.

714. Air Embolus after Criminal Abortion.

ACCORDING to HORNUNG (*Zentralbl. f. Gynäk.*, April 16th, 1921) the occurrence of air embolus after attempts to induce criminal abortion is not very rare; fatal cases coming to autopsy have been described by Richter and others. The writer relates the case of a girl, aged 20, three months pregnant, who suddenly, after an eighth injection of soap and water, given through an india-rubber syringe with a rigid nozzle 12 cm. long, experienced air hunger and severe pain and lost consciousness: at the same time she became cyanosed, and brisk vaginal haemorrhage was noticed. Examination five hours later showed a penetrating wound producing a cervico-vesical fistula; the lips were still cyanotic, there were petechiae on both arms, and a small recent retinal haemorrhage was noted. The convalescence was apyrexial, and the patient was discharged on the eighteenth day with the fistula healed; abortion occurred two weeks later. The occurrence of petechial haemorrhages in the systemic circulation is susceptible of two explanations: (1) that the patient, in common with 25 per cent. of all individuals (according to Lubarsch) possessed a patent foramen ovale; (2) that bubbles of air had passed through the lung capillaries. That this can occur in experimental conditions was shown by Bicbat, who injected hydrogen into the trachea and recovered an inflammable gas from a peripheral artery.

715. Caesarean Section in Acute Oedema of the Lungs.

STRAULI (*Schweiz. med. Woch.*, March 17th, 1921) discusses at some length the publications dealing with severe heart disease in relation to pregnancy. He contributes a case observed by himself in which, towards the end of pregnancy, severe endocarditis and mitral disease led to acute oedema of the lungs, with expectoration of much frothy bright red fluid. The patient was a primipara, aged 25, whose symptoms were so alarming that there seemed little prospect of recovery. She was very dyspnoeic, her face and lips were livid, and rales were audible all over the lungs. Within four hours of the onset of acute pulmonary oedema Caesarean section was performed in twenty-five minutes under light ether anaesthesia. At the end of the operation the patient looked better, and her lips were less cyanosed: in the evening of the same day the dyspnoea had passed off, her lips were red, and her general condition was satisfactory. She passed large quantities of urine during the next few days, oedema of the legs and lower abdomen subsiding simultaneously. To prevent recurrence of pregnancy both Fallopian tubes were resected under local anaesthesia about three weeks after the Caesarean section. When she reported herself some months later both she and her child were perfectly well, and she no longer suffered from swelling of the feet, palpitation of the heart, digestive disturbances, or other symptoms. The author regards this case as a cogent argument in favour of terminating pregnancy artificially as soon as pulmonary oedema and other manifestations of a disordered circulation become alarming.

PATHOLOGY.

716. Haemoglobinuria after a Second Blood Transfusion with Same Donor.

THALHIMER (*Journ. Amer. Med. Assoc.*, May 14th, 1921) reports the case of a boy who was transfused with his father's blood, a direct test of these bloods, made both by macroscopic and by microscopic methods, having previously detected no agglutinins. The transfusion was performed by the citrate method, and was followed by a mild febrile reaction only. Eighteen days later a similar transfusion was performed with the same donor, and after about 150 c.cm. had been given a most severe and unexpected reaction occurred. The transfusion was, of course, immediately stopped, and a few hours later the patient voided

very dark, haemoglobinuric urine; this showed that haemolysis had occurred, and explained the reaction. The cause of the intravascular haemolysis was also subsequently discovered. Two tests were overlooked in preparing for these transfusions. Had these been performed, another donor would have been selected, and the agglutinative and haemolytic phenomena would not have taken place. Yet on superficial examination it would seem that all the necessary precautions had been taken. A direct test of the bloods gave absolutely no agglutinins or haemolysis. This was further demonstrated by absence of agglutination or haemolysis after the first transfusion. The success of this led to the omission of the tests before the second transfusion. It is known that in many instances repeated transfusions have been made with the same donor and recipient with no bad results. This case, together with some experimental transfusions in animals, demonstrates the necessity of performing tests before each transfusion, even though the same donor, who was previously satisfactory, is used. The two errors were: (1) in performing only direct tests on the two bloods and not also determining the blood groups; (2) in not repeating the direct tests before the second transfusion. Several weeks later the blood groups (Jausky nomenclature) showed the patient to belong to Group I and the donor (the patient's father) to Group III.

717. The Haemoclastic Crisis as Evidence of Hepatic Impairment.

FOSSATI and MAMONE (*Revista Sud Americana*, March 15th, 1921) record 21 cases in which they have applied the tests of the function of the hepatic cells described by Widal, Abrami, and Lancovesco (*Comptes Rendus des Séances de l'Académie des Sciences*, July 12th, 1920). According to these authors, when there is impairment of hepatic cellular function the albumoses and peptones resulting from intestinal digestion and absorbed via the portal venous system are only in part metabolized in the liver; a portion not there intercepted reaches the systemic circulation, provoking a "peptone reaction," characterized especially by leucopenia, with relative diminution of lymphocytes, diminution of arterial pressure, and alteration of the coagulation time of the blood. This "haemoclastic reaction," occurring within three hours after administration (following a fast) of 200 grams of milk, is taken as evidence of impaired efficiency of the hepatic cell. Fossati and Mamone regard this as a test of great simplicity and precision, having considerable diagnostic value; its use may be of prognostic importance when surgical intervention is contemplated for affections of the liver or bile passages. The authors' tests showed that in normal individuals, or in a number of cases where the hepatic cells were unaffected (for example, cases of typhoid fever, gastric ulcer, cholecystitis), there ensued the ordinary digestive leucocytosis with relative lymphocytosis. On the other hand, in cases, for example, of early catarrhal jaundice, portal cirrhosis, or hepatic carcinoma, the haemoclastic reaction was well marked. A partial reaction, consisting in some leucopenia with relative lymphocytosis, was observed in a case of hypertrophic biliary cirrhosis and in one of chronic subicteroid malaria. The haemoclastic reaction was absent in three cases of cholelithiasis. Unlike Widal, Abrami, and Lancovesco, the authors found the haemoclastic reaction absent as a rule in cases of chronic passive congestion of the liver consequent on heart disease. In estimating the reaction less importance is said to attach to blood pressure and blood coagulation measurements than to the blood count.

718. Experimental Transplantation of Fascia.

CHIRONI (*Il Policlinico, Sez. Chir.*, March 15th, 1921), as the results of experiments on dogs, came to the following conclusions: (1) Transplantation of free flaps of fascia which are thin and of small size undergo degeneration, with gradual substitution of newly formed connective tissue as the result of a proliferation of the connective tissue elements derived from the surrounding tissues and from the transplanted portion itself. (2) On the other hand, a portion of the fascia lata transplanted from the same animal retains its complete vitality and normal histological structure with the exception of small necrotic zones, probably due to transient circulatory disturbances. (3) The elastic fibres of the fascial tissue keep in a good state of preservation, and often increase in number without invading the surrounding tissues. (4) When the portion of fascia lata is required to functionate, it modifies the direction of its fibres according to the traction exerted on it.

EPITOME OF CURRENT MEDICAL LITERATURE.

MEDICINE.

719.

Reduction of Nervous Irritability.

JACOBSON (*Journ. Nerv. and Ment. Dis.*, April, 1921) urges the importance of the principle of progressive relaxation in the reduction of nervous irritability and excitement, or nervousness. Since overactivity or increased tonus of the central nervous system, as shown in tenseness or excessive movement of striated muscles, is under voluntary control it is sought to cultivate such control in order to counteract excessive activity, thereby quietening the nervous system. Experience shows that when the patient learns how to relax the voluntary system a similar quiescence follows in the autonomic apparatus, the emotions tending to subside as he relaxes. The method consists of voluntary continued reduction of contraction or tonus of muscle groups, the relaxation being progressive in each group and consecutively with other groups, so that the patient tends towards a state in which quiet is automatically maintained. When an unpractised person lies as quietly as possible on a couch there still remains some residual tension, or voluntary fine contraction, which has further to be overcome for successful results. The practised person aims at noting the location of tenseness and doing away with it, yet attention must not be concentrated on his muscles, as all effort, even the effort to relax, has to be avoided. In simplest form the patient is directed to relax whatever parts appear to be tense, or a few representative muscle groups may be selected for practice on the assumption that progressive relaxation of one part tends to be followed by a similar condition in other parts. Treatments vary in duration and number according to the case, averaging about thirty minutes, repeated weekly or bi-weekly.

720. The Rate of Propagation of the Arterial Pulse Wave.

LAUBRY, MOUGEOT, and GIROUX (*Arch. et. méd. de com.*, February and March, 1921), as the result of their investigations on the rate of propagation of the arterial pulse wave in health and disease, come to the following conclusions: (1) The rate of propagation of the arterial pulse wave in physiological conditions is about 8 metres a second in the upper limb and 9 metres in the lower limb. (2) In all cases in which the rate was determined in the lower limb below Scarpa's triangle, it was distinctly less than in the upper limb. (3) Under pathological conditions the rate of propagation of the arterial wave varies in relation with the blood pressure, and the changes in the rate are related to the variations in the systolic pressure. (4) When the relation between the rate of the arterial pulse wave and the systolic tension is destroyed, signs of cardiac failure are almost always present. In other words, slowing of the pulse should, *et ceteris paribus*, be regarded as a sign of insufficiency of the left ventricle. (5) Loss of arterial elasticity produces such definite changes in the rate that a radio-femoral asynchronism results, the femoral being in advance of the radial pulse—an important sign in the diagnosis of thoracic or abdominal aortitis. (6) Sudden and localized changes in the calibre of the artery, as in pure aortic stenosis or aneurysm, has a distinctly retarding influence upon the rate. (7) The relations of the rate of the arterial pulse wave with the vascular tone were studied in disordered action of the heart, especially in Graves's disease, with inconstant results, the rate being normal in some cases and accelerated in others. (8) Determination of the rate of propagation of the arterial pulse wave is capable of giving valuable information, especially as regards vascular sclerosis, localized sclerosis of the aorta, and insufficiency of the left ventricle.

721. Digitalis in the Treatment of Hypertension.

ACCORDING TO DAMADE (*Gaz. hebdom. des Sci. Méd. de Bordeaux*, April 10th, 1921) until recently most clinicians were opposed to the use of digitalis in arterio-sclerosis or cardio-renal disease, at least before the stage of complete cardiac failure. The work of Vaquez and Lian, however, in 1913, on insufficiency of the left ventricle, of Martinet in 1914 on the laws of the circulation and diuresis, and of Josué and Godlewski in 1912 and of Gallavardin in 1920 on the use of digitalis, showed that this drug was also indicated in hypertension associated with failing compensation. Damade, who records four

personal cases, recommends that large doses should never be used, 10 drops of digitaline, repeated for four or five days, and in some cases half this dose, being sufficient. The treatment should be controlled by a daily study of the blood pressure. Any rise of the minimal blood pressure should be an indication to discontinue the treatment or to diminish the doses. The success of the treatment is an important factor in the prognosis. Damade having always found that failure to respond to digitalis is a bad sign.

722.

Zinc Chloride Poisoning.

MCCORD and KIRKER (*Journ. Amer. Med. Assoc.*, February 12th, 1921) report an outbreak of dermatoses from zinc chloride poisoning among workers in a wood-preserving industry. In addition to the dermatitis and acne due to tar, multiple lesions of the fingers, hands, and forearms were noted following upon some slight injury such as abrasions, splinters, burns, or chapping. The typical lesion was a small opening in the skin corresponding in size to the antecedent injury, but on examination the surrounding skin was readily removable, revealing white and bloodless underlying tissues, in the centre of which was a cylinder of escharotic tissue. When this was removed and the crater filled with sodium bicarbonate healing took place. The lesions occurred among workers with railway ties which had been subjected to treatment with zinc chloride solution, which after exposure to air approached saturation. Prevention for the hands was secured by the use of flexible "lined" canvas gauntlets, which were found to be impervious to the fluid and were comfortable, durable, and inexpensive, and by prompt treatment of all trivial injuries of the hands and forearms.

723.

Acute Nitrobenzol Poisoning.

LOFF, BOEK, and FITZ (*Amer. Journ. Med. Sciences*, April, 1921) find that the oxygen capacity of the blood in cases of nitrobenzol poisoning is markedly diminished, in one case as low as 6.2 volumes per cent., while the total amount of haemoglobin is unchanged, and that the symptoms are due to the fact that the blood loses its function of transporting oxygen. Nitrobenzol, besides being used in the manufacture of high explosives, is also used to a limited extent in perfumery, soap, confectionery, and cooking processes, in making dyes, in pharmaceutical laboratories, and in shoe dyes, and it is noticeable that the people who handle it in their daily work are not those who usually suffer seriously from its poisonous action, which in most instances follows drinking it, either by accident or intentionally. Symptoms are slow in onset and vague until unconsciousness occurs. The gastro-intestinal and nervous symptoms are mainly nausea, headache, and dizziness, with a characteristic steel grey-blue colour of the skin and mucous membranes. One remarkable feature is the rapidity with which a return to normal occurs in those who recover, one patient waking up and becoming apparently normal while transfusion was being performed. This is explained by the fact that the changed haemoglobin rapidly returns to normal, so that the body cells become reoxygenated quickly. There is no specific or antidotal treatment, but the stomach contents should be evacuated as quickly as possible, and bleeding and transfusion are indicated in severe cases.

724.

Tetrachlorethane Poisoning.

PARMENTEP (*Journ. Indust. Hygiene*, April, 1921) discusses the symptomatology and prevention of tetrachlorethane poisoning. Used largely during the war in connexion with aeroplane "dope," it is of commercial importance now in the manufacture of non-inflammable films, lacquered goods, and artificial silk. A typical case generally commences with symptoms of abnormal fatigue, discontent, general nervousness, and loss of appetite, accompanied, as the poisoning progresses, by nausea, vomiting, abdominal pains, and dizziness. Jaundice, with pale stools and bile-stained urine, may develop after several days or even weeks, followed in fatal cases by confusion, stupor, delirium, coma, and death, the insidious onset, lengthy duration of acute stage, and intense jaundice being the chief clinical features. Characteristic blood conditions may precede the clinical symptoms—an important factor in prevention, as well as in diagnosis and prognosis. The blood abnormalities include a progressive increase of large

mononuclear cells, the appearance of many immature large mononuclears, a slight elevation in the white count, a progressive slight anaemia, and a slight increase in the number of platelets, a percentage of large mononuclear white cells above 12 being the first sign of a reaction to tetrachlorethane. Blood examinations in connexion with clinical observations are necessary in regulating the employment of workers, and should render possible the prevention of all but very slight cases of poisoning. By suspending cases early from work for a time, by eliminating the susceptible, and by proper methods for enclosing and ventilating the processes and protecting the workers, tetrachlorethane may be rendered an entirely feasible material with which to work commercially, and no more difficult or hazardous to use than benzol, trinitrotoluol, or lead.

725. The Therapeutical Action of Ouabain.

ZUCCOLA (*Il Policlinico*, Sez. Prat., March 28th, 1921) describes ouabain as a glucoside extracted from a plant growing in the mountains in Somaliland. The opinions of botanists are divided as to which genus it belongs to. Ouabain is indicated in certain cases of cardiac insufficiency with acute dilatation of the ventricles and tendency to bigeminal rhythm which are not affected except unfavourably by digitalis. The drug should be administered intravenously, four injections being given every four hours, the first consisting of $\frac{1}{4}$ mg. and the others of $\frac{1}{2}$ mg. Zuccola has used ouabain in twelve cases of acute cardiac insufficiency secondary to mitral or aortic lesions, cardio-sclerosis, and infectious diseases. He found that after the first injection there was a rise of blood pressure, especially of the minimal blood pressure, whereas the maximal blood pressure did not show a corresponding rise. In correspondence with the rise of blood pressure there was a fall in the pulse rate, diuresis became more abundant, and there was improvement in the general condition. While not sharing the enthusiasm of some writers who maintain that it is absolutely harmless and has no cumulative action, Zuccola considers that in some respects ouabain may be regarded as superior to strophanthus.

726. Myocardial Tuberculosis

JAFFÉ (*Zeit. f. Tuberkulose*, April, 1921) states that in human pathology tuberculosis of the heart muscle plays only a small part, though it is by no means so rare as has been hitherto supposed. In general miliary tuberculosis miliary tubercles are frequently found in the walls of the heart (Thorel). Larger caseating tuberculous nodules have often been described in the myocardium. They may be solitary or multiple, and occur with predilection on the right side of the heart, especially in the right auricle. Among 1,200 tuberculosis autopsies which Jaffé performed during the war, he found myocardial tuberculosis twice. The distinction between syphilis and tuberculosis of the myocardium is often difficult to make, as the specific organism is frequently absent in the lesions. Tuberculosis of the myocardium in the human subject is usually haematogenous, infection being conveyed by the coronary vessels. Direct transmission of neighbouring tuberculous processes—for example, in the pericardium—and lymph-borne infection may also occur. Clinical signs of myocardial tuberculosis are most likely to develop when large areas of the myocardium, especially of the conducting system, are involved. In experimental myocardial tuberculosis in the guinea-pig, produced by intraperitoneal injection of one-thousandth of a milligram of tuberculin, Jaffé found that myocardial tuberculosis was a manifestation of a severe general tuberculosis, in which there was a rapid multiplication of tubercle bacilli in the organism.

727. Pneumococcal Septicaemia.

LAFFORGUE (*Bull. et Mém. Soc. Méd. des Hôp. de Paris*, March 3rd, 1921) agrees with Menetrier in the belief that pneumococcal septicaemia is more frequent than is generally supposed, as it can only be revealed by blood cultures. He adds, however, that the following three rules must be observed in making the examination for such cases: (1) A systematic blood culture should be made as early as possible in all cases of pyrexia whose nature remains undetermined, especially when they are accompanied by various eruptions. (2) Considerable quantities of blood should be used, 20 c.cm. being an indispensable minimum. (3) If, as is the rule in such cases, the blood culture is made on an ordinary medium, the blood should be diluted with a large quantity of the medium, a dilution of 1 in 10 being a good rule. By observing these rules Lafforgue was able to detect three cases of pneumococcal septicaemia, the first case being primary in the strict sense of the word, and the other two being associated with pulmonary tuberculosis and malaria respectively.

SURGERY.

728. Incomplete Fractures of the Scapula.

MOREAU (*Journ. de radiol. et d'électrol.*, March, 1921), who records four illustrative cases, states that the interest of fractures of the scapula consists in their rarity, only 18 examples having been found by Lonsdale among 1,900 fractures of all kinds. According to various statistics their average frequency is about 1 per cent. In spite of the view held before the discovery of *x* rays, fractures of the body are less frequent than those of the neck of the bone. The scapula readily escapes injury owing to its mobility on the thoracic wall, its protection by muscles, and the elasticity of its flattened portion. Fractures of the scapula have been divided by Tauton into fractures of the supraspinous and infraspinous fossae, fractures of the inferior angle, fractures of the supero-internal angle, and fractures of the spine. Incomplete fractures of the upper border of the scapula have a fairly definite individuality. They cannot be mistaken for fractures of the supero-internal angle, in which the detached fragment, which is always of considerable size, causes a well-marked deformity. There is no abnormal mobility or crepitation, as the fragment is too deep to be felt beneath the fibres of the trapezius and infraspinatus, but on palpation a distinctly tender spot is detected above the middle part of the spine of the scapula. Functional disturbances are ill marked. The lesion to the bone may escape recognition even on *x*-ray examination, for the cervical border of the bone is often difficult to see on the plate, especially on superficial examination. If left to itself incomplete fracture of the upper border of the scapula may be consolidated without leaving any loss of power, but often pain persists and there is a more or less marked limitation of the movements of the shoulder, and palpation of the trapezius above the spine of the scapula is painful. If this condition persists removal of the bony fragment is indicated.

729. Direct Fractures of the Calcaneum.

MOREAU (*Paris méd.*, April 16th, 1921) states that up till now little has been known about direct fractures of the calcaneum. Although they are undoubtedly rare in peace time, they were frequent during the war, and Quénu was able to collect 30 cases in 1916. Moreau has also observed 30 cases, in 17 of which the calcaneum alone was fractured, and in 13 there was an associated fracture of neighbouring bones, such as the cuboid, astragalus, scaphoid, and metatarsals. The diagnosis of a lesion of the calcaneum does not offer any difficulty when the projectile has struck the back of the foot in the submalleolar zone corresponding anatomically to the position of the calcaneum, although it cannot be definitely stated that the astragalus and cuboid are not also injured. But there are tangential lesions which may have grazed the bone without causing definite signs of fracture. In all these cases *x* rays will establish the diagnosis and determine the gravity of the prognosis. The prognosis is good when the bone is only grazed, even when there is secondary formation of an osteoma, and also in "tunnelization" of the bone by a bullet when the articulations with the astragalus and cuboid are not affected. In comminuted fractures the prognosis depends on the degree and extent of the bony lesions. In almost all Moreau's cases the foot could be preserved, and in only one case was it necessary to perform a supramalleolar amputation, and in another astragalotomy. In most of the cases scraping, sequestrotomy, and partial resections were sufficient.

730. Hallux Valgus, Rigidus, and Malleus.

JANSEN (*Journ. Orthopaedic Surg.*, March, 1921) points out that hallux valgus, rigidus, and malleus may occur separately, but are generally associated in varying degrees. Disturbance of muscle balance, most prominent in hallux valgus, and joint wear, most prominent in hallux rigidus, are the main principles underlying the deformities. Hallux rigidus is due to extra strain upon the first metatarsophalangeal joint, and may occur in people with everted foot and muscle weakness from ontgrowth of strength. Flattening of the metatarsal head, shortening of the bone, lipping and thinness of the joint cartilage are noticeable; the lipping causes pain in walking, gradually leading to permanent involuntary contracture of the flexor brevis muscle and producing hallux malleus. This latter, by causing the abductor hallucis to slide downwards, thus losing its abduction power, may produce hallux malleo-valgus when the power of the adductors prevail. Hallux valgus is generally produced by the wearing of narrow-pointed shoes with high heels causing luxation of the extensor proprius and flexor longus hallucis. These conditions may

be prevented by the use of well-fitting shoes with the inner border raised, attention being paid to muscle balance and joint wear. Transplantation of the abductor hallucis is useful, and with this may be combined shortening of the first metatarsal bone by Ludloff's method or by the removal of part of the metatarsal neck. In the discussion which followed upon Professor Jansen's paper complete removal of the head of the bone was considered to be the best line of treatment for the condition.

731. Non-union following Fracture.

ROBERTSON (*Canadian Med. Assoc. Journ.*, May, 1921) discusses non-union following fracture. Since fibrous union never becomes bony, interference is necessary in weight-bearing bones, either by a graft or a mortise. A bone transplant has no inherent value as a nidus from which bone will develop, but is merely a scaffold through which bone will grow and absorb what it replaces. In bone-grafting it is essential to have a wide expanse of raw viable bone intimately opposed to a wide expanse of transplant, so that revascularization and regeneration of the graft may rapidly occur. In mortising, union follows early when living fragment is opposed to living fragment. Technique varies with the bone to be treated. In the femur and humerus, with little loss of bone tissue, mortising produces a stronger union, and no attempt should be made to fill a defect by applying a transplant. Mortising is performed by making one fragment a spear-head and the other a cleft so shaped that when fitted together raw bone is intimately associated with raw bone held immobile with plate and screws of bone. In the radius, ulna, or tibia long defects may be bridged by transplants, since in each case there is a companion bone to assist in weight-bearing. With an accurately cut, firmly fitting, diamond-shaped graft, union is certain to occur. The limb is splinted in plaster-of-Paris for three months or longer. In military cases infection frequently occurs but does not preclude union; such infection usually gives rise to symptoms within thirty hours, though occasionally its development may not occur till later.

732. Pyelography and Ureterography.

GOLDSTEIN (*Amer. Journ. of Surgery*, April, 1921) considers ureterography and pyelography as absolutely essential for diagnosis in many urological conditions and as a great aid in differential diagnosis, being a harmless procedure not contraindicated in any abdominal cases presenting a suspicion of urinary tract lesion. No purgative should be given for twenty-four hours prior to the examination, so that the distribution of gas in the bowel may be undisturbed and so cause no difficulty in interpreting suspicious shadows. Plain radiograms are made first for comparison with the ureterogram or pyelogram. The next day cystoscopy and pyelography or ureterography are performed with a radiographic catheter, a Garceau catheter being used if leakage is present. The catheter is inserted slowly into the ureter on the suspected side for about eight or ten inches, the required distance being measured previously on the catheter, the aim being to allow its tip just to enter the kidney pelvis without lodging against any kidney tissue. If in doubt about measurements it is inserted until the natural obstruction is encountered and then withdrawn about an inch. With a graduated syringe sterile water is very slowly injected through the catheter until a sense of fullness or commencing pain is complained of in the renal region, this giving the capacity of the kidney. The opaque solution is next injected, 2 c.cm. less than the total amount of water being used, so as to avoid distension, and before removal of the catheter this solution is drained off and the kidney pelvis washed out with water. Both kidneys are never injected at one sitting.

733. Tourniquet for Intravenous Injections.

BARNES (*Med. Record*, April 23rd, 1921) describes an ideal tourniquet for use in intravenous injections which can be quickly and accurately adjusted and loosened. It consists of a half-inch wide woven strap with a buckle that catches at any point. After passing this round the arm and through the ends of a block of wood, over the upper surface of which it passes, it is fastened just below the block, which has been placed on the upper surface of the arm at the insertion of the deltoid. A wedge-shaped piece of wood is pushed between the top of the block and the strap until the desired degree of constriction is obtained. The block is sufficiently long to project beyond the convex surface of the arm, so that the skin will not be pinched against its ends when the strap is tightened, and the tourniquet is loosened by removing the wedge, which

can be easily done if necessary by the patient, thereby increasing the ease with which an injection can be given when there is no assistant.

734 Morning Pain in Renal and Ureteral Calculus.

BARSONY (*Wien. Klin. Woch.*, April 14th, 1921) maintains that the occurrence of pain in the morning in the renal region, sometimes radiating to the bladder and testes, should always suggest renal or ureteral stone. In some patients the pain occurs exclusively during the morning, and in others at other times as well. It seems as though small stones in the renal pelvis and those that pass into the ureter more frequently cause pain in the morning than larger stones. The cause of the pain occurring early in the morning is obscure. Barsony attributes considerable importance to the recognition of this pain, as it will prevent renal calculus being mistaken for intestinal obstruction or appendicitis.

OBSTETRICS AND GYNAECOLOGY.

735. Etiology of Tubal Gestation.

GRIESER (*Zentralbl. f. Gynäk.*, April 9th, 1921) has found that of recent years an increasing percentage of Fallopian tubes which have been the seat of ectopic gestation show, when submitted to microscopical examination, an absence of inflammatory appearances in the mucosa. Sobotta and others have shown that ciliated epithelium is absent from the Fallopian tubes of many mammals, and it has been suggested that in such animals the transit of the ovum is due, not to ciliary action, but to muscular peristalsis which is under nervous control. Grieser believes that in the human Fallopian tube both ciliary and peristaltic factors play a part, and notes that in the specimens (removed at recent operations for ruptured ectopic pregnancies) which showed no evidence of chronic inflammatory change, there was distinct hypoplasia of the tubal (and sometimes the uterine) musculature. This hypoplasia he attributes to chronic under-nourishment of the patients he during the war.

736. Torsion of the Virgin Fallopian Tube.

HEIL (*Zentralbl. f. Gynäk.*, April 9th, 1921) records a case of torsion of the Fallopian tube in a virgin. An unmarried woman, aged 27, two days after a slight abdominal trauma, suddenly fainted and began to have vaginal bleeding. Ruptured ectopic pregnancy was suspected. Examination under general anaesthesia showed the uterus to be of normal size; to the right was a movable tumour the size of the fist, while in the posterior and left fornices was a resistant and extremely tender swelling of similar dimensions but not quite so well defined. Exploratory puncture of the first-named tumour gave a thick fluid resembling the contents of a dermoid cyst; aspiration from the postero-lateral swelling gave thin fluid blood. The patient denied that pregnancy was possible. At laparotomy, performed three days later, the tumour on the right, which was shelled out and extirpated, was found to be an ovarian dermoid cyst, showing a commencing torsion; on the left the tube and ovary were found to be the seat of torsion of two and a half turns, and to be enlarged and congested. The tumour which had been palpable in the posterior and left fornices was an effusion of blood which had originated from the rupture of a follicular haematoma in the left ovary. Torsion of the Fallopian tube in a virgin is an event of extreme rarity; according to some authors, twisting of the tube occurs only in connexion with coexisting ovarian tumours, or with sacosalpinx.

737. Indications for Symphysiotomy.

SCHWARTZ (*Zentralbl. f. Gynäk.*, April 16th, 1921) describes his last 28 cases of symphysiotomy, which he has performed on 113 occasions in all, with results which lead him to draw favourable conclusions as to the value of the operation. Of the 28 cases, 15 were primiparæ and 13 multiparæ. In the former group birth after symphysiotomy was spontaneous in 4 instances; 1 vesico-vaginal fistula, 4 small (uncomplicated) haematomata of the labium majus, 2 cases of slight prolapse (after episiotomy), and 4 instances of slight haematuria were the post-operative complications encountered. Among the 13 multiparæ operative delivery was induced in all instances, and 2 patients suffered from small haematomata; 2 had previously undergone Caesarean section and 3 symphysiotomy. There was no foetal mortality. During the four days following operation the patients lie between sand-bags; they are allowed to stand on the eighth or ninth

day. Reviewing the criticisms which have been directed against symphysiotomy, the author points out that severe bladder injuries occurred in 5 only of his 113 cases and slight transitory haematuria in 22; it is to be remembered that extraperitoneal Caesarean operations are by no means free from similar complications. Of the 113 cases, extensive prolapse occurred in 6; against this must be set the low mortality and the fact that Caesarean operations carry with them the danger of hernia formation or of subsequent rupture of the uterus. Schwartz proceeds to a comparison of the drawbacks attaching to symphysiotomy and Caesarean section respectively. The maternal mortality of the latter operation has ranged in various hands from 2 to 6.3 per cent. (symphysiotomy 2.6 per cent.). The average foetal mortality reported after Caesarean section is lower than Schwartz's figure of 7 per cent. after symphysiotomy. Against this must be set, it is urged, the fact that symphysiotomy diminishes, while Caesarean section increases, the chance of foetal death in subsequent pregnancies. The author is accustomed to employ this method not only in head, but, when there is a moderate grade of pelvic contraction, in transverse and breech presentations. It is a special advantage of symphysiotomy under local anaesthesia that it may be performed in young primiparae; if after the operation it is evident that spontaneous birth is not to be expected, recourse may still be had to Caesarean section, or occasionally (in carefully selected cases) to delivery by forceps. Existing infection, a contra-indication for Caesarean section, is said not to diminish the applicability of symphysiotomy. The author summarizes the indications for the operation as follows: (1) In contracted pelvis with a true conjugate of 7.5 cm. and upwards, when, in spite of good uterine contractions and the use of Walcher's position, the head does not engage. (2) Moderate degrees of pelvic contraction associated with antecedent stillbirth; here metrorrhysis may be useful at the same time. (3) Moderate degrees of pelvic contraction, when there is transverse or breech presentation, or when podalic version is to be performed. (4) Brow or face presentations in pelvis of normal dimensions, when forceps are to be applied.

738. Treatment of Septic Abortion.

PECK (*Amer. Journ. of Obstet. and Gynec.*, April, 1921), who ranges himself with the advocates of conservative treatment for cases of abortion complicated by sepsis, employs Fowler's position and orders vaginal douching in exceptional cases only. Haemorrhage is regarded as the only symptom which may demand prompt and thorough emptying of the uterus. For the treatment of haemorrhage, vaginal packing of iodoform gauze (2 per cent.) is employed when dilatation of the cervix has not taken place, and cervico-vaginal packing, when, in spite of much haemorrhage having occurred, instrumental removal of products of conception is regarded as too hazardous. After dilatation has occurred, these products, if not already spontaneously expelled, may be gently removed by the finger, aided, if necessary, by forceps. In haemorrhage during or after the third month, with incomplete cervical dilatation, the use of a colpeurynter is considered preferable to rapid and forcible dilatation or to vaginal hysterotomy.

PATHOLOGY.

739. The Regeneration of Peripheral Nerves.

A SUMMARY is given by LHERMITE (*Ann. de Méd.*, April 1921) of the recent changes of view that have occurred in connexion with the regeneration of peripheral nerves. From the work of Dustin, it appears probable that the direction which is followed by the budding axis cylinders of the central end of the nerve is determined largely by the active proliferation of the cells of the sheath of Schwann around the peripheral end; from this end there is formed a syncytium of growing cells, into the meshes of which the regenerated axis cylinders find their way. The fundamental tendency existing for the two ends of a divided nerve trunk to unite again is explained by two theories, in favour of each of which experimental evidence is adduced: (1) The degeneration of the severed nerve produces an alteration in the electrical potential existing at the surface of the nerve trunk; from the normal positive it becomes negative, and persists negative during the whole period of degeneration. This difference in potential acts not only as an excitant of cellular regeneration, but determines the direction of growth of the axons; to this current

existing between the cerebral and peripheral ends of the divided nerve is given the term "current of regeneration." (2) Marinresco has shown that in regenerating nerves certain ferments appear, one of an organic nature having its origin in the granules of the protoplasm of the sheath of Schwann, and the other of an inorganic (ferrous) nature which plays the part of a catalyzer of peroxidase. It is probable that these ferments are closely related to the growth of the regenerating nerve. From the surgical point of view the best means of ensuring the union of the two ends of a divided nerve is neither by the use of a piece of vein, nor of living nerve tissue, nor even by direct suture of the two extremities, but by the interposition of a fragment of nerve killed and fixed in alcohol or formol.

740. Hepatitis and Nephritis Secondary to Round Ulcer of the Stomach.

LE NOIR, RICHEL, and JACQUELIN (*Ann. de Méd.*, April, 1921) find that hepatic and renal insufficiency are frequently present in patients suffering from round ulcer of the stomach. In investigating the functions of the kidney, the blood urea, the non-protein nitrogen of the blood, and Ambard's constant were determined, while in the case of the liver, alimentary glycosuria, coagulation time of the blood, digestive haemoclasia, and the presence of urobilinuria were the methods employed. The insufficiency of these organs is correlated not so much with the age of the ulcer as with its extension and the amount of tissue destruction it gives rise to. Once cicatrization of the ulcer occurs, the hepatic and renal insufficiency seems to disappear. On these lines they explain the origin of haematemesis, holding that in some cases this is due largely to the decreased coagulability of the blood. Similarly, certain cases of intractable vomiting are considered to be due to a hepato-nephritis—a theory supported by the fact that the autopsy of fatal cases of this nature revealed the presence of cirrhosis and fatty degeneration of the liver, together with chronic nephritis. Operative shock is particularly severe in many cases, and *post-mortem* observations reveal the presence of marked hepatic lesions following gastro-enterostomy; this shock they attribute to a definite post-operative hepato-nephritis. From a therapeutic point of view they advise caution in the use of opium and of chloroform water in making up prescriptions for the relief of pain, while for the production of anaesthesia for operation they prefer nitrous oxide or local anaesthetics to chloroform. The presence of sugar in the urine should be carefully tested for during the post-operative period, to afford evidence of hepatic insufficiency. Acidosis, which is very liable to appear, should be combated by the administration of carbohydrates and of alkalis in large doses.

741. Pathology of Pregnancy Toxaemias and Nephritis.

FROM an examination of 12 cases of toxæmia of pregnancy, 20 cases of nephritis in pregnancy, and numerous controls, MACKENZIE WALLIS (*Journ. of Obstet. and Gynaecol. of the British Empire*, 1921, i) finds that in the toxæmias of pregnancy the blood content is normal with respect to urea, sugar and other constituents; the absence of alteration in the sugar content is regarded as evidence against the view that pregnancy toxæmias are associated with endocrine gland disturbances. Analysis of the urine shows that the ratio of albumin to globulin is about 6 to 1 in nephritis as compared with about 2 to 1 in the toxic albuminurias of such conditions as eclampsia, a finding which has prognostic importance. In normal pregnant women the diastase content of the urine is remarkably constant and does not differ from that found in the non-pregnant or in males. In true toxic vomiting of pregnancy and in eclampsia, on the other hand, the diastase content of the urine is much increased; it may remain abnormally high after other signs and symptoms of toxæmia have disappeared and may by a sudden increase foreshadow the advent of toxæmic manifestations. In eclampsia, unlike pancreatic disease, there is no marked increase in the diastase in the blood. In nephritis in pregnancy, the diastase content of the blood is increased while that of the urine becomes diminished with the renal permeability, usually very considerably. Estimation of urea in the blood indicates whether there is urea retention, and therefore diminished renal function, and may thus form a basis for prognosis in nephritis in pregnancy; the urea content of the blood does not, however, give any clue as to the imminence of uraemia. In assessing the degree of renal damage which is present and in forming a prognosis, a collective interpretation should be given to the results of all the tests mentioned.

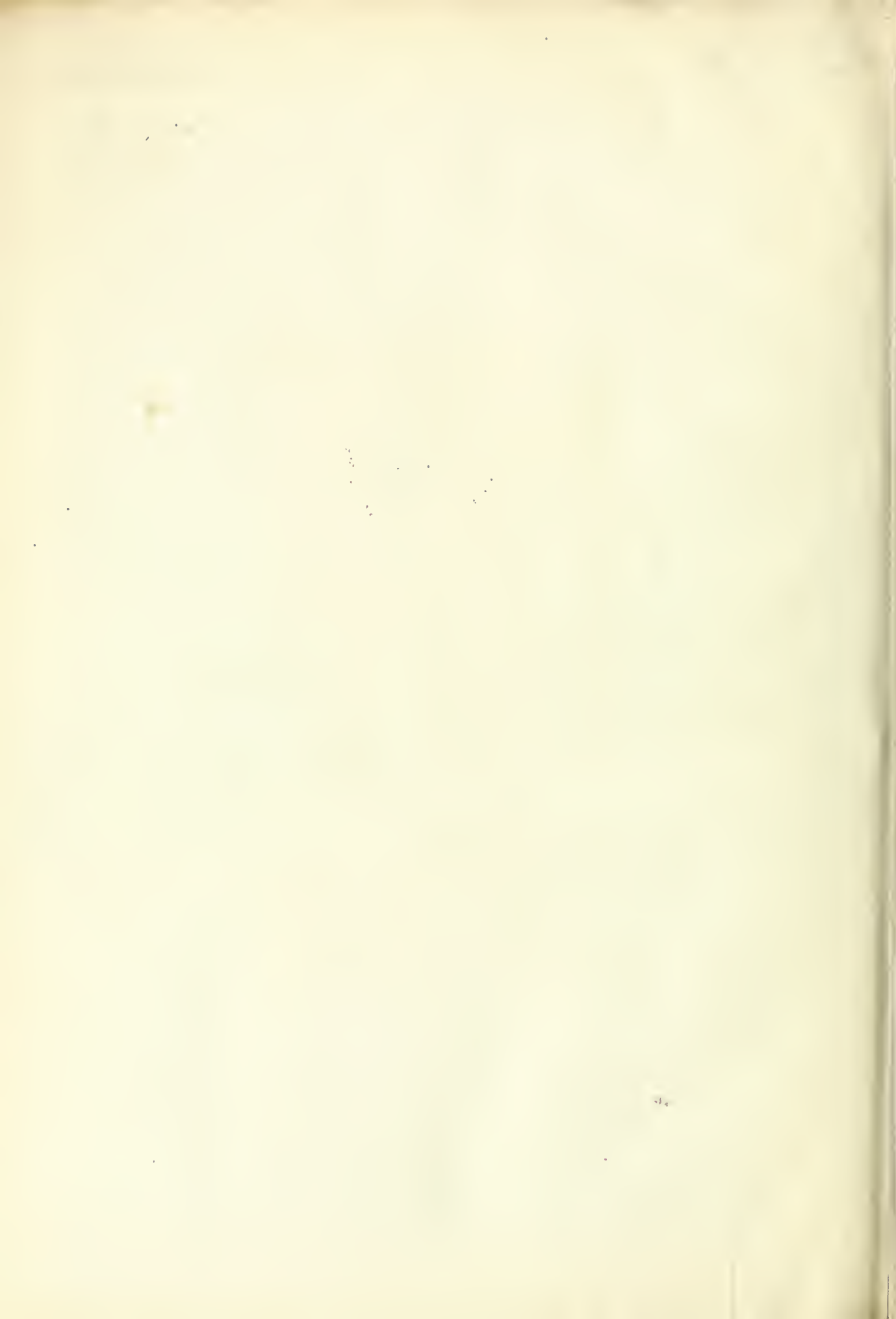

R
31
B93
1921
v.1
cop.2

British medical journal
1921, v.1

**Biological
& Medical
Serials**

PLEASE DO NOT REMOVE
CARDS OR SLIPS FROM THIS POCKET

UNIVERSITY OF TORONTO LIBRARY

STORAGE

